

SECTION 3 HYDRAULIC SYSTEM

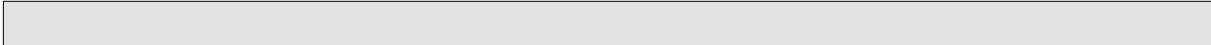

Group 1 Hydraulic Circuit	3-1
Group 2 Main Circuit	3-2
Group 3 Pilot Circuit	3-5
Group 4 Single Operation	3-13
Group 5 Combined Operation	3-28

SECTION 3 HYDRAULIC SYSTEM

GROUP 1 HYDRAULIC CIRCUIT

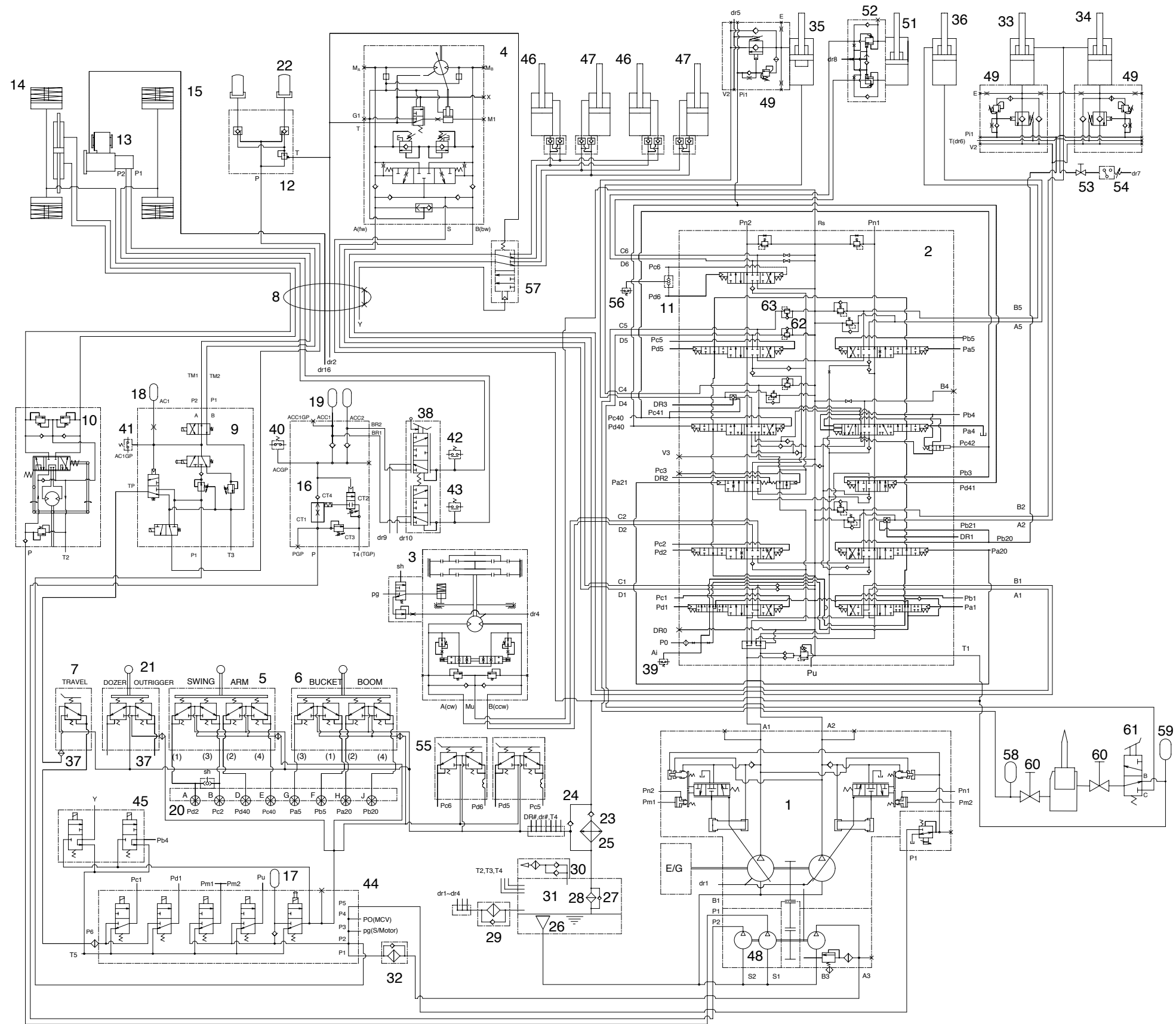

- 1 Main pump
- 2 Main control valve
- 3 Swing motor
- 4 Travel motor
- 5 RCV lever-LH
- 6 RCV lever-RH
- 7 RCV pedal
- 8 Turning joint
- 9 Transmission control valve
- 10 Steering valve
- 11 Shuttle valve
- 12 Locking valve
- 13 Transmission
- 14 Front axle
- 15 Rear axle
- 16 Brake supply valve
- 17 Accumulator
- 18 Accumulator
- 19 Accumulator
- 20 Terminal
- 21 RCV dozer
- 22 Oscillating cylinder
- 23 Check valve
- 24 Check valve
- 25 Oil cooler
- 26 Strainer
- 27 Bypass valve
- 28 Return filter
- 29 Spin filter
- 30 Air breather
- 31 Hydraulic tank
- 32 Line filter
- 33 Boom cylinder-LH
- 34 Boom cylinder-RH
- 35 Arm cylinder
- 36 Bucket cylinder
- 37 Last gaurd filter
- 38 Brake valve
- 39 Pressure switch
- 40 Pressure switch
- 41 Pressure switch
- 42 Pressure switch
- 43 Pressure switch
- 44 5-Cartridge valve
- 45 2-Cartridge valve
- 46 Outrigger cylinder-LH
- 47 Outrigger cylinder-RH
- 48 Gear pump
- 49 Safety lock valve
- 51 2 Pcs boom cylinder
- 52 Safety lock valve
- 53 Shut off valve
- 54 Pressure switch
- 55 Option pedal
- 56 Pressure switch
- 57 Selector valve
- 58 Accumulator
- 59 Accumulator
- 60 Stop valve
- 61 Selector valve
- 62 Port relief valve
- 63 Port relief valve

14W73HC01A

GROUP 2 MAIN CIRCUIT

The main hydraulic circuit consists of suction circuit, delivery circuit, return circuit and drain circuit.

The hydraulic system consists of one main pump, one control valve, one swing motor, four cylinders and two travel motors.

The swash plate type variable displacement axial piston pump is used as the main pump and it is driven by the engine at ratio 1.0 of engine speed.

1. SUCTION AND DELIVERY CIRCUIT

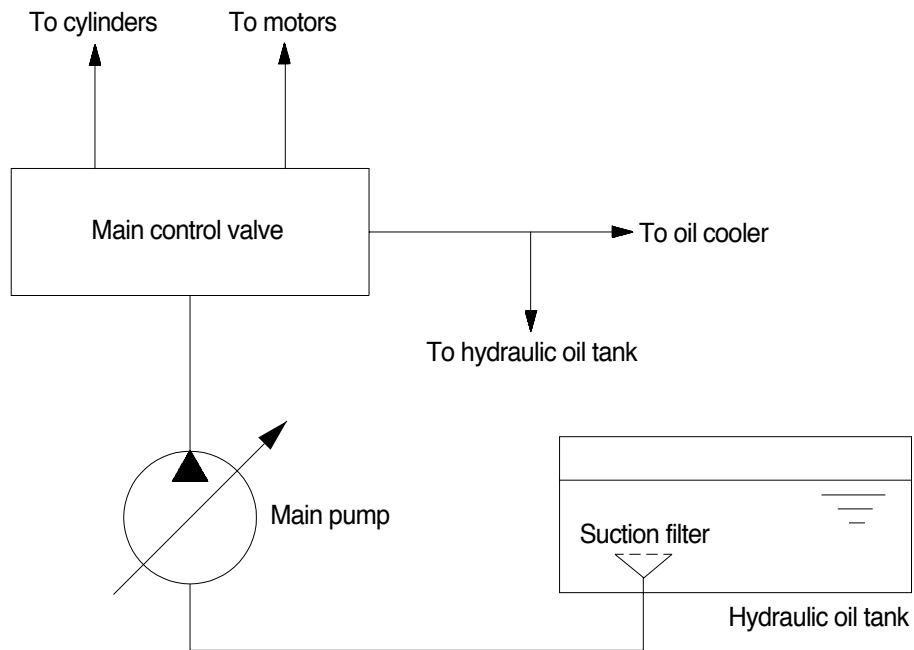

3-2 (290LC-7)

The pumps receive oil from the hydraulic tank through a suction filter. The discharged oil from the pump flows into the control valve and goes out the tank ports.

The oil discharged from the main pump flows to the actuators through the control valve.

The control valve controls the hydraulic functions.

The return oil from the actuators flows to the hydraulic tank through the control valve and the oil cooler.

2. RETURN CIRCUIT

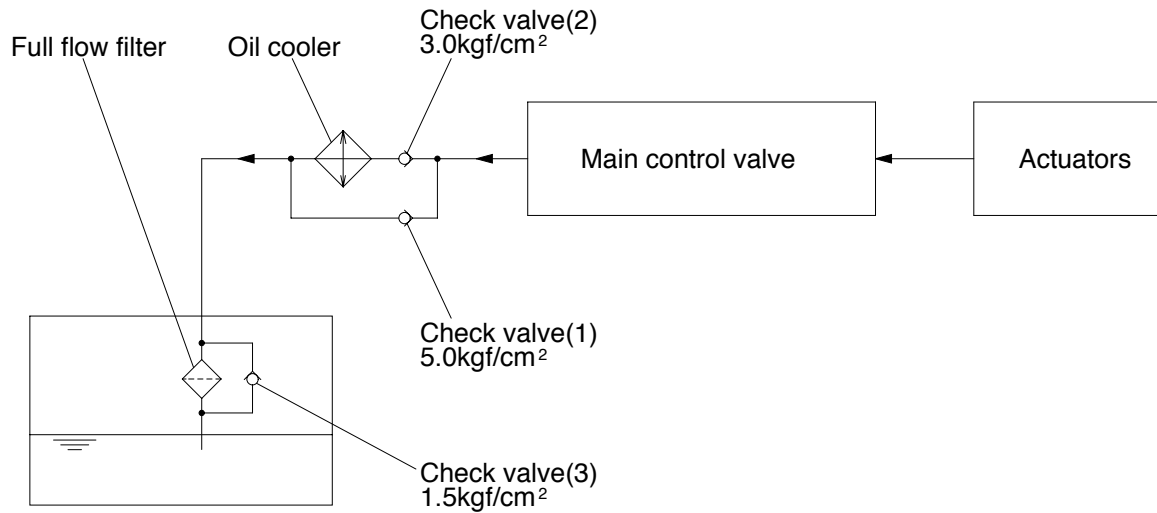

20W73CI01

All oil from each actuator returns to the hydraulic tank through the control valve.

The bypass check valves are provided in the return circuit.

The setting pressure of bypass check valves are 3.0kgf/cm²(43psi) and 5.0kgf/cm²(71psi). Usually, oil returns to the hydraulic tank from the left side of control valve through oil cooler.

When oil temperature is low, viscosity becomes higher and flow resistance increases when passing through the oil cooler. When the oil pressure exceeds 5.0kgf/cm²(71psi), the oil returns directly to the hydraulic tank, resulting in the oil temperature being raised quickly at an appropriate level.

When the oil cooler is clogged, the oil returns directly to the hydraulic tank through bypass check valve(1).

The return filter and bypass relief valve are provided in the hydraulic tank.

The oil returned from right and left side of control valve is combined and filtered by the return filter. A bypass relief valve is provided in the full-flow filter.

When the filter element is clogged, the bypass relief valve opens at 1.5kgf/cm²(21psi) differential pressure.

3. DRAIN CIRCUIT

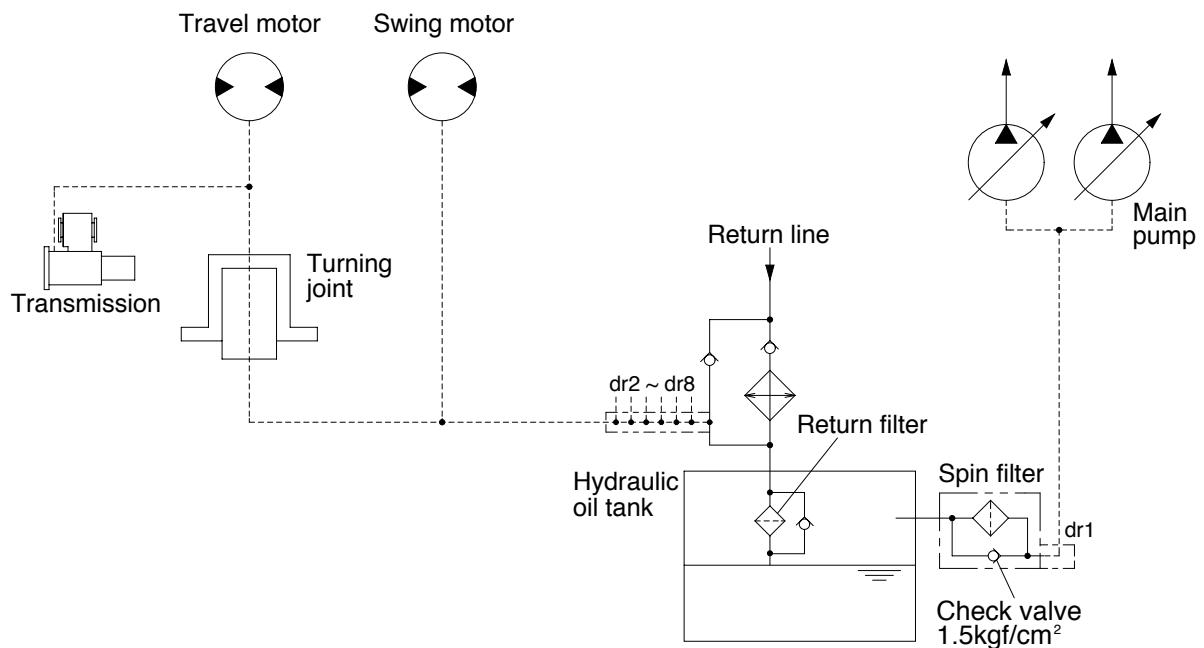

20W73CI02

Besides internal leaks from the motor, transmission, front and rear axle the oil for lubrication circulates. The main pump drain oil have to be fed to the hydraulic tank passing through spin filter. When the drain oil pressure exceed 1.5kgf/cm^2 (21psi), the oil returns to the hydraulic tank directly.

1) TRAVEL MOTOR DRAIN CIRCUIT

Oil leaking from the travel motor comes out of the drain ports provided in the respective motor casing and joins with each other. This oil passes through joint and returns to the hydraulic tank after being filtered by return filter.

2) SWING MOTOR DRAIN CIRCUIT

Oil leaking from the swing motor come out and return to the hydraulic tank passing through a return filter.

3) MAIN PUMP DRAIN CIRCUIT

Oil leaking from main pump come out and return to the hydraulic tank passing through spin filter.

4) TRANSMISSION DRAIN CIRCUIT

Oil leaking from transmission comes out and returns to the hydraulic tank passing through return filter.

GROUP 3 PILOT CIRCUIT

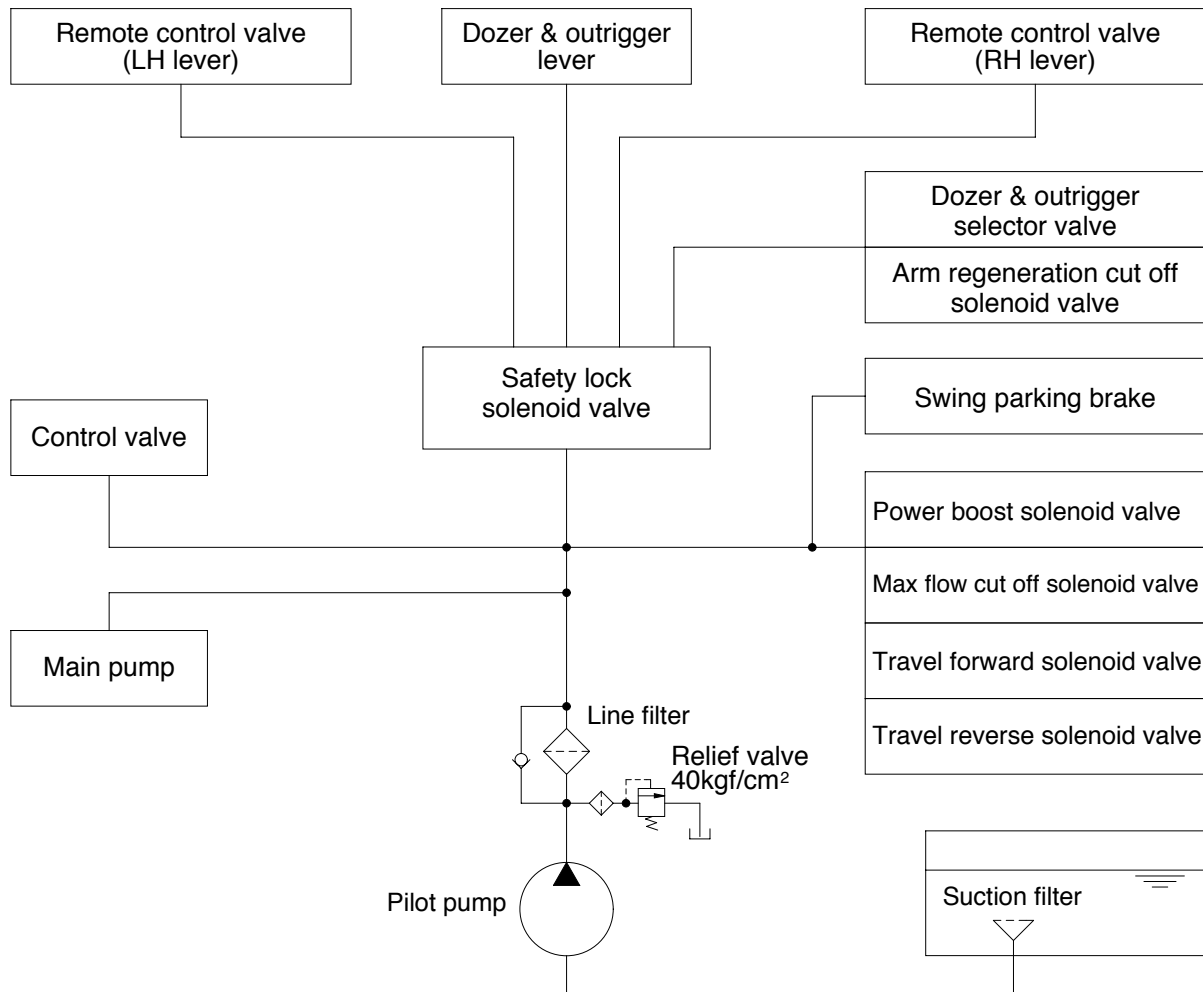

14W73CI03

The pilot circuit consists of suction circuit, delivery circuit and return circuit.

The pilot pump is provided with relief valve, receives the oil from the hydraulic tank through the suction filter.

The discharged oil from the pilot pump flows to the remote control valve, EPPR valve, solenoid valve assemblies, swing parking brake, main control valve and safety lock solenoid valve through line filter.

1. SUCTION, DELIVERY AND RETURN CIRCUIT

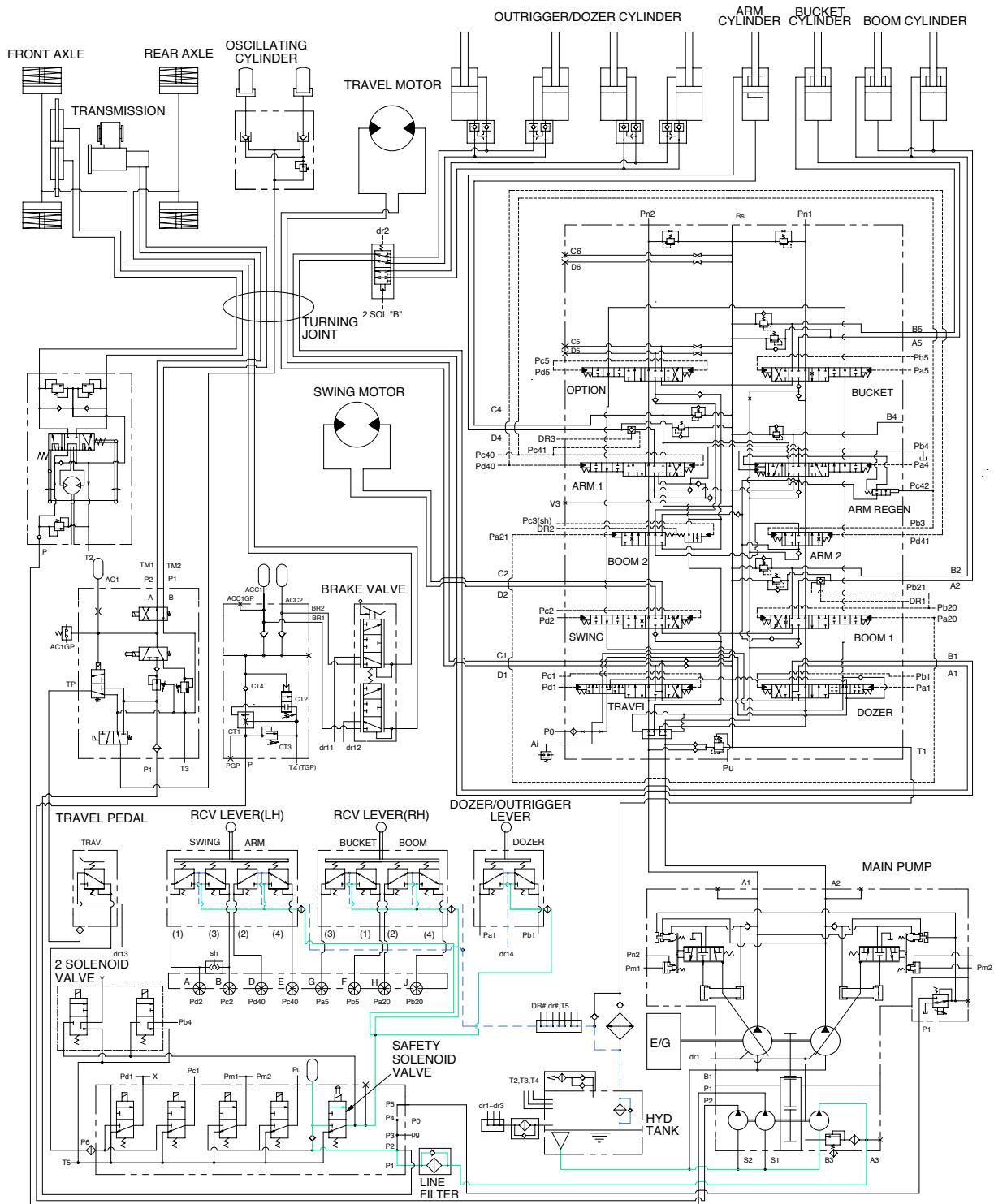

14W73HC02

The pilot pump receives oil from the hydraulic tank. The discharged oil from the pilot pump flows to the safety solenoid valve through the line filter. The oil is filtered by the line filter. The pilot relief valve is provided in the pilot pump for limiting the pilot circuit pressure.

The oil filtered by line filter flows remote control valve through safety solenoid valve.

The return oil from remote control valve is returned to the hydraulic tank.

2. SAFETY SOLENOID VALVE(SAFETY LEVER)

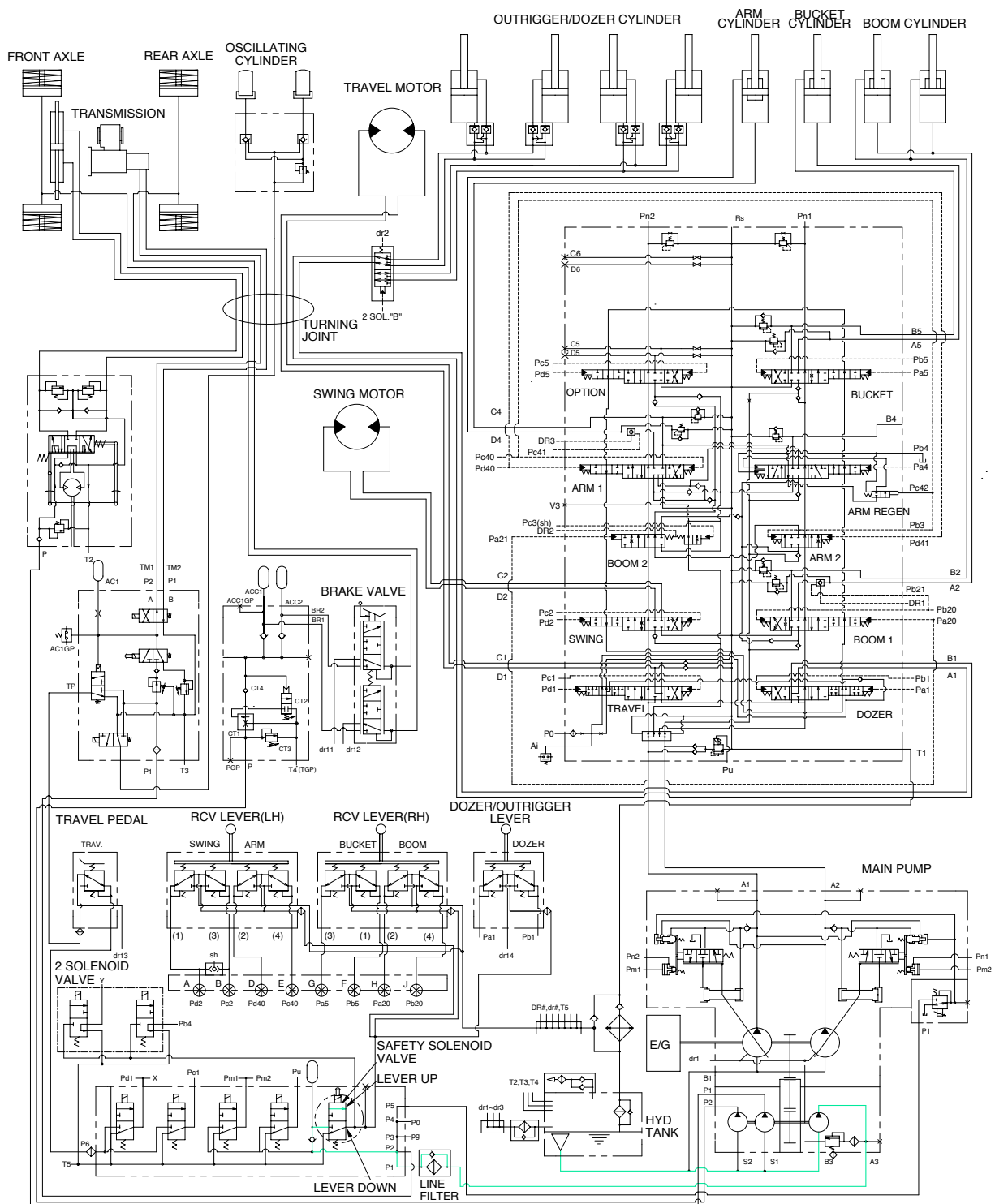

14W73HC03

When the lever of the safety solenoid valve is moved upward, oil flows into the remote control valve through solenoid valve and line filter.

When the lever of the safety solenoid valve moved downward, oil does not flows into the remote control valve, because of blocked port.

3. MAIN RELIEF PRESSURE CHANGE SYSTEM

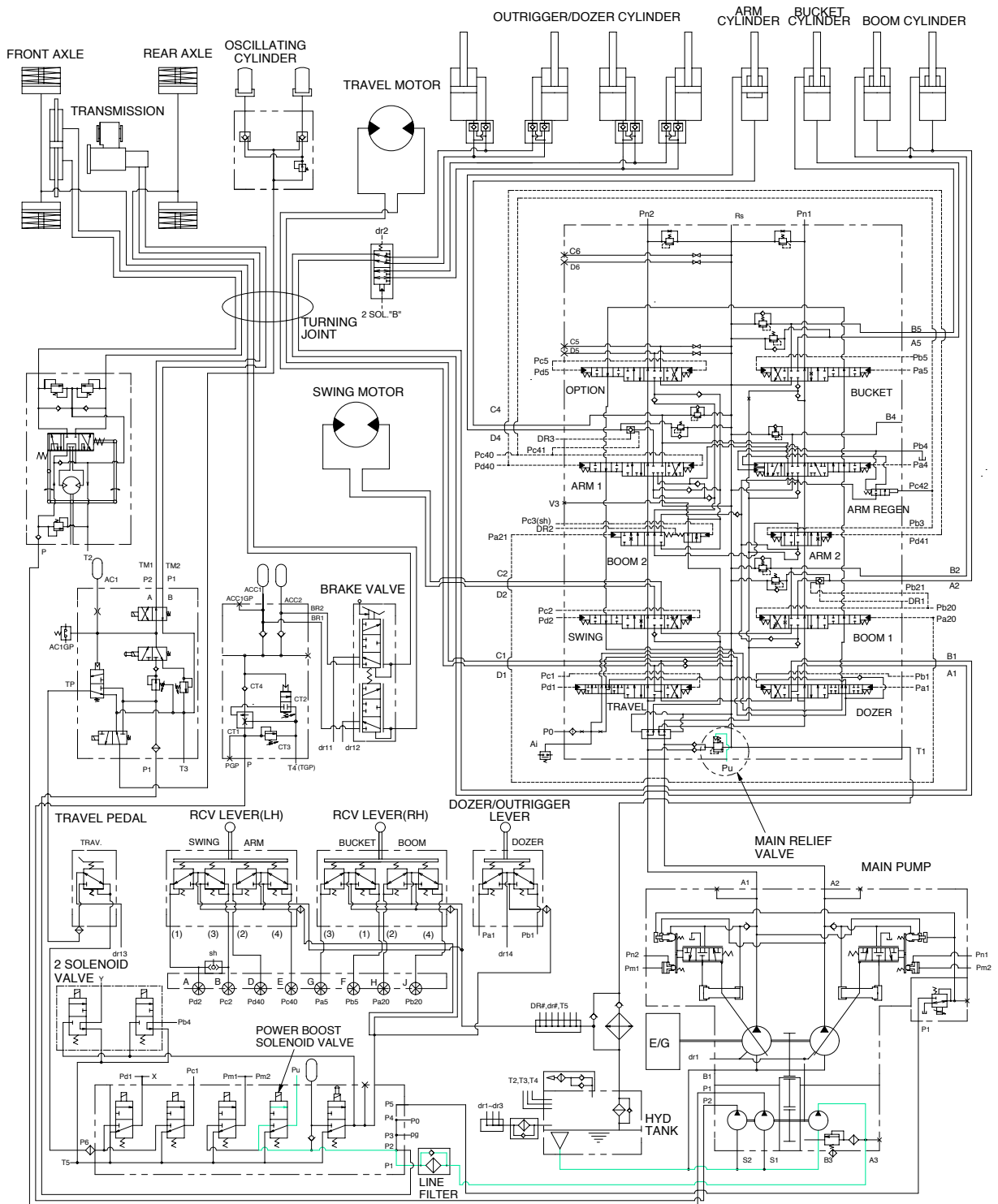

14W73HC04

When the power boost switch on the left control lever is pushed ON, the power max solenoid valve is actuated, the discharged oil from the pilot pump into Pu port of the main relief valve in main control valve ; Then the setting pressure of the main relief valve is raises from 330kgf/cm² to 360kgf/cm² for increasing the digging power. And even when press continuously, it is canceled after 8 seconds.

4. SWING PARKING BRAKE RELEASE

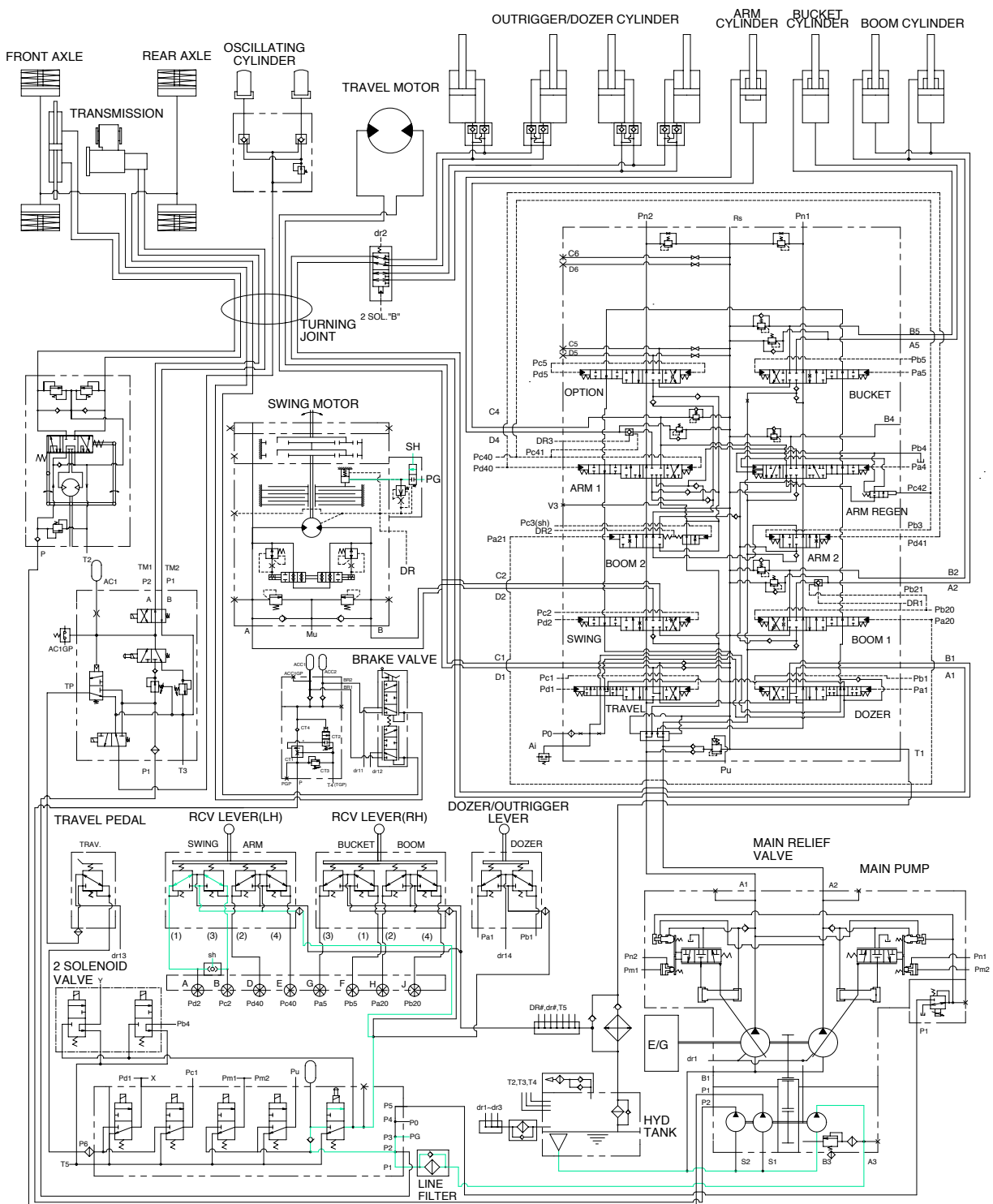

14W73HC05

When the swing control lever is operated, the pilot oil flow into SH port of shuttle valve, this pressure move spool so, discharged oil from pilot pump flow into PG port.

This pressure is applied to swing motor disc, thus the brake released.

When the swing control lever is set neutral position, oil in the swing motor disc cylinder is drain, thus the brake is applied.

5. TRAVEL SPEED SELECTION SYSTEM

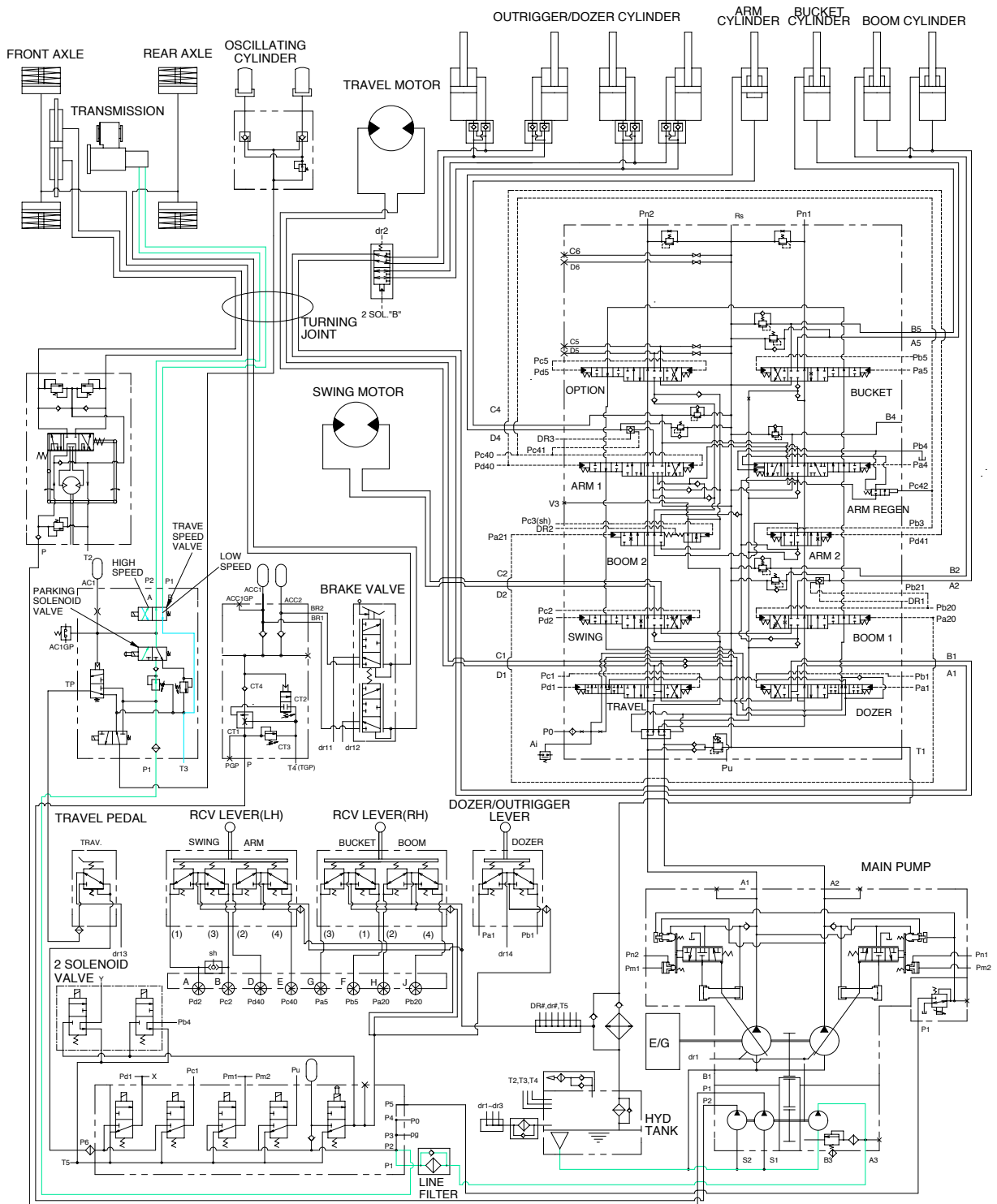

14W73HC06

When RH multifunction switch was placed in high or low position, the pressure oil from pilot pump flows through parking solenoid valve of transmission control valve to travel speed solenoid valve, thus the transmission is changed into high or low speed condition.

6. MAX FLOW CUT OFF SYSTEM

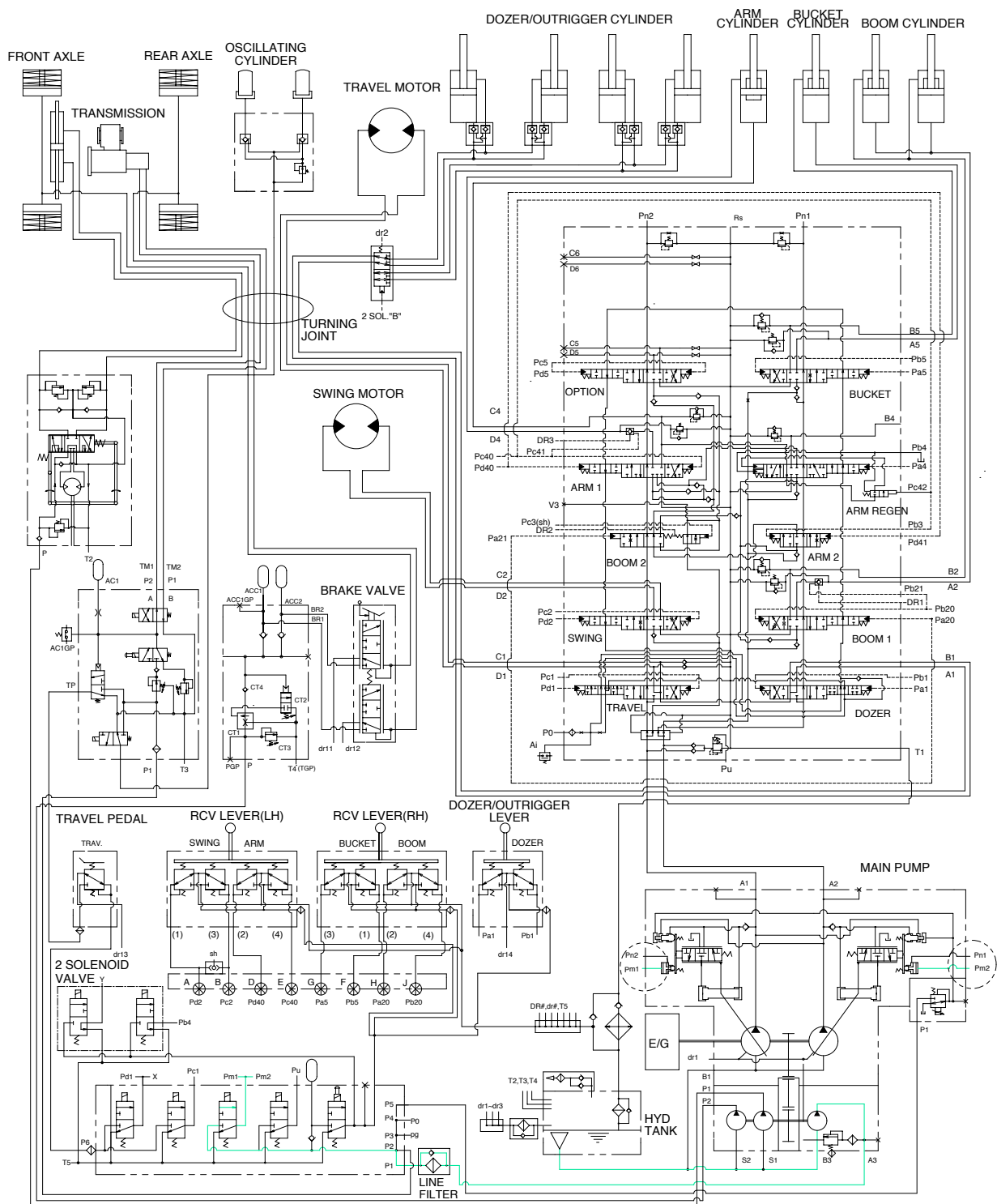

14W73HC07

When the breaker operation mode is selected on the cluster, max flow cut off solenoid valve actuates automatically.

Thus pilot pressure (Pm1,2) is sent to the regulator and pump discharge volume is decreased.

7. ARM REGENERATION CUT OFF SYSTEM

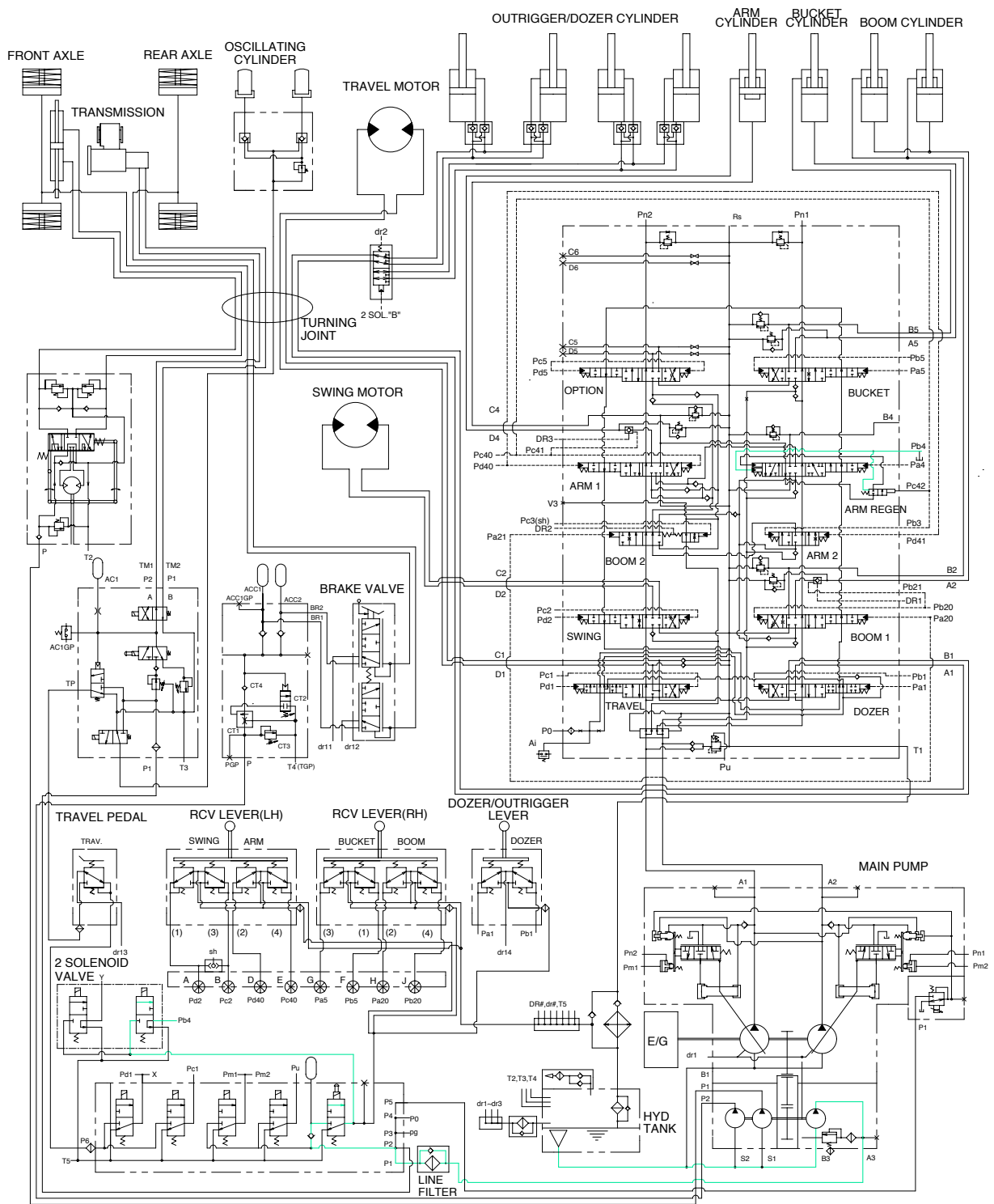

14W73HC08

When the heavy duty mode switch on the cluster is pushed ON, the arm regeneration solenoid valve is deactivated and the arm regeneration spool is returned to neutral position.

The arm regeneration function is activated.

Then, arm operation speed is increased.

GROUP 4 SINGLE OPERATION

1. BOOM UP OPERATION

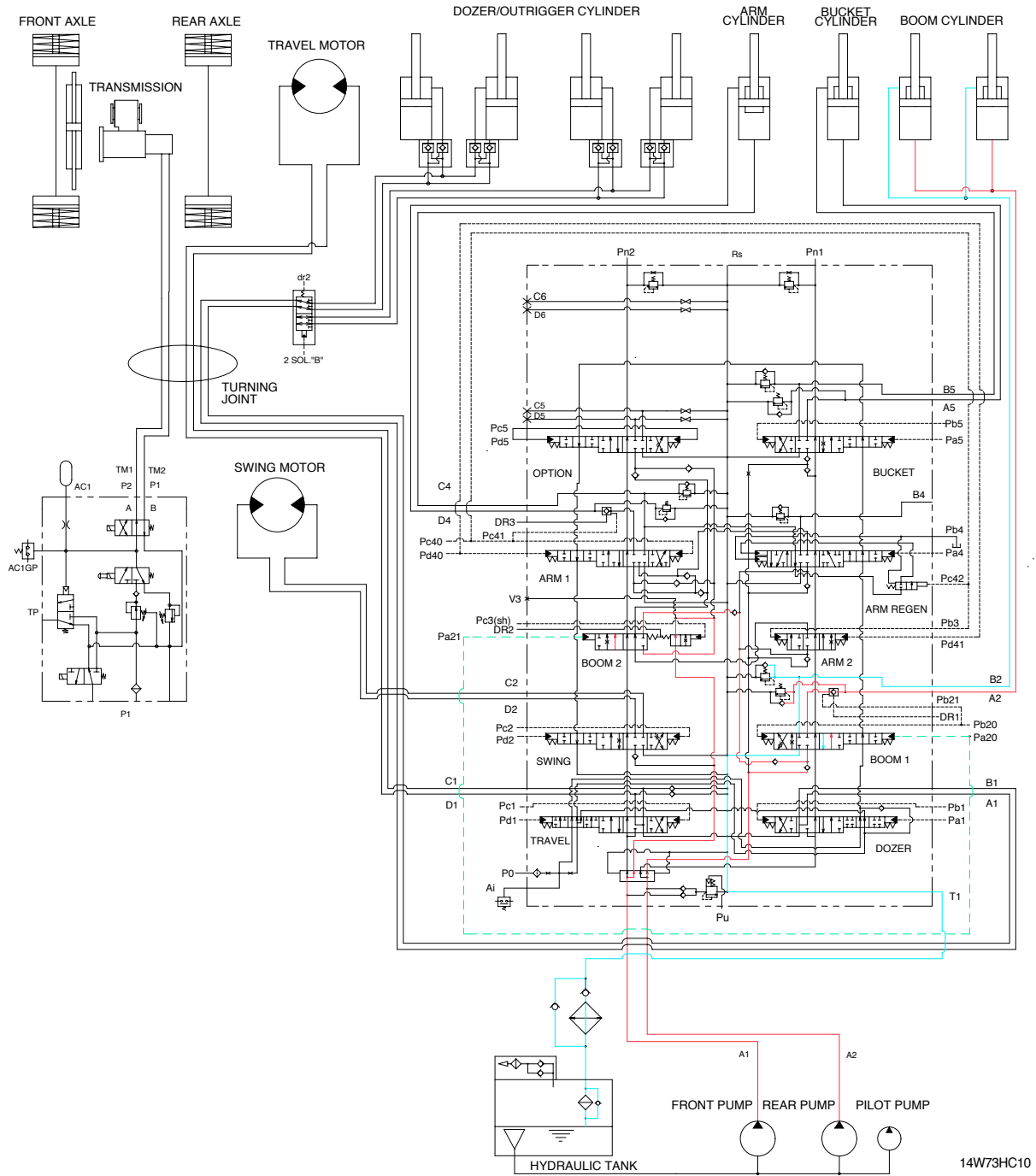

When the right control lever is pulled back, the boom spools in the main control valve are moved to the up position by the pilot oil pressure from the remote control valve.

The oil from the front and rear pump flows into the main control valve and then goes to the large chamber of boom cylinders. At the same time, the oil from the small chamber of boom cylinders returns to the hydraulic oil tank through the boom spool in the main control valve. When this happens, the boom goes up. The excessive pressure in the boom cylinder bottom end circuit is prevented by relief valve. When the boom is up and the control lever is returned to neutral position, the circuit for the holding pressure at the bottom end of the boom cylinder is closed by the boom holding valve. This prevents the hydraulic drift of boom cylinder.

2. BOOM DOWN OPERATION

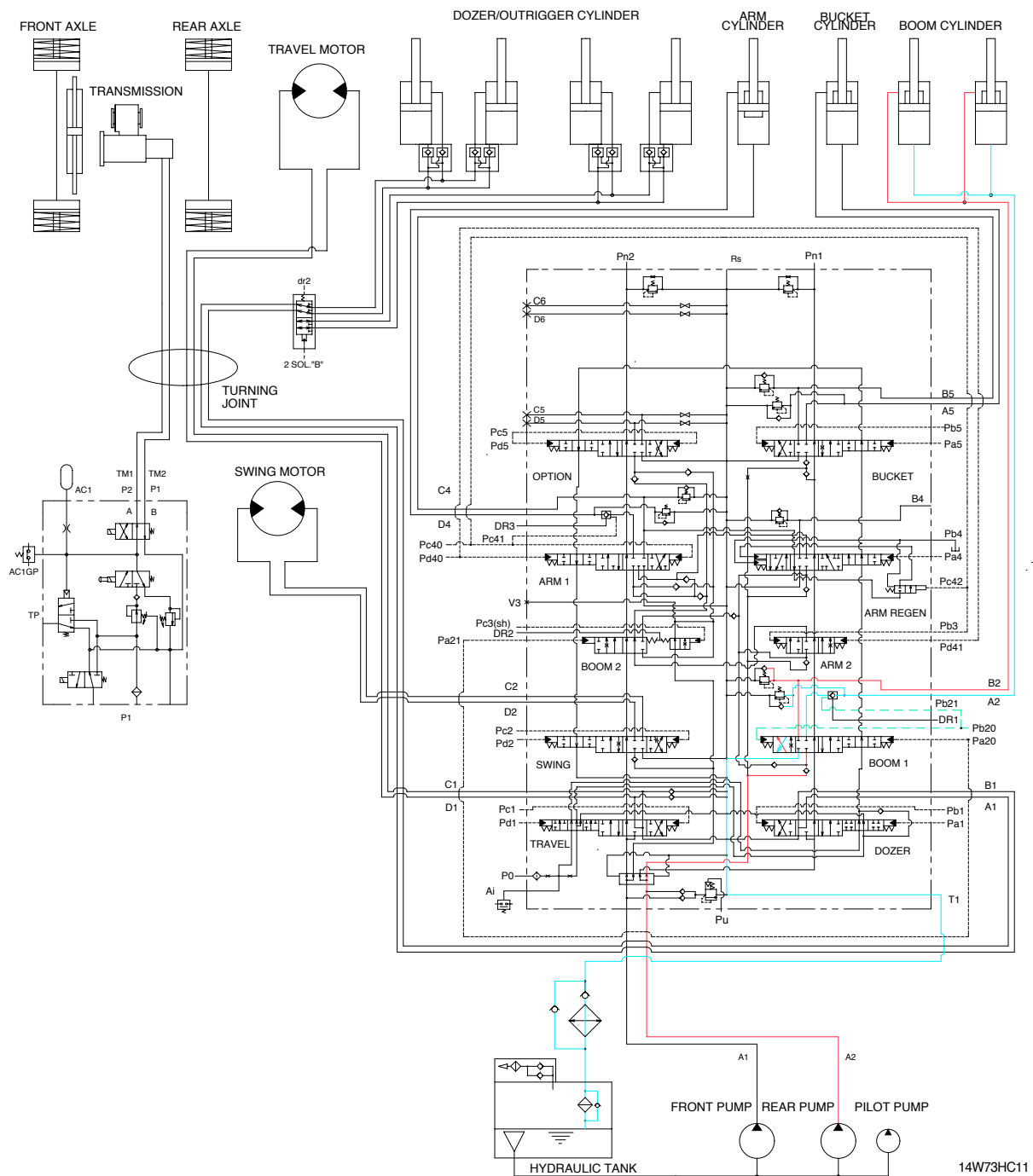

When the right control lever is pushed forward, the boom spools in the main control valve are moved to the down position by the pilot oil pressure from the remote control valve.

The oil from the rear pump flows into the main control valve and then goes to the small chamber of boom cylinders. At the same time, the oil from the large chamber of boom cylinders returns to the hydraulic tank through the boom spool in the main control valve.

When the down speed of boom is faster, the oil returned from the large chamber of boom cylinder combines with the oil from the rear pump, and flows into the small chamber of the cylinder.

This prevents cylinder cavitation by the negative pressure when the rear pump flow can not match the boom down speed. And the excessive pressure in the boom cylinder rod end circuit is prevented by the relief valve.

3. ARM ROLL IN OPERATION

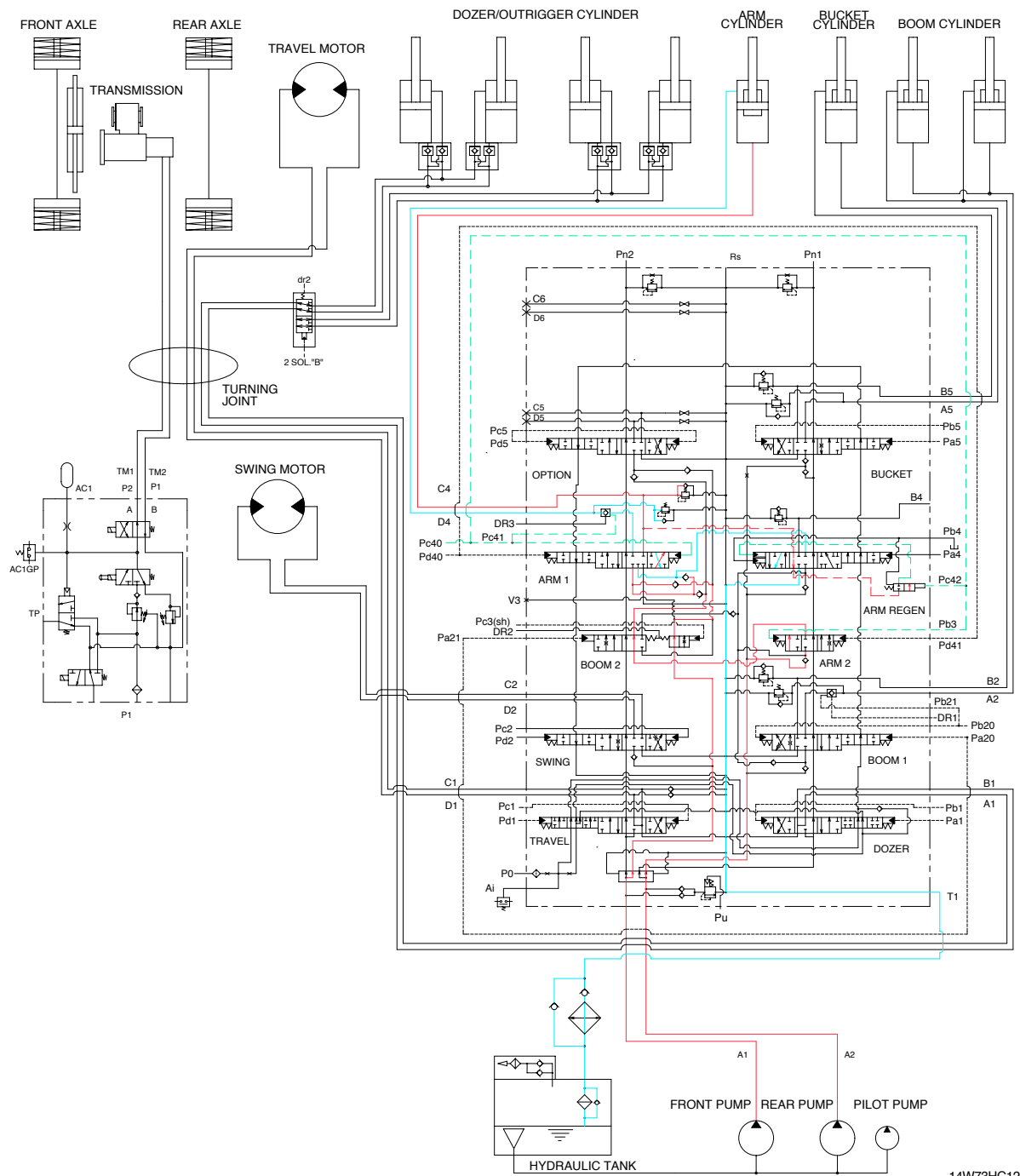

14W73HC12

When the left control lever is pulled back, the arm spools in the main control valve are moved to the roll in position by the pilot oil pressure from the remote control valve.

The oil from the front and rear pump flows into the main control valve and then goes to the large chamber of arm cylinder.

At the same time, the oil from small chamber of arm cylinder returns to the hydraulic oil tank through the arm spool in the main control valve. When this happens, the arm rolls in.

The cavitation which will happen to the bottom of the arm cylinder is also prevented by the make-up valve in the main control valve.

4. ARM ROLL OUT OPERATION

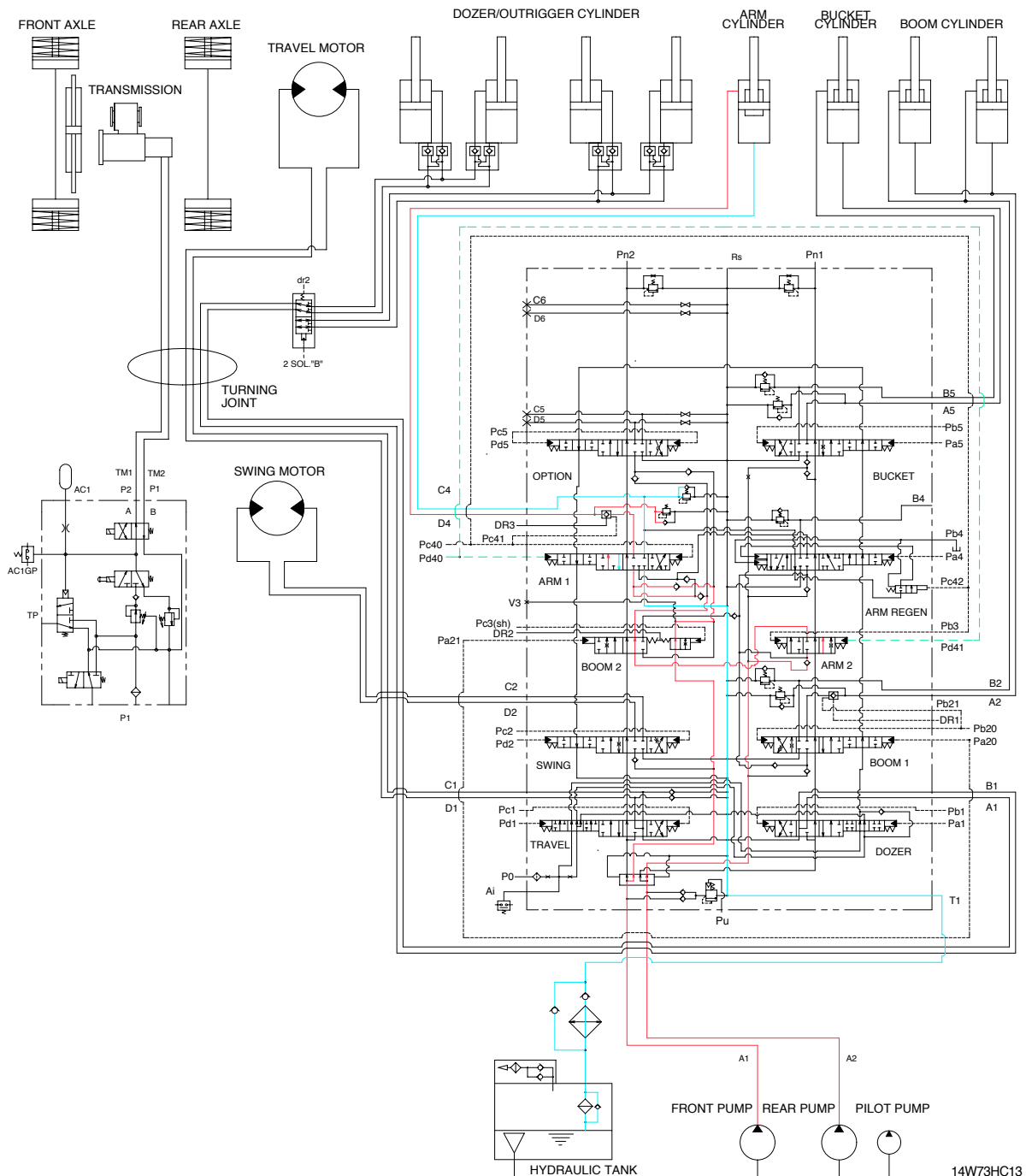

When the left control lever is pushed forward, the arm spool in the main control valve are moved to the roll out position by the pilot oil pressure from the remote control valve.

The oil from the front and rear pump flows into the main control valve and then goes to the small chamber of arm cylinder. At the same time, the oil from the large chamber of arm cylinder returns to the hydraulic oil tank through the arm spool in the main control valve. When this happens, the arm rolls out. The cavitation which will happen to the rod of the arm cylinder is also prevented by the make-up valve in the main control valve. When the arm is roll out and the control lever is returned to neutral position, the circuit for the holding pressure at the rod end of the arm cylinder is closed by the arm holding valve. This prevent the hydraulic drift of arm cylinder.

5. BUCKET ROLL IN OPERATION

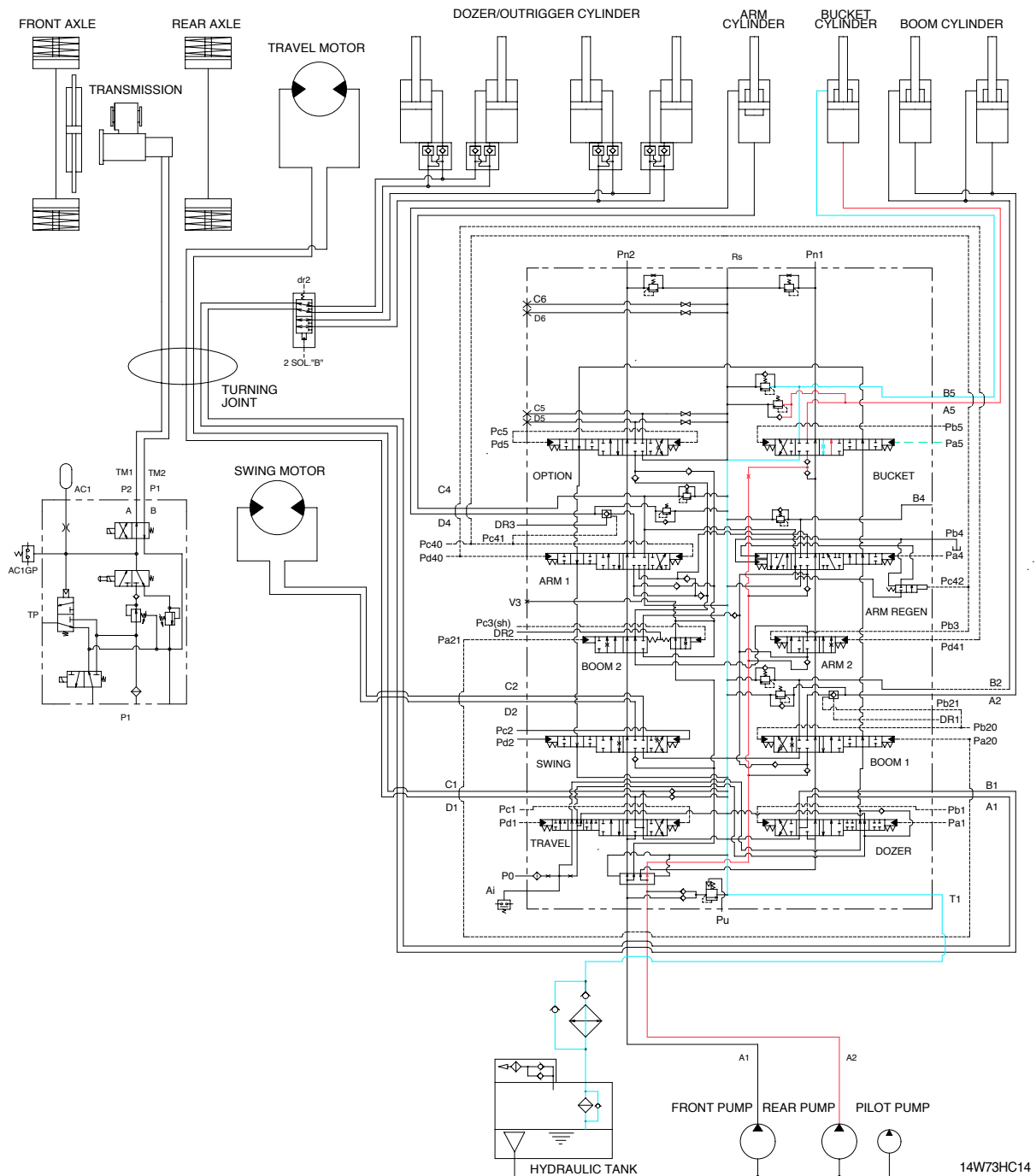

When the right control lever is pulled left, the bucket spool in the main control valve is moved to the roll in position by the pilot oil pressure from the remote control valve.

The oil from the rear pump flows into the main control valve and then goes to the large chamber of bucket cylinder.

At the same time, the oil from the small chamber of bucket cylinder returns to the hydraulic oil tank through the boom spool in the main control valve. When this happens, the bucket rolls in.

The cavitation which will happen to the bottom of the bucket cylinder is also prevented by the make-up valve in the rear of the main control valve.

6. BUCKET ROLL OUT OPERATION

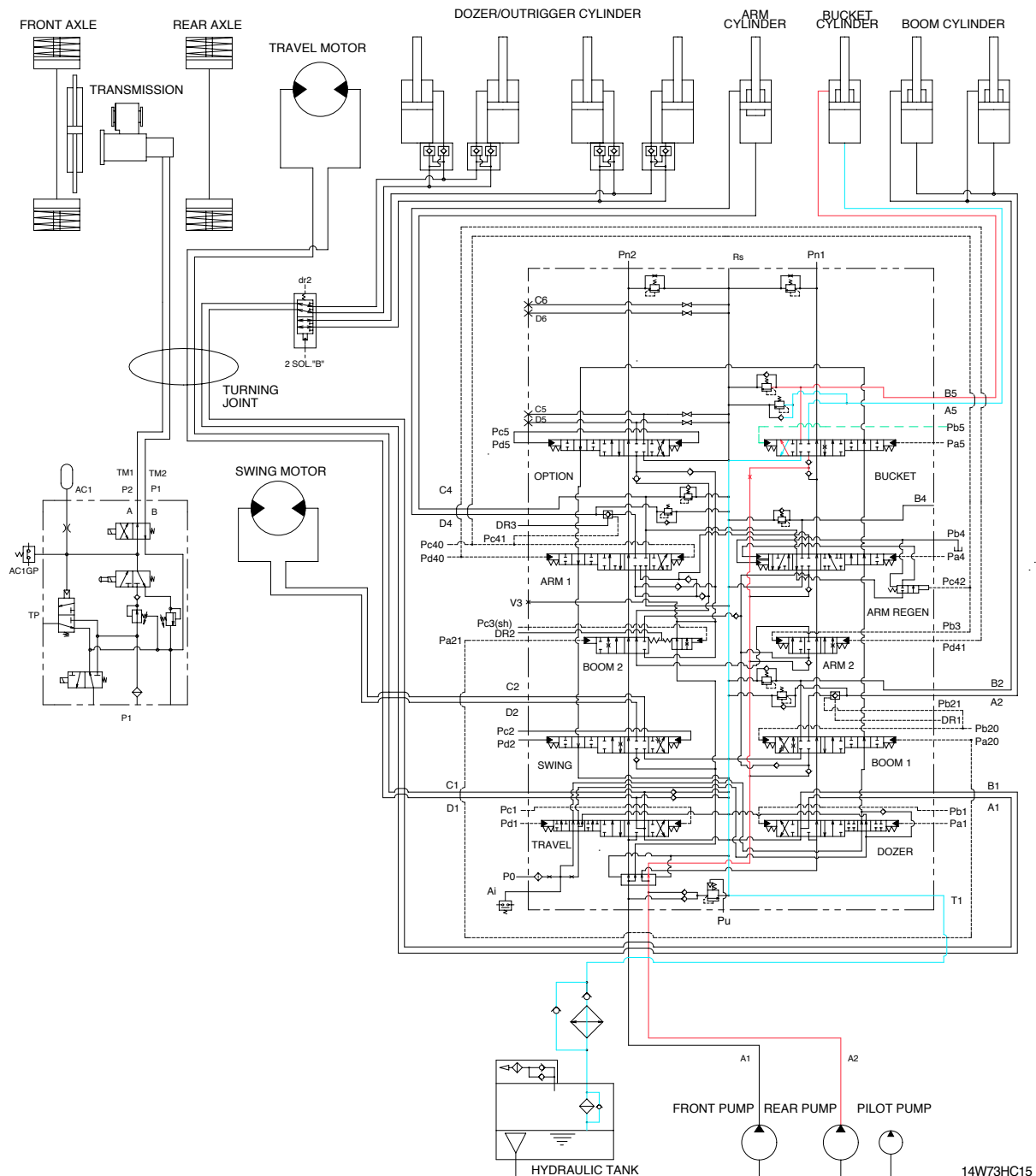

When the right control lever is pushed right, the bucket spool in the main control valve is moved to the roll out position by the pilot oil pressure from the remote control valve.

The oil from the rear pump flows into the main control valve and then goes to the small chamber of bucket cylinder.

At the same time, the oil from the large chamber of bucket cylinder returns to the hydraulic oil tank through the bucket spool in the main control valve. When this happens, the bucket rolls out.

The cavitation which will happen to the rod of the bucket cylinder is also prevented by the make-up valve in the main control valve.

7. DOZER/OUTRIGGER UP OPERATION

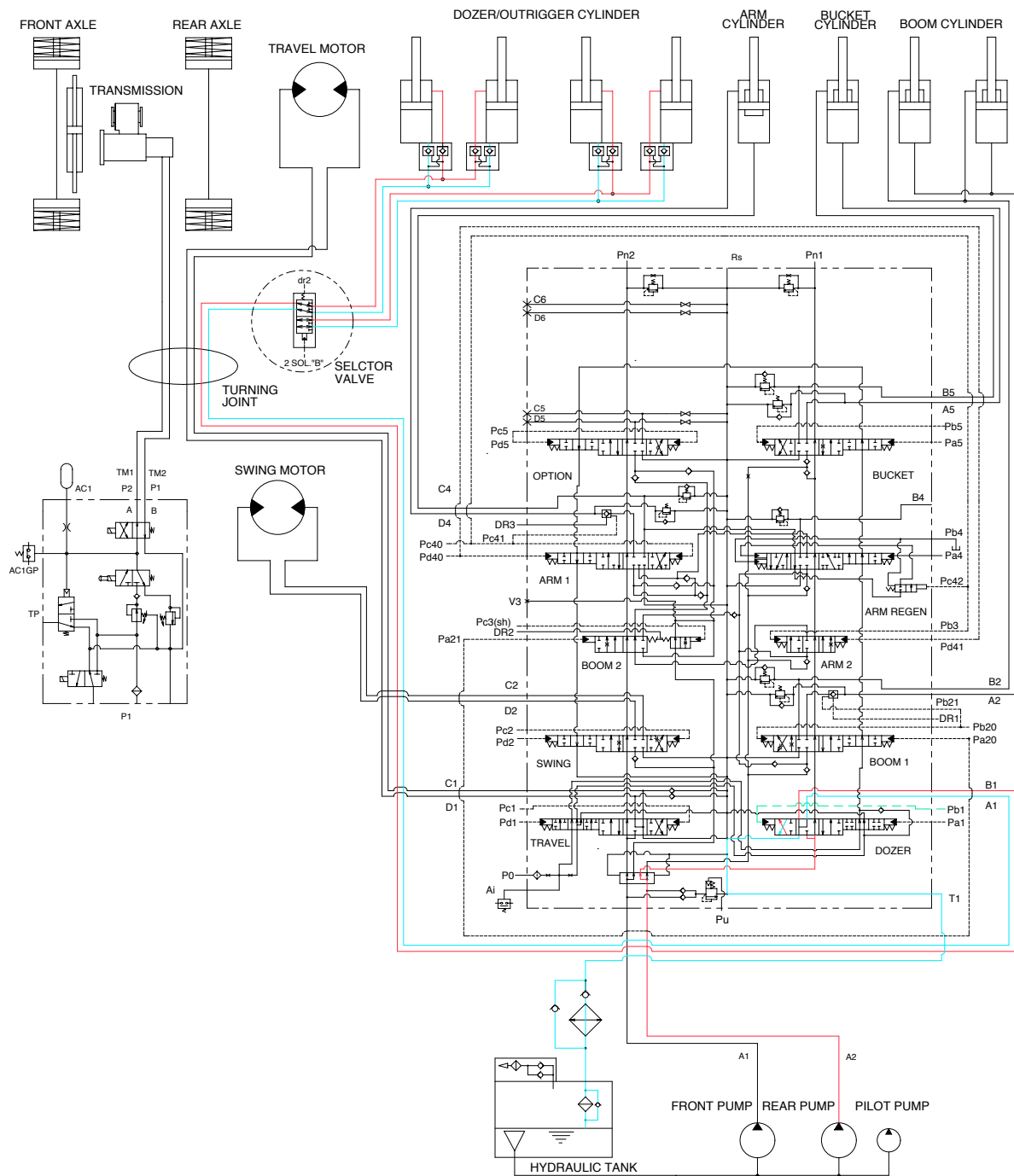

14W73HC19

When the dozer control lever is pulled back, the dozer spool in the main control valve is moved to the dozer up position by the pilot oil pressure from the remote control valve.

The oil from the rear pump flows into the main control valve and then goes to the selector valve.

Then, the selector switch on the switch panel is selected to rear actuator position, the oil from the main control valve flows into the small chamber of rear actuator cylinder (dozer or outrigger).

The other case, the oil flows into the small chamber of front actuator cylinder (dozer or outrigger).

At the same time, the oil from the large chamber of dozer (outrigger) cylinders returns to the hydraulic oil tank through the dozer spool in the main control valve. When this happens, the dozer (outrigger) goes up.

8. DOZER/OUTRIGGER DOWN OPERATION

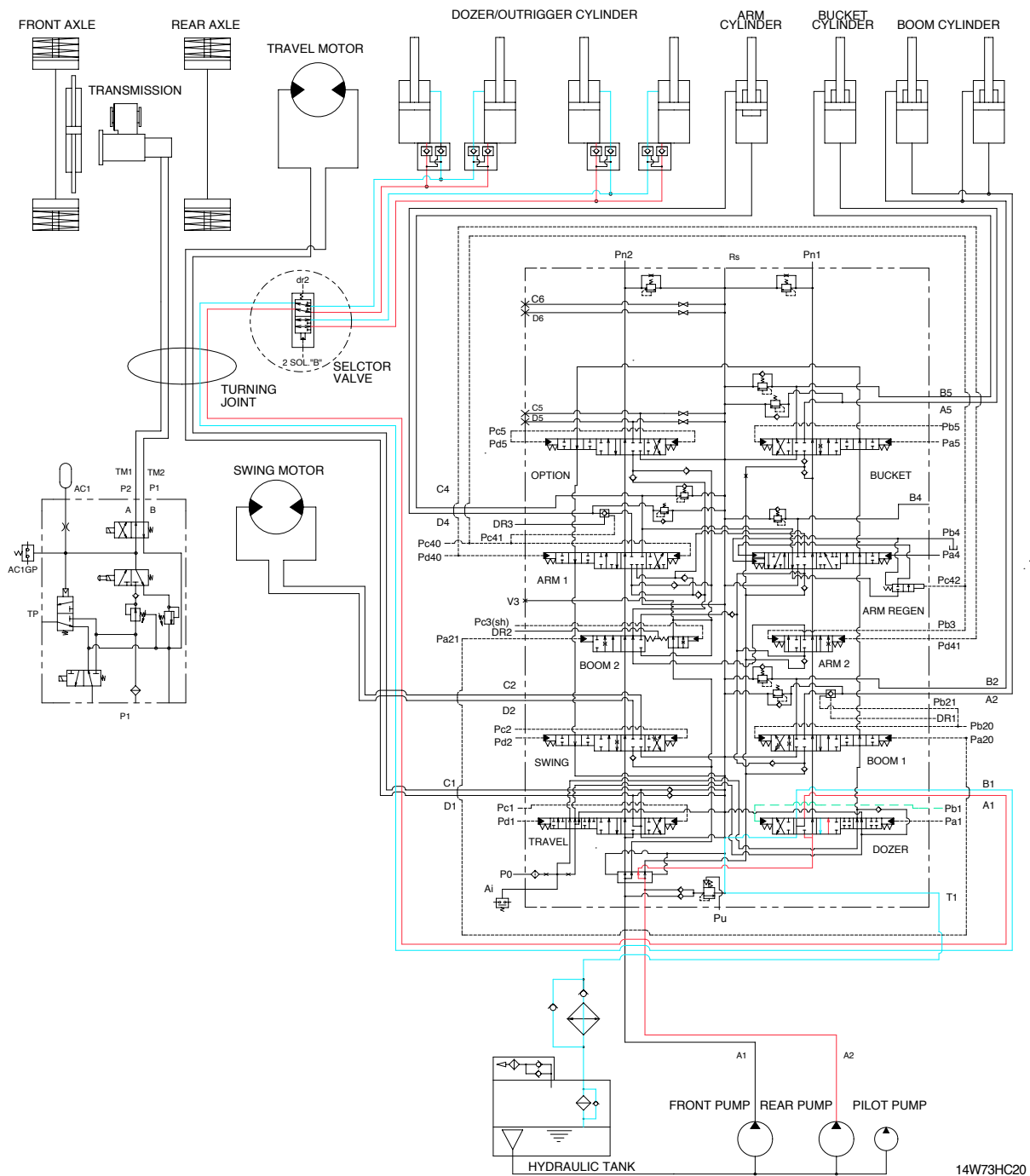

When the dozer control lever is pushed forward, the dozer spool in the main control valve is moved to the dozer down position by the pilot oil pressure from the remote control valve. The oil from the rear pump flows into the main control valve and then goes to the selector valve. Then, the selector switch on the switch panel is selected to rear actuator position, the oil from the main control valve flows into the large chamber of rear actuator cylinder (dozer or outrigger). The other case, the oil flows into the large chamber of front actuator cylinder (dozer or outrigger). At the same time, the oil from the small chamber of dozer (outrigger) cylinders returns to the hydraulic oil tank through the dozer spool in the main control valve. When this happens, the dozer (outrigger) goes up.

9. SWING OPERATION

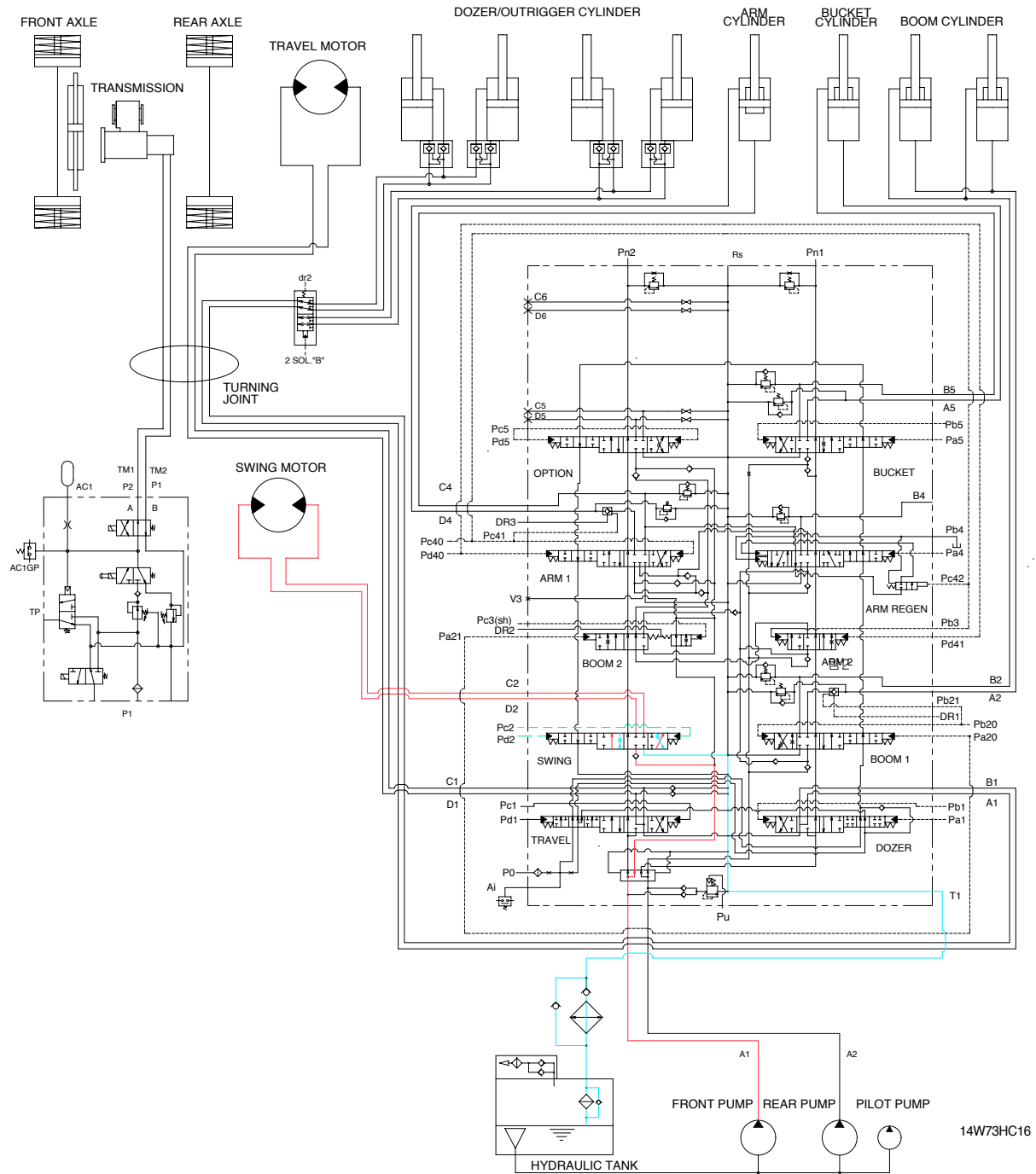

When the left control lever is pushed left or right, the swing spool in the main control valve is moved to the left or right swing position by the pilot oil pressure from the remote control valve.

The oil from the front pump flows into the main control valve and then goes to the swing motor.

At the same time, the return oil from the swing motor returns to the hydraulic oil tank through the swing spool in the main control valve.

When this happens, the superstructure swings to the left or right.

The swing parking brake, make up valve and the overload relief valve are provided in the swing motor. The cavitation which will happen to the swing motor is also prevented by the make up valve in the swing motor itself.

SWING CIRCUIT OPERATION

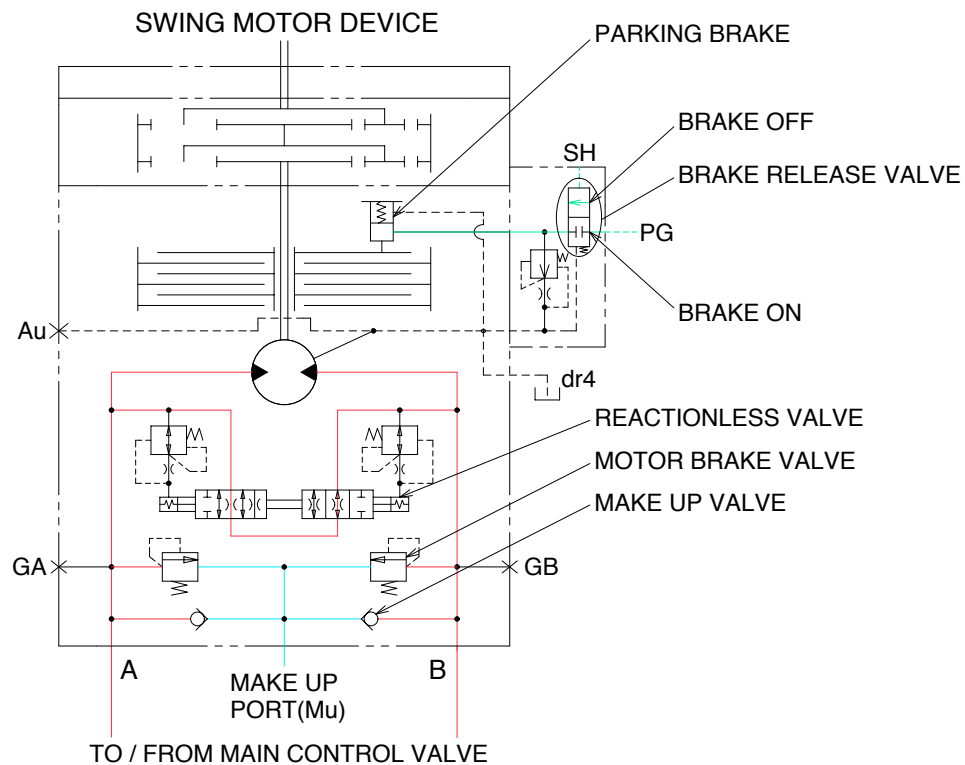

210N73HC15A

1) MOTOR BRAKE VALVE

Motor brake valve for the swing motor limits to cushion the starting and stopping pressure of swing operation.

2) MAKE UP VALVE

The make up valves prevent cavitation by supplying return oil to the vacuum side of the motor.

3) PARKING BRAKE

In case that the parking, of the machine at slope is required during operation, there is the danger of involuntary swing caused by the self weight of the machine. The brake is connected to prevent this involuntary swing.

PARKING BRAKE "OFF" OPERATION

The parking brake is released by the pilot pressure oil from the pilot pump.

When the left control lever placed in the swing position, the pilot pressure at the shuttle valve is transferred to the brake release valve and the brake release valve is change over. Then the pilot pressure lift the brake piston and release the parking brake.

PARKING BRAKE "ON" OPERATION

When the control lever placed in the neutral position, the pressure of the pilot oil passage down.

Then the brake release valve returned to the neutral position and the oil is returned from the brake piston to the tank. And the brake is set to 'ON'.

4) REACTIONLESS VALVE

This reactionless valve absorbs shocks produced as swing motion stops and reduces oscillation cause by swing motion.

10. TRAVEL FORWARD AND REVERSE OPERATION

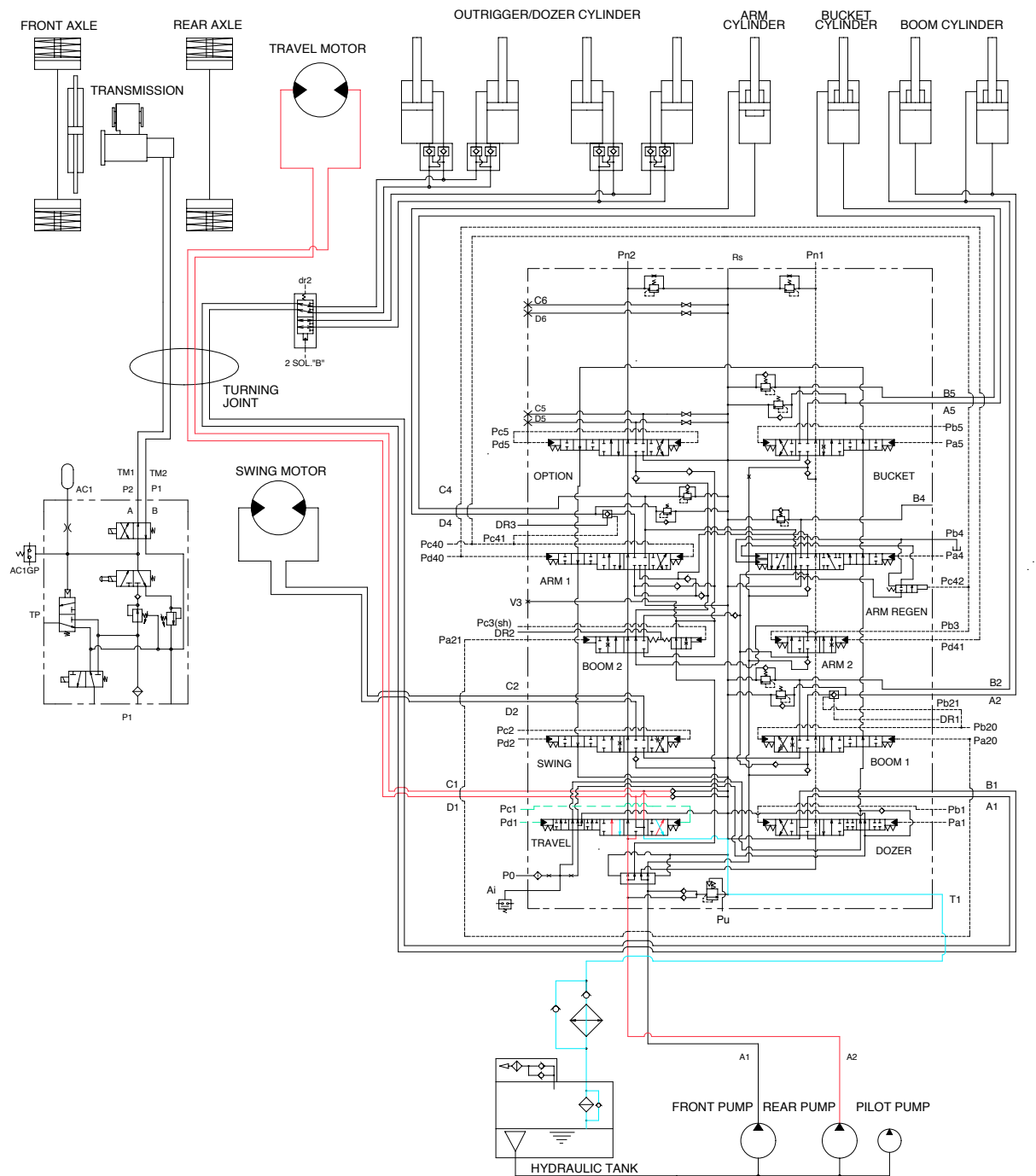

14W73HC17

When the RH multifunction switch is placed in forward or reverse position, the travel spool in the main control valve is moved to the forward or reverse position by the pilot oil pressure from pilot pump through the travel pilot solenoid of transmission control valve and travel Forward/Reverse solenoid valve. The oil from the front pump flows into the main control valve and then goes to the travel motor. At the same time, the oil returned from the travel motor returns to the hydraulic oil tank through the turning joint and travel spool in the main control valve.

When this happens, the machine moves forward or reverse.

The cavitation which will happen to the travel motor is prevented by the make-up valve in the main control valve.

TRAVEL CIRCUIT OPERATION

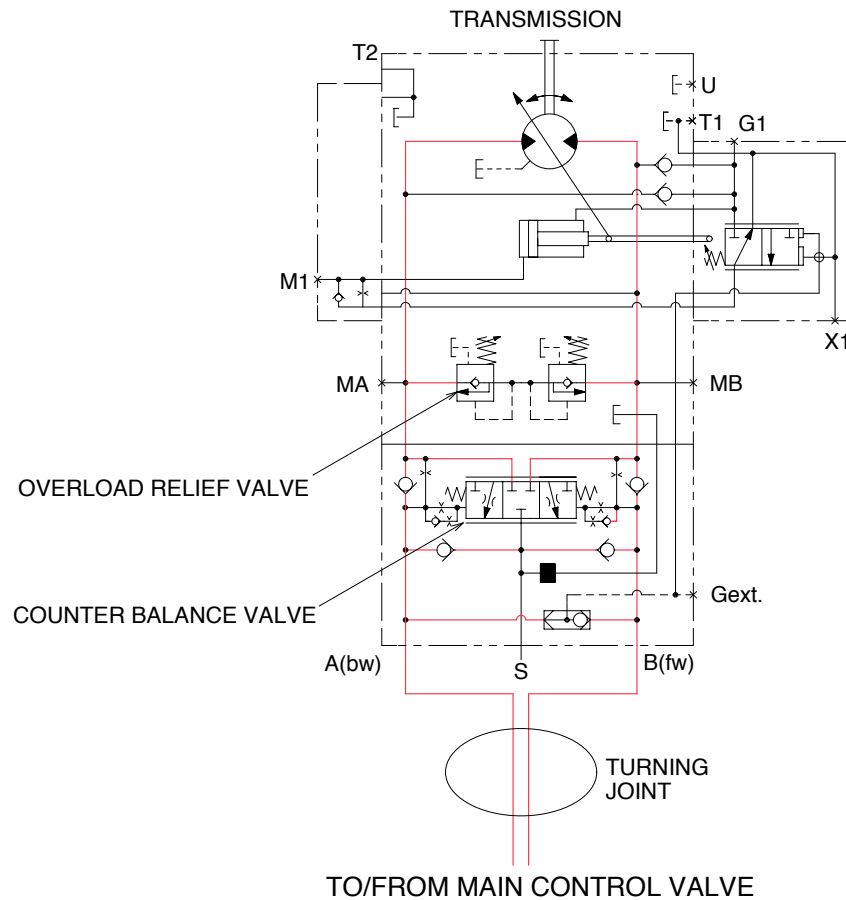

14W73HC18

Valves are provided on travel motor to offer the following functions.

1) COUNTER BALANCE VALVE

When stopping the motor on a slope descending, this valve prevents the motor from over running.

2) OVERLOAD RELIEF VALVE

Relief valve limits the circuit pressure below 350kgf/cm^2 to prevent high pressure from being generated at the time of stopping the machine. When stopping the motor, this valve sucks the oil from lower pressure passage for preventing the negative pressure and the cavitation of the motor.

11. FRONT AND REAR AXLE BRAKE SYSTEM(SERVICE BRAKE)

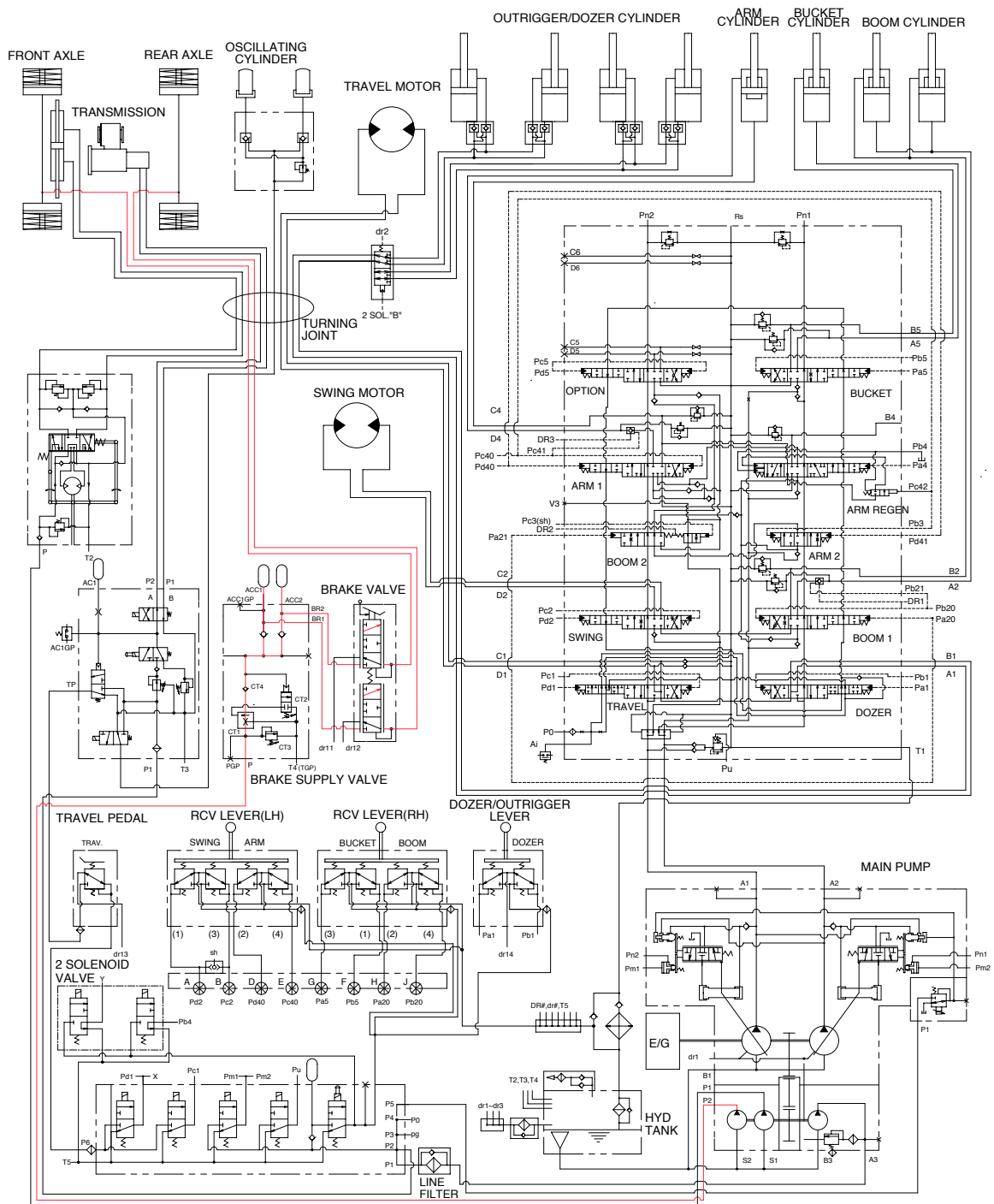

14W73HC21

When the brake pedal(Valve) is pushed, the discharged oil from the gear pump(P2) flows into the front and rear axle brake disc through the solenoid valve of brake supply valve. This pressure is applied to axle brake disc, thus the brake is applied.

12. STEERING CIRCUIT OPERATION

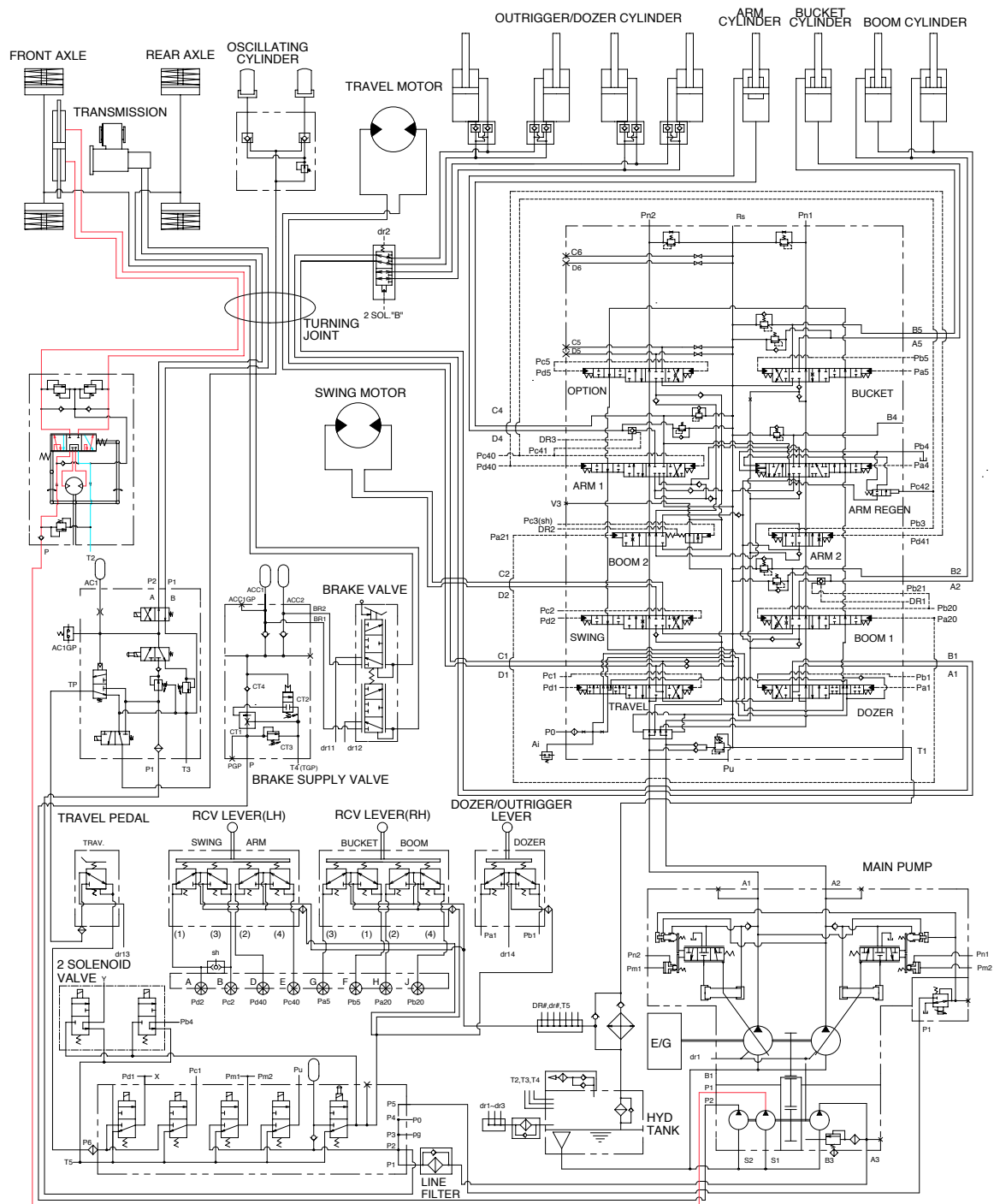

14W73HC22

When the steering wheel is turned to the left or right, the spool within the steering valve turns left or right hand direction : Because the spool is connected with steering column.
 At this time, the oil discharged from the gear pump(P1) flows into steering cylinder through spool and gerotor within the steering valve.
 Then the steering direction is applied.

13. RAM LOCK CIRCUIT OPERATION

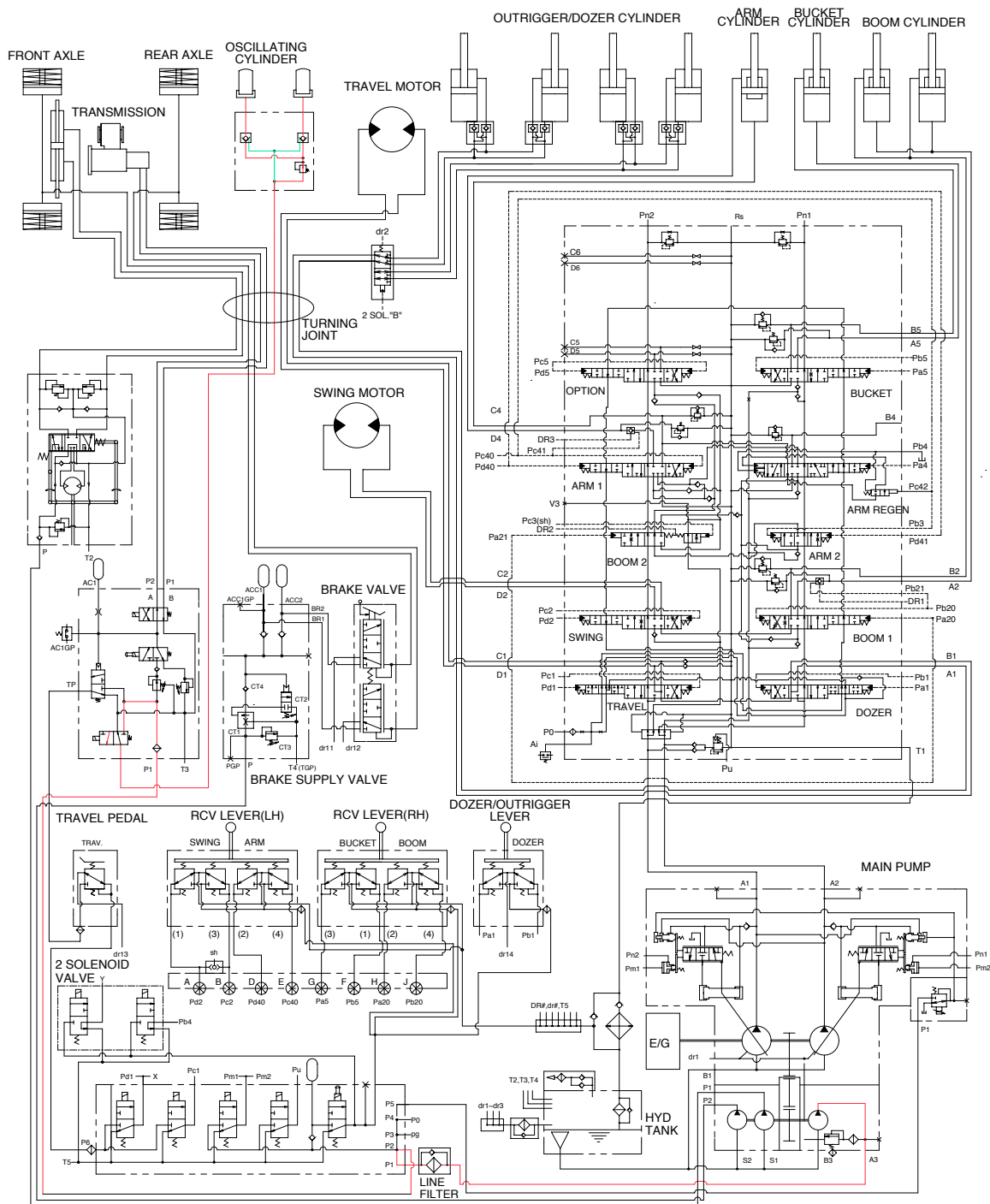

20W73HC23

When the ram lock switch is selected on the switch panel, the ram lock solenoid is changed over. Thus, the oil discharged from the pilot pump flows into oscillating cylinder through ram lock solenoid and locking valve. This pressure is applied to check valve and oscillating cylinder, thus the oscillating function is operated(Ram lock released).

GROUP 5 COMBINED OPERATION

1. OUTLINE

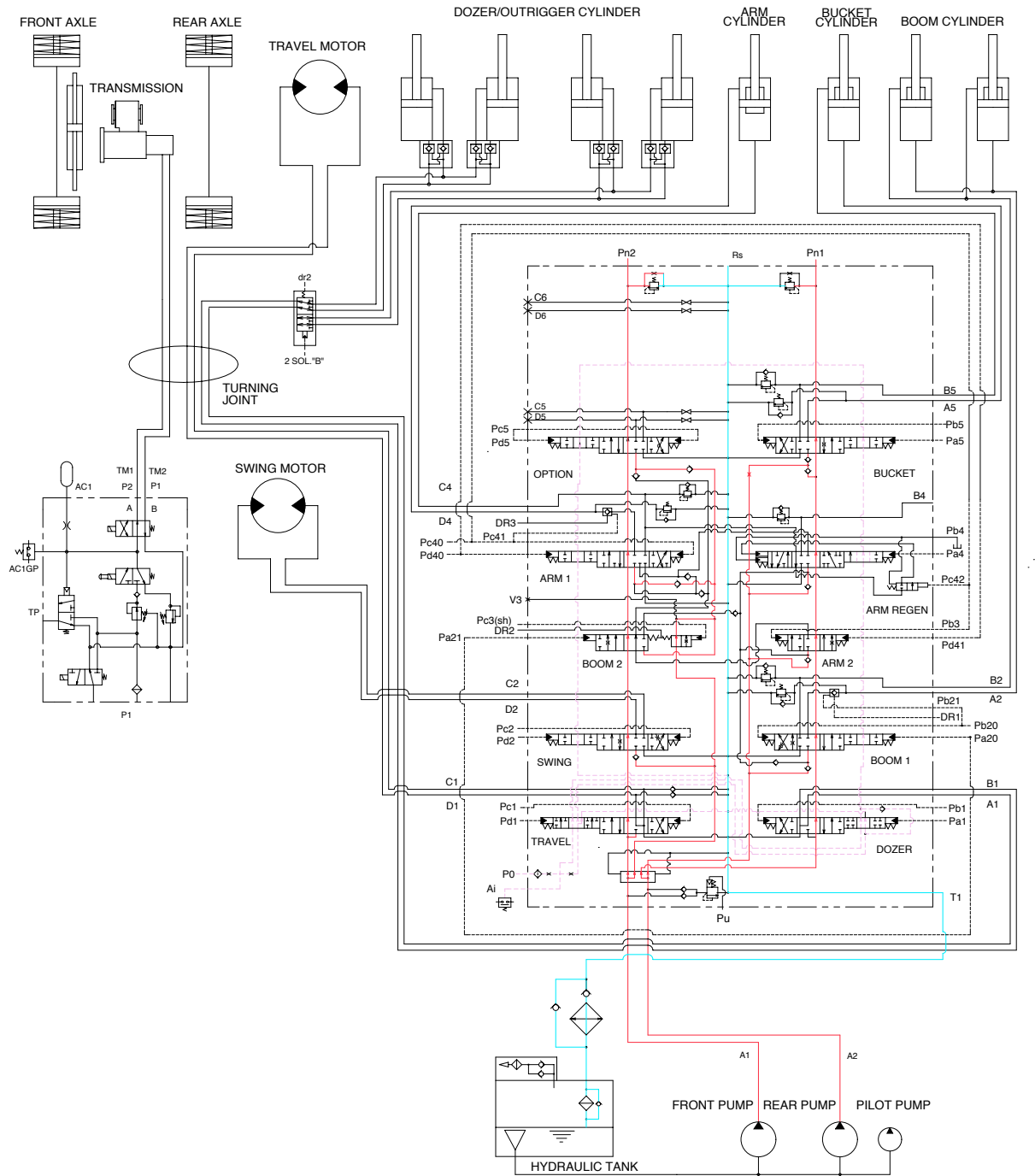

14W73HC24

The oil from the front and rear pump flows through the neutral oil passage, bypass oil passage and confluence oil passage in the main control valve. Then the oil goes to each actuator and operates them. Check valves and orifices are located on these oil passage in the main control valve. These control the oil from the main pumps so as to correspond to the operation of each actuator and smooth the combined operation.

2. COMBINED SWING AND BOOM OPERATION

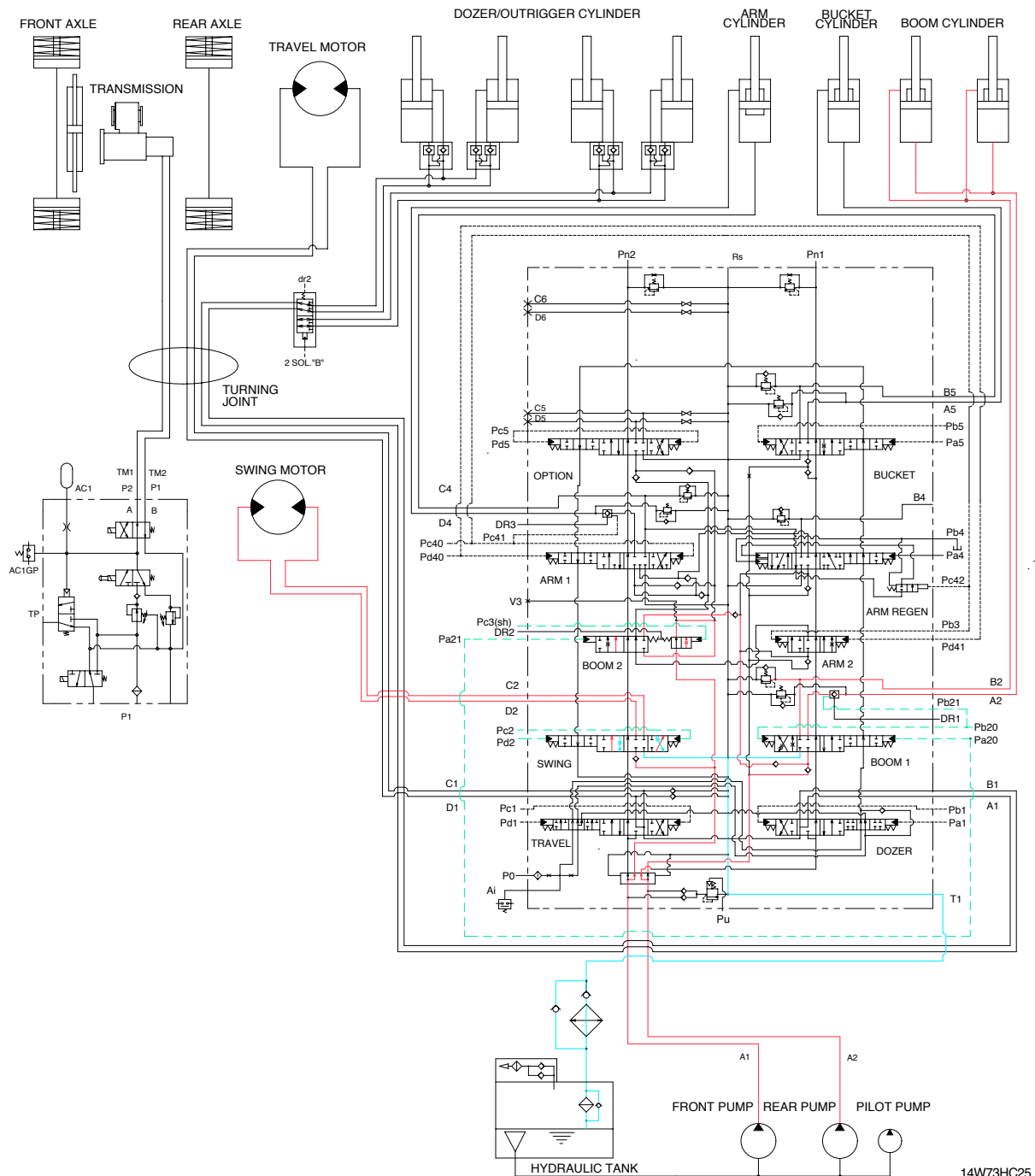

14W73HC25

When the swing and boom functions are operated, simultaneously the swing spool and boom spools in the main control valve are moved to the functional position by the pilot oil pressure from the remote control valve.

The oil from the front pump flows into the swing motor through swing spool and the boom cylinder through boom2 spool.

The oil from the rear pump flows into the boom cylinders through the boom1 spool in the right control valve.

The superstructure swings and the boom is operated.

3. COMBINED SWING AND ARM OPERATION

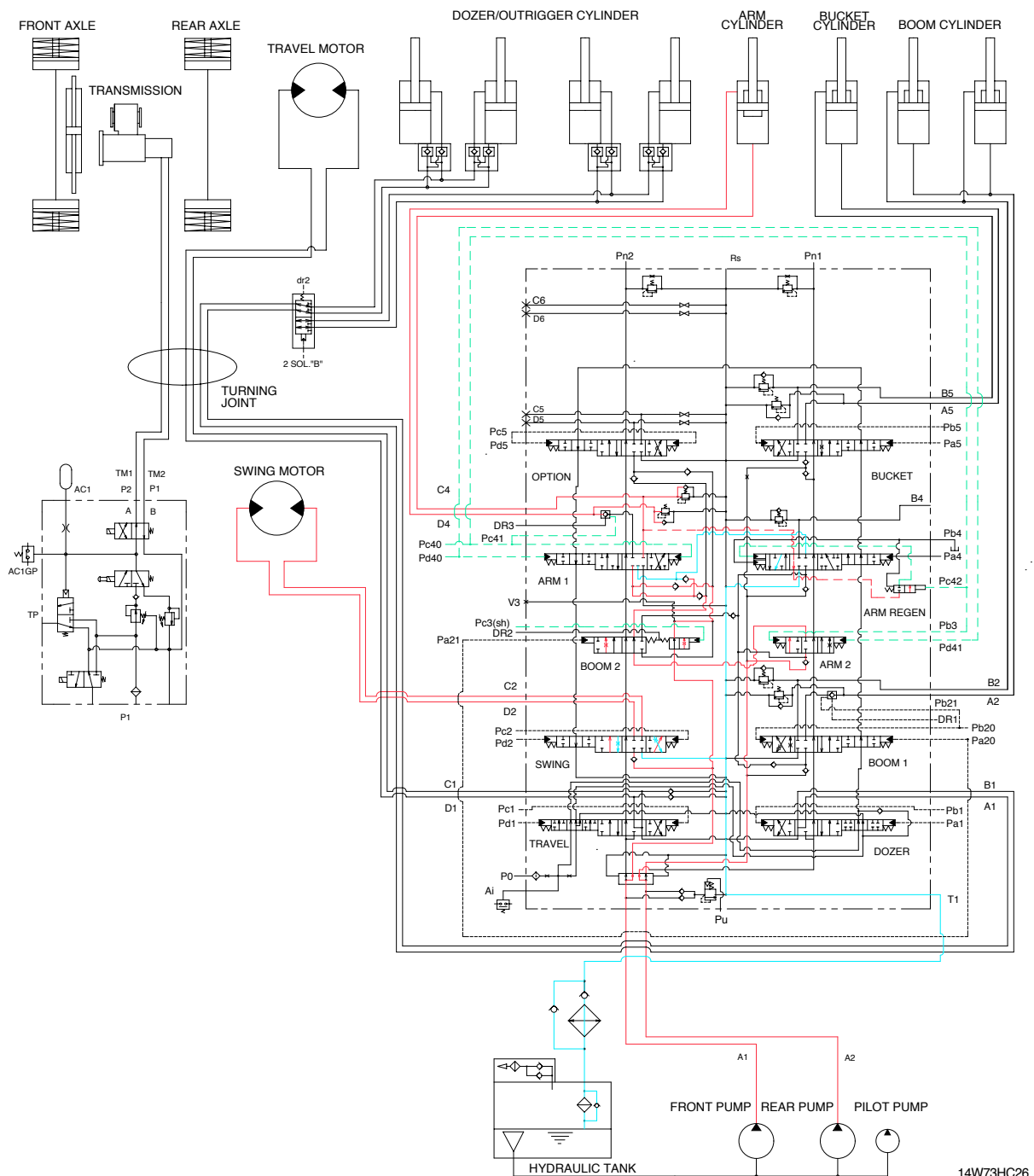

14W73HC26

When the swing and arm functions are operated, simultaneously the swing spool and arm spools in the main control valve are moved to the functional position by the pilot oil pressure from the remote control valve.

The oil from the front pump flows into the swing motor through swing spool and the arm cylinder through arm1 spool.

The oil from the rear pump flows into the arm cylinder through the arm2 spool of the right control valve.

The superstructure swings and the arm is operated.

4. COMBINED SWING AND BUCKET OPERATION

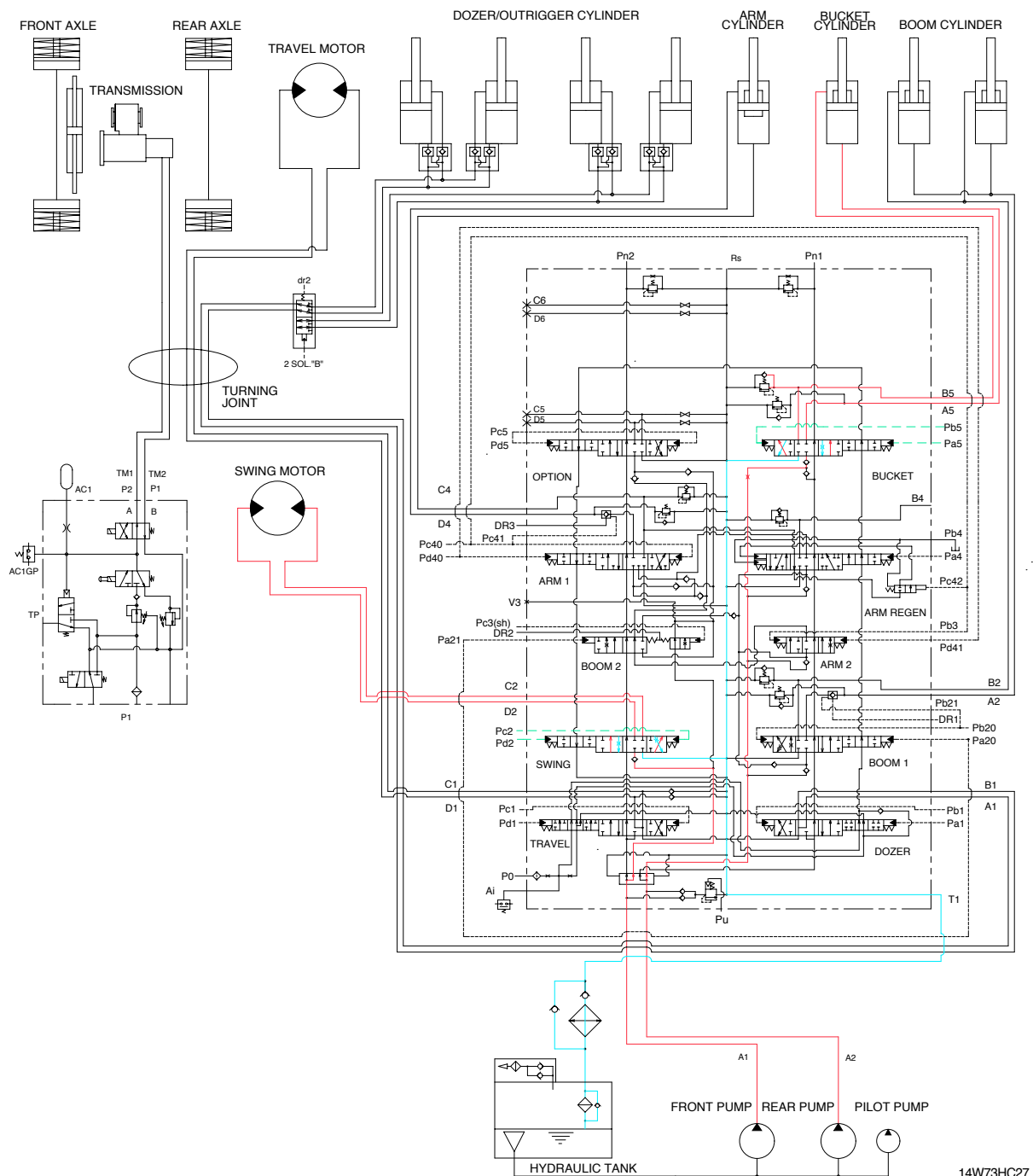

When the swing and bucket functions are operated, simultaneously the swing spool and bucket spool in the main control valve are moved to the functional position by the pilot oil pressure from the remote control valve.

The oil from the front pump flows into the swing motor through the swing spool in the left control valve.

The oil from the rear pump flows into the bucket cylinder through the bucket spool in the right control valve.

The superstructure swings and the bucket is operated.

5. COMBINED SWING, BOOM, ARM AND BUCKET OPERATION

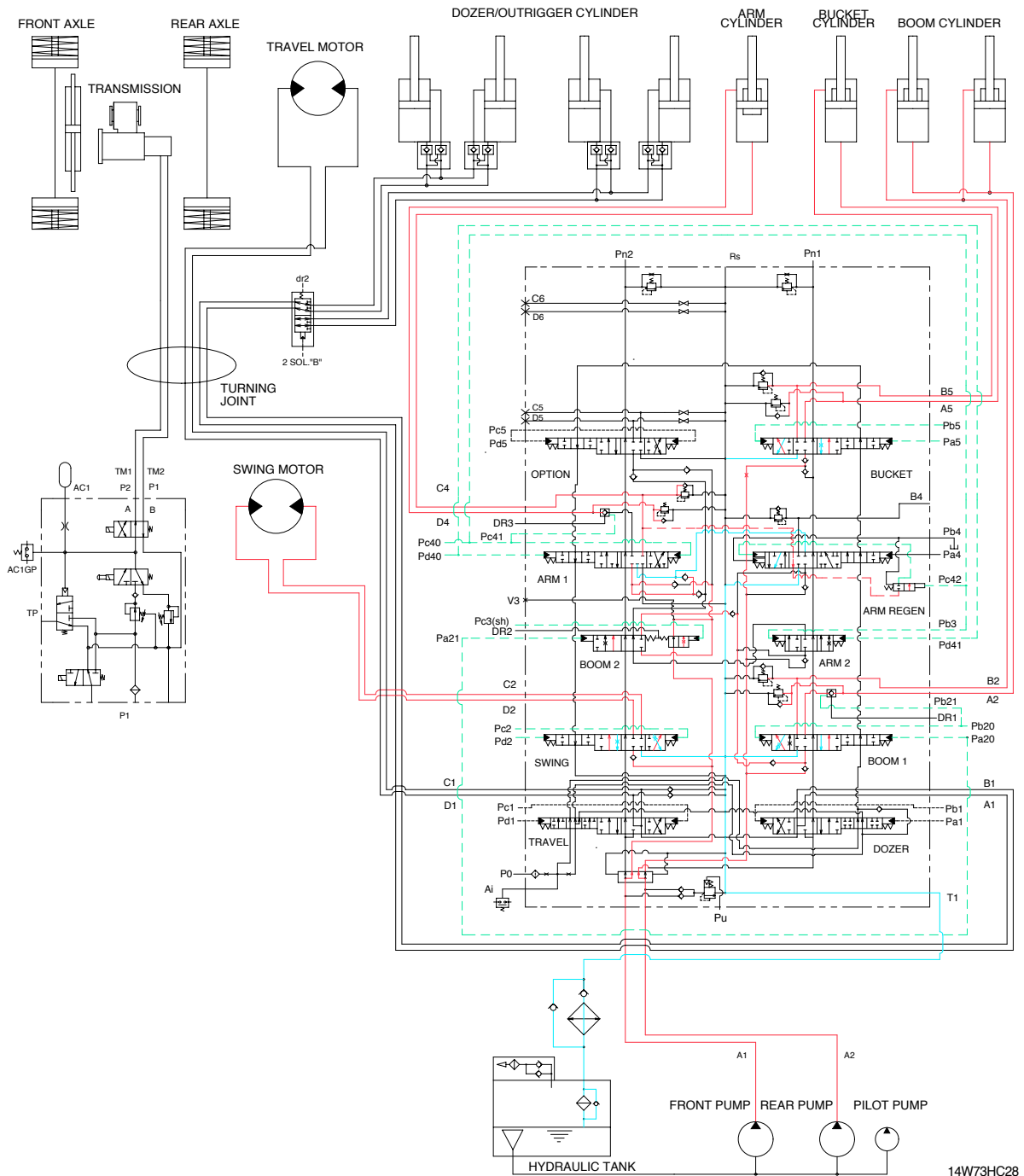

When the swing, boom, arm and bucket functions are operated, simultaneously each spool in the main control valve is moved to the functional position by the pilot oil pressure from the remote control valve.

The oil from the front pump flows into the swing motor, boom cylinders and arm cylinder through the swing spool, boom 2 spool, arm 1 spool, and the parallel and confluence oil passage in the left control valve. The oil from the rear pump flows into the boom cylinders, arm cylinder and bucket cylinder through the boom 1 spool, arm 2 spool, bucket spool and the parallel and confluence oil passage in the right control valve.

The superstructure swings and the boom, arm and bucket are operated.