

GROUP 3 PILOT CIRCUIT

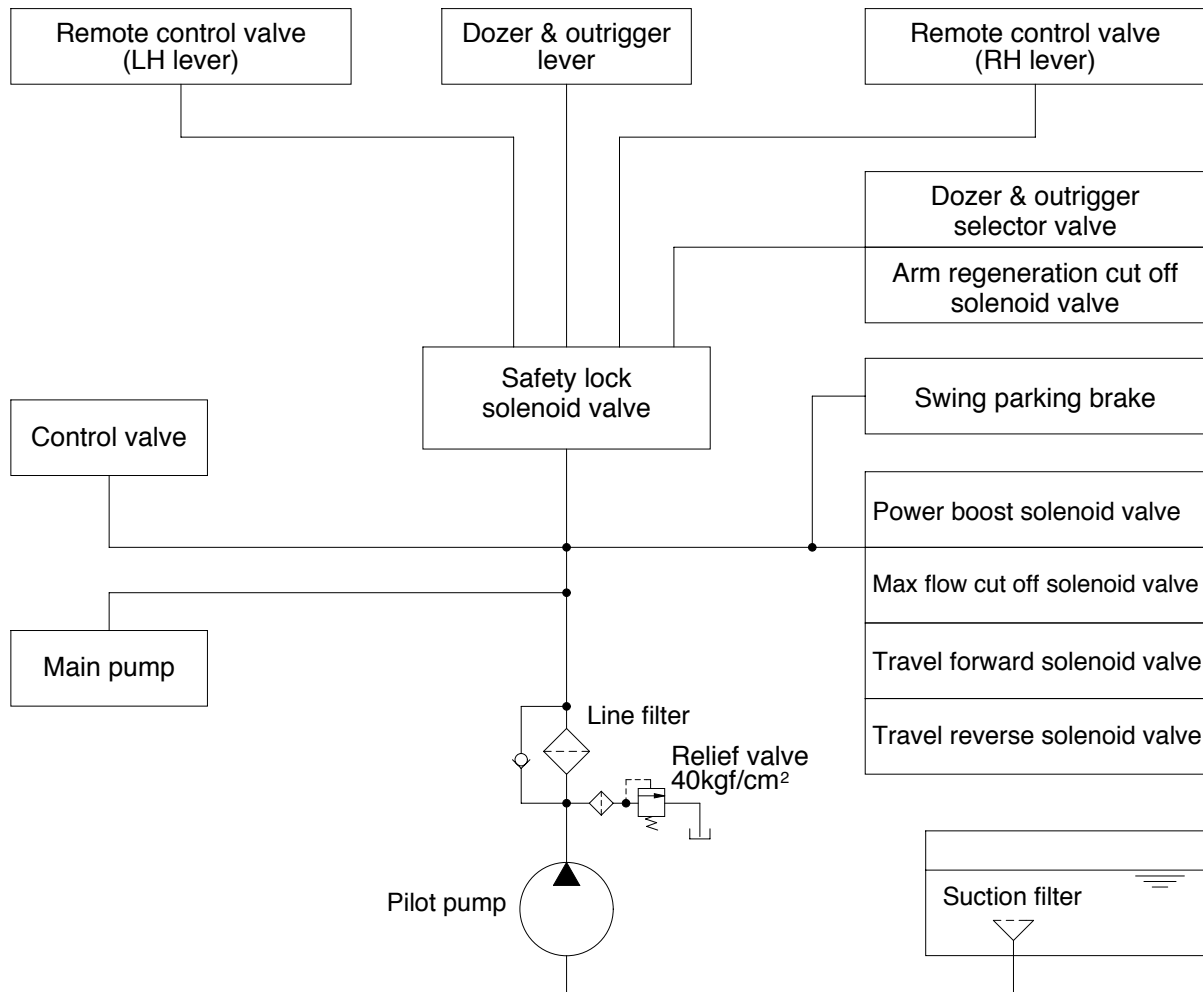

14W73CI03

The pilot circuit consists of suction circuit, delivery circuit and return circuit.

The pilot pump is provided with relief valve, receives the oil from the hydraulic tank through the suction filter.

The discharged oil from the pilot pump flows to the remote control valve, EPPR valve, solenoid valve assemblies, swing parking brake, main control valve and safety lock solenoid valve through line filter.

1. SUCTION, DELIVERY AND RETURN CIRCUIT

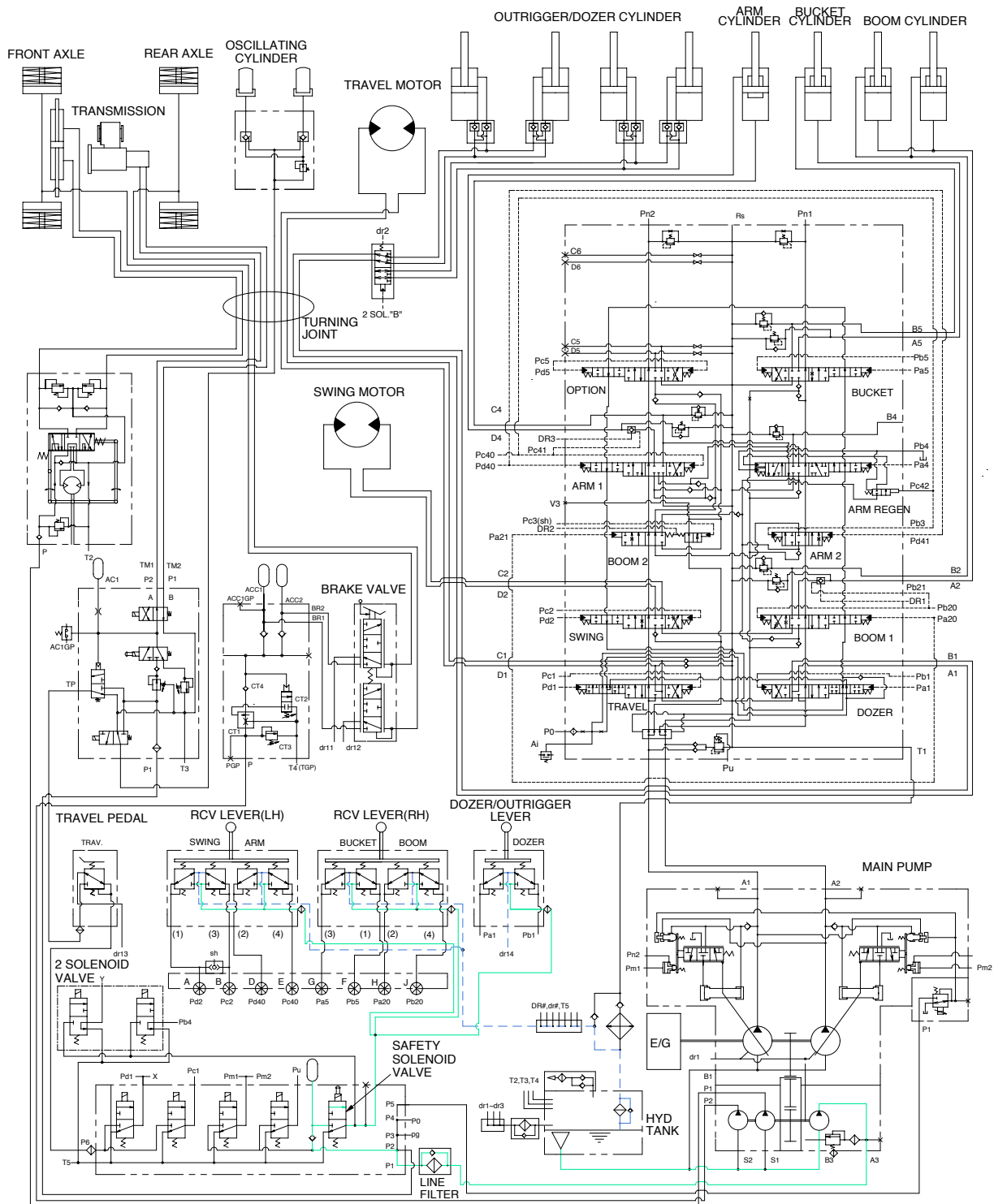

14W73HC02

The pilot pump receives oil from the hydraulic tank. The discharged oil from the pilot pump flows to the safety solenoid valve through the line filter. The oil is filtered by the line filter. The pilot relief valve is provided in the pilot pump for limiting the pilot circuit pressure.

The oil filtered by line filter flows remote control valve through safety solenoid valve.

The return oil from remote control valve is returned to the hydraulic tank.

2. SAFETY SOLENOID VALVE(SAFETY LEVER)

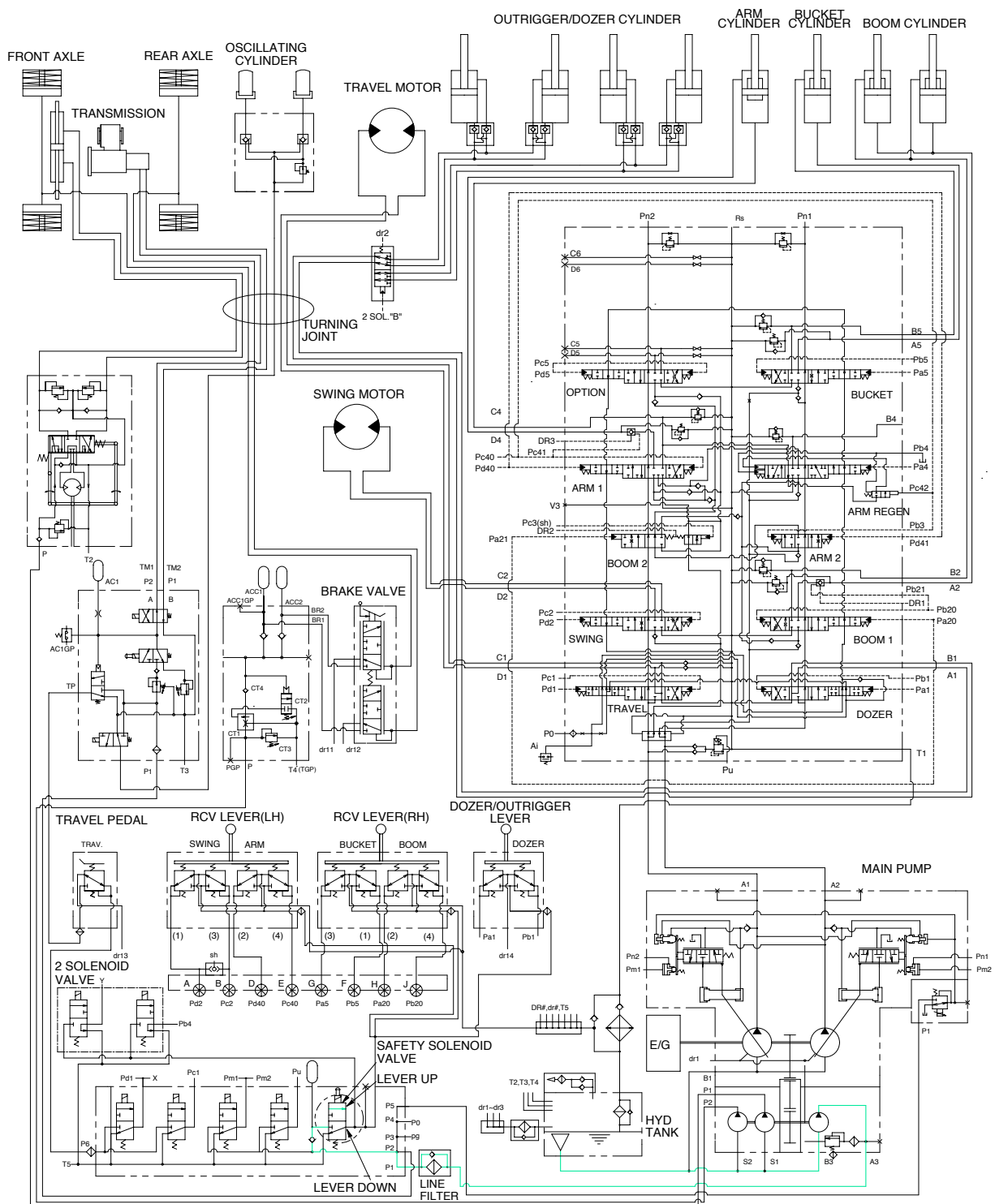

14W73HC03

When the lever of the safety solenoid valve is moved upward, oil flows into the remote control valve through solenoid valve and line filter.

When the lever of the safety solenoid valve moved downward, oil does not flows into the remote control valve, because of blocked port.

3. MAIN RELIEF PRESSURE CHANGE SYSTEM

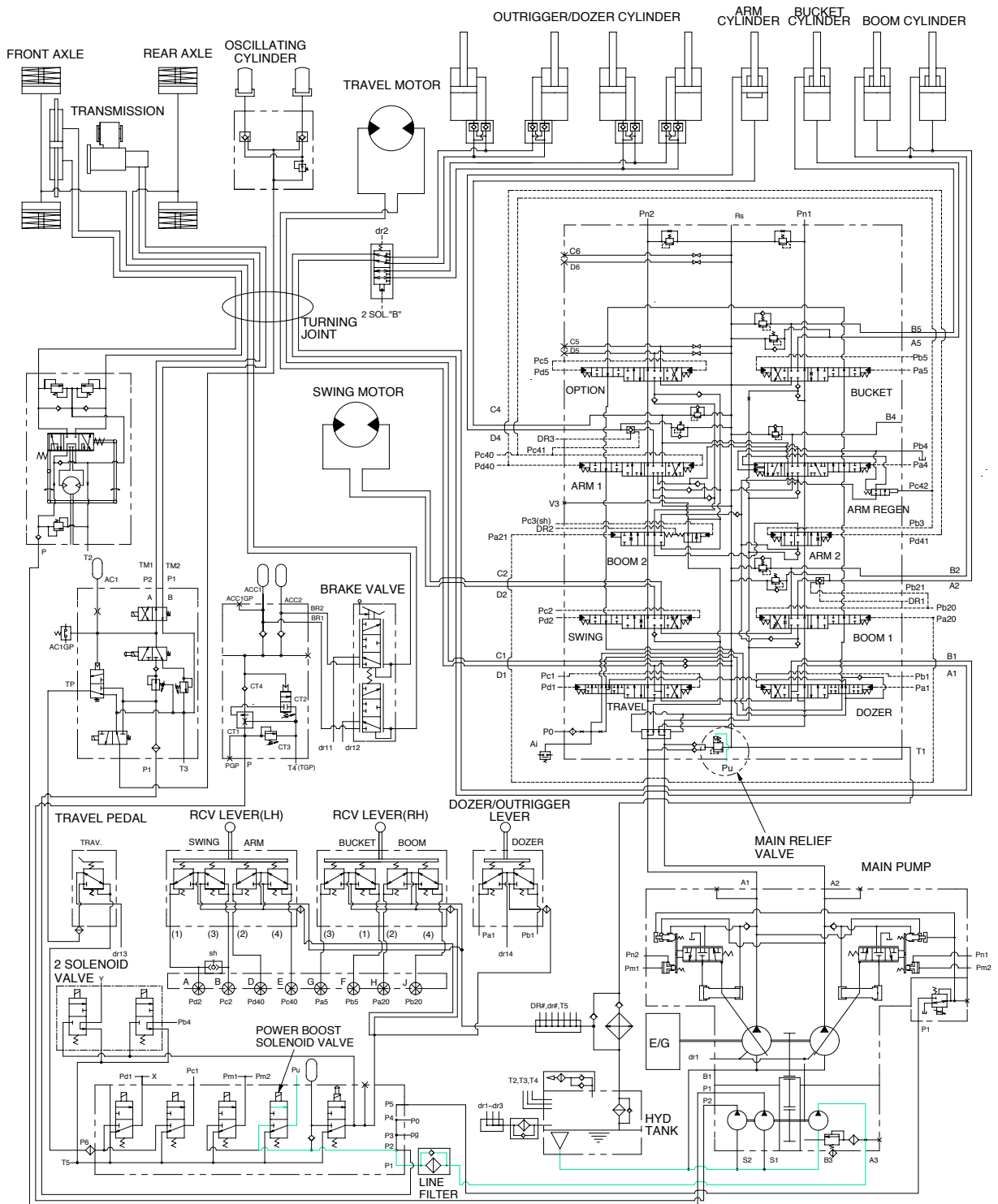

14W73HC04

When the power boost switch on the left control lever is pushed ON, the power max solenoid valve is actuated, the discharged oil from the pilot pump into Pu port of the main relief valve in main control valve ; Then the setting pressure of the main relief valve is raises from 330kgf/cm² to 360kgf/cm² for increasing the digging power. And even when press continuously, it is canceled after 8 seconds.

4. SWING PARKING BRAKE RELEASE

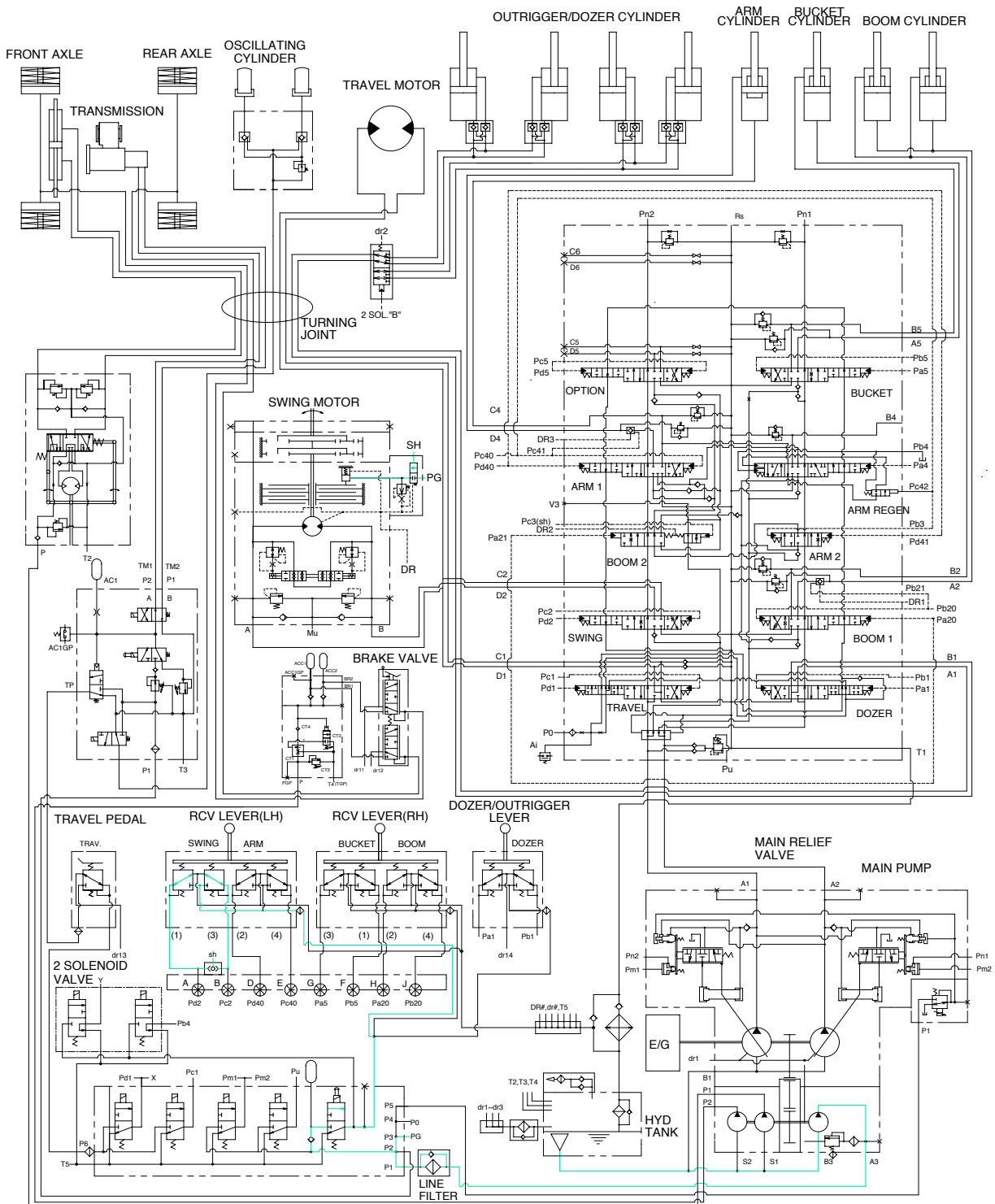

14W73HC05

When the swing control lever is operated, the pilot oil flow into SH port of shuttle valve, this pressure move spool so, discharged oil from pilot pump flow into PG port.

This pressure is applied to swing motor disc, thus the brake released.

When the swing control lever is set neutral position, oil in the swing motor disc cylinder is drain, thus the brake is applied.

5. TRAVEL SPEED SELECTION SYSTEM

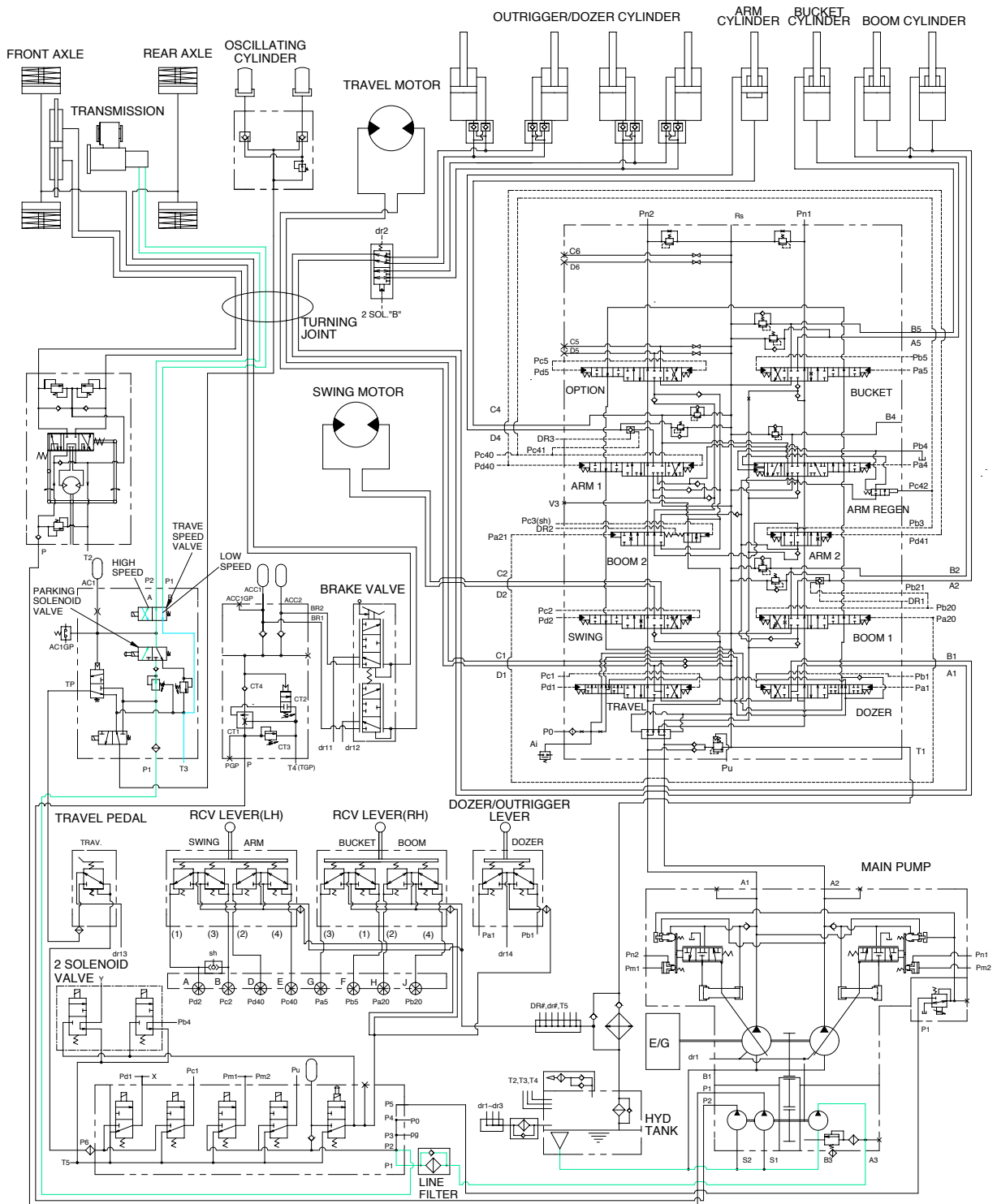

14W73HC06

When RH multifunction switch was placed in high or low position, the pressure oil from pilot pump flows through parking solenoid valve of transmission control valve to travel speed solenoid valve, thus the transmission is changed into high or low speed condition.

6. MAX FLOW CUT OFF SYSTEM

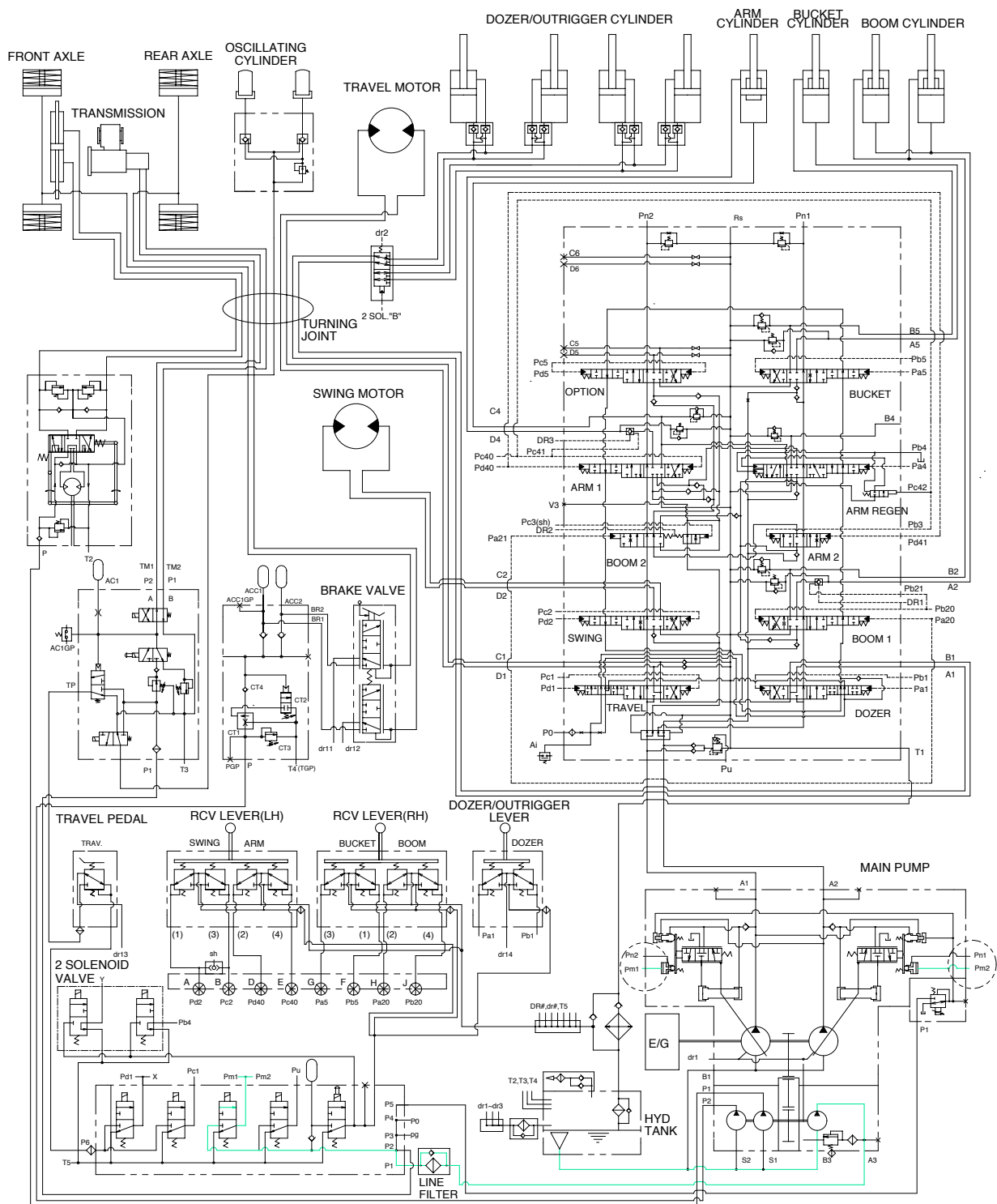

14W73HC07

When the breaker operation mode is selected on the cluster, max flow cut off solenoid valve actuates automatically.

Thus pilot pressure(Pm1,2) is sent to the regulator and pump discharge volume is decreased.

7. ARM REGENERATION CUT OFF SYSTEM

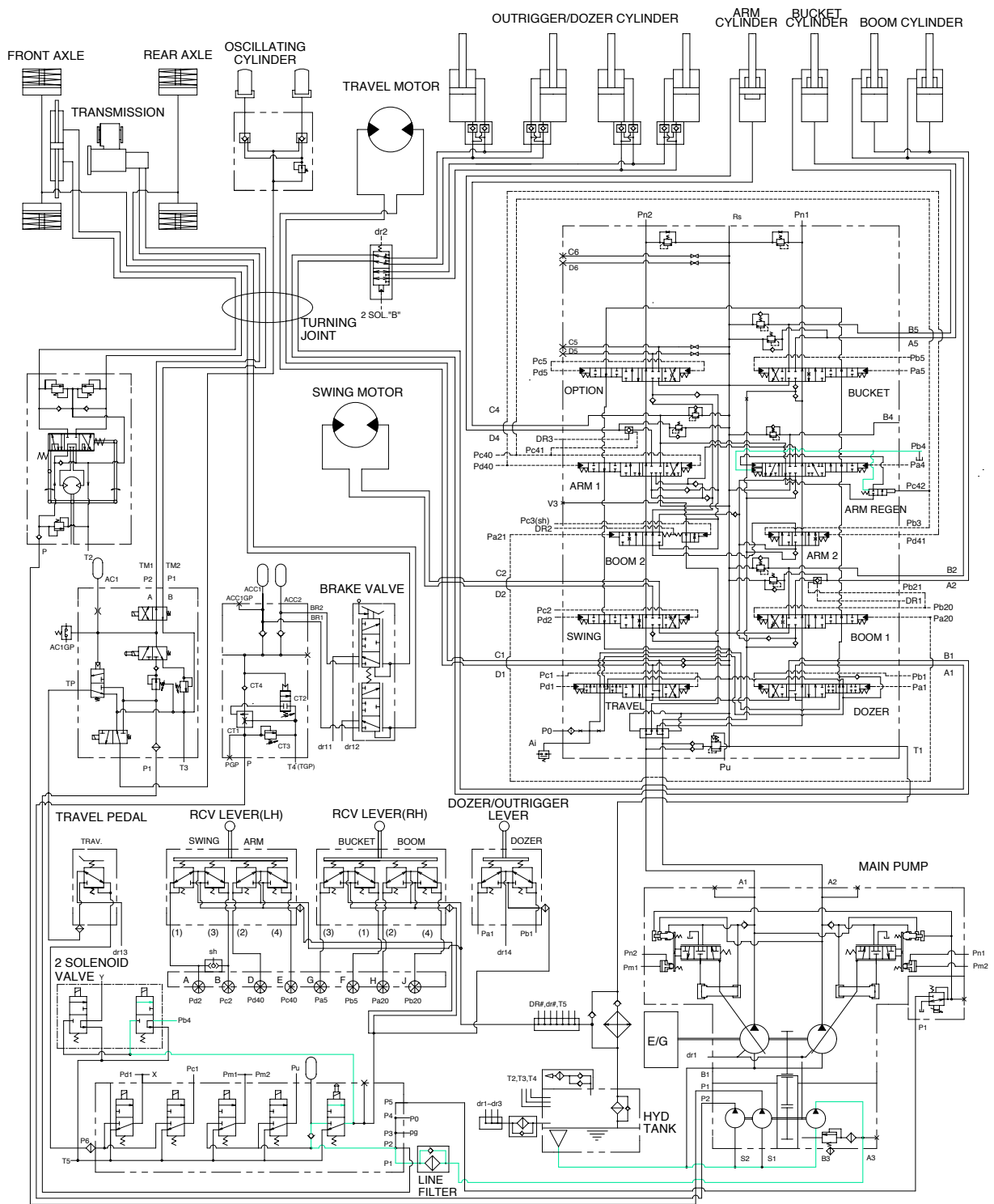

14W73HC08

When the heavy duty mode switch on the cluster is pushed ON, the arm regeneration solenoid valve is deactivated and the arm regeneration spool is returned to neutral position.

The arm regeneration function is activated.

Then, arm operation speed is increased.