

GROUP 3 ELECTRICAL SYSTEM

1. WHEN STARTING SWITCH IS TURNED ON, MONITOR PANEL DISPLAY DOES NOT APPEAR

- Before disconnecting the connector, always turn the starting switch OFF.
- Before carrying out below procedure, check all the related connectors are properly inserted and fuse No.7 and 13 burnt out.
- After checking, insert the disconnected connectors again immediately unless otherwise specified.

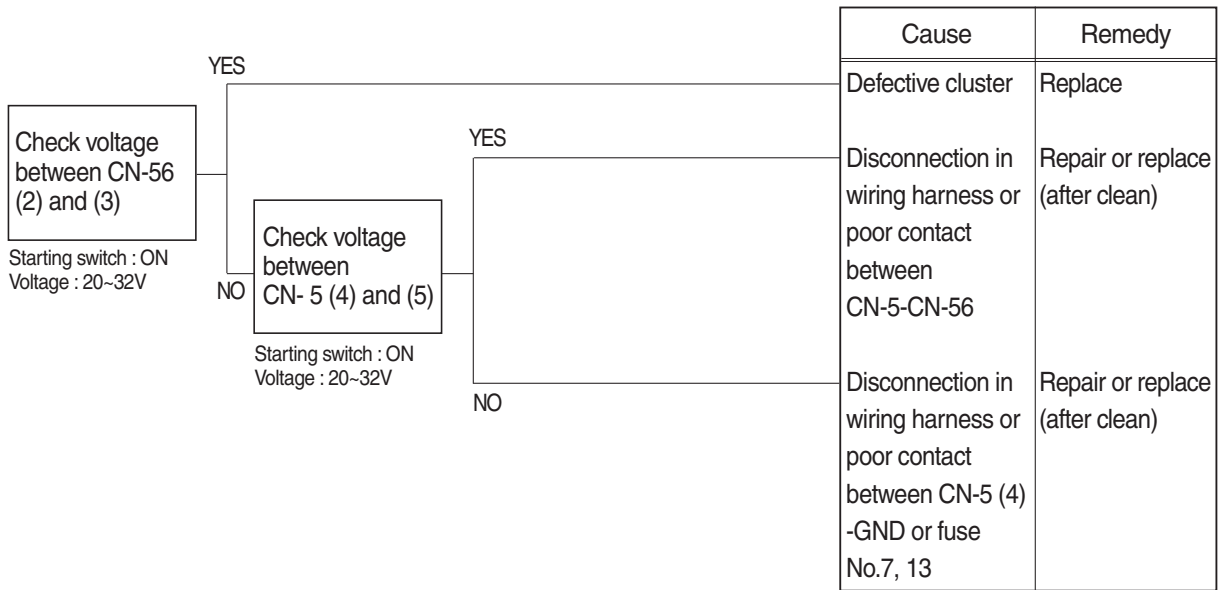

Check voltage

YES	20~32V
NO	0V

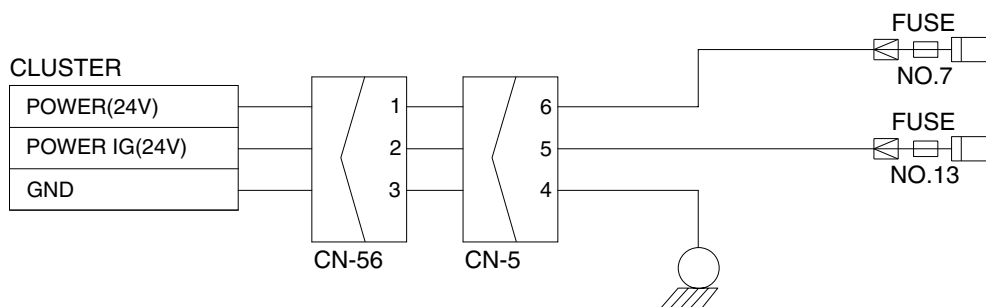

14096ES01

2. COMMUNICATION ERROR FLASHES ON THE CLUSTER (HCESPN 840, FMI 2)

- Before disconnecting the connector, always turn the starting switch OFF.
- Before carrying out below procedure, check all the related connectors are properly inserted.
- After checking, insert the disconnected connectors again immediately unless otherwise specified.

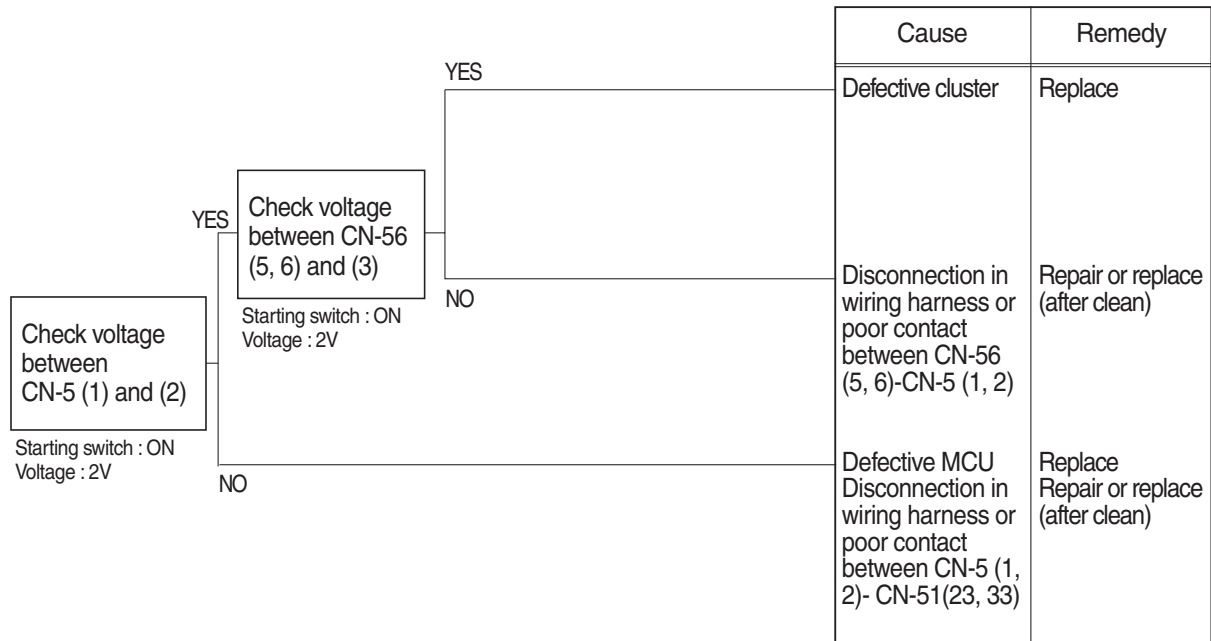

Check voltage

YES	2V
NO	0V

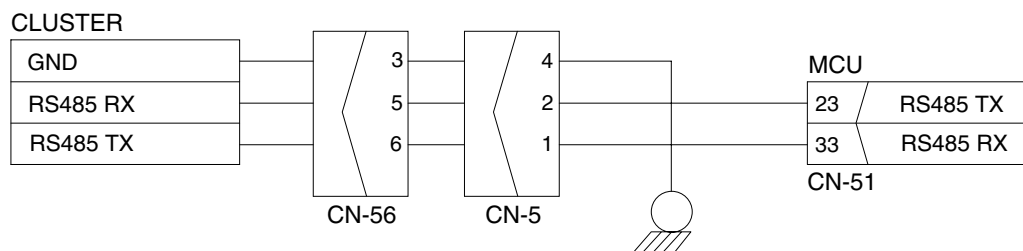

3. BATTERY CHARGING WARNING LAMP LIGHTS UP (Starting switch : ON)

- Before disconnecting the connector, always turn the starting switch OFF.
- Before carrying out below procedure, check all the related connectors are properly inserted.
- After checking, insert the disconnected connectors again immediately unless otherwise specified.

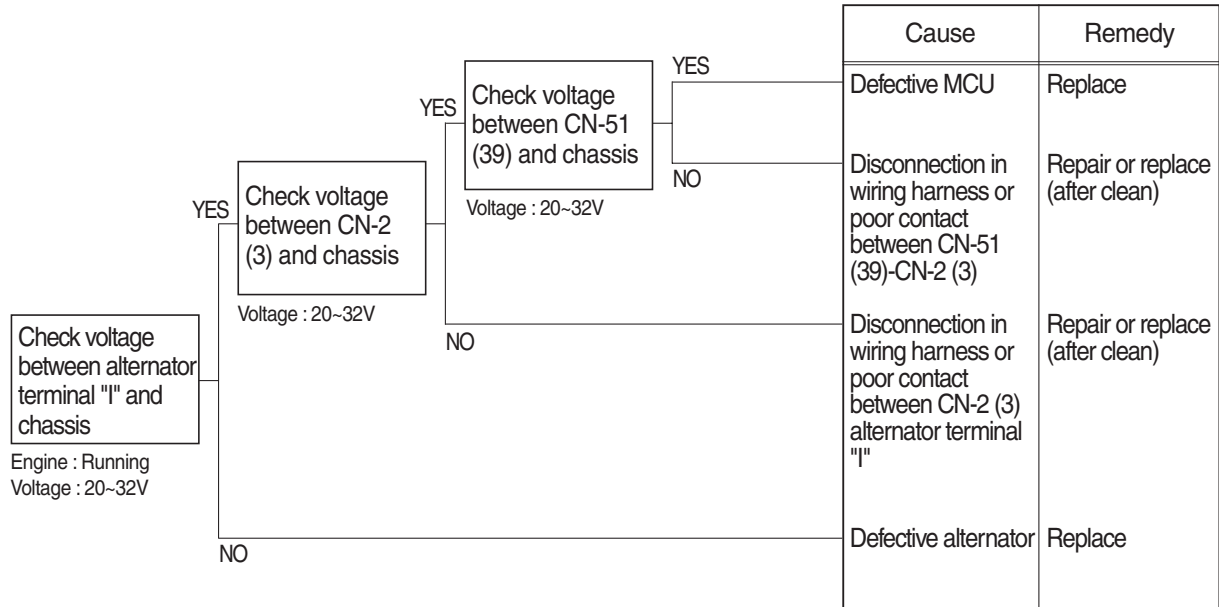

Check voltage

YES	20~32V
NO	0V

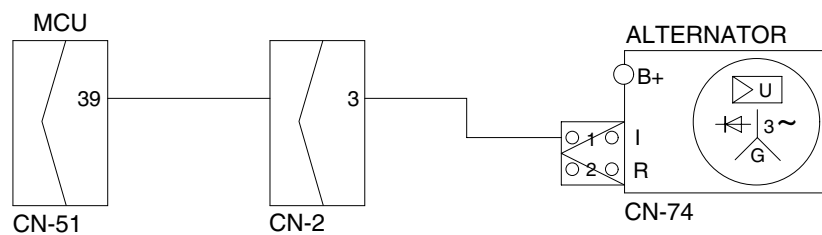

14096ES03

4. WHEN COOLANT OVERHEAT WARNING LAMP LIGHTS UP (engine is started)

- Before disconnecting the connector, always turn the starting switch OFF.
- Before carrying out below procedure, check all the related connectors are properly inserted.
- After checking, insert the disconnected connectors again immediately unless otherwise specified.

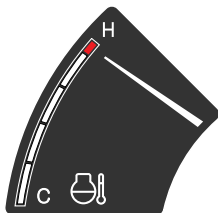
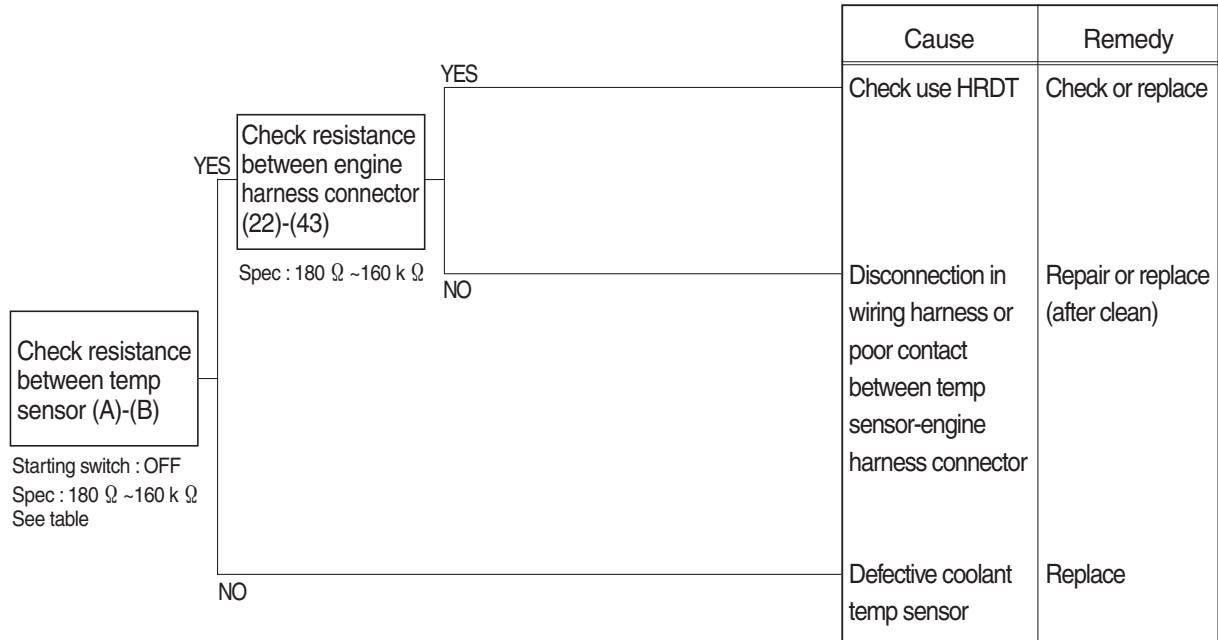

Check Table

Temperature (°C)	0	25	50	80	95
Resistance (kΩ)	30~37	9.3~10.7	3.2~3.8	1.0~1.3	0.7~0.8

SERVICE TOOL

RS232 P_DUMP	A
RS232_RX	B
RS232_TX	C
GND	D
CAN A-(j1939)	E
CAN A+(j1939)	F
Data Link +	G
Data Link -	H
Batt Power B+	J

CN-126

RESISTOR

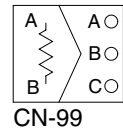

CN-99

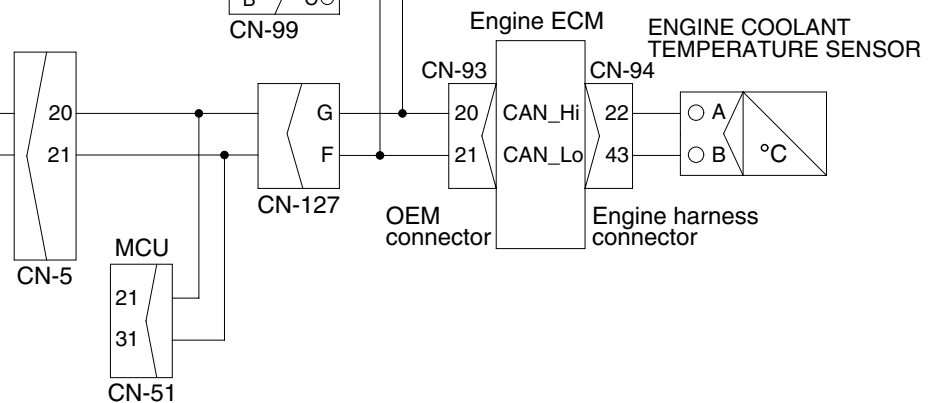

14096ES04

5.  **WHEN AIR CLEANER WARNING LAMP LIGHTS UP** (engine is started)

- Before disconnecting the connector, always turn the starting switch OFF.
- Before carrying out below procedure, check all the related connectors are properly inserted.
- After checking, insert the disconnected connectors again immediately unless otherwise specified.

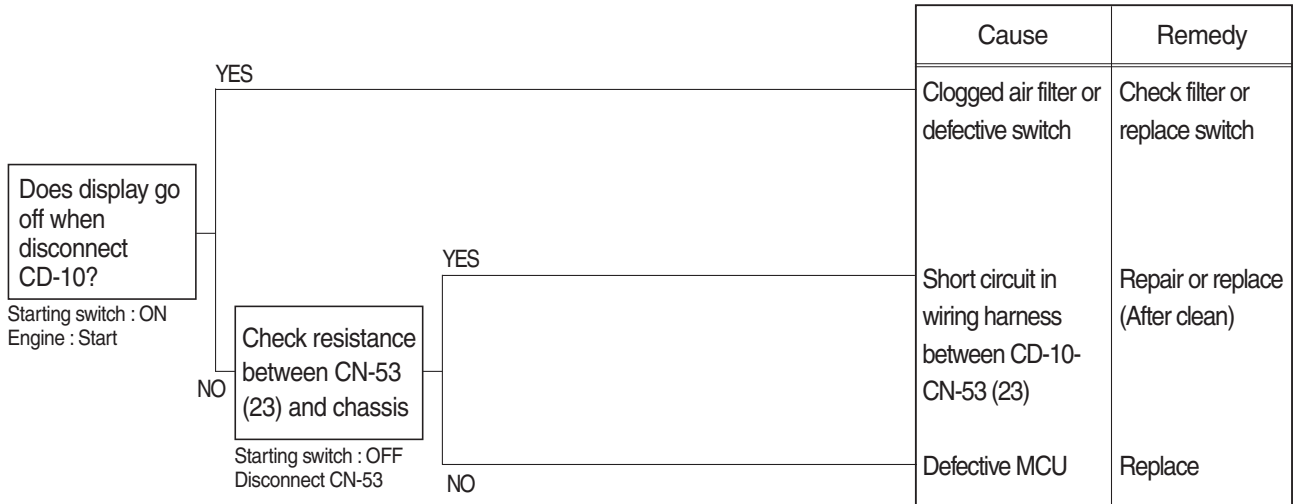

Check resistance

YES	MAX 1Ω
NO	MIN 1MΩ

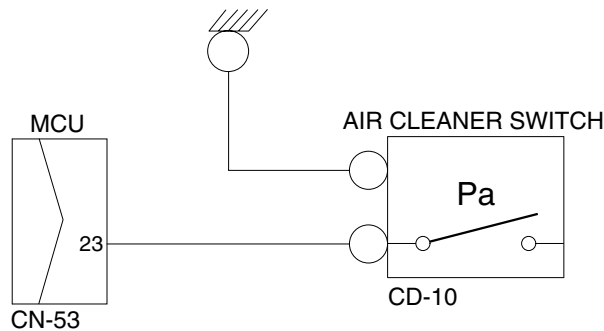

21096ES05

6. WHEN ENGINE OIL PRESSURE WARNING LAMP LIGHTS UP (engine is started)

- Before disconnecting the connector, always turn the starting switch OFF.
- Before carrying out below procedure, check all the related connectors are properly inserted.
- After checking, insert the disconnected connectors again immediately unless otherwise specified.

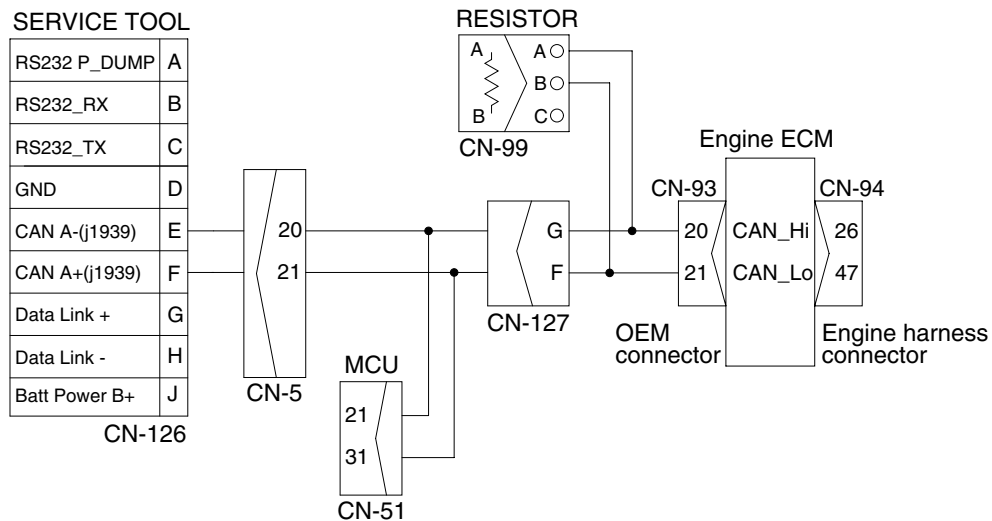
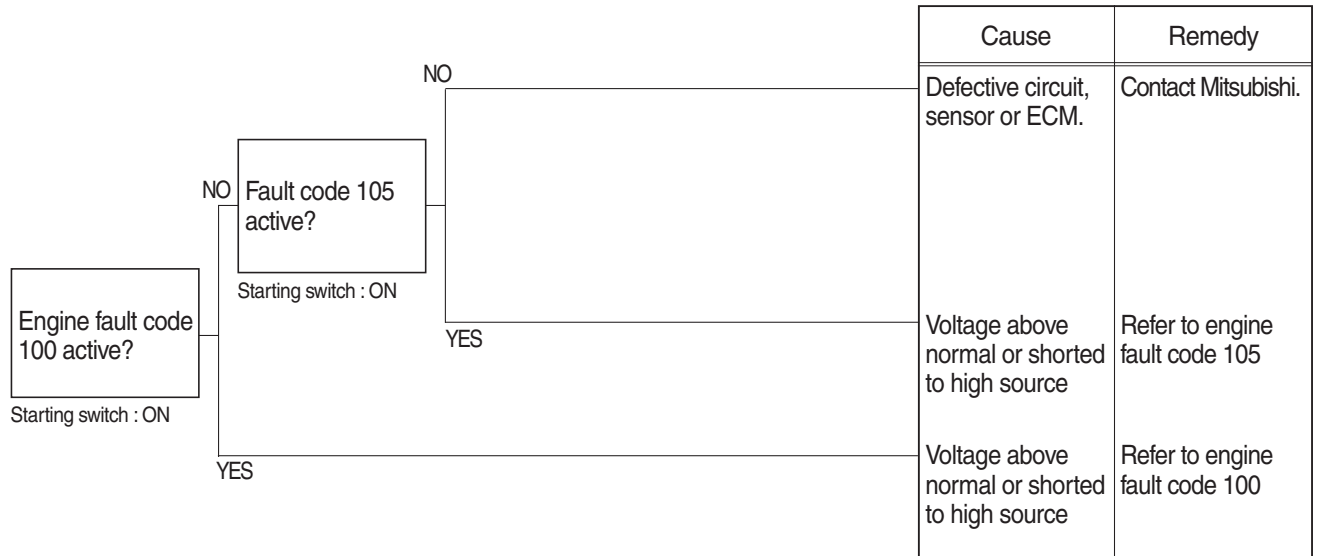

14096ES06

7. WHEN HYDRAULIC OIL TEMPERATURE WARNING LAMP LIGHTS UP (engine is started)

- Before disconnecting the connector, always turn the starting switch OFF.
- Before carrying out below procedure, check all the related connectors are properly inserted.
- After checking, insert the disconnected connectors again immediately unless otherwise specified.

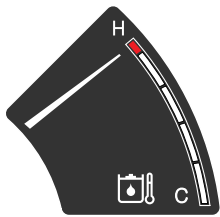
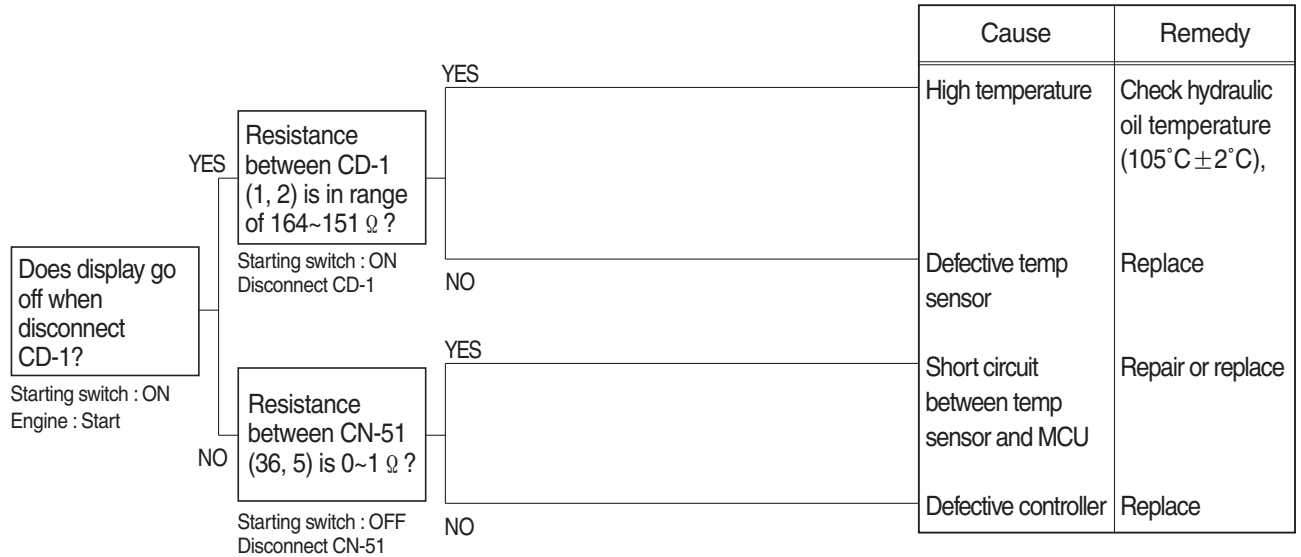

Check Table

Temperature (°C)	~ -30	~ -10	~ 0	~ 40	~ 70	~ 80	~ 90	~ 100	105~
Resistance (k Ω)	22.22 ~31.78	8.16 ~10.74	5.18 ~ 6.6	1.06 ~1.28	0.39 ~0.476	0.322 ~0.298	0.243 ~0.219	0.185 ~0.167	0.164 0.151

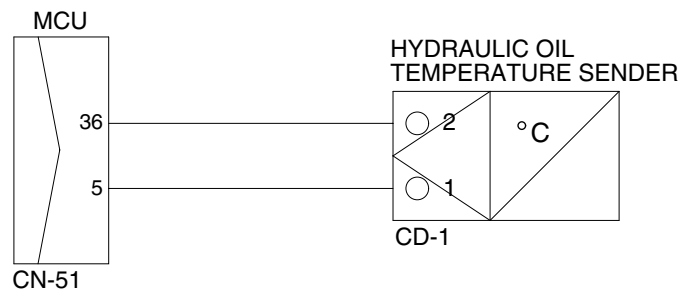

21096ES07

8. WHEN COOLANT TEMPERATURE GAUGE DOES NOT OPERATE (HCESPN 304, FMI 3 or 4)

- Before disconnecting the connector, always turn the starting switch OFF.
- Before carrying out below procedure, check all the related connectors are properly inserted.
- After checking, insert the disconnected connectors again immediately unless otherwise specified.

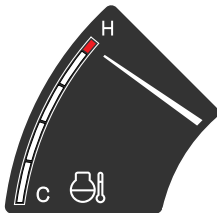
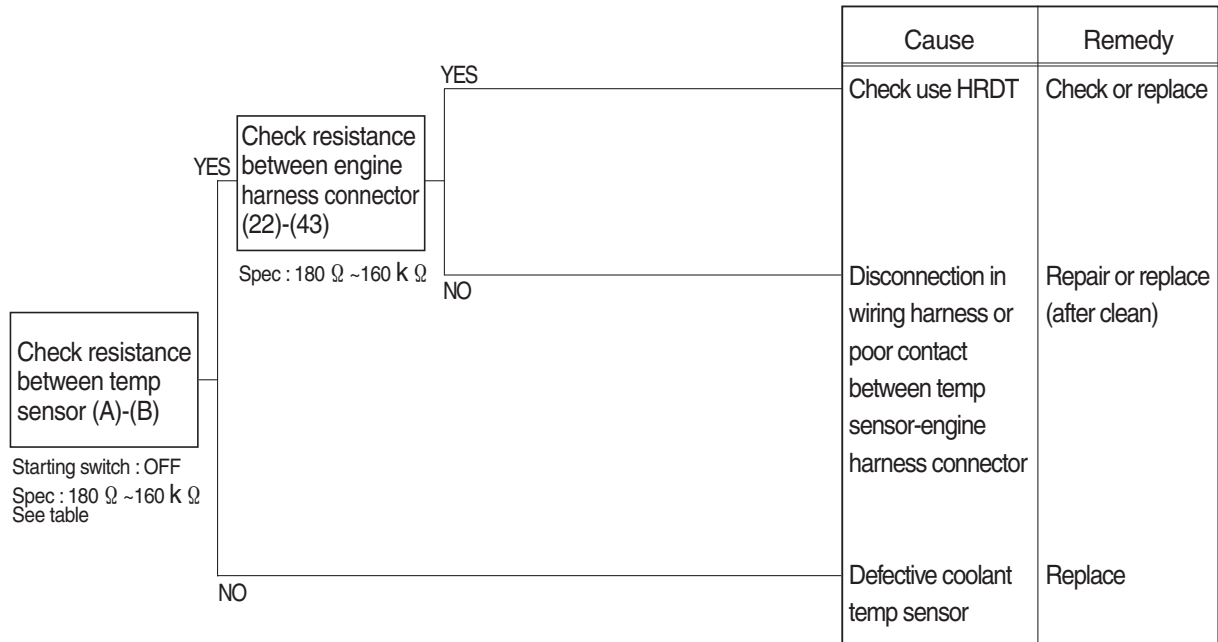

Check Table

Temperature (°C)	0	25	50	80	95
Resistance (k Ω)	30~37	9.3~10.7	3.2~3.8	1.0~1.3	0.7~0.8

SERVICE TOOL

RS232 P_DUMP	A
RS232_RX	B
RS232_TX	C
GND	D
CAN A-(j1939)	E
CAN A+(j1939)	F
Data Link +	G
Data Link -	H
Batt Power B+	J

CN-126

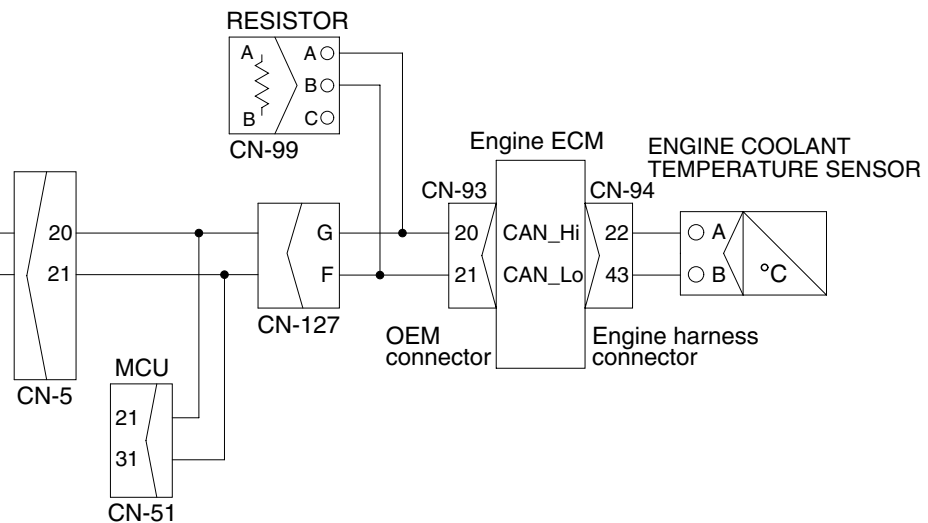

14096ES04

9. WHEN FUEL GAUGE DOES NOT OPERATE(HCESPN 301, FMI 3 or 4)

- Before disconnecting the connector, always turn the starting switch OFF.
- Before carrying out below procedure, check all the related connectors are properly inserted.
- After checking, insert the disconnected connectors again immediately unless otherwise specified.

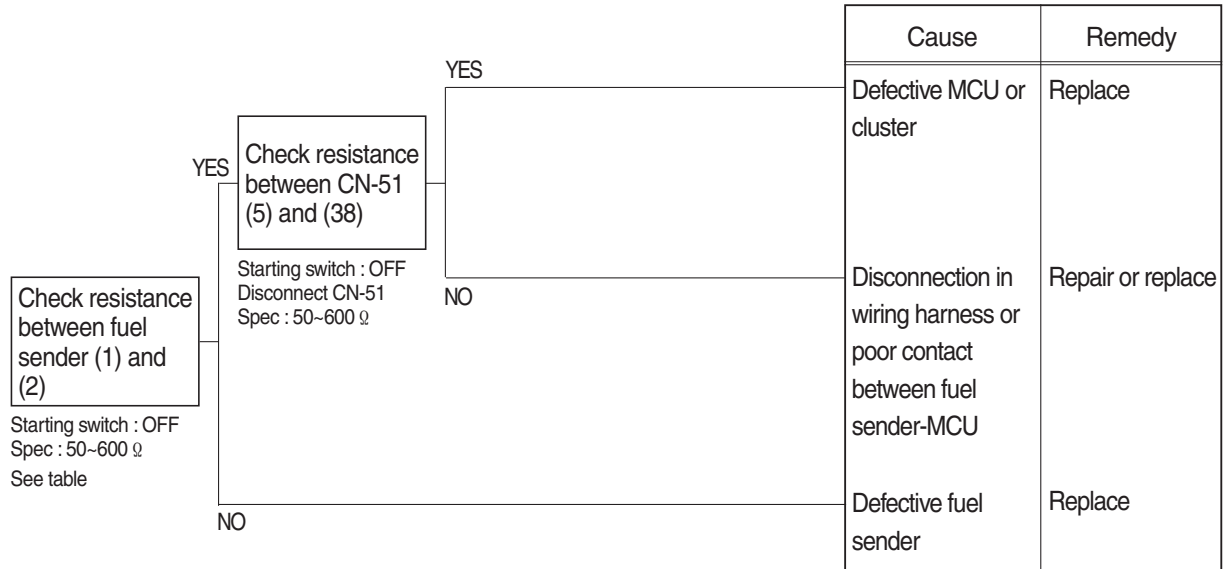

Check Table



Range	Resistance (Ω)	Range	Resistance (Ω)
Full	50	5/12	400
11/12	100	4/12	450
10/12	150	3/12	500
9/12	200	2/12	550
8/12	250	1/12	600
7/12	300	Empty warning	700
6/12	350	-	-

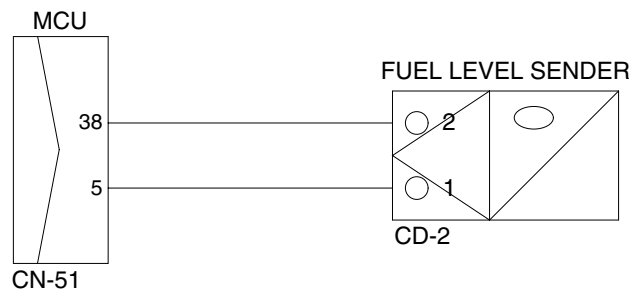

21096ES09

10. WHEN SAFETY SOLENOID DOES NOT OPERATE

- Before disconnecting the connector, always turn the starting switch OFF.
- Before carrying out below procedure, check all the related connectors are properly inserted and fuse No.23 burnt out.
- After checking, insert the disconnected connectors again immediately unless otherwise specified.

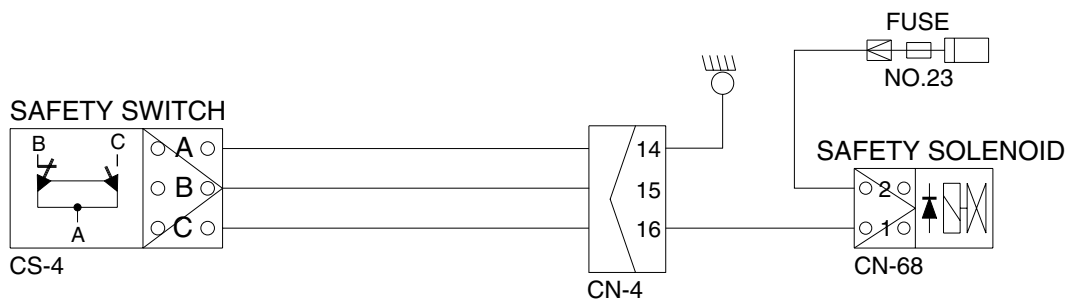
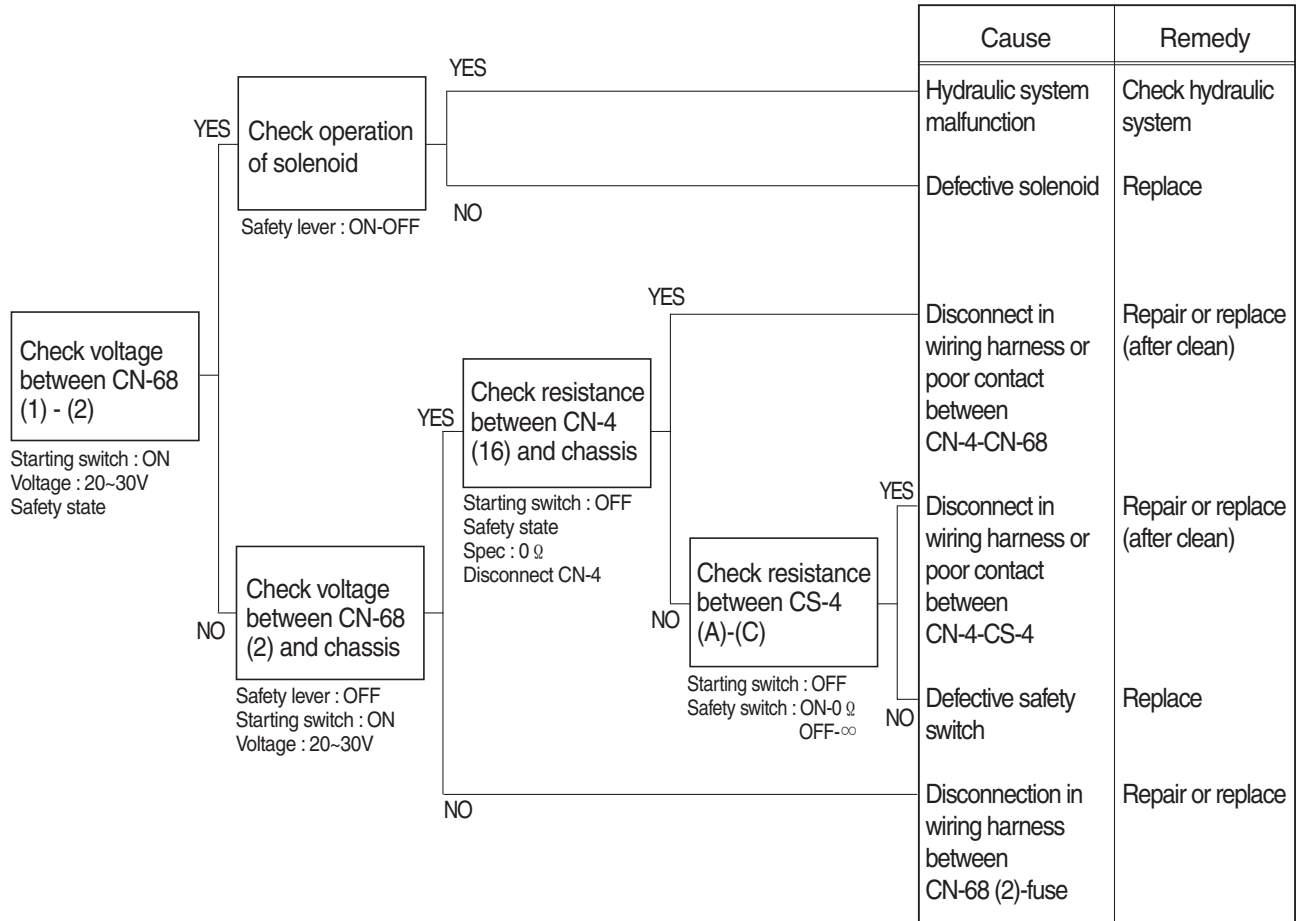

21096ES10

11. WHEN TRAVEL SPEED 1, 2 DOES NOT OPERATE (HCESPN 167, FMI 5 or 6)

- Before disconnecting the connector, always turn the starting switch OFF.
- Before carrying out below procedure, check all the related connectors are properly inserted and fuse No.28 burnt out.
- After checking, insert the disconnected connectors again immediately unless otherwise specified.

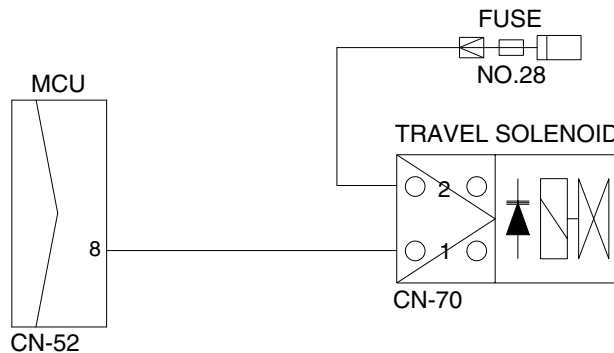
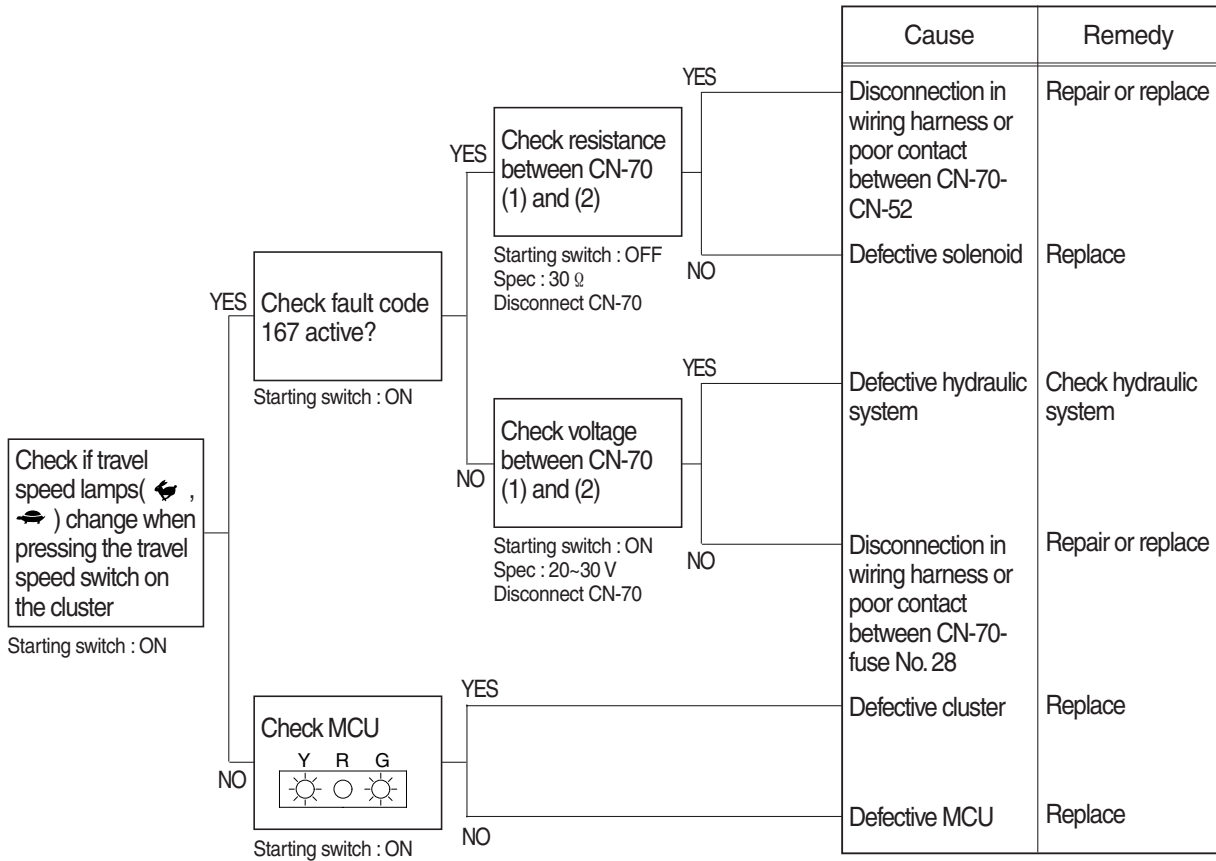

21096ES11

12. WHEN ENGINE DOES NOT START (lights up condition)

- Before disconnecting the connector, always turn the starting switch OFF.
- Before carrying out below procedure, check all the related connectors are properly inserted and fuse No. 1, 4, 8 and 14 burnt out.
- After checking, insert the disconnected connectors again immediately unless otherwise specified.

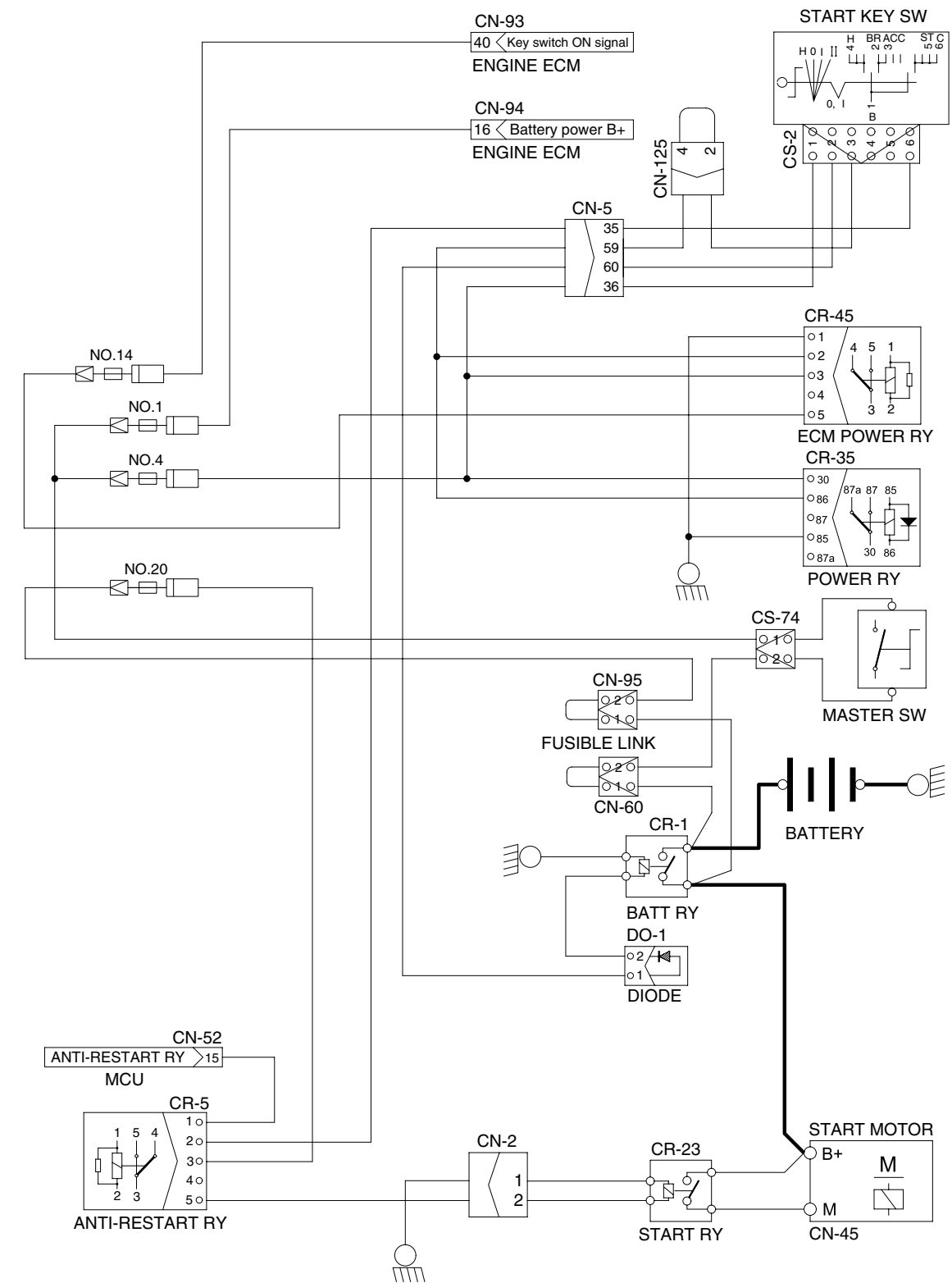
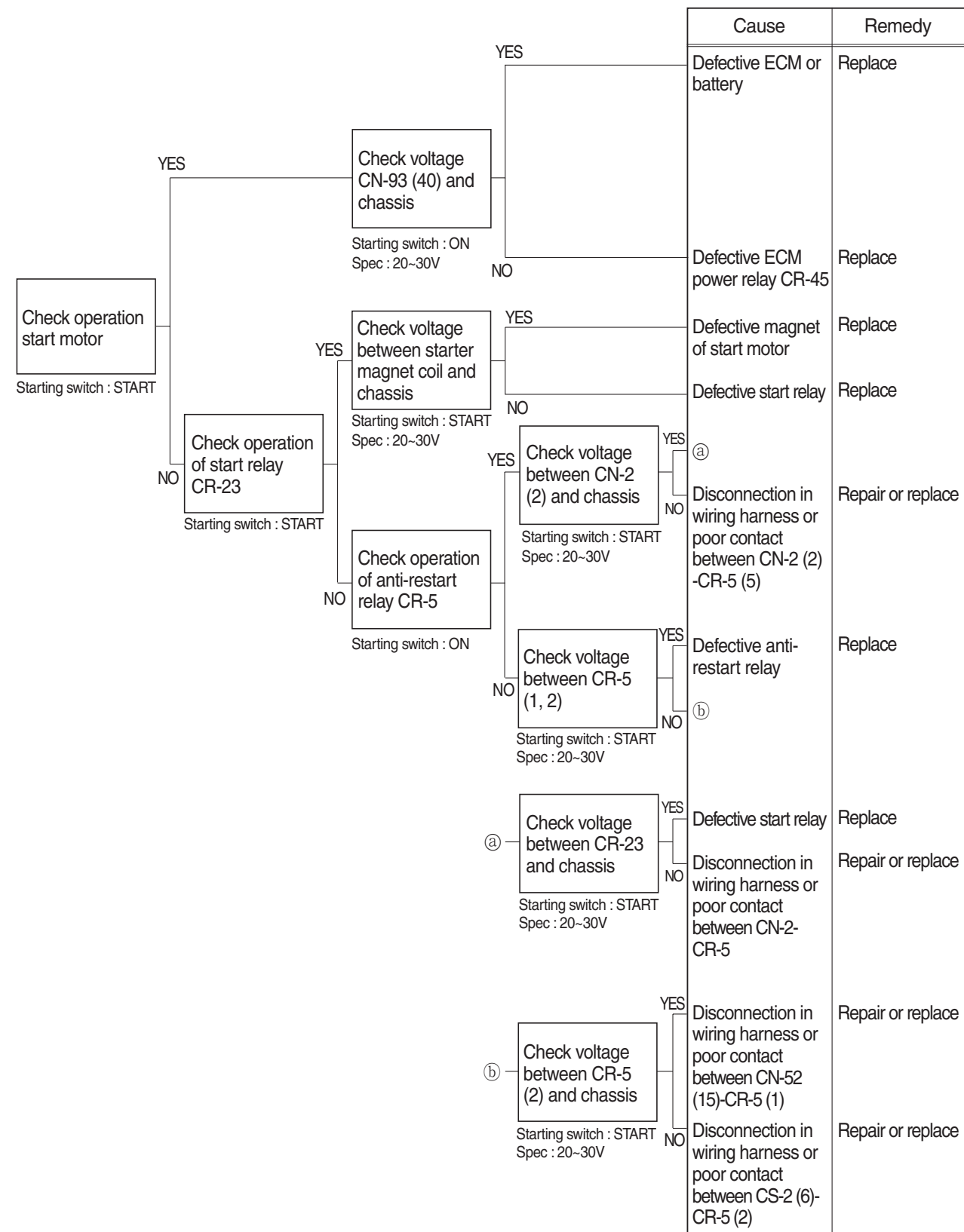

13. WHEN STARTING SWITCH ON DOES NOT OPERATE

- Before disconnecting the connector, always turn the starting switch OFF.
- Before carrying out below procedure, check all the related connectors are properly inserted, master switch ON and check open circuit of fusible link (CN-60).
- After checking, insert the disconnected connectors again immediately unless otherwise specified.

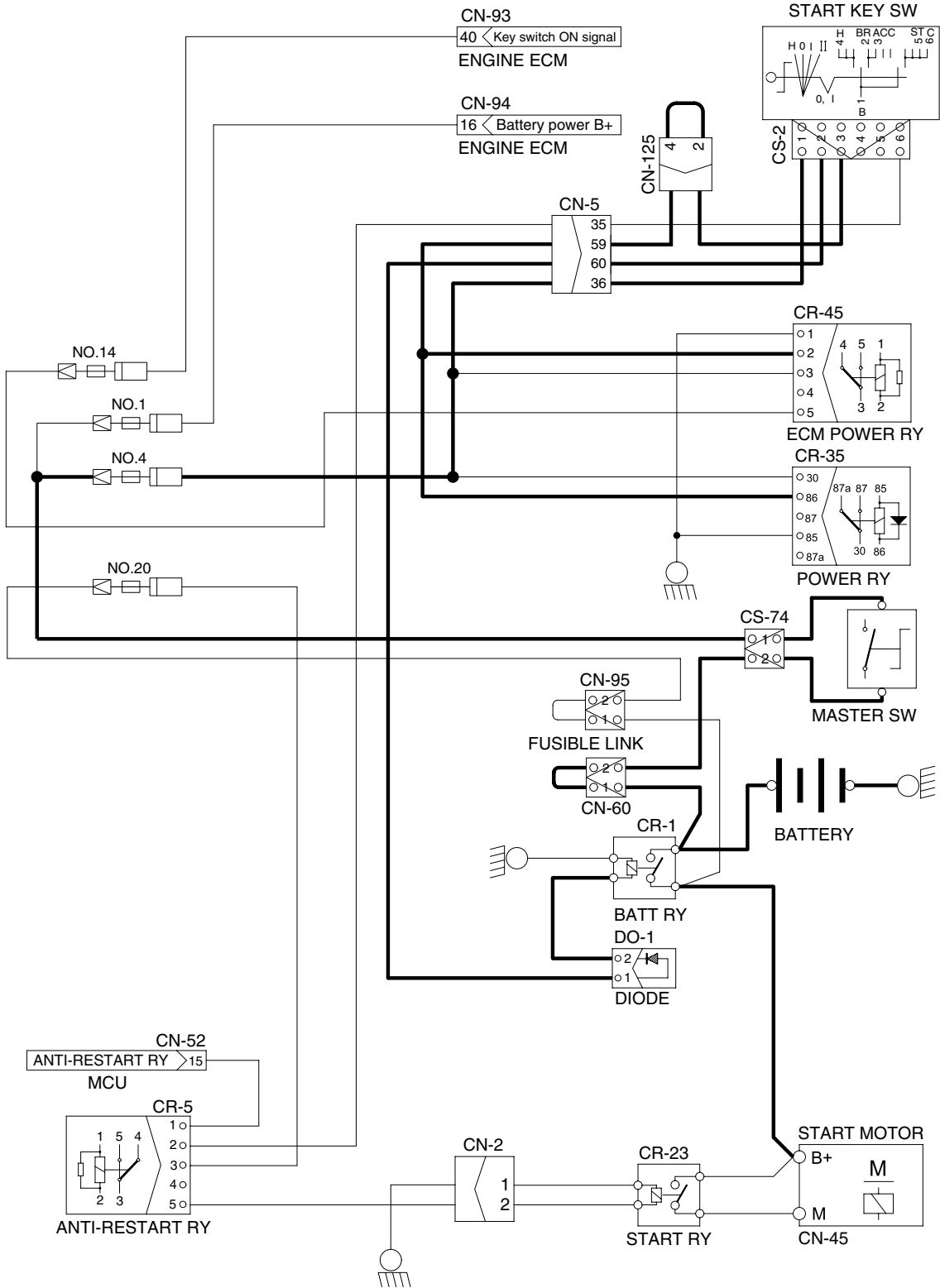
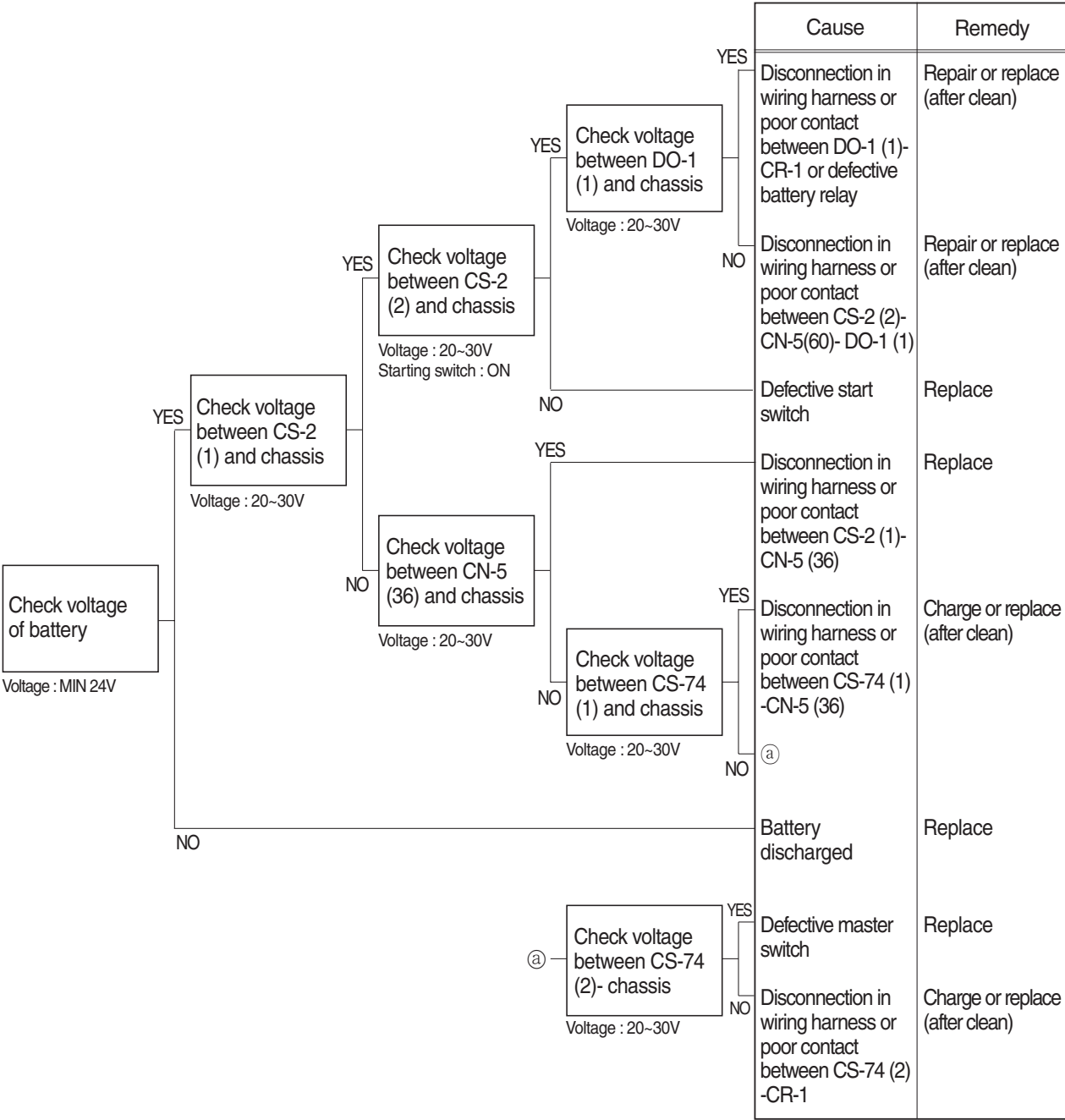

14. WHEN STARTING SWITCH IS TURNED ON, WIPER MOTOR DOES NOT OPERATE

- Before disconnecting the connector, always turn the starting switch OFF.
- Before carrying out below procedure, check all the related connectors are properly inserted and fuse No. 6, 11 and 17 burnt out.
- After checking, insert the disconnected connectors again immediately unless otherwise specified.

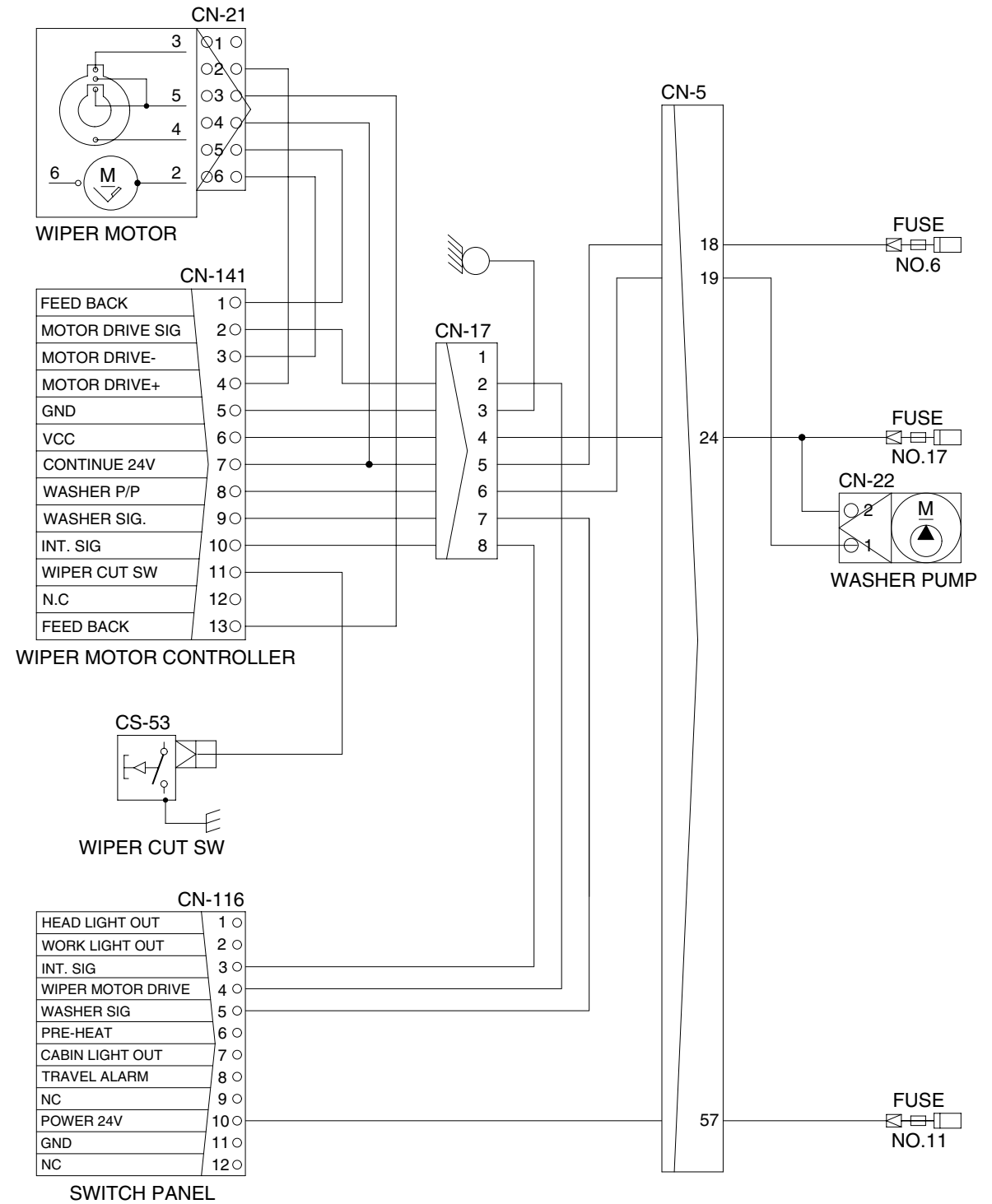
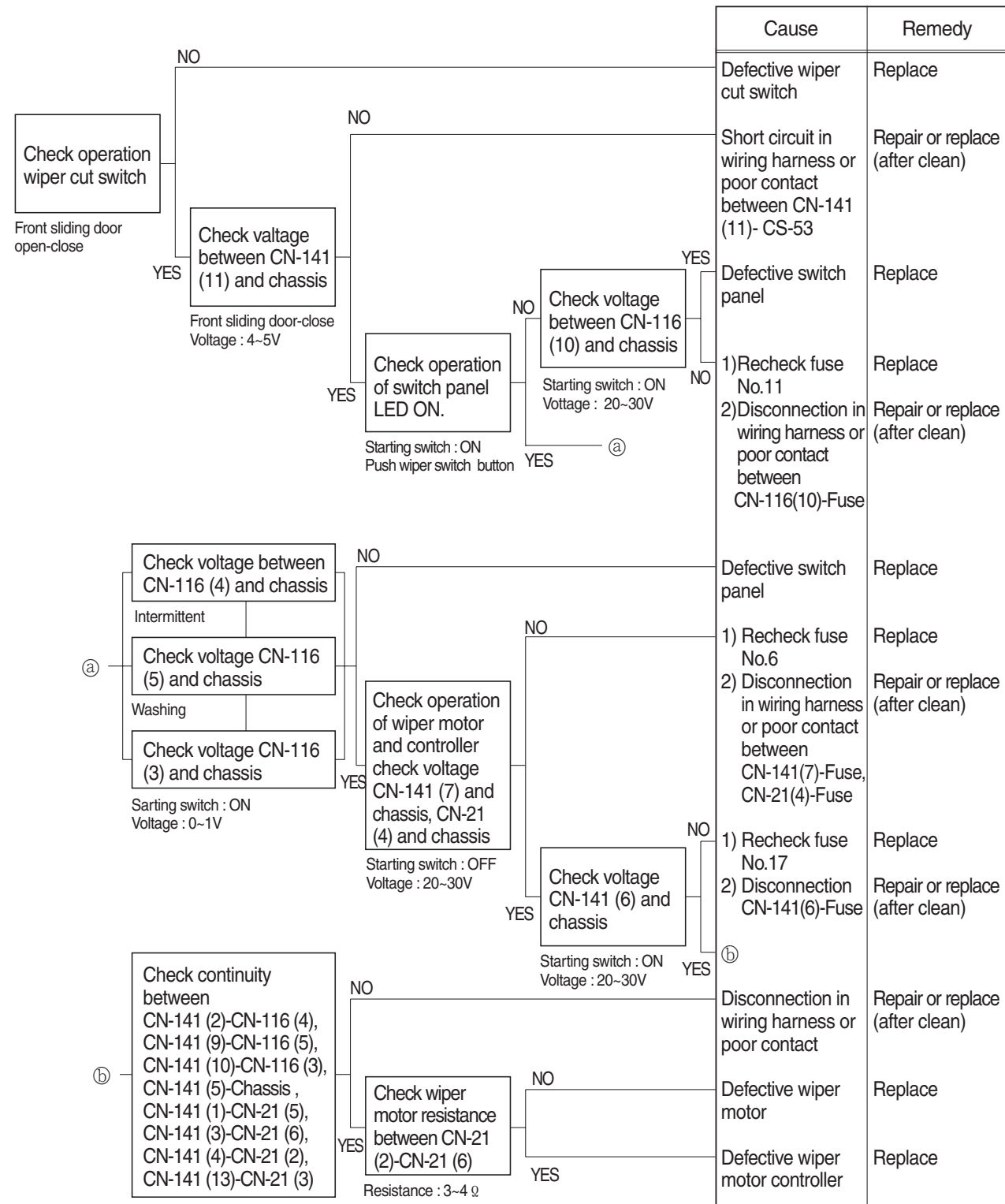

15. WHEN STARTING SWITCH IS TURNED ON, HEAD LAMP DOES NOT LIGHTS UP

- Before disconnecting the connector, always turn the starting switch OFF.
- Before carrying out below procedure, check all the related connectors are properly inserted and fuse No.18 burnt out.
- After checking, insert the disconnected connectors again immediately unless otherwise specified.

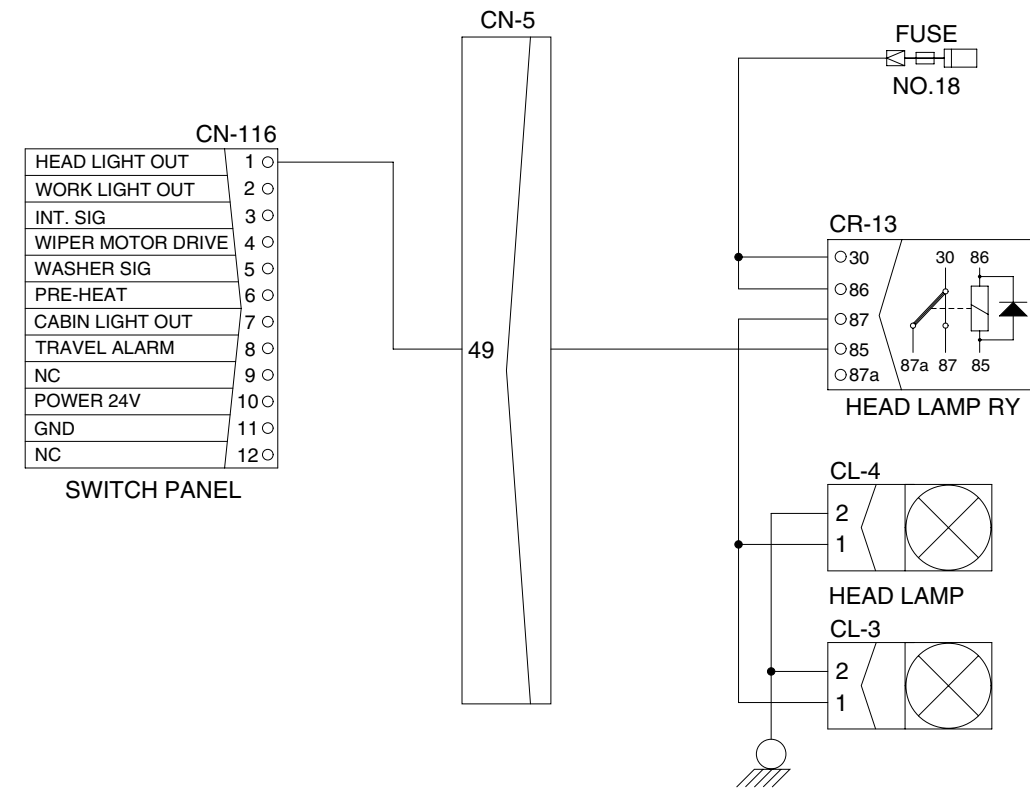
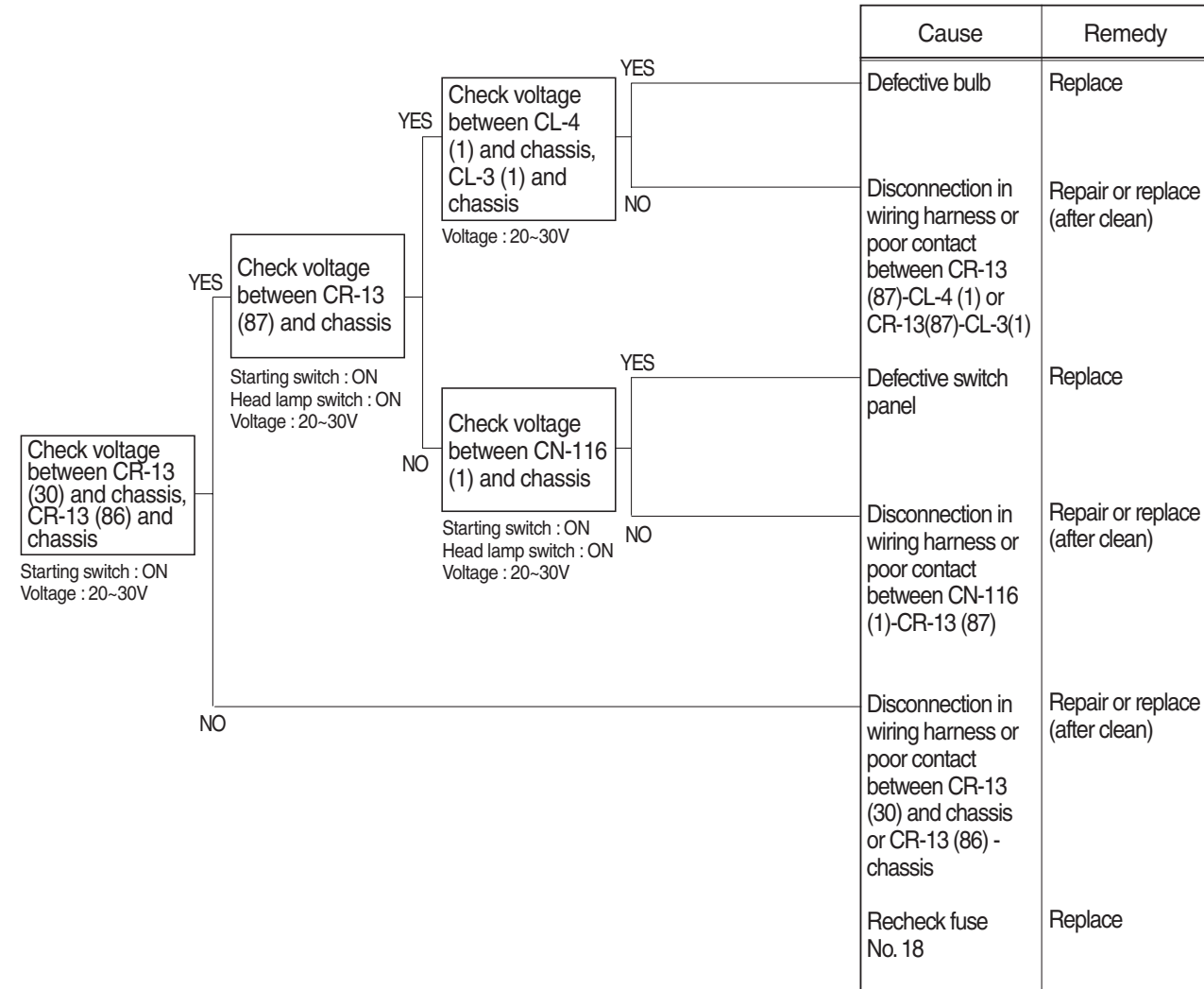

16. WHEN STARTING SWITCH IS TURNED ON, WORK LAMP DOES NOT LIGHTS UP

- Before disconnecting the connector, always turn the starting switch OFF.
- Before carrying out below procedure, check all the related connectors are properly inserted and fuse No.15 burnt out.
- After checking, insert the disconnected connectors again immediately unless otherwise specified.

