

GROUP 3 SWING DEVICE

1. STRUCTURE

Swing device consists swing motor, swing reduction gear.

Swing motor include mechanical parking valve, relief valve, make up valve and time delay valve.

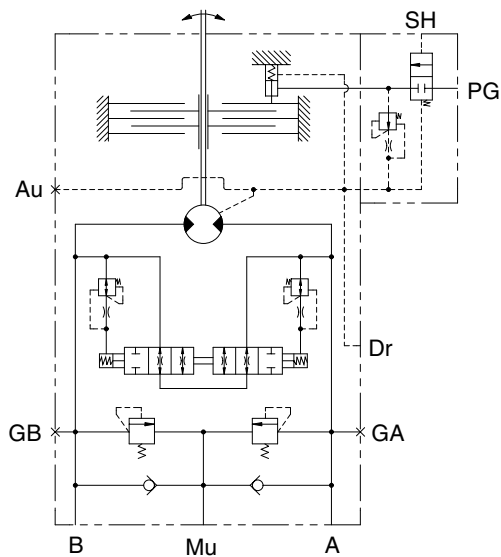
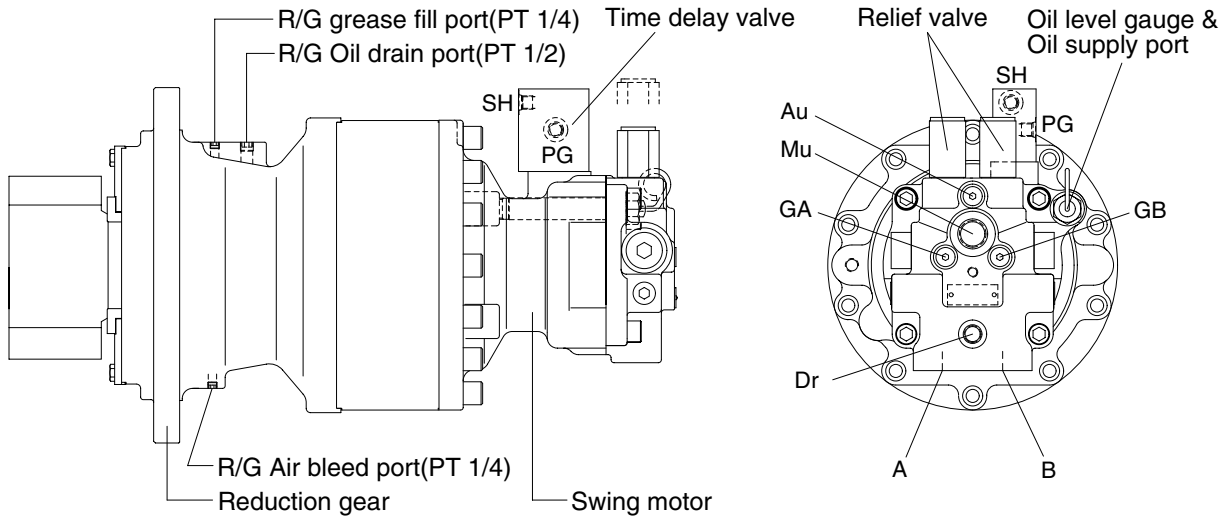

Hydraulic circuit

14W92SM01

Port	Port name	Port size
A	Main port	ø 13
B	Main port	ø 13
Dr	Drain port	PF 3/8
Mu	Make up port	PF 3/4
SH	Brake release port	PF 1/4
PG	Stand by port	PF 1/4
GA, GB	Gage port	PF 1/4
Au	Air vent port	PF 1/4

1) SWING MOTOR

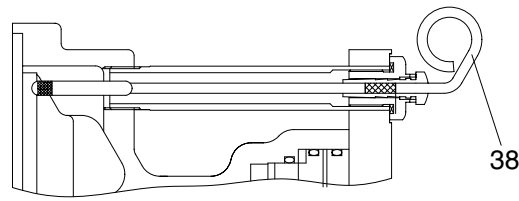

DETAIL K

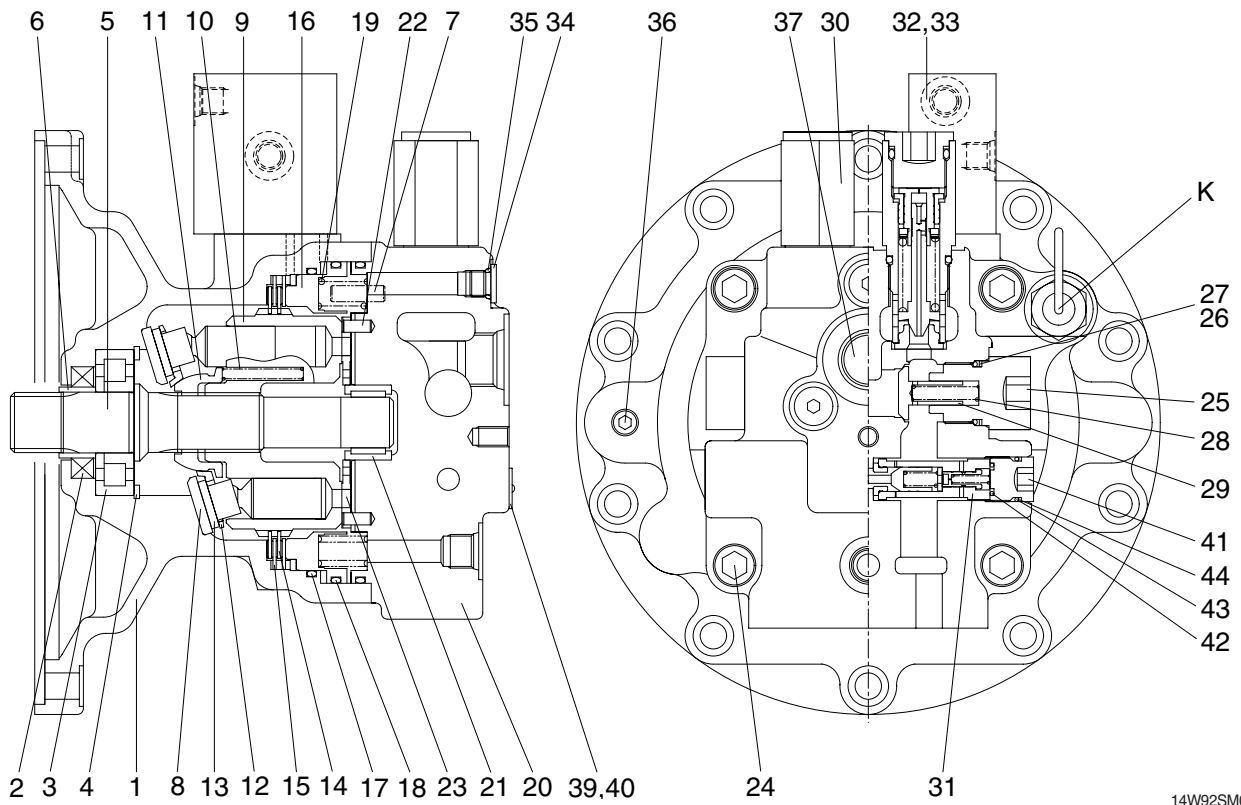

14W92SM02

- | | | | | | |
|----|-----------------|----|----------------|----|---------------------|
| 1 | Body | 16 | Brake piston | 31 | Anti-rotating valve |
| 2 | Oil seal | 17 | O-ring | 32 | Time delay valve |
| 3 | Roller bearing | 18 | O-ring | 33 | Wrench bolt |
| 4 | Snap ring | 19 | Brake spring | 34 | Plug |
| 5 | Drive shaft | 20 | Rear cover | 35 | O-ring |
| 6 | Bushing | 21 | Needle bearing | 36 | Plug |
| 7 | Pin | 22 | Pin | 37 | Plug |
| 8 | Shoe plate | 23 | Valve plate | 38 | Level gauge |
| 9 | Cylinder block | 24 | Wrench bolt | 40 | Rivet |
| 10 | Spring | 25 | Plug | 41 | Plug |
| 11 | Ball guide | 26 | Back up ring | 42 | O-ring |
| 12 | Set plate | 27 | O-ring | 43 | O-ring |
| 13 | Piston assembly | 28 | Spring | 44 | Back up ring |
| 14 | Friction plate | 29 | Check | | |
| 15 | Separate plate | 30 | Relief valve | | |

2) REDUCTION GEAR

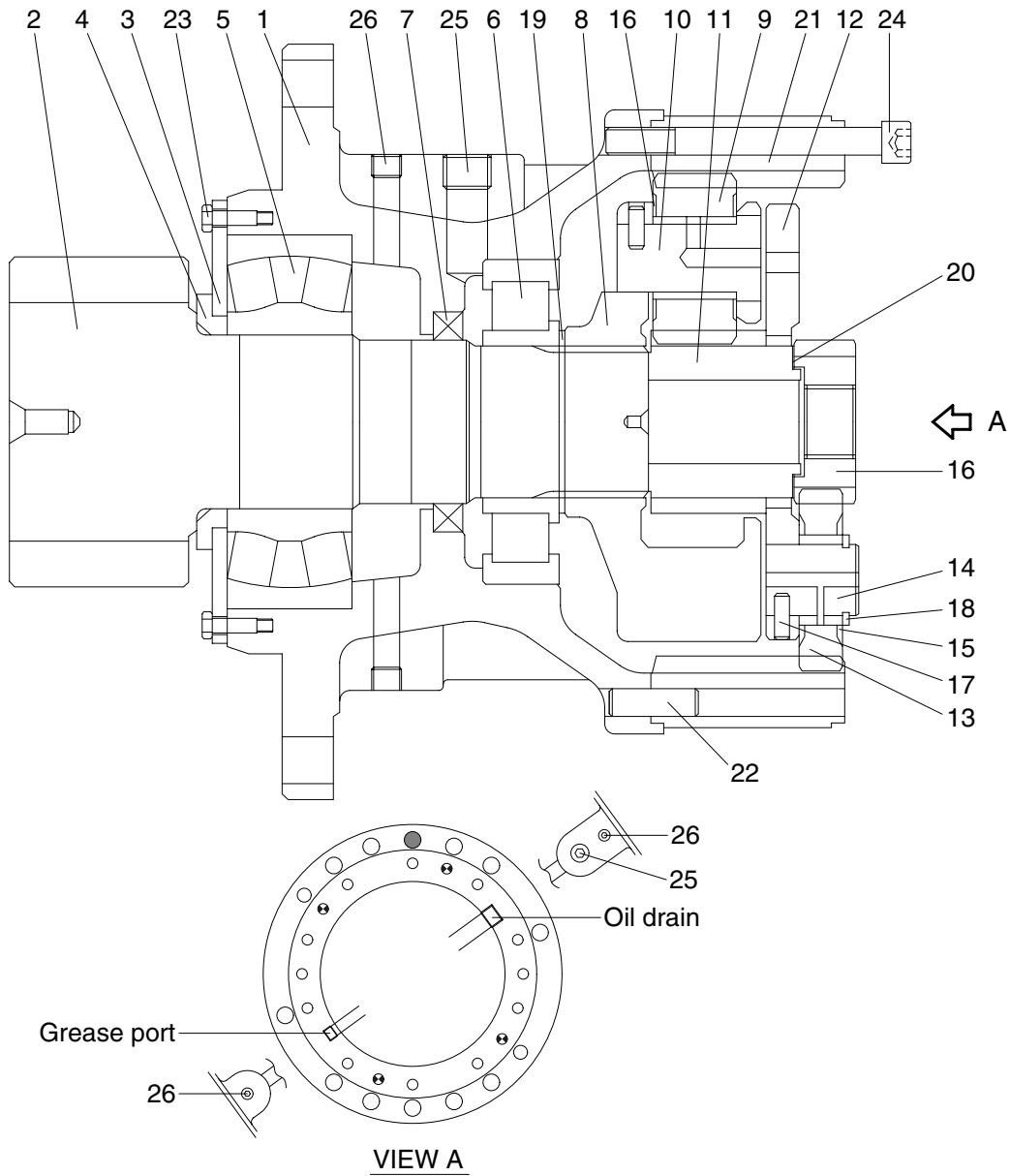

1	Casing	10	Pin No.2 assembly	19	Stop ring
2	Drive shaft	11	Sun gear No. 2	20	Side plate No. 1
3	Cover plate	12	Carrier No. 1	21	Ring gear
4	Spacer	13	Planet gear No. 1	22	Knock pin
5	Roller bearing	14	Pin No.1	23	Hexagonal bolt
6	Roller bearing	15	Thrust washer (B)	24	Socket head bolt
7	Oil seal	16	Sun gear No. 1	25	Plug
8	Carrier No. 2	17	Spring pin	26	Plug
9	Planet gear No. 2	18	Stop ring		

14W92SM03

2. PRINCIPLE OF DRIVING

1) GENERATING THE TURNING FORCE

The high hydraulic supplied from a hydraulic pump flows into a cylinder (9) through valve cover of motor (20), and valve plate (23).

The high hydraulic is built as flowing on one side of Y-Y line connected by the upper and lower sides of piston (13).

The high hydraulic can generate the force, $F1=P \times A$ (P : supplied pressure, A : water pressure area), like following pictures, working on a piston.

This force, $F1$, is divided as $N1$ thrust partial pressure and $W1$ radial partial pressure, in case of the plate of a tilt angle, α .

$W1$ generates torque, $T=W1 \times R1$, for Y-Y line connected by the upper and lower sides of the piston as following pictures.

The sum of torque ($\Sigma W1 \times R1$), generated from each piston (4~5 pieces) on the side of a high hydraulic, generates the turning force.

This torque transfers the turning force to a cylinder (9) through a piston; because a cylinder is combined with a turning axis and spline, a turning axis rotates and a turning force is sent.

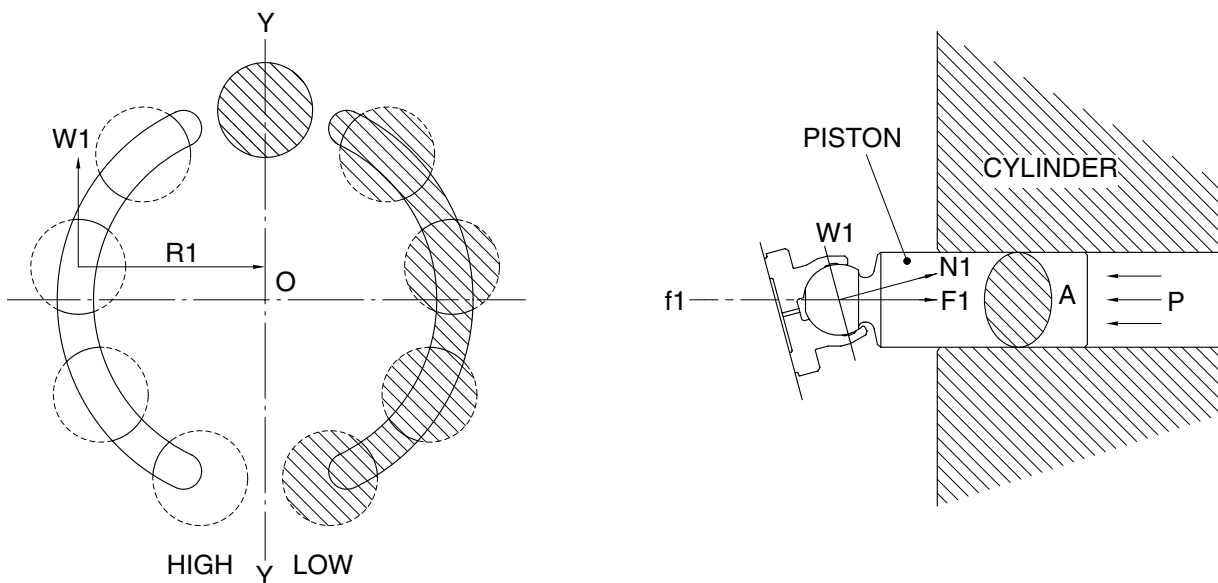

14072NEWSM03

2) MAKE UP VALVE

In the system using this type of motor, there is no counter balance functioning valve and there happens the case of revolution exceeding hydraulic supply of motor. To prevent the cavitation caused by insufficient oil flow there is a make up valve to fill up the oil insufficiency.

A make up valve is provided immediately before the port leading to the hydraulic oil tank to secure feed pressure required when the hydraulic motor makes a pumping action. The boost pressure acts on the hydraulic motor's feed port via the make up valve.

Pressurized oil into the port B, the motor rotate counterclockwise.

If the plunger of MCV moves neutral position, the oil in the motor is drain via left relief valve, the drain oil run into motor via right make up valve, which prevent the cavitation of motor.

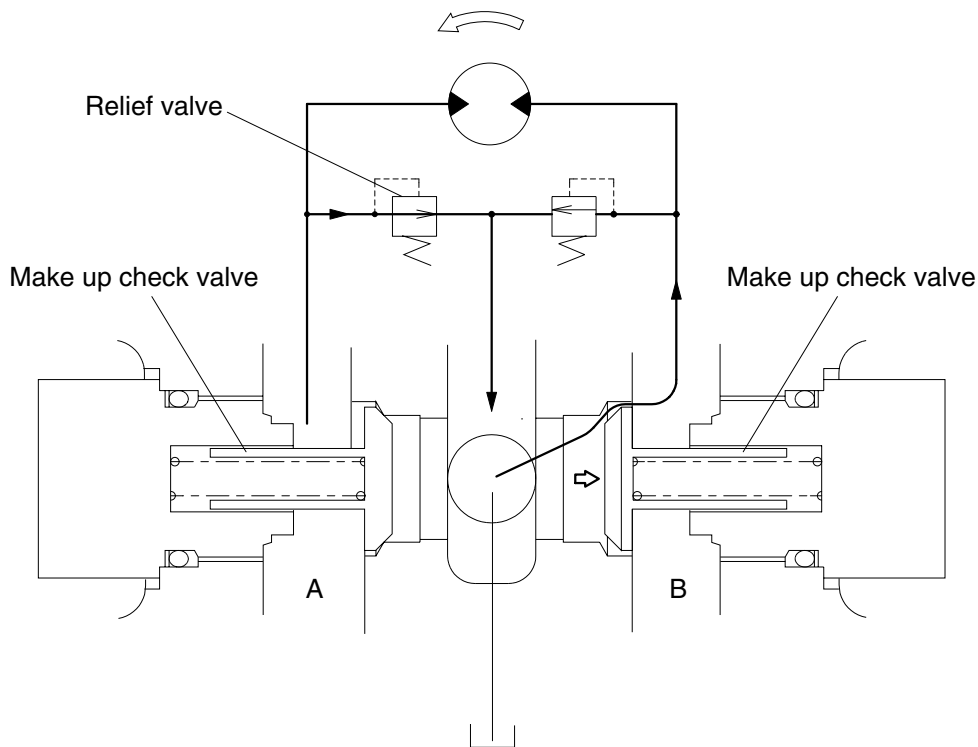

21092SM04

3) RELIEF VALVE

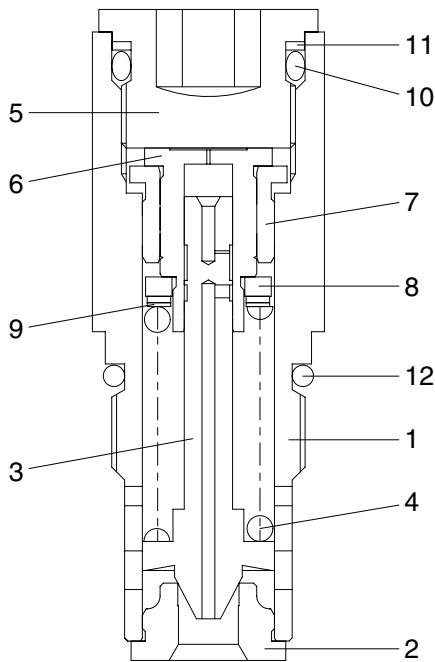

- 1 Body
- 2 Seat
- 3 Plunger
- 4 Spring
- 5 Adjusting screw
- 6 Piston
- 7 Bushing
- 8 Spring seat
- 9 Shim
- 10 O-ring
- 11 Back up ring
- 12 O-ring

14007A2SM05

(1) Construction of relief valve

The valve casing contains two cartridge type relief valves that stop the regular and reverse rotations of the hydraulic motor. The relief valves relieve high pressure at start or at stop of swing motion and can control the relief pressure in two steps, high and low, in order to insure smooth operation.

(2) Function of relief valve

Figure illustrates how the pressure acting on the relief valve is related to its rising process. Here is given the function, referring to the figure following page.

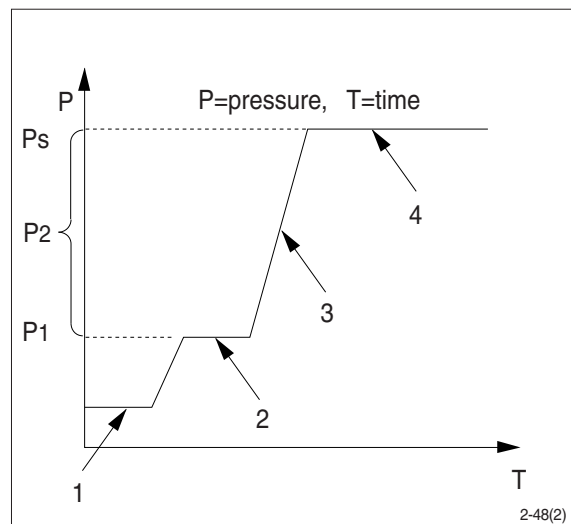

2-48(2)

① Ports (P,R) at tank pressure.

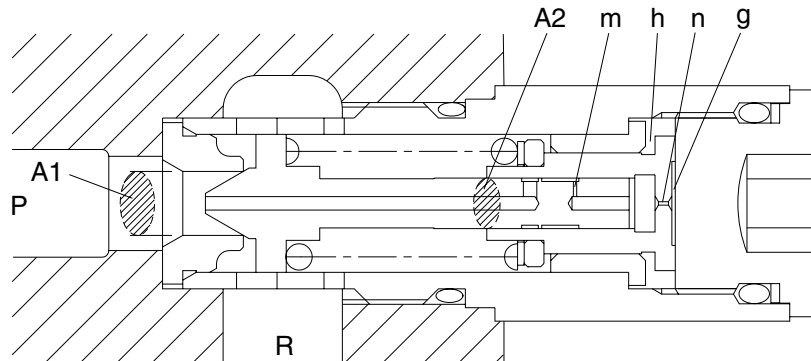

14007A2SM06

② When hydraulic oil pressure ($P \times A_1$) reaches the preset force (F_{SP}) of spring (4), the plunger (3) moves to the right as shown.

$$P_1 \times A_1 = F_{SP} + P_g \times A_2$$

$$P_1 = \frac{F_{SP} + P_g \times A_2}{A_1}$$

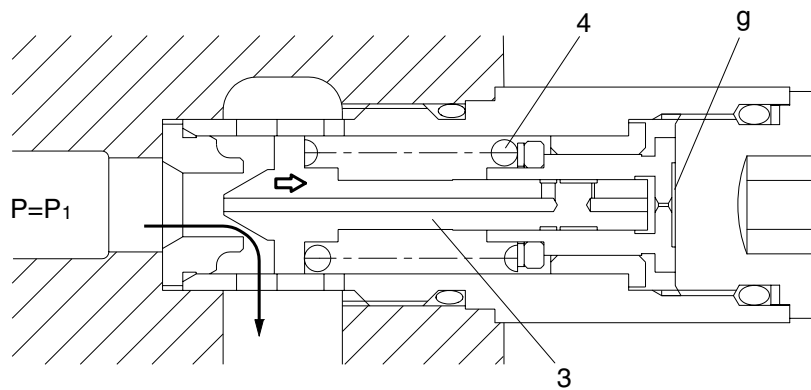

14007A2SM07

- ③ The oil flow chamber g via orifice m and n. When the pressure of chamber g reaches the preset force (F_{SP}) of spring (4), the piston (6) moves left and stop the piston (6) hits the bottom of bushing (7).

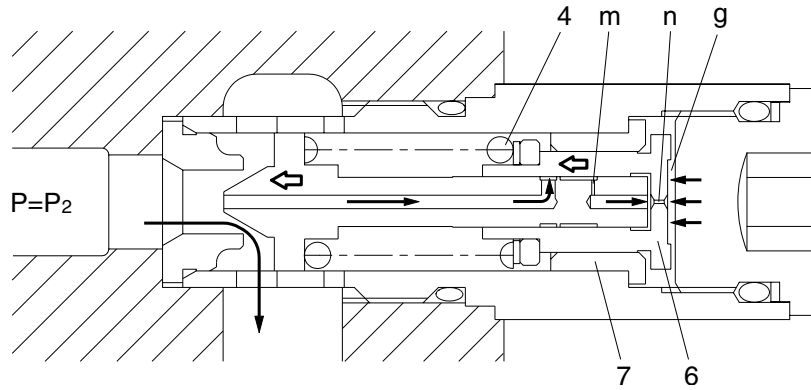

14007A2SM08

- ④ When piston (6) hits the bottom of bushing (7), it stops moving to the left any further. As the result, the pressure in chamber (g) equals (P_s).

$$P_s \times A_1 = F_{sp} + P_s \times A_2$$

$$P_s = \frac{F_{sp}}{A_1 - A_2}$$

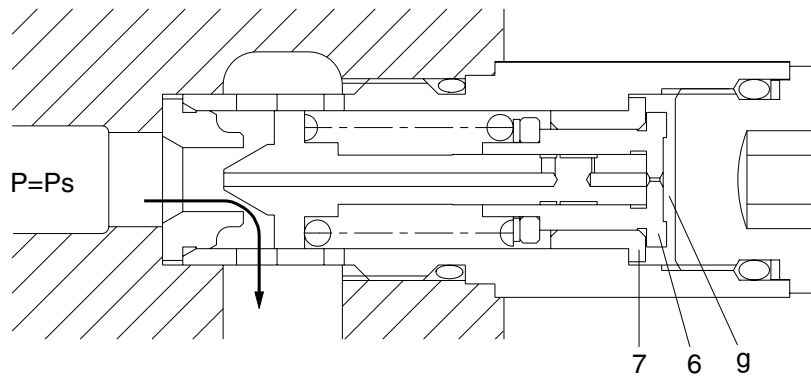

14007A2SM09

4) ANTI-INVERSION VALVE

In the event of swing motor operates switch part to drive and stop the swing part. By the action of pump on motor, there is brake on both-side of port because of the block on both sides.

Swing part is stopped by pressure of brake (in order words, 4-5 times of inversion)

Under the operating condition, the side of anti-inversion blocks off both ports but bypassing compressed oil which is blocked in processing of anti-inversion fixed time and amount to inverse port, prevent increasing pressure of motor and decrease inversing action.

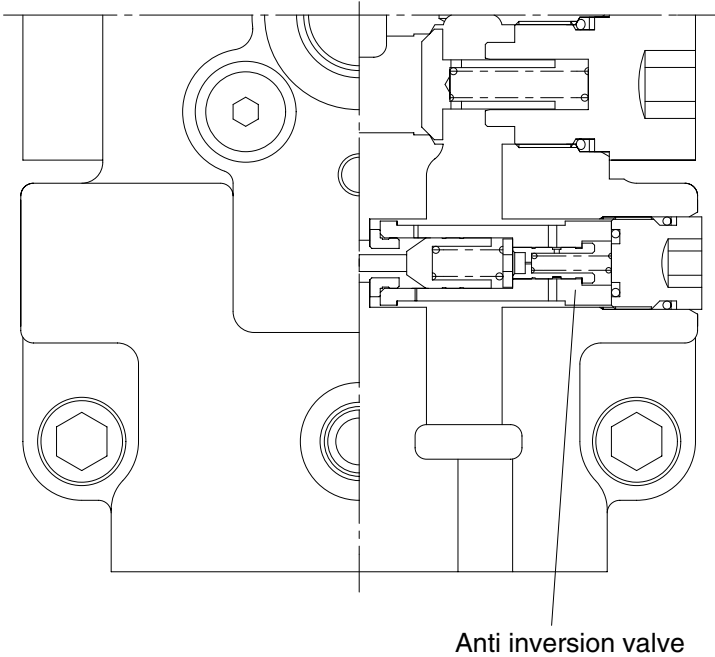

14W92SM10

5) BRAKE SYSTEM

(1) Control valve swing brake system

This is the brake system to stop the swing motion of the excavator during operation.

In this system, the hydraulic circuit is throttled by the swing control valve, and the resistance created by this throttling works as a brake force to slow down the swing motion.

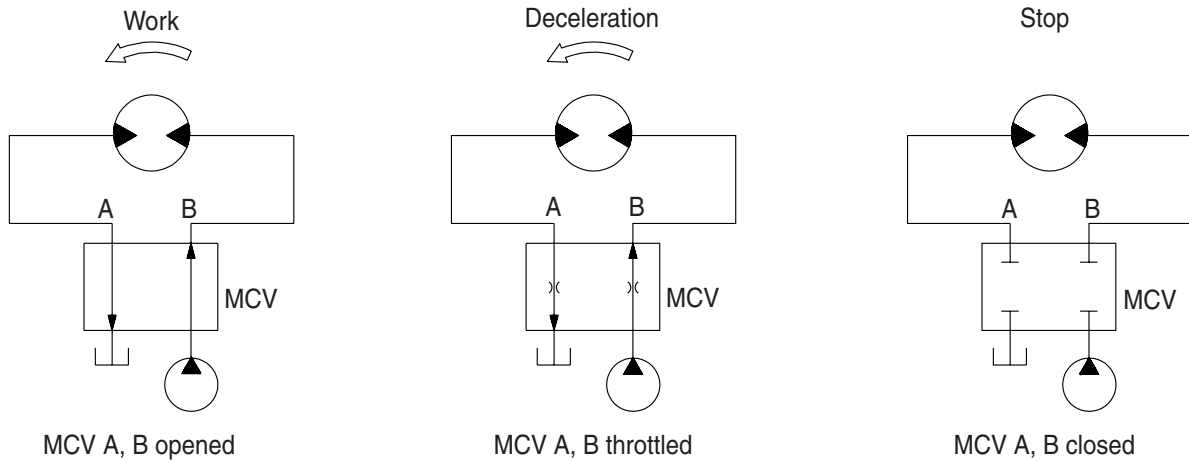

2-48(1)

(2) Mechanical swing parking brake system

This is function as a parking brake only when all of the RCV lever (except travel pedal) are not operated.

① Brake assembly

Circumferential rotation of separate plate (15) is constrained by the groove located at housing (1). When housing is pressed down by brake spring (19) through friction plate (14), separate plate (15) and brake piston (16), friction force occurs there.

Cylinder block (9) is constrained by this friction force and brake acts, while brake releases when hydraulic force exceeds spring force.

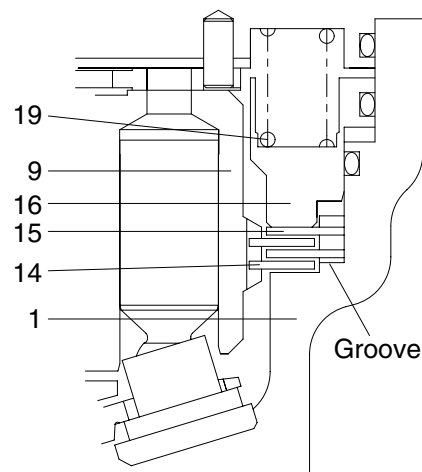

14W92SM15

1	Housing	15	Separate plate
9	Cylinder block	16	Brake piston
14	Friction plate	19	Spring

② **Operating principle**

- a. When one of the RCV lever (1) is set to the operation position, the each spool is shifted to left or right and the pilot oil flow is blocked. Then the pilot oil go to SH of the time delay valve (3). This pressure moves spool (5) to the leftward against the force of the spring(8), so pilot pump charged oil (P3) goes to the chamber G through port PG. This pressure is applied to move the piston (16) to the upward against the force of the spring (19). Thus, it releases the brake force.

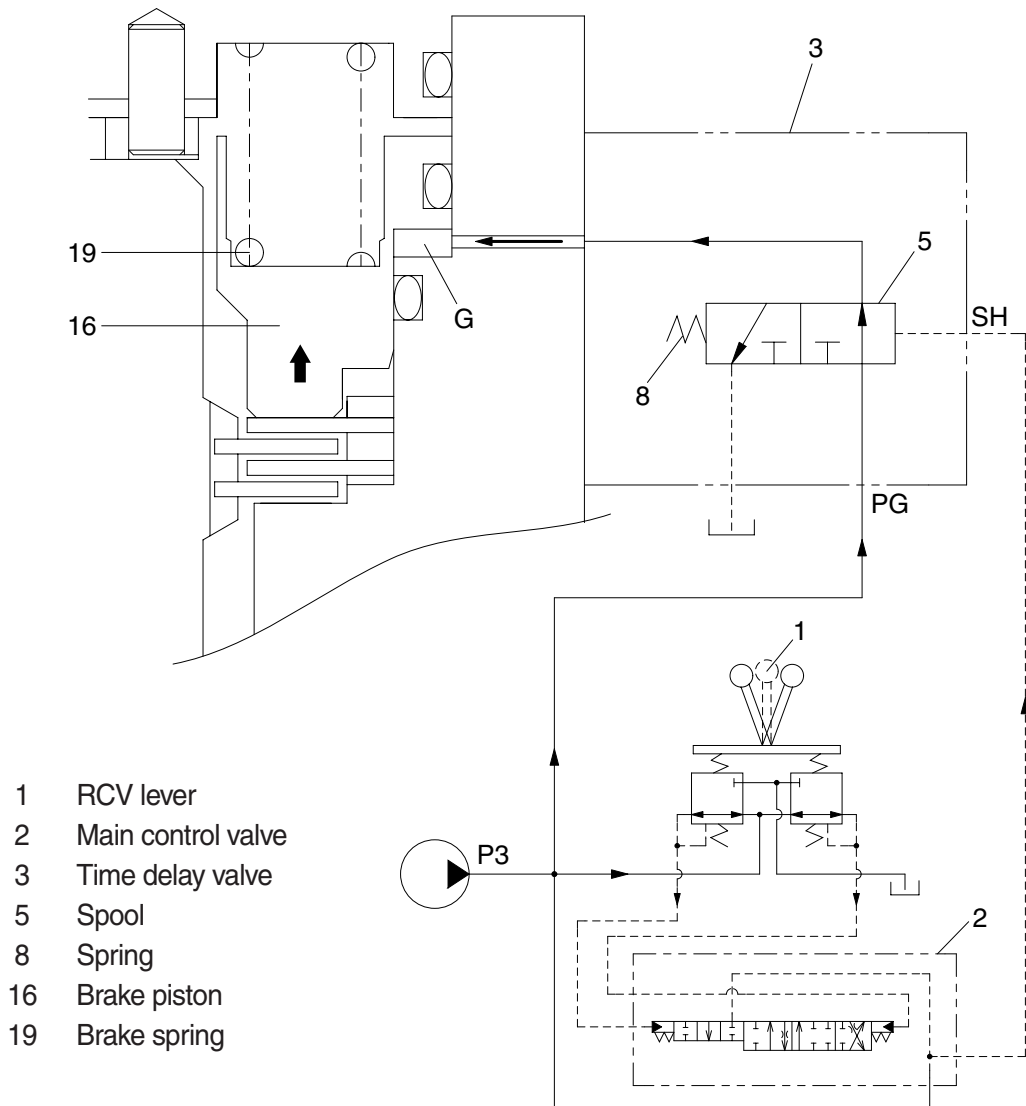

14W92SM16

- b. When all of the RCV lever (1) are set the neutral position, the spool (5) returns to right. Then, the piston (16) is moved lower by spring force and the return oil from the chamber G flows back to tank port. At this time, the brake works.

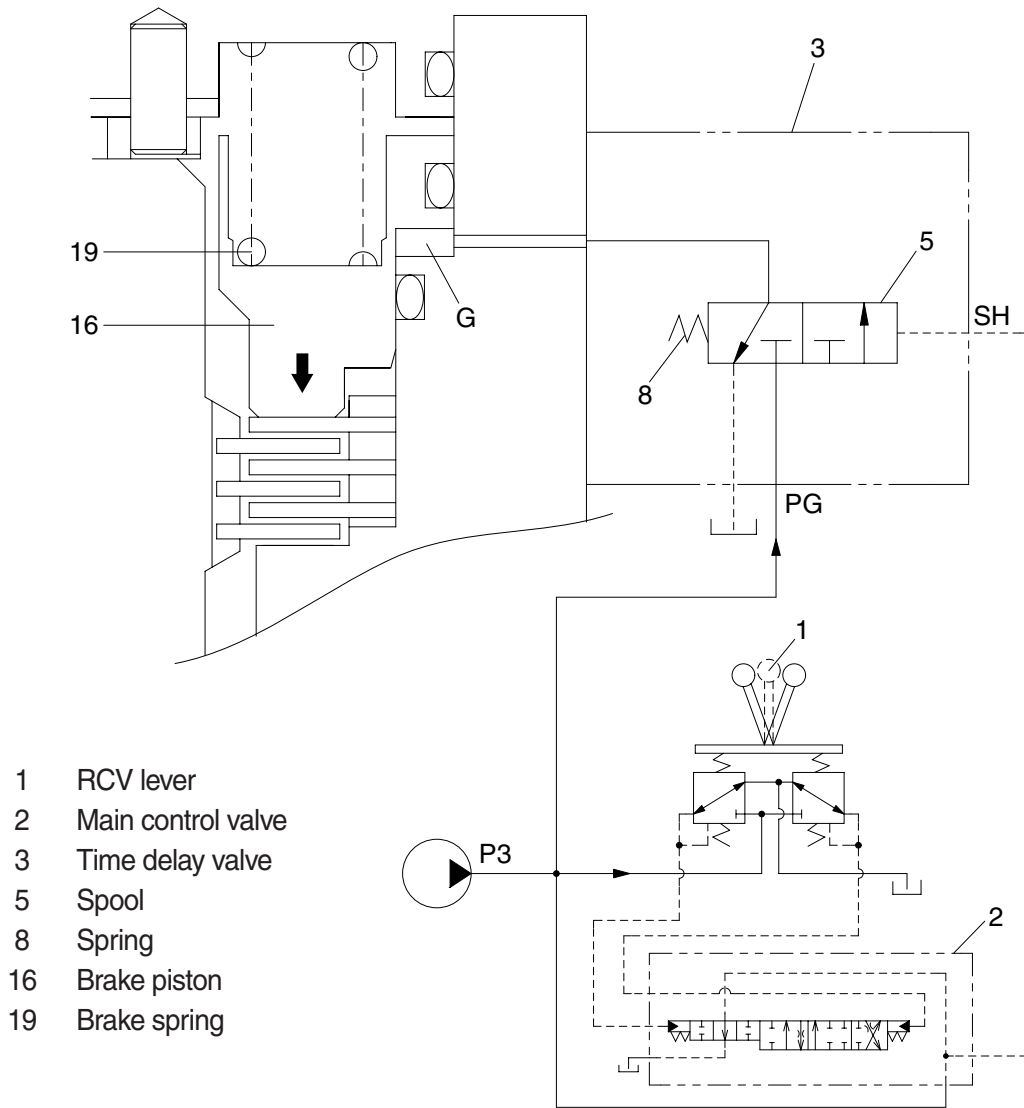

14W92SM17