

## SECTION 9 COMPONENT MOUNTING TORQUE

Group 1	Introduction guide	9-1
Group 2	Engine system	9-2
Group 3	Electric system	9-4
Group 4	Hydraulic system	9-6
Group 5	Undercarriage	9-10
Group 6	Structure	9-11
Group 7	Work equipment	9-14

# SECTION 9 COMPONENT MOUNTING TORQUE

## GROUP 1 INTRODUCTION GUIDE

1. This section shows bolt specifications and standard torque values needed when mounting components to the machine.
2. Use genuine Hyundai spare parts.  
We expressly point out that Hyundai will not accept any responsibility for defects resulted from non-genuine parts.  
In such cases Hyundai cannot assume liability for any damage.

**Only metric fasteners can be used and incorrect fasteners may result in machine damage or malfunction.**

**Before installation, clean all the components with a non-corrosive cleaner. Bolts and threads must not be worn or damaged.**

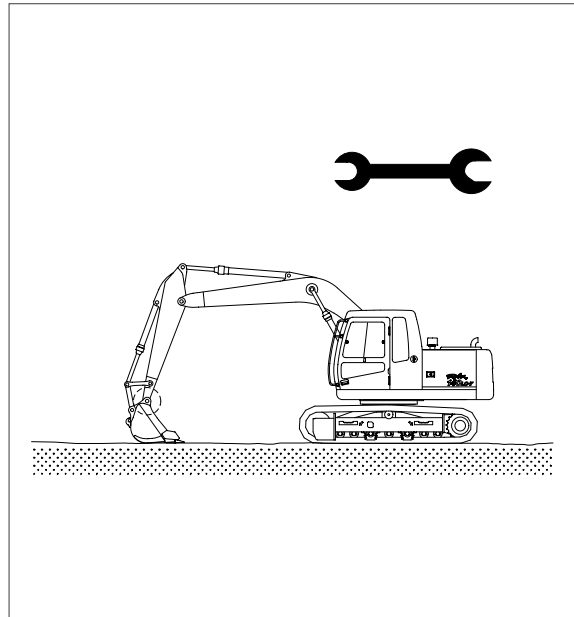

## GROUP 2 ENGINE SYSTEM

### 1. ENGINE AND ACCESSORIES MOUNTING

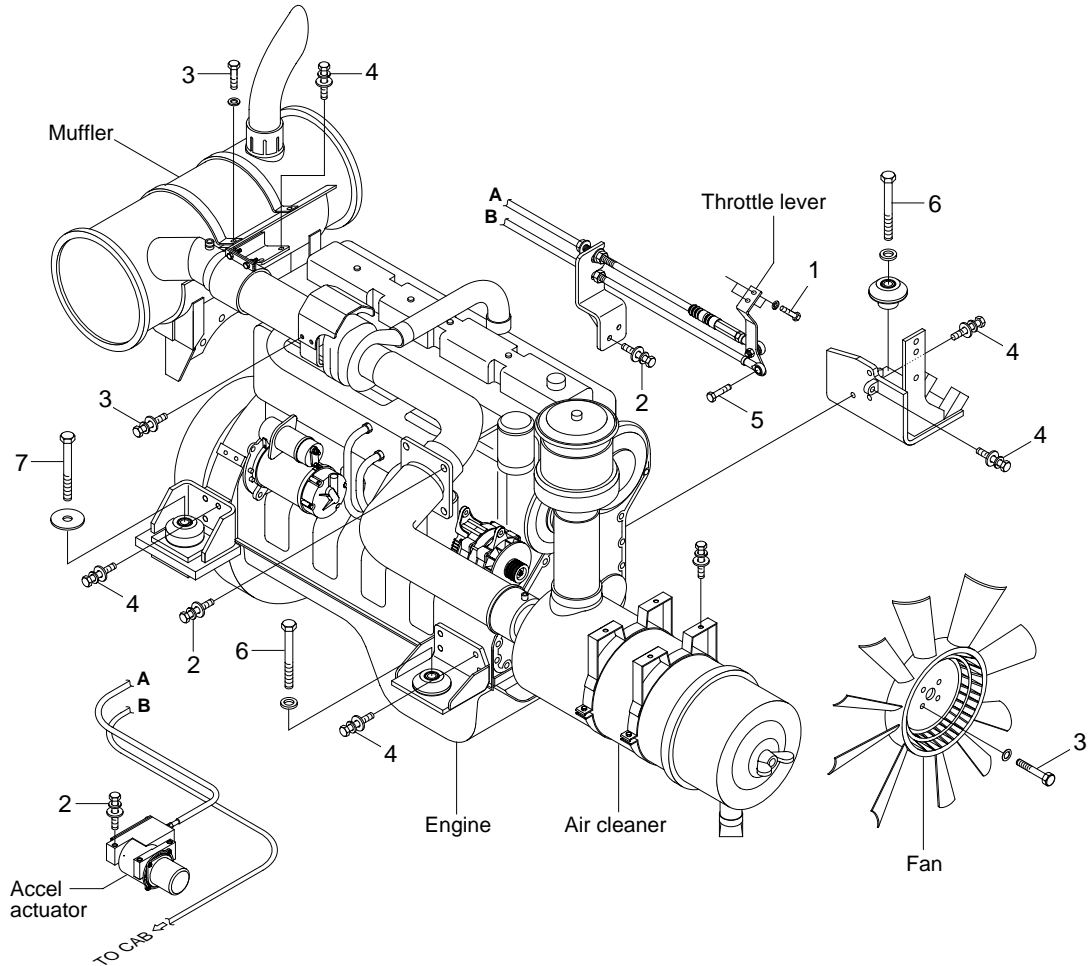

· Tightening torque

Item	Size	kgf · m	lbf · ft
1	M 6 × 1.0	0.92 ± 0.2	6.7 ± 1.4
2	M 8 × 1.25	2.5 ± 0.5	18.1 ± 3.6
3	M10 × 1.5	4.7 ± 0.9	34.0 ± 6.5
4	M12 × 1.75	10 ± 20	72.3 ± 14.5

Item	Size	kgf · m	lbf · ft
5	M 6 × 1.0	1.05 ± 0.2	7.6 ± 1.45
6	M16 × 2.0	30 ± 3.5	217 ± 25.3
7	M20 × 2.5	55 ± 3.5	398 ± 25.3
-	-	-	-

## 2. COOLING SYSTEM AND FUEL TANK MOUNTING

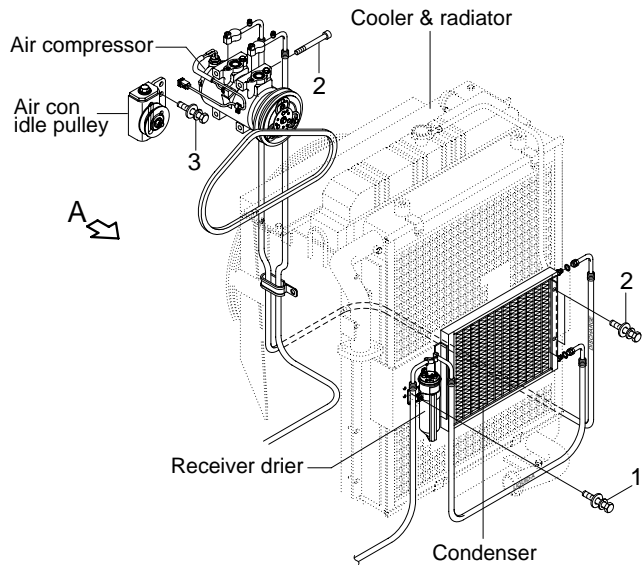
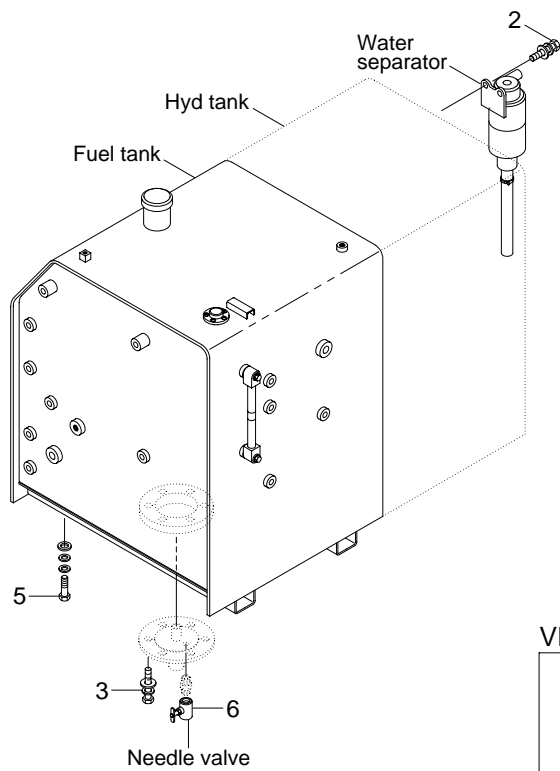

VIEW A

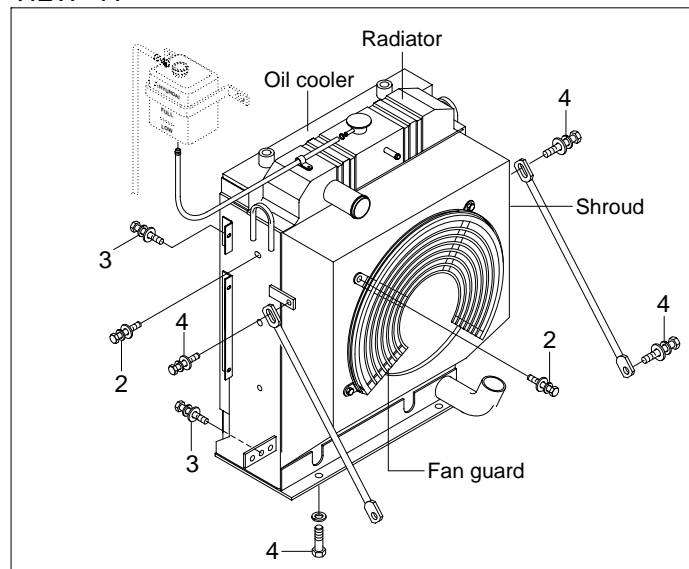

### · Tightening torque

Item	Size	kgf · m	lbf · ft
1	M 6 × 1.0	1.05 ± 0.2	7.6 ± 1.45
2	M 8 × 1.25	2.5 ± 0.5	18.1 ± 3.6
3	M10 × 1.5	6.9 ± 1.4	49.9 ± 10.1

Item	Size	kgf · m	lbf · ft
4	M12 × 1.75	12.8 ± 3.0	92.6 ± 21.7
5	M20 × 2.5	45 ± 5.1	325 ± 36.9
6	-	2.3 ± 0.6	16.6 ± 4.3

# GROUP 3 ELECTRIC SYSTEM

## 1. ELECTRIC COMPONENTS MOUNTING 1

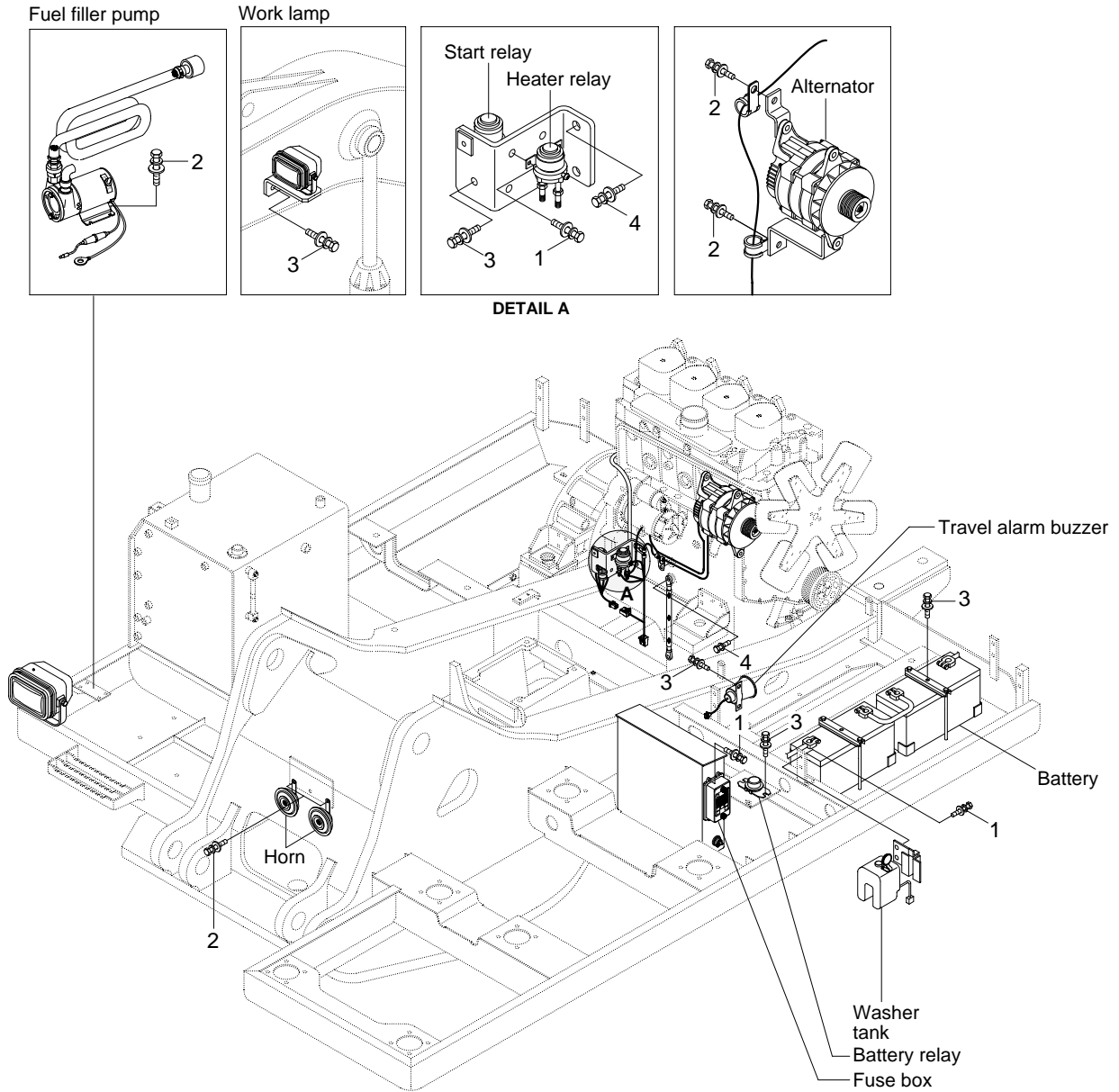

### · Tightening torque

Item	Size	kgf · m	lbf · ft
1	M 6 × 1.0	1.05 ± 0.2	7.6 ± 1.45
2	M 8 × 1.25	2.5 ± 0.5	18.1 ± 3.6

Item	Size	kgf · m	lbf · ft
3	M10 × 1.5	6.9 ± 1.4	49.9 ± 10.1
4	M12 × 1.75	12.8 ± 3.0	92.6 ± 21.7

## 2. ELECTRIC COMPONENTS MOUNTING 2

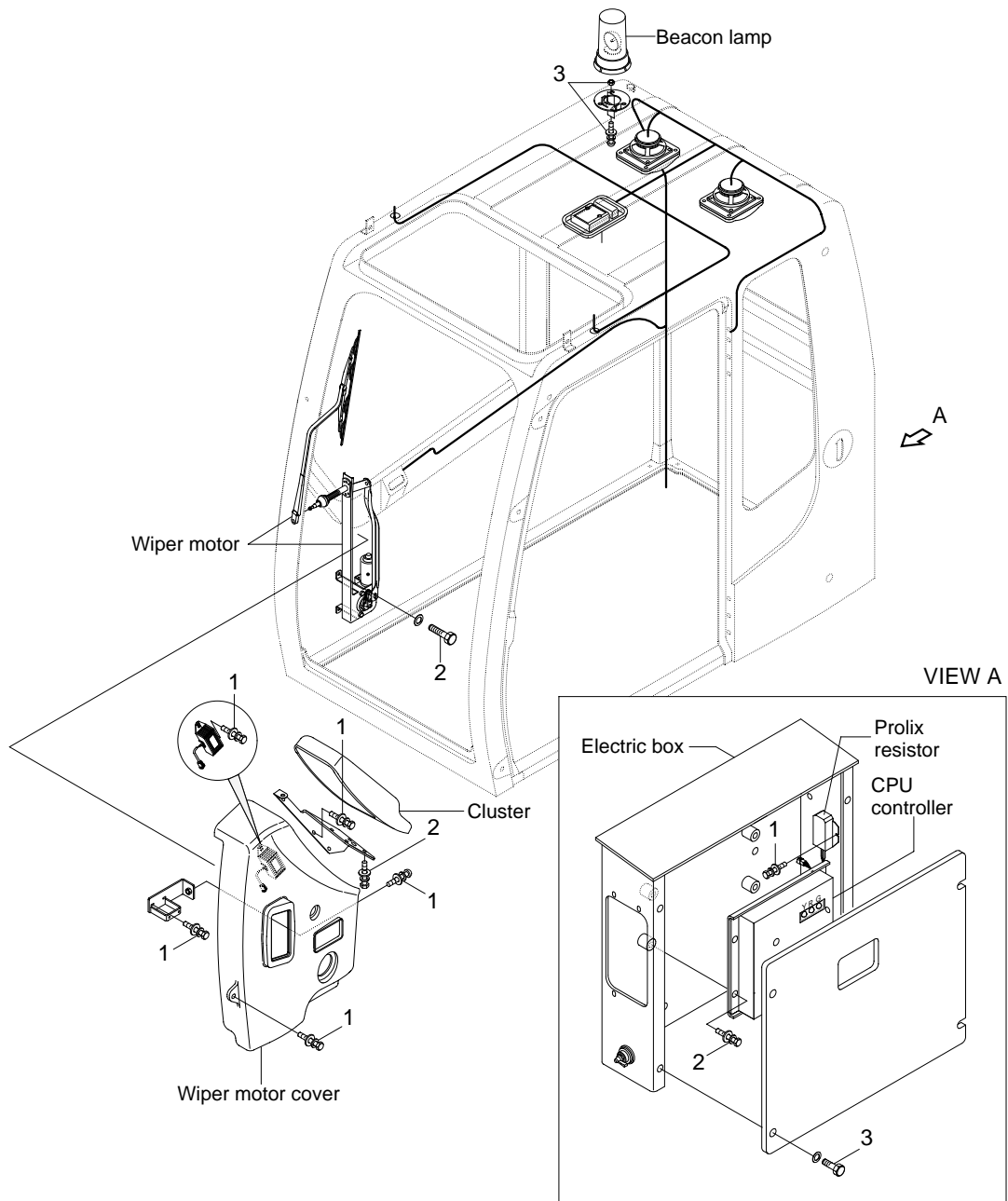

### · Tightening torque

Item	Size	kgf · m	lbf · ft
1	M 6 × 1.0	1.05 ± 0.2	7.6 ± 1.45
2	M 8 × 1.25	2.5 ± 0.5	18.1 ± 3.6

Item	Size	kgf · m	lbf · ft
3	M10 × 1.5	6.9 ± 1.4	49.9 ± 10.1
-	-	-	-

# GROUP 4 HYDRAULIC SYSTEM

## 1. HYDRAULIC COMPONENTS MOUNTING 1

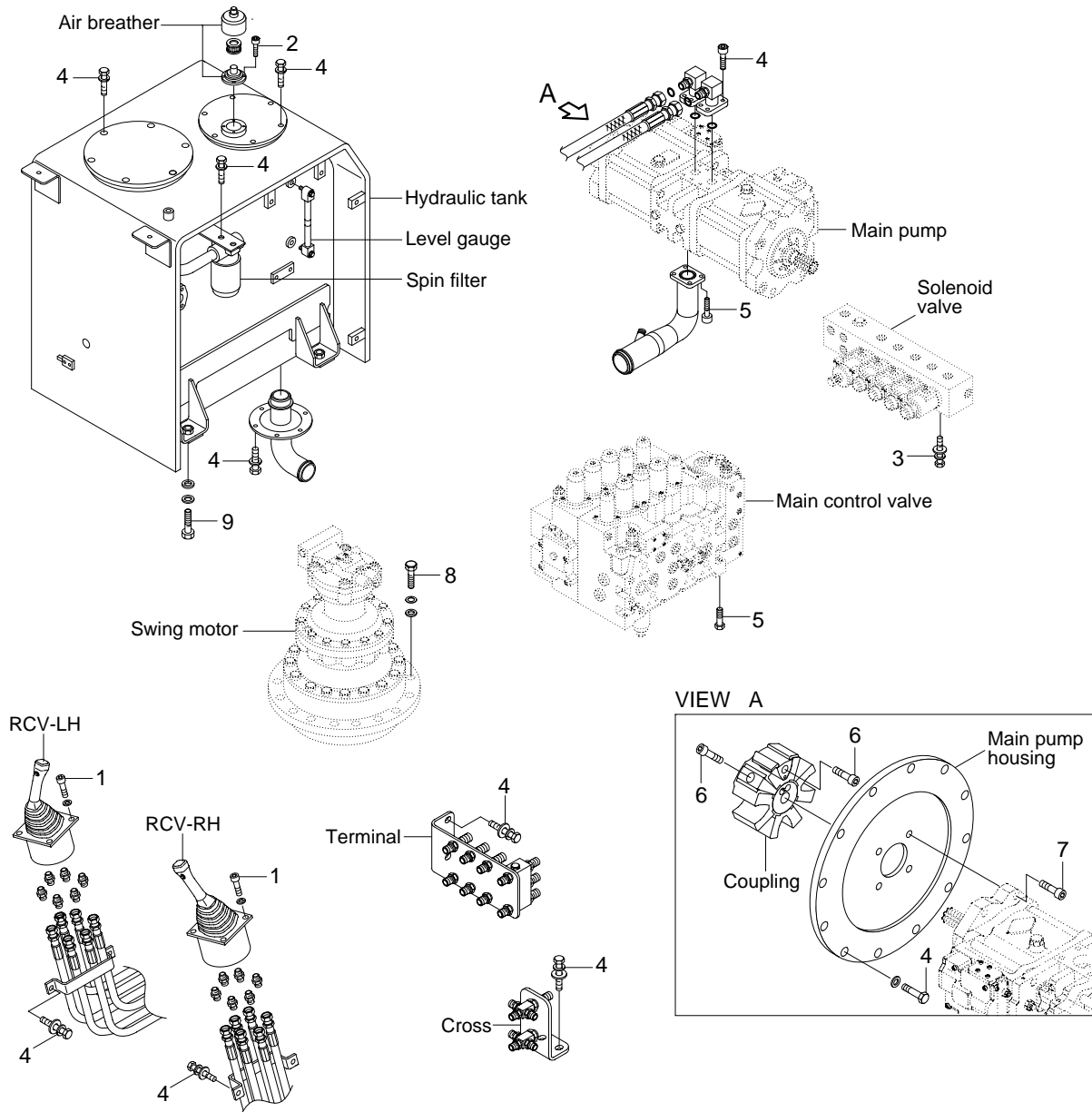

· Tightening torque

Item	Size	kgf · m	lbf · ft
1	M 6 × 1.0	1.05 ± 0.2	7.6 ± 1.45
2	M 6 × 1.0	1.44 ± 0.3	10.4 ± 2.2
3	M 8 × 1.25	2.5 ± 0.5	18.1 ± 3.6
4	M10 × 1.5	6.9 ± 1.4	49.9 ± 10.1
5	M12 × 1.75	12.2 ± 1.3	88.2 ± 9.4

Item	Size	kgf · m	lbf · ft
6	M16 × 2.0	22.0 ± 1.0	159 ± 7.2
7	M16 × 2.0	22.1 ± 2.4	160 ± 17.4
8	M16 × 2.0	29.7 ± 4.5	215 ± 32.5
9	M20 × 2.5	45 ± 5.1	325 ± 36.9
	-	-	-

## 2. HYDRAULIC COMPONENTS MOUNTING 2

Double acting attachment piping

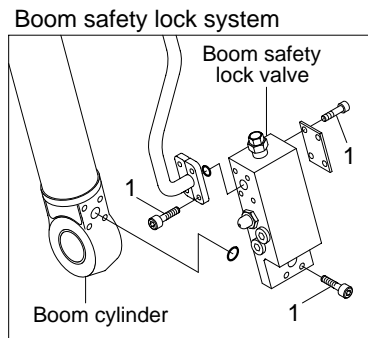
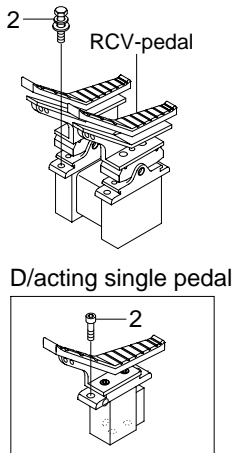
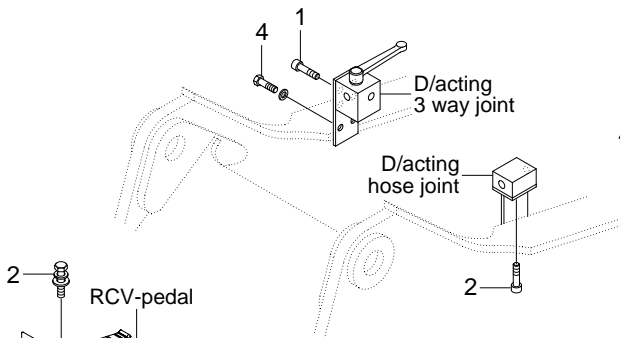
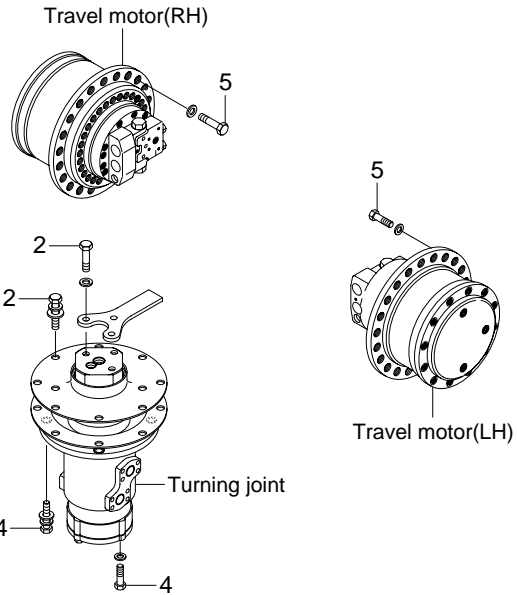
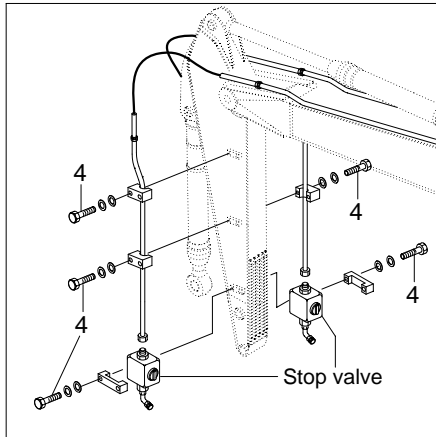

Arm safety lock system

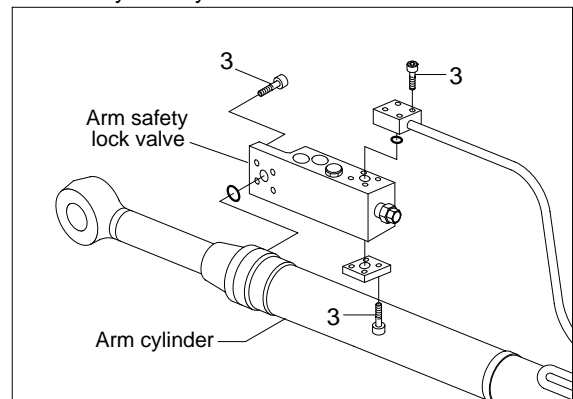

· Tightening torque

Item	Size	kgf · m	lbf · ft
1	M 8 × 1.25	4.05 ± 0.8	29.3 ± 5.8
2	M10 × 1.5	6.9 ± 1.4	49.9 ± 10.1
3	M10 × 1.5	8.27 ± 1.7	59.8 ± 12.3

Item	Size	kgf · m	lbf · ft
4	M12 × 1.75	12.8 ± 3.0	92.6 ± 21.7
5	M16 × 2.0	23 ± 2.5	166.3 ± 18.1
-	-	-	-

### 3. HYDRAULIC COMPONENTS MOUNTING 3

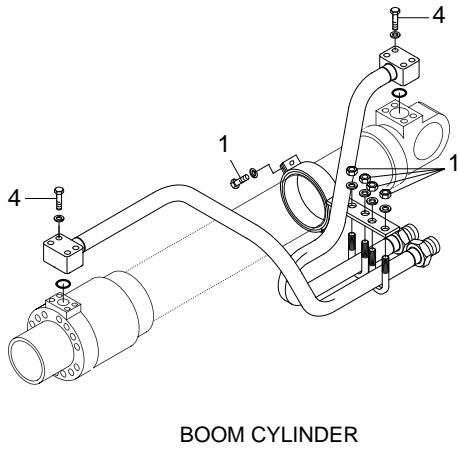

Solenoid valve

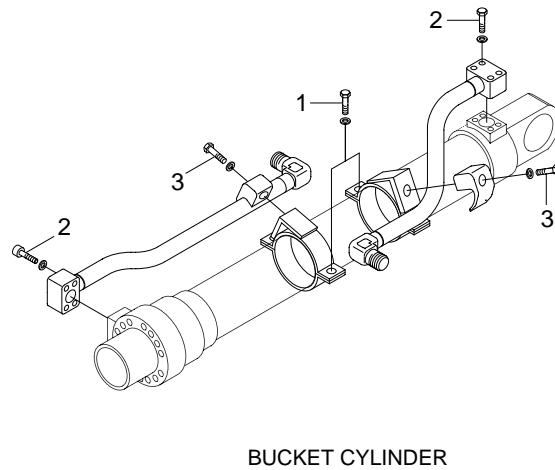
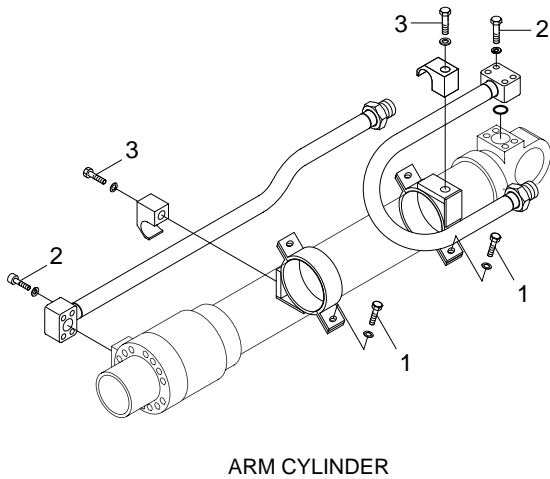
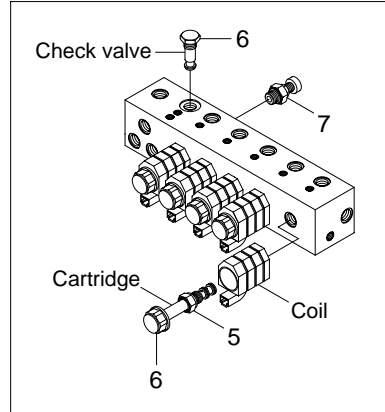

· Tightening torque

Item	Size	kgf · m	lbf · ft
1	M10 × 1.5	3.2 ± 0.3	23.1 ± 2.2
2	M10 × 1.5	5.4 ± 0.5	39.1 ± 3.6
3	M12 × 1.75	5.5 ± 0.6	39.8 ± 4.3
4	M18 × 1.25	2.7 ± 0.3	19.5 ± 2.2

Item	Size	kgf · m	lbf · ft
5	-	0.4	2.9
6	-	2.0	14.5
7	-	2.5	18.1

## GROUP 5 UNDERCARRIAGE

### ADJUST COMPONENT

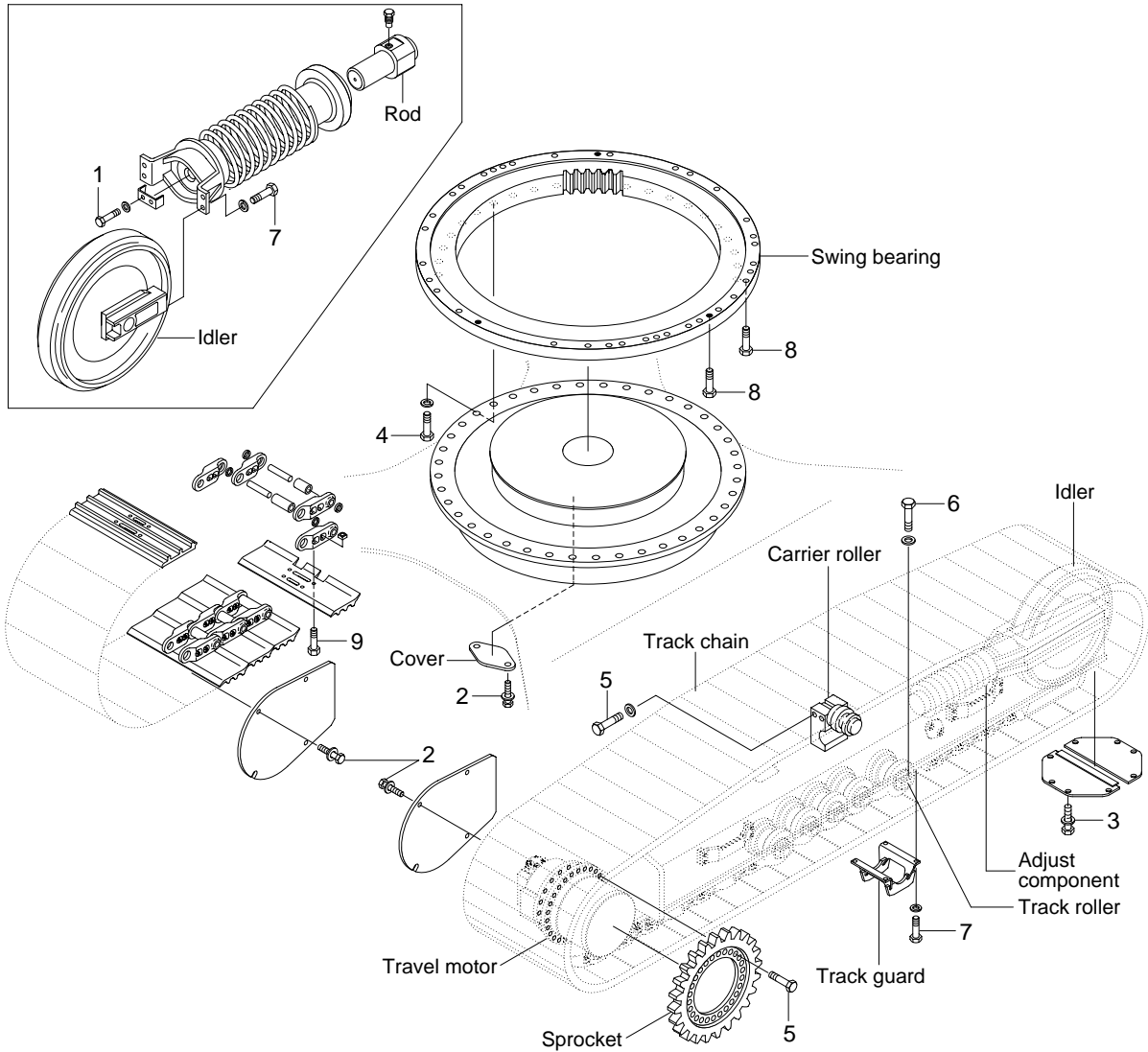

### · Tightening torque

Item	Size	kgf · m	lbf · ft
1	M 8 × 1.25	3.43 ± 0.7	24.8 ± 5.1
2	M10 × 1.5	6.9 ± 1.4	49.9 ± 10.1
3	M12 × 1.75	12.8 ± 3.0	92.6 ± 21.7
4	M16 × 1.5	31.3 ± 4.7	226 ± 34
5	M16 × 2.0	29.7 ± 4.5	215 ± 32.5

Item	Size	kgf · m	lbf · ft
6	M16 × 2.0	29.6 ± 3.2	214 ± 23.1
7	M16 × 2.0	29.7 ± 4.5	215 ± 32.5
8	M18 × 2.5	41.3 ± 6.2	299 ± 44.8
9	5/8"	42 ± 4.0	304 ± 29
-	-	-	-

# GROUP 6 STRUCTURE

## 1. CAB AND ACCESSORIES MOUNTING

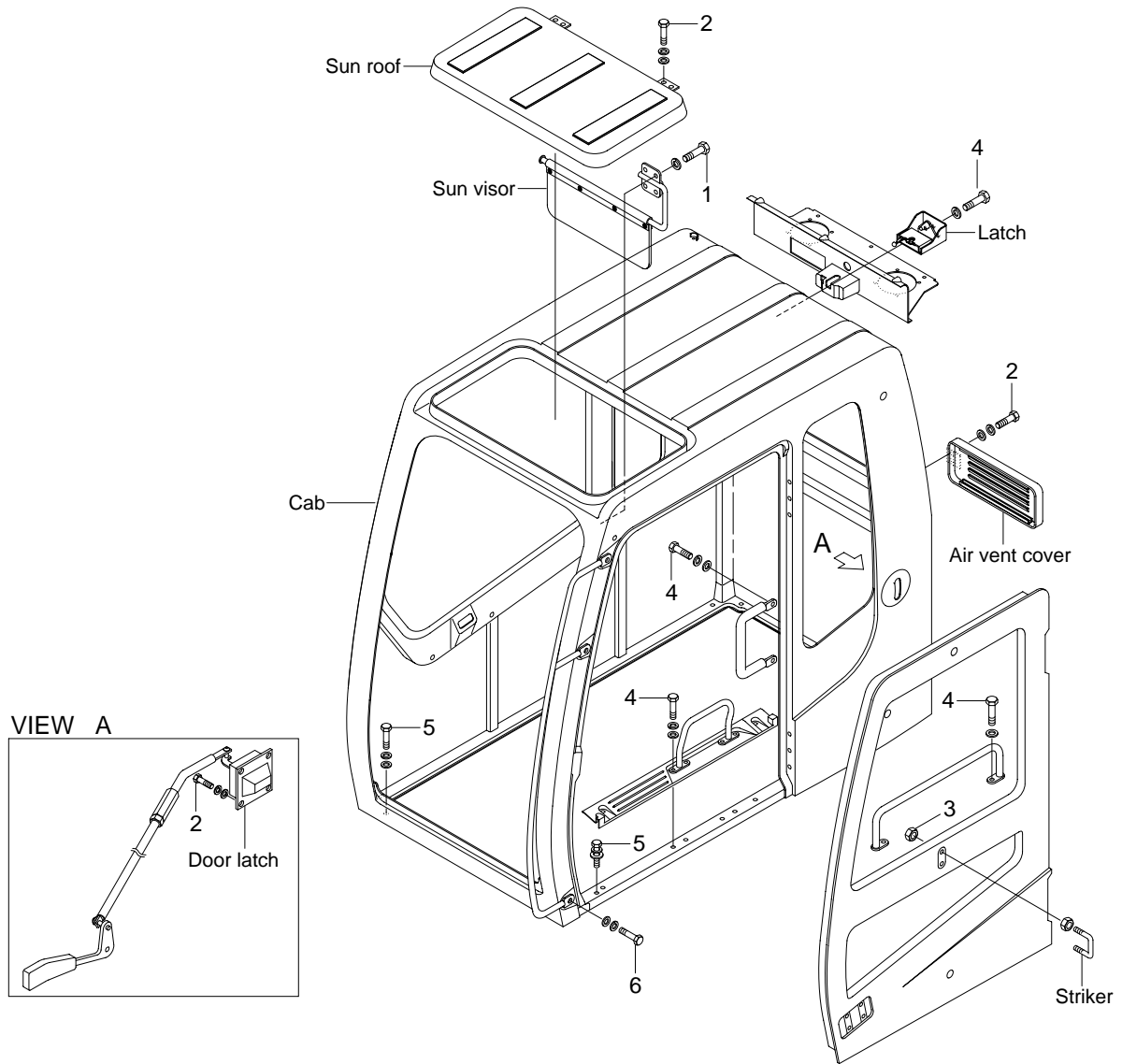

### · Tightening torque

Item	Size	kgf · m	lbf · ft
1	M 6 × 1.0	0.49 ± 0.1	3.5 ± 0.7
2	M 8 × 1.25	2.5 ± 0.5	18.1 ± 3.6
3	M10 × 1.5	4.7 ± 0.9	34 ± 6.5

Item	Size	kgf · m	lbf · ft
4	M10 × 1.5	6.9 ± 1.4	49.9 ± 10.1
5	M12 × 1.75	12.8 ± 3.0	92.6 ± 21.7
6	M16 × 2.0	29.7 ± 4.5	215 ± 32.5

## 2. CAB INTERIOR MOUNTING

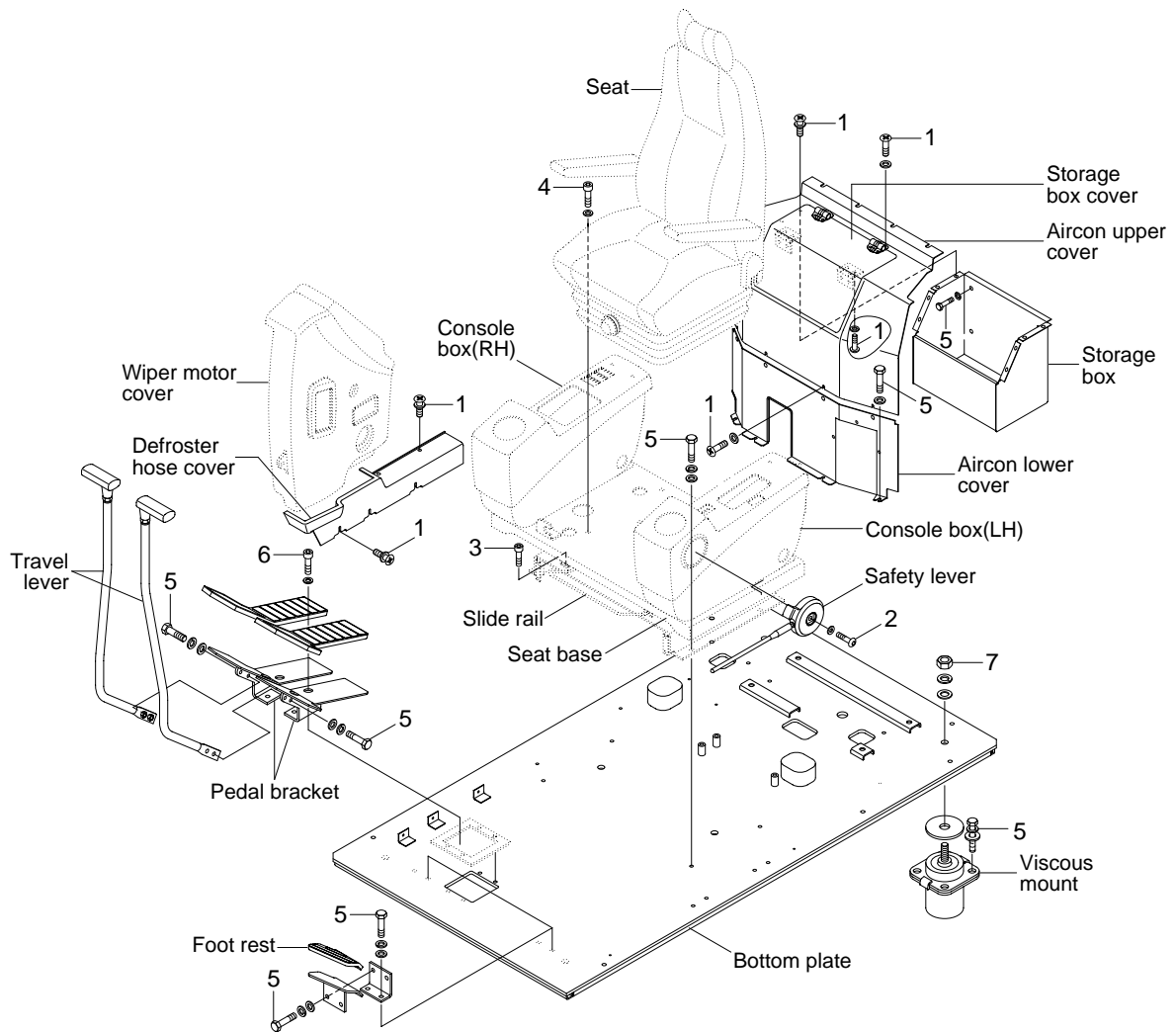

### · Tightening torque

Item	Size	kgf · m	lbf · ft
1	M 6 × 1.0	0.49 ± 0.1	3.5 ± 0.7
2	M 6 × 1.0	1.05 ± 0.2	7.6 ± 1.4
3	M 8 × 1.25	3.43 ± 0.7	24.8 ± 5.1
4	M 8 × 1.25	4.05 ± 0.8	29.3 ± 5.8

Item	Size	kgf · m	lbf · ft
5	M10 × 1.5	6.9 ± 1.4	49.9 ± 10.1
6	M10 × 1.5	8.27 ± 1.7	59.8 ± 12.3
7	M16 × 2.0	29.7 ± 4.5	215 ± 32.5
-	-	-	-

### 3. COWLING MOUNTING

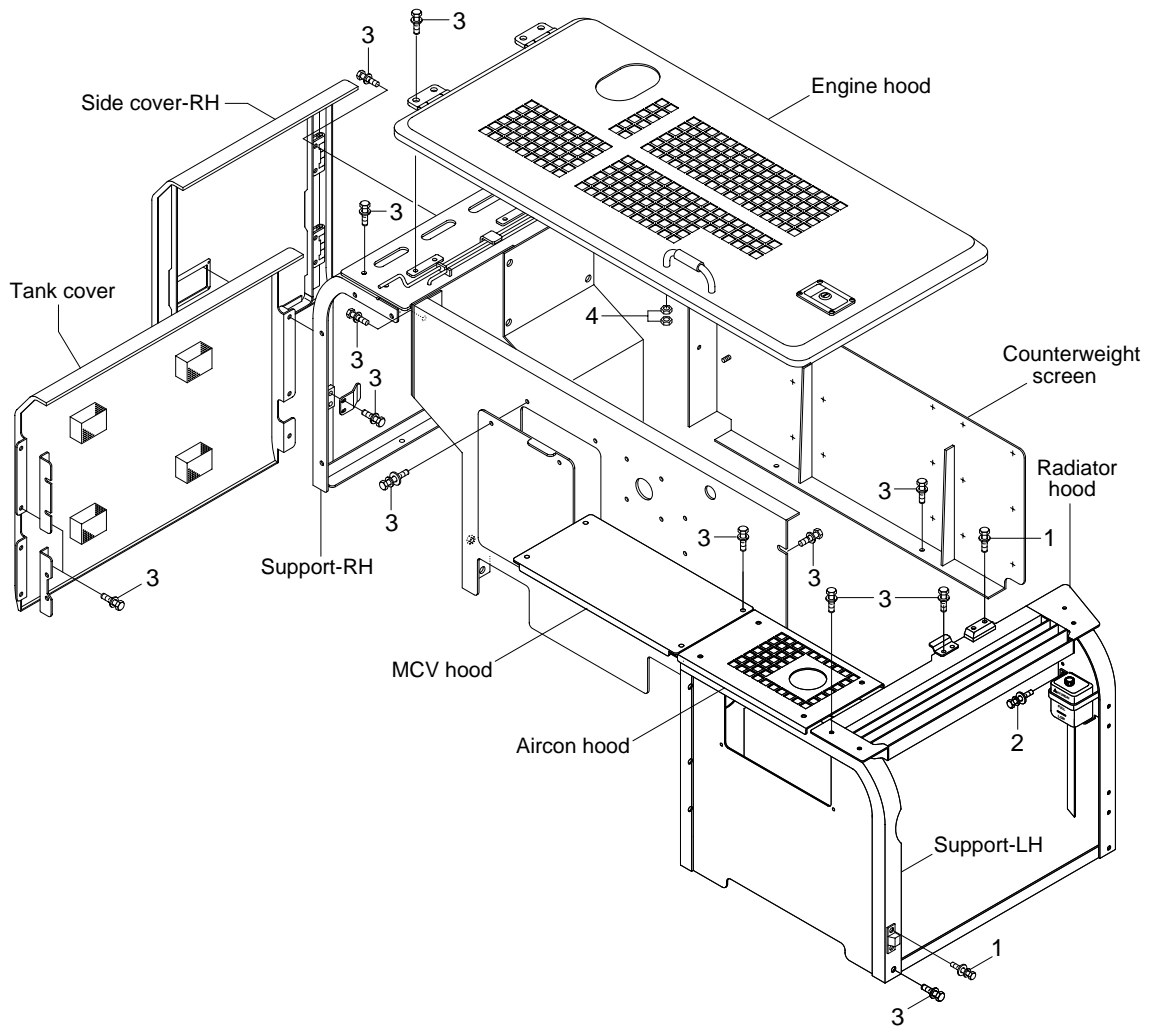

· Tightening torque

Item	Size	kgf · m	lbf · ft
1	M 6 × 1.0	0.49 ± 0.1	3.5 ± 0.7
2	M 8 × 1.25	2.5 ± 0.5	18.1 ± 3.6

Item	Size	kgf · m	lbf · ft
3	M12 × 1.75	12.8 ± 3.0	92.6 ± 21.7
4	M16 × 2.0	29.7 ± 4.5	215 ± 32.5

#### 4. COUNTERWEIGHT AND COVERS MOUNTING

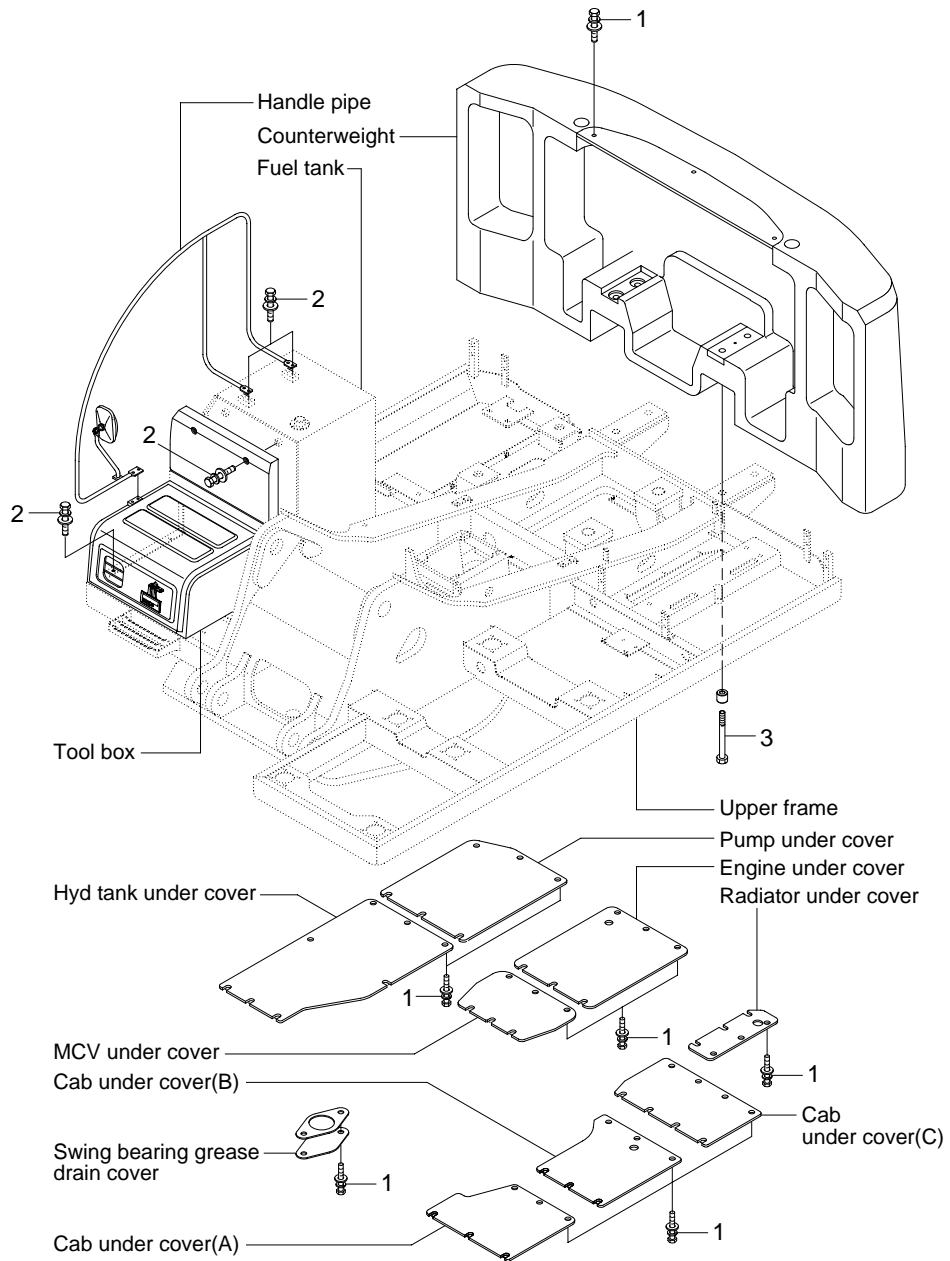

· Tightening torque

Item	Size	kgf · m	lbf · ft
1	M10 × 1.5	6.9 ± 1.4	49.9 ± 10.1
2	M12 × 1.75	12.8 ± 3.0	92.6 ± 21.7

Item	Size	kgf · m	lbf · ft
3	M27 × 3.0	140 ± 15	1013 ± 108
-	-	-	-

## GROUP 7 WORK EQUIPMENT

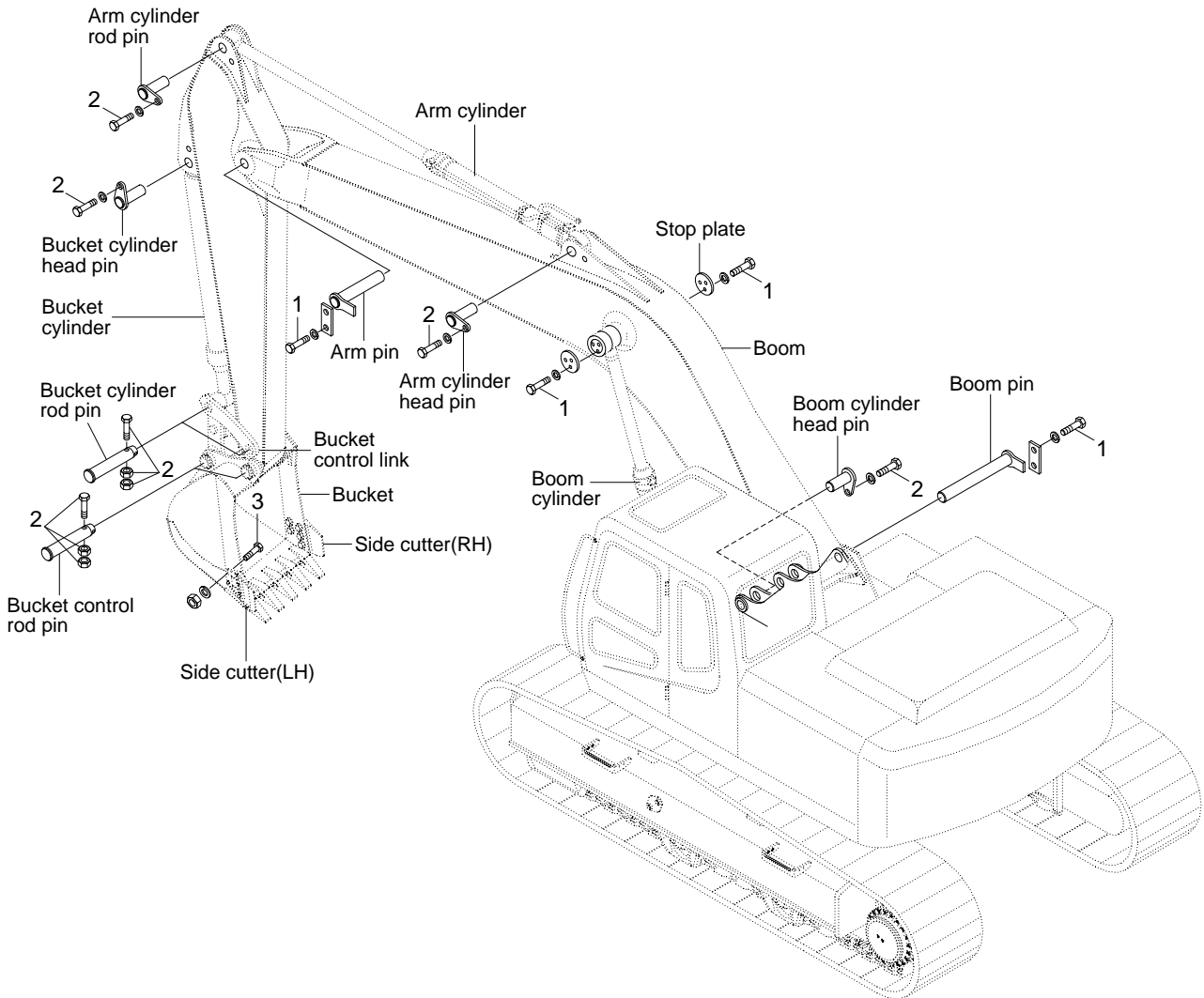

### · Tightening torque

Item	Size	kgf · m	lbf · ft
1	M12 × 1.75	12.8 ± 3.0	92.6 ± 21.7
2	M16 × 2.0	29.7 ± 4.5	215 ± 32.5

Item	Size	kgf · m	lbf · ft
3	M20 × 2.5	57.9 ± 8.7	419 ± 62.9
-	-	-	-