

SECTION 6 TROUBLESHOOTING

Group 1 Before Troubleshooting	6-1
Group 2 Hydraulic and Mechanical System	6-4
Group 3 Electrical System	6-24
Group 4 Mechatronics System	6-41

GROUP 1 BEFORE TROUBLESHOOTING

1. INTRODUCTION

When a trouble is occurred in the machine, this section will help an operator to maintain the machine with easy.

The trouble of machine is parted Hydraulic & Mechanical system, Electrical system and Mechatronics system. At each system part, an operator can check the machine according to the troubleshooting process diagram.

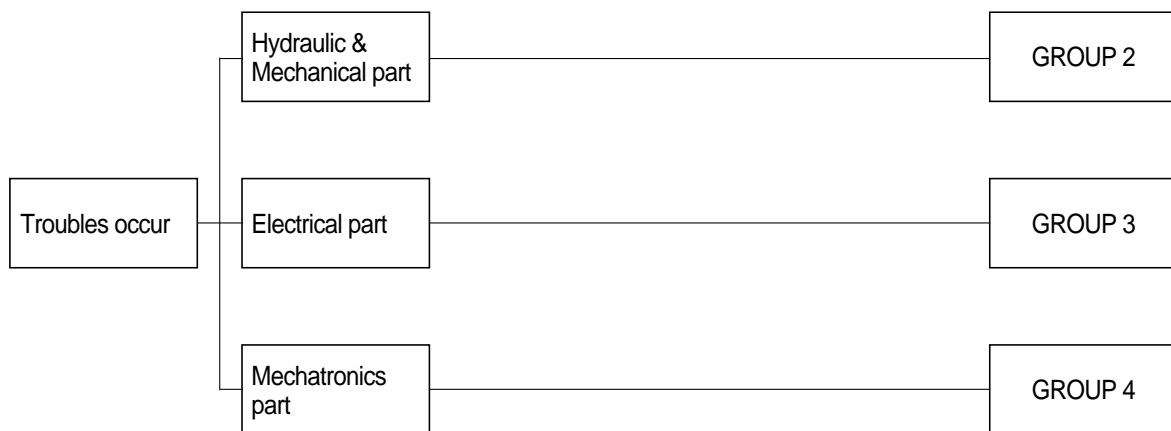

2. DIAGNOSING PROCEDURE

To carry out troubleshooting efficiently, the following steps must be observed.

STEP 1. Study the machine system

Study and know how the machine is operating, how the system is composing, what kinds of function are installed in the machine and what are specifications of the system components by the machine service manual.

Especially, deepen the knowledge for the related parts of the trouble.

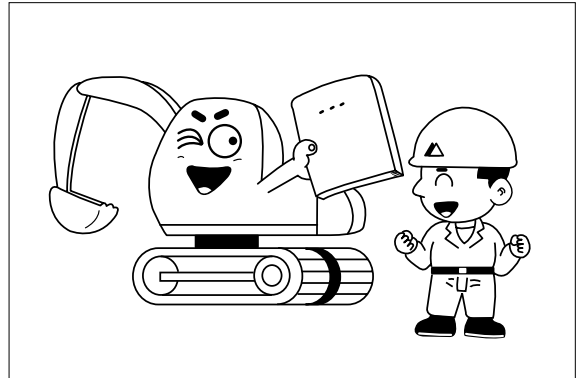

STEP 2. Ask the operator

Before inspecting, get the full story of malfunctions from a witness --- the operator.

- 1) How the machine is used and when it is serviced?
- 2) When the trouble was noticed and what work the machine was doing at that time?
- 3) What is the phenomenon of the trouble?
Was the trouble getting worse, or did it come out suddenly for the first time?
- 4) Did the machine have any troubles previously? If so, which parts were repaired before.

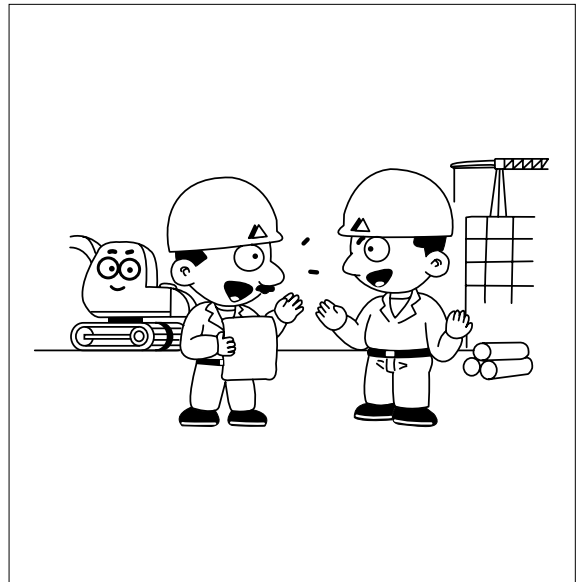

STEP 3. Inspect the machine

Before starting troubleshooting, check the machine for the daily maintenance points as shown in the operator's manual.

And also check the electrical system including batteries, as the troubles in the electrical system such as low battery voltage, loose connections and blown out fuses will result in malfunction of the controllers causing total operational failures of the machine.

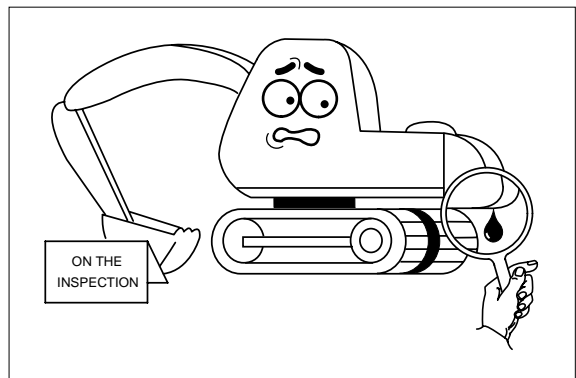

STEP 4. Inspect the trouble actually on the machine

In case that some trouble cannot be confirmed, obtain the details of the malfunction from the operator.

Also, check if there are any incomplete connections of the wire harnesses or not.

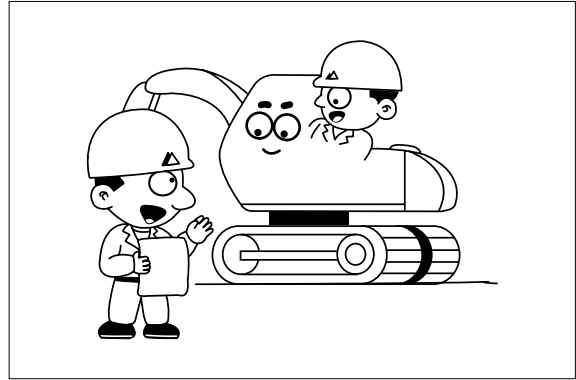

STEP 5. Perform troubleshooting

According to where the trouble parts are located, hydraulic & mechanical system part or electrical system part or mechatronics system part, perform troubleshooting the machine refer to the each system part's troubleshooting process diagram.

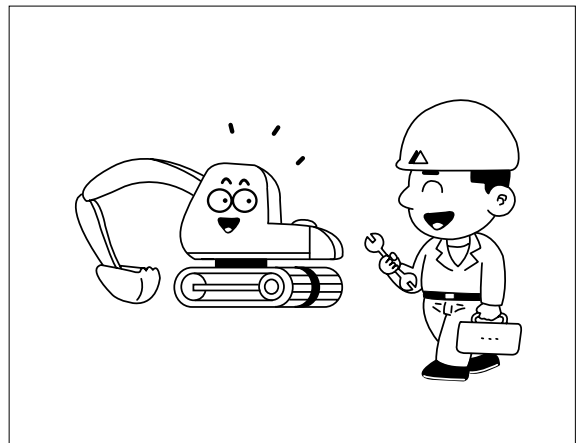

STEP 6. Trace a cause

Before reaching a conclusion, check the most susceptible causes again. Try to trace what the real cause of the trouble is.

Make a plan of the appropriate repairing procedure to avoid consequential malfunctions.

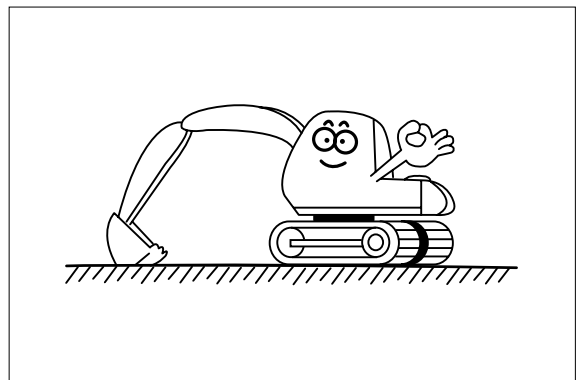

GROUP 2 HYDRAULIC AND MECHANICAL SYSTEM

1. INTRODUCTION

1) MACHINE IN GENERAL

- (1) If even a minor fault is left intact and operation is continued, a fatal failure may be caused, entailing a large sum of expenses and long hours of restoration.
Therefore when even a small trouble occurs, do not rely on your intuition and experience, but look for the cause based on the troubleshooting principle and perform maintenance and adjustment to prevent major failure from occurring. Keep in mind that a fault results from a combination of different causes.
- (2) The following lists up commonly occurring faults and possible causes with this machine. For the troubleshooting of the engine, refer to the coming troubleshooting and repair.
- (3) When carrying out troubleshooting, do not hurry to disassemble the components.
It will become impossible to find the cause of the problem.
- (4) Ask user or operator the following.
Was there any strange thing about machine before failure occurred?
Under what conditions did the failure occur?
Have any repairs been carried out before the failure?
- (5) Check before troubleshooting.
Check oil and fuel level.
Check for any external leakage of oil from components.
Check for loose or damage of wiring and connections.

2. DRIVE SYSTEM

1) UNUSUAL NOISE COMES OUT OF PUMP CONNECTION

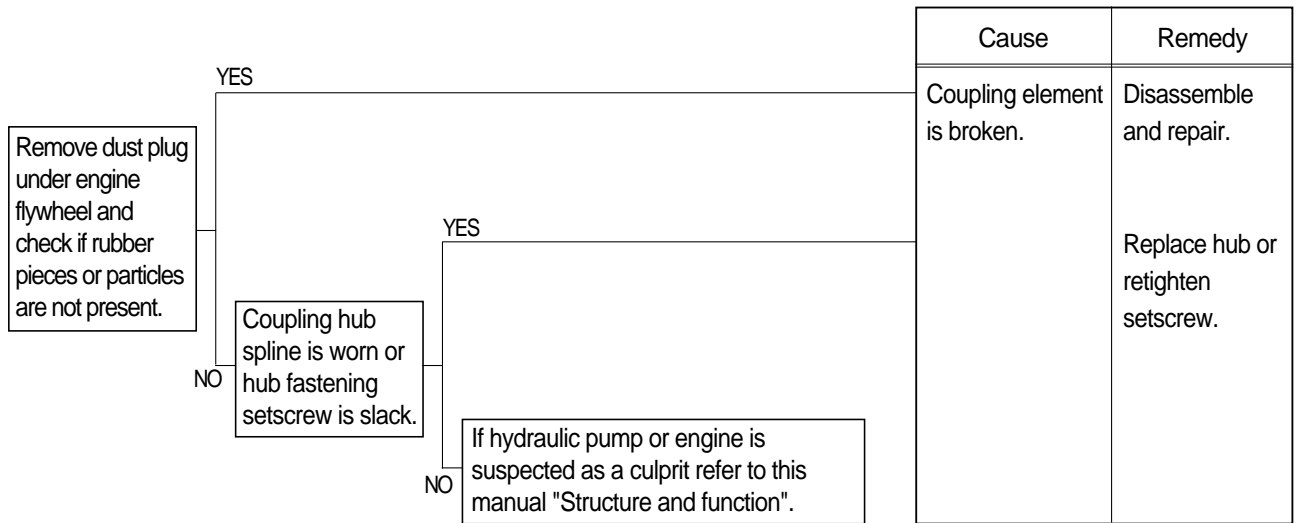

2) ENGINE STARTS BUT MACHINE DOES NOT OPERATE AT ALL

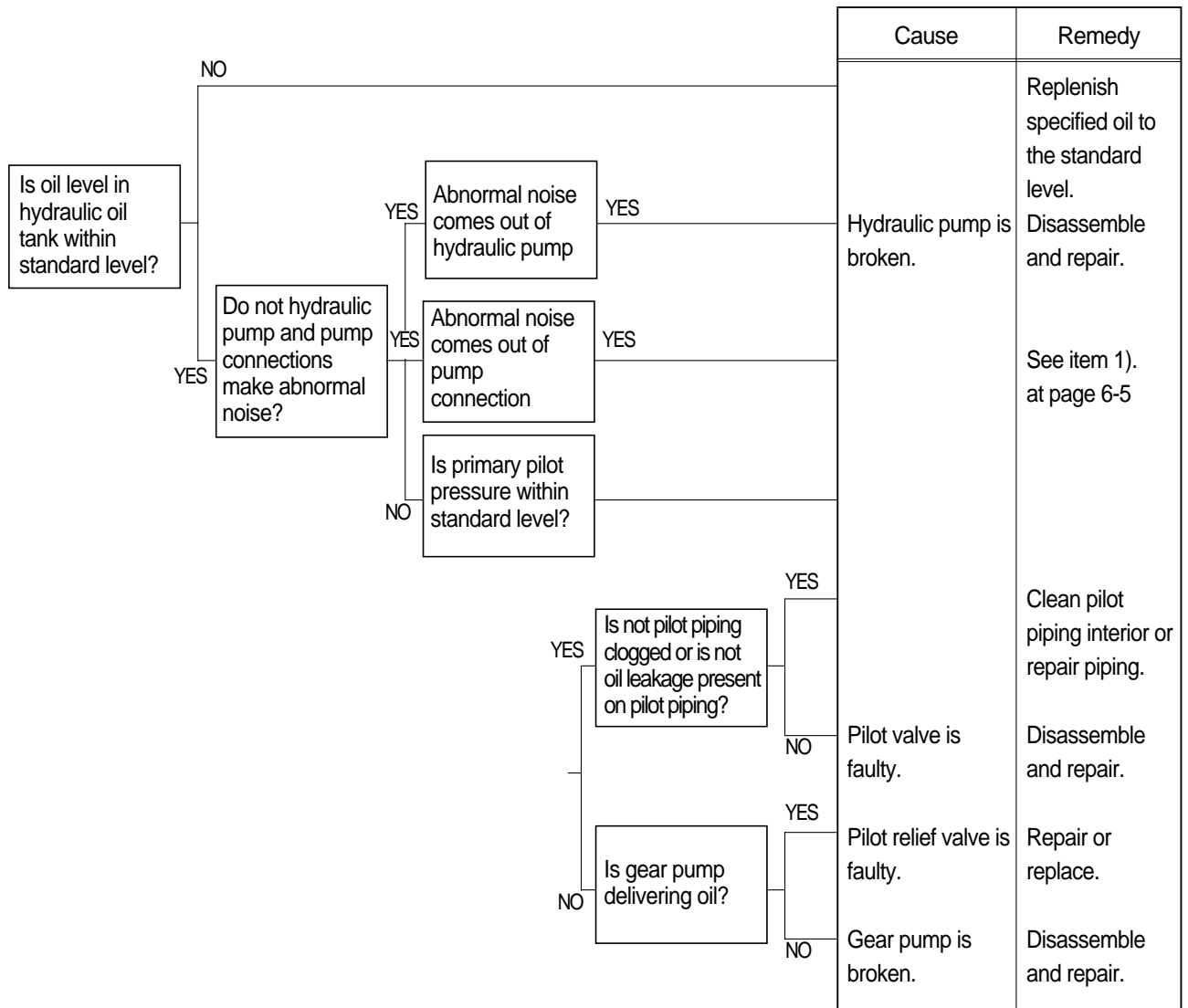

3. HYDRAULIC SYSTEM

1) HYDRAULIC OIL IS CLOUDY

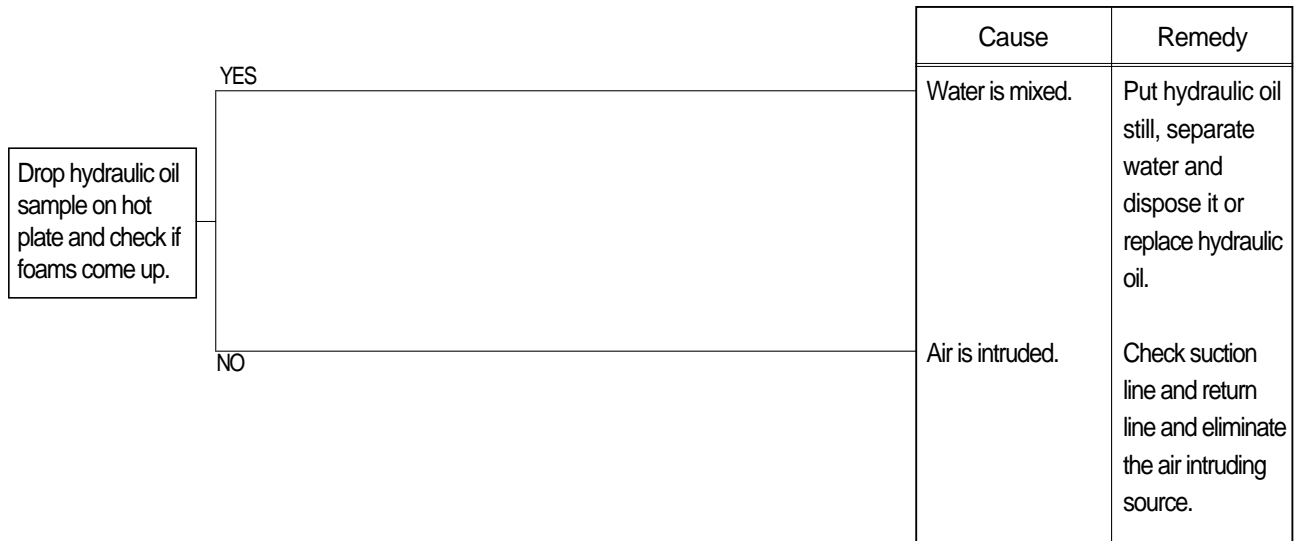

2) HYDRAULIC OIL TEMPERATURE HAS RISEN ABNORMALLY

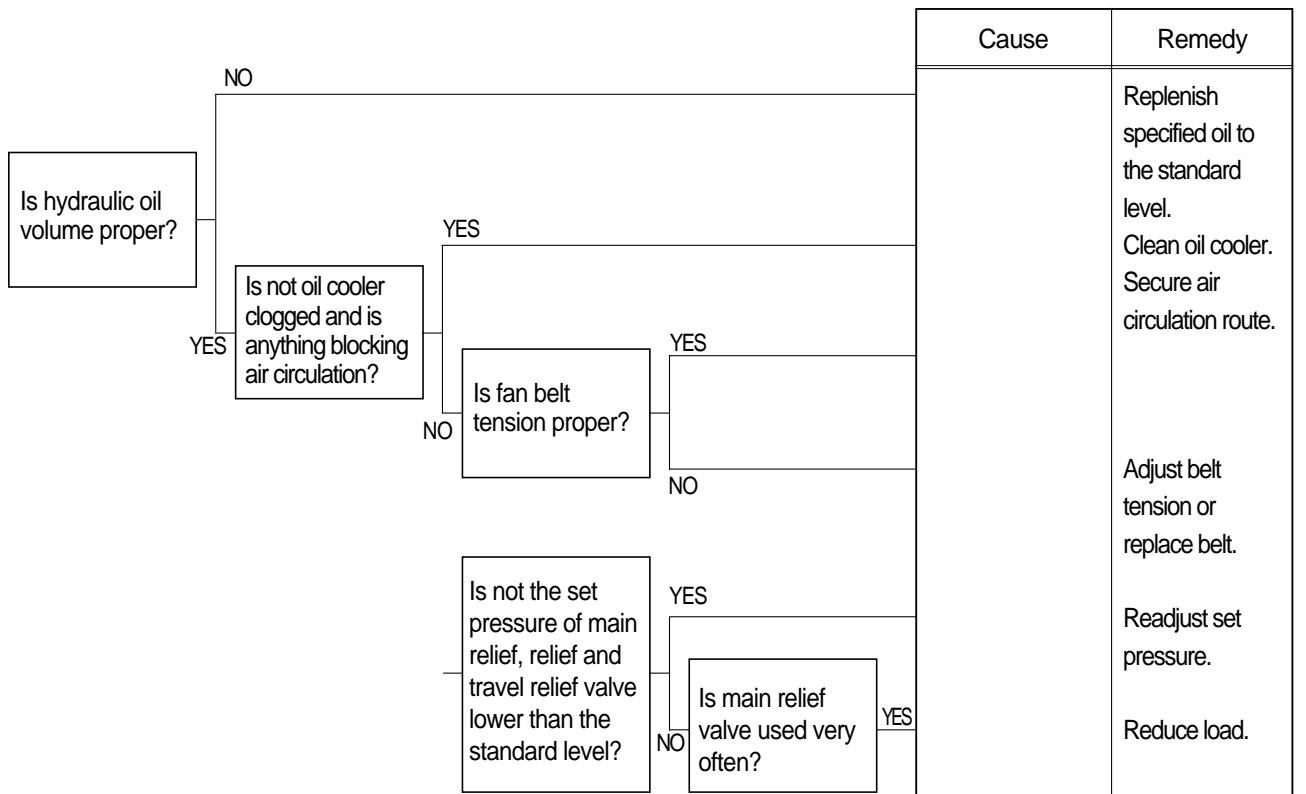

3) CAVITATION OCCURS WITH PUMP

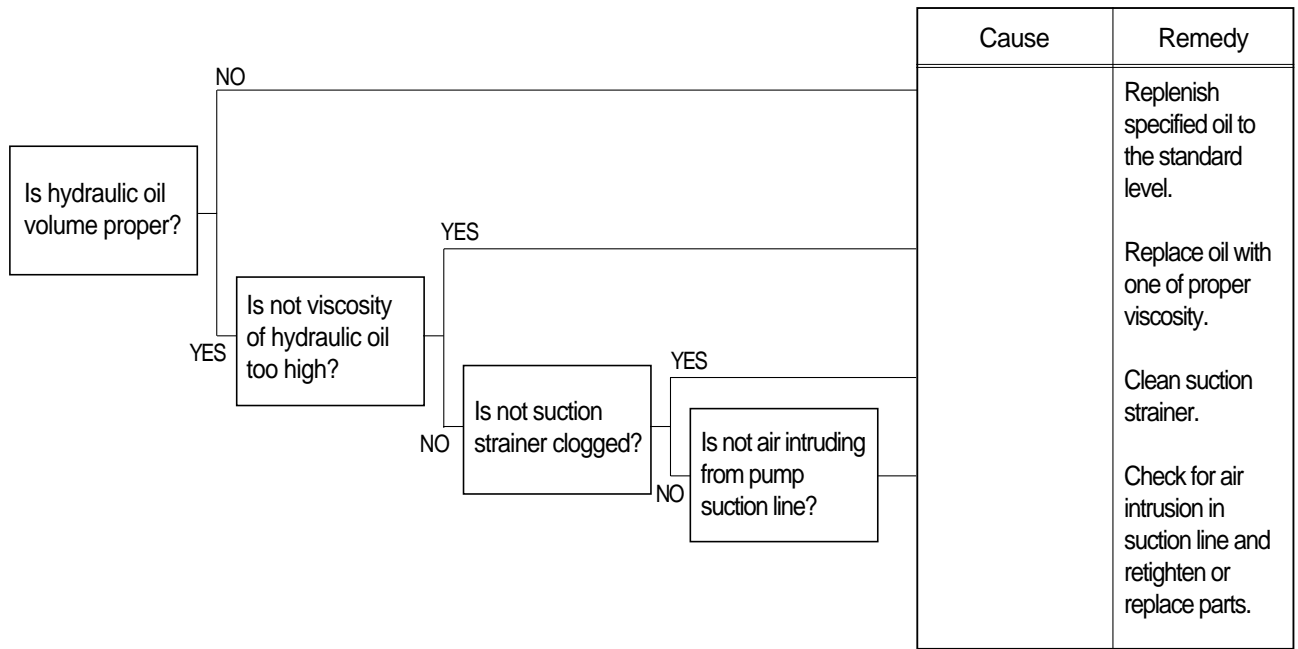

4) HYDRAULIC OIL IS CONTAMINATED

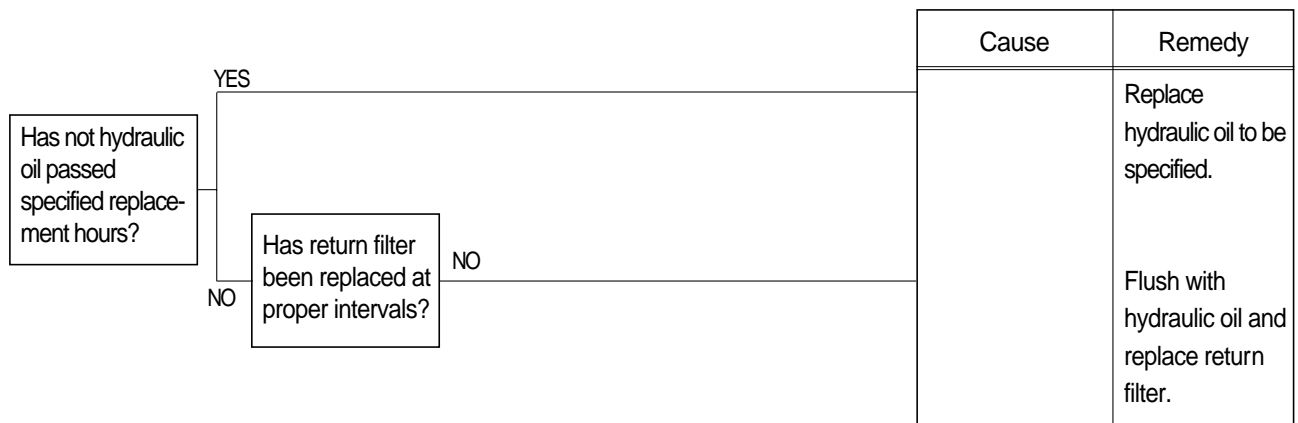

4. SWING SYSTEM

1) BOTH LH AND RH SWING ACTIONS ARE IMPOSSIBLE

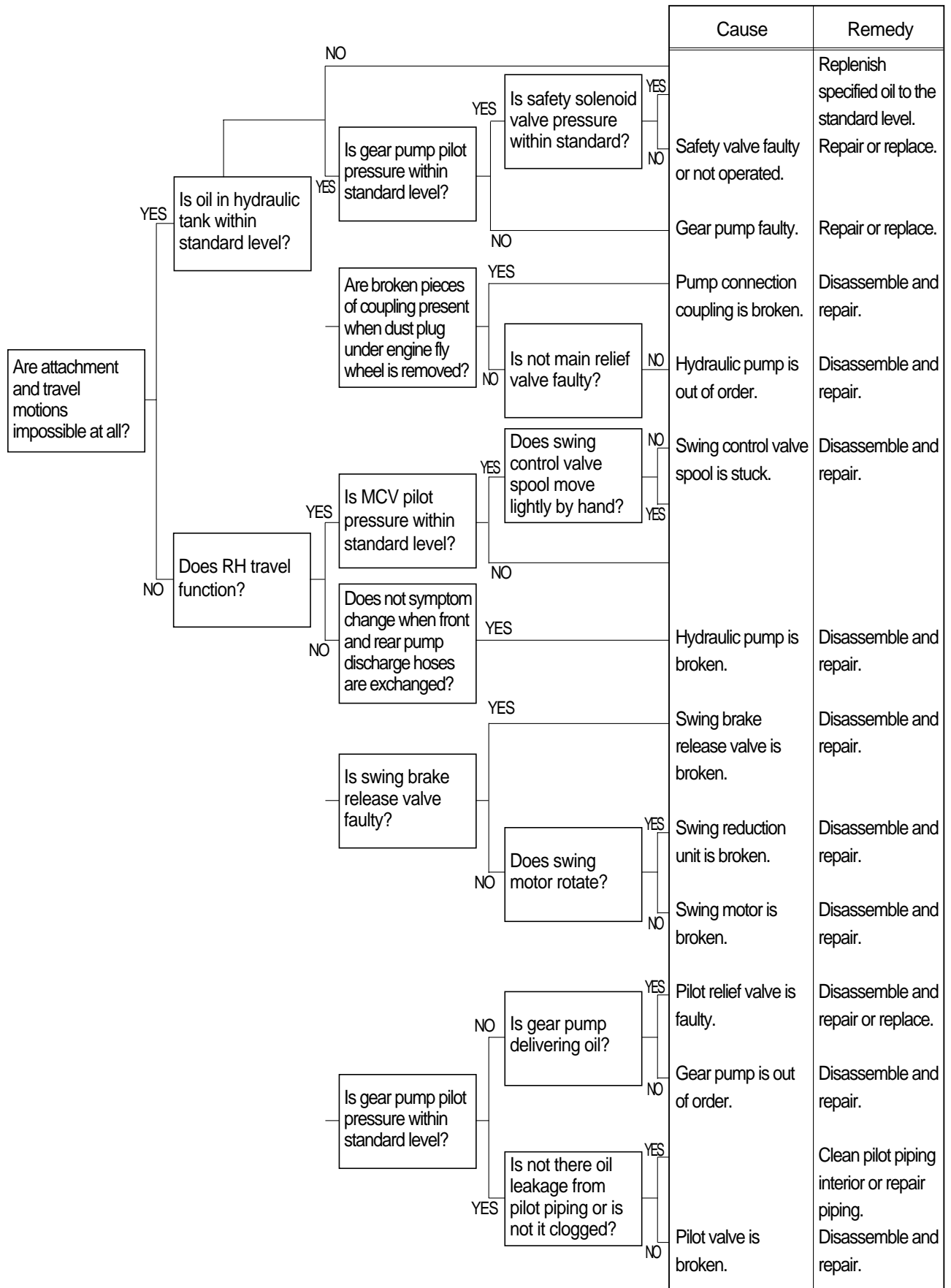

2) SWING SPEED IS LOW

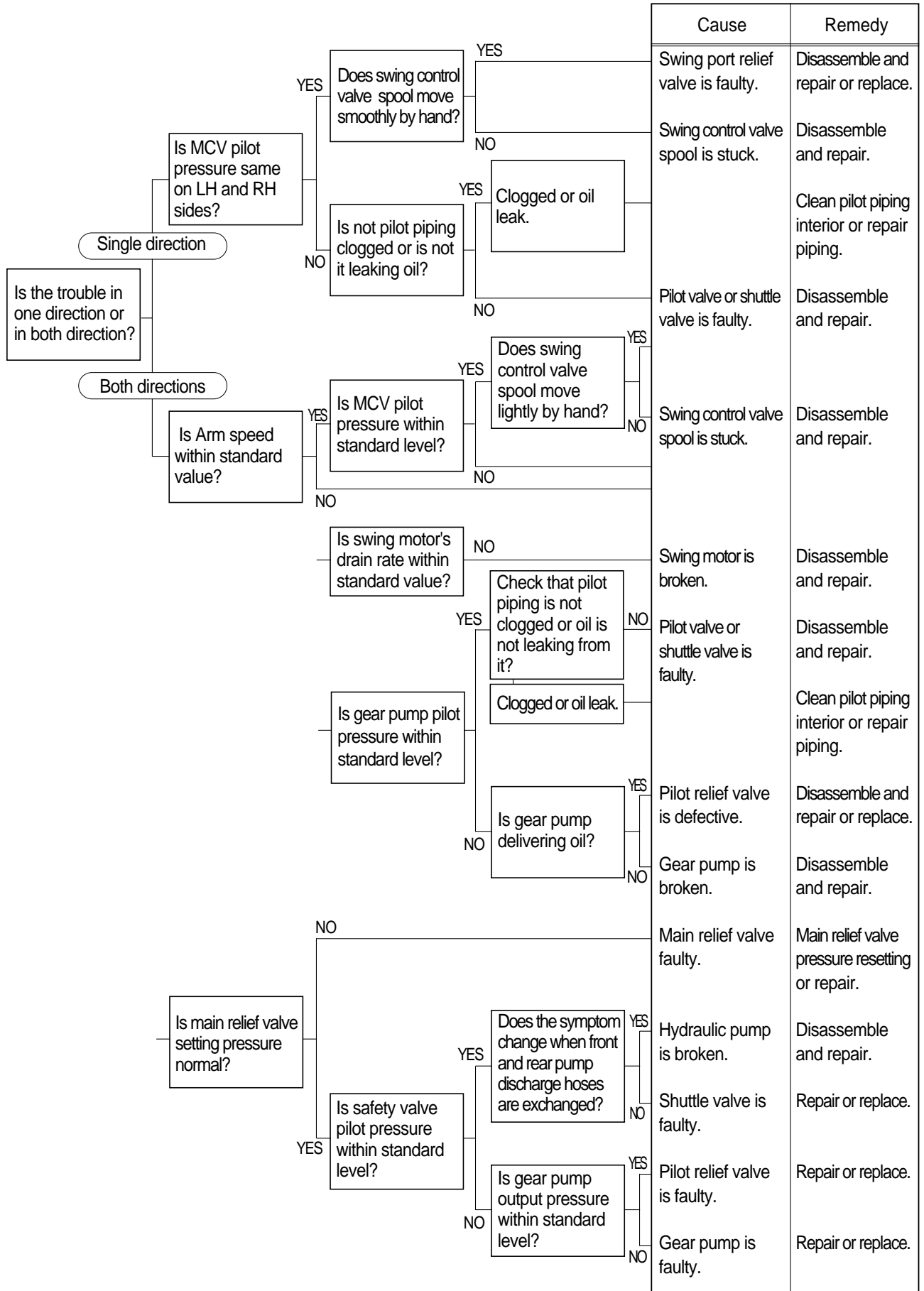

3) SWING MOTION IS IMPOSSIBLE IN ONE DIRECTION

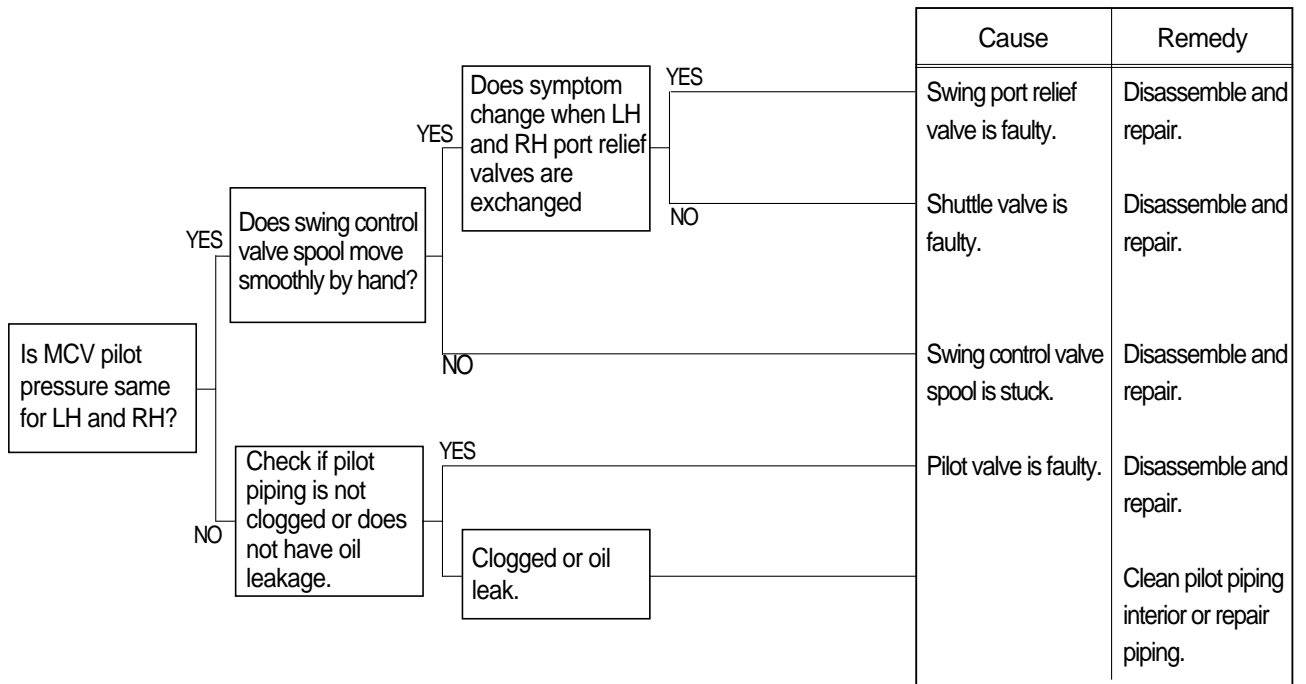

4) MACHINE SWINGS BUT DOES NOT STOP

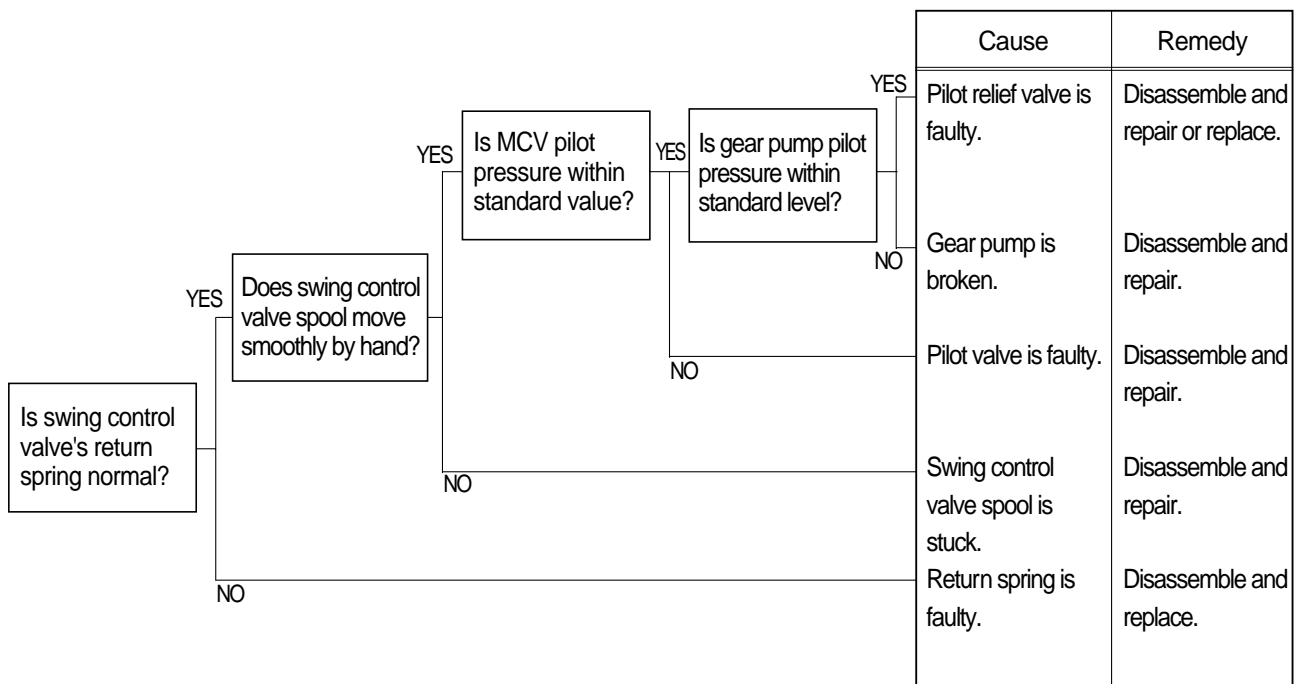

5) THE SWING UNIT DRIFTS WHEN THE MACHINE IS AT REST ON A SLOPE

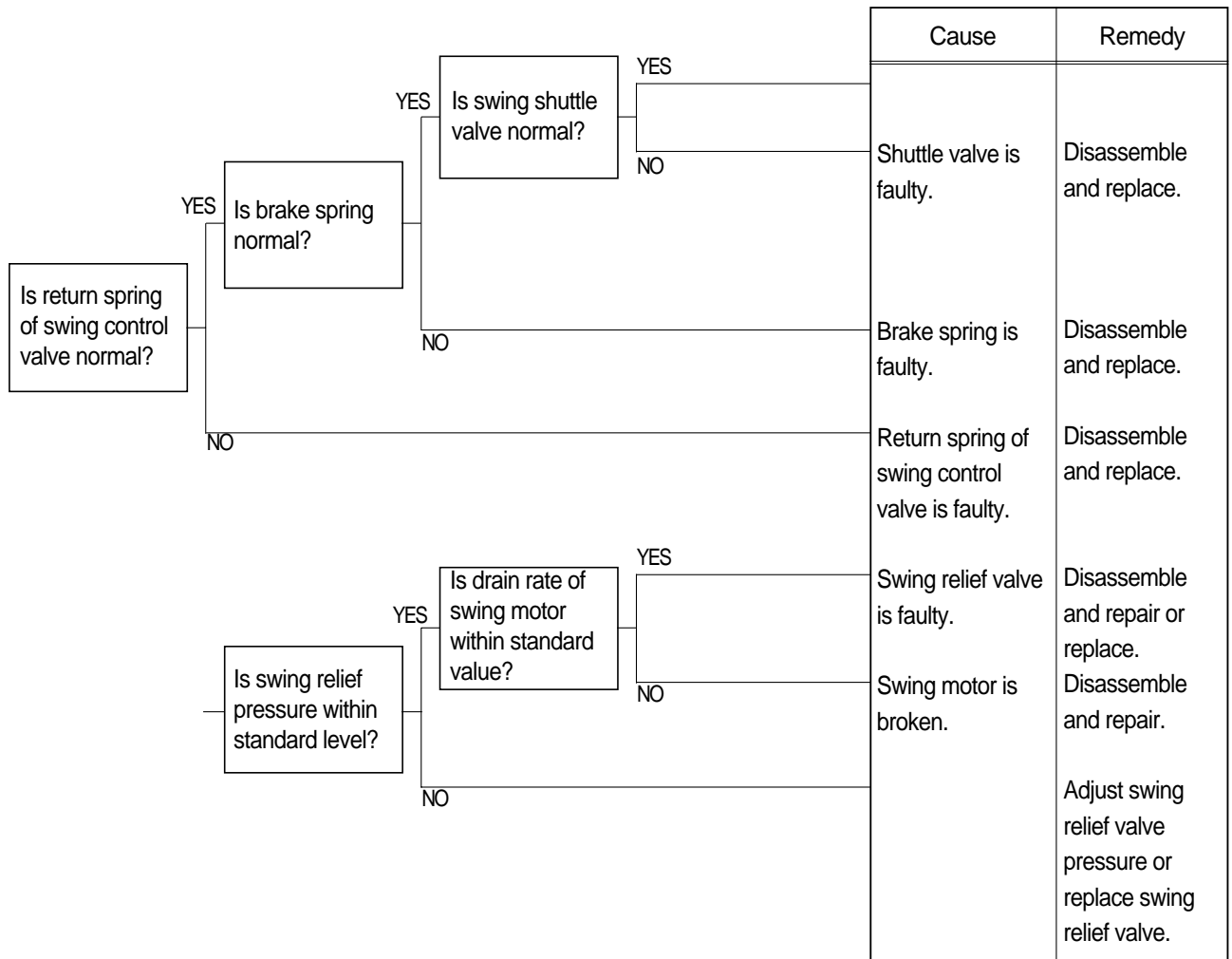

5. TRAVEL SYSTEM

1) TRAVEL DOES NOT FUNCTION AT ALL ON ONE SIDE

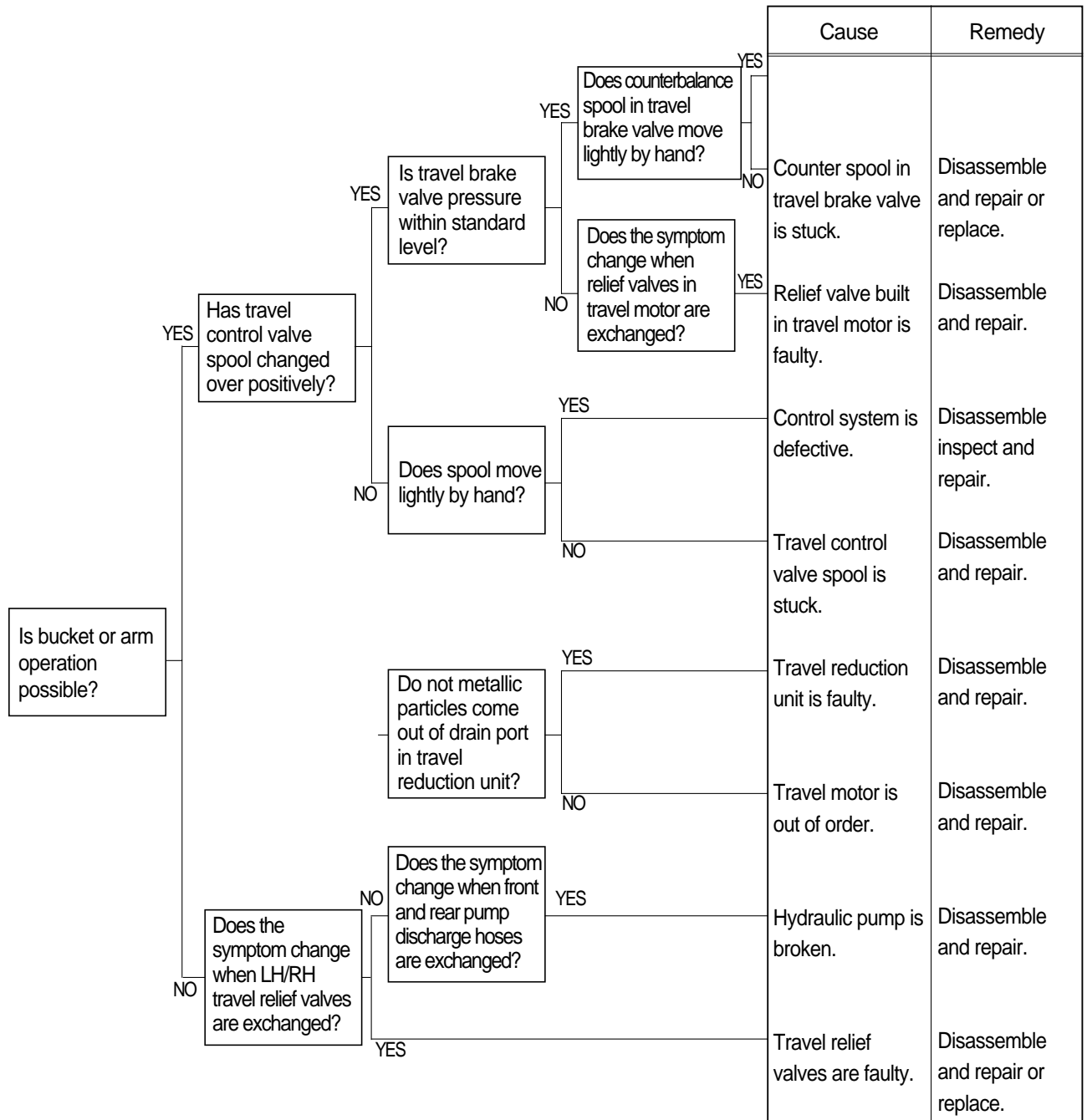

2) SPEED ON ONE SIDE FALLS AND THE MACHINE CURVES

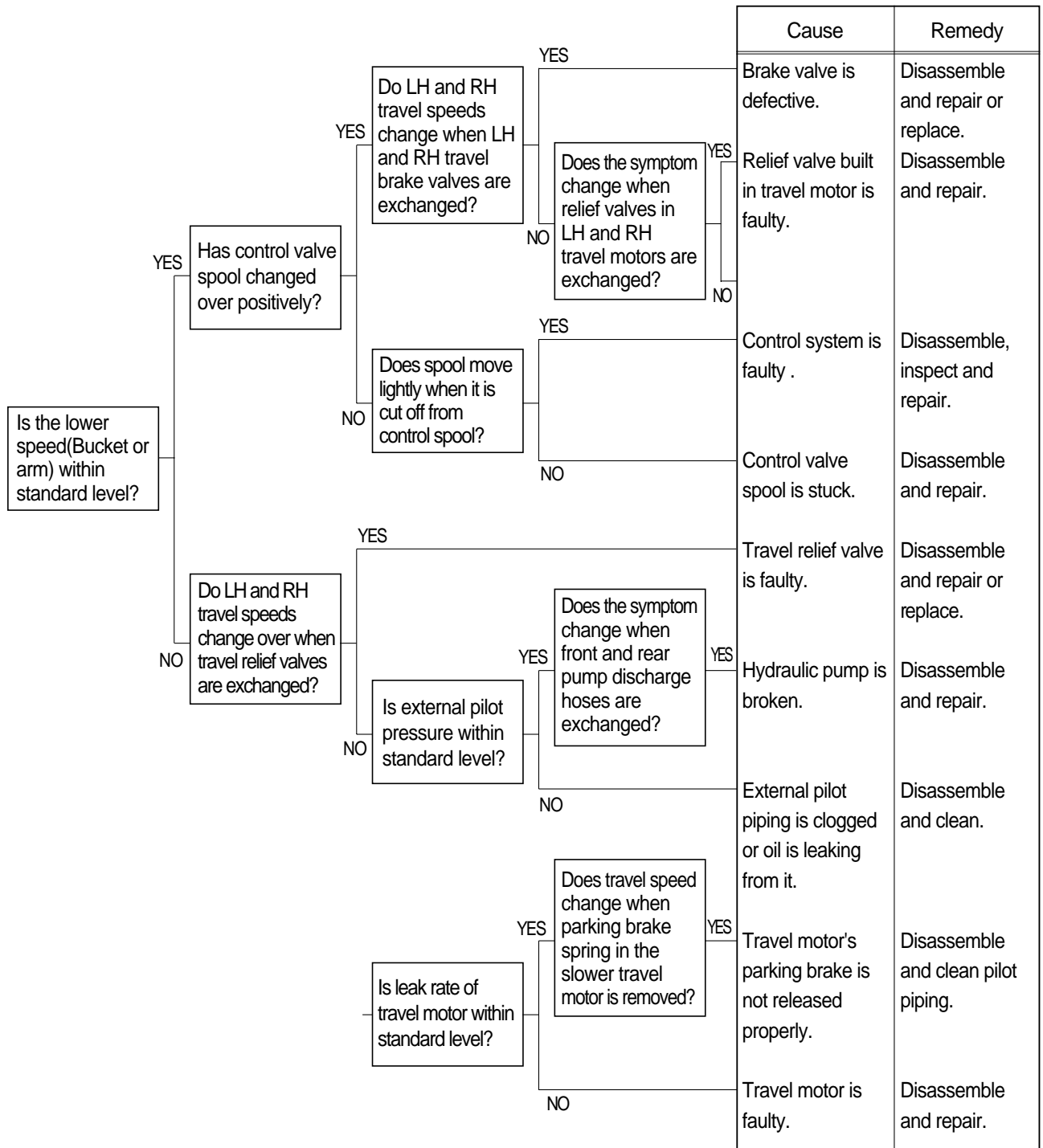

3) MACHINE DOES NOT STOP ON A SLOPE

Machine is pulled forward as sprocket rotates during digging operation.

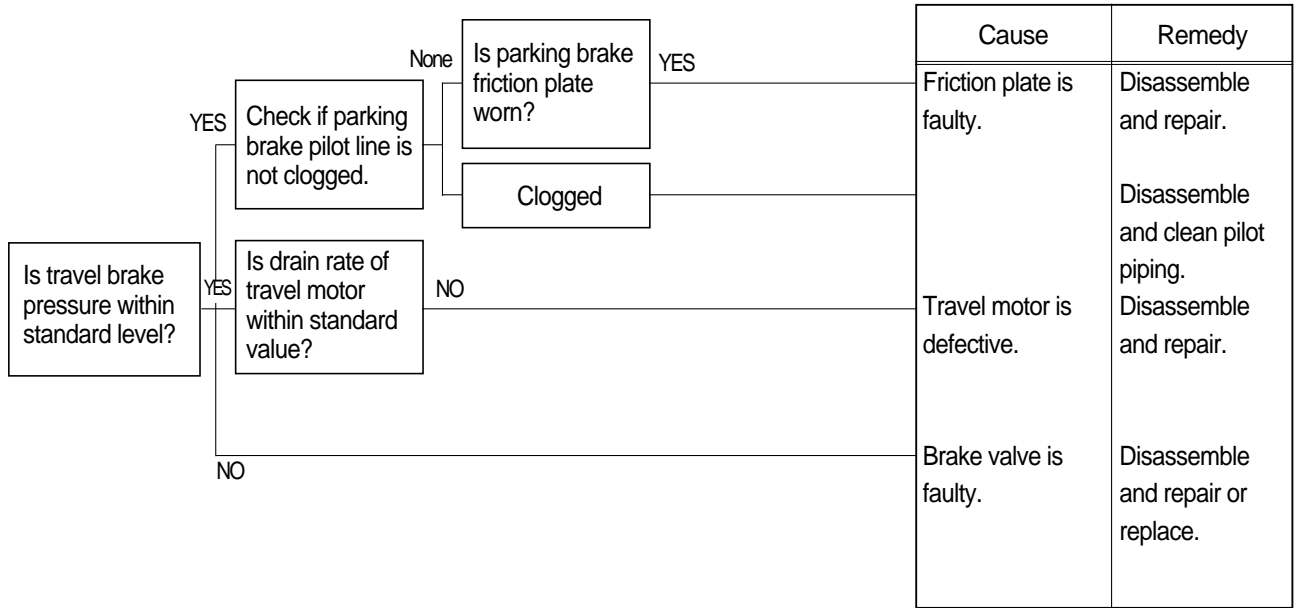

4) LH AND RH TRAVEL MOTIONS ARE IMPOSSIBLE

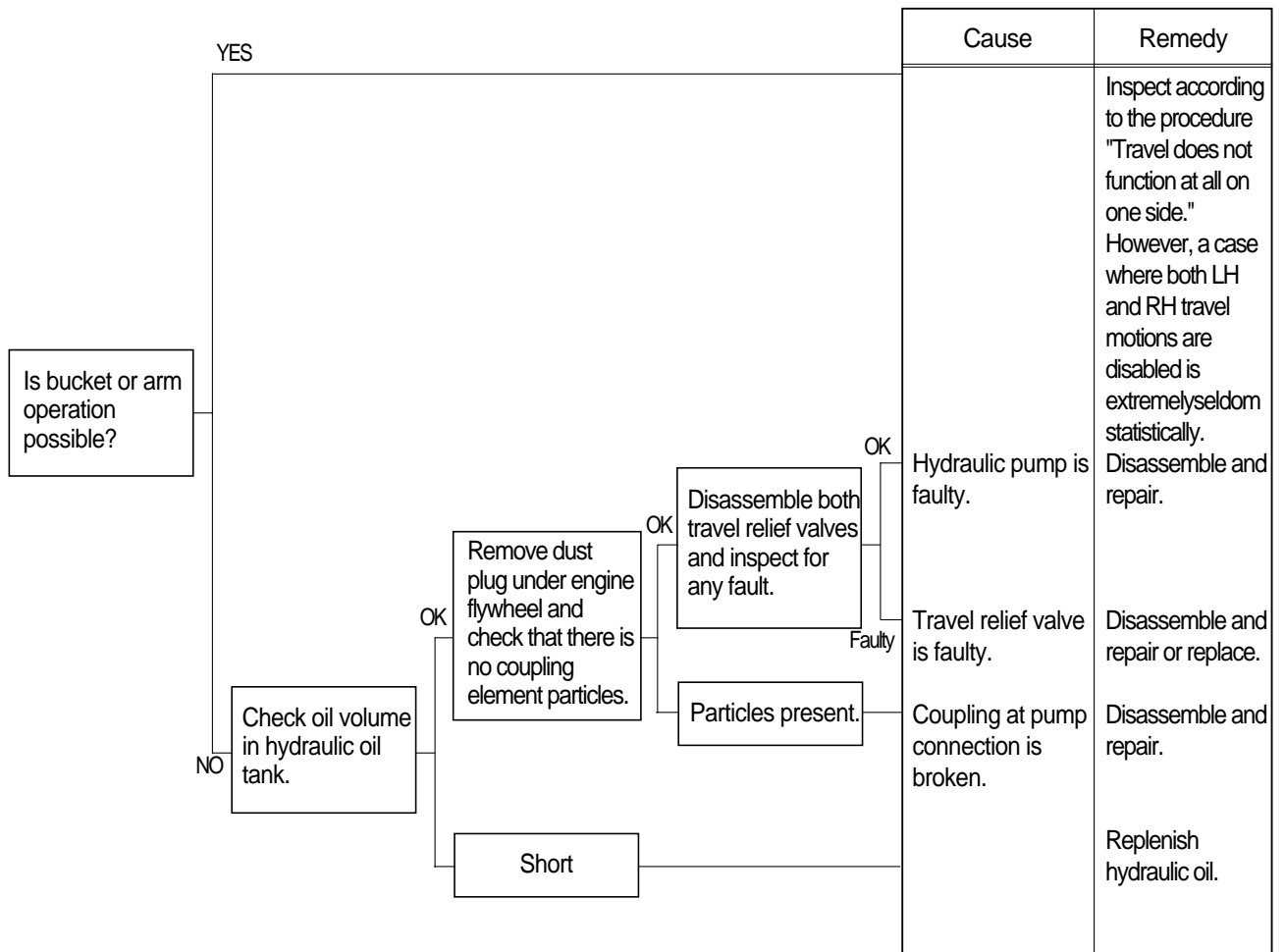

5) TRAVEL ACTION IS POWERLESS(Travel only)

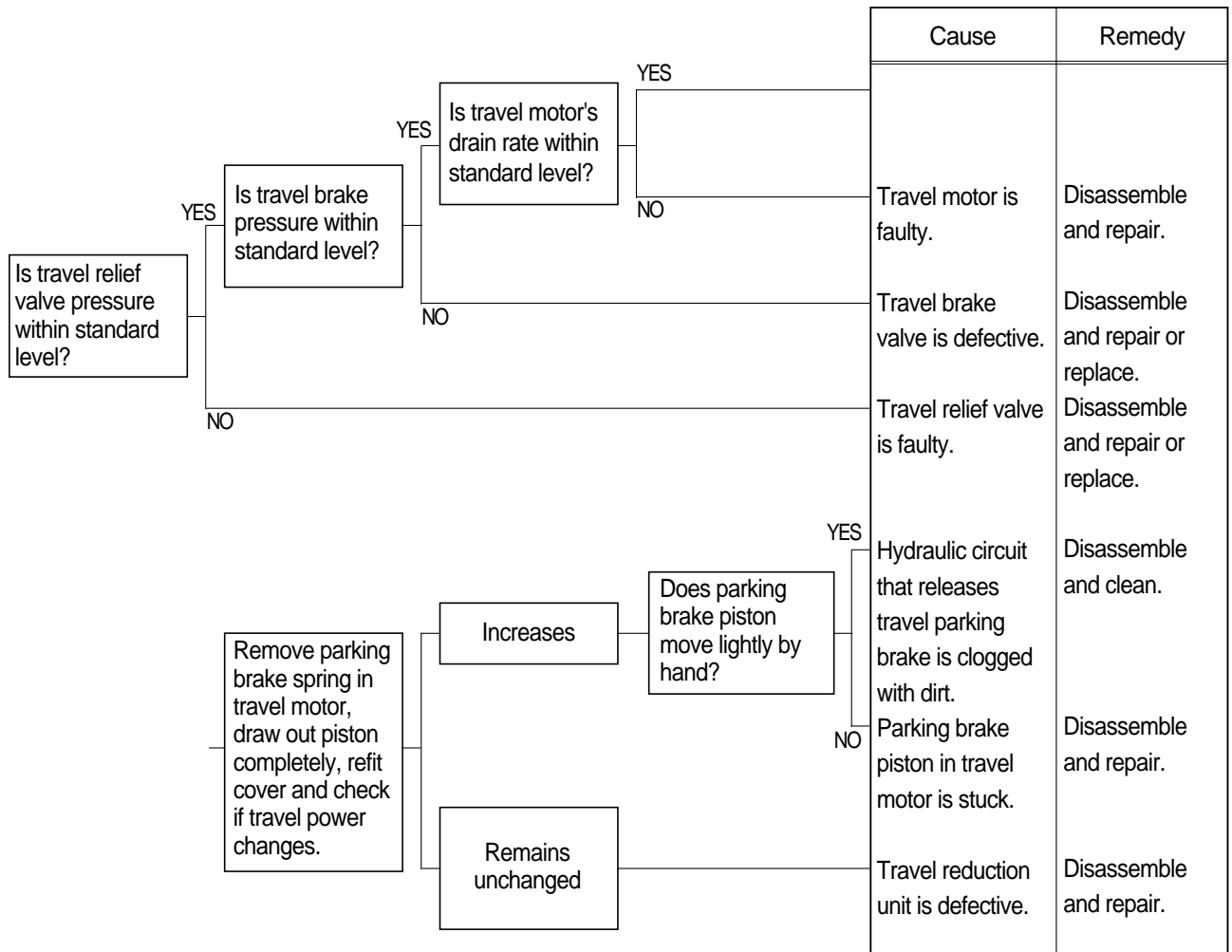

6) MACHINE RUNS RECKLESSLY ON A SLOPE



7) MACHINE MAKES A CURVED TRAVEL OR DOES NOT TRAVEL AT ALL WHEN TRAVEL AND ATTACHMENT OPERATIONS ARE EXECUTED AT THE SAME TIME

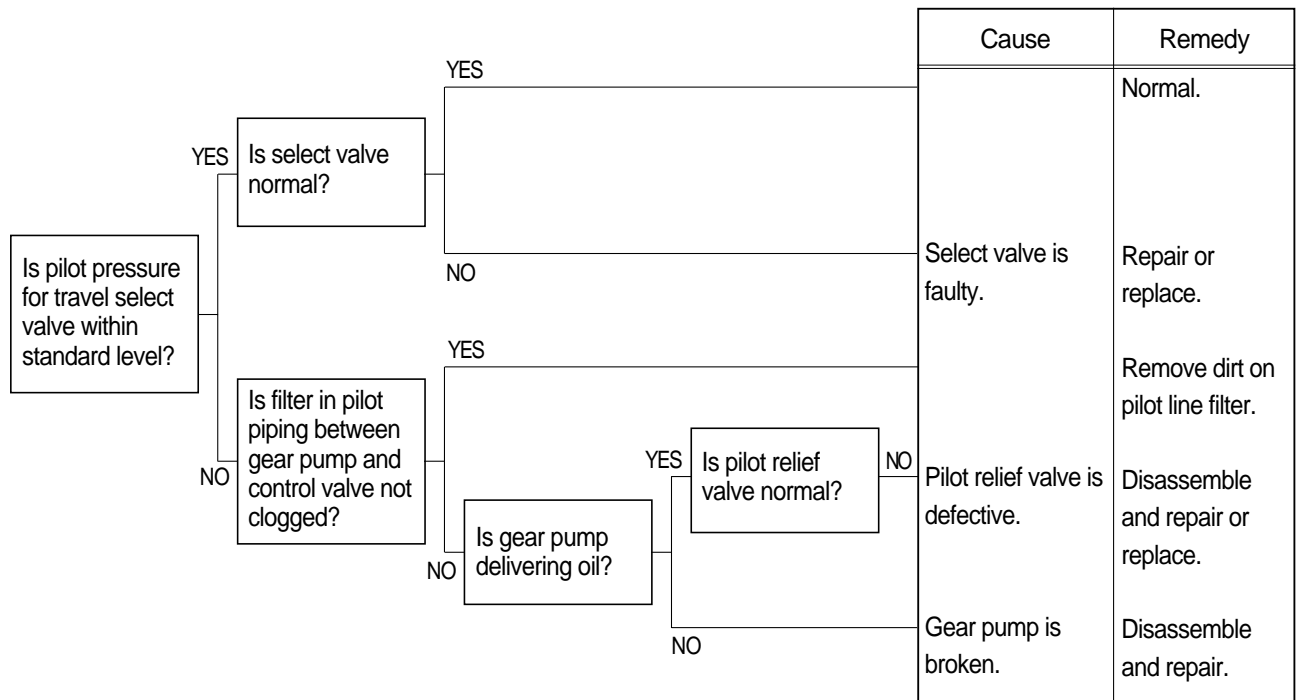

6. ATTACHMENT SYSTEM

1) BOOM OR ARM ACTION IS IMPOSSIBLE AT ALL

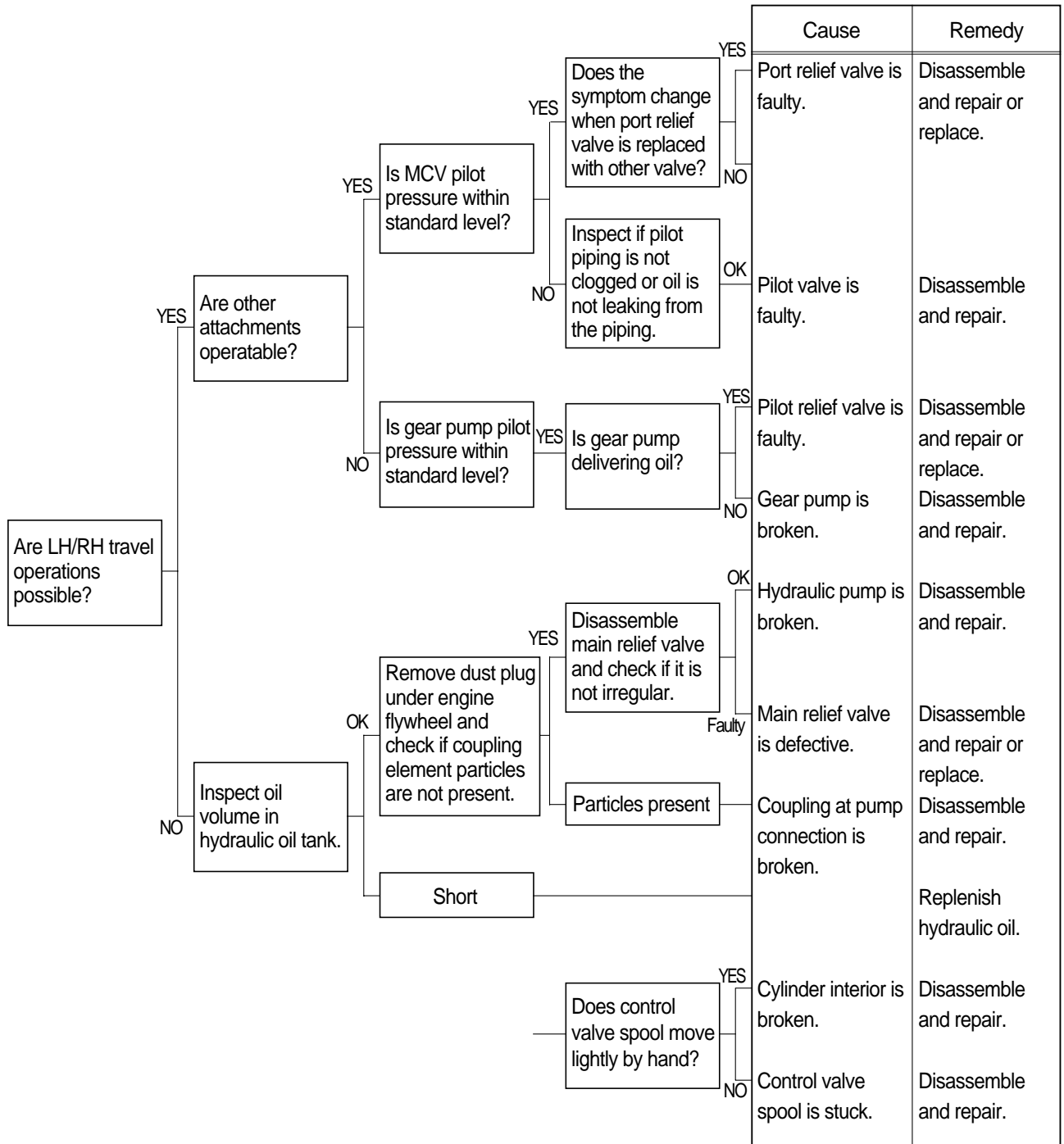

2) BOOM, ARM OR BUCKET SPEED IS LOW

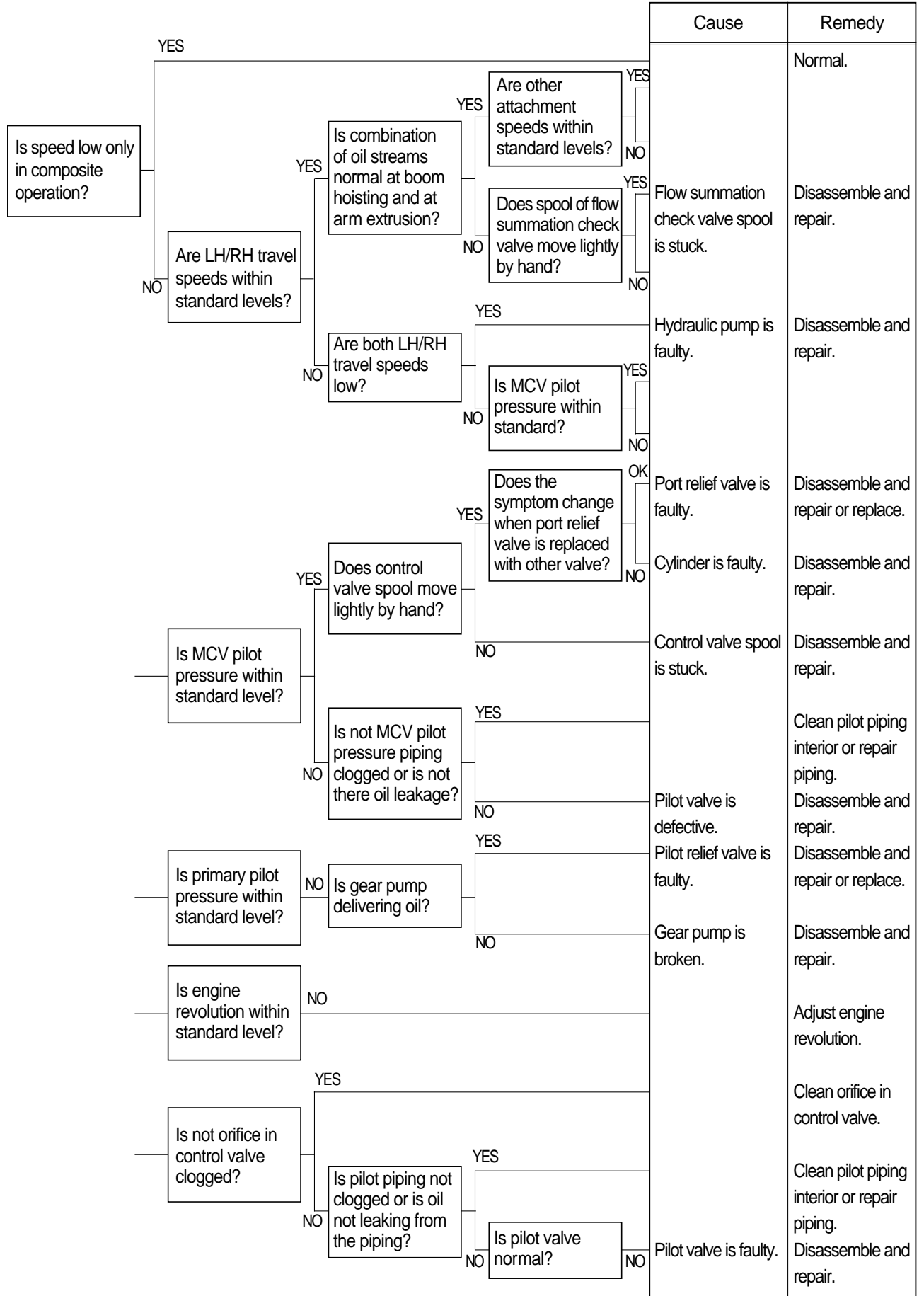

3) BOOM, ARM OR BUCKET CYLINDER EXTENDS OR CONTRACTS ITSELF AND ATTACHMENT FALLS

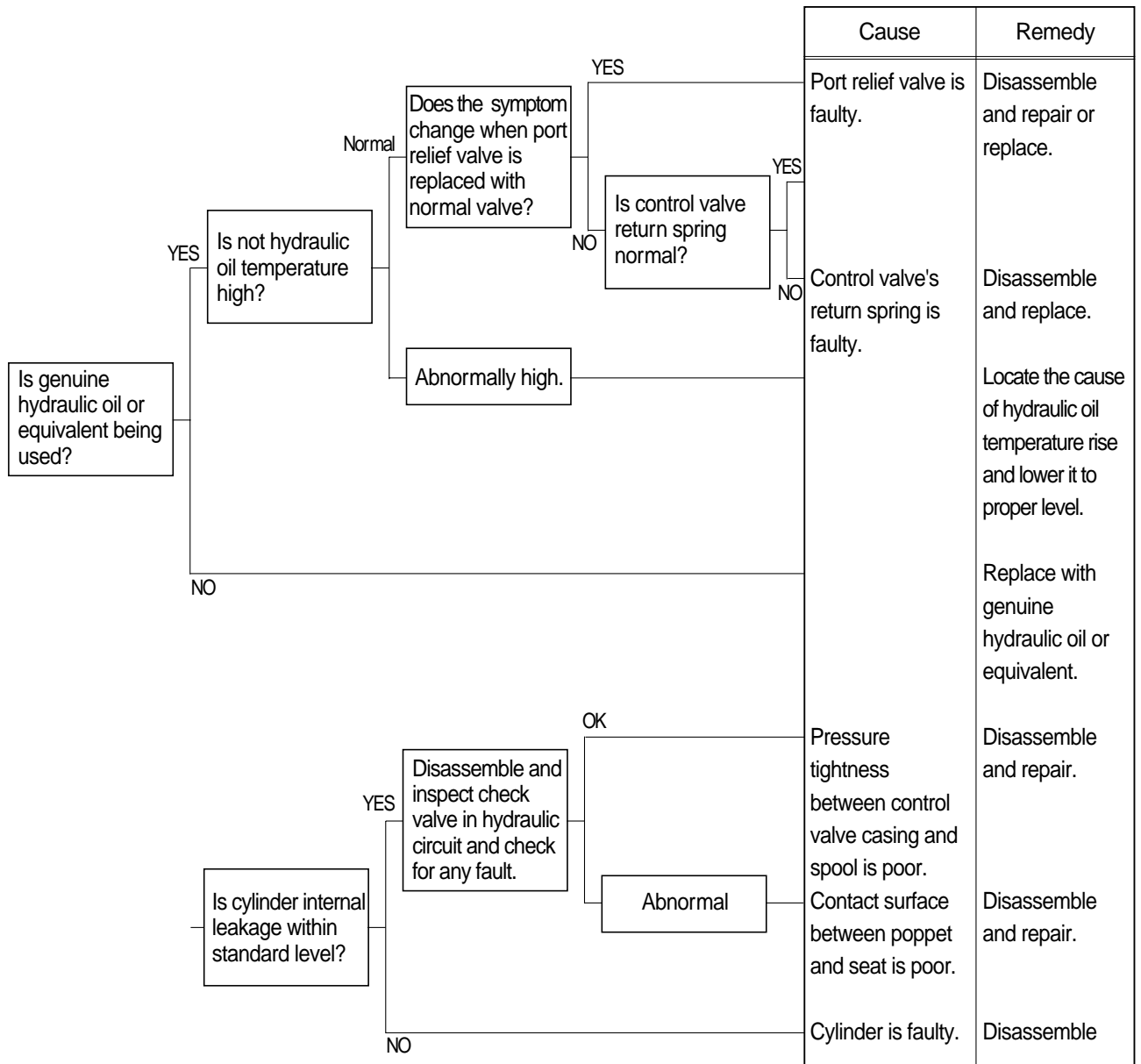

4) BOOM, ARM OR BUCKET POWER IS WEAK

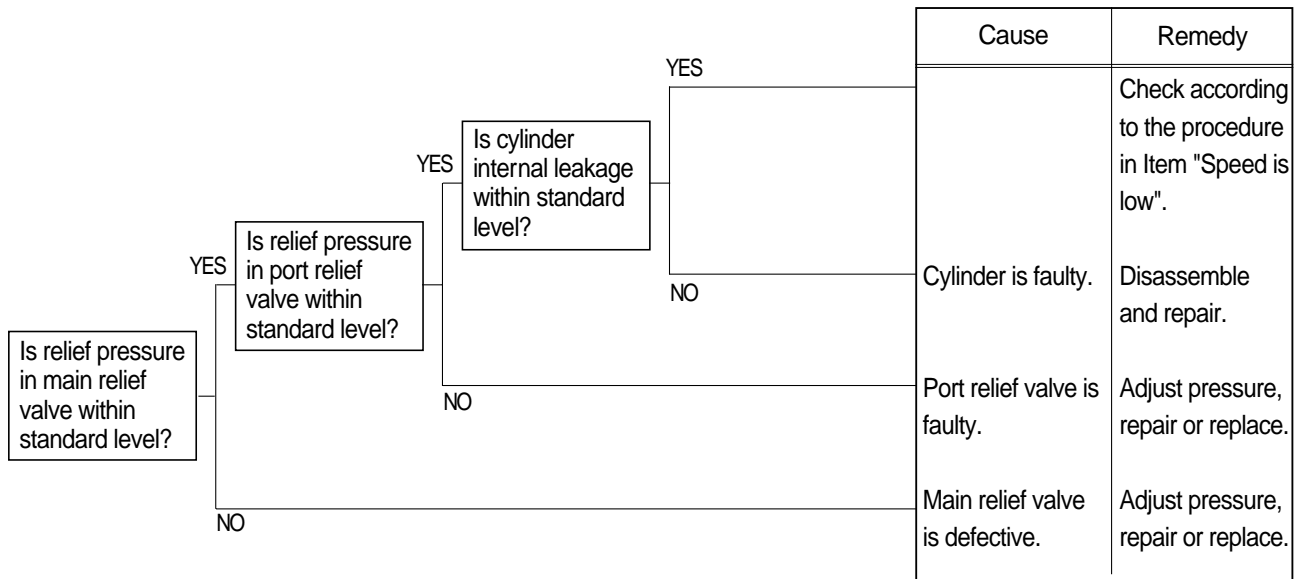

5) ONLY BUCKET OPERATION IS TOTALLY IMPOSSIBLE

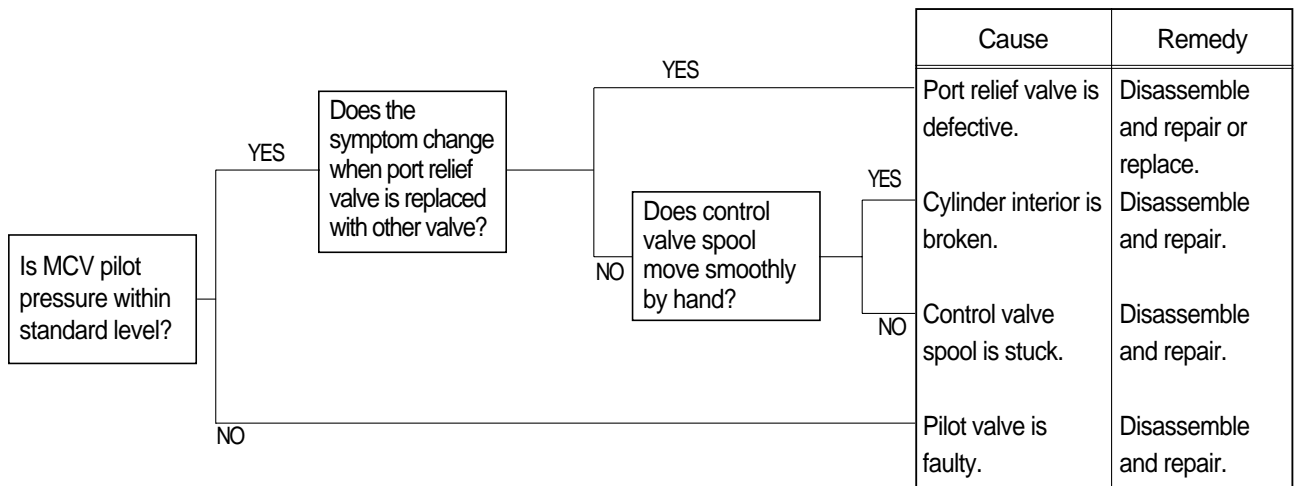

6) BOOM MAKES A SQUEAKING NOISE WHEN BOOM IS OPERATED

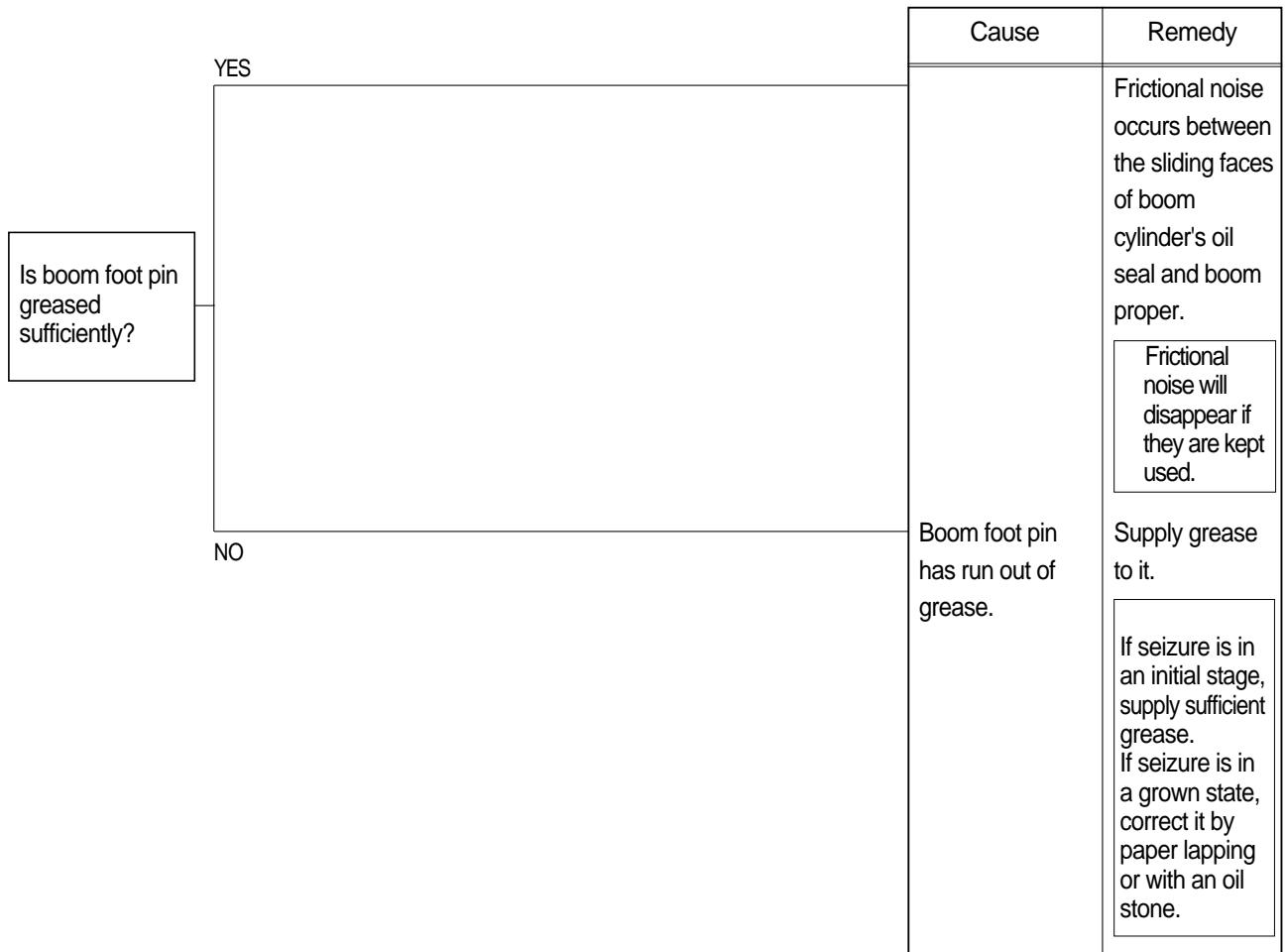

HOW TO CHECK INTERNAL BOOM CYLINDER LEAKAGE

1. Lower the bucket teeth to the ground with bucket cylinder fully retracted and arm cylinder rod retracted almost in full.

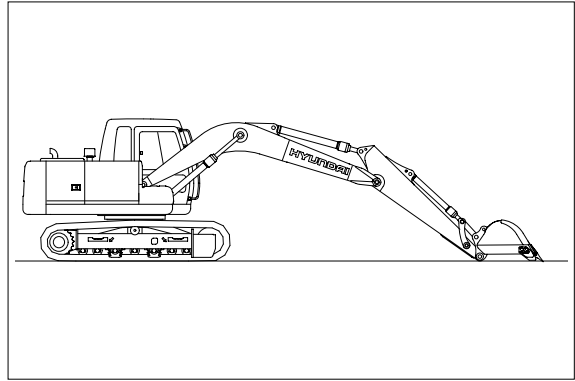

2. Disconnect hose(A) from rod side of boom cylinder and drain oil from cylinders and hose. (Put cups on piping and hose ends)

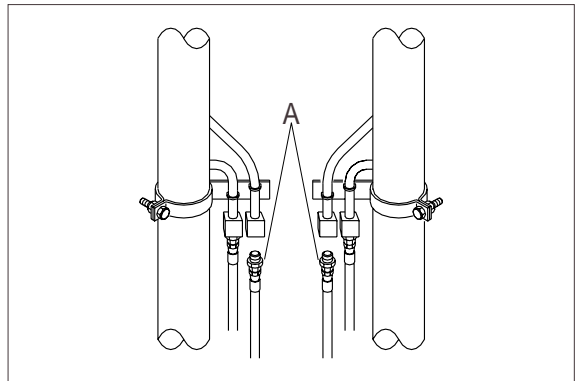

3. Raise bucket OFF the ground by retracting the arm cylinder rod.

If oil leaks from piping side and boom cylinder rod is retracted there is an internal leak in the cylinder.

If no oil leaks from piping side and boom cylinder rod is retracted, there is an internal leak in the control valve.

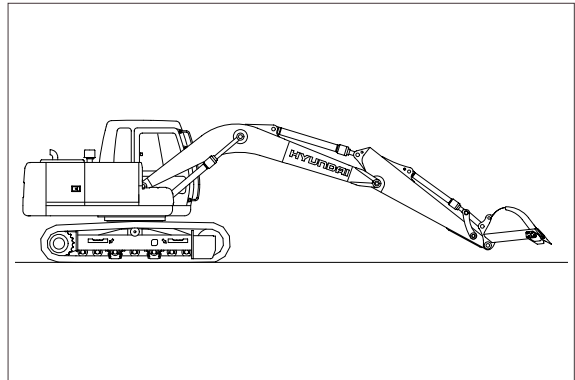

GROUP 3 ELECTRICAL SYSTEM

1. WHEN STARTING SWITCH IS TURNED ON, MONITOR PANEL DISPLAY DOES NOT APPEAR

- Before disconnecting the connector, always turn the starting switch OFF.
- Before carrying out below procedure, check all the related connectors are properly inserted and short of fuse No.7.
- After checking, insert the disconnected connectors again immediately unless otherwise specified.

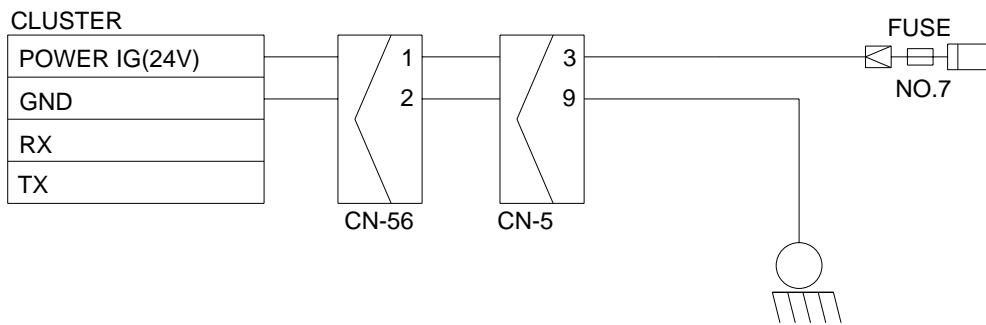
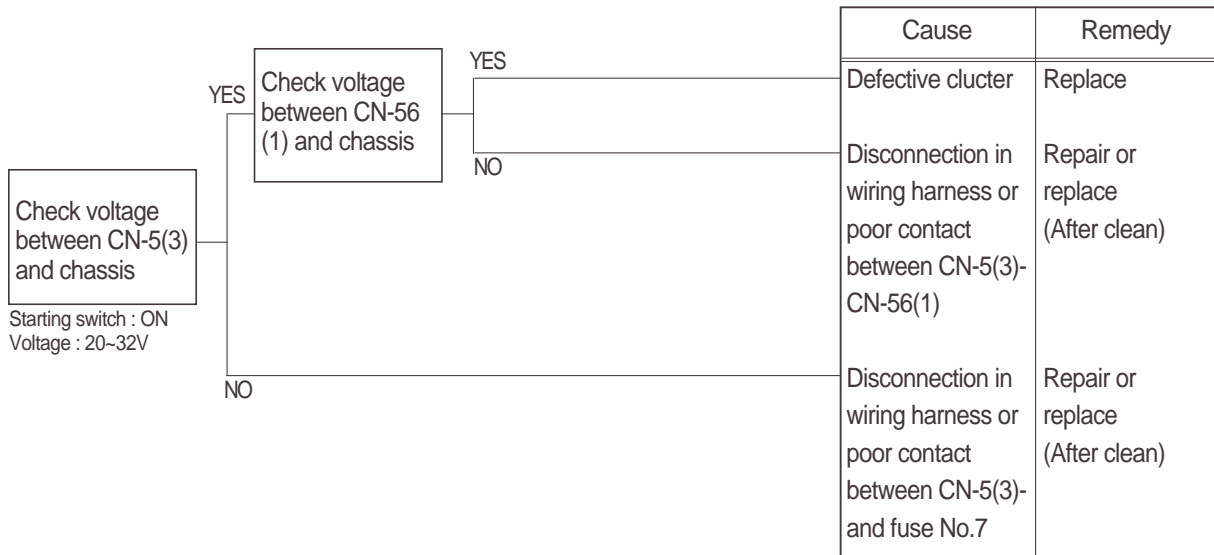

Check voltage

YES	20 ~ 30V
NO	0V

2. COMMUNICATION ERROR "Co : Err" FLASHES ON THE CLUSTER

- Before disconnecting the connector, always turn the starting switch OFF.
- Before carrying out below procedure, check all the related connectors are properly inserted.
- After checking, insert the disconnected connectors again immediately unless otherwise specified.

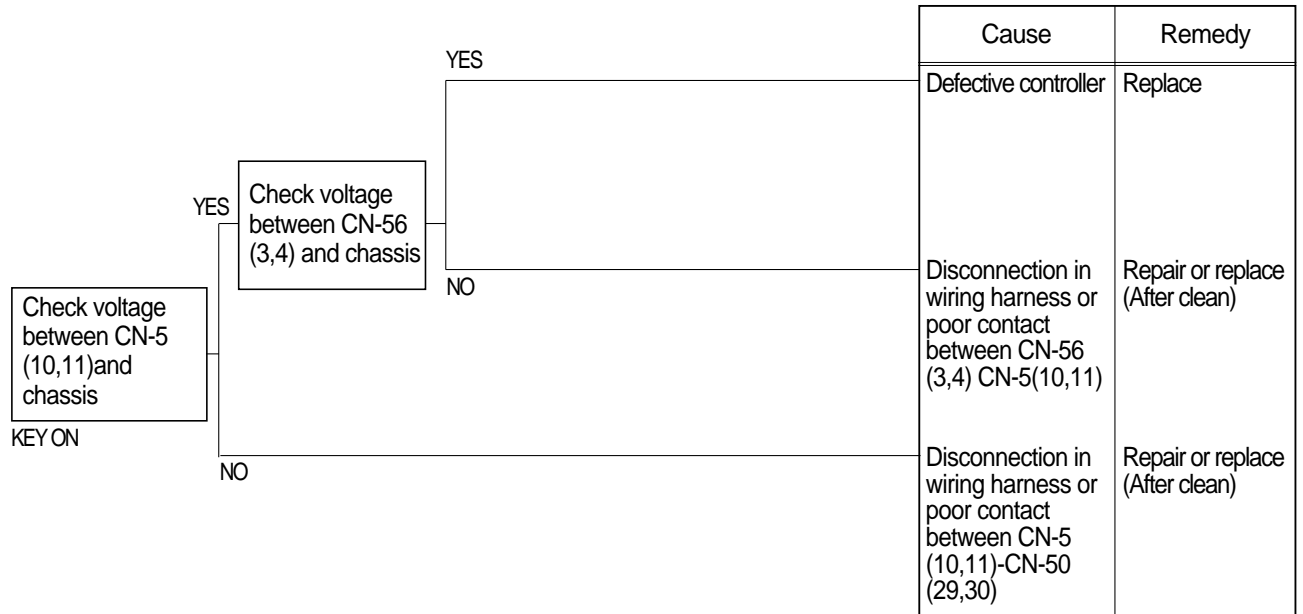

Check voltage

YES	*4V	*12V
NO	0V	0V

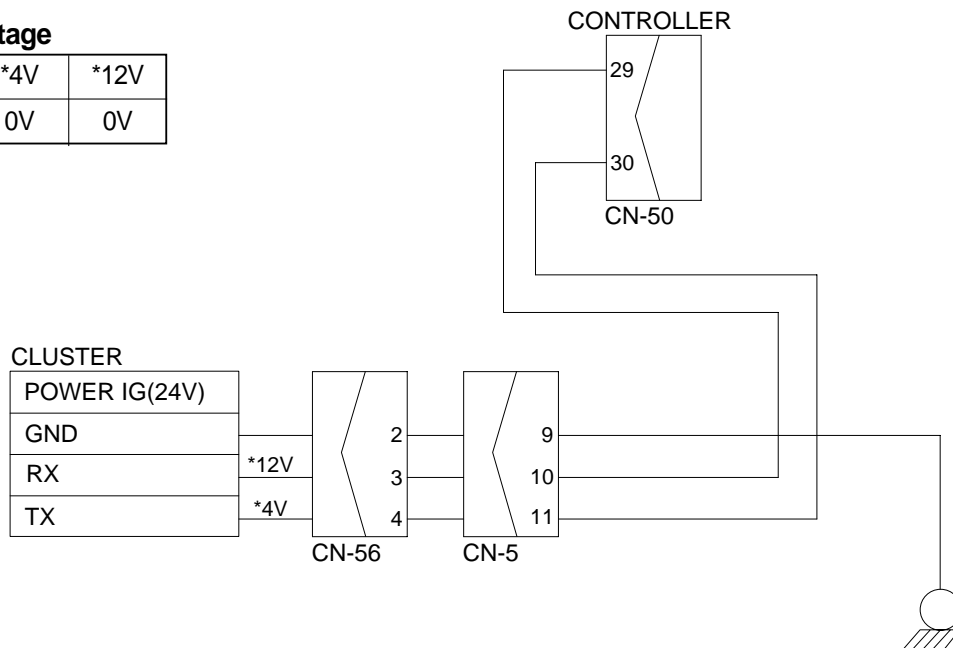

3. BATTERY CHARGING WARNING LAMP LIGHTS UP (Starting switch : ON)

- Before disconnecting the connector, always turn the starting switch OFF.
- Before carrying out below procedure, check all the related connectors are properly inserted.
- After checking, insert the disconnected connectors again immediately unless otherwise specified.

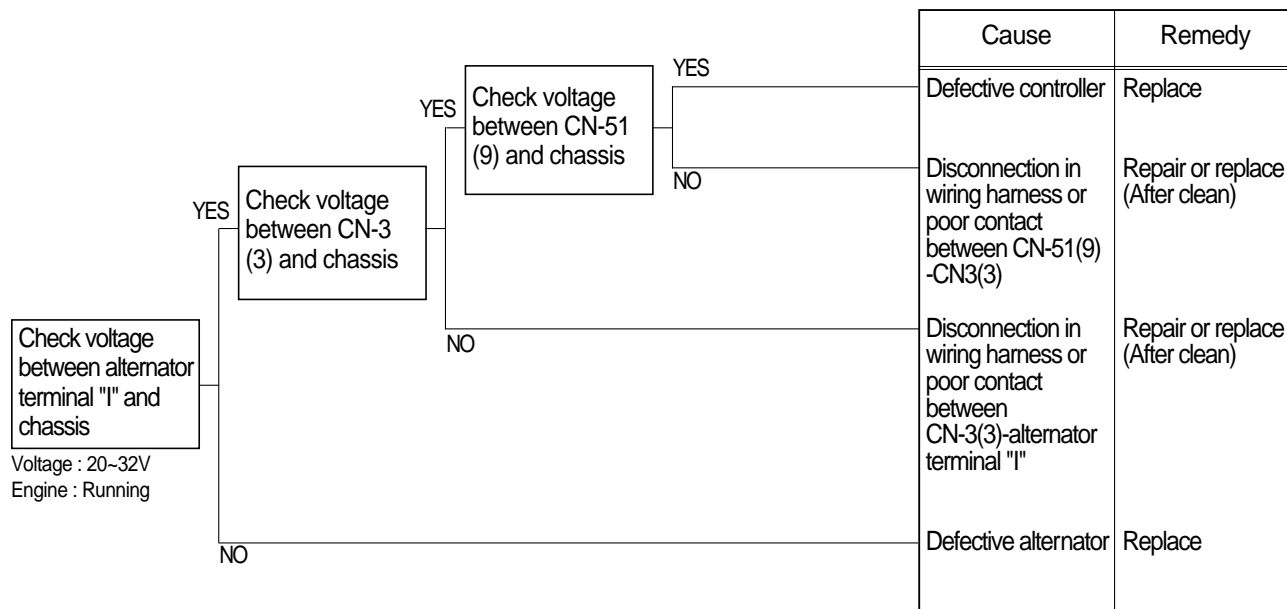

Check voltage

YES	20 ~ 32V
NO	0V

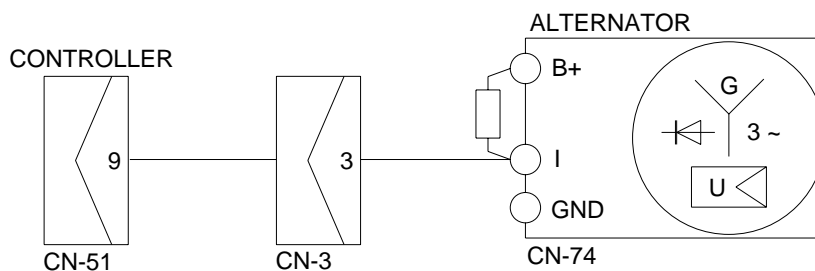

4. WHEN COOLANT OVERHEAT WARNING LAMP LIGHTS UP(Engine is started)

- Before disconnecting the connector, always turn the starting switch OFF.
- Before carrying out below procedure, check all the related connectors are properly inserted.
- After checking, insert the disconnected connectors again immediately unless otherwise specified.

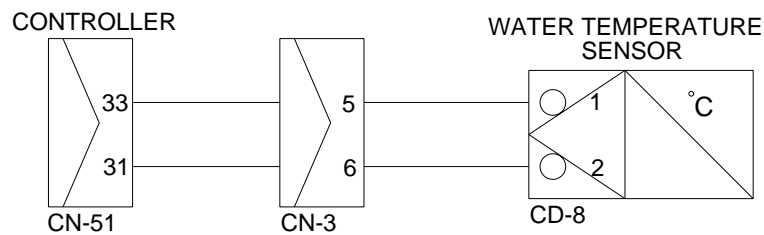
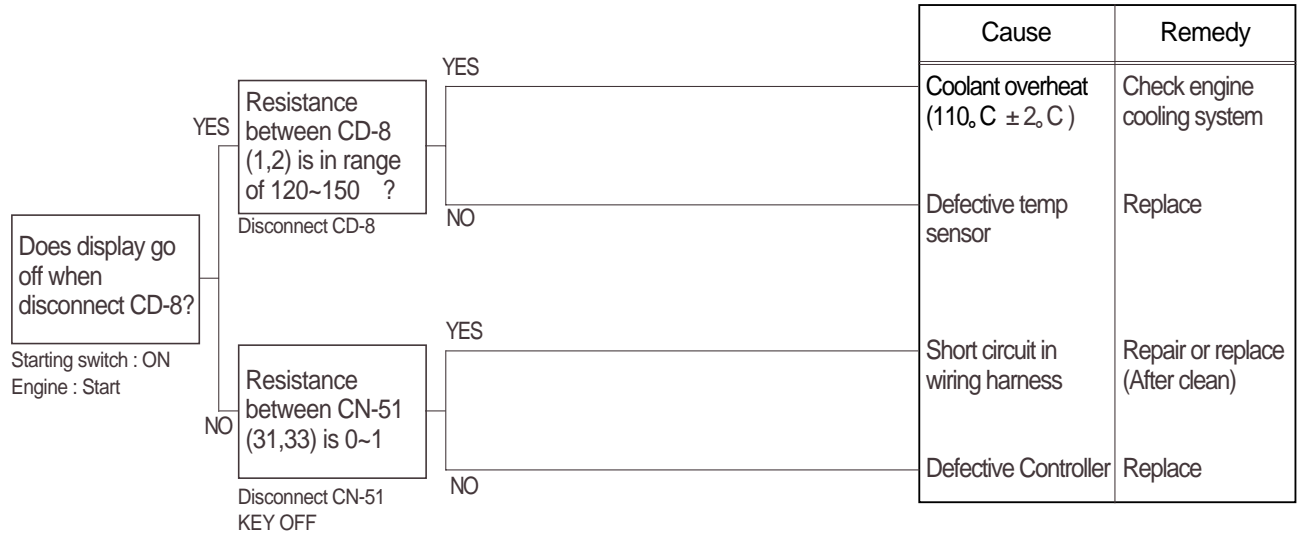

5. WHEN AIR CLEANER WARNING LAMP LIGHTS UP(Engine is started)

- Before disconnecting the connector, always turn the starting switch OFF.
- Before carrying out below procedure, check all the related connectors are properly inserted.
- After checking, insert the disconnected connectors again immediately unless otherwise specified.

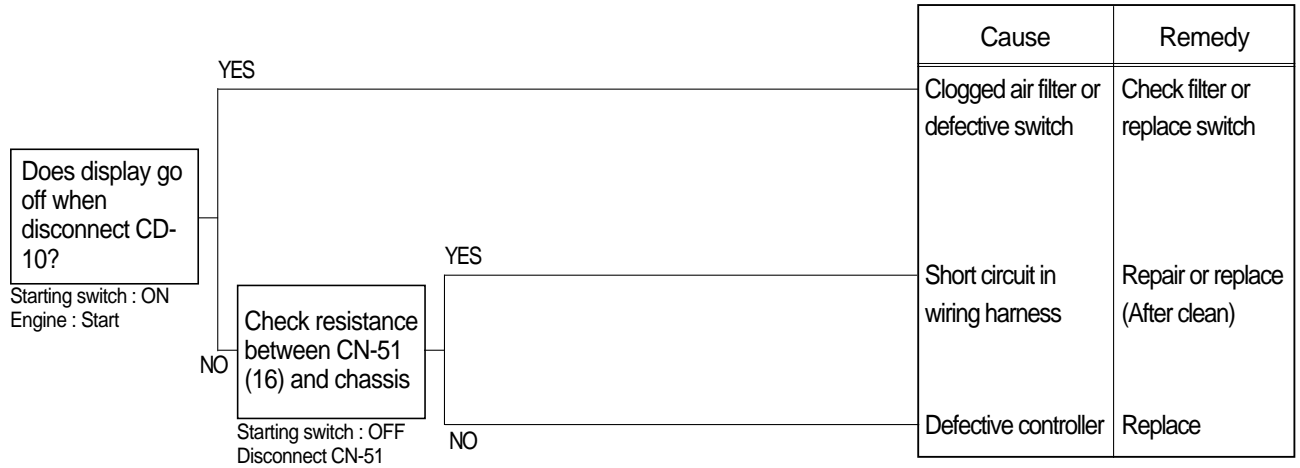

Check resistance

YES	MAX 1
NO	MIN 1M



6.  **WHEN ENGINE OIL PRESSURE WARNING LAMP LIGHTS UP**(Engine is started)

- Before disconnecting the connector, always turn the starting switch OFF.
- Before carrying out below procedure, check all the related connectors are properly inserted.
- After checking, insert the disconnected connectors again immediately unless otherwise specified.

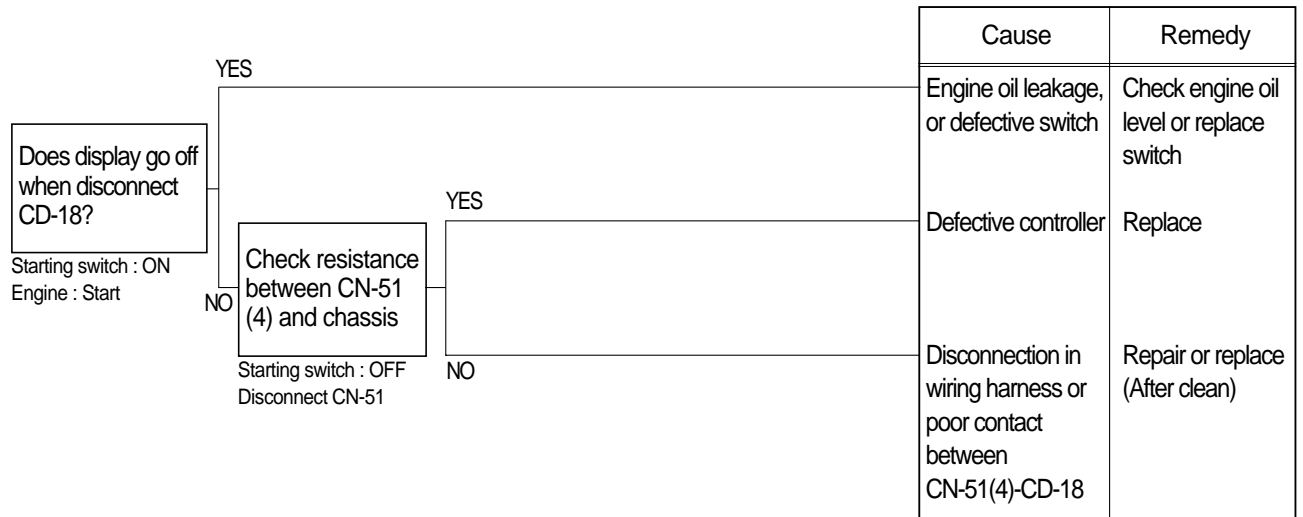

Check resistance

YES	MAX 1
NO	MIN 1M

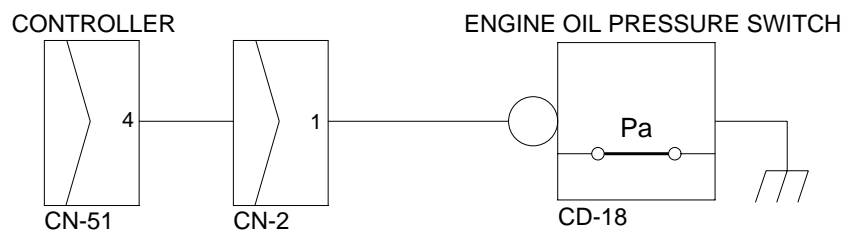

7. WHEN HYDRAULIC OIL TEMPERATURE WARNING LAMP LIGHTS UP(Engine is started)

- Before disconnecting the connector, always turn the starting switch OFF.
- Before carrying out below procedure, check all the related connectors are properly inserted.
- After checking, insert the disconnected connectors again immediately unless otherwise specified.

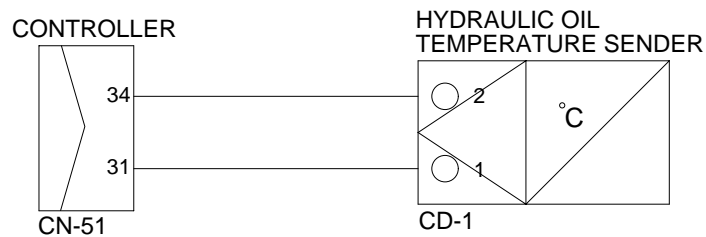
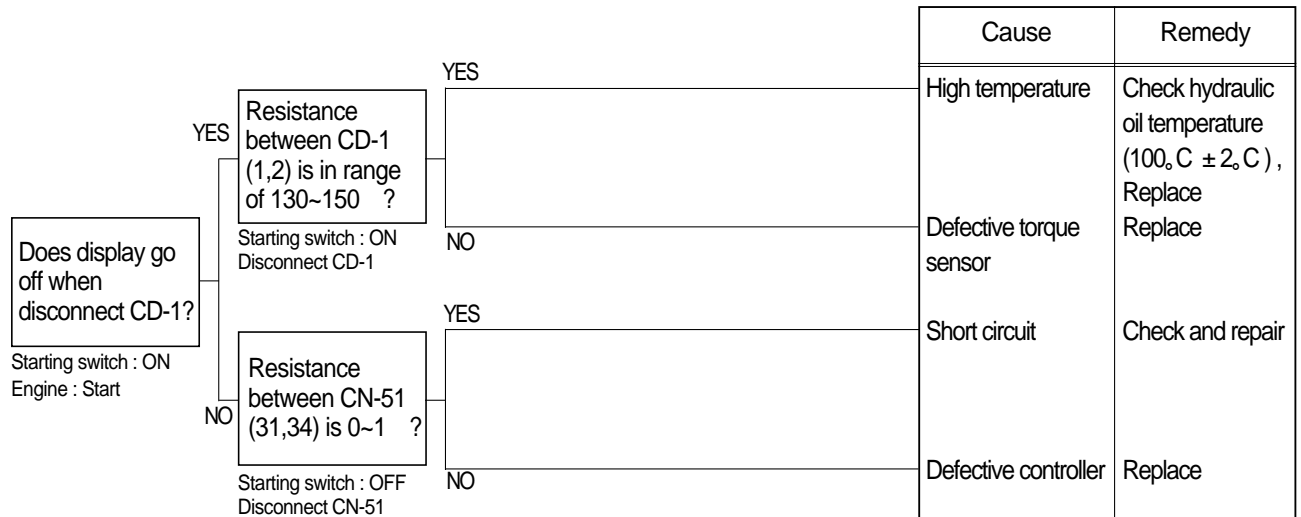

8. WHEN COOLANT LEVEL WARNING LAMP LIGHTS UP(Engine is started)

- Before disconnecting the connector, always turn the starting switch OFF.
- Before carrying out below procedure, check all the related connectors are properly inserted.
- After checking, insert the disconnected connectors again immediately unless otherwise specified.

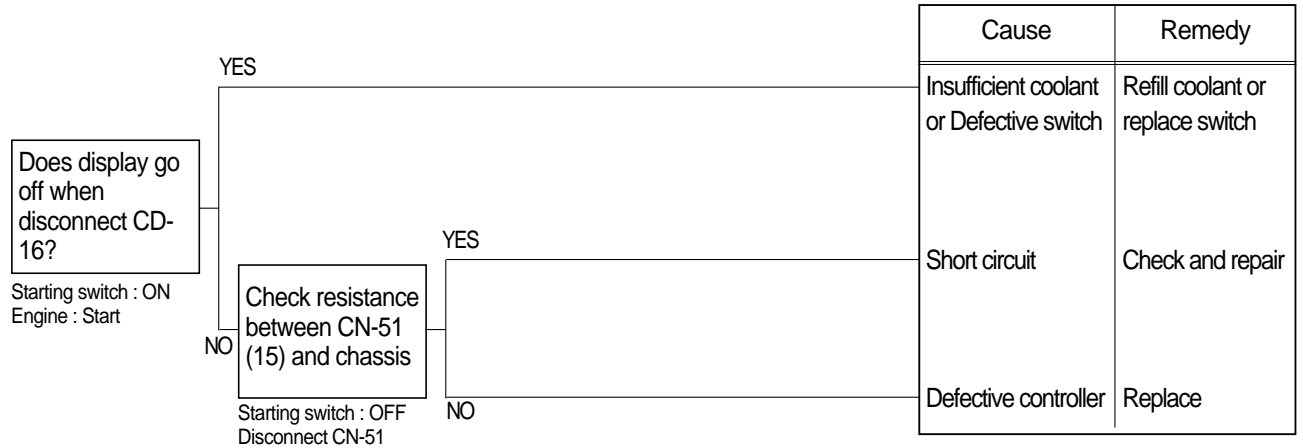

Check resistance

YES	MAX 1
NO	MIN 1M

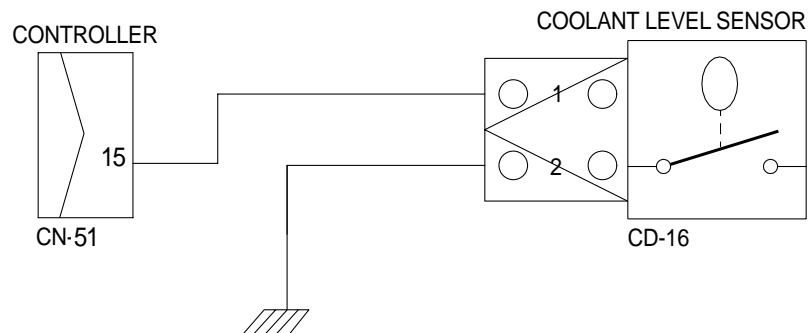

9. WHEN COOLANT TEMPERATURE GAUGE DOES NOT OPERATE

- Before disconnecting the connector, always turn the starting switch OFF.
- Before carrying out below procedure, check all the related connectors are properly inserted.
- After checking, insert the disconnected connectors again immediately unless otherwise specified.

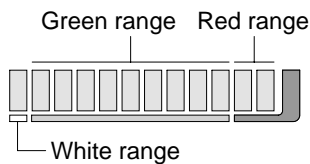
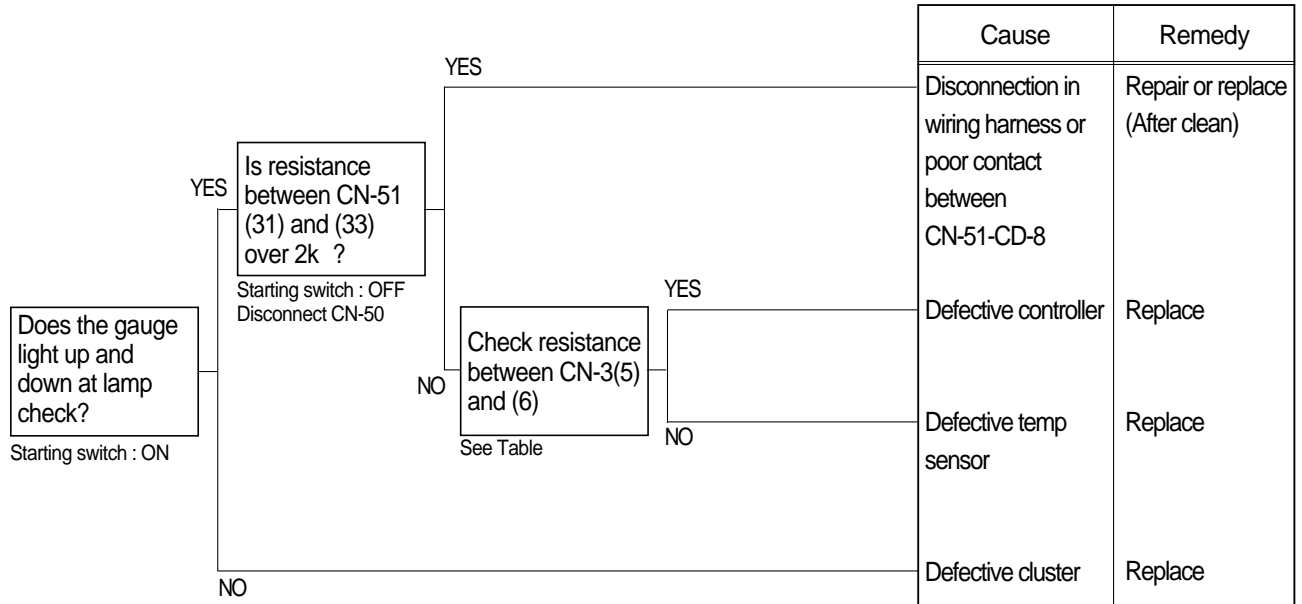

Check Table

Temperature Item	White range (~29°C)	Green range (30~105°C)	Red range (105°C ~)
Unit Resistance()	1646~	1645~158	~139
Tolerance(%)	± 20	± 20	± 20

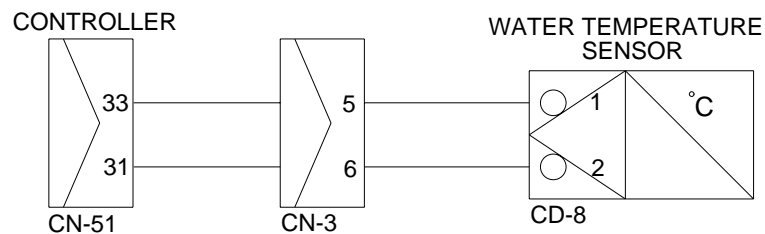

10. WHEN FUEL GAUGE DOES NOT OPERATE(Check warning lamp ON/OFF)

- Before disconnecting the connector, always turn the starting switch OFF.
- Before carrying out below procedure, check all the related connectors are properly inserted.
- After checking, insert the disconnected connectors again immediately unless otherwise specified.

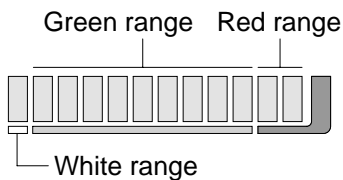
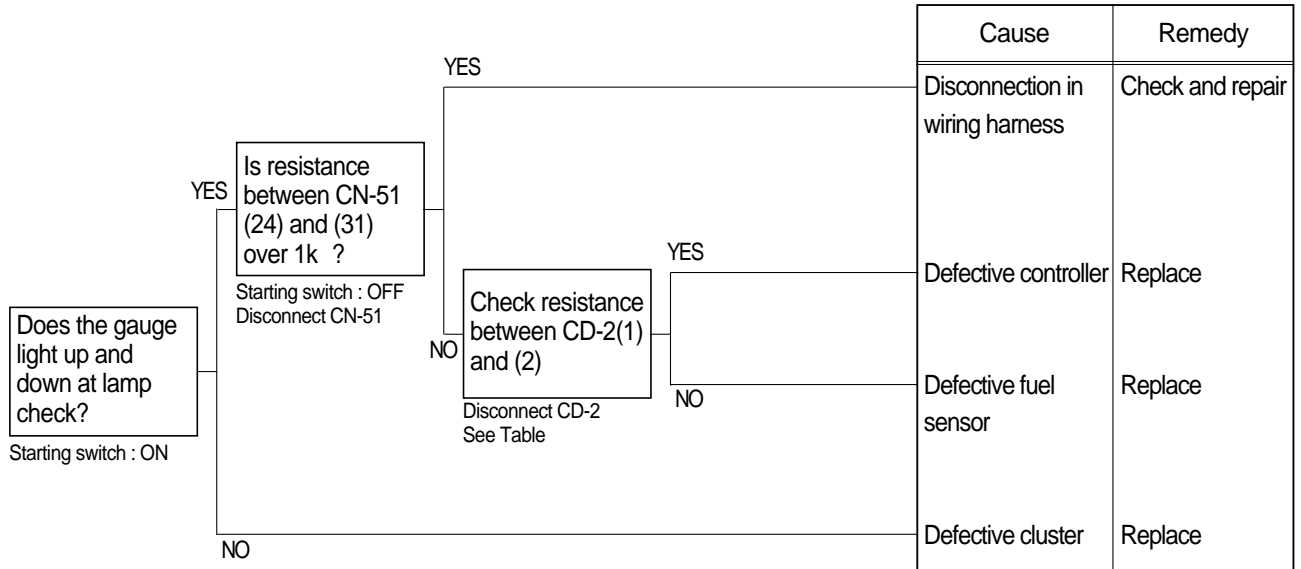

Check Table

Item \ Level	White range	Green range	Red range
Unit Resistance()	700~601	600~101	~100
Tolerance(%)	± 5	± 5	± 5

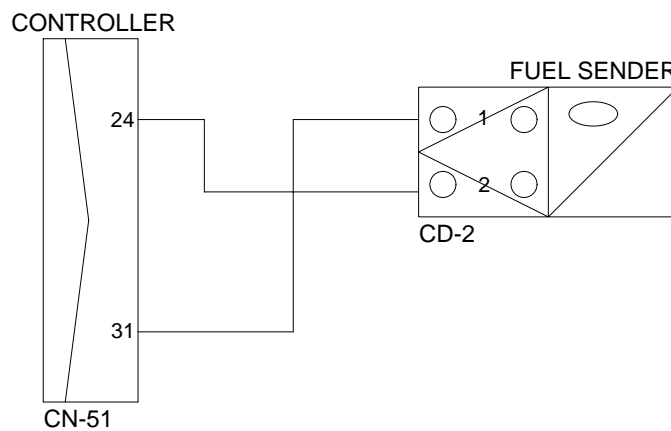

11. WHEN SAFETY SOLENOID DOES NOT OPERATE

- Before disconnecting the connector, always turn the starting switch OFF.
- Before carrying out below procedure, check all the related connectors are properly inserted and short of fuse No.24.
- After checking, insert the disconnected connectors again immediately unless otherwise specified.

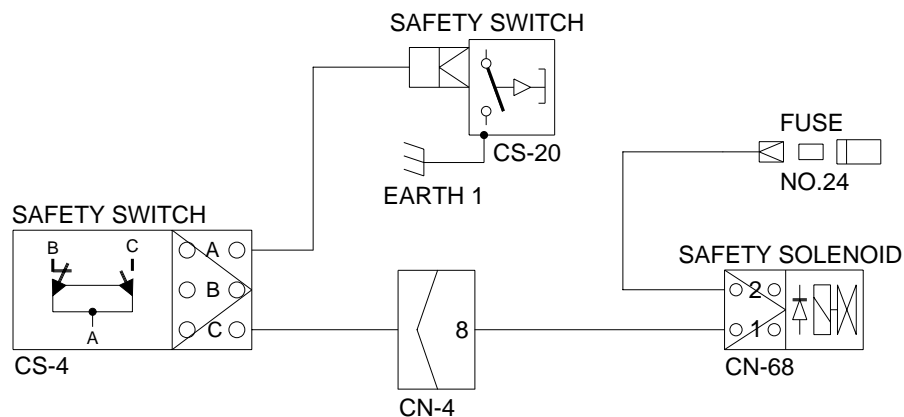
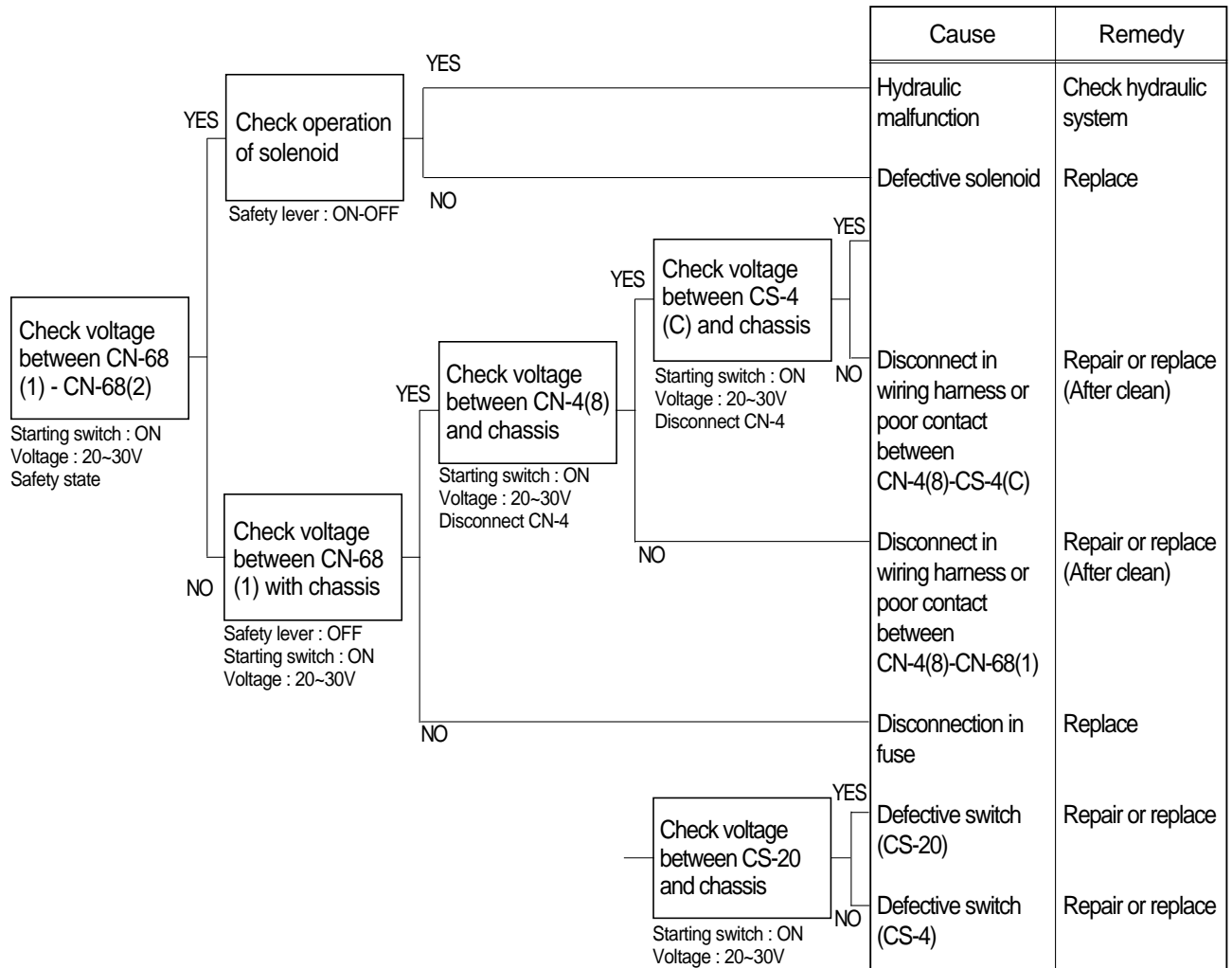

12. WHEN TRAVEL SPEED 1, 2 DOES NOT OPERATE

- Before disconnecting the connector, always turn the starting switch OFF.
- Before carrying out below procedure, check all the related connectors are properly inserted and short of fuse No.22 .
- After checking, insert the disconnected connectors again immediately unless otherwise specified.

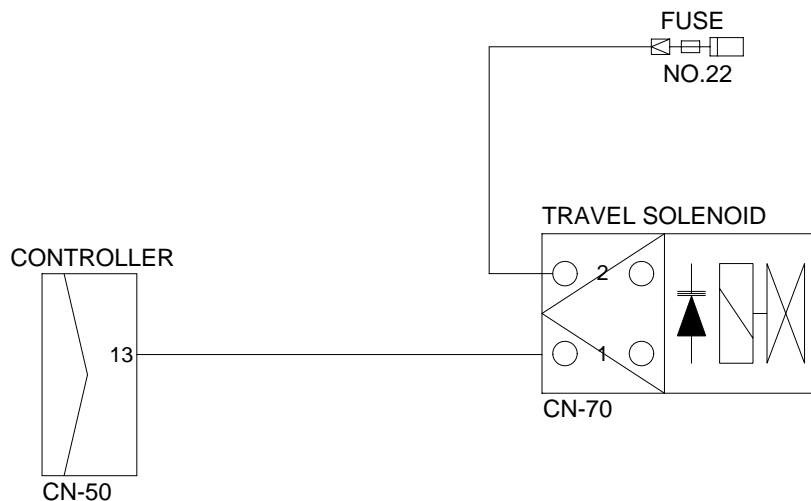
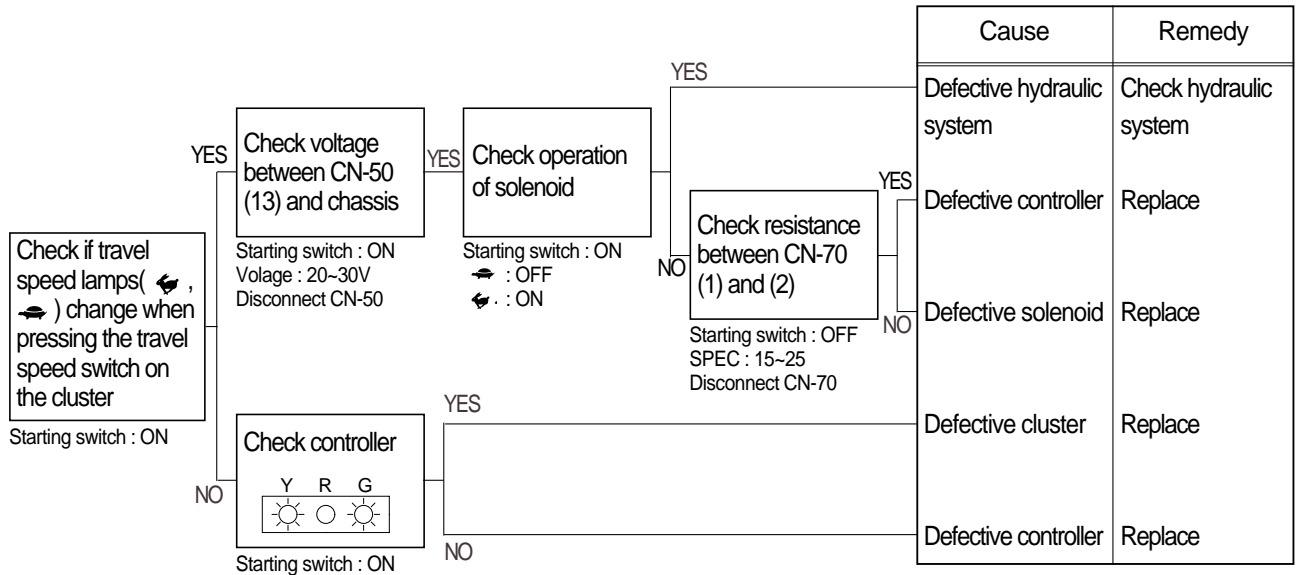

14. WHEN STARTING SWITCH ON DOES NOT OPERATE

- Before disconnecting the connector, always turn the starting switch OFF.
- Before carrying out below procedure, check all the related connectors are properly inserted and master switch ON.
- After checking, insert the disconnected connectors again immediately unless otherwise specified.

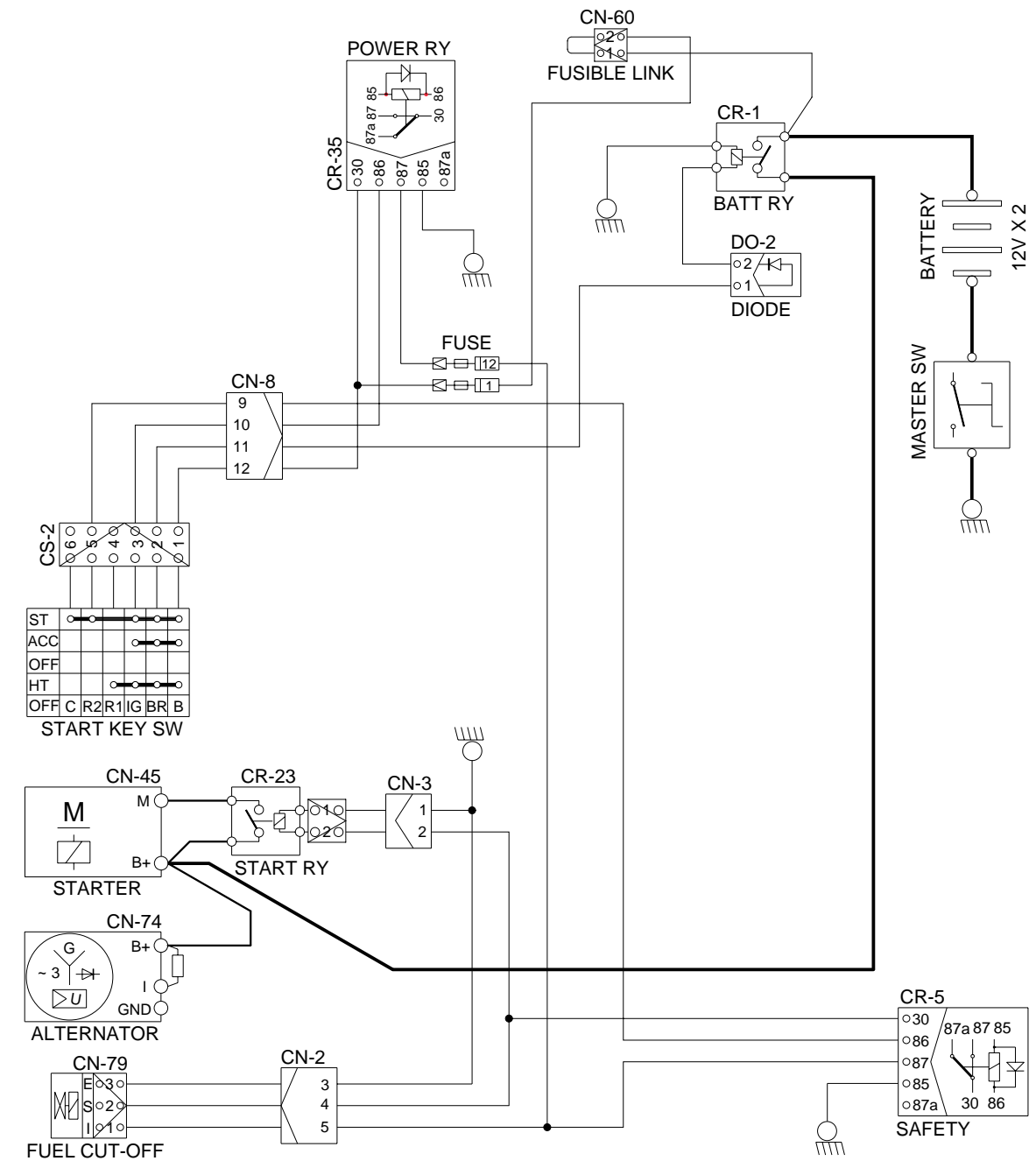
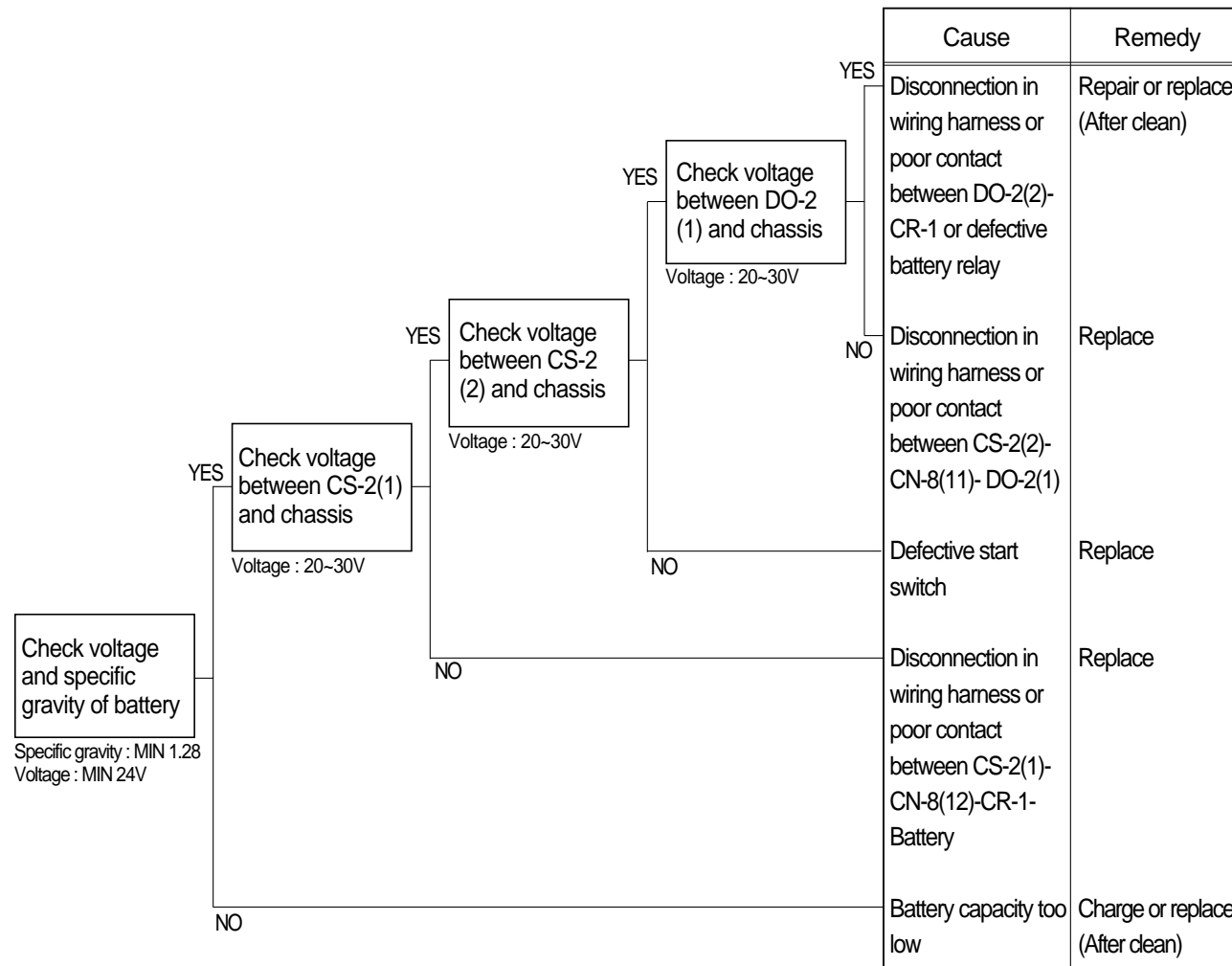

15. WHEN STARTING SWITCH IS TURNED ON, WIPER MOTOR DOES NOT OPERATE

- Before disconnecting the connector, always turn the starting switch OFF.
- Before carrying out below procedure, check all the related connectors are properly inserted and the fuse No.4,11 and 13 is not blown out.
- After checking, insert the disconnected connectors again immediately unless otherwise specified.

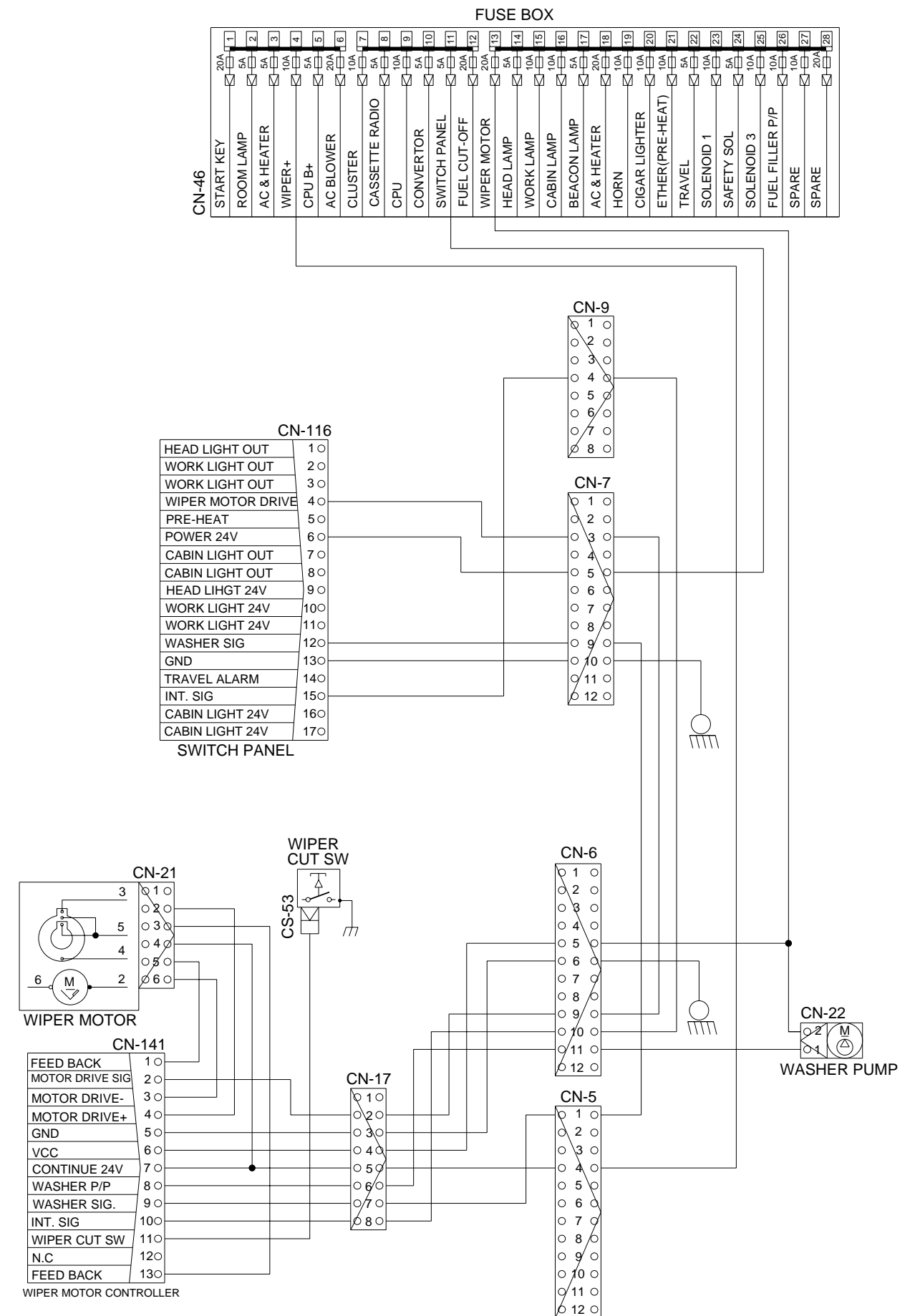
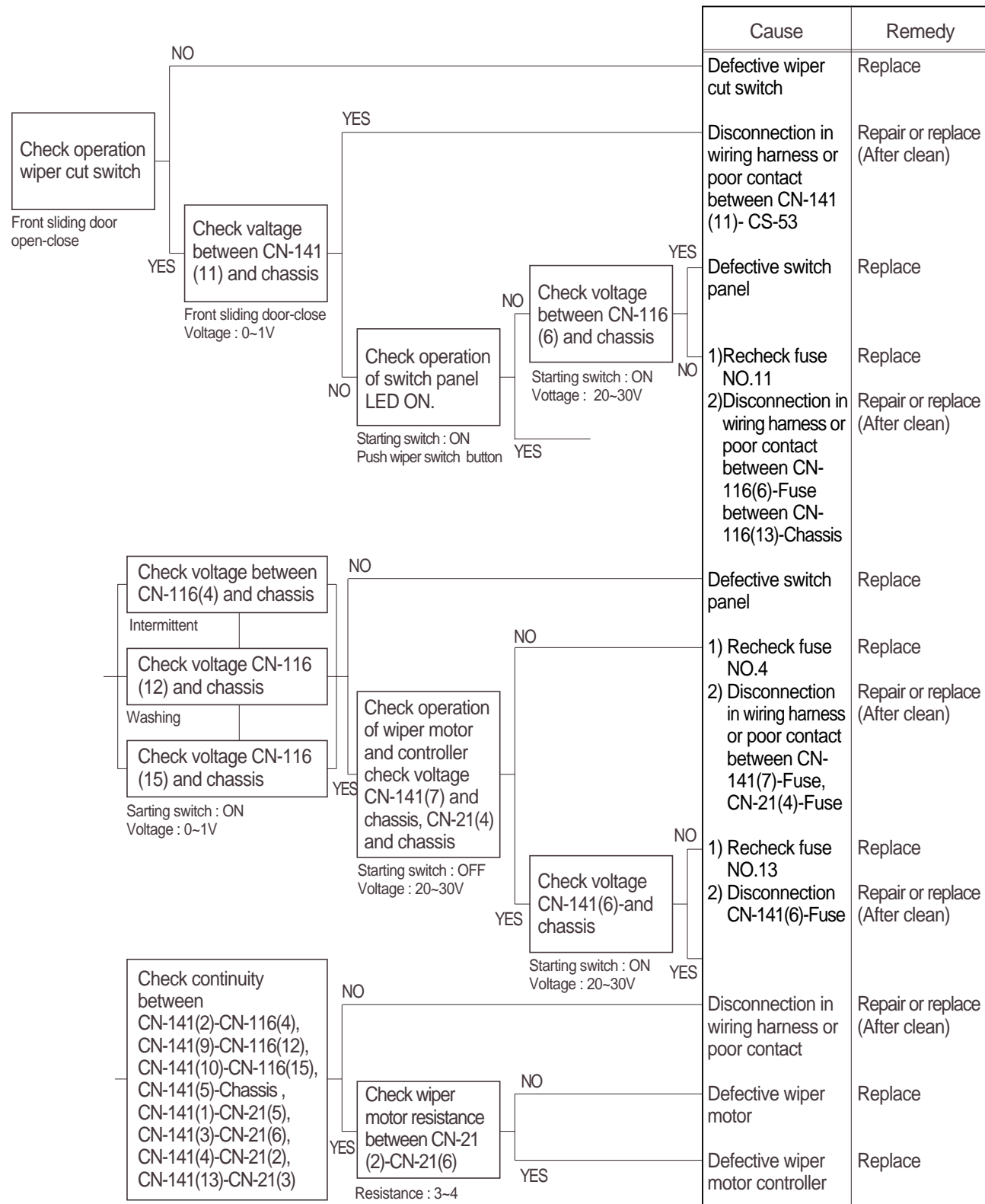

16. WHEN STARTING SWITCH IS TURNED ON, HEAD LAMP DOES NOT LIGHTS UP

- Before disconnecting the connector, always turn the starting switch OFF.
- Before carrying out below procedure, check all the related connectors are properly inserted and short of fuse No.14.
- After checking, insert the disconnected connectors again immediately unless otherwise specified.

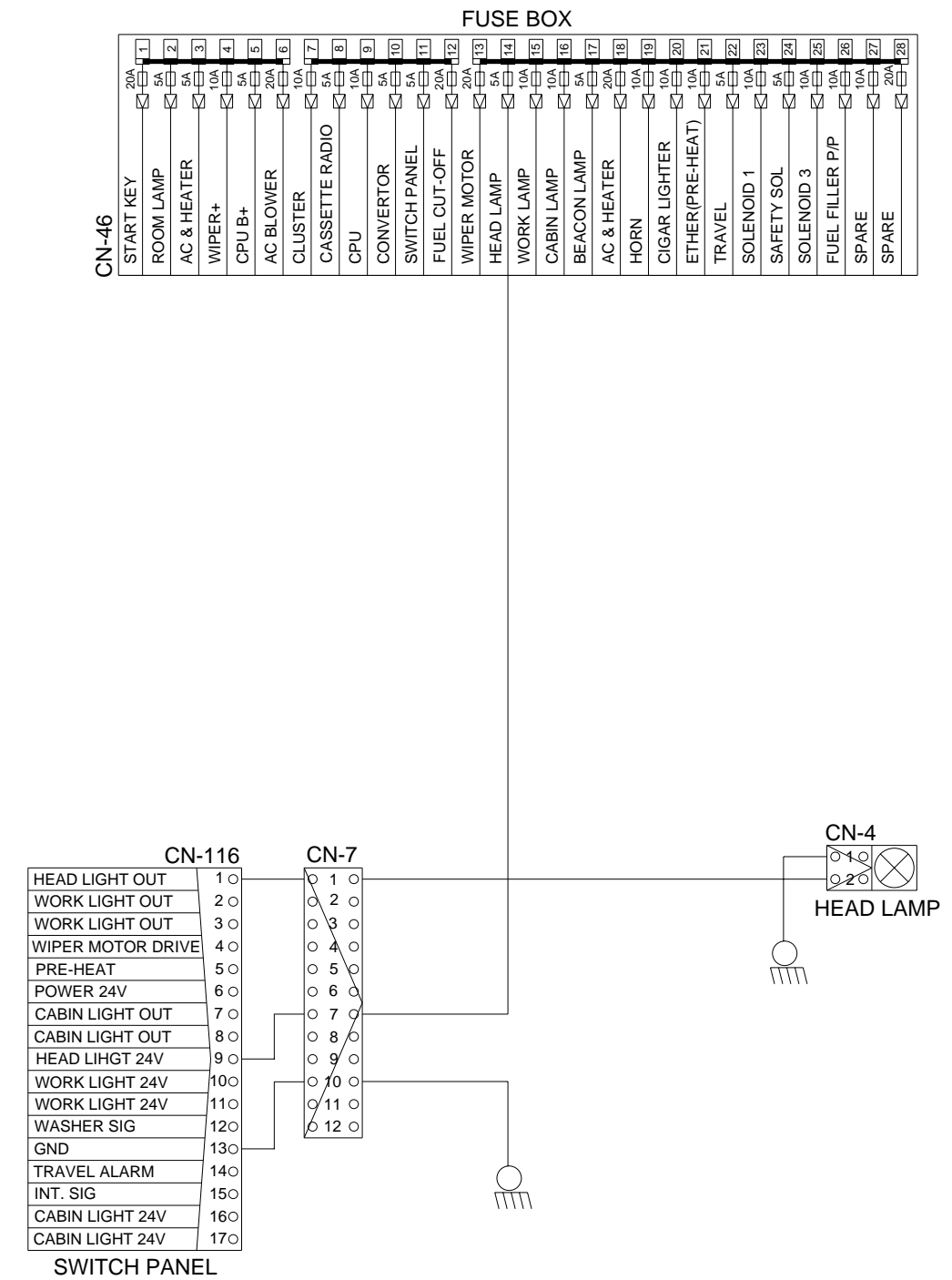
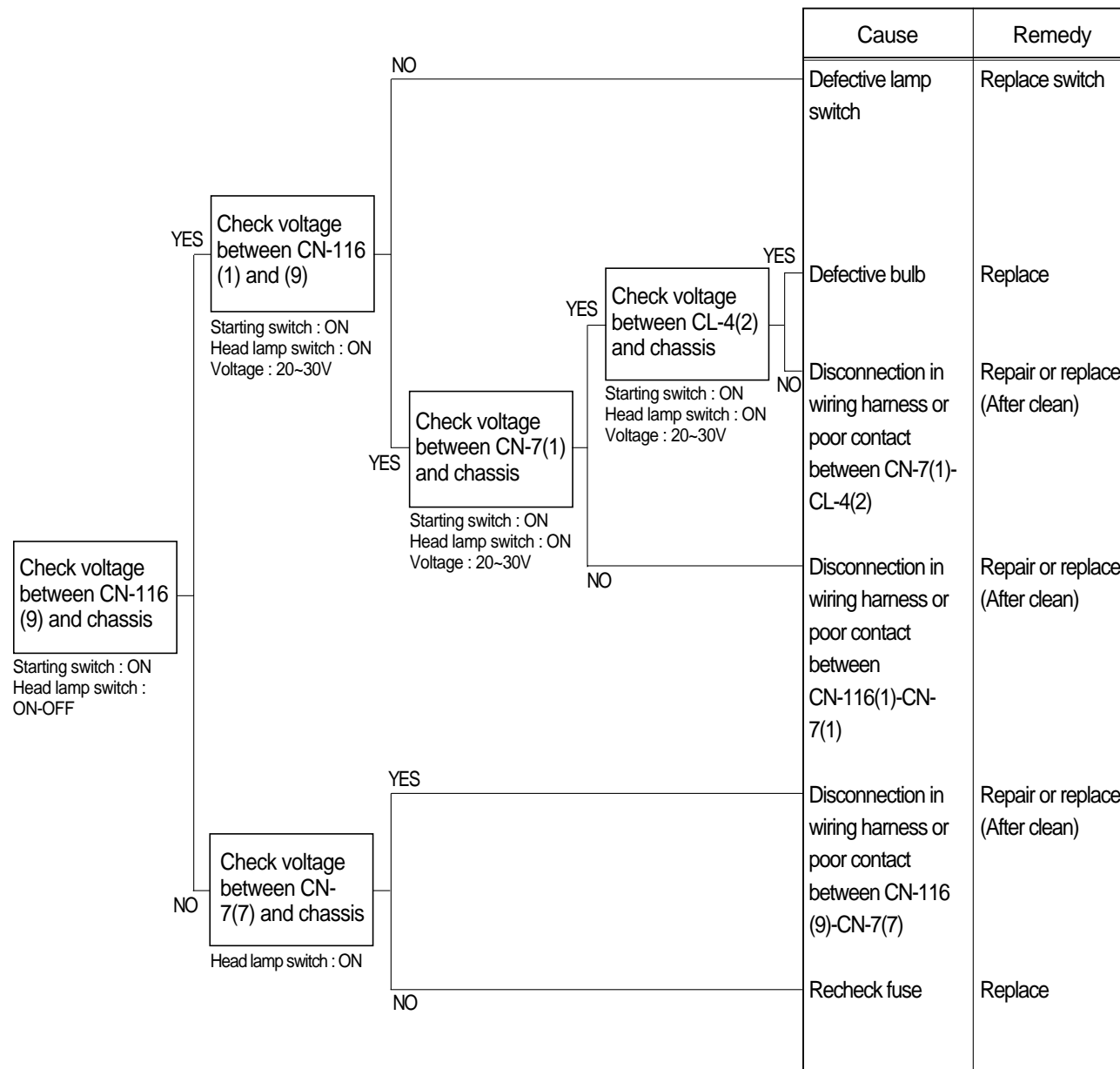

17. WHEN STARTING SWITCH IS TURNED ON, WORK LAMP DOES NOT LIGHTS UP

- Before disconnecting the connector, always turn the starting switch OFF.
- Before carrying out below procedure, check all the related connectors are properly inserted and short of fuse No.15.
- After checking, insert the disconnected connectors again immediately unless otherwise specified.

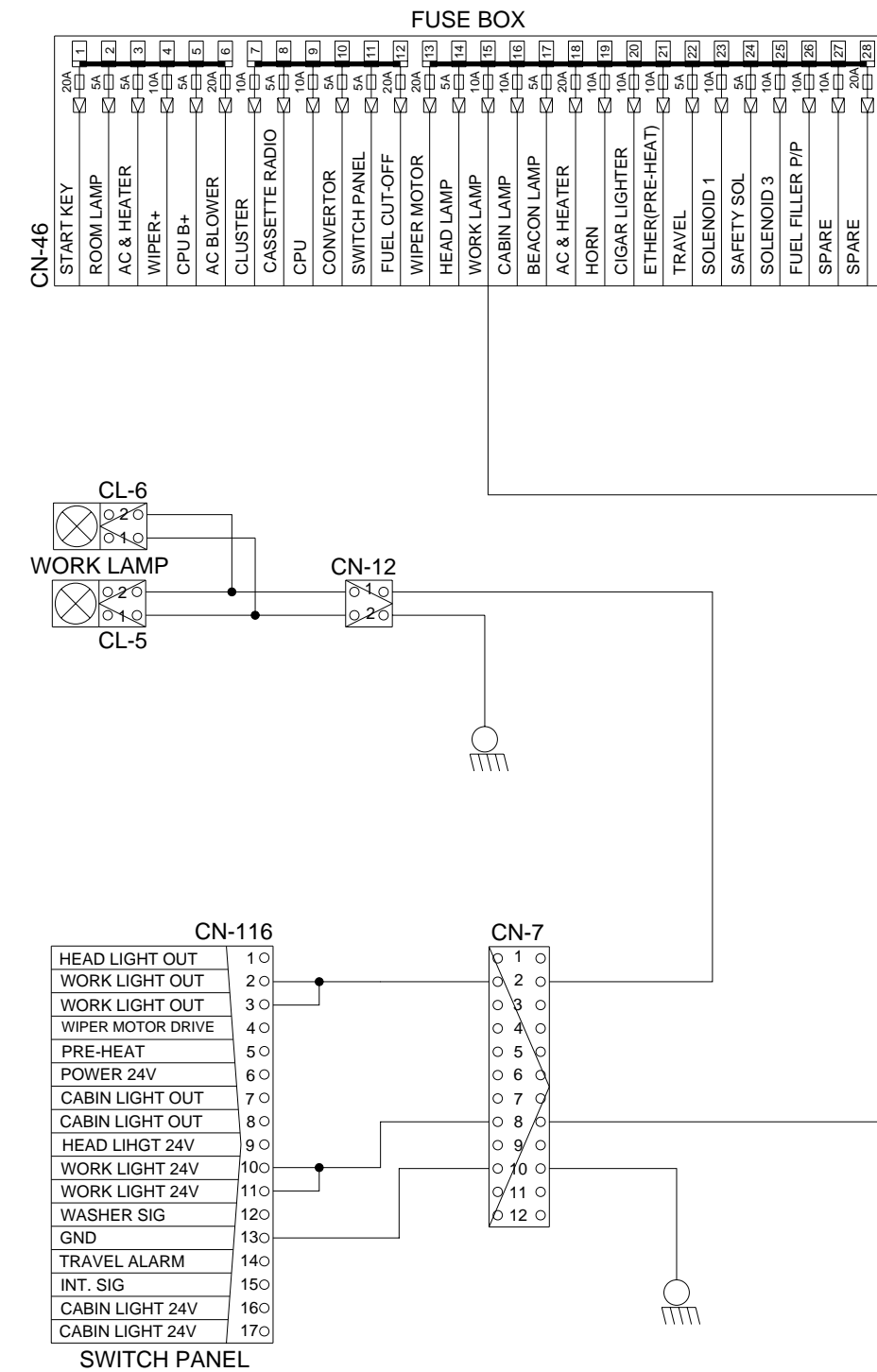
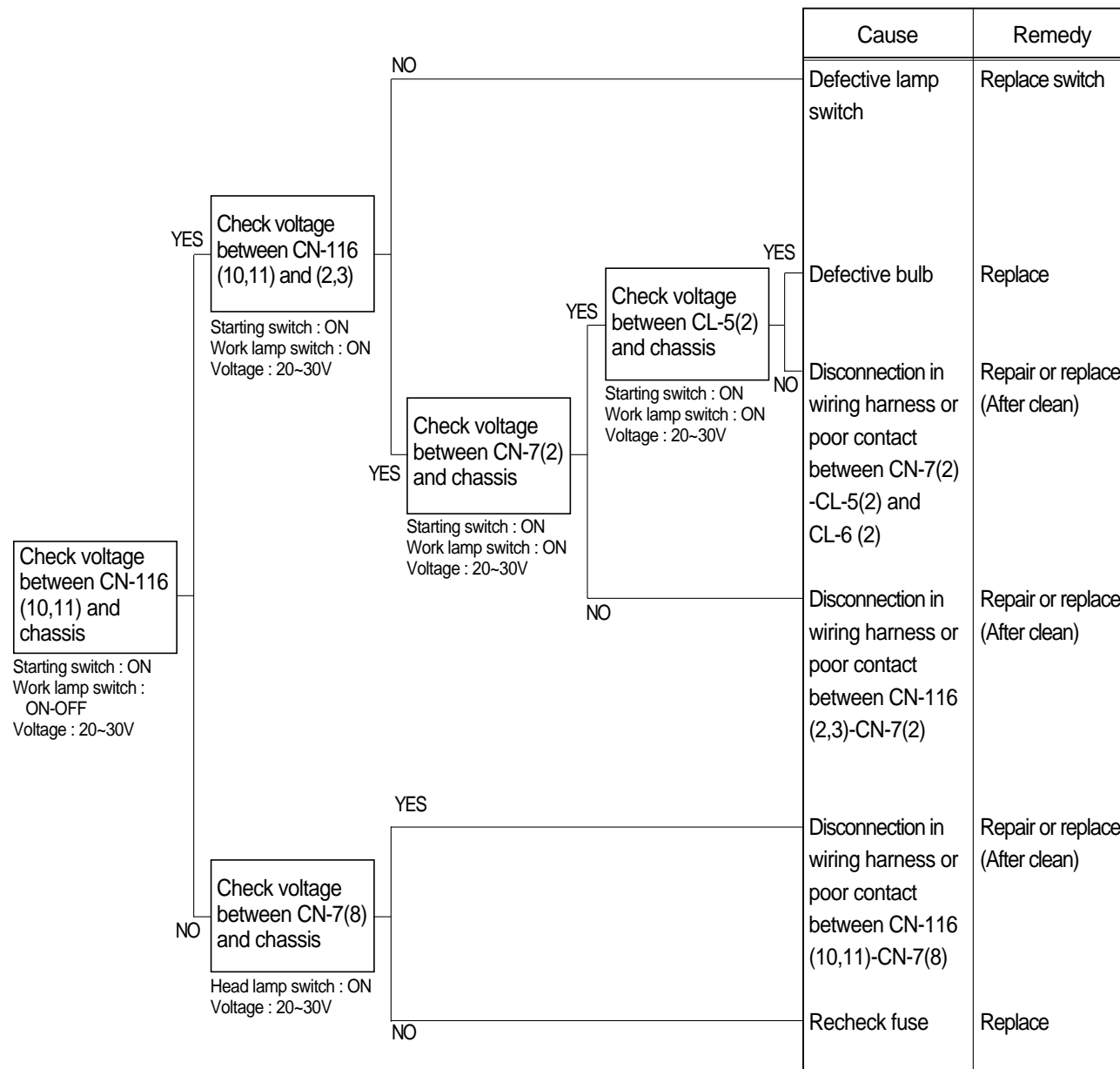

GROUP 4 MECHATRONICS SYSTEM

1. ALL ACTUATORS SPEED ARE SLOW

Boom, Arm, Bucket, Swing and travel speed are slow, but engine speed is good.

Spec : H-mode 2350 ± 50(2250 ± 50)rpm S-mode 2150 ± 50(2100 ± 50)rpm

Before carrying out below procedure, check all the related connectors are properly inserted.

() : TIER II (#1001 AND UP)

1) INSPECTION PROCEDURE

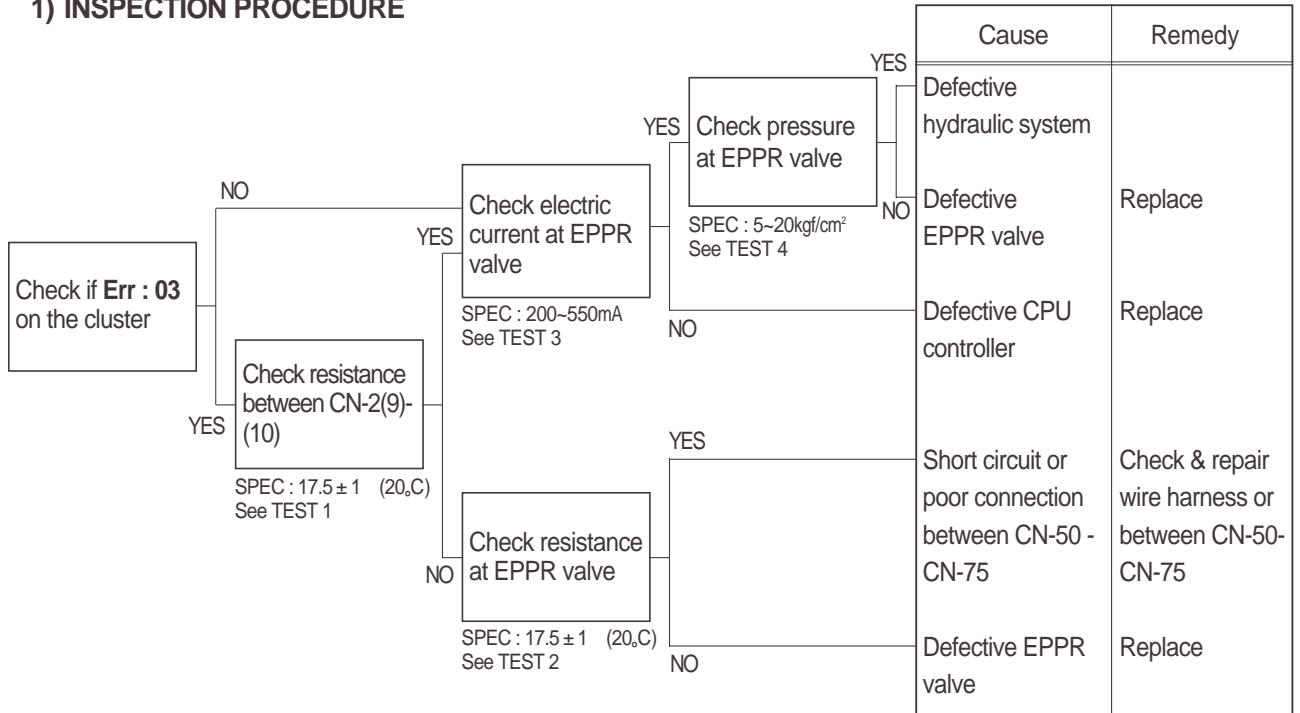

Wiring diagram

TIER I(UP TO #1001)

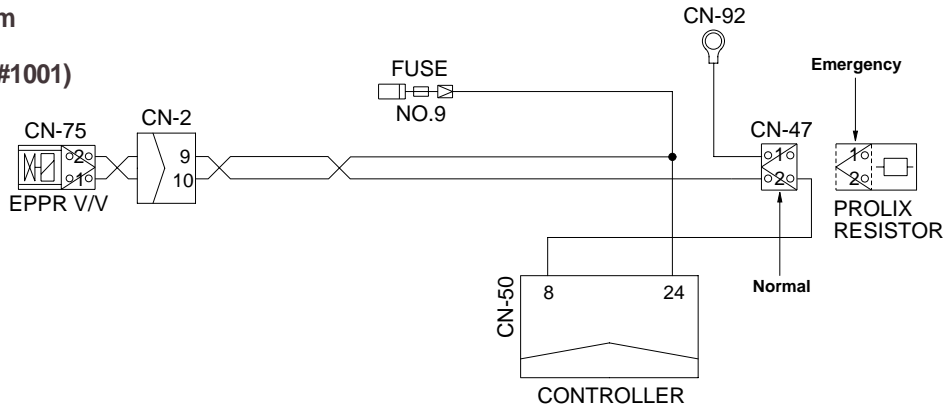

TIER II(#1001 AND UP)

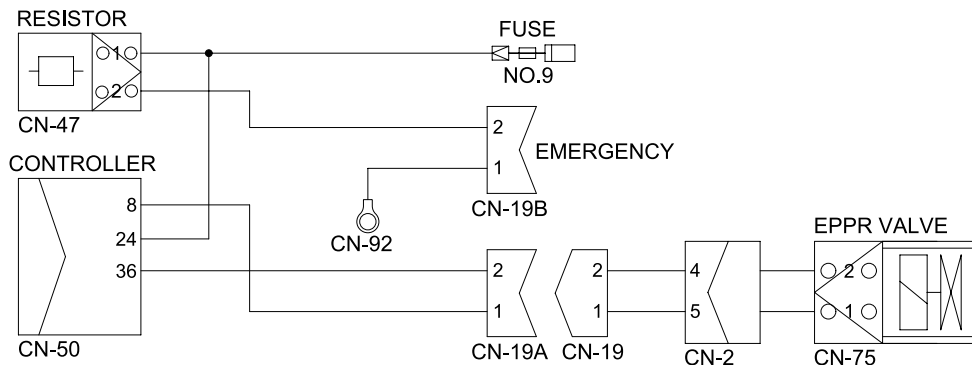

2) TEST PROCEDURE

- (1) **Test 1** : Check resistance at connector CN-2(9)-(10).

Starting key OFF.

Disconnect connector CN-2.

Check resistance between pin and at connector CN-2(9)-(10).

SPEC : 17.5 ± 1 (20°C)

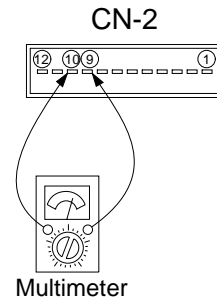

- (2) **Test 2** : Check resistance at connector CN-75.

Starting key OFF.

Disconnect connector CN-75 from EPPR valve at main hydraulic pump.

Check resistance between 2 lines as figure.

SPEC : 17.5 ± 1 (20°C)

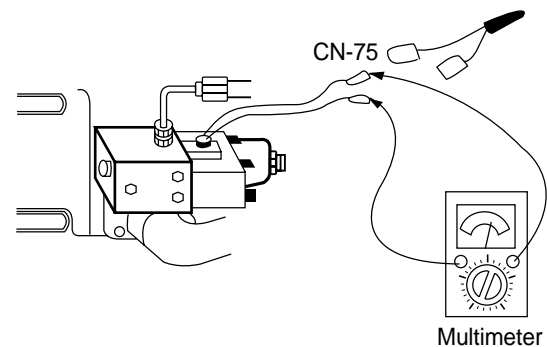

- (3) **Test 3** : Check electric current at EPPR valve.

Install multimeter as figure.

Start engine.

Set the accel dial at "10"(MAX)

Set S-mode and cancel auto decel mode.

If tachometer show approx 2150 ± 50 (2100 ± 50)rpm, check electric current.

() : TIER II (#1001-)

SPEC : 200~550mA (S mode)

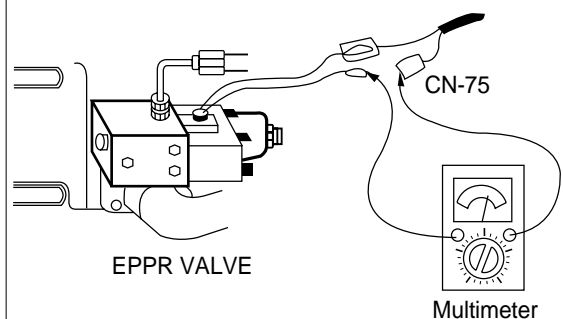

(2) **Test 4** : Check pressure at EPPR valve.
Remove plug and connect pressure gauge as figure.

- Gauge capacity : 0 to 40~50kgf/cm²
(0 to 570~710psi)

Start engine.

Set the accel dial at "10"(Max)

Set S-mode and cancel auto decel mode.

If tachometer show approx 2150 ± 50
(2100 ± 50)rpm, check pressure.

If pressure is not correct, adjust it.

After adjust, test the machine.

() : TIER II (#1001-)

SPEC : 5~20kgf/cm²(70~280psi)

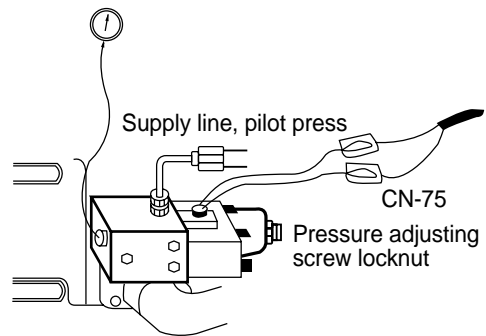

2. ENGINE SPEED IS SLOW AT ALL MODE

Before carrying out below procedure, check all the related connectors are properly inserted.

1) INSPECTION PROCEDURE

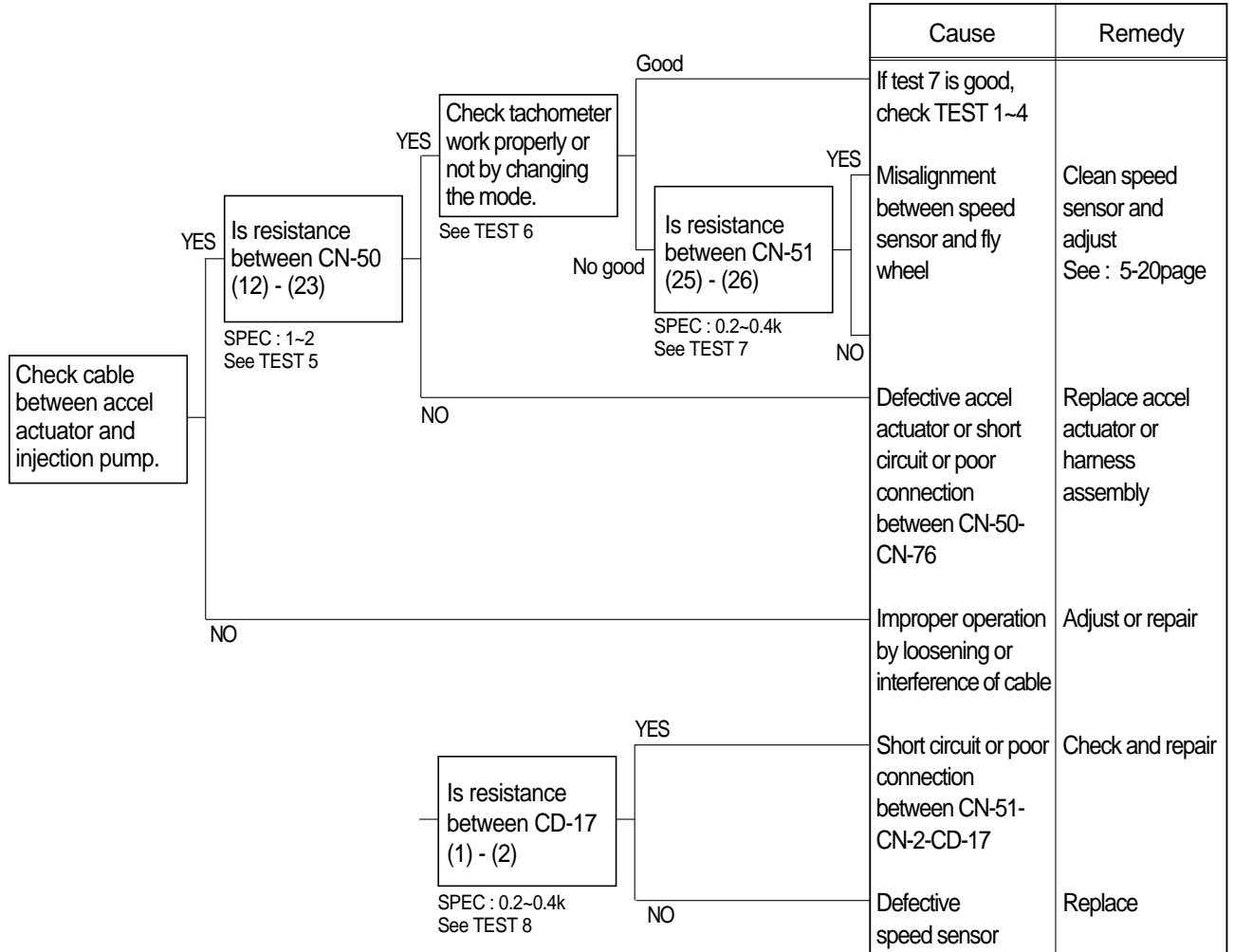

Wiring diagram

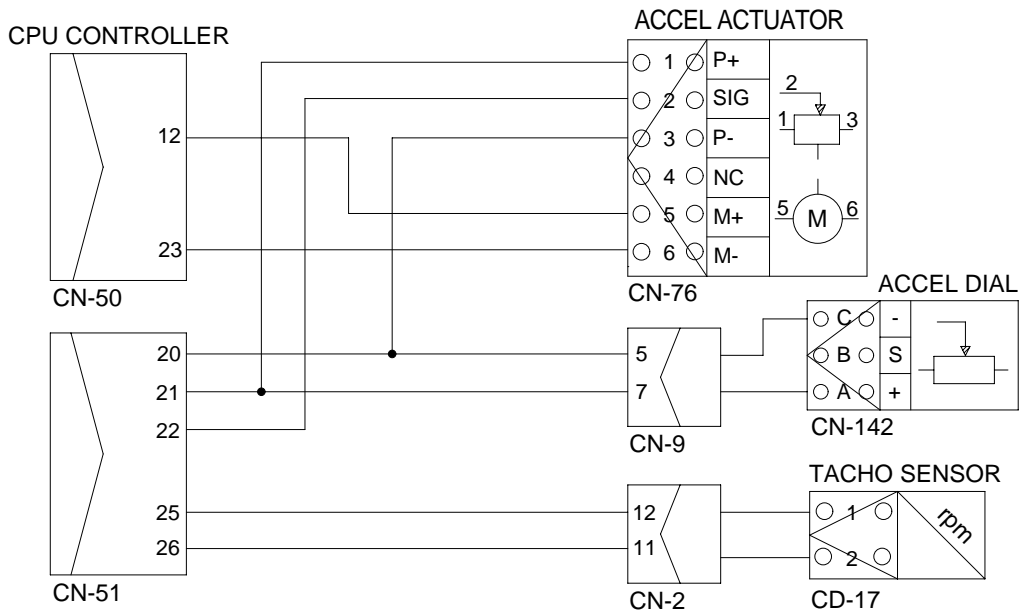

2) TEST PROCEDURE

- (1) **Test 5** : Check resistance between CN-50 (12)-(23).

Starting key OFF.

Disconnect connector CN-50 from CPU controller.

Check resistance as figure.

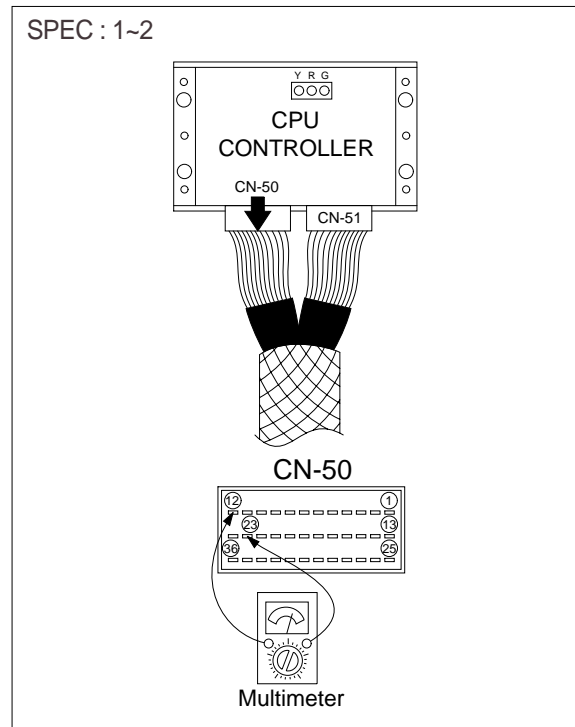

- (2) **Test 6** : Check tachometer(Work properly or not)

Start engine.

Check tachometer reading.

Unit : rpm

Spec		Remark
H-mode	2350 ± 50	Check rpm after cancel the Auto decel mode.
	*2250 ± 50	
S-mode	2350 ± 50	
	*2100 ± 50	

* TIER II (#1001-)

- (3) **Test 7** : Check resistance between CN-51 (25) and CN-51(26).

Starting key OFF.

Disconnect connector CN-51 from CPU controller.

Check resistance as figure.

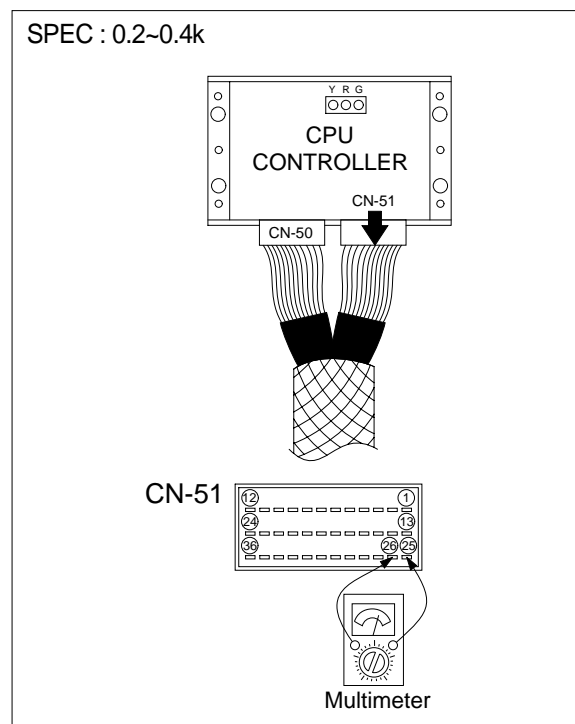

(4) **Test 8** : Check resistance at speed sensor.

Starting key OFF.

Disconnect connector CD-17 of speed sensor at engine flywheel housing.

Check resistance as figure.

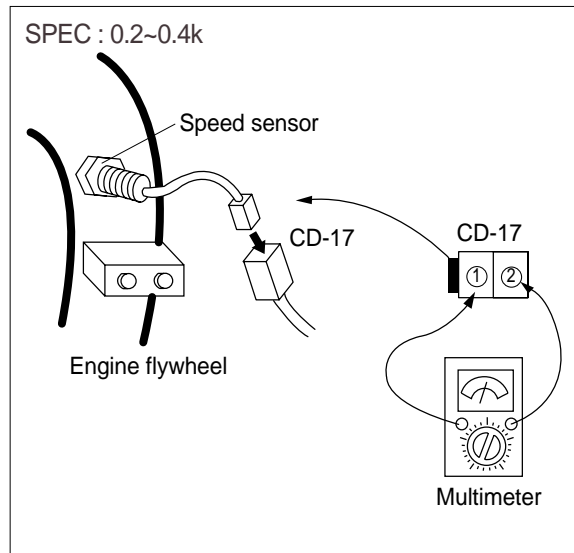

3. ENGINE STALL

Before carrying out below procedure, check all the related connectors are properly inserted.

1) INSPECTION PROCEDURE

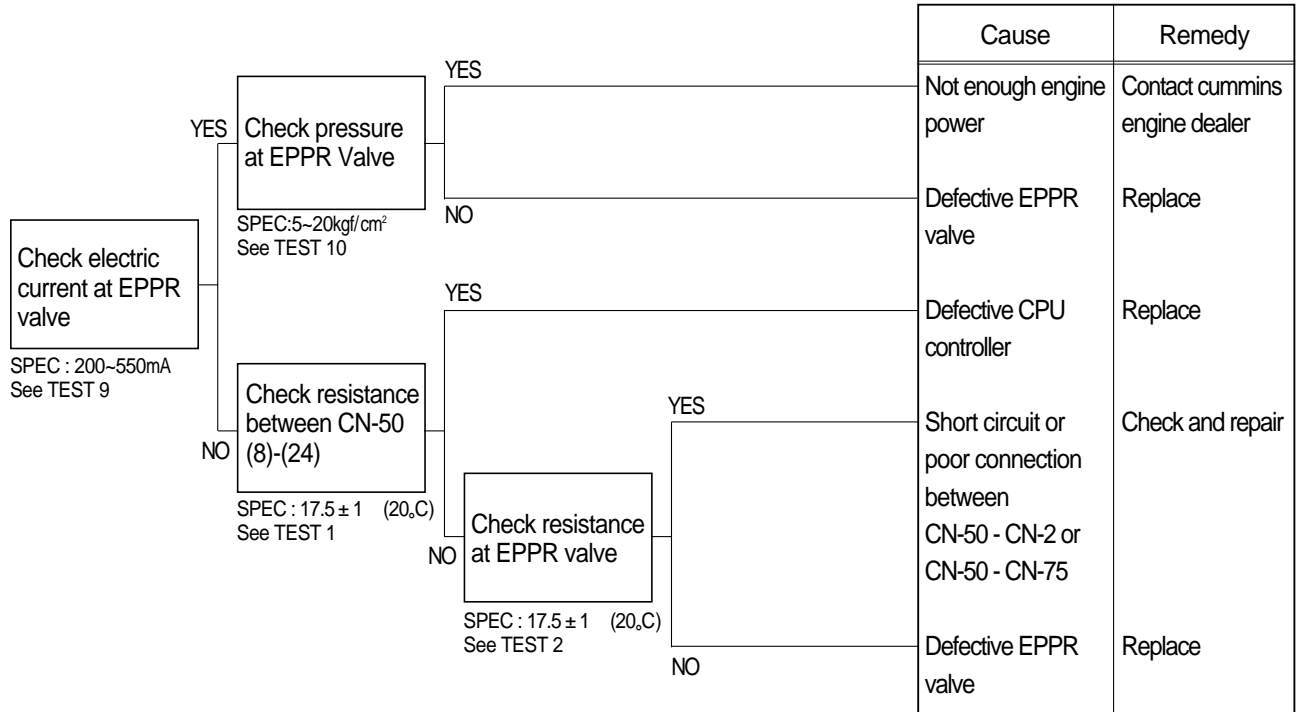

Wiring diagram

TIER I (UP TO #1001)

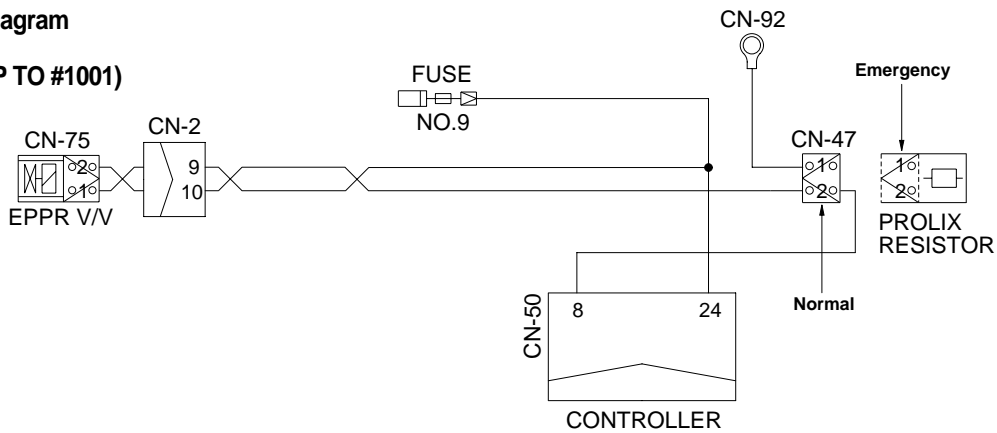

TIER II (#1001 AND UP)

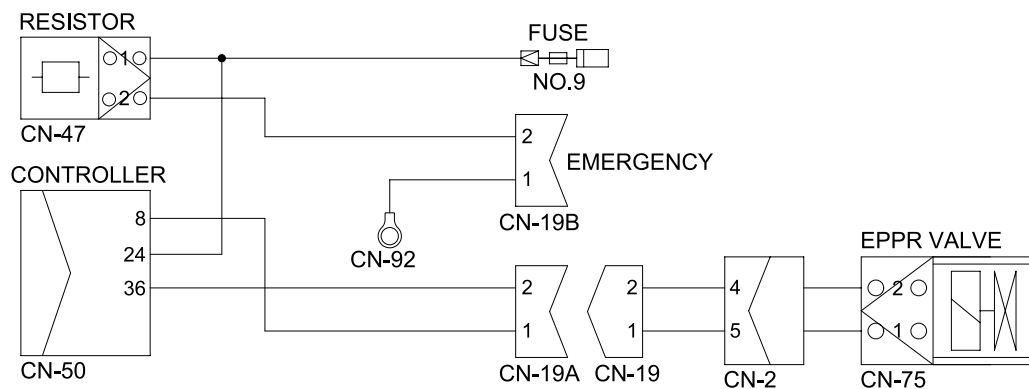

2) TEST PROCEDURE

- (1) **Test 9** : Check electric current at EPPR valve at S-mode

Install multimeter as figure.

Start engine.

Set the accel dial at "10"(max)

Set S-mode with 2150 ± 50 (2100 ± 50)rpm.

Check electric current.

() : TIER II (#1001-)

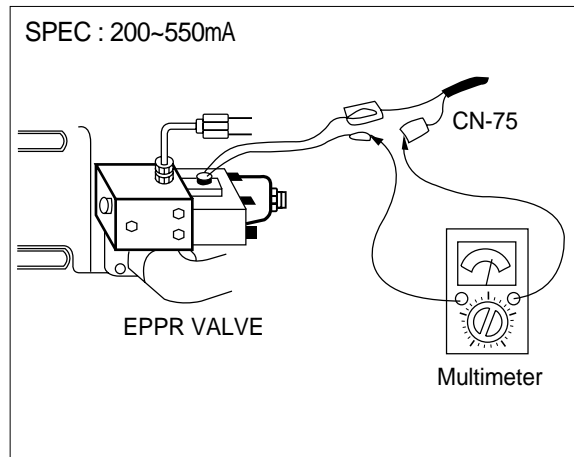

- (2) **Test 10** : Check pressure at EPPR valve at S-mode

Connect pressure gauge at EPPR valve.

Start engine.

Set the accel dial at "10"(max)

Set S-mode with 2150 ± 50 (2100 ± 50)rpm.

Operate bucket lever completely push or pull.

Hold arm lever at the end of stroke.

Check pressure at relief position.

() : TIER II (#1001-)

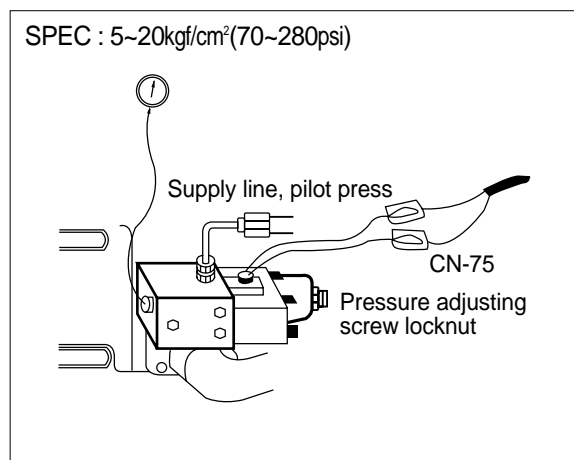

4. MALFUNCTION OF CLUSTER OR MODE SELECTION SYSTEM

Before carrying out below procedure, check all the related connectors are properly inserted.

1) INSPECTION PROCEDURE

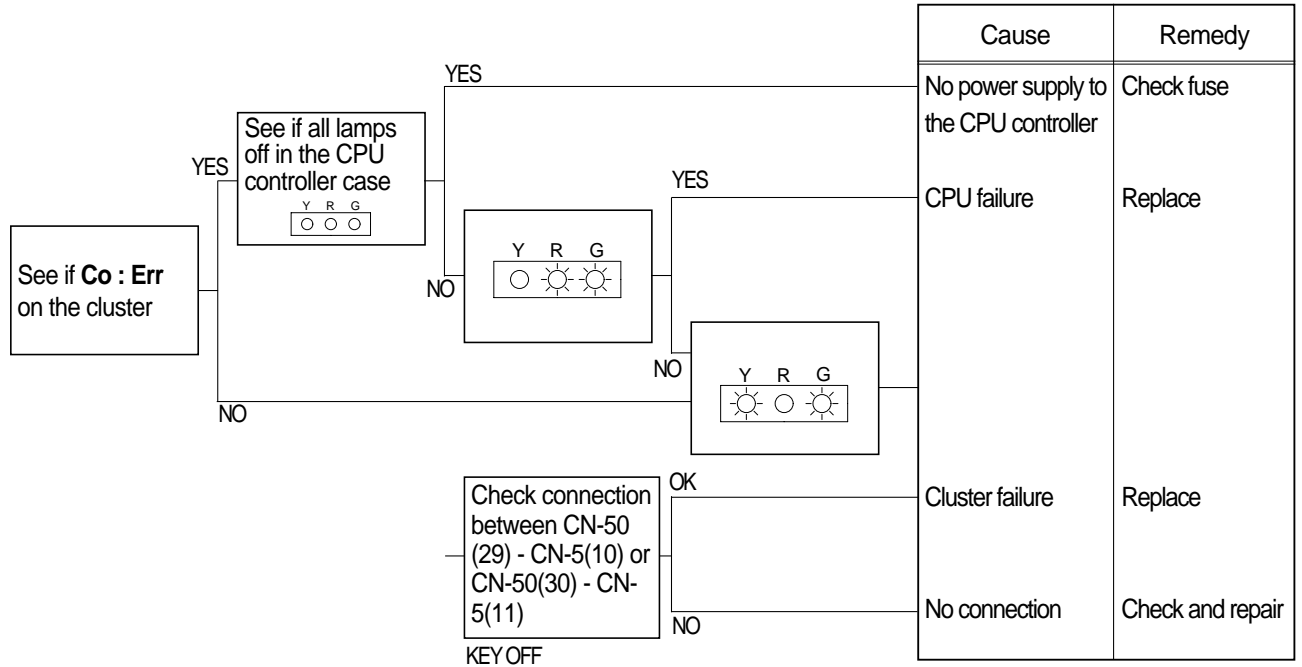

Wiring diagram

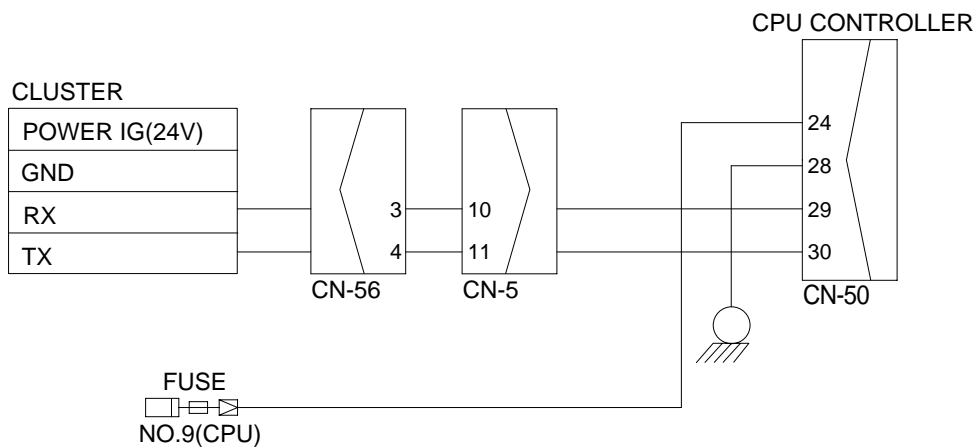

5. SLOW ACTION OF ENGINE SPEED CHANGE WHEN CHANGE THE MODE

Before carrying out below procedure, check all the related connectors are properly inserted.

1) INSPECTION PROCEDURE

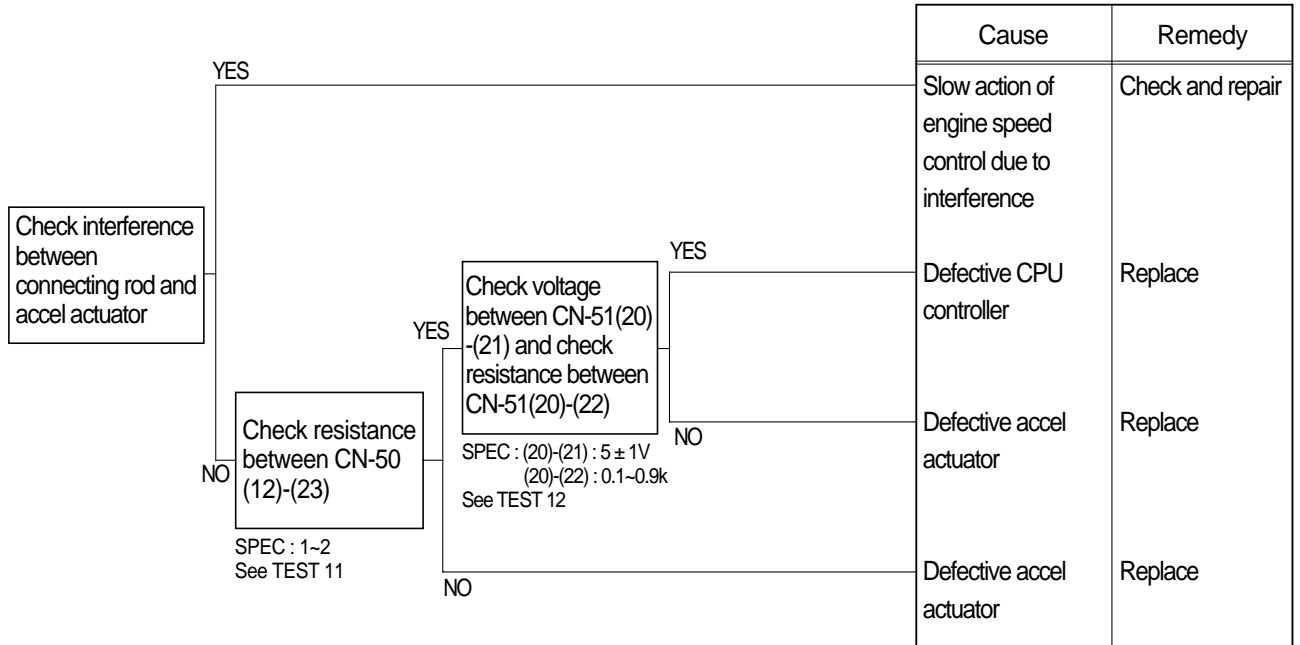

Wiring diagram

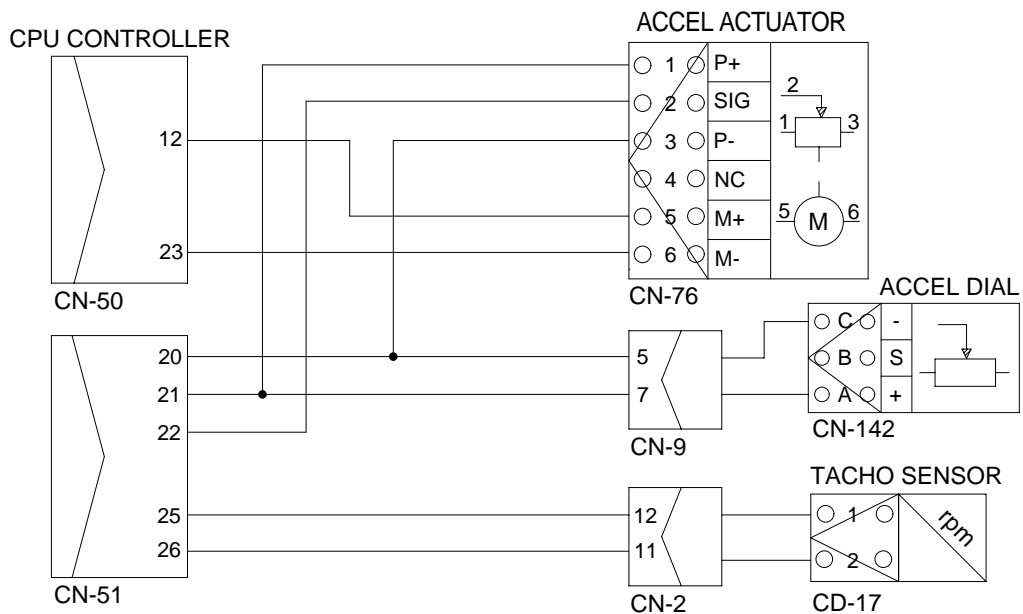

2) TEST PROCEDURE

- (1) **Test 11** : Check resistance.
Starting key OFF.
Disconnect connector CN-50 from CPU controller.
Check resistance between CN-50(12)-(23) as figure.

SPEC : 1~2

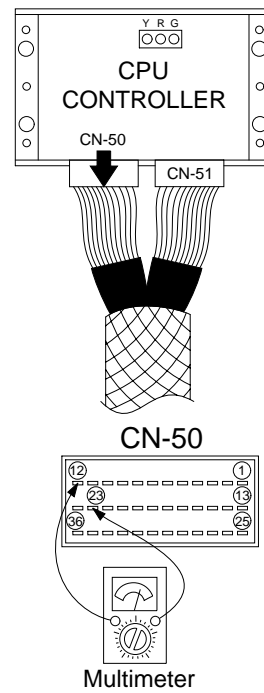

- (2) **Test 12** : Check voltage and resistance.
 Check resistance between CN-51(20)-
 (22).
- Starting key OFF.
 - Disconnect connector CN-51 from CPU controller.
 - Check resistance value with multimeter as figure.

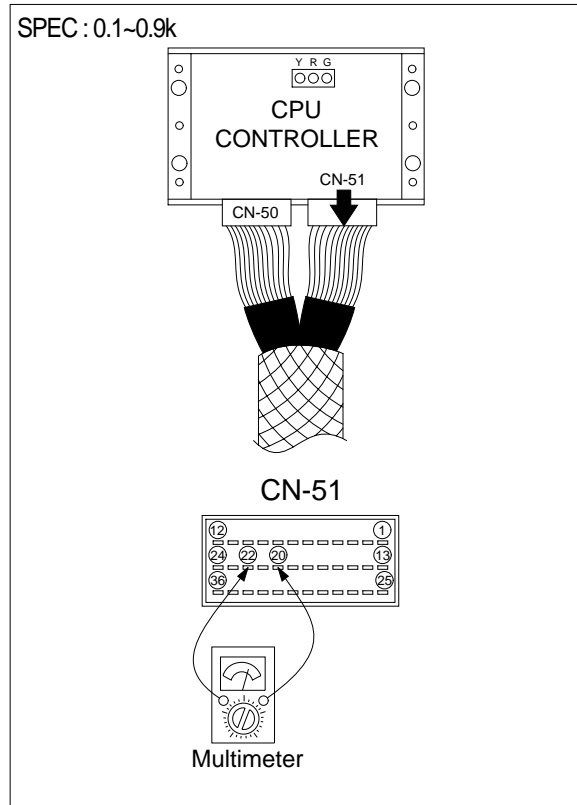

Check voltage between CN-51(20) and
 CN-51(21).

- Prepare 2 pieces of thin sharp pin, steel or copper.
- Starting key ON.
- Insert prepared pins to rear side of connectors : One pin to CN-51(20)
 Other pin to CN-51(21)
- Check voltage.

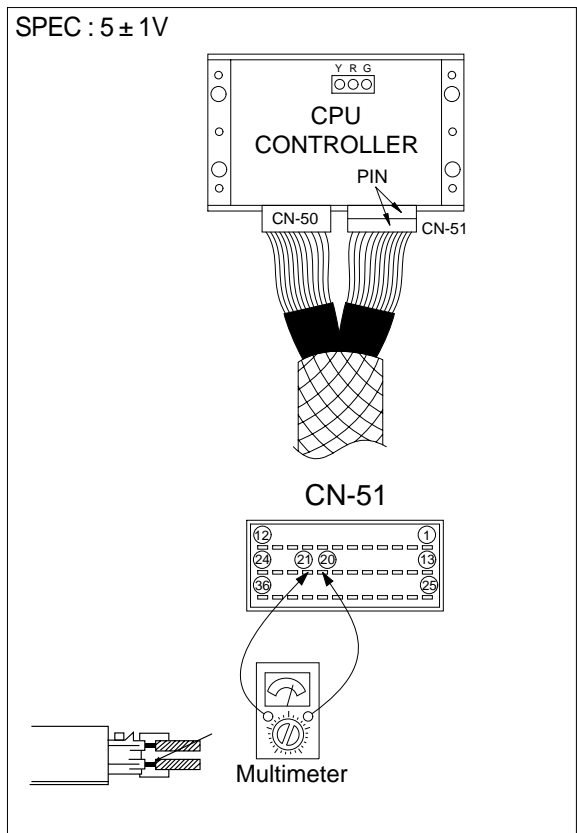

6. AUTO DECEL SYSTEM DOES NOT WORK

Before carrying out below procedure, check all the related connectors are properly inserted.

1) INSPECTION PROCEDURE

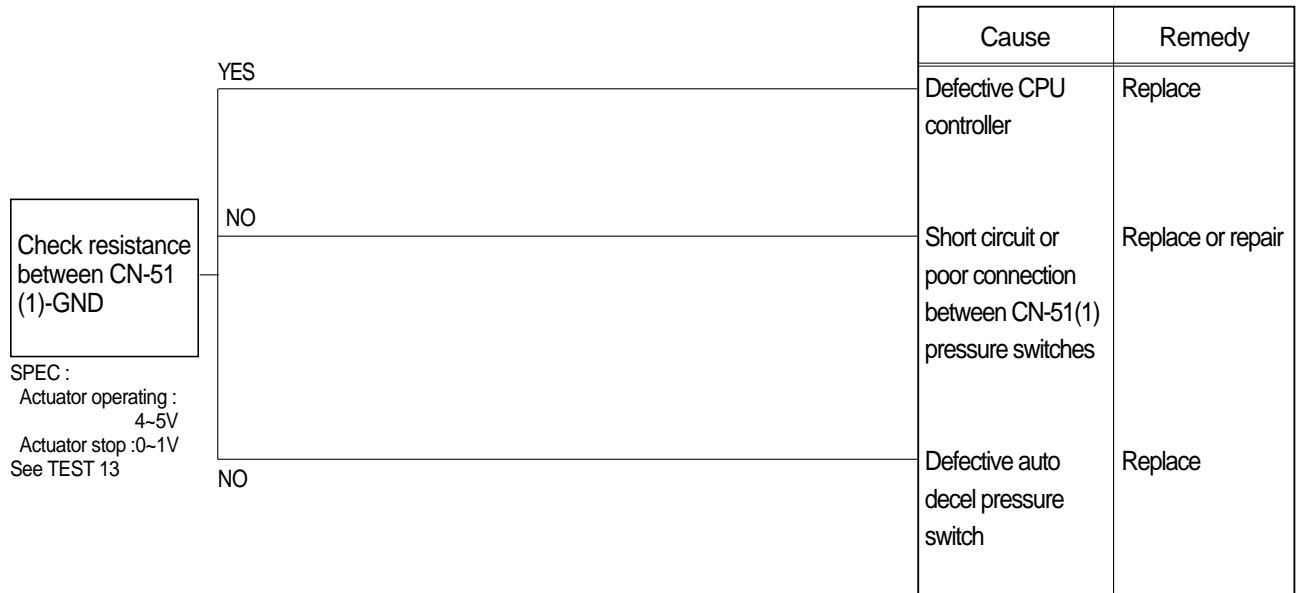

Wiring diagram



2) TEST PROCEDURE

(1) **Test 13** : Check voltage at CN-51(1) and ground.

Prepare 1 piece of thin sharp pin, steel or copper.

Starting key ON.

Insert prepared pin to rear side of connectors : One pin to (1) of CN-51.

Check voltage as figure.

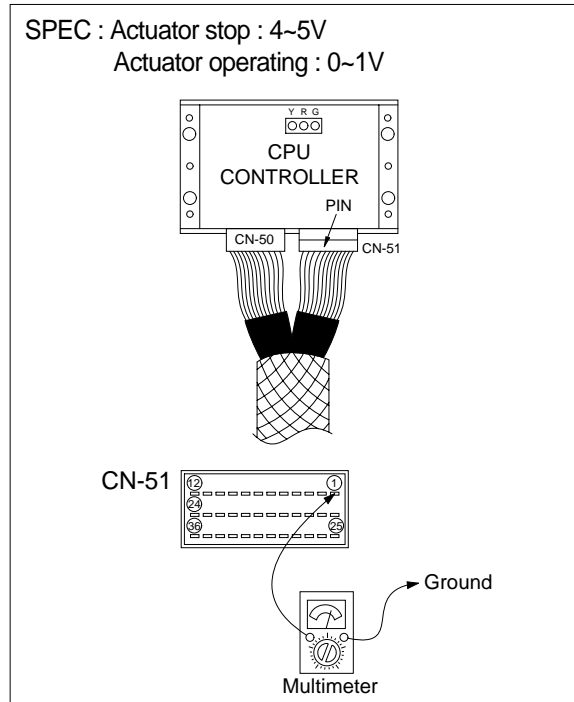

7. MALFUNCTION OF WARMING UP

Before carrying out below procedure, check all the related connectors are properly inserted.

1) INSPECTION PROCEDURE

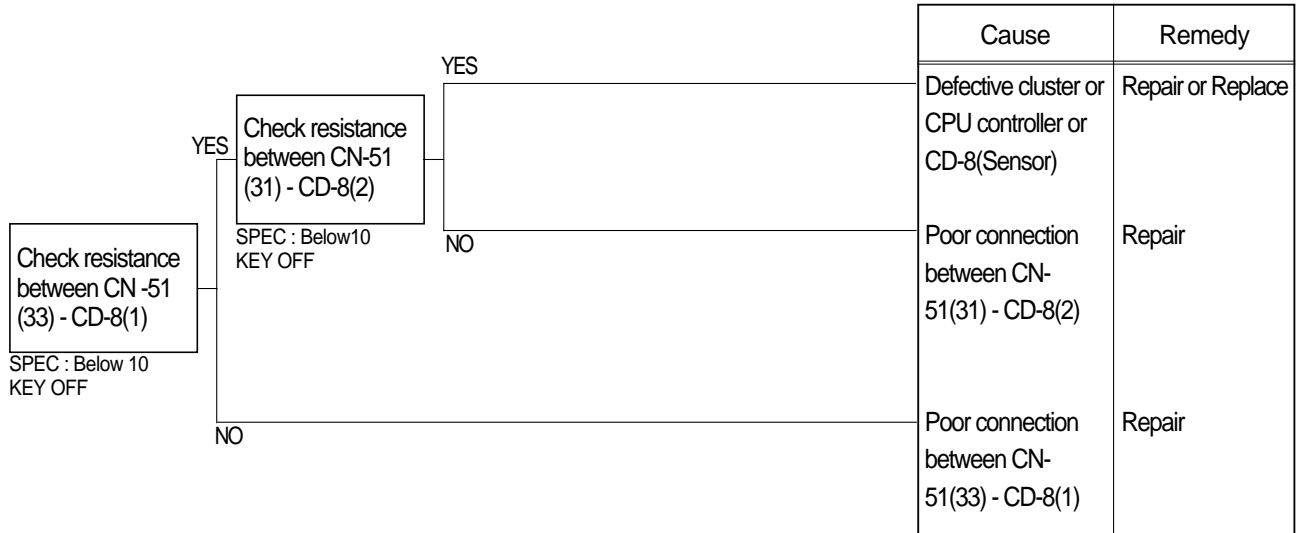

Wiring diagram

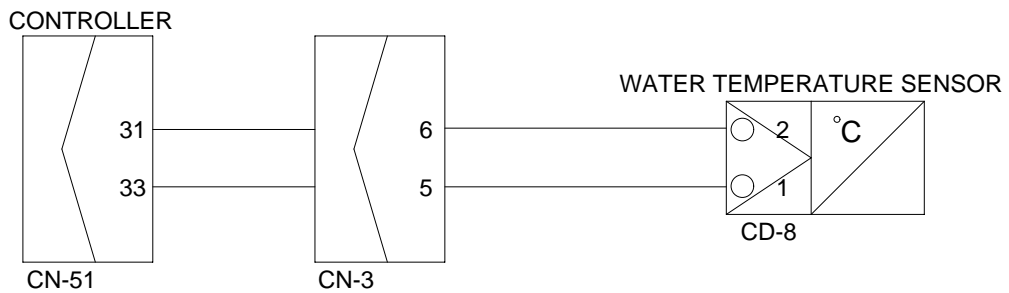

8. MALFUNCTION OF POWER MAX

Before carrying out below procedure, check all the related connectors are properly inserted.

1) INSPECTION PROCEDURE

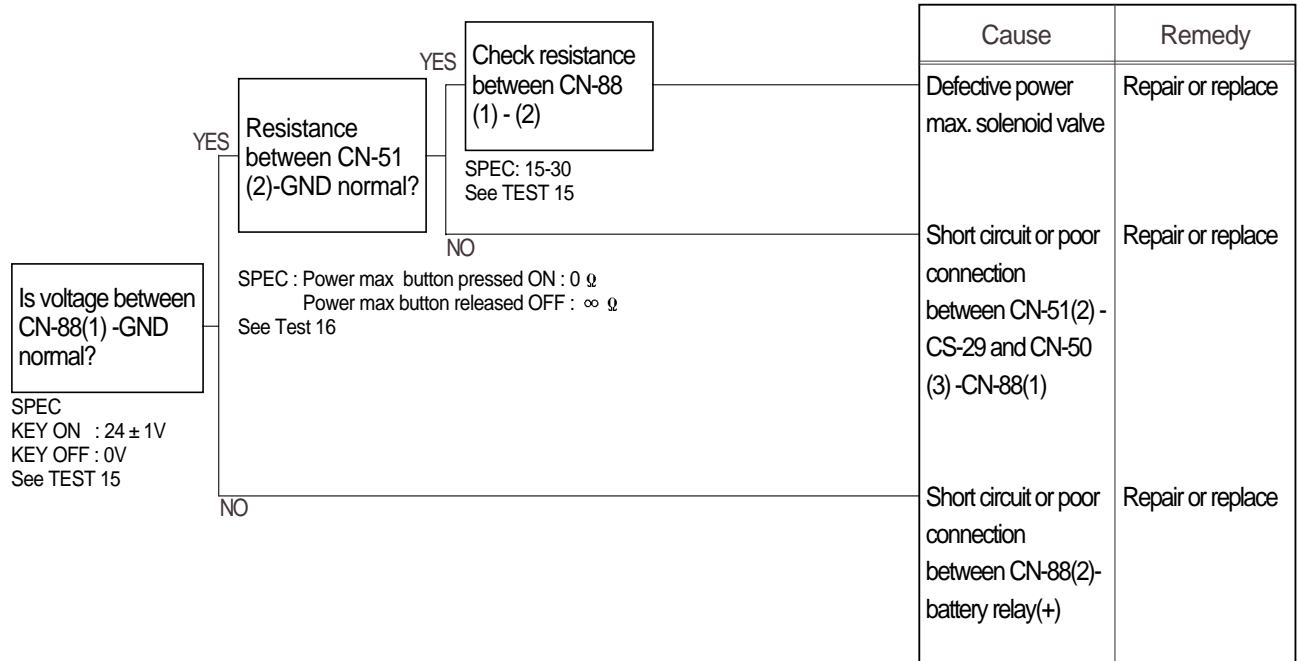

Wiring diagram

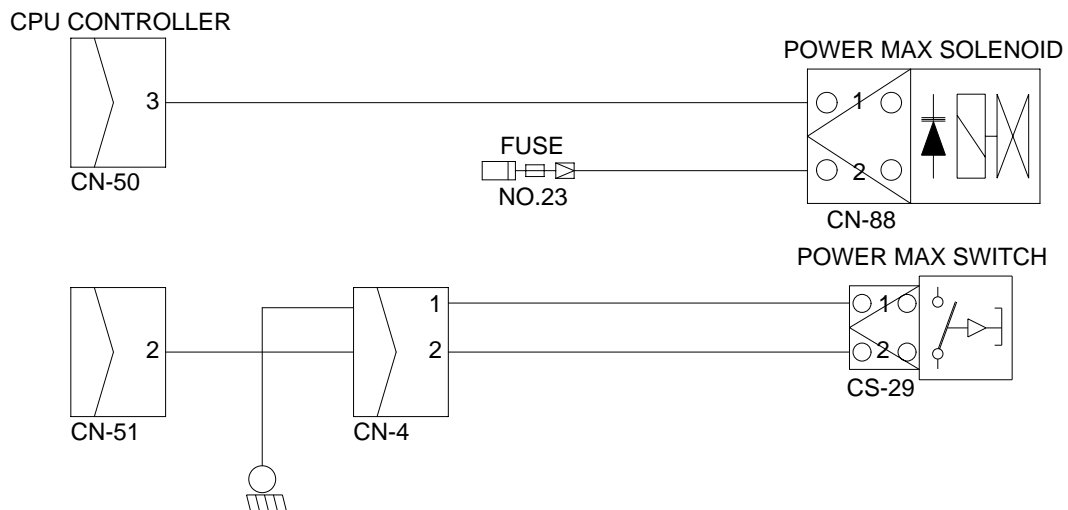

2) TEST PROCEDURE

- (1) **Test 15:** Check voltage between connector CN-88 - GND.

Start key ON.

Disconnect connector CN-88 from power max solenoid valve.

Check voltage as figure.

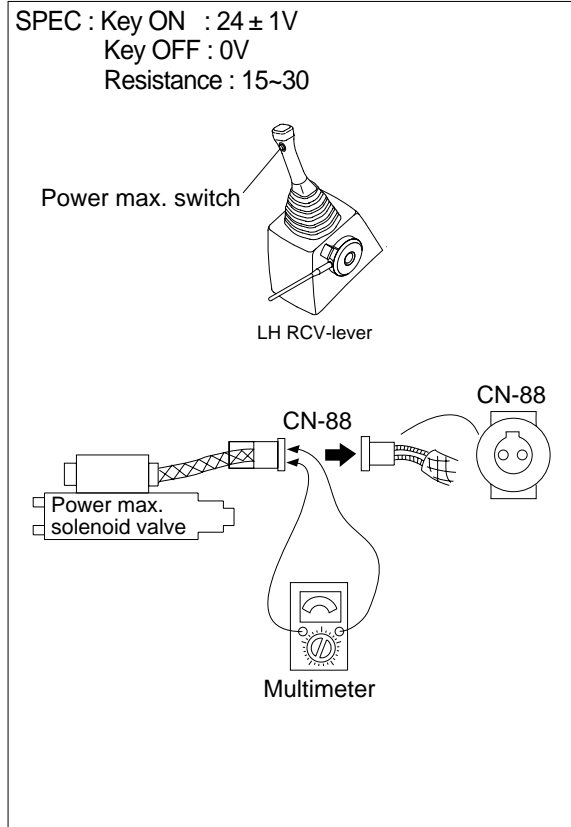

- (2) **Test 16:** Check resistance between connector CN-51(2)-GND.

Starting key OFF.

Remove CPU controller and disconnect connector CN-51 from CPU controller.

Check resistance as figure.

