

GROUP 2 MODE SELECTION SYSTEM

1. POWER MODE SELECTION SYSTEM

A. TIER I (UP TO #1000)

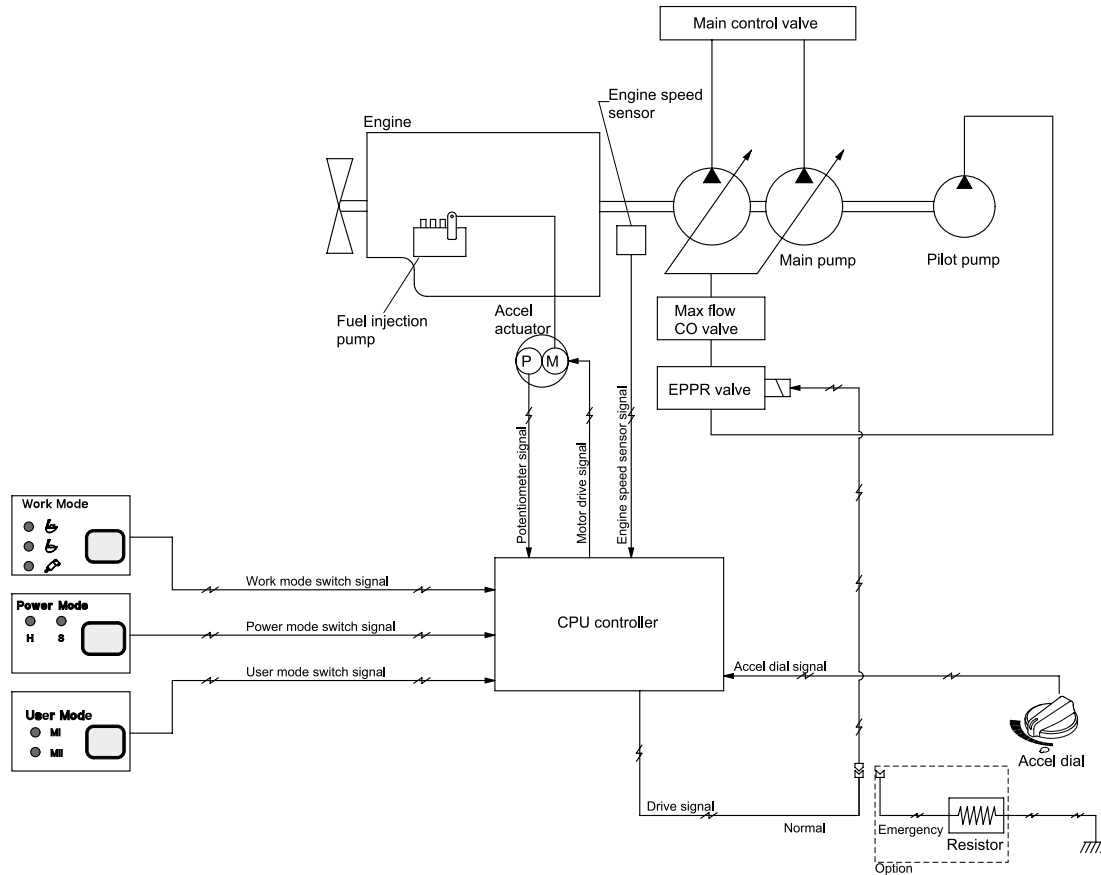

Mode selection system(Micro computer based electro-hydraulic pump and engine mutual control system) optimizes the engine and pump performance.

The combination of 2 power modes(H, S) and accel dial position(10 set) makes it possible to use the engine and pump power more effectively corresponding to the work conditions from a heavy and great power requesting work to a light and precise work.

Mode	Application	Power set (%)	Engine rpm		Power shift by EPPR valve			
			Unload	Load	Default		Other case	
					Current (mA)	Pressure (kgf/cm ²)	Current (mA)	Pressure (kgf/cm ²)
H	High power	100	2350 ± 50	2100	160 ± 30	0	290	8
S	Standard power	85	2200 ± 50	2000	340 ± 30	11	390	15
AUTO DECEL	Engine deceleration	-	1200 ± 100	-	700 ± 30	35	700 ± 30	35
One touch decel	Engine quick deceleration	-	950 ± 100	-	700 ± 30	35	700 ± 30	35
KEY START	Key switch start position	-	950 ± 100	-	700 ± 30	35	700 ± 30	35

Other case can be set by pressing the "travel speed" switch and "buzzer stop switch" for 2 seconds at the same time in "model & version" display on the cluster(for detail, see 5-21)

B. TIER II (#1001 AND UP)

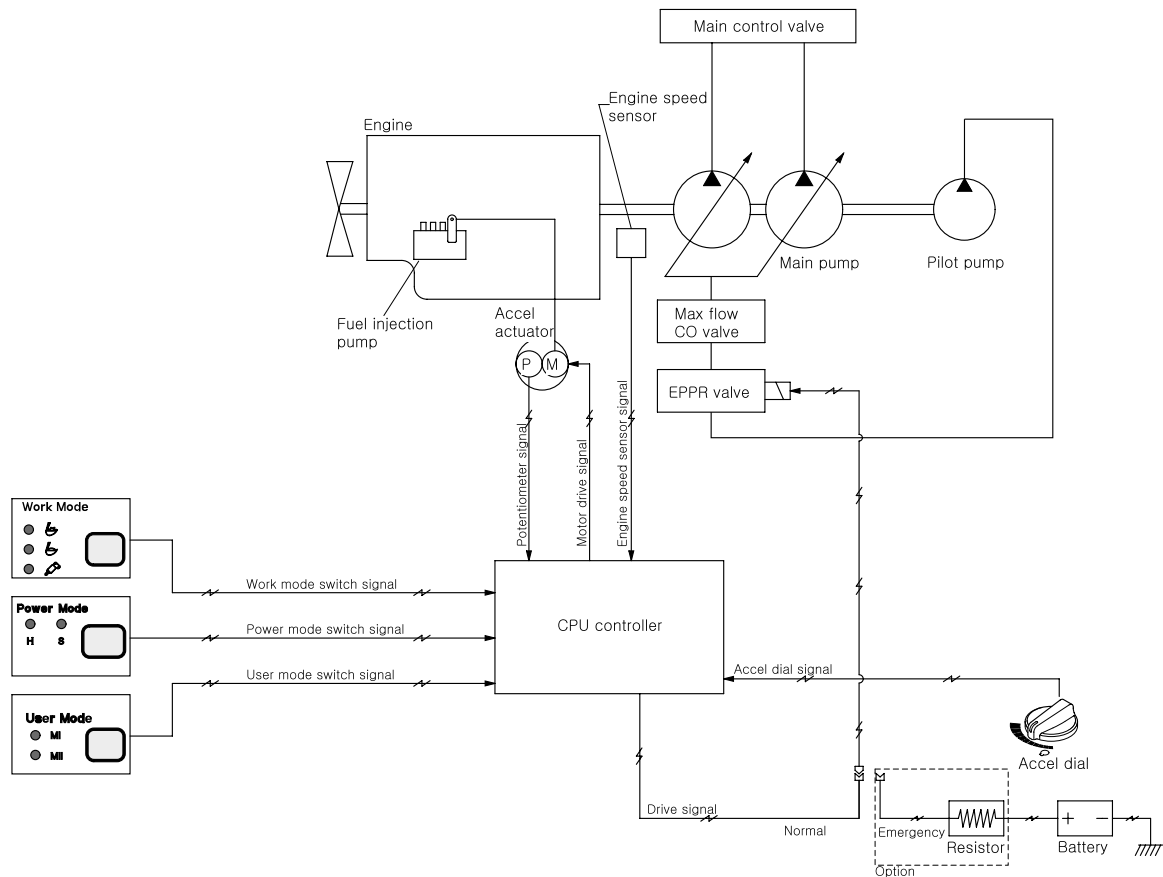

Mode selection system(Micro computer based electro-hydraulic pump and engine mutual control system) optimizes the engine and pump performance.

The combination of 2 power modes(H, S) and accel dial position(10 set) makes it possible to use the engine and pump power more effectively corresponding to the work conditions from a heavy and great power requesting work to a light and precise work.

Mode	Application	Power set (%)	Engine rpm		Power shift by EPPR valve			
			Unload	Load	Default		Other case	
					Current (mA)	Pressure (kgf/cm ²)	Current (mA)	Pressure (kgf/cm ²)
H	High power	91	2250 ± 50	2050	250 ± 30	5	250	5
S	Standard power	82	2100 ± 50	1900	290 ± 30	8	340	11
AUTO DECEL	Engine deceleration	-	1200 ± 100	-	670 ± 30	31	670 ± 30	31
One touch decel	Engine quick deceleration	-	850 ± 100	-	670 ± 30	31	670 ± 30	31
KEY START	Key switch start position	-	850 ± 100	-	670 ± 30	31	670 ± 30	31

Other case can be set by pressing the "travel speed" switch and "buzzer stop switch" for 2 seconds at the same time in "model & version" display on the cluster(for detail, see 5-21)

2. WORK MODE SELECTION SYSTEM

3 work modes can be selected for the optional work speed of the machine operation.

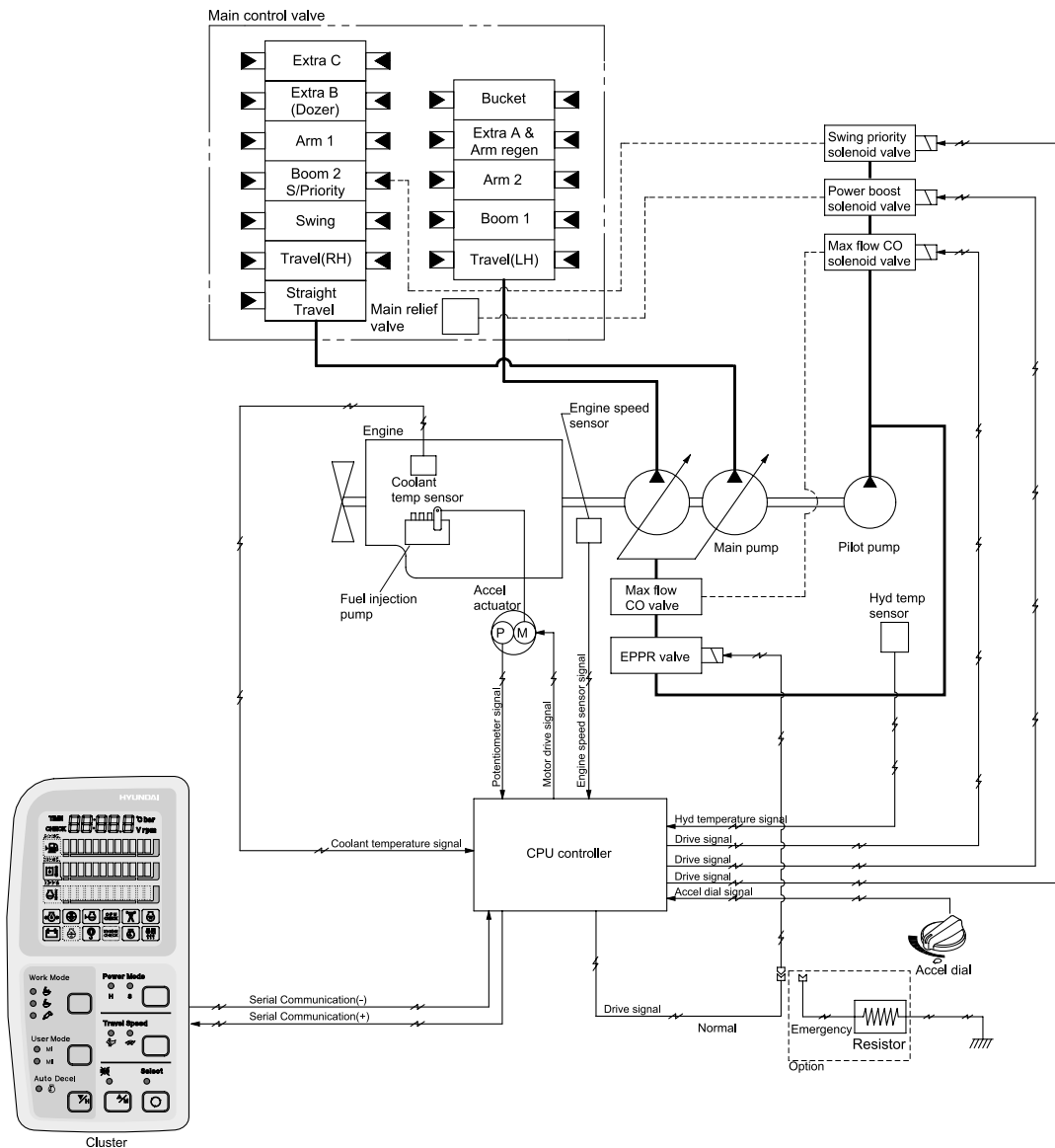

1) HEAVY DUTY WORK MODE

Boom and arm operation speed faster than general work mode.

2) GENERAL WORK MODE

When key switch is turned ON, this mode is selected and swing operation speed is faster than heavy duty work mode.

3) BREAKER OPERATION MODE

It sets the pump flow to the optimal operation of breaker by activating the max flow cut-off solenoid.

Work mode	Swing priority solenoid	Max flow cut-off solenoid
Heavy duty	OFF	OFF
General	ON	OFF
Breaker	OFF	ON

3. USER MODE SELECTION SYSTEM

Through 2 memory sets of MI and MII, an operator can change the engine and pump power and memorize it for his preference.

Mode	Operation
MI (Memory mode 1)	High idle rpm, auto decel rpm
MII (Memory mode 2)	EPPR pressure can be modulated and memorized separately

HOW TO MODULATE THE MEMORY SET

- Each memory mode has a initial set which are mid-range of max engine speed, auto decel rpm, and EPPR valve input current. When you select MI or MII, cluster LCD displays.
- To change the engine high idle speed, press the USER mode switch and SELECT switch at the same time and then ACCEL blinks at 0.5 seconds interval.
 - By pressing ▲ or ▼ switch, █ will increase or decrease.
- To change DECEL rpm, press the USER mode switch and SELECT switch once more and then DECEL blinks at 0.5 seconds interval.
 - By pressing ▲ or ▼ switch, █ will increase or decrease.
- To change EPPR current, press the USER mode switch and SELECT switch one more and then EPPR blinks at 0.5 seconds interval.
 - By pressing ▲ or ▼ switch, █ will increase or decrease.



· LCD segment vs parameter setting

Segment (█)	ACCEL (rpm)	DECEL (rpm)	EPPR (mA)
1	High idle-900	Low idle(950) *850	150
2	High idle-800	1050 *950	200
3	High idle-700	1100 *1000	250
4	High idle-600	1150 *1100	300
5	High idle-500	Decel rpm(1200)	350
6	High idle-400	1250	400
7	High idle-300	1300	450
8	High idle-200	1350	500
9	High idle-100	1400	550
10	High idle	1500	600

* : TIER-II (#1001-)

- To memorize the final setting, press the USER mode switch and SELECT switch one more time.

