

3) #1001 AND UP (TIER II)

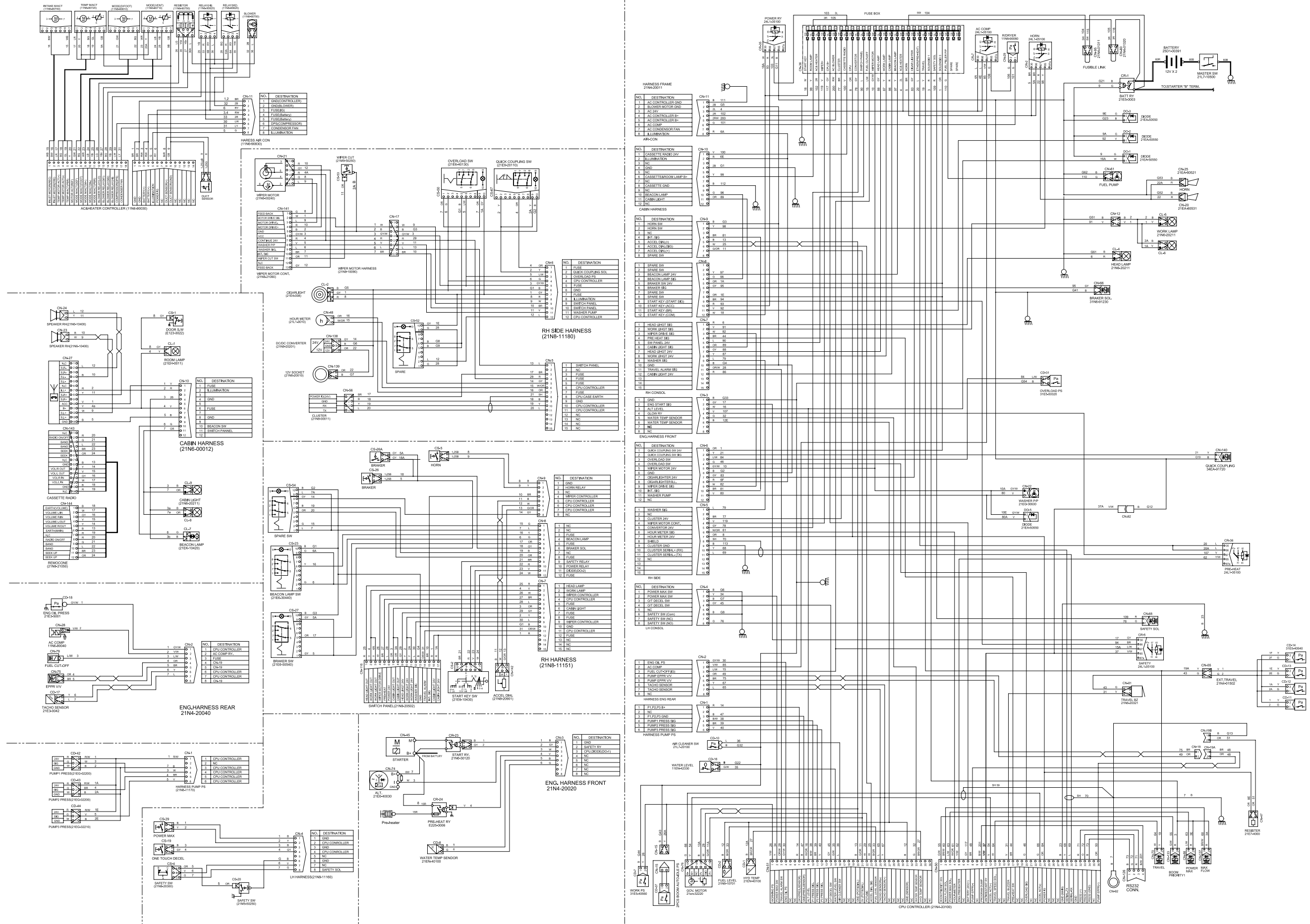

1. POWER CIRCUIT

The negative terminal of battery is grounded to the machine chassis.

When the start switch is in the OFF position, the current flows from the positive battery terminal as shown below.

1) OPERATING FLOW

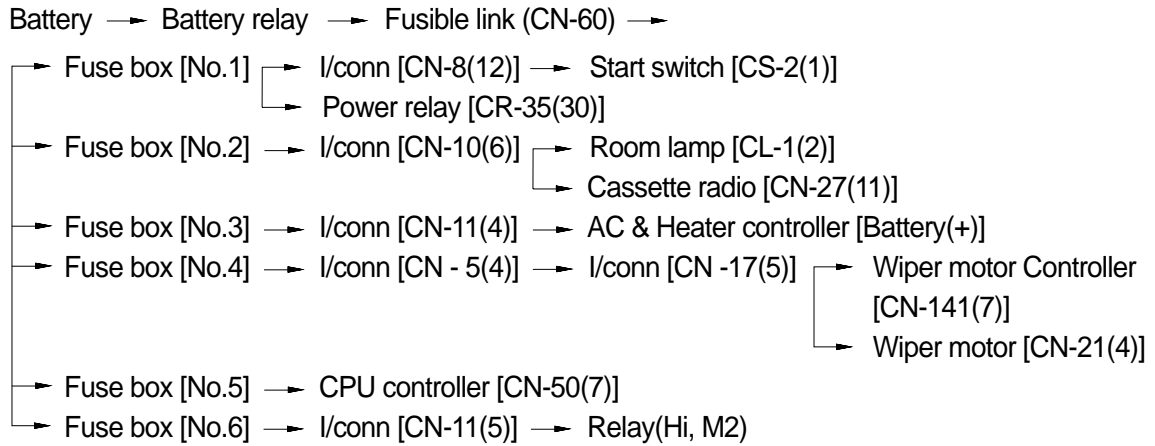

I/conn : Intermediate connector

2) CHECK POINT

| Engine | Start switch | Check point | Voltage |
|--------|--------------|----------------------------------------------------------------------------|----------------------------|
| OFF | OFF | ① - GND (Battery 2 EA) ② - GND (Battery 2 EA) ③ - GND (Fusible link) | 20~25V 20~25V 20~25V |

GND : Ground

POWER CIRCUIT

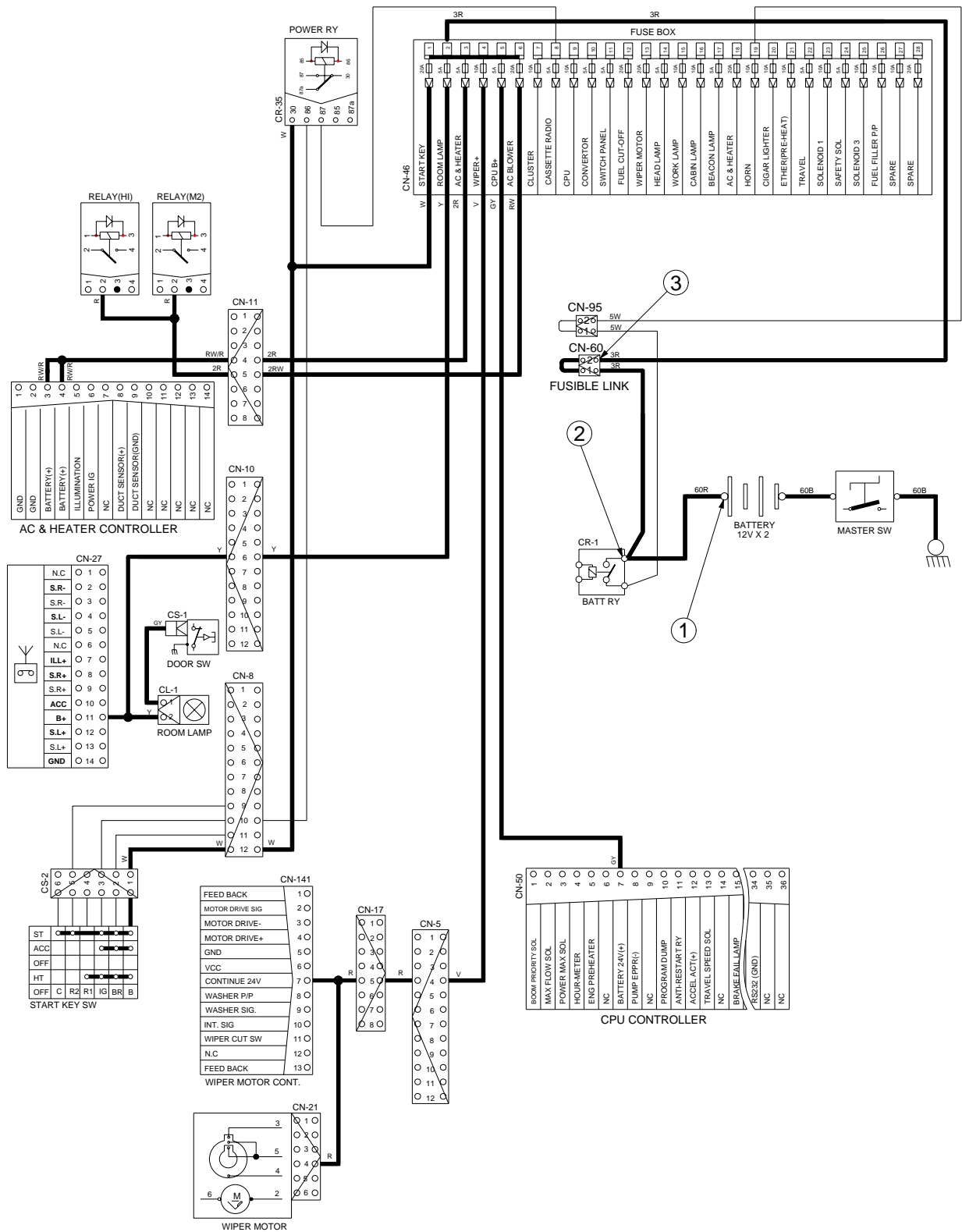

2. STARTING CIRCUIT

A. TIER I(UP TO #1000)

1) OPERATING FLOW

Battery(+) terminal → Battery relay[CR-1] → Fusible link → Fuse box No.1
 → I/conn [CN-8(12)] → Start key [CS-2(1)]

Start switch : ON

→ Start switch ON [CS-2(2)] → I/conn [CN-8(11)] → Diode[DO-2] →
 Battery relay [CR-1]:Battery relay operating(All power is supplied with the electric component)
 → Start switch ON [CS-2(3)] → I/conn [CN-8(10)] → Power relay [CR-35(86) (87)]
 → Fuse box No.12 → I/conn [CN-2(5)] → Fuel cut-off [CN-79(1)]

Start switch : START

Start switch START[CS-2(5)] → I/conn[CN-8(9)] → Safety relay [CR-5(86) (30)]
 → I/conn [CN-3(2)] → Start relay [CR-23]
 → I/conn [CN-2(4)] → Fuel cut off [CN-79(2)]

2) CHECK POINT

| Engine | Start switch | Check point | Voltage |
|-----------|--------------|-------------------------------------------------------------------------------------------------------------------------------------------------------------------------------------------------------------------------------------------------------|----------|
| Operating | Start | <ul style="list-style-type: none"> - GND (Battery) - GND (Start key) - GND (Battery relay M4) - GND (Starter B +) - GND (Starter M) - GND (Start relay) - GND (Battery relay M8) | 20 ~ 25V |

GND : Ground

STARTING CIRCUIT (TIER I)

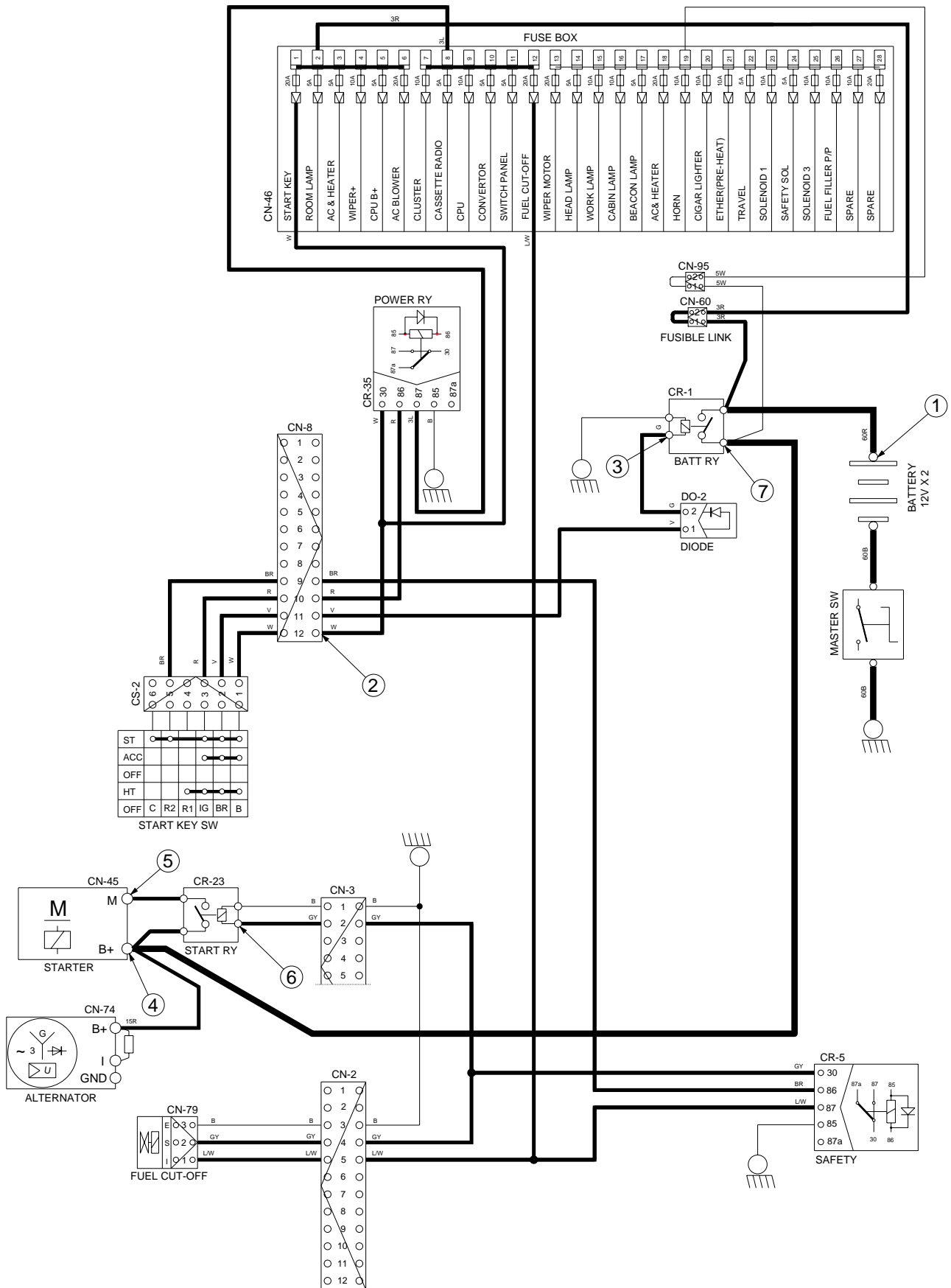

B. TIER II(#1001 AND UP)

1) OPERATING FLOW

Battery(+) terminal → Battery relay[CR-1] → Fusible link → Fuse box No.1
 → I/conn [CN-8(12)] → Start key [CS-2(1)]

Start switch : ON

→ Start switch ON [CS-2(2)] → I/conn [CN-8(11)] → Diode[DO-2] →
 Battery relay [CR-1]:Battery relay operating(All power is supplied with the electric component)
 → Start switch ON [CS-2(3)] → I/conn [CN-8(10)] → Power relay [CR-35(86) (87)]
 → Fuse box No.12 → I/conn [CN-2(5)] → Fuel cut-off [CN-79]

Start switch : START

Start switch START[CS-2(5)] → I/conn[CN-8(9)] → Safety relay [CR-5(86) (30)]
 → I/conn [CN-3(2)] → Start relay [CR-23]

After 10 seconds from the engine starts to run, the anti-restart relay [CN-50(11)] opened, the engine cannot restart.

2) CHECK POINT

| Engine | Start switch | Check point | Voltage |
|-----------|--------------|-------------------------------------------------------------------------------------------------------------------------------------------------------------------------------------------------------------------------------------------------------|----------|
| Operating | Start | <ul style="list-style-type: none"> - GND (Battery) - GND (Start key) - GND (Battery relay M4) - GND (Starter B +) - GND (Starter M) - GND (Start relay) - GND (Battery relay M8) | 20 ~ 25V |

GND : Ground

STARTING CIRCUIT (TIER II)

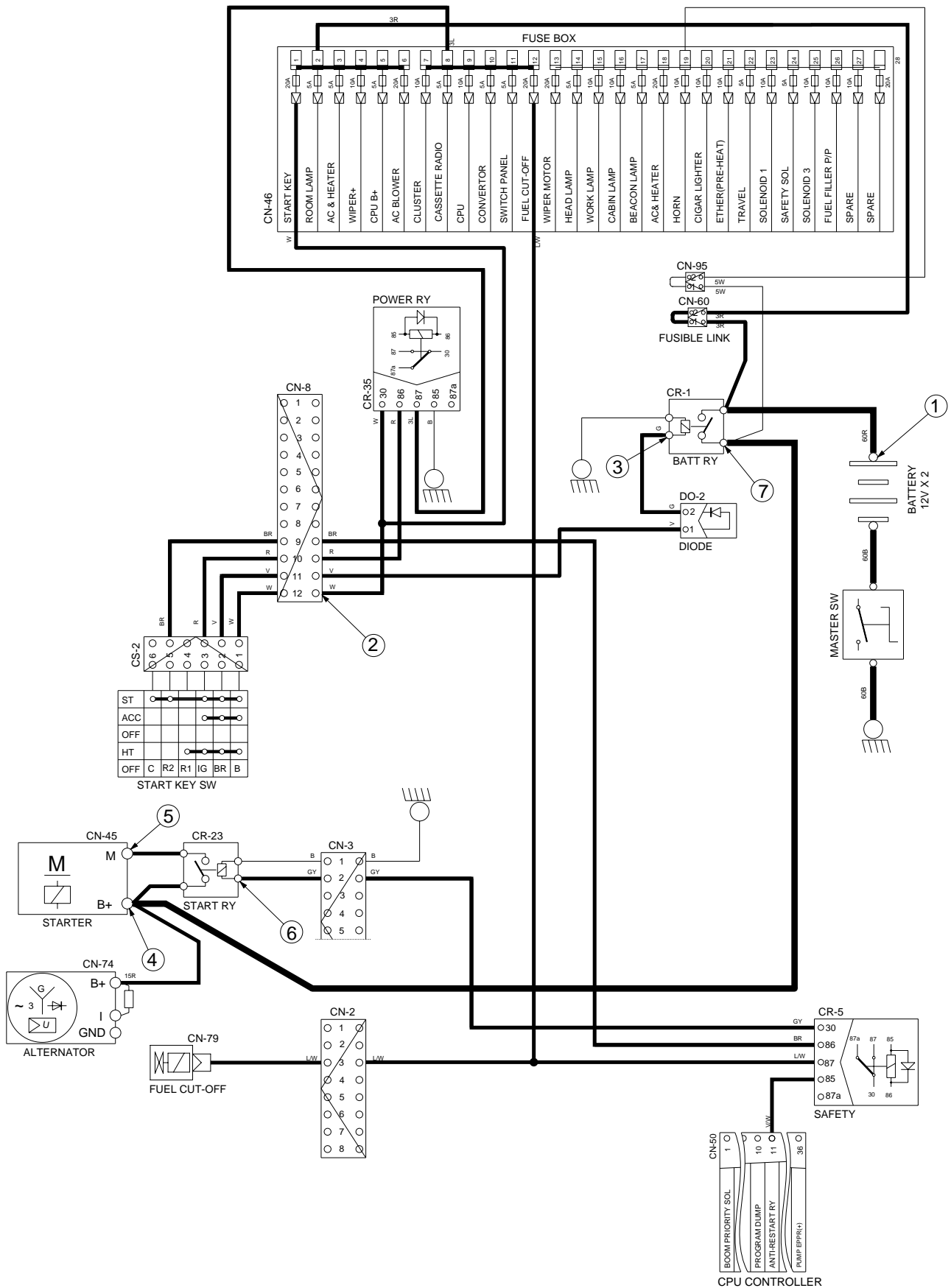

3. CHARGING CIRCUIT

When the starter is activated and the engine is started, the operator releases the key switch to the ON position.

Charging current generated by operating alternator flows into the battery through the Battery relay(CR-1).

The current also flows from alternator to each electrical component and controller through the fuse box.

1) OPERATING FLOW

(1) Warning flow

Alternator " I " terminal → I/conn [CN-3(3)] → CPU Controller [CN-51(9)] → Cluster warning lamp (Via serial interface)

(2) Charging flow

Alternator "B+" terminal → Battery relay → Battery(+) terminal
 → Fusible link → Fuse box

2) CHECK POINT

| Engine | Start switch | Check point | Voltage |
|--------|--------------|-----------------------------------------------------------------------------------------------------------------------------------|---------|
| ON | ON | - GND (Battery voltage) - GND (Battery relay) - GND (Alternator B terminal) - GND (Alternator I terminal) - GND (CPU) | 20~27V |

GND : Ground

CHARGING CIRCUIT

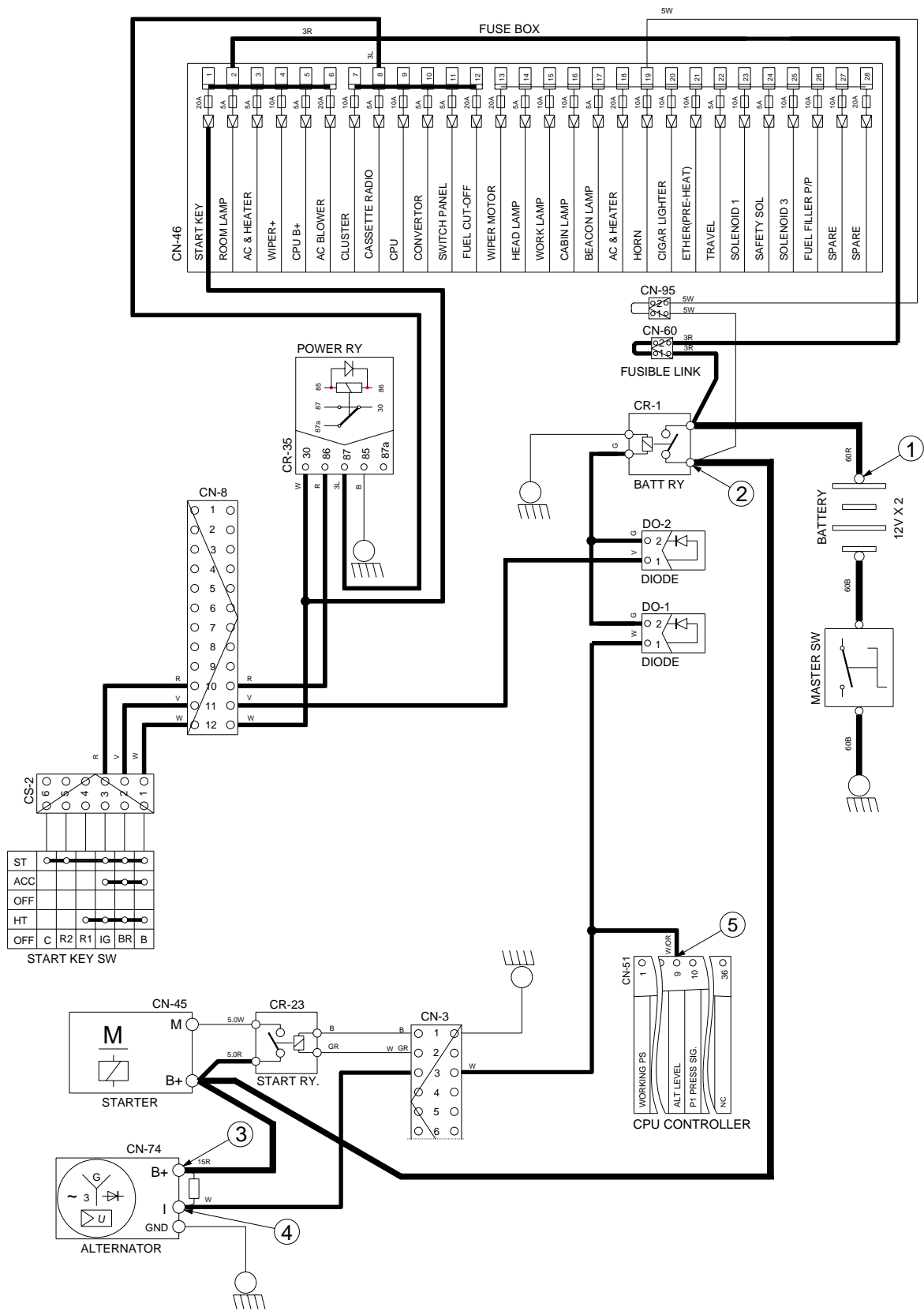

4. HEAD LAMP CIRCUIT

1) OPERATING FLOW

Fuse box (No.14) → I/conn [CN-7(7)] → Switch panel [CN-116(9)]

When lamp switch ON

Switch panel [CN-116(1)] → I/conn [CN-7(1)] →

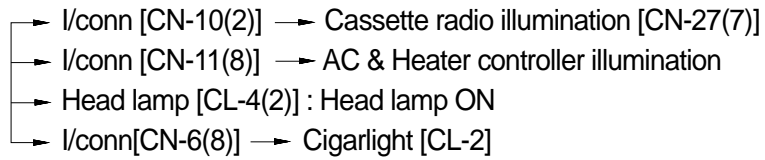

2) CHECK POINT

| Engine | Key switch | Check point | Voltage |
|--------|------------|-------------------------------------------------------------------------------|---------|
| STOP | ON | - GND (Fuse box) - GND (Switch power input) - GND (Switch power output) | 20~25V |

GND : Ground

HEAD LAMP CIRCUIT

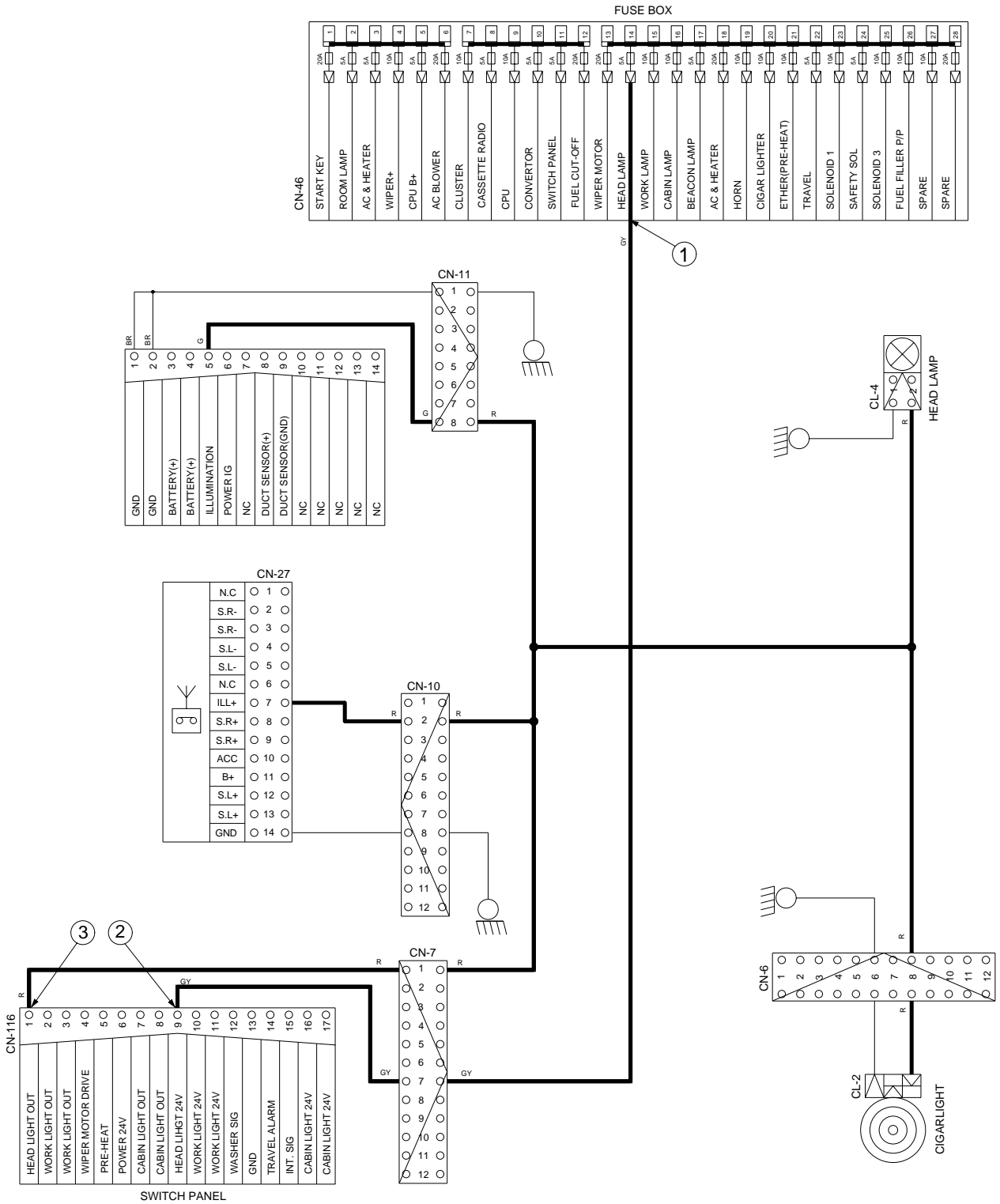

5. WORK LAMP CIRCUIT

1) OPERATING FLOW

Fuse box (No.15) → I/conn [CN-7(8)] → Switch panel [CN-116(10,11)]

When work lamp switch ON

Work lamp switch ON [CS-116(2,3)] → I/conn [CN-7(2)] → I/conn [CN-12(1)]

→ Work lamp ON [CL-5(2), CL-6(2)]

2) CHECK POINT

| Engine | Key switch | Check point | Voltage |
|--------|------------|----------------------------------------------------------------------------------------------------|---------|
| STOP | ON | - GND (Fuse box) - GND (Switch power input) - GND (Switch power output) - GND (Work lamp) | 20~25V |

GND : Ground

WORK LAMP CIRCUIT

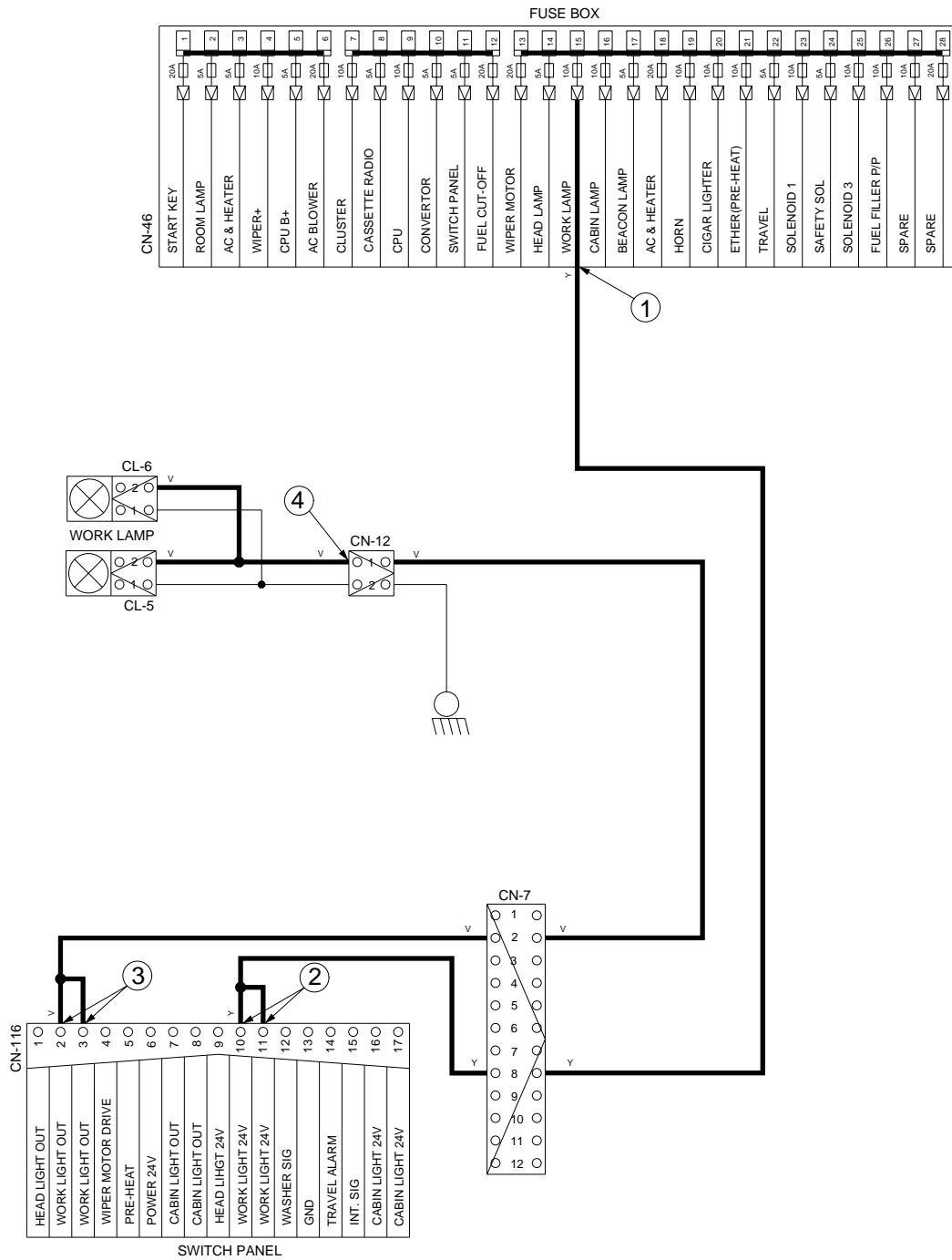

6. CAB LAMP CIRCUIT

1) OPERATING FLOW

Fuse box (No.16) → I/conn [CN-7(12)] → Switch panel [CN-116(16,17)]

When Lamp switch ON

Lamp switch ON [CN-116(7, 8)] → I/conn [CN-7(6)] → I/conn [CN-10(11)] →
Cab light ON [CL-8(2), CL-9(2)]

2) CHECK POINT

| Engine | Start switch | Check point | Voltage |
|--------|--------------|-----------------------------------------------------------------------------------------------------------|----------|
| STOP | ON | ① - GND (Fuse box) ② - GND (Switch power input) ③ - GND (Switch power output) ④ - GND (Cab lamp) | 20 ~ 25V |

GND : Ground

CAB LAMP CIRCUIT

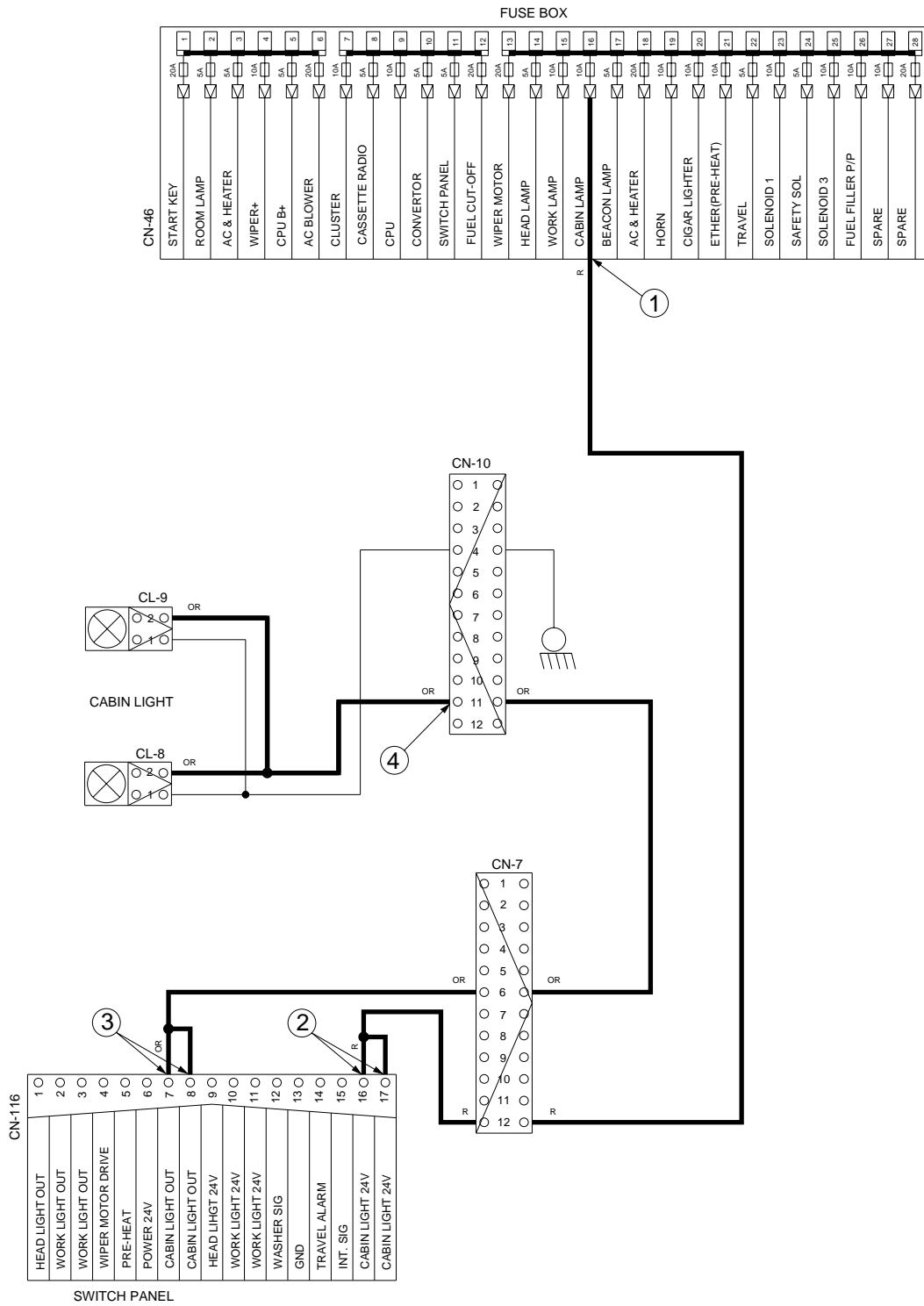

7. BEACON LAMP CIRCUIT

1) OPERATING FLOW

Fuse box (No.17) → I/conn [CN-8(3)] → Beacon lamp switch [CS-23(6)]

When lamp switch ON

Beacon lamp switch ON [CS-23(2)] → Switch Indicator lamp ON [CS-23(9)]
→ I/conn [CN-8(4)] → I/conn [CN-10(10)]
→ Beacon lamp ON [CL-7]

2) CHECK POINT

| Engine | Start switch | Check point | Voltage |
|--------|--------------|--------------------------------------------------------------------------------------------------|---------|
| STOP | ON | - GND(Fuse box) - GND(Switch power input) - GND(Switch power output) - GND(Beacon lamp) | 20~25V |

GND : Ground

BEACON LAMP CIRCUIT

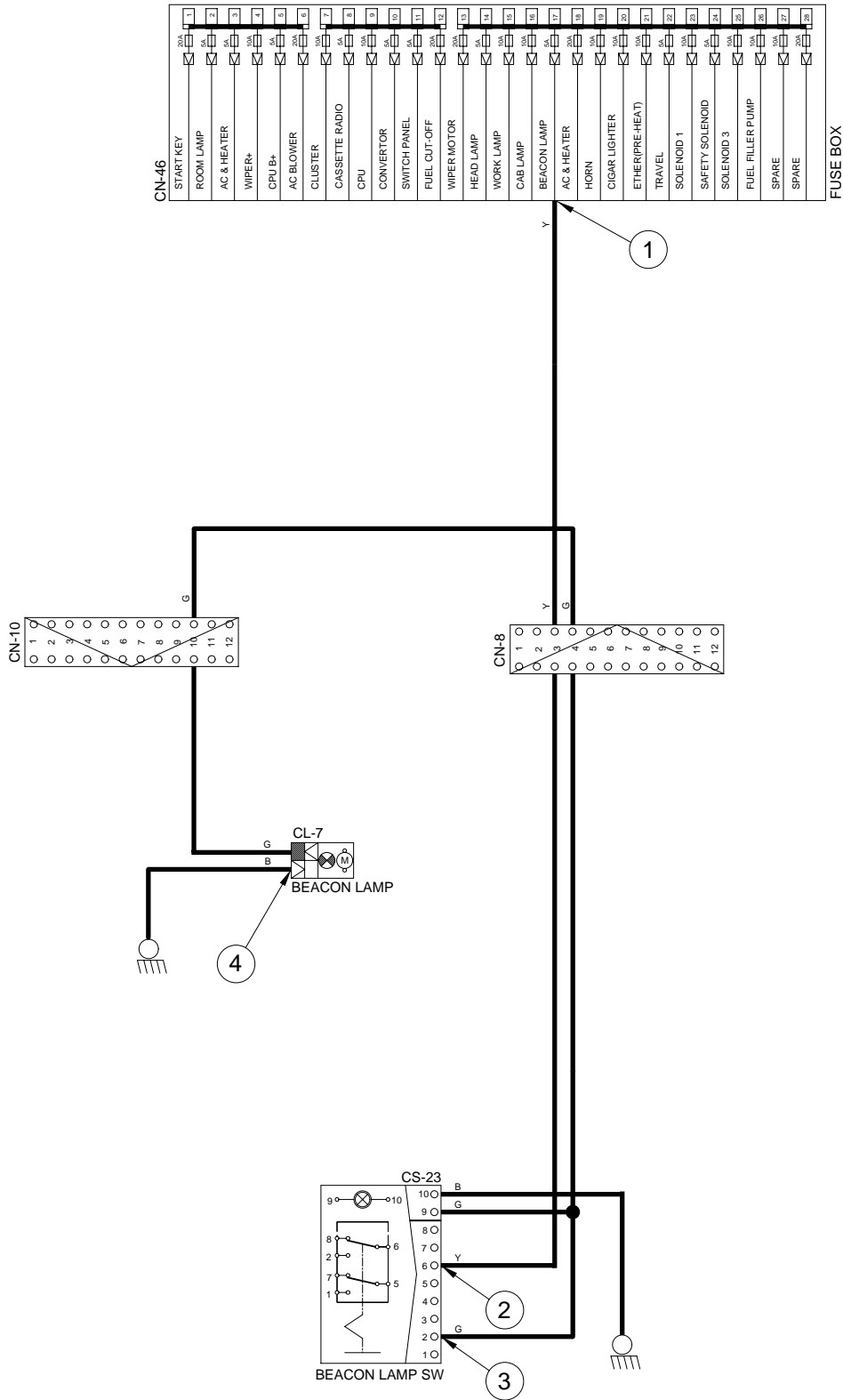

WASHER CONTROL CIRCUIT

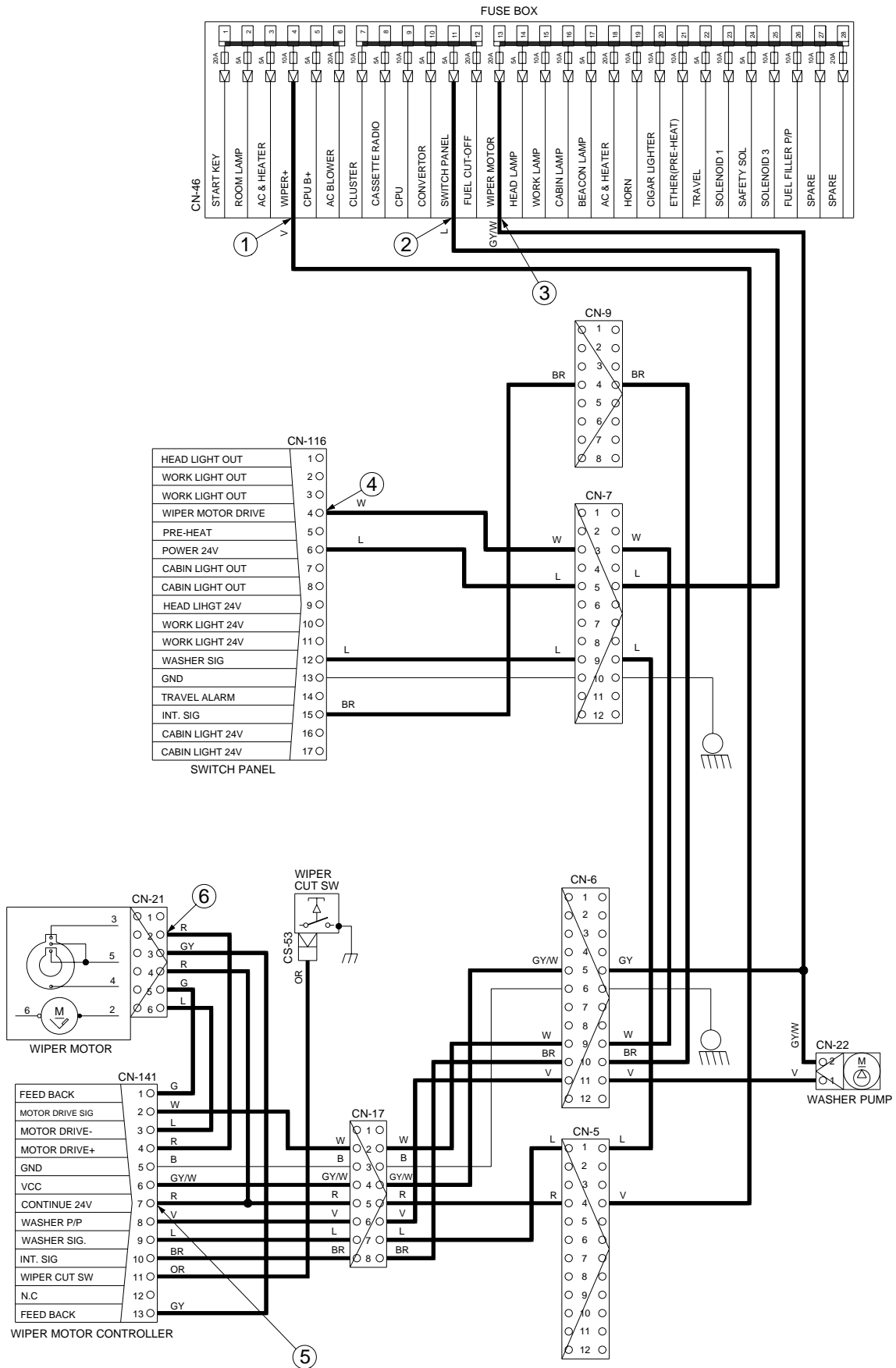

CONTROLLER CIRCUIT

A. TIER I (UP TO #1000)

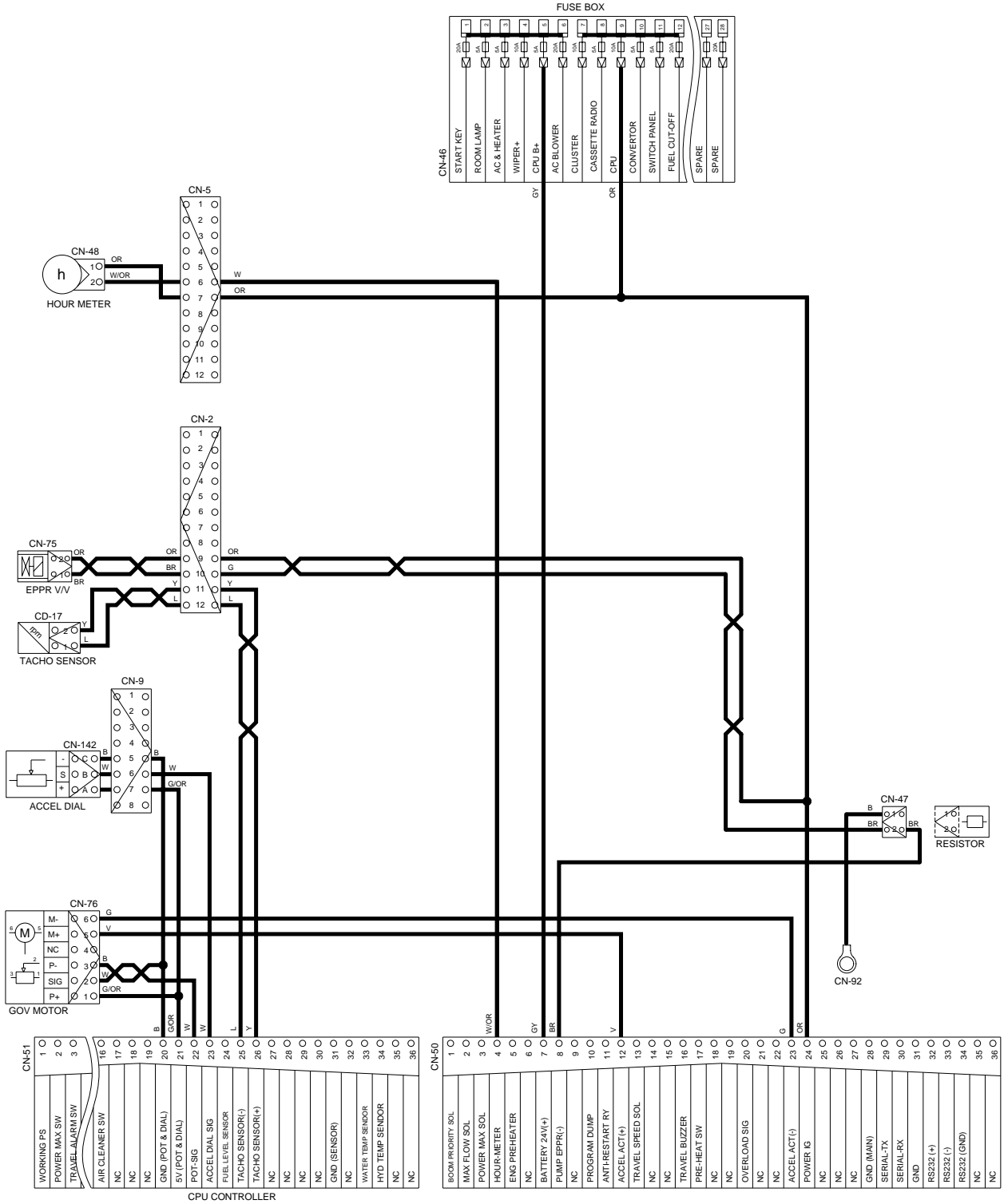

B. TIER II (#1001 AND UP)

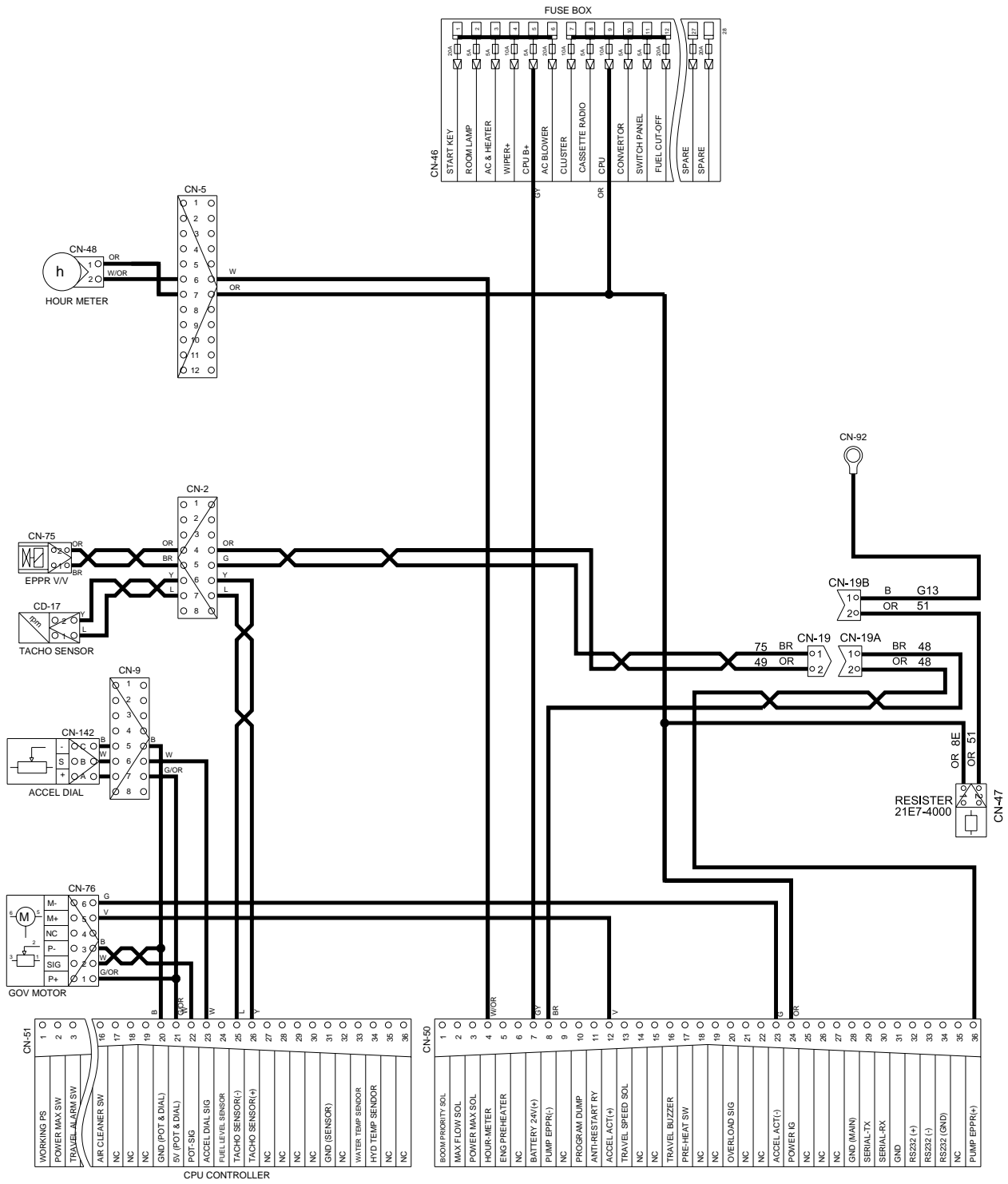

MONITORING CIRCUIT

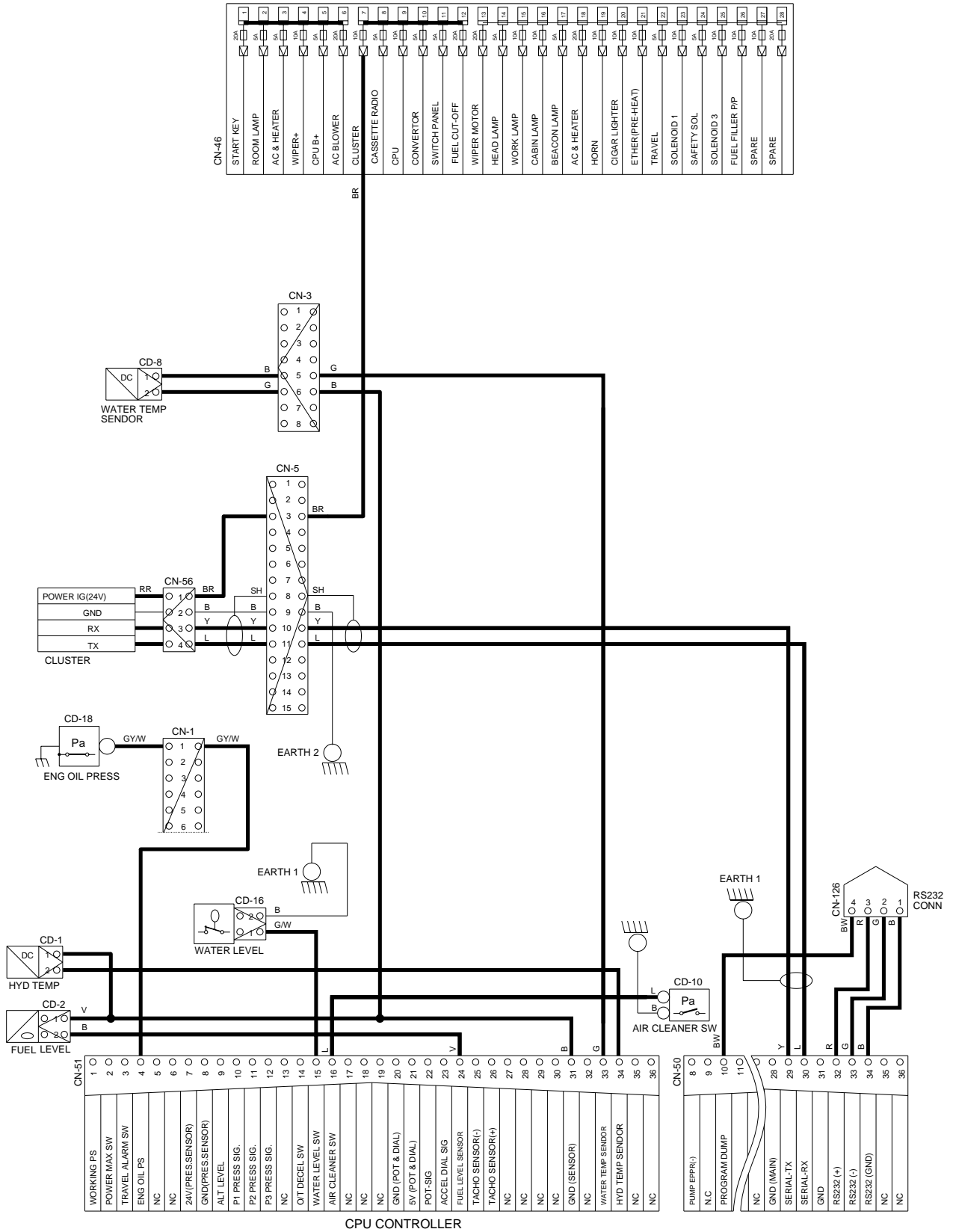

ELECTRIC CIRCUIT FOR HYDRAULIC

