

GROUP 3 PILOT CIRCUIT

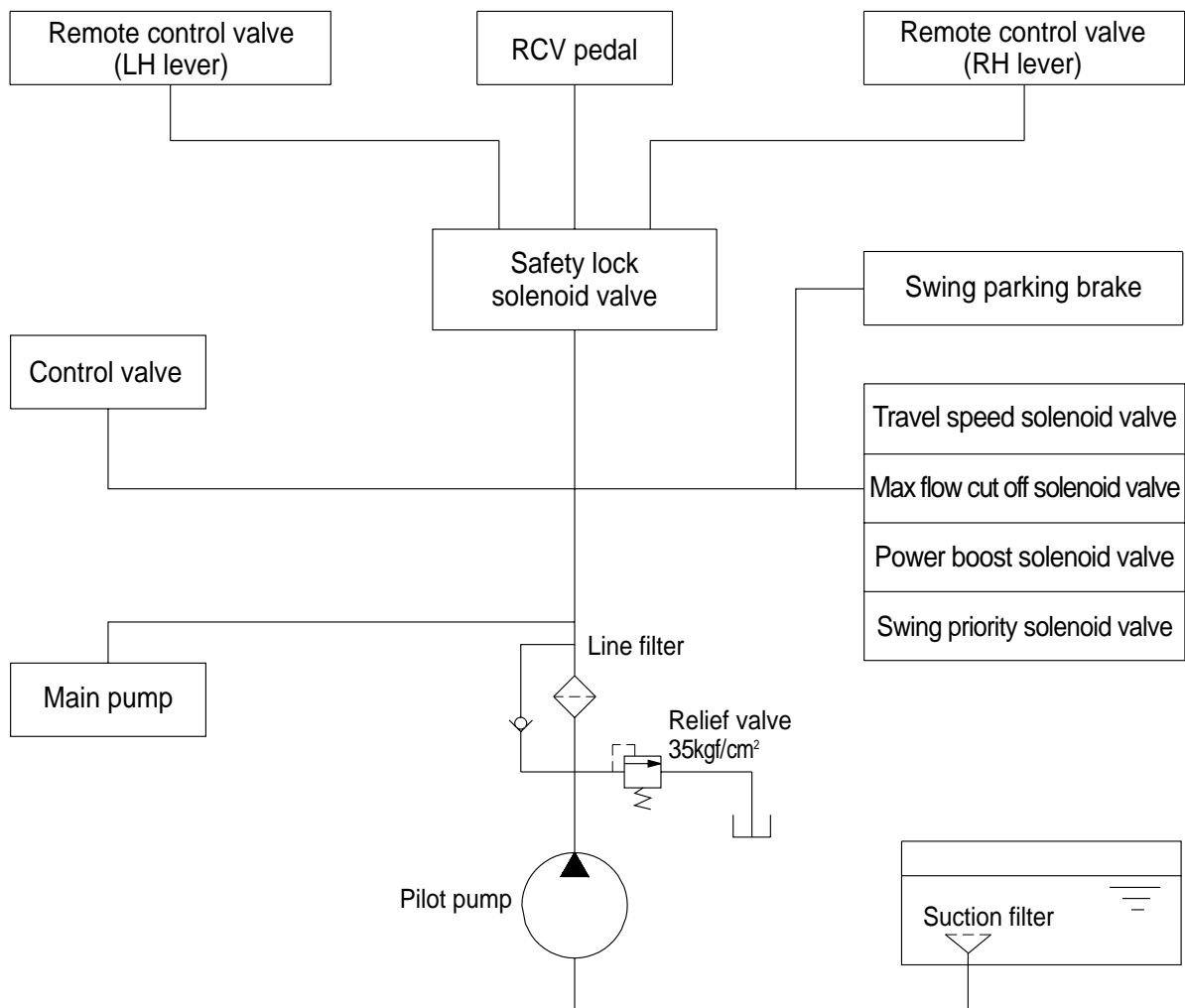

The pilot circuit consists of suction circuit, delivery circuit and return circuit.

The pilot pump is provided with relief valve, receives the oil from the hydraulic tank through the suction filter.

The discharged oil from the pilot pump flows to the remote control valve through line filter, EPPR valve, solenoid valve assemblies, swing parking brake, main control valve and safety lock solenoid valve.

1. SUCTION, DELIVERY AND RETURN CIRCUIT

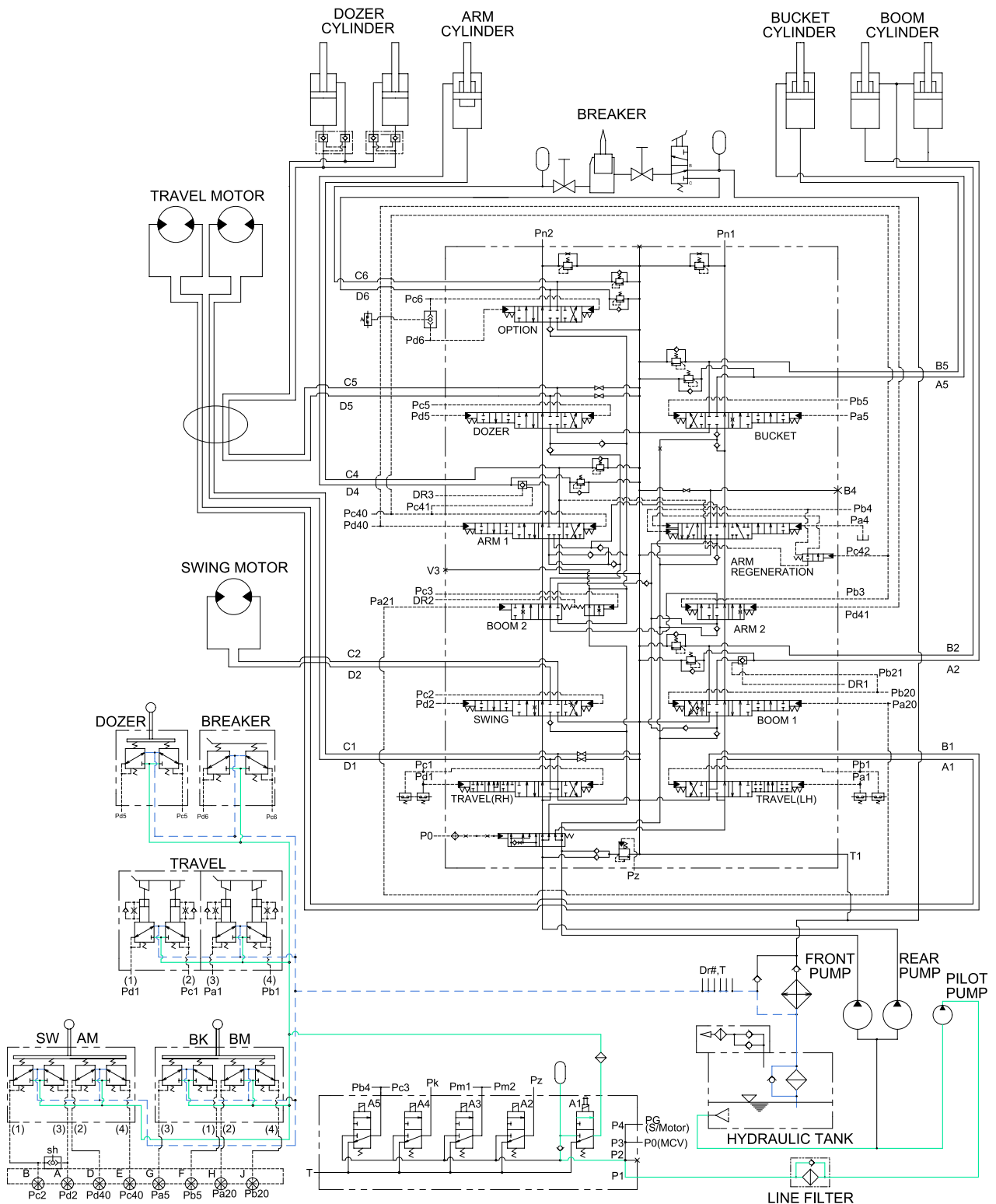

The pilot pump receive oil from the hydraulic tank. The discharged oil from the pilot pump flows to the safety solenoid valve through the line filter. The oil is filtered by the line filter. The pilot relief valve is provided in the pilot pump for limiting the pilot circuit pressure. The oil filtered by line filter flows remote control valve through safety solenoid valve. The return oil flow into the hydraulic tank.

2. SAFETY VALVE(SAFETY LEVER)

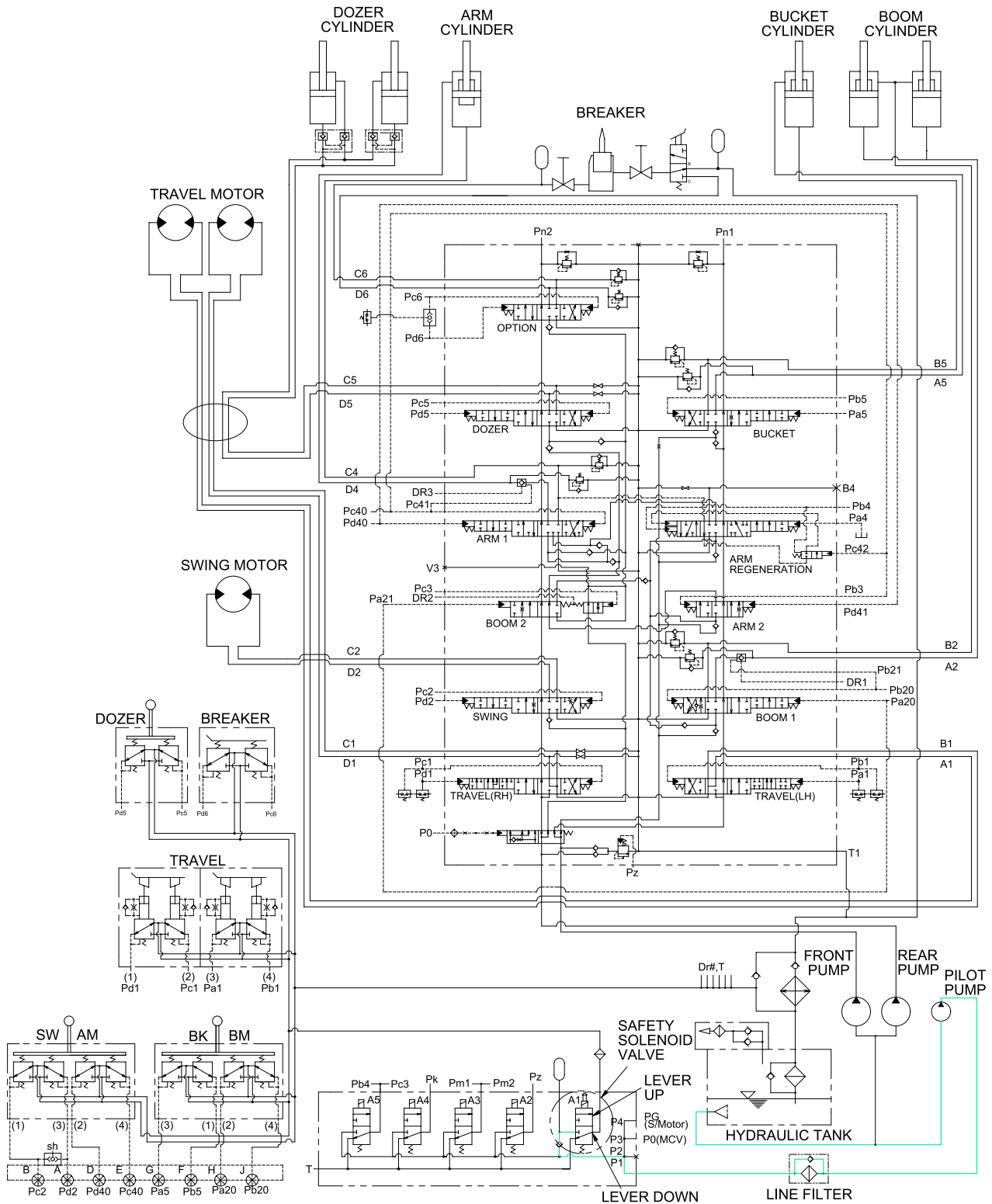

When the lever of the safety solenoid valve is moved upward, oil flows into the remote control valve through solenoid valve and line filter.

When the lever of the safety solenoid valve is moved downward, oil does not flow into the remote control valve, because of the blocked port.

3. SWING PRIORITY SYSTEM

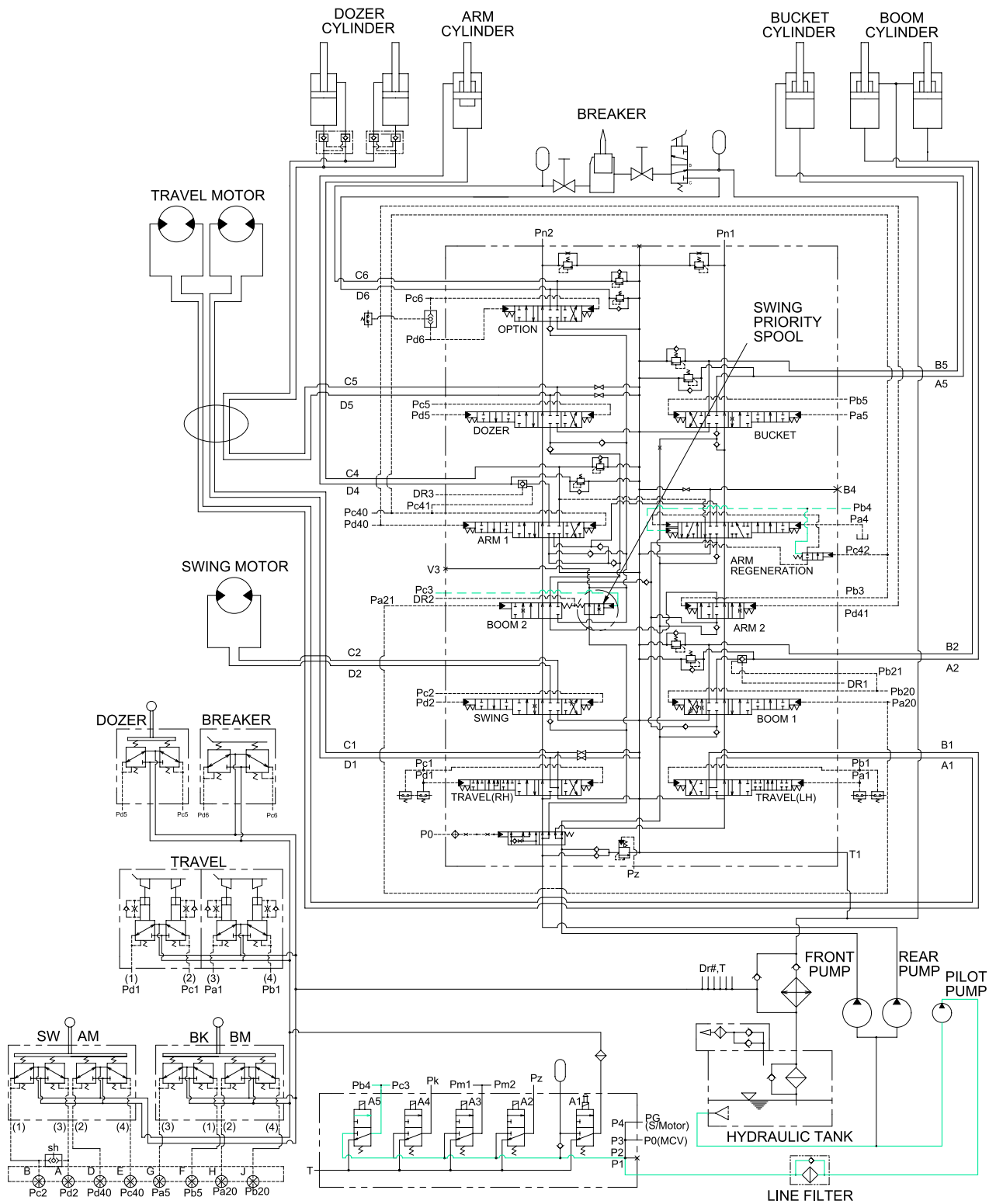

When carrying out the combined operation of swing and boom or arm of the left control valve, the swing speed can be lowered than operating speed of boom or arm. To prevent it, swing priority spool is used. Pc3 pressure from solenoid valve shifts the swing priority spool to the left and decreases the oil flow rate to the boom or arm section by orifice. This is called the swing priority system.

4. TRAVEL SPEED CONTROL SYSTEM

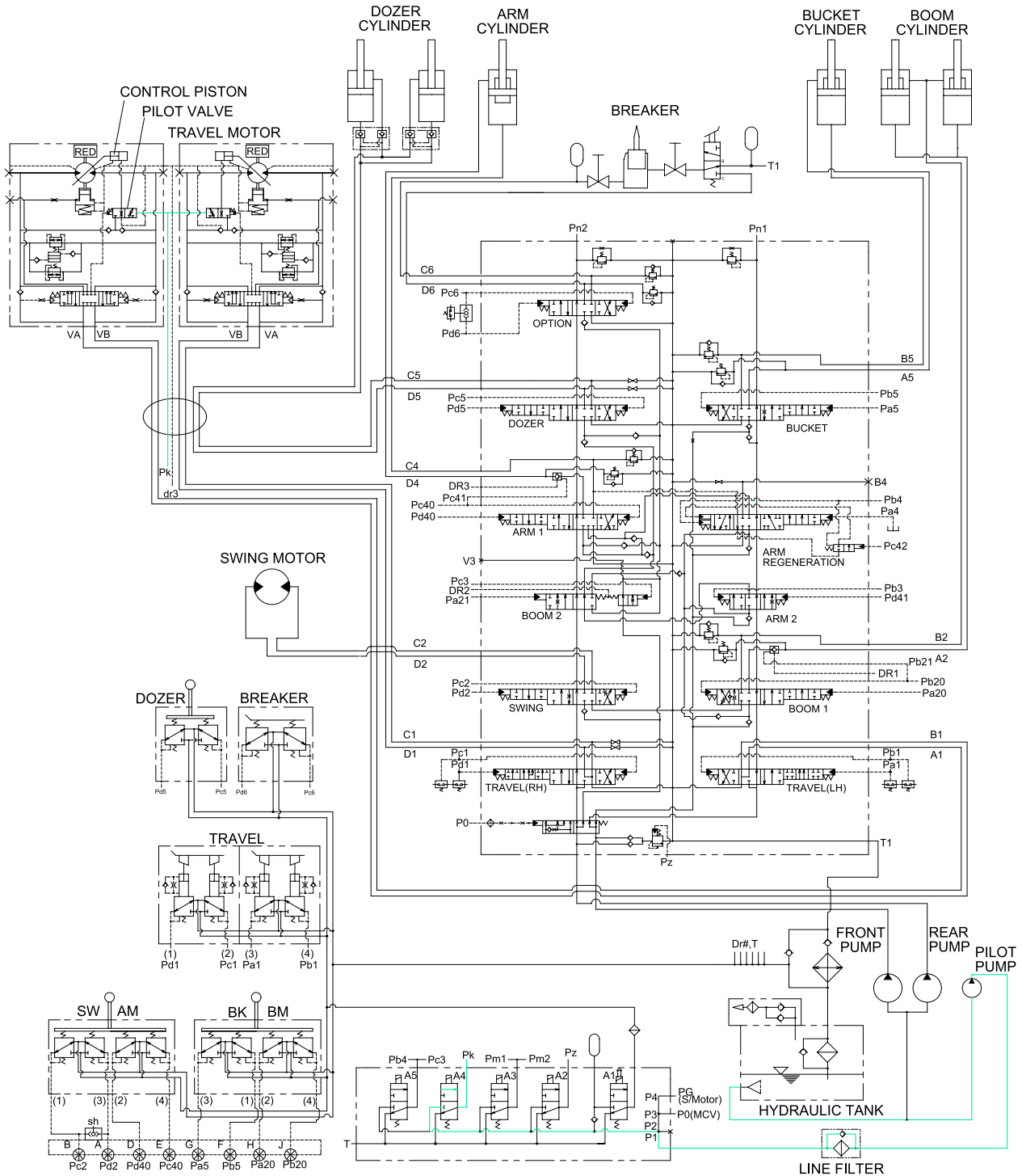

When the travel speed switch is pushed, the travel speed solenoid valve is actuated and the discharged oil from the pilot pump flows to the Pk port of pilot valve in the travel motors. As a result, the control piston is pushed by the main oil flow, thus the displacement is minimized. When the travel speed switch is pushed once more, the travel speed solenoid valve is return to original position by the force of spring, the hydraulic oil of Pk port returns to the hydraulic tank. As a result, the control piston is returned by the main oil flow, thus the displacement is maximized.

5. MAIN RELIEF PRESSURE CHANGE SYSTEM

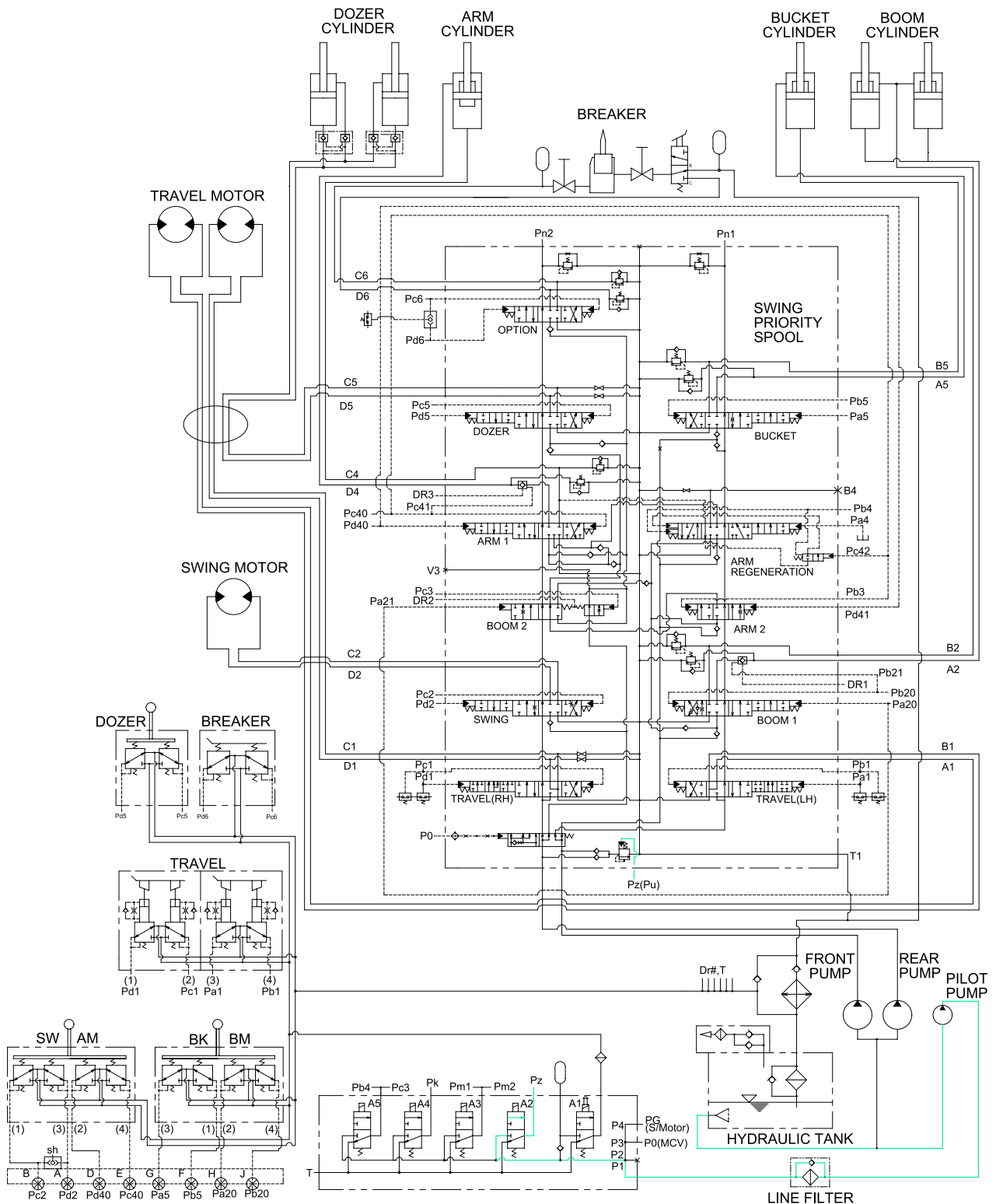

When the power boost switch on the left control lever is pushed ON, the power boost solenoid valve is actuated, the discharged oil from the pilot pump flows into Pz port of the main relief valve of main control valve; then the setting pressure of the main relief valve is raised from 330kgf/cm² to 360kgf/cm² for increasing the digging power. And even when pressed continuously, it is canceled after 8 seconds.

6. MAX FLOW CUT OFF SYSTEM

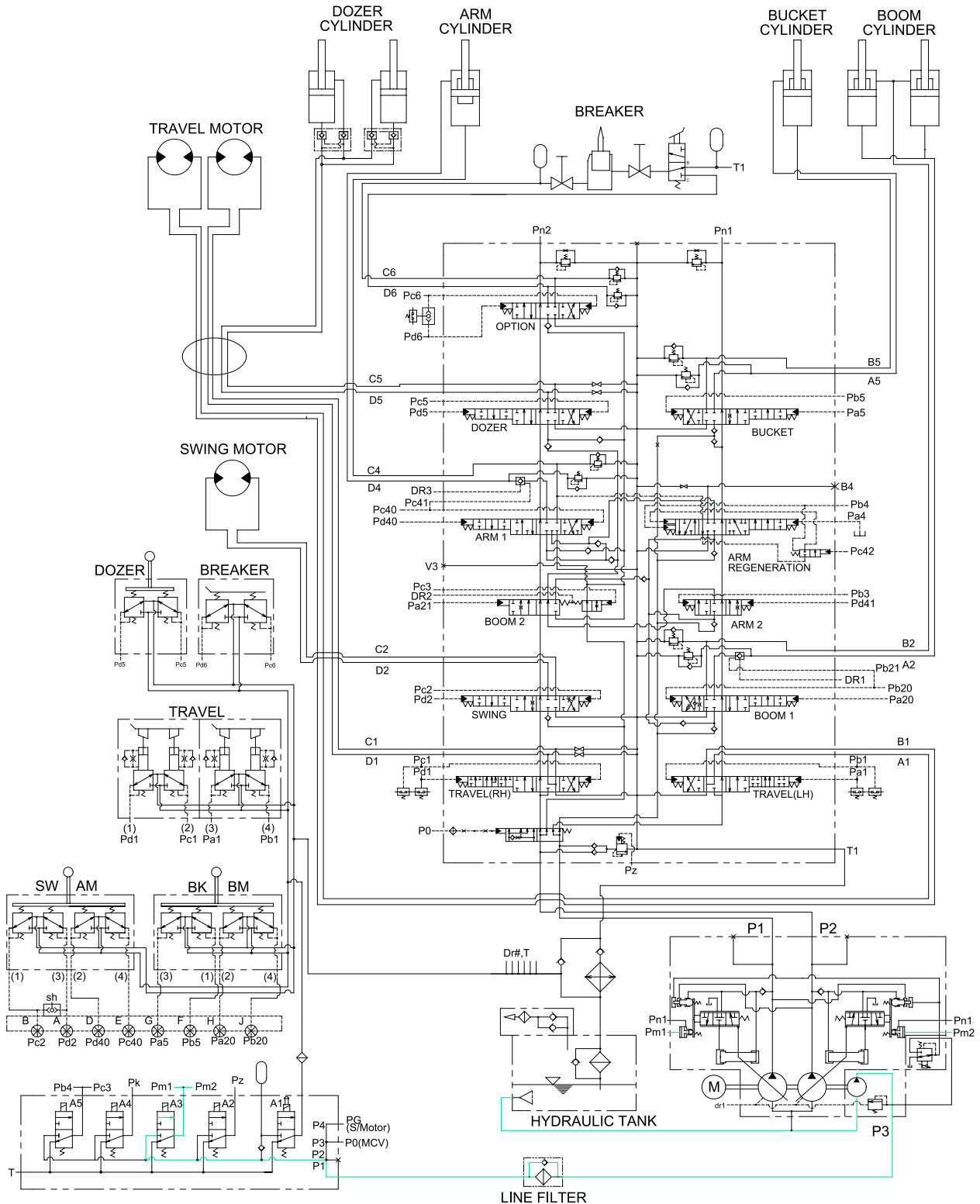

When the breaker operation mode is selected on the cluster, max flow cut off solenoid valve actuates automatically.

Thus pilot pressure(Pm1,2) is sent to the regulator and pump discharge volume is decreased.

7. SWING PARKING BRAKE RELEASE

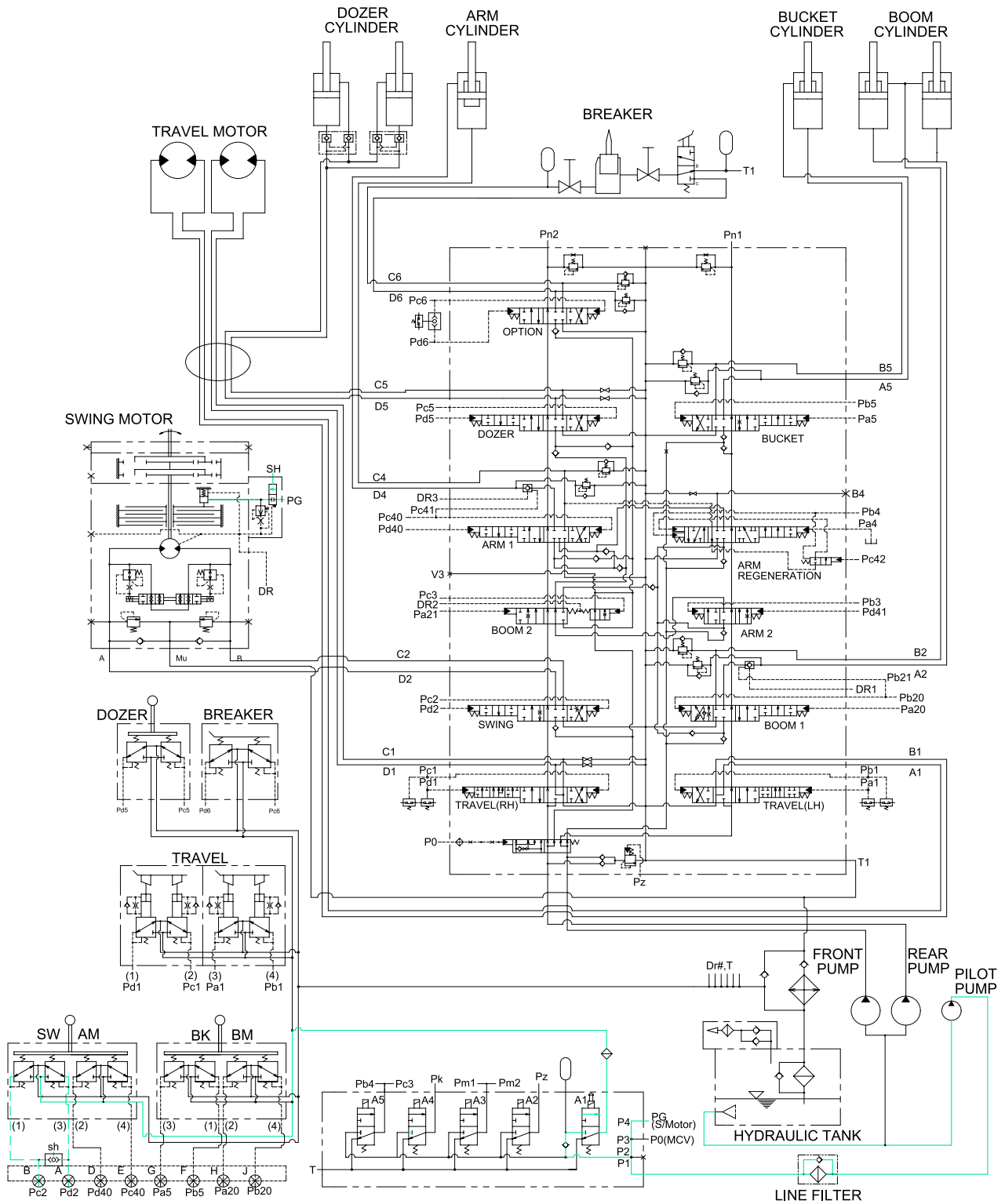

When the swing control lever is tilted, the pilot oil flow into SH port of shuttle valve, this pressure move spool so, discharged oil from pilot valve flow into PG port.

This pressure is applied to swing motor disc, thus the brake is released.

When the swing control lever is set in the neutral position, oil in the swing motor disc cylinder is drained, thus the brake is applied.