

GROUP 4 TRAVEL DEVICE

1. CONSTRUCTION

Travel device consists travel motor and gear box.

Travel motor includes brake valve, parking brake and high/low speed changeover mechanism.

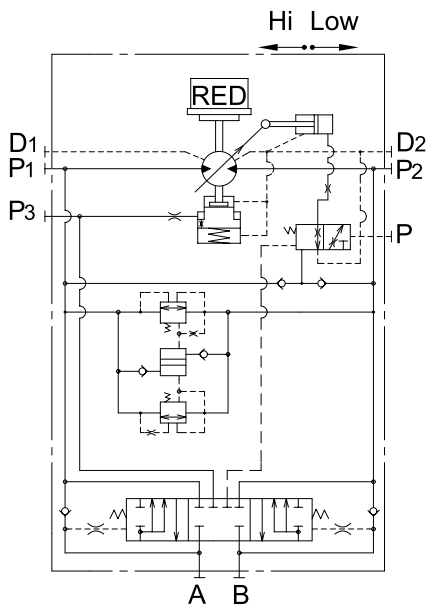
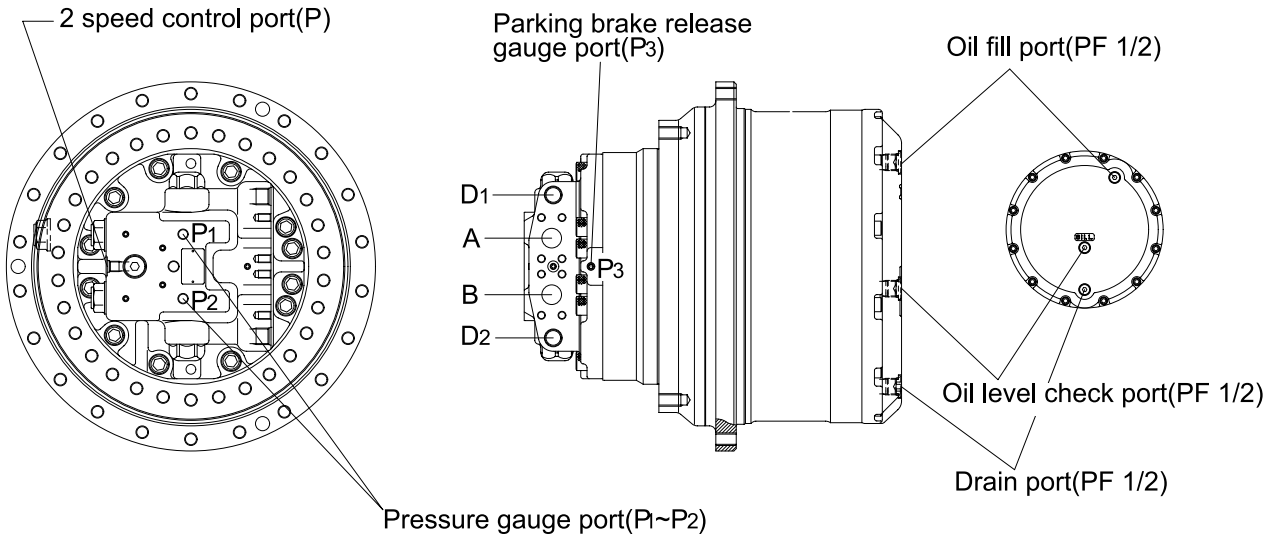

Port	Port name	Port size
A	Main port	SAE 5000psi 1"
B	Main port	SAE 5000psi 1"
P1, P2	Gauge port	PT 1/4
P3	Gauge port	PT 1/8
D1, D2	Drain port	PF 1/2
P	2 speed control port	PF 1/4

1) BASIC STRUCTURE

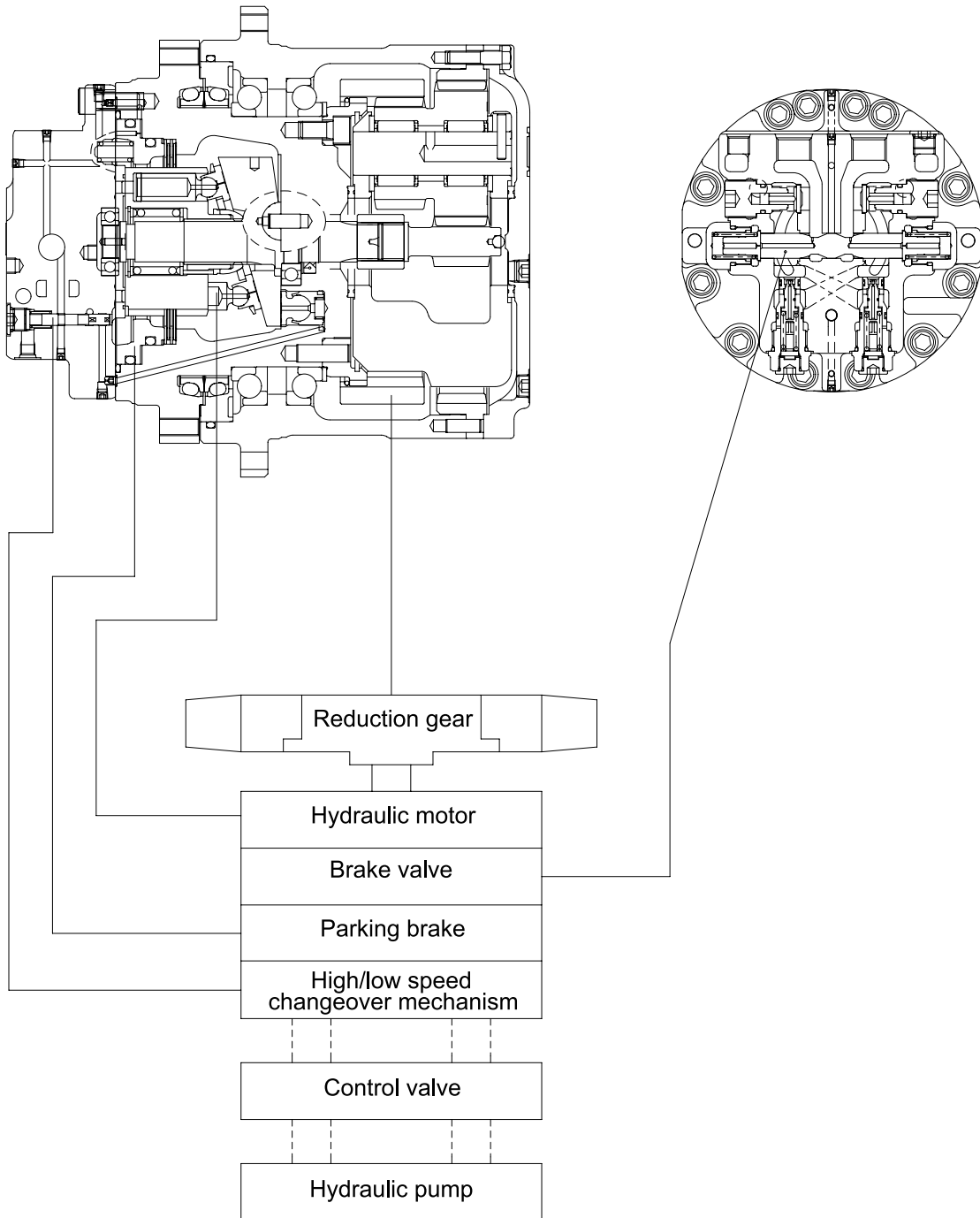

2) STRUCTURE

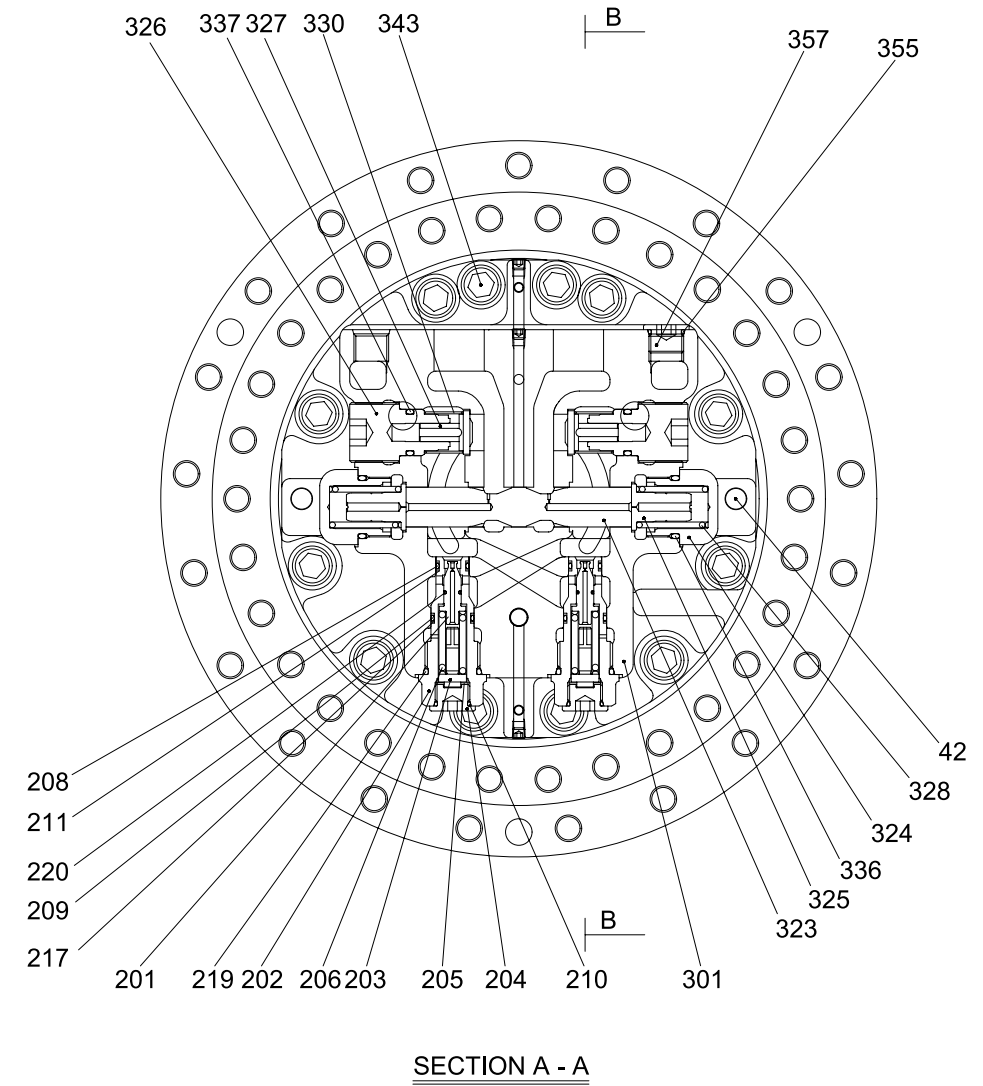
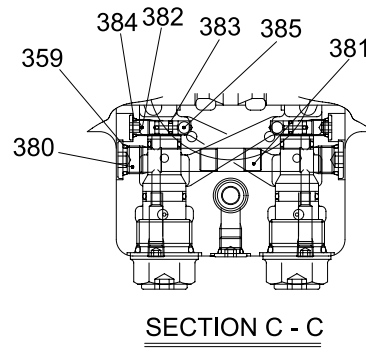
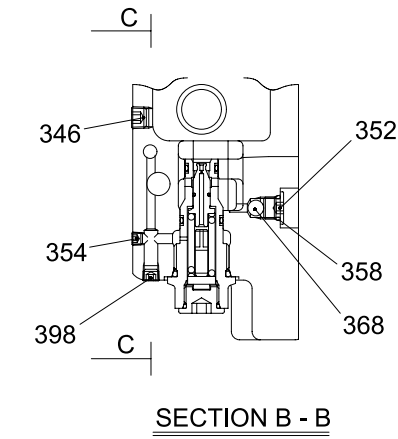
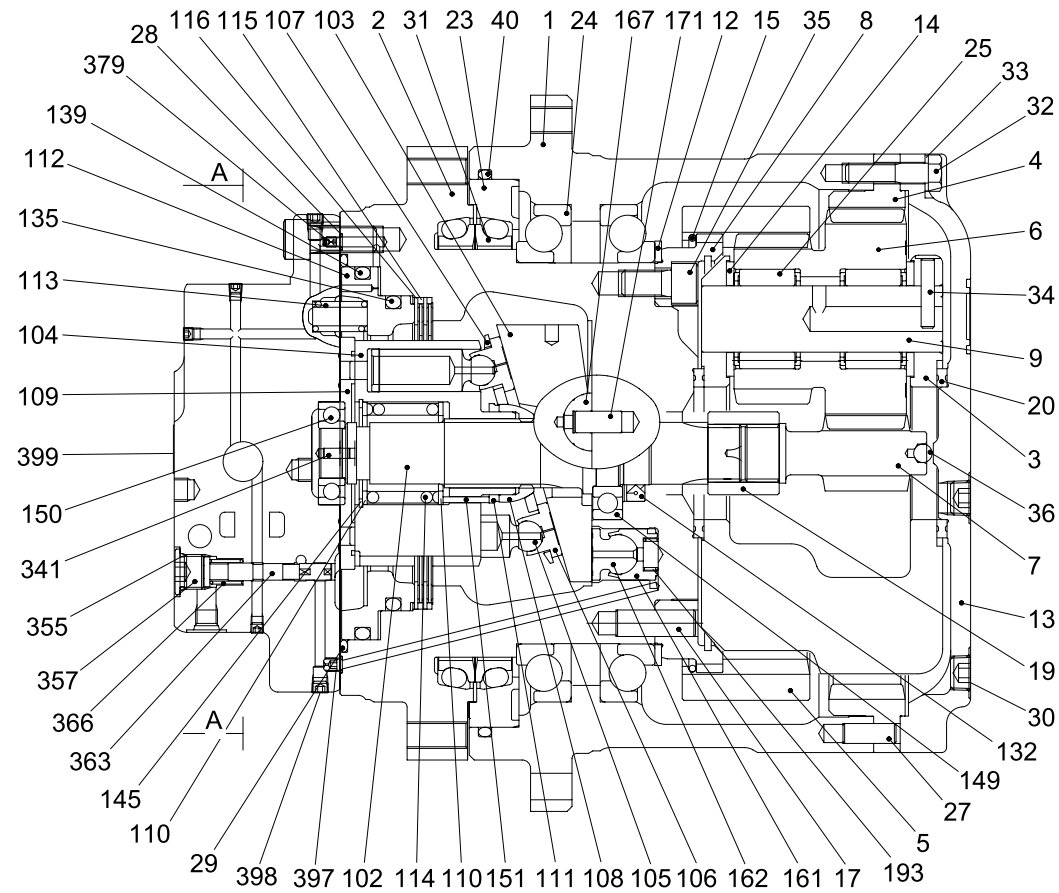

1 Hub	25 Needle bearing	106 Shoe	151 Rolling	219 O-ring	355 O-ring
2 Spindle	27 Parallel pin	107 Retainer plate	161 Piston(2)	220 Piston seal	357 RO plug
3 Carrier	28 O-ring	108 Thrust ball	162 Shoe(2)	301 Rear flange	358 O-ring
4 Ring gear A	29 O-ring	109 Timing plate	167 Pivot	323 Spool	359 O-ring
5 Ring gear B	30 PT plug	110 Washer	171 Paralell pin	324 Plug	363 Spool(2)
6 Cluster gear	31 Floating seal	111 Collar	193 Spring	325 Stopper	366 Spring
7 Sun gear	32 Socket bolt	112 Piston	201 Valve	326 Plug	368 Steel ball
8 Coupling gear	33 Spring washer	113 Spring	202 Sleeve	327 Valve	379 Filter
9 Shaft(cluster)	34 Parallel pin	114 Spring	203 Spring retainer	328 Spring	380 Plug
12 Distance piece	35 Socket bolt	115 Friction plate	204 Plug	330 Spring	381 Piston
13 Cover	36 Steel ball	116 Mating plate	205 Shim	336 O-ring	382 Plug
14 Thrust collar	40 O-ring	132 Oil seal	206 Spring	337 O-ring	383 O-ring
15 Ring	42 Parallel pin	135 O-ring	208 O-ring	341 Parallel pin	384 O-ring
17 Pin	102 Main shaft	139 O-ring	209 O-ring	343 Socket bolt	385 Steel ball
19 Coupling	103 Swash plate	145 Snap ring	210 O-ring	346 PT plug	397 Orifice
20 Thrust plate	104 Cylinder block	149 Ball bearing	211 Back-up ring	352 RO plug	398 PT plug
23 Seal ring	105 Piston	150 Ball bearing	217 Back-up ring	354 PT plug	399 Name plate
24 Ball bearing					

2. FUNCTION

1) HYDRAULIC MOTOR

(1) Rotary group

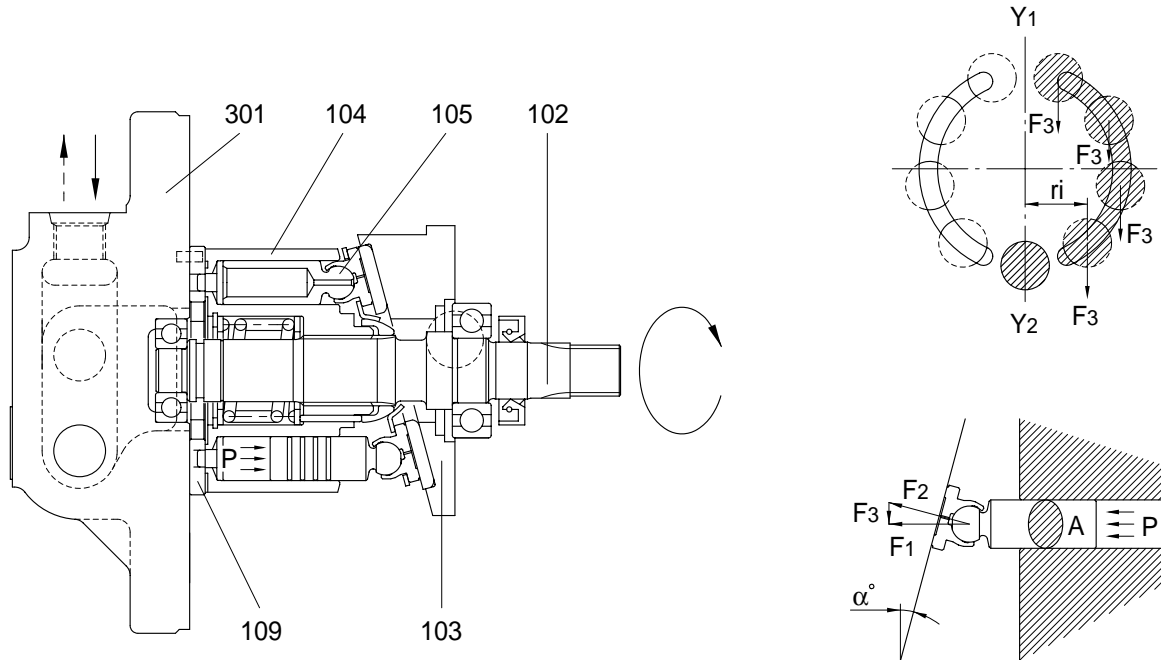

The pressurized oil delivered from the hydraulic pump flows to rear flange(301) of the motor, passes through the brake valve mechanism, and is introduced into cylinder block(104) via timing plate(109). This oil constructively introduced only to one side of Y1-Y2 connecting the upper and lower dead points of stroke of piston(105). The pressurized oil fed to one side in cylinder block(104) pushes each piston(105, four or five) and generates a force($F \text{ kg} = P \text{ kg/cm}^2 \times A \text{ cm}^2$). This force acts on swash plate(103), and is resolved into components (F2 and F3) because swash plate(103) is fixed at an angle(α°) with the axis of drive shaft(102). Radial component(F3) generates respective torques($T = F3 \times ri$) for Y1-Y2. This residual of torque($T = F3 \times ri$) rotates cylinder block(104) via piston(105). Cylinder block(104) is spline-coupled with drive shaft(102). So the drive shaft(102) rotates and the torque is transmitted.

(2) Brake valve

Brake released(Starting / Running)

When the pressurized oil supplied from port **P**, the oil opens valve(327) and flows into port **D** at the suction side of hydraulic motor to rotate motor. At the same time, the pressurized oil passes through pipe line **E** from a small hole in spool(323) and flows into chamber **C**. The oil acts on the end face of spool(323) which is put in neutral position by the force of spring(328), thus causing spool(323) to slide to the left. When spool(323) slides, port **C** on the passage at the return side of hydraulic motor, which is closed by the spool groove during stoppage, connected with port **A** at the tank side and the return oil from the hydraulic motor runs into the tank. In consequence, the hydraulic motor rotates. Moreover, sliding of spool(323) causes the pressurized oil to flow into ports **B** and **a**.

The pressurized oil admitted into port **B** activates piston(112) of the parking brake to release the parking brake force. (For details, refer to description of the parking brake.) When the pressurized oil is supplied from port **P**, spool(323) move reversely and the hydraulic motor also rotates reversely.

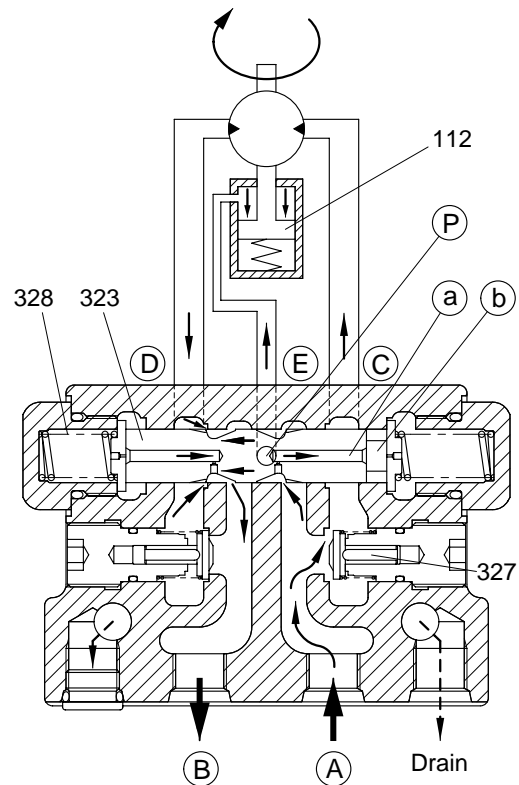

Brake applied(Stopping / Stalling)

When the pressurized oil supplied from port is stopped during traveling, no hydraulic pressure is applied and spool(323) which has slid to the left will return on the right(Neutral) via stopper (325) by the force of spring(328).

At the same time, the hydraulic motor will rotate by the inertia even if the pressurized oil stopped, so the port D of the motor will become high pressure.

This pressurized oil goes from chamber to chamber through the left-hand valve(201).

When the oil enters chamber , the piston(381) slides to the right so as not to rise the pressure, as shown in the figure. Meanwhile, the left-hand valve(201) is pushed open by the pressurized oil in port D.

Therefore, the pressurized oil in port D flows to port C at a relatively low pressure, controlling the pressure in port D and preventing cavitation in port C.

When the piston(381) reaches the stroke end, the pressure in chamber and increase and the left-hand valve(201) closes again, allowing the oil pressure in port D to increase further. Then, the right-hand valve(201) opens port C with pressure higher than that machine relief set pressure.

In this way, by controlling the pressure in port D in two steps, the hydraulic motor is smoothly braked and brought to a stop.

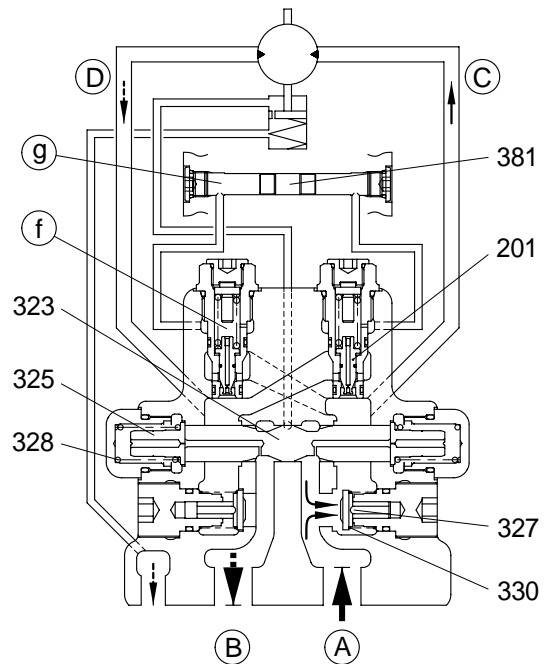

Braking effect on downhill travel

If the machine traveling downhill with a relatively small supply of high pressure oil to its travel motors should start coasting, the same braking effect as the one described above would automatically occur.

In the coasting condition, the motor is driven, instead of driving the track, from the ground and sucks high pressure oil in.

In other words, the motor tends to draw more high pressure oil than is being supplied.

Under this condition, port A goes negative to pull oil out of chamber through oil way , moving back the spool(323) rather rapidly.

The clearance on the left then becomes smaller to throttle the outgoing oil more than before, thereby obstructing the pumping action of the motor.

As in stopping the machine, pressure will build up in port D to make it harder to drive the motor from the ground: This is the braking action.

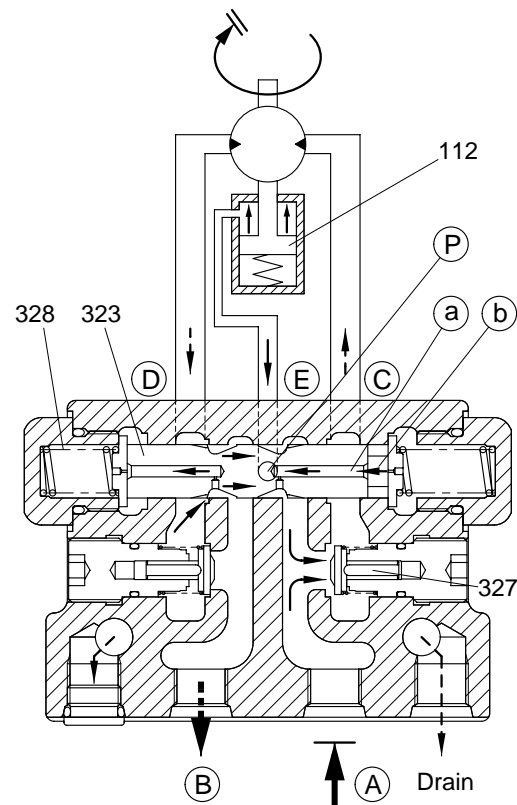

(3) Parking brake

Running

When the pressurized oil is supplied from the brake valve, the spool of brake valve in the hydraulic motor assembly actuates to open the passage to the parking brake and the pressurized oil is introduced into cylinder chamber which is composed of the spindle of reduction gear assembly and piston(112). When the hydraulic pressure reaches 6kgf/cm^2 (0.59Mpa) or more, it overcomes the force of spring (113) and shifts piston(112). With shift of piston(112), no pressing force is applied to mating plate(116) and friction plate (115) and the movement of friction plate (115) becomes free, whereby the brake force to the cylinder in the hydraulic motor assembly is released.

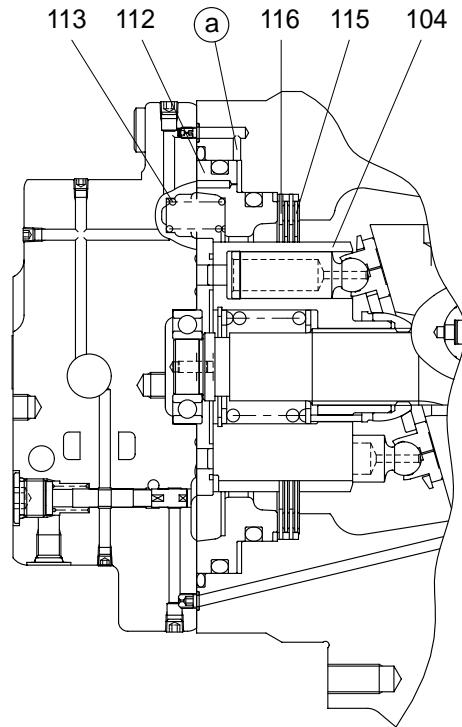

Stopping

When the pressurized oil from the brake valve is shut off and the pressure in cylinder chamber drops 6kgf/cm^2 (0.59Mpa) or less, piston(112) will return by the force of spring(113).

Piston(112) is pushed by this force of spring(113), and mating plate(116) and friction plate(115) in free condition are pressed against the spindle of reduction gear assembly.

The friction force produced by this pressing stops rotation of the cylinder block(104) and gives a braking torque $40.6\text{kgf} \cdot \text{m}$ ($398\text{N} \cdot \text{m}$) to the hydraulic motor shaft.

Note that oil control through a proper oil passage ensures smooth operation.

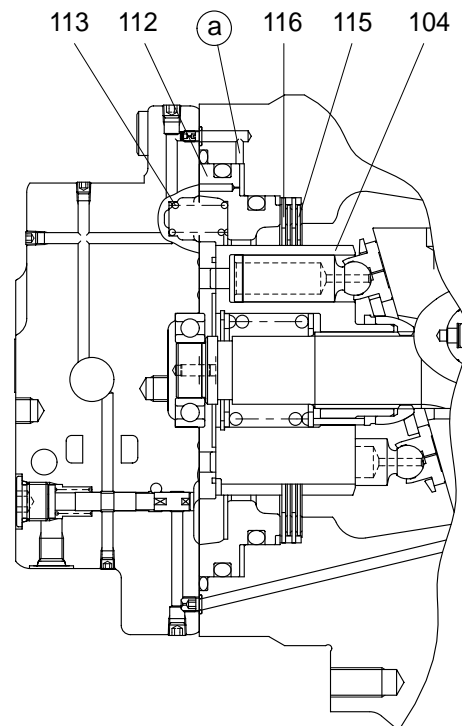

(4) High/low speed changeover mechanism

At low speed - At pilot pressure of less than 20kgf/cm²(1.96Mpa)

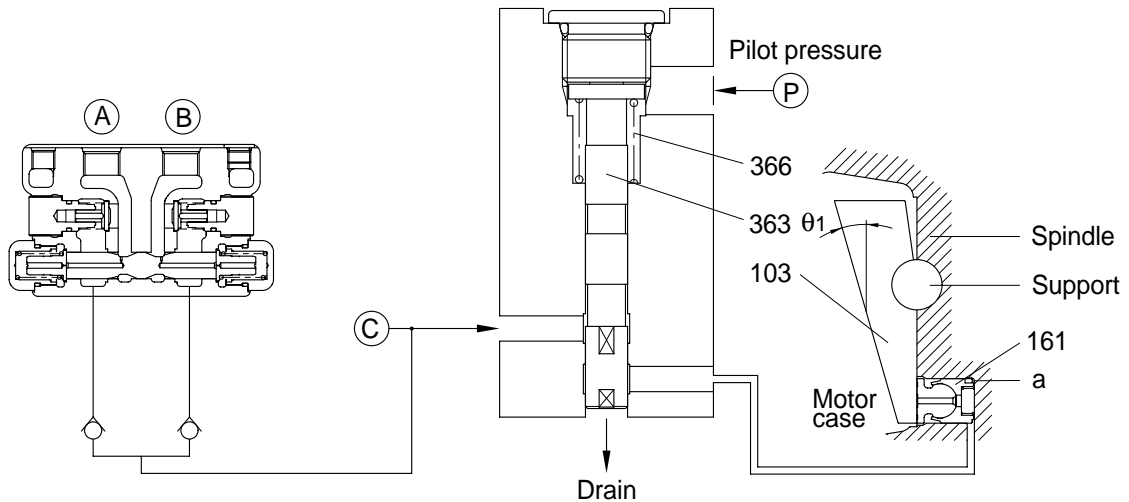

When the pilot pressure is shut off from port , valve(363) is pressed upward by the force of spring(366), the pressurized oil supply port is shut off, and oil in chamber is released into the motor case through the valve(363). Consequently, swash plate(103) is tilted at a maximum angle(θ_1) and the piston displacement of hydraulic motor becomes maximum, thus leading to low-speed operation.

At high speed - At pilot pressure of 20kgf/cm²(1.96Mpa) or more

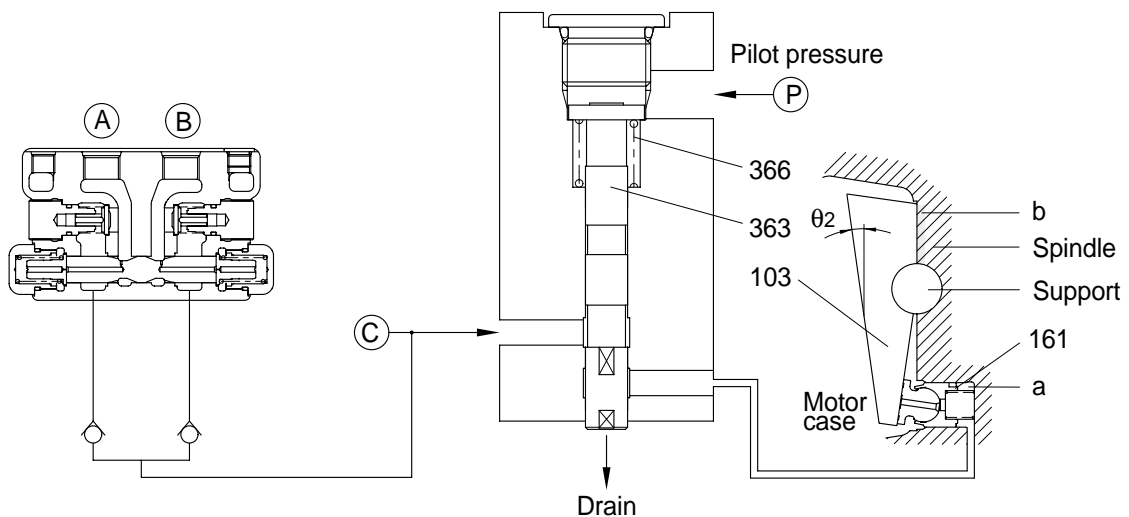

When a pilot pressure supplied from port (At a pressure of 20kgf/cm²(1.96Mpa) or more), the pressure overcomes the force of spring(366) and valve(363) is pressed downward. The pressurized oil supply port is then introduced into chamber through the valve(363). Piston (161) pushes up swash plate(103) until it touches side of the spindle. At this time, swash plate(103) is tilted at a minimum angle(θ_2) and the piston displacement of hydraulic motor becomes minimum, thus leading to high-speed operation.

2) REDUCTION GEAR

(1) Function

The reduction gear unit consists of a combination of simple planetary gear mechanism and differential gear mechanism. This mechanism reduce the high speed rotation from the hydraulic motor and convert it into low speed, high torque to rotate the hub(or case), which in turn rotates the sprocket.

(2) Operating principle

Upon rotation of the sun gear (S) via the input shaft, the planetary gear (P) engages with the fixed ring gear (R) while rotating on its axis.

Rotation around the fixed ring gear (R) is transmitted to the carrier (K).

$$i_1 = 1 + \frac{R \cdot P_2}{S \cdot P_1}$$

With rotation of the carrier (K), the planetary gears (P1) and (P2) rotate around the fixed ring gear (R).

When a proper difference in number of teeth is given between (P1) and (R) and between (P1) and (P2), a difference in rotation is produced on the gear (D) because the gears (P1) and (P2) are on the same axis.

$$i_2 = \frac{1}{1 - \frac{R \cdot P_2}{D \cdot P_1}}$$

Planetary gear mechanism

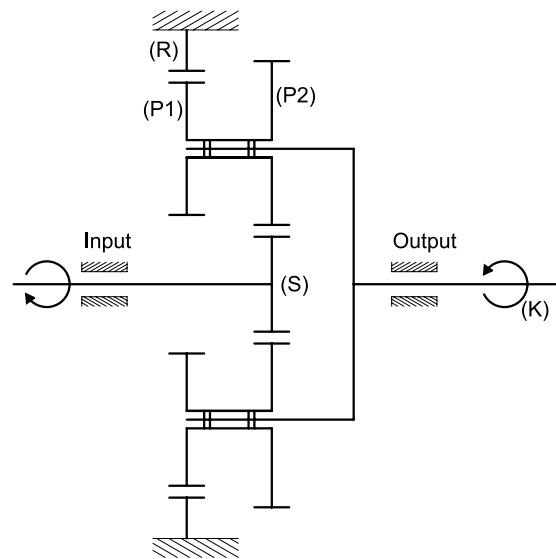

Differential gear mechanism

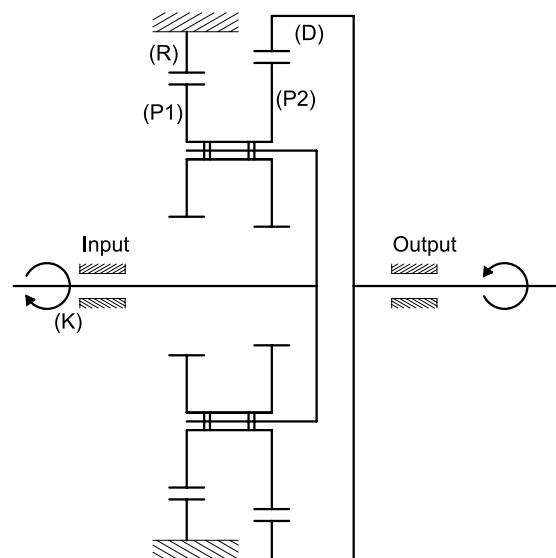

Upon rotation of the sun gear (S) via the input shaft, planetary motion is given among the gears (S), (P1) and (R) and rotation of the gear (P1) around another gear causes the carrier (K) to rotate.

This carrier rotation gives differential motion among the gears (R), (P1), (P2) and (D) to rotate the ring gear (D). The motor then rotates since the ring gear (D) is connected to the hub (case) of the motor.

$$i = i_1 \times i_2 = \frac{1 + \frac{R \cdot P_2}{S \cdot P_1}}{1 - \frac{R \cdot P_2}{D \cdot P_1}}$$

Combination of planetary gear mechanism and differential gear mechanism

