

GROUP 4 TRAVEL DEVICE

1. CONSTRUCTION

Travel device consists travel motor and gear box.

Travel motor includes brake valve, parking brake and high/low speed changeover mechanism.

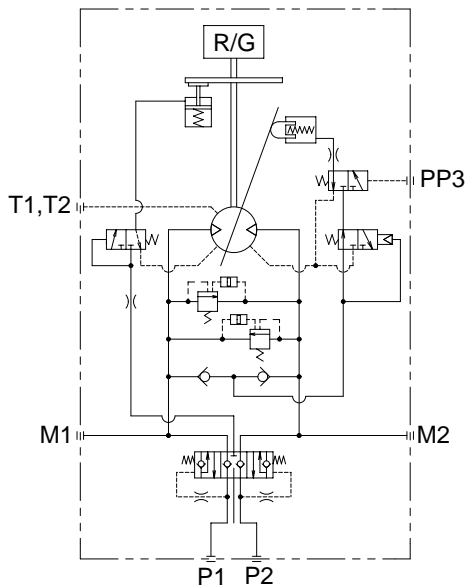
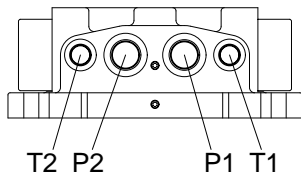
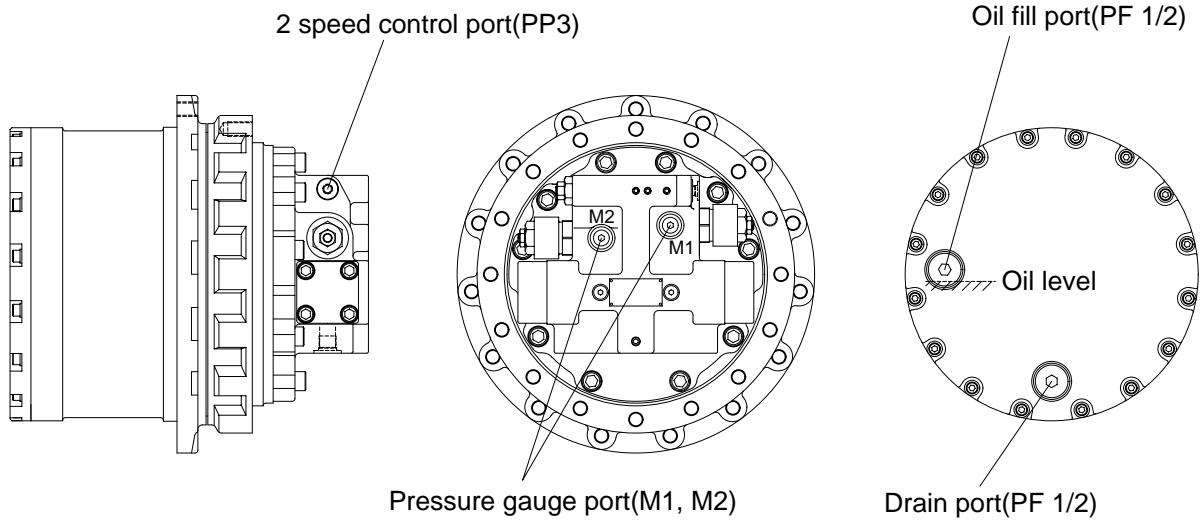

Port	Port name	Port size
P1	Main port	SAE 5000psi 1"
P2	Main port	SAE 5000psi 1"
M1, M2	Gauge port	PT 1/4
T1, T2	Drain port	PF 1/2
PP3	2 speed control port	PF 1/4

11072TM01

1) BASIC STRUCTURE

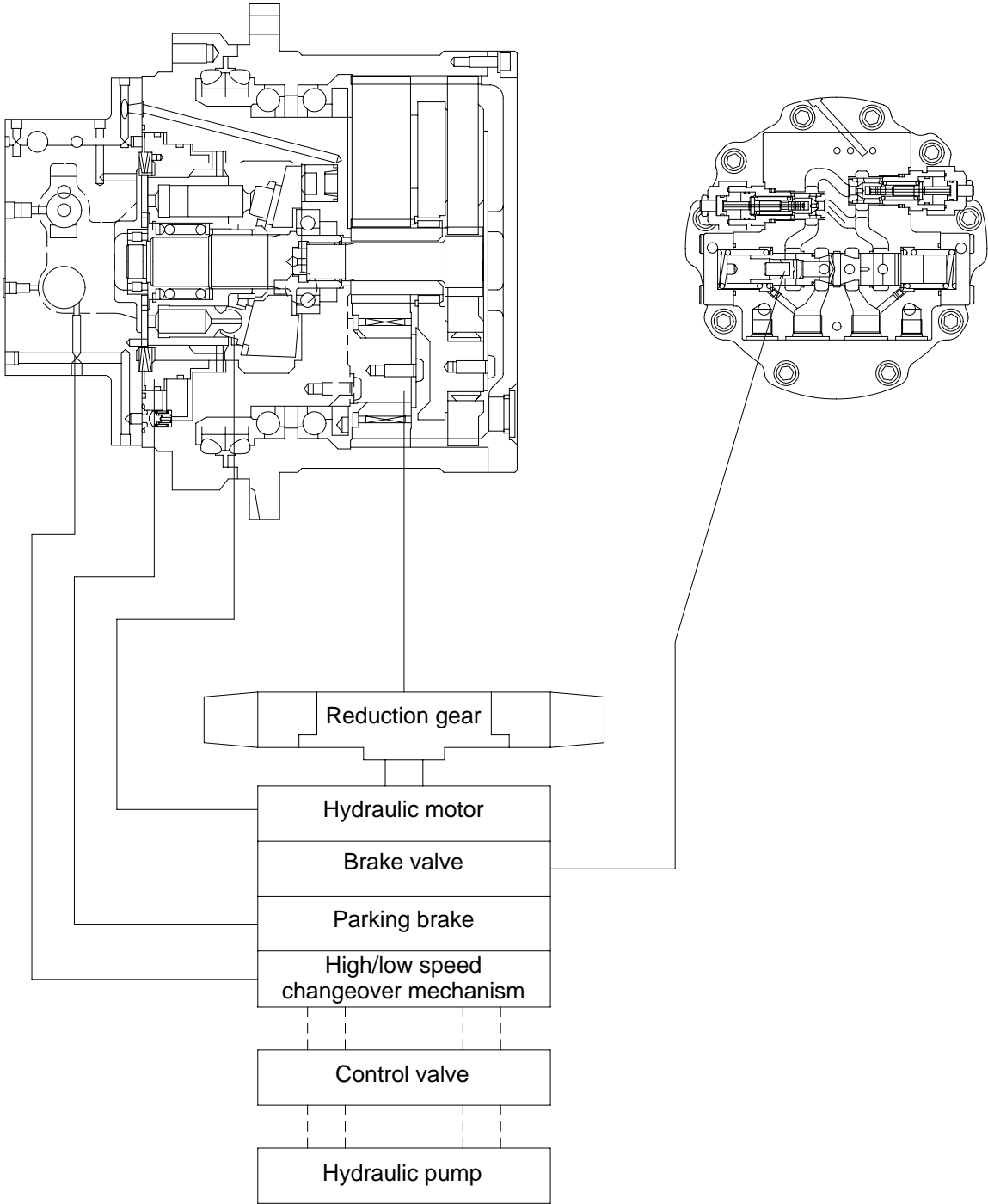

11072TM02

2) STRUCTURE

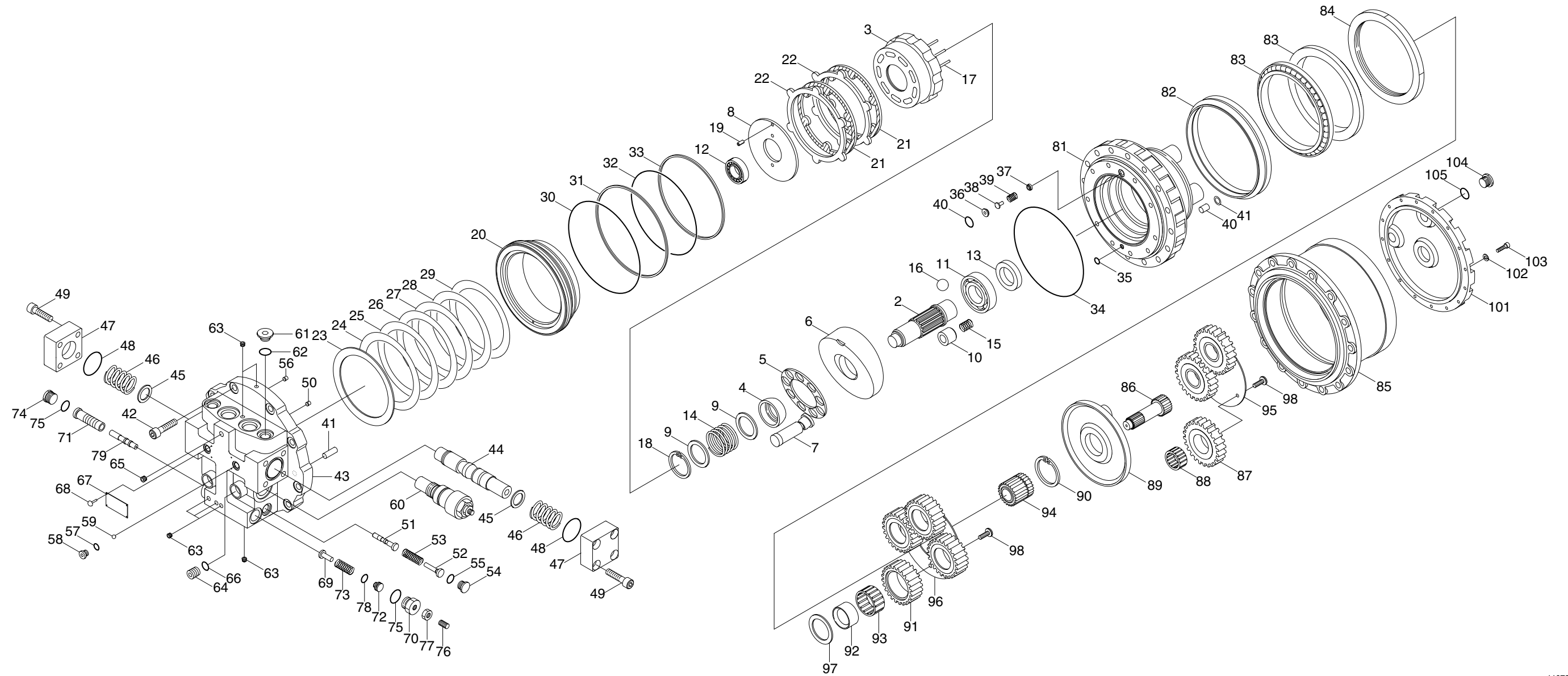

2	Shaft	20	Brake piston	37	Retainer	54	Plug	71	Sleeve	89	Carrier
3	Cylinder barrel	21	Friction plate	38	Poppet	55	O-ring	72	Stopper	90	Sun gear B
4	Ball retainer	22	Steel plate	39	Spring	56	Orifice	73	Spring	91	Planetary gear B
5	Retainer	23	Disk spring	40	O-ring	57	Steel ball	74	Plug	92	Bushing
6	Cam	24	Shim(1.0T)	41	Pin	58	Plug	75	O-ring	93	Needle bearing B
7	Piston assembly	25	Shim(1.2T)	42	Bolt	59	O-ring	76	Screw	94	Snap ring
8	Valve plate	26	Shim(1.4T)	43	Motor cover assembly	60	Relief valve assembly	77	Nut	95	Thrust plate(2)
9	Plate	27	Shim(1.6T)	44	Spool assembly	61	Plug	78	O-ring	96	Thrust plate(3)
10	Piston assembly	28	Shim(1.8T)	45	Washer	62	O-ring	79	Rod	97	Thrust plate(4)
11	Ball bearing	29	Shim(2.0T)	46	Spring	63	Plug	81	Casing body	98	Screw
12	Roller bearing	30	O-ring	47	Cover	64	Plug	82	Floating seal	99	Washer
13	Oil seal	31	Back up ring	48	O-ring	65	Plug	83	Angular bearing	100	Parallel pin
14	Spring	32	O-ring	49	Bolt	66	O-ring	84	Ring nut	101	Cover
15	Spring	33	Back up ring	50	Orifice	67	Name plate	85	Casing gear	102	Spring washer
16	Steel ball	34	O-ring	51	Spool	68	Rivet	86	Sun gear A	103	Bolt
17	Pin	35	O-ring	52	Stopper	69	Spring guide	87	Planetary gear A	104	Plug
18	Snap ring	36	Seat	53	Spring	70	Plug	88	Needle bearing A	105	O-ring

11072TM04

2. FUNCTION

1) HYDRAULIC MOTOR

(1) Motoring function

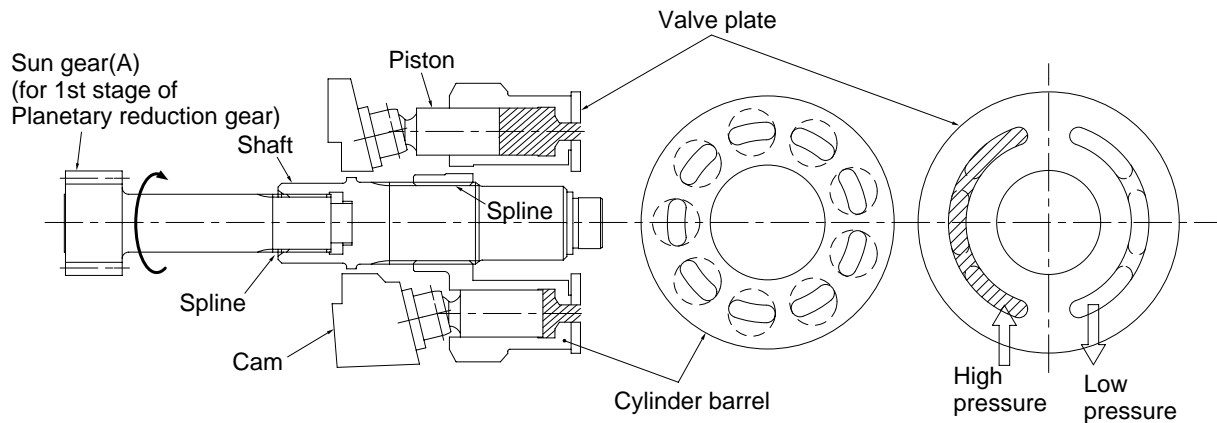

11072TM05

High-pressure oil is supplied to the left port of motor.

The oil goes into the cylinder barrel through the valve plate. The high pressure pushes the piston to the left. The piston moves to the left position and simultaneously rotates the cylinder barrel sliding on the cam surface. Shaft is connected to the cylinder barrel and the planetary gear (A) is connected to the shaft. So, the rotation is taken out by the sun gear rotation as shown.

When high-pressure oil is supplied to the opposite port of the motor, then the rotating direction is reversed and the sun gear (A) rotates in the reversed direction.

The rotation of sun gear (A) is transferred to the reduction gear section.

The torque and speed generated by the motor depends on the displacement (=volume per revolution) of the motor.

The volume per revolution depends on the cam angle θ .

(2) Speed-shifting function

The torque and speed generated by the motor depends on the displacement of the motor. And the displacement depends on the cam angle θ .

The bigger the cam angle θ is, the higher the torque is and the lower the speed is.

The smaller the cam angle θ is, the lower the torque is and the higher the speed is.

This travel drive is equipped with a speed shifting piston, and when high pressure oil is supplied to it, the speed-shifting piston pushes cam and makes the cam angle smaller. This means that the mode is shifted from low speed mode to high speed mode.

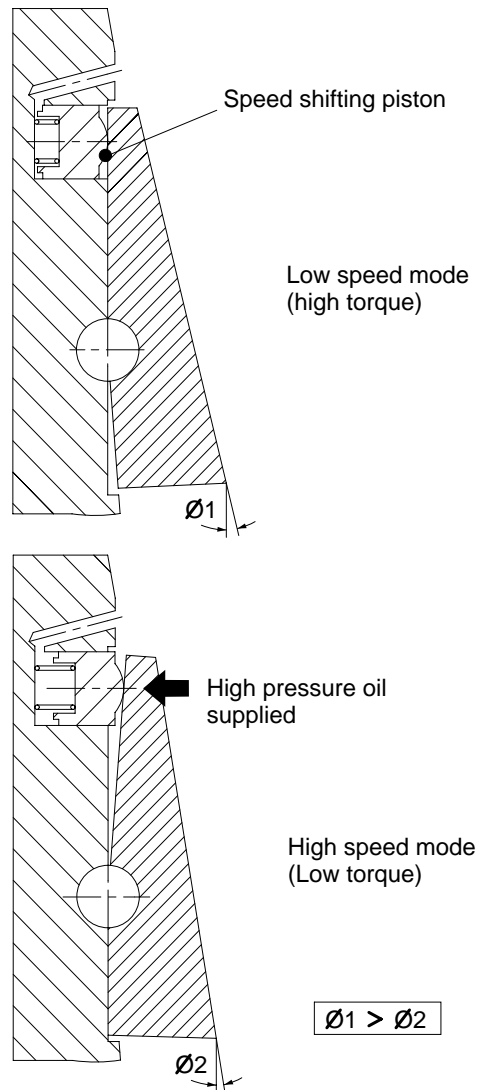

11072TM06

(3) Parking brake function

This travel drive is equipped with a parking brake. It gives parking brake torque to the motor when high pressure oil is NOT supplied to the motor and the motor is NOT traveling. Also, it releases parking brake when high-pressure oil is supplied to the motor and the motor is traveling.

As high-pressure oil is supplied to the travel motor, the parking brake is quickly released and the motor starts rotation.

When the high pressure oil supply to the motor stops, the motor stops rotation and the parking brake is slowly activated by the brake piston motion because of the force of a pair of disk springs.

Slow activating and quick releasing of parking brake can prevent possible damage to friction plates and steel plates.

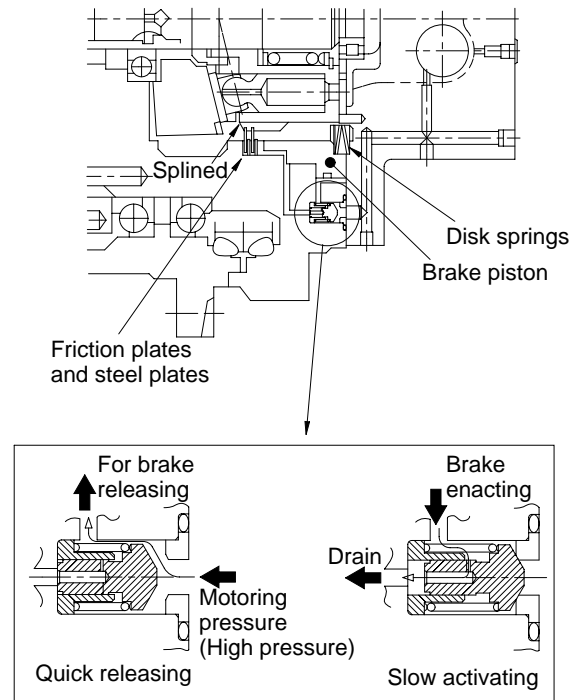

11072TM07

2) BRAKE VALVE

(1) Counterbalance valve function

Level travel

When high pressure oil is NOT supplied to the brake valve, CBV spool is at the center because of two springs beside it. Now oil flow passage from motor is closed.

When high-pressure oil is supplied to the right port of brake valve, CBV spool is moved to the left position because of the pressure at the right end of CBV spool. Now that oil-flow passage from the motor is open at the left shoulder of the CBV spool, oil flows and motor rotates.

When supplied pressure at the right port is decreased during the vehicle deceleration or stopping process, there is a pressure decrease at the right end of CBV spool.

Then CBV spool is moved to the right direction because of the spring force at the left side of CBV spool. Then oil-flow passage from the motor at the shoulder of the CBV spool gets narrower and at last it is closed when high pressure oil supply is shut-up to brake valve.

In this passage closing process, there occurs a pressure increase in outlet side of the motor ("=back pressure").

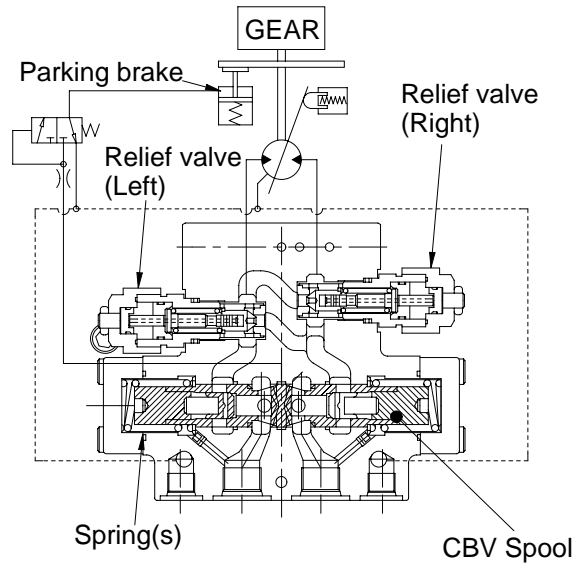

11072TM08

Down-slope travel

- If there is NOT a counterbalance valve equipped

When the vehicle travels down a slope, gravity makes the travel drives rotate more speedily than you intended. The "overrunning" cannot be controlled by the supplying oil flow rate. Also, the pumps cannot maintain the oil supply to the motors and there will be a negative pressure in the inlet side of motor. This might cause cavitation in the travel motors.

- Function and mechanism of counterbalance valve

In down-slope traveling, the pressure at the right port decreases because of lack of supplied oil. Then, the pressure at the right end of CBV spool also decreases and CBV spool moves back to the right direction from the left position. Now that oil-flow passage from the motor at the shoulder of the CBV spool gets narrower and then there will occur a pressure increase in outlet side of the motor (= "back pressure").

This "back pressure" can prevent the motor from "overrunning" and cavitation.

Oil supply for parking brake release

For starting the travel drive rotation, when pump oil is supplied to the right port of brake valve, CBV spool moves to the left position and also opens passage to parking brake releasing.

When the travel drive is in "stop" state, passage to brake releasing is closed.

As to the detail of parking brake function, please refer to "(3) parking brake function".

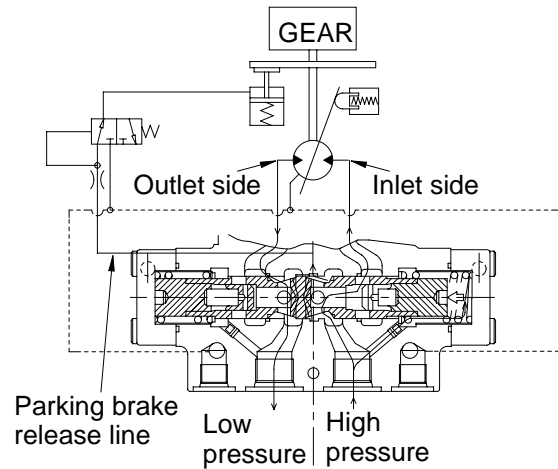

11072TM09

(2) Crossover relief valve function

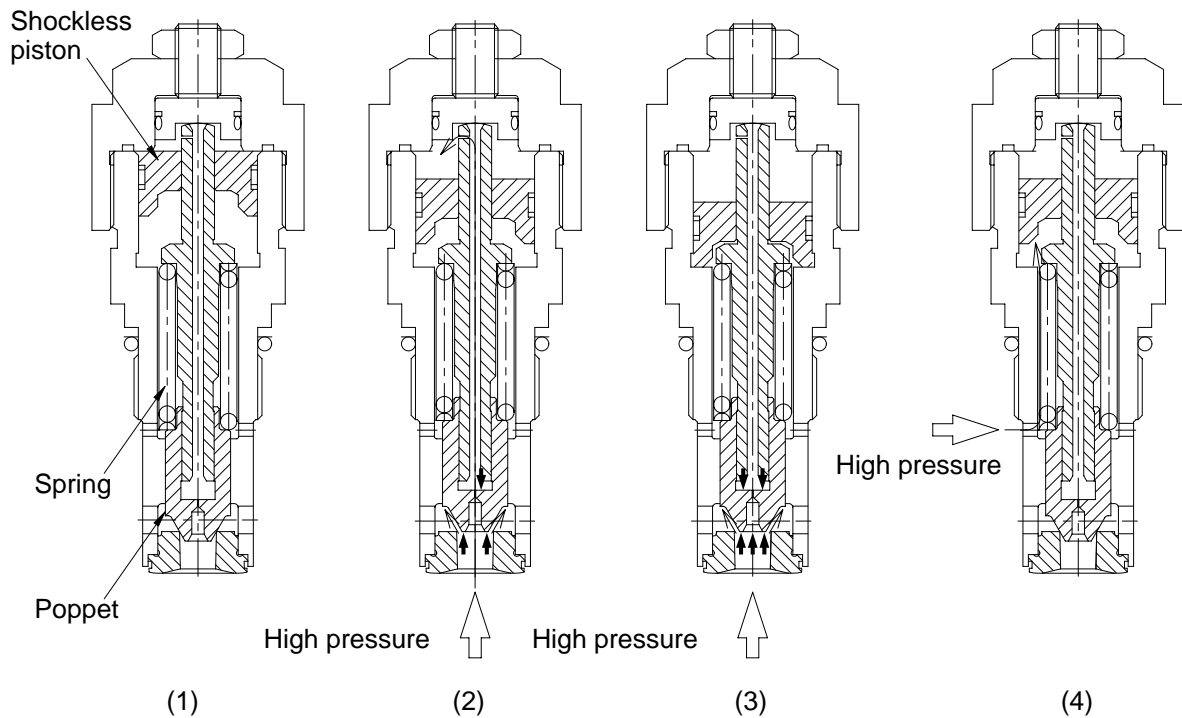

11072TM10

This travel drive is equipped with a pair of shockless crossover relief valves. The purpose is as below :

- The relief valve prevents the occurrence of a shock load while travel deceleration or stopping process.
- It prevents overload to the motor.
- It compensates for the lack of oil during vehicle deceleration or stopping processes.
- The relief valves are "shockless" type, which is effective for shock reduction.

If there is NOT a crossover relief valves equipped(considering two cases for example)

- When the vehicle is in slowing down or stopping operation stage, a pressure increase (= "back pressure") occurs in the motor because of the function of counterbalance valve as mentioned in "2)-(1) counterbalance valve function". If the stopping operation for vehicle is sudden, this "back pressure" occurs suddenly and it may cause a shocking feeling for the operator, or in worse cases, break down of the machine.
- When the vehicle is in the rotation starting operation stage, high pressure will be applied into the motor. If the starting operation is too sudden, a sudden pressure increase occurs in the motor. It may cause a shock.

In order to make the harmful pressure shock softer, and for operator feeling improvement or for machine protection, this travel drive is equipped with crossover relief valve.

Function and mechanism of shock-less crossover relief valves

Please refer to the figures in "2)-(1) counterbalance valve function" and on this page.

The explanation below is described about relief valve(right).

Firstly, the relief valve(right) is in condition (1) previous page.

When a sudden pressure increase occurs in the outlet side of the motor in deceleration or stopping process, the shock of high pressure pushes down shockless piston in the relief valve as shown in (2), while relieving high pressure oil with poppet moving up.

During moving down shockless piston, the pressure behind the poppet is not so high because of the existence of flow moving down the shockless piston, and relieving pressure is rather low.

Next, when the shockless piston has been completely pushed down to the end of stroke as shown in (3), the relieving pressure increases to the finally intended set pressure, because there is no more flow moving down the shockless piston, and the pressure behind the poppet is high.

After stopping the motor, when you start rotating the motor again, resetting of shockless piston occurs, pushing up the shockless piston up with the high pressure in the inlet side of the motor.

Oil compensation

During the relieving action, the relief valve also have a function of oil flow compensation giving the relieved oil flow from the outlet side to the inlet side. This function helps to prevent a vacuum condition in the motor.

(3) Automatic 2-speed shifting function

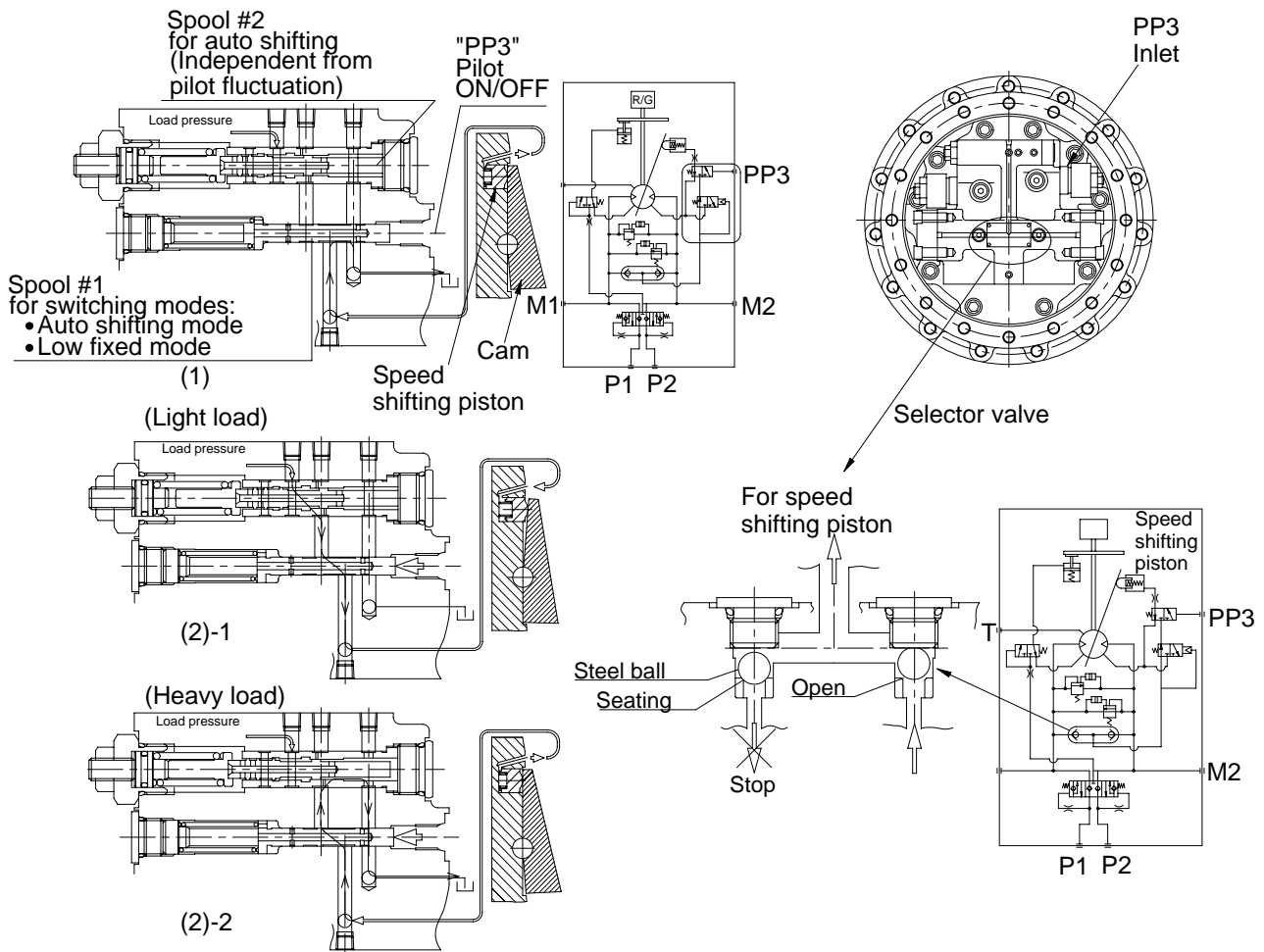

11072TM11

Automatic 2-speed shifting function has two modes (1) and (2) as below :

- (1) Low speed fixed mode... always low speed
- (2) Automatic 2-speed shifting mode
 - (2)-1 When motor load pressure is light, High speed.
 - (2)-2 When motor load pressure is heavy, Low speed.

This function above consists of three components.

- Spool #1 for switching modes
 - Auto-shifting mode(if PP3 is applied)
 - Low-speed-fixed mode (if PP3 is NOT applied)
- Spool #2 for auto shifting
 - If load pressure < set value then High-speed
 - If load pressure > set value then Low-speed
- Selector valve, which always picks out high pressure and provide it to the SPOOL #2 regardless of the rotating direction of motor.

Functions

Please refer to (1) shown above.

When the pilot pressure PP3 is NOT applied, SPOOL #1 is at the right position because of the spring behind the spool. Now the motor is always at low speed regardless of the position of SPOOL #2.

When the pilot pressure PP3 is applied, SPOOL #1 is at the left position because of PP3. Now the motor is at automatic 2-speed-shifting mode. The displacement of the motor can be changed based on the motor load pressure.

Please refer to (2)-1.

Now the pilot pressure is applied, and the motor is at automatic 2-speed-shifting mode. When the motor load pressure is low, SPOOL #2 is at the right position because of the spring behind the spool. And the load pressure is led to the chamber behind the speed-shifting piston and it pushes piston and changes the cam angle smaller. This means that the motor is at High speed.

Please refer to (2)-2.

Now the pilot pressure is applied, and the motor is at automatic 2-speed-shifting mode. When the motor load pressure is high, SPOOL #2 is at the left position because of the motor load pressure pushing the spool to the left. Then the load pressure is locked at the SPOOL #2 and is NOT led to the chamber behind the speed-shifting piston. The cam angle remains big. This means that the motor is at Low speed.

As to the detail of cam angle change, please refer to "1) Hydraulic motor section (2) speed-shifting function".

3) REDUCTION GEAR

(1) Function

A general construction of planetary reduction gear system is as shown right. The system mainly consists of these parts below.

NAME	Number of teeth
Sun Gear	Z_s
Planetary gears	Z_p
Carrier	-
Ring gear	Z_r

Planetary type

Firstly, let's think about the case that Ring Gear is fixed and rotation is given to Sun gear. This is called "PLANETARY TYPE" as sun gear rotates clockwise, planetary gears will revolve around sun gear, and the revolution will rotate carrier.

Now we can take the clockwise rotation at carrier by giving a clockwise rotation to sun gear.

The rotation speed of carrier(output) is different from that of sun gear(input) as below.

(input)/(output) is called "Reduction ratio(i)".

$$\text{Reduction ratio (i)} = (\text{Input})/(\text{Output}) = Z_r / Z_s + 1$$

Star type

Next let's think about the case that the carrier is fixed and rotation is given to sun gear. This is called "STAR TYPE" as sun gear rotates clockwise, planetary gears will rotate at the same position, and they will make ring gear rotate counter-clockwise.

Now we can take out a counterclockwise rotation at ring gear by giving a clockwise rotation to sun gear.

The rotation speed of ring gear is different from that of sun gear as below.

$$\text{Reduction ratio (i)} = (\text{Input})/(\text{Output}) = Z_r / Z_s$$

Planetary reduction gear system

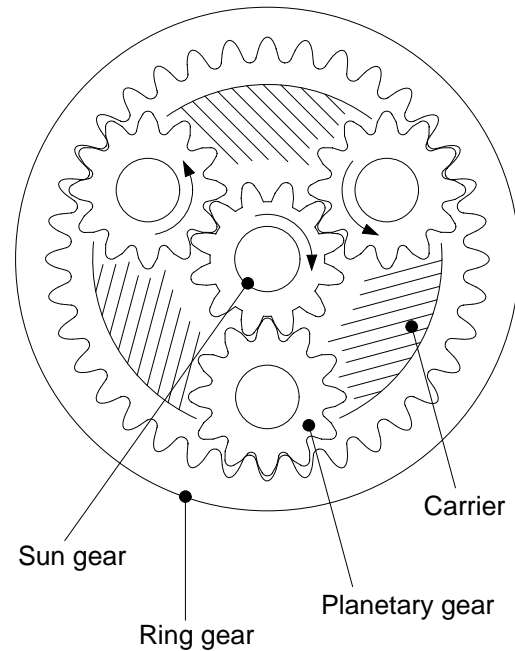

11072TM12

In the travel drive

This travel drive is equipped with 2-stage planetary reduction gear system, which consists of mixture of PLANETARY TYPE and STAR TYPE.

Input is given to sun gear of 1ST stage and output is taken out at ring gear.

Ring gear is commonly used in 1ST stage and 2ND stage.

The reduction ratio is as below

$$\begin{aligned} \text{Reduction ratio (i)} &= (\text{Input})/(\text{Output}) \\ &= (Z_r / Z_{s1} + 1) \times (Z_r / Z_{s2} + 1) - 1 \end{aligned}$$

Here

Z_{s1} = Number of teeth for 1ST stage sun gear

Z_{s2} = Number of teeth for 2ND stage sun gear

Z_r = Number of teeth for ring gear