

SECTION 5 STEERING SYSTEM

Group 1 Structure and Function	5-1
Group 2 Operational Checks and Troubleshooting	5-19
Group 3 Tests and Adjustments	5-28
Group 4 Disassembly and Assembly	5-36

SECTION 5 STEERING SYSTEM

GROUP 1 STRUCTURE AND FUNCTION

1. OUTLINE

The steering system of this machine is a dynamic load sensing steering system.

This system offers faster response from the priority valve of flow amplifier and the pump. Also it offers advantages in connection with cold start up and improvements in system stability.

The components of the steering system are :

- Steering pump
- Flow amplifier
- Steering unit
- Steering cylinders

The flow amplifier contains a directional valve, an amplification stage, a priority valve, a pilot pressure relief valve and shock and suction valve.

The steering pump, the first pump of hydraulic pump, draws hydraulic oil from the reservoir.

Outlet flow from the pump flows to the priority valve of flow amplifier. The priority valve of flow amplifier preferentially supplies flow, on demand, to the steering unit. When the machine is steered, the steering unit routes flow to the steering cylinders to articulate the machine.

When the machine is not being steered, or if pump flow is greater than steering flow, the priority valve supplies flow to the loader system.

That is, output flow from the steering pump enters into the main pump for the operation of the attachment.

1) NEUTRAL

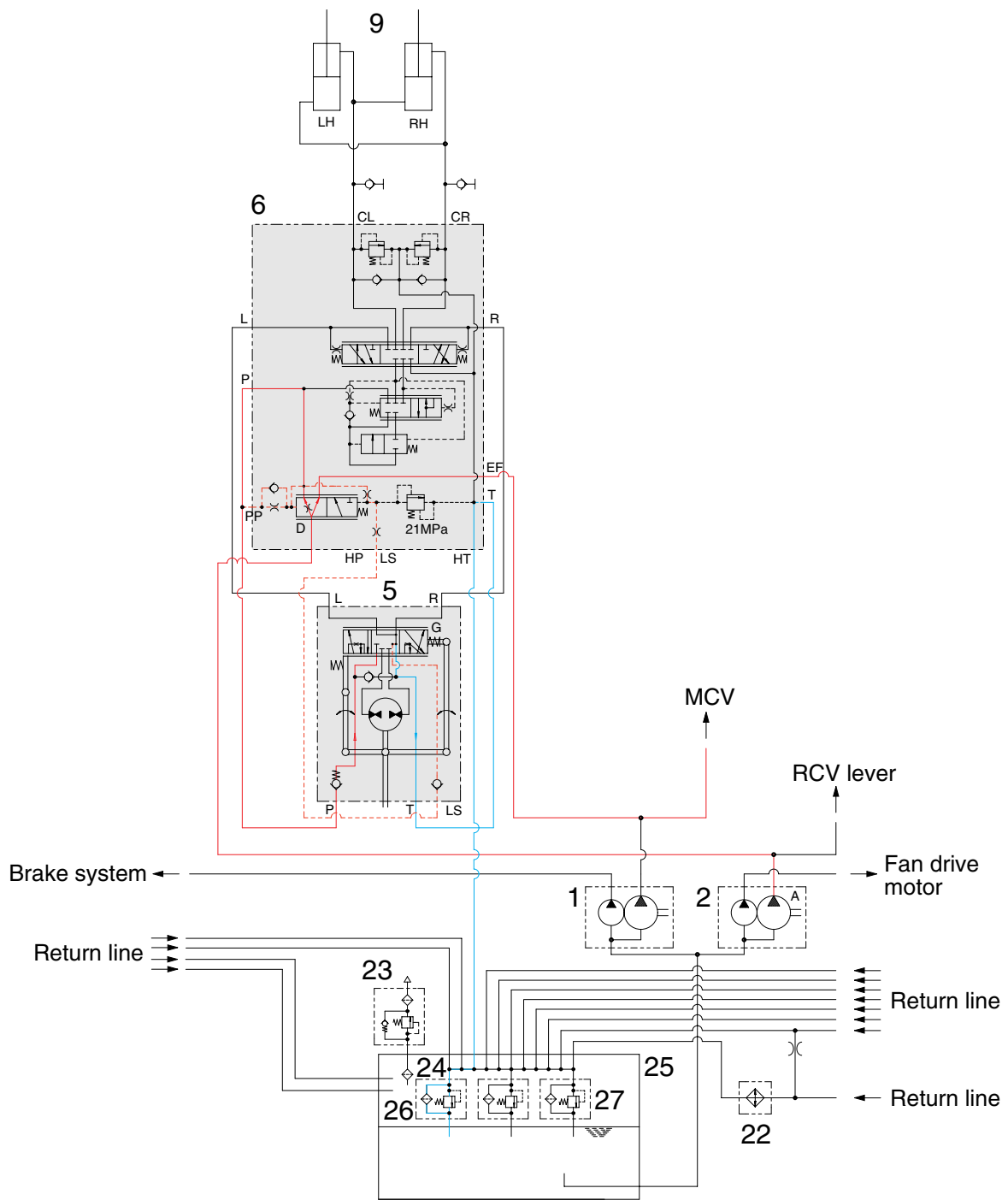

7807ASE02

- The steering wheel is not being operated so control spool(G) does not move.
- The oil from the steering pump(A) enters port HP of the priority valve of flow amplifier and the inlet pressure oil moves the spool(D) to the right.
- Almost all of pump flow goes to the loader system(Main control valve) through the EF port and partly flows into the hydraulic tank(25) through the control spool(D).
- This small flow is useful to prevent the thermal shock problem of the steering unit(5).

2) LEFT TURN

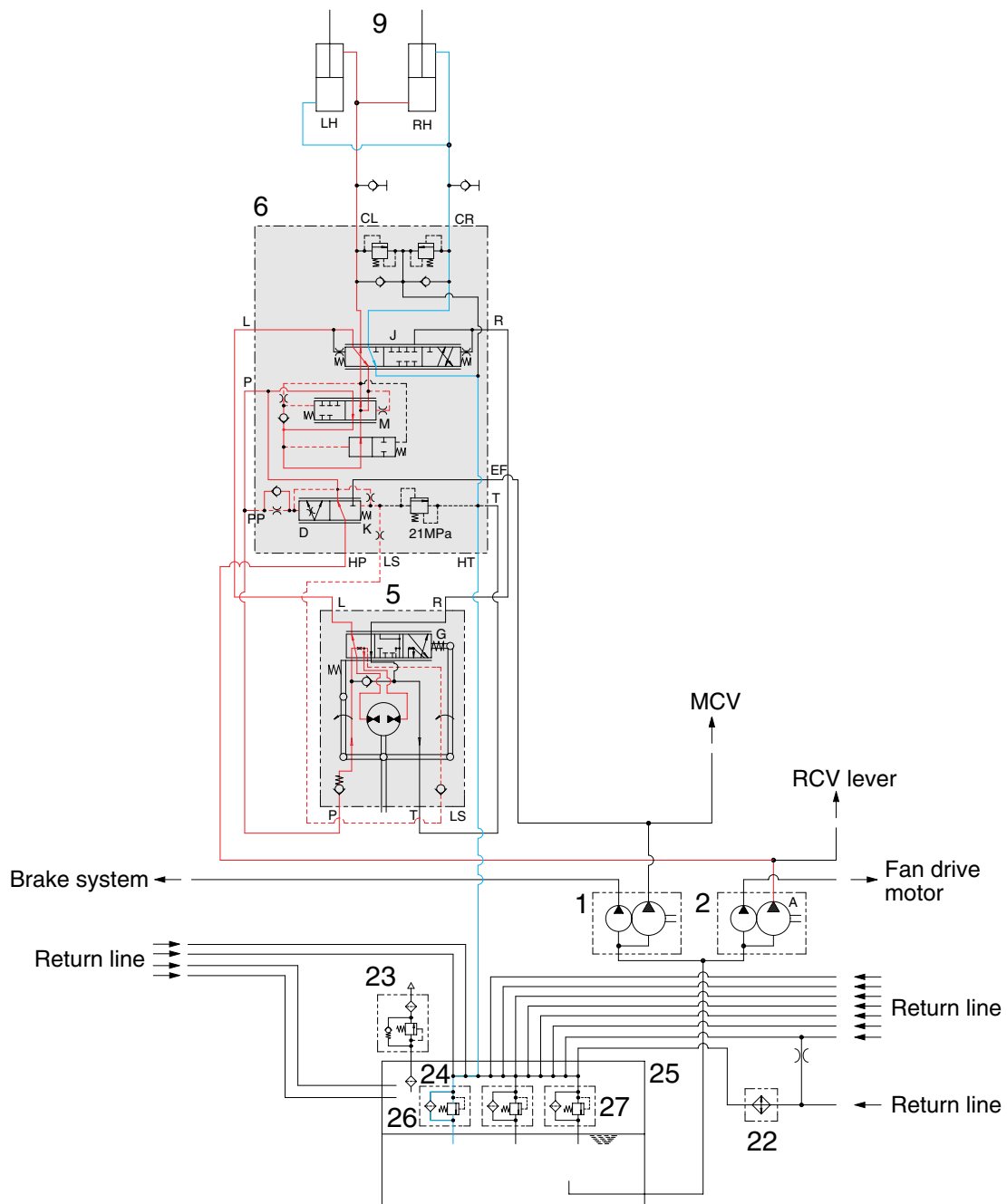

7807ASE03

- When the steering wheel is turned to the left, the spool(G) within steering unit(5) connected with steering column shaft is pushed to the right direction.
- The oil discharged from the pump(A) flows into HP port of flow amplifier(6).
- The delivered oil passes through the main orifice of steering unit(5), through the priority valve spool (D) of flow amplifier(6). The position of priority spool(D) is determined when the pressure difference between front and rear of main orifice is balanced with control spring(K) force.
- The oil supplied through the directional spool(J) from the steering unit(5) is combined with the direct oil from the priority valve spool(D) in the amplifier spool(M). The amplified oil flows into the small chamber of the left steering cylinder and large chamber of the right steering cylinder respectively.
- Oil returned from left and right cylinder returns to hydraulic tank through directional spool(J) of flow amplifier(6).
- When the above operation is completed, the machine turns to the left.

3) RIGHT TURN

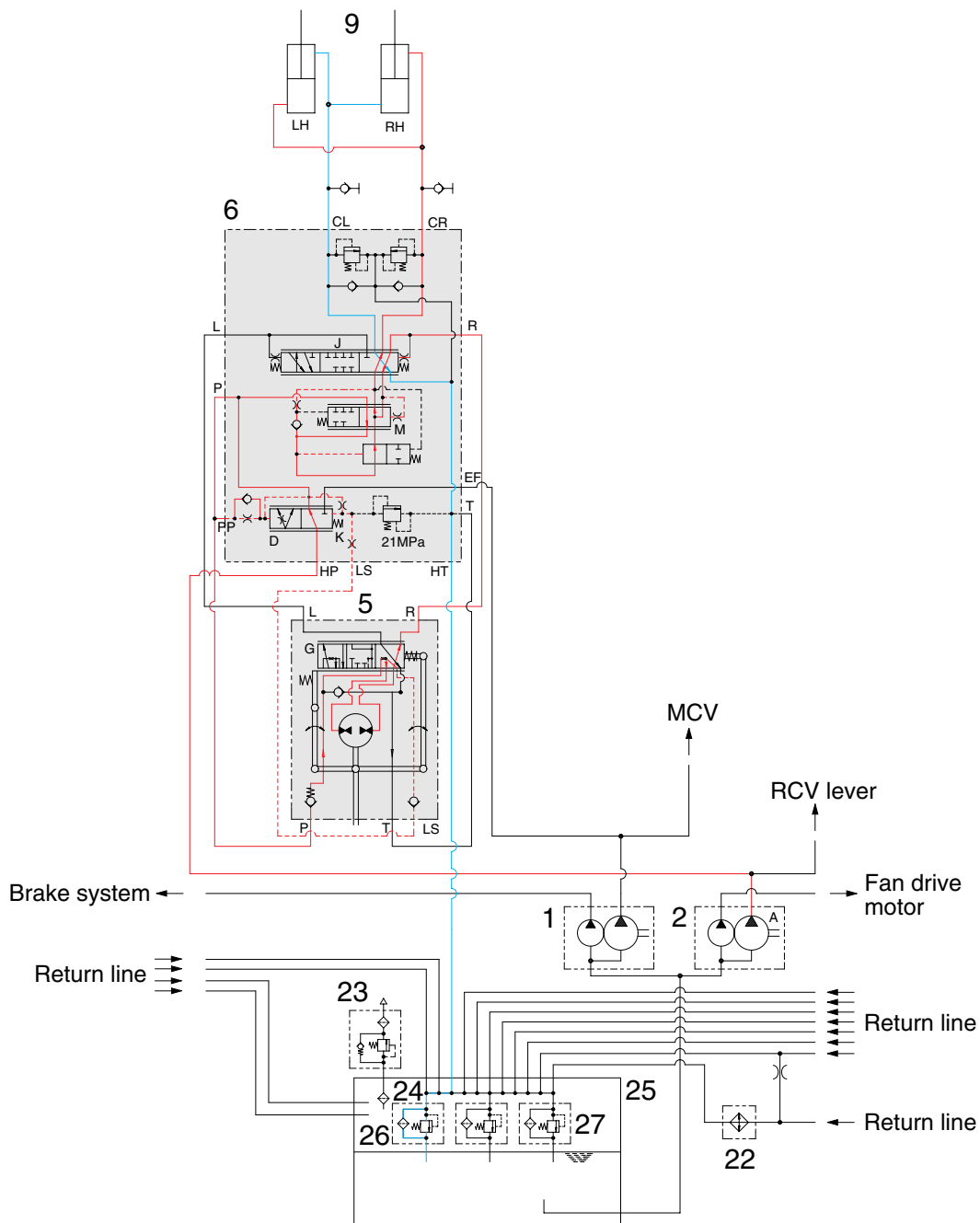

7807SE04

- When the steering wheel is turned to the right, the spool(G) within steering unit(5) connected with steering column shaft is pushed to the right direction.
- The oil discharged from the pump(A) flows into HP port of flow amplifier(6).
- The delivered oil passes through the main orifice of steering unit(5), through the priority valve spool (D) of flow amplifier(6). The position of priority spool(D) is determined when the pressure difference between front and rear of main orifice is balanced with control spring(K) force.
- The oil supplied through the directional spool(J) from the steering unit(5) is combined with the direct oil from the priority valve spool(D) in the amplifier spool(M). The amplified oil flows into the small chamber of the right steering cylinder and large chamber of the left steering cylinder respectively.
- Oil returned from left and right cylinder returns to hydraulic tank through directional spool(J) of flow amplifier(6).
- When the above operation is completed, the machine turns to the right.

3. STEERING PUMP(+FAN PUMP)

1) STRUCTURE

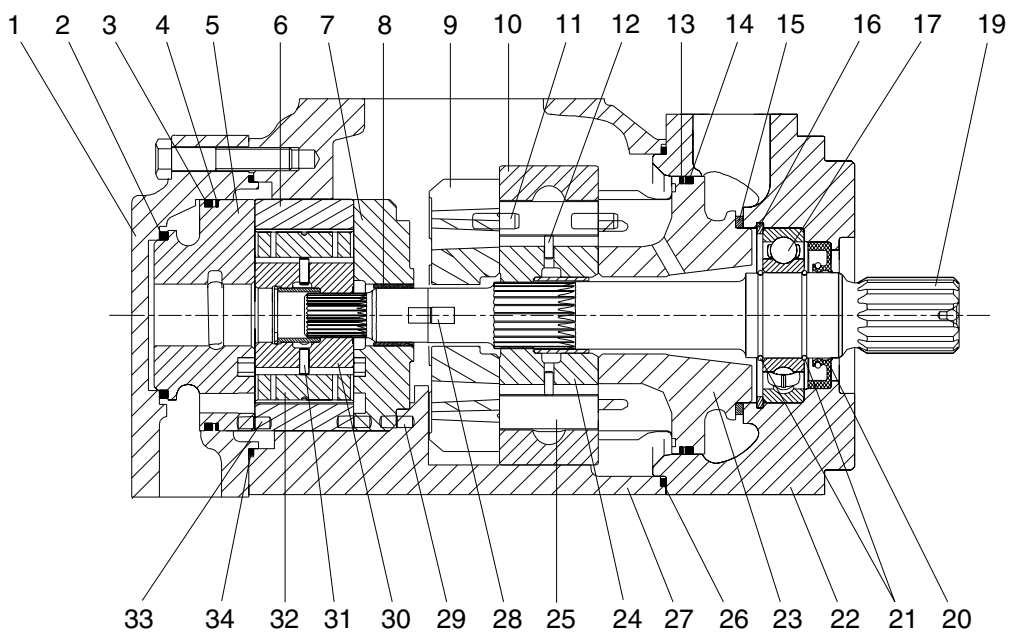
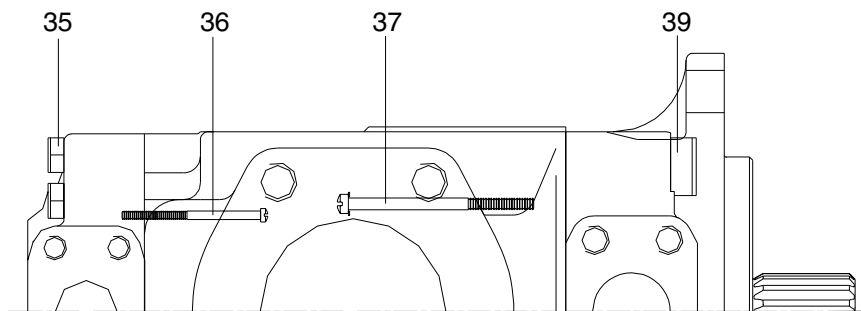

7807AWE09

- | | | | | | |
|----|---------------------|----|---------------------|----|------------------|
| 1 | End cap | 14 | Section seal | 28 | Dowel pin |
| 2 | Section seal | 15 | Section seal | 29 | Dowel pin |
| 3 | Section seal | 16 | Retaining ring | 30 | Rotor assembly |
| 4 | Back up ring | 17 | Ball bearing | 31 | Vane holdout pin |
| 5 | Pressure port plate | 19 | Shaft | 32 | Vane |
| 6 | Camring | 20 | Shaft seal | 33 | Dowel pin |
| 7 | Rear port plate | 21 | Round section ring | 34 | Section seal |
| 8 | Bushing | 22 | Mounting cap | | |
| 9 | Rear port plate | 23 | Pressure port plate | 35 | Screw |
| 10 | Camring | 24 | Rotor assembly | 36 | Screw |
| 11 | Dowel pin | 25 | Vane | 37 | Screw |
| 12 | Vane holdout pin | 26 | Section seal | 39 | Screw |
| 13 | Back up ring | 27 | Housing | | |

2) DESCRIPTION

The main vane pump consist of six basic components : end cap(2), **P2** section unitized cartridge(4) consisting of ; rotor, vanes, vane holdout pins, cam ring, port plate, and pressure plate, center housing(5), **P1** section unitized cartridge(6) consisting of ; rotor, vanes, vane holdout pins, cam ring, port plate, pressure plate, shaft(11) and bearing and mounting cap(14).

The main vane pump features the use of unitized pumping cartridge for both the **P1** and **P2** pump section.

The unitized cartridge assemblies are pretested and provide for ease of disassembly and assembly in the event it becomes necessary or desirable to make repairs, overhaul or revise the flow delivery.

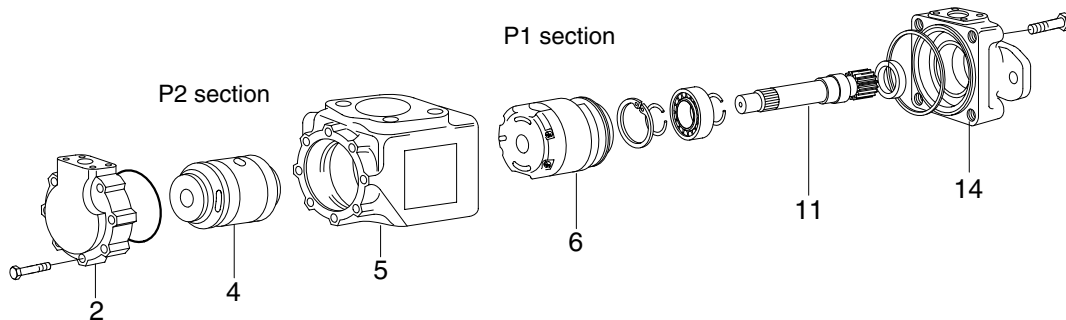

7707WE10

3) OPERATION

The pumping operation of this unit(each cartridge) is obtained by providing a fixed interior cam surface and a rotating inner member(rotor) containing vanes which held in contact with the inner cam surface. As the rotor is rotated by the drive shaft, the vanes are urged outward against the outward sloping cam surface, forming a cavity at the inlet ports of the port plates. Atmospheric pressure and suction created by the expanding cavity between the rotating vanes fill the inlet cavity with fluid.

As the rotation continues and the vanes that had previously moved outward and now have fluid trapped between them and the port plates, follow the inward slope of the cam which decreases the cavity containing the trapped fluid and discharges the fluid at system pressure through the pressure port openings in the port plates.

The rotating portion of the unitized cartridges feature the use of pressure actuated vanes which are urged against the cam ring by pins located in the bottom of each rotor vane slot. Initial force to bring the vanes in contact with the cam ring contour during start up is provided by centrifugal force.

When pumping operation starts and pressure is established, fluid under pressure fills the pin cavity through the feed holes.

The feed holes open to the pressure port twice every revolution. All other times they are closed off by the port plate. This pressure under the pin provides the force necessary to keep the vanes in contact with the cam contour.

- ※ When operating the pump at the maximum outlet pressure, the pump shaft rotation should not be allowed to fall below 600rpm in order to maintain proper vane to cam ring contact. The inlet or suction flow for both the **P1** cartridge and **P2** cartridge feeds through a common 3 port in the center housing, through the large ports of each port plate for each cartridge and through the center hole in the suction zone of each cam ring.

4. FLOW AMPLIFIER

1) STRUCTURE

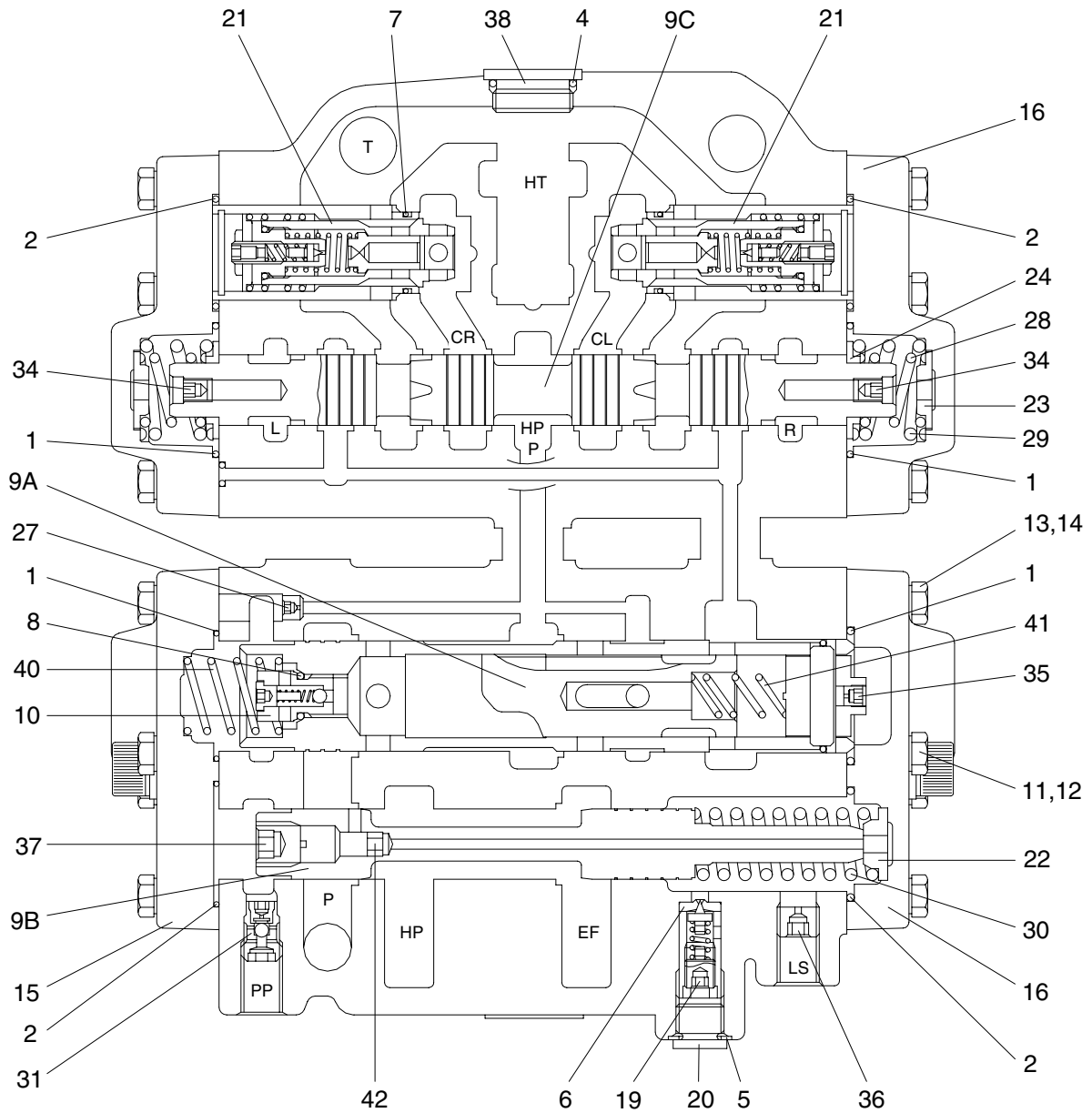

1	O-ring	12	Spring washer	28	Spring
2	O-ring	13	Screw	29	Spring
4	O-ring	14	Spring washer	30	Spring
5	Washer	15	End cover	31	Throttle check valve
6	Washer	16	End cover	34	Orifice
7	O-ring	19	Relief valve	35	Orifice
8	O-ring	20	Plug	36	Orifice
9A	Amplifier valve	21	Shock, suction valve	37	Plug
9B	Priority valve	22	Spring seat	38	Plug
9C	Directional valve	23	Spring seat	40	Spring
10	Check valve	24	Spring guide	41	Spring
11	Screw	27	Orifice	42	Orifice

2) OPERATION

(1) Introduction

The flow amplifier contain a directional valve, an amplification stage, a priority valve, a pilot pressure relief valve and shock and suction valves.

The flow amplifier amplifies the oil flow from the steering unit cylinder ports L or R by an amplification factor of 8. The amplified oil flow is directed from the flow amplifier ports CL or CR to the steering cylinder. The amplified flow is proportional to the rate of the steering wheel rotation. If the oil flow from the pump fails, the flow amplifier cuts off the amplification.

(2) Priority valve

The priority valve is used in load sensing systems where the same pump supplies oil to both steering system and working hydraulics.

The steering system always has first priority.

The pressure on the LS connection is almost zero during measuring(Steering unit in neutral position).

(3) Shock valves

The shock valves protect the flow amplifier against shock from external forces on the steering cylinders. The shock valves in flow amplifier limit the maximum pressure drop from CL to HT and from CR to HT.

(4) Suction valves

The suction valves ensure oil suction on the side of the steering cylinder pistons where in unfavorable conditions cavitation might occur.

(5) HP-HT ports characteristic

The pilot pressure relief valve protects the steering unit against excess pressure. The pilot pressure relief valve together with the priority valve limit the maximum steering pressure HP-HT.

(5) Neutral

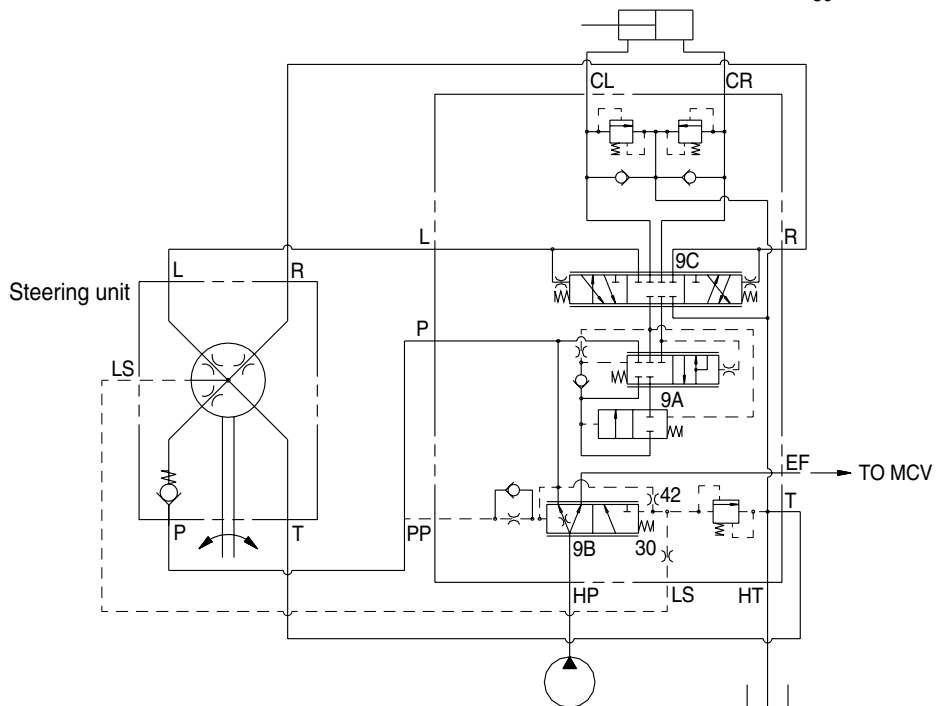
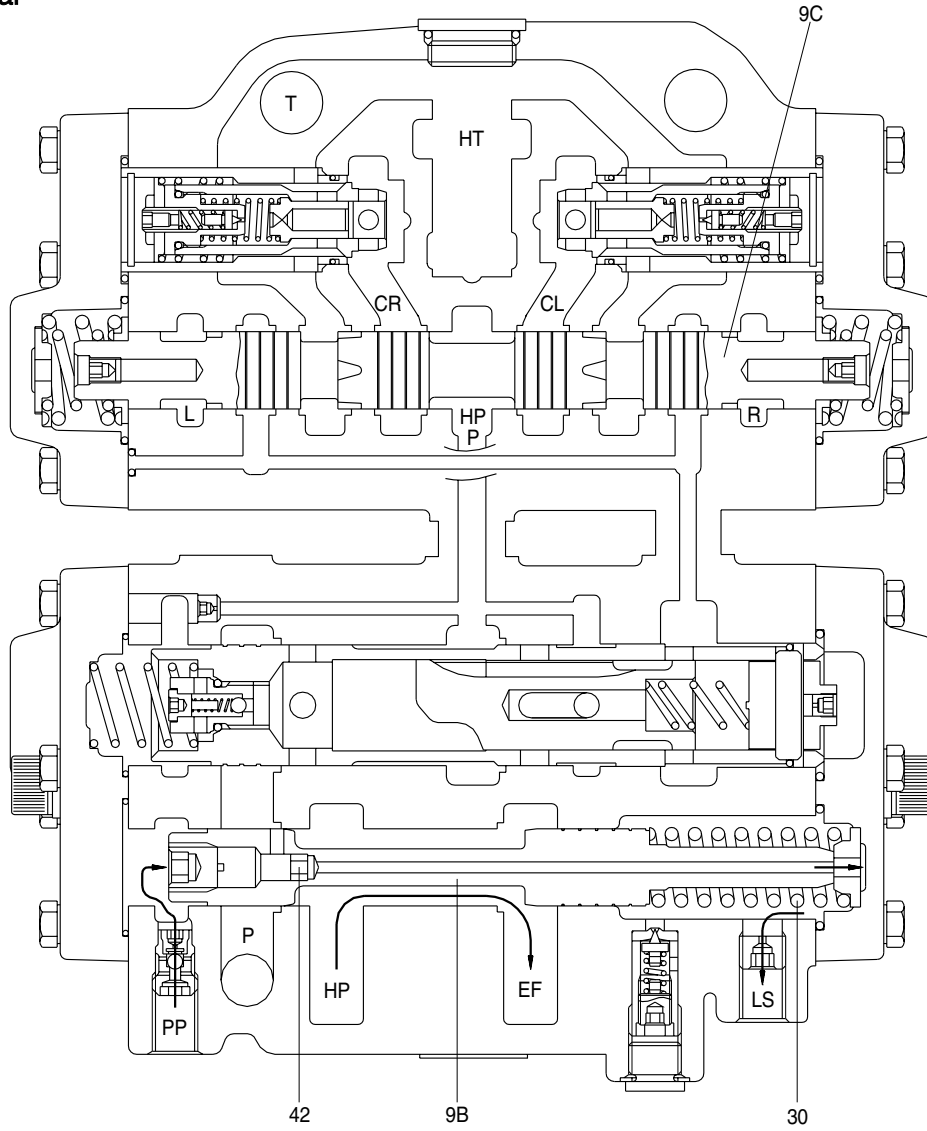

(770-3ATM) 5-8

In neutral position, the oil passes from the pump across the integrated priority valve(9B) in the flow amplifier for discharge through the EF port. With the steering unit in neutral, flow through it is blocked and all flow through the priority valve(9B) in flow amplifier is directed out the EF port to the loader control valve.

With the engine off, the priority valve spool(9B) is pushed to the left by the spring(30). The passage to the EF port is blocked while the passage to the P port is open.

When the machine is first started, all pump flow is routed to the steering unit which blocks the flow. With the flow blocked, the pressure increases.

Steering inlet pressure is supplied through the dynamic orifice(42) in the spool. This causes the priority valve spool(9B) to shift to the right against the spring(30) and open the EF port.

As long as the steering unit is in neutral, just enough pressure is maintained at the steering unit to keep the priority valve spool(9B) shifted to the right.

The operating pressure in the loader system has no effect on the operation of the priority valve(9B) of flow amplifier. With the loader actuated in relief, the priority valve(9B) will not shift until the machine is steered.

Flow through the priority valve spool(9B) passes from the P port through the orifice(42) and into the LS port. It flows through the steering unit LS passage which is routed to return when the steering unit is in neutral. This provides a warm-up circuit for the steering unit to prevent binding of the steering unit due to oil temperature extremes.

In neutral position, also the directional valve(9C) is in its center position.

This means that knock and impacts from the cylinder are not transmitted to the steering unit. The flow amplifier is thus of the non-reaction type.

(6) Mid-turn

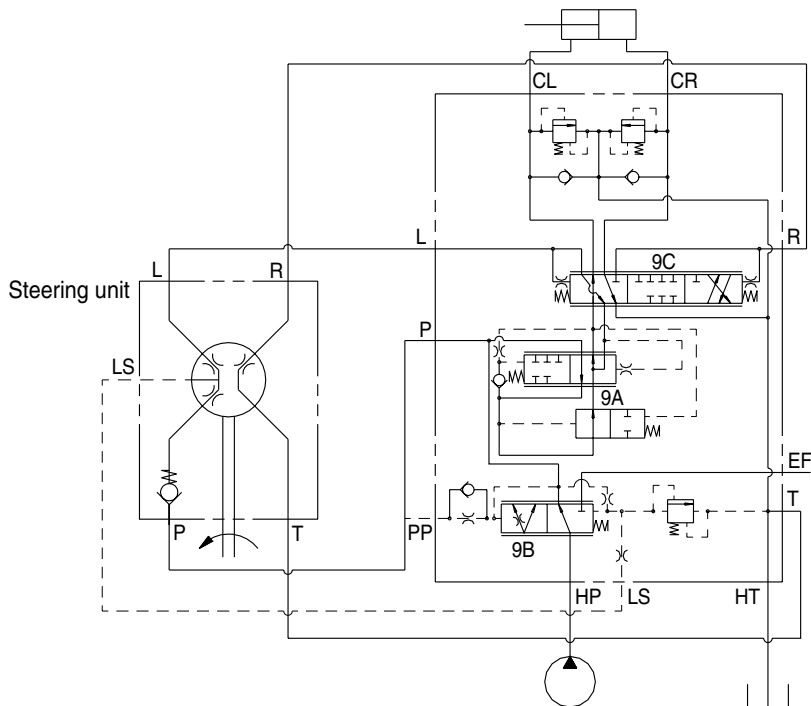
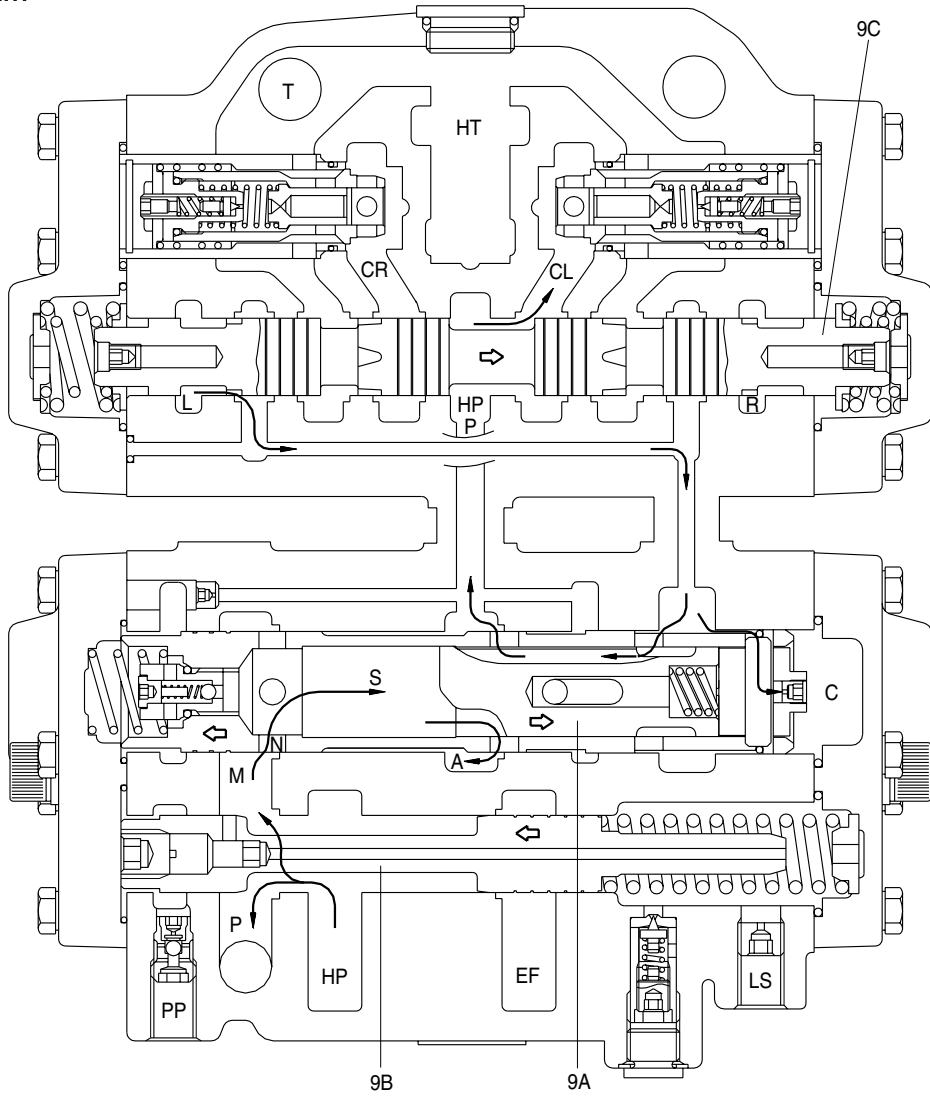

If the steering wheel is turned to the left, a LS signal is passed to the priority valve(9B). The priority valve(9B) is reversed so that more oil is passed across the P port to the steering unit for discharge through the L port of the flow amplifier.

The directional valve(9C) is reversed through the pressure being transmitted across the boring in the spool whereby the spool is moved the right.

The opening shall allow connection between the pilot flow and the pressure control/amplifier valve(9A).

The pilot pressure from the orifice in chamber C moves the valve to the left and passage for the pilot flow therefore is possible out of hole F.

The main flow passes from the priority valve(9B) to the circular channel M. As the amplifier spool is moved to the left, the passage will now be open across the holes N to the chamber S.

The spool goes to a position so that the pressure in chamber S equals the pressure in chamber C.

The passage is now open for the main flow through the priority valve(9B) across the holes A.

The main flow and pilot flow merge and is passed across the directional valve(9C) to the steering cylinder through CL port.

The return oil passes across the directional valve(9C) to the hydraulic tank.

(7) Full turn

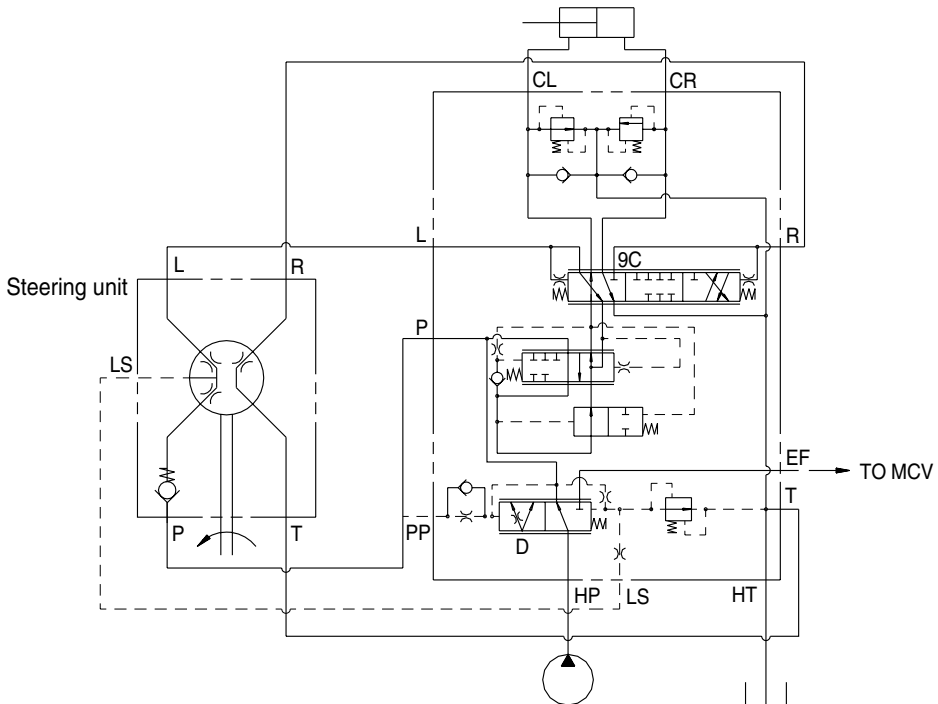
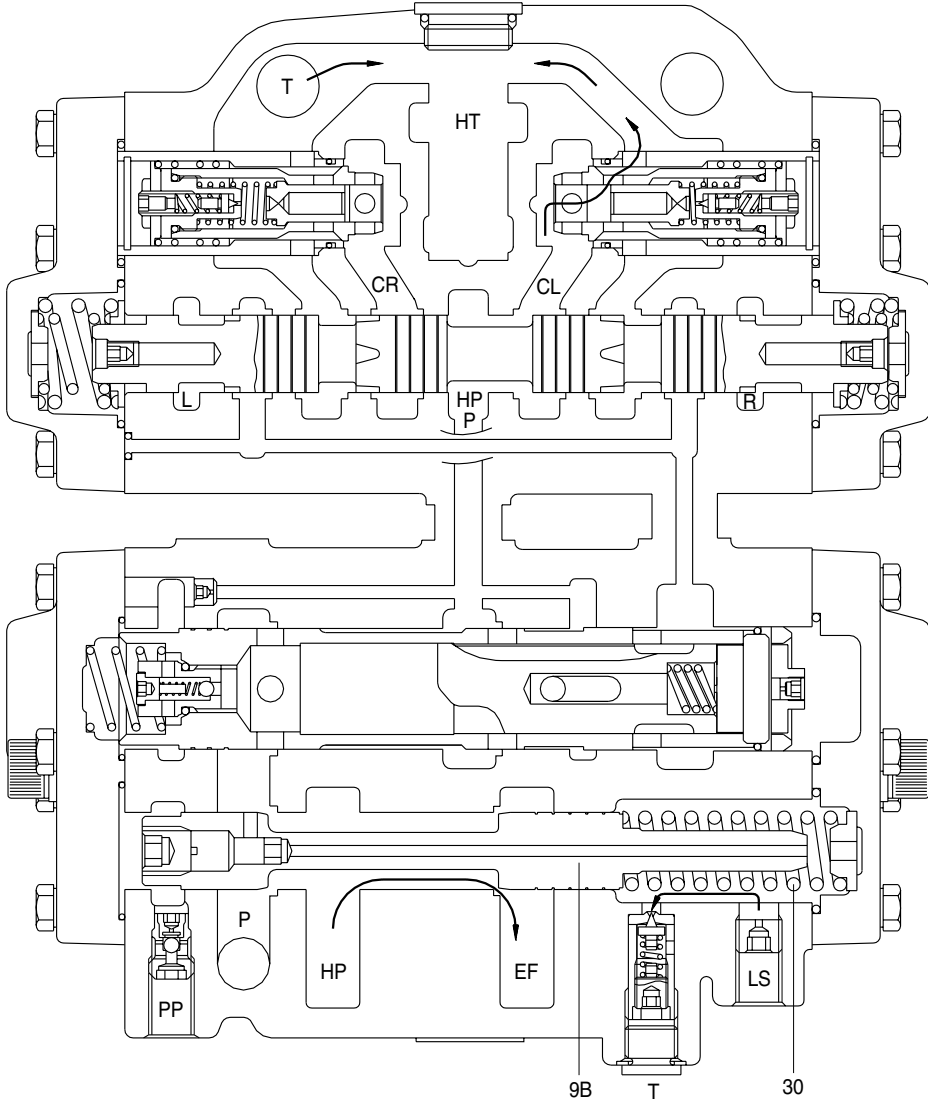

(770-3ATM) 5-12

When the machine is steered to a full turn, the frames bottom against the steering stops. To limit steering system pressure, a relief system is built into the priority valve assembly(9B).

When the frames bottom is stopped, the pressure in the steering cylinders increases. This pressure is sensed at the LS port. When the pressure in the LS port increases enough to push priority valve spool(9B) off its seat, oil in the load sensing circuit flows to return through the T port. Load sensing pressure is limited to the pressure setting of the relief valve.

Pressure to the steering unit(Pilot pressure), which is sensed at the left end of the priority valve spool(9B) in flow amplifier, continues to increase until it can move the spool to the right against the load sensing pressure plus spring(30) force. At this time, all oil flows out of the EF port to the loader control valve.

If the loader attachment is being operated while steering, the loader function will slow until the machine reaches the steering stops. At that time, the loader cycle speed will increase until the machine is steered again.

4. STEERING UNIT

1) STRUCTURE

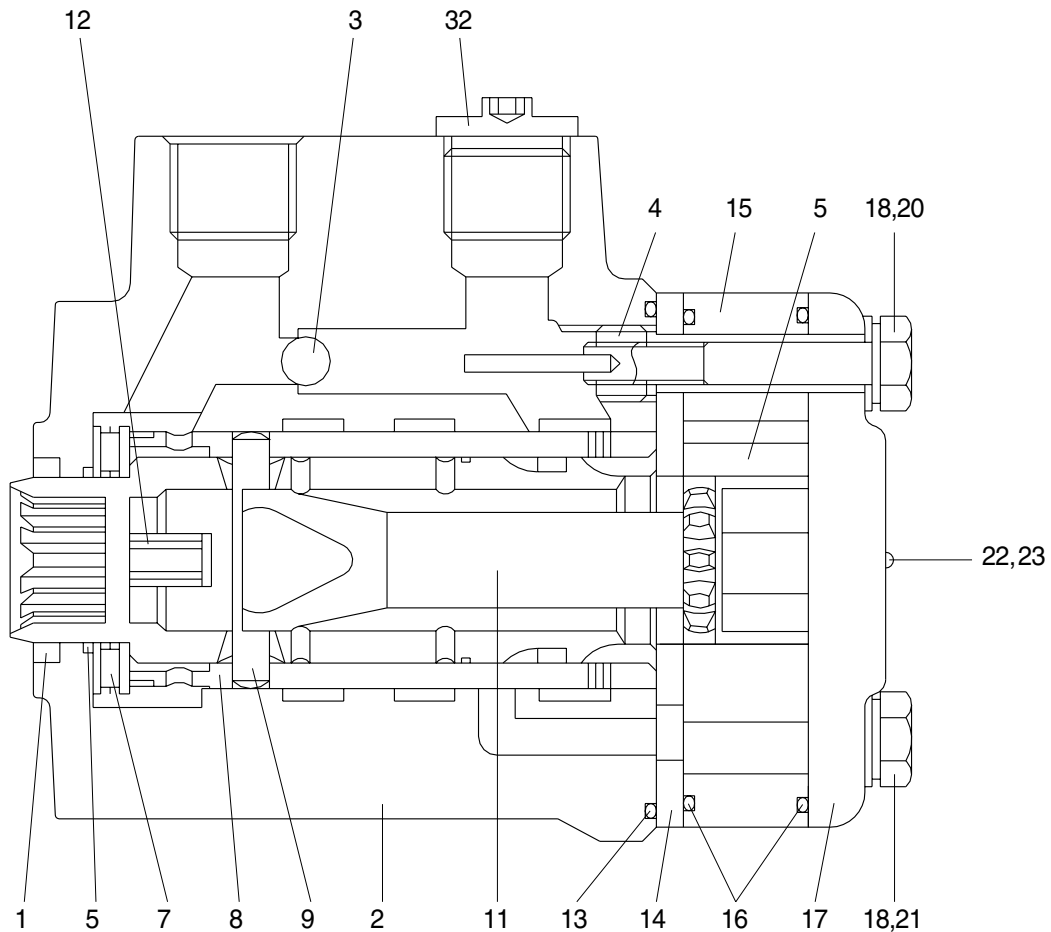

1	Dust seal ring	9	Cross pin	17	End cover
2	Housing, spool, sleeve	11	Shaft	18	Washer
3	Ball	12	Spring set	20	Pin screw
4	Bushing	13	O-ring	21	Screw
5	Lip seal	14	Distributor plate	22	Name plate
7	Bearing assy	15	Gearwheel set	23	Drive screw
8	Ring	16	O-ring	32	Check valve

(770-3ATM) 5-14

2) OPERATION

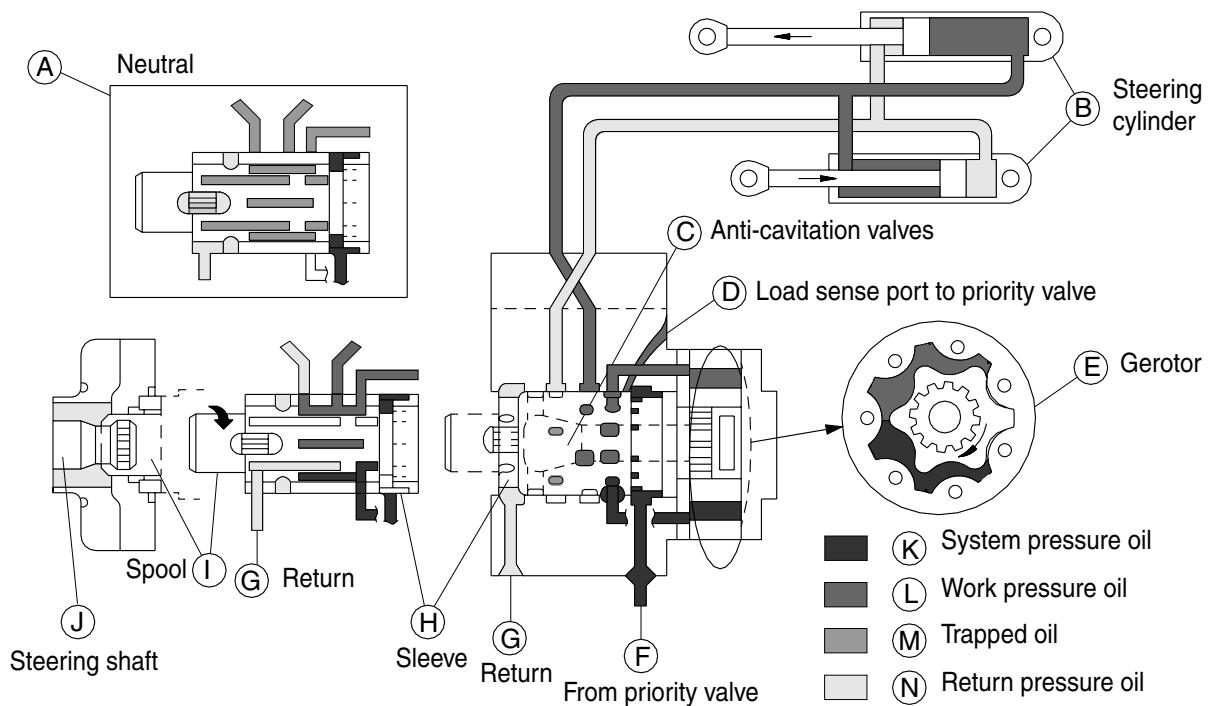

(770-3ATM) 5-15

The steering unit consists of a spool(I) inside a sleeve(H) within a housing. When steering wheel is not moving, the steering unit is in the neutral(A) position. In neutral, the spool and sleeve are aligned so that oil flow through the steering unit is blocked. The steering cylinder(B) are held stationary by trapped oil in the left and right workports.

When the steering unit is turned to the right, the spool rotates relative to the sleeve, and opens passages which allow pump flow through the spool and sleeve assembly. Oil flows to the gerotor(E) causing the gerotor gear to rotate. Oil flow from the gerotor flows back into the steering unit where it is directed out the right workport to the respective ends of the steering cylinders.

A bypass orifice is machined into the spool and sleeve assembly. It is a variable orifice that introduces a small leak into the pressure side of the steering unit. Its purpose is to dampen the initial pressure surge when the steering wheel is partially turned. When the steering wheel is fully turned, the leak is closed off.

Return oil flows back in through the left workport through the spool and sleeve assembly to return. The load sensing orifice is located between the sleeve and the gerotor. This orifice feeds the load sensing circuit between the steering unit and the priority valve of flow amplifier through the LS port.

When the rotation of the steering wheel stops, the gerotor gear continues to move, turning the sleeve, until the sleeve stops the flow to the gerotor. At this point, the steering unit is back in the neutral position and will remain there until the steering wheel is moved again.

The steering unit has a variable steering which is proportional to the speed the steering wheel is rotated. A variable orifice bypasses oil around the gerotor. Turning the steering wheel slowly takes approximately seven turn(Variable orifice small) lock to lock versus four turns(Variable orifice large) when turning the steering wheel quickly.

5. STEERING CYLINDER

1) STRUCTURE

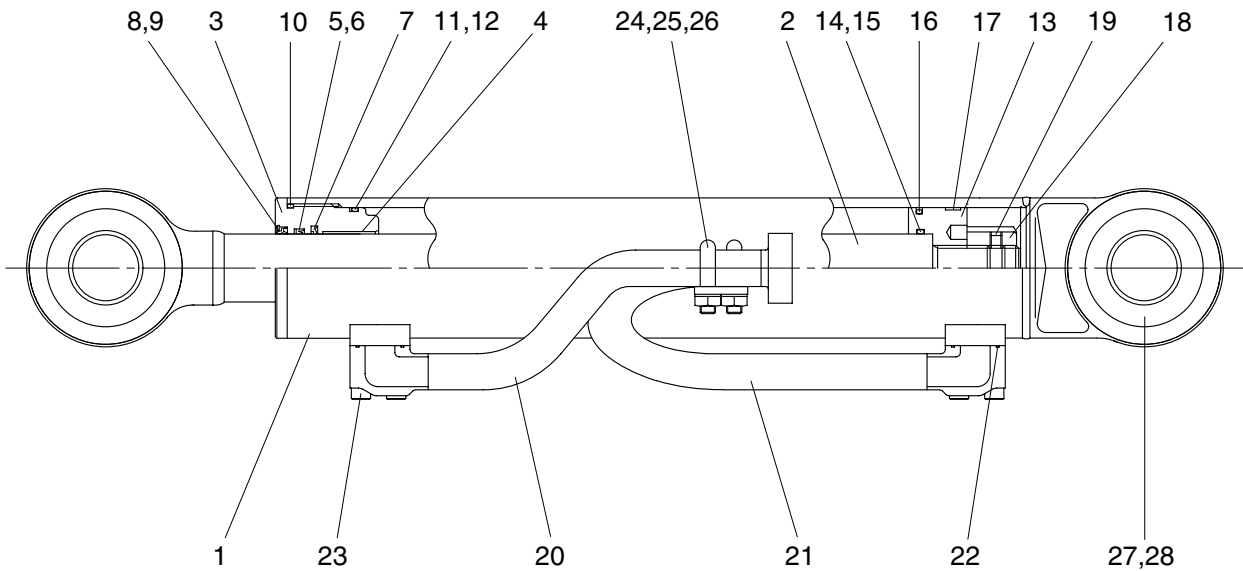

78035CY01

1	Tube assy	11	O-ring	21	Pipe assy
2	Rod assy	12	Back up ring	22	O-ring
3	Gland	13	Piston	23	Bolt
4	Bushing	14	O-ring	24	U-bolt
5	Rod seal	15	Back up ring	25	Nut
6	Back up ring	16	Piston seal	26	Spring washer
7	Buffer ring	17	Wear ring	27	Spherical bearing
8	Dust wiper	18	Piston nut	28	Retaining ring
9	Snap ring	19	Screw		
10	O-ring	20	Pipe assy		

2) OPERATION

This machine use to cross connected cylinder for steering operation.

The steering cylinder use a gland(3) to remove piston and sealed seals. Dust wiper(8) located on the in side of the gland protects cylinder inner parts from dust. The piston(13) is fastened to the rod(2) by a nut(18).

The piston uses a single wear ring(17) with a piston seal(16) to seal between the piston and tube. The gland seals against the tube with two O-rings(10, 11). The rod is sealed against the gland with a rod seal(5).