

SECTION 4 BRAKE SYSTEM

Group 1	Structure and Function	4-1
Group 2	Operational Checks and Troubleshooting	4-21
Group 3	Tests and Adjustments	4-29

SECTION 4 BRAKE SYSTEM

GROUP 1 STRUCTURE AND FUNCTION

1. OUTLINE

- ※ The brakes are operated by a pressure compensated, closed center hydraulic system.
Flow is supplied by a fixed displacement, gear type brake pump.

BRAKE SYSTEM

The fixed displacement brake pump supplies flow to the cut-off valve for service brake circuit and park brake circuits. It flows to four accumulator. The accumulator has a gas precharge and an inlet check valve to maintain a pressurized volume of oil for reserve brake applications.

Oil through the accumulator flows to the brake valves. The brake valve is a closed center design, dual circuit operated by a pedal.

The front and rear brakes will operate simultaneously with only one brake pedal depressed.

The differential contains annular brake piston and double sided disk.

Brake pump flow also goes to the parking brake solenoid valve in cut-off valve.

The brake system contains the following components:

- Brake pump
- Parking brake solenoid valve in cut-off valve
- Cut-off valve
- Brake valve
- Accumulators
- Pressure switches

FULL POWER HYDRAULIC BRAKE SYSTEM

ADVANTAGES - The full power hydraulic brake system has several advantages over traditional brake actuation systems. These systems are capable of supplying fluid to a range of very small and large volume service brakes with actuation that is faster than air brake systems. Figure represents a time comparison between a typical air/hydraulic and full power hydraulic brake actuation system.

Full power systems can supply significantly higher brake pressures with relatively low reactive pedal forces. The reactive pedal force felt by the operator will be proportional to the brake line pressure being generated. This is referred to as brake pressure modulation.

Another key design feature of full power systems is the ability to control maximum brake line pressure. In addition, because these systems operate with hydraulic oil, filtration can be utilized to provide long component life and low maintenance operation.

Because these systems are closed center, by using a properly sized accumulator, emergency power-off braking that is identical to power-on braking can be achieved. These systems can be either dedicated, where the brake system pump supplies only the demands of the brake system or non-dedicated, where the pump supplies the demands of the brake system as well as some secondary down stream hydraulic device.

Another important note is that all seals within these system must be compatible with the fluid medium being used.

**Response time
Full power brake actuation VS
Air/Hydraulic brake actuation**

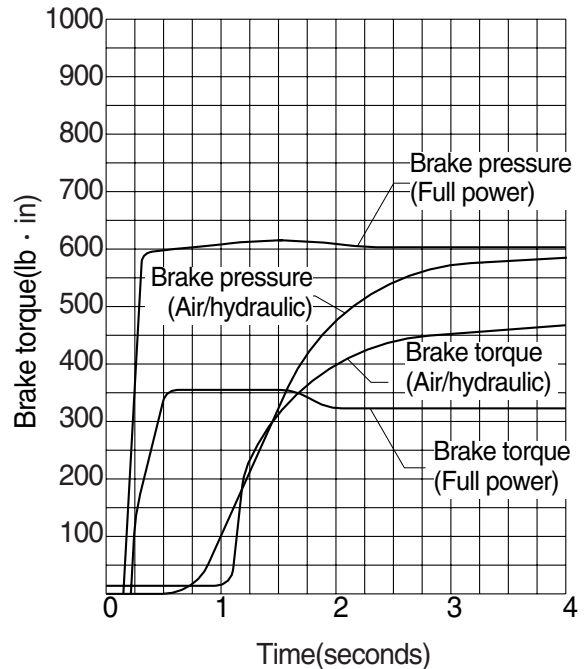

2. HYDRAULIC CIRCUIT

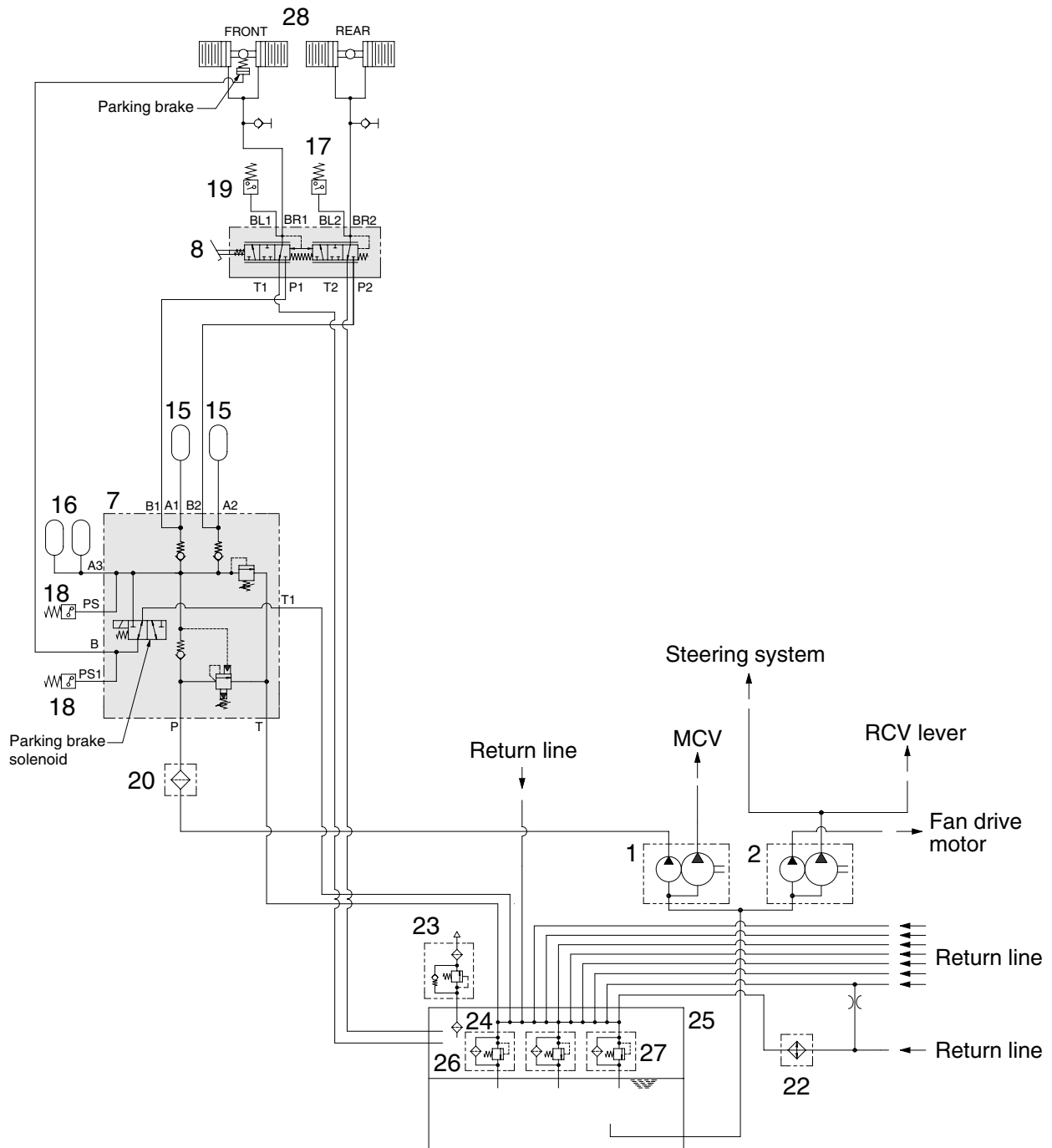

7807ABS01

- | | | | | | |
|----|--------------------------|----|-----------------|----|----------------|
| 1 | Main pump(+Brake pump) | 17 | Pressure switch | 24 | Strainer |
| 2 | Steering pump(+Fan pump) | 18 | Pressure switch | 25 | Hydraulic tank |
| 7 | Cut off valve | 19 | Pressure switch | 26 | Return filter |
| 8 | Brake valve | 20 | Line filter | 27 | Bypass valve |
| 15 | Accumulator | 22 | Oil cooler | 28 | Axle |
| 16 | Accumulator | 23 | Air breather | | |

1) SERVICE BRAKE RELEASED

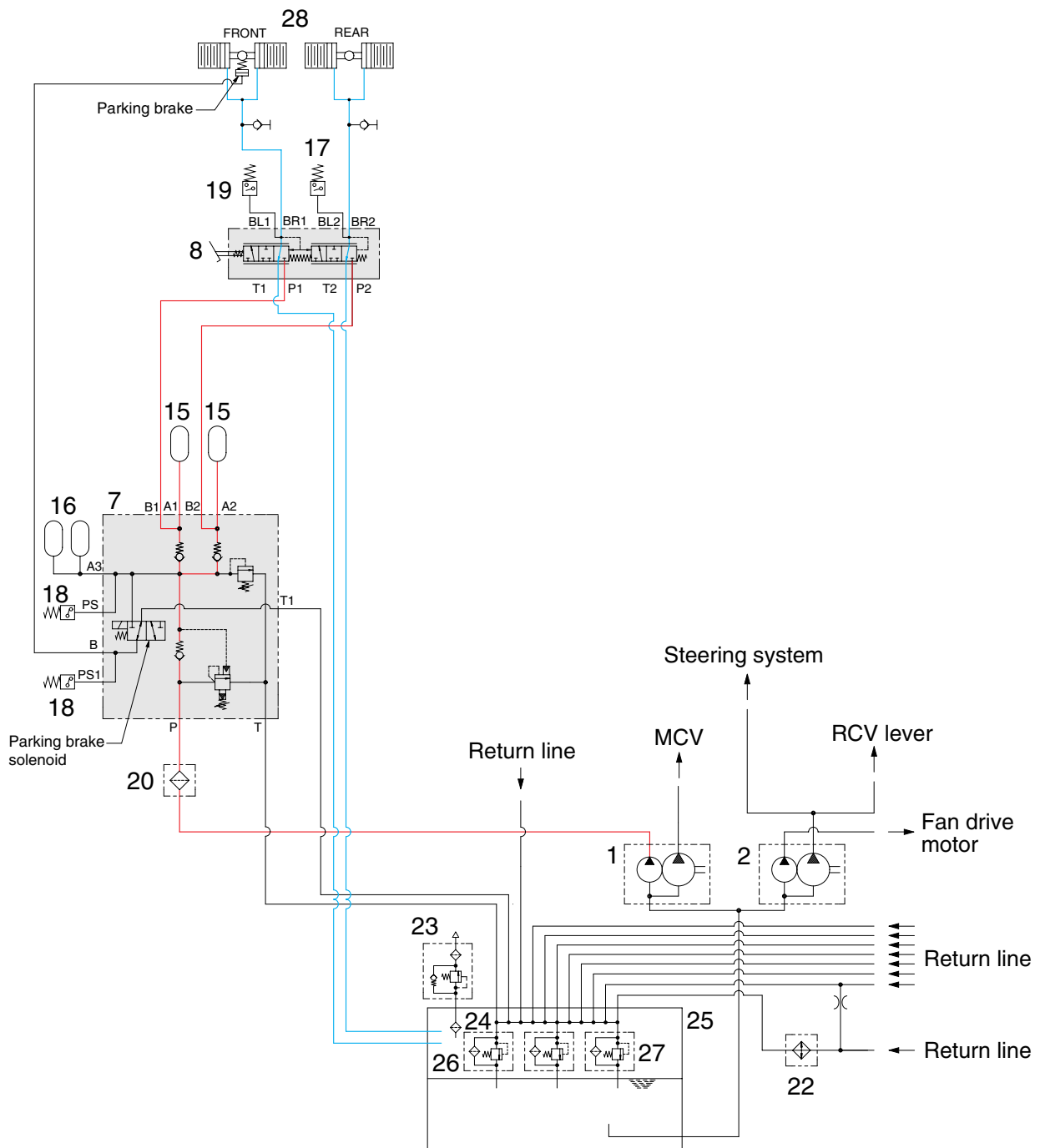

7807ABS02

When the pedal of brake valve(8) is released, the operating force is eliminated by the force of the spring, and the spool is returned.

When the spool removes up, the drain port is opened and the hydraulic oil in the piston of axles return to the tank(25).

Therefore, the service brake is kept released.

2) SERVICE BRAKE OPERATED

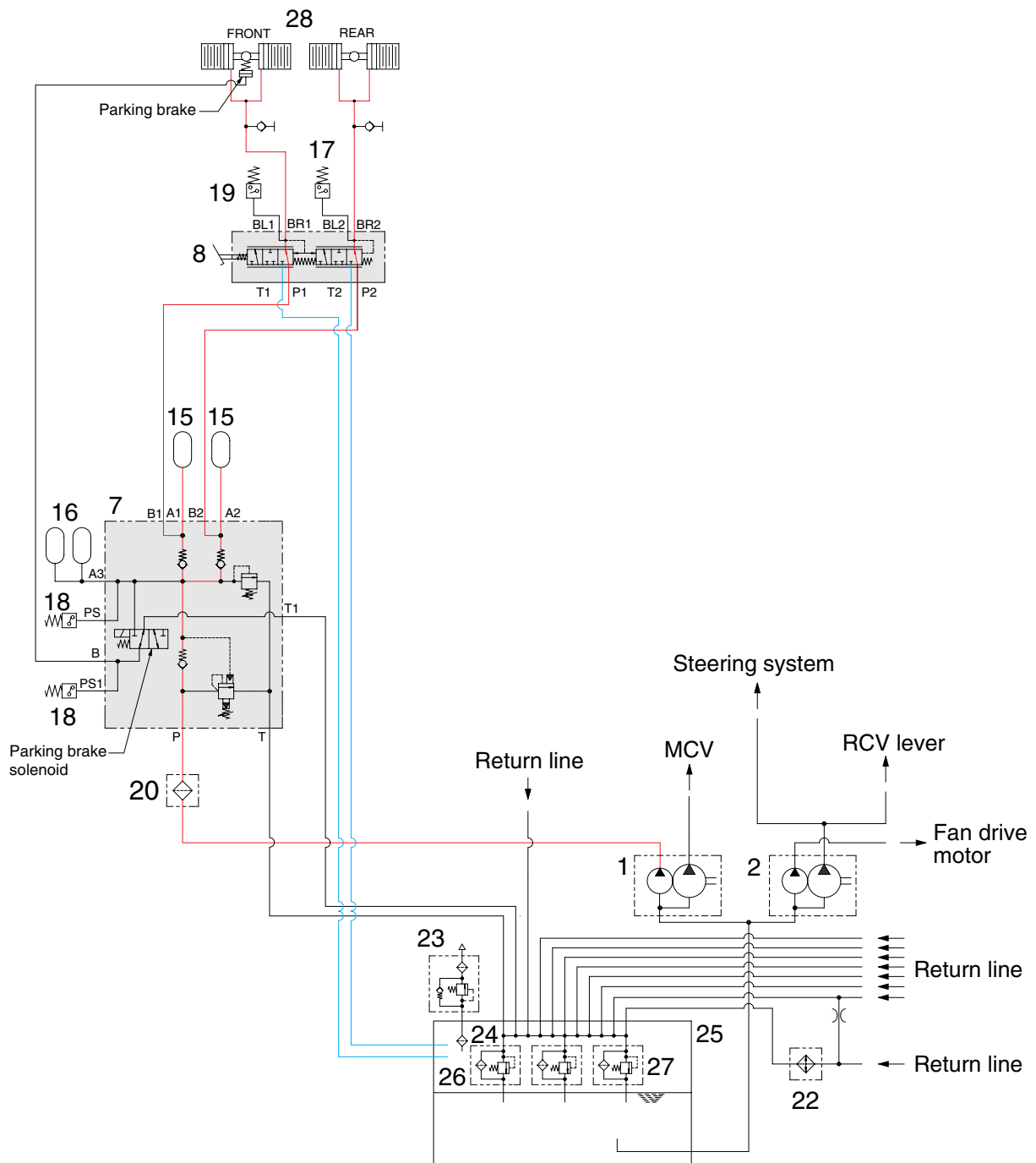

7807ABS03

When the pedal of brake valve(8) is depressed, the operating force overcomes the force of the spring, and is transmitted to the spool. When the spool moves down, the inlet port is opened, and at the same time the hydraulic oil controlled the pressure level by the cut-off valve(7) enters the piston in the front and rear axles. Therefore, the service brake is applied.

3) PARKING BRAKE RELEASED

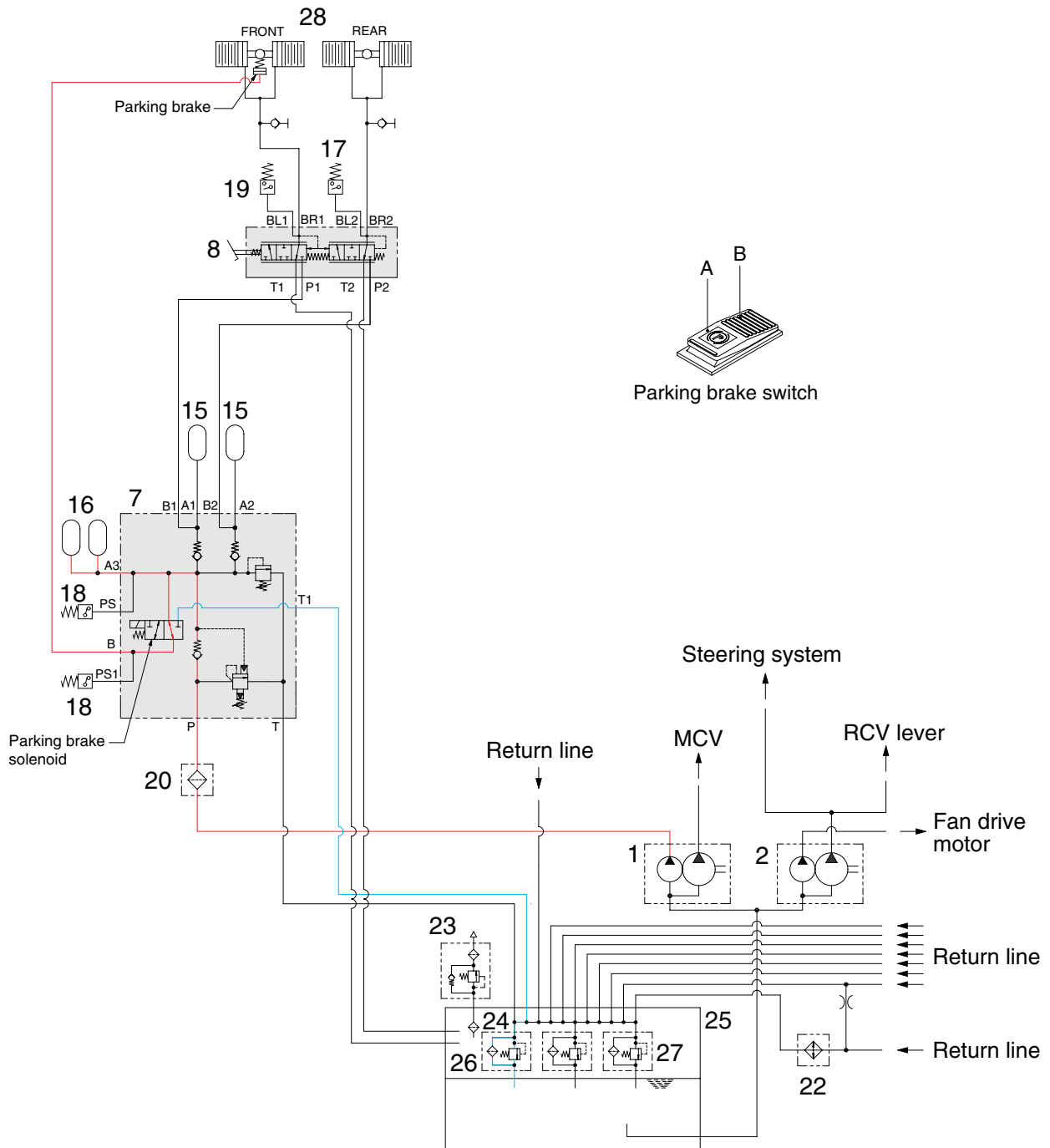

7807ABS04

When the parking brake switch is pressed B position, the solenoid valve is energized and the hydraulic oil controlled the pressure level by the cut-off valve(7) enters the parking brake on the front axle. It overcomes the force of the spring and pushes the piston rod. This releases the brake. Therefore, the hydraulic oil pressure is applied to the parking brake piston through the solenoid valve and the parking brake is kept released.

3. BRAKE PUMP

1) STRUCTURE

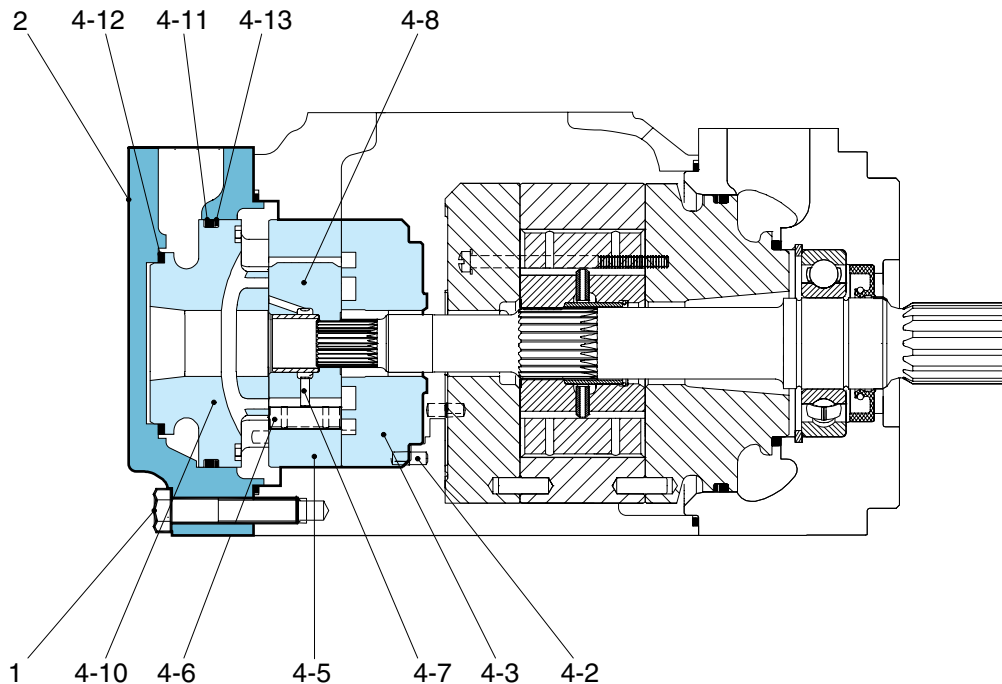

1	Cap screw	4-4	Dowel pin	4-9	Dowel pin
2	End cap	4-5	Cam ring	4-10	Pressure plate
4-2	Lock pin	4-6	Vane	4-11	Seal
4-3	Port plate	4-7	Vane holdout pin	4-12	Seal
		4-8	Rotor Assy	4-13	Back up ring

2) OPERATION

The pumping operation of this unit(each cartridge) is obtained by providing a fixed interior cam surface and a rotating inner member(rotor) containing vanes which held in contact with the inner cam surface. As the rotor is rotated by the drive shaft, the vanes are urged outward against the outward sloping cam surface, forming a cavity at the inlet ports of the port plates. Atmospheric pressure and suction created by the expanding cavity between the rotating vanes fill the inlet cavity with fluid.

As the rotation continues and the vanes that had previously moved outward and now have fluid trapped between them and the port plates, follow the inward slope of the cam which decreases the cavity containing the trapped fluid and discharges the fluid at system pressure through the pressure port openings in the port plates.

The rotating portion of the unitized cartridges feature the use of pressure actuated vanes which are urged against the cam ring by pins located in the bottom of each rotor vane slot. Initial force to bring the vanes in contact with the cam ring contour during start up is provided by centrifugal force. When pumping operation starts and pressure is established, fluid under pressure fills the pin cavity through the feed holes.

The feed holes open to the pressure port twice every revolution. All other times they are closed off by the port plate. This pressure under the pin provides the force necessary to keep the vanes in contact with the cam countour.

3) DISASSEMBLY AND ASSEMBLY : SEE page 6-58.

4. BRAKE VALVE

1) STRUCTURE

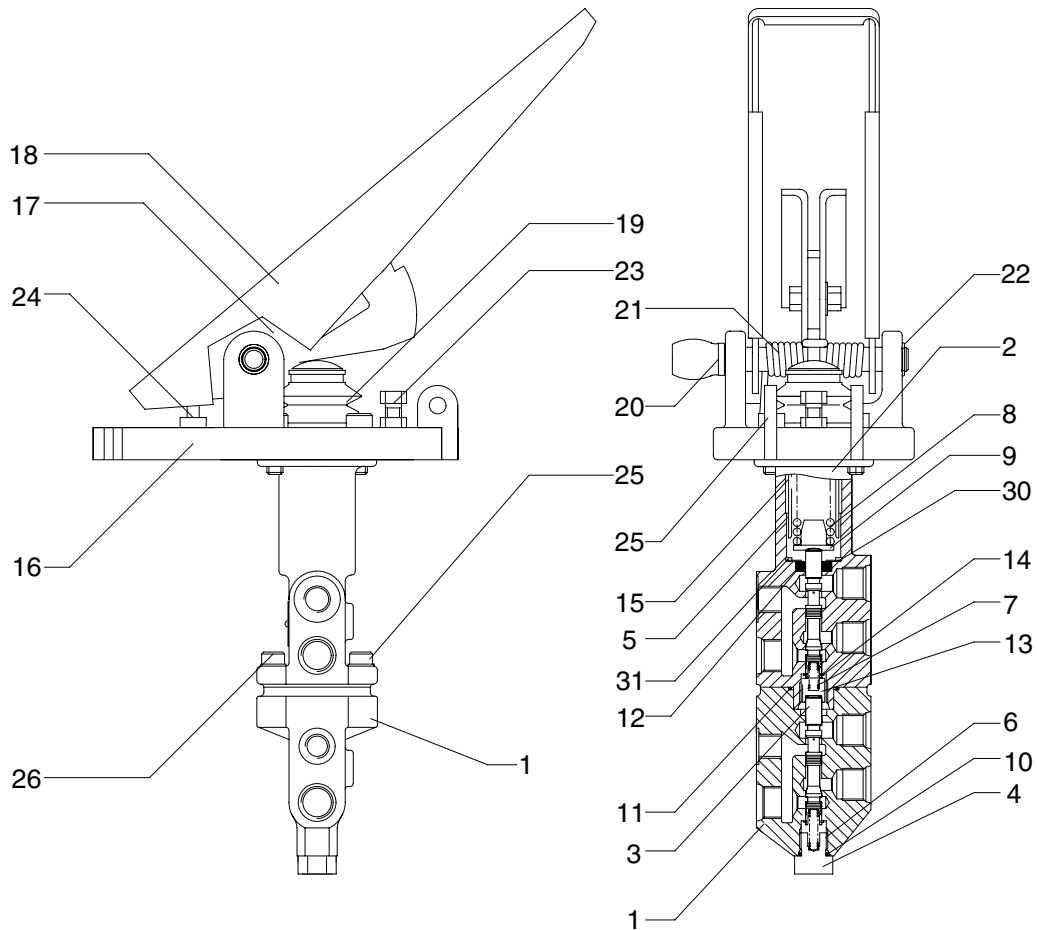

7807ABS21

1	Lower body	11	O-ring	21	Torsion spring
2	Upper body	12	Oil seal	22	Stop ring
3	Spool	13	Spring guide	23	Hexagon bolt
4	Plug	14	Stop ring	24	Hexagon nut
5	Holder	15	Bushing	25	Bolt
6	Lower spring	16	Pedal plate	26	Spring washer
7	Upper spring	17	Pedal assy	30	Plain washer
8	Main spring	18	Rubber(Pedal)	31	Stop ring
9	Spring retainer 1	19	Cover		
10	O-ring	20	Lock pin 1		

2) OPERATION

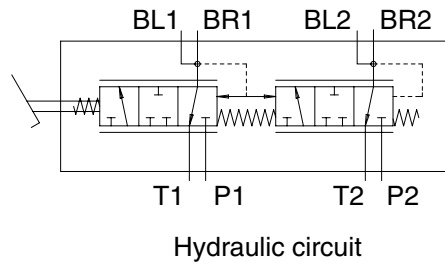
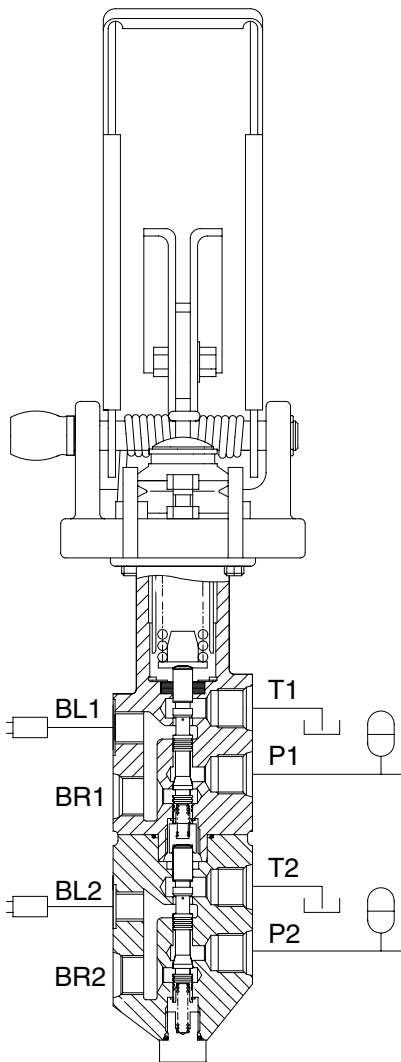

Porte	Port name	Port size
P1, P2	Port	PF3/8
T1, T2	Drain port	PF3/8
BR1, BR2	Brake cylinder port	PF3/8
BL1	Pressure switch port	PF1/4
BL2	Pressure switch port	M12 × 1.5

7807ABS22

(1) Purpose

The purpose of the brake valve is to sensitively increase and decrease the braking pressure when the brake pedal is actuated.

(2) Ready position

When the braking system is ready for operation, its accumulator pressure acts directly on ports (P1, P2) of the brake valve. A connection is established between ports(BR1, BR2) and ports(T1, T2) so that the wheel brakes ports(BR1, BR2) are pressureless via the returns ports(T1, T2).

(3) Partial braking

When the brake valve is actuated, an amount of hydraulic pressure is output as a ratio of the foot force applied.

The spring assembly(8) beneath base plate(16) is designed in such a way that the braking pressure changes depending on the angle. In the lower braking pressure range, the machine can be slowed sensitively.

When the braking process is commenced, the upper spool is mechanically actuated via spring assembly(8), and the lower spool is actuated hydraulically by spool. As spools(3) move downward, they will first close returns(T1, T2) via the control edges, thus establishing a connection between accumulator ports(P1, P2) and ports(BR1, BR2) for the wheel brake cylinders. The foot force applied now determines the output braking pressure. The control spools(3) are held in the control position by the force applied(Spring assembly above the spools and the hydraulic pressure below the spool(Balance of forces).

After output of the braking pressure, spools(3) are in a partial braking position, causing ports(P1, P2) and ports(T1, T2) to close and holding the pressure in ports(BR1, BR2).

(4) Full braking position

When pedal is fully actuated, end position of the brakes is reached and a connection established between accumulator ports(P1, P2) and brake cylinder ports(BR1, BR2). Returns(T1, T2) are closed at this point.

When the braking process is ended, a connection is once again established between brake cylinder ports(BR1, BR2) and return ports(T1, T2), closing accumulator ports(P1, P2).

The arrangement of spools in the valve ensures that even if one braking circuit fails the other remains fully operational. This is achieved by means of the mechanical actuation of both spools and requires slightly more pedal travel.

(5) Limiting the braking pressure

Pedal restriction bolt(23) on base plate below pedal is used to limit the braking pressure.

(6) Failure of a circuit

In the event of the lower circuit failing, the upper circuit will remain operational. Spring assembly (8) will mechanically actuate spool. In the event of the upper circuit failing, the lower circuit will remain operational since the lower spool(31) is mechanically actuated by spring assembly(21) and spool.

(7) Installation requirements

Return lines(T1, T2) must be connected directly to the tank.

The connecting lines must be installed in such a way as to permit proper bleeding.

(8) Maintenance of the brake valve

No special maintenance beyond the legal requirements is necessary.

When using high-pressure cleaners on the machine, please make sure that the water jet is not aimed directly at the brake valve (To prevent damaging the bellows).

△ **For safety reasons the whole of the brake valve must be replaced if parts other than those listed above are damaged.**

(9) Repair work

△ **When working on the braking system, always make sure that there is absolutely no pressure in the system. Even when the engine is switched off there will be some residual pressure in the system.**

※ **When doing repair work, make sure your environment is very clean.**

Immediately close all open ports on the components and on pipes using plugs.

(10) Replacing the pedal cover

Pedal cover(18) is simply pulled off by hand. The new pedal cover is pushed over pedal(17) and tightened manually. Fasten the bellows with the strap retainers.

(11) Replacing the complete actuating mechanism

Carefully clamp the unit vertically in a fixture. The actuating mechanism can be removed by taking out the four bolts. Make sure that spring assembly(8) does not fall out. When installing the new actuating mechanism, make sure that spring assembly(8) is fitted in the right order. Tighten the four bolts(25).

(12) Replacing the bellows

To change bellows(19) it is advisable to remove pedal(17). For this purpose, loosen retaining ring (22) and knock out pin(20) using a mandrill. When knocking out the bolt, make sure that the mandrill is applied to the side of the bolt without a knurl. Remove pedal(17) and bellows(19).

Now fit the new bellows and proceed in reverse order as described above. The upper portion of bellows is fastened to piston, its lower portion to base plate(16) secure the bellows using clamps.

5. CUT-OFF VALVE

1) STRUCTURE

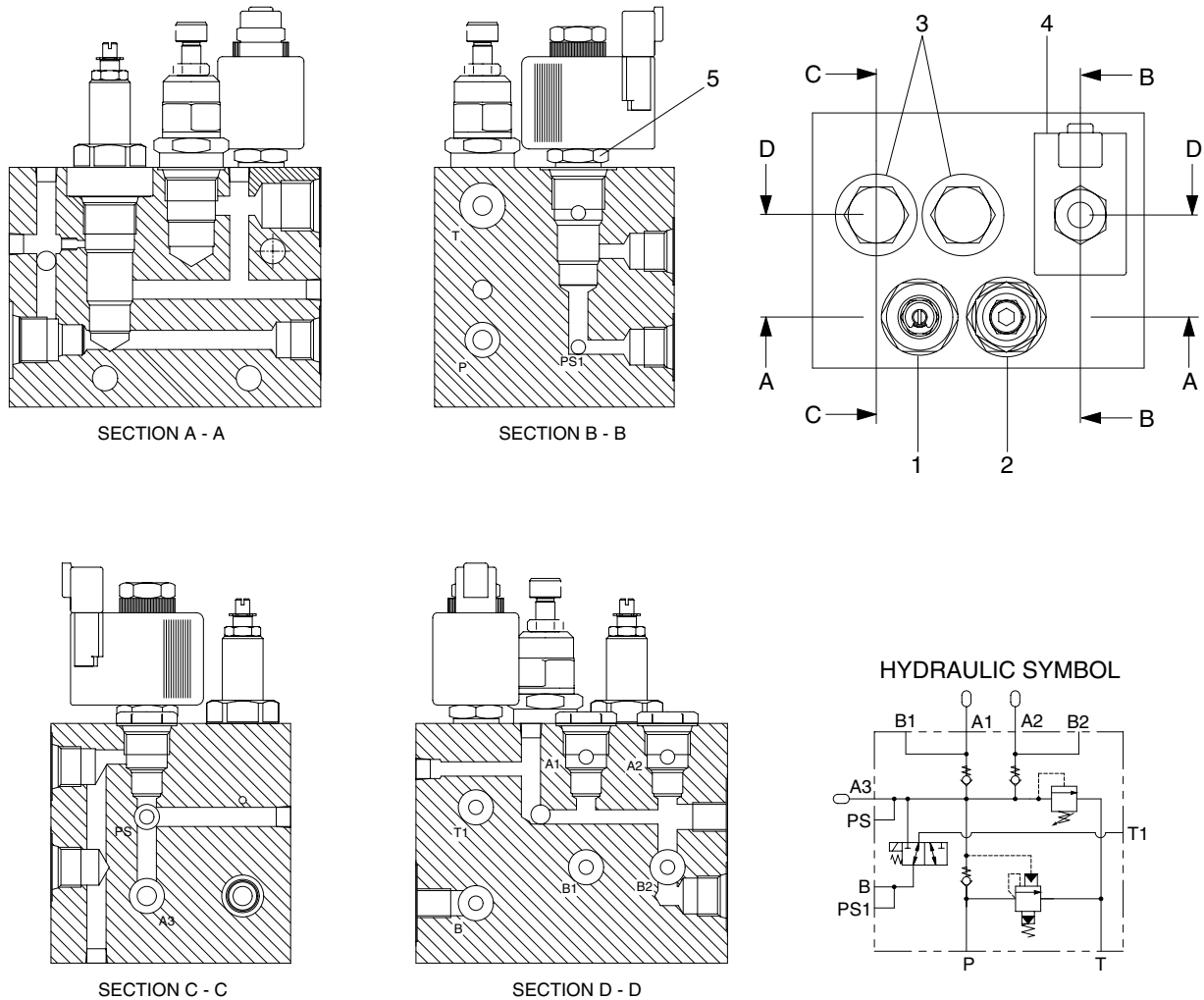

- 1 Cut-off valve
- 2 Relief valve
- 3 Check valve

- 4 Coil
- 5 Solenoid valve

2) OPERATION

When the pump works, the oil under the pressure flows into P port.

The oil in P port is stored in the accumulator on A3 port.

As the pressure on P line rises to 150bar, the cut off valve(1) starts cut-offting and the oil in the P port is unloaded. The pressure on P line goes down 120bar by the minute leakage from valve and other factors.

At this pressure, the cut-off valve starts cut-ining.

This process is repeated in the regular period of 30~40 seconds.

7707BS06

6. BRAKE ACCUMULATOR

1) STRUCTURE

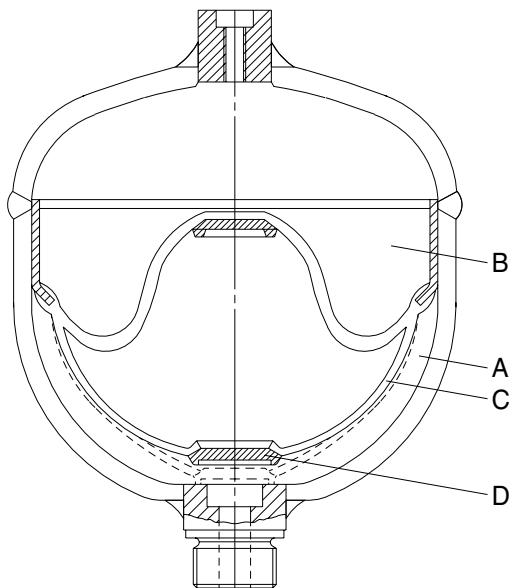

(770-3ATM) 4-22

Item	81L1-0004 (Item16)	81L1-0003 (Item15)
Diameter	121mm	136mm
Mounting height	146mm	160mm
Norminal volume	0.75m ³	1.0m ³
Priming pressure	50kgf/cm ²	50kgf/cm ²
Operating medium	Oil	Oil
Operating pressure	Max 210kgf/cm ²	Max 200kgf/cm ²
Thread	M18 × 1.5	M18 × 1.5
Priming gas	Nitrogen	Nitrogen

A Fluid portion
B Gas portion

C Diaphragm
D Valve disk

2) OPERATION

(1) Purpose

Fluids are practically incompressible and are thus incapable of accumulating pressure energy. In hydropneumatic accumulators, the compressibility of a gas is utilized to accumulate fluid. The compressible medium used in the accumulators is nitrogen.

In braking systems, the purpose of the accumulators is to store the energy supplied by the hydraulic pump. They are also used as an energy reserve when the pump is not working, as a compensator for any losses through leakage, and as oscillation dampers.

(2) Operation

The accumulator consists of a fluid portion (A) and a gas portion (B) with a diaphragm (C) as a gas-tight dividing element. The fluid portion (A) is connected to the hydraulic circuit, causing the diaphragm accumulator to be filled and the gas volume to be compressed as the pressure rises.

When the pressure falls, the compressed gas volume will expand, thus displacing the accumulated pressure fluid into the circuit.

The diaphragm bottom contains a valve disk (D) which, if the diaphragm accumulator is completely empty, closes the hydraulic outlet, thus preventing damage to the diaphragm.

(3) Installation requirements

The accumulators can be fitted in the hydraulic circuit, directly on a component or in blocks on suitable consoles.

They should be fitted in as cool a location as possible.

Installation can be in any position.

(4) Maintenance of the accumulator

No special maintenance beyond the legal requirements is necessary.

The accumulator should be checked annually. It should be replaced if the initial gas pressure has fallen by more than 30% (Please refer to **Performance testing and checking of the accumulator**).

(5) Disposal of the accumulator

Before the accumulator is scrapped, its gas filling pressure must be reduced. For this purpose, drill a hole through gas chamber (B) using a drill approx. 3mm in diameter. The gas chamber is located on the side opposite the threaded port above the welding seam around the center of the accumulator.

※ **Wear safety goggles when doing this job.**

(6) Performance testing and checking of the accumulator

The accumulator is gradually pressurized via the test pump; until the initial gas pressure is reached, the hydraulic pressure in the accumulator will rise abruptly. This is apparent from gauge **M**. If the initial gas pressure is more than 30% below the prescribed value, the accumulator needs to be replaced. If the measuring process needs to be repeated, wait for intervals of 3 minutes between the individual tests. Any accumulator whose initial gas pressure is insufficient must be scrapped following the instructions under **Disposal of the accumulator**.

The amount of initial gas pressure can also be checked from the vehicle. Start the vehicle's engine. The pump will now supply oil to the accumulators. Until the initial gas pressure is reached, the hydraulic pressure in the accumulator will rise abruptly. This is apparent from the gauge in the cab. If the initial gas pressure is more than 30% below the prescribed value, that initial pressure lies outside the permissible range for **at least one** of the accumulators fitted in the vehicle. This accumulator can be traced only by using the method described above, i.e. all accumulators have to be individually tested. The accumulator whose initial gas pressure is insufficient must be replaced and scrapped following the instruction under **Disposal of the accumulator**.

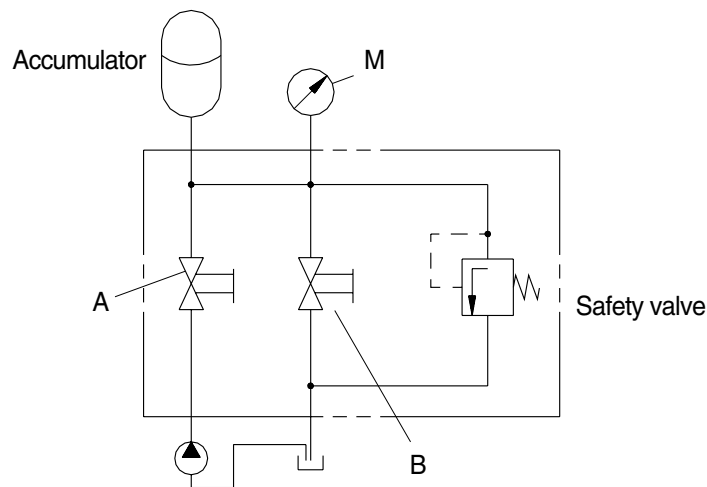

(7) Repair work

- △ **When working on the braking system, always make sure that there is absolutely no pressure in the system. Even when the engine is switched off there will be some residual pressure in the system.**
- ※ **When doing repair work, make sure your environment is very clean.
Immediately close all open ports on the components and on pipes using plugs.**
- △ **For safety reasons the accumulators need to be replaced as a whole if damaged.**

7. PRESSURE SWITCHES

1) STRUCTURE

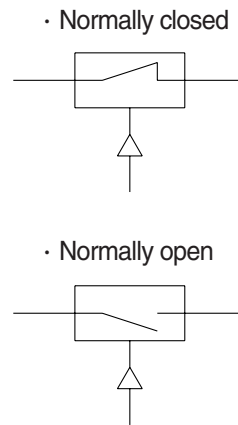
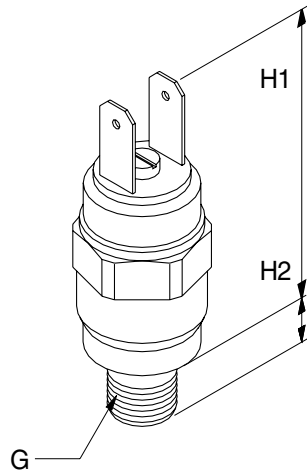

(770-3ATM) 4-25

· Technical data

Item	Type	Medium	G	H1 mm	H2 mm	Adjusting range kgf/cm ²	Adjusting pressure kgf/cm ²	Voltage V
Charging/Parking	NC	Oil	M12×1.5	55	9	50 ~ 150	100 ± 10	Max 42
Brake stop	NO	Oil	M12×1.5	55	9	1 ~ 10	5 ± 1	Max 42
Clutch cut-off	NO	Oil	PF 1/4"	55	9	20 ~ 50	24 ± 2	Max 42

NC : Normally closed

NO : Normally open

2) OPERATION

(1) Purpose

The pressure switches are used to visually or audibly warn the driver of the pressure within the system.

(2) Make contact / circuit closer

The pressure switch can be fitted in the braking system or directly on one of its components. The system pressure acts on an absorption area within the switch, making an electrical contact as the pressure on that area is increased. The resulting current is used to activate a warning facility, for instance.

(3) Break contact / circuit breaker

The pressure switch can be fitted in the braking system or directly on one of its components. The system pressure acts on a absorption area within the switch, breaking an electrical contact as the pressure on that area is increased. The current is now broken, e.g. to deactivate a warning facility.

(4) Installation requirements

No special measures need to be taken.

(5) Maintenance of the pressure switch

No special maintenance beyond the legal requirements is necessary.

When using high-pressure cleaners on the vehicle, please make sure that the water jet is not directed at the pressure switch (Corrosion of contacts).

(6) Repair work

- △ **When working on the braking system, always make sure that there is absolutely no pressure in the system. Even when the engine is switched off there will be some residual pressure in the system.**
- ※ **When doing repair work, make sure your environment is very clean. Immediately close all open ports on the components and on pipes using plugs.**
- ※ **For safety reasons the pressure switch needs to be replaced as a whole if damaged.**

(7) Adjusting and testing pressure switch

The adjusting screw located between the two contact plugs can be set to the desired value within a certain range. For adjusting range, please refer to the table **Technical data** on the previous page.

After making the adjustment, the adjusting screw should be secured using wax or a similar material.

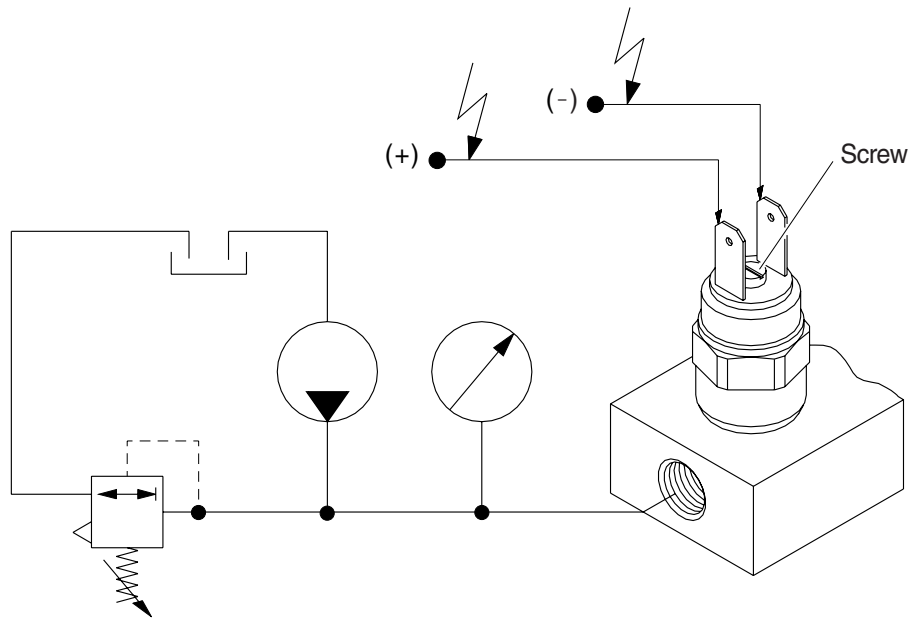

(770-3ATM) 4-25

8. PARKING BRAKE

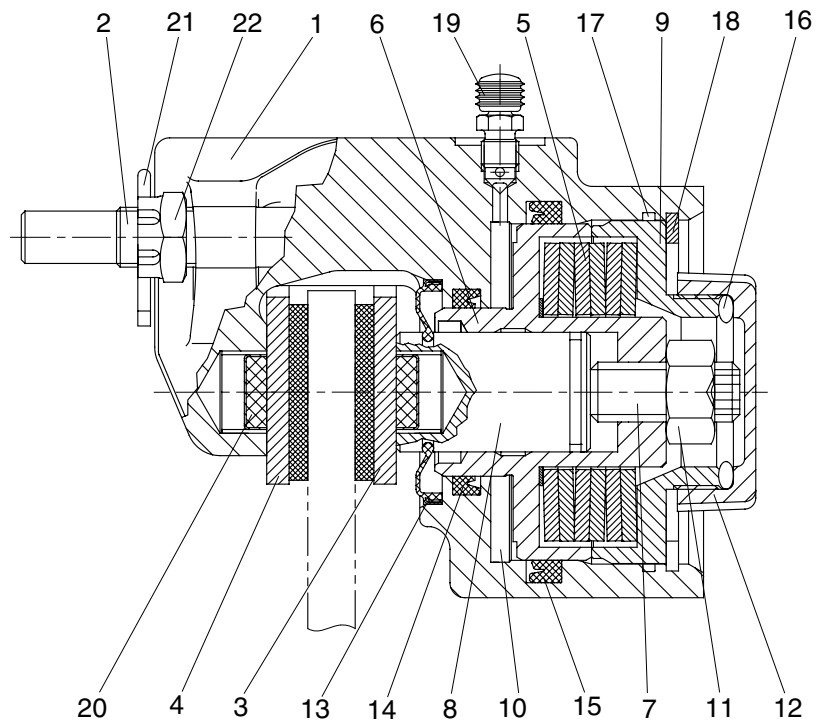

7807APB01

- | | | | | | |
|---|-----------------|----|---------------------|----|-----------------|
| 1 | Housing | 9 | Pressure ring | 17 | Seals |
| 2 | Guide bolt | 10 | U-ring | 18 | Circlip |
| 3 | Brake pads | 11 | Lock nut | 19 | Bleeding valve |
| 4 | Brake pads | 12 | Screw cap | 20 | Clearance ring |
| 5 | Cup springs | 13 | Dust protection cap | 21 | Locking splint |
| 6 | Piston | 14 | Seal rings | 22 | Castellated nut |
| 7 | Adjusting screw | 15 | Seal rings | | |
| 8 | Pressure bolt | 16 | O-ring | | |