

GROUP 4 DISASSEMBLY AND ASSEMBLY

1. ELECTRO-HYDRAULIC CONTROL UNIT

1) DISASSEMBLY

(1) Loosen socket head screws and remove selector housing.

※ Special tool

Box spanner TX-27 5873 042 002



Figure 1

(2) Separate hose lines from the intermediate plate. Loosen socket head screws and separate intermediate plate as well as gaskets and intermediate sheet from gearbox housing.

※ Special tool

Box spanner TX-40 5873 042 004



Figure 2

(3) Mark installation position of the cable harness to the valve block.

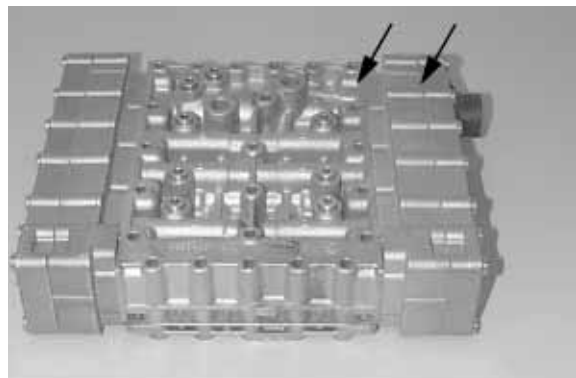

Figure 3

- (4) Loosen socket head screws.
Separate duct plate, gaskets and intermediate sheet from the valve block.

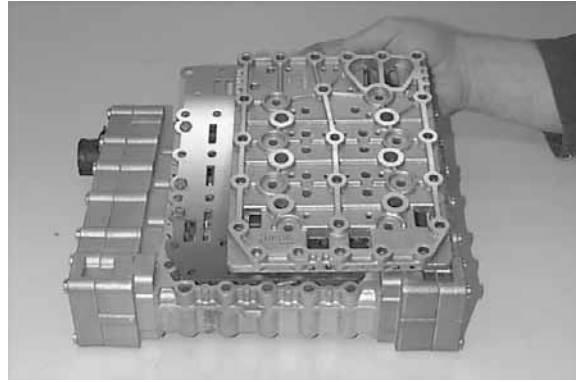

Figure 4

- (5) Remove retaining clip.

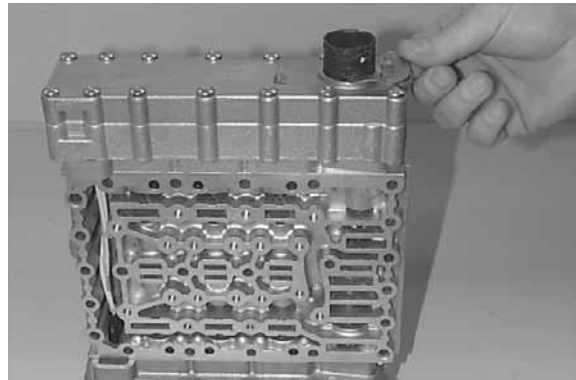

Figure 5

- (6) Loosen socket head screws and remove cover. Demount opposite cover.

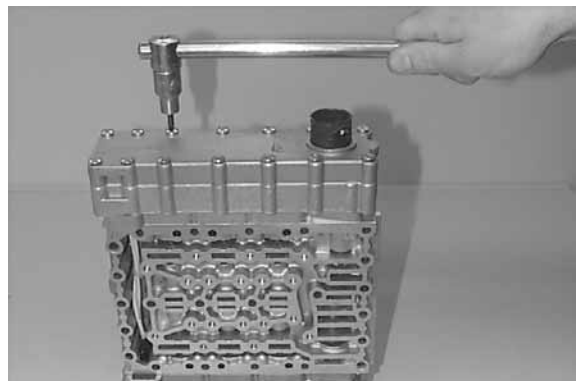

Figure 6

- (7) Demount pressure regulator and remove cable harness.

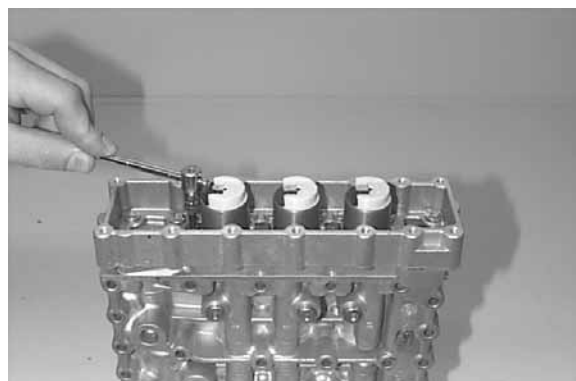

Figure 7

(8) Loosen socket head screws, remove retaining plates and demount pressure regulator.

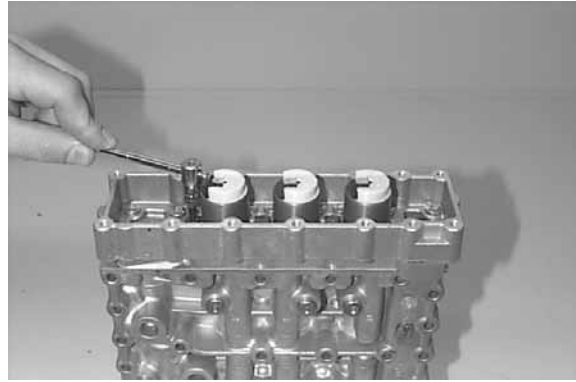

Figure 8

(9) Loosen two socket head screws and locate the housing provisionally by means of adjusting screws.

(Housing is spring-loaded)

Now, loosen the remaining socket head screws.

- ※ Special tool
- Adjusting screws 5870 204 036

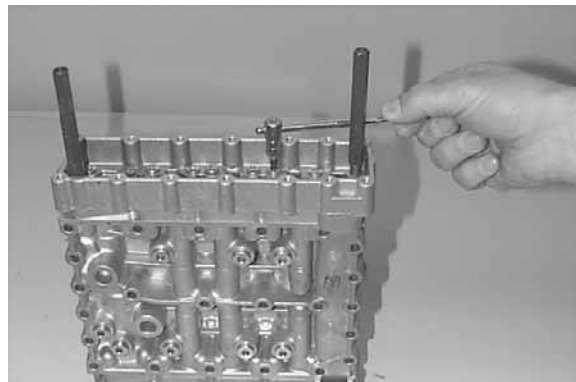

Figure 9

(10) Separate housing from valve body by uniform loosening of the adjusting screws.

- ※ Special tool
- Adjusting screws 5870 204 036

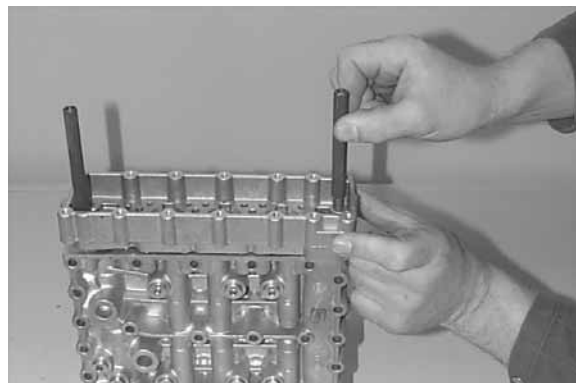

Figure 10

(11) Remove components.

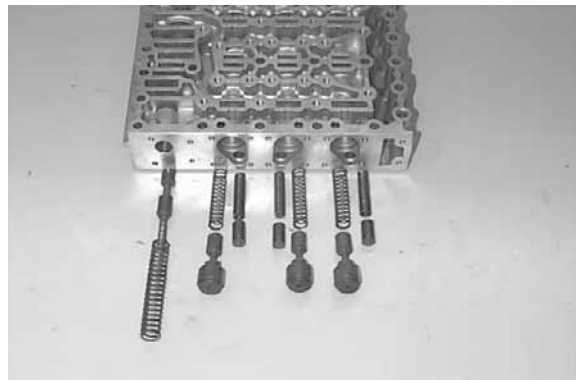

Figure 11

(12) Remove opposite pressure regulators, housing as well as components accordingly.



Figure 12

2) ASSEMBLY

※ Check all components for damage and renew if necessary. Prior to the installation, check the free travel of the moving parts in the housing. Spools can be exchanged individually. Prior to the assembly, oil the components.

(1) Insert orifices with the concave side showing upward, until contact is obtained.

※ Installation position, see Arrows.

(2) The figure on the right shows the following components :

- 1 Vibration damper(3x spool and compression spring)
- 2 Follow-on slide(3x spool and compression spring)
- 3 Pressure reducing valve(1x spool and compression spring)

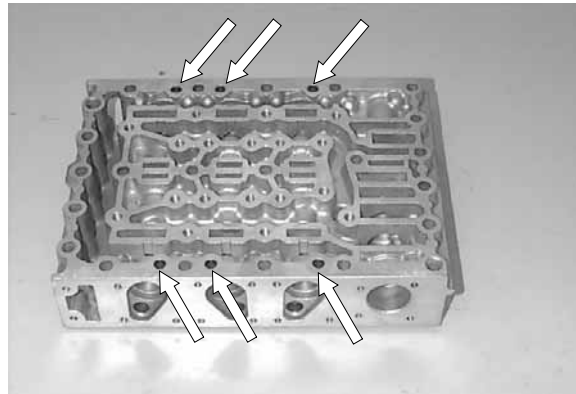

Figure 13

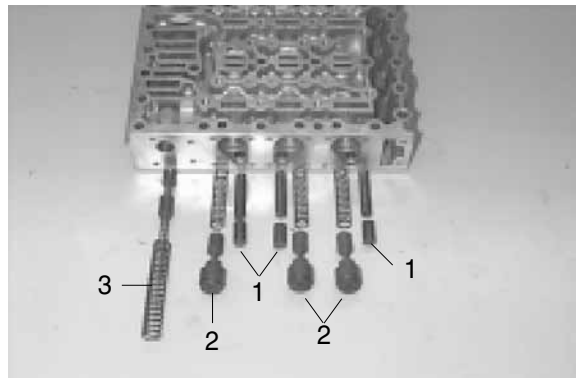

Figure 14

(3) Install components according to Figure 14.

※ Preload the compression springs of the follow-on slides and locate the spools provisionally by means of cylindrical pins $\varnothing 5.0\text{mm}$ (assembly aid), see Arrows/ Figure 15.

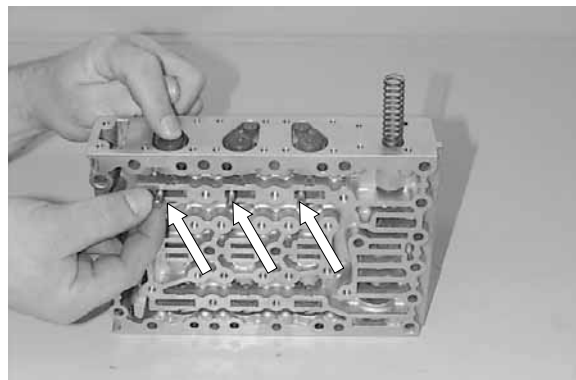

Figure 15

(4) Install two adjusting screws.

- ※ Line up flat gasket(Arrow) and housing cover(see Figure16).
Now, bring housing cover by means of adjusting screws uniformly against shoulder (Figure 17).

- ※ Speial tool
Adjusting screws 5870 204 036

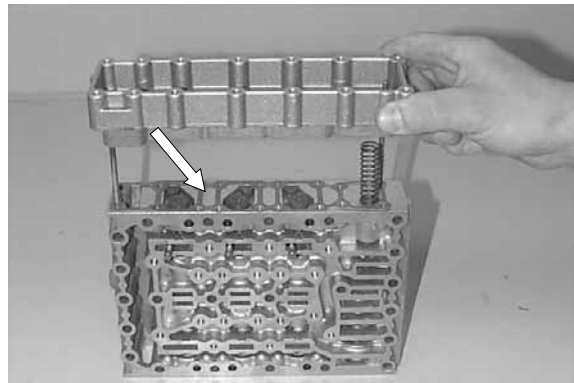

Figure 16

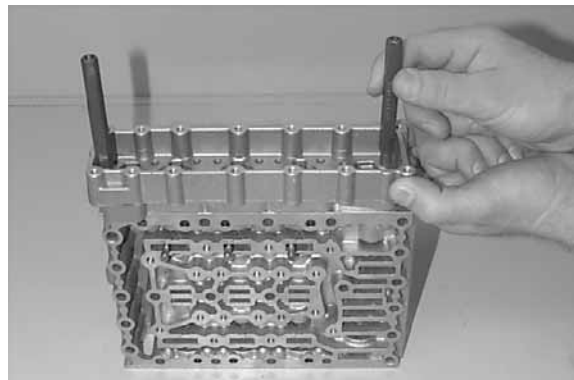

Figure 17

(5) Preload spool and remove the cylindrical pins(assembly aid) again.

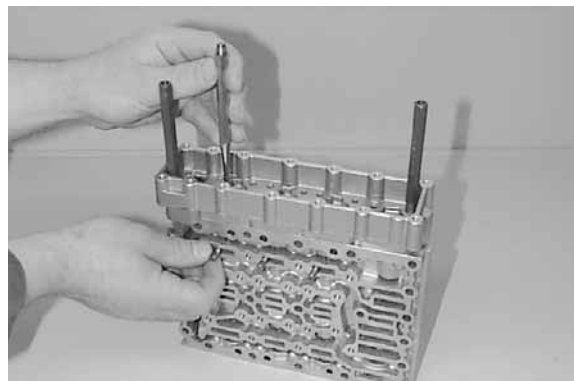

Figure 18

(6) Fasten housing cover by means of socket head screws.

- Torque limit : 0.56kgf · m (4.06lbf · ft)

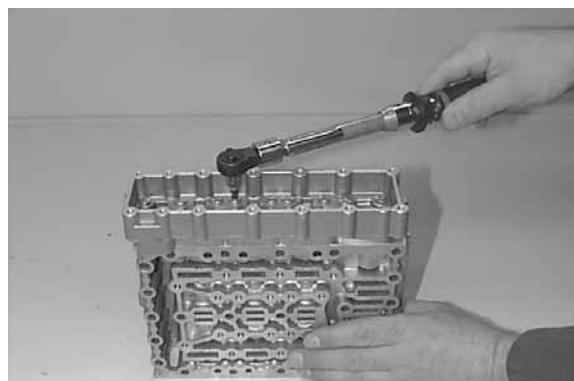

Figure 19

(7) Introduce pressure regulators and fix them by means of retaining plates and socket head screws.

※ Install retaining plates, with the claw showing downward. Pay attention to the radial installation position of the pressure regulators, see Figure.

• Torque limit : 0.56kgf · m (4.06lbf · ft)

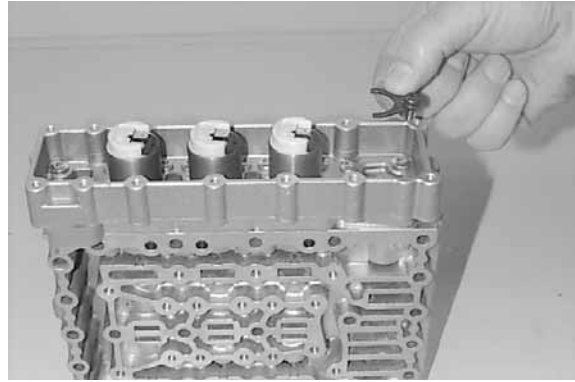

Figure 20

Pre-assembly opposite side

(8) The Figure on the right shows the following components:

1 Main pressure valve(1x spool and compression spring)

2 Follow-on slide(3x spool and compression spring)

3 Vibration damper(3x spool and compression spring)

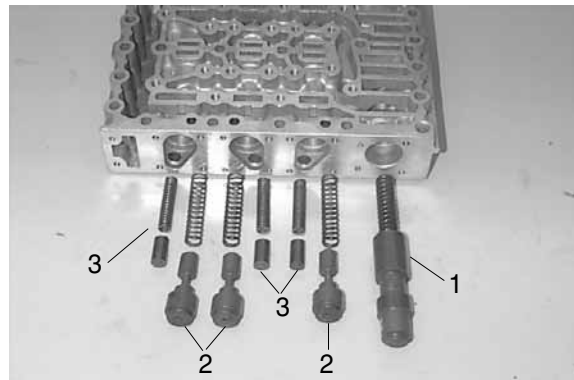

Figure 21

(9) Install components according to Figure 21.

Preload compression springs of the follow-on slides and fix the spools provisionally with cylindrical pins \varnothing 5mm(assembly aid), see Arrows.

Install two adjusting screws.

Line up flat gasket(Arrow 1) and housing cover and bring them uniformly against shoulder, using adjusting screws.

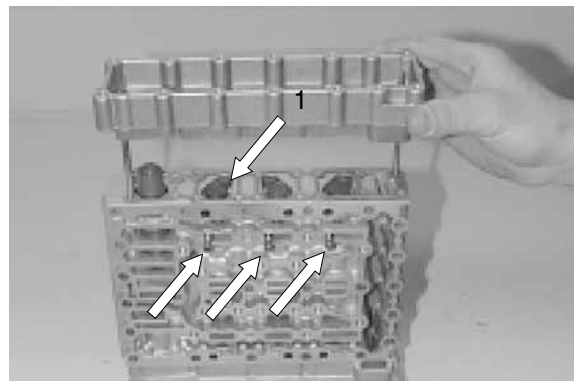

Figure 22

※ Now, fasten housing cover by means of socket head screws.

• Torque limit : 0.56kgf · m (4.06lbf · ft)

Remove cylindrical pins (assembly aid) again.

※ Special tool

Adjusting screws 5870 204 036

(10) Introduce pressure regulators and fix them by means of retaining plates and socket head screws.

※ Install retaining plates, with the claw showing downward. Pay attention to the radial installation position of the pressure regulators, see Figure.

· Torque limit : 0.56kgf · m(4.06lbf · ft)

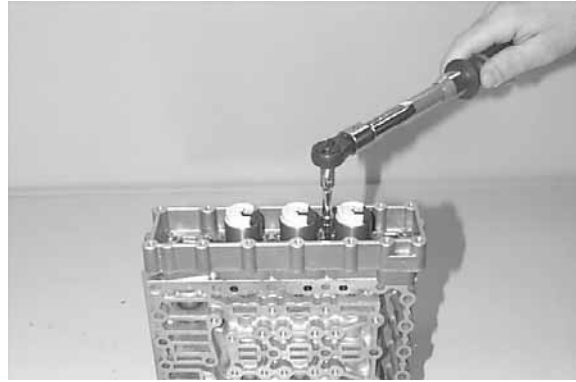

Figure 23

(11) Introduce cable harness and connect pressure regulators(6EA).

※ Pay attention to the installation position of the cable harness, see also markings (Figure 3).

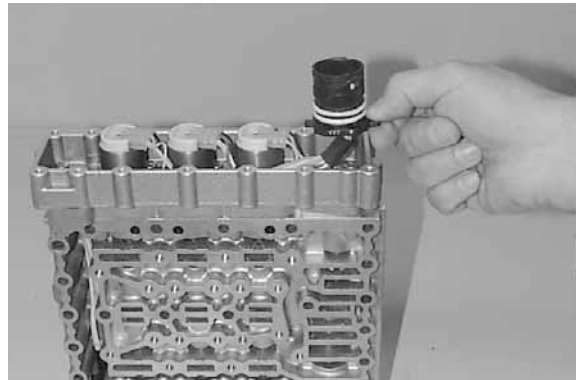

Figure 24

(12) Mount flat gasket(Arrow).

Introduce femal connector, with the groove facing the guide nose of the cover, until contact is obtained.

Fasten cover with socket head screws.

· Torque limit : 0.56kgf · m (4.06lbf · ft)

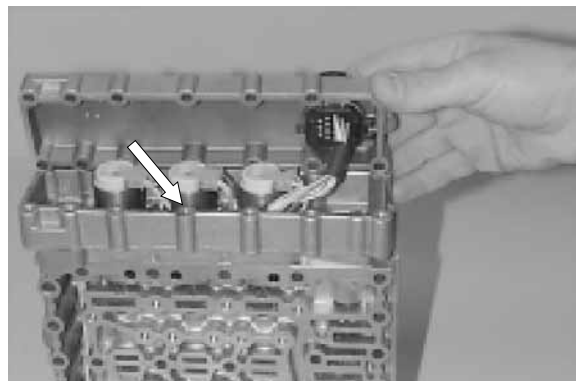

Figure 25

(13) Locate the femal connector by means of retaining clip.

Install opposite cover.

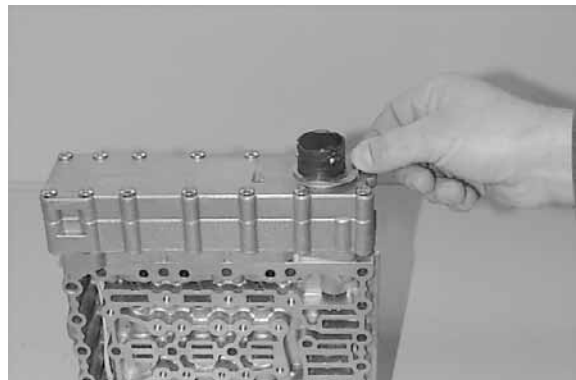

Figure 26

(14) Install two adjusting screws and mount gasket I.

※ Pay attention to the different gaskets, see Figure 27 and 30.

※ Special tool

Adjusting screws M6 5870 204 063

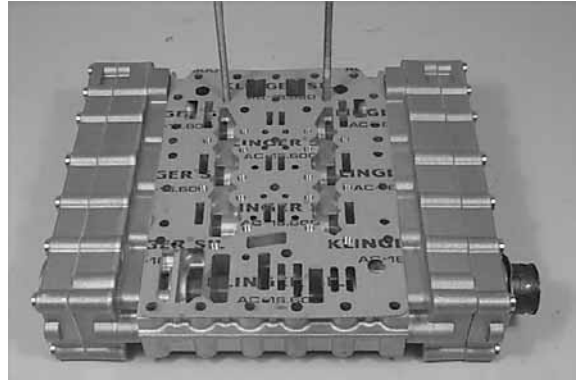

Figure 27

Intermediate plate-Version with strainers :

(15) Insert strainers(6EA) flush-mounted into the bores of the intermediate plate, see Arrows.

※ Pay attention to the installation position-strainers are showing upward (facing the duct plate).

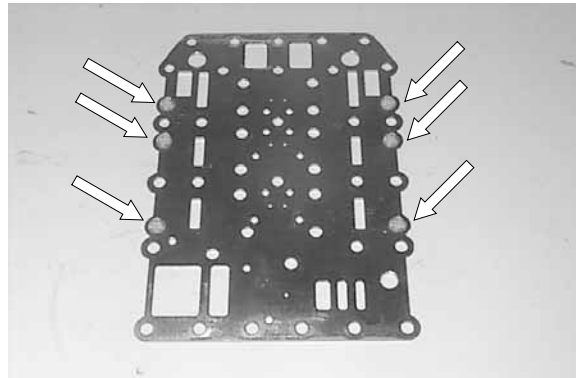

Figure 28

(16) Mount intermediate plate, with the strainers showing upward.

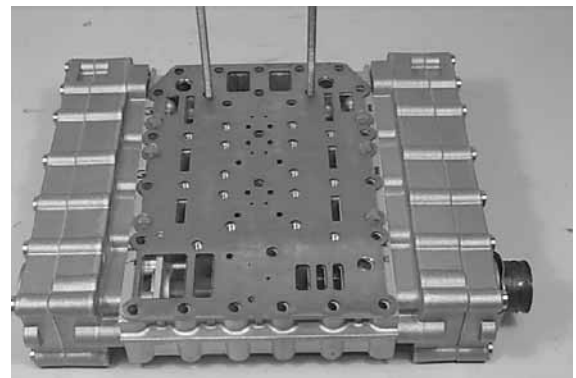

Figure 29

(17) Mount gasket II.

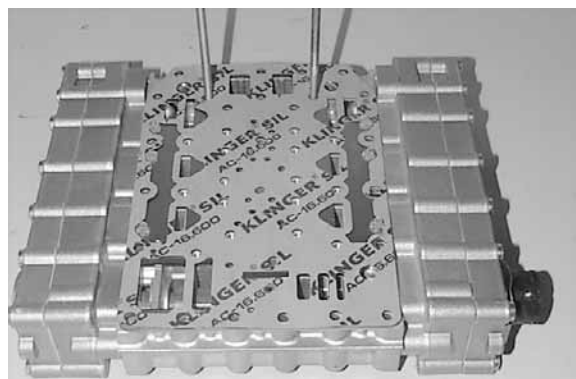

Figure 30

(18) Mount duct plate(Arrow) and fasten it uniformly by means of socket head screws.

· Torque limit : 0.97kgf · m (7.0lbf · ft)

※ Special tool

Box spanner TX-27 5873 042 002

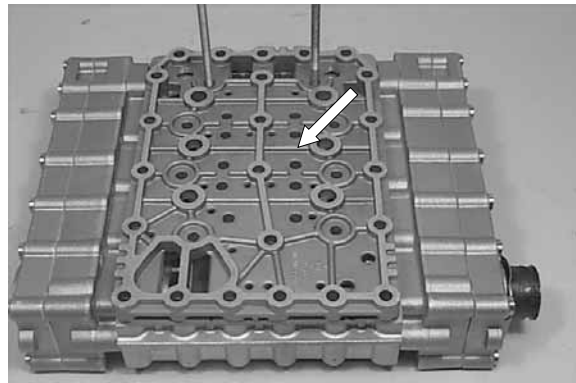

Figure 31

(19) Equip screw plugs(8EA) with new O-rings and install them.

· Torque limit : 0.61kgf · m (4.43lbf · ft)

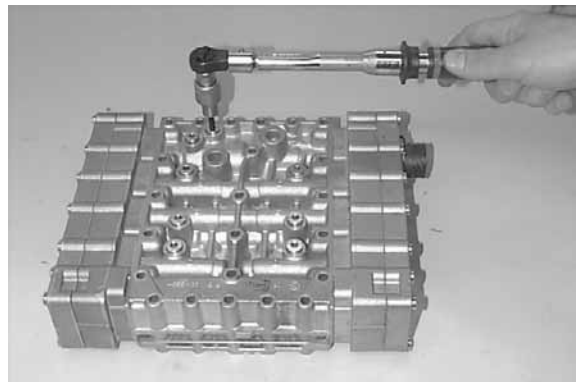

Figure 32

Attach Hydraulic control unit (Figure 33~40)

(20) Screw orifice into the housing bore(Arrow) and secure it by means of center punch.

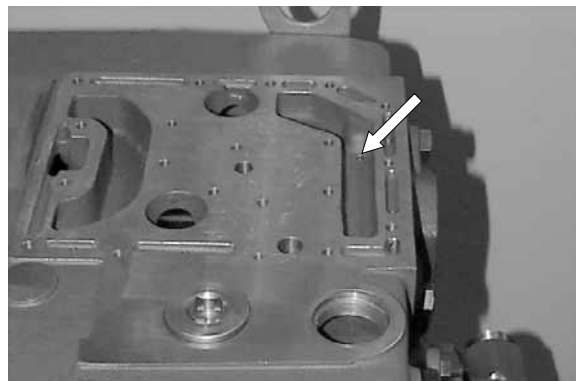

Figure 33

(21) Install connecting fittings 1~6.

Install screw plugs 7.

· Torque limit Screw plugs (M10x1):
0.61kgf · m (4.43lbf · ft)

※ Install always new O-rings.

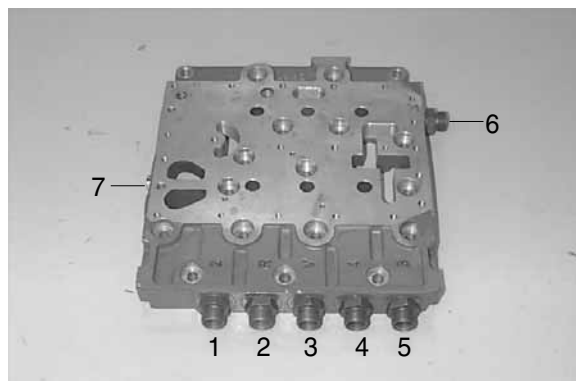

Figure 34

(22) Install two adjusting screws(M8) and mount housing gasket.

※ At the following steps(Figure 35~39), pay attention to the installation positions of the different gaskets.

※ Special tool

Adjusting screws M8 5870 204 011

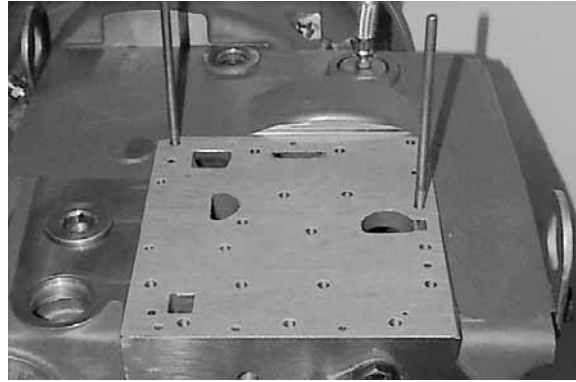

Figure 35

(23) Mount intermediate plate.

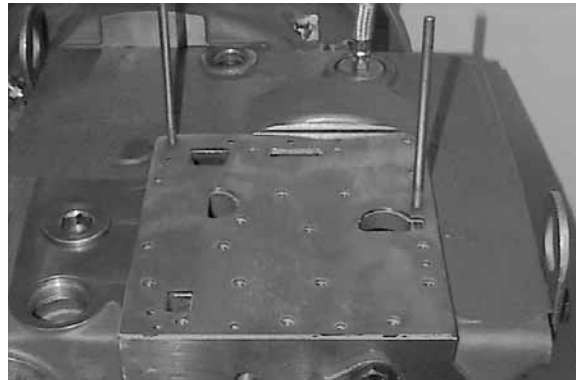

Figure 36

(24) Mount 2nd gasket.

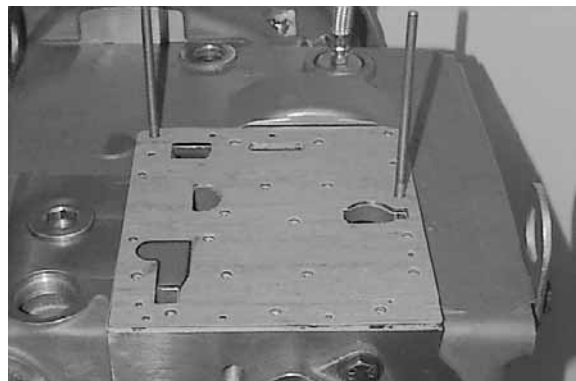

Figure 37

(25) Mount plate and fasten it uniformly by means of socket head screws.

· Torque limit(M8/10.9) :

2.35kgf · m (17.0lbf · ft)

※ Special tool

Box spanner TX-40 5873 042 004

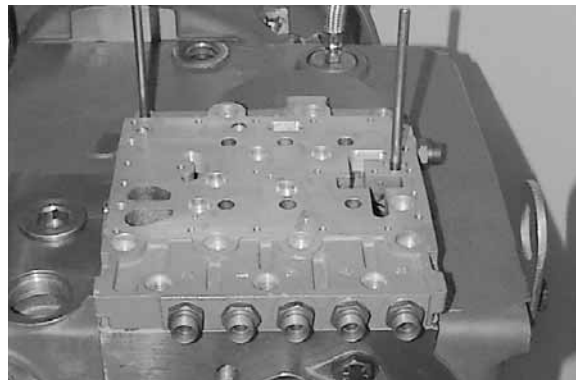

Figure 38

(26) Install 2 adjusting screws(M6).

Mount gasket(Arrow).

※ Special tool

Adjusting screws M6 5870 204 063

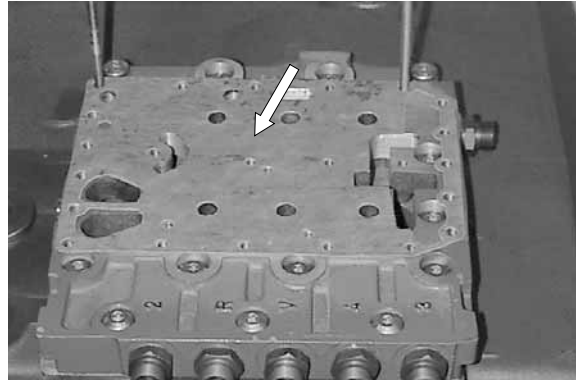

Figure 39

(27) Fasten complete valve block uniformly with socket head screws(2 pieces M6×105 and 21 pieces M6×80mm).

※ Pay attention to the position of the two socket head screws (M6×105), see Arrows.

• Torque limit : 0.97kgf · m (7.0lbf · ft)

※ Special tool

Box spanner TX-27 5873 042 002

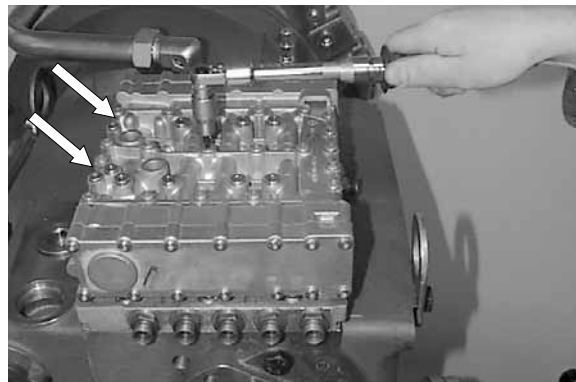

Figure 40

2. RETARDER

1) DISASSEMBLY

(1) Fasten the complete transmission on the assembly car.

※ Special tool

Assembly car 5870 350 000

Clamping bracket 5870 350 071

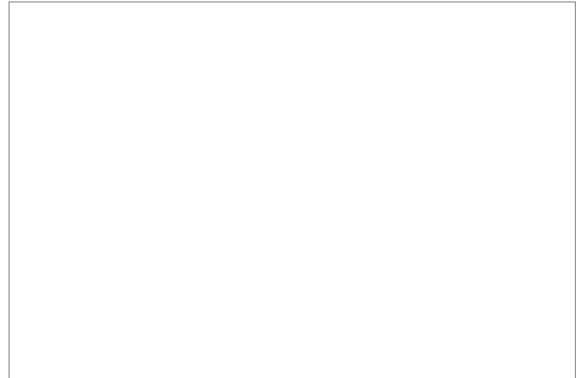

(2) Tilt gearbox housing 90° .

Remove lock plate.

Loosen hexagon head screws and pull off input flange.

※ If only operations on the transmission are necessary, the complete retarder can be separated, along with the converter, from the converter connecting housing by loosening the screw connection (Figure 56).



Figure 53

(3) Loosen screw plug.

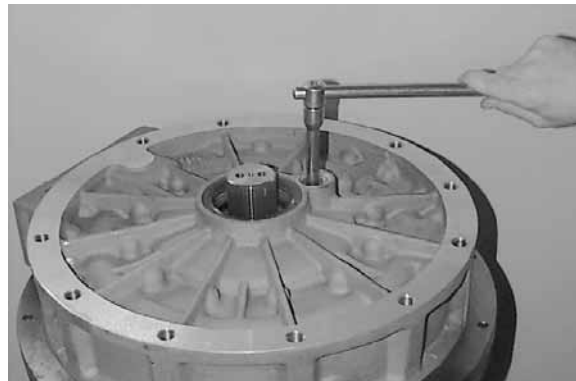

Figure 54

- (4) Loosen the first hexagon head screw and remove it by means of magnetic rod. Demount the remaining hexagon head screws accordingly.

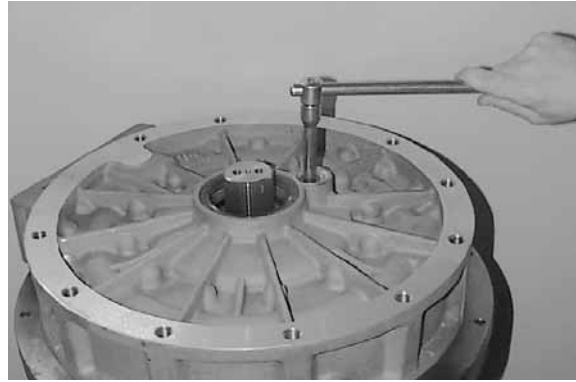

Figure 55

- (5) Loosen screw connection.

- ※ Mark the radial installation position of the retarder to the converter connecting housing.



Figure 56

- (6) Separate the complete retarder from the converter connecting housing, using lifting device.

- ※ Special tool
Set of eye bolts 5870 204 002



Figure 57

- (7) Loosen socket head screws, separate spacer ring from stator housing.



Figure 58

- (8) Loosen socket head screws and separate cover from stator housing.

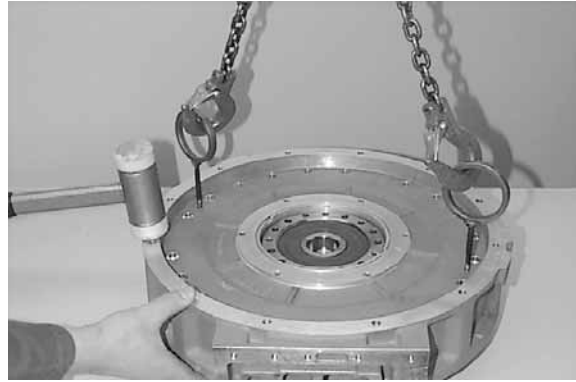

Figure 59

- (9) Drive flange shaft out.
- ※ Pay attention to the released components.
 - ※ Special tool
Plastic mallet 5870 280 004

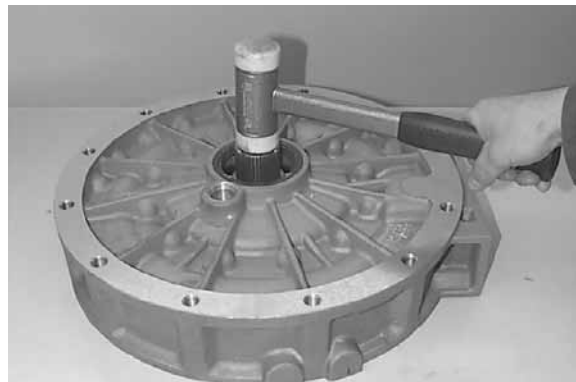

Figure 60

- (10) Separate rectangular ring from rotor.

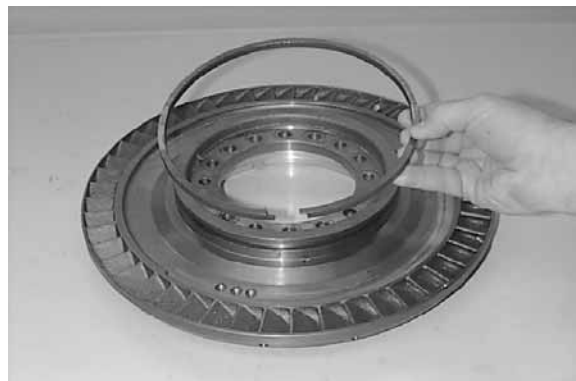

Figure 61

- (11) Remove the rectangular ring on the opposite side. If necessary, separate the ring (Arrow) from the rotor.



Figure 62

(12) Loosen hexagon head screws and remove thrust ring.

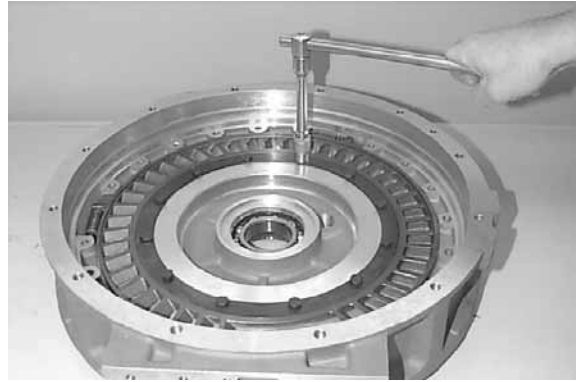

Figure 63

(13) Remove stator ring.

※ Pay attention to the released components.

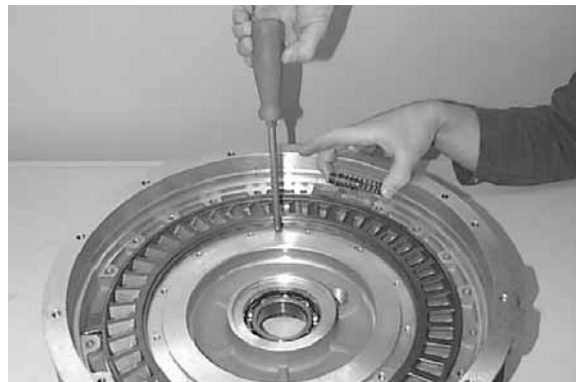

Figure 64

(14) Pry shaft seal out of the bore.

※ Special tool

Pry bar

5870 345 036



Figure 65

(15) Drive ball bearing out.



Figure 66

2) ASSEMBLY

- (1) Insert ball bearing until contact is obtained.

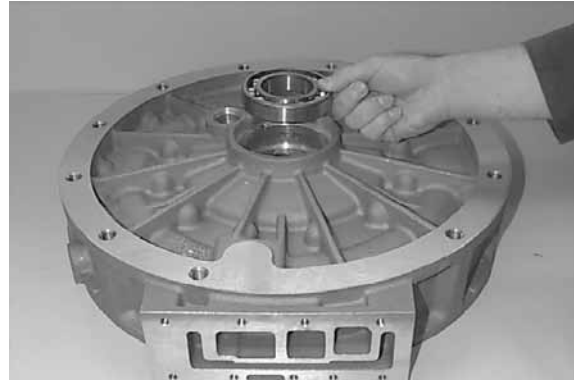

Figure 71

- (2) Insert stator ring.

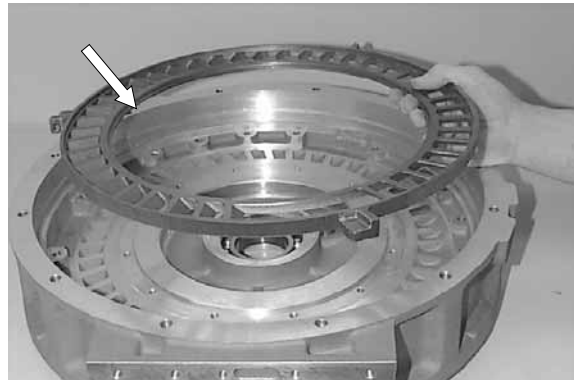

Figure 72

- (3) Fasten thrust ring by means of hexagon head screws.

- Torque limit (M8/8.8): 2.35kgf · m
(17.0lbf · ft)

- ※ Pay attention to the installation position—shoulder (Arrow) is showing upward. Secure hexagon head screws with Loctite (Type No. 243).

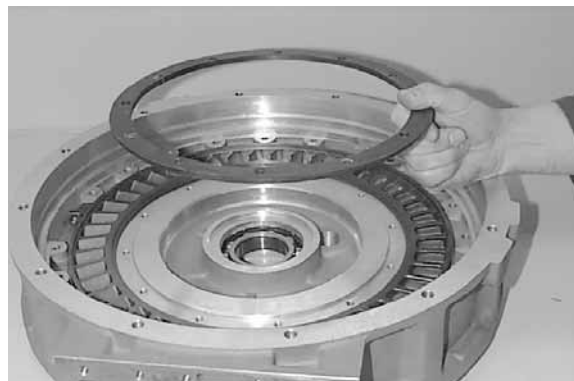

Figure 73

- (4) Preassemble dampers (3 pieces) according to Figure 75 and Figure 76.

- ※ The installation dimension $B=1.6^{+0.5}$ mm results from the alternating stacking of the cup spring packs (8 packs with 6 cup springs each).

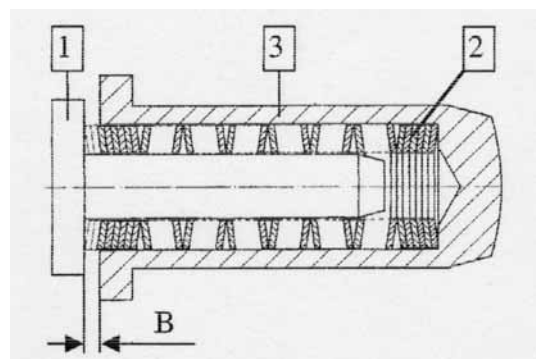

Figure 74

- 1 Guide pin
- 2 Cup spring packs(8 packs with 6 cup springs each)
- 3 Spring guide
- 4 Compression spring
- 5 Spring guide

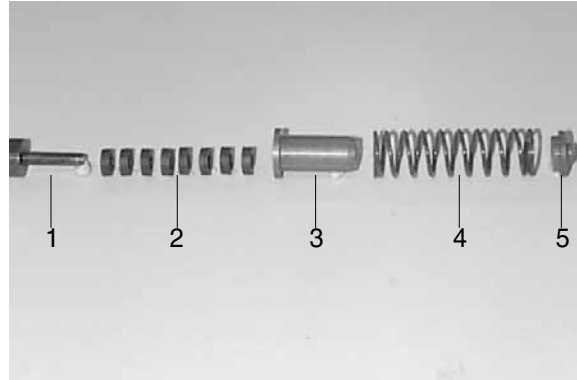

Figure 75

- (5) Install the preassembled dampers, see Arrows.

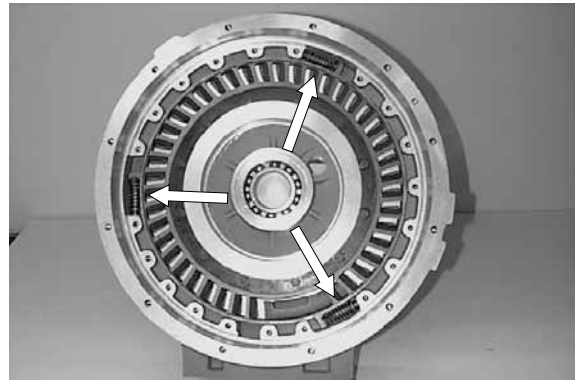

Figure 76

- (6) Introduce rectangular ring into the recess of the rotor(Figure 77) and preload it by means of cylindrical pins \varnothing 6mm (assembly aid), see Figure 78.

- ※ Install rectangular ring with the marking "Top" see Arrow, showing upward (to the prime mover).

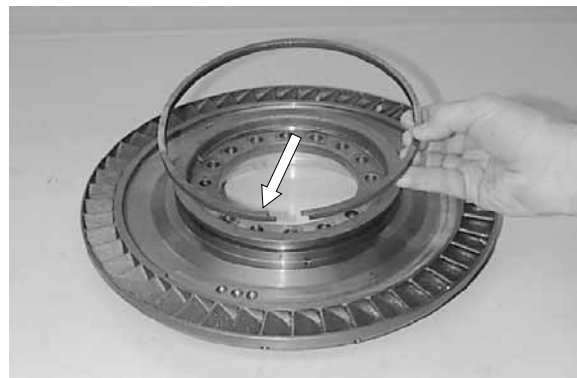

Figure 77

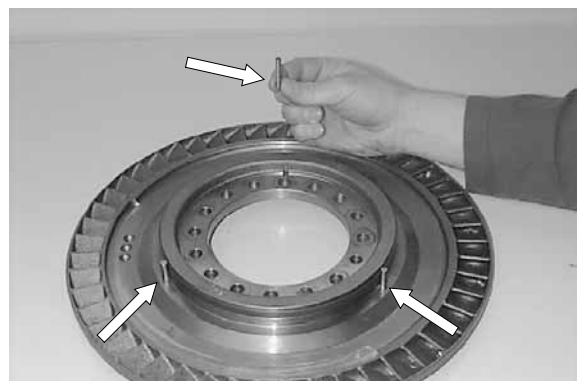

Figure 78

- (7) Grease rectangular ring.
Introduce rotor into the stator housing until contact is obtained and remove cylindrical pins again.

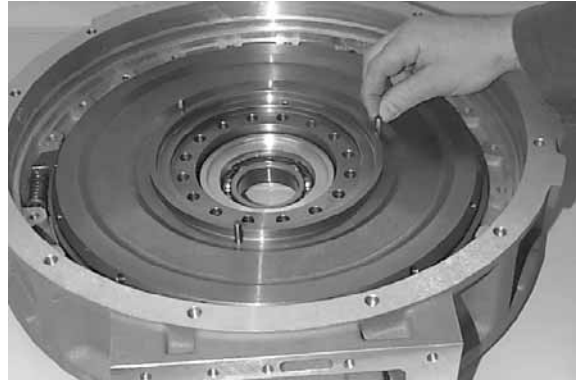

Figure 79

- (8) Grease rectangular ring.
※ Introduce rotor into the stator housing until contact is obtained and remove cylindrical pins again.

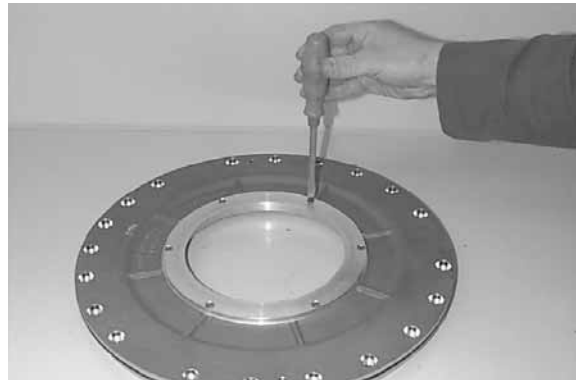

Figure 80

- (9) Insert ring into the cover, with the oil grooves showing downward.



Figure 81

- (10) Introduce rectangular ring.
※ Install rectangular ring with the marking "Top" see Arrow, showing upward (to the prime mover).



Figure 82

(11) Insert O-ring into the annular groove of the cover(Arrow) and grease it.

Install two adjusting screws and pull cover uniformly against shoulder, using 3 socket head screws.

- ※ Pay attention to the radial installation position.
- ※ Special tool
Adjusting screws M8 5870 204 011

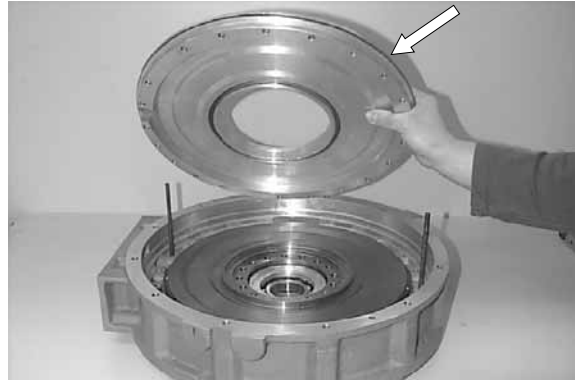

Figure 83

(12) Fasten cover finally by means of socket head screws (install flat washers).

- ※ Secure socket head screws with Loctite (Type No. 243).
- Torque limit(M8/10.9): 2.35kgf · m
(17.0lbf · ft)

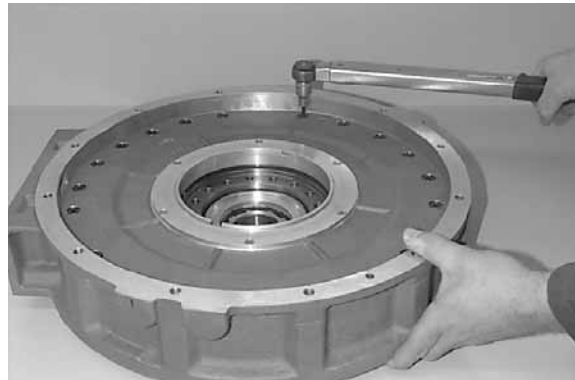

Figure 84

(13) Adjust Rotor dimension(distance between Rotor-Stator ring)=1.5~2.0mm (Figure 85~89):

Line up axial washer $s = 1.0\text{mm}$, axial roller cage and housing disk $s = 5.75\text{mm}$.



Figure 85

(14) Determine Dimension I from the housing disk to the mounting face.

· Dimension I e.g. 13.10mm

- ※ Special tool
Digital depth gauge 5870 200 072

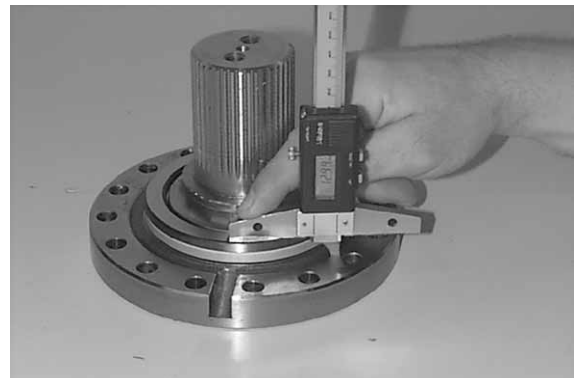

Figure 86

(15) Determine Dimension II from the mounting face(flange shaft) to the plane face/stator (contact face - axial bearing).

· Dimension II e.g. 14.00mm

EXAMPLE A

Dimension II 14.00 mm

Dimension I -13.10 mm

Difference 0.90 mm

Rotor play e.g. + 1.60 mm

Gives Shim e.g. s = 2.50 mm



Figure 87

(16) Insert housing disk s = 5.75 mm, axial roller cage and axial washer s = 1.0 mm.



Figure 88

(17) Mount shim s = 2.5 mm(see Example A)

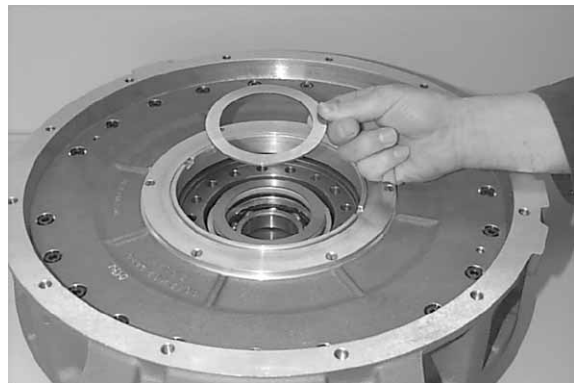

Figure 89

(18) Adjust Axial play - Ball bearing 0.10~0.20mm (Figure 90~93) :

Check exact contact of ball bearing(Arrow) once more and place preassembled stator housing over the plug gauge.

※ The ball bearing must be resting on the whole plane face(bearing inner and outer race).

※ Special tool

Plug gauge 5870 200 106



Figure 90

(19) Determine Dimension I from the shim to the bearing inner race.

Dimension I e.g. 25.20 mm

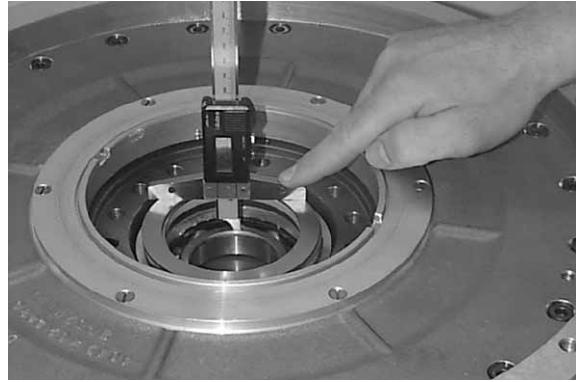

Figure 91

(20) Determine Dimension II from the locating face (ball bearing) to the contact face (shim).

Dimension II e.g. 25.05 mm

EXAMPLE B1 :

$$\begin{aligned} \text{Dimension II} - \text{Dimension I} &= \text{Dimension X} \\ 25.05 \text{ mm} - 25.20 \text{ mm} &= -0.15 \text{ mm} \end{aligned}$$

※ Minus dimension (X= -0.15 mm) corresponds with the pressure.

EXAMPLE B2 :

$$\begin{aligned} \text{Required play} - \text{Dimension X} &= \text{Shim} \\ 0.15 - (-0.15) &= 0.30 \text{ mm} \end{aligned}$$

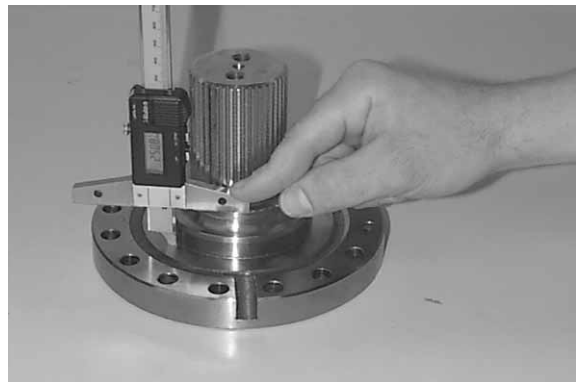

Figure 92

(21) Mount shim s = 0.3 mm (see **Example B2**) with grease.



Figure 93

(22) Heat bearing inner race.

※ Special tool

Hot-air blower 230V 5870 221 500

Hot-air blower 115V 5870 221 501



Figure 94

(23) Introduce flange shaft until contact is obtained.

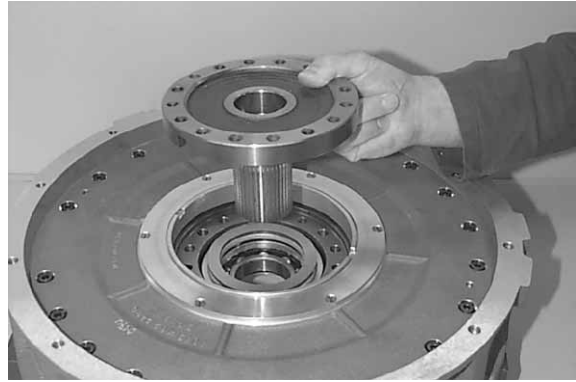

Figure 95

(24) Install shaft seal(Arrow), using driver.

- ※ At application of the prescribed driver, the exact installation position is obtained. Grease the sealing lip of the shaft seal. Wet outer diameter with spirit.

- ※ Special tool driver

5870 048 193

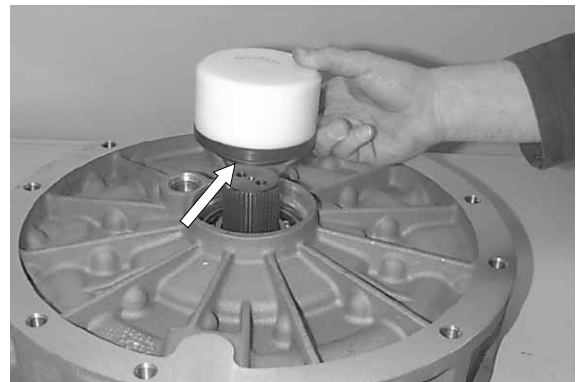

Figure 96

(25) Grease O-ring(Arrow) and insert it into the annular groove of the spacer ring.



Figure 97

(26) Fasten spacer ring by means of socket head screws.

- Torque limit(M10/8.8): 3.26kgf · m (23.6lbf · ft)

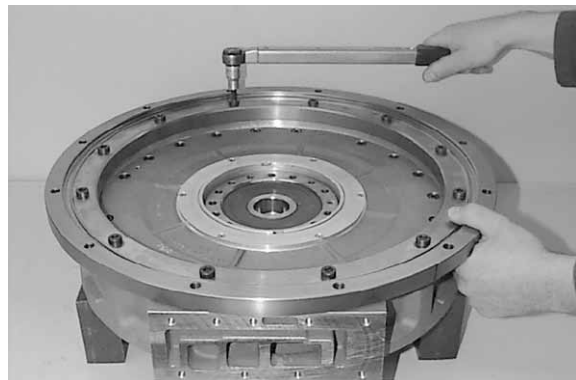

Figure 98

(27) Insert O-ring(Arrow) into the annular groove of the converter bell.



Figure 99

(28) Place the complete retarder on the converter bell until contact is obtained, using lifting device, and fasten it by means of hexagon head screws.

※ Pay attention to the radial installation position of the retarder.

- Torque limit(M12/8.8): 8.06kgf · m
(58.3lbf · ft)

※ Special tool

Set of eye bolts 5870 204 002



Figure 100

(29) Fasten rotor and flange shaft on the converter, using hexagon head screws.

※ Tighten hexagon head screws uniformly (180° displaced) as well as secure them with Loctite(Type No. 243).

- Torque limit(M10/8.8): 4.69kgf · m
(33.9lbf · ft)

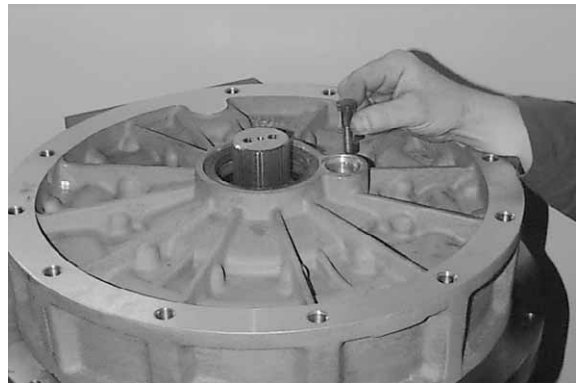

Figure 101

(30) Equip screw plug with new O-ring and install it.

- Torque limit (M30 × 1.5): 9.18kgf · m
(66.4lbf · ft)

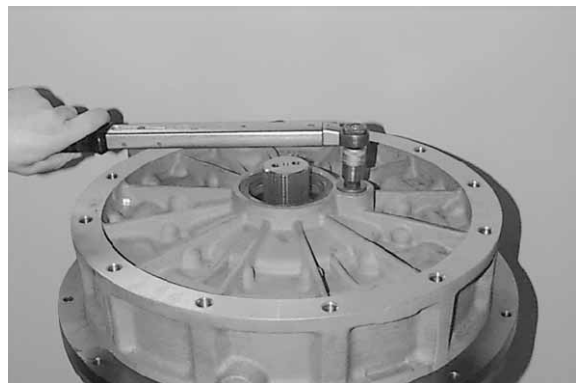

Figure 102

(31) Line up shim(s = 1.5 mm).



Figure 103

(32) Install dust plate(Arrow).

※ At application of the prescribed driver, the exact installation position is obtained.

※ Special tool

Driver 5870 506 127

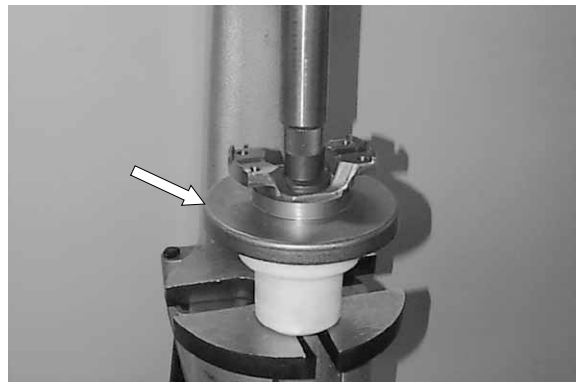

Figure 104

(33) Line up input flange and fasten it by means of disk and hexagon head screws.

※ Wet contact face of the disk with Loctite (Type No. 574).

• Torque limit (M10/8.8): 4.69kgf · m
(33.9lbf · ft)

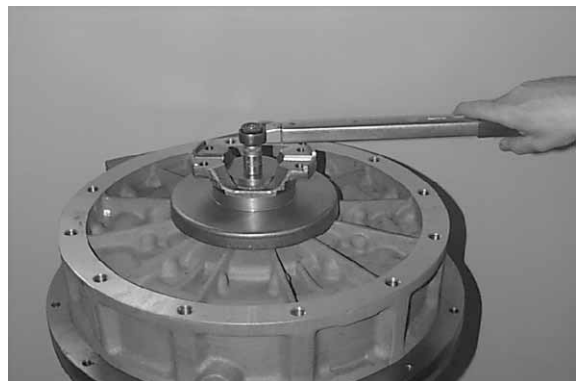

Figure 105

(34) Fix hexagon head screws with lock plate.

※ Special tool

Driver 5870 057 009

Handle 5870 260 002



Figure 106

3. TRANSMISSION

1) DISASSEMBLY

(1) Fasten the complete transmission on the assembly car.

※ Special tool

Assembly car 5870 350 000

Support 5870 350 071

Remove all oil lines.

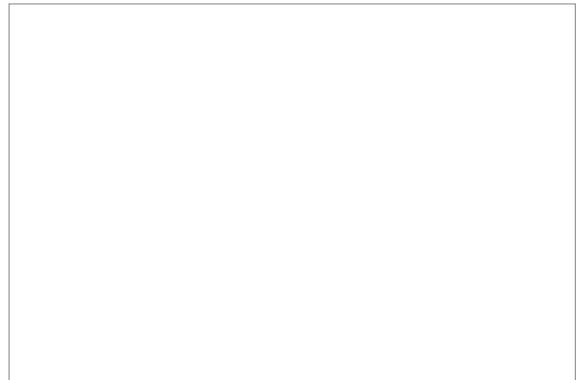

Figure 120

(2) Loosen hexagon head screws and lift complete retarder along with converter out of the converter bell, using lifting device.

※ Special tool

Lifting chain 5870 281 047

Set of eye bolts 5870 204 002

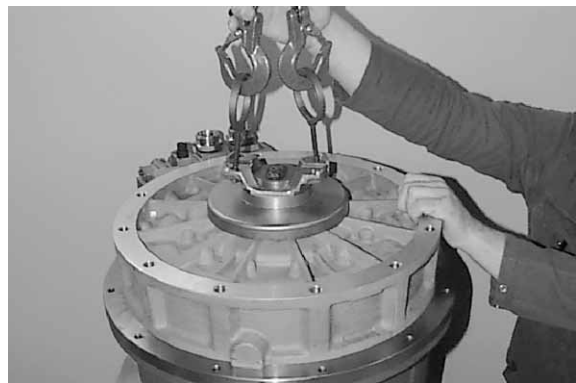

Figure 121

(3) Pull oil feed flange by means of special device out of the converter bell.

※ Special tool

Puller device 5870 000 089



Figure 123

(4) Remove converter safety valve (ball+spring, see Arrow).

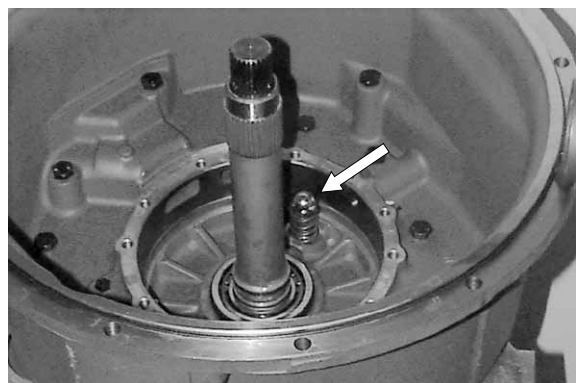

Figure 124

(5) Loosen screw connection(M8 and M12).
Separate converter bell from the
transmission, using lifting device.

※ Special tool

Lifting chain 5870 281 047

Set of eye bolts 5870 204 002



Figure 125

(6) Remove shim.



Figure 126

(7) Remove both rectangular rings(Arrow).



Figure 127

(8) Press input shaft out of the spur gear
bearing. Remove released bearing inner
race and spur gear.

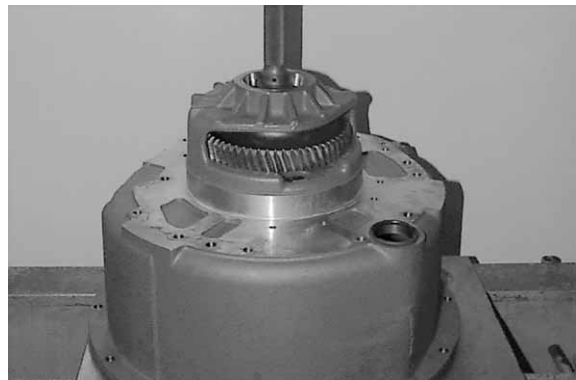

Figure 128

(9) Press bearing inner race from the input shaft.



Figure 129

(10) Remove converter pressure back-up valve.



Figure 130

(11) Pull the complete input shaft out of the gearbox housing, respective out of the pump.



Figure 131

(12) Squeeze rectangular ring out (Arrow).



Figure 132

(13) Separate spur gear from the shaft and squeeze circlip out (Arrow).

- ※ Special tool
Set of pliers 5870 900 016

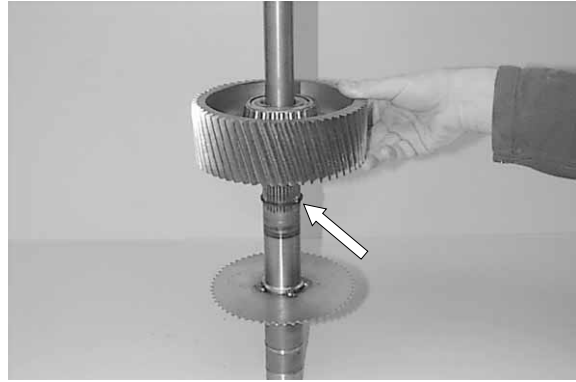

Figure 133

(14) Pull bearing inner race from spur gear.

- ※ Special tool
Grab sleeve 5873 001 020
Basic tool 5873 001 000



Figure 134

(15) Pull bearing inner race from spur gear.

- ※ Special tool
Grab sleeve 5873 001 020
Basic tool 5873 001 000



Figure 135

(16) Pull bearing inner race and driver from the shaft.

- ※ Support puller on the end face-input shaft.
Pay attention to the released shims.
- ※ Special tool
3-Leg puller 5870 971 002



Figure 136

(17) Separate bearing inner race from driver.

※ Pay attention to released washers.

If necessary, squeeze circlips(3EA) out.

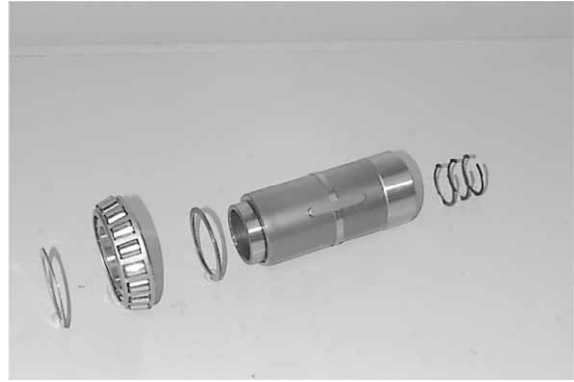

Figure 137

Transmission pump

(1) Tilt gearbox housing 180°.

Loosen hexagon head screws and separate both pump flanges from the housing.

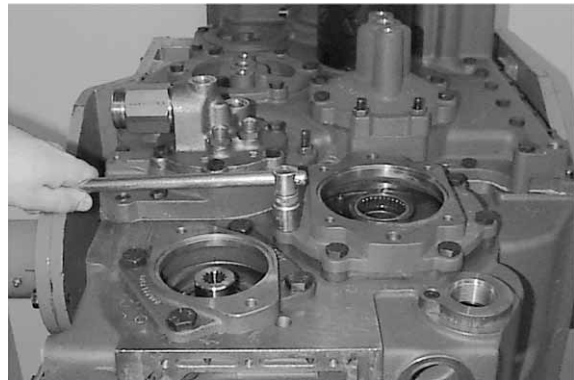

Figure 138

(2) Loosen socket head screws(M8) and position puller device. Pull transmission pump out of the housing bore.

※ Tapping onto the housing face will help at the extraction procedure.

※ Special tool

Puller device 5870 000 089

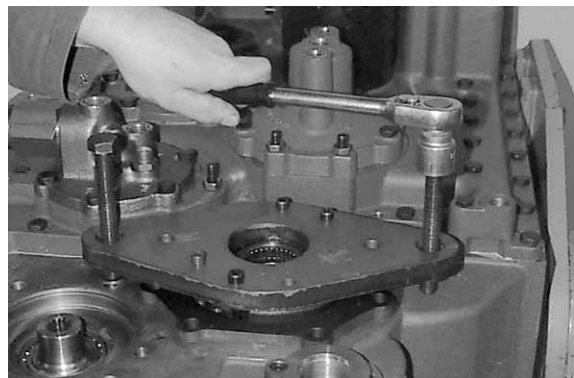

Figure 139

(3) Pull bearing outer race out of the bore and remove spacer.

※ Special tool

Internal puller 5870 300 017

Counter support 5870 300 009



Figure 140

(4) Loosen socket head screws, demount pump cover and remove rotor set.

※ If traces of wear should be encountered in the pump housing or the housing cover, the complete pump has to be renewed.

Now, introduce the rotor set, with the chamfer on the tooth crest showing downward, and install housing cover again.

- Torque limit(M8/8.8): 2.35kgf · m (17.0lbf · ft)
- Torque limit(M6/8.8): 0.97kgf · m (7.0lbf · ft)

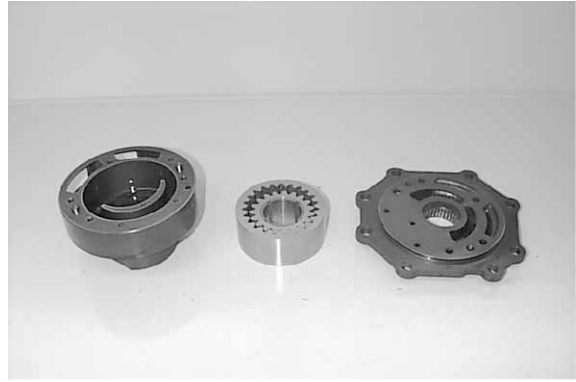

Figure 141

Emergency steering pump

(1) Loosen hexagon head screws and pry the emergency steering pump out of the housing.

※ Special tool

Crow bar

5870 345 071



Figure 142

(2) Remove lock plate.

Loosen hexagon head screws and remove disk. Pull output flange from the shaft.



Figure 143

(3) Tilt gearbox housing 180°.

Loosen hexagon head screws, demount cover and remove filter.

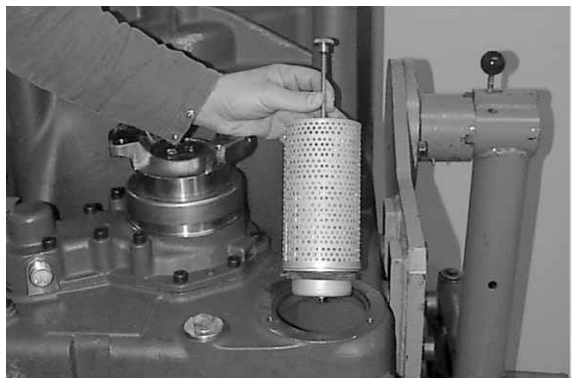

Figure 144

Axle disconnection device

- (1) Remove lock plate, loosen hexagon head screws and pull off output flange.



Figure 145

- (2) Loosen socket head screws and hexagon head screws.

- ※ Separate axle disconnection device from the housing, using pry bars.

During the separating procedure, drive the output shaft by tapping downward.

- ※ Special tool

Pry bar 5870 345 071

Plastic mallet 5870 280 004

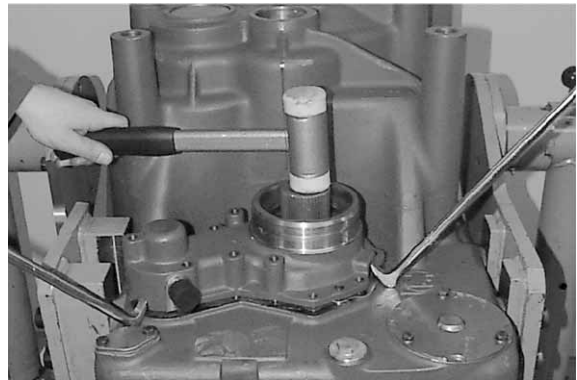

Figure 146

- (3) Disassemble switch and detent pin.

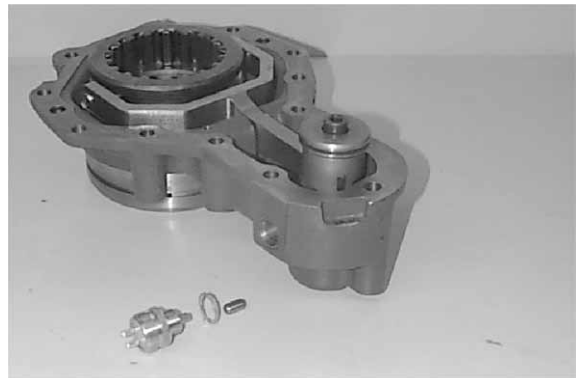

Figure 147

- (4) Disassemble switch and detent pin.



Figure 148

(5) Remove cover as well as circlip and drive pin out of the bore, using striker.

Remove the released components.

※ Special tool

Striker 5870 650 001



Figure 149

(6) Remove shaft seal.

Squeeze circlip out and remove spacer as well as shim.

Now, remove the ball bearing.



Figure 150

Counter shaft

- (1) Remove sealing cover and loosen hexagon head screws.



Figure 151

- (2) Tilt gearbox housing 90°.

Drive counter shaft axle by means of striker out of the housing bore, respective counter shaft bearing.

※ Special tool

Striker

5870 650 014

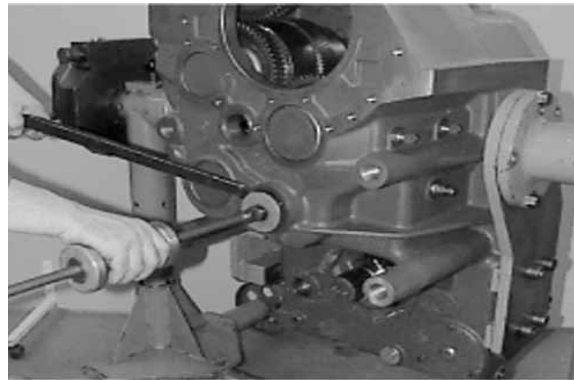

Figure 152

Disassemble Inductive transmitter (3EA)

6 = n-Turbine

39 = n-Central gear train

14 = n-Engine

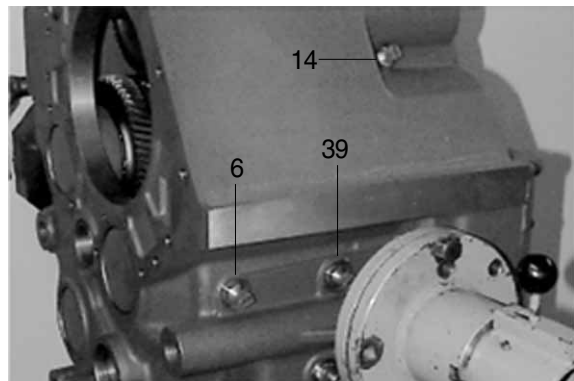

Figure 153

- (1) Tilt gearbox housing 90°.

Loosen hexagon head screws and pull bearing cover KV/K1 out of the housing bore.

Disassemble bearing cover KR/K2 and K4/K3 accordingly.

※ Mark installation position of the bearing covers.

※ Special tool

Counter support

5870 300 020

Threaded insert

5870 204 042

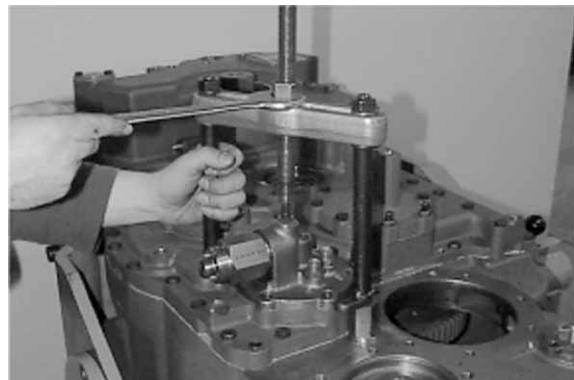

Figure 154

(2) Loosen screw connection and separate housing cover by means of back-off screws (Arrows) and lifting device from the gearbox housing.

※ During the separating procedure, drive the output shaft by tapping continuously downward.

※ Special tool

Back-off screws 5870 204 005

Lifting device 5870 281 055

Plastic mallet 5870 280 004

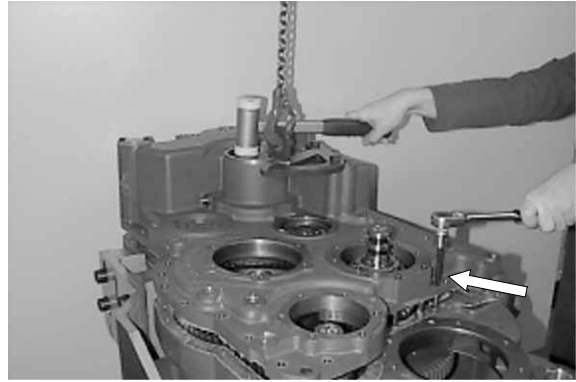

Figure 155

(3) Loosen hexagon head screws and remove cover plate.



Figure 156

Interaxle differential

(1) Lift differential by means of lifting device out of the gearbox housing.

※ Special tool

Lifting device 5870 281 047

Set of eye bolts 5870 204 002



Figure 157

(2) Remove plate and disassemble bearing inner race.

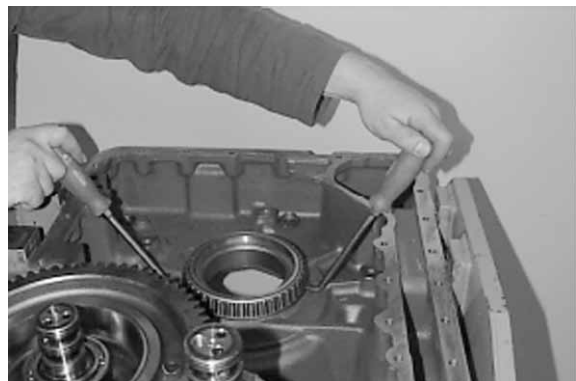

Figure 158

- (3) Remove plate and disassemble bearing inner race.



Figure 160

- (4) Remove bush.



Figure 161

- (5) Squeeze snap ring out and pull output shaft out of the planet carrier.



Figure 162

- (6) Squeeze snap ring out and pull output shaft out of the planet carrier.



Figure 163

(7) Pull bearing inner race from the internal gear.

※ Special tool

Quick-acting grip 5870 014 014

Basic tool 5873 004 001



Figure 164

(8) Squeeze snap ring out.



Figure 165

(9) Press internal gear and planet carrier out of the internal gear.

※ Figure 167 shows the released component.



Figure 166



Figure 167

(10) Drive roll pins(Arrows) carefully in until contact is obtained.

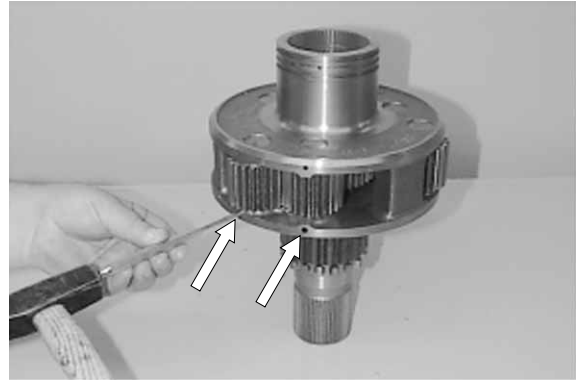

Figure 168

(11) Drive roll pins(Arrows) carefully in until contact is obtained.



Figure 169

(12) Press output shaft far enough downward until the sun gear can be removed, see also Figure 171.



Figure 170

(13) Squeeze snap ring out(Arrow) and separate output shaft from planet carrier.

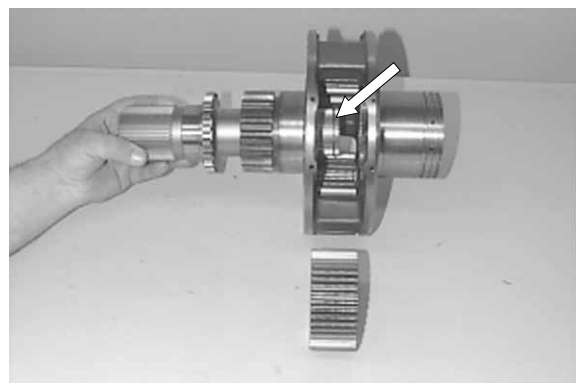

Figure 171

- (14) If necessary, pry baffle ring out of the planet carrier bore, squeeze snap ring out (Figure 172) and drive the needle bearing out (Figure 173).



Figure 172



Figure 173

Disassemble Multi-disk clutches

- (1) Disassemble clutch K4/K3, KR/K2 and KV/K1 by means of lifting device.

※ At the disassembly of the clutch K4/K3, lift clutch KR/K2 slightly and displace it in arrow direction, see Figure on the right.

※ Special tool

Set of eye bolts

5870 204 002



Figure 175

- (2) The Figure on the right shows the clutches in disassembled condition.



Figure 176

(3) Remove counter shaft gear.



Figure 177

Disassemble power take-off

(1) Squeeze circlip out and remove shims.

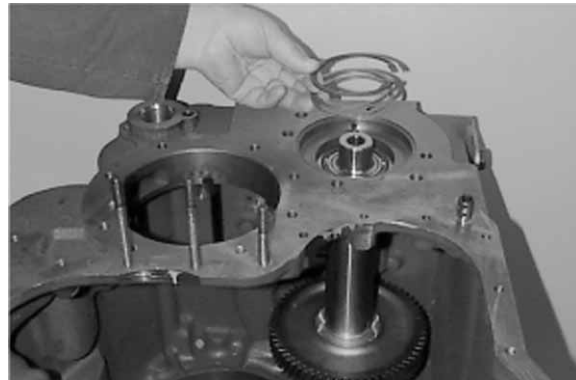

Figure 178

(2) Lift output shaft by means of pry bar until the bearing outer race is free.

※ Special tool

Pry bar

5870 345 036

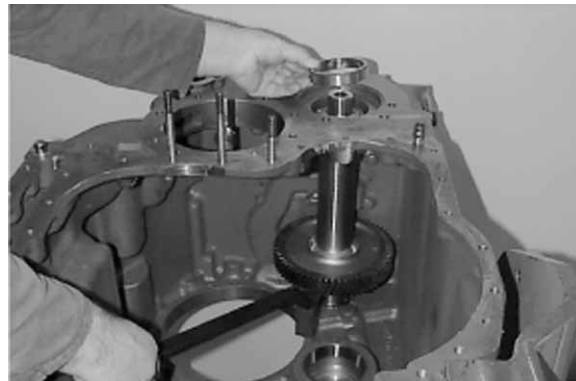

Figure 179

(3) Take output shaft out of the housing.



Figure 180

(4) Pull bearing outer race out of the housing bore.

- ※ Special tool
- Internal puller 5870 300 007
- Counter support 5870 300 003

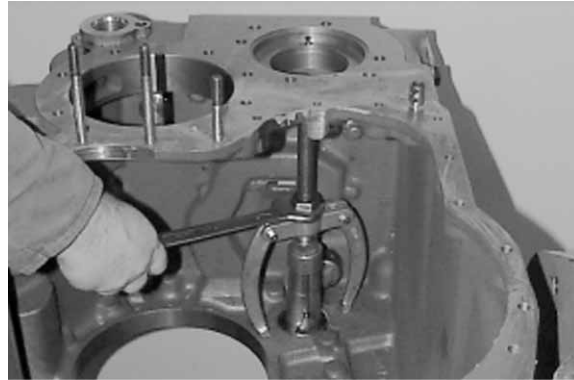

Figure 181

(5) Pull bearing inner race from the shaft (Figure 182).

Press opposite bearing inner race from the shaft.

- ※ The separation of shaft and gear is not possible (shrink fit).
- ※ Special tool
- Grab sleeve 5873 001 027
- Basic tool 5873 001 000



Figure 182

Dismantle Multi-disk clutch-K3/K4

(1) Fasten clutch by means of clamping ring on the assembly car.

- ※ Special tool
- Clamping ring 5870 654 022



Figure 185

(2) Pull roller bearing from plate carrier.

- ※ Special tool
- 3-Leg puller 5870 971 002



Figure 186

(3) Separate spur gear K3 from plate carrier.



Figure 187

(4) Pull bearing inner race from plate carrier.

※ Special tool

Quick-acting grip 5873 012 012

Basic tool 5873 002 001



Figure 188

(5) Squeeze snap ring out.

Disassemble end shim and plate pack K3.



Figure 189

(6) Tilt plate carrier 90°.

Loosen slotted nut.

※ Slotted nut is secured with loctite.

To prevent a damage of the thread, heat the slotted nut prior to loosen it (about 120°C).

※ Special tool

Hook spanner 5870 401 118

Hook spanner 5870 401 115

Hot-air blower 230V 5870 221 500

Hot-air blower 115V 5870 221 501

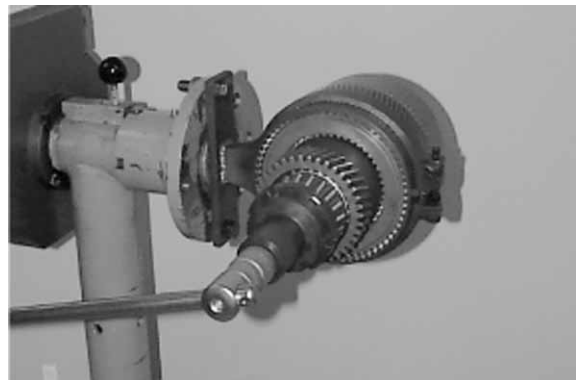

Figure 190

(7) Tilt plate carrier 90° .
Pull off the tapered roller bearing.

- ※ Speial tool
- Grab sleeve 5873 001 037
- Grab sleeve 5870 001 000

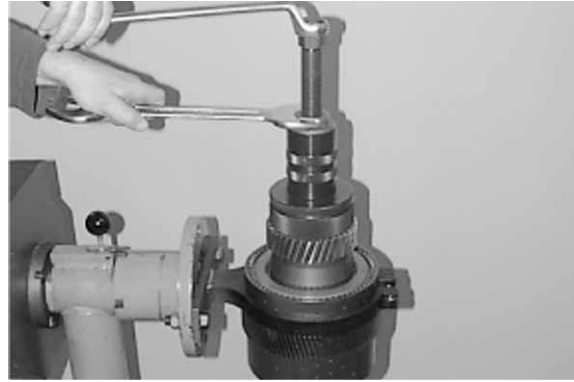

Figure 191

(8) Pull spur gear K4 from plate carrier.

- ※ Special tool
- 3-Leg puller 5870 971 003



Figure 192

(9) Remove adjusting ring.



Figure 193

(10) Pull off tapered roller bearing.

- ※ Special tool
- 3-Leg puller 5870 971 002



Figure 194

(11) Squeeze snap ring out.

Disassemble end shim and plate pack K4.



Figure 195

(12) Preload compression spring by means of Special device. Squeeze snap ring out and remove the released components.

Disassemble opposite components (K3-side) accordingly.

※ Special tool

Pressure piece 5870 345 072



Figure 196

(13) Separate both pistons by means of compressed air from the plate carrier.

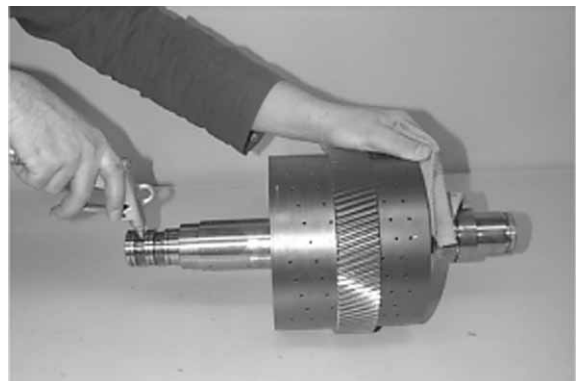

Figure 197

Dismantle Multi-disk clutch KR/K2

(1) Fasten clutch by means of clamping ring (Arrow) on the assembly car.

※ Special tool

Clamping ring 5870 654 022



Figure 198

- (2) Tilt plate carrier 90° .
Loosen slotted nut.

※ Slotted nut is secured with loctite.
To prevent a damage of the thread, heat the slotted nut prior to loosen it (about 120°C).

※ Special tool
Hook spanner 5870 401 099

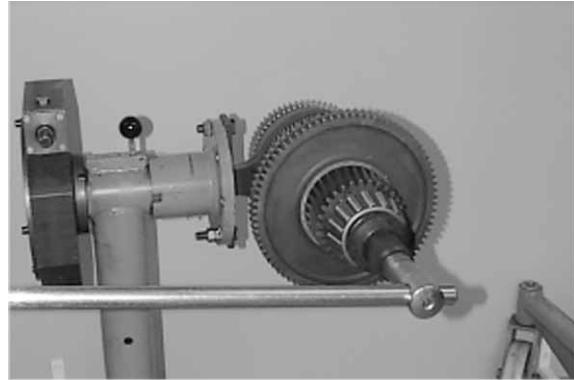

Figure 199

- (3) Pull tapered roller bearing from plate carrier.

※ Special tool
Grab sleeve 5873 012 018
Basic tool 5873 002 001



Figure 200

- (4) Press spur gear K2 from the plate carrier.

※ Pay attention to the released plate carrier.



Figure 201

- (5) Fix plate carrier by means of clamping ring.
Remove shim.

※ Special tool
Clamping ring 5870 654 022



Figure 202

(6) Pull tapered roller bearing from plate carrier.

※ Special tool

Grab sleeve 5873 012 019

Basic tool 5873 002 001



Figure 203

(7) Squeeze snap ring out.

Disassemble end shim and plate pack K2.

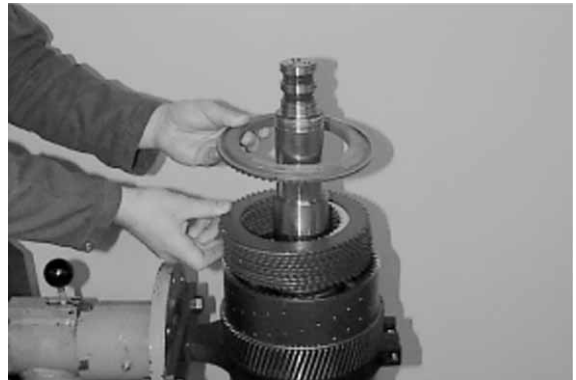

Figure 204

(8) Tilt plate carrier 90°.

Loosen slotted nut.

※ Slotted nut is secured with loctite.

To prevent a damage of the thread, heat the slotted nut prior to loosen it (about 120° C).

※ Special tool

Hook spanner 5870 401 099

Hot-air blower 230V 5870 221 500

Hot-air blower 115V 5870 221 501



Figure 205

(9) Pull tapered roller bearing from plate carrier.

※ Special tool

Grab sleeve 5873 002 044

Basic tool 5873 002 001



Figure 206

(10) Pull tapered roller bearing from plate carrier.

- ※ Special tool
- Grab sleeve 5873 002 044
- Basic tool 5873 002 001



Figure 207

(11) Remove adjusting rings.



Figure 208

(12) Squeeze snap ring out.
Disassemble end shim and plate pack KR.



Figure 209

(13) Pull tapered roller bearing from plate carrier.

- ※ Special tool
 - Grab sleeve 5873 002 023
 - Basic tool 5873 002 001
- Disassemble both pistons, as described at Figure 196 and 197.



Figure 210

Dismantle Multi-disk clutch KV/K1

Fasten clutch by means of clamping ring on the assembly car. Loosen slotted nut (Figure 211).

- ※ Slotted nut is secured with Loctite.
To prevent a damage of the thread, heat the slotted nut prior to loosen it (about 120°C).
- ※ Special tool
 - Clamping ring 5870 654 022
 - Hook spanner 5870 401 118
 - Hook spanner 5870 401 099

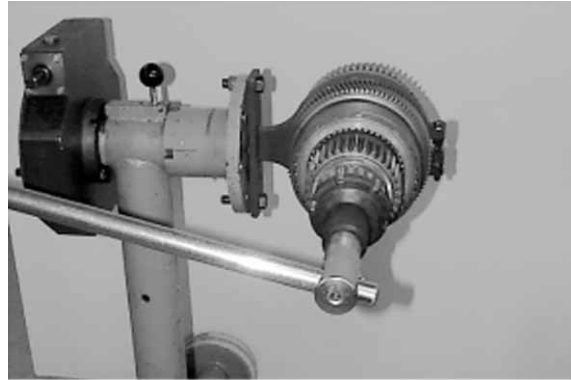

Figure 211

(1) Pull tapered roller bearing from plate carrier.

- ※ Special tool
 - Grab sleeve 5873 001 023
 - Basic tool 5873 001 000



Figure 212

(2) Remove disk



Figure 213

(3) Pull spur gear K1 from plate carrier.

- ※ Special tool
 - 3-Leg puller 5870 971 003



Figure 214

(4) The Figure on the right shows the spur gear bearing K1.
The bearing(1) is only as sub-assembly available.

※ If the disassembly of the plate pack-side ball bearing(Arrow, respective Figure 217 and 218) is necessary, the complete bearing (1) must be renewed.

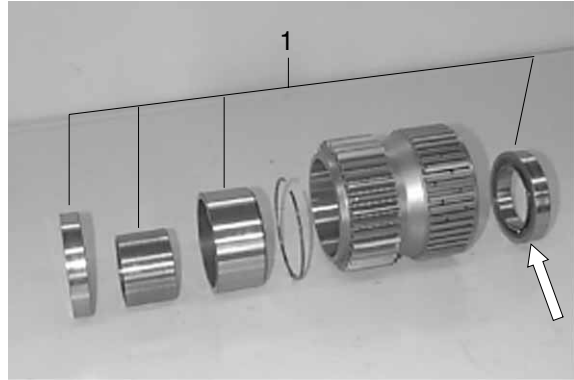

Figure 215

(5) Remove bush.



Figure 216

(6) Pull ball bearing from plate carrier(Figure 217 and 218).

※ Pay attention to the released balls.

※ Special tool

Pry bar

5870 345 036



Figure 217



Figure 218

- (7) Squeeze snap ring out.
Disassemble end shim and plate pack K1.



Figure 219

- (8) Tilt plate carrier 90° .
Loosen slotted nut.
- ※ Slotted nut is secured with Loctite.
To prevent a damage of the thread, heat the slotted nut prior to loosen it(about 120° C).

- ※ Special tool

Hook spanner	5870 401 118
Hook spanner	5870 401 115
Hot-air blower 230V	5870 221 500
Hot-air blower 115V	5870 221 501



Figure 220

- (9) Pull tapered roller bearing from plate carrier.

- ※ Special tool

Grab sleeve	5873 001 034
Basic tool	5873 001 000



Figure 221

- (10) Pull spur gear KV from plate carrier.

- ※ Special tool

3-Leg puller	5870 971 003
--------------	--------------



Figure 222

(11) Remove shim and ring.



Figure 223

(12) Pull tapered roller bearing from plate carrier (Figure 224).
Squeeze snap ring out.
Disassemble end shim and plate pack KV.
Disassemble both pistons (as described at Figure 196 and 197).

※ Special tool
Grab sleeve 5873 001 020
Basic tool 5873 001 000



Figure 224

2) ASSEMBLY

(1) Install studs (Arrows).

※ Wet thread with Loctite (Type No. 243).

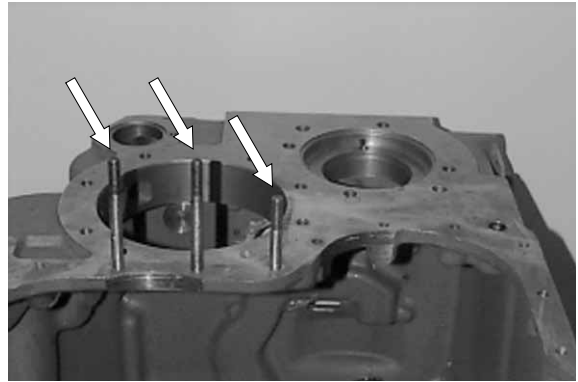

Figure 230

(2) Line up O-ring (Arrow).

Insert besh into the housing bore until contact is obtained and fasten it.

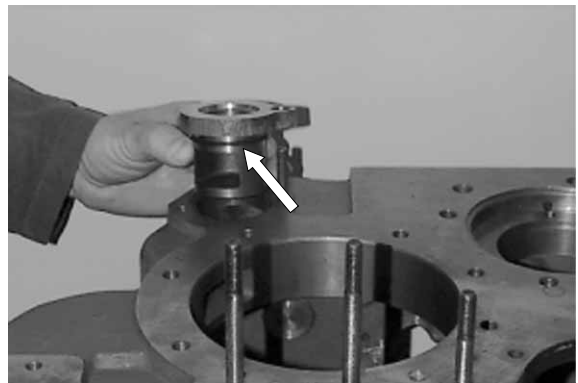

Figure 231

Power take-off

(1) Supercool the shaft (about -80°C), heat gear ($+120^{\circ}\text{C}$) and line it up, respectively press it against shoulder.

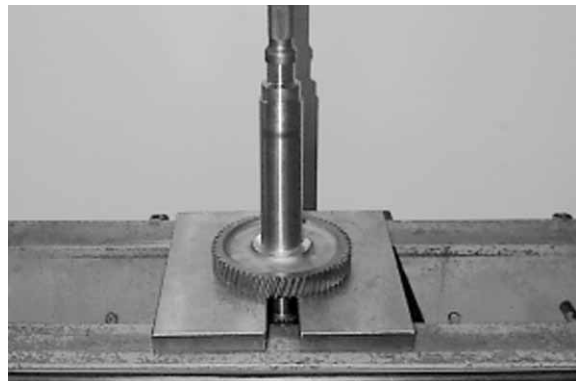

Figure 232

(2) Press bearing inner race against shoulder. Press opposite bearing inner race against shoulder.



Figure 233

- (3) Insert bearing outer race(Arrow) into the housing bore until contact is obtained.

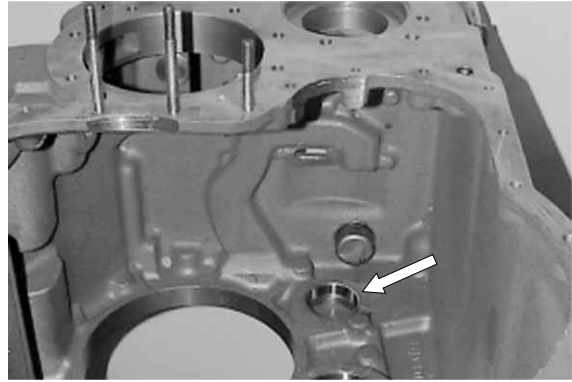

Figure 234

- (4) Position preassembled pto-shaft in the housing, and insert bearing outer race until contact is obtained.

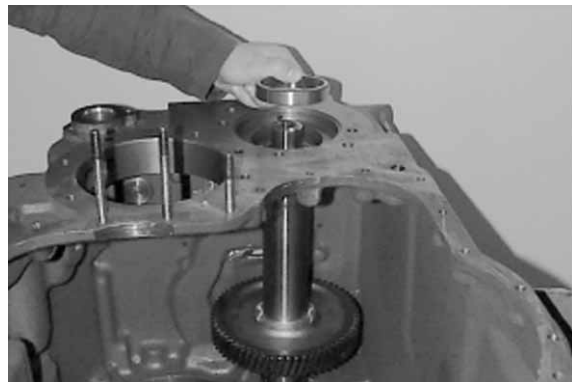

Figure 235

- (5) Adjust Axial play-Power take-off bearing-max 0.10mm by means of shim(s) and circlip.

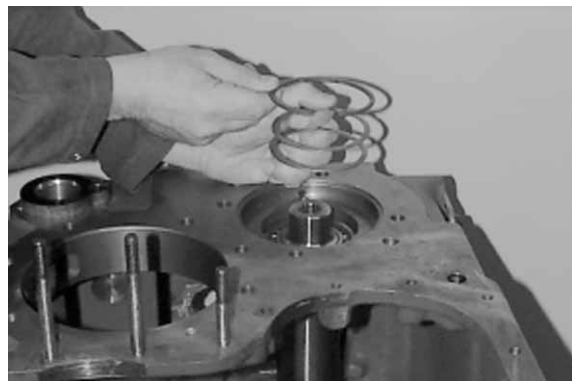

Figure 236

- (6) Tilt gearbox housing 180° .
Insert sealing disk(Arrow), with the concave side showing downward, into the housing bore until contact is obtained.

- ※ Wet contact face with Loctite(Type No. 262).
- ※ Do not damage the centric orifice hole \varnothing 0.8mm during the installation of the sealing disk.

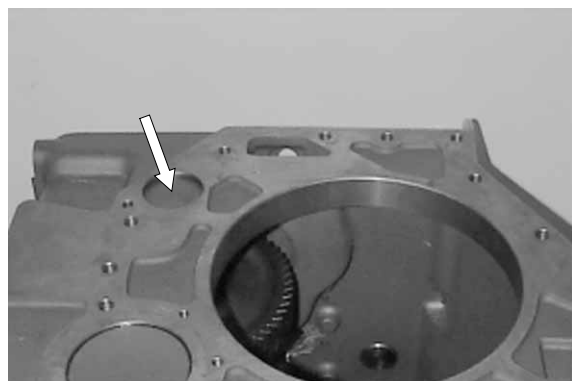

Figure 237

Reassemble Multi-disk clutch K3/K4

- (1) Lift plate carrier, with the K4-side showing downward, into the clamping ring and fix it. Now, tilt plate carrier 180°. Insert both roll pins (6×24 and 3.5×24) flush-mounted into the end face-side bore of the plate carrier, see Arrow/figure 239.

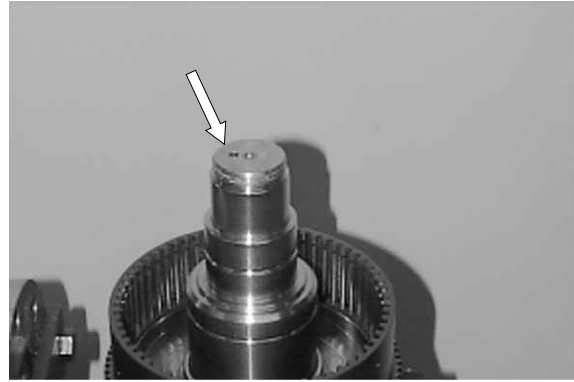

Figure 239

- (2) Tilt plate carrier 180°. Wet both roll pins (Arrows) with Loctite (Type No. 262) and install them.

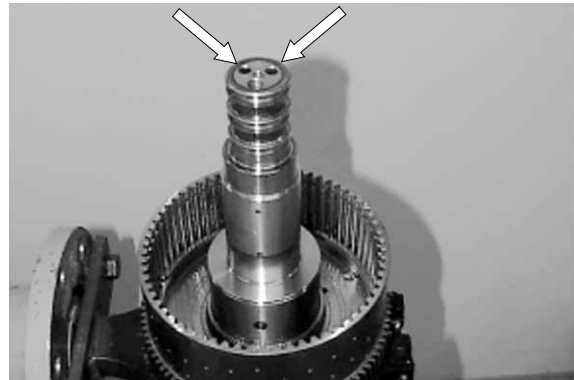

Figure 240

- (3) Insert purge valve (Arrow) flush-mounted, with the chamfer showing downward.

※ Special tool
Settling tool 5870 320 019



Figure 241

- (4) Insert both O-rings scrollfree into the ring grooves of the piston, see Arrows.

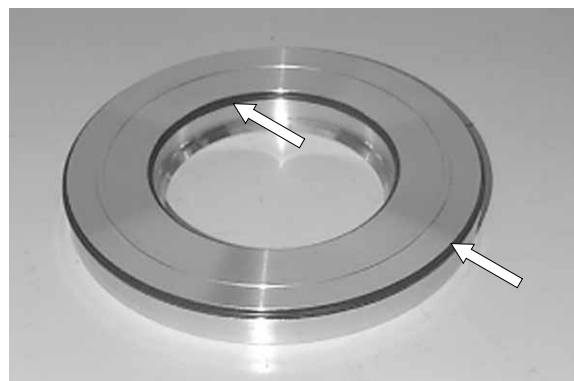

Figure 242

- (5) Oil O-rings and piston bearing surfaces.

Insert piston K3 uniformly until contact is obtained.

- ※ Pay attention to the installation position of the piston, see Figure.

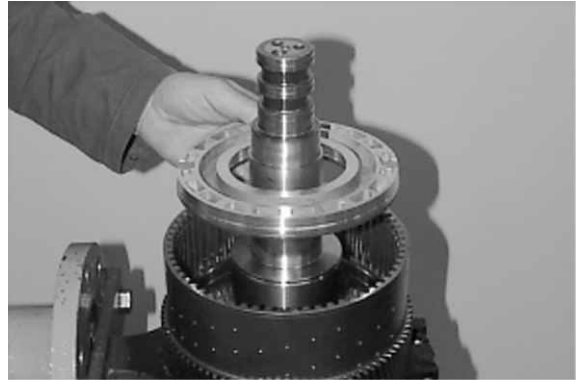

Figure 243

- (6) Introduce intermediate washer and compression spring.



Figure 244

- (7) Lay guide ring, with the chamfer (Arrow) showing upward, over the compression spring and line up the snap ring. Lift plate carrier out of the clamping ring.

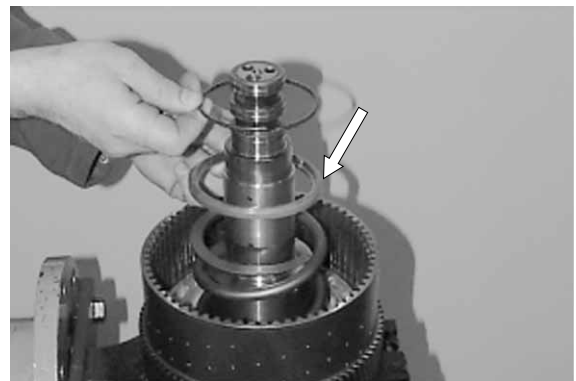

Figure 245

- (8) Preload compression spring by means of Special device and squeeze snap ring into the annular groove of the plate carrier (Arrow).

- ※ Special tool

Special device 5870 345 072

Install purge valve, spool and compression spring on the opposite side (Clutch K4) accordingly, see Figure 241~246.

Now, lift plate carrier, with the K4-side showing downward, into the clamping ring and fix it. Tilt plate carrier 180°.



Figure 246

Multi-disk clutch-K4

※ The following Draft, respective chart shows the plate stacking and the installation position of the components.

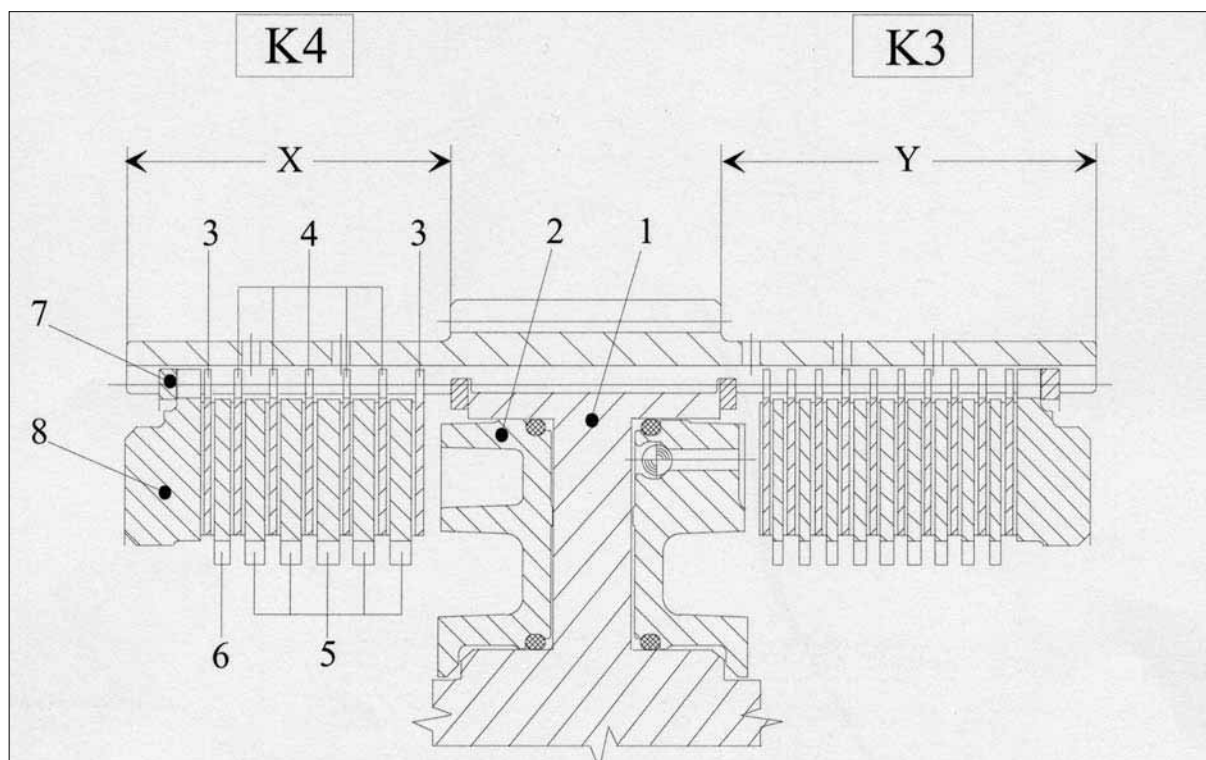

Item	Denomination	Quantity	S (mm)	Comment
1	Plate carrier	1		
2	Piston	1		
3	Outer plate	2	1.85	One-sided coated
4	Outer plate	5	2.5	Coated on both sides
5	Inner plate	5	3.5	
6	Inner plate	1	2.5 ~ 4.0	Optional
7	Snap ring	1	2.55 ~ 3.10	Optional
8	End shim	1		

Number of friction surfaces : 12

Plate clearance : 2.2 ~ 2.4mm

※ Install outer plates Item 3, with the uncoated side facing the piston, respective the end shim.

The respective clutch side can be recognized by the length of the plate carrier, see Draft.

K4 = Dimension **X** (short plate-carrier side)

K3 = Dimension **Y** (long plate-carrier side)

Check Plate clearance - $K4 = 2.2 \sim 2.4\text{mm}$ (Figure 249 ~ 251) :

※ To ensure a faultless measuring result, install the plate pack for the present without oil.

(1) Install the plate pack according to the Draft, respective chart.

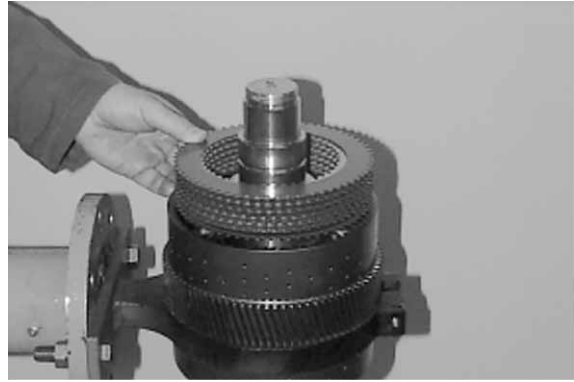

Figure 249

(2) Introduce the end shim and fix it by means of snap ring.



Figure 250

(3) Press end shim on with about 10kg and set dial indicator to "Zero".

Now, press end shim against the snap ring(upward) and read the plate clearance on the dial indicator.

※ In case of a deviation from the required plate clearance = $2.2 \sim 2.4\text{mm}$, correct with corresponding inner plate item 6 (optional $s = 2.5$ to 4.0mm) or and snap ring item 7(optional).

After the performed adjustment of the plate clearance, disassemble the plate pack, oil the plates, and install them again.

※ Special tool

Magnetic stand 5870 200 055

Dial indicator 5870 200 057

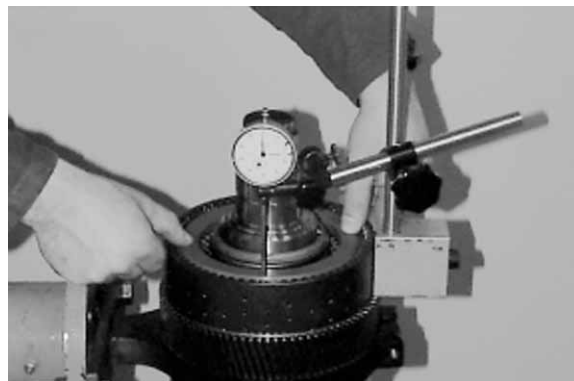

Figure 251

Preassemble and install Spur gear K4 (Figure 252 ~ 257) :

- (4) The Figure on the right shows the components of spur gear K4.

- 1 Bearing inner race
- 2 Bearing outer race
- 3 Shim (optional, empirical value $s = 5.4\text{mm}$)
- 4 Spur gear

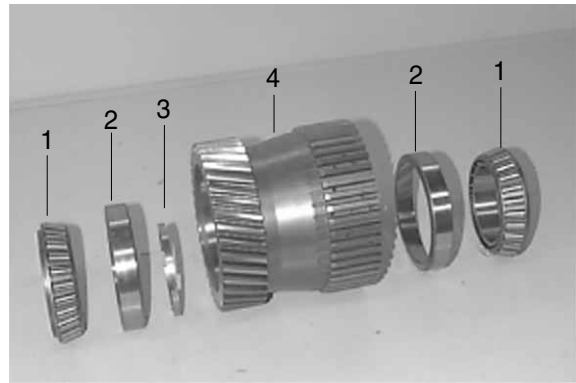

Figure 252

- (5) Check Axial play - Spur gear bearing $0.0 \sim 0.05\text{mm}$

Install components, according to Figure 252. Preload tapered roller bearing with about 5ton, and determine axial play with dial indicator.

- ※ In case of deviations from the required axial play, correct with corresponding shim (Item 3/Figure 252).

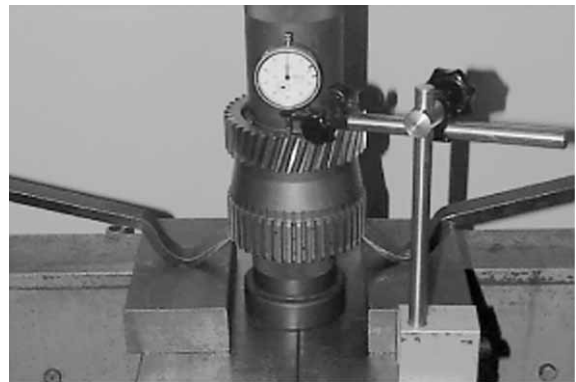

Figure 253

- (6) Heat bearing inner race and line it up until contact is obtained.



Figure 254

- (7) Line up the determined shim (see Figure 252 and 253), with the oil groove showing upward.



Figure 255

(8) Introduce spur gear until all inner plates are accommodated.



Figure 256

(9) Heat bearing inner race (spur gear bearing) and position it against shoulder.

※ Use protective gloves.



Figure 257

(10) Heat bearing inner race (spur gear bearing) and position it against shoulder.

※ Use protective gloves.



Figure 258

Multi-disk clutch-K3

※ The following Draft, respective chart shows the plate stacking and the installation position of the components.

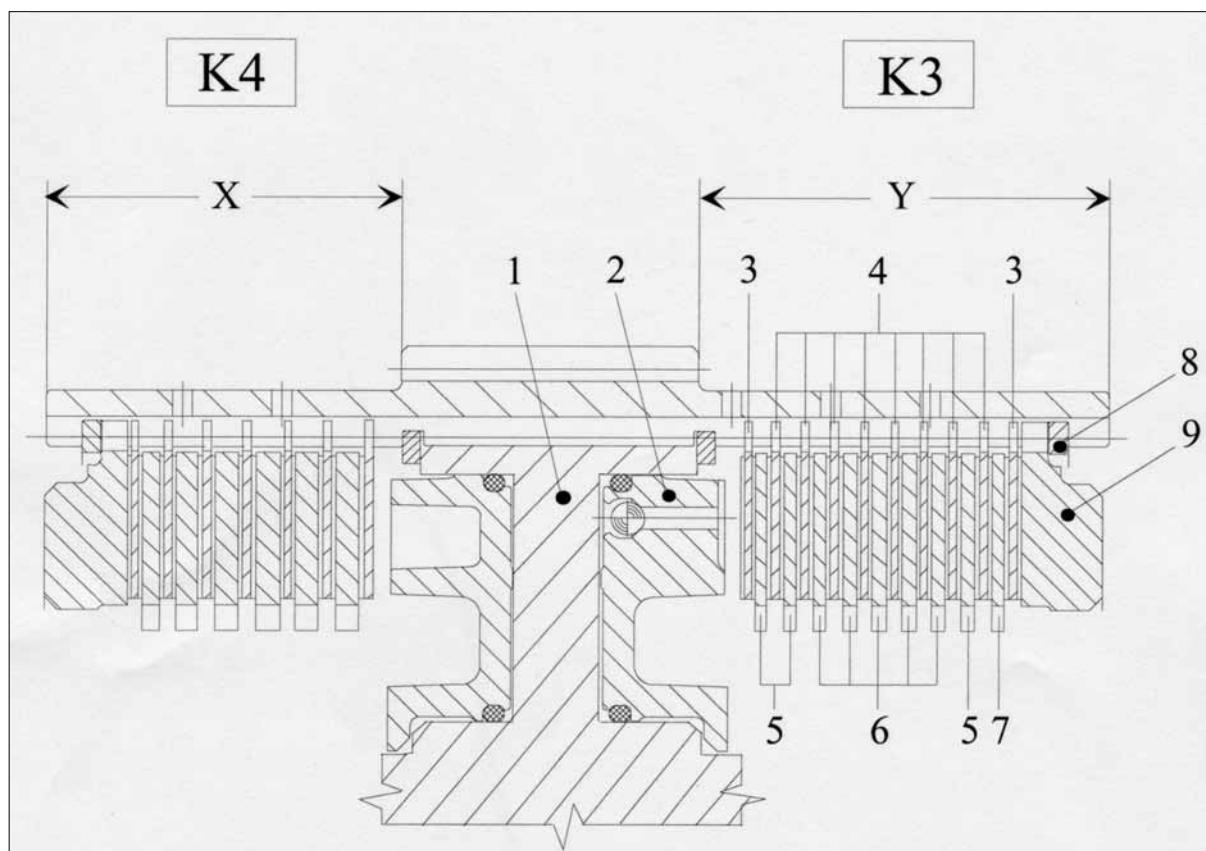

Item	Denomination	Quantity	S (mm)	Comment
1	Plate carrier	1		
2	Piston	1		
3	Outer plate	2	1.85	One-sided coated
4	Outer plate	8	2.5	Coated on both sides
5	Inner plate	3	2.5	
6	Inner plate	5	3.0	
7	Inner plate	1	2.5 ~ 4.0	Optional
8	Snap ring	1	2.55 ~ 3.10	Optional
9	End shim	1		

Number of friction surfaces : 18

Plate clearance : 2.6 ~ 2.8mm

※ Install outer plates item 3, with the uncoated side facing the piston, respective the end shim.

The respective clutch side can be recognized by the length of the plate carrier, see Draft.

K3 = Dimension Y (long plate-carrier side)

K4 = Dimension X (short plate-carrier side)

Check plate clearance $K3 = 2.6 \sim 2.8\text{mm}$ (Figure 260 ~ 262) :

※ To ensure a faultless measuring result, install the plates for the present without oil.

(1) Install the plate pack according to the Draft, respective the chart.



Figure 260

(2) Introduce the end shim and fix it by means of snap ring.

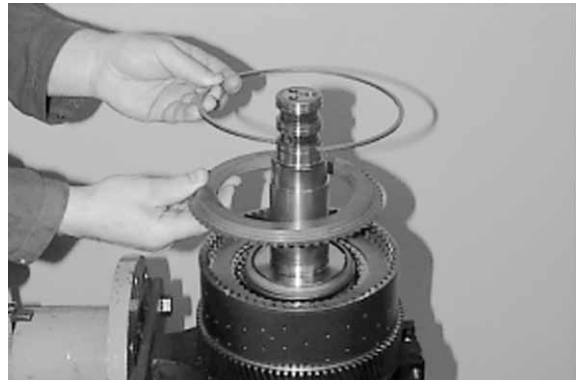

Figure 261

(3) Press the end shim on with about 10kg and set the dial indicator "Zero" (Figure 262). Now, press the end shim against the snap ring(upward), and read the plate clearance on the dial indicator.

※ In case of deviations from the required plate clearance = 2.6~2.8mm, correct with corresponding inner plate Item 7(optional $s = 2.5\sim 4.0\text{mm}$) or and snap ring item 8 (optional).

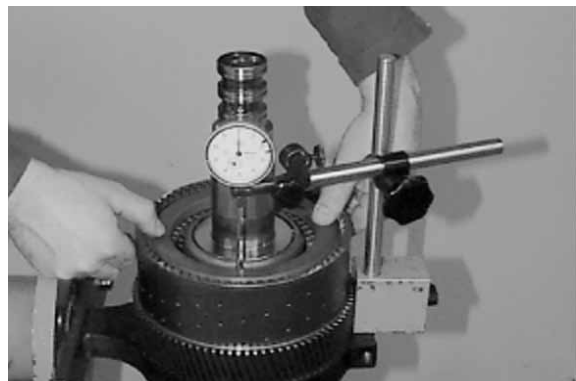

Figure 262

After the performed adjustment of the plate clearance, disassemble the plate pack, oil plates and install them again.

※ Special tool

Magnetic stand 5870 200 055

Dial indicator 5870 200 057

(4) Heat bearing inner race and line it up until contact is obtained.

※ Use protective gloves.



Figure 263

(5) Lift plate carrier out of the clamping ring.

To ensure the exact contact of the components, preload the bearing with 10 ton.

※ Support on the lower as well as on the upper bearing inner race.
Use pressure pieces.

※ Special tool

Pressure pieces 5870 506 096

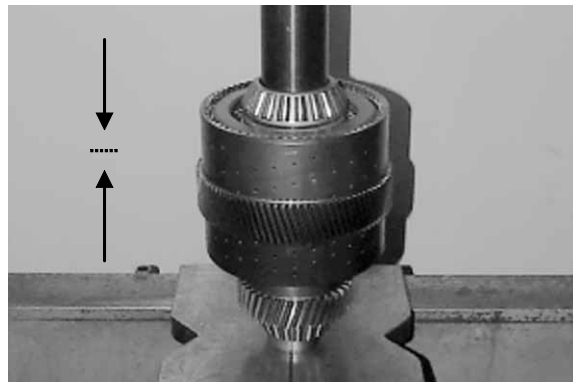

Figure 264

(6) Lift plate carrier, with the K4-side showing downward, into the clamping ring and fix it. Tilt plate carrier 90°.

Wet thread of slotted nut with Loctite (Type No. 262) and install slotted nut(Figure 265).

※ Install slotted nut, with the collar(\varnothing 60mm) facing the bearing inner race.

※ Special tool

Clamping ring 5870 654 022

Hook spanner 5870 401 118

Hook spanner 5870 401 115



Figure 265

(7) Insert bearing outer race into the spur gear K3 until contact is obtained.



Figure 266

- (8) Introduce spur gear until all inner plates are accommodated.



Figure 267

- (9) Heat roller bearing and position it against shoulder.

※ Use protective gloves.



Figure 268

- (10) Introduce bearing inner race.



Figure 269

- (11) Check function of the clutches K3 and K4 by means of compressed air.

※ At correctly installed components, the closing, respective opening of the clutches is clearly audible.

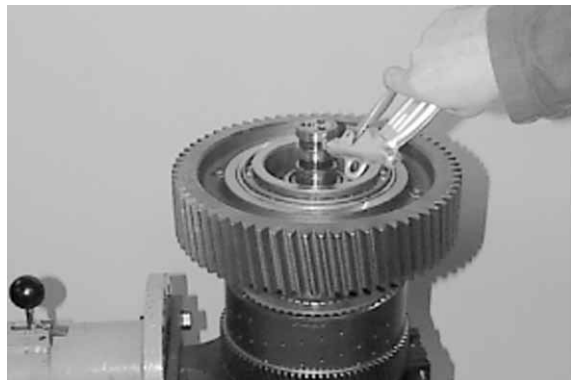

Figure 270

- (12) Squeeze in and engage rectangular rings (3EA, see Arrows).

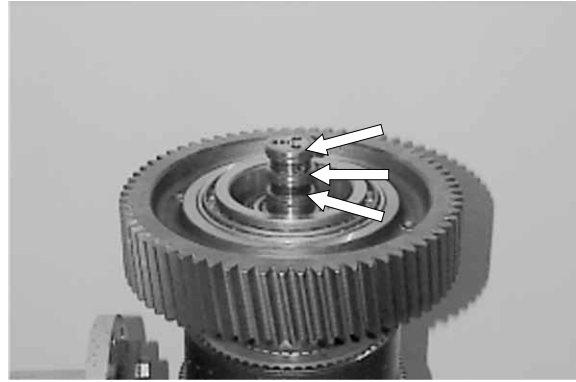

Figure 271

Reassemble Multi-disk clutch KR/K2

- (1) Lift plate carrier, with the KR-side showing downward, into the clamping ring and fix it. Tilt plate carrier 180° .
Insert both roll pins (6×24 and 3.5×24) flush-mounted into the spur gear-side bore (Arrow) of the plate carrier.

※ Special tool

Clamping ring 5870 654 022

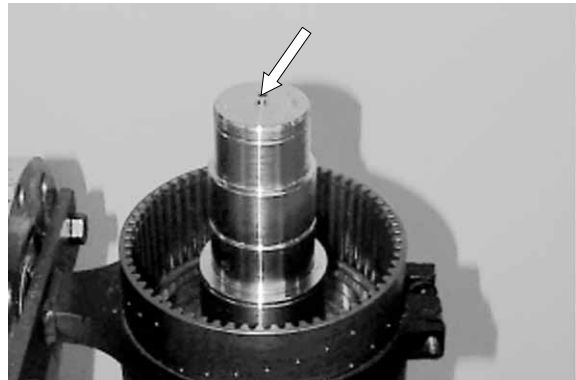

Figure 275

- (2) Tilt plate carrier 180° .
Wet both set screws (Arrows) with Loctite (Type No. 262) and install them.



Figure 276

- (3) Insert purge valve (Arrow) flush-mounted, with the chamfer showing downward.

※ Special tool

Settling tool 5870 320 019

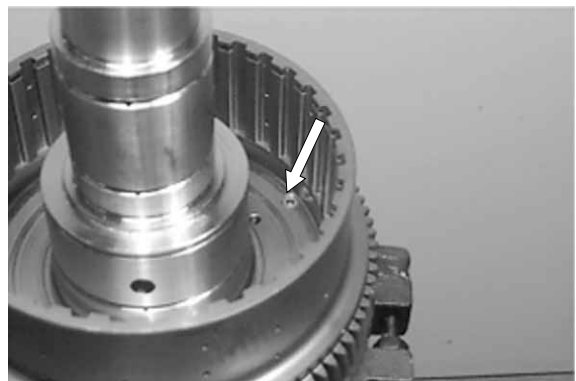

Figure 277

- (4) Lay both O-rings scrollfree into the ring grooves of the piston, see Arrows.

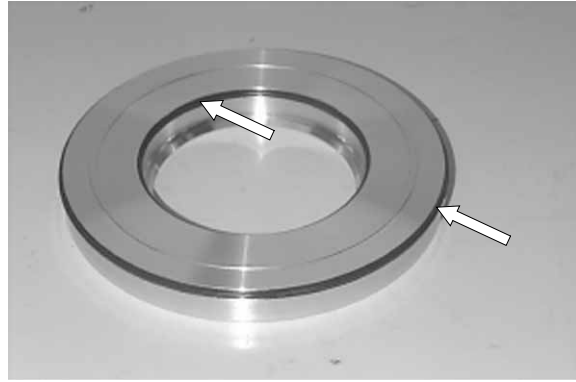

Figure 278

- (5) Oil O-rings and piston bearing surfaces.
Insert K2 piston uniformly until contact is obtained.

※ Pay attention to the installation position of the piston, see Figure.



Figure 279

- (6) Introduce intermediate plate and compression spring



Figure 280

- (7) Lay guide ring, with the chamfer(Arrow) showing upward, over the compression spring and line up the snap ring.



Figure 281

- (8) Lift plate carrier out of the clamping ring .
Preload compression spring by means of special device and squeeze snap ring into the annular groove of the plate carrier (Arrow), see Figure 282.
Install purge valve, spool and compression spring on the opposite side(KR clutch) accordingly(as Figure 277~282).
Now, lift plate carrier, with the KR-side showing downward into the clamping ring and fix it.
Tilt plate carrier 180° .

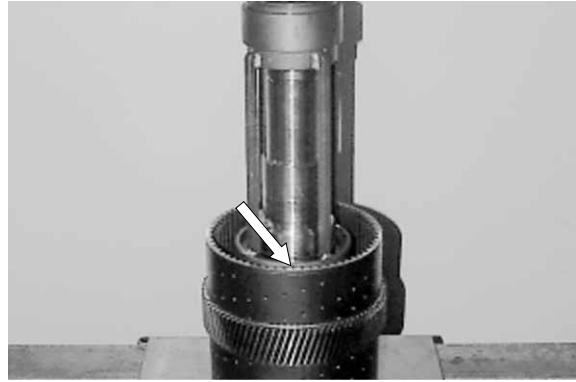
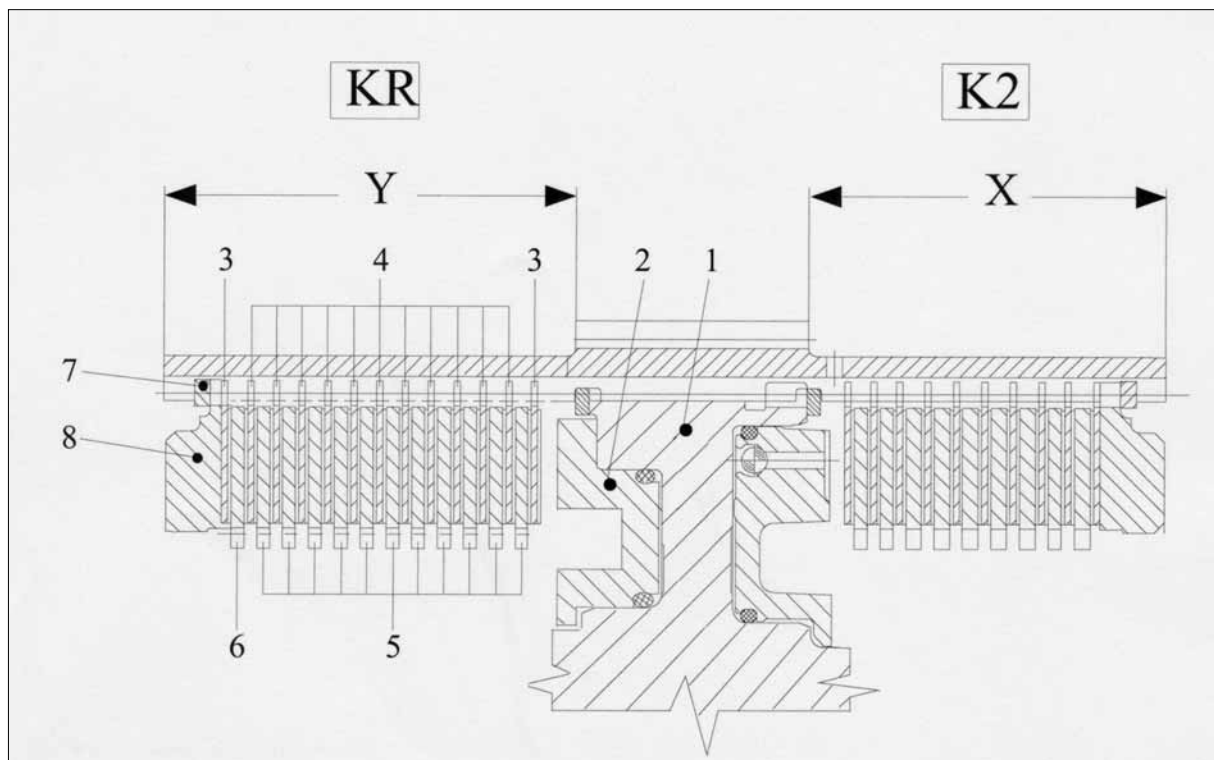

Figure 282

- ※ Special tool
Clamping ring 5870 345 072

Multi-disk clutch-KR

※ The following Draft, respective chart shows the plate stacking and the installation position of the components.



Item	Denomination	Quantity	S (mm)	Comment
1	Plate carrier	1		
2	Piston	1		
3	Outer plate	2	1.85	One-sided coated
4	Outer plate	11	2.5	Coated on both sides
5	Inner plate	11	2.5	
6	Inner plate	1	2.5 ~ 4.0	Optional
7	Snap ring	1	2.55 ~ 3.1	Optional
8	End shim	1		

Number of friction surfaces : 24

Plate clearance : 2.8 ~ 3.0mm

※ Install outer plates Item 3, with the uncoated side facing the piston, respective the end shim.

The respective clutch side can be recognized by the length of the plate carrier, see Draft.

KR = Dimension **Y** (long plate-carrier side)

K3 = Dimension **X** (short plate-carrier side)

(1) Check Plate clearance $KR = 2.8\sim 3.0\text{mm}$
(Figure 285~287):

※ To ensure a faultless measuring result,
install the plates for the present without oil.

Install plate pack according to the Draft,
respective chart.

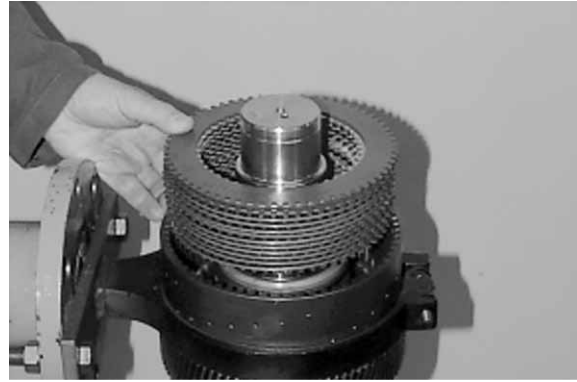

Figure 285

(2) Introduce end shim and fix it by means of
snap ring.



Figure 286

(3) Press the end shim on with about 10kg
and set the dial indicator to "Zero".
Now, press the end shim against the snap
ring(upward) and read the plate clearance
on the dial indicator.

※ In case of deviations from the required
plate clearance = $2.8\sim 3.0\text{mm}$, correct with
corresponding inner plate item 6 (optional
 2.5 to 4.0mm) or and snap ring item 7
(optional).

After the performed adjustment of the
plate clearance, disassemble the plate
pack, oil plates and install them again.

※ Special tool

Magnetic stand 5870 200 055

Dial indicator 5870 200 057

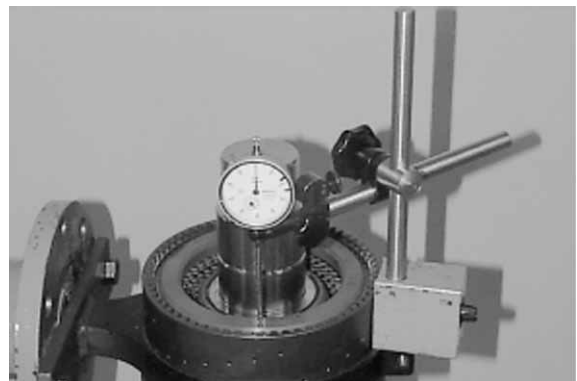

Figure 287

**Preassemble and install Spur gear KR
(Figure 288~296) :**

- (1) The Figure on the right shows the components of spur gear KR.

- 1 Bearing inner race
- 2 Shims $s = 3.0$ and $s = 3.10\text{mm}$
($\Sigma = 6.10\text{mm}$ /Empirical value)
- 3 Spur gear
- 4 Bearing inner race

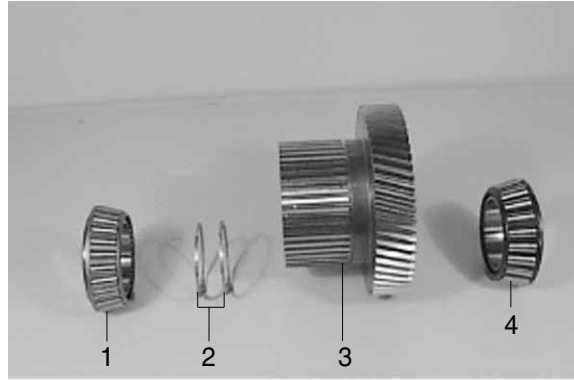

Figure 288

- (2) Check Axial play - Spur gear bearing
0.0~0.05mm.

Place spur gear over the bearing inner race.

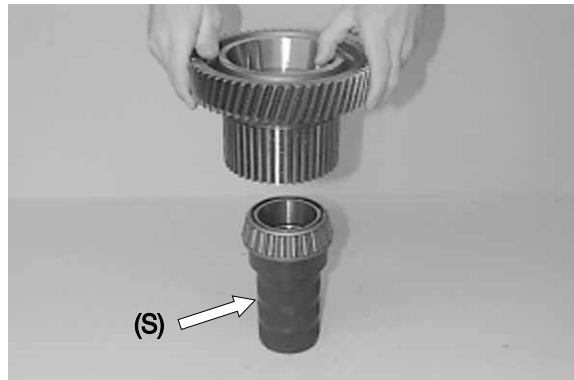

Figure 289

- (3) Introduce shims(2 pieces/ $s = 3.0$ and $s = 3.10\text{mm}$).



Figure 290

- (4) Mount bearing inner race.



Figure 291

(5) Preload the tapered roller bearing with about 5 ton and determine the axial play with dial indicator.

※ In case of deviations from the required axial play, correct with corresponding shims (Item 2/figure 288).

※ Special tool

pry bar 5870 345 036

Dial indicator 5870 200 057

Magnetic stand 5870 200 055

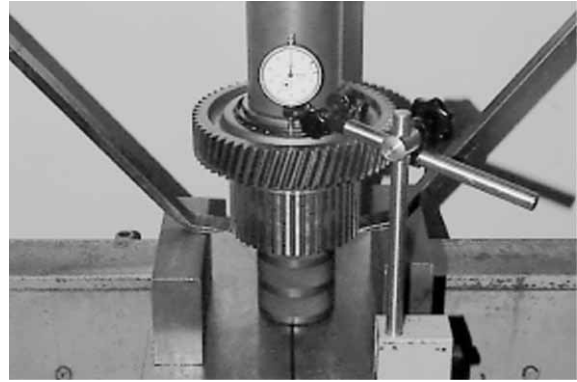

Figure 292

(6) Heat bearing inner race and position it against shoulder.

※ Use protective gloves.



Figure 293

(7) Introduce the spur gear until all inner plates are accommodated.

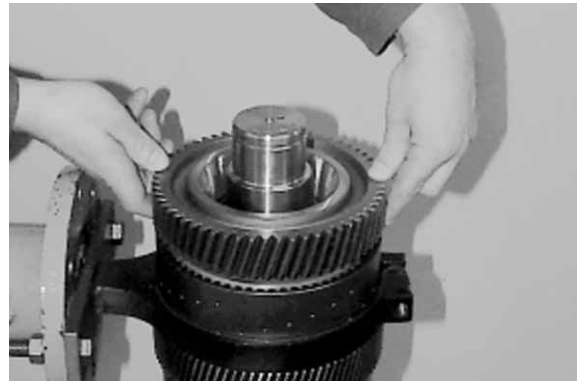

Figure 294

(8) Introduce determined shims (see Figure 289 to 292).



Figure 295

(9) Heat bearing inner race (spur gear bearing) and position it against shoulder.

※ Use protective gloves.



Figure 296

(10) Heat bearing inner race (spur gear bearing) and position it against shoulder.

※ Use protective gloves.



Figure 297

Multi-disk clutch-K2

※ The following Draft, respective chart shows the plate stacking and the installation position of the components.

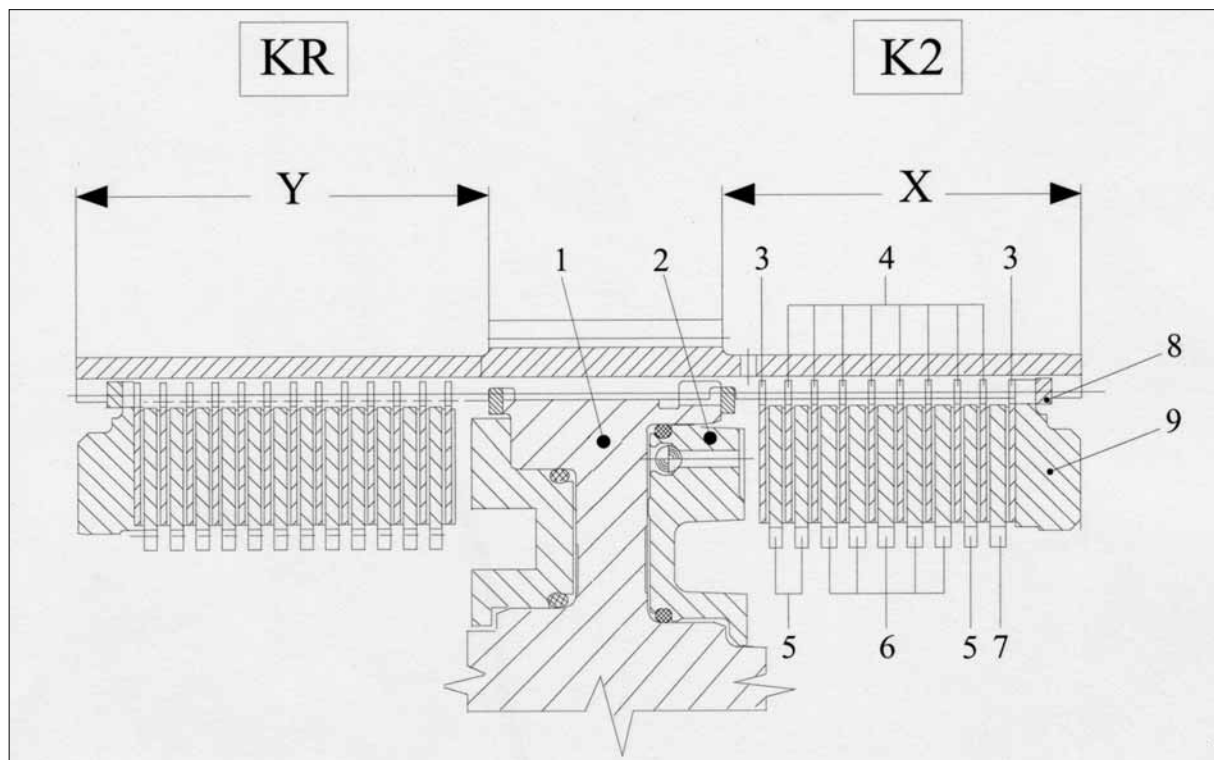

Item	Denomination	Quantity	S (mm)	Comment
1	Plate carrier	1		
2	Piston	1		
3	Outer plate	2	1.85	One-sided coated
4	Outer plate	8	2.5	Coated on both sides
5	Inner plate	3	2.5	
6	Inner plate	5	3.0	
7	Inner plate	1	2.5 ~ 4.0	Optional
8	Snap ring	1	2.55 ~ 3.10	Optional
9	End shim	1		

Number of friction surfaces : 18

Plate clearance : 2.6 ~ 2.8mm

※ Install outer plates item 3, with the uncoated side facing the piston, respective the end shim.

The respective clutch side can be recognized by the length of the plate carrier, see Draft.

K2 = Dimension X (short plate-carrier side)

KR = Dimension Y (long plate-carrier side)

Check plate clearance $K2 = 2.6 \sim 2.8\text{mm}$ (Figure300 ~ 302) :

※ To ensure a faultless measuring result, install the plates for the present without oil.

(1) Install the plate pack according to the draft, respective chart.



Figure 300

(2) Introduce end shim and fix it by means of snap ring.



Figure 301

(3) Press the end shim on with about 10kg and set the dial indicator to "Zero".
Now, press the end shim against the snap ring (upward) and read the plate clearance on the dial indicator.

In case of deviations from the required plate clearance = $2.6 \sim 2.8\text{mm}$, correct with corresponding inner plate item 7 (optional $s = 2.5 \sim 4.0\text{mm}$) or and snap ring item 8 (optional).

After the performed adjustment of the plate clearance, disassemble the plate pack, oil the plates and install them again.

※ Special tool

Dial indicator 5870 200 057

Magnetic stand 5870 200 055

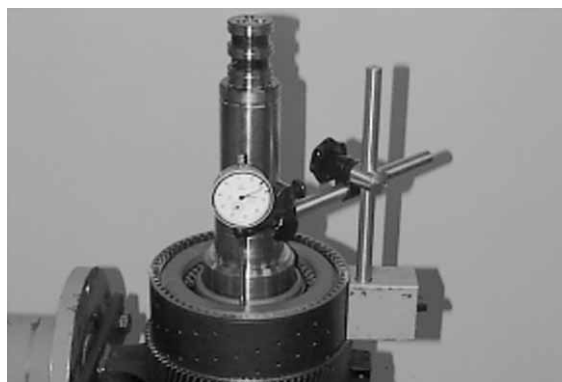

Figure 302

Preassemble and install spur gear K2 (Figure 303 ~ 312) :

- (1) Supercool gear wheel 1 (about 80°C) and heat gear wheel 2 (about 120°C). Squeeze snap ring in (Arrow), preload, and join both parts together by means of hydraulic press until the snap ring snaps into the annular groove of the gear wheel 2.

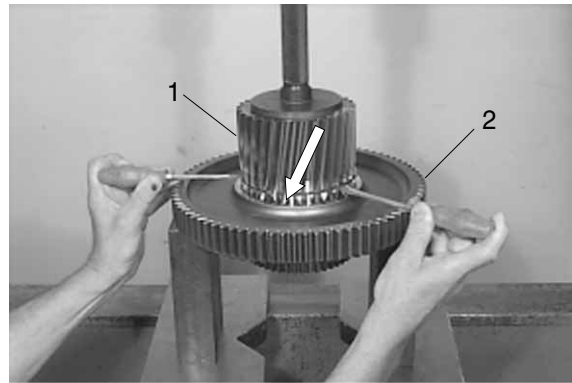

Figure 303

- (2) Adjust Axial play - Spur gear bearing 0.05 ~ 0.15mm (Figure 304 ~ Example C)

The Figure on the right shows the components of the spur gear bearing.

- 1 Bearing inner race
- 2 Shim (optional)
- 3 Spur gear complete
- 4 Bearing inner race

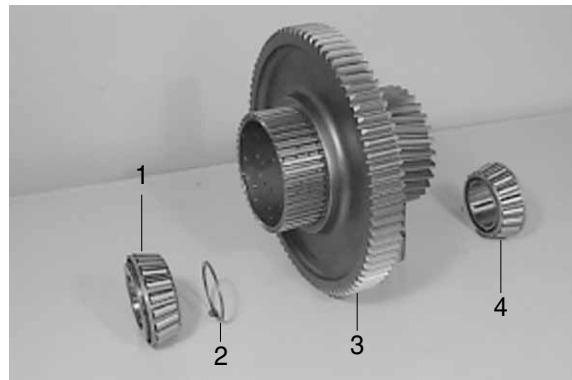

Figure 304

- (3) Place spur gear over the bearing inner race.

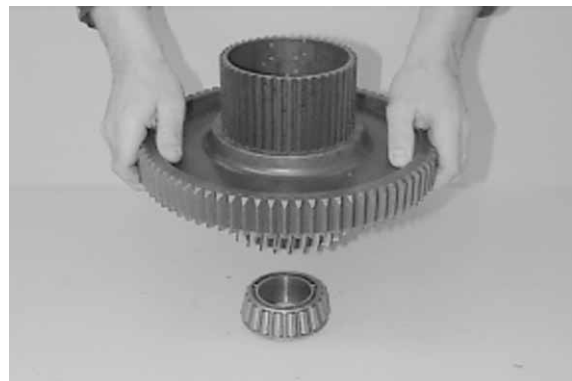

Figure 305

- (4) Introduce bearing inner race.



Figure 306

(5) Determine Dimension I (bearing dimension)

Dimension I e.g. 76.27mm

※ Special tool

Digital Depth gauge 5870 200 072

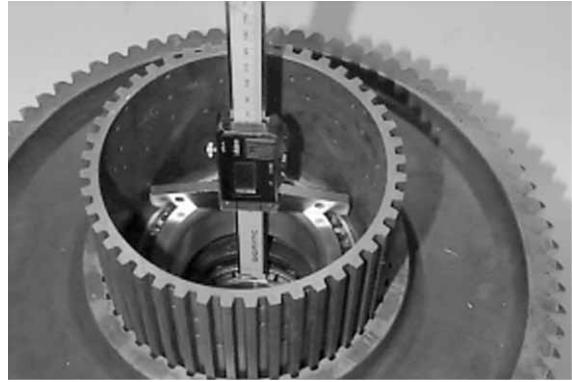

Figure 307

(6) Determine Dimension II (shaft dimension).

Dimension II e.g. 74.14mm

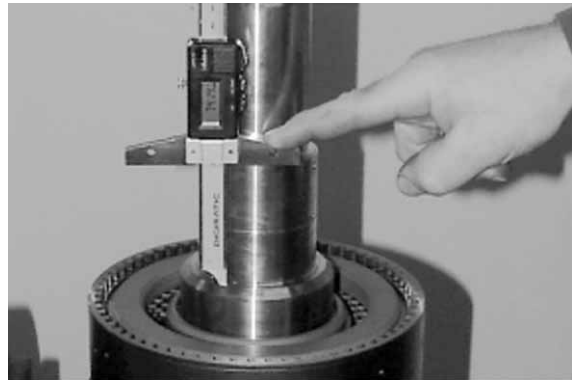

Figure 308

EXAMPLE C

Dimension I e.g. 76.27mm

Dimension II e.g. - 74.14mm

Difference = 2.13mm

Axial play e.g. + 0.07mm

Gives shim s = 2.20mm

(7) Heat bearing inner race and line it up until contact is obtained.

※ Use protective gloves.



Figure 309

(8) Introduce spur gear until all inner plates are accommodated.



Figure 310

(9) Line up shim(e.g. $s=2.20\text{mm}$, see Example).



Figure 311

(10) Heat bearing inner race (spur gear bearing) and line it up until contact is obtained.

※ Use protective gloves.



Figure 312

(11) aHeat bearing inner race(clutch bearing) and position it against shoulder.

※ Use protective gloves.



Figure 313

(12) Lift plate carrier out of the clamping ring.
To ensure the exact contact of the components, preload bearing with 10 ton.

- ※ Support on the lower as well as on the upper bearing race. Use pressure pieces.
- ※ Special tool
Pressure pieces 5870 506 096

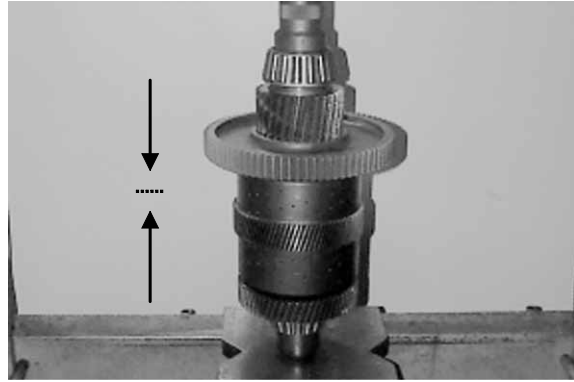

Figure 314

Lift plate carrier into the clamping ring and fix it.

(13) Tilt clutch 90°

· **K2-Side:**

Wet thread of slotted nut with Loctite (Type No. 262) and install it (Figure 315).

- ※ Install slotted nut with the chamfer facing the bearing inner race.

· Torque limit : 81.6kgf · m(590lbf · ft)

※ Special tool

Clamping ring 5870 064 022

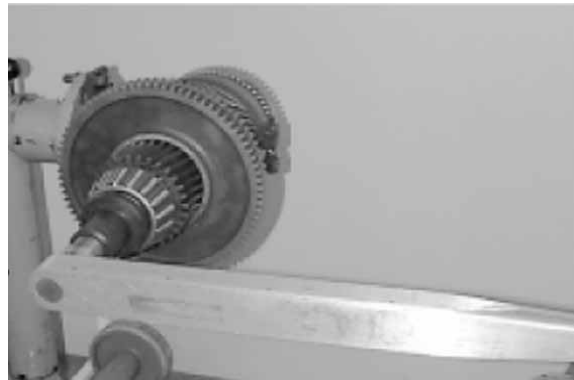

Figure 315

· **KR-Side:**

Wet thread of slotted nut with Loctite (Type No. 262) and install it.

- ※ Install slotted nut, with the collar(∅ 76mm) facing the bearing inner race.

· Torque limit : 81.6kgf · m(590lbf · ft)

※ Special tool

Hook spanner 5870 401 099



Figure 316

(14) Check function of clutches K3 and K4 by means of compressed air (Figure 317).

- ※ At correctly installed components, the closing, respective opening of the clutches is clearly audible.

Squeeze in and engage rectangular ring (see Arrows).

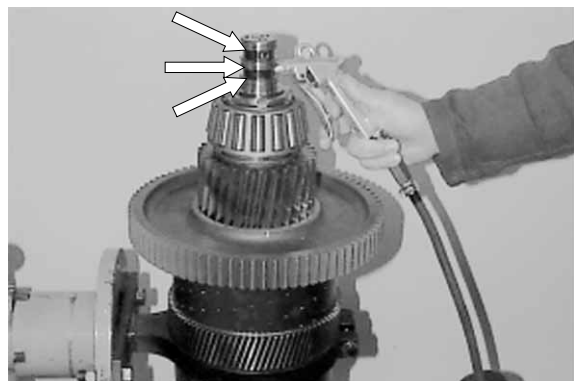

Figure 317

Reassemble Multi-disk clutch KV/K1

- (1) Lift plate carrier, with the KV-side showing downward, into the clamping ring and fix it. Tilt plate carrier 180° . Insert both roll pins(6×24 and 3.5×24) flush-mounted into the end face-side bore of the plate carrier (Arrow).

※ Special tool
Clamping ring 5870 654 022

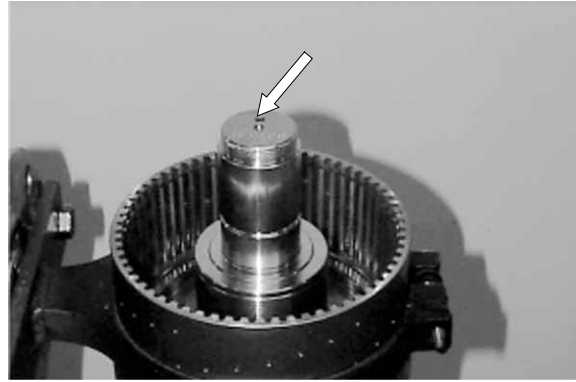

Figure 320

- (2) Tilt plate carrier 180° . Wet both set screws(Arrows) with Loctite (Type No. 262) and install them.



Figure 321

- (3) Drive purge valve(Arrow) flush-mounted in, with the chamfer showing downward.

※ Special tool
Settling tool 5870 320 019

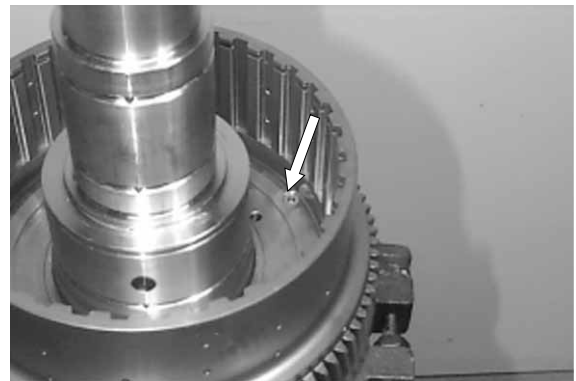

Figure 322

- (4) Lay both O-rings scrollfree into the ring grooves of the piston, see Arrows.

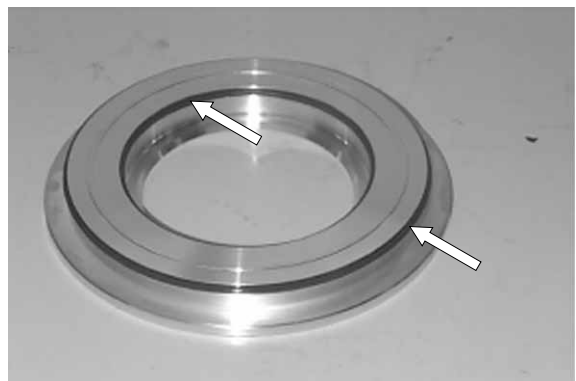

Figure 323

- (5) Oil O-rings and piston bearing surfaces.
Insert K1-piston uniformly against shoulder.

※ Pay attention to the installation position of the piston, see Figure.

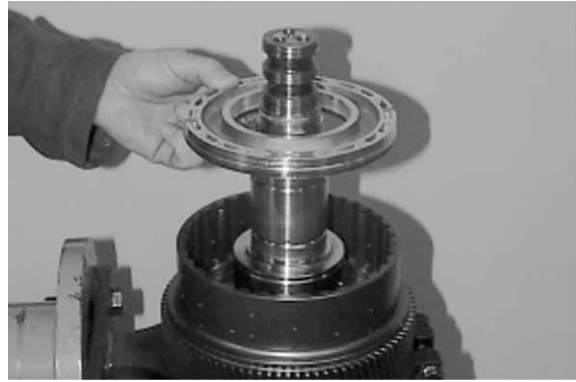

Figure 324

- (6) Introduce intermediate washer and compression spring.



Figure 325

- (7) Lay guide ring, with the chamfer (Arrow) showing upward, over the compression spring and line up the snap ring.



Figure 326

- (8) Lift the plate carrier out of the clamping ring. Preload compression spring by means of Special device and squeeze snap ring into the annular groove of the plate carrier (Arrow) - see Figure 327. Install purge valve, spool and compression spring on the opposite side (KV-clutch) accordingly.
Now, lift the plate carrier, with the KV-side showing downward, into the clamping ring and fix it.

Tilt plate carrier 180°

※ Special tool
Pressure piece

5870 345 072



Figure 327

Multi-disk clutch-KV

※ The following Draft, respective Chart shows the plate stacking and the installation position of the components.

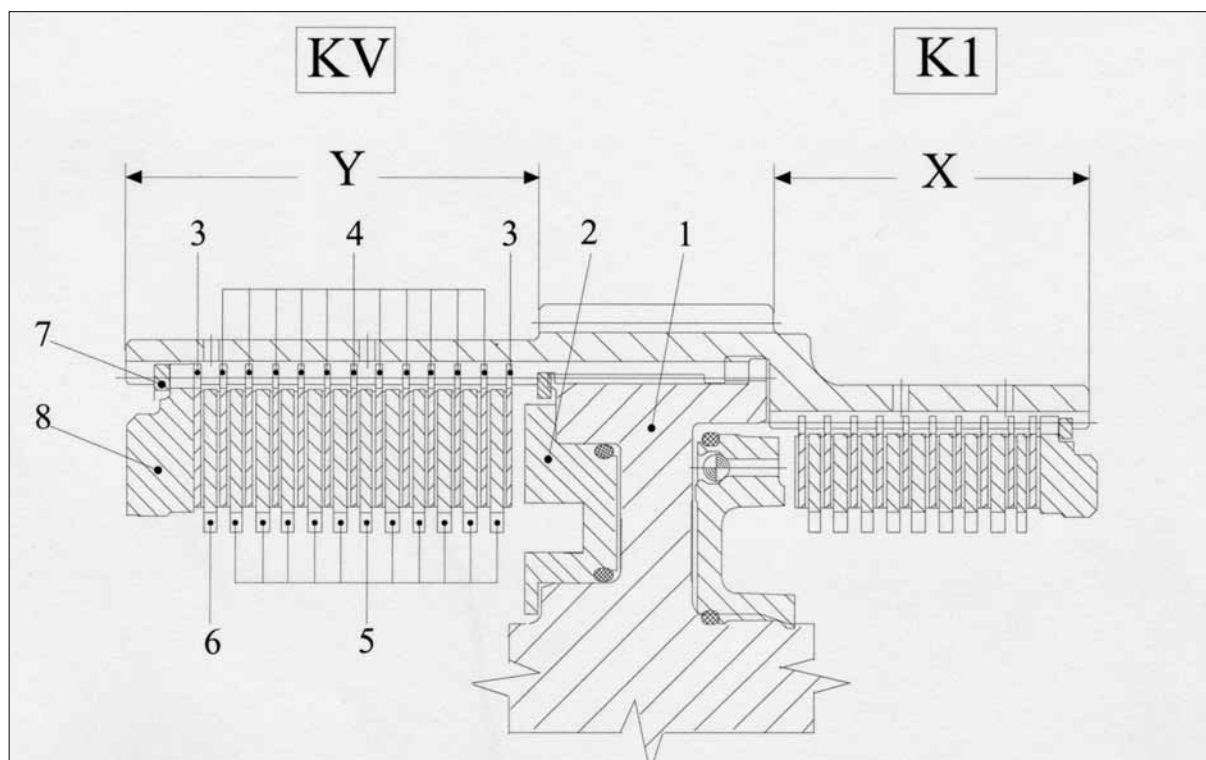

Item	Denomination	Quantity	S (mm)	Comment
1	Plate carrier	1		
2	Piston	1		
3	Outer plate	2	1.85	One-sided coated
4	Outer plate	11	2.5	Coated on both sides
5	Inner plate	11	2.5	
6	Inner plate	1	2.5 ~ 4.0	Optional
7	Snap ring	1	2.55 ~ 3.1	Optional
8	End shim	1		

Number of friction surfaces : 24

Plate clearance : 2.8 ~ 3.0mm

※ Install outer plates item 3, with the uncoated side facing the piston, respective the end shim.

The respective clutch side can be recognized by the length, respective. \varnothing of the plate carrier, see Draft.

KV = Dimension Y (long plate-carrier side, resp. great \varnothing)

K1 = Dimension X (short plate-carrier side, resp. small \varnothing)

**Check plate clearance KV = 2.8~3.0mm
(Figure 330~332):**

※ To ensure a faultless measuring result,
install the plates for the present without oil.

(1) Install the plate pack according to the
Draft, respective chart.

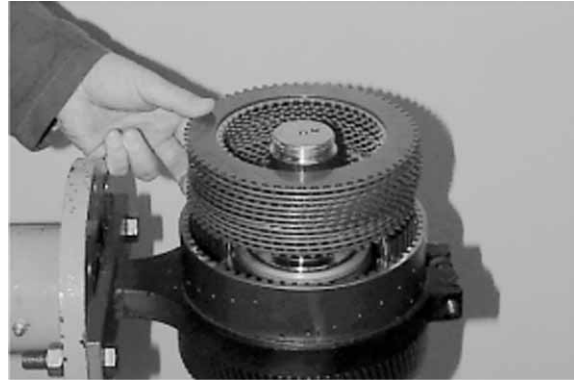

Figure 330

(2) Introduce the end shim and fix it by means
of snap ring.

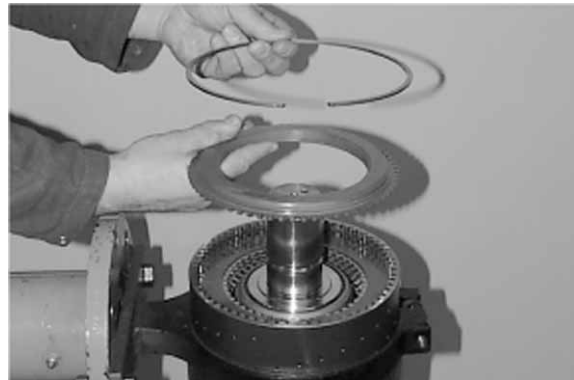

Figure 331

(3) Press the end shim on with about 10kg
and set the dial indicator to "Zero".
Now, press the end shim against the snap
ring(upward), and read the plate clearance
on the dial indicator.

※ In case of deviations from the required
plate clearance = 2.8~3.0mm, correct with
corresponding inner plate item 6 (optional
s = 2.5~4.0) or and snap ring(optional).
After the performed adjustment of the
plate clearance disassemble the plate
pack, oil plates and install them again.

※ Special tool

Magnetic stand 5870 200 055

Dial indicator 5870 200 057

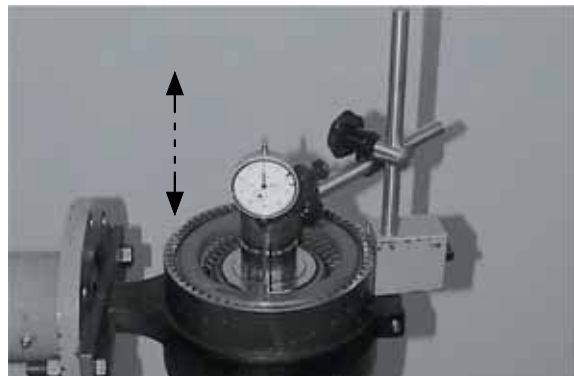

Figure 332

**Pre-assemble and install Spur gear KV
(Figure 335~343):**

(1) The Figure on the right shows the components of spur gear KV.

- 1 Bearing inner race
- 2 Bearing outer race
- 3 Ring
- 4 Shim(s) optional, empirical value $s = 1.7\text{mm}$
- 5 Spur gear

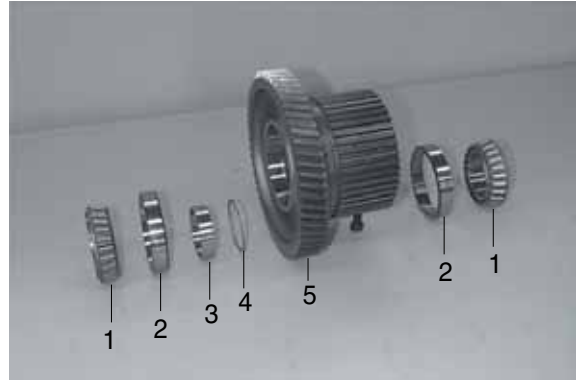

Figure 335

Check Axial play - Spur gear bearing
0.0~0.05mm.

(2) Install both bearing outer races(2) and place spur gear over the bearing inner race.



Figure 336

(3) Introduce shim(s) 4 and ring 3.



Figure 337

(4) Introduce taper roller bearing.



Figure 338

(5) Preload the tapered roller bearing with about 5ton.

※ In case of deviations from the required axial play, correct with corresponding shim (Item 4 / Figure 335).

※ Special tool

Pry bar	5870 345 036
Magnetic stand	5870 200 055
Dial indicator	5870 200 057

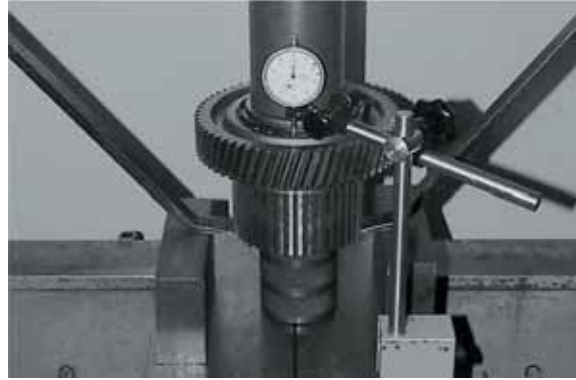

Figure 339

(6) Heat bearing inner race and position it against shoulder.

※ Use protective gloves.



Figure 340

(7) Line up shim (see Figure 335~339) and ring.

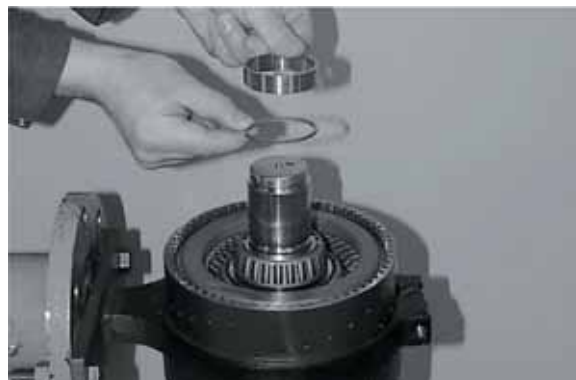

Figure 341

(8) Introduce spur gear until all inner plates are accommodated.



Figure 342

(9) Heat bearing inner race(spur gear bearing) and position it against shoulder.

※

Use protective gloves.



Figure 343

(10) Heat bearing inner race(clutch bearing) and position it against shoulder.

※ Use protective gloves.

Tilt plate carrier 180° .



Figure 344

Multi-disk clutch-K1

※ The following Draft, respective chart shows the plate stacking and the installation position of the components.

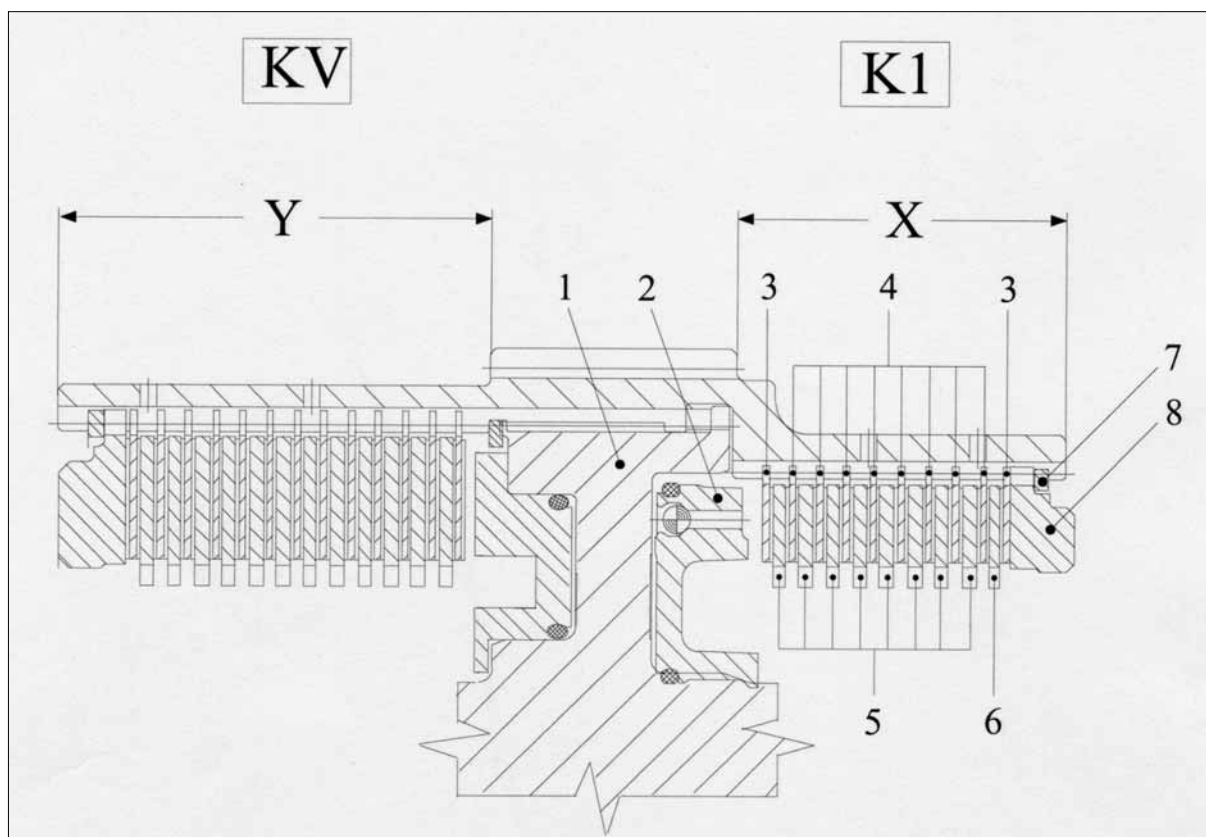

Item	Denomination	Quantity	S (mm)	Comment
1	Plate carrier	1		
2	Piston	1		
3	Outer plate	2	1.85	One-sided coated
4	Outer plate	8	2.5	Coated on both sides
5	Inner plate	8	2.5	
6	Inner plate	1	2.5 ~ 3.5	Optional
7	Snap ring	1	2.1~ 2.5	Optional
8	End shim	1		

Number of friction surfaces : 18

Plate clearance : 2.6 ~ 2.8mm

※ Install outer plates item 3, with the uncoated side facing the piston, respective the end shim.

The respective clutch side can be recognized by the length, respective ϕ of the plate carrier, see Draft.

KV = Dimension Y (long plate-carrier side, respective great ϕ)

K1 = Dimension X (short plate-carrier side, respective small ϕ)

Check plate clearance $K1 = 2.6\sim 2.8\text{mm}$
(Figure 350~352).

※ To ensure a faultless measuring result,
install the plates for the present without oil.

(1) Install plate pack according to the Draft,
respective the Chart.



Figure 350

(2) Introduce the end shim and fix it by means
of snap ring.



Figure 351

(3) Press the end shim on with about 10kg
and set the dial indicator to "Zero".
Now, press the end shim against the snap
ring (upward), and read the plate clearance
on the dial indicator.

※ In case of deviations from the required
plate clearance = $2.6\sim 2.8\text{mm}$, correct with
corresponding inner plate item 6 (optional
 $2.5\sim 3.5\text{mm}$) or and snap ring item 7
(optional).

After the performed adjustment of the
plate clearance, disassemble the plate
pack, oil plates and install them again.

※ Special tool

Magnetic stand 5870 200 055

Dial indicator 5870 200 057

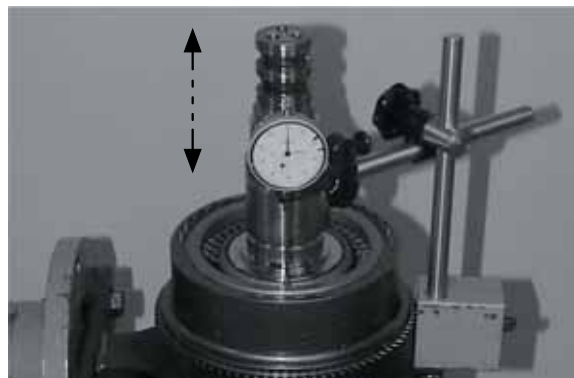

Figure 352

**Pre-assemble and install Spur gear K1
(Figure 353~360):**

(1) The Figure on the right shows the components of spur gear K1.

1 Ball bearing (complete)

2 Snap ring

3 Spur gear

※ Prior to assemble the components, align plate pack by means of the spur gear radially and center it, see figure 354.

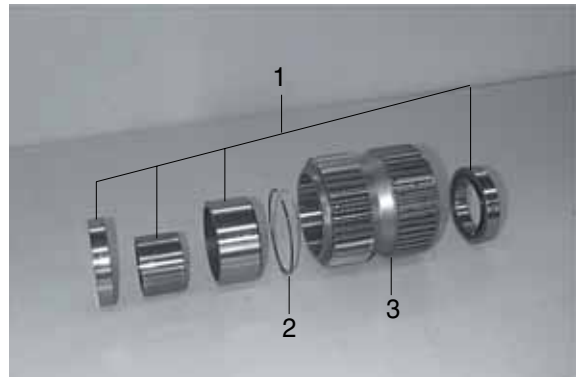

Figure 353



Figure 354

(2) Install snap ring.



Figure 355

(3) Introduce bush, with the end face-side collar (Arrow) facing the snap ring.



Figure 356

(4) Press ball bearing in until contact is obtained.

- ※ Install ball bearing, with the lubricating groove (Arrow) showing downward. Apply the pressing-in tool only on the bearing outer race.



Figure 357

(5) Heat ball bearing and line it up until contact is obtained.

- ※ Lubricating groove (Arrow) must show upward.
- ※ Use protective gloves.



Figure 358

(6) Line up the bush.



Figure 359

(7) Heat spur gear about 120°C and introduce it until all inner plates are accommodated.

- ※ Use protective gloves.



Figure 360

(8) Line up shim = 1.2mm.



Figure 361

(9) Heat bearing inner race and line it up until contact is obtained.

※ Use protective gloves.



Figure 362

(10) Lift plate carrier out of the clamping ring.
To ensure the exact contact of the components, prelaod bearing with 10ton (Figure 363).

※ Support on the lower as well as on the upper bearing inner race.
Use pressure pieces.

※ Special tool
Pressure pieces 5870 506 096



Figure 363

(11) Lift plate carrier into the clamping ring, fix and tilt it 90°.

Wet thread of slotted nut with Loctite, (Type No. 262) and install slotted nut.

※ Install slotted nut, with the collar facing the bearing inner race.

· Torque limit : 56.1kgf · m(40.6lbf · m)

Install opposite slotted nut(KV-side) accordingly.

※ Special tool
Hook spanner 5870 401 099



Figure 364

(12) Check function of the clutches KV and K1 by means of compressed air.

- ※ At correctly installed components, the closing, respective opening of the clutches is clearly audible.



Figure 365

(13) Squeeze in and engage rectangular rings (3EA, see Arrows).



Figure 366

Install Counter shaft gear and Multi-disk clutches

- (1) Adjust Axial play of the Counter shaft gear bearing 0.0~0.05mm(Figure 366, Example D₂):

Determine Dimension I (shaft dimension).

Dimension I e.g. 61.57mm

※ Special tool

Digital Depth gauge 5870 200 072

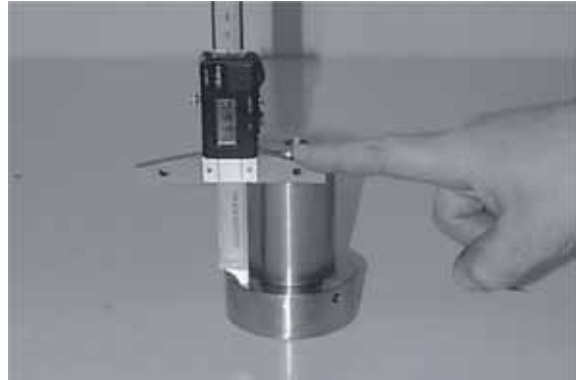

Figure 367

- (2) Measure Dimension II (housing dimension) from the locating face of the bearing inner race to the locating face of the axle.

Dimension II e.g. 0.52mm

EXAMPLE D1

Dimension I e.g. 61.57mm

Dimension II e.g. - 0.52mm

gives Dimension X 61.05mm

required Axial play e.g. - 0.03mm

gives Installation dimension 61.02mm

Y e.g.



Figure 368

- (3) Install both bearing inner races.

Lay preassembled counter shaft gear upon the surface plate and determine Dimension III (bearing dimension).

Dimension III e.g. 59.52mm

EXAMPLE D2

Dimension Y (installation dimension) 61.02mm

Dimension III (bearing dimension) - 59.52mm

gives shim e.g. s = 1.50mm

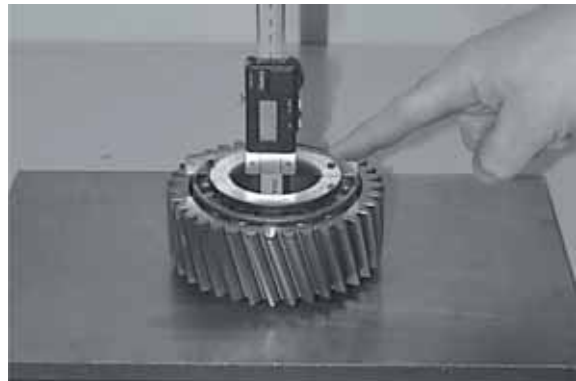

Figure 369

※ The assembly of the shim as well as of the countershaft axle can be performed only after the installation of the clutches.

(4) Position countershaft gear (along with bearing inner races), see Figure 370.



Figure 370

(5) Insert bearing outer races KV/K1, KR/K2 and K3/K4 into the housing bores until contact is obtained, see Arrows.

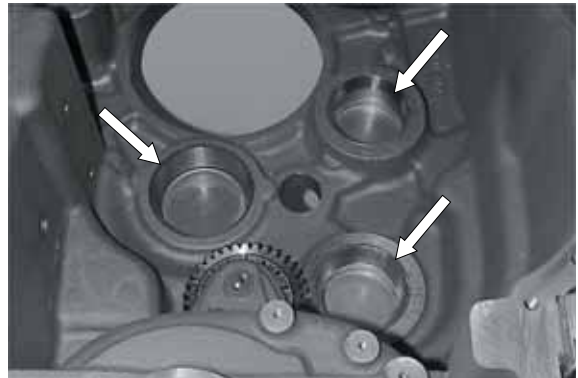

Figure 371

(6) Position clutch KV/K1, using lifting device.

※ Special tool

Set of eye bolts

5870 204 002



Figure 372

(7) Position clutch KR/K2.



Figure 373

- (8) Check installation position of the countershaft gear(Arrow) once more and correct if necessary.

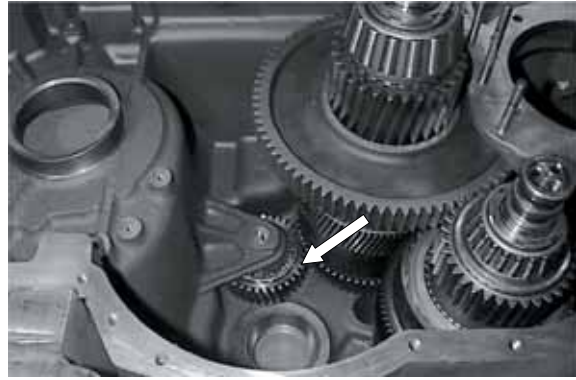

Figure 374

- (9) Locate the spur gear K3 by means of Special device and eye bolt (Arrow) axially.

※ The spur gear fixing prevents the slipping out of the plates during the lifting into position of the clutch.

※ Special tool

Assembly jig 5870 345 033

Eye bolt 5870 204 066



Figure 375

- (10) Lift clutch KR/K2 slightly, displace it in direction of arrow, and position clutch K3/K4.

Now, remove the Special device again.



Figure 376

Interaxle differential

(1) Close bores (6EA/Arrows) by means of set screws.

※ Insert set screws with Loctite (Type No. 243).

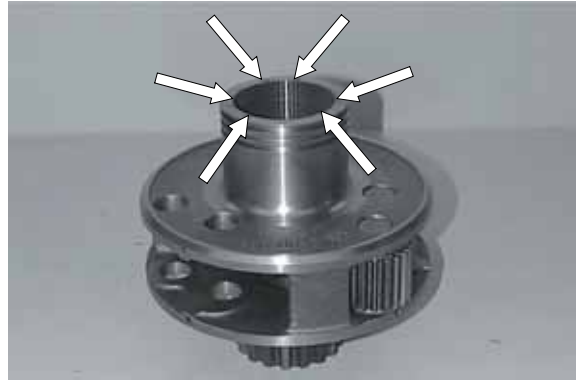

Figure 380

(2) Press needle sleeve in, with the reinforced shell facing the pressing-in tool until contact is obtained, and fix it by means of snap ring.

※ Special tool

Pressing-in sleeve 5870 506 131



Figure 381

(3) Press the ring in, with the great \varnothing showing downward, until contact is obtained.



Figure 382

(4) Introduce output shaft and install snap ring (Arrow).

Position sun gear, with the stepped plane face facing the snap ring, and introduce output shaft until the snap ring snaps into position.

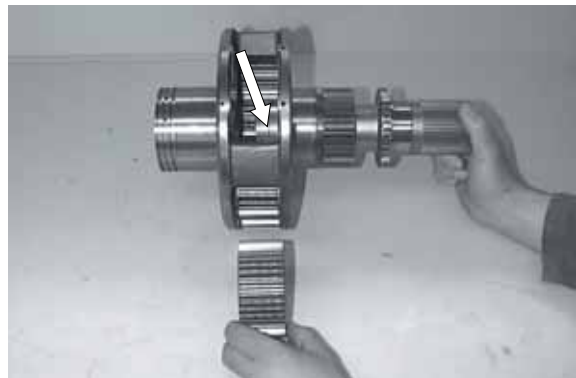

Figure 383

(5) Fix the sun gear by means of circlip.



Figure 384

(6) The Figure on the right shows the components of the planetary gear.

- 1 Thrust washer
- 2 Needle rollers(30 pieces)
- 3 Disk
- 4 Planetary shaft
- 5 Planetary gear

※ Install components 1 to 3.
As assembly aid, use grease.
Renew needle rollers only in sets.

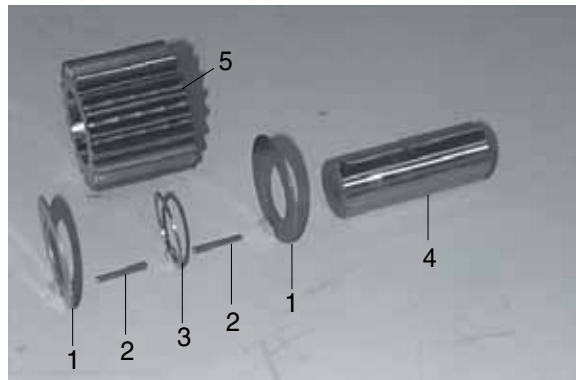

Figure 385

(7) Position planetary gear, align centrally and fix it by means of planetary shaft.

※ Pay attention to the installation position of the planetary shaft-central oil hole showing shead.

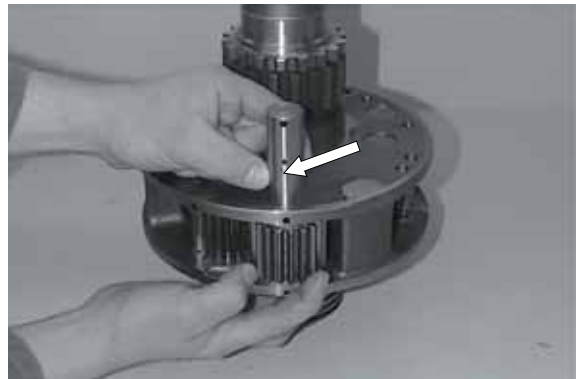

Figure 386

(8) Fix planetary shaft by means of roll pin.
Install the remaining planetary gears.

※ Drive the roll pins each time in up to the shaft center, see Arrow.

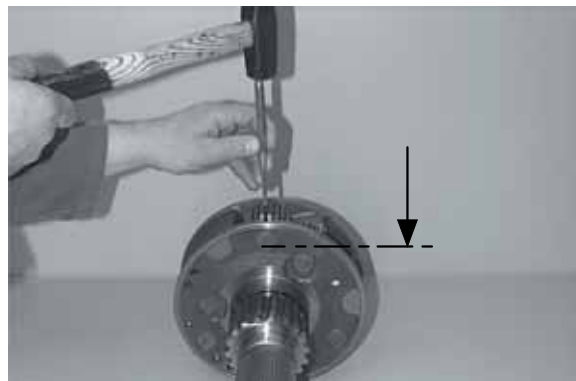

Figure 387

(9) Insert planet carrier into the internal gear.



Figure 388

(10) Insert bearing outer race (Arrow) into the internal gear carrier until contact is obtained.



Figure 389

(11) Supercool the internal gear carrier and position it against shoulder.

※ Use protective gloves.



Figure 390

(12) Fix internal gear carrier by means of snap ring.



Figure 391

(13) Heat bearing inner race and position it against shoulder.

※ Use protective gloves.



Figure 392

(14) Introduce output shaft.



Figure 393

(15) Fix output shaft by means of snap ring.



Figure 394

(16) Squeeze in and engage both rectangular rings (Arrows).



Figure 395

(17) Line up the bush(Arrow).

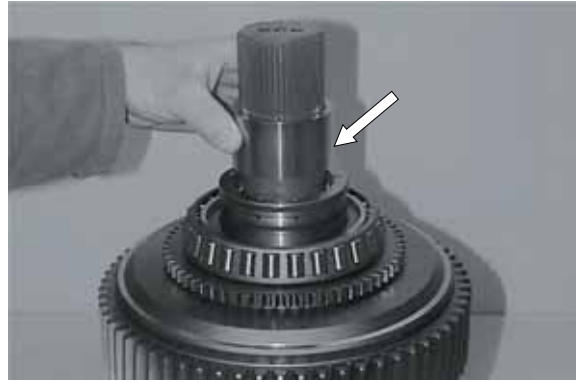

Figure 396

(18) Heat bearing inner race and position it against shoulder.

※ Use protective gloves.



Figure 397

(19) Insert plate.



Figure 398

(20) Lift the differential into the housing, using lifting device.

※ Special tool
Set of eye bolts 5870 204 002



Figure 399

(21) Position upper oil baffle and fasten both oil baffles by means of hexagon head screws (5EA) and hexagon nut (1EA).

※ Mount flat washers.

Secure hexagon head screws with Loctite (Type No. 243).

• Torque limit (M8/8.8):2.35kgf · m(17.0lbf · ft)



Figure 400

Preassemble and mount Housing cover

(1) Mount components.

1 Sealing cover(use Loctite Type No. 262)

2 Connecting piece(install new sealing ring)

3 Cover plate(install new gasket)

4 Sealing cover(use Loctite Type No. 262)

※ According to the transmission version, differences concerning components and their installation positions are possible.



Figure 401

(2) Drive the roll pin(2×8mm) flush-mounted in, see Arrow.

Equip screw plug with new O-ring and install it, see Arrow 2.



Figure 402

(3) Squeeze both snap rings(Arrow) into the recess.



Figure 403

- (4) Expand the two snap rings.
Introduce ball bearing, with the annular groove showing upward, until the upper snap ring snaps into the groove of the ball bearing

※ Special tool
Clamping Pliers 5870 900 026



Figure 404

- (5) Insert gear wheel until contact is obtained.

※ Special tool
Mallet 5870 280 004



Figure 405

- (6) Fix gear wheel by means of circlip.

※ Special tool
Set of external pliers 5870 900 015



Figure 406

Adjust Bearing preload of Differential bearing 0.0~0.1mm (Figure 407~409) :

- (7) Determine Dimension I from the mounting face to the locating face of the bearing outer race.

Dimension I e.g. 66.36mm



Figure 407

- (8) Mount bearing outer race.
Press bearing outer race uniformly on and determine Dimension II from bearing outer race to the mounting face.

Dimension II e.g. 64.00mm

- ※ Apply several measuring points and determine the average value.

- ※ Special tool

Straightedge 5870 200 022

Digital depth gauge 5870 200 072

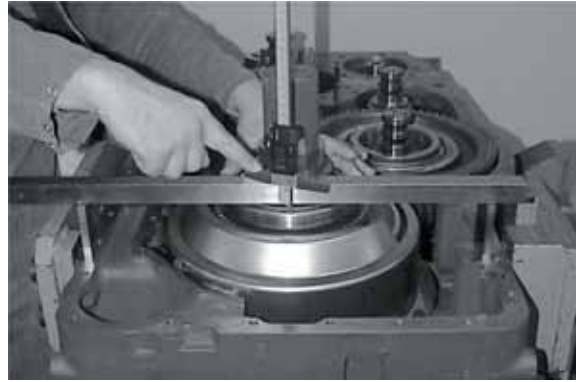

Figure 408

EXAMPLE E :

Dimension I e.g. 66.36mm

dimension II e.g. - 64.00mm

Difference 2.36mm

required Bearing preload e.g. + 0.04mm

gives Shim e.g. s = 2.40mm

- (9) Insert shim.



Figure 409

- (10) Install bearing outer race



Figure 410

- (11) Cover mounting face with sealing compound Loctite (Type No. 574).
Install two adjusting screws and position the housing cover on the gearbox housing until contact is obtained, using lifting device.

- ※ Special tool

Adjusting screws 5870 204 007

Lifting device 5870 281 055



Figure 411

- (12) Insert both cylindrical pins (Arrow 1 and 2) until contact is obtained.
 Fasten housing cover by means of screw connection.
 Drive roll pin (Arrow 3) flush-mounted in.
- Torque limit (M10/8.8): 4.70 kgf · m (33.9 lbf · ft)



Figure 412

- (13) Insert ball bearing until contact is obtained.



Figure 413

- (14) Introduce shim $s = 4.0\text{mm}$.



Figure 414

- (15) Fix ball bearing playfree, using shim and circlip.

- ※ Special tool
 Clamping pliers 5870 900 021



Figure 415

(16) Install shaft seal, with the sealing lip facing the oil chamber.

※ At application of the prescribed driver, the exact installation position is obtained.
Grease sealing lip.

※ According to the version, different shaft seals can have been applied.
Outer diameter rubber-coated-wet with spirit.

Outer diameter metallic-wet with sealing compound (Loctite, Type No. 574).

※ Special tool

Driver 5870 048 228



Figure 416

(17) Press screening plate against shoulder.

※ Special tool

Pressure piece 5870 506 126



Figure 417

(18) Line up output flange.

Wet contact face of the shim with sealing compound Loctite (Type No. 574) and fasten output flange with hexagon head screws.

• Torque limit(M10/8.8):4.70kgf · m(33.9lbf · ft)



Figure 418

(19) Fix hexagon head screws by means of lock plate.

※ Special tool

Driver 5870 057 009

Handle 5870 260 002



Figure 419

Adjust bearing preload-Clutch K3/K4 = 0.00~0.05mm (Figure 420~422) :

(20) Insert bearing inner race into the outer race.

Housing dimension :

Press the bearing inner race uniformly on, and determine Dimension I from the mounting face to the bearing inner race.

Dimension I e.g. 43.82mm

※ Apply several measuring points and determine the average value.



Figure 420

Cover dimension :

Determine Dimension II from the mounting face to the contact/bearing inner race.

※ Dimension II e.g. 42.15mm

Special tool

Straightedge 5870 200 022

Digital depth gauge 5870 200 072

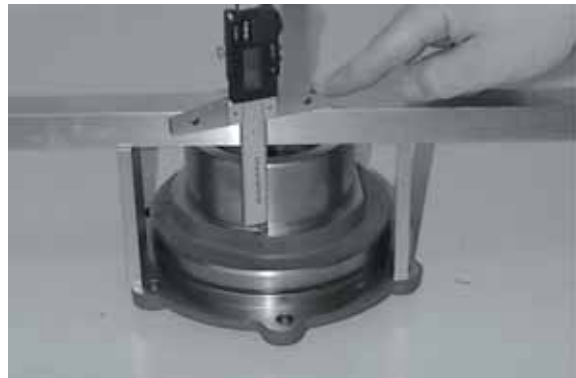

Figure 421

EXAMPLE F :

Dimension I e.g. 43.82mm

Dimension II e.g. - 42.15mm

Difference = 1.67mm

Bearing preload e.g. + 0.03mm

gives Shim(s) s = 1.70mm

(21) Line up the shim.



Figure 422

(22) Heat bearing inner race and position it against shoulder.

※ Use protective gloves.



Figure 423

- (23) Install and grease O-ring(Arrow).
Heat inner diameter of the bearing cover
(bearing seat).



Figure 424

- (24) Grease and align rectangular rings(3EA, Arrows) and align them centrally.



Figure 425

- (25) Install two adjusting screws.
Line up the bearing cover by means of
hexagon head screws and pull it uniformly
against shoulder.
- Torque limit(M10/8.8):4.70kgf · m(33.9lbf · ft)
- ※ Pay attention to the radial installation
position, see markings(Arrows).

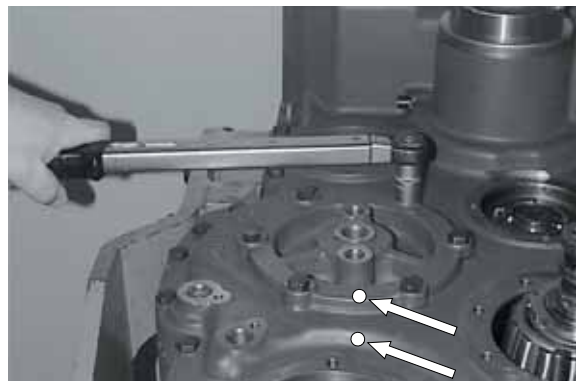

Figure 426

**Adjust bearing preload of Clutch KR/K2
= 0.00~0.05mm (Figure 427~430)**

- (26) Insert bearing outer race until contact is
obtained.



Figure 427

Housing dimension :

Determine Dimension I from bearing outer race to mounting face.

Dimension I e.g. 15.68mm

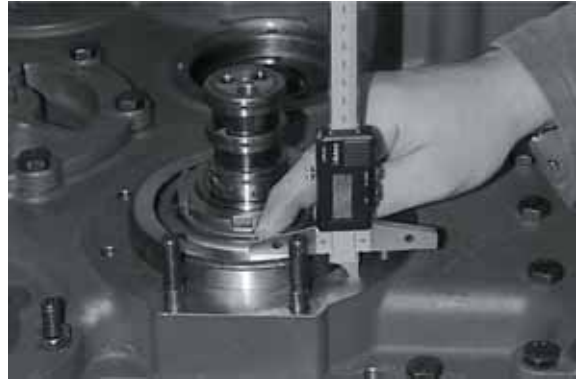

Figure 428

Cover dimension :

Determine Dimension II from the contact/bearing outer race to the mounting face.

Dimension II e.g. 17.46mm

※ Special tool
Digital depth gauge 5870 200 022



Figure 429

EXAMPLE G :

Dimension II e.g.	17.46mm
Dimension I e.g.	- 15.68mm
Difference	= 1.78mm
Bearing preload e.g.	+ 0.02mm
gives Shim(s)	s = 1.80mm

(27) Make shim adhere with assembly grease in the cover. Install O-ring (Arrow).



Figure 430

(28) Grease and align rectangular rings (Arrows) centrally.



Figure 431

EXAMPLE H :

Dimension I e.g.	52.67mm
Dimension II e.g.	- 50.75mm
Difference	= 1.92mm
Bearing preload e.g.	+ 0.03mm
gives Shim(s)	s = 1.95mm

(32) Insert shim.



Figure 436

(33) Insert bearing outer race until contact is obtained.
Line up O-ring (Arrow).



Figure 437

(34) Grease and align the rectangular rings (Arrow) centrally.



Figure 438

(35) Insert the bearing cover until contact is obtained and fasten by means of hexagon head screws.

· Torque limit(M10/8.8):4.70kgf · m(33.9lbf · ft)

※ Pay attention to the radial installation position, see markings (Arrows).

※ Special tool

Plastic mallet 5870 280 004

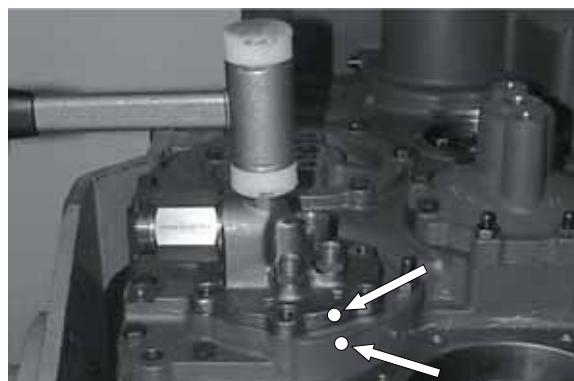

Figure 439

Install Countershaft axle

- (1) Tilt gearbox housing 180° .
Align countershaft gear centrally.
Install adjusting screw (Figure 440).

※ Special tool
Adjusting screws 5870 204 022



Figure 440

- (2) Supercool pin.
Make determined shim (see page 3-181)
adhere with grease.



Figure 441

- (3) Insert pin until contact is obtained.
※ Use protective gloves.



Figure 442

- (4) Remove adjusting screw and fix bolt by means of hexagon head screw.
 - Torque limit(M10/8.8):4.70kgf · m(33.9lbf · ft)※ Wet thread of hexagon head screw with Loctite (Type No. 243).



Figure 443

- (5) Drive the sealing covers(Arrows) in, with the concave side showing downward, flush-mounted to the housing face.

※ Wet contact face with Loctite (Type No. 262).

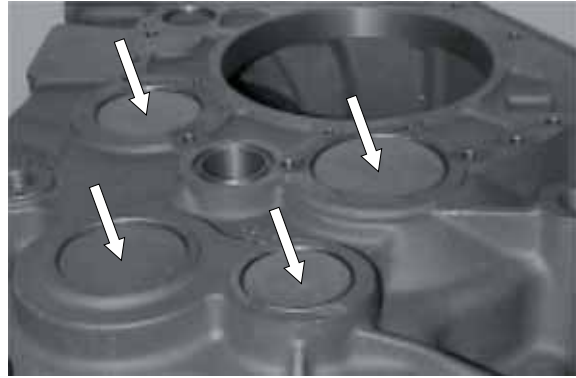

Figure 444

Install Emergency steering pump

- (1) Tilt gearbox housing 180° .
Insert O-ring(Arrow) into the annular groove and grease it.



Figure 445

- (2) Introduce emergency steering pump until contact is obtained and fasten it by means of hexagon head screws.

· Torque limit(M10/8.8):2.35kgf · m(17.0lbf · ft)

※ Wet thread of hexagon head screw with Loctite (Type No. 262).



Figure 446

Hydraulic pump

- (1) Press needle sleeve(Arrow) against shoulder, with the reinforced shell facing the pressing-in tool.

※ Special tool
Pressing-in tool 5870 058 041



Figure 447

- (2) Insert disk $s = 1.3\text{mm}$ and position bearing outer race against shoulder.



Figure 448

- (3) Install and grease O-ring (Arrow).



Figure 449

- (4) Supercool the pump to about -80°C .
Install two adjusting screws and introduce pump until contact is obtained.

※ Pay attention to the radial installation position.

※ Use Protective gloves.

※ Special tool

Adjusting screws 5870 204 021



Figure 450

- (5) Install O-ring (Arrow) and mount pump flange.

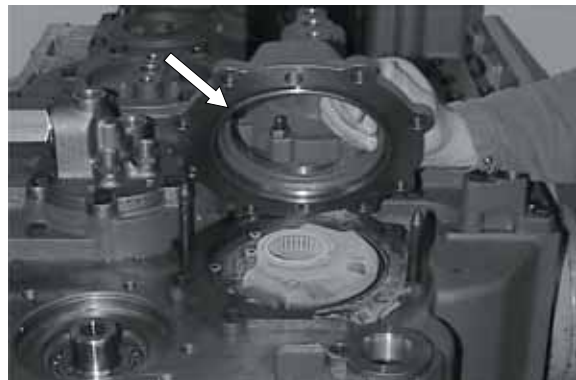

Figure 451

(6) Fasten pump flange, respective the pump by means of hexagon head screws.

- Torque limit(M12/8.8):8.06kgf · m(58.3lbf · ft)

- ※ Wet thread of the two hexagon head screws, (Position, see Arrows) with Loctite (Type No. 243) (through holes).

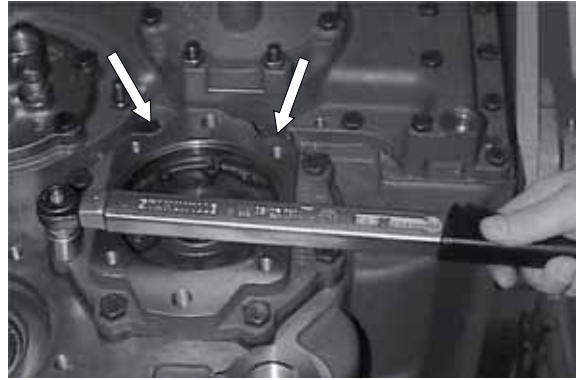

Figure 452

(7) Insert O-ring(Arrow) into the annular groove and grease it. Fasten pump flange (Power take-off) with hexagon head screws.

- Torque limit(M14/8.8):12.7kgf · m(92.2lbf · ft)



Figure 453

Axle disconnection

- (1) Insert ball bearing until contact is obtained.



Figure 460

- (2) Adjust ball bearing by means of disk s = 4.0mm, shim(optional) and circlip playfree.



Figure 461

- (3) Position compression spring, piston and shift fork.

- ※ Stop screw as well as rectangular ring will be installed later.



Figure 462

- (4) Introduce pin until contact is obtained and fix it by means of circlip.
Now, close bore with cover.

- ※ Pay attention to the installation position of the pin-thread for extraction is showing outward.
Wet contact face of the sealing cover with Loctite (Type No. 262).



Figure 463

- (5) Insert disk, with the chamfer(Arrow) showing upward.



Figure 464

- (6) Preload compression spring, install sliding blocks and sliding sleeve.

- ※ Pay attention to the sliding sleeve great chamfer on the outer diameter showing downward.



Figure 465

Adjust Shifting travel by means of Measuring device (Figure 466~470):

- (7) Insert stop screw into the measuring device.

- ※ Special tool
Measuring device 5870 200 107



Figure 466

- (8) Line up measuring device and position it on the mounting face until contact is obtained.

- ※ Special tool
Measuring device 5870 200 107



Figure 467

(9) Determine Dimension I, see Figure on the right.

Dimension I e.g. 32.90mm

※ Special tool

Digital Depth gauge 5870 200 072

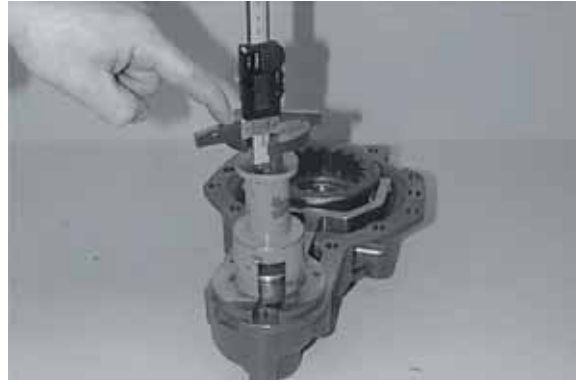

Figure 468

(10) Mount flat gasket and determine Dimension II from the mounting face to the bore root (stop face/socket head screw).

Dimension II e.g. 34.50mm



Figure 469

EXAMPLE I :

Dimension II e.g. 34.50mm

Dimension I e.g. - 32.90mm

Difference = 1.60mm

Adjusting dimension + 1.00mm

gives Shim(s) s = 2.60mm

※ Adjusting dimension = 1.0mm, gives the required shifting travel.

(11) Line up shim(s) $s = 2.6\text{mm}$ (Arrow) and install socket head screw.

※ Wet thread of socket head screw with Loctite (Type No. 243).

· Torque limit(M10/8.8):4.70kgf · m(33.9lbf · ft)

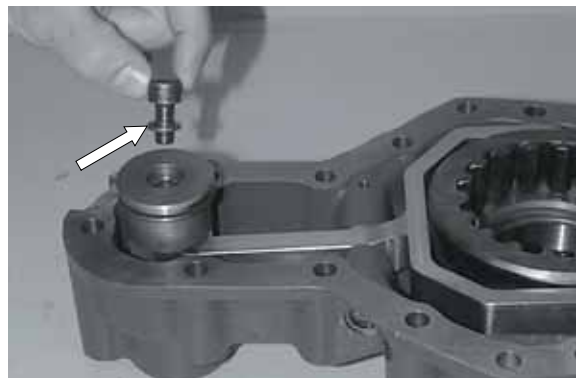

Figure 470

(12) Line up rectangular ring(VITON) into the ring groove of the piston (Arrow) and oil it.

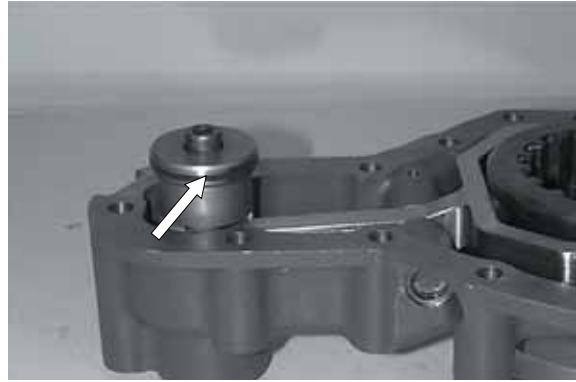

Figure 471

(13) Install switch :

- 1 Lock
- 2 Sealing ring (s=1.5mm)
- 3 Switch

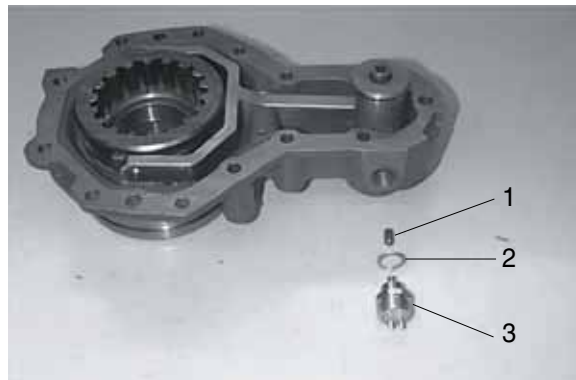

Figure 472

(14) Install two adjusting screws and mount flat gasket.

Heat ball bearing, introduce axle disconnection device carefully and position it uniformly against shoulder, using hexagon head screws and socket head screws.

- ※ Special tool
- Adjusting screws 5870 204 007



Figure 473

(15) Insert both socket head screws(Arrows) until contact is obtained.

Tighten hexagon head screws and socket head screws.

- Torque limit(M10/8.8):4.70kgf · m(33.9lbf · ft)

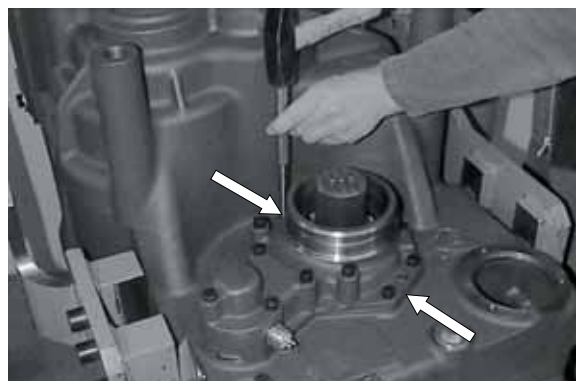

Figure 474

(16) Insert perforated plate(1) and filter insert(2) into the housing bore(Arrow/ Figure 476).

Close bore, till the assembly of the hydraulic oil feed, by means of plug(3).

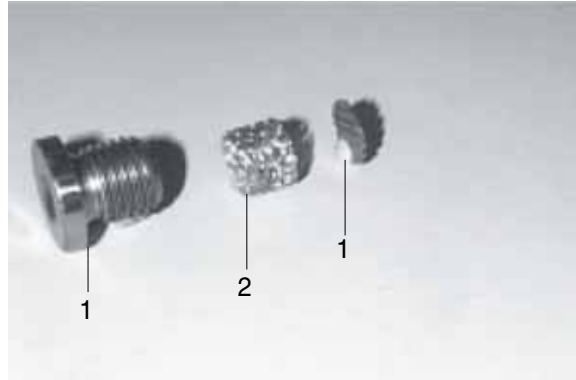

Figure 475

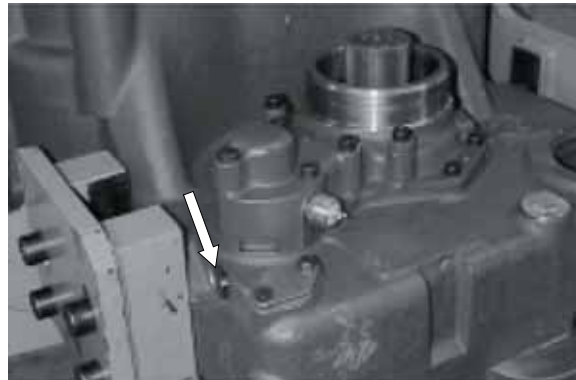

Figure 476

(17) Install shaft seal (Arrow), with the sealing lip facing the oil chamber.

※ At application of the prescribed driver(s), the exact installation position is obtained.
Grease sealing lip.

▲ Outer diameter rubber-coated : wet with sprit.
Outer diameter metallic : wet with sealing compound loctite(Type No. 574).

※ Special tool

Driver 5870 048 228

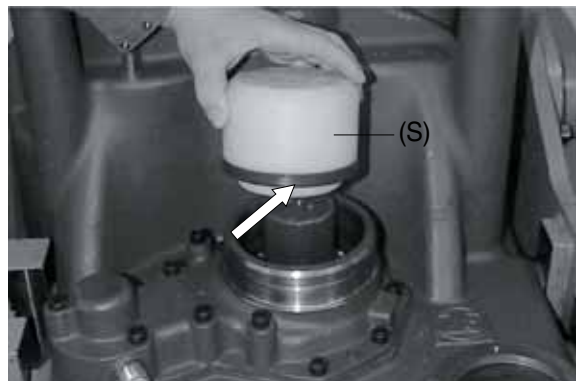

Figure 477

(18) Press screening plate(Arrow) against shoulder.

- ※ Special tool
Pressure piece. 5870 506 126



Figure 478

(19) Line up output flange.

Wet contact face of the disk with sealing compound Loctite(Type No. 574) and fasten output flange with hexagon head screws.

- Torque limit(M10/8.8):4.70kgf · m(33.9lbf · ft)



Figure 479

(20) Fix hexagon head screws by means of lock plate.

- ※ Special tool
Drive 5870 057 009
Handle 5870 260 002



Figure 480

Filter

(6) Introduce filter into the housing bore.

- ※ Oil sealing ring (Arrow).



Figure 481

(2) Fasten cover by means of hexagon head screws (mount flat washers).

※ Install new O-ring (Arrow).

- Torque limit(M8/8.8):2.35kgf · m(16.7lbf · ft)

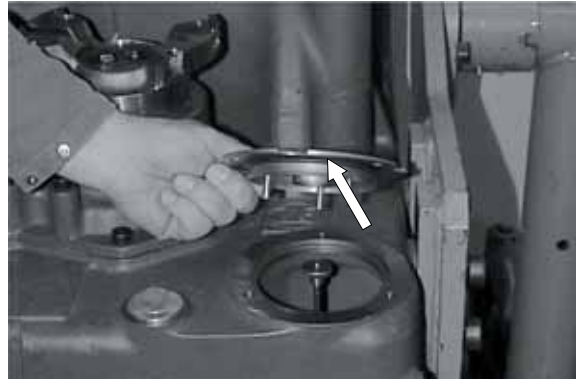

Figure 482

(3) Equip screw plugs(1 and 2) with new O-ring and install them.

Mount gasket and fasten cover plate(3) by means of hexagon head screws.

- Torque limit(screw plugs):14.3kgf · m
(103lbf · ft)
- Torque limit(M8/8.8):2.35kgf · m(17.0lbf · ft)

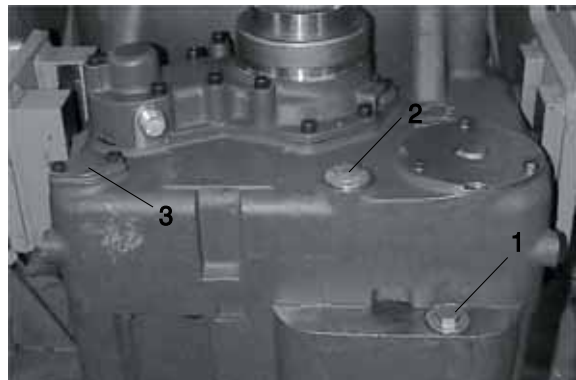

Figure 483

Input shaft (Power take-off-Pump)

(1) Tilt gearbox housing 180° .

Squeeze V-rings(3EA) into the recess of the driver(internal splines).

Install fitting key(Arrow).



Figure 484

Adjust gap dimension = 0.50mm
(Driver/Input shaft) (Figure 485~489) :

1 Driver

2 Input shaft

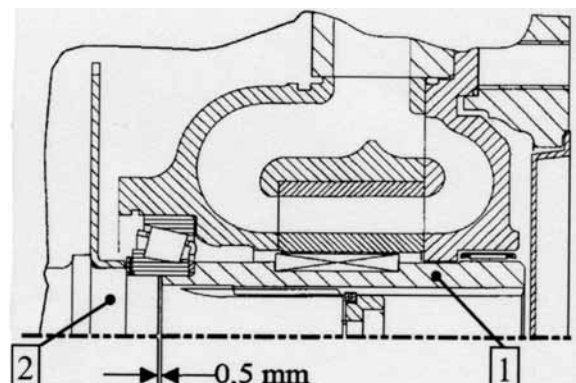

Figure 485

- (2) Line up the disk $s = 1.90\text{mm}$ and position bearing inner race against shoulder.



Figure 486

- (3) Determine Dimension I from the bearing inner race to the end face/driver.

Dimension I e.g. 9.64mm



Figure 487

- (4) Determine Dimension II (A-B).

Dimension II e.g. 10.64mm

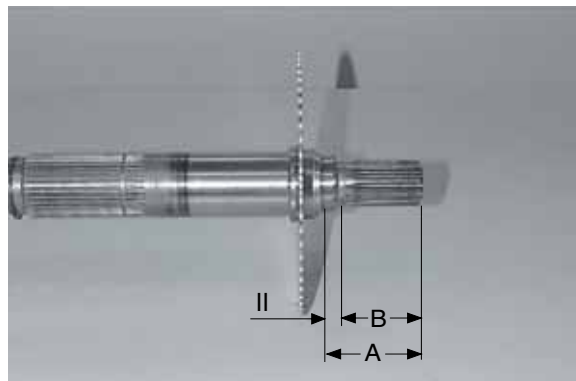

Figure 488

EXAMPLE J

Dimension II e.g.		10.64mm
Dimension I e.g.	-	9.64mm
Difference	=	1.00mm
Required gap dimension	+	0.50mm
gives Shim(s)	s =	1.50mm

(5) Line up shim(s).

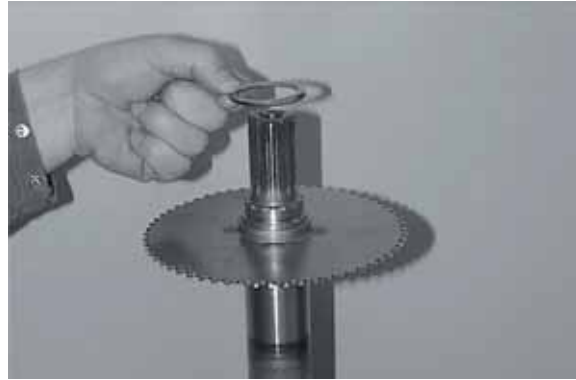

Figure 489

(6) Position driver against shoulder and fix it by means of clamping disk and socket head screw.

- Torque limit(M10/8.8):3.26kgf · m(23.6lbf · ft)



Figure 490

(7) Press bearing inner race against shoulder.



Figure 491

(8) Squeeze circlip in(Arrow) and line up the drive gear.

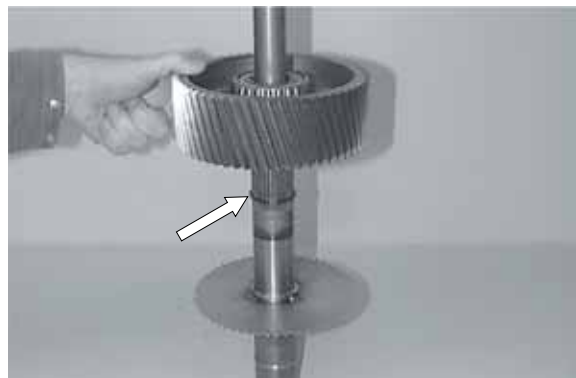

Figure 492

(9) Squeeze circlip in(Arrow) and engage it.

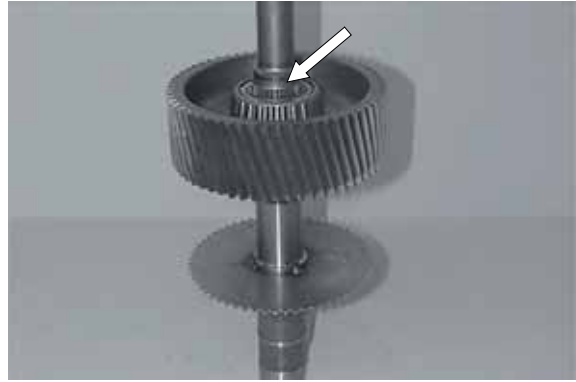

Figure 493

(10) Introduce preassembled input shaft until contact is obtained.

- ※ Pay attention to the overlapping of the fitting key with the fitting key groove.



Figure 494

Adjust axial play of the Input shaft bearing = 0.0~0.05mm (Figure 495~497):

(11) Mount flat gasket.

Mount bearing outer race, press it uniformly on and determine Dimension I from the mounting face(gasket) to the bearing outer race.

Dimension I e.g. 128.50mm

- ※ Apply several measuring points and determine the average value.



Figure 495

(12) Measure Dimension II from the mounting face/converter bell to the locating face/bearing outer race.

Dimension II e.g. 127.46mm

- ※ Special tool
Straightedge 5870 200 022
Gauge blocks 5870 200 080



Figure 496

EXAMPLE K :

Dimension I e.g.	128.50mm
Dimension II e.g.	- 127.46mm
Difference	= 1.04mm
Axial play e.g.	- 0.04mm
gives Shim(s)	s = 1.00mm

- (13) Insert shim and position bearing outer race until contact is obtained.



Figure 497

Input - Converter bell

- (1) Insert bearing outer race into the housing bore until contact is obtained and install bearing inner race, see Arrow.



Figure 498

- (2) Introduce spur gear (Arrow). starting from the side, with the long collar showing upward, and bring it in position.



Figure 499

- (3) Insert both roll pins ($\varnothing 2.5$ and $\varnothing 1.5$ mm) flush-mounted into the bore (Arrow) of the input shaft.



Figure 500

(4) Supercool the input shaft and introduce it until contact is obtained.

※ Use protective gloves.



Figure 501

(5) Heat bearing inner race and line it up until contact is obtained.

※ Use protective gloves.



Figure 502

(6) Position bearing outer race against shoulder.



Figure 503

Adjust Axial play of the Drive gear bearing = 0.03 ~ 0.07mm (Figure 504 ~ Example):

(7) Measure Dimension I from the mounting face to the bearing outer race.

Dimension I e.g. 59.60mm

※ Special tool

Straightedge 5870 200 022

Digital Depth gauge 5870 200 072



Figure 504

- (8) Mount gasket(Arrow) and determine Dimension II from the mounting face to the locating face of the bearing outer race.

Dimension II e.g. 58.50mm

EXAMPLE K :

Dimension I e.g. 59.60mm

Dimension II e.g. - 58.50mm

Difference = 1.10mm

Axial play e.g. - 0.05mm

gives Shim(s) s = 1.05mm

- ※ Assembly of the shim, see Figure 508.

- ※ Special tool

Gauge blocks 5870 200 067

Straightedge 5870 200 022

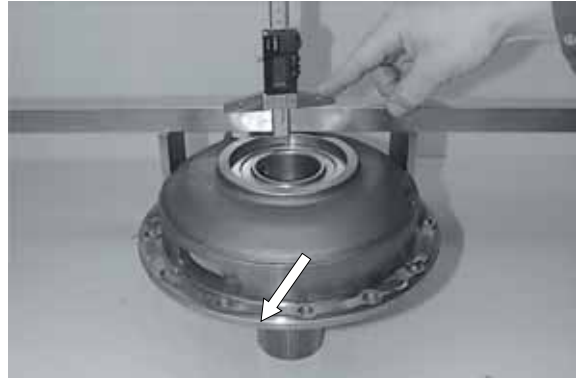

Figure 505

- (9) Insert needle sleeve(Arrow), with the reinforced shell facing the pressing-in tool until contact is obtained.

- ※ Special tool

Driver 5870 058 051

Handle 5870 260 002



Figure 506

- (10) Install two adjusting screws and mount gasket (Arrow 1).

Install converter safety valve(disk, compression spring and ball), see Arrow 2.

Squeeze both rectangular rings into the annular grooves of the input shaft and engage them (Arrow3).

Now, grease rectangular rings and align them centrally.



Figure 507

- ※ Special tool

Adjusting screws 5870 204 007

- (11) Supercool oil feed flange, (about -80°C) and make shim $s= 1.05\text{mm}$ (see page 3-197) adhere with assembly grease in the bearing bore.



Figure 508

- (12) Introduce supercoiled oil feed flange until contact is obtained.

- ※ Pay attention to the radial installation position.
- ※ Use protective gloves.



Figure 509

- (13) Mount flat gasket (Arrow) and install bearing cover.

- ※ Pay attention to the radial installation position.
- Torque limit(M10/8.8): $4.70\text{kgf} \cdot \text{m}$ ($33.9\text{lb} \cdot \text{ft}$)



Figure 510

- (14) Wet thread of the screw-in sleeves (1 and 2) with Loctite (Type No. 262) and install the two screw-in sleeves. Equip screw plugs(3 and 4) with new O-rings and install them.

- Torque limit(10×1): $2.55\text{kgf} \cdot \text{m}$ ($18.4\text{lb} \cdot \text{ft}$)
- Torque limit(M14 \times 1.5): $3.57\text{kgf} \cdot \text{m}$ ($25.8\text{lb} \cdot \text{ft}$)

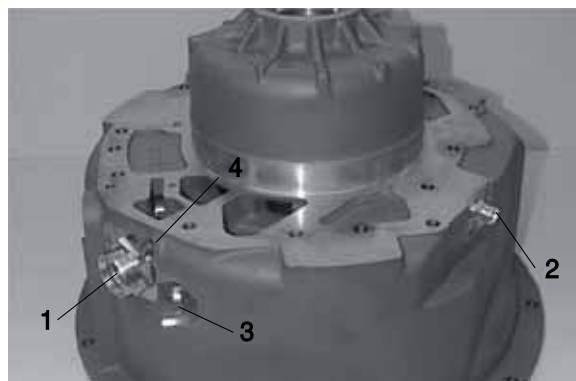

Figure 511

**Converter pressure back-up valve
(Figure 512 and 513):**

- (15) Drive roll pin (6×50mm) into the bore until contact is obtained.



Figure 512

- (16) Introduce spool and compression spring.
Equip screw plug with new O-ring and install it.

- Torque limit : 13.3kgf · m(95.9lbf · ft)

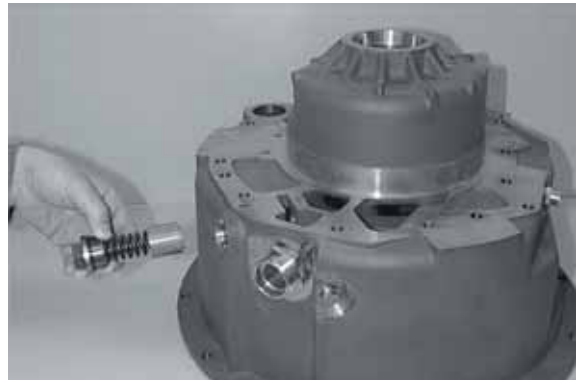

Figure 513

- (17) Remove input shaft and heat housing bore (about 120°C) .

- ※ Carry out the following steps(Figure 515~517) in immediate chronological order.

- ※ Special tool

Preheating sleeve	5870 801 003
Hot-air blower 220V	5870 221 500
Hot-air blower 110V	5870 221 501



Figure 514

- (18) Grease rectangular ring(Arrow) and align it centrally. Introduce input shaft until contact is obtained.

- ※ Pay attention to the overlapping of the fitting key with the fitting key groove.



Figure 515

(19) Install two adjusting screws and mount flat gasket (Arrow 1).
Lay O-ring (Arrow 2) into the annular groove.

- ※ Special tool
Adjusting screws 5870 204 021

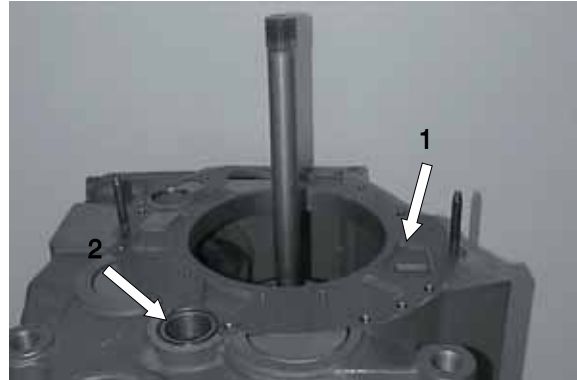

Figure 516

(20) Introduce converter bell by means of lifting device until contact is obtained.

- ※ Slight rotary motions of the input shaft will facilitate the sliding in.
Protect the splines from damage.
Pay attention to the radial installation position.

- ※ Special tool
Lifting device 5870 281 047
Set of eye bolts 5870 204 002



Figure 517

(21) Fasten converter bell by means of hex head screws.

- Torque limit(M8/10.9):3.47kgf · m(25.1lbf · ft)
- Torque limit(M12/10.9):11.7kgf · m(84.8lbf · ft)



Figure 518

(22) Insert O-ring (Arrow) into the annular groove of the converter bell.



Figure 519

(23) Grease rectangular ring (Arrow) and align it centrally.



Figure 520

(24) Introduce retarder along with converter against shoulder, using lifting device and fasten it by means of head screws.

※ Pay attention to the radial installation position. Binding are the Specifications of the Vehicle Manufacturer, respective the markings applied at the disassembly.

※ Special tool

Lifting device 5870 281 047

Set of eye bolts 5870 204 002



Figure 521

(25) Tilt transmission 90°.

Insert pot flush-mounted to the housing face.

※ Wet sealing surface with Loctite (Type No. 262).



Figure 522

(26) Install breather (Arrow).



Figure 523

- (27) Equip screw plug(Arrow 1) with new O-ring and install it.
Install the two retaining plates(Arrows 2).

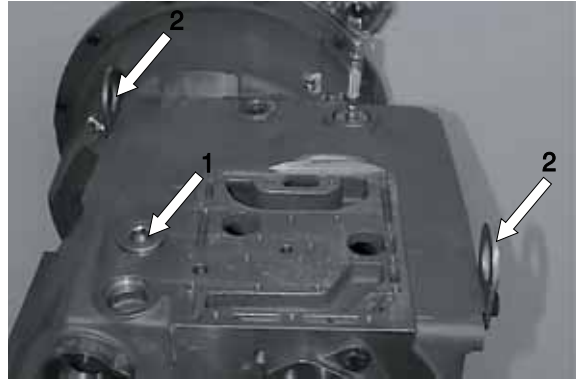

Figure 524

- (28) Mount hydraulic control unit.

Install all oil lines.

- ※ The line routing is different according to the design. In this connection, pay attention to the Perspective Illustrations of the corresponding Spare Parts List.

Inductive transmitters and Speed sensor

- (1) The following drafts are showing the installation position of the single inductive transmitters and the speed sensor.

6 Inductive transmitter	n-Turbine
14 Inductive transmitter	n-Engine
39 Inductive transmitter	n-Central gear train
31 Speed sensor	n-Output and Speedometer

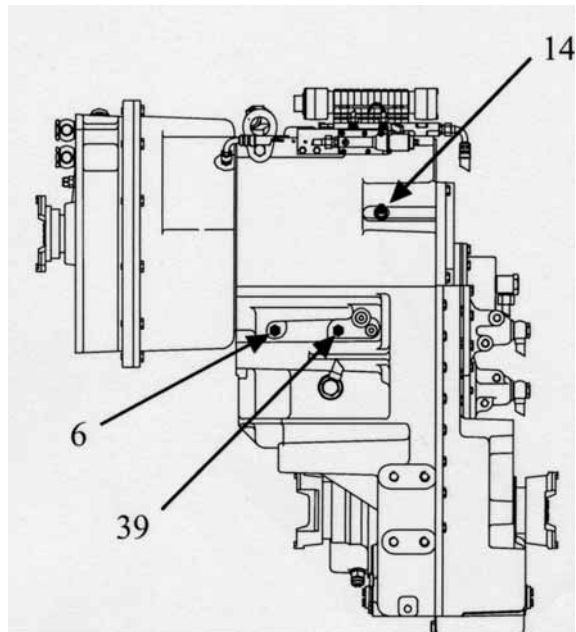

Figure 528

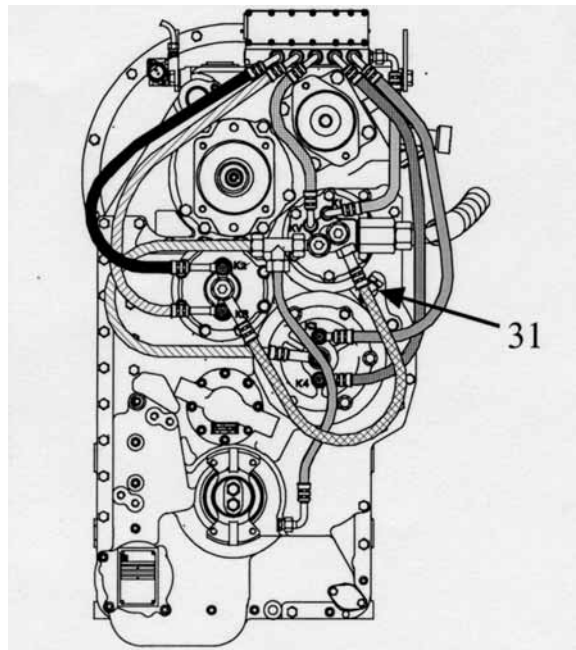

Figure 529

- ※ The following Figures describe the assembly, respective setting of the inductive transmitter n-Engine(14).

The assembly of the inductive transmitter n-Turbine(6) and n-Central gear train(39) has to be carried out accordingly.

- ※ Pay attention to the different Setting dimensions **X**.

Inductive transmitter n-Engine(14)

$$X = 0.5^{+0.3} \text{mm}$$

Inductive transmitter n-Turbine (6)

$$X = 0.5^{+0.3} \text{mm}$$

Inductive transmitter n-Centr.gear train(39)

$$X = 0.3 \pm 0.1 \text{ mm}$$

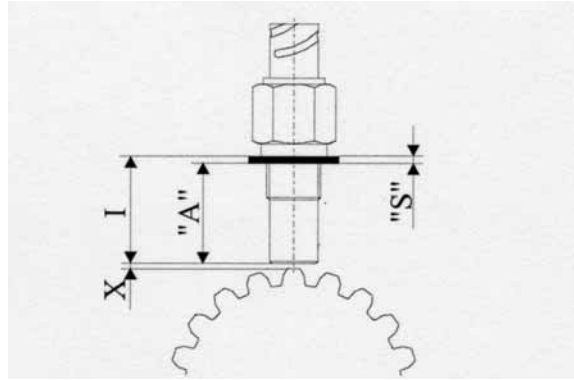

Figure 530

Set Dimension X by means of adjusting disk(s)(Figure 531~536):

- (2) Measure Dimension I from the contact face to the screw-in face on the inductive transmitter.

Dimension I e.g. 30.00mm



Figure 531

- (3) Rotate counting disk radially until one **tooth tip is central to the inductive transmitter bore.**

Screw the plug gauge in until contact is obtained.

Position anvil on the tooth tip until contact is obtained and lock it by means of set screw (Figure 532 and 533).

- ※ Special tool

Plug gauge 5870 200 104



Figure 532

- ※ Special tool
Plug gauge 5870 200 104

Figure 533

- (4) Screw the plug gauge out and determine Dimension II (see also Figure 533).

Dimension II e.g. 30.10mm



Figure 534

EXAMPLE M1

Dimension II e.g. 30.10mm
 Dimension X (0.5^{+0.03}mm) e.g. - 0.60mm
gives installation dimension A $s = 29.50\text{mm}$

EXAMPLE M2 :

Dimension I e.g. 30.00mm
 Installation dimension A e.g. - 29.50mm
gives adjusting disk(s) $s = 0.50\text{mm}$

- (5) Line up the corresponding adjusting disk(s) and wet thread(Arrow) with Loctite(Type No. 574).



Figure 535

(6) Install inductive transmitter n-Engine(14), see Arrow.

· Torque limit : 3.06kgf · m(22.1lbf · ft)

※ Set and install the inductive transmitter n-Turbine(6) and n-Central gear train (39) accordingly.

Pay attention to the different setting dimension.

Installation position of the single inductive transmitters.



Figure 536

Install Speed sensor n-Output/Speedometer(31) (Figure 540~545):

※ Setting dimension $X = 1.0^{+0.5}mm$

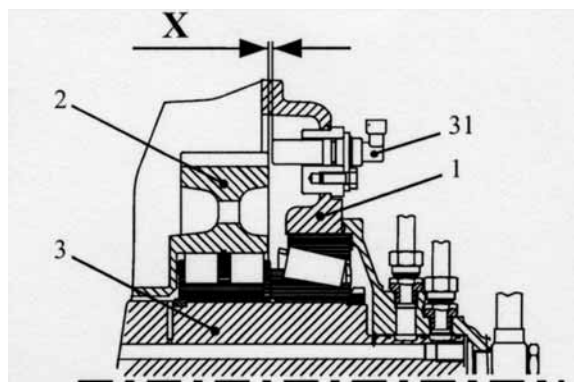

Figure 540

(7) The Figure on the right shows the speed sensor (Hall sensor).

1 Speed sensor

2 O-ring

3 Setting plate(s)



Figure 541

(8) Determine Dimension I from the housing face to the spur gear K3.

Dimension I e.g. 39.20mm



Figure 542

(9) Measure Dimension II from the contact face to the mounting face.

Dimension II e.g. 39.00mm

- ※ Special tool
Digital Depth gauge 5870 200 072



Figure 543

EXAMPLE N1

Dimension I e.g. 39.20mm

Dimension X ($1.0^{+0.5}$ mm) e.g. - 1.20mm

gives Installation s = 38.00mm dimension

EXAMPLE N2

Dimension II e.g. 39.00mm

Installation dimension A e.g. - 38.00mm

gives Setting plate(s) s = 1.00mm

Line up setting plates (2EA, $s = 0.5$ mm) and grease O-ring.



Figure 544

Fasten speed sensor by means of socket head screw.

- Torque limit(M8/8.8) : 2.35kgf · m(17.0lbf · ft)
- ※ Installation position of the speed sensor.
- ※ Prior to the commissioning of the Transmission, carry out the oil filling according to the Operating Instructions.



Figure 545

3. AXLE

1) FINAL DRIVE

(1) DISASSEMBLY

- ① Loosen oil drain plug and drain oil.

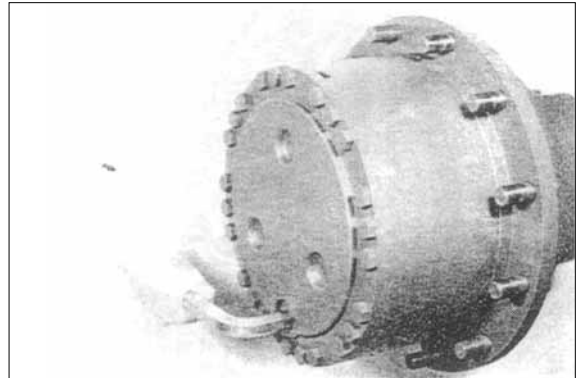

AX002

- ② Loosen hexagon head screws and lift off the planetary carrier.

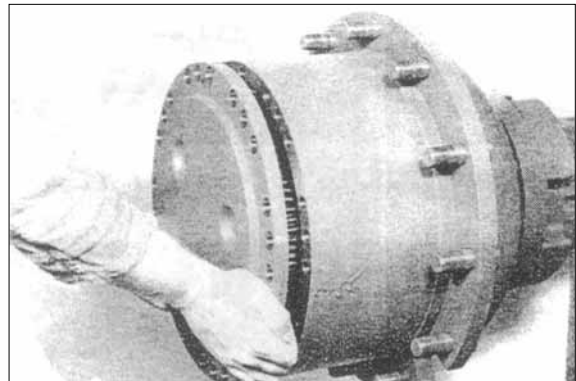

AX003

- ③ Squeeze out circlip and pull off the planetary gears.
Remove thrust washer.

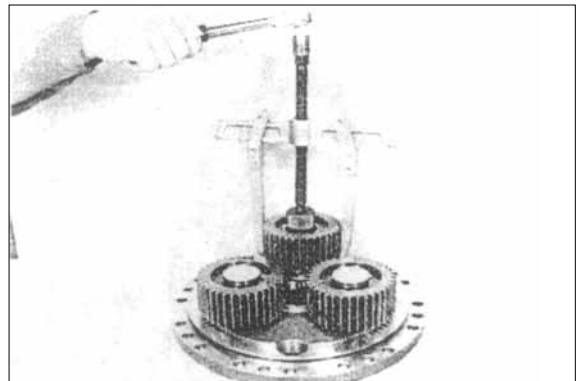

AX004

- ④ Pull sun gear along with inner plate carrier from the stub shaft, respectively out of the plate pack.

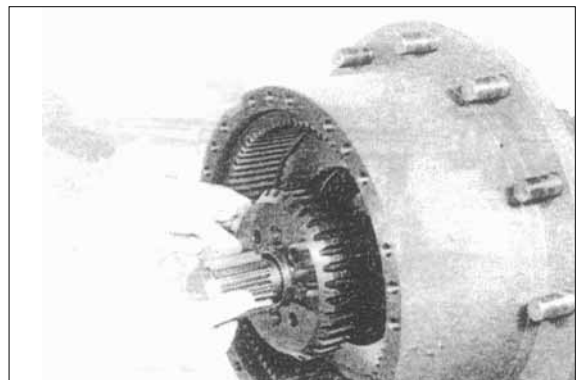

AX005

- ⑤ Loosen locking screws and remove ring from the inner plate carrier.

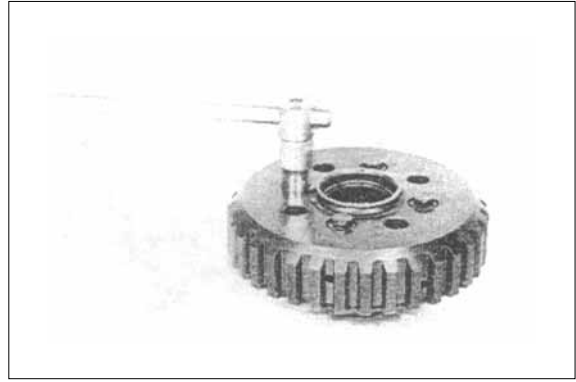

AX006

- ⑥ Squeeze out circlip.

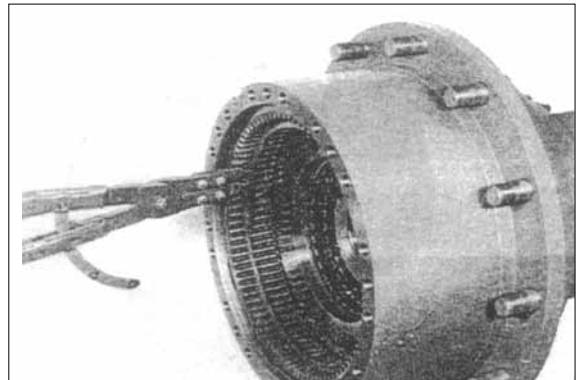

AX007

- ⑦ Remove backing plate and plate pack.



AX008

- ⑧ Remove thrust washer.

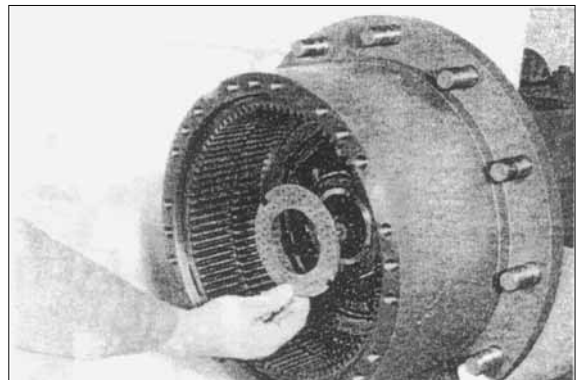

AX009

⑨ Remove lock plate.

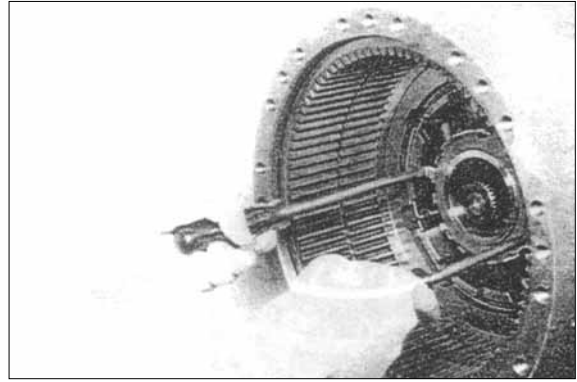

AX010

⑩ Loosen and remove slotted nut.

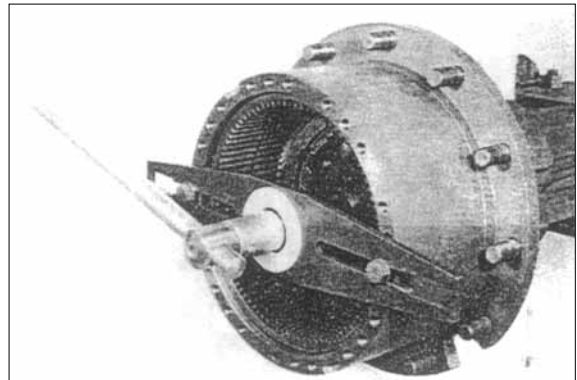

AX011

⑪ Pull stub shaft out of the axle housing.

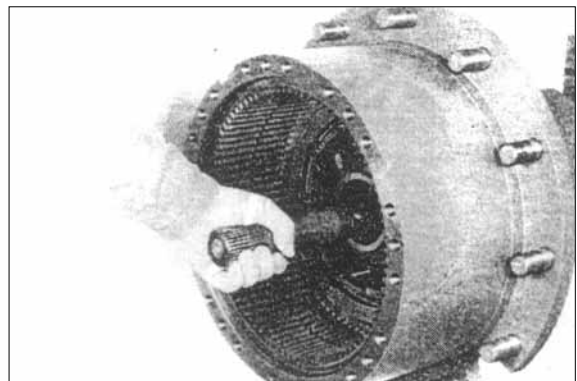

AX012

⑫ Separate complete hub from hub carrier.

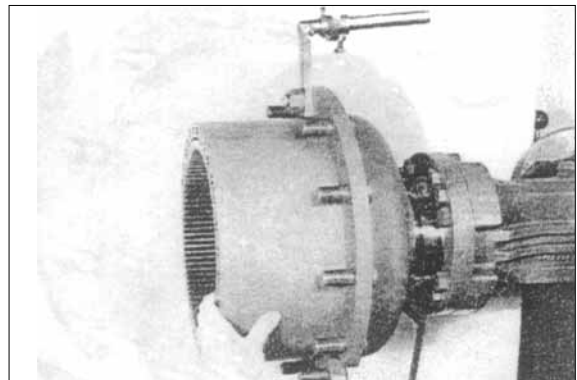

AX013

- ⑬ Lift internal gear and internal gear carrier out of the hub.
Remove released spacer.

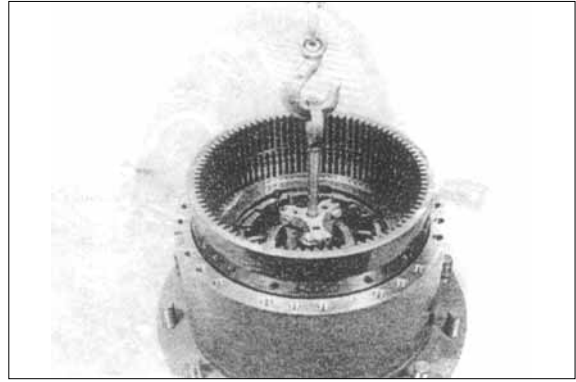

AX014

- ⑭ Unhook return springs.

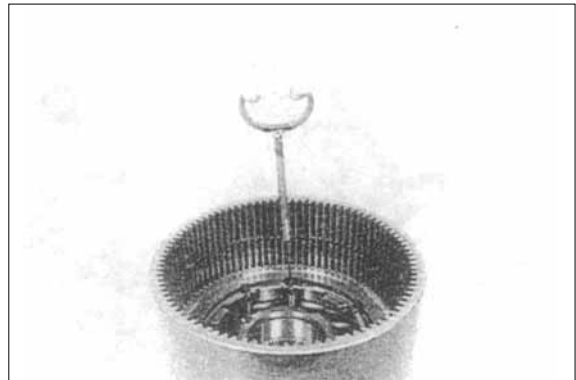

AX015

- ⑮ Take out the piston and remove sealing components.

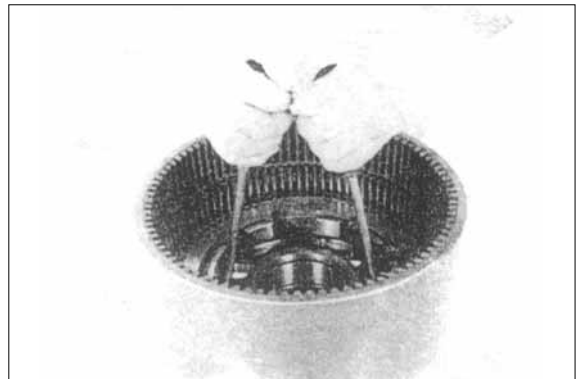

AX016

Pull off tapered roller bearing from the internal gear carrier.

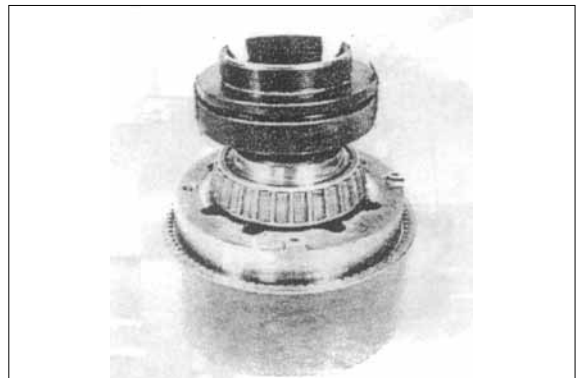

AX017

Pry shaft seal out of the hub and remove the bearing inner race.

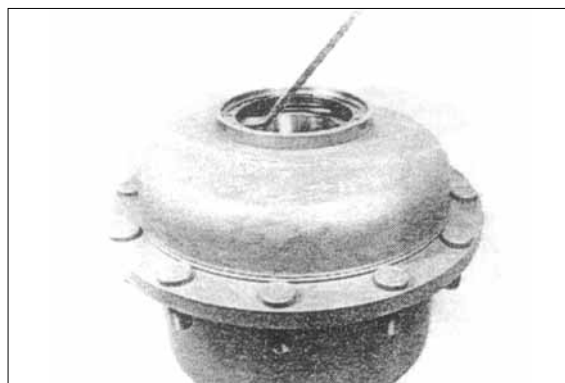

AX018

If required drive out and remove the two bearing outer races.



AX019

Remove bleeder valve.

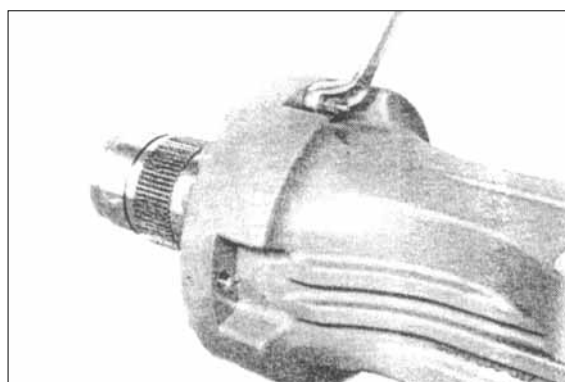

AX020

Loosen hexagon head screws and separate the hub carrier from the axle housing.

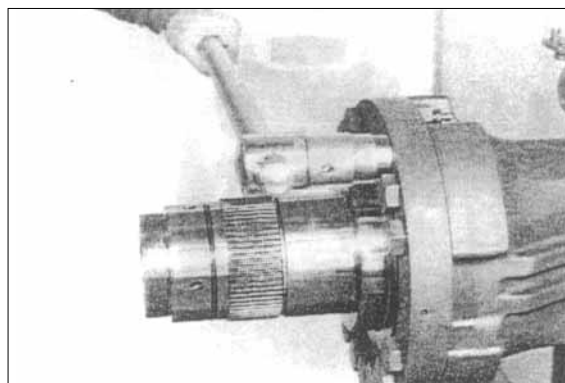

AX021

(2) ASSEMBLY

Hub carrier

- ① Fasten hub carrier on the axle housing by means of hexagon head screws.
 - ※ Pay attention to the installation position. Cover flange-mounted surface with sealing compound.

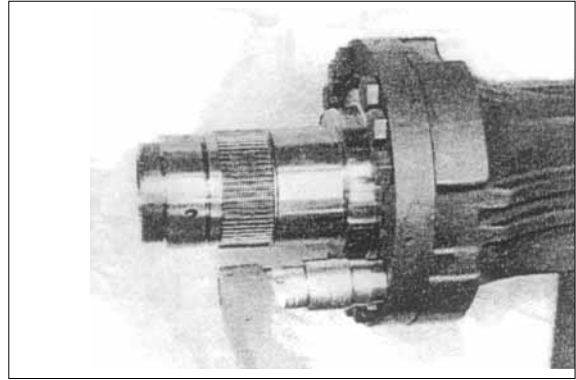

AX022

- ② Pull the wheel studs into the hub bores, using a special device.

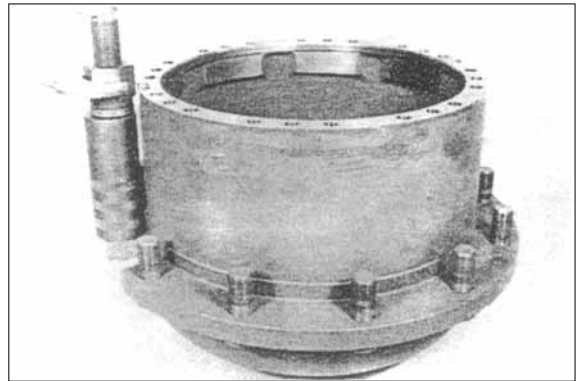

AX023

- ③ Drive both bearing outer races firmly against shoulder.



AX024

- ④ Guide the bearing inner race over the end of the hub carrier until contact is obtained.

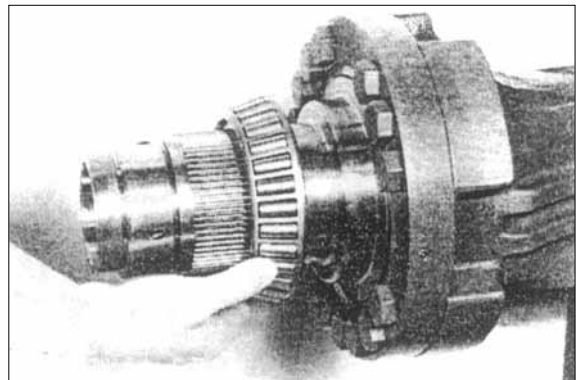

AX025

- ⑤ Guide hub over the end of the hub carrier.

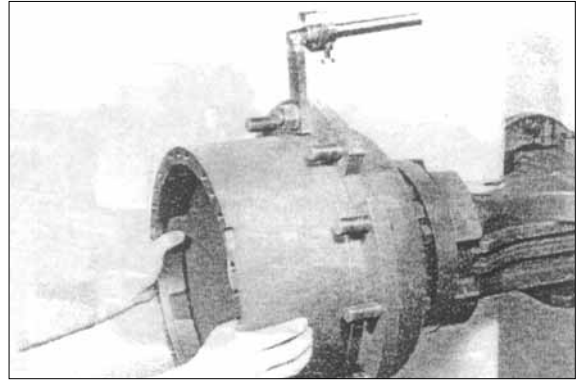

AX026

- ⑥ Heat bearing inner race and place it firmly against shoulder.



AX027

- ⑦ Assemble spacer $s=5.4\text{mm}$ (Empirical value).

- ※ If hub carrier, hub as well as internal gear carrier are not renewed we recommend to install the existing spacer again. Decisive, however, is the rolling resistance of the wheel bearing, see figure ⑩, page 3-220.

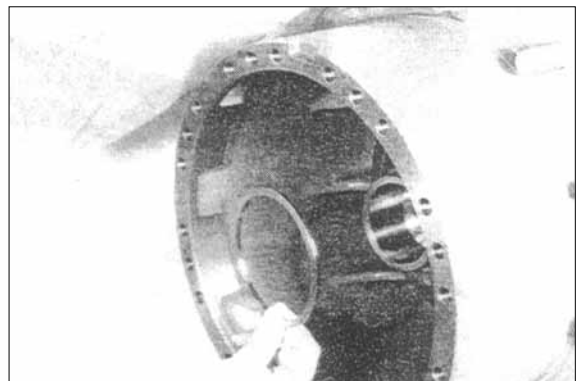

AX028

- ⑧ Screw installer over the threads of the hub carrier.

Guide complete internal gear over the hub carrier splines and fix the hub.

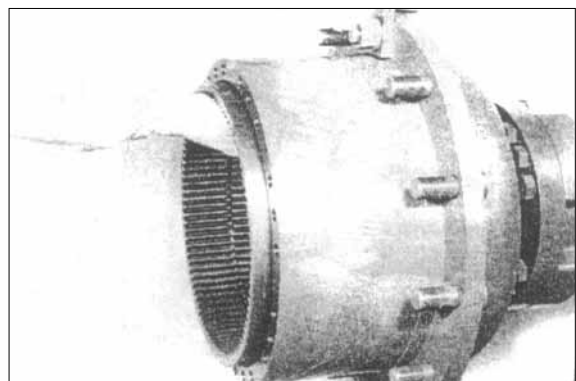

AX029

- ⑨ Tighten slotted nut by continuous turning of the hub.
 · Torque limit : 204~224kgf · m
 (1475~162 3lbf · ft).

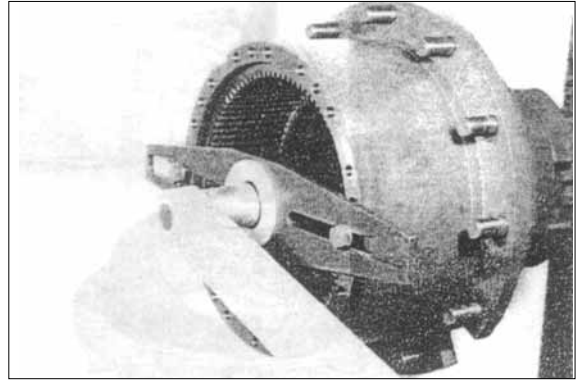

AX030

Rolling resistance of the wheel bearing

- ⑩ $T = F \times R$, from that results : Tractive Force
 $F = T/R$
 T = Rolling resistance in kgf · m
 F = Tractive Force kgf
 R = Radius in m

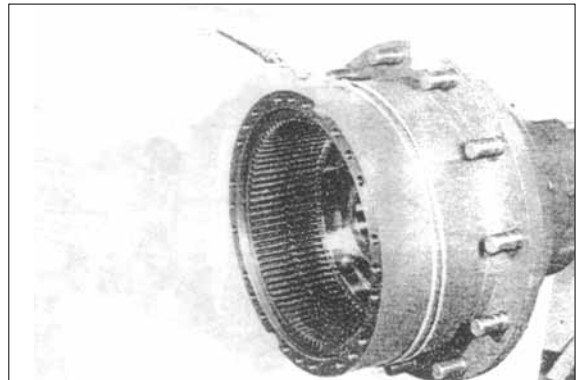

AX031

Nominal value/Bearing rolling moment :
 · 1.4~2.0kgf · m(10.3~14.8 lbf · ft)

- ※ For already run-in bearings try to find the lower value.
 If the required rolling resistance is not obtained correct by means of a corresponding spacer(Figure ⑦).
 After adjustment of the wheel bearing remove hub again.

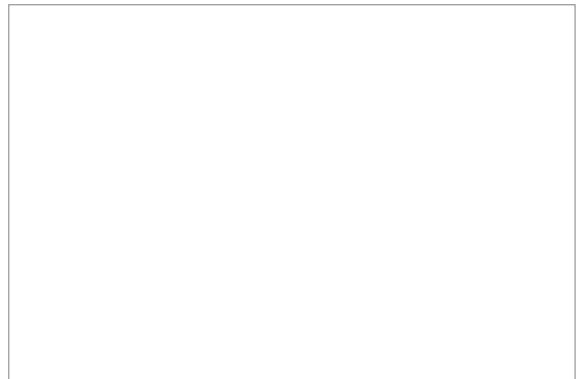

Hub

- ① Insert bearing inner race into the hub.



AX032

- ② Cover outside of shaft seal with Loctite and drive it in.
- ※ Installation depth(7.0~7.8mm) is determined by the special tool.
If necessary, heat cover plate prior to assemble the hub and install it.



AX033

- ③ Guide hub over the hub carrier end carefully against shoulder.

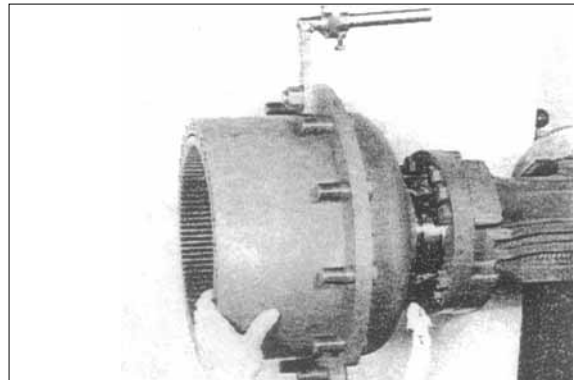

AX034

**Complete internal gear carrier
Pre-assemble piston**

- ④ The draft on the left shows the installation position of the back-up sealing elements.

- 1 = Back-up ring
- 2 = Packing ring
- 3 = U-section ring

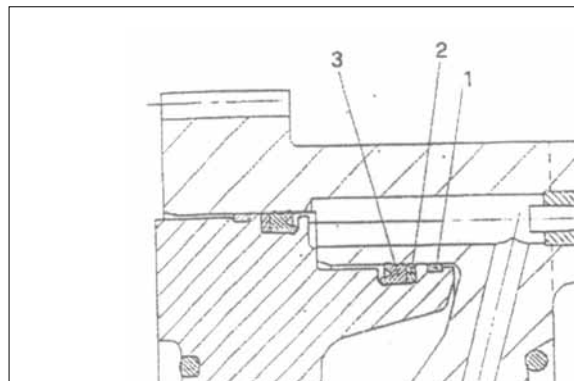

- ⑤ Clean the piston with spirit.
Stick on support ribbons at two points by means of Loctite. The support ribbons must adhere exactly around the whole circumference. Remove any sticking residues.

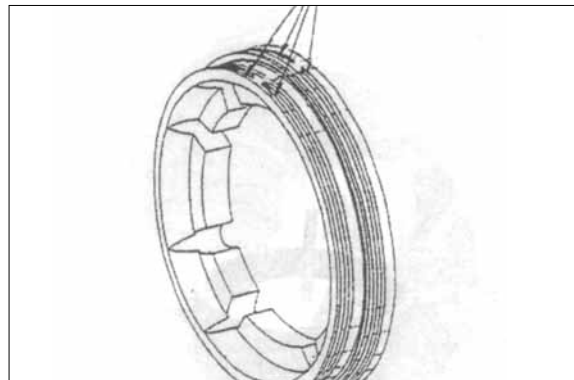

⑥ Install packing rings(2) and U-section rings(3).

※ Pay attention to the installation position, see draft ④, page 3-221.

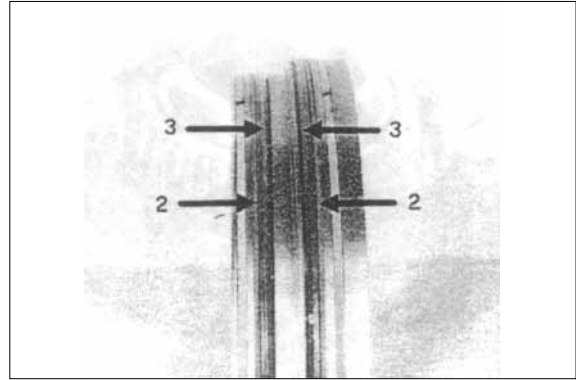

AX037

⑦ Insert piston into the installer(S).

※ Lubricate sealing and back-up elements, (Use W-10 oil).



AX038

⑧ Insert piston with installer into the internal gear carrier.

※ Pay attention to the radial installation position, (Openings for return springs). With installed condition, the support ribbon openings must show upwards.

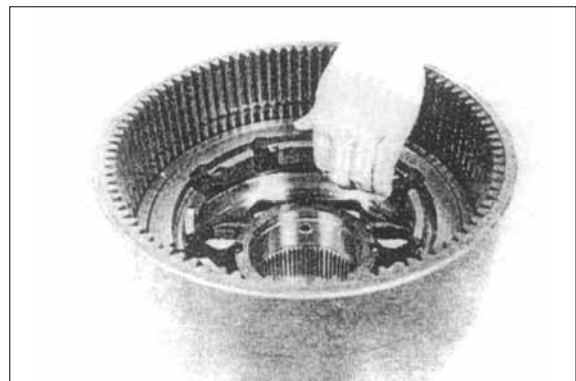

AX039

⑨ Press piston carefully against shoulder, using clamping plate and two-leg puller.

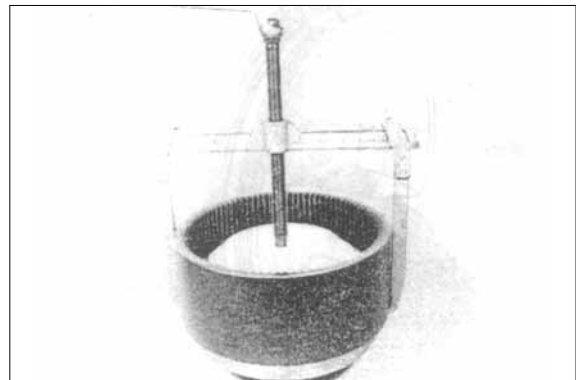

AX040

- ⑩ Engage return springs (With lug showing outwards) on the circlip and assemble it in the internal gear carrier.

※ Pay attention to the radial installation position of the circlip(See arrow).

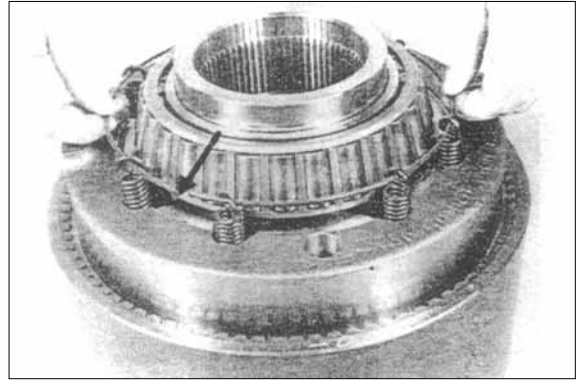

AX041

- ⑪ Insert 2nd circlip and engage return springs.

※ Pay attention to the radial installation position of the circlip.

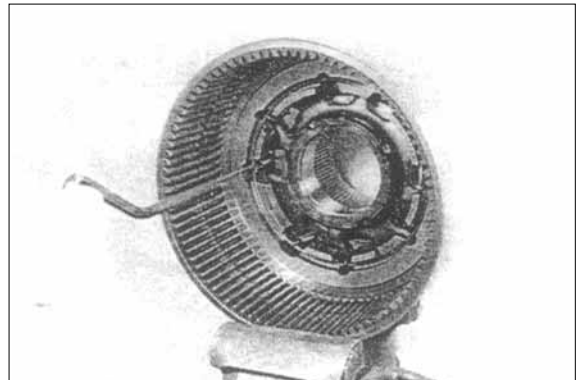

AX042

- ⑫ Insert O-ring into the groove of the internal gear carrier and grease it slightly. Mark the location of the oil supply holes on the face, (See arrow).

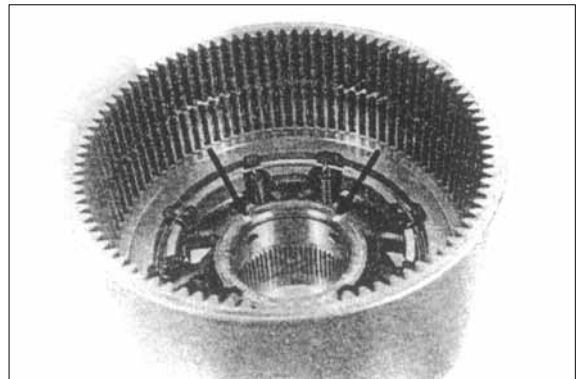

AX043

Assemble internal gear carrier

- ① Screw installer over the threads of the hub carrier. Assemble the spacer determined in Figure ⑦, page 3-222.

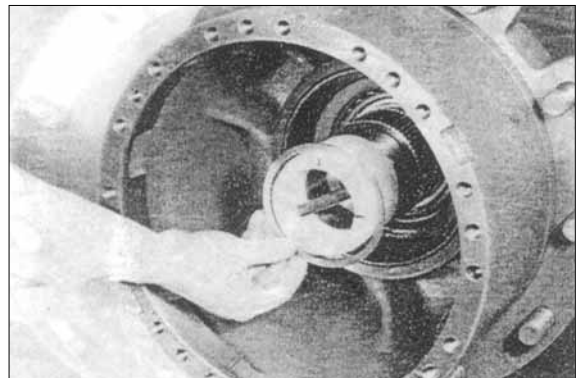

AX044

- ② Guide O-ring over the hub carrier and insert it into the groove.
Mark the radial location of the oil supply bores on the face(See arrows).

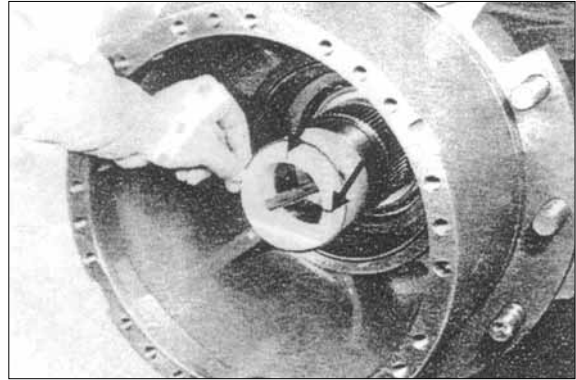

AX045

- ③ Guide the complete internal gear over the splines of the hub carrier. At the same time pay attention to the overlapping of the oil holes(Hub carrier, internal gear carrier)(See arrows).

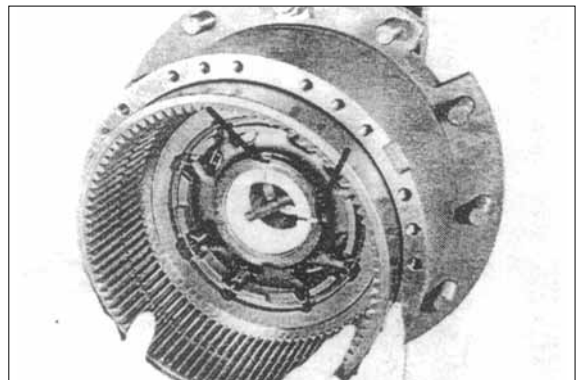

AX046

- ※ During this step, it is absolutely necessary to respect the central location of the hub in order to make a correct assembly of the internal gear-internal gear carrier possible, and to avoid a damage of the two O-rings.

- ④ Tighten slotted nut by continuous turning of the hub finally.

- Torque limit : 204~224kgf · m
(1475~ 1623lbf · ft)

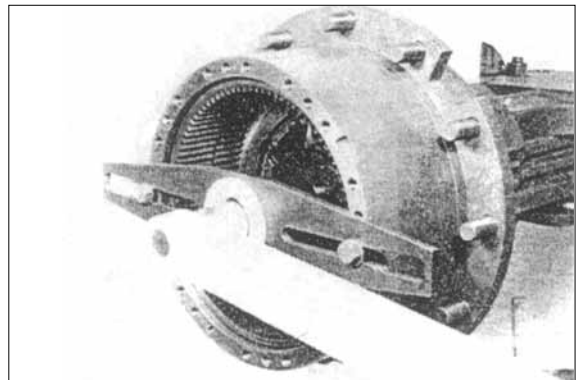

AX047

- ⑤ Install lock plate and secure slotted nut.

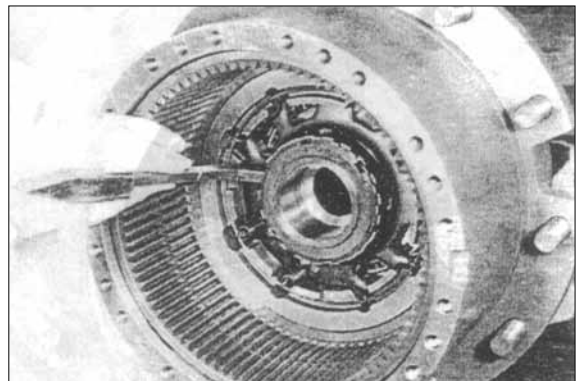

AX048

- ⑥ Assemble stub shaft until contact is obtained.

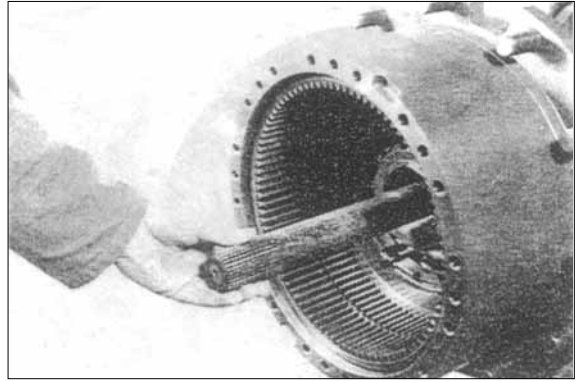

AX049

- ⑦ Screw oil seal with inner plate carrier.
• Torque limit : 5.1kgf · m(36.9lbf · ft)

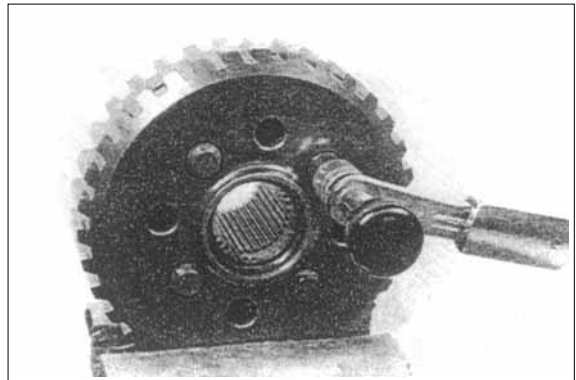

AX050

- ⑧ Install thrust washer.

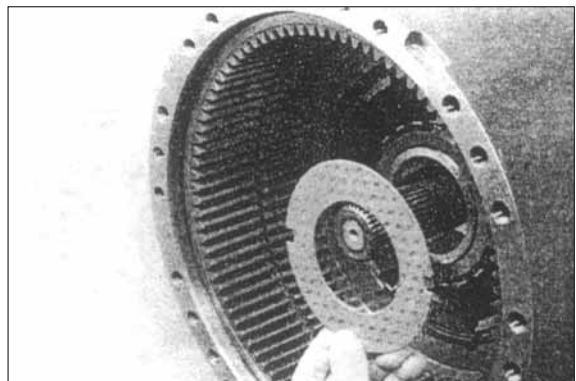

AX051

- ⑨ Guide the inner plate carrier(Along with the sun gear) upon the stub shaft splines.

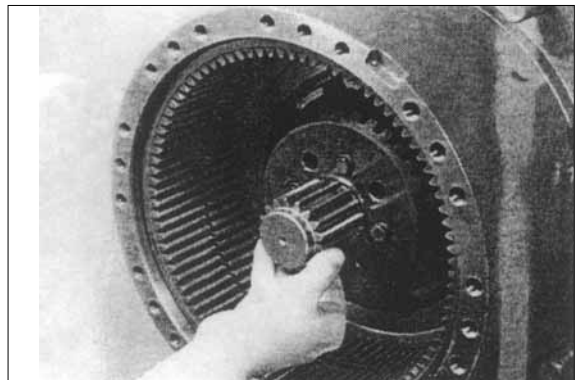

AX052

Adjust plate clearance according to the following table :

Number of inner plates	Number of friction faces	Plate clearance -piston stroke in (mm)
2	4	1.6~2.0
3	6	2.4~2.8
4	8	3.2~3.6
5	10	4.0~4.4



⑩ Determine piston stroke

(Nominal value 2.4~2.8mm)

Squeeze in circlip and place it against shoulder towards the outside.

Determine dimension A from the flange-mounted surface/hub to the plane surface/piston.

Dimension A e.g. 121.50mm

※ Pay attention to the correct location of the piston against the internal gear carrier.

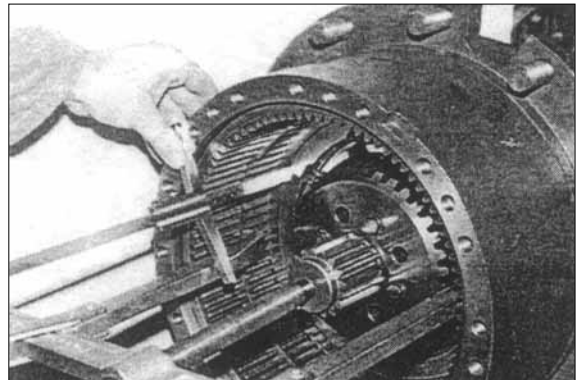

AX053

⑪ Measure dimension B from the flange-mounted surface/hub to the inner plane surface of the circlip.

Dimension B e.g. 75.20mm

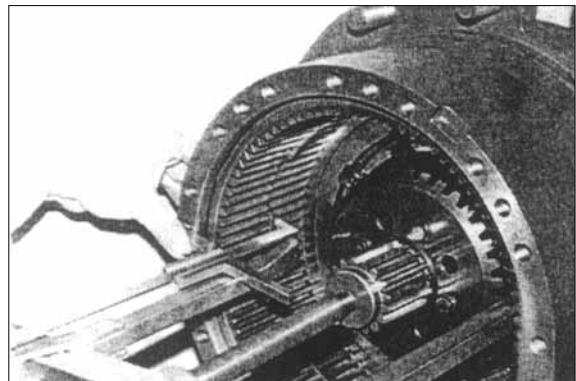

AX054

⑫ Outer plate : 4 × 4.5mm

Dimension C e.g. 18.00mm

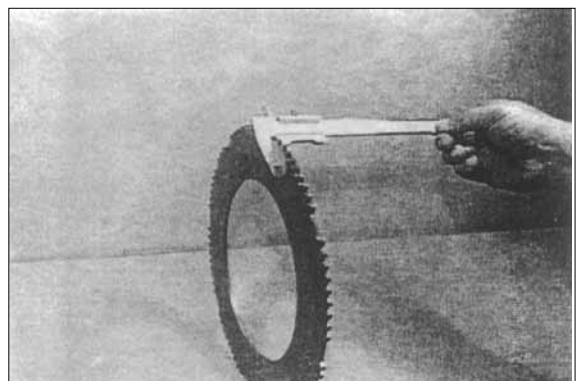

AX055

- ⑬ Inner plate : $3 \times 4.5\text{mm}$
 Dimension D e.g. 13.50mm

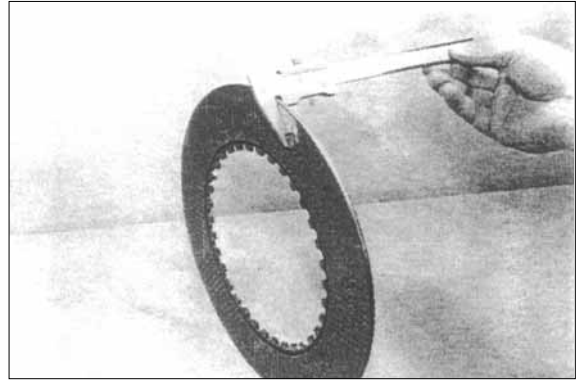

AX056

- ⑭ Dimension E = Backing plate
 Dimension E e.g. 18.00mm

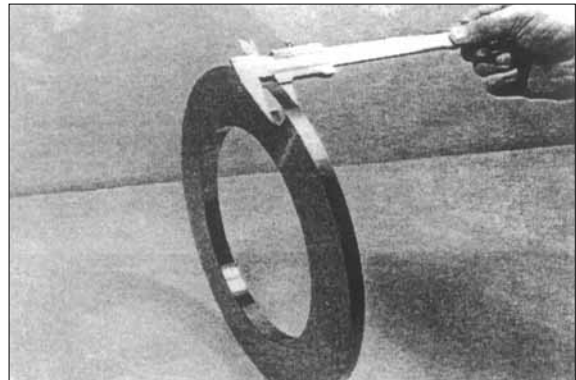

AX057

- ⑮ **Example**
- | | |
|------------------------------|----------|
| Dimension A | 121.50mm |
| Dimension B | -75.20mm |
| Dimension C | -18.00mm |
| Dimension D | -13.50mm |
| Dimension E | -12.00mm |
| Difference = Plate clearance | 2.80mm |

- ※ If the required plate clearance according to the Table, page 3-226, is not obtained, correct with corresponding outer plate.
 If necessary, mount thinner outer plates on the piston side, respectively backing plate side.

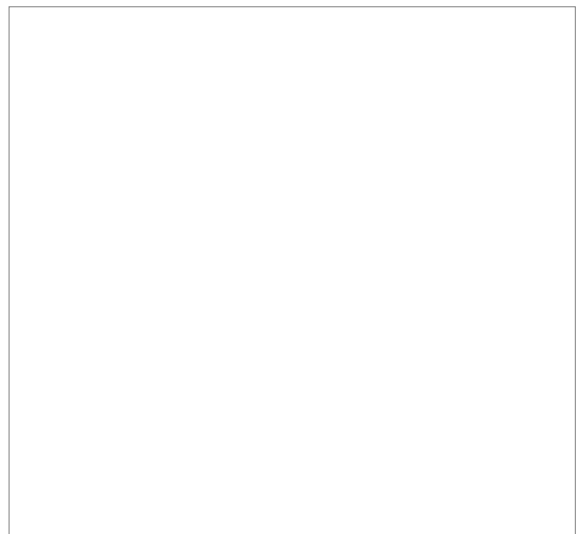

Install alternating outer and inner plates(Starting with one outer plate).

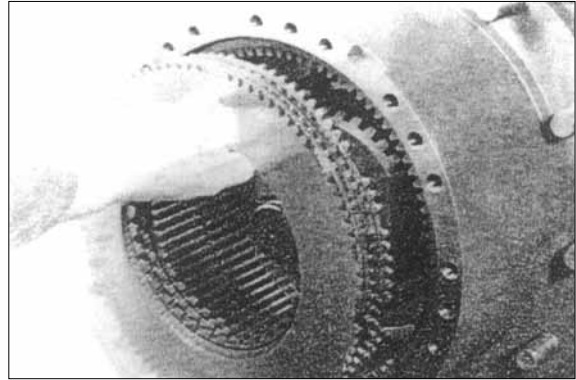

AX058

The illustration on the right shows the required arrangement of the outer plates.

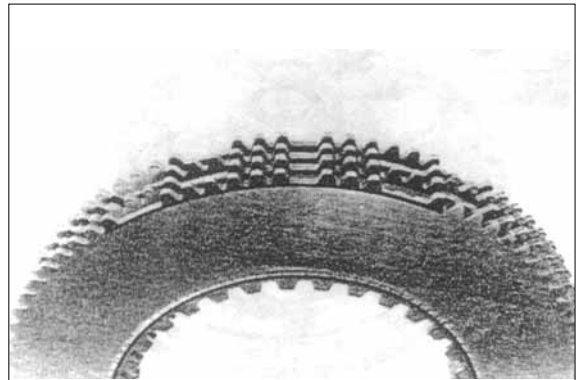

AX059

Insert backing plate-stepped plane surface is showing outwards.

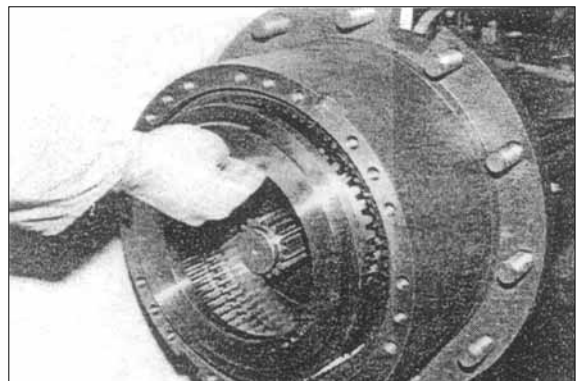

AX060

Fix the plate pack by means of circlip.

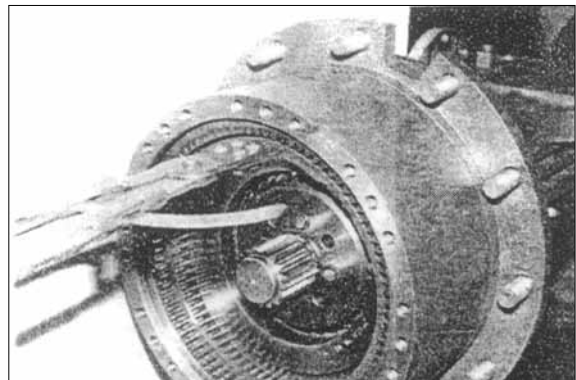

AX061

Heat planetary gear and place it upon the planetary carrier.

- ※ Pay attention to the installation position, large radius of the bearing inner race showing to the planetary carrier (Downwards).

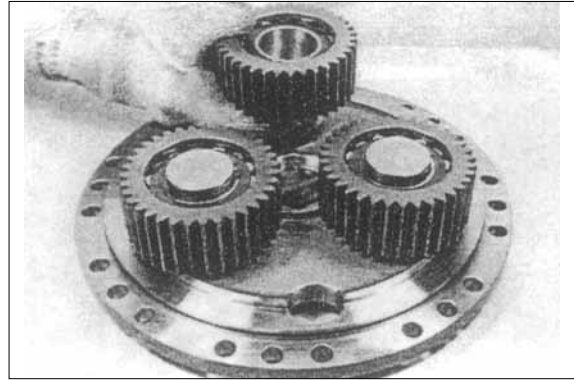

AX062

Squeeze in circlip.

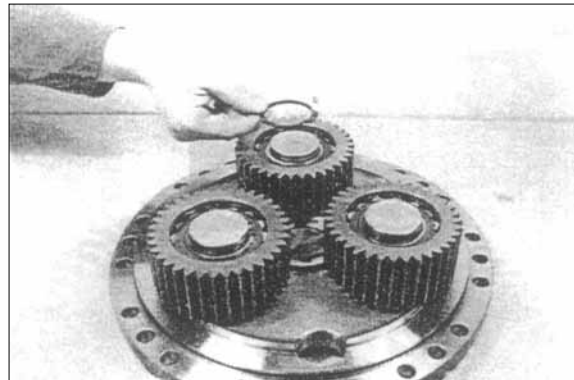

AX063

Determine end play of the sun-gear shaft(Nominal value 0.3~0.6mm)

(Try to find the higher value).

Place sun gear and plate carrier against shoulder.

Dimension A e.g. 6.00mm

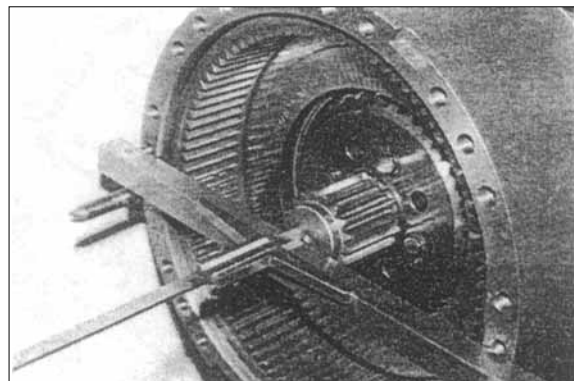

AX064

Determine dimension B from the flange-mounted surface to the thrust washer.

Dimension B e.g. 5.50mm

- ※ For the measurement, lay thrust washer into the planetary carrier.

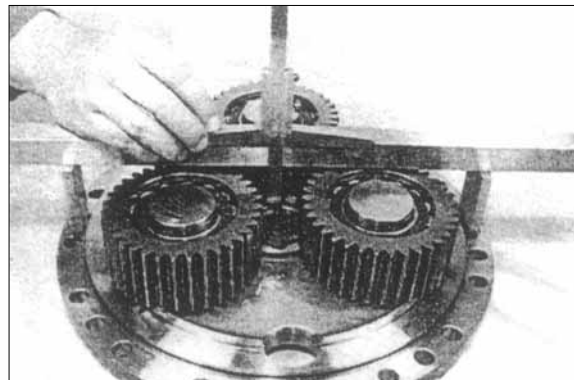

AX065

Example

Dimension A 6.00mm

Dimension B -5.50mm

Required end play =0.50mm

of the sun-gear shaft

- ※ Remove thrust washer again and make it adhere with Loctite.



Insert new O-ring into the ring groove of the planetary carrier(Arrow).

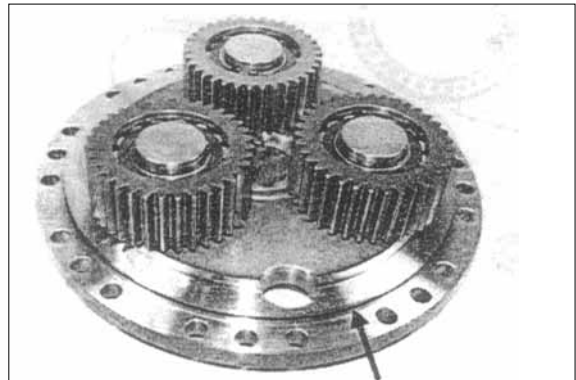

AX066

Assemble planetary carrier until contact is obtained.

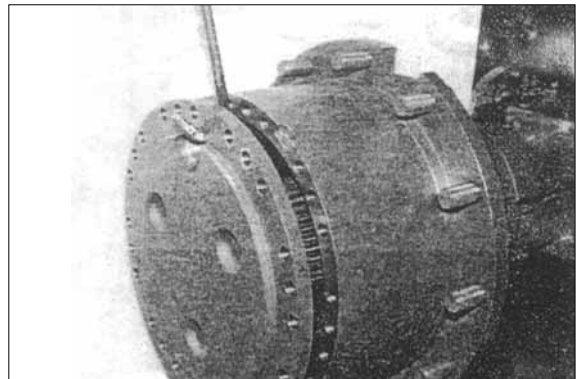

AX067

Tighten hexagon head screws.

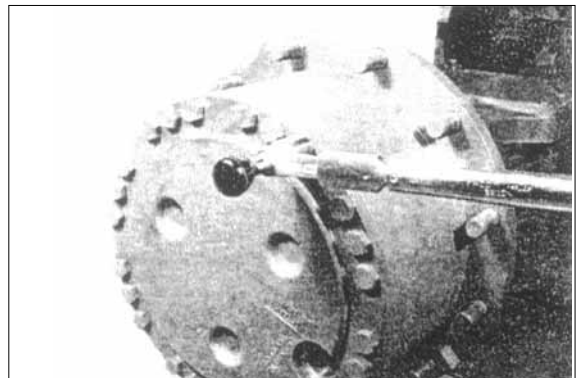

AX068

Check tightness of the brake hydraulic system

※ Bleed the brake.

After having applied the brake for about 10 times carry out the following pressure test.

Using a suitable pressure apparatus (Lukas or similar) with stopcock build up an actuating pressure of 120 bar.

Close the stopcock and pressurize the brake for 5 minutes with this pressure.

After this time, the pressure may have dropped to 117 bar only.



Afterwards, build up a pressure of 5 bar and close the stopcock.

Within 5 minutes there may be no pressure break.

Install bleeder valve.

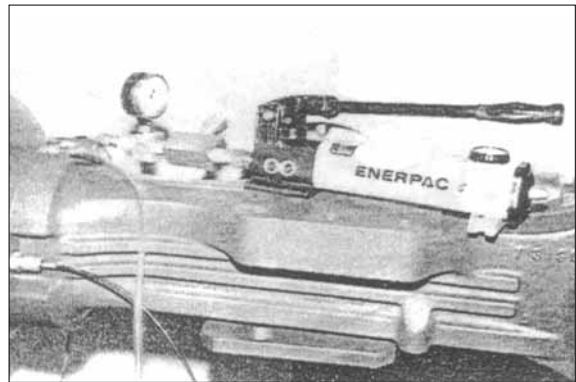

AX069

Tighten oil drain plug.

- Torque limit : 5.1kgf · m(36.9lbf · ft)

※ Before the axle is put into Service, pay attention to the Lubrication Instructions, page3-201.



AX070

2) DIFFERENTIAL CARRIER

(1) DISASSEMBLY

Remove the two stub shafts prior to separate the differential carrier from the axle housing, see figure ①~③.

- ① Drain oil from the final drive and the axle housing. Loosen hexagon head screws and separate planetary carrier from the hub, using eye hook.

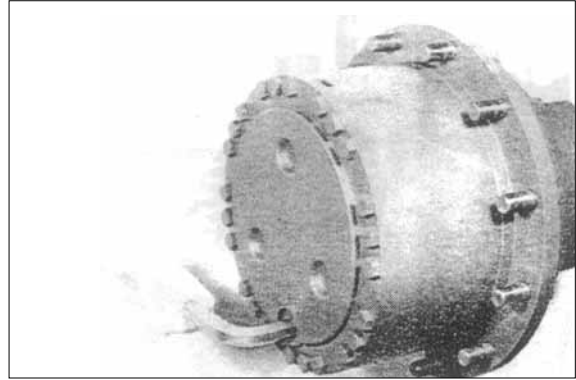

AX071

- ② Pull inner plate carrier (Along with sun gear) from the stub shaft.

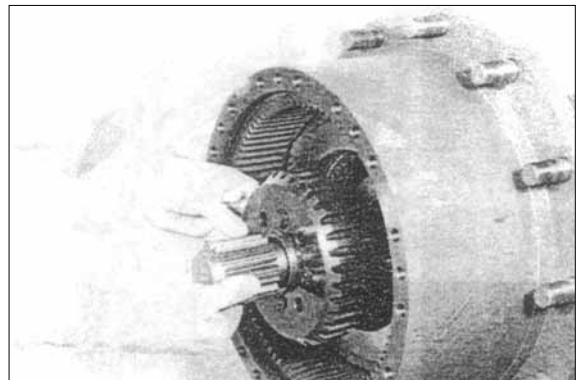

AX072

- ③ Pull stub shaft out of the axle housing. Squeeze out circlip and remove the plate pack.

※ This step is necessary to make the later installation of the inner plate carrier possible.

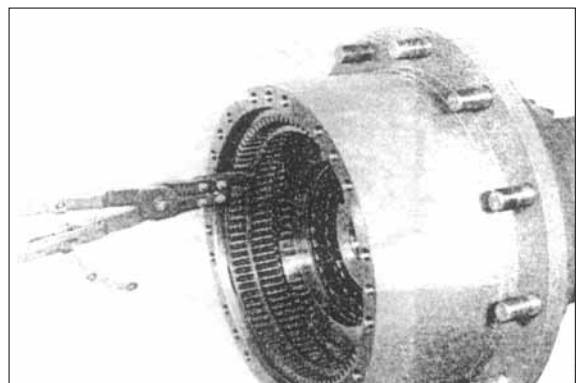

AX073

- ④ Loosen hexagon head screws and separate the differential carrier from the axle housing.

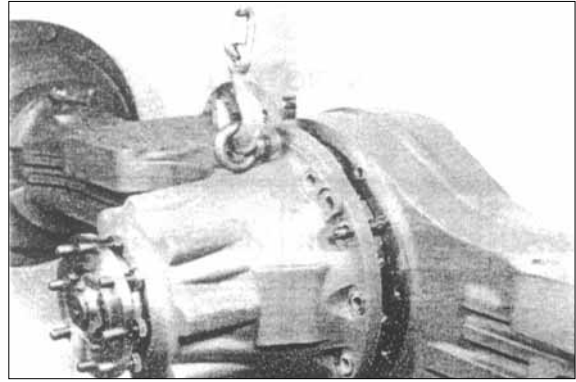

AX074

- ⑤ Fasten the differential carrier in the assembly jig.
Remove lock wire and drive roll pins out.

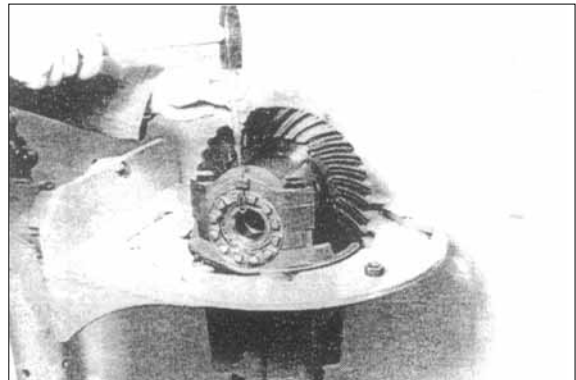

AX075

- ⑥ Loosen adjusting nuts.



AX076

- ⑦ Loosen hexagon head screws and remove the two bearing caps.
※ Mark bearing caps with housing, see arrow.

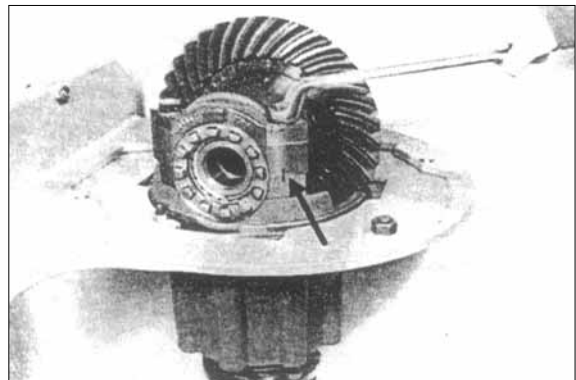

AX077

- ⑧ Remove adjusting nuts.
Remove differential assembly from the axle carrier.

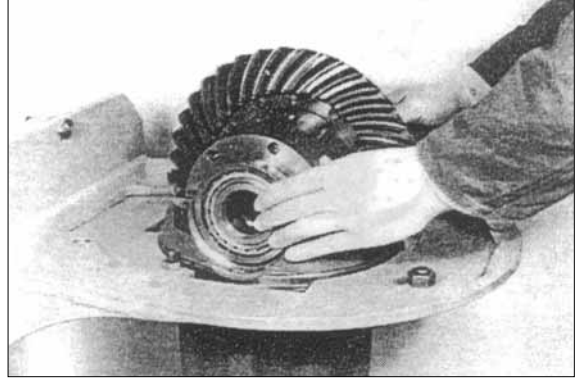

AX078

Differential

- ① Pull the two bearing inner races of the tapered roller bearing from the differential case halves.

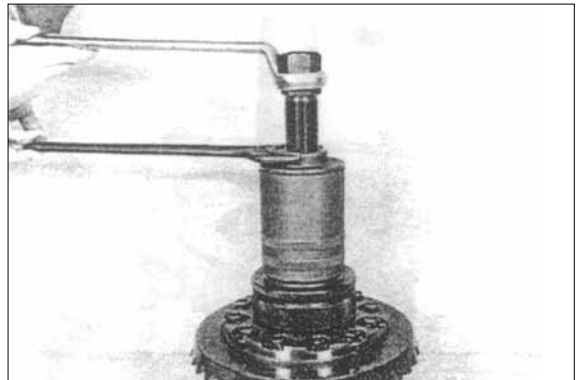

AX079

- ② Mark housing cover with differential.
Clamp the differential case halves, loosen the locking screws.

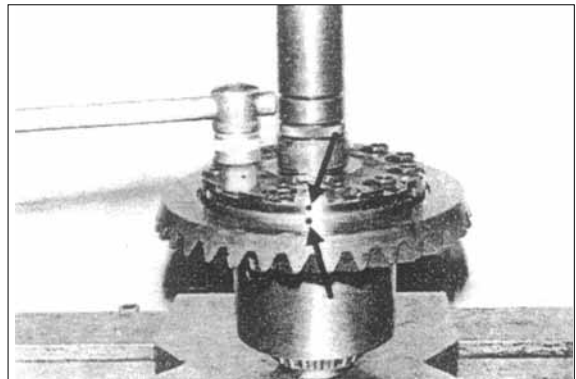

AX080

- ③ Back off the cover.
※ Pay attention to the released thrust washer.

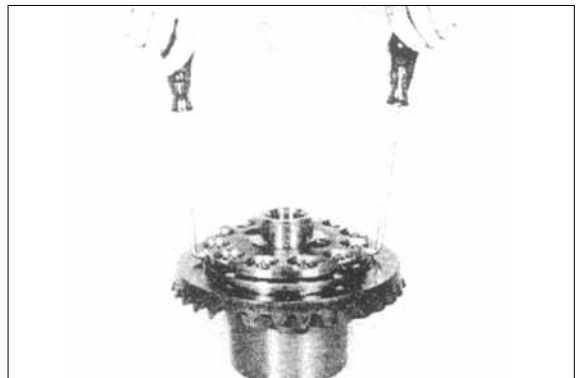

AX081

- ④ Take all components of the multi-disk self-locking differential out of the differential case.

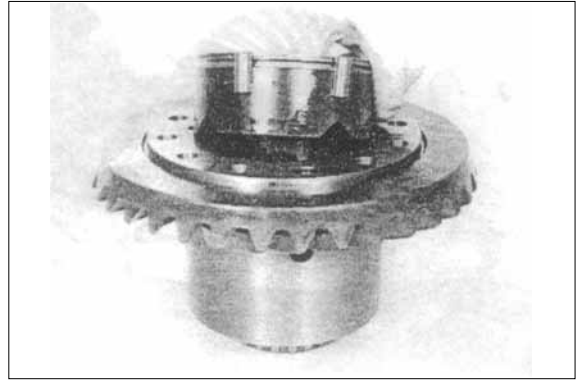

AX082

- ⑤ Press crown wheel from the differential case.

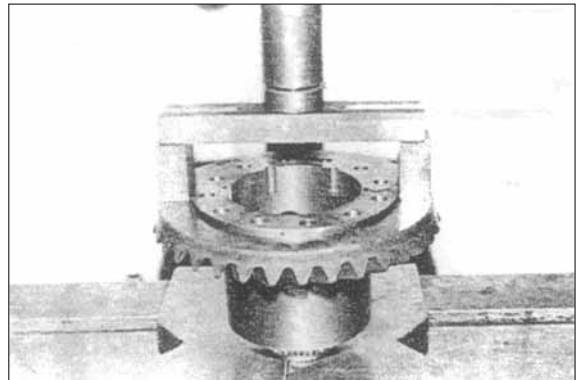

AX083

Drive unit

- ① Unlock slotted nut or hexagon head screw(According to the version) and remove lock plate.

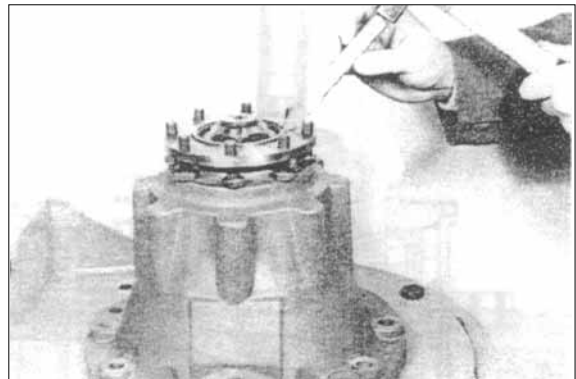

AX084

- ② Loosen slotted nut or hexagon nut(According to the version) and remove it along with washer.

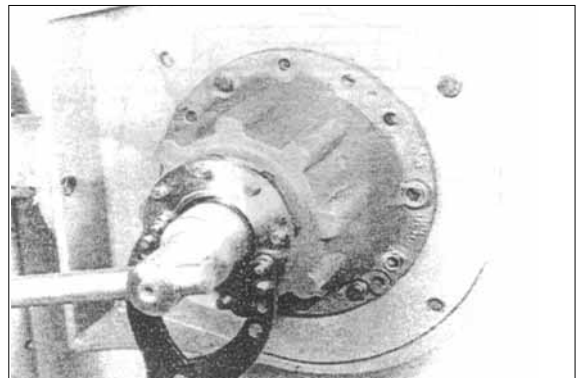

AX085

- ③ Pull off the drive flange.

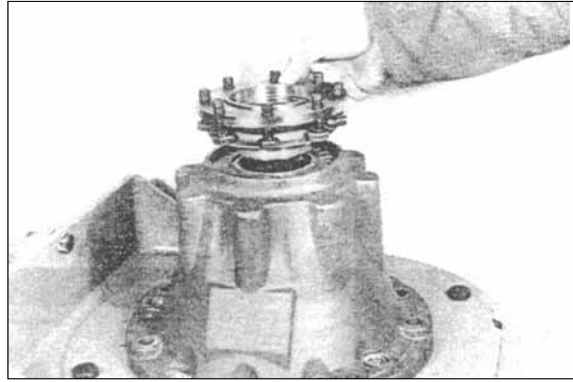

AX086

- ④ Pry out the shaft seal.

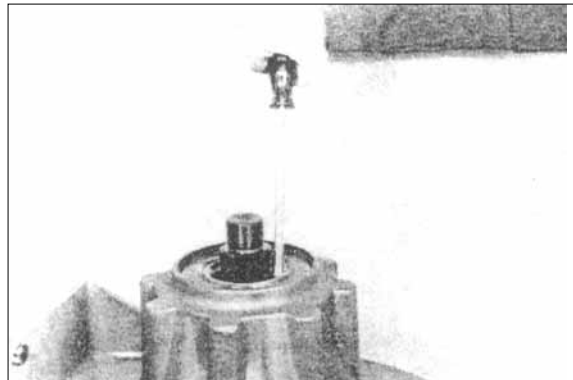

AX087

- ⑤ Press drive pinion out of the axle carrier.
※ Pay attention to the released tapered roller bearing.

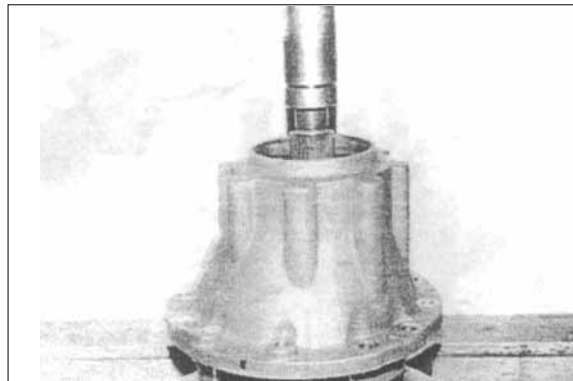

AX088

- ⑥ Remove spacer from the drive pinion end.



AX089

- ⑦ Press tapered roller bearing from the drive pinion, using grab sleeve(See arrow.).

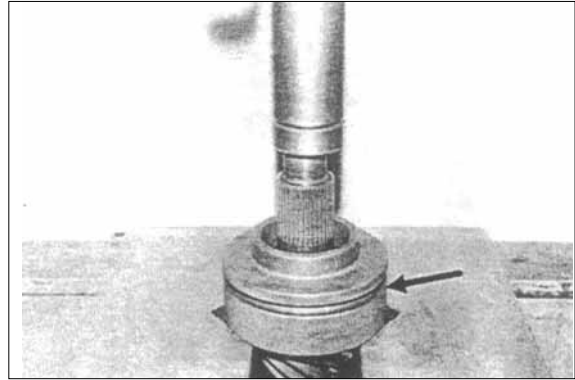

AX090

- ⑧ If necessary, drive the two bearing outer races out of the axle carrier bores.

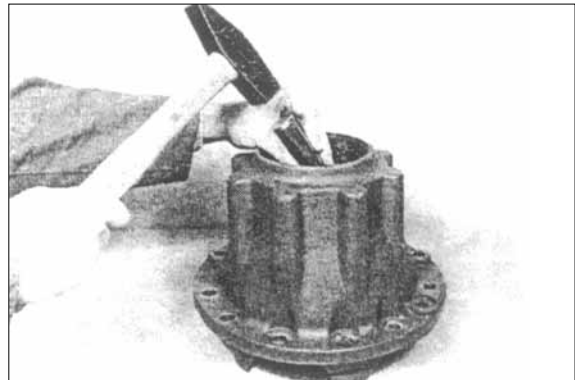

AX091

(2) Assembly

- ※ If crown wheel or drive pinion are damaged, the two parts must be renewed as a set.

If a new complete crown wheel set is installed, pay attention that crown wheel and drive pinion have the same mating numbers.

When replacing a complete crown wheel set or axle carrier, pay attention to the Draft.

Determine thickness of shim-to obtain a correct contact pattern

- ※ The following measuring operations must be carried out with utmost care.

Inexact measurements would cause an incorrect contact pattern and require a renewed disassembly and assembly of the drive pinion as well as the differential(Partial) after the contact pattern has been taken, page3-202.

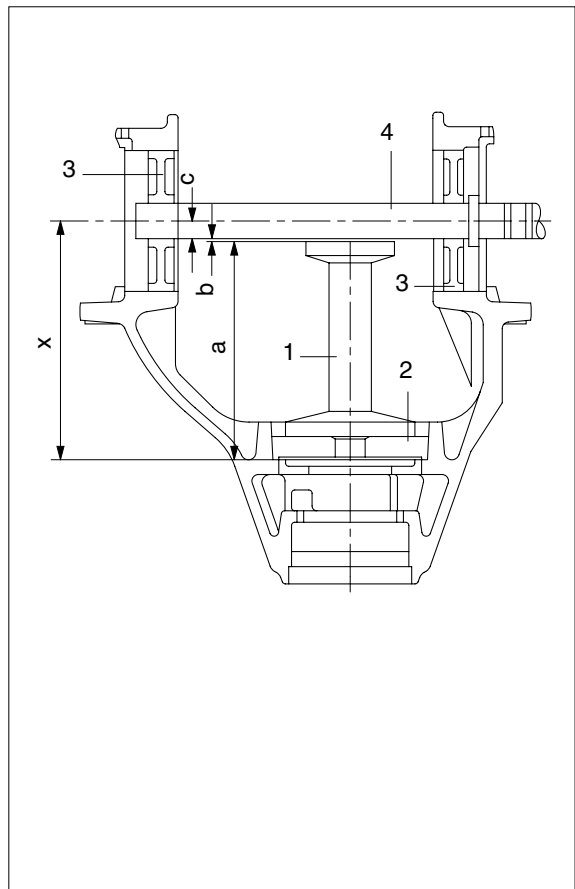

Install adjusting pieces(3) and fasten the two bearing caps provisionally.
 Install stop washer(2) and measuring pin(1) and introduce measuring shaft(4) (See draft).

CK-Drive

- 1 = Measuring pin
- 2 = Stop washer
- 3 = Adjusting piece
- 4 = Measuring shaft

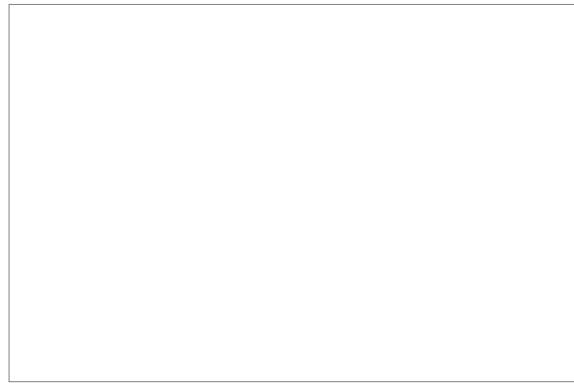

- ① Determine gap(Dimension b) between measuring pin and measuring shaft with feeler gauge.

Dimension b e.g. 0.70mm

EXAMPLE I

Dimension a(=measuring piston)	166.80mm
Dimension b	+0.70mm
Dimension c (1/2 ø measuring shaft)	<u>+15.00mm</u>
gives Dimension X	<u>182.50mm</u>

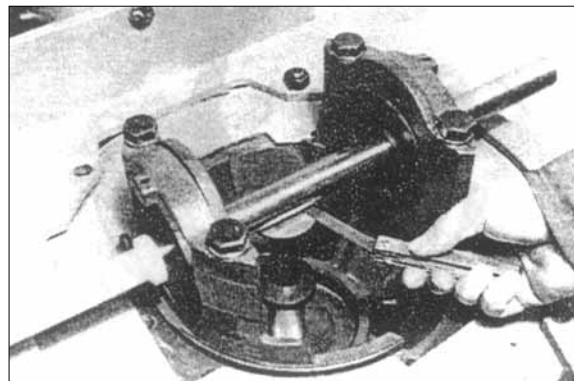

AX092

- ② Measure bearing width.

Bearing width e.g. 33.50mm

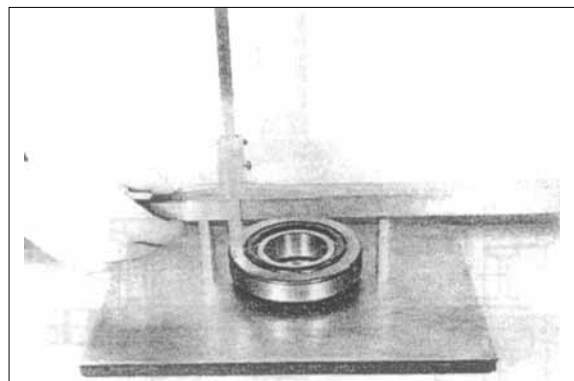

AX093

- ③ Read pinion dimension.

Pinion dimension e.g. 148.0^{-0.2}

147.80mm

EXAMPLE II

Bearing width	<u>33.50mm</u>
Pinion dimension	<u>+147.80mm</u>
gives dimension X1	181.30mm

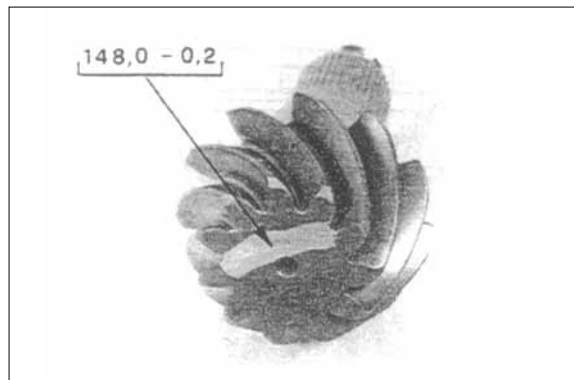

AX094

Adjust rolling resistance of the drive pinion bearing

- ① Nominal value : DK/CK 0.11~0.23kgf · m
HK 0.15~0.31kgf · m
LK/RK 0.31~0.46kgf · m

Lay measuring ring over the drive pinion collar.

- ※ Configuration and description of the measuring ring, see below draft.

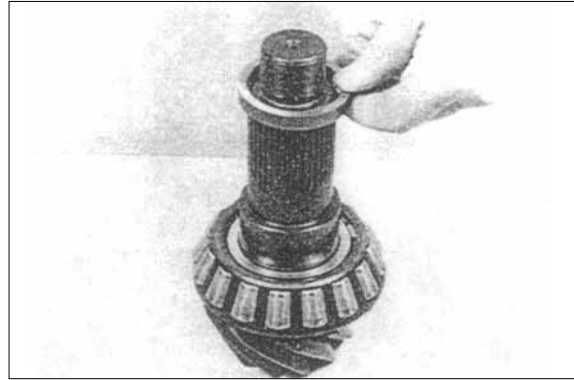

AX098

Draft for the determination of the spacer :

1 = Measuring ring

2 = Roll pin (Set of 3, each spaced for 120°)

- ※ Dimension X = Thickness of spacer.

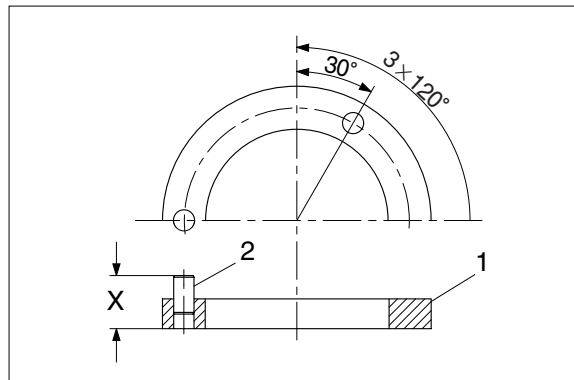

- ② If necessary (According to the version), insert hexagon head screws into the drive flange bores and press the dust shield upon the collar of the drive flange.



AX099

- ③ Insert the drive pinion into the axle carrier and assemble the heated bearing inner race until contact is obtained.

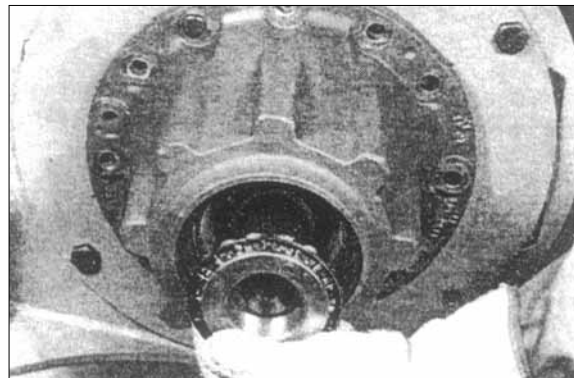

AX100

- ④ Guide drive flange over the drive pinion splines.

Apply washer and tighten slotted nut until the required rolling resistance is obtained.

- ※ When tightening, make several full revolutions of the drive pinion in both senses, and check the rolling resistance continuously.

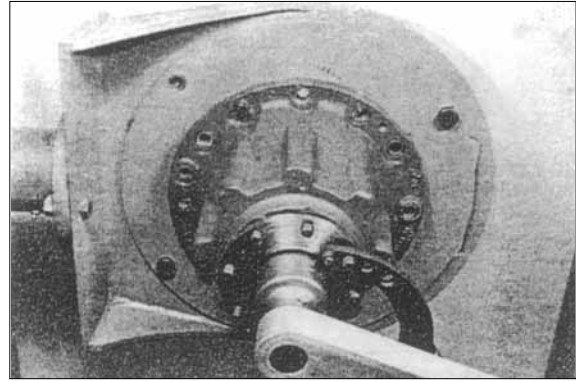

AX101

- ⑤ Loosen slotted nut, pull off drive flange and remove the pinion again.

Take off measuring ring and determine dimension X (See draft, page 3-240).

Dimension X e.g. $s=8.55\text{mm}$

- ※ Dimension X corresponds to the thickness of the spacer to be installed.

Lay spacer (e.g. $s = 8.55\text{mm}$) instead of the measuring ring over the drive pinion end.

Install drive pinion again.

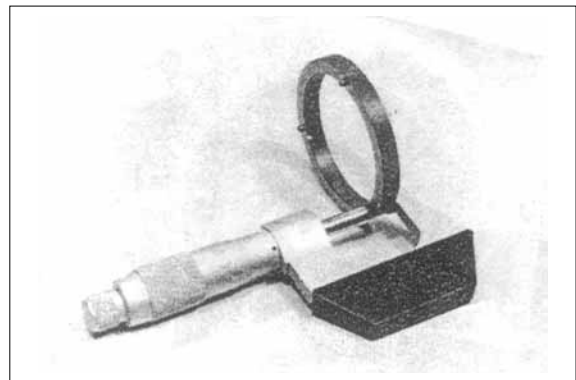

AX102

- ⑥ Replace drive flange, apply washer and tighten slotted nut.

· Torque limit : RK	112kgf · m
LK	122kgf · m
CK	71kgf · m

- ※ When tightening, make several full revolutions of the drive pinion in both senses.

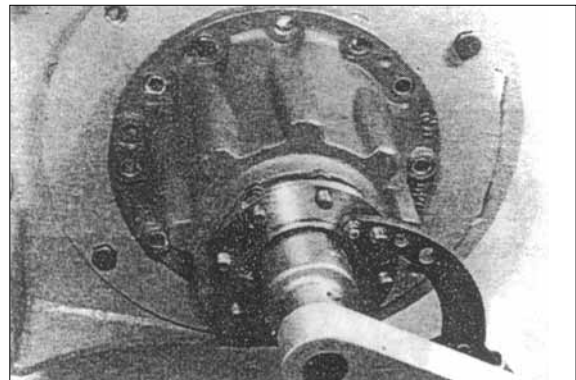

AX103

- ⑦ Check rolling resistance.

- ※ If the required rolling resistance is not obtained correct again with one corresponding spacer.

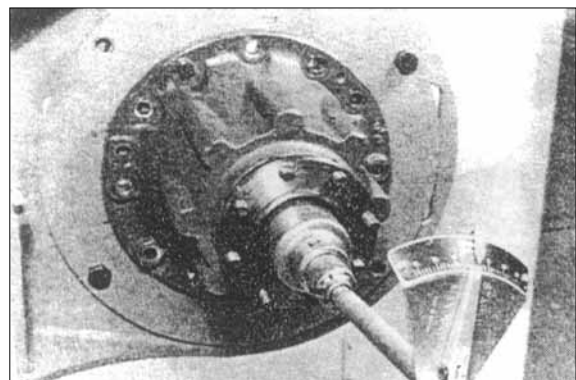

AX104

⑧ Remove the drive flange and install the shaft seal.

※ Pay attention to the contact.

If the shaft seal outer diameter is rubber-coated, the sealing face must be wetted with spirit.

Otherwise use sealing compound Loctite
Fill cavity between sealing lip and dust lip with grease.

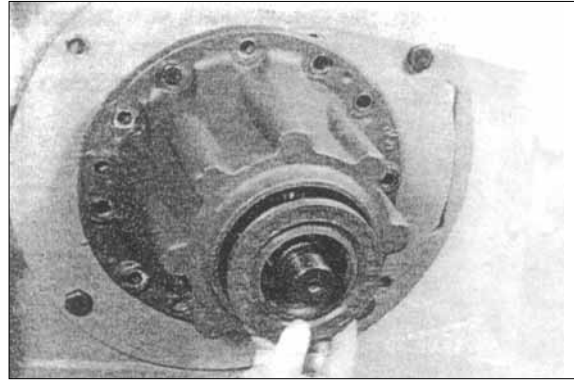

AX105

⑨ Replace drive flange, assemble washer and tighten slotted nut, respectively hexagon nut(According to the version) finally.

· Torque limit : RK 112kgf · m
 LK 122kgf · m
 CK 71kgf · m

※ The securing of the slotted nut, respectively hexagon nut(According to the version) is carried out after the contact pattern is taken.

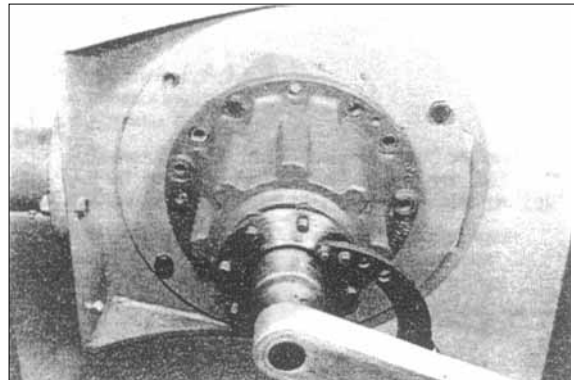

AX106

Differential

① Heat the crown wheel, center and fasten it provisionally.

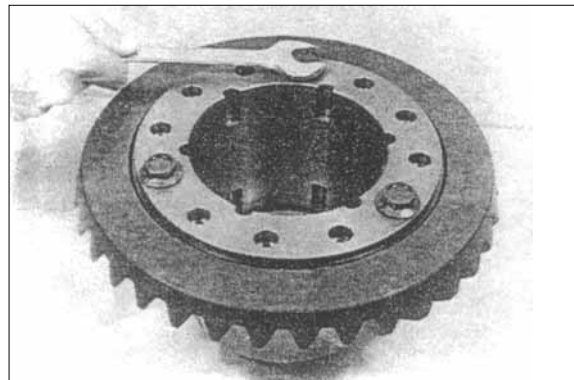

AX107

② Insert the two thrust washers into the differential case half.

※ Mount the brass washer on top with the lubricating groove facing the side gear.

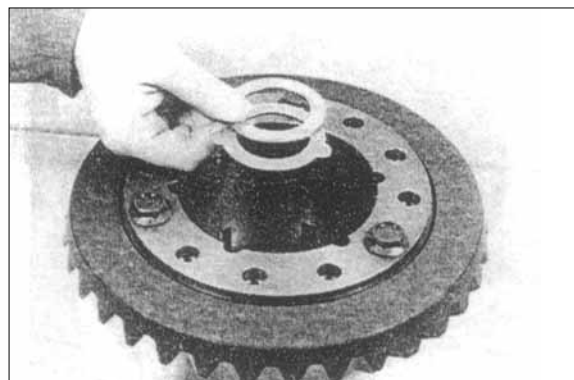

AX108

- ③ Insert circlip and install drive pin.

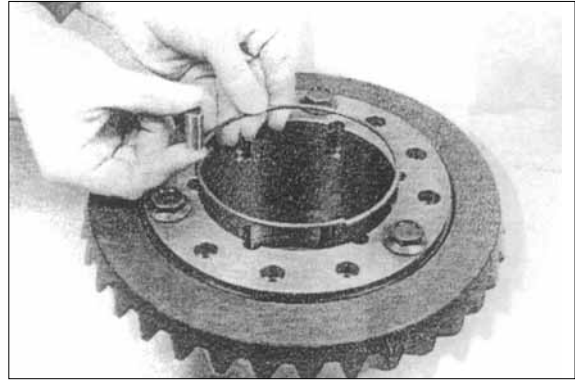

AX109

- ④ Assemble alternating outer and inner plates, starting with one outer plate.

※ Number and installation position of the outer and inner plates, see corresponding spare parts list (According to the version).

The total height(Thickness) of the plate pack must be equal on both differential sides. Plate thickness of outer plates may be different.

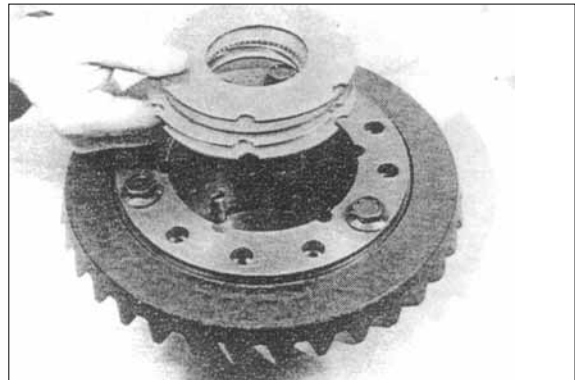

AX110

- ⑤ Mount pressure ring.

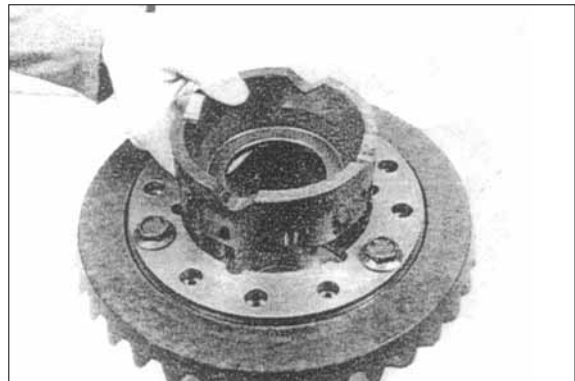

AX111

- ⑥ Insert side gear and assemble inner plates at the same time.

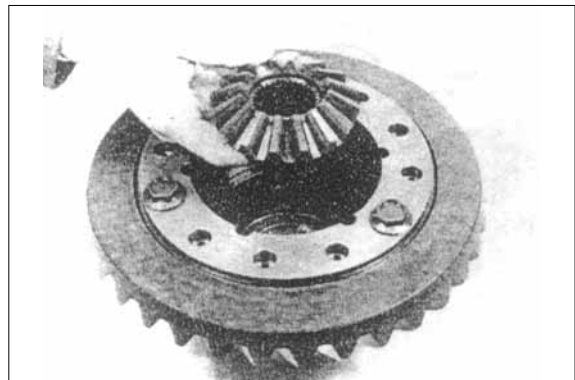

AX112

⑦ Insert the complete differential spider.

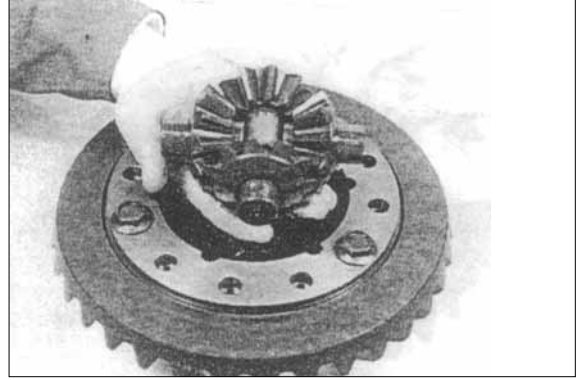

AX113

⑧ Replace the second side gear.

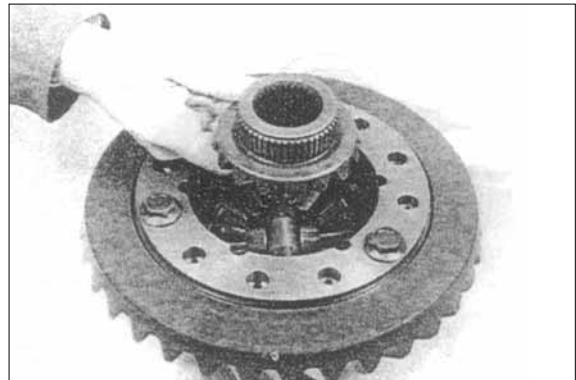

AX114

⑨ Install the second pressure ring and insert all drive pins.

※ Pay attention to the radial installation position of the pressure ring.

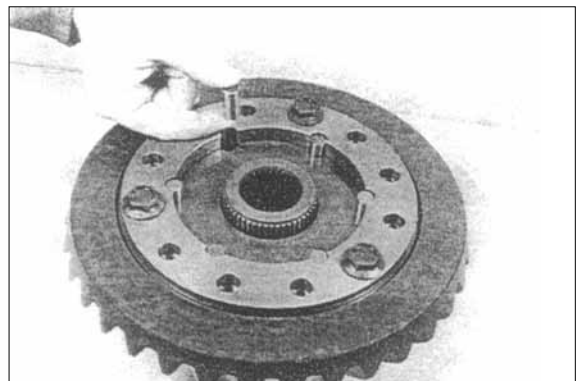

AX115

⑩ Assemble alternating inner and outer plates, starting with one inner plate.

※ Number and installation position of the inner and outer plates, see corresponding list of spare parts(According to the version).

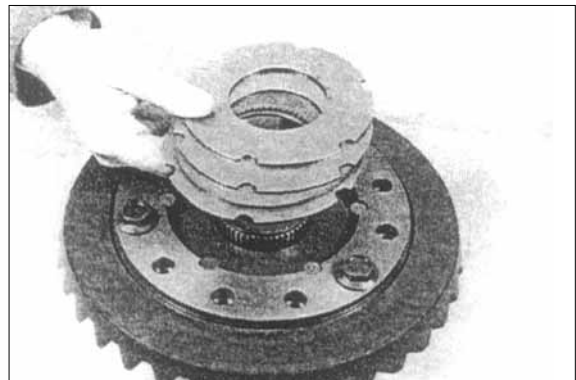

AX116

Determine plate clearance

⑪ Differential case :

Measure dimension A from the flange-mounted surface to the outer plate.

Dimension A e.g. 3.40mm

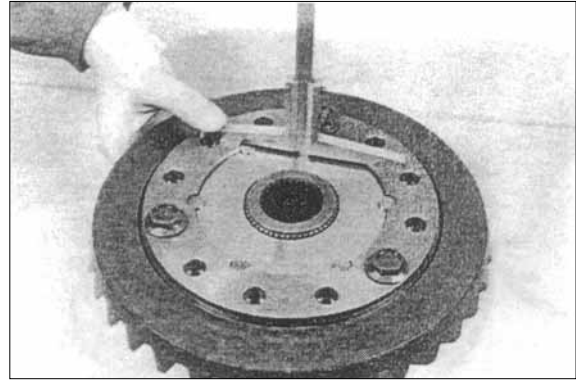

AX117

⑫ Housing cover :

Determine dimension B from the contact face(Outer plate) to the flange-mounted surface.

Dimension B e.g. 3.10mm

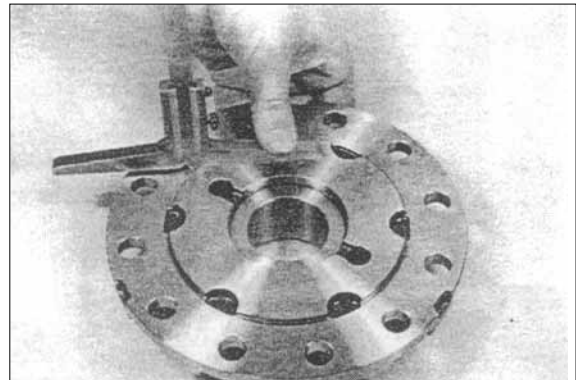

AX118

⑬ **EXAMPLE**

Dimension A 3.40mm

Dimension B -3.10mm

Difference = Plate clearance 0.30mm

- ※ The prescribed end play(=plate clearance) is 0.2~0.8mm, whilst the lower value should be found.

The end play is corrected by installing outer plates of corresponding thickness, whilst the plate thickness must be equal on both differential sides.

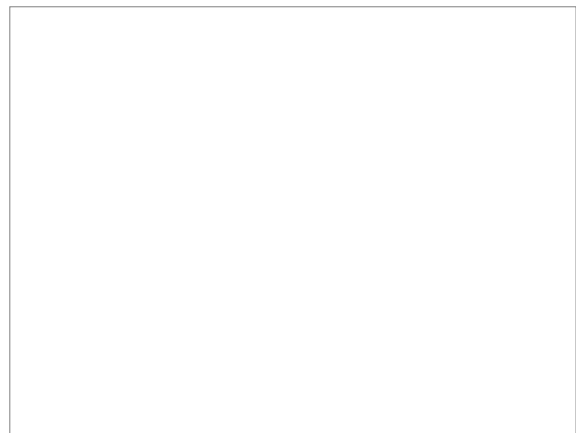

- ⑭ Make the two thrust washers adhere with grease in the housing cover.

- ※ Mount the brass washer on top with the lubricating groove facing the side gear.

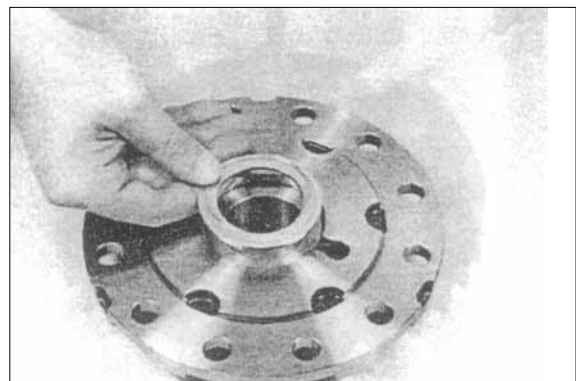

AX119

- ⑮ Fasten the housing cover by means of locking screw.
※ Pay attention to the installation position - see markings.
Only single use of the locking screws is admitted.

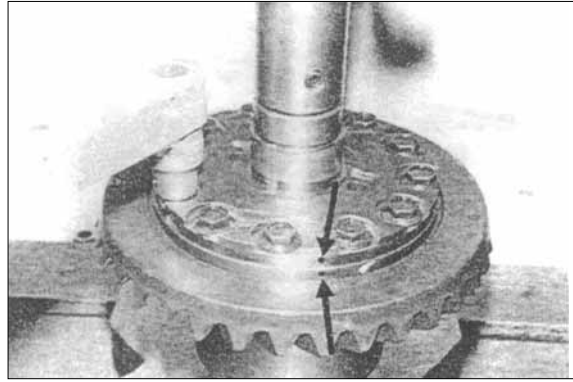

AX120

Heat the two bearing inner races and place them against shoulder.

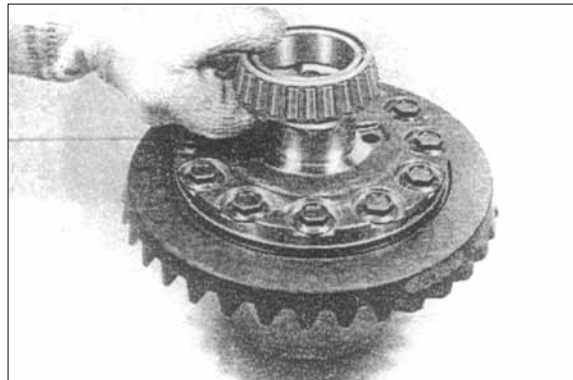

AX121

Install the two bearing outer races and insert the differential assembly into the housing.
Now, fix the differential by means of the adjusting nuts.

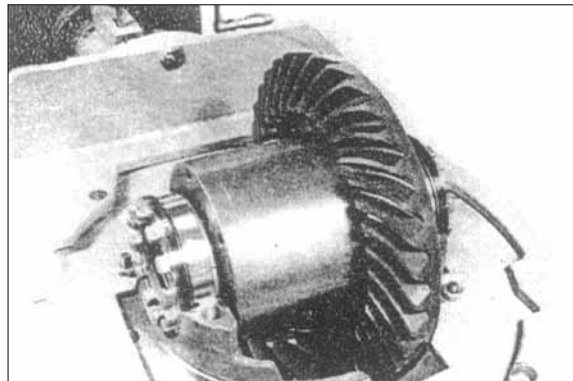

AX122

- Install the two bearing caps and tighten them by means of hexagon head screw.
※ Pay attention to the marking(Arrow).

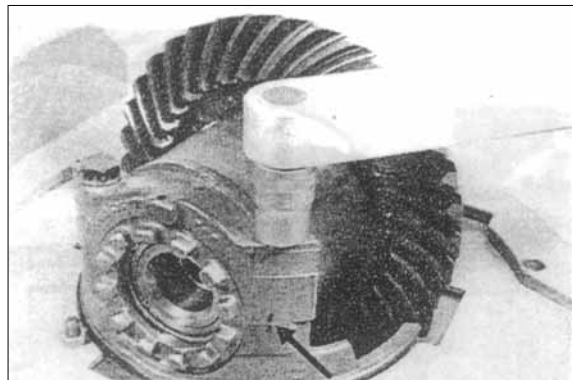

AX123

Adjustment of the bearing preload and the backlash

Apply dial indicator right angled on the outer diameter of the tooth flank/crown wheel.

Adjust the adjusting nut on the crown wheel side until the required backlash-see value engraved on the crown wheel outer diameter- is obtained.

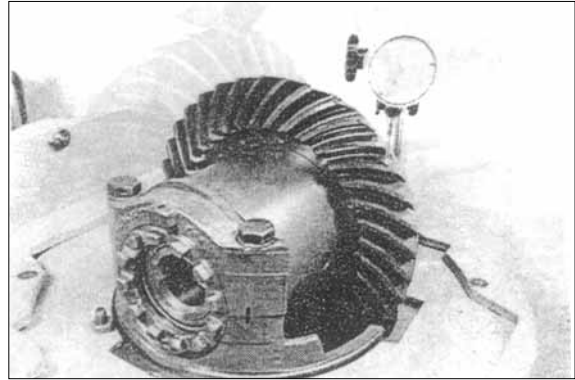

AX124

Screw in the adjusting nut(Opposite the crown wheel side) until the differential bearing is free of play.

Now, tighten adjusting nut further for 2 notches to obtain the required bearing preload of the differential bearing 0.3~0.4kgf · m.

Check backlash again and correct if necessary.

※ At this step make several full revolutions of the differential.

Determine yoke width ;

e.g. CK 258+0.1mm

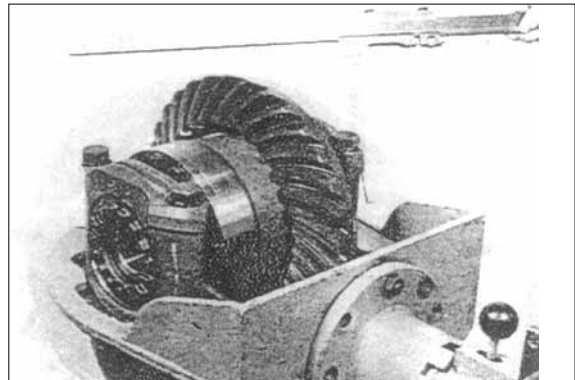

AX125

Apply dial indicator on the plane face/crown wheel, make at least one revolution of the crown wheel and record the run-out.

Admitted run-out maximum 0.08mm.

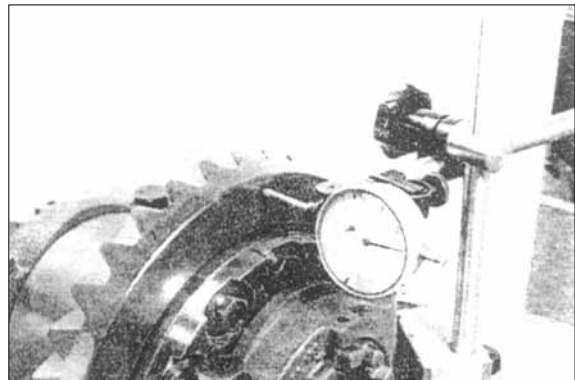

AX126

Check contact pattern on the crown wheel : Cover some tooth flanks of the crown wheel with gear marking compound. Roll the crown wheel over the drive pinion to and fro. Take the contact pattern and compare it with Page "Examples of contact patterns", page 3-202.

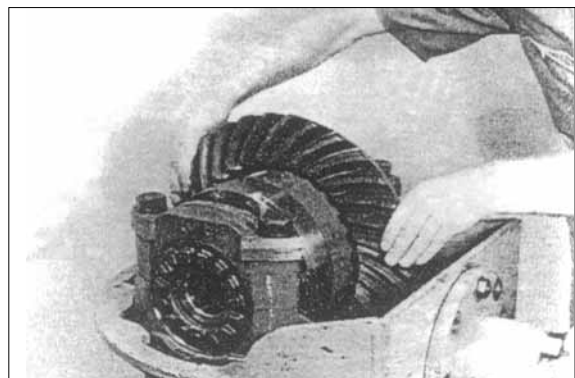

AX127

In case of a greater contact pattern deviation a spacing error has been made during the assembly of the drive pinion which must be absolutely corrected.
Fix the two adjusting nuts by means of toll pins, respectively cotter pins (According to the version).

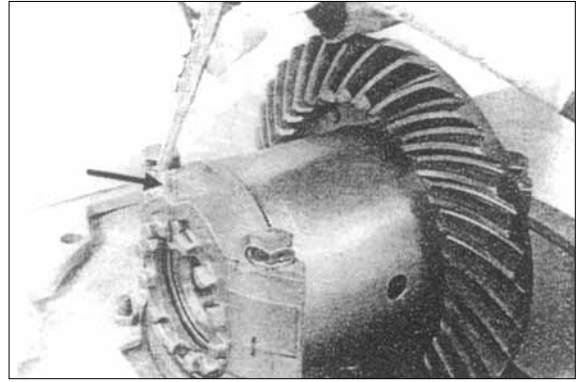

AX128

Secure hexagon head screws of the bearing cap fastening against getting loose by means of lock wire(\varnothing 1.6mm).

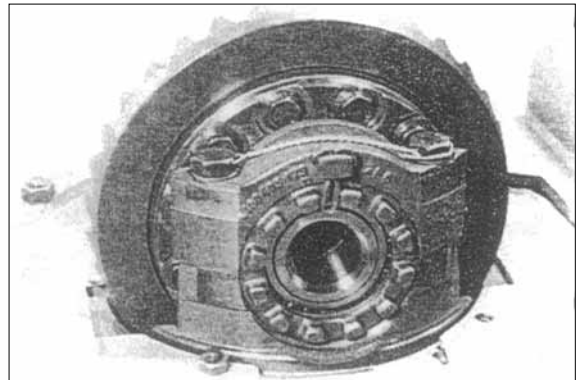

AX129

Tilt differential carrier.
Insert lock plate firmly against shoulder and caulk it on the drive flange, using a suitable tool.



AX130

Cover flange-mounted surface with sealing compound Loctite.
Screw in two adjusting screws and place the differential carrier against the axle housing until contact is obtained.

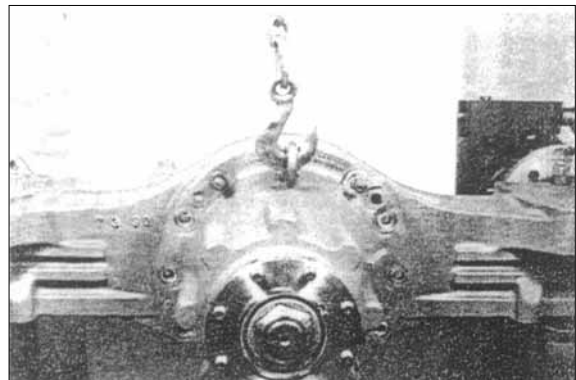

AX131

Fasten differential carrier on the axle housing by means of hexagon head screws.

- ※ Cover hexagon head screws with sealing compound Loctite.

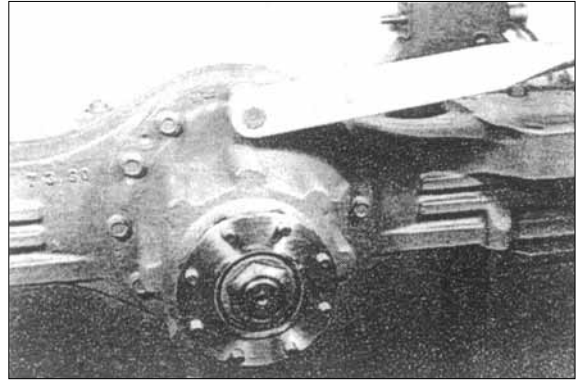

AX132

- ※ Now, install the stub shafts again and complete the final drive.
Before the axle is put into service, pay attention to the lubrication instruction, page 3-250.

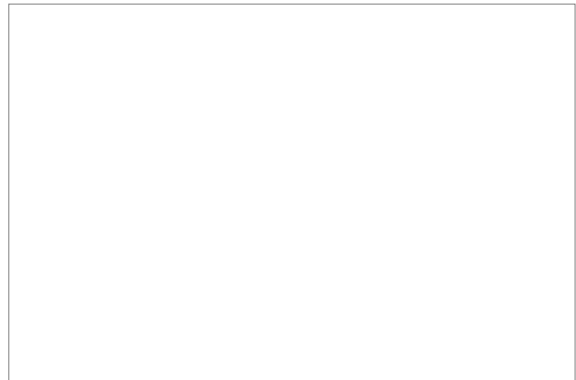

3) LUBRICATION INSTRUCTIONS

The basis for a correct lubrication of all axles and their parts is a horizontal plane of installation in every direction. (An inclined position of the differential carrier up to 5° is tolerable).

Place the machine in a horizontal position. All lubricating points must be cleaned carefully before refilling.

Drain oil only immediately after a longer run.

(1) Oil level

1. Wheel end : Turn wheel hubs until the word "Ölstand" can be read in a horizontal position. Fill up oil to the overflow on the level plug.
2. Axle housing : Fill up oil, to the overflow on the level plug or the oil filler opening respectively, installed in the center(SAE 80W-90LSD/API GL-5).
3. Differential carrier, not installed in a axle : Fill up oil 20mm below the middle of the crown wheel.

(2) Check

After a few minutes, if oil level has dropped fill up to the correct level until level remains constant. Oil level check monthly. Especially before you start a vehicle with new or repaired axles or their components respectively.

(3) Oil change

1st oil change after 200 operating hours. Further oil changes must be made every 1000 operating hours, or at least once a year.

(4) Brake

For the pneumatic-hydraulic or memory controlled brake actuation are admitted :

1. Motor oils SAE 10W according to specifications MIL-L-2104C, MIL-L-46152, API-CC, CD, SC, SD, SE, SF
2. ATF-oils(Type A/Suffix A, Dexron IID)

※ **Other brake fluids may be not used.**

(5) Points of grease lubrication

At greasing points, use a multi-purpose grease with following properties : Lithium soap, drop point 170C, NLGI class 2. The grease must be anti-corrosive, water-resistant and work stable.

Regrease all pressure grease fittings monthly.

(6) Important notes

Check correct torque limit of all screwed joints within regular intervals.(First check after 50 operating hours.)

Axles with multi-disk self-locking differentials : A slight noise could be noted, when oil without limited slip additives have been filled in. This noise can be regarded as harmless. In case of a heavy noise or when the tire is jerking, use EP-gear lubricants with Limited-Slip additives.

6) EXAMPLES OF CONTACT PATTERNS FOR THE GLEASON GEAR-TOOTH SYSTEM

(1) Coast side(Concave)

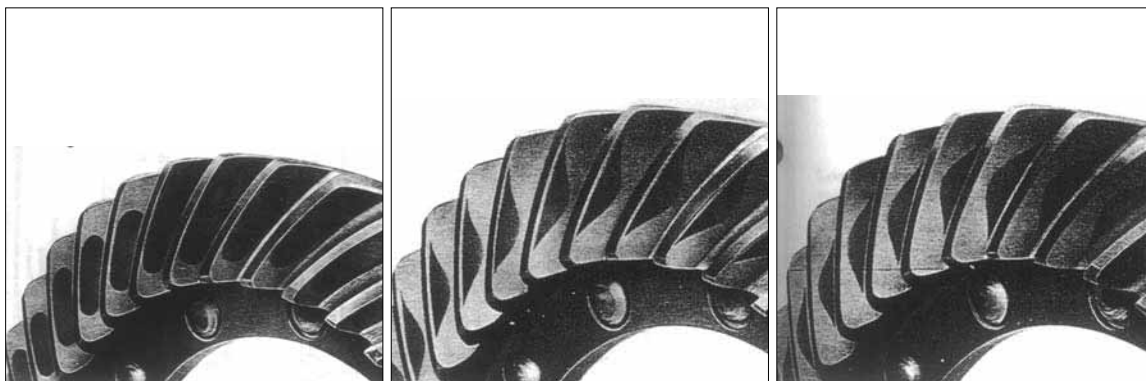

(2) Drive side(Convex)

