

SECTION 2 ENGINE



| | |
|--|------|
| Group 1 Structure and Function | 2-1 |
| Group 2 Engine fault code information(For QSM11) | 2-14 |

SECTION 2 ENGINE

GROUP 1 STRUCTURE AND FUNCTION

1. STRUCTURE

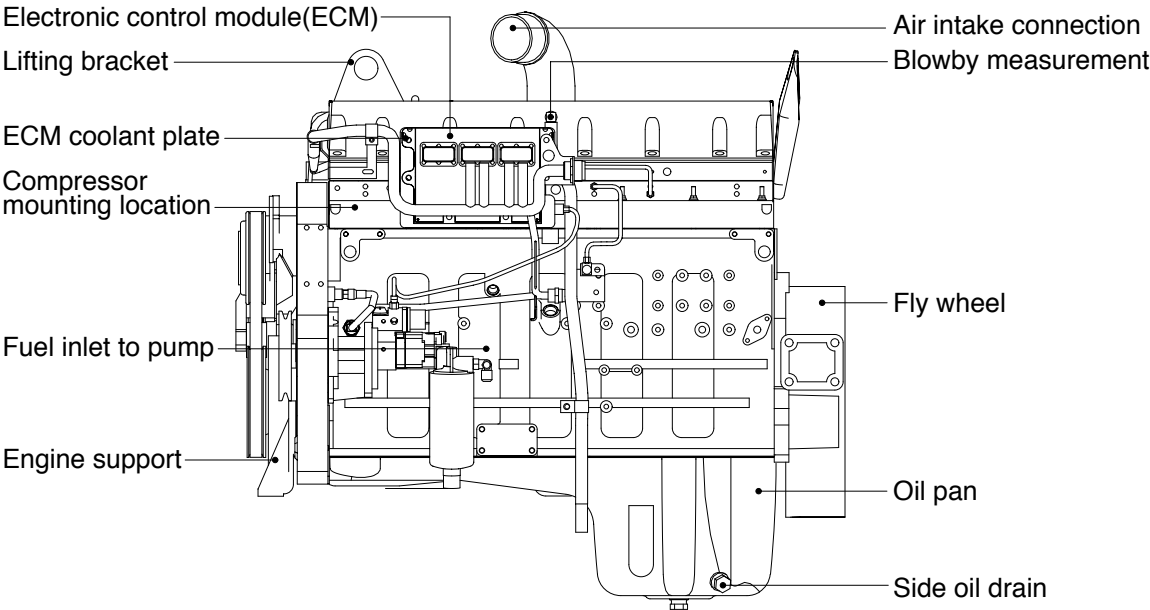
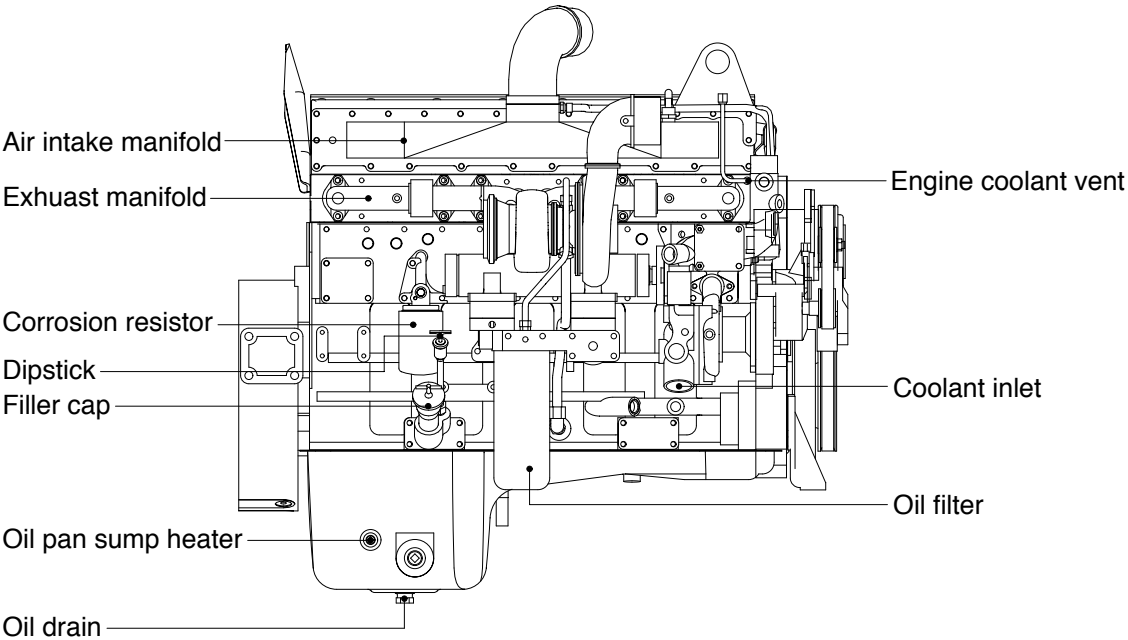

- Direct 4-stroke, 6-cylinders, water-cooling and charge air cooled diesel engine in installed, cylinder block and cylinder head are made of case iron and turbocharger is attached.

2. COMPONENTS

1) The ECM receives information from various components in the QSM system.

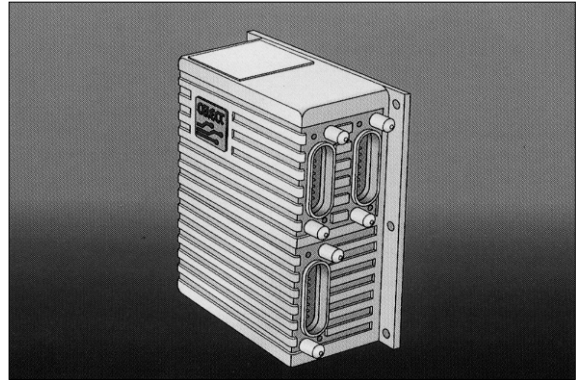

2) The temperature sensors are a two-wire type sensor with a 5 volt supply and signal return. The ECM registers temperature changes as the voltage drops across this circuit.

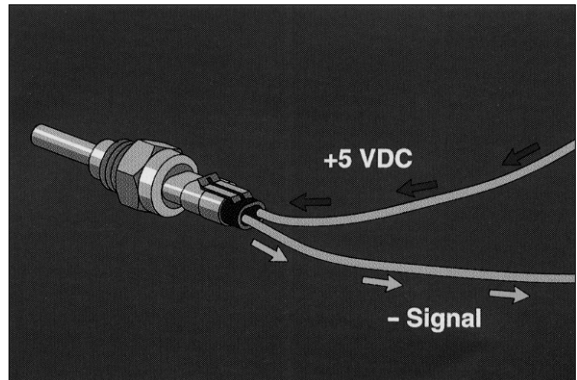

3) The Coolant Temperature Sensor is mounted in the thermostat housing. Its input is required to properly control engine timing, and to control the operation of the fan clutch. This sensor also provides input to the engine protection system.

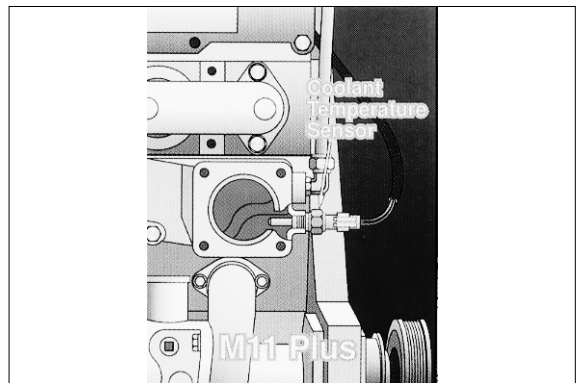

4) The Intake Air Temperature Sensor is mounted on the rear of the intake manifold. Its input is required by the engine protection system, as well as for engine control purposes.

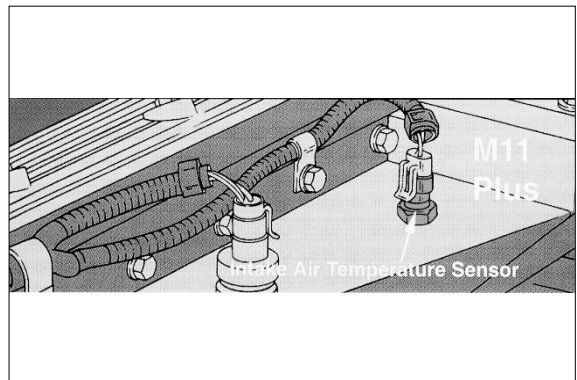

- 5) The Oil Temperature Sensor is mounted in the main oil rifle. It provides input to the engine protection system.

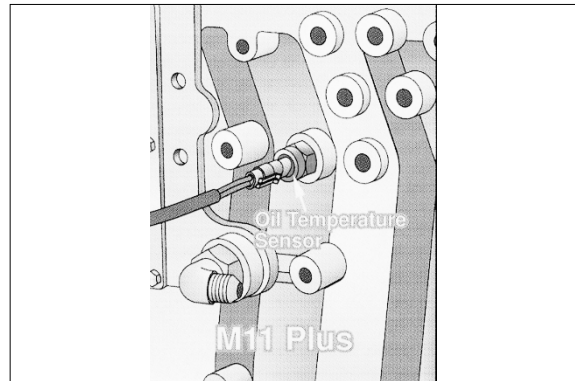

- 6) The Engine Position Sensor, or EPS, is a magnetic pick-up type device that uses the detection of 24 specially machined surfaces, on the back side of the camshaft gear, to monitor engine speed.

A unique "tooth" indicates number one cylinder at top dead center compression stroke, for injection timing purposes.

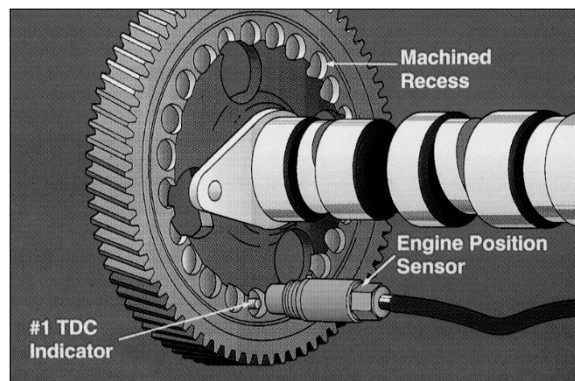

- 7) The pressure sensors are a three-wire type sensor with a 5 volt supply, a signal wire, and a return. Although pressure sensors use an analog signal similar to the temperature sensors, the electronics built into the sensor require that separate signal and return wires be used.

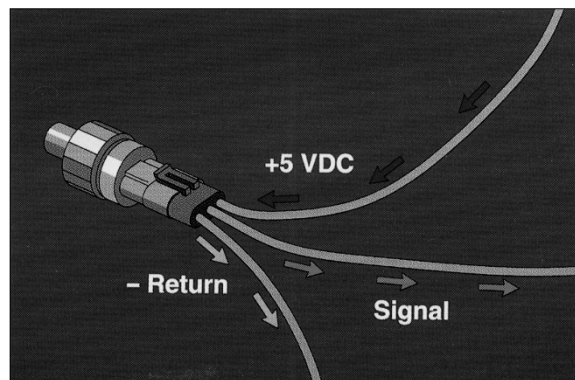

- 8) The oil Pressure Sensor is mounted in the main oil rifle. Like the oil temperature sensor, it provides input information to the engine protection system.

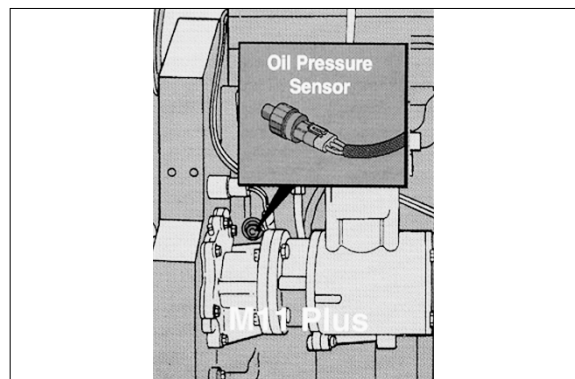

9) The Boost Pressure Sensor is mounted next to the intake manifold temperature sensor. Its input is crucial to the precise electronic control of fuel metering.

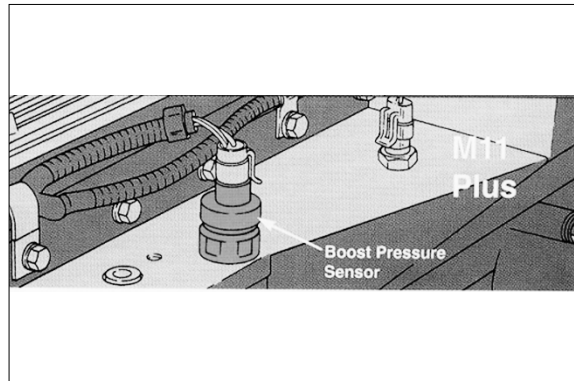

10) An Ambient Air Pressure sensor provides altitude input information to the ECM for altitude derate purposes.

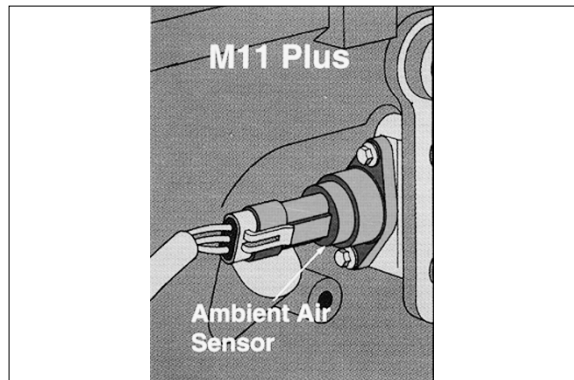

11) The vehicle Control Data Link Connector provides a means of connecting the QSM system with other onboard microprocessor-based systems, such as an anti-skid braking system.

This connector, however, is not designed to be used with a diagnostic tool such as INSITE. INSITE and other diagnostic tools should only be connected to the Service Data Links located on the OEM Harness or the Service Data Link mounted on the engine next to the ECM.

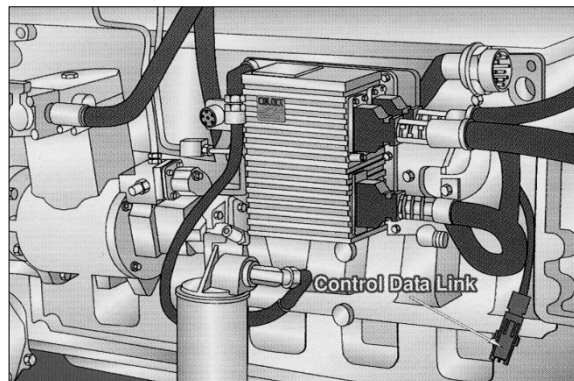

12) Engines with QSM systems will have a service data link mounted next to the ECM. This additional data link was added because new calibration procedures require that the key switch must be off during calibration transfer. But many OEM harnesses have a small amount of voltage across the data link connection even with the key off.

The OEM harness data link can be used for all service tool operations except transferring calibrations. **Only the engine-mounted data link should be used for calibration transfer.**

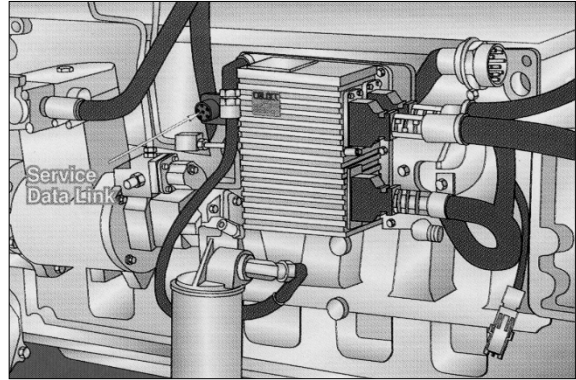

13) A 21-pin OEM connector is part of the Engine Harness. The keyswitch, diagnostic switch, coolant level sensor, fan control signals, and data link wires pass through the Engine Harness and the OEM connections.

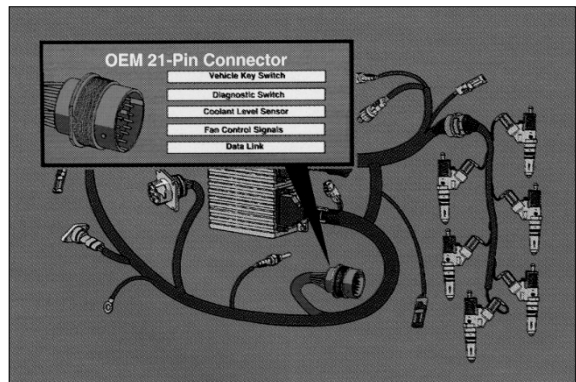

14) The throttle pedal assembly is supplied by the OEM. This assembly includes a base plate, dual return springs, idle validation switch, foot pedal, wiring harness, and a potentiometer, or "pot".

No mechanical linkage exists between the foot pedal and the engine.

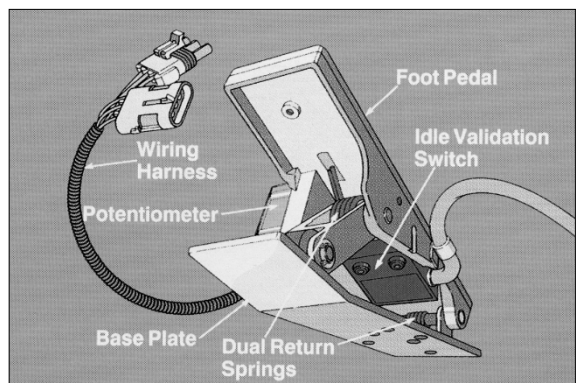

15) The potentiometer provides a DC voltage signal proportional to pedal angle displacement.

The ECM sees this voltage signal as an indication of throttle position.

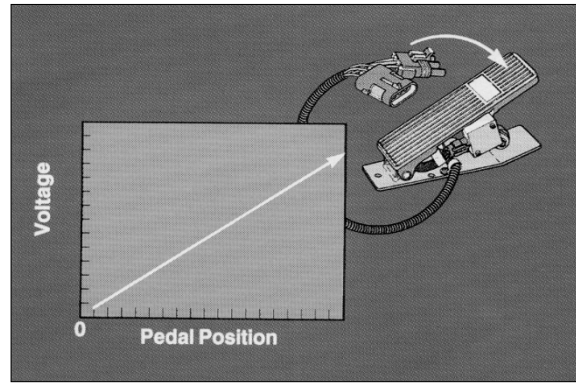

16) The Idle Validation Switch provides verification independent of throttle pot movement that the pedal is, or is not, in the idle position. This scheme allows the ECM to detect potential throttle assembly problems. The Idle Validation Switch can be a separate mechanical or an integrated switch with the potentiometer.

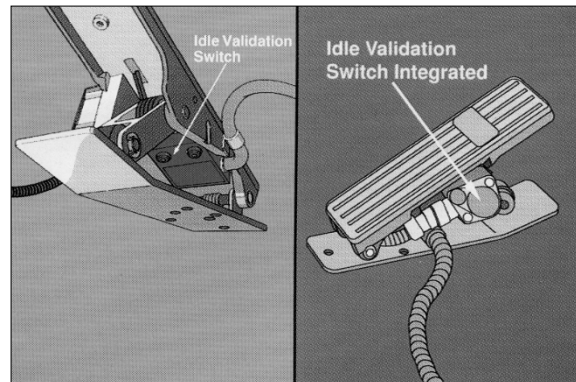

17) The tachometer output-signal connector can provide the engine RPM signal to the vehicle tachometer.

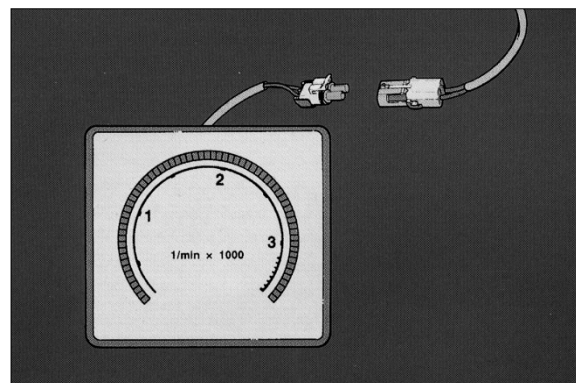

18) In this section we'll review the major components of the QSM Hydromechanical Subsystem.

The QSM system fuel supply pump is mounted to the air compressor assembly and, like the air compressor, is driven by the engine through the accessory drive.

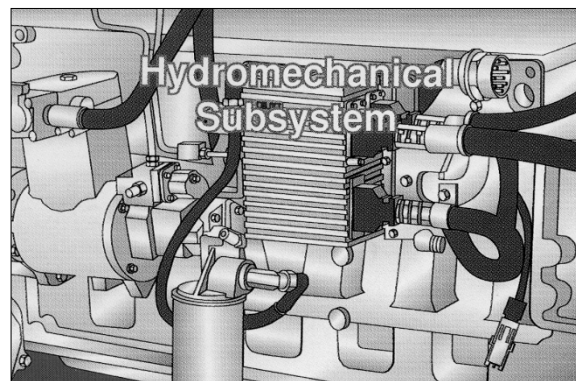

19) It's a gear-type pump, using one-and-a-quarter-inch gears.
The pressure regulator is set at approximately 150 psi.

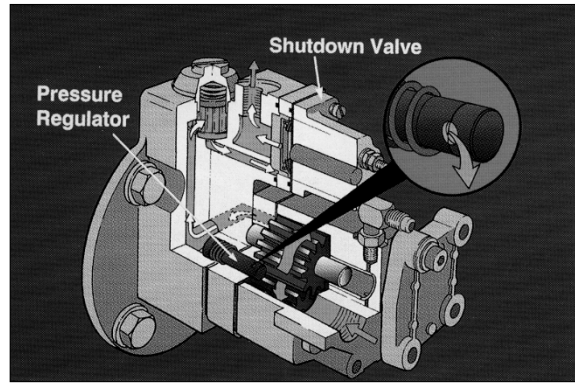

20) The ECM is mounted on a cooling plate.
During engine operation, fuel circulates through the one-pass unit, absorbing heat generated by the ECM electronics.

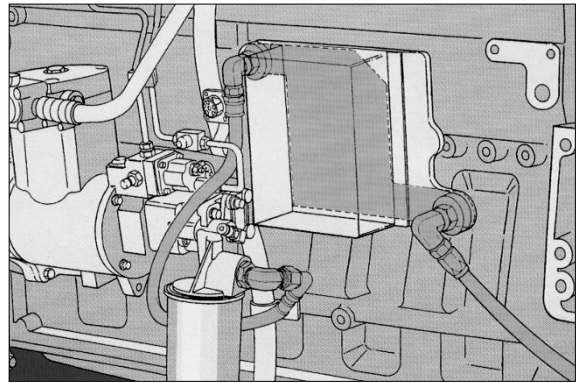

21) The electronically controlled injector is substantially different from standard PT injectors. The most apparent difference is the addition of a solenoid valve near the top of the injector.

Controlled by the ECM, it determines the amount of fuel metered, as well as injection timing.

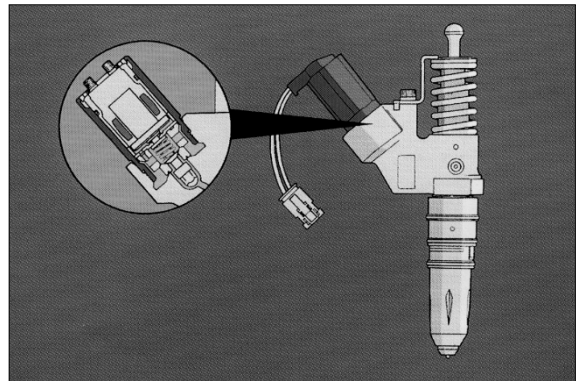

22) As mentioned earlier, the QSM injector uses camshaft actuation to build adequate pressure for injection.

- Lower Overhead Force and Cam Stress
- Improved Injection Train Component Life
- Shorter Heat Release during Combustion
- Lower Emissions
- Improved Fuel Economy

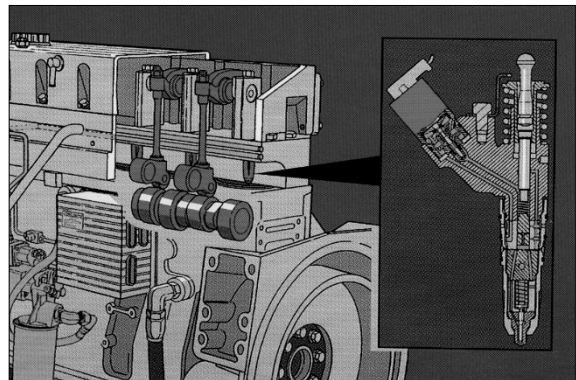

23) The QSM injector includes the top stop shim; injector control valve; spring guide; timing chamber; bias spring; metering plunger; pressure relief valve; closed nozzle subassembly, with its cup, needle valve and return spring; metering check valve; metering spill port; fuel drain passage; fuel supply passage; timing plunger; bottom stop shim; return spring; and the top stop assembly.

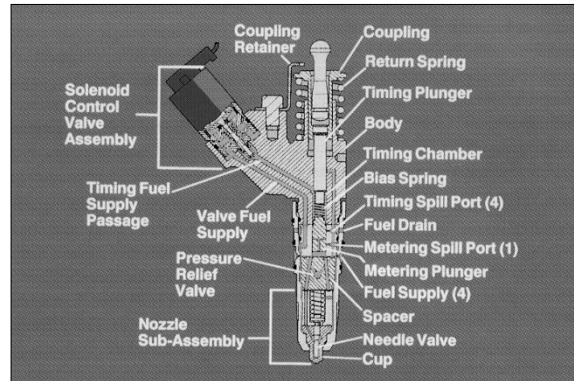

24) To better understand the operation of the injector, let's study a simplified version.

Here we can see the timing plunger, top stop hardware, return spring, injector control valve, metering spill port, pressure relief valve, fuel supply passage, metering check valve, closed-nozzle subassembly, metering plunger, bias spring, timing spill port, and the bottom stop shim.

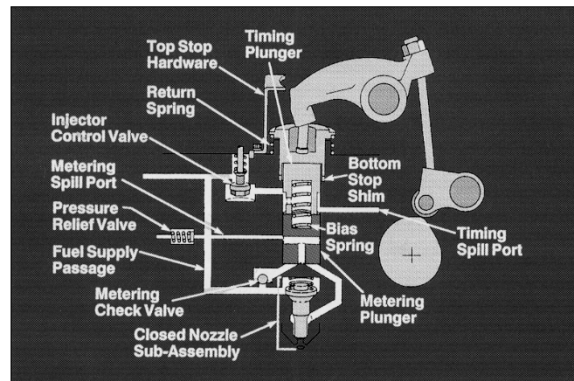

25) At the start of metering, the metering plunger and the timing plunger are at the lower limits of their travel. The injector control valve is closed.

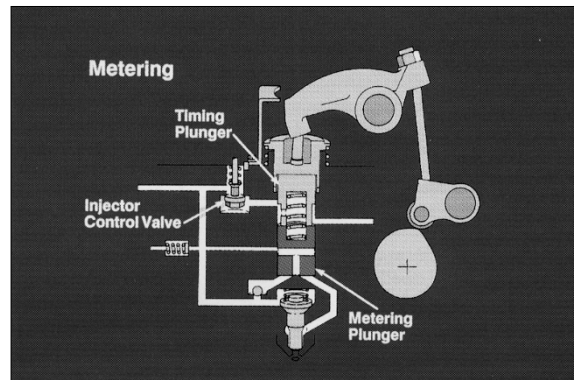

26) As the camshaft rotates, the timing plunger return spring forces the timing plunger upward.

Fuel flows past the metering checkball and into the metering chamber. This flow continues as long as the timing plunger is moving upward, and the injector control valve is closed.

Supply pressure, acting on the bottom of the metering piston, forces it to maintain contact with the timing plunger.

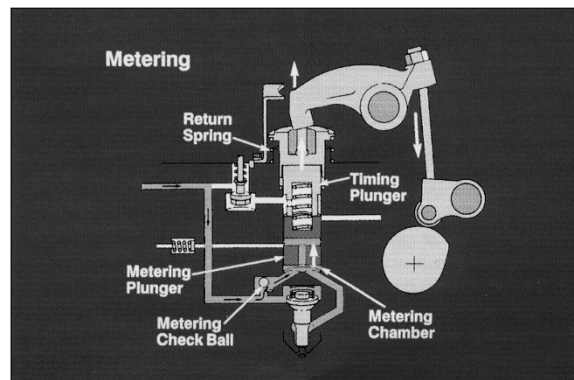

27) The ECM determines the end of metering by signaling the injector control valve to open.

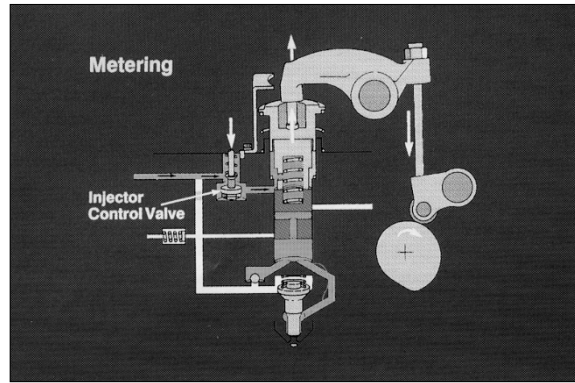

28) Fuel at supply pressure then flows into the timing chamber, thereby stopping metering-piston travel.

During this time, the bias spring ensures that the metering plunger remains stationary, that it does not drift upward as the timing plunger moves upward. This same force against the metering plunger results in enough fuel pressure below the piston to keep the metering check ball seated.

A precisely metered quantity of fuel is now trapped in the metering chamber. This determines the quantity of fuel that will be injected.

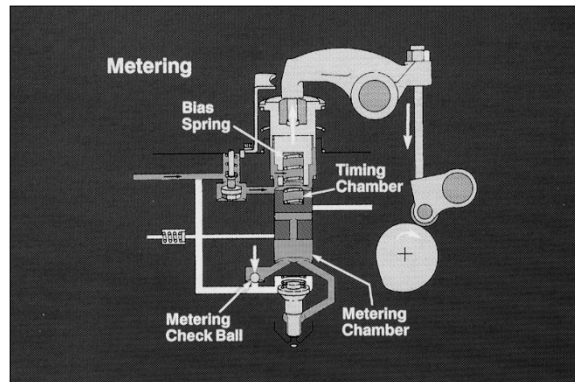

29) The timing plunger continues to move upward, and the timing chamber fills with fuel.

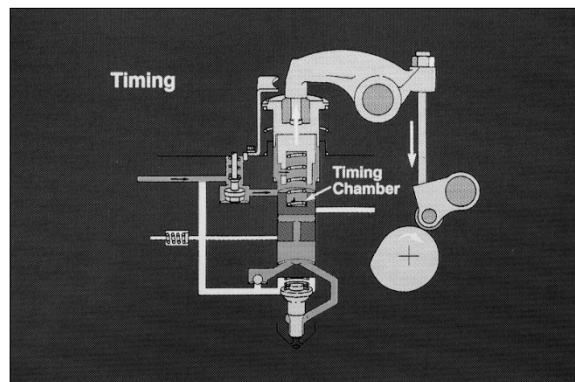

30) Now the timing plunger begins its downward travel. Initially, the injector control valve remains open, allowing fuel to flow from the timing chamber, through the injector control valve, to the fuel supply passage.

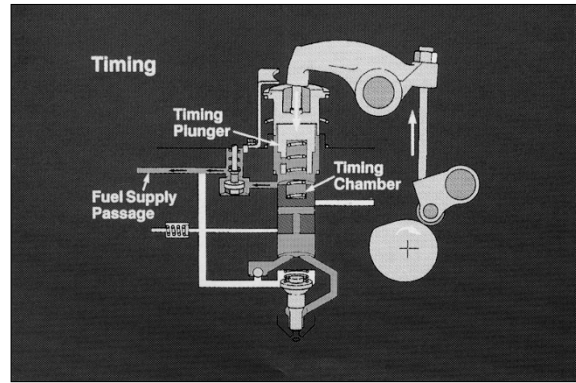

31) At the appropriate time, as determined by the ECM, the injector control valve closes, trapping fuel in the timing chamber. This trapped fuel acts as a solid hydraulic link between the timing plunger and metering plunger.

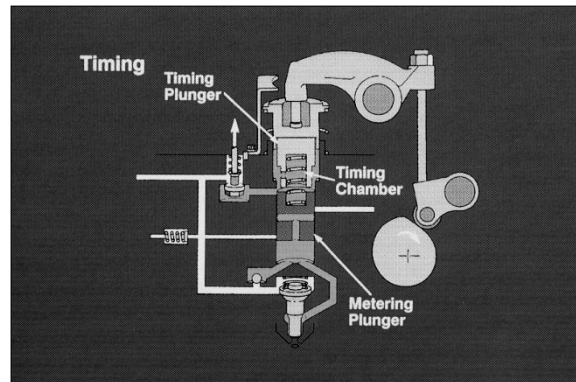

32) As a result, the metering plunger is forced to move down-ward with the timing plunger.

Because the fuel is trapped, the downward force on the timing plunger is transferred to the metering plunger, thereby increasing pressure in the metering chamber.

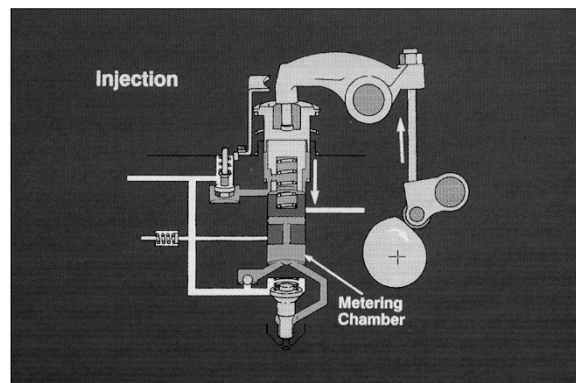

33) When this pressure reaches approximately 5000 psi, the needle valve begins to be forced upward.

Continued downward movement of the timing plunger and metering plunger results in steadily increasing fuel pressure. The result is that fuel is forced past the needle valve, through the spray holes, and into the combustion chamber.

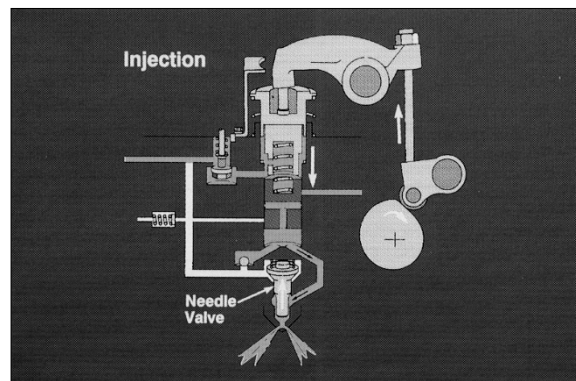

34) Injection continues until the spill passage of the metering plunger passes the metering spill port.

Metering-chamber pressure drops rapidly, allowing the needle valve to close abruptly. This action results in a positive end of injection. The positive end of injection prevents dribble, and results in cleaner burning.

It is also at this point that the pressure relief valve "pops off" thereby reducing the effects of the high pressure "spike" that occurs at the time of metering spill. The relief valve passage connects to the fuel drain line.

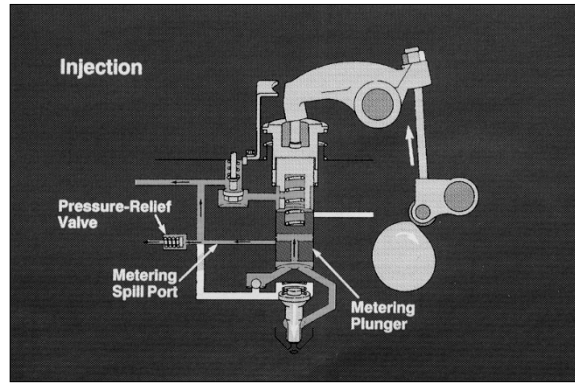

35) Immediately after the metering spill port is opened, the upper edge of the metering plunger passes the timing spill port.

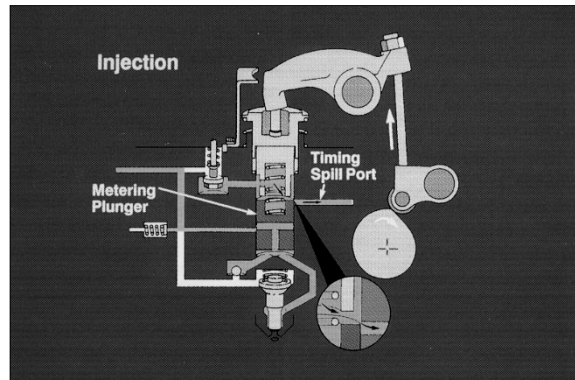

36) This action allows the fuel in the timing chamber to be spilled back to the fuel drain as the timing plunger completes its downward movement.

This completes the injection cycle.

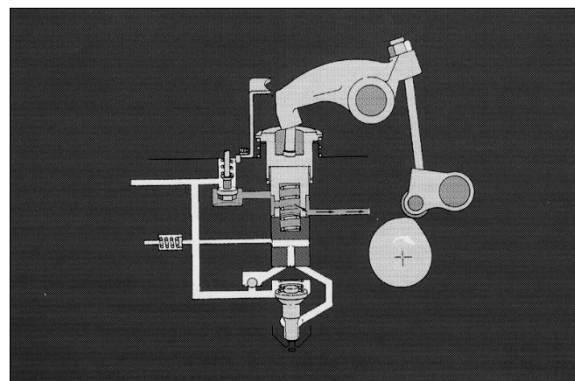

37) To summarize QSM system operation, the injector is camshaft-actuated to achieve high pressures.

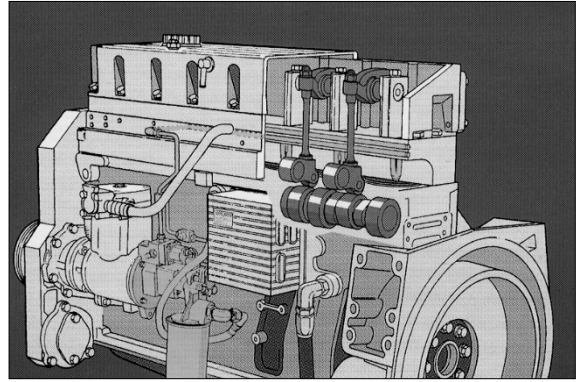

38) Opening the injector control valve terminates metering, which results in a precise amount of fuel to be injected.

Closing the injector control valve controls the start of injection. This injection "timing" can be varied over a wide range of values.

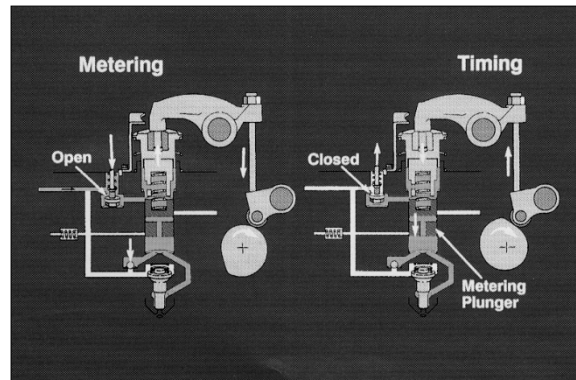

39) By varying the amount of time the injector control valve remains open, and remains closed, the ECM is able to maintain precise and independent control of metering and timing values. This process allows the system to meet engine demands resulting from a wide range of operating conditions.

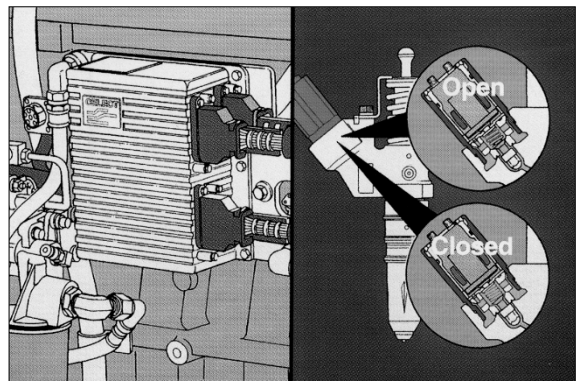

40) When fuel pressure exceeds that of the needle valve return spring, the needle valve opens and injection begins.

Injection ends when the pressure drops to less than this opening pressure.

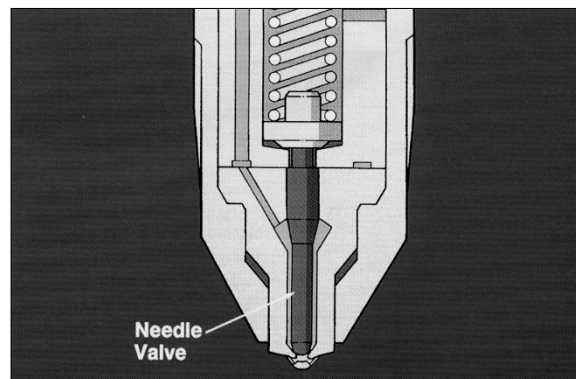

41) The primary diagnostic tool for use with the QSM system will be the INSITE computer based diagnostic tool.

Echek and Compulink cartridges will be available for use with QSM.

