

SECTION 4 BRAKE SYSTEM

Group 1	Structure and Function	4-1
Group 2	Operational Checks and Troubleshooting	4-29
Group 3	Tests and Adjustments	4-37
Group 4	Disassembly and Assembly	4-39

SECTION 4 BRAKE SYSTEM

GROUP 1 STRUCTURE AND FUNCTION

1. OUTLINE

- ※ **The brakes are operated by a pressure compensated, closed center hydraulic system. Flow is supplied by a fixed displacement, gear type brake pump.**

BRAKE SYSTEM

The fixed displacement brake pump supplies flow to the cut-off valve for service brake circuit and park brake circuits. It flows to four accumulator. The accumulator has a gas precharge and an inlet check valve to maintain a pressurized volume of oil for reserve brake applications.

Oil through the accumulator flows to the brake valves. The brake valve is a closed center design, dual circuit operated by a pedal.

The front and rear brakes will operate simultaneously with only one brake pedal depressed.

The differential contains annular brake piston and double sided disk.

Brake pump flow also goes to the parking brake solenoid valve.

The brake system contains the following components:

- Brake pump
- Parking brake solenoid valve
- Cut-off valve
- Brake valve
- Accumulators
- Pressure switches

FULL POWER HYDRAULIC BRAKE SYSTEM

ADVANTAGES - The full power hydraulic brake system has several advantages over traditional brake actuation systems. These systems are capable of supplying fluid to a range of very small and large volume service brakes with actuation that is faster than air brake systems. Figure represents a time comparison between a typical air/hydraulic and full power hydraulic brake actuation system.

Full power systems can supply significantly higher brake pressures with relatively low reactive pedal forces. The reactive pedal force felt by the operator will be proportional to the brake line pressure being generated. This is referred to as brake pressure modulation.

Another key design feature of full power systems is the ability to control maximum brake line pressure. In addition, because these systems operate with hydraulic oil, filtration can be utilized to provide long component life and low maintenance operation.

Because these systems are closed center, by using a properly sized accumulator, emergency power-off braking that is identical to power-on braking can be achieved. These systems can be either dedicated, where the brake system pump supplies only the demands of the brake system or non-dedicated, where the pump supplies the demands of the brake system as well as some secondary down stream hydraulic device.

Another important note is that all seals within these system must be compatible with the fluid medium being used.

**Response time
Full power brake actuation VS
Air/Hydraulic brake actuation**

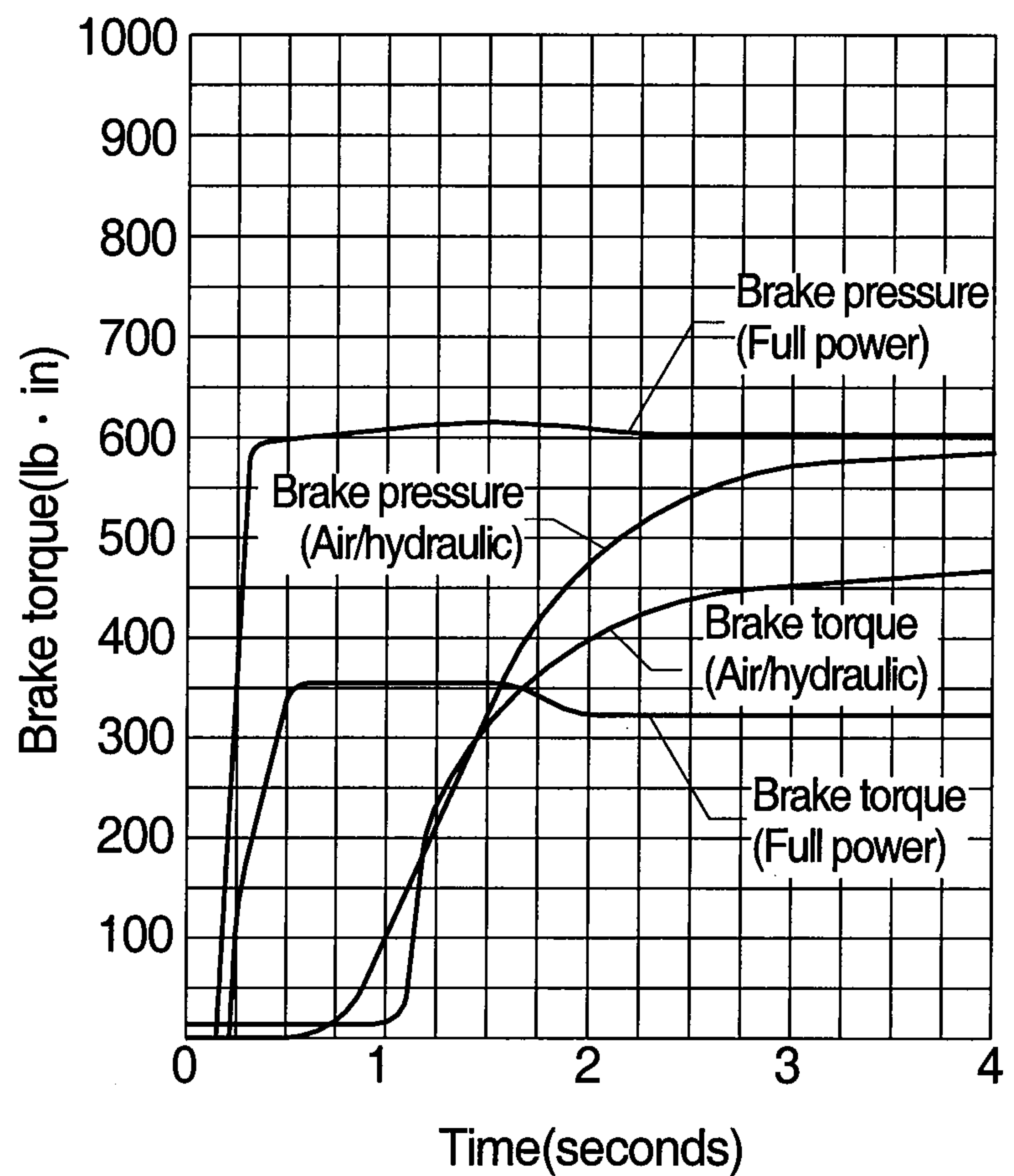

2. HYDRAULIC CIRCUIT

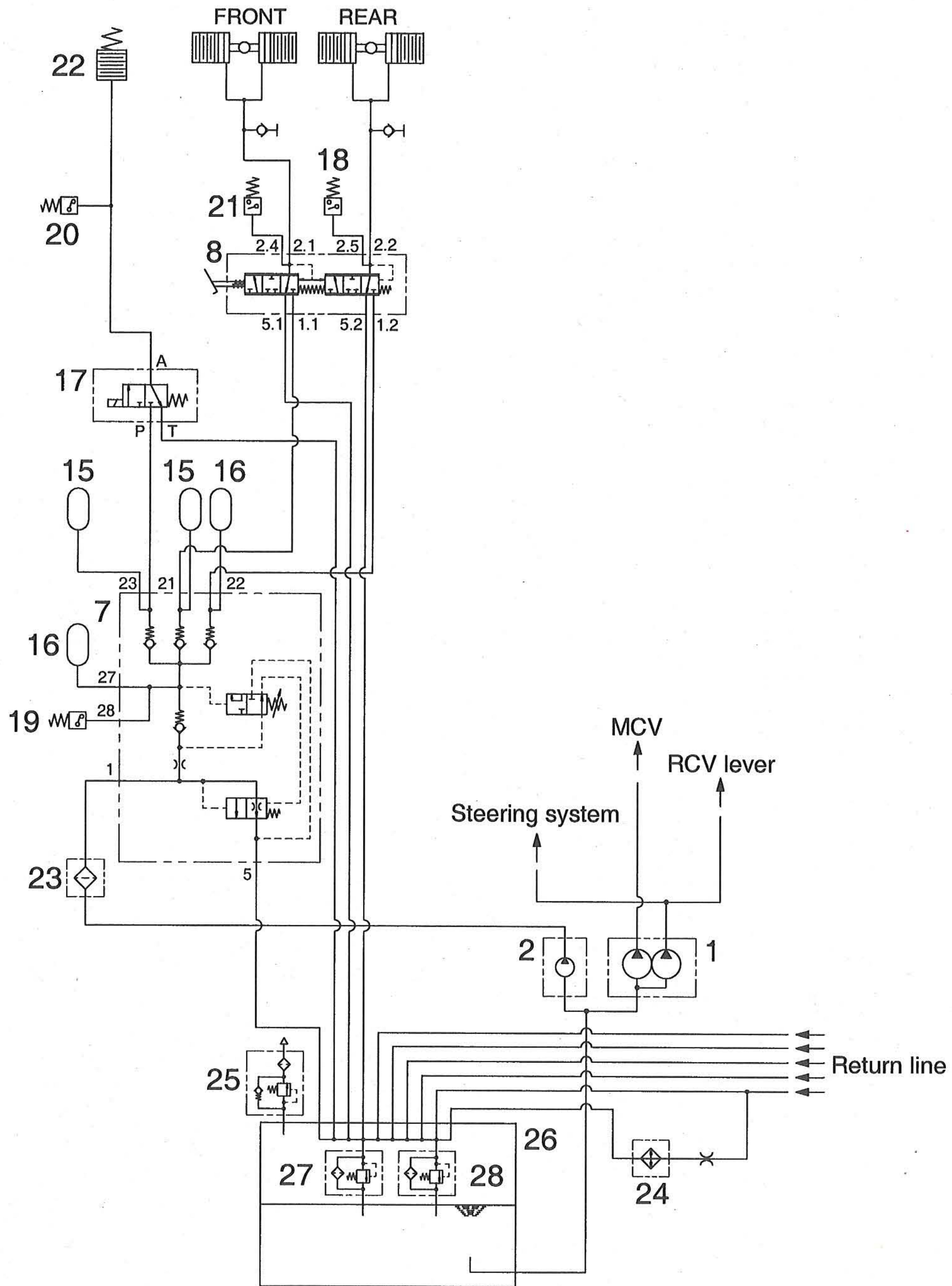

- | | | | | | |
|----|---------------|----|------------------------------|----|----------------|
| 1 | Main pump | 17 | Parking brake solenoid valve | 23 | Line filter |
| 2 | Brake pump | 18 | Pressure switch | 24 | Oil cooler |
| 7 | Cut off valve | 19 | Pressure switch | 25 | Air breather |
| 8 | Brake valve | 20 | Pressure switch | 26 | Hydraulic tank |
| 15 | Accumulator | 21 | Pressure switch | 27 | Return filter |
| 16 | Accumulator | 22 | Parking brake | 28 | Bypass valve |

1) SERVICE BRAKE RELEASED

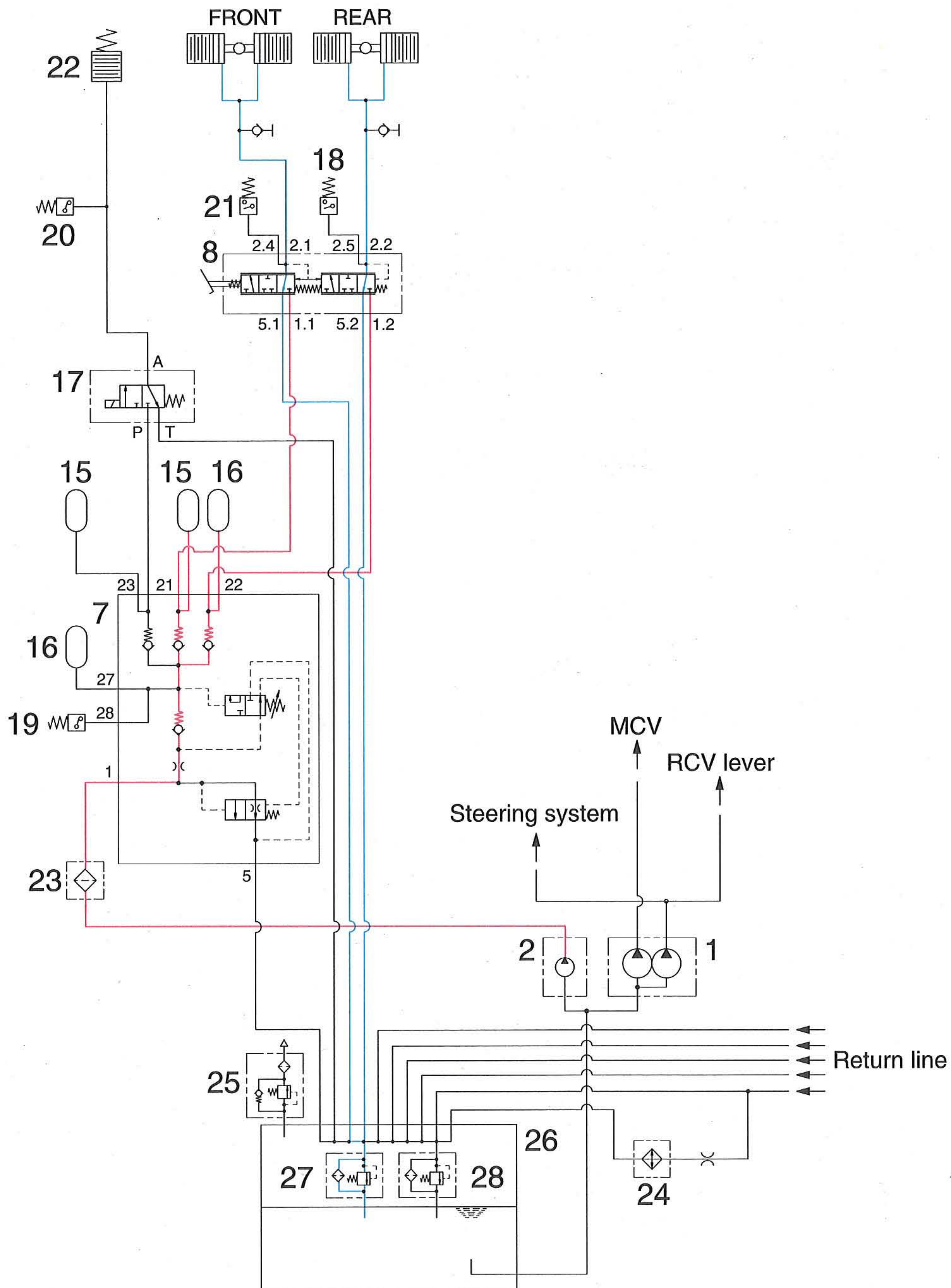

When the pedal of brake valve(8) is released, the operating force is eliminated by the force of the spring, and the spool is returned.

When the spool removes up, the exhaust port is opened and the hydraulic oil in the piston of axles return to the tank(26).

Therefore, the service brake is kept released.

2) SERVICE BRAKE OPERATED

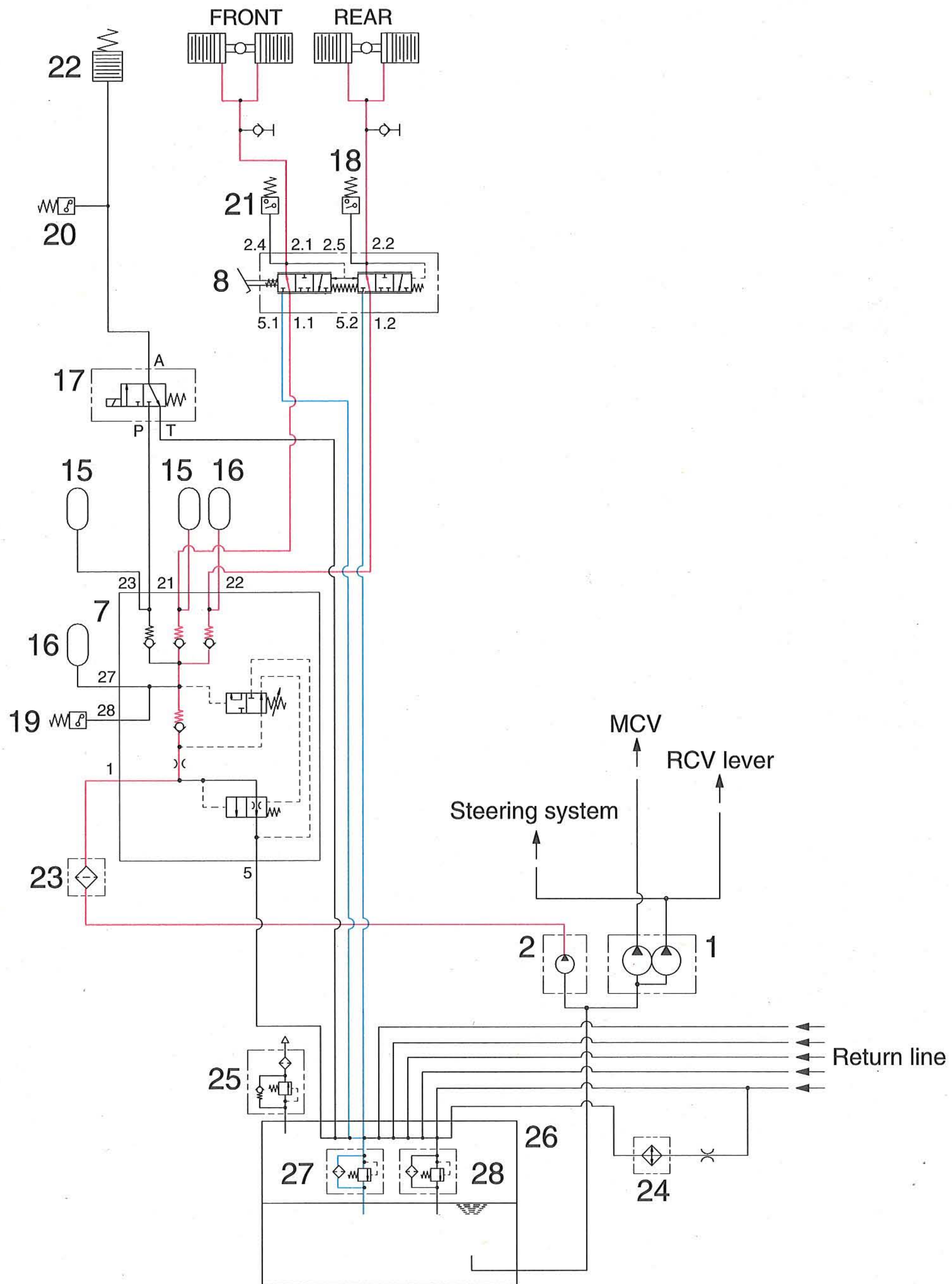

When the pedal of brake valve(8) is depressed, the operating force overcomes the force of the spring, and is transmitted to the spool. When the spool moves down, the inlet port is opened, and at the same time the hydraulic oil controlled the pressure level by the cut-off valve(7) enters the piston in the front and rear axles. Therefore, the service brake is applied.

3) PARKING BRAKE RELEASED

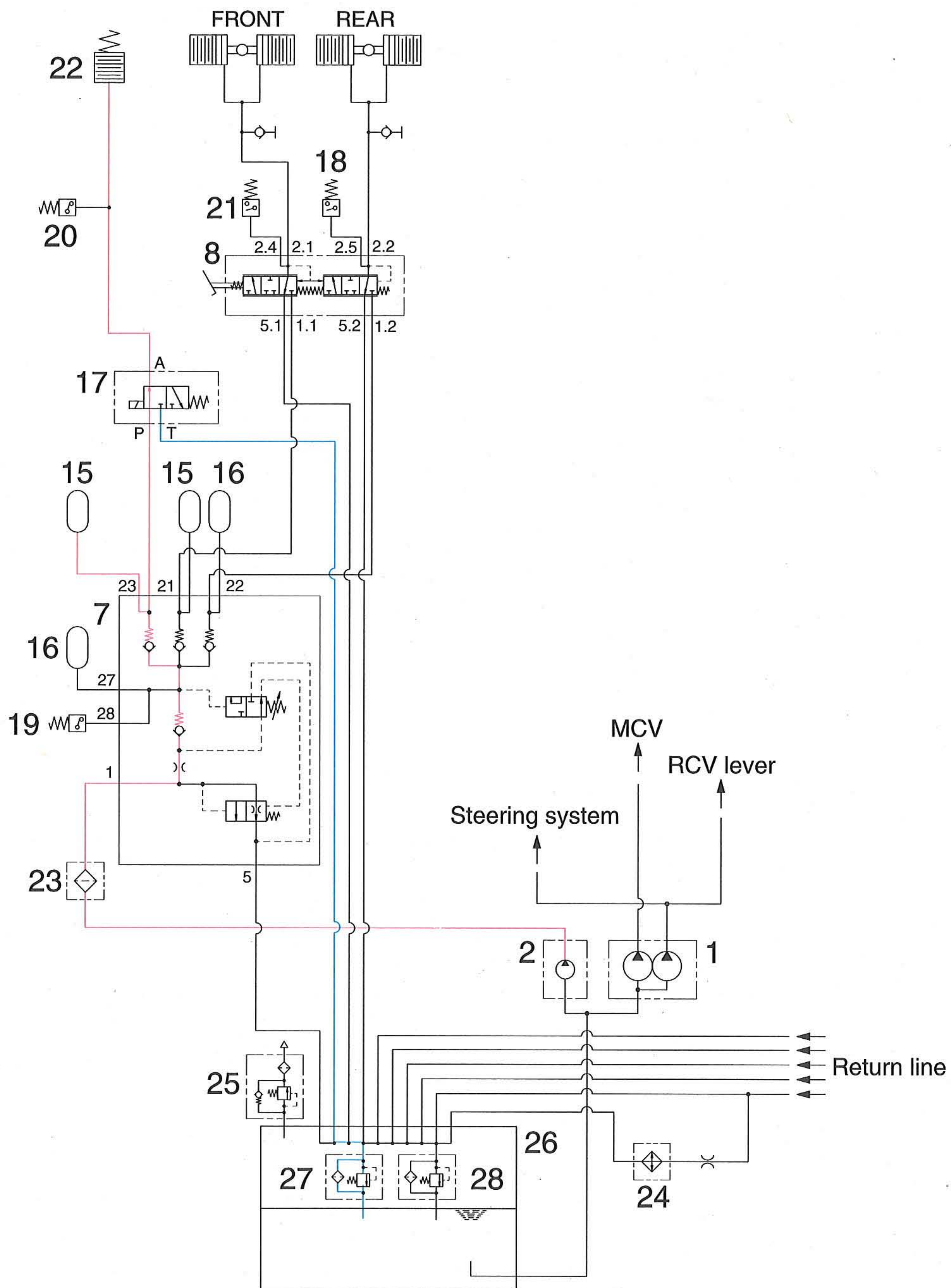

When the parking brake switch is pushed, the solenoid valve(17) is energized and the hydraulic oil controlled the pressure level by the cut-off valve(7) enters the parking brake(22) on the front axle. It overcomes the force of the spring and pushes the piston rod. This releases the brake. Therefore, the hydraulic oil pressure is applied to the parking brake piston through the solenoid valve(17) and the parking brake(22) is kept released.

4) PARKING BRAKE OPERATED

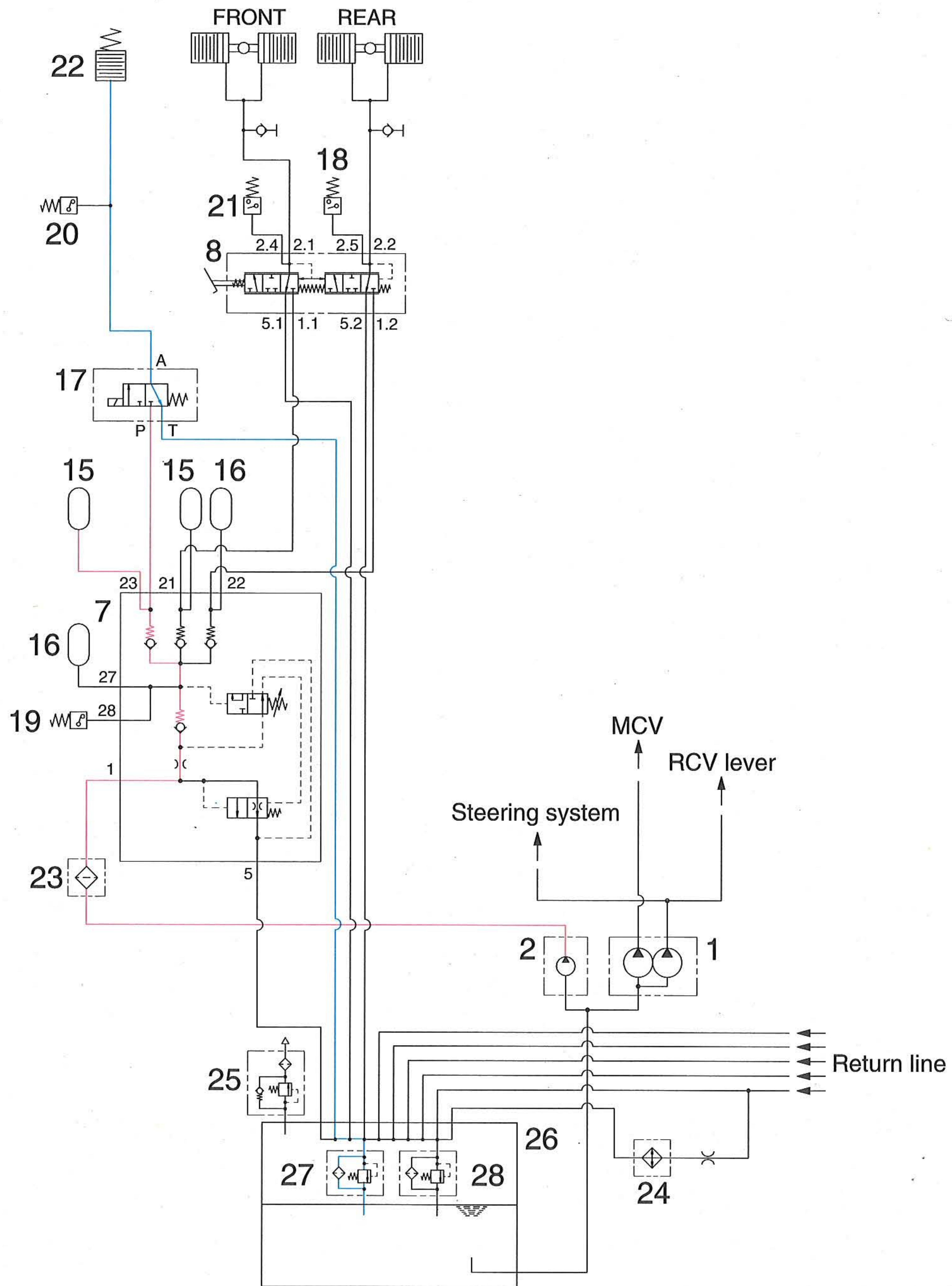

When the parking brake switch is pushed once more, the solenoid valve(17) is deenergized and the valve open the exhaust port.

At the same time, the hydraulic oil in the parking brake(22) return to the tank through the solonoid valve(17). When the piston rod is returned by the force of the spring, the parking brake is applied.

3. BRAKE PUMP

1) STRUCTURE

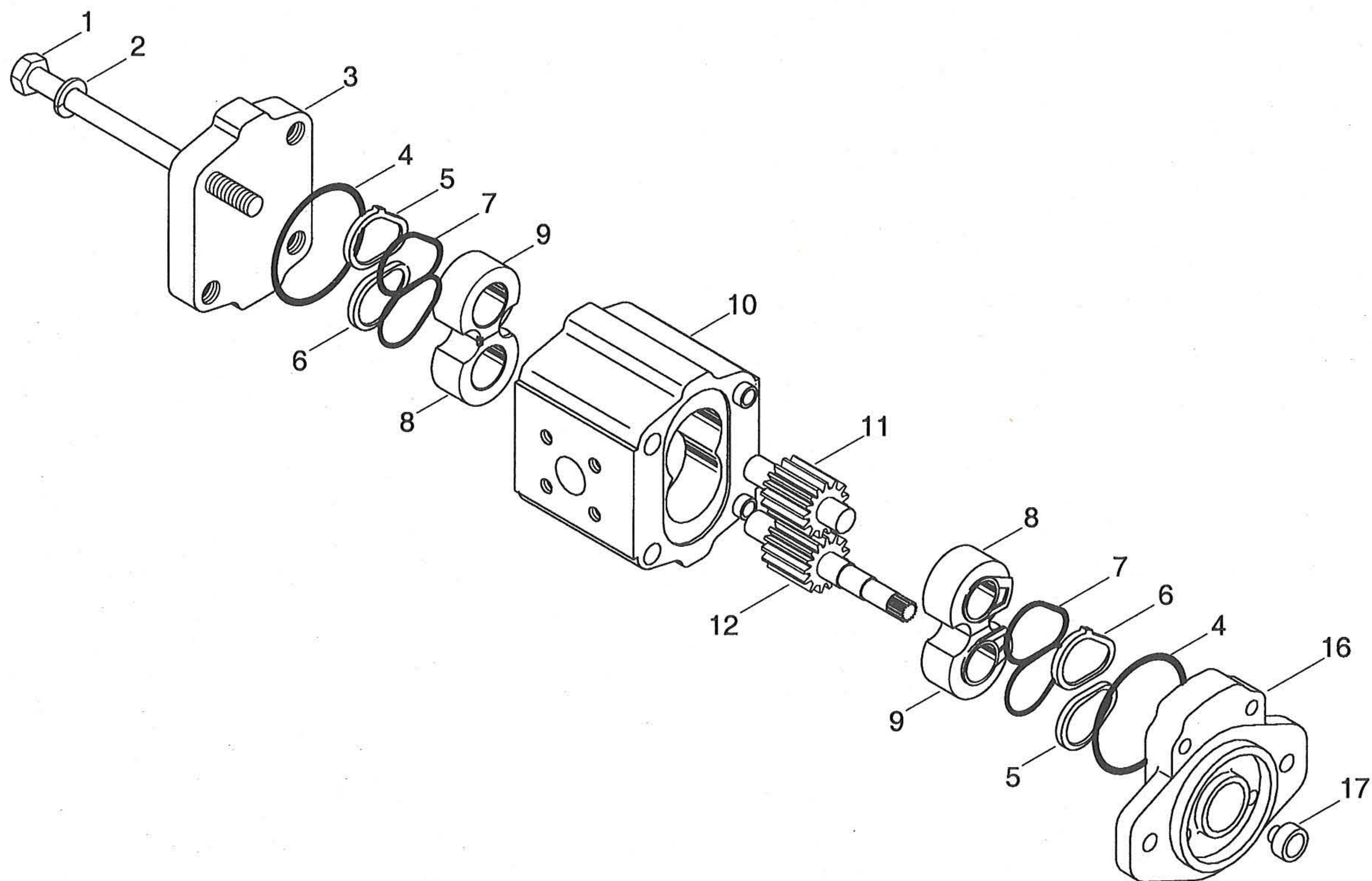

- | | | |
|-----------------|---------------------|------------------------|
| 1 Bolt | 6 Backing ring | 11 Driven gear |
| 2 Spring washer | 7 Bushing lobe seal | 12 Splined drive shaft |
| 3 End cover | 8 Bushing | 16 Mounting flange |
| 4 Body O-ring | 9 Bushing | 17 Shaft seal |
| 5 Backing ring | 10 Body | |

Hydraulic pumps used for the work equipment hydraulic units on construction machinery are pressure loaded type gear pumps. This gear pump have a maximum delivery pressure of 150kg/cm². The pressure loaded type gear pump is designed so that the clearance between the gear and the side plate can be automatically adjusted according to the delivery pressure. Therefore, the oil leakage from the side plate is less than that in the case of the fixed side plate type under a high discharge pressure. Consequently, no significant reduction of the pump delivery occurs, even when the pump is operated under pressure.

2) PRINCIPLE OF OPERATION

(1) Mechanism for delivering oil

The drawing at right shows the operational principle of an external gear pump in which two gears are rotating in mesh.

The oil entering through the suction port is trapped in the space between two gear teeth, and is delivered to the discharge port as the gear rotates.

Except for the oil at the bottom of the gear teeth, the oil trapped between the gear teeth, is prevented from returning to the suction side with the gears in mesh.

Since the gears are constantly delivering oil, the oil delivered to the discharge port is forced out of the port.

The amount of discharge increases with the speed of rotation of the gear.

If there is no resistance in the oil passage into which the discharged oil flows, the oil merely flows through the passage, producing no increase in pressure.

If however, the oil passage is blocked with something like a hydraulic cylinder, there will be no other place for the oil to flow, so the oil pressure will rise. But the pressure which rises in this way will never go higher, once the hydraulic cylinder piston starts moving because of the oil pressure. As described earlier, the pump produces the oil flow, but not the oil pressure. We can therefore conclude that pressure is a consequence of load.

In other words, the pressure depends on a counterpart.



(2) Internal oil leakage

Oil leaks from a place under higher pressure to a place under lower pressure, provided that a gap or a clearance exists in between.

In the gear pump, small clearances are provided between the gear and the case and between the gear and the side plate to allow the oil to leak out and to serve as a lubricant so that the pump will be protected from seizure and binding.

The drawing at right shows how the leaked oil flows in the pump. As such, there is always oil leakage in the pump from the discharge side (under higher pressure) to the suction side. The delivery of the pump is reduced by an amount equal to the pump discharge.

In addition, the delivery of the pump will also decrease as the amount of oil leakage increases because of expanded radial clearance resulting from the wear of pump parts, the lower oil viscosity resulting from increases in the oil temperature, and the initial use of low viscosity oil.

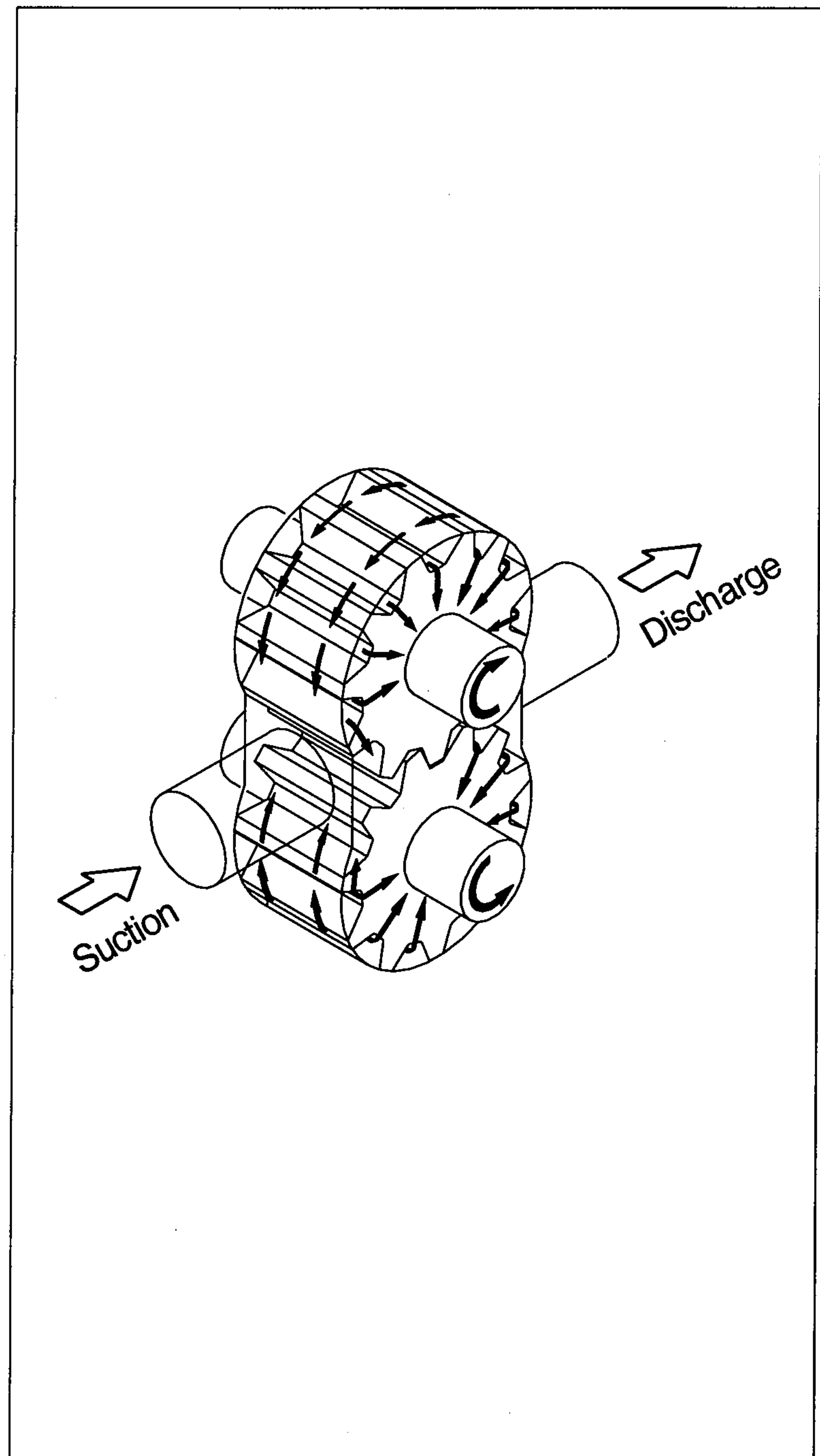

(3) Forces acting on the gear

The gear, whose outer surface is subjected to oil pressure, receives forces jointing towards its center.

Due to the action of the delivery pressure, the oil pressure is higher on the delivery side of the pump, and due to suction pressure, is lower on the suction side. In the intermediate section, the pressure will gradually lower as the position moves from the delivery side to the suction side.

This phenomenon is shown in the drawing at right.

In addition, the gears in mesh will receive interacting forces.

These forces pushing the gears toward the suction side are received by the bearings. Since the gears are pressed toward the suction side by these forces, the radial clearance becomes smaller on the suction side in the case. In some pumps, the clearance may become zero, thus allowing the gear teeth and the case to come into light contact.

For this reason, an excessive increase in the delivery pressure must be avoided, since it will produce a large force which will act on the gears, placing an overload on the bearings, and resulting in a shortened service life of the bearing or interference of the gear with the case.

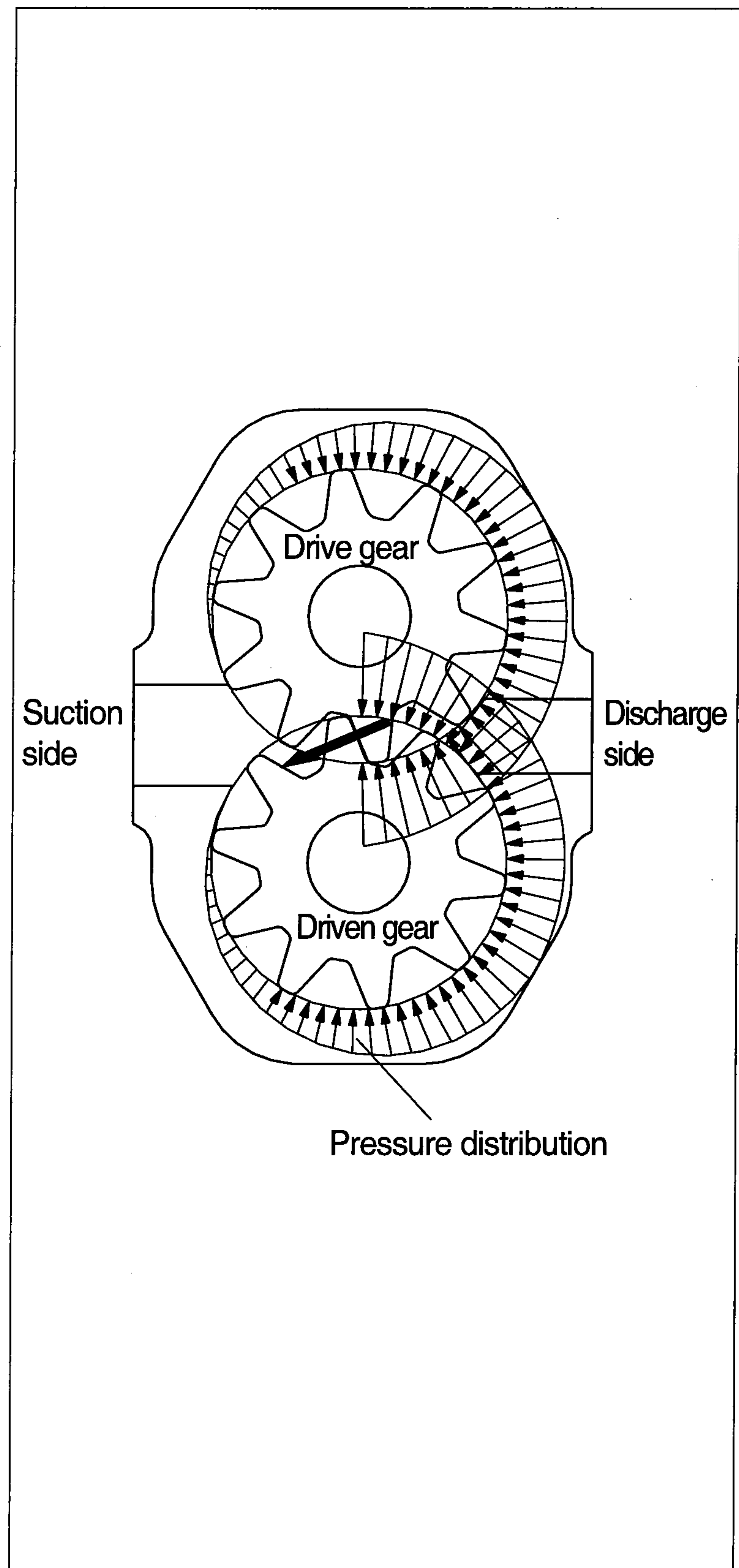

(4) "Trapping" phenomenon of the oil

When a gear pump is rotating with the gears in mesh as shown in the drawing at right, in some instances two sets of gear teeth are in mesh while in other instances only one set of the gear teeth is in mesh.

When two sets of the teeth are in mesh simultaneously, the oil in the space between the meshed gear teeth will be trapped inside-the front and rear exits will be completely shut.

This is called the "trapping" phenomenon of oil.

The space in which the oil is trapped moves from the suction side to the delivery side as the gears rotate. The volume of the space gradually decreases from the start of trapping until the space reaches the center section, and then gradually increases after leaving the center section until the end of trapping.

Since the oil itself is non-shrinkable, a reduction of the volume of space will greatly increase the oil pressure, unless some provision is made to relieve oil pressure. The high pressure oil will cause the pump to make noise and vibrate.

To prevent this, relief notches are provided on the side plates to release the oil to the delivery side.

As shown in the drawing at right, the relief notches are provided in such a way that the oil can be relieved from the trapping space to the delivery side when the volume of the space is reduced.

Relief notches are also provided on the suction side to prevent the formation of a vacuum in the space by allowing the oil to enter the space from the suction side when the space is reduced.

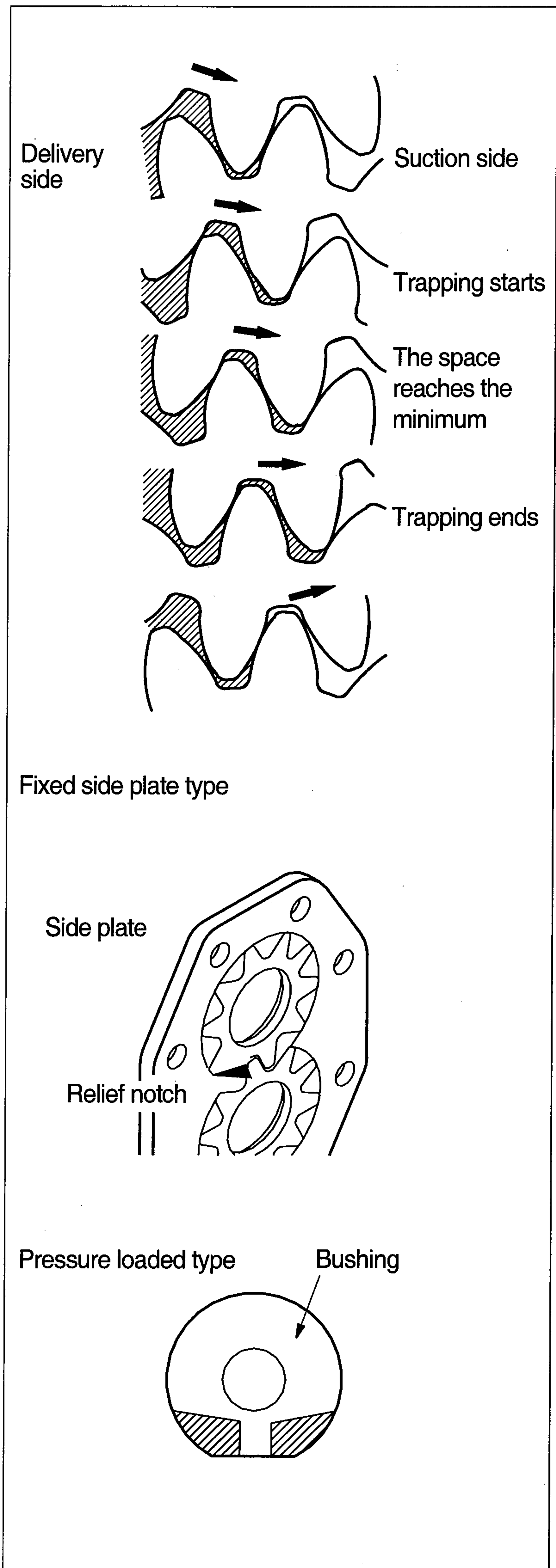

4. BRAKE VALVE

1) STRUCTURE

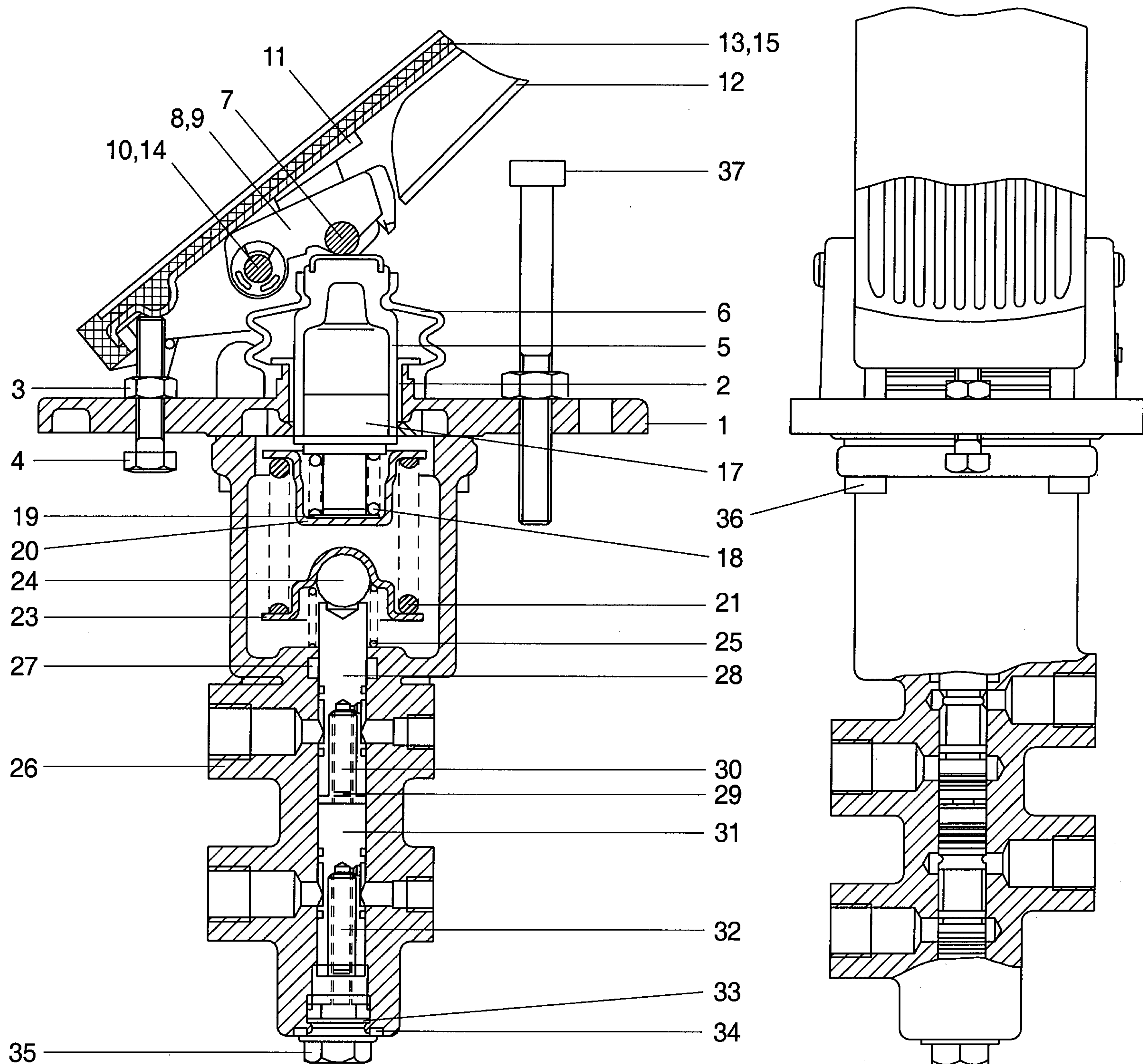

1	Base plate	13	Rivet	27	Ring
2	Bushing	14	Pin	28	Spool
3	Nut	15	Pedal cover	29	Retainer
4	Screw	17	Guide pin	30	Spring
5	Piston	18	Spring	31	Spool
6	Bellows	19	Washer	32	Spring
7	Pin	20	Cap	33	Snap ring
8	Bracket	21	Spring	34	Washer
9	Bracket	23	Cap	35	Plug
10	Retaining ring	24	Ball	36	Bolt
11	Plate	25	Spring	37	Bolt
12	Pedal	26	Housing		

2) OPERATION

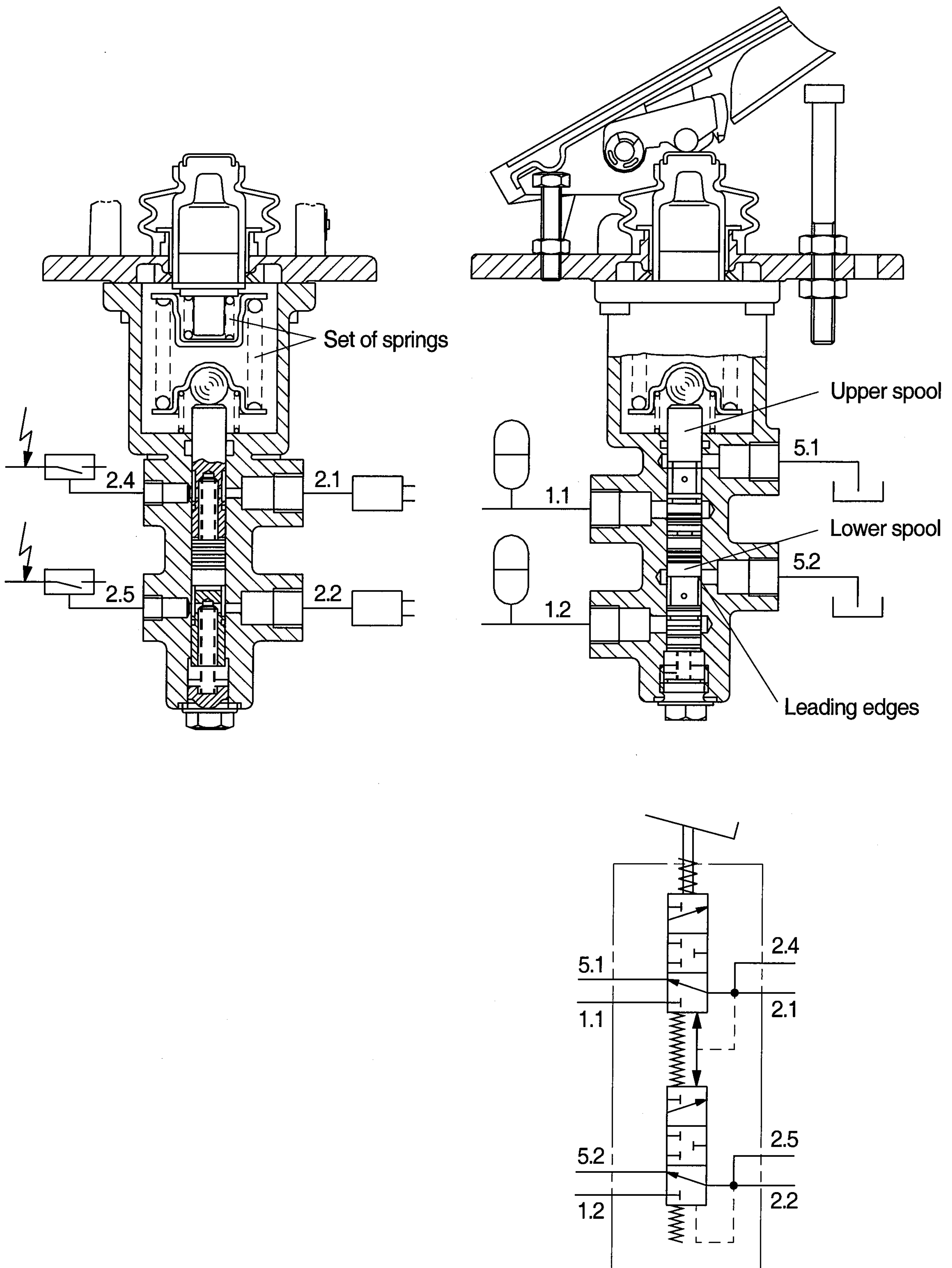

(1) Purpose

The purpose of the brake valve is to sensitively increase and decrease the braking pressure when the brake pedal is actuated.

(2) Ready position

When the braking system is ready for operation, its accumulator pressure acts directly on ports (1.1, 1.2) of the brake valve. A connection is established between ports(2.1, 2.2) and ports(5.1, 5.2) so that the wheel brakes ports(2.1, 2.2) are pressureless via the returns ports(5.1, 5.2).

(3) Partial braking

When the brake valve is actuated, an amount of hydraulic pressure is output as a ratio of the foot force applied.

The spring assembly(21) beneath base plate(1) is designed in such a way that the braking pressure changes depending on the angle. In the lower braking pressure range, the machine can be slowed sensitively.

When the braking process is commenced, the upper spool(28) is mechanically actuated via spring assembly(21), and the lower spool(31) is actuated hydraulically by spool(28). As spools (28 and 31) move downward, they will first close returns(5.1, 5.2) via the control edges, thus establishing a connection between accumulator ports(1.1, 1.2) and ports(2.1, 2.2) for the wheel brake cylinders. The foot force applied now determines the output braking pressure. The control spools(28 and 31) are held in the control position by the force applied(Spring assembly above the spools and the hydraulic pressure below the spool(Balance of forces).

After output of the braking pressure, spools(28 and 31) are in a partial braking position, causing ports(1.1, 1.2) and(5.1, 5.2) to close and holding the pressure in ports(2.1, 2.2).

(4) Full braking position

When pedal(12) is fully actuated, end end position of the brakes is reached and a connection established between accumulator ports(1.1, 1.2) and brake cylinder ports(2.1, 2.2). Returns (5.1, 5.2) are closed at this point.

When the braking process is ended, a connection is once again established between brake cylinder ports(2.1, 2.2) and return ports(5.1, 5.2), closing accumulator ports(1.1, 1.2).

The arrangement of spools in the valve ensures that even if one braking circuit fails the other remains fully operational. This is achieved by means of the mechanical actuation of both spools and requires slightly more pedal travel.

(5) Limiting the braking pressure

Pedal restriction bolt(37) on base plate(1) below pedal(12) is used to limit the braking pressure.

(6) Failure of a circuit

In the event of the lower circuit failing, the upper circuit will remain operational. Spring assembly (21) will mechanically actuate spool(28). In the event of the upper circuit failing, the lower circuit will remain operational since the lower spool(31) is mechanically actuated by spring assembly(21) and spool(28).

(7) Installation requirements

Return lines(5.1, 5.2) must be connected directly to the tank.

The connecting lines must be installed is such a way as to permit proper bleeding.

(8) Maintenance of the brake valve

No special maintenance beyond the legal requirements is necessary.

When using high-pressure cleaners on the machine, please make sure that the water jet is not aimed directly at the brake valve (To prevent damaging the bellows).

△ **For safety reasons the whole of the brake valve must be replaced if parts other than those listed above are damaged.**

(9) Repair work

△ **When working on the braking system, always make sure that there is absolutely no pressure in the system. Even when the engine is switched off there will be some residual pressure in the system.**

※ **When doing repair work, make sure your environment is very clean. Immediately close all open ports on the components and on pipes using plugs.**

(10) Replacing the pedal cover

Pedal cover(15) is simply pulled off by hand. The new pedal cover is pushed over pedal(12) and tightened manually. Fasten the bellows with the strap retainers.

(11) Replacing the complete actuating mechanism

Carefully clamp the unit vertically in a fixture. The actuating mechanism can be removed by taking out the four bolts(36) below base plate(1). Make sure that spring assembly (21) does not fall out. When installing the new actuating mechanism, make sure that spring assembly (21) is fitted in the right order. Tighten the four bolts(36).

(12) Replacing the bellows

To change bellows(6) it is advisable to remove pedal(12). For this purpose, loosen retaining ring (10) and knock out pin(14) using a mandrill. When knocking out the bolt, make sure that the mandrill is applied to the side of the bolt without a knurl. Remove pedal(12) and bellows(6).

Now fit the new bellows(6) and proceed in reverse order as described above. The upper portion of bellows(6) is fastened to piston(5), its lower portion to base plate(1) secure the bellows using clamps.

(13) Replacing the grooved ring

Carefully clamp the unit vertically in a fixture. Unscrew plug(35) and pull spool(28 and 31) out downwards. Check the spools for damage. If they are found to be damaged, the whole brake valve needs to be replaced (Pairs of spools and housings are matched in manufacturing).

If the spools are not damaged in any way, remove the whole actuating mechanism as described above. Remove spring assembly(21) and grooved ring(27) and put in a new greased grooved ring with its lips pointing downwards. Install both the spring assembly as shown in the drawing, and the pedal. Put in spring(30), followed by spool(31), using a slight turning motion if possible. Insert spring(32) and close the unit with screw plug(35).

Check return ports(5.1, 5.2) to see if there is a gap of approx. 2mm between the lower edge of the hole and the control edge of spool(28). If this is not the case, take out screw plug(35) once more and change the setting by removing or adding distance washers(19) in the upper spring plate. Replace the screw plug and once again check the distance between the lower edge of the hole at ports(5.1, 5.2) and the control edge of spool(28).

5. CUT-OFF VALVE

1) STRUCTURE

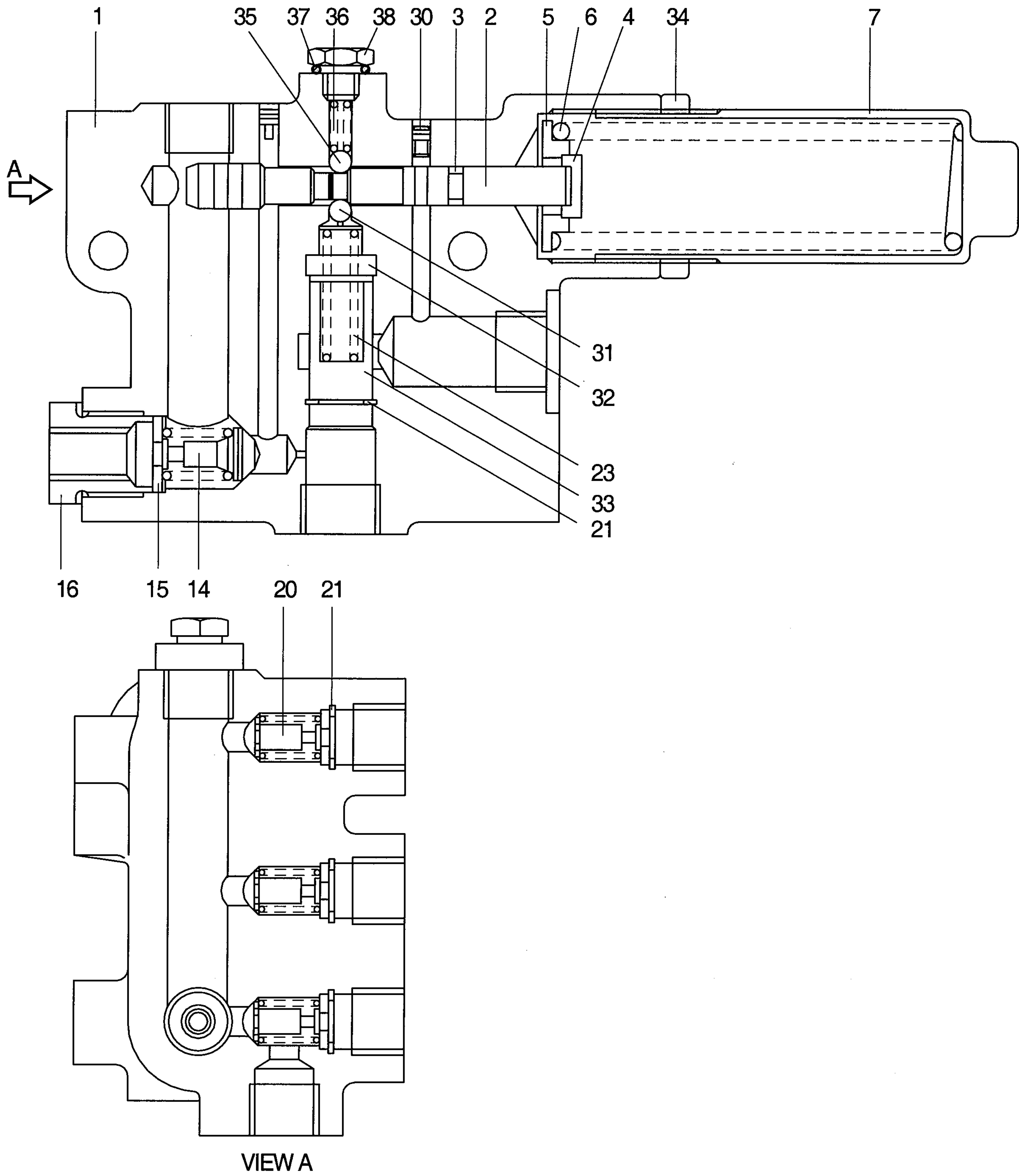

1	Housing	15	Washer	33	Spool
2	Spool	16	Screw plug	34	Nut
3	O-ring	20	Shuttle valve	35	Ball
4	Back up ring	21	Retaining ring	36	Spring
5	Cap	23	Spring	37	Washer
6	Spring	30	Screw	38	Plug
7	Pipe	31	Ball		
14	Return valve	32	Plug		

2) OPERATION

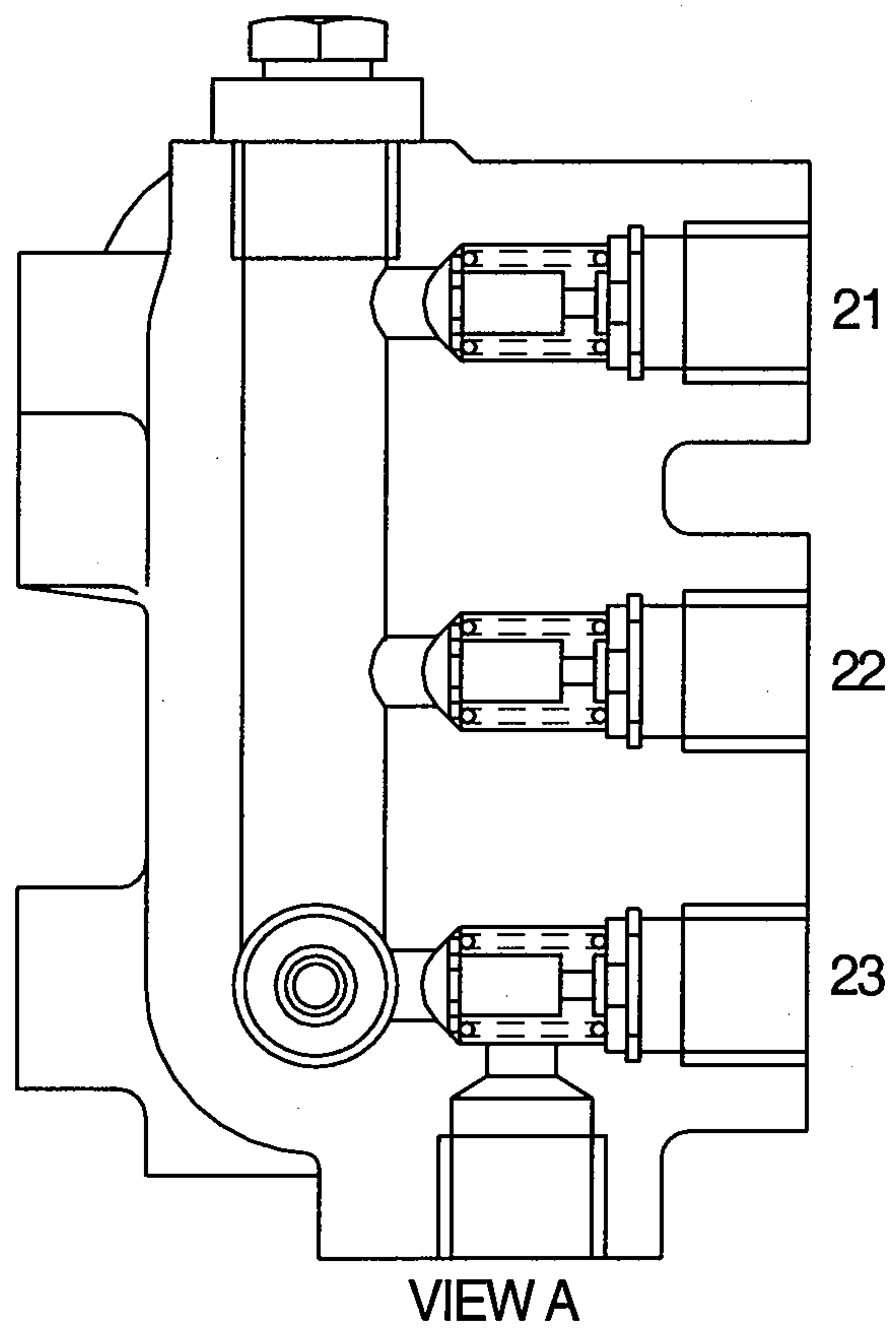
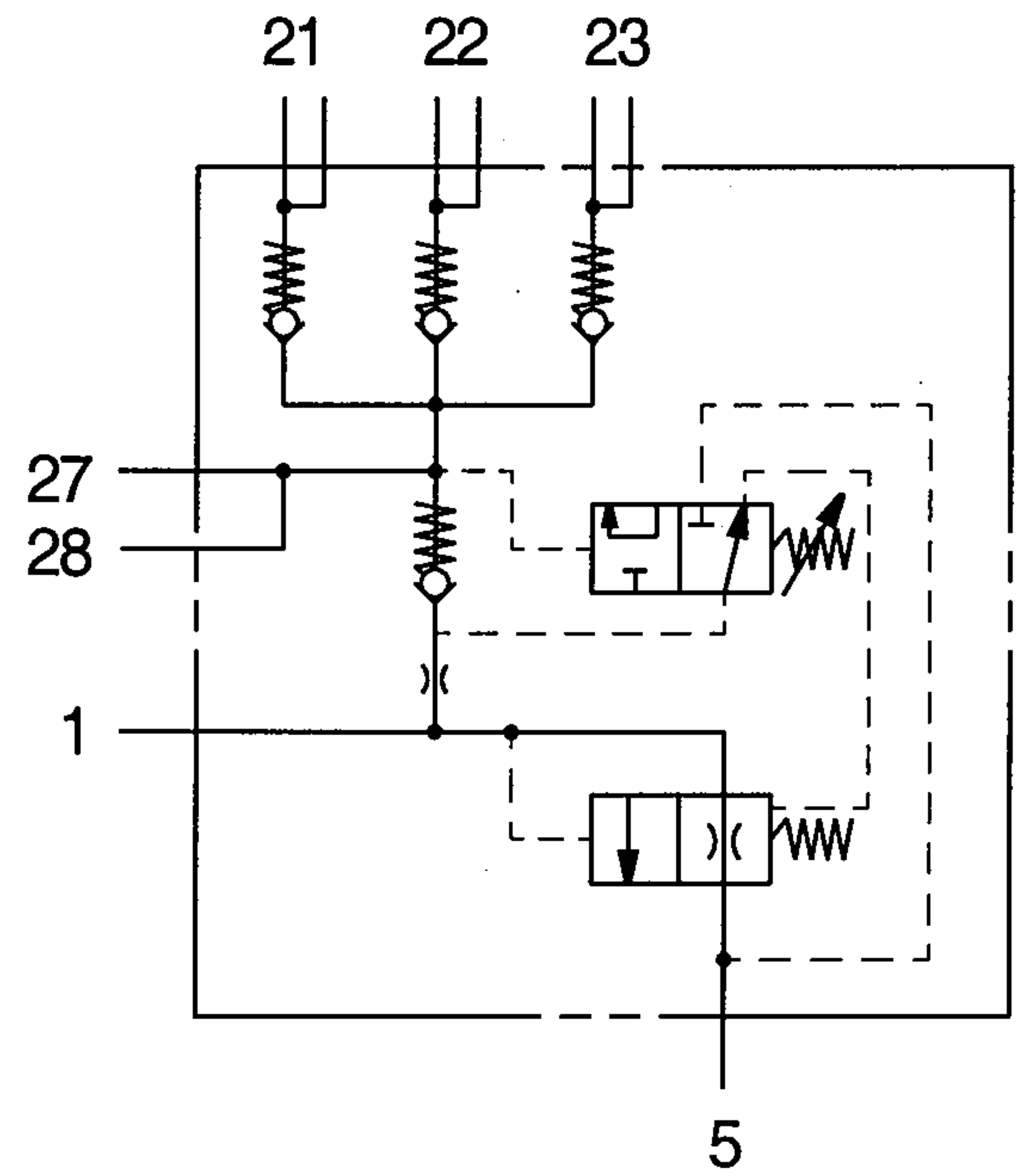
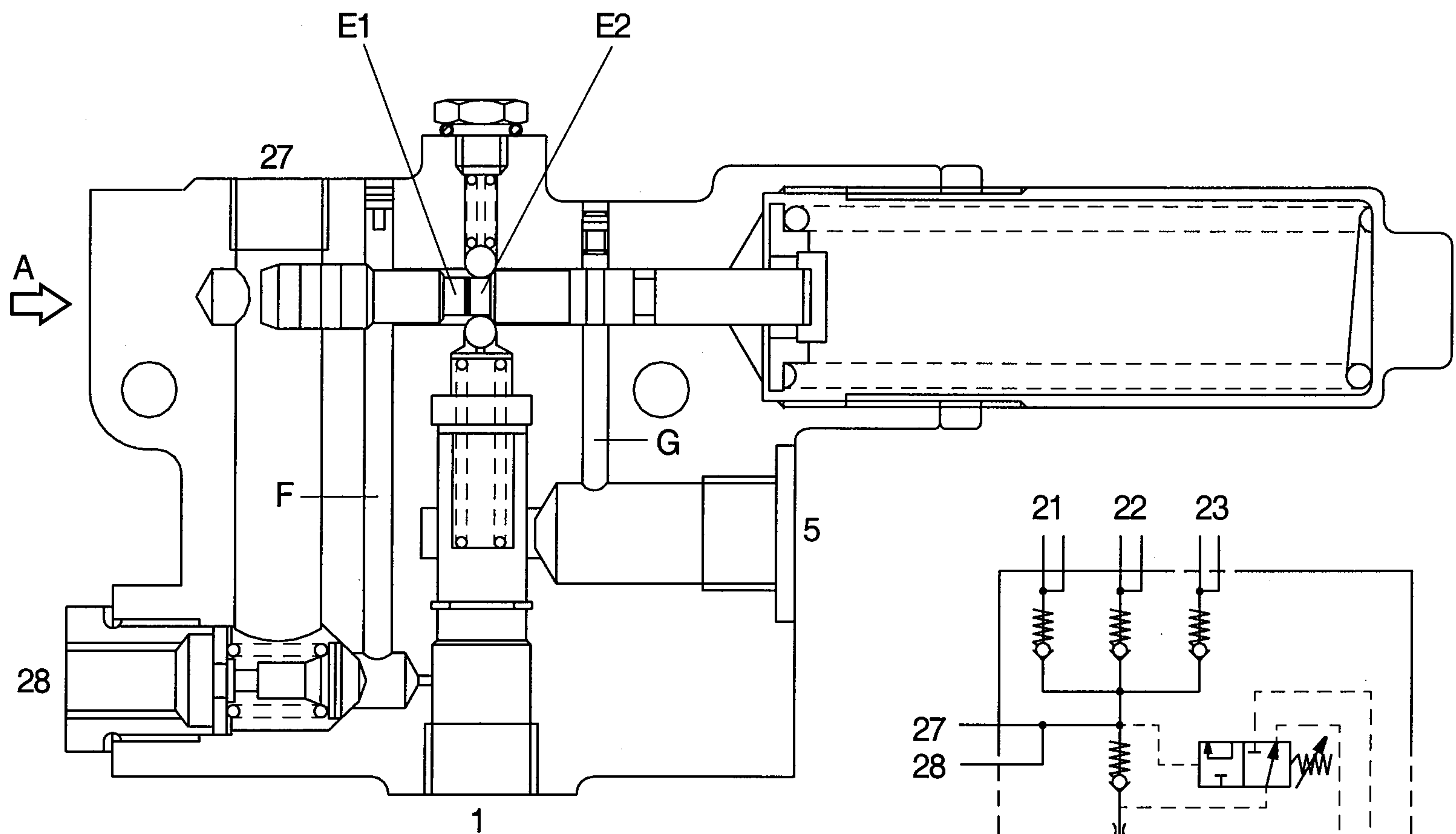

Item	Spec
Cut-in pressure	120+10kgf/cm ²
Cut-off pressure	150-10kgf/cm ²
Flow rate	45 l / min
Flow rate to the brake circuits	3+1 l / min
Max pressure at port 5	Max 200kgf/cm ²
Temperature of medium	-30 ~ +80°C
Ambient temperature	-30 ~ +80°C
Medium	Mineral oil
Torque M12×1.5	2.9±0.31kgf·m
M16×1.5	4.1±0.51kgf·m
M18×1.5	5.1±0.51kgf·m

(1) Purpose

The purpose of the cut-off valve is to control the pressure level in the accumulators.

The cut-off valve must keep the pressure level of the brake accumulators between 120kgf/cm² and 150kgf/cm². This is obtained by a switching mechanism which pressurizes the braking system again to approx. 150kgf/cm², only if the pressure has dropped to less than 120kgf/cm².

(2) Ready position

When the braking system is ready for operation(i.e. the accumulators are charged) the pump stream is present at port 1 of the cut-off valve. A connection is established between ports 1 and 5 so that the pump stream is, with a small difference in pressures, returned directly to the reservoir. The rear of main spool(33) is pressureless. The pressure within the braking system will hold control spool(2) in its locked position(E1) in which the rear of main spool(33) is directly connected to return 5 via hole(G). Check valve(14) in the hole to port 27 secures the accumulator pressure of the operating accumulator. This is available as an additional braking volume for the braking system, preventing excessively frequent actuation of the cut-off valve in the event of a leakage. Shuttle valves(20) additionally secure each braking circuit against pressure losses in the event of a broken pipe.

(3) Charging process

As the accumulator pressure falls to the preset value, control spool(2) will, through the force of spring assembly(6), overcome its locked position(E1) and move to another locked position(E2).

Via orifice(F) and oil stream flows to the rear of main spool(33). The pressure building up at the rear of main spool(33) and the pressure present below main spool(33) put main spool(33) in a floating position, permitting a partial stream to continue to reach port 5 and the remaining stream to flow to ports(21, 22, 23) via check valve(14) until the pressure within the braking system is approx. 150kgf/cm². Control spool(2) will then once again move to locked position(E1) in which a connection is established between ports 1 and 5. The whole of the pump stream once again flows to the reservoir via port 5. Check valve(14) again secures the accumulator pressures.

(4) Installation requirements

The connecting line must be installed in such a way as to permit proper bleeding. The double check valve can be mounted in any position.

(5) Maintenance of the cut-off valve

No special maintenance beyond the legal requirements is necessary.

(6) Repair work

△ **When working on the braking system, always make sure that there is absolutely no pressure in the system. Even when the engine is switched off there will be some residual pressure in the system.**

※ **When doing repair work, make sure your environment is very clean.**

Immediately close all open ports on the components and on pipes using plugs.

※ **For safety reasons the whole of the cut-off valve must be replaced if damaged.**

6. BRAKE ACCUMULATOR

1) STRUCTURE

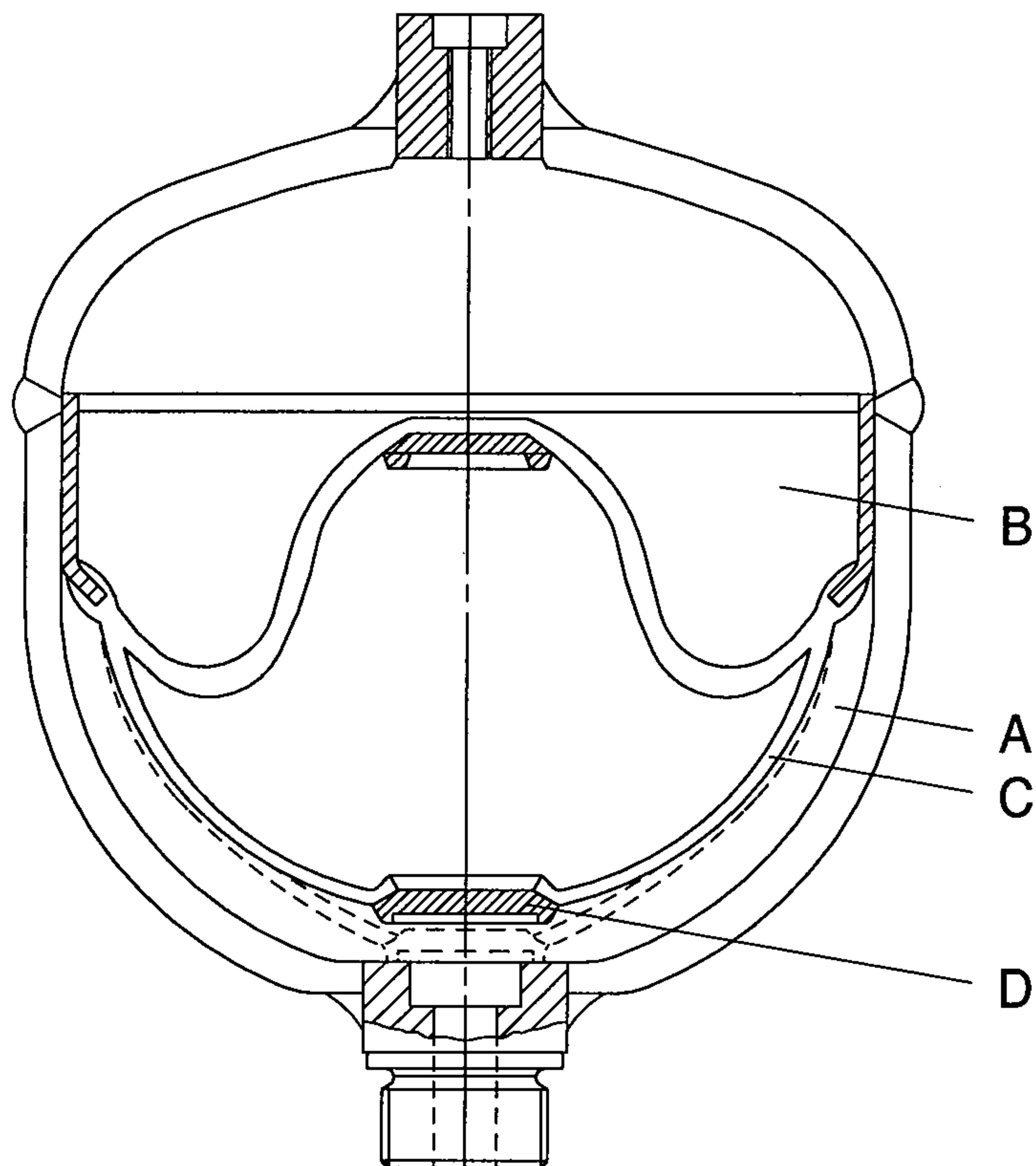

Item	81L1-0003 (Item15)	81L1-0004 (Item16)
Diameter	121mm	136mm
Mounting height	146mm	160mm
Norminal volume	0.75m ³	1.0m ³
Priming pressure	50kgf/cm ²	50kgf/cm ²
Operating medium	Oil	Oil
Operating pressure	Max 180kgf/cm ²	Max 200kgf/cm ²
Thread	M18×1.5	M18×1.5
Operating temperature range	-30 ~ 80°C	-30 ~ 80°C
Priming gas	Nitrogen	Nitrogen

A Fluid portion

B Gas portion

C Diaphragm

D Valve disk

2) OPERATION

(1) Purpose

Fluids are practically incompressible and are thus incapable of accumulating pressure energy. In hydropneumatic accumulators, the compressibility of a gas is utilized to accumulate fluid. The compressible medium used in the accumulators is nitrogen.

In braking systems, the purpose of the accumulators is to store the energy supplied by the hydraulic pump. They are also used as an energy reserve when the pump is not working, as a compensator for any losses through leakage, and as oscillation dampers.

(2) Operation

The accumulator consists of a fluid portion (A) and a gas portion (B) with a diaphragm (C) as a gas-tight dividing element. The fluid portion (A) is connected to the hydraulic circuit, causing the diaphragm accumulator to be filled and the gas volume to be compressed as the pressure rises.

When the pressure falls, the compressed gas volume will expand, thus displacing the accumulated pressure fluid into the circuit.

The diaphragm bottom contains a valve disk (D) which, if the diaphragm accumulator is completely empty, closes the hydraulic outlet, thus preventing damage to the diaphragm.

(3) Installation requirements

The accumulators can be fitted in the hydraulic circuit, directly on a component or in blocks on suitable consoles.

They should be fitted in as cool a location as possible.

Installation can be in any position.

(4) Maintenance of the accumulator

No special maintenance beyond the legal requirements is necessary.

The accumulator should be checked annually. It should be replaced if the initial gas pressure has fallen by more than 30%(Please refer to **Performance testing and checking of the accumulator**).

(5) Disposal of the accumulator

Before the accumulator is scrapped, its gas filling pressure must be reduced. For this purpose, drill a hole through gas chamber(B) using a drill approx. 3mm in diameter. The gas chamber is located on the side opposite the threaded port above the welding seam around the center of the accumulator.

※ **Wear safety goggles when doing this job.**

(6) Performance testing and checking of the accumulator

The accumulator is gradually pressurized via the test pump; until the initial gas pressure is reached, the hydraulic pressure in the accumulator will rise abruptly. This is apparent from gauge **M**. If the initial gas pressure is more than 30% below the prescribed value, the accumulator needs to be replaced. If the measuring process needs to be repeated, wait for intervals of 3 minutes between the individual tests. Any accumulator whose initial gas pressure is insufficient must be scrapped following the instructions under **Disposal of the accumulator**.

The amount of initial gas pressure can also be checked from the vehicle. Start the vehicle's engine. The pump will now supply oil to the accumulators. Until the initial gas pressure is reached, the hydraulic pressure in the accumulator will rise abruptly. This is apparent from the gauge in the cab. If the initial gas pressure is more than 30% below the prescribed value, that initial pressure lies outside the permissible range for **at least one** of the accumulators fitted in the vehicle. This accumulator can be traced only by using the method described above, i.e. all accumulators have to be individually tested. The accumulator whose initial gas pressure is insufficient must be replaced and scrapped following the instruction under **Disposal of the accumulator**.

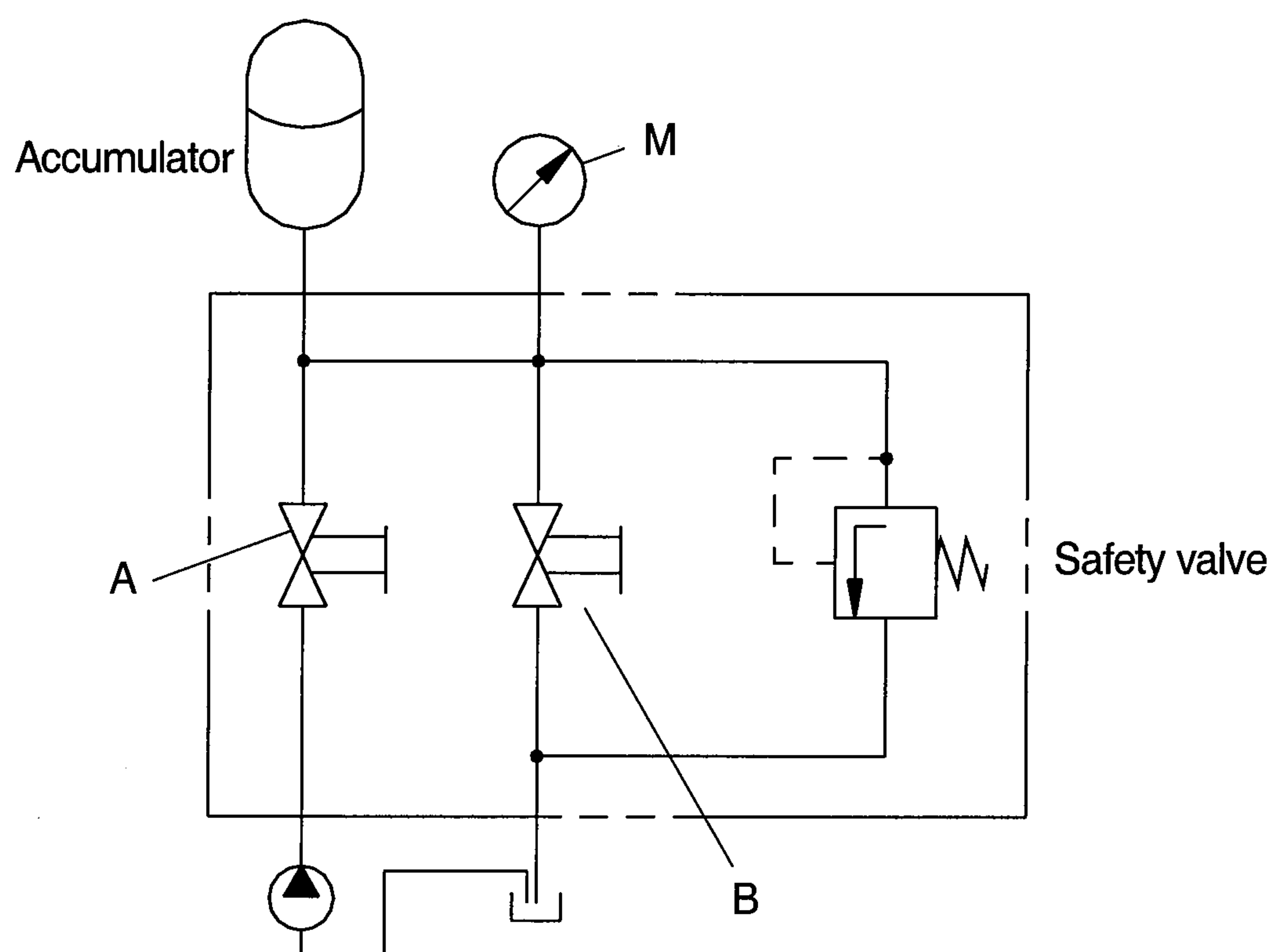

(7) Repair work

- △ When working on the braking system, always make sure that there is absolutely no pressure in the system. Even when the engine is switched off there will be some residual pressure in the system.**
- ※ When doing repair work, make sure your environment is very clean. Immediately close all open ports on the components and on pipes using plugs.**
- △ For safety reasons the accumulators need to be replaced as a whole if damaged.**

7. PRESSURE SWITCHES

1) STRUCTURE

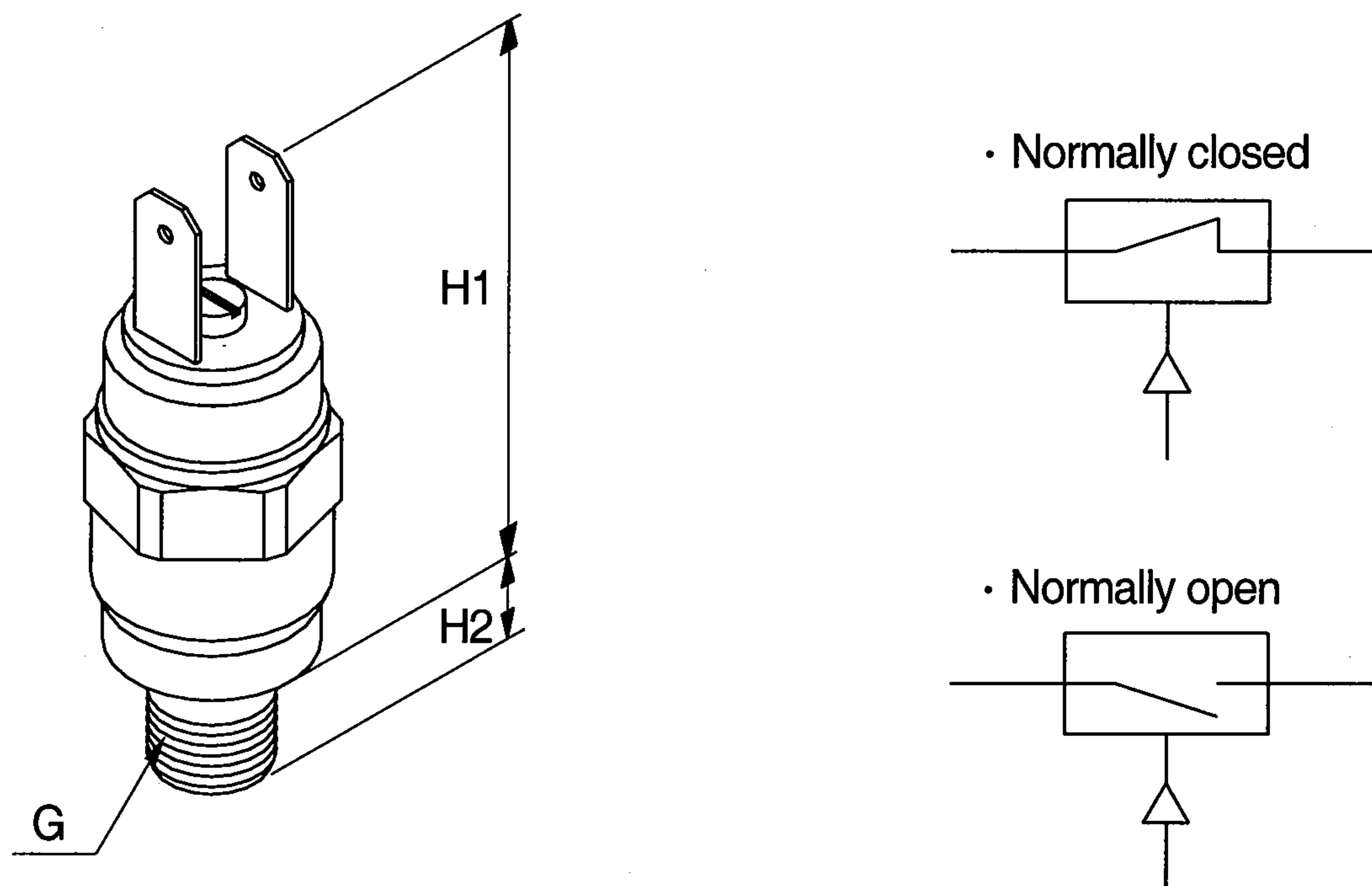

• Technical data

Item	Type	Medium	G	H1 mm	H2 mm	Adjusting range kgf/cm ²	Adjusting pressure kgf/cm ²	Voltage V
Parking	NC	Oil	M12×1.5	55	9	20 ~ 50	21 ± 2	Max 42
Charging	NC	Oil	M12×1.5	55	9	50 ~ 150	100 ± 10	Max 42
Brake stop	NO	Oil	M12×1	43	9	3 ~ 6	3 ~ 6	Max 42
Clutch cut-off	NO	Oil	PF 1/4"	55	9	20 ~ 50	24 ± 2	Max 42

NC : Normally closed

NO : Normally open

2) OPERATION

(1) Purpose

The pressure switches are used to visually or audibly warn the driver of the pressure within the system.

(2) Make contact / circuit closer

The pressure switch can be fitted in the braking system or directly on one of its components.

The system pressure acts on an absorption area within the switch, making an electrical contact as the pressure on that area is increased. The resulting current is used to activate a warning facility, for instance.

(3) Break contact / circuit breaker

The pressure switch can be fitted in the braking system or directly on one of its components.

The system pressure acts on a absorption area within the switch, breaking an electrical contact as the pressure on that area is increased. The current is now broken, e.g. to deactivate a warning facility.

(4) Installation requirements

No special measures need to be taken.

(5) Maintenance of the pressure switch

No special maintenance beyond the legal requirements is necessary.

When using high-pressure cleaners on the vehicle, please make sure that the water jet is not directed at the pressure switch(Corrosion of contacts).

(6) Repair work

△ **When working on the braking system, always make sure that there is absolutely no pressure in the system. Even when the engine is switched off there will be some residual pressure in the system.**

※ **When doing repair work, make sure your environment is very clean.**

Immediately close all open ports on the components and on pipes using plugs.

※ **For safety reasons the pressure switch needs to be replaced as a whole if damaged.**

(7) Adjusting and testing pressure switch

The adjusting screw located between the two contact plugs can be set to the desired value within a certain range. For adjusting range, please refer to the table **Technical data** on the previous page.

After making the adjustment, the adjusting screw should be secured using wax or a similar material.

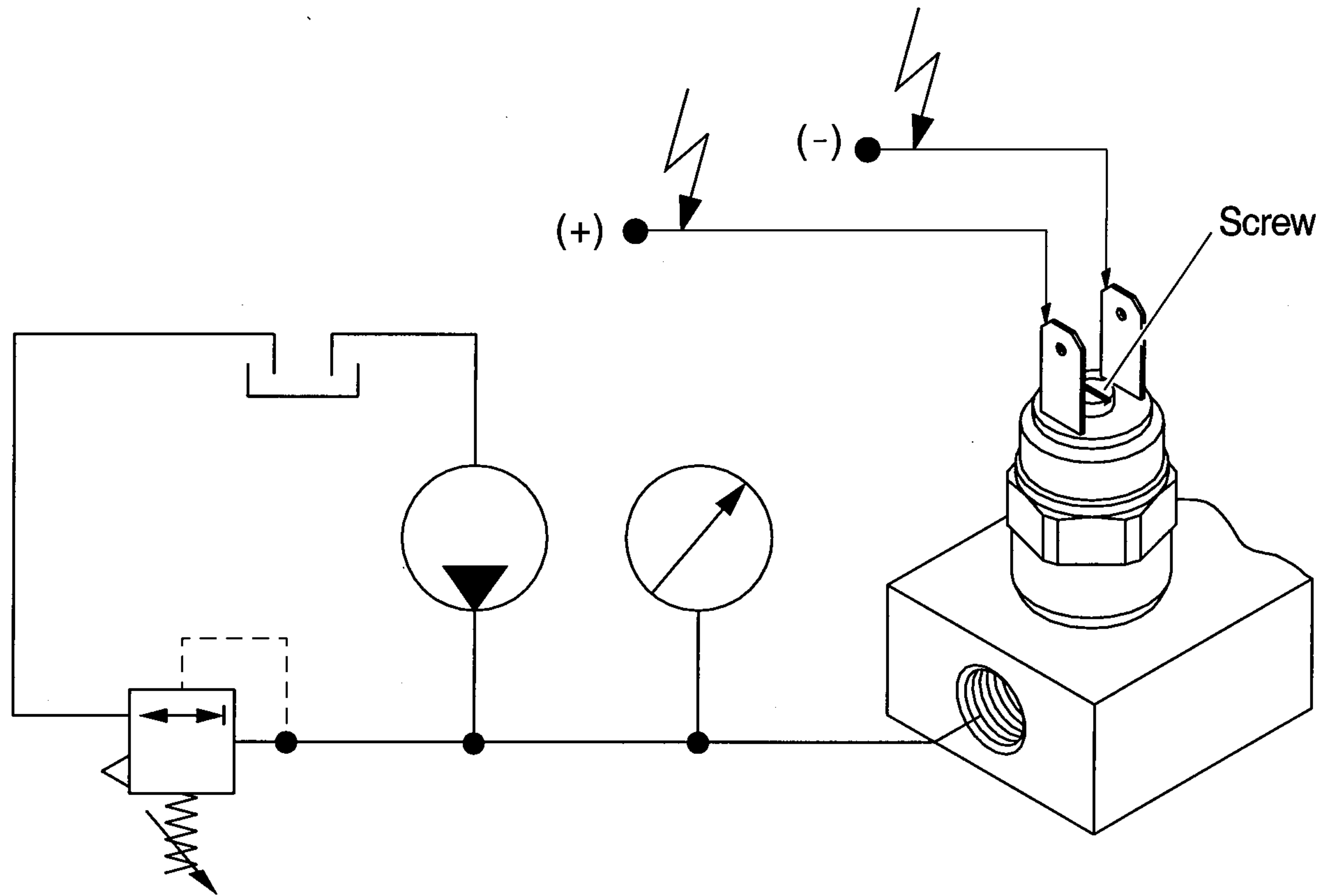

8. PARKING BRAKE

1) STRUCTURE

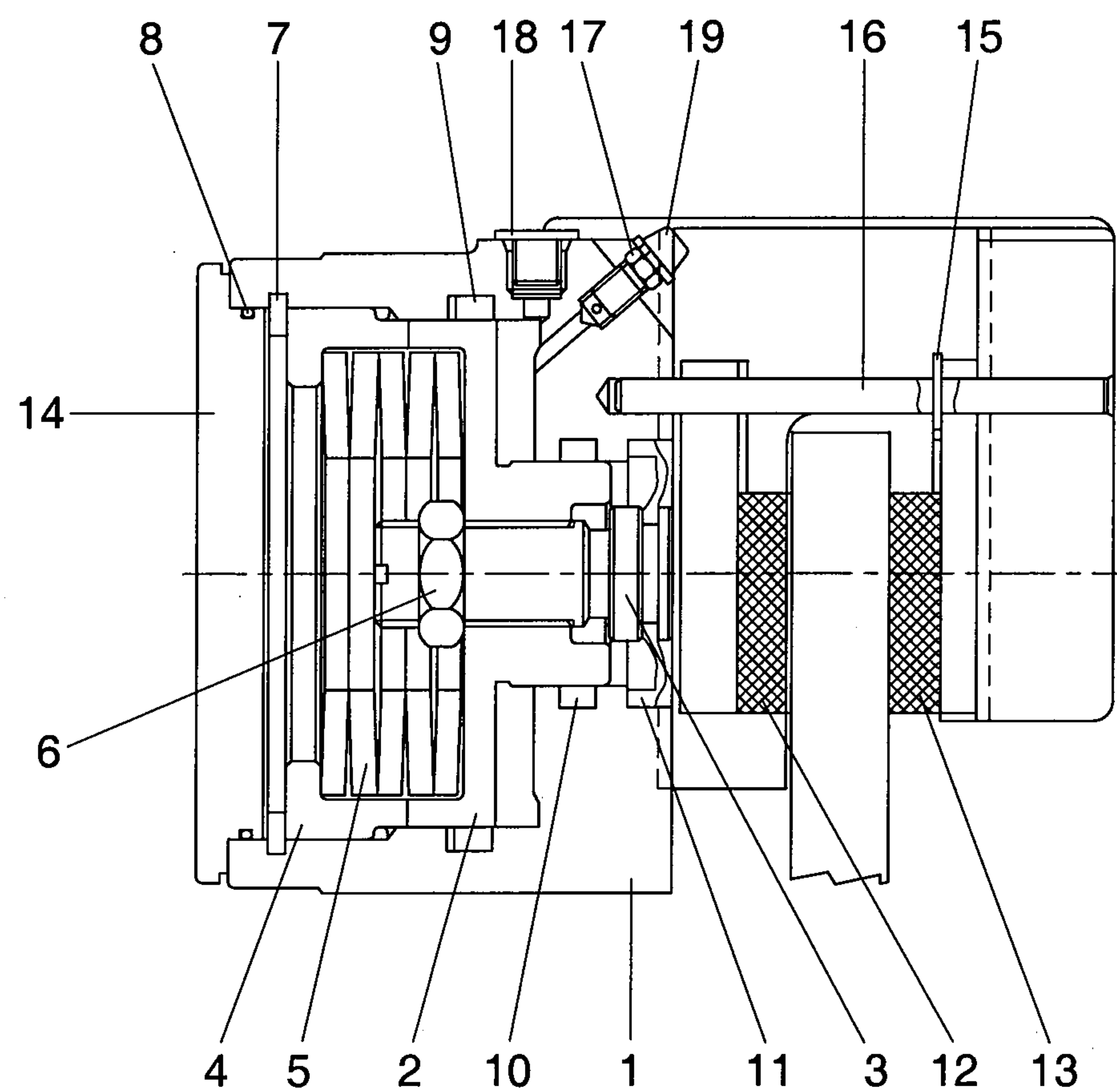

- | | | | | | |
|---|-------------------|----|--------------------|----|-----------------------|
| 1 | Caliper mainframe | 8 | Rubber chocke ring | 15 | Pin |
| 2 | Thrust piston | 9 | Chocke ring | 16 | Supporting pads pivot |
| 3 | Cylinder | 10 | Chocke ring | 17 | Bleed valve |
| 4 | Base | 11 | Dust protector | 18 | Plug |
| 5 | Loaded springs | 12 | Inner brake pad | 19 | Plug |
| 6 | Blocking nut | 13 | Outside brake pad | | |
| 7 | Locking | 14 | Aluminium cap | | |

2) SETTING OF THE CALIPER

(1) Brake pads fitting up

- ※ Brake pads are not interchangeable as they have a different thickness. The inside brake pad is thicker(25mm) and must be put on the thrust piston side.
- ① Insert the brake pads into the upper part of the caliper by sliding them downwards into their own seats. The side of the brake pad having an elliptic hole must stay toward the top.
- ② Insert the support pivot(16) into its seat on the caliper by using the 15mm hole on the plate and then make it pass into the pads elliptic holes. On the pivot(16) there is a hole made to allow the pin's passage(15). Pivot must be inserted on the part where distance between pin's hole/pivot's edge is larger.
- ③ Put the pin against the plate up to the hole made for the pin exceeds the disc pad backing plate. Pin must be then inserted and opened in order to avoid it can get unthreaded.

(2) Hydraulic connections

- ① Check thread's cleanliness.
- ② Connect the hydraulic oil pipe by inserting the copper washer.
- ③ Load the circuit and make the bleeding by acting on the valve(17).
- ④ Clasp the valve(17) without exceeding 0.6kgf · m(4.4lbf · ft).
- ※ A too much high locking couple should jeopardize the seat's valve or cause the valve's breakage.

(3) Brake pads adjustment

- ※ Make sure that caliper can slide without any problem on the pivots(16). Then raise pressure the circuit by checking that piston is drawn back. Springs are now compressed and brake pads can be adjusted to the following instructions.
- ① Turn the screw(3) clockwise by using a screwdriver. At the same time caliper must be moved ahead by sliding in on pivots in order to let brake pads to bed against the disc brake surface.
- ② Turn the screw(3) counter clock-wise just for a turn which means 1.5mm.
- ③ Keep the screw(3) steady and clasp the nut(6) by using a 35mm key.

(4) Brake caliper fastening

Insert aluminium cap(14) by paying much attention in order to avoid to spoil the weather strip.
Screw tight the screws(21).

4) BRAKE CALIPER'S SERVICING

Considering that the caliper can't never be used as a service brake but just as emergency brake a regular servicing must be done every 500 working hours. Should the caliper be used in very heavy conditions or always in contact with both water and mud, the above mentioned interval(500 working hours) must be reduced.

- ※ Caliper must be used as safety and emergency device. For this reason when a servicing operation must be done on a machine equipped with such device make sure that the machine is stopped in some other way.

(1) Clearances adjustment

- ※ Brake pads clearance must checked when brake circuit is on pressure.
- ① Draw the caliper back in order to bring the outside brake pad against the brake disc and adjust clearances due to the wear on the surface of the inside brake pad(Toward the piston).
- ② Unscrew the nut(6).
- ③ Through a screwdriver turn the screw(3) clockwise until the rear brake pad in against the brake disc.
- ④ Turn the screw(3) clockwise just for a turn which means 1.5mm.
- ⑤ Keep the screw(3) steady and clasp the nut(6) by using a 35mm key.

(2) Pad replacement procedures

When the lining of each brake pad has worn respectively to 15 and 20mm(The inner brake pad is thicker) the pads must be replaced.

A replacement every 5 years is highly recommended since after a long period the lining performances can drop.

After raising the brake circuit in pressure, follow the below mentioned instructions

- ① Unscrew the screws(21) and remove the cap(14) by levering up through a screwdriver.
- ② Loosen the nut(6) by using a 35mm key.
- ③ Unscrew the adjuster(3) as far as a clearance of 3~4mm between pads and brake disc is made.

When brake circuit is without pressure

▲ Before releasing hydraulic pressure in the circuit make sure there is no one working nearby the caliper, because without pressure, springs start working closing immediately the pads against the disc surface. It's very dangerous for your own fingers.

- ① Pull out the safety device(15).
 - ② Unthread the pivot(16) on the brake pads.
 - ③ Pull out brake pads from their seat by moving them toward the top.
 - ④ For brake pads fitting please refer to section (1) at page 4-27.
- ※ Brake pads are not interchangeable as they have a different thickness. The inside brake pad is thicker(25mm) and must be put on the thrust piston side.