

# GROUP 4 DISASSEMBLY AND ASSEMBLY

## 1. FLOW AMPLIFIER

### 1) STRUCTURE

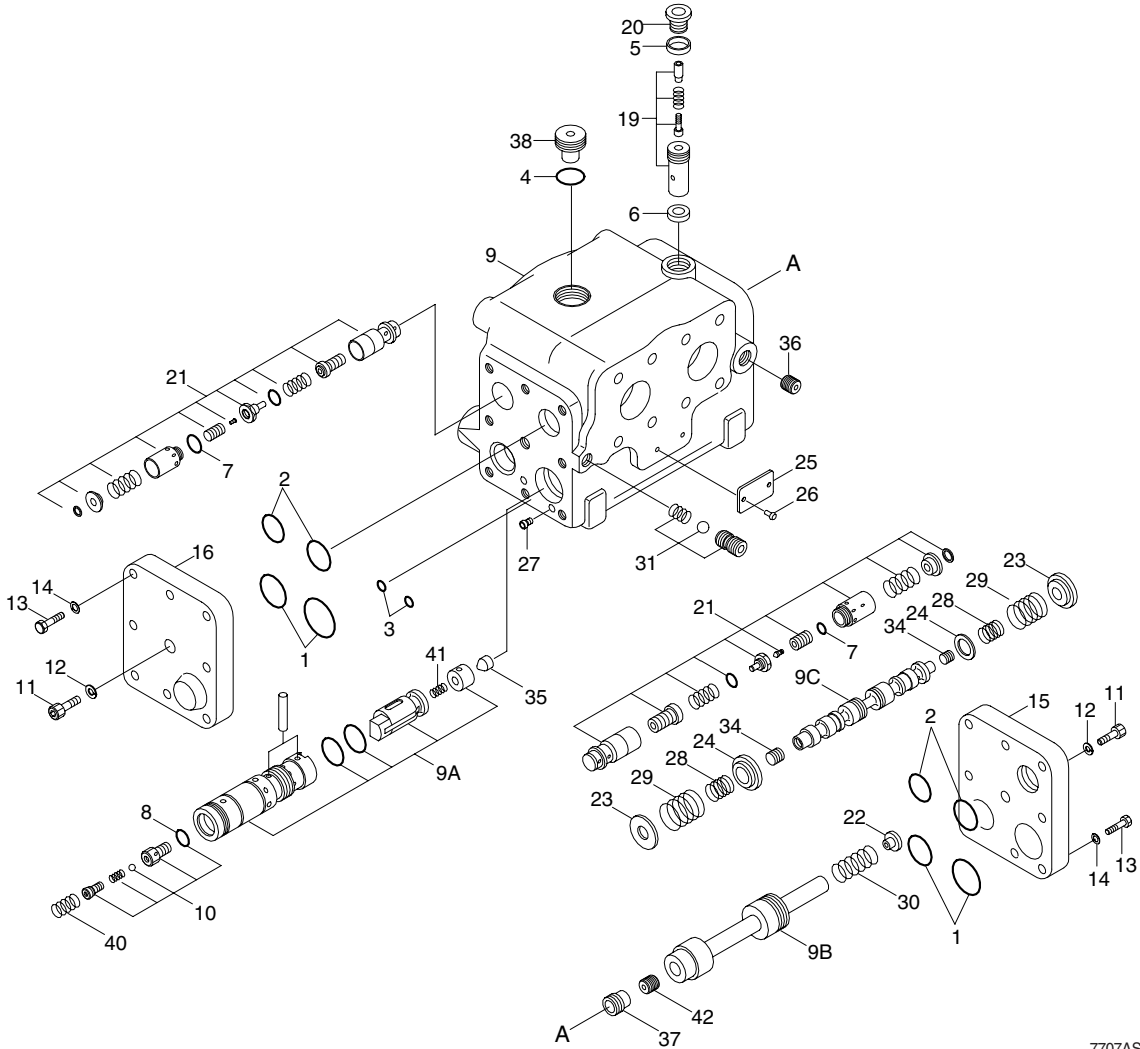

7707ASE09

1	O-ring	12	Spring washer	28	Spring
2	O-ring	13	Screw	29	Spring
3	O-ring	14	Spring washer	30	Spring
4	O-ring	15	End cover	31	Throttle check valve
5	Washer	16	End cover	34	Orifice
6	Washer	19	Relief valve	35	Orifice
7	O-ring	20	Plug	36	Orifice
8	O-ring	21	Shock, suction valve	37	Plug
9	Housing	22	Spring seat	38	Plug
9A	Amplifier valve	23	Spring seat	40	Spring
9B	Priority valve	24	Spring guide	41	Spring
9C	Directional valve	26	Name plate	42	Orifice
10	Check valve	27	Orifice		
11	Screw				

## 2) TOOLS

- Guide screws : M8 × 1.0
- Hook : Wire

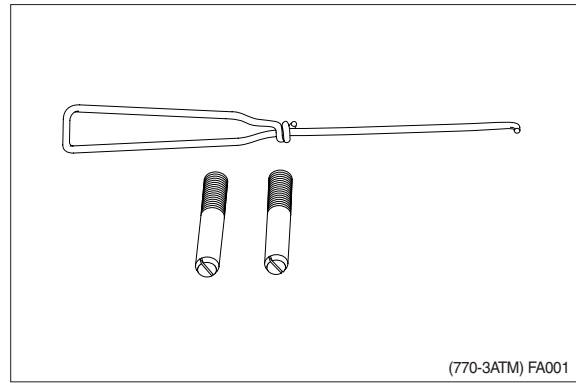

- Hexagon keys : 4, 5, 6, 8 and 10 mm
- Ratchet for socket spanners
- Hex socket for external : 13, 17 & 19 mm
- Hex socket for internal : 8 & 10 mm
- Multigrip pliers
- Ring spanner: 13 mm
- Screwdrivers : 3 and 10 mm
- Steel Mandrels : 3, 5 and 8 mm
- Torque wrench : 12.2 kgf · m (88 lbf · ft)
- Magnetic rod

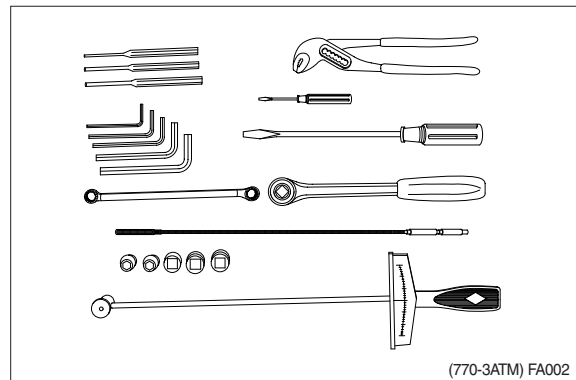

## 3) DISASSEMBLY

### (1) Disassembly counter pressure valve

- ① Unscrew plug with O-ring (hexagon socket for 8 mm internal hexagon).

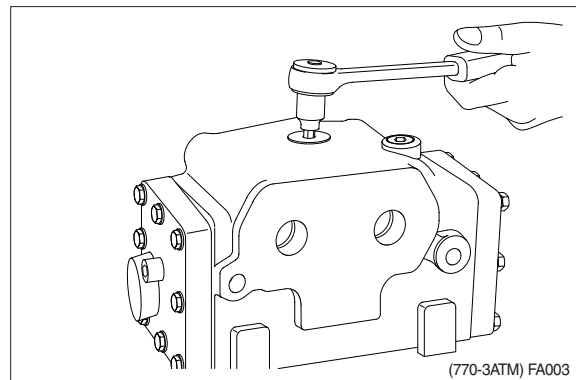

- ② Take out small spring (hook).

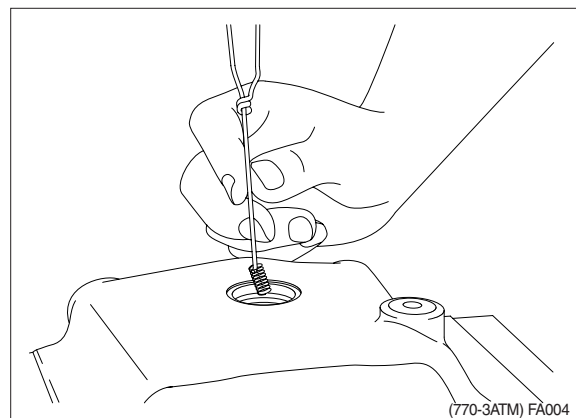

③ Take out ball (magnetic rod).

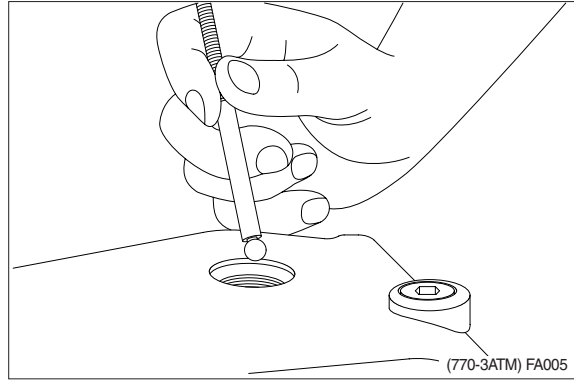

④ Take out piston.

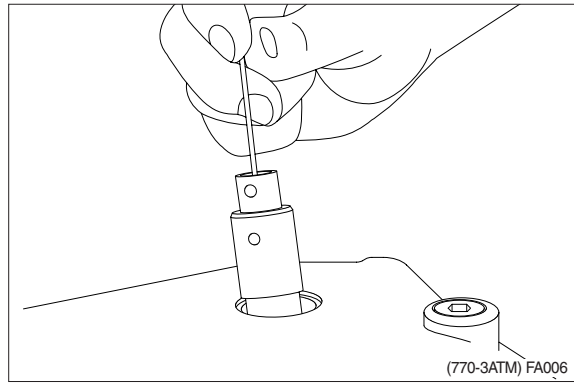

⑤ Take out spring.

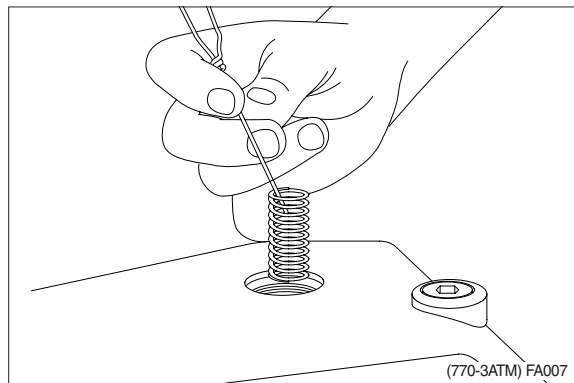

⑥ Counter pressure valve shown disassembled.

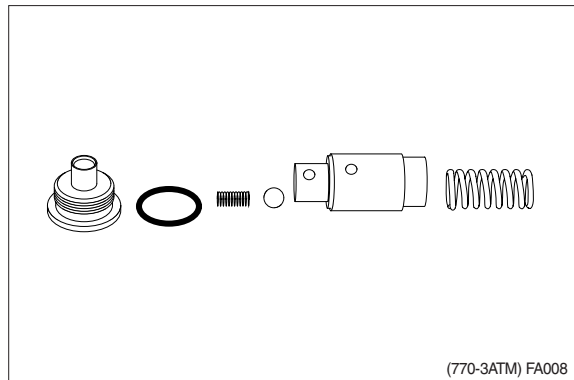

- ⑦ Counter pressure valve with orifice shown disassembled.

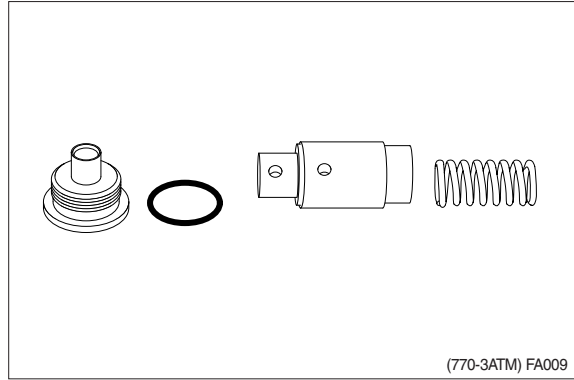

**(2) Removing pressure relief valve**

- ① Unscrew plug with washer (hexagon socket for 8 mm internal hexagon).

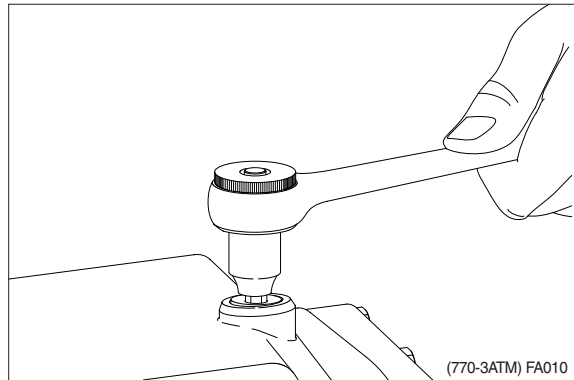

- ② Screw pressure relief valve out (10 mm hexagon key).

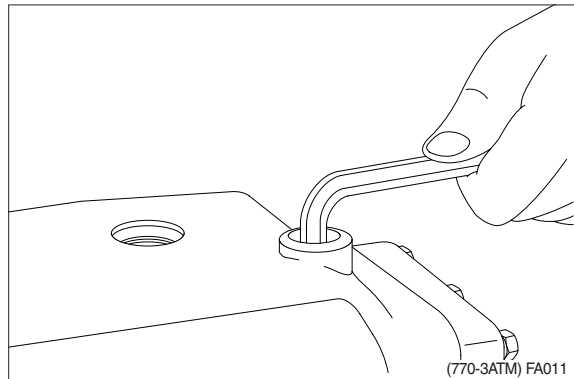

- ③ Take out washer (Magnetic rod).

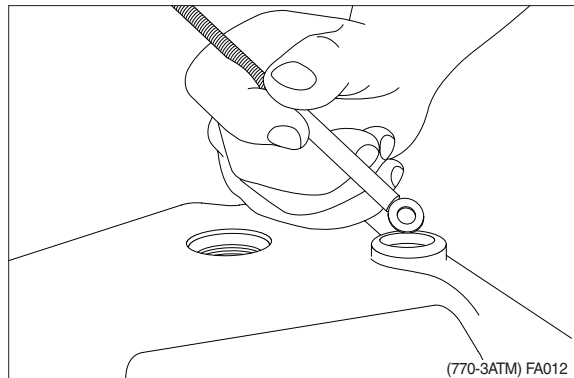

### (3) Disassembly pressure relief valve

- ① Hold cartridge (multigrip pliers) and screw the adjustment screw out (5 mm hexagon key).

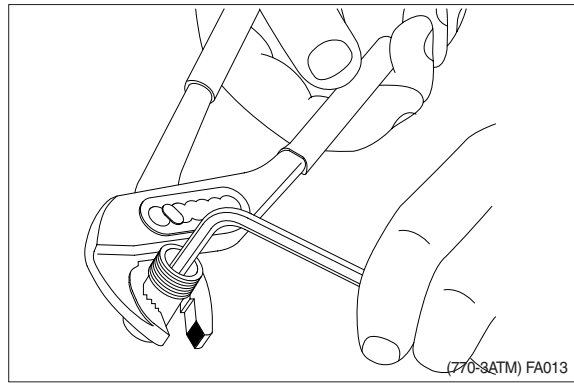

- ② Pressure relief valve shown disassembled.

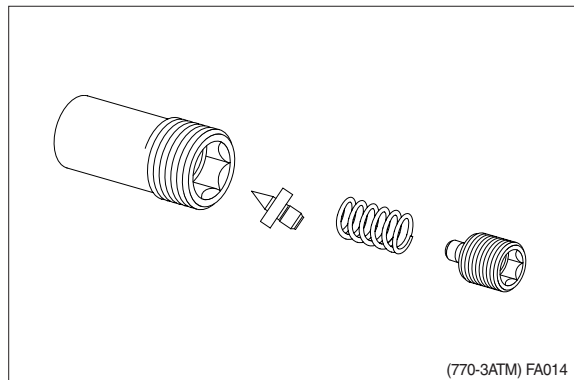

### (4) Removing end cover at PP-connection

- ① Unscrew screws with spring washer using hexagon socket for 13 mm external hexagon and 10 mm internal hexagon.

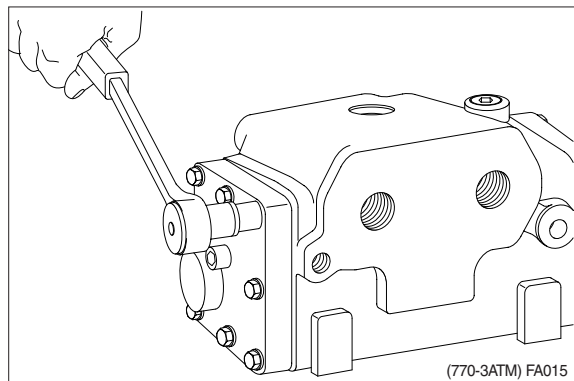

- ② Remove end cover.

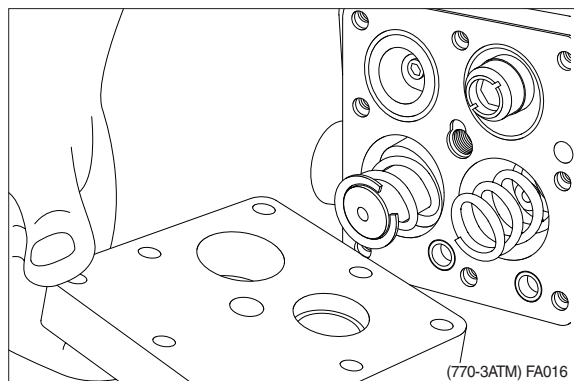

③ Remove stop and 2 springs.

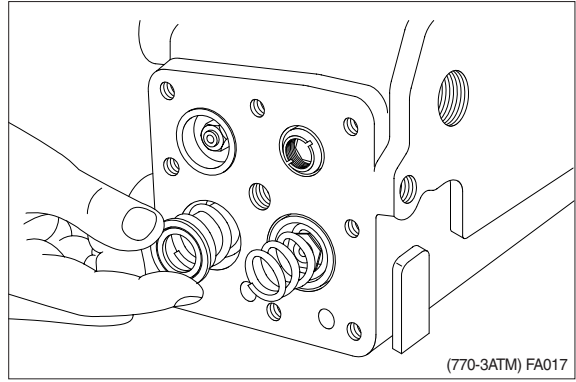

④ Remove spring.

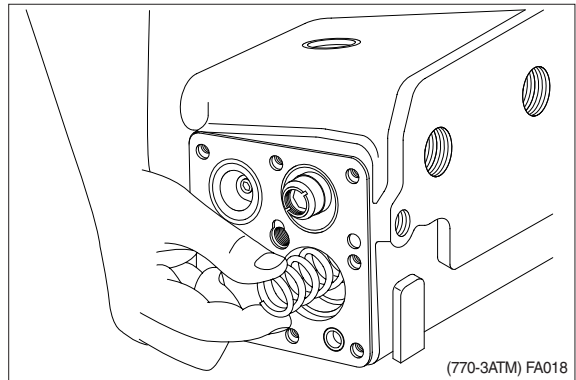

③ Remove plate and 6 O-rings.

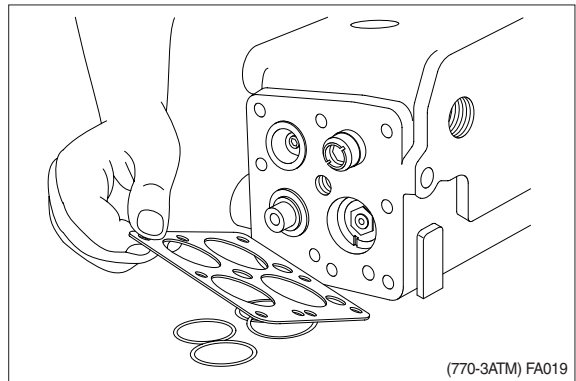

④ Remove spring guide.

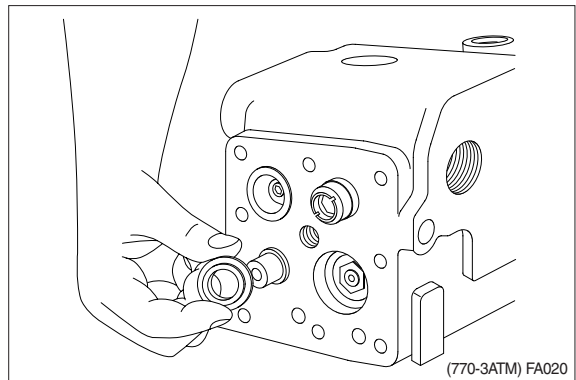

### (5) Removing end cover at LS-connection

- ① Unscrew screws with spring washer using hexagon socket for 13 mm external hexagon and 10 mm internal hexagon.

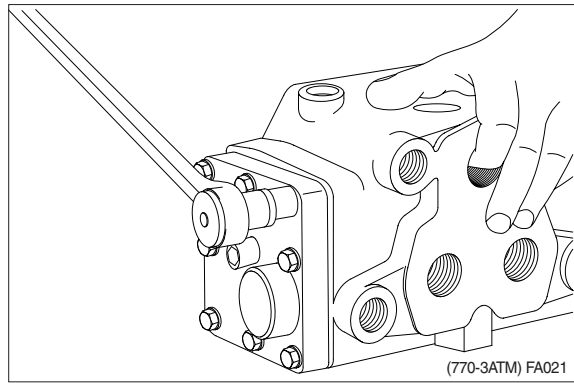

- ② Remove end cover.

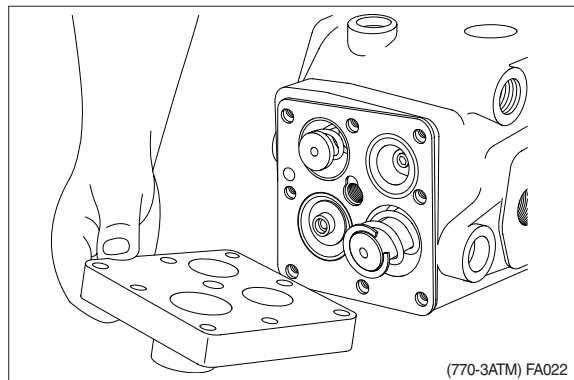

- ③ Remove stop and 2 springs.

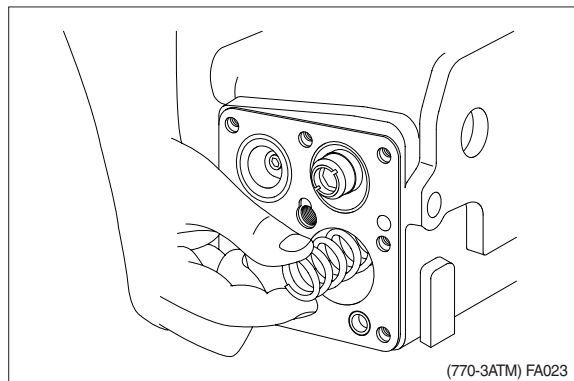

- ④ Remove stop and spring.

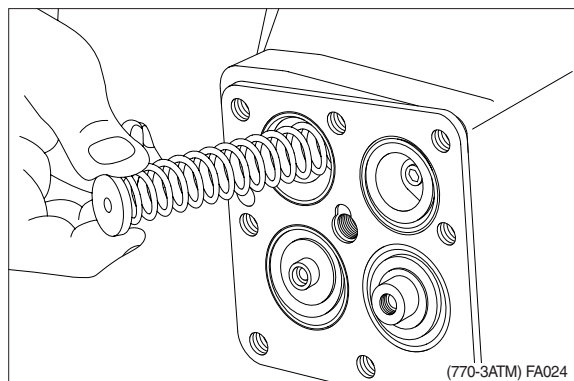

⑤ Remove plate and 4 O-rings.

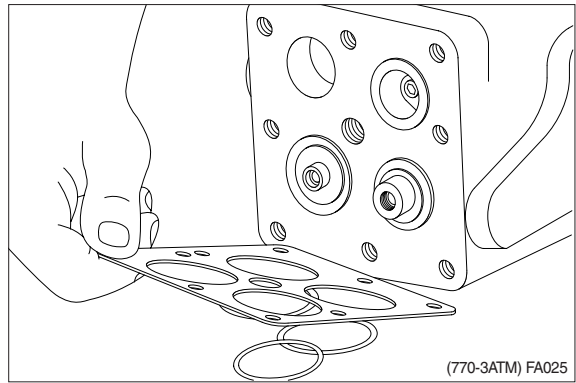

⑥ Remove spring guide.

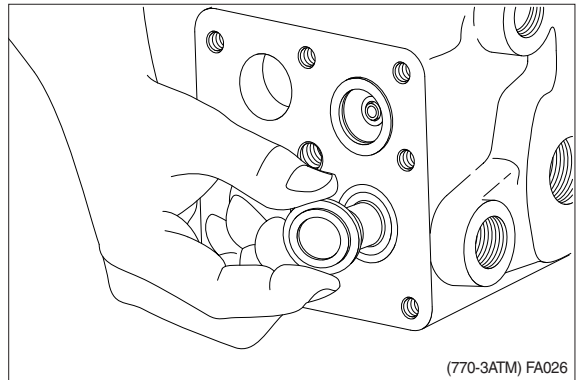

## (6) Removing spools

① Remove directional spool.

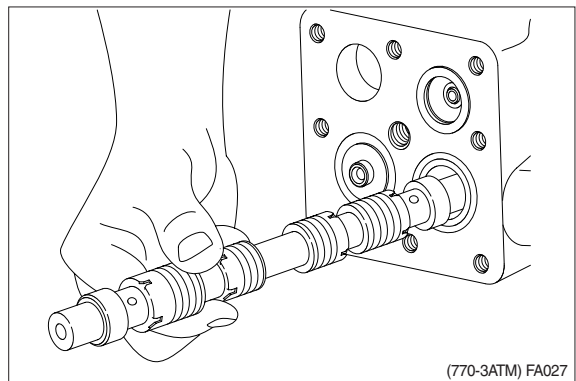

② Remove amplifier spool.

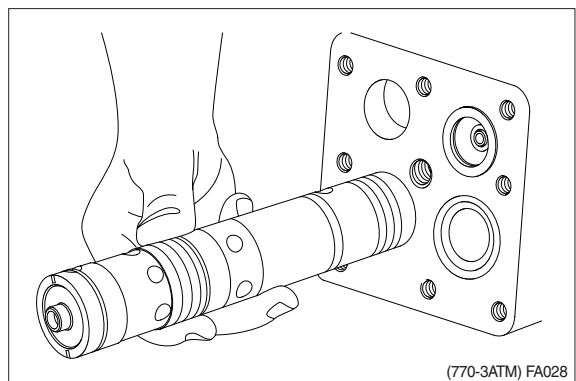

- ③ Remove priority valve spool.

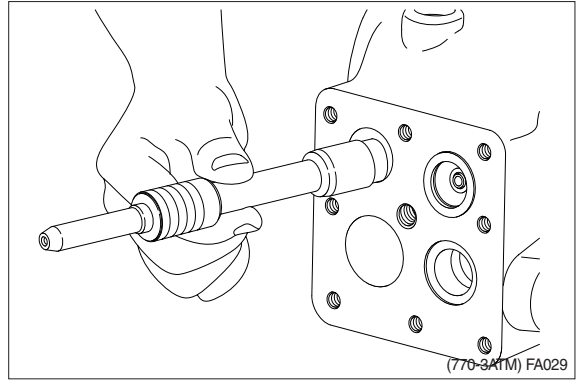

**(7) Removing orifices and throttle check valve**

- ① Unscrew orifice in LS-connection with 6 mm hexagon key.

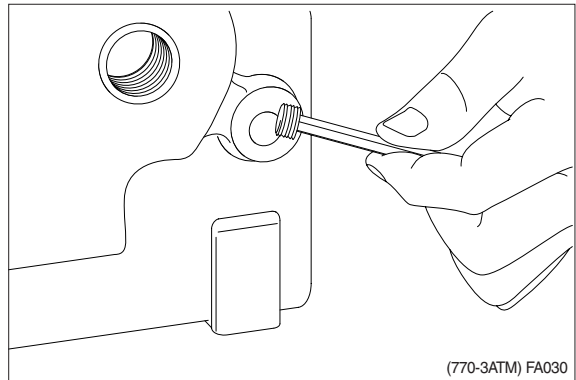

- ② Unscrew throttle check valve in PP-connection with 6mm hexagon key.

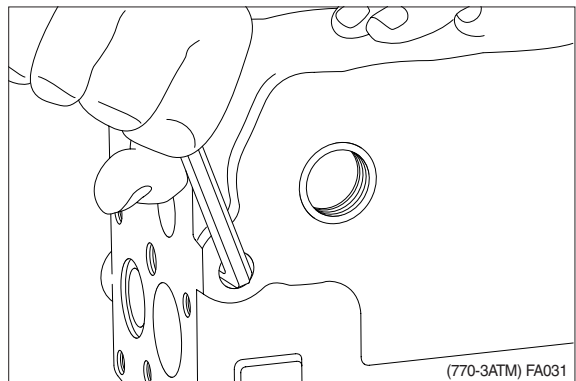

- ③ Unscrew orifice in housing with 4 mm hexagon key.

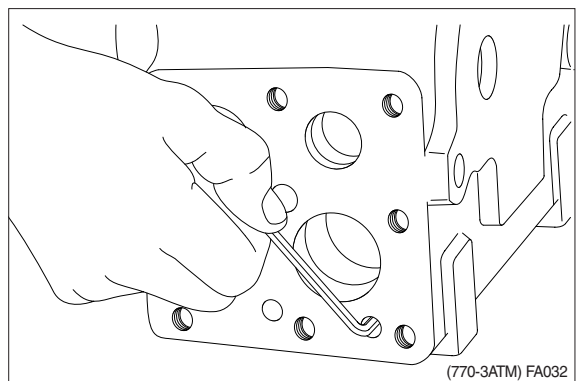

### (8) Removing shock valves

- ① Remove shock valve with screwdriver and hexagon key.

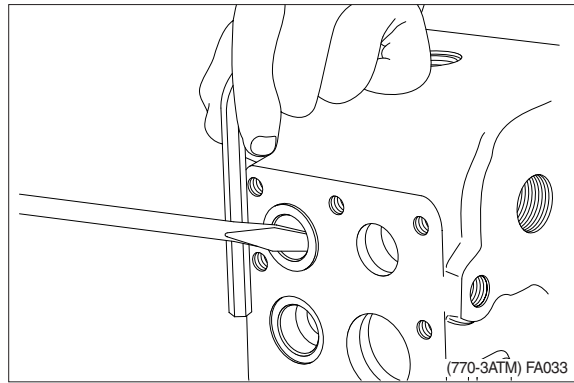

### (9) Overview of disassembled parts

- ① Housing and end cover with accessories.

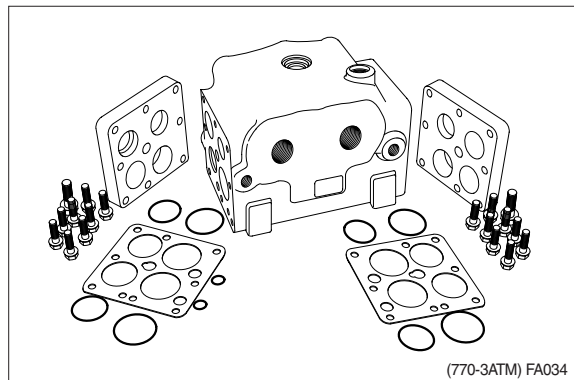

- ② Spool with accessories.

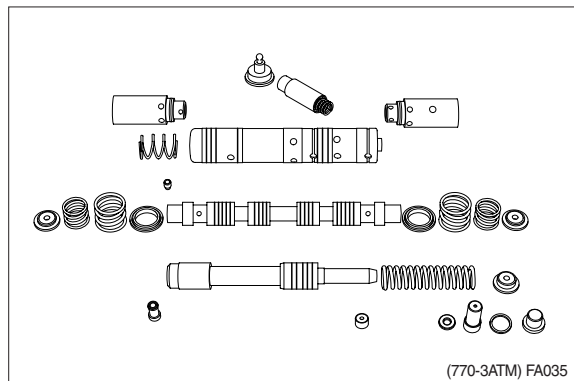

### (10) Disassembly of directional spool

- ① Unscrew orifice with 4 mm hexagon key. Use a mandrel.

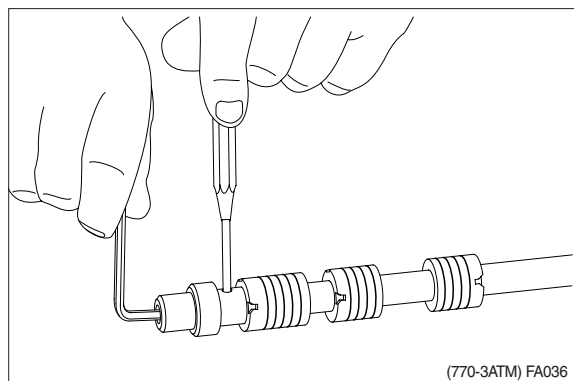

② Directional spool shown disassembled.

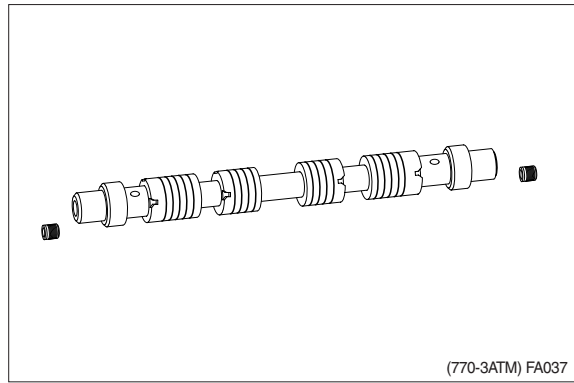

### (11) Disassembly of priority valve spool

① Unscrew plug or throttle check valve with 8 mm hexagon key.

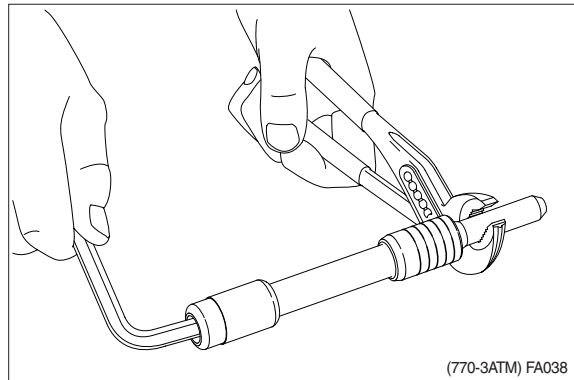

② Priority valve spool with plug for external PP shown disassembled.

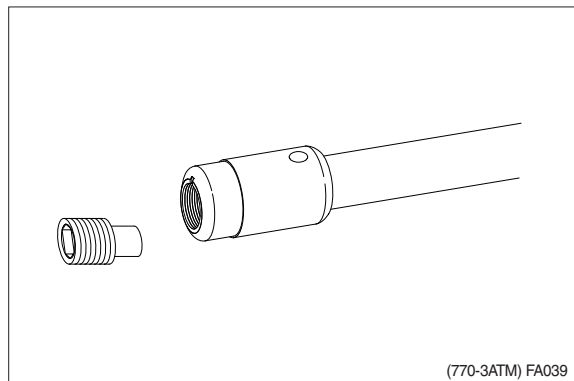

③ Priority valve spool with throttle check valve for internal PP shown disassembled.

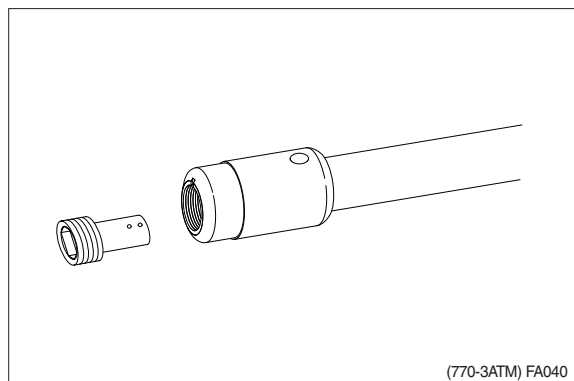

## (12) Disassembly of amplifier spool

- ① Carefully remove the spring ring from the recess with 3mm screwdriver.
- ※ Avoid damage to the spring ring.

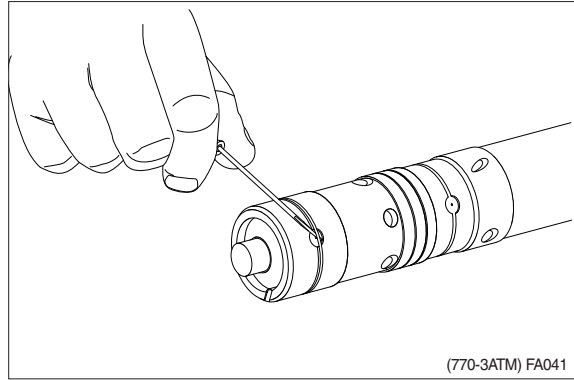

- ② Carefully guide the spring ring back.

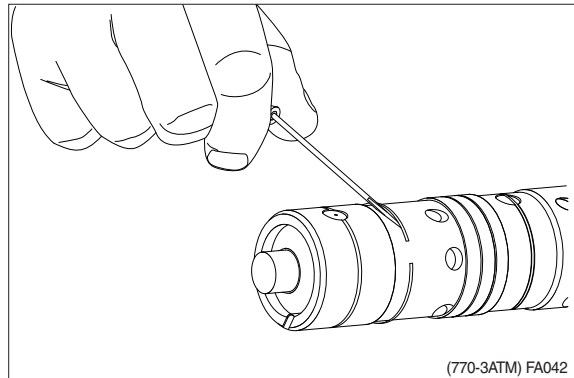

- ③ Carefully take the spring ring from the recess and guide it back with 3mm screwdriver.
- ※ Avoid damage to the spring ring.

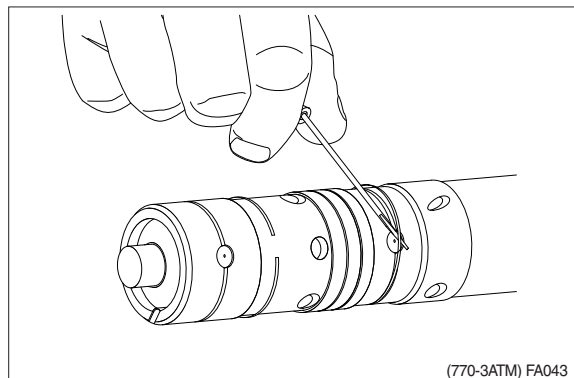

- ④ Press pin out gently with finger.

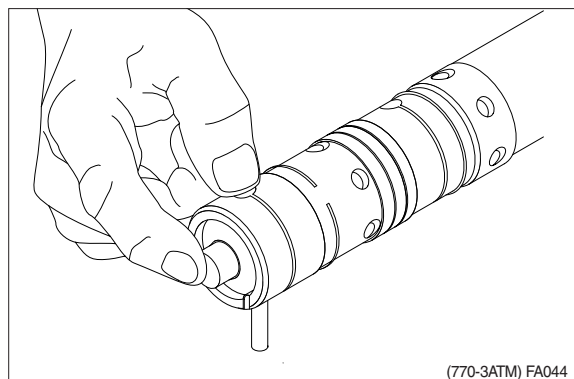

⑤ Take out plug.

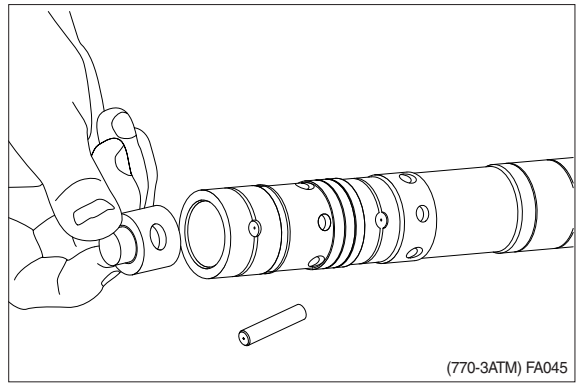

⑥ Take out spring.

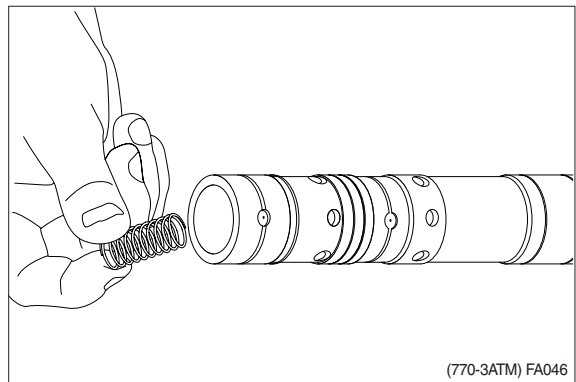

⑦ Take out pin 3mm screwdriver.

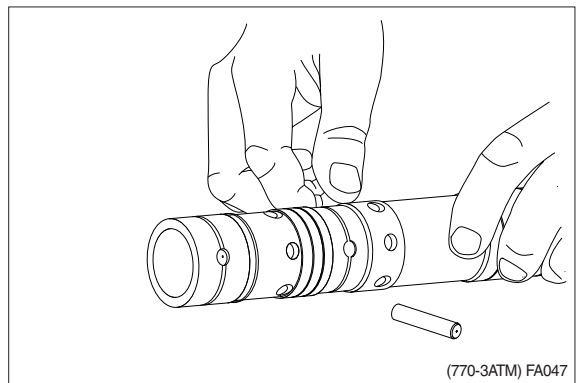

⑧ Take out inner spool.

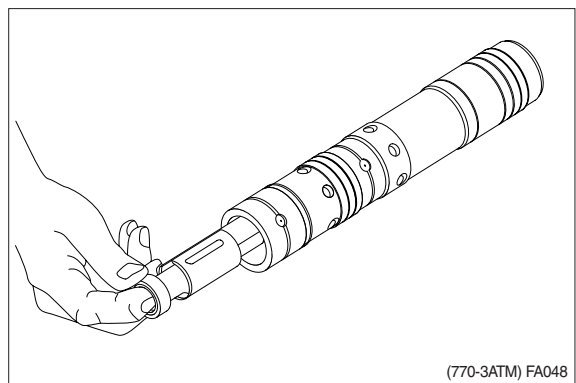

- ⑨ Unscrew check valve with hexagon socket for 17 mm external hexagon and mandrel in the pin hole.  
※ Avoid damaging the spool surface.

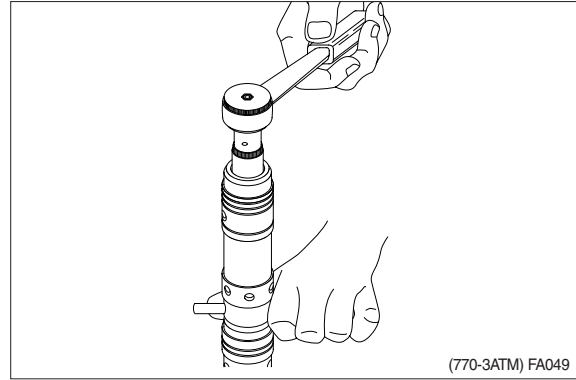

- ⑩ Unscrew orifice out of plug with 4 mm hexagon key. Use a mandrel.

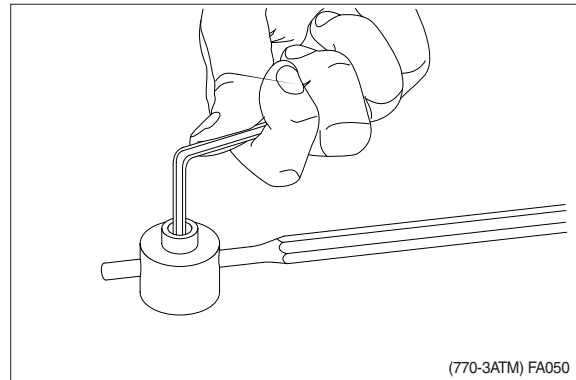

- ⑪ Amplifier spool shown disassembled.

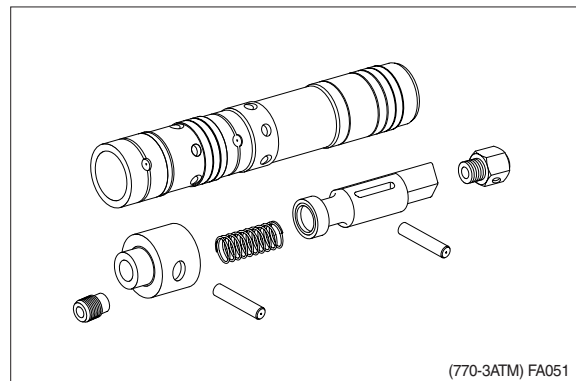

### (13) Disassembly of check valve

- ① Unscrew plug with 4 mm hexagon key and hexagon socket for 17 mm external hexagon.

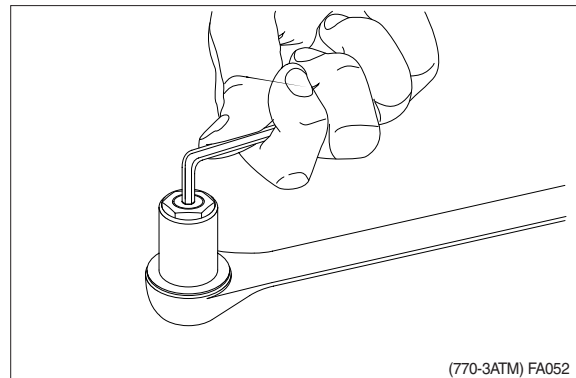

② Check valve shown disassembled.

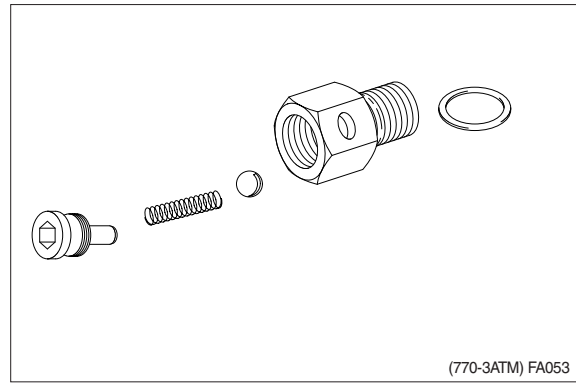

**(14) Disassembly of shock valve / suction valve**

- ① Unscrew locknut with hexagon socket for 13 mm external hexagon. Use a mandrel.
- ※ When readjusting shock valve hold locknut with 13 mm ring spanner.

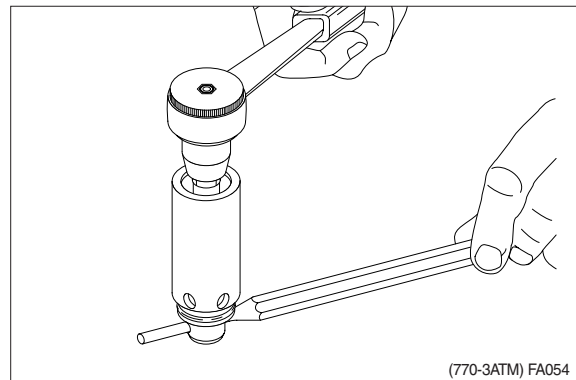

② Take out disc and spring.

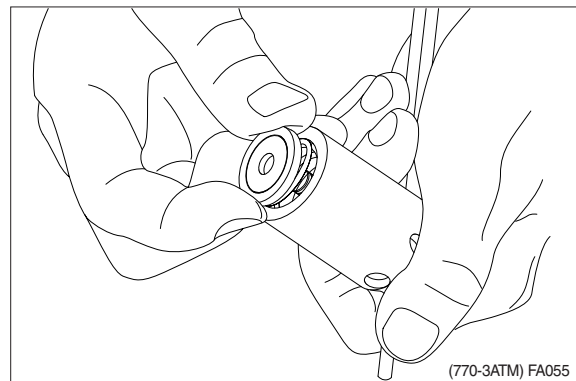

③ Take off housing.

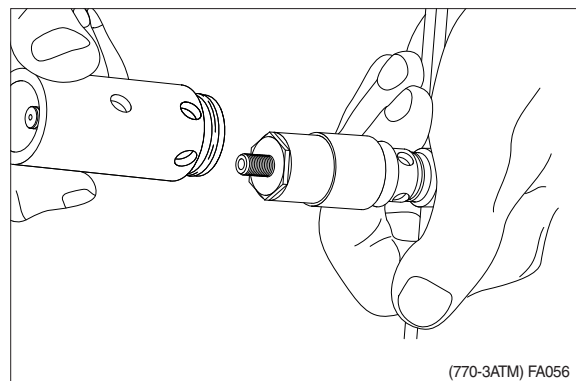

- ④ Unscrew pilot valve with hexagon socket for 19 mm external hexagon. Use a mandrel.

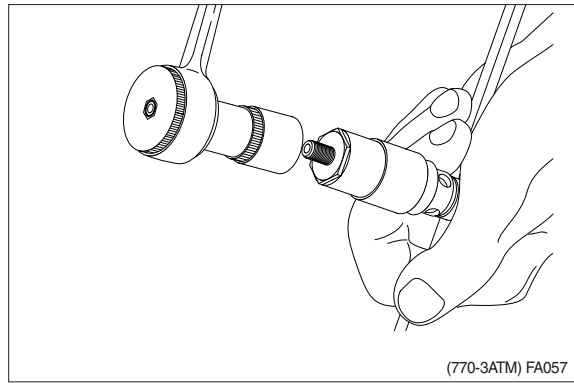

- ⑤ Take out pilot valve and spring.

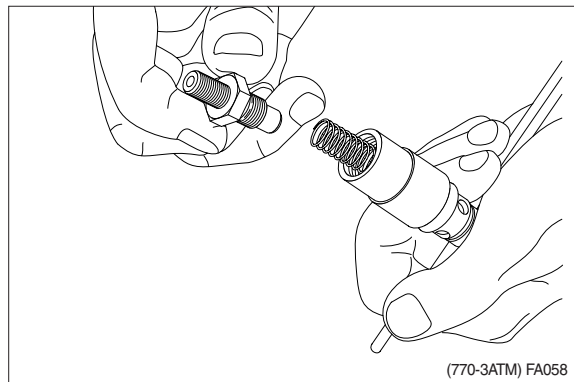

- ⑥ Take out spool.

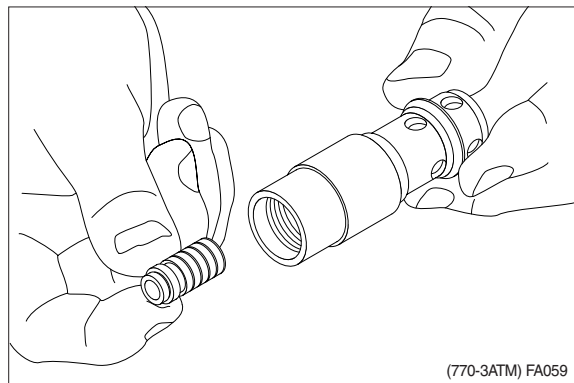

- ⑦ Unscrew adjustment screw and take out spring and ball.

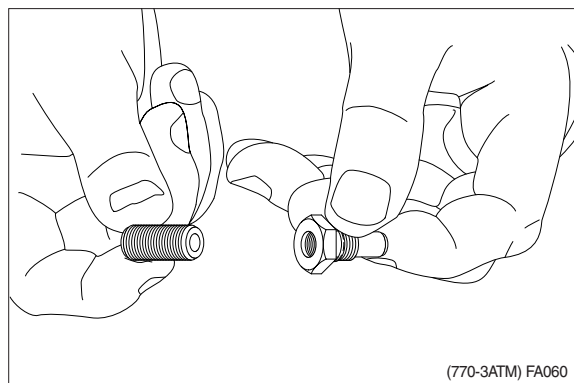

- ⑧ Shock valve / suction valve shown disassembled.

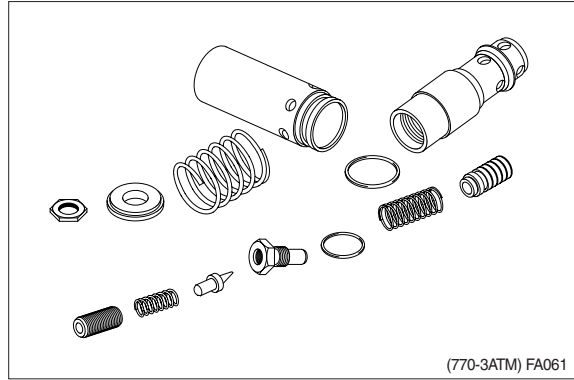

※ **Cleaning**

Clean all parts carefully with low aromatic kerosene.

※ **Inspection and replacement**

Replace all gaskets and sealing washers. Check all other parts carefully and replace if necessary.

※ **Lubrication**

Before assembly, lubricate all parts with hydraulic oil.

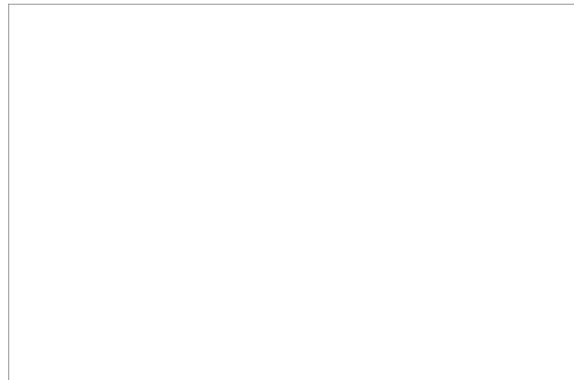

#### 4) ASSEMBLY

##### (1) Assembly of shock valve / suction valve

- ① Guide spring with cone into housing.

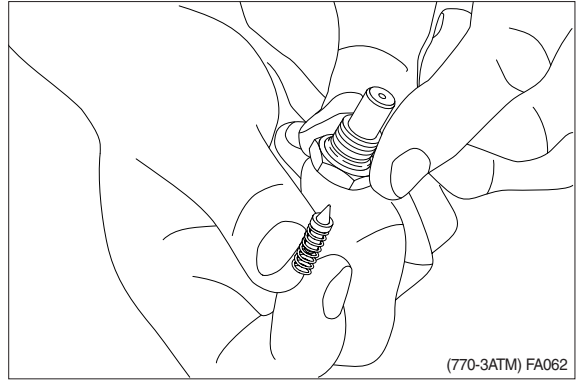

- ② Fit adjustment screw.

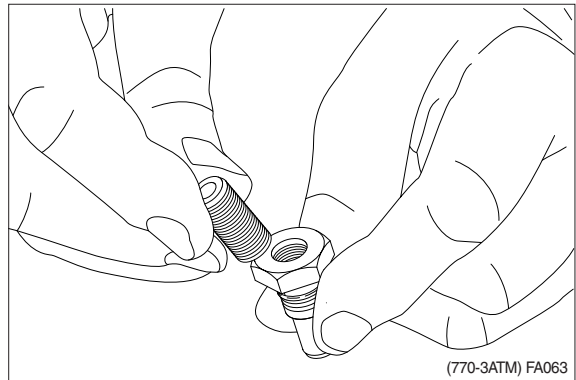

- ③ Fit spool.

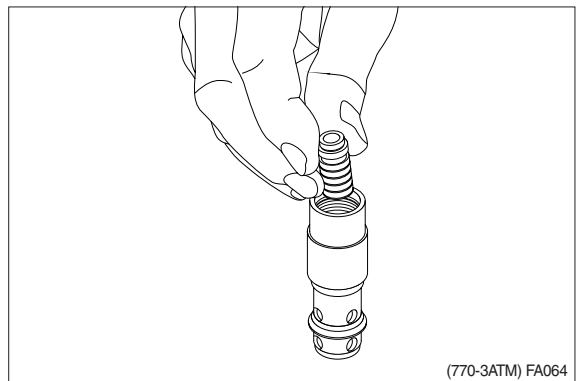

- ④ Fit spring.

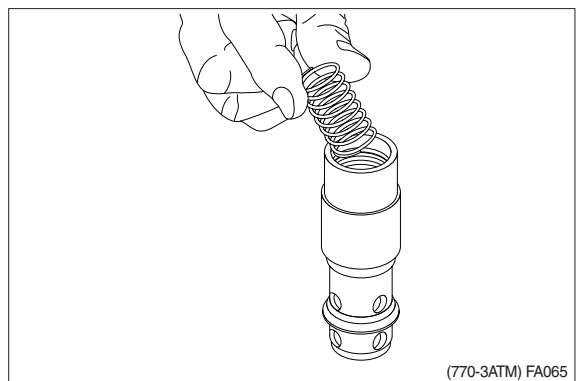

- ⑤ Fit pilot valve.  
Remember O-ring.

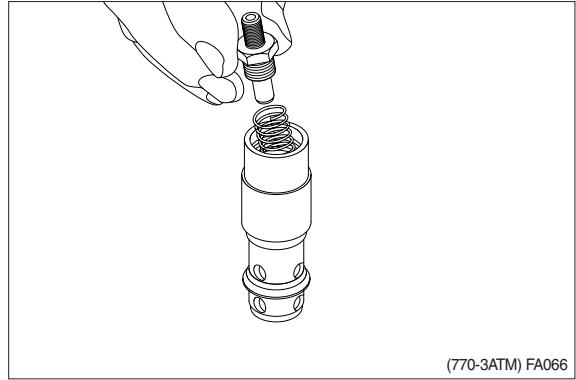

- ⑥ Tighten with torque wrench for 19 mm external hexagon. Use a mandrel.  
· Tightening torque :  $2 \pm 0.5$  kgf · m  
( $14.5 \pm 3.6$  lbf · ft)

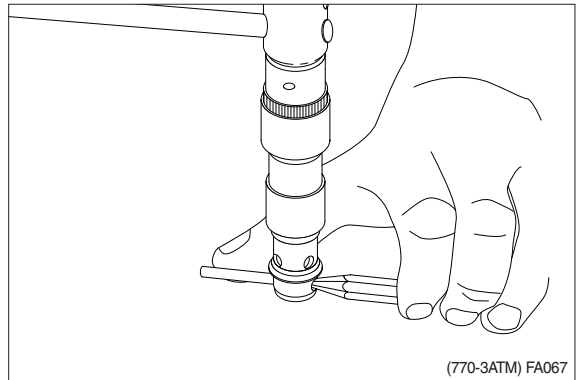

- ⑦ Fit housing.

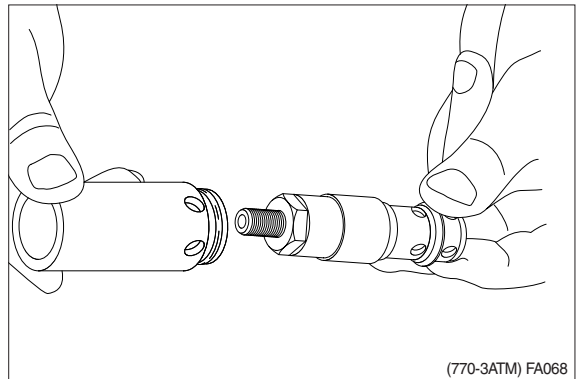

- ⑧ Fit spring.

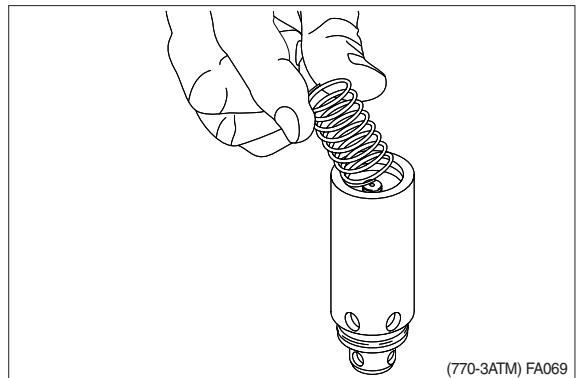

⑨ Fit disc.

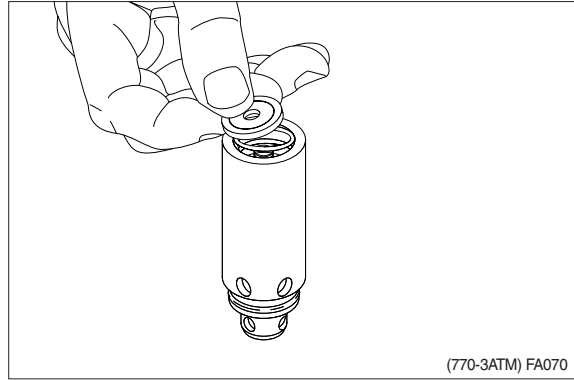

⑩ Fit locknut.

- Tightening torque :  $1.5 \pm 0.2$  kgf · m  
( $10.8 \pm 1.4$  lbf · ft)

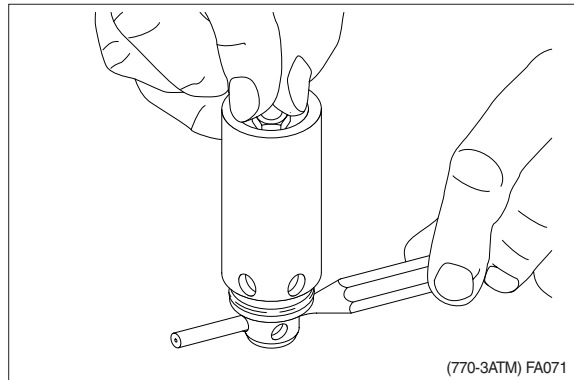

## (2) Assembly of check valve

① Fit ball, spring and plug.

- Tightening torque :  $0.5 \pm 0.1$  kgf · m  
( $3.6 \pm 0.7$  lbf · ft)

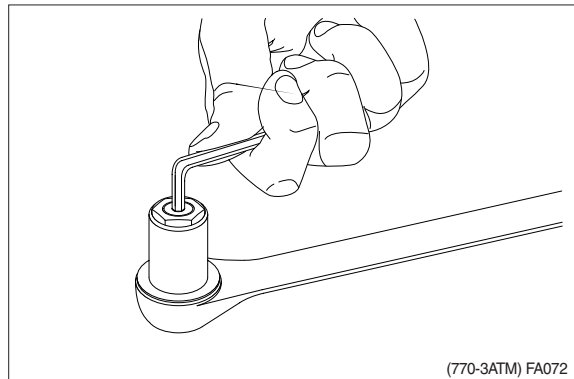

## (3) Assembly of amplifier spool

① Fit orifice in plug.

- Tightening torque :  $0.5 \pm 0.1$  kgf · m  
( $3.6 \pm 0.7$  lbf · ft)

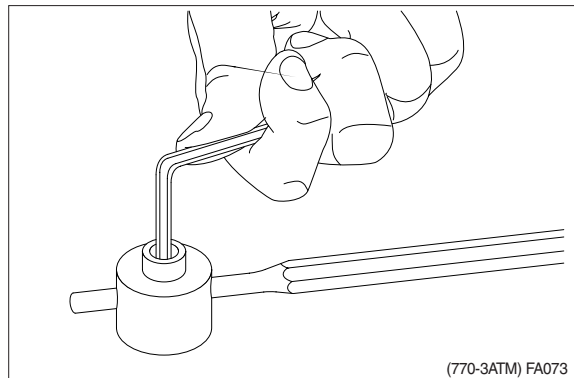

- ② Fit check valve.  
· Tightening torque :  $2 \pm 0.3 \text{ kgf} \cdot \text{m}$   
( $14.5 \pm 2.2 \text{ lbf} \cdot \text{ft}$ )  
※ Avoid damaging spool surface.  
Remember O-ring.

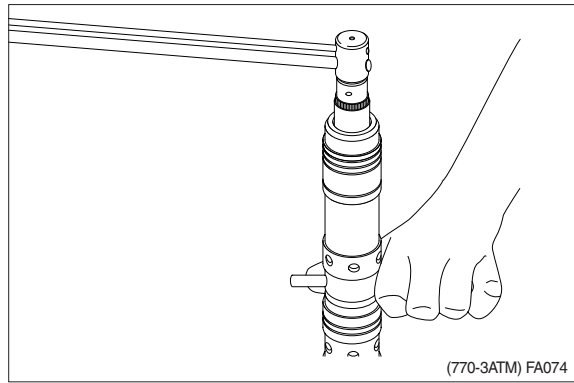

- ③ Place inner spool in the correct position.

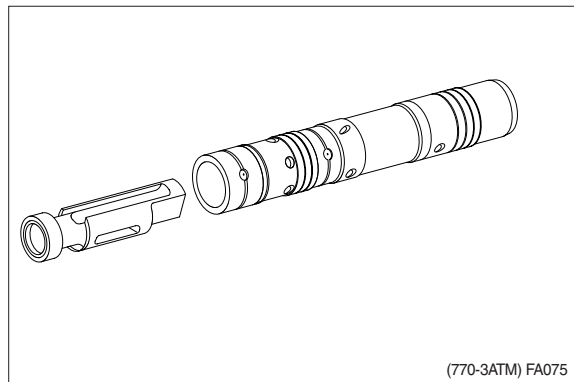

- ④ Guide inner spool in.

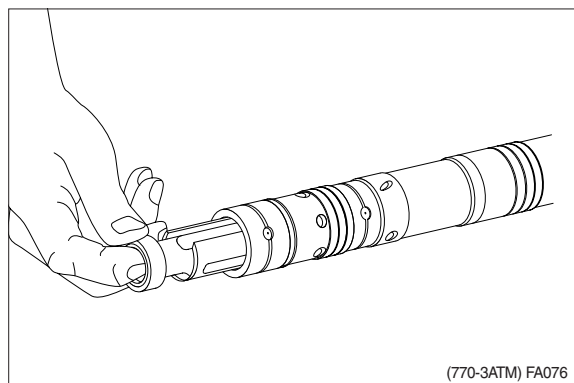

- ⑤ Fit pin.

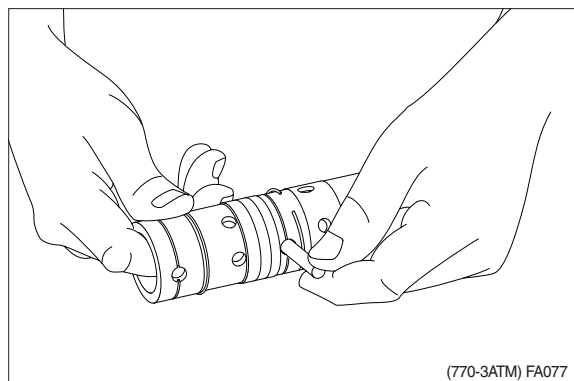

- ⑥ Push spring ring into position. Place spring ring into the recess with ends facing away from pin holes.

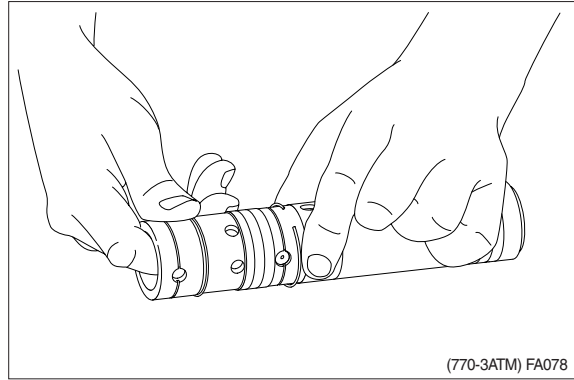

- ⑦ Fit spring.

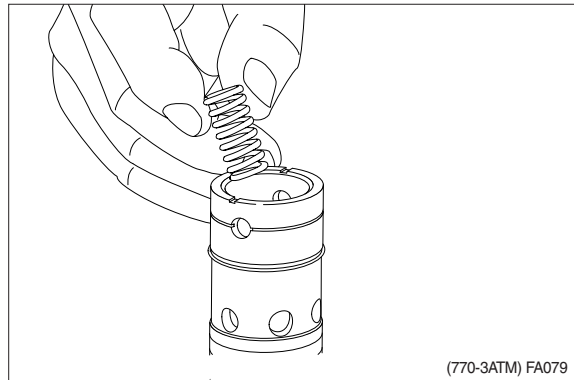

- ⑧ Fit plug.

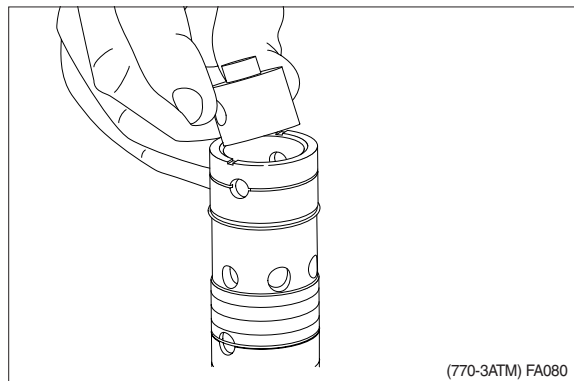

- ⑨ Fit pin.

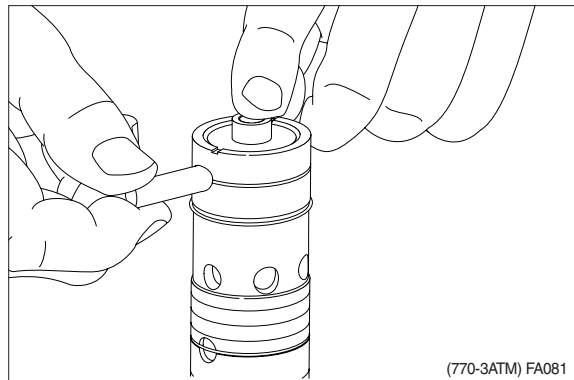

- ⑩ Push spring ring into position. Place spring ring into the recess with ends facing away from pin holes.

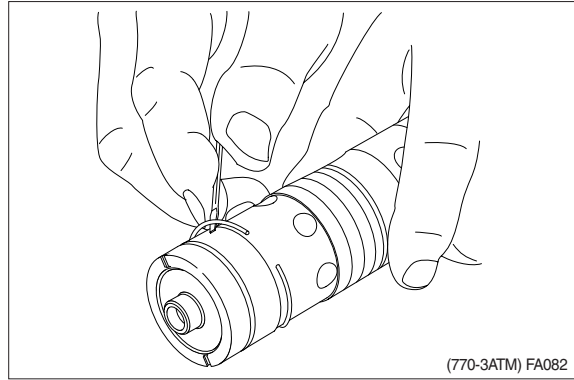

#### (4) Assembly of priority valve spool

- ① Fit plug or throttle check valve.  
External PP : Plug.  
Internal PP : Throttle check valve.  
· Tightening torque :  $1 \pm 0.3 \text{ kgf} \cdot \text{m}$   
( $7.2 \pm 2.2 \text{ lbf} \cdot \text{ft}$ )

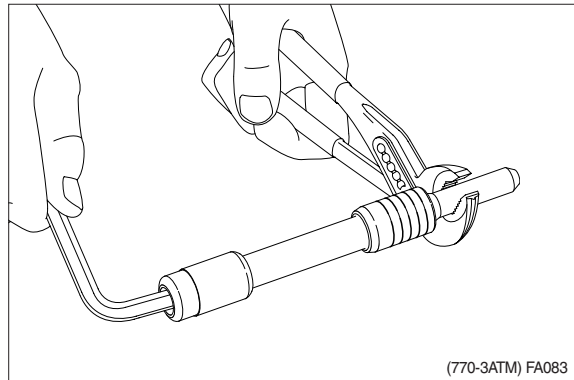

#### (5) Assembly of directional spool

- ① Screw in orifice.  
· Tightening torque :  $0.5 \pm 0.1 \text{ kgf} \cdot \text{m}$   
( $3.6 \pm 0.7 \text{ lbf} \cdot \text{ft}$ )

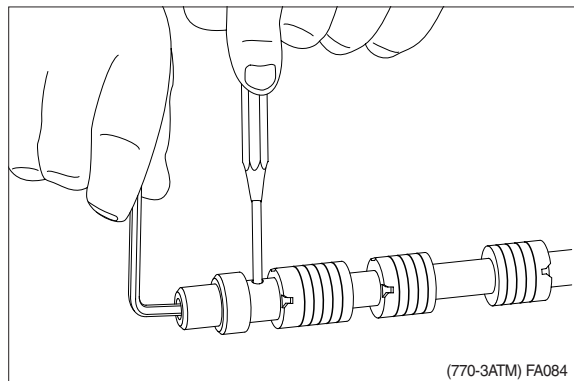

#### (6) Installation of orifice and throttle check valve

- ① Fit orifice in housing.  
· Tightening torque :  $0.5 \pm 0.1 \text{ kgf} \cdot \text{m}$   
( $3.6 \pm 0.7 \text{ lbf} \cdot \text{ft}$ )

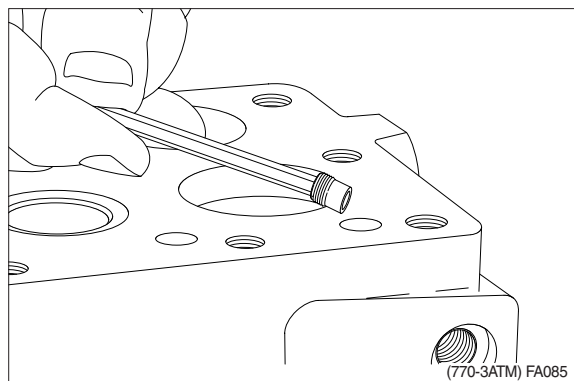

- ② Fit orifice in LS - connection.  
 · Tightening torque :  $1 \pm 0.3 \text{ kgf} \cdot \text{m}$   
 ( $7.2 \pm 2.2 \text{ lbf} \cdot \text{ft}$ )

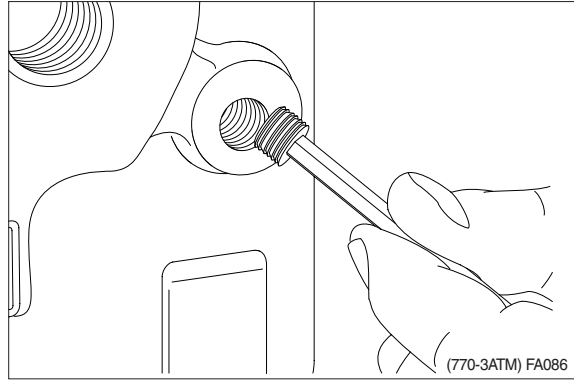

- ③ Fit throttle check valve in PP - connection.  
 · Tightening torque :  $1 \pm 0.3 \text{ kgf} \cdot \text{m}$   
 ( $7.2 \pm 2.2 \text{ lbf} \cdot \text{ft}$ )

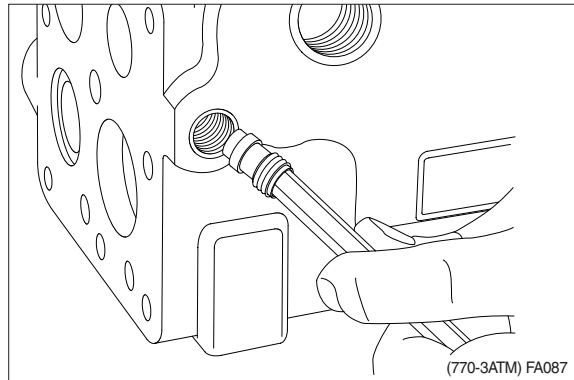

※ Comments on flow amplifiers with internal PP :

1. 1/4 BSP. F in PP - connection.

Fit washer and plug.

- Tightening torque :  $4.1 \pm 0.3 \text{ kgf} \cdot \text{m}$   
 ( $29.7 \pm 2.2 \text{ lbf} \cdot \text{ft}$ )

2. 7/16 - 20 UNF in PP - connection.

Fit O-ring and plug.

- Tightening torque :  $1.5 \pm 0.5 \text{ kgf} \cdot \text{m}$   
 ( $10.8 \pm 3.6 \text{ lbf} \cdot \text{ft}$ )

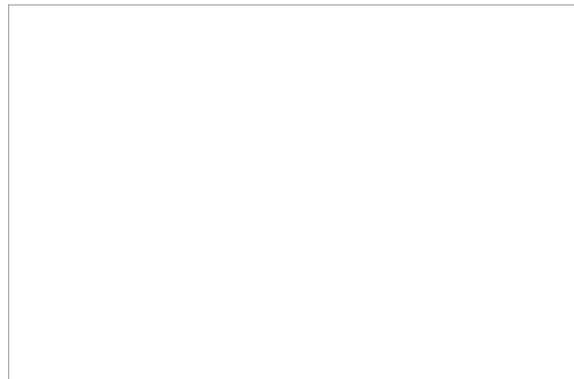

**(7) Installation of shock valves**

- ① Guide shock valve in and secure it by hand.  
 Remember O-ring.

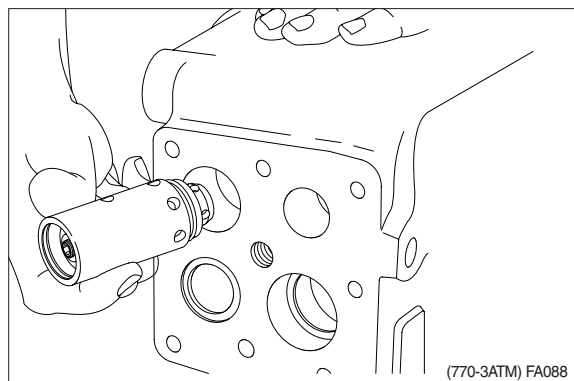

### (8) Assembly of pressure relief valve

- ① Guide adjustment screw, spring and cone up into the cartridge.

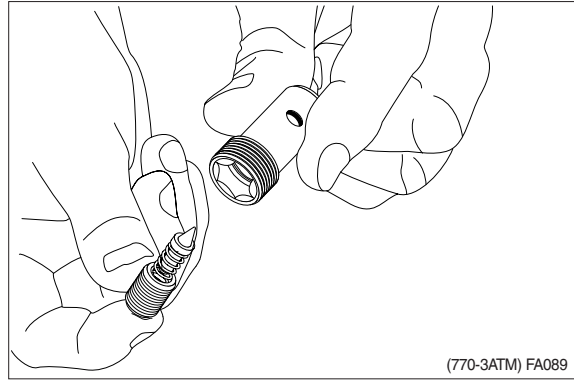

- ② Screw the adjustment screw so far in that the 10 mm hexagon key fully engages.

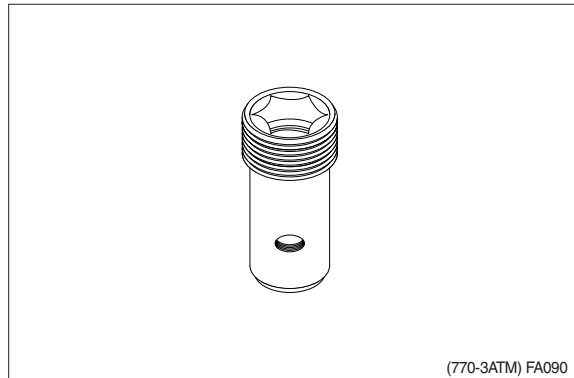

### (9) Installation of pressure relief valve

- ① Let the washer drop into the hole.

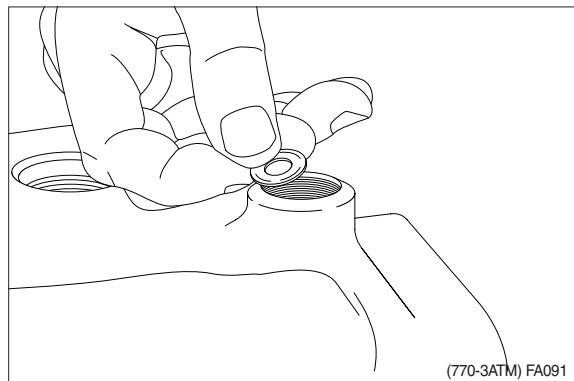

- ② Fit pressure relief valve.
  - Tightening torque :  $3.1 \pm 0.3 \text{ kgf} \cdot \text{m}$   
( $22.4 \pm 2.2 \text{ lbf} \cdot \text{ft}$ )

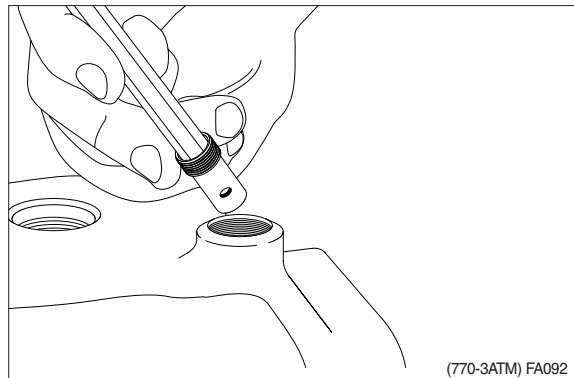

- ③ Fit plug with washer.  
 · Tightening torque :  $6 \pm 0.5 \text{ kgf} \cdot \text{m}$   
 ( $44.1 \pm 3.6 \text{ lbf} \cdot \text{ft}$ )

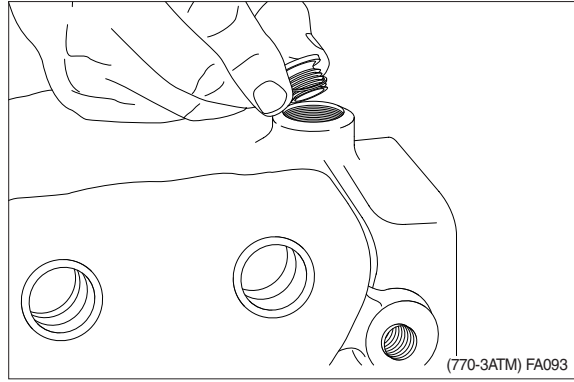

**(10) Installation of back pressure valve**

- ① First fit spring in piston with vaseline.  
 Fit assembled piston and spring.

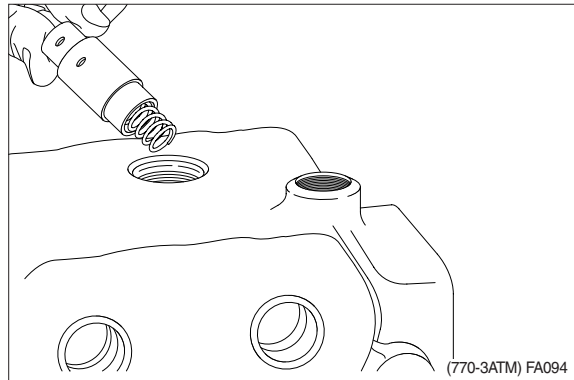

- ② Let the ball drop down.

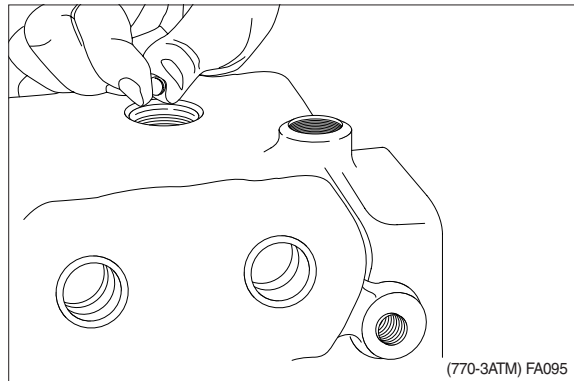

- ③ Fit spring in plug with vaseline.  
 Fit assembled plug and spring.  
 Remember O-ring.  
 · Tightening torque :  $2.6 \pm 0.3 \text{ kgf} \cdot \text{m}$   
 ( $18.8 \pm 2.2 \text{ lbf} \cdot \text{ft}$ )

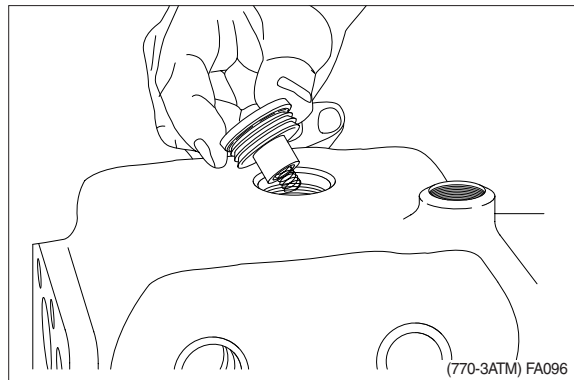

### (11) Installation of spools

- ① Fit directional spool.  
Fit priority valve spool.  
※ Spring control must be placed in correct position against LS - connection.

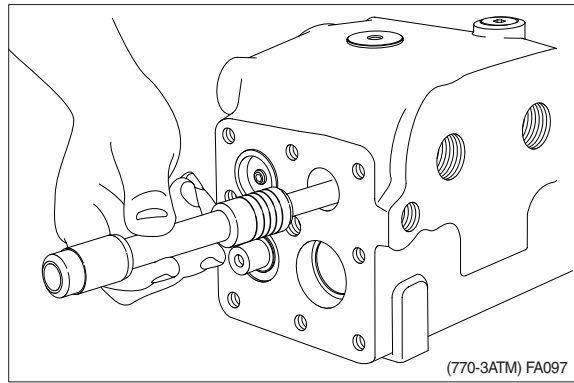

- ② Fit spring.  
※ Spring must be by the LS - connection.

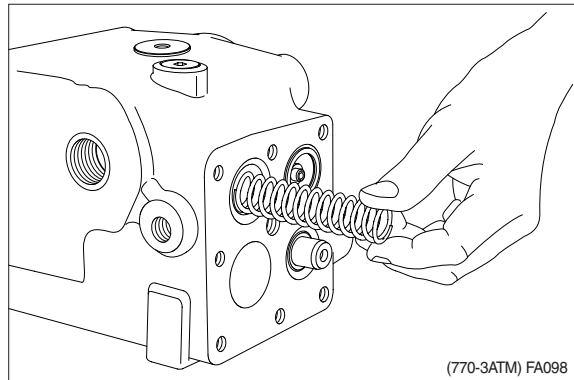

- ③ Fit amplifier spool.  
※ The orifice must be placed in correct position against LS - connection.

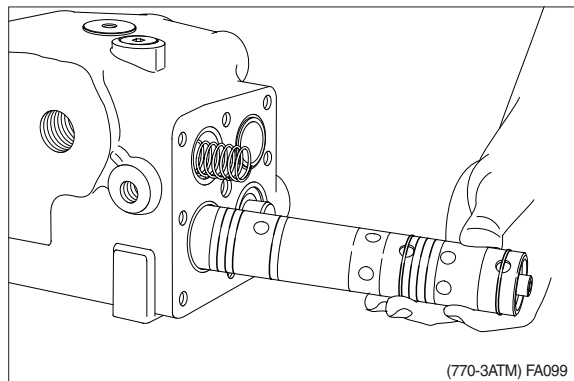

### (12) Installation of end cover at PP - connection

- ① Fit spring with vaseline on amplifier  
※ spool.  
The spring must be fitted at the PP - connection.

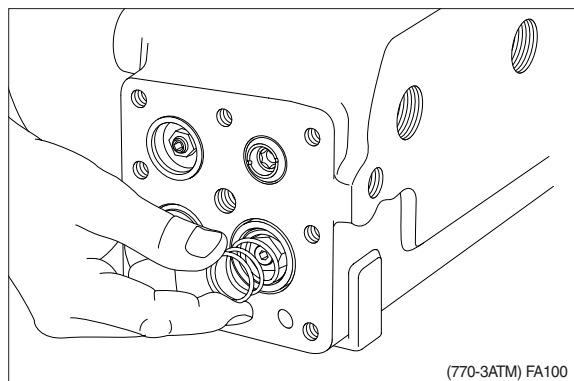

② Fit spring guide with vaseline.

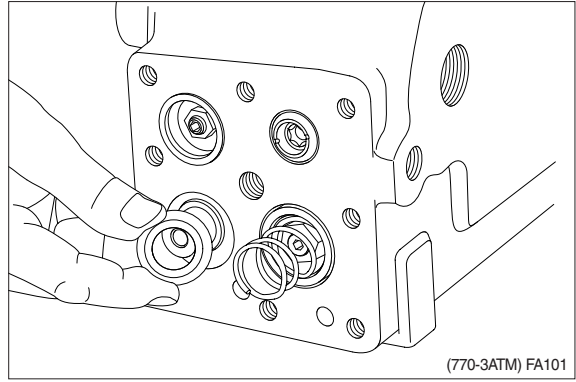

③ Fit large and small springs with vaseline.

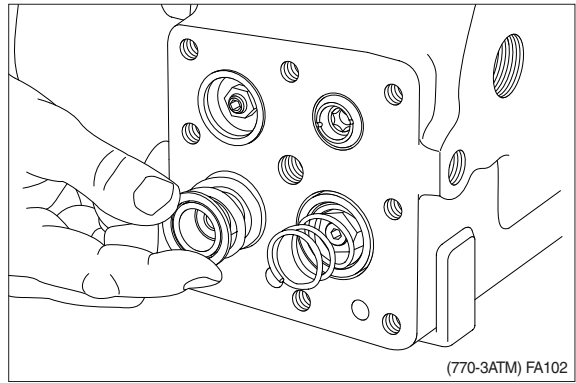

④ Fit guide screws.

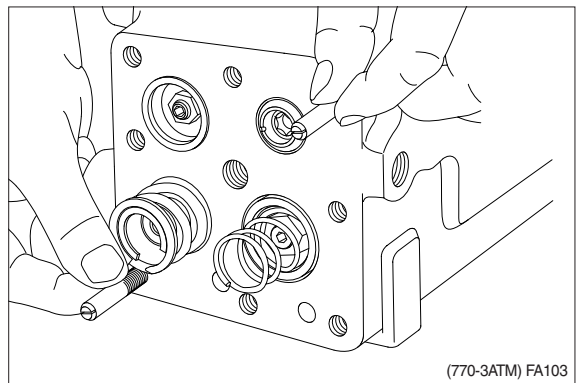

⑤ Fit 4 large and 2 small O-rings.

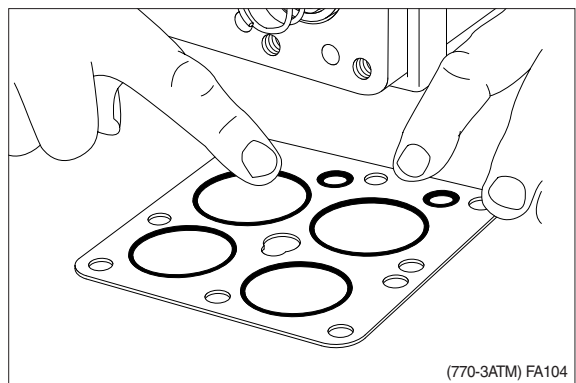

⑥ Guide plate in.

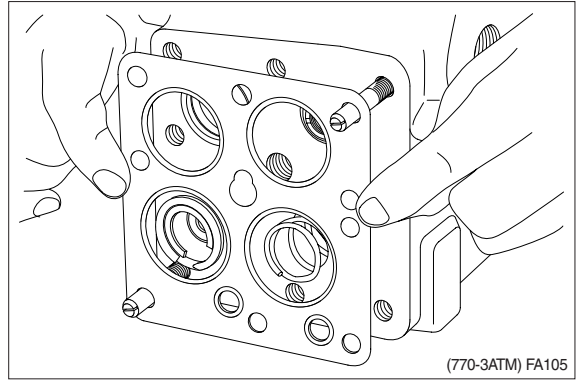

⑦ Fit stop (thickness : 5 mm) in end cover with vaseline.

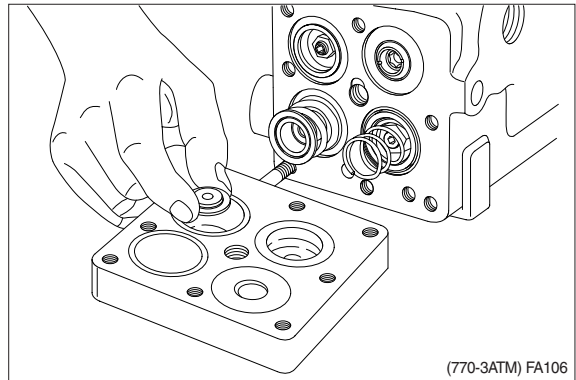

⑧ Guide end cover in.

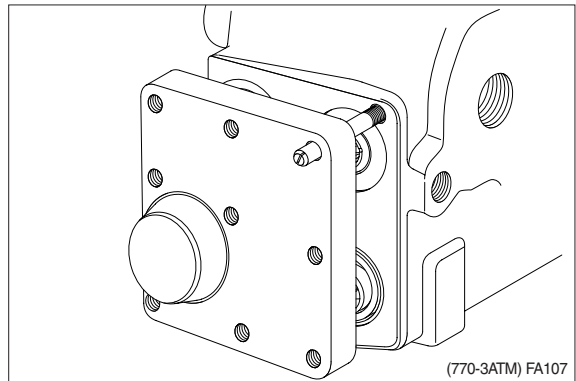

⑨ Fit screw with spring washer.

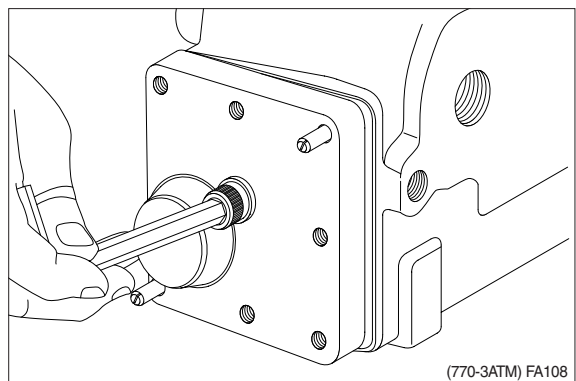

- ⑩ Fit screws with spring washer.
- Tightening torque :  $2.6 \pm 0.5 \text{ kgf} \cdot \text{m}$   
( $18.8 \pm 3.6 \text{ lbf} \cdot \text{ft}$ )
  - Tightening torque :  $8.2 \pm 1 \text{ kgf} \cdot \text{m}$   
for large screw ( $59.3 \pm 7.2 \text{ lbf} \cdot \text{ft}$ )

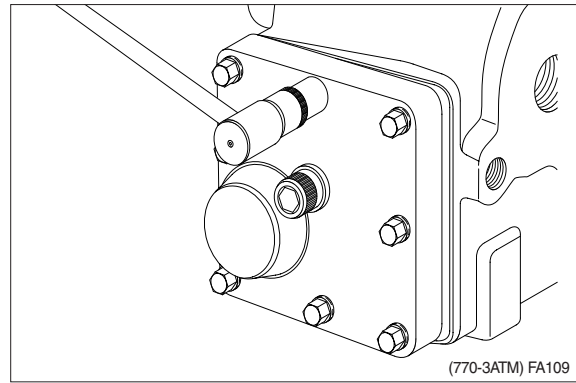

**(13) Installation of end cover at LS - connection**

- ① Fit guide screws.  
Fit remote control with vaseline.

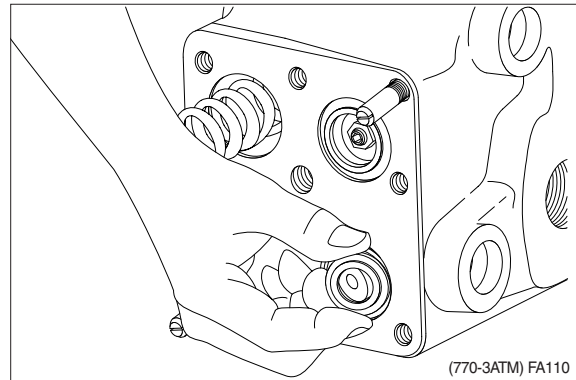

- ② Fit large and small springs with vaseline.

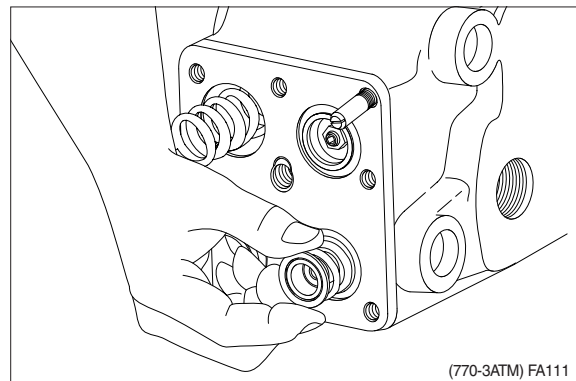

- ③ Guide in plate with 4 O-rings.

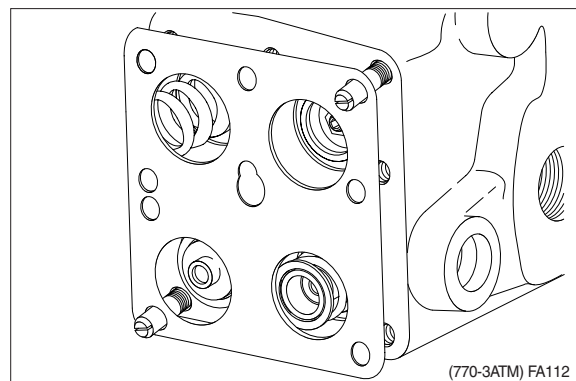

- ④ Fit stop for priority valve spool (thickness : 8 mm) with vaseline.

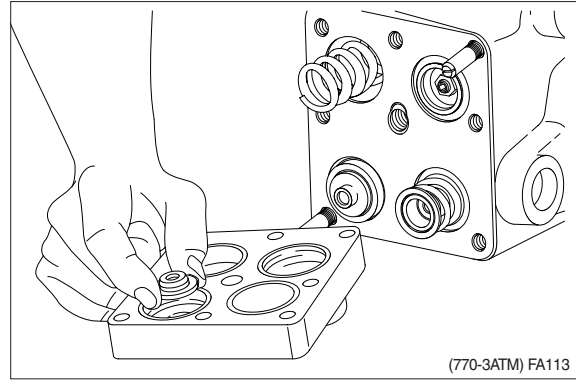

- ⑤ Fit stop for directional spool (thickness : 5 mm) with vaseline.

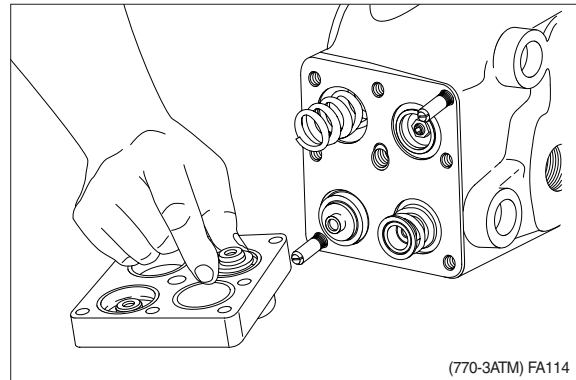

- ⑥ Guide in end cover.

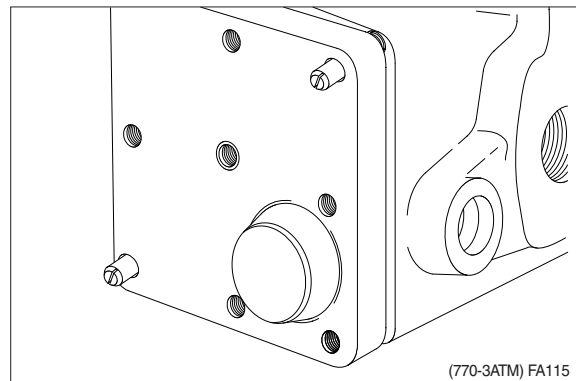

- ⑦ Fit large screw with spring washer.

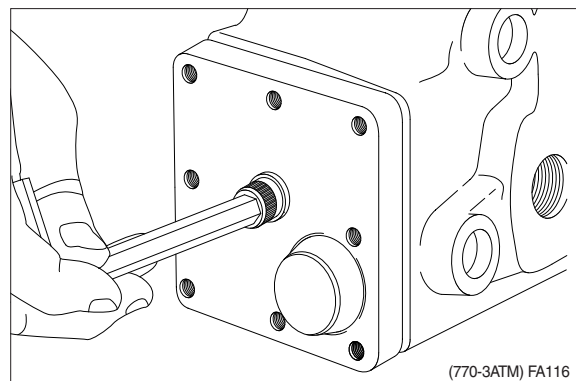

- ⑧ Fit screws with spring washers.
- Tightening torque :  $2.6 \pm 0.5 \text{ kgf} \cdot \text{m}$   
( $18.8 \pm 3.6 \text{ lbf} \cdot \text{ft}$ )
  - Tightening torque :  $8.2 \pm 1 \text{ kgf} \cdot \text{m}$   
for large screw ( $59.3 \pm 7.2 \text{ lbf} \cdot \text{ft}$ )

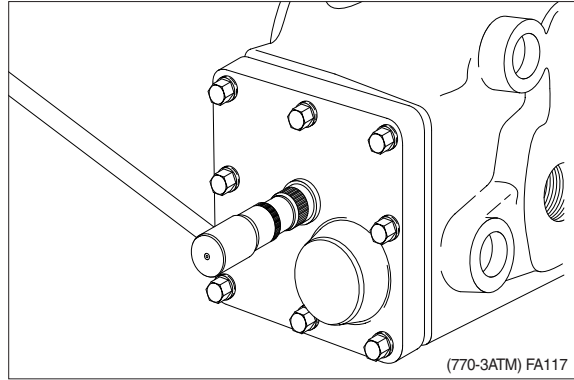

- ⑨ Fit plastic plugs.

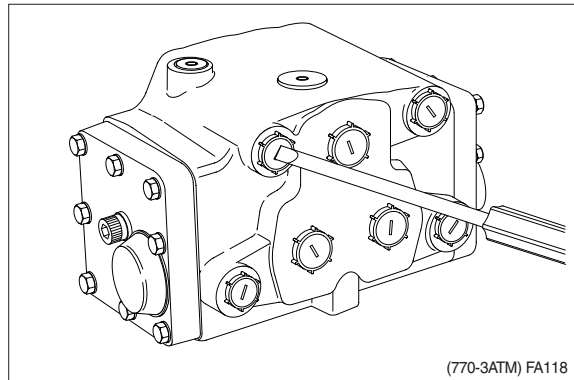

This completes assembly.

## 2. STEERING UNIT

### 1) STRUCTURE

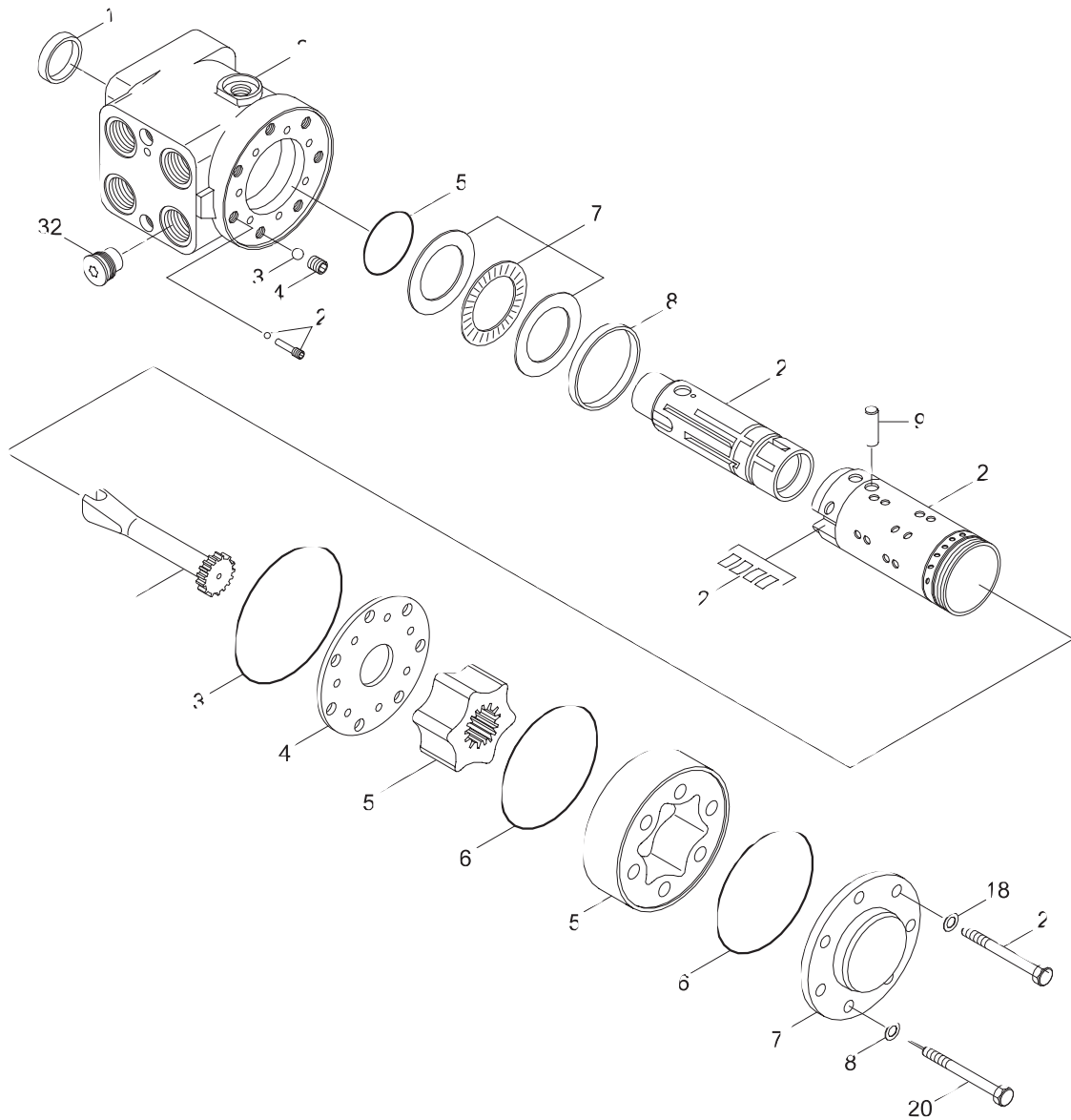

7707SE21

- |   |                        |    |                   |    |             |
|---|------------------------|----|-------------------|----|-------------|
| 1 | Dust seal ring         | 9  | Cross pin         | 17 | End cover   |
| 2 | Housing, Spool, sleeve | 11 | Shaft             | 18 | Washer      |
| 3 | Ball                   | 12 | Spring set        | 20 | Pin screw   |
| 4 | Bushing                | 13 | O-ring            | 21 | Screw       |
| 5 | Lip seal               | 14 | Distributor plate | 32 | Check valve |
| 7 | Bearing assy           | 15 | Gearwheel set     |    |             |
| 8 | Ring                   | 16 | O-ring            |    |             |

## 2) TOOLS

(1) Holding tool.

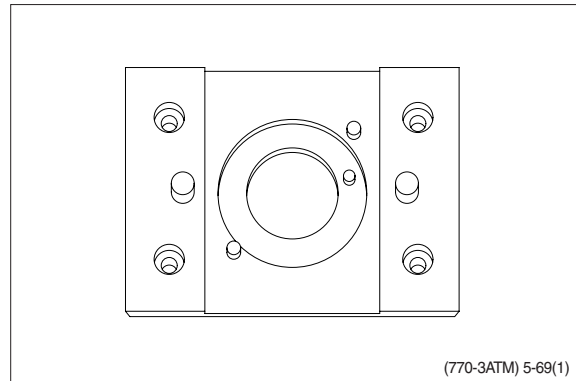

(2) Assembly tool for O-ring and kin-ring.

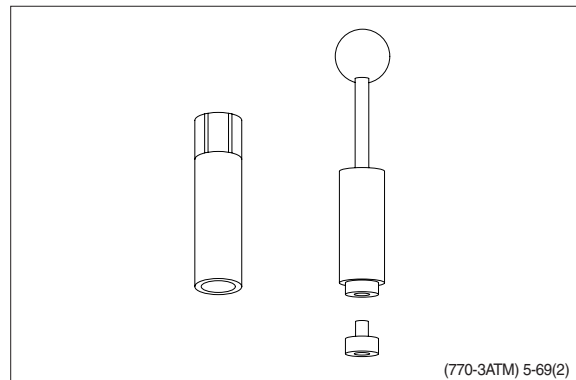

(3) Assembly tool for lip seal.

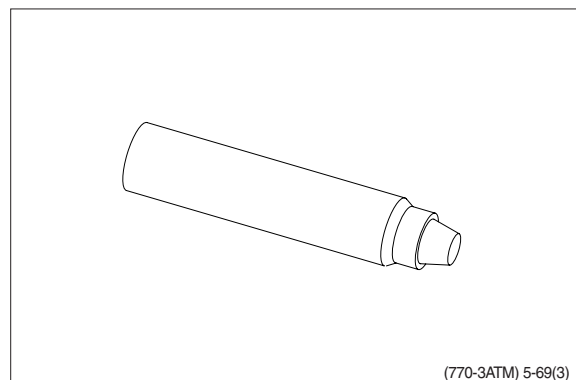

(4) Assembly tool for cardan shaft.

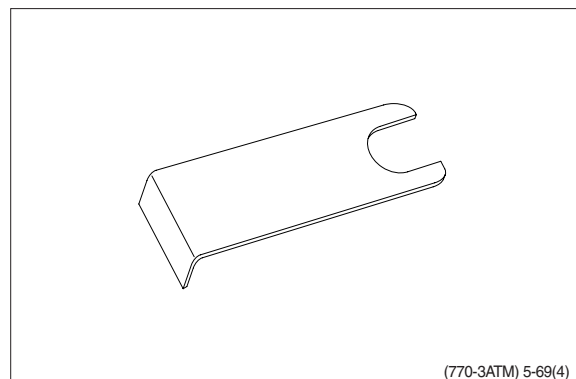

(5) Assembly tool for dust seal.

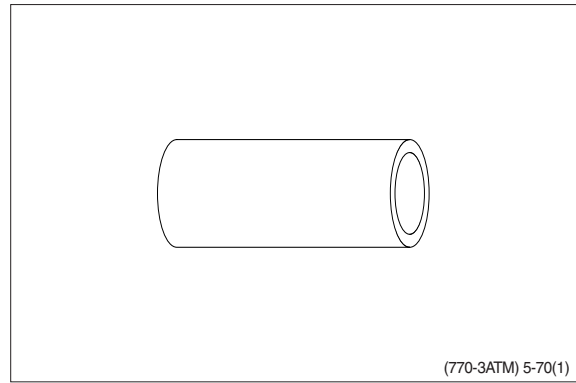

- (6) Torque wrench 0~7.1 kgf · m  
(0~54.4 lbf · ft)
- 13 mm socket spanner
  - 6, 8 mm and 12 mm hexagon sockets
  - 12 mm screwdriver
  - 2 mm screwdriver
  - 13 mm ring spanner
  - 6, 8 and 12 mm hexagon socket spanners
  - Plastic hammer
  - Tweezers

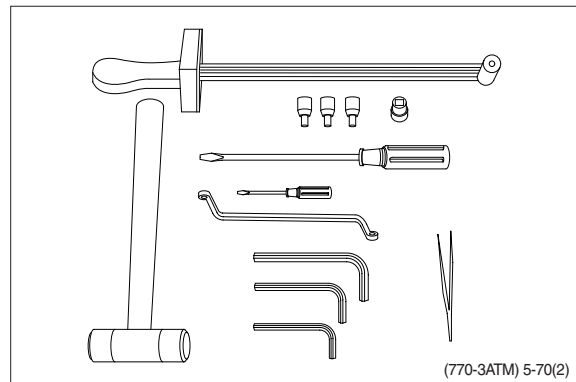

### 3) TIGHTENING TORQUE AND HYDRAULIC CONNECTIONS

#### (1) Hydraulic connections

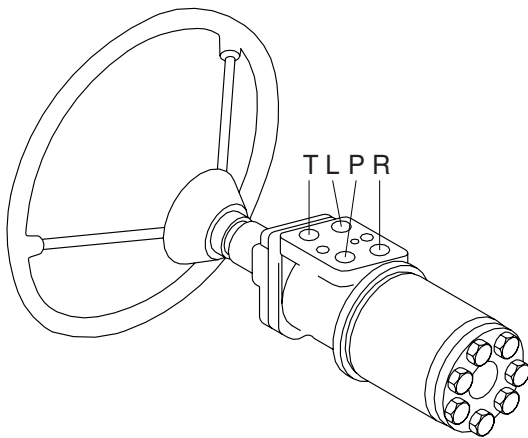

L : Left port  
 R : Right port  
 T : Tank  
 P : Pump

(770-3ATM) 5-71

#### (2) Tightening torque

Screwed connection	Max. tightening torque [ kgf · m (lbf · ft) ]			
	With cutting edge	With copper washer	With aluminum washer	With O - ring
1/4 BSP.F	4.1 (29.7)	2.0 (14.5)	3.1 (22.4)	-
3/8 BSP.F	6.1 (44.1)	2.0 (14.5)	5.1 (36.9)	-
1/2 BSP.F	10.2 (73.8)	3.1 (22.4)	8.2 (59.3)	-
7/16-20 UNF	-	-	-	2.0 (14.5)
3/4-16 UNF	-	-	-	6.1 (44.1)
M 12×1.5	4.1 (29.7)	2.0 (14.5)	3.1 (22.4)	2.0 (14.5)
M 18×1.5	7.1 (51.4)	2.0 (14.5)	5.1 (36.9)	5.1 (36.9)
M 22×1.5	10.2 (73.8)	3.1 (22.4)	8.2 (59.3)	7.1 (51.4)

#### 4) DISASSEMBLY

- (1) Disassemble steering column from steering unit and place the steering unit in the holding tool.  
Screw out the screws in the end cover(6-off plus one special screw).

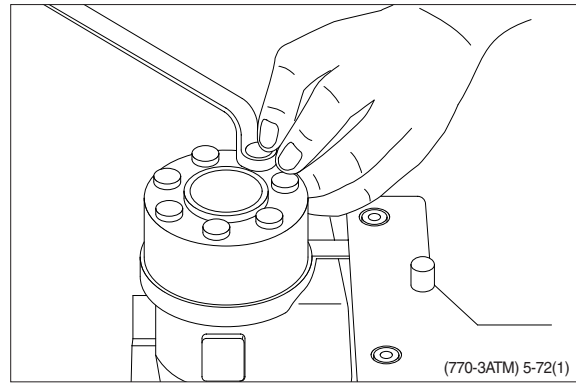

- (2) Remove the end cover, sideways.

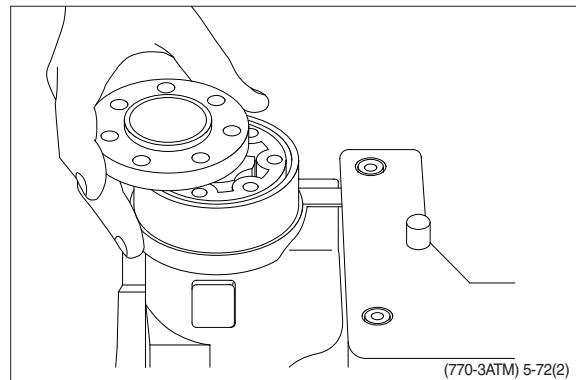

- (3) Lift the gearwheel set (with spacer if fitted) off the unit.  
Take out the two O-rings.

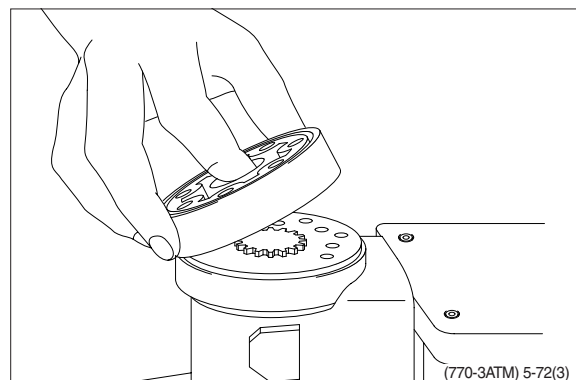

- (4) Remove cardan shaft.

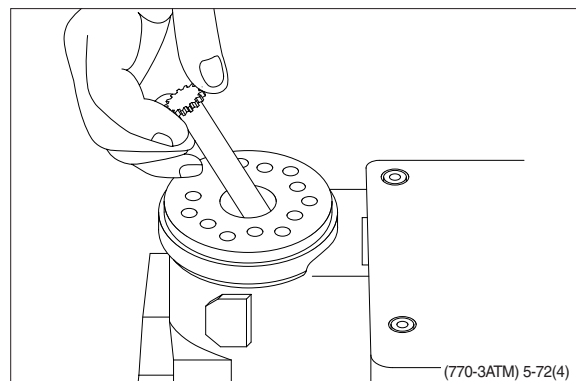

(5) Remove distributor plate.

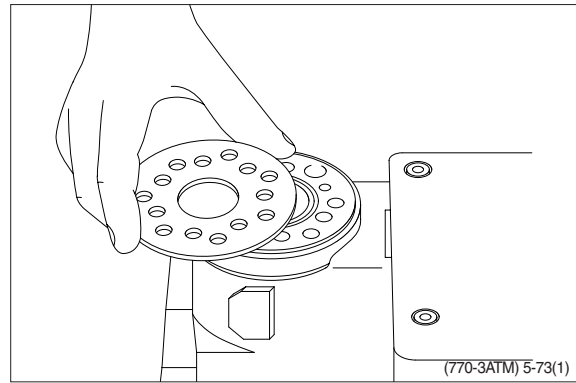

(6) Screw out the threaded bush over the check valve.

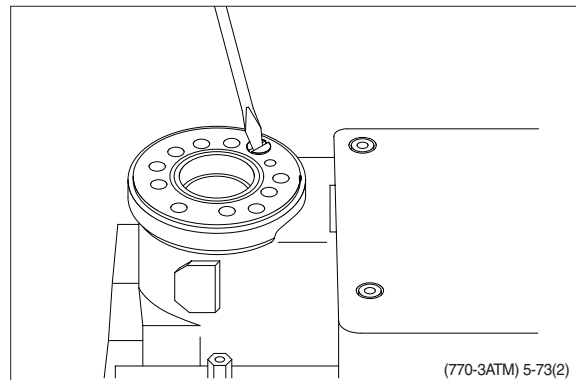

(7) Remove O-ring.

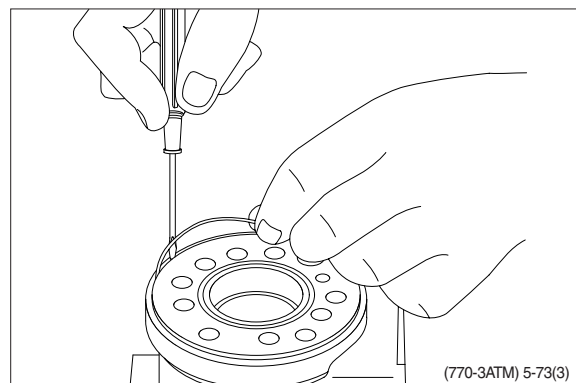

(8) Take care to keep the cross pin in the sleeve and spool horizontal. The pin can be seen through the open end of the spool. Press the spool inwards and the sleeve, ring, bearing races and needle bearing will be pushed out of the housing together.

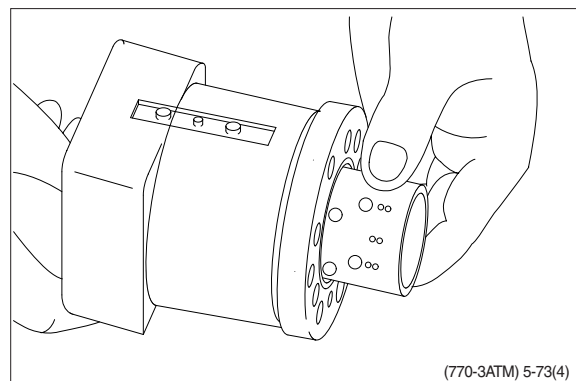

- (9) Take ring, bearing races and needle bearing from sleeve and spool. The outer (Thin) bearing race can sometimes "stick" in the housing, therefore check that it has come out.

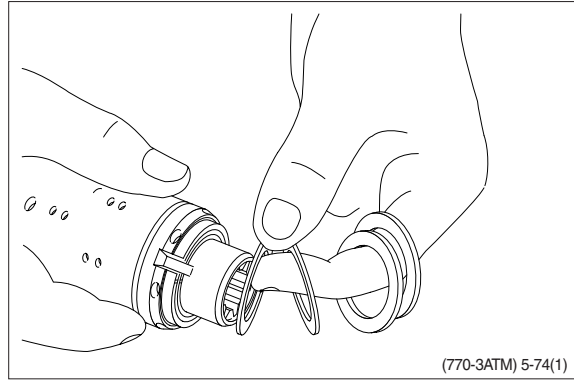

- (10) Press out the cross pin. Use the special screw from the end cover.

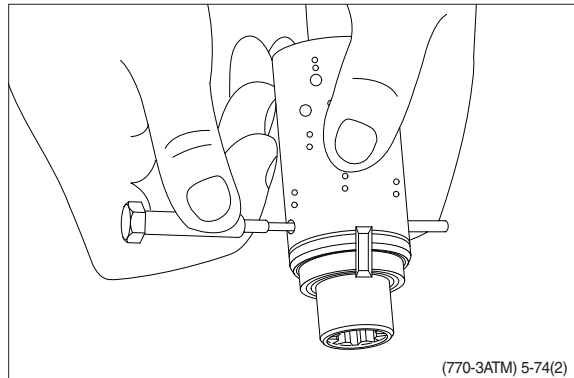

- ※ A small mark has been made with a pumice stone on both spool and sleeve close to one of the slots for the neutral position springs (see drawing). If the mark is not visible, remember to leave a mark of your own on sleeve and spool before the neutral position springs are disassembled.

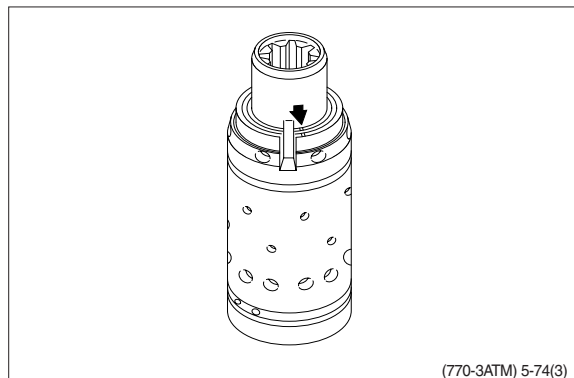

- (11) Carefully press the spool out of the sleeve.

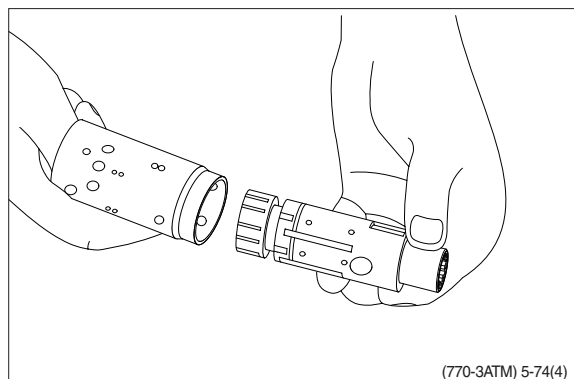

(12) Press the neutral position springs out of their slots in the spool.

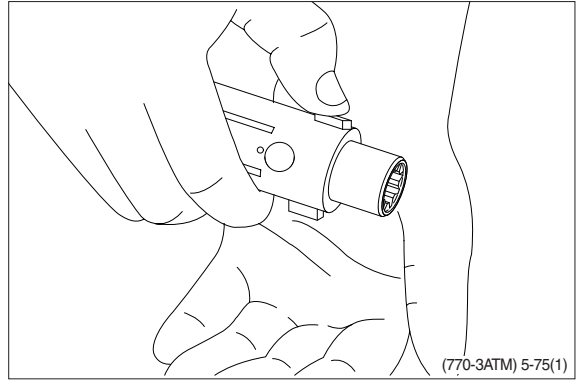

(13) Remove dust seal and O-ring.

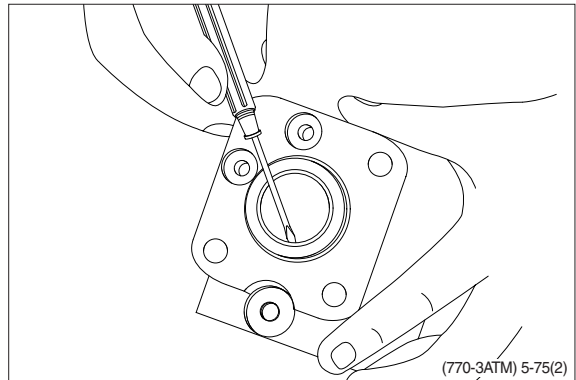

(14) The steering unit is now completely disassembled.

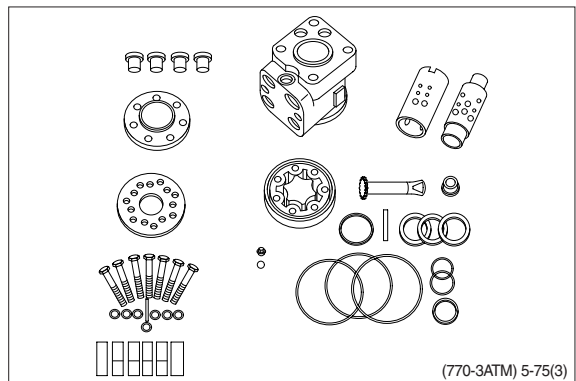

※ **Cleaning**

Clean all parts carefully in Shellsol K or the like.

※ **Inspection and replacement**

Replace all seals and washers. Check all parts carefully and make any replacements necessary.

※ **Lubrication**

Before assembly, lubricate all parts with hydraulic oil.

## 5) ASSEMBLY

(1) Assemble spool and sleeve.

- ※ When assembling spool and sleeve only one of two possible ways of positioning the spring slots is correct. There are three slots in the spool and three holes in the sleeve in the end of the spool / sleeve opposite to the end with spring slots. Place the slots and holes opposite each other so that parts of the holes in the sleeve are visible through the slots in the spool.

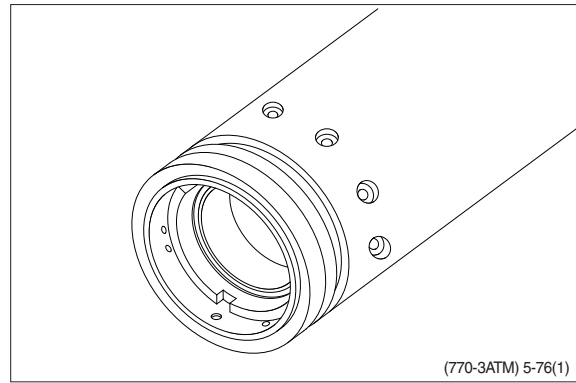

(2) Place the two flat neutral position springs in the slot.

Place the curved springs between the flat ones and press them into place (see assembly pattern).

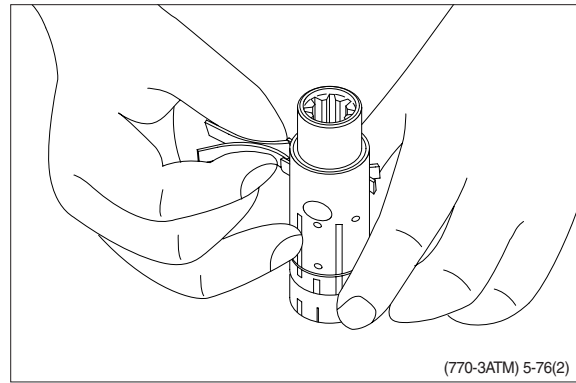

※ Assembly pattern.

- Weak springs (blue)
  - 2 - off flat, blue : Part no. 150-0748
  - 2 - off curved, blue : Part no. 150-0749
- Blue set
  - Spare set : Part no. 150-4265

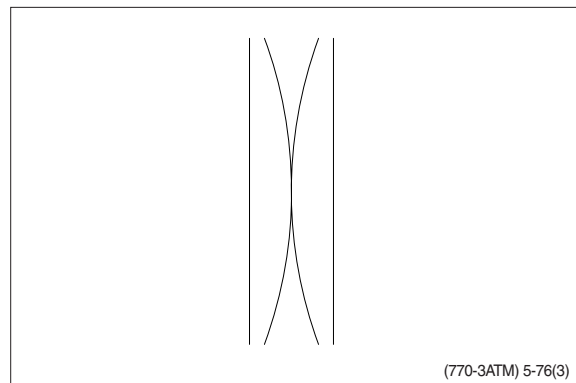

(3) Line up the spring set.

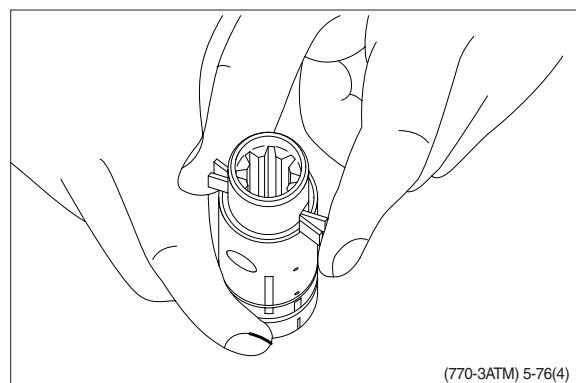

- (4) Guide the spool into the sleeve. Make sure that spool and sleeve are placed correctly in relation to each other(See page 3-76, No.(1)).

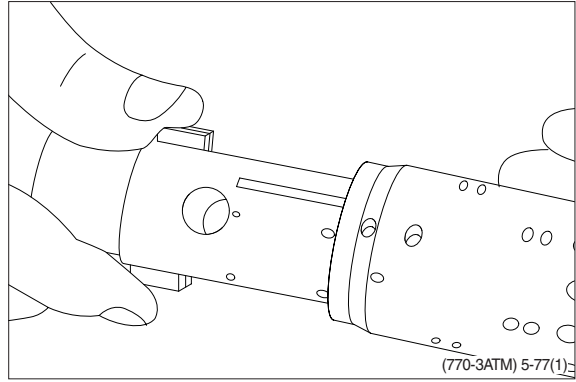

- (5) Press the springs together and push the neutral position springs into place in the sleeve.

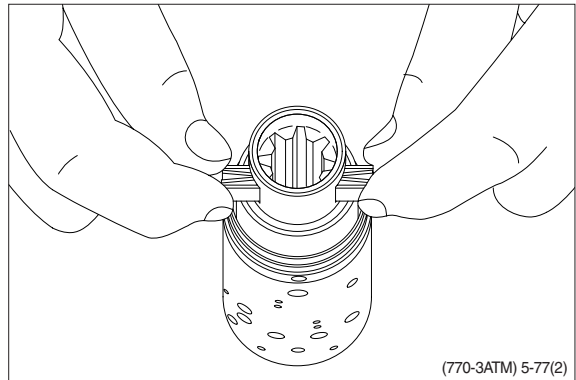

- (6) Line up the springs and center them.

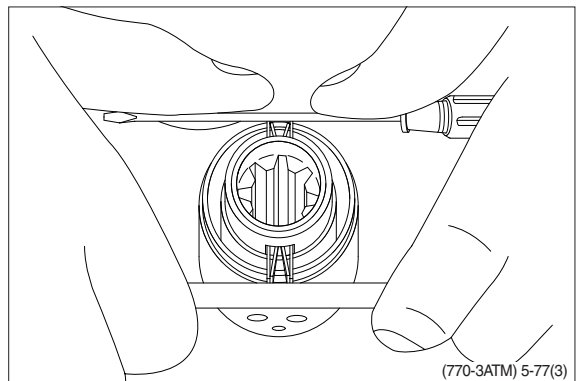

- (7) Guide the ring down over the sleeve.  
※ The ring should be able to rotate free of the springs.

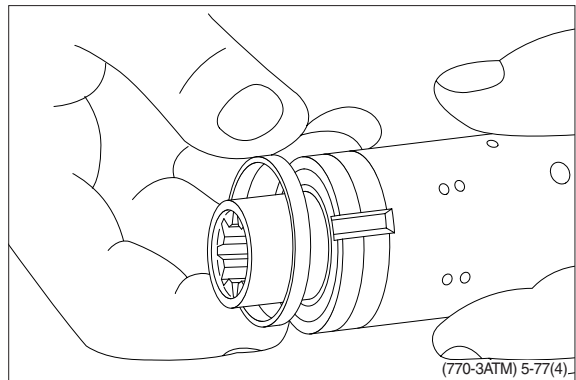

(8) Fit the cross pin into the spool / sleeve.

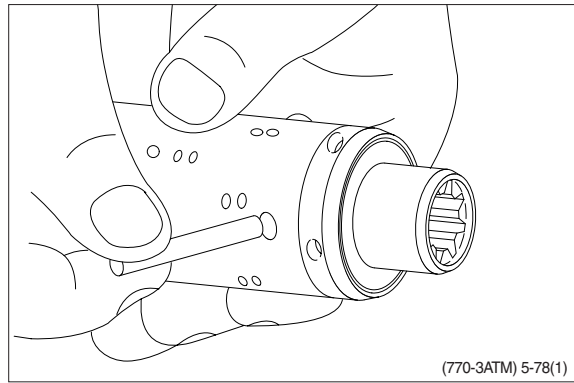

(9) Fit bearing races and needle bearing as shown on below drawing.

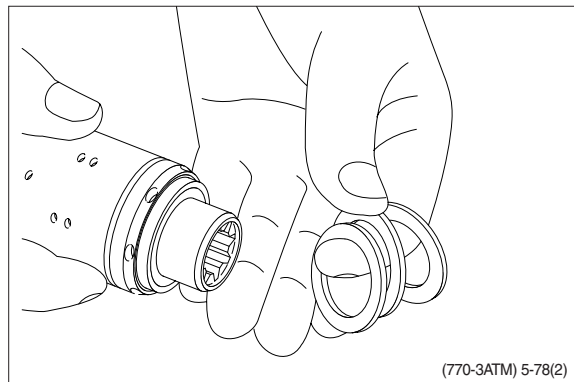

※ Assembly pattern for standard bearings

- 1 Outer bearing race
- 2 Needle bearing
- 3 Inner bearing race
- 4 Spool
- 5 Sleeve

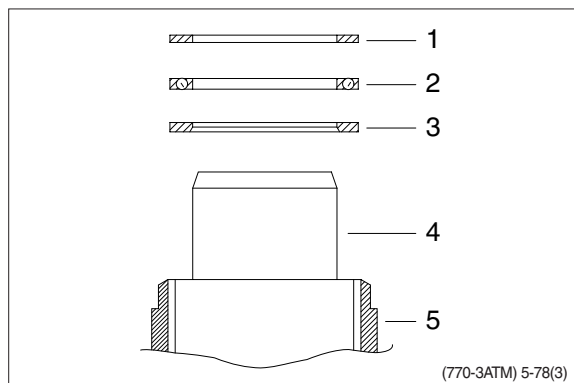

Installation instruction for O-ring

(10) Turn the steering unit until the bore is horizontal. Guide the outer part of the assembly tool into the bore for the spool / sleeve.

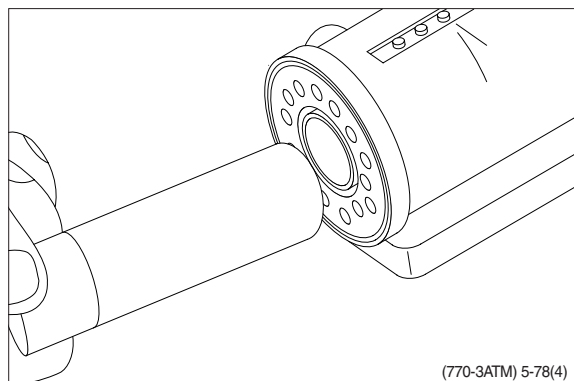

(11) Grease O-ring with hydraulic oil and place them on the tool.

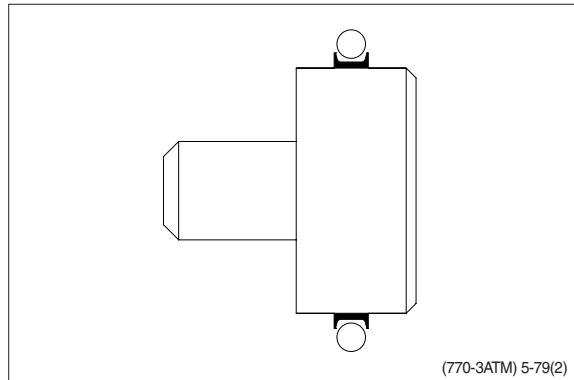
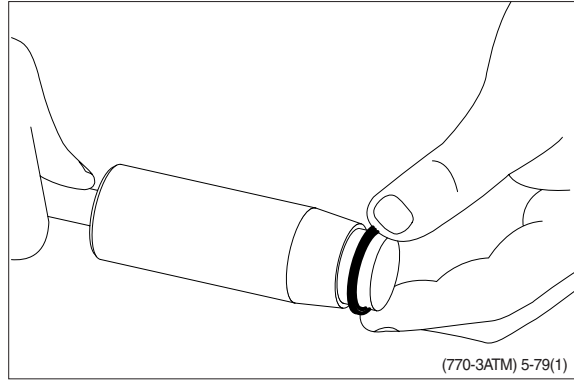

(12) Hold the outer part of the assembly tool in the bottom of the steering unit housing and guide the inner part of the tool right to the bottom.

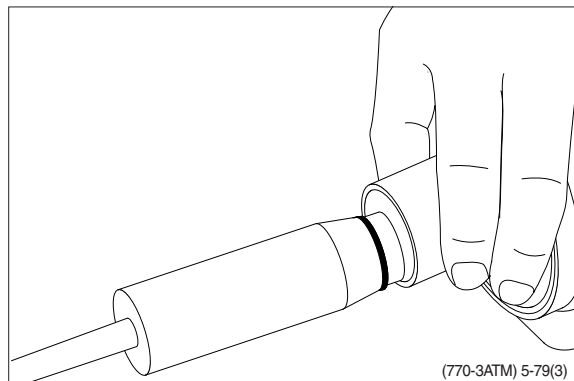

(13) Press and turn the O-ring into position in the housing.

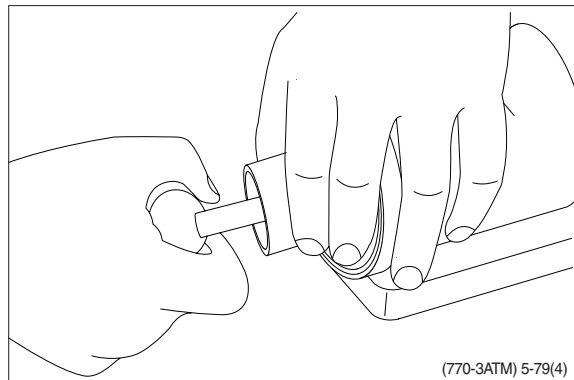

- (14) Draw the inner and outer parts of the assembly tool out of the steering unit bore, leaving the guide from the inner part in the bore.

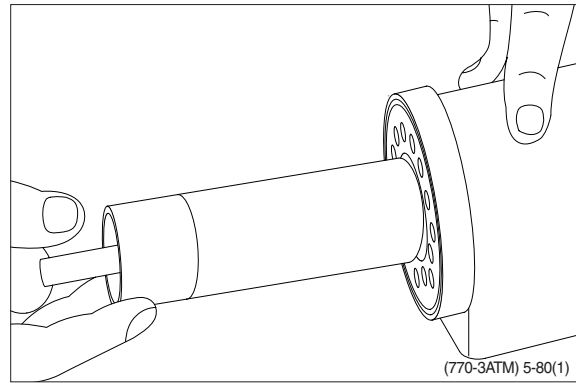

#### Installation instructions for lip seal

- (15) Lubricate the lip seal with hydraulic oil and place it on the assembly tool.

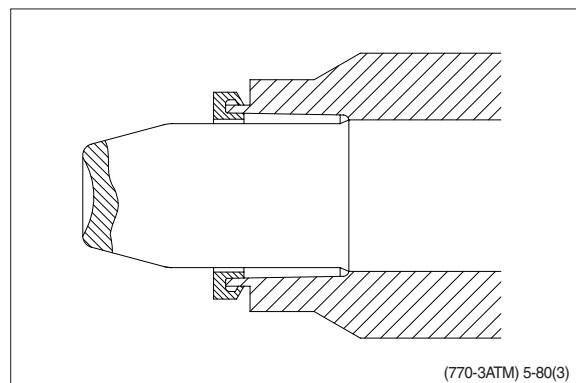
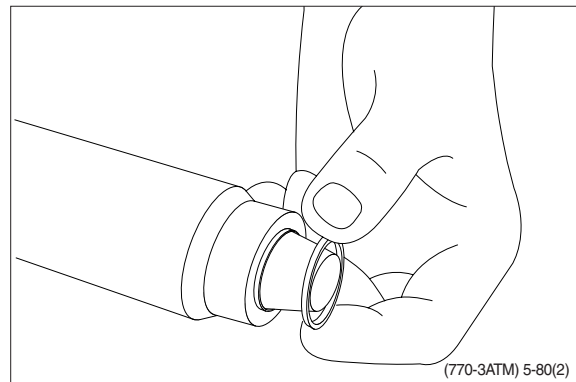

- (16) Guide the assembly tool right to the bottom.

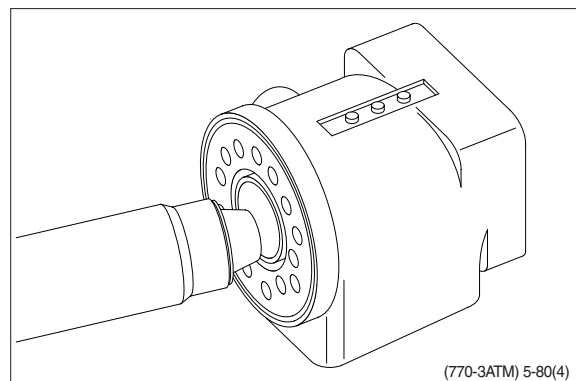

(17) Press and turn the lip seal into place in the housing.

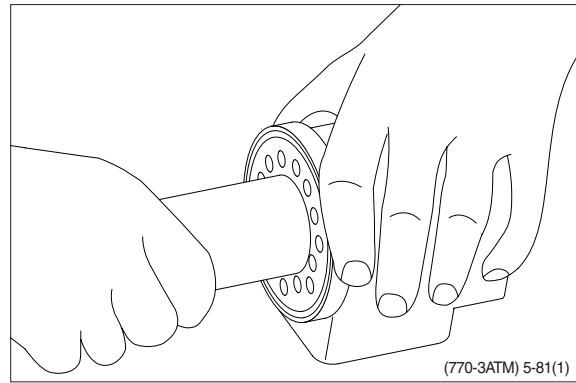

(18) With a light turning movement, guide the spool and sleeve into the bore.  
※ Fit the spool set holding the cross pin horizontal.

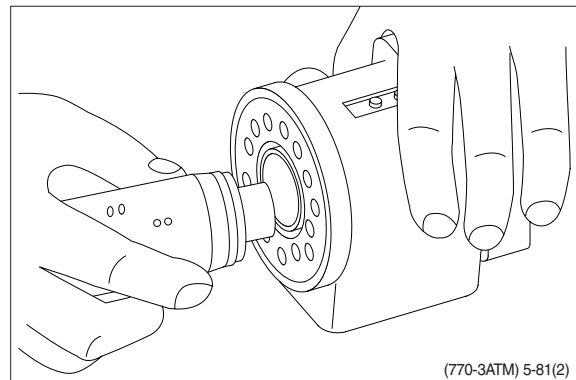

(19) The spool set will push out the assembly tool guide. The O-ring are now in position.

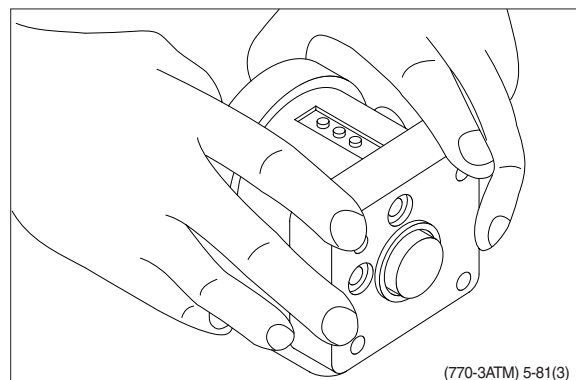

(20) Turn the steering unit until the bore is vertical again. Put the check valve ball into the hole indicated by the arrow.

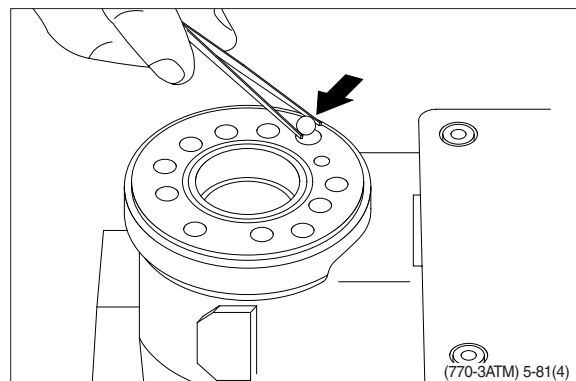

(21) Screw the threaded bush lightly into the check valve bore. The top of the bush must lie just below the surface of the housing.

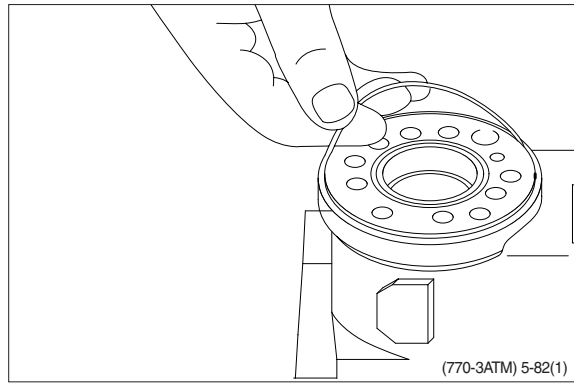

(22) Grease the O-ring with mineral oil approx. viscosity 500 cSt at 20° C .

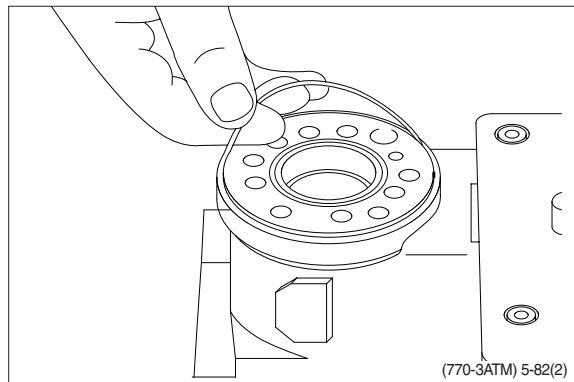

(23) Place the distributor plate so that the channel holes match the holes in the housing.

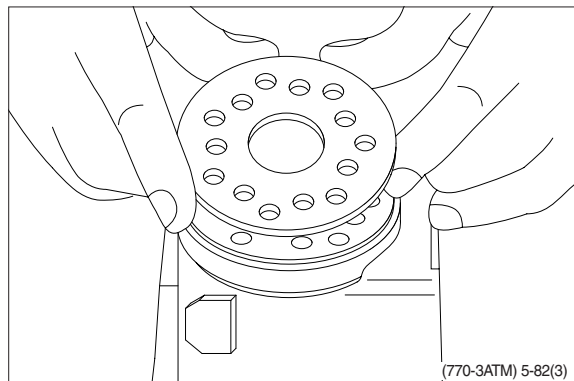

(24) Guide the cardan shaft down into the bore so that the slot is parallel with the connection flange.

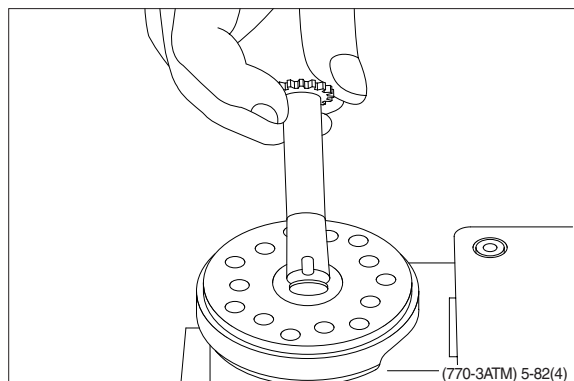

(25) Place the cardan shaft as shown - so that it is held in position by the mounting fork.

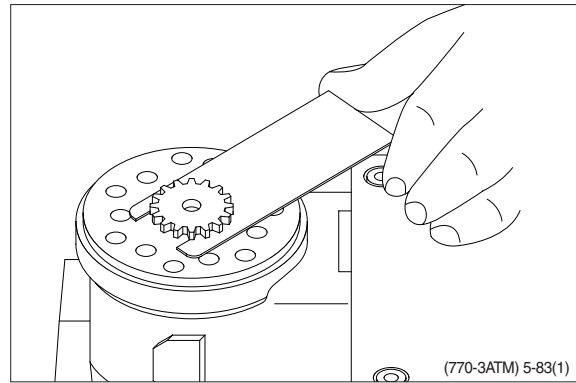

(26) Grease the two O-rings with mineral oil approx. viscosity 500 cSt at 20° C and place them in the two grooves in the gear rim. Fit the gearwheel and rim on the cardan shaft.

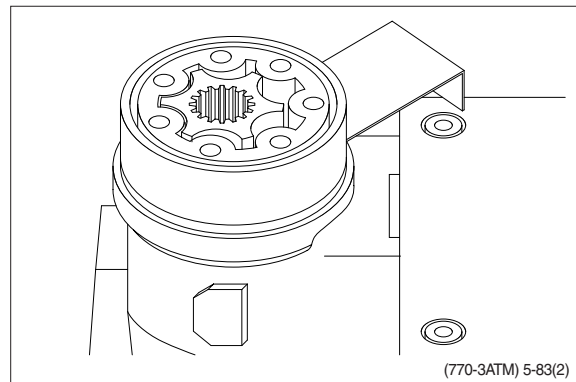

(27) Important

Fit the gearwheel(Rotor) and cardan shaft so that a tooth base in the rotor is positioned in relation to the shaft slot as shown.

Turn the gear rim so that the seven through holes match the holes in the housing.

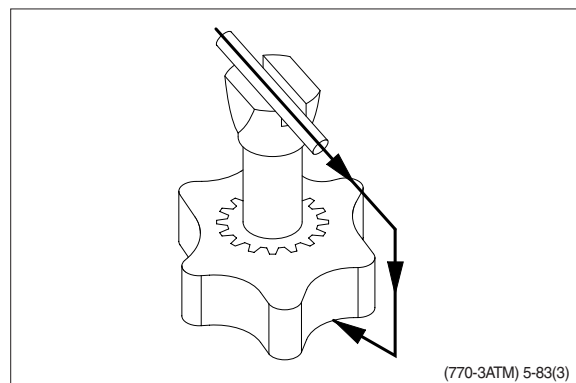

(28) Fit the spacer, if any.

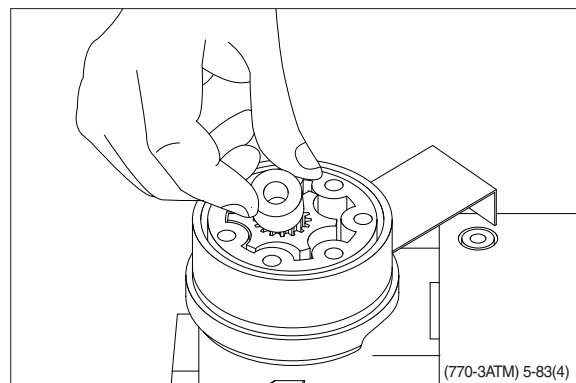

(29) Place the end cover in position.

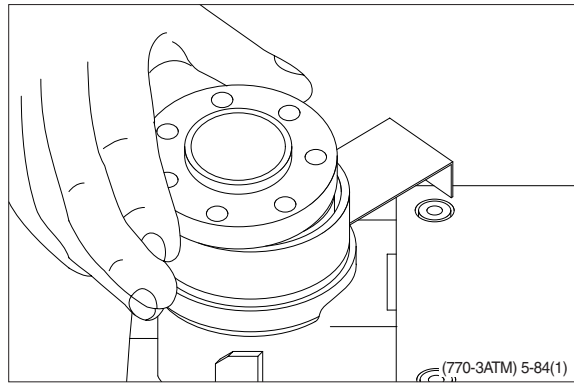

(30) Fit the special screw with washer and place it in the hole shown.

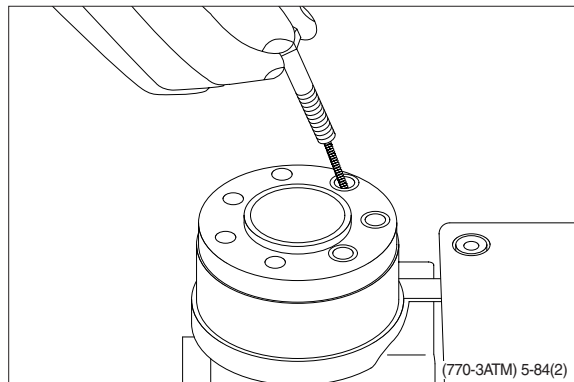

(31) Fit the six screws with washers and insert them. Cross-tighten all the screws and the rolled pin.

- Tightening torque :  $3.1 \pm 0.6 \text{ kgf} \cdot \text{m}$   
( $22.4 \pm 4.3 \text{ lbf} \cdot \text{ft}$ )

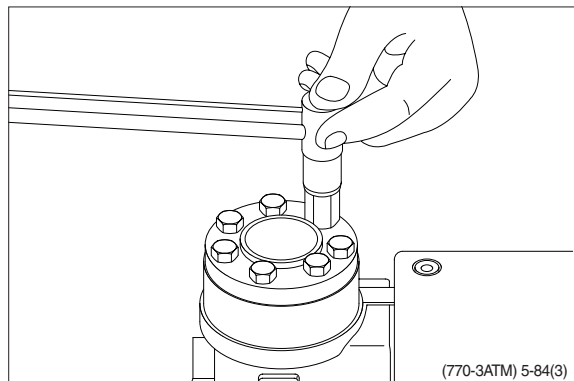

(32) Place the dust seal ring in the housing.

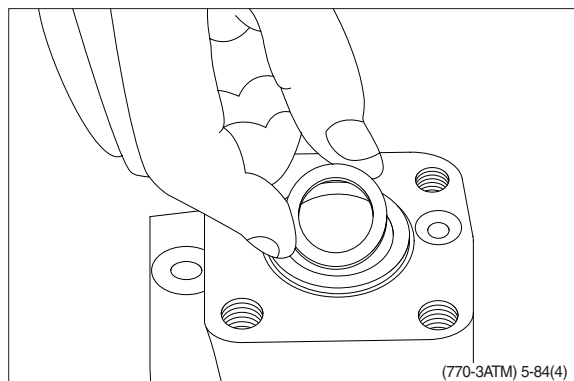

(33) Fit the dust seal ring in the housing.

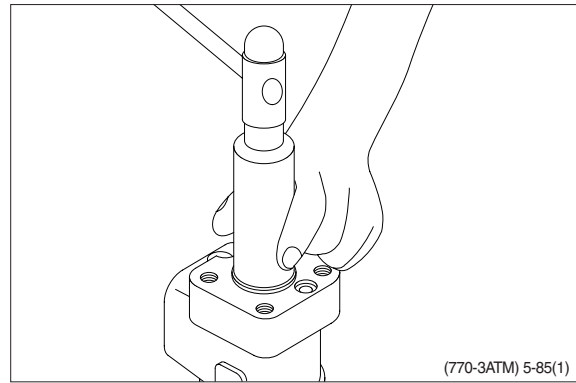

(34) Press the plastic plugs into the connection ports.

※ Do not use a hammer!

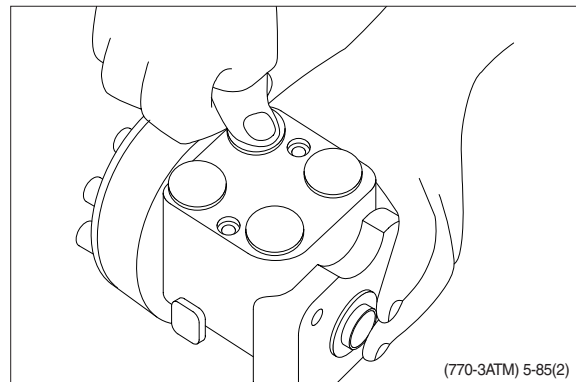

### 3. STEERING CYLINDER

#### 1) STRUCTURE

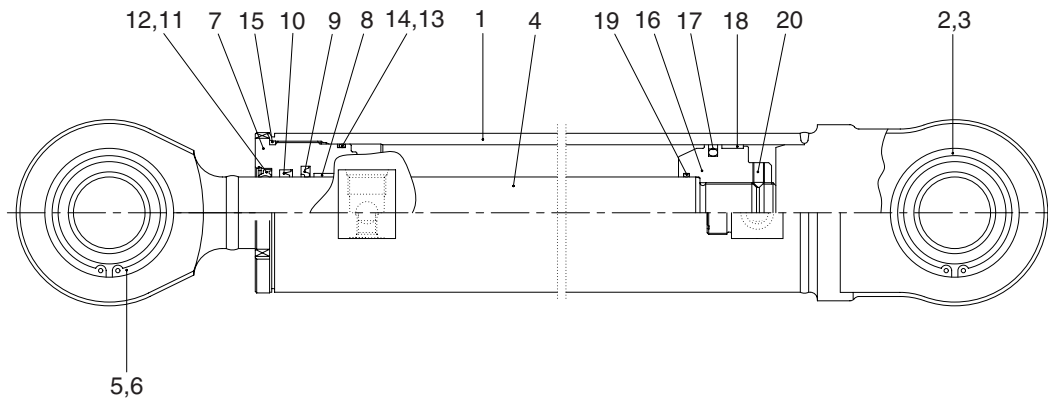

- |   |                   |    |                |    |             |
|---|-------------------|----|----------------|----|-------------|
| 1 | Tube assembly     | 8  | Rod bushing    | 15 | O-ring      |
| 2 | Spherical bearing | 9  | Buffer seal    | 16 | Piston      |
| 3 | Retaining ring    | 10 | U-packing      | 17 | Piston seal |
| 4 | Rod assy          | 11 | Dust wiper     | 18 | Wear ring   |
| 5 | Spherical bearing | 12 | Retaining ring | 19 | O-ring      |
| 6 | Retaining ring    | 13 | O-ring         | 20 | Set screw   |
| 7 | Gland             | 14 | Back up ring   |    |             |

77095SE17

## 2) TOOLS AND TIGHTENING TORQUE

### (1) Tools

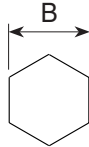
Tool name	B	Remark
L-wrench	6	
Spanner	13	
	65	
Wrench	For gland	
(-) Driver	Small and large sizes	
Torque wrench	Capable of tightening with the specified torques	

### (2) Tightening torque

Part name	Item	Size	Torque	
			kgf · m	lbf · ft
Gland	7	M100×2	50±5	362±36
Piston	16	M 42×2	50±5	362±36
Set screw	20	M 8×1.25	1.5	10.8

### 3) DISASSEMBLY

#### (1) Remove cylinder head and piston rod

- ① Hold the clevis section of the tube in a vise.
- ※ Use mouth pieces so as not to damage the machined surface of the cylinder tube. Do not make use of the outside piping as a locking means.

- ② Pull out piston rod (2) about 200 mm (7.8 in). Because the piston rod is rather heavy, finish extending it with air pressure after the oil draining operation.

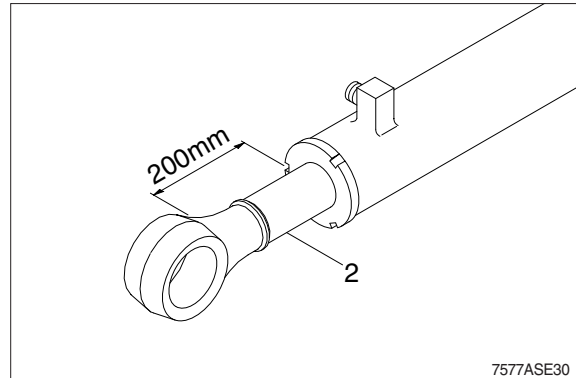

- ③ Loosen and remove the gland (7).
- ※ Cover the extracted piston rod (2) with rag to prevent it from being accidentally damaged during operation.

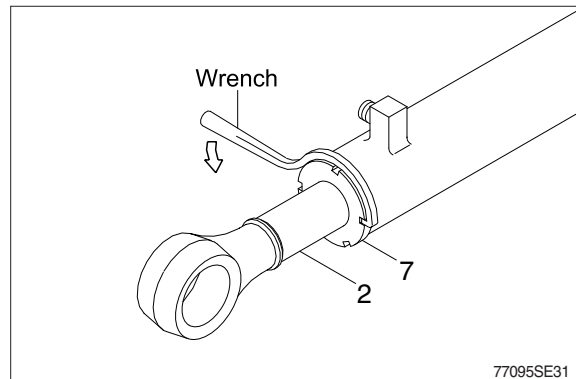

- ④ Draw out gland (7) and piston rod (2) assembly together from cylinder tube (1).
- ※ Since the piston rod assembly is heavy in this case, lift the tip of the piston rod (2) with a crane or some means and draw it out. However, when piston rod (2) has been drawn out to approximately two thirds of its length, lift it in its center to draw it completely.

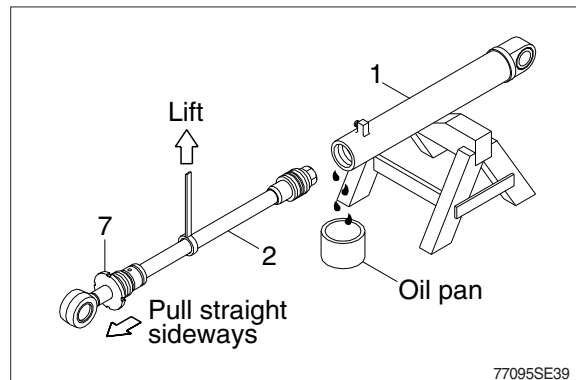

- ※ Note that the plated surface of piston rod (2) is to be lifted. For this reason, do not use a wire sling and others that may damage it, but use a strong cloth belt or a rope.

- ⑤ Place the removed piston rod assembly on a wooden V-block that is set level.
- ※ Cover a V-block with soft rag.

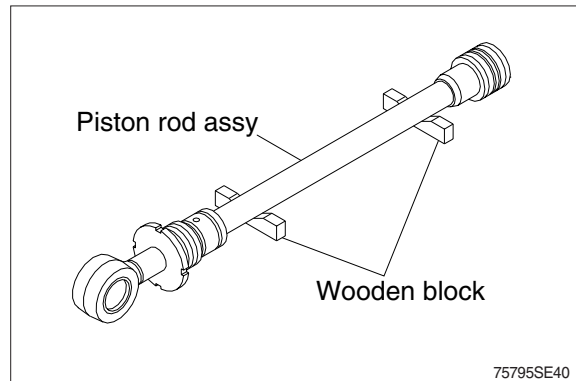

## (2) Remove piston and gland assembly

- ① Remove the set screw (20).
- ② Remove piston assembly (16) and O-ring (19).

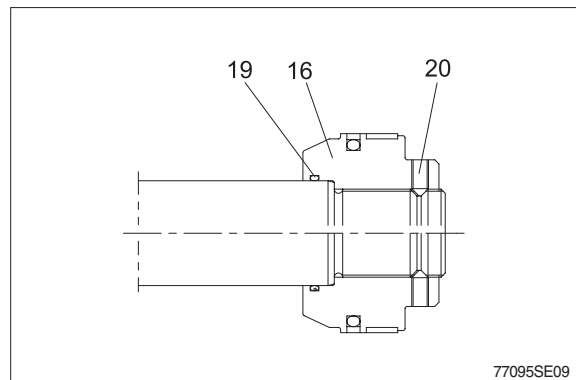

- ③ Remove the gland (7) assembly from piston rod (2).
  - ※ If it is too heavy to move, move it by striking the flanged part of gland (7) with a plastic hammer.
  - ※ Pull it straight with gland assembly lifted with a crane.
- Exercise care so as not to damage the lip of rod bushing (8) and packing (9, 10, 11, 12) by the threads of piston rod (2).

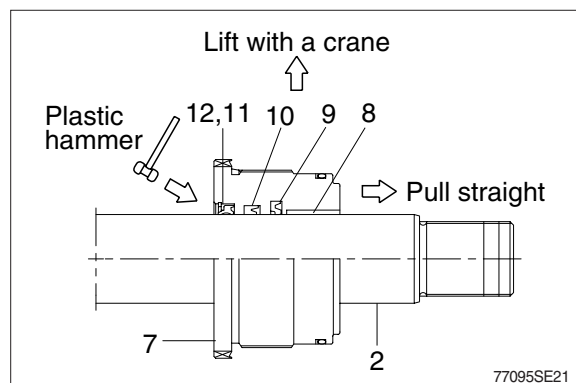

### (3) Disassemble the piston assembly

- ① Remove wear ring (18) and piston seal (17).  
Remove O-ring (19).
- ※ Exercise care in this operation not to damage the grooves.

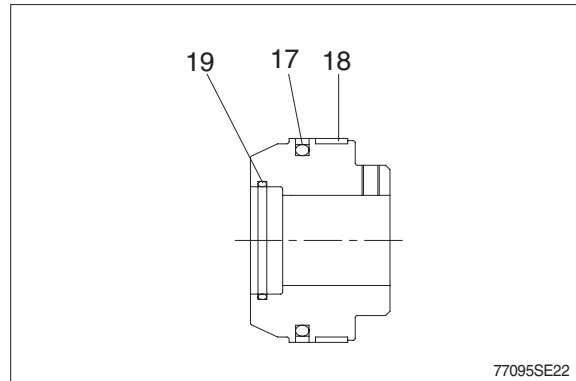

### (4) Disassemble gland assembly

- ① Remove back up ring (14), and O-ring (13).
  - ② Remove O-ring (15).
  - ③ Remove retaining ring (12) and dust wiper (11).
  - ④ Remove U-packing (10) and buffer seal (9).
- ※ Exercise care in this operation not to damage the grooves.
- ※ Do not remove seal and ring, if does not damaged.

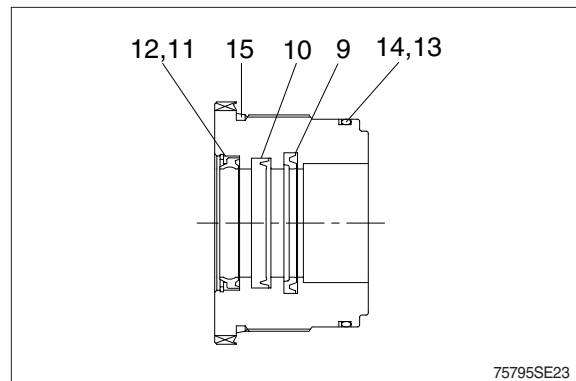

## 4) ASSEMBLY

### (1) Assemble gland assembly

- ※ Check for scratches or rough surfaces if found smooth with an oil stone.
- ① Coat the inner face of gland (7) with hydraulic oil.

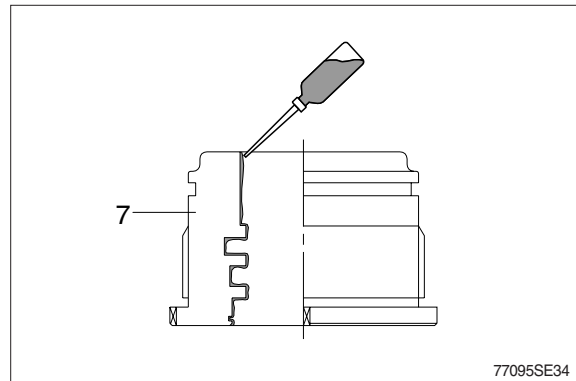

- ② Coat dust wiper (11) with grease and fit dust wiper (11) to the bottom of the hole of dust wiper.  
At this time, press a pad metal to the metal ring of dust seal.
- ③ Fit retaining ring (12) to the stop face.

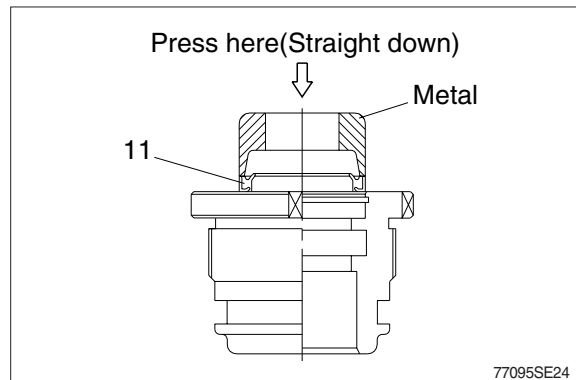

- ④ Fit U-packing (10) and buffer seal (9) to corresponding grooves, in that order.
- ※ Coat each packing with hydraulic oil before fitting it.
- ※ Insert the backup ring until outside of it is inserted into groove.

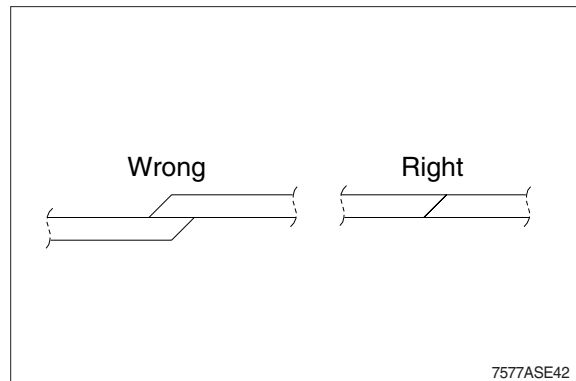

- ※ U-packing (10) has its own fitting direction.  
Therefore, confirm it before fitting them.
- ※ Fitting U-packing (10) up side down may damage its lip. Therefore check the correct direction that is shown in figure.

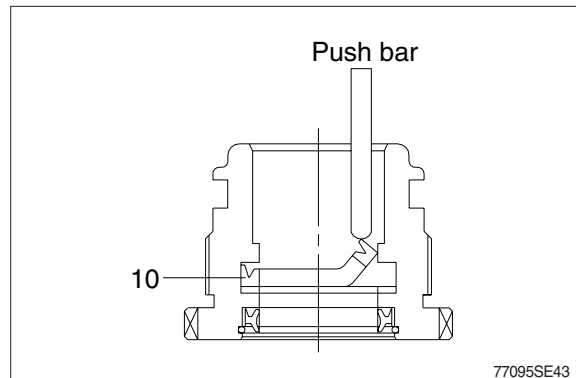

- ⑤ Fit back up ring (14) to gland (7).
- ※ Put the back up ring in the warm water of 30~50°C.
- ⑥ Fit O-ring (13, 15) to gland (7).
- ⑦ Fit bushing (8) to gland (7).

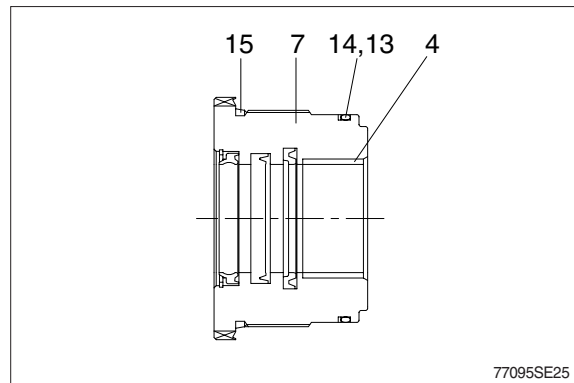

## (2) Assemble piston assembly

- ※ Check for scratches or rough surfaces.
- ① If found smooth with an oil stone.  
Coat the outer face of piston (16) with hydraulic oil.

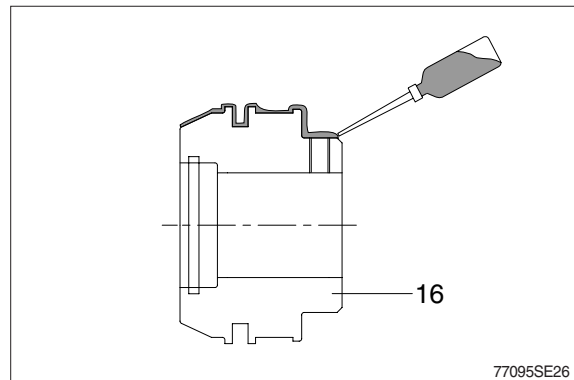

- ② Fit piston seal (17) to piston.
- ※ Put the piston seal in the warm water of 60~100°C for more than 5 minutes.
- ※ After assembling the piston seal, press its outer diameter to fit in.

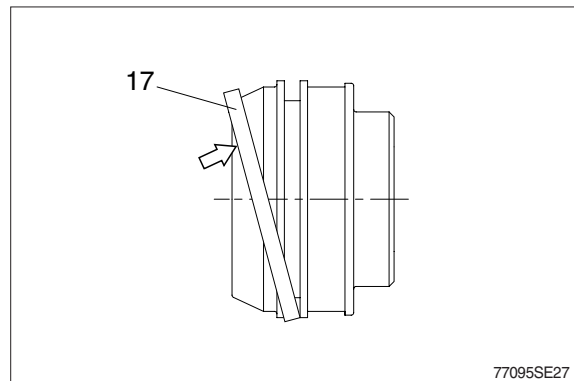

- ③ Fit wear ring (18) to piston (16).
- ④ Fit O-ring (19) to piston (16).

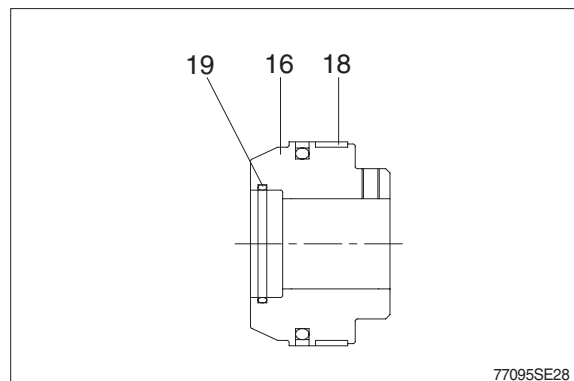

### (3) Install piston and gland assembly

- ① Fix the piston rod assembly to the work bench.
- ② Apply hydraulic oil to the outer surface of piston rod (2), the inner surface of piston and gland (7).
- ③ Insert gland assembly to piston rod (2).

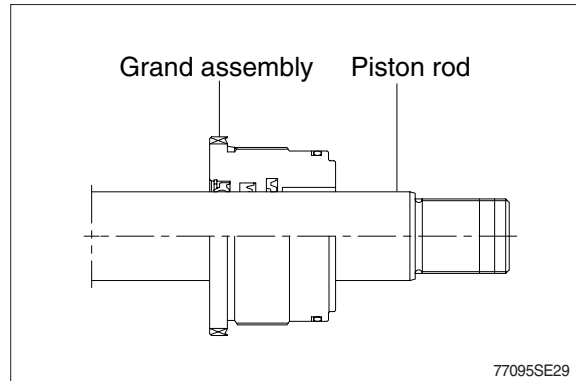

- ④ Fit piston assembly to piston rod.
  - Tightening torque :  $50 \pm 5$  kgf · m  
( $362 \pm 36$  lbf · ft)
- ⑤ Insert the set screw (20).
  - Tightening torque :  $1.5$  kgf · m  
( $10.8$  lbf · ft)

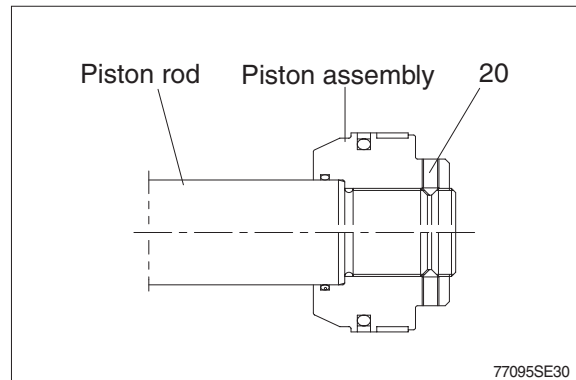

### (4) Overall assembly

- ① Place a V-block on a rigid work bench.  
Mount the cylinder tube assembly on it and fix the assembly by passing a bar through the clevis pin hole to lock the assembly.
- ② Insert the piston rod assembly in to the cylinder tube assembly, while lifting and moving the piston rod assembly with a crane.
  - ※ Be careful not to damage piston seal by thread of cylinder tube.
- ③ Fit gland to the tube.
  - Tightening torque :  $50 \pm 5$  kgf · m  
( $362 \pm 36$  lbf · ft)

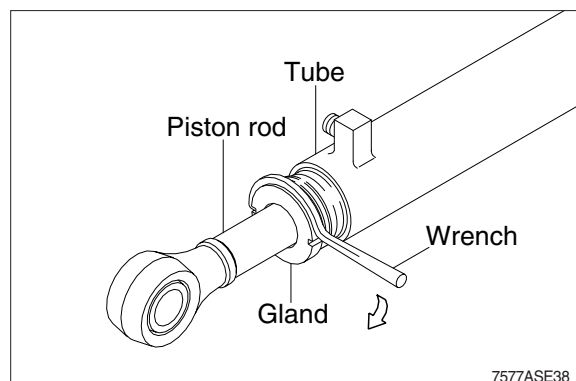
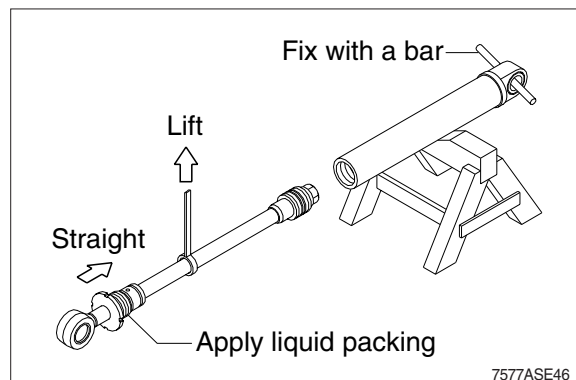

## 4. CENTER PIVOT PIN

### 1) CONSTRUCTION

Figure shows the construction of the center pivot pin assembly. This assembly serves to connect the front frame with the rear frame; two sets of assemblies are provided, one each for the upper and lower parts. The numbers in parentheses following the parts name denote the item numbers shown in the figure in the disassembly and assembly procedures.

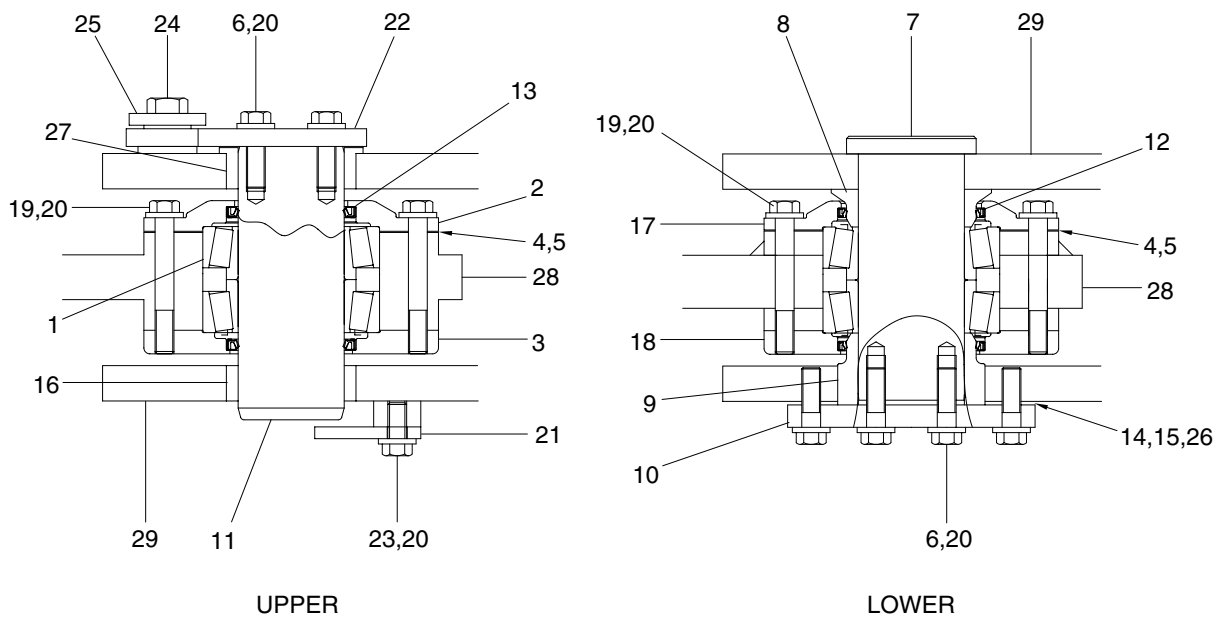

76095SE13

1	Bearing	11	Pin	21	Plate
2	Cover	12	Seal	22	Plate
3	Cover	13	Seal	23	Hexagon bolt
4	Shim (0.1 t)	14	Shim (0.1 t)	24	Hexagon bolt
5	Shim (0.5 t)	15	Shim (0.5 t)	25	Hardened washer
6	Hexagon bolt	16	Bushing	26	Shim (2.0 t)
7	Pin	17	Cover	27	Bushing
8	Collar	18	Cover	28	Front frame
9	Collar	19	Hexagon bolt	29	Rear frame
10	Plate	20	Hardened washer		

## 2) DISASSEMBLY

After supporting the front frame and the rear frame as horizontally as possible using wood blocks and jacks, disassemble as follows: In order to facilitate the disassembly/assembly of the center pivot pins, remove the drive shaft, hydraulic line and steering cylinder first.

- (1) Maintain the horizontal level of front frame (28) and rear frame (29), and then remove hexagon bolt (6, 23, 24), washer (20, 25) and plate (21,22).
- (2) Take out upper pin (11) to the downside using a metal punch.

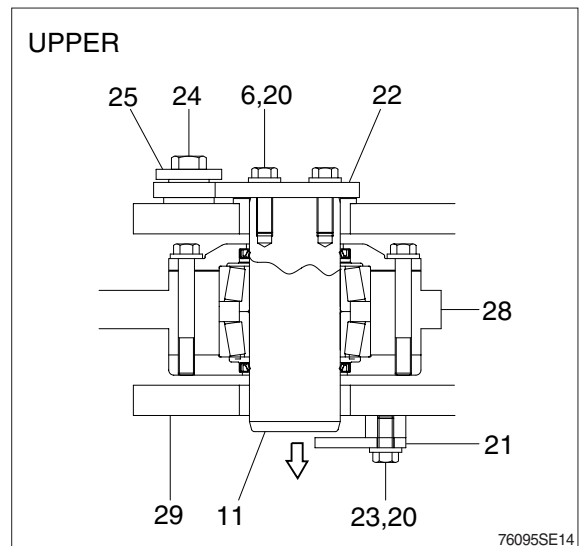

- (3) Maintain the front frame horizontal level, remove hexagon bolts (6) and then remove the plate (10) and shims (14, 15, 26).
- (4) Take out lower pin (7) to the upside using a metal punch carefully.
- (5) Jack up or lifting the front frame (28) slightly, the collar (9) protrudes over the rear frame. Remove the collar (9).
- (6) Lift the frame by passing the slinging wire rope at four positions of front frame, in order to separate it from the rear frame.
- (7) Support the front frame safely.

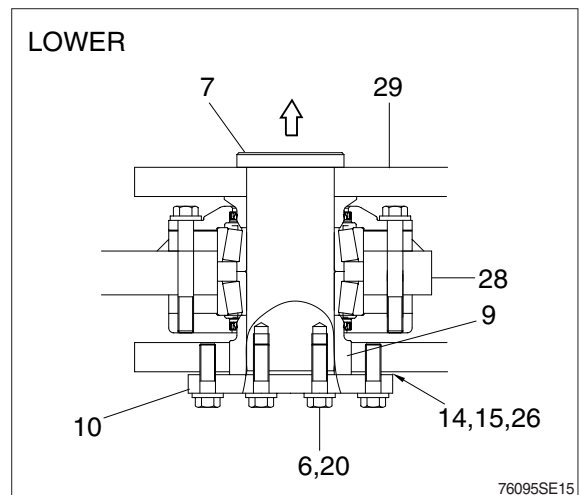

- (8) Remove bolt (19), washer (20) and then take out cover (2) and shims (4, 5).
- (9) Take out dust seal (13) from the cover (2).
- (10) Remove the bearing (1), and dust seal (13).

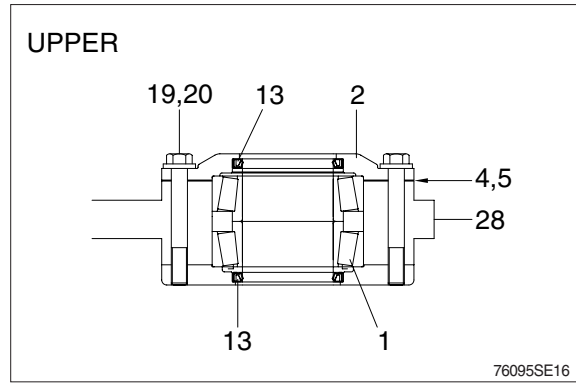

- (11) Remove bolt (19), washer (20) and then take out cover (17, 18) and shims (4, 5).
- (12) Take out the dust seal (12) from the cover (17, 18).
- (13) Remove the bearing (1) and collar (8).

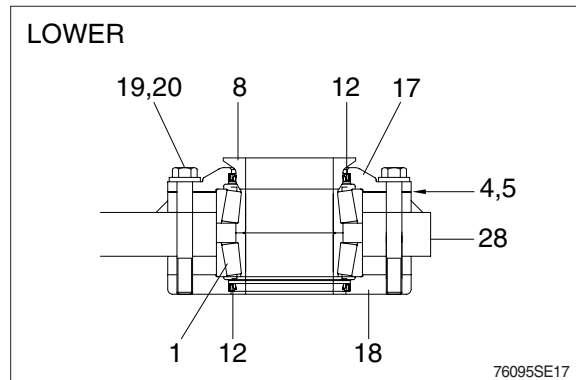

### 3) INSPECTION

- (1) Check the bearing sliding surface for excessive wear, scorching or scratches; replace if necessary.
- (2) Replace all dust seals (12,13) with new ones.
- (3) Grind any pins (7, 11) dented with an oilstone or replace any pins abrasive excessively.
- (4) Check inside cover (2, 3, 17, 18) and collar (8, 9) for dents or scratches; if any damage is found, correct with a grinder or replace.
- (5) The serviceable limit of pins and bushings is shown in the table below. Unit : mm

Item No.	Name	Std dimension	Serviceable limit			Remedy
			Outer dia	Inner dia	Clearance	
7, 11	Pin	90	89.5		0.8	Replace
1	Tapered roller bearing			90.5		
8, 9	Collar			90.5		
12, 13	Dust seal	When removed				Replace

#### 4) ASSEMBLY

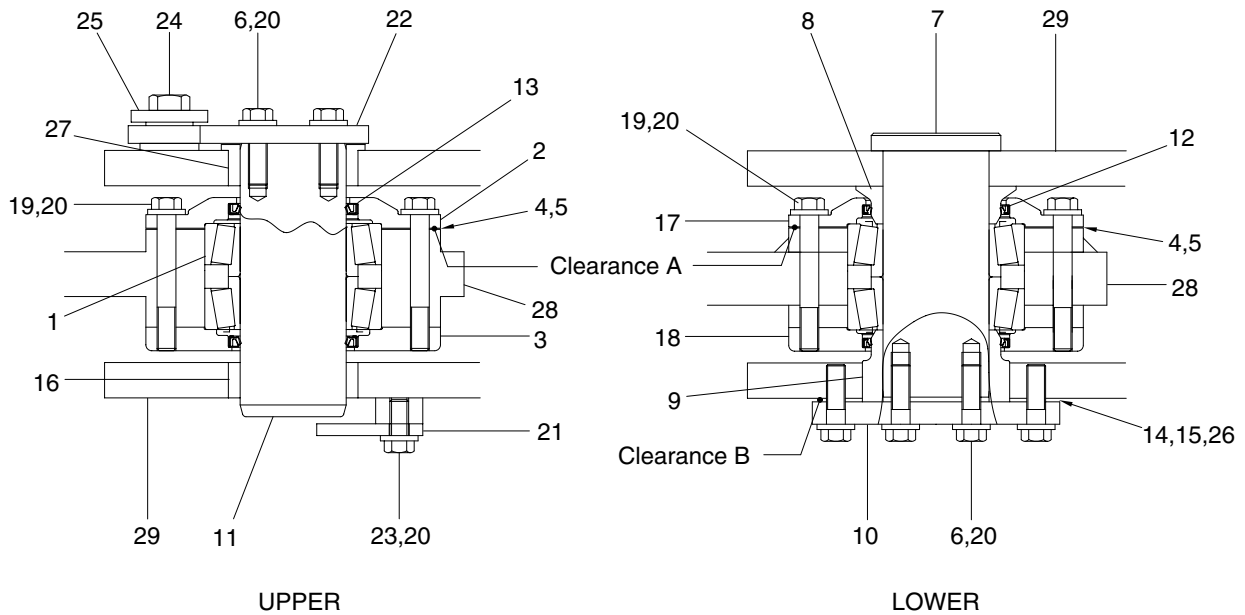

76095SE18

Assemble the center pivot group by reversing the order of disassembly while paying close attention to the following.

- (1) Put the dust seal (12,13) into cover (2, 3, 17, 18).
  - ※ Apply grease to the lip of the dust seal. Insert the dust seal so that the dust seal lip faces out and punch four places on the outer circumference of the seal to lock it.
- (2) Lower the temperature of the lower bearing cup to  $-75 \pm 5^{\circ}\text{C}$  ( $-103 \pm 9^{\circ}\text{F}$ ) and install it to front frame until it contacts the bottom of the frame.
- (3) Place the cover (3, 18).
- (4) Coat lightly with oil and install lower bearing in bore in front frame. Coat lightly with oil and install upper bearing in bore in upper front frame.
- (5) Place the cover (2, 17) and hold in place with bolt (19). At this time, adjust shims (4, 5) to press the shoulder of bearing (1) against retainer.
  - **Adjustment method of clearance A**
    - ① Install bearing (1) and cover (2, 17) without shim (4, 5)  
Install four of bolt (19) so that each bolt is separated by 90 degrees.
      - Tightening torque : 1.5~1.7 kgf · m (10.8~12.3 lbf · ft)
    - ② Adjust shims (4, 5) in order to control the clearance A.
      - Clearance A : Below 0.1 mm
      - Shim thickness : 0.1 mm, 0.5 mm

- (5) Apply grease to lower collar (8) and insert it to the lower of roller bearing.
- (6) After setting the bearing so that its upper surface is horizontal, tighten the all the bolt (19).  
After tightening, confirm that tapered roller bearing moves lightly ; if does not move smoothly, add shims (4, 5).
- Tightening Torque : 25.4~34.2 kgf · m (184~247 lbf · ft)
  - Apply loctite #243.
- (7) Move the front frame and join it to the rear frame so that match the pin hole at the center.
- (8) Apply grease to pin (11), bushing (27) and insert it into tapered roller bearing (1).
- (9) Apply grease to lower collar (9) and insert it to the lower of roller bearing through rear frame (29).
- (10) Apply grease to pin (7) and insert it into tapered roller bearing (1).
- (11) Before tightening bolt (6), adjust shims (14, 15) in order to control the clearance between the plate (21) and rear frame (29).
- **Adjustment method of clearance B**
  - ① Install pin (7) and plate (21) without shim (14,15, 27).  
Install four of bolt (6) so that each bolt is separated by 90 degrees.
    - Tighting torque : 1.5~1.7 kgf · m (10.8~12.3 lbf · ft)
  - ② Adjust shims in order to control the clearance B.
    - Clearance B : 0.1~0.2 mm
    - Shim thickness : 0.1 mm, 0.5 mm, 2.0 mm
- (12) Tighten the all the bolts (6).
- Tightening Torque : 25.4~34.2 kgf · m (184~247 lbf · ft)
  - Apply loctite #243.

## 5) TROUBLESHOOTING

Trouble	Probable cause	Remedy
Shock is felt when steering	Capscrew for fixing steering valve is loose	Retighten
	Faulty center pivot pin mounting bolts	Retighten
	Center pivot pins have worn out	Readjust or replace
	Faulty hydraulic system	See hydraulic system
Shock is felt when moving backward or forward	Fault fixing of connecting capscrews	Retighten
	Center pins have worn out	Readjust or replace
	Bearings of support unit have worn out	Retighten
	Drive shaft damaged	See drive system
	Faulty transmission	See transmission system