

GROUP 4 DISASSEMBLY AND ASSEMBLY

1. CONTROL VALVE

1) DISASSEMBLY

(1) Loosen the cap screws and take off the gear shift housing.

※ Special tool
Socket spanner TX-27 5873 042 002

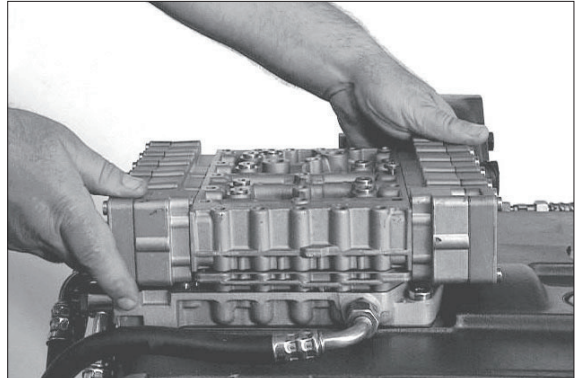

Figure 1001

(2) Separate the hose lines from the duct plate. Loosen the cap screws as well as the gasket from the transmission housing.

※ Special tool
Socket spanner TX-40 5873 042 004

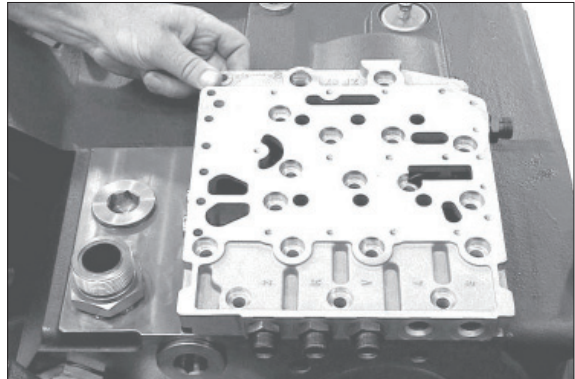

Figure 1002

(3) Mark the installation position of the wiring harness to the valve block.

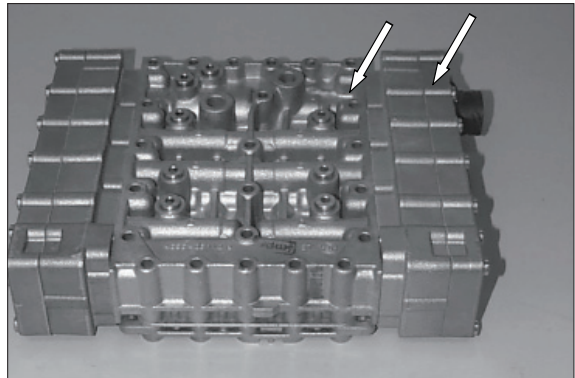

Figure 1003

(4) Loosen the cap screws.
Separate duct plate and intermediate plate from the valve block.

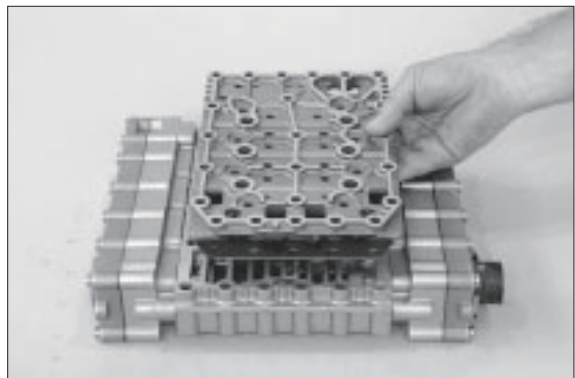

Figure 1004

(5) Remove the retaining clamp

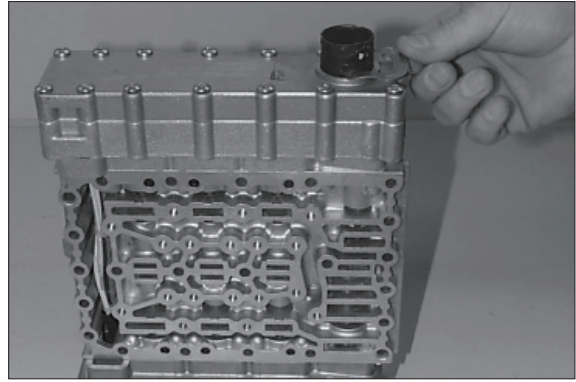

Figure 1005

(6) Loosen the cap screws and take off the cover.
Remove the opposite cover.

※ Special tool
Socket spanner TX-27 5873 042 002

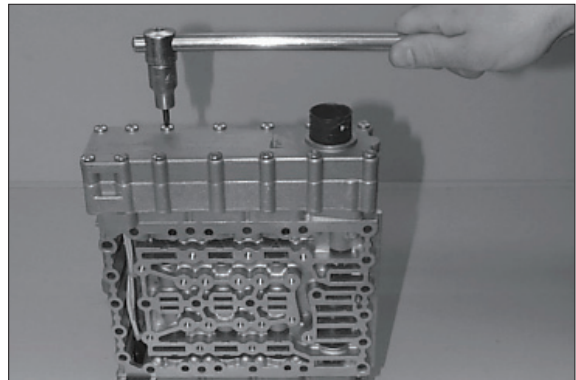

Figure 1006

(7) Remove the wiring harness.

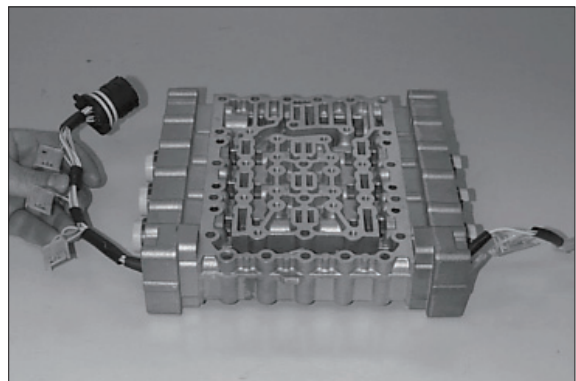

Figure 1007

(8) Loosen the cap screws, remove the fixing plates and the pressure controllers.

※ Special tool
Socket spanner TX-27 5873 042 002

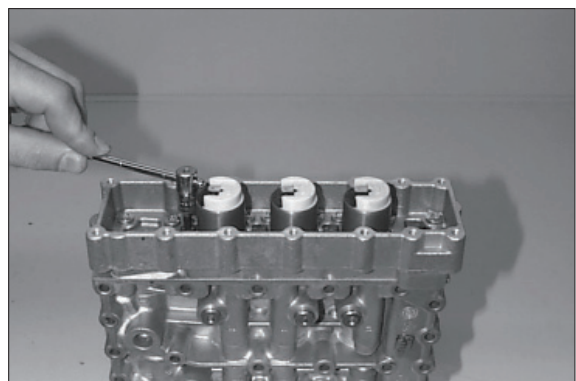

Figure 1008

(9) Loosen two cap screws and fasten the housing preliminarily by means of adjusting screws (housing is preloaded). Then loosen the remaining cap screws.

- ※ Special tool
- Adjusting screws 5870 204 036

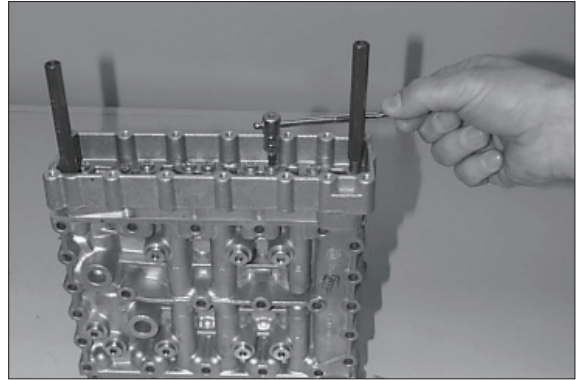

Figure 1009

(10) Separate the housing from the valve housing by equally loosening the adjusting screws.

- ※ Special tool
- Adjusting screws 5870 204 036

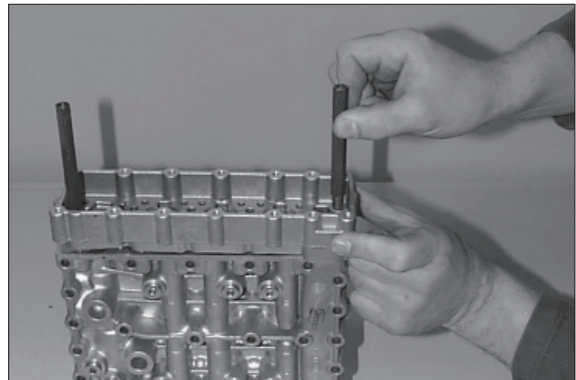

Figure 1010

(11) Remove the single components.

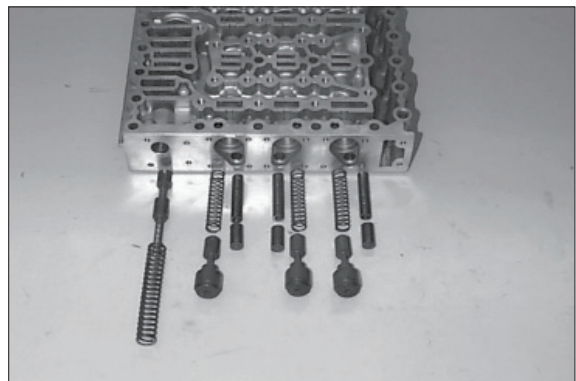

Figure 1011

(12) Remove the opposite pressure controllers, the housing as well as single components analogously.

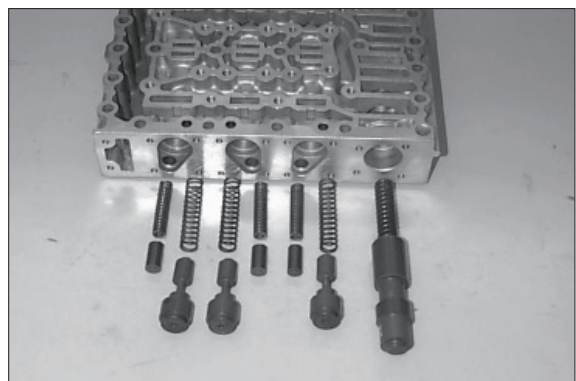

Figure 1012

2) ASSEMBLY

- ※ All single components are to be checked for damage and replaced, if required.
Prior to installation check the mobile parts in the housing for functionality.
Pistons can be replaced individually.
Oil the single components prior to installation.
Place the orifices, with the concave side showing upwards, until contact.
- ※ Installation position, see arrows.

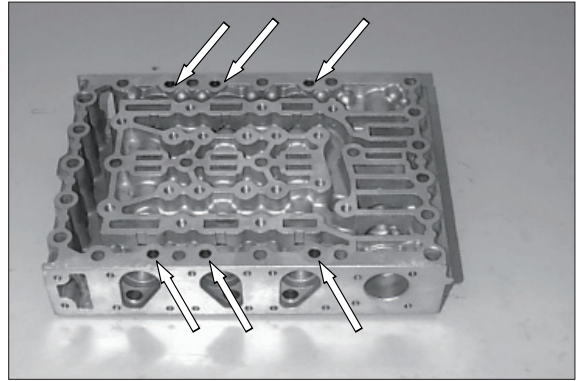

Figure 1013

- (1) Opposite figure shows the following single components.
- 1 Vibration damper
(3EA, piston & comp spring)
 - 2 Follow-on slide
(3EA, piston & comp spring)
 - 3 Pressure reducing valve
(1EA, piston & comp spring)

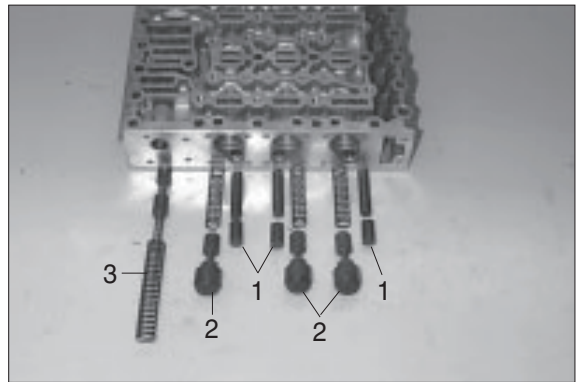

Figure 1014

- (2) Install the single components according to figure 1014.
- ※ Preload the compression springs of the follow-on slides and fasten the pistons preliminarily by means of cylindrical pins \varnothing 5.0 mm (assembly aid), see arrows/ figure 1015.

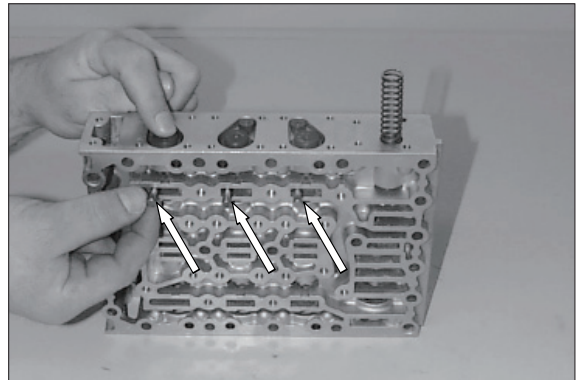

Figure 1015

- (3) Install two adjusting screws.
Assemble gasket (arrow) and housing cover (figure 1016).
Then place the housing cover by means of adjusting screws equally until contact (figure 1017).
- ※ Special tool
Adjusting screws 5870 204 036

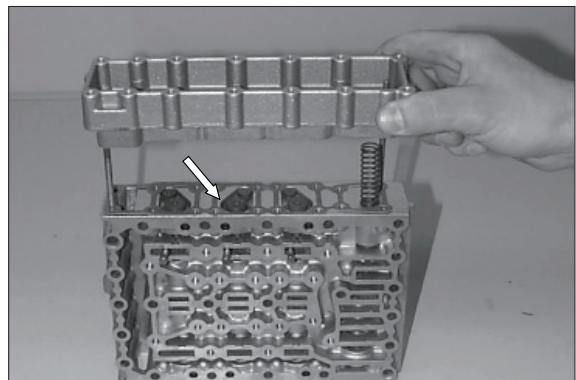

Figure 1016

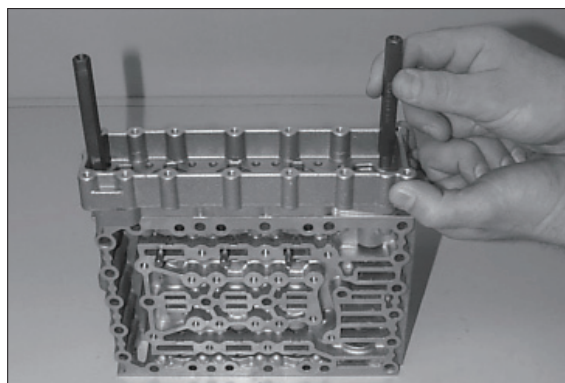

Figure 1017

- (4) Preload the pistons and remove the adjusting screws (assembly aid) again.

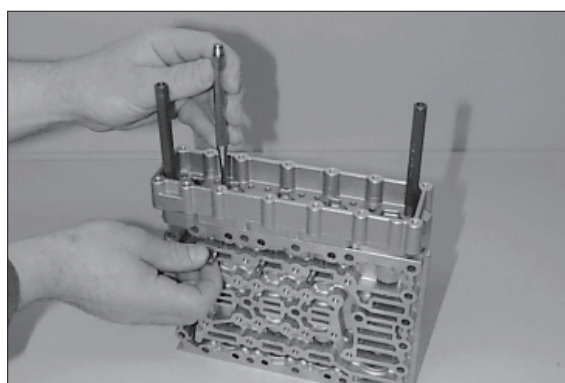

Figure 1018

- (5) Fasten the housing cover with cap screws.
 · Torque limit : 0.76 kgf · m (5.53 lbf · ft)

※ Special tool

Socket spanner TX-27 5873 042 002

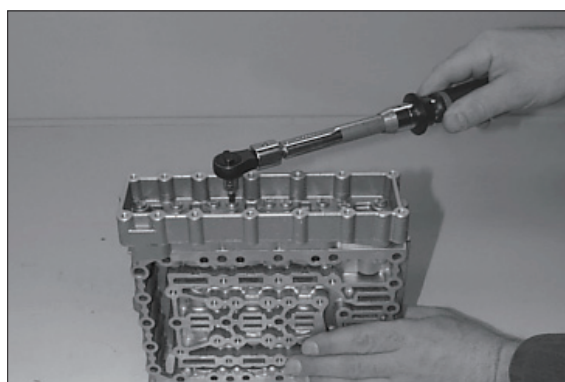

Figure 1019

- (6) Assemble the pressure controllers and fasten them by means of fixing plates and cap screws.

※ Install the fixing plate with the neck showing downwards.

Observe radial installation position of the pressure controllers, see Figure.

· Torque limit : 0.56 kgf · m (4.06 lbf · ft)

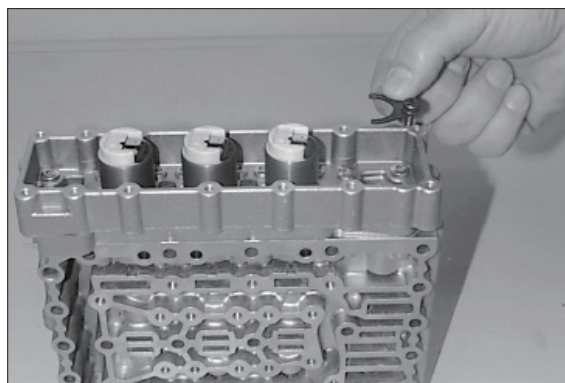

Figure 1020

Preassemble the opposite side :

(7) The opposite figure shows the following single components :

- 1 Main pressure valve
(1EA, piston & comp spring)
- 2 Follow-on slide
(3EA, piston & comp spring)
- 3 Vibration damper
(3EA, piston & comp spring)

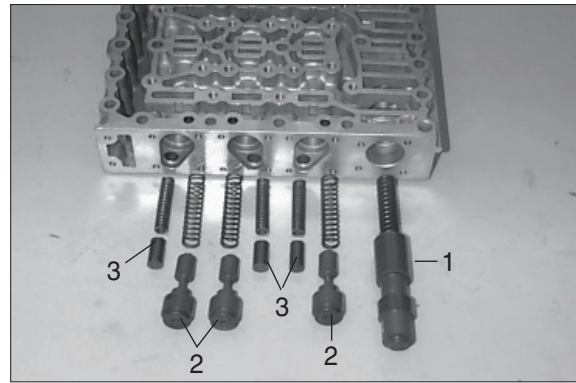

Figure1021

(8) Install the single components according to figure 1021.

Preload the compression springs of the follow-on slides and fasten the piston preliminarily by means of cylindrical pins \varnothing 5 mm (assembly aid), see arrows.

Install two adjusting screws.

Assemble the gasket (arrow 1) and the housing cover and place them equally until contact by means of adjusting screws.

Then fasten the housing cover with cap screws.

- Torque limit : 0.76 kgf · m (5.53 lbf · ft)

Remove the cylindrical pins (assembly aid) again.

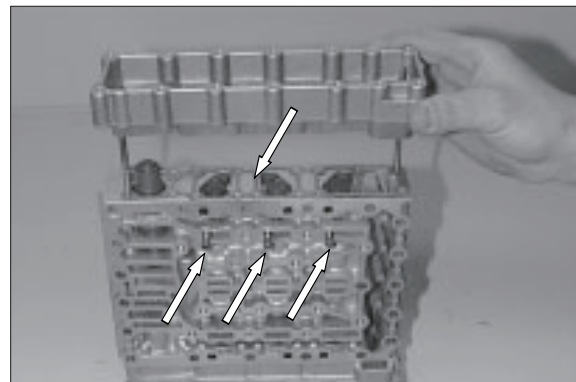

Figure1022

※ Special tool

Adjusting screws 5870 204 036

(9) Assemble the pressure controllers and fasten them by means of fixing plates and cap screws.

※ Install the fixing plates with the neck showing downwards.

Observe radial installation position of the pressure controllers, see Figure.

- Torque limit : 0.56 kgf · m (4.06 lbf · ft)

※ Special tool

Socket spanner TX-27 5873 042 002

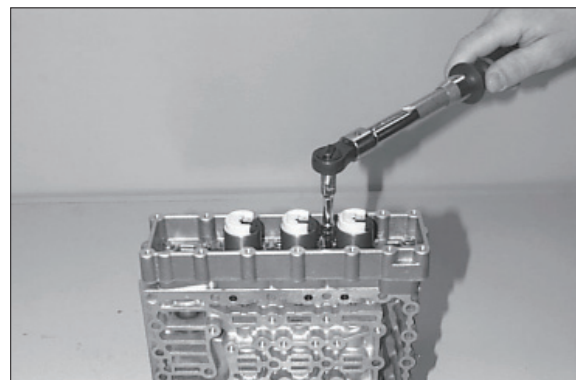

Figure1023

(10) Assemble the wiring harness and connect the pressure controllers (6EA).

※ Pay attention to the installation position of the wiring harness, also see markings (figure 1003).

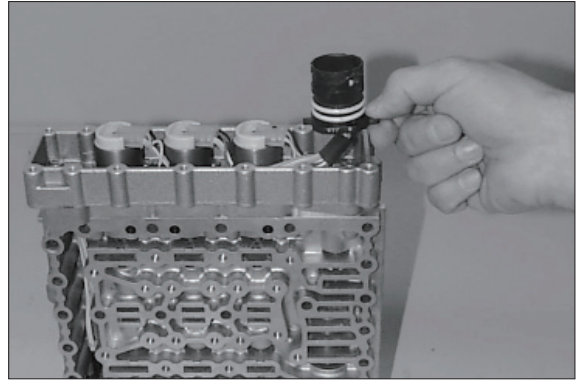

Figure1024

(11) Put on the flat gasket (arrow).

Assemble the plug socket with the slot showing to the lug of the cover until contact.

Fasten the cover by means of cap screws.

· Torque limit : 0.76 kgf · m (5.53 lbf · ft)

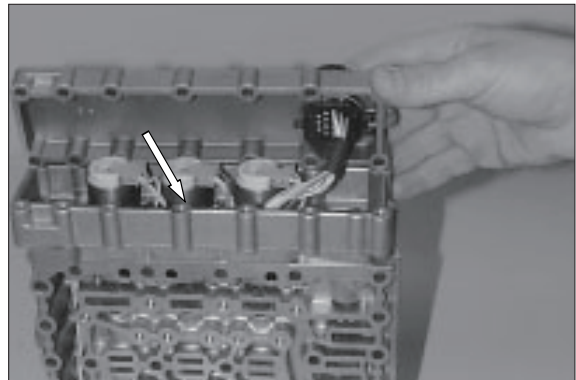

Figure1025

(12) Fasten the plug socket a retaining clamp.

Install the opposite cover.

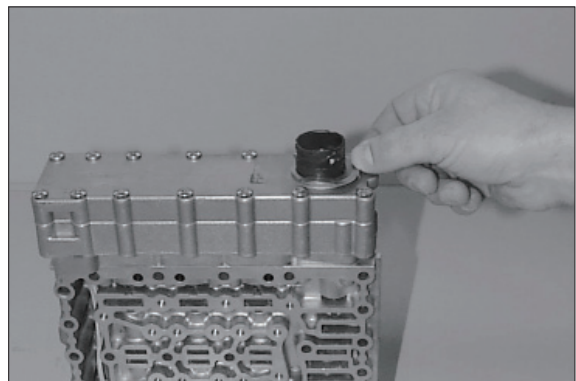

Figure 1026

(13) Screens (6EA) are to be flush mounted into the bores of the intermediate sheet, see arrows.

※ Observe the installation position-the screens are showing upwards (to the duct plate)

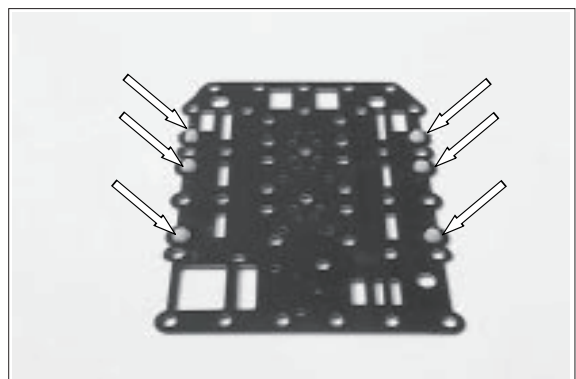

Figure1027

- (14) Install two adjusting screws.
Place the intermediate sheet with the screens showing upwards.

※ Special tool
Adjusting screws 5870 204 063

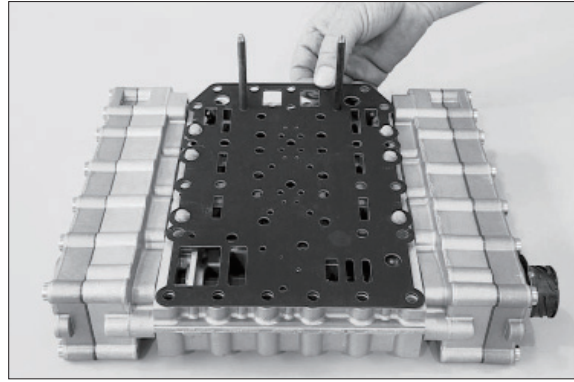

Figure1028

- (15) Put on the duct plate and fasten it equally by means of cap screws.
· Torque limit : 0.97 kgf · m (7.01 lbf · ft)

※ Special tool
Socket spanner TX-27 5873 042 002

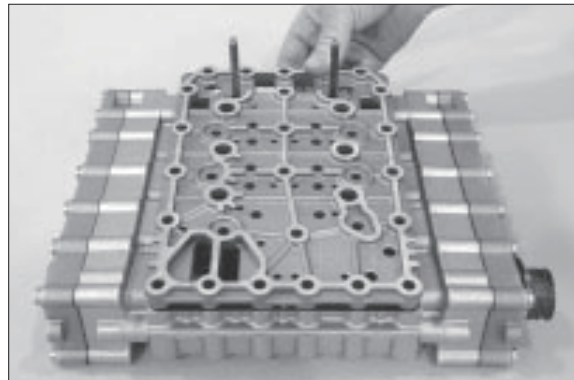

Figure1029

- (16) Provide the screw plugs (8EA) with new O-rings and install them.
· Torque limit : 0.61 kgf · m (4.43 lbf · ft)

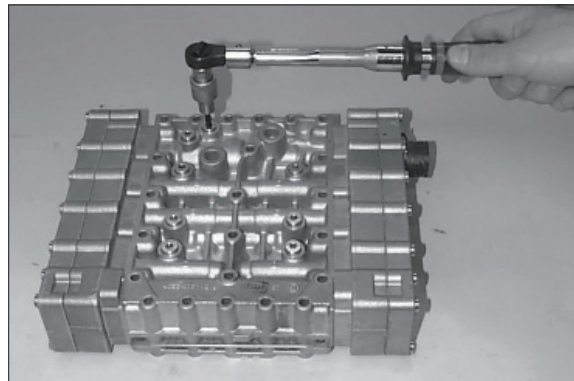

Figure1030

Preassemble the duct plate (figure 1031)

- (17) Install connection pipes 1~4.
Install screw plugs 5 and 6.
· Torque limit
Plug (M10 × 1) : 0.61 kgf · m (4.43 lbf · ft)
Plug (M14 × 1.5) : 4.08 kgf · m (29.5 lbf · ft)

※ Always install new O-rings.

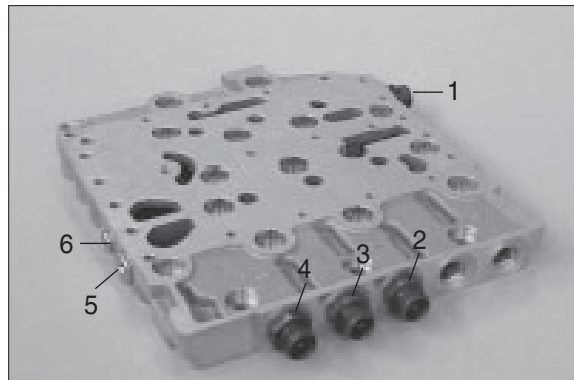

Figure1031

Installation of the Hydraulic Control Unit (HCU-94)(figure1032~1036) :

(18) Provide the screw plug with a new O-ring and install it.

· Torque limit

M26 × 1.5 : 8.16 kgf · m (59.0 lbf · ft)

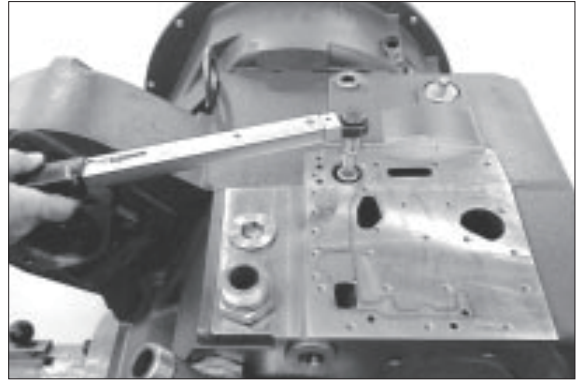

Figure 1032

(19) Install two adjusting screws.

Put on the gasket (arrow).

※ Special tool

Adjusting screws M8 5870 204 011

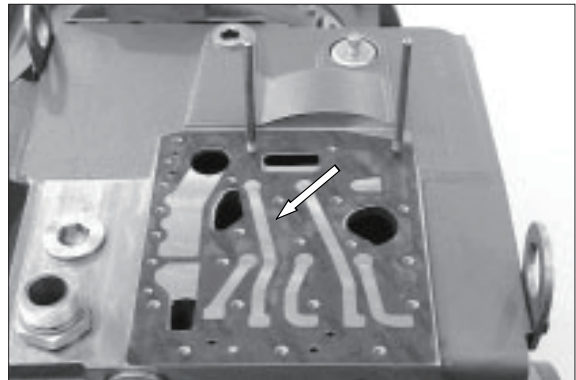

Figure 1033

(20) Put on the duct plate and fasten it equally by means of cap screws.

· Torque limit

M8/10.9 : 2.35 kgf · m (16.7 lbf · ft)

※ Special tool

Socket spanner TX-40 5873 042 004

Torque spanner Slipper 5870 203 043

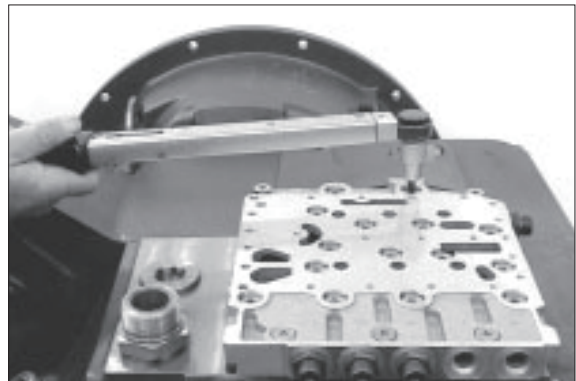

Figure 1034

(21) Install 2 adjusting screws (M6).

Put on the gasket (arrow).

※ Special tool

Adjusting screws M6 5870 204 063

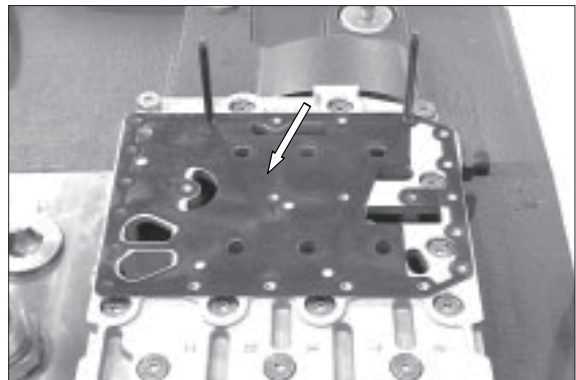

Figure 1035

(22) Fasten the complete valve block equally by means of cap screws (6pcs. M6 × 100 & 17pcs. M6 × 76 mm).

▲ Observe position of the cap screws (M6 × 100), see arrow.

· Torque limit : 1.22 kgf · m (8.85 lbf · ft)

※ Special tool

Socket spanner TX-27 5873 042 002

Torque spanner slipper 5870 203 043

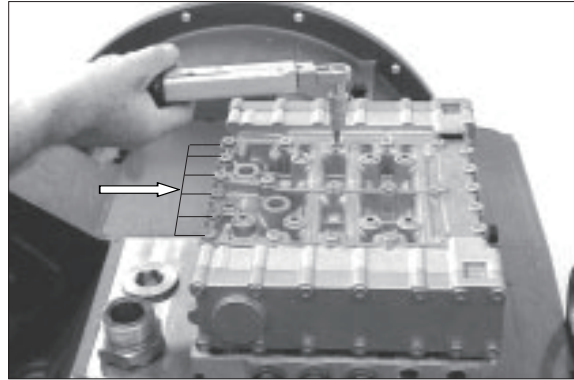

Figure 1036

Following to this all pressure lines are to be installed.

※ Installation of the lines differs depending on the version.

Observe the parts list of parts manual.

2. TRANSMISSION

1) DISASSEMBLY

(1) Fasten the complete transmission to the assembly truck.

※ Special tool

Assembly truck 5870 350 000

Holding fixture 5870 350 071

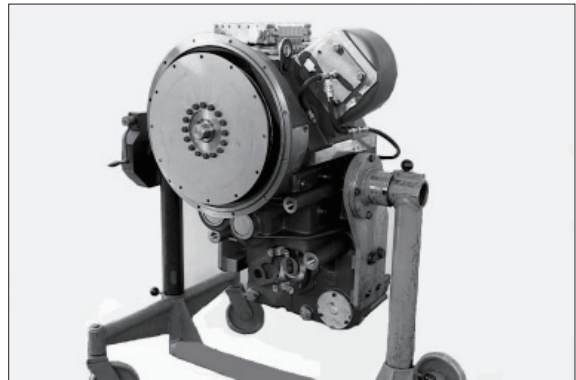

Figure 1

(2) Remove the plug (arrow) and drain the oil. Then remove the oil cylinder.

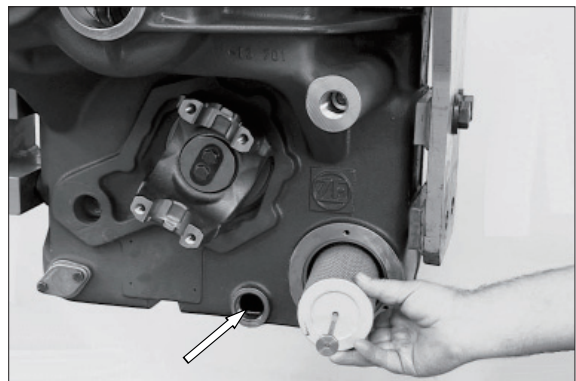

Figure 2

(3) Remove all oil pipes, the complete gear shift system and the duct plate.

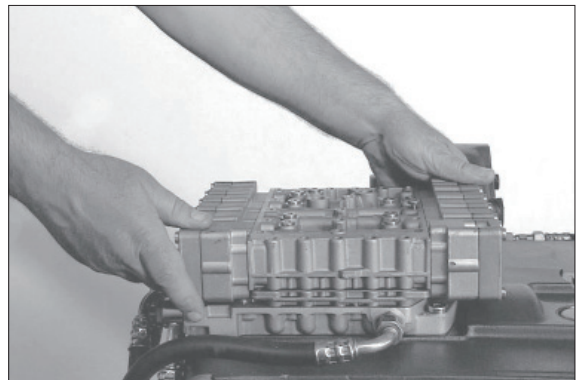

Figure 3

Converter drive

(1) By means of the lifting tackle separate the torque converter from the transmission.

※ Special tool

Eybolts assortment 5870 204 002

Lifting chain 5870 281 047

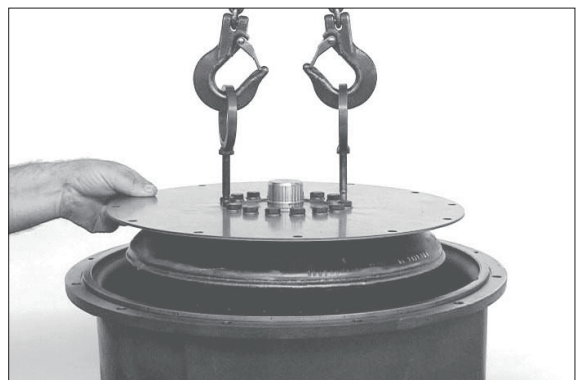

Figure 4

(2) Loosen the bolt connection and by means of the forcing screws (3EA) separate the cover from the converter bell.

※ Special tool
Forcing screws 5870 204 005

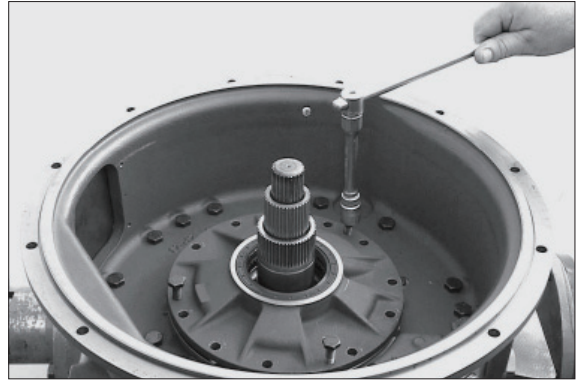

Figure 5

(3) By means of the extractor pull the oil supply flange out of the converter bell.

※ Special tool
Extractor 5870 000 089



Figure 6

(4) Remove the converter safety valve (arrow 1), if required.

※ Converter safety valve is fixed by means of slotted pin (arrow 2).



Figure 7

(5) Loosen the bolt connection (M8 and M12) and by means of lifting tackle and pry bar set separate the converter bell from the transmission housing.

※ Special tool
Eyebolts assortment 5870 204 002
Pry bar set 5870 345 036
Lifting chain 5870 281 047



Figure 8

(6) Remove the rectangular ring (arrow).



Figure 9

(7) Press the input shaft out of the spur gear bearing. Remove the released bearing inner ring and the spur gear.

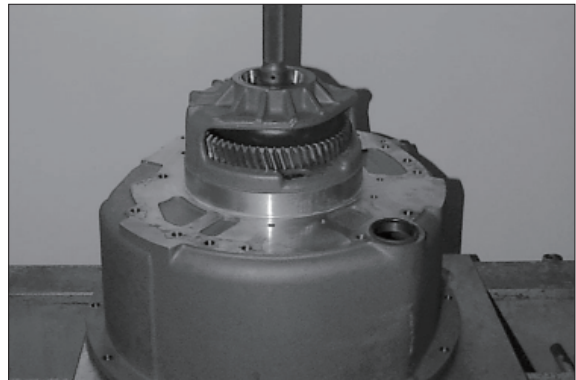

Figure10

(8) Press off the bearing inner ring from the spur gear.

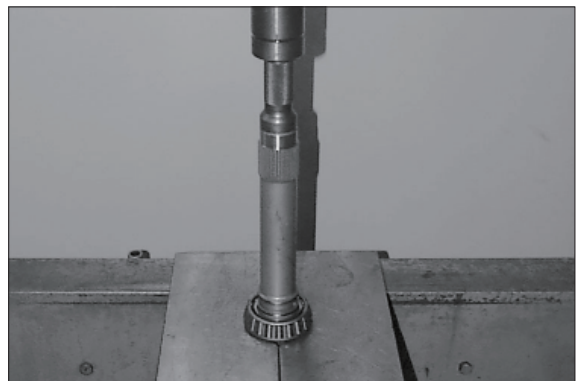

Figure11

(9) Remove the converter pressure back-up valve.

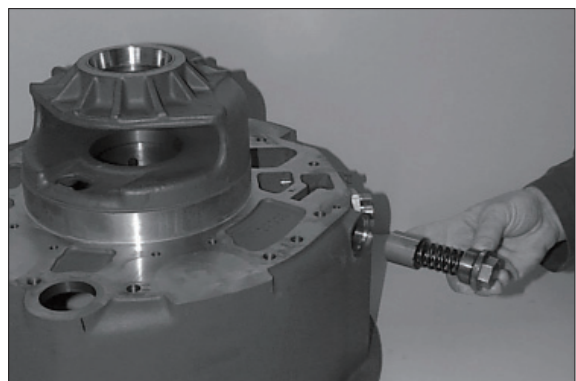

Figure 12

- (10) Remove the inductive transmitter.
9 = n - Engine

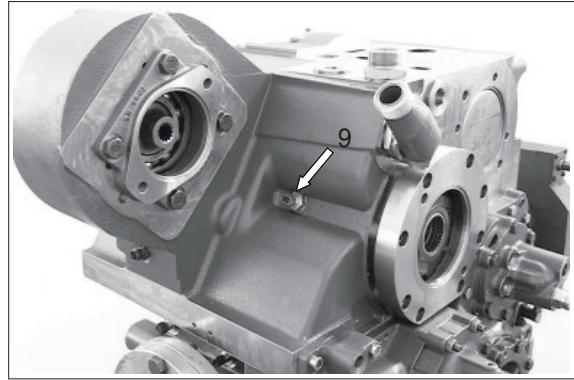

Figure 13

Input shaft - pump/power take-off

- (1) Loosen the cap screw.

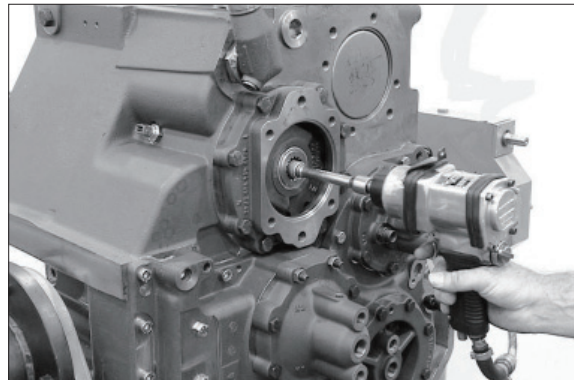

Figure 21

- (2) Remove the cap screw and clamping plate.

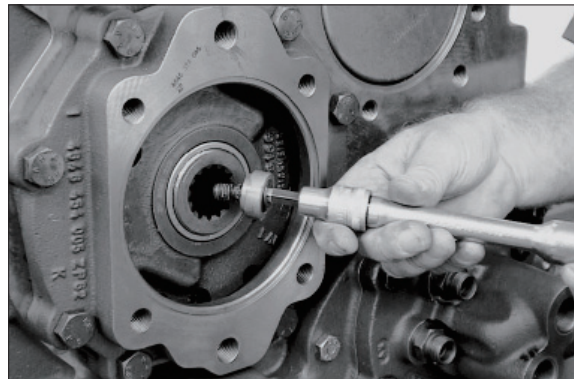

Figure 22

- (3) Press the input shaft out of the bearing.

※ Pay attention to released input shaft as well as shims.

※ Special tool
Extractor

5870 000 065



Figure 23

- (4) Snap out the rectangular ring (arrow 1) and remove both shims (arrow 2).

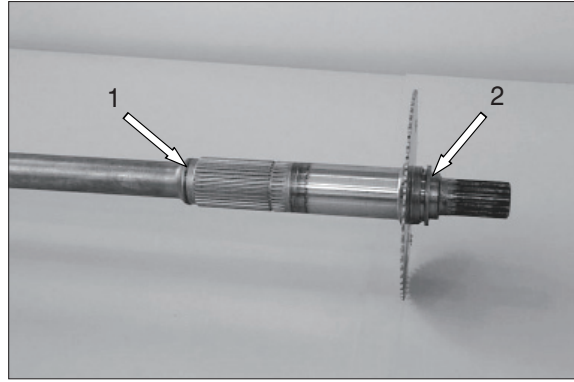

Figure 24

Transmission pump

- (1) Loosen the cap and hexagon screws (depending on the version) respectively and separate the pump flange from the housing.

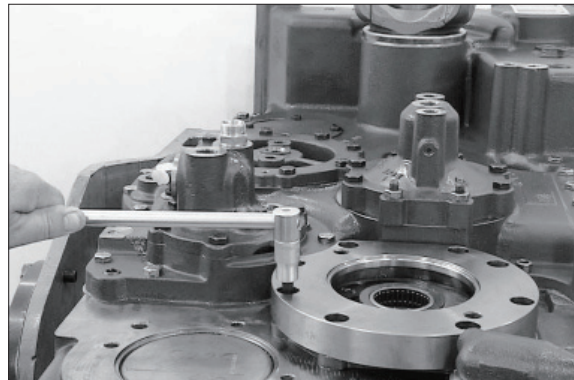

Figure 25

- (2) Loosen the cap screws (4EA / M8).
Position the extractor on the transmission pump and fasten it by means of screws (M8 × 65) to the transmission pump. Then pull out the pump from the housing bore.

※ Extracting is supported by slightly tapping onto the transmission housing.

※ Special tool

Extractor 5870 000 089

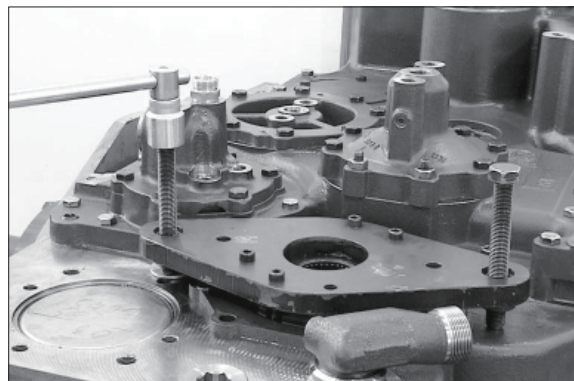

Figure 26

Remove the ball bearing and the driver (figure 28~29)

- (3) Snap out the retaining ring.



Figure 28

- (4) Press out the driver with ball bearing from the bearing bore.
Then separate the ball bearing from the driver.

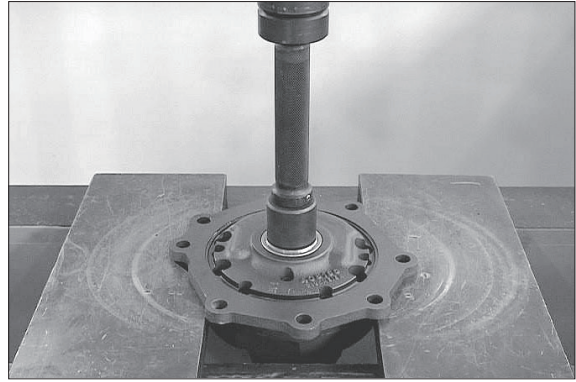

Figure 29

- (5) Loosen the cap screws, take off the pump cover and remove the rotor set.

▲ If marks due to running-in are found on the pump housing or housing cover, the complete pump is to be replaced.

Then assemble the rotor set with the chamfer on the tooth tip showing downwards and install the housing cover again.

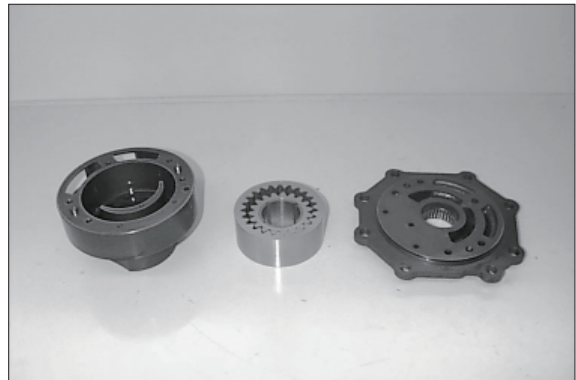

Figure 30

- Torque limit (M8/8.8) :
2.35 kgf · m (17.0 lbf · ft)
- Torque limit (M6/8.8) :
0.97 kgf · m (7.01 lbf · ft)

Layshaft

- (1) Remove the sealing cover and loosen the hexagon screw.

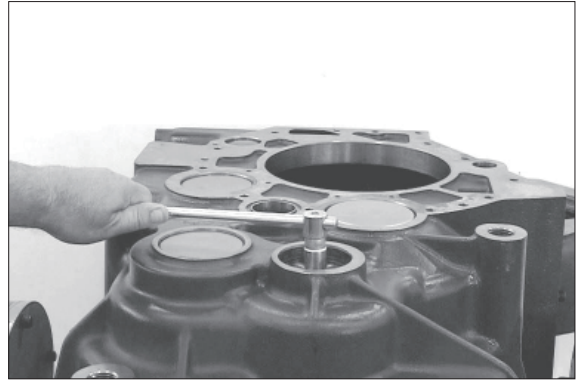

Figure 38

- (2) Expel the idler shaft by means of the striker from the housing bore and layshaft bearing respectively.

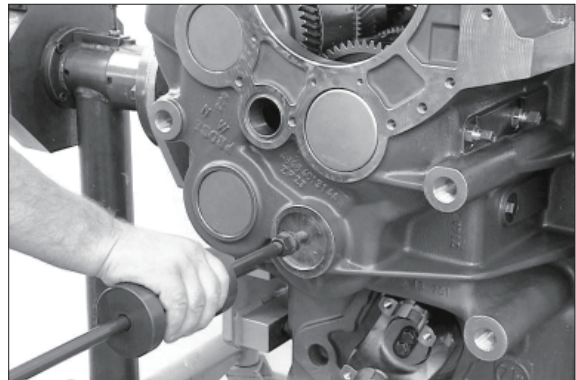

Figure 39

Removal of inductive and speed transmitter (figure 40~41)

- 14 = n - Turbine
- 5 = n - Internal speed input
- 13 = n - Output (speed transmitter)

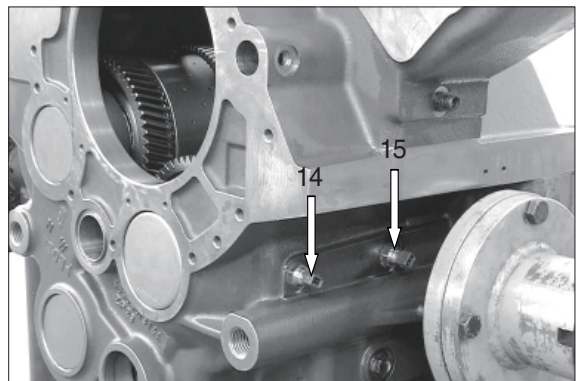

Figure 40

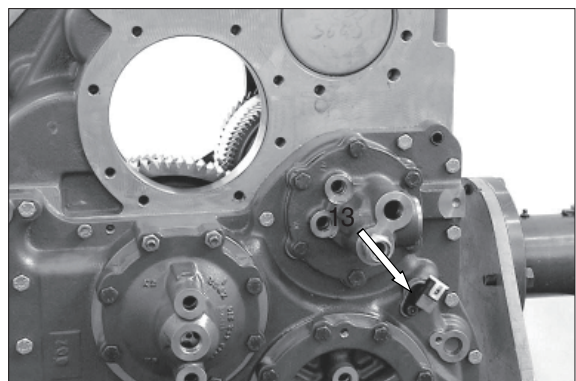

Figure 41

Output

Converter side :

Remove the lock plate. Loosen hexagon screws and take off the output flange. Rotate the housing by 180° and remove the output flange on the housing rear side.

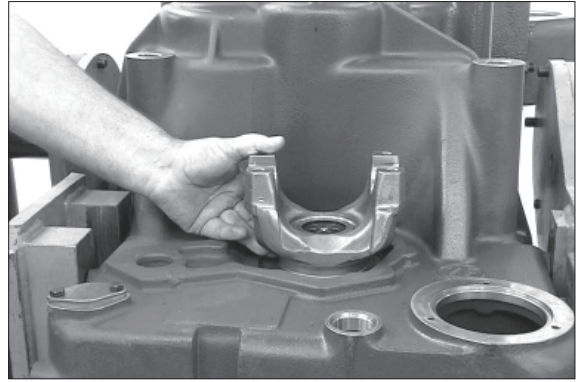

Figure 42

Removal of the clutches and layshaft

- (1) Loosen the hexagon screws and expel the bearing cover KV/K1 by means of the striker from the housing bore. Remove the bearing cover KR/K2 (arrow) analogously.

※ Mark the installation location of the bearing cover.

※ Special tool

Threaded insert 5870 204 069

Striker 5870 650 014

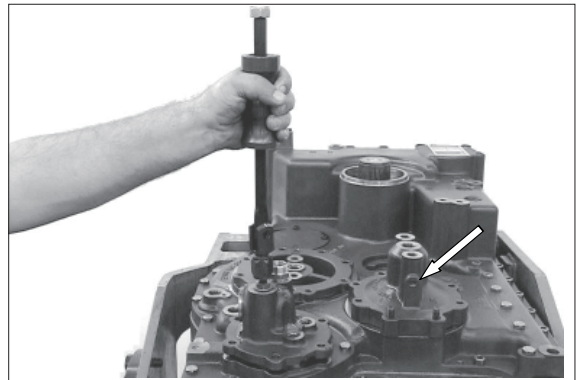

Figure 46

- (2) Pull out the bearing cover K4/K3 by means of the forcing screws from the housing bore.

※ Special tool

Forcing screws 5870 204 005

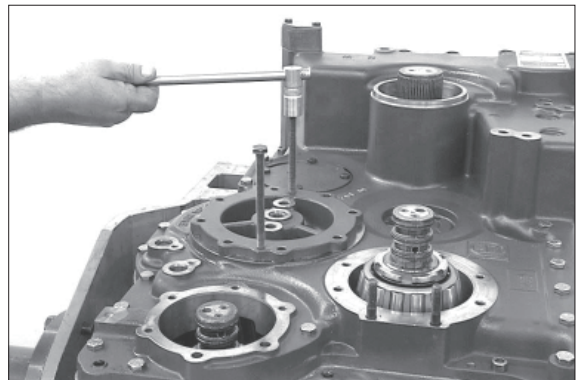

Figure 47

- (3) Separate the bearing inner ring from bearing cover K4/K3.

※ Special tool

Three-armed puller 5870 971 003



Figure 48

- (4) Loosen the bolt connection.
Separate the housing cover from the housing by equally tightening both forcing screws (arrow 1 and 2) as well as the threaded spindle (arrow 3).

※ Special tool	
Internal hex spanner, size 8	5870 290 003
Forcing screws	5870 204 005
Lifting tackle	5870 281 061

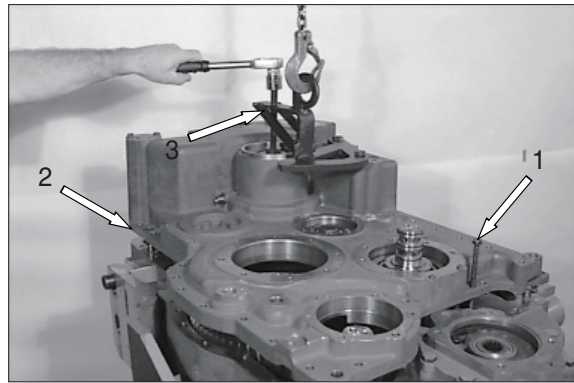

Figure 49

- (5) Expel the output shaft from the output gear.

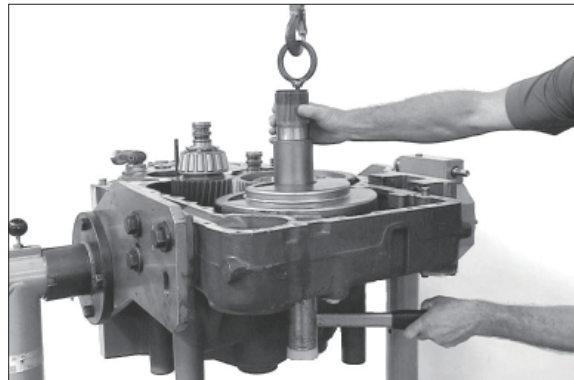

Figure 50

- (6) Loosen the hexagon screws and remove the oil baffle.
Lift the output gear out of the transmission housing (figure).

※ Special tool	
Stop washer	5870 100 054
Eyebolts assortment	5870 204 002

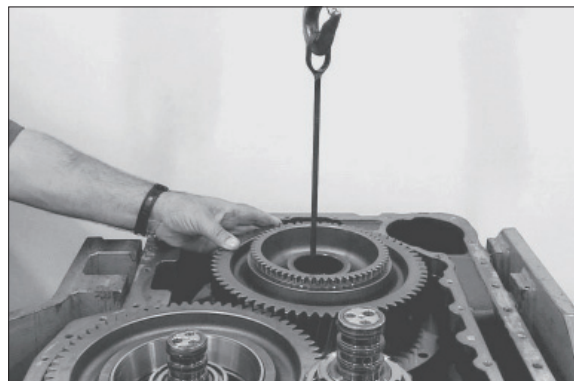

Figure 51

- (7) Remove the bearing inner ring from the output gear.

※ Special tool	
Three-armed puller	5870 971 003

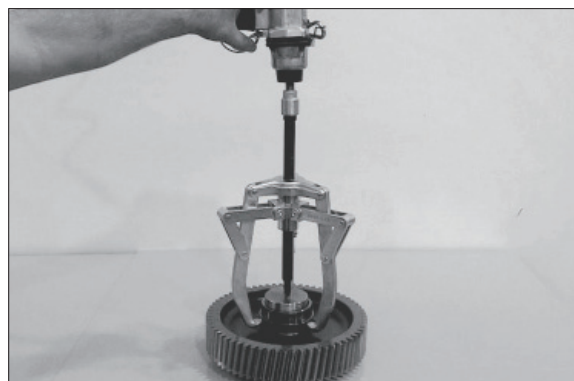

Figure 52

- (8) Take the roller bearing out of the housing bore and remove the oil baffle (arrow).

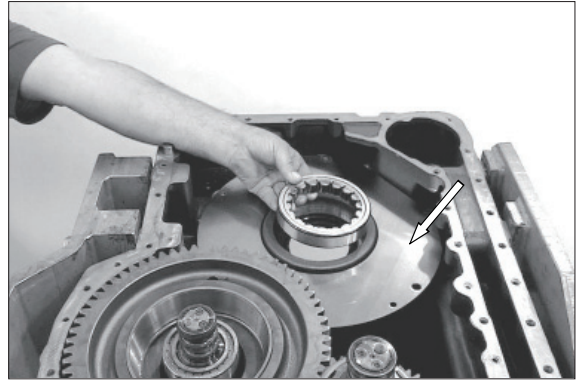

Figure 53

Remove the multi-disc clutches

- ※ For removal of the single clutches observe the following sequence :
K4/K3 KR/K2 KV/K1.
For removal of clutch K4/K3, lift the clutch KR/K2 slightly and move it in direction of the arrow, see figure.
- ※ Special tool
Eyebolts assortment 5870 204 002

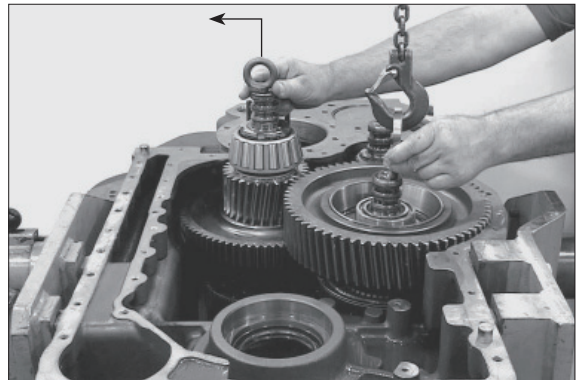

Figure 54

- (9) Opposite figure shows the clutches when removed.

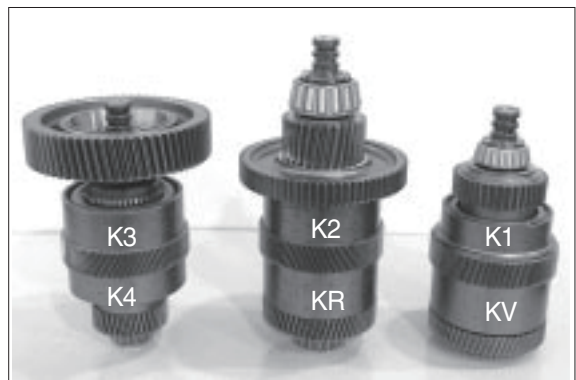

Figure 55

- (10) Remove the layshaft gear.

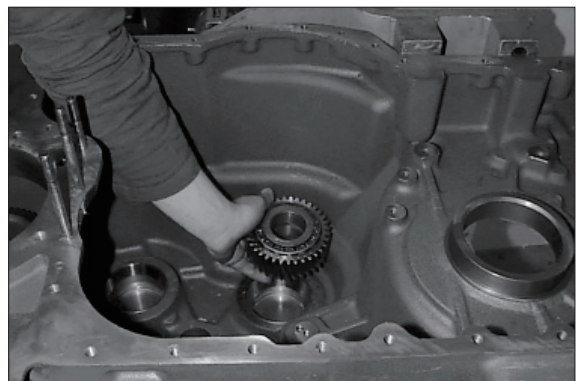

Figure 56

Dismantling of the Multi-Disc Clutch K3/K4

(1) By means of clamping ring (S) fasten the clutch to the assembly truck.

※ Special tool
Clamping ring 5870 654 033

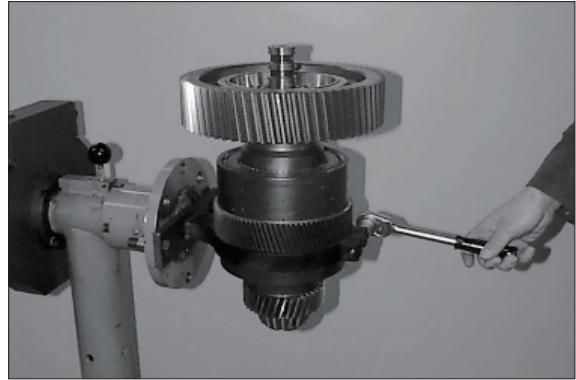

Figure 62

(2) Pull off the roller bearing from the disc carrier.

※ Special tool
Three-armed puller 5870 971 002



Figure 63

(3) Separate spur gear K3 from the disc carrier.



Figure 64

(4) Pull off the bearing inner ring from the disc carrier.

※ Special tool
Rapid grip 5873 012 012
Basic tool 5873 002 001

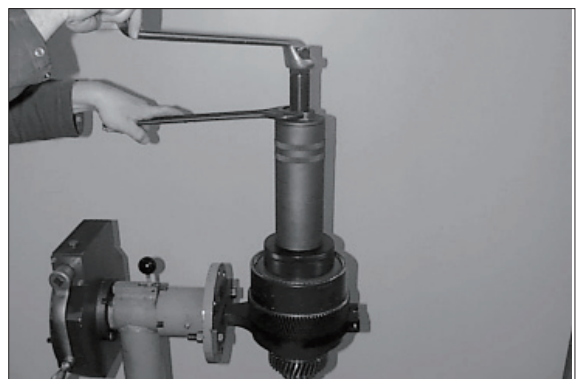

Figure 65

- (5) Squeeze out the snap ring.
Remove the end shim and disc set K3.

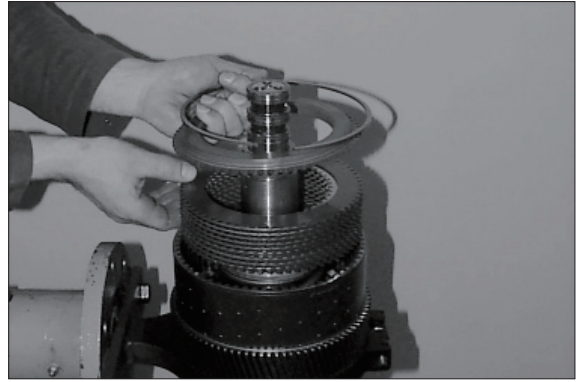

Figure 66

- (6) Rotate disc carrier by 90°.
Loosen the slotted nut.

- ※ Special tool
Slotted nut wrench 5870 401 118
Slotted nut wrench 5870 401 115

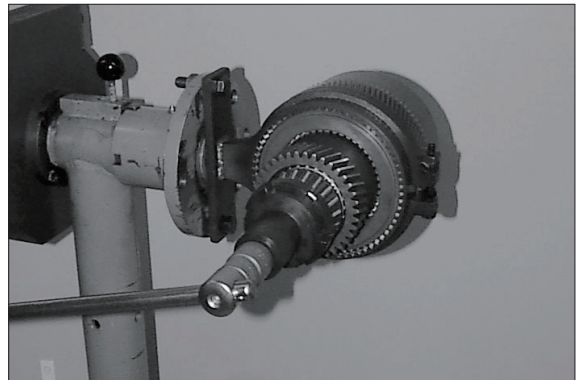

Figure 67

- (7) Rotate disc carrier by 90°.
Pull off the taper roller bearing.

- ※ Special tool
Gripping insert 5873 011 012
Basic tool 5873 001 000



Figure 68

- (8) Pull off the spur gear K4 from the disc carrier.

- ※ Special tool
Three-armed puller 5870 971 003

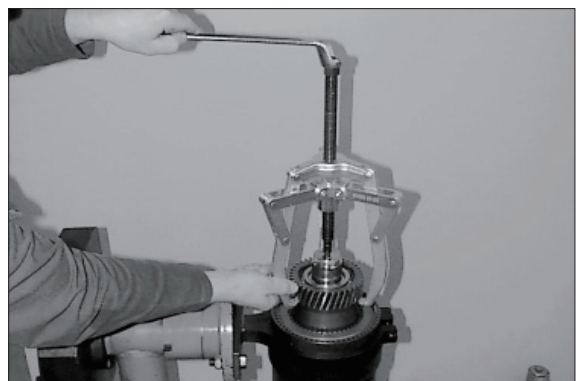

Figure 69

(9) Remove the ring.

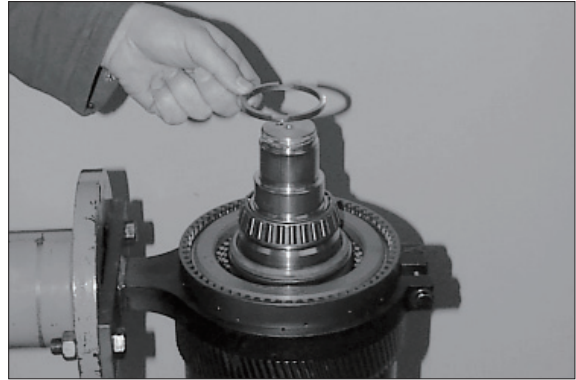

Figure 70

(10) Pull off the taper roller bearing.

※ Special tool
Three-armed puller 5870 971 002

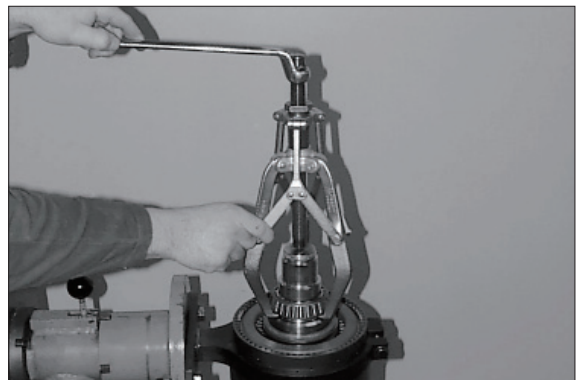

Figure 71

(11) Squeeze out the snap ring.
Remove the end shim and the disc set
K4.

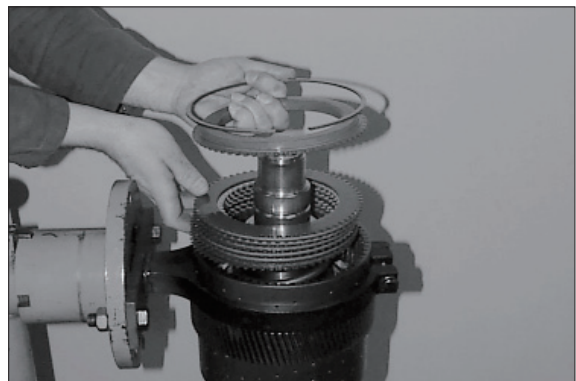

Figure 72

(12) Preload the compression spring by means of fixture (S).
Squeeze out the snap ring and the released single components.
Remove the opposite single components (K3 side) analogously.

※ Special tool
Pressure piece 5870 345 072

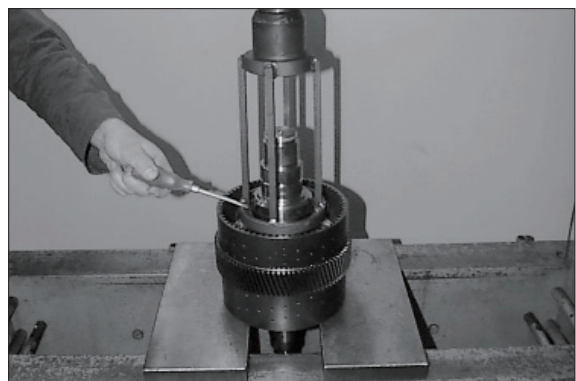

Figure 73

- (13) Separate both pistons by means of compressed air from the disc carrier.

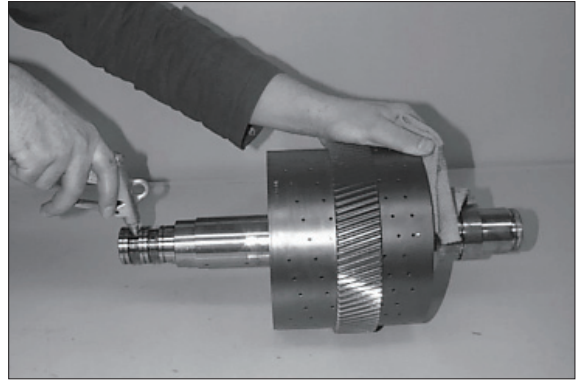

Figure 74

Dismantling of the multi-disc clutch KR/K2

- (1) Fasten the clutch by means of clamping ring (arrow) on the assembly truck.

※ Special tool
Clamping ring 5870 654 033

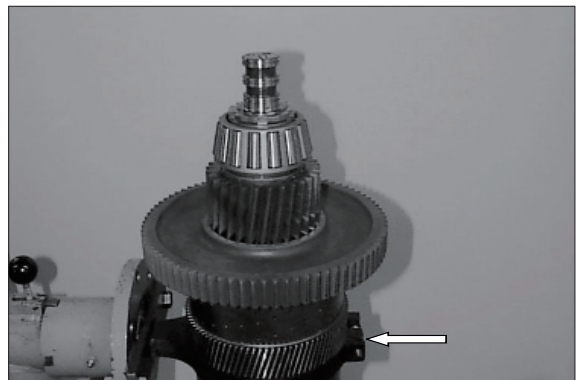

Figure 75

- (2) Rotate disc carrier by 90°. Loosen the slotted nut.

※ Special tool
Slotted nut wrench 5870 401 099

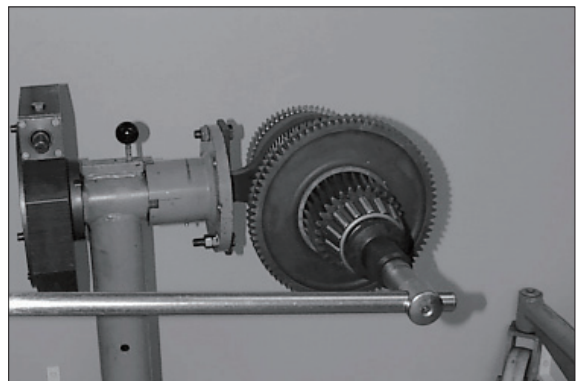

Figure 76

- (3) Pull off the taper roller bearing from the disc carrier.

※ Special tool
Gripping insert 5873 012 018
Basic tool 5873 002 001



Figure 77

- (4) Press off the spur gear K2 from the disc carrier.

▲ Pay attention to released disc carrier.

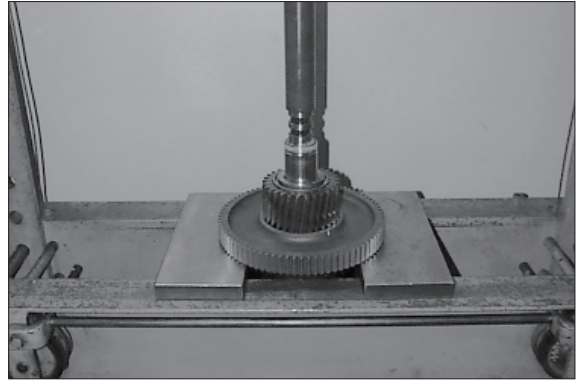

Figure 78

- (5) Fasten the disc carrier by means of clamping ring (S).
Pull off the taper roller bearing from the disc carrier.

※ Special tool
Clamping ring 5870 654 033
Gripping insert 5873 012 019
Basic tool 5873 002 001

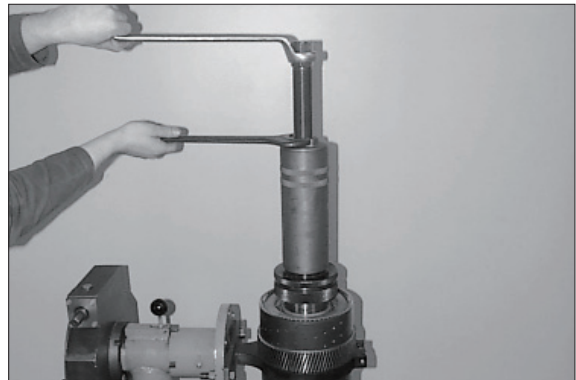

Figure 79

- (6) Squeeze out the snap ring.
Remove the end shim and disc set K2.

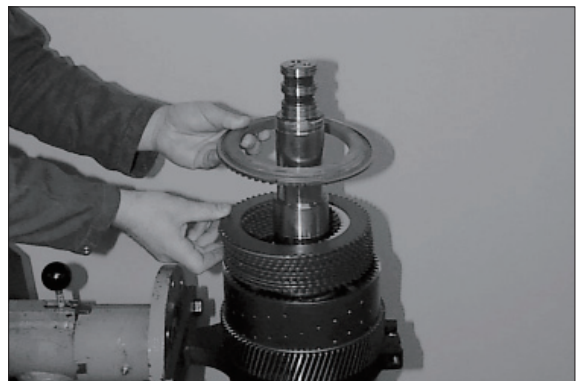

Figure 80

- (7) Rotate disc carrier by 90°.
Loosen the slotted nut.

※ Special tool
Slotted nut wrench 5870 401 099

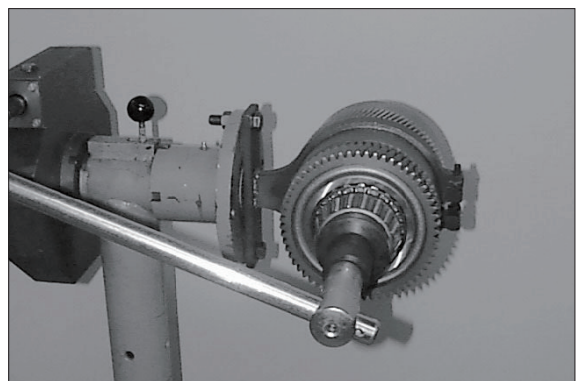

Figure 81

(8) Pull off the taper roller bearing from the disc carrier.

※ Special tool

Gripping insert 5873 002 044

Basic tool 5873 002 001

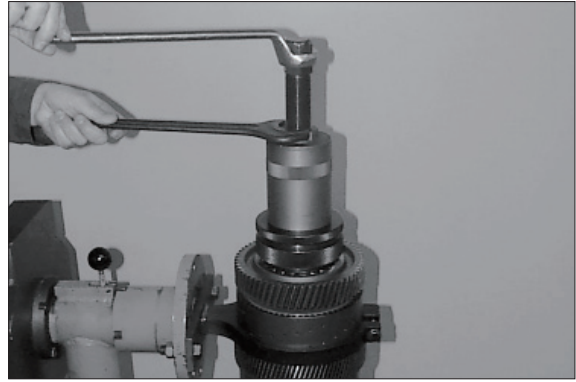

Figure 82

(9) Fasten spur gear KR by means of clamping ring (arrow) and pull it from the disc carrier.

※ Collar of the clamping ring must show upwards (to the spur gear).

※ Special tool

Three-armed puller 5870 971 003

Clamping ring 5870 654 045

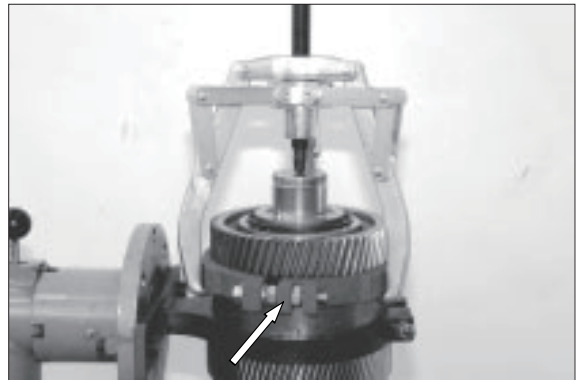

Figure 83

(10) Remove the ring.

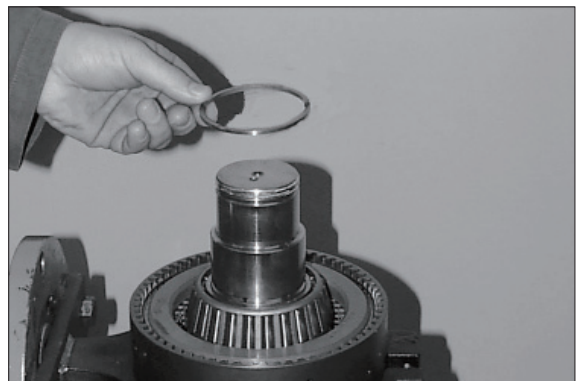

Figure 84

(11) Squeeze out the snap ring.
Remove end shim and disc set KR.



Figure 85

(12) Pull off the taper roller bearing from the disc carrier.

※ Special tool

Gripping insert 5873 012 013

Basic tool 5873 002 001

Remove both piston (like described in figure 73 and 74)

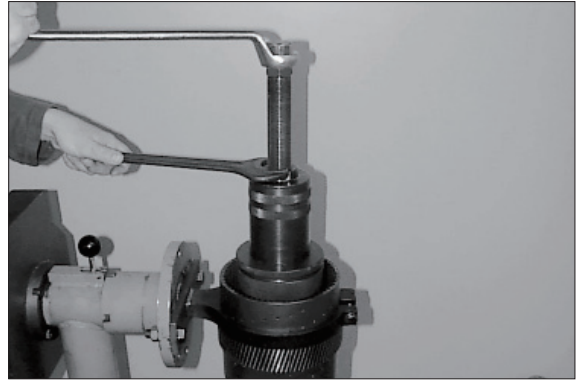

Figure 86

Dismantling of the multi-disc clutch KV/K1

(1) Fasten clutch by means of clamping ring to the assembly truck.

Loosen the slotted nut (figure 87).

※ Special tool

Clamping ring 5870 654 033

Slotted nut wrench 5870 401 118

Slotted nut wrench 5870 401 099

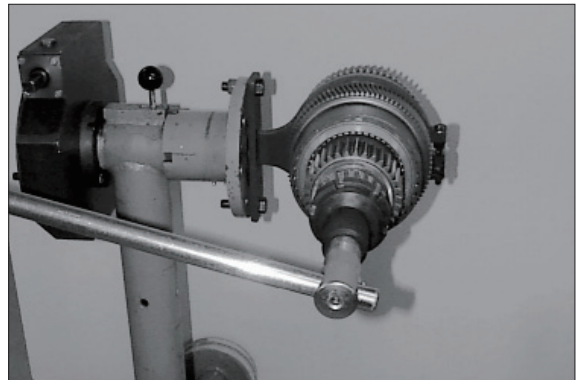

Figure 87

(2) Pull off the taper roller bearing from the disc carrier.

※ Special tool

Gripping insert 5873 001 023

Basic tool 5873 001 000

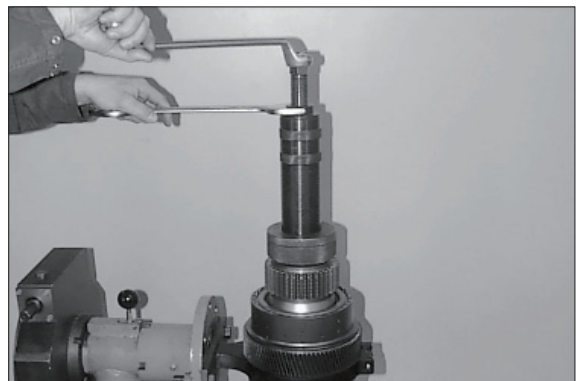

Figure 88

(3) Remove the shim.

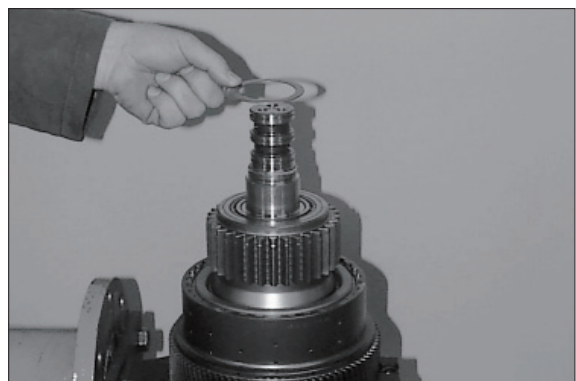

Figure 89

(4) Pull off spur gear K1 from the disc carrier.

※ Special tool

Three-armed puller 5870 971 003

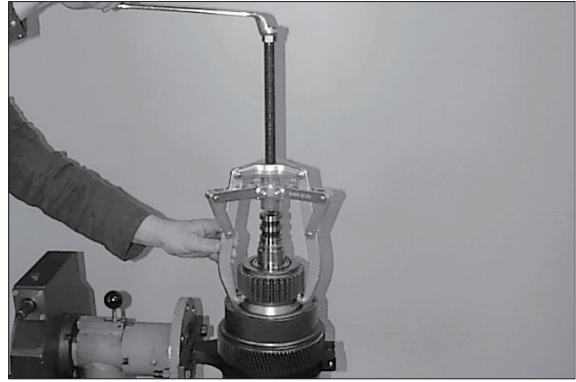

Figure 90

(5) Opposite figure shows the spur gear bearing K1.

Bearing (1) can only be obtained as complete part.

▲ If it is necessary to remove the clutch-pack-sided ball bearing (arrow or Figure 93 and 94), the complete bearing (1) has to be removed.

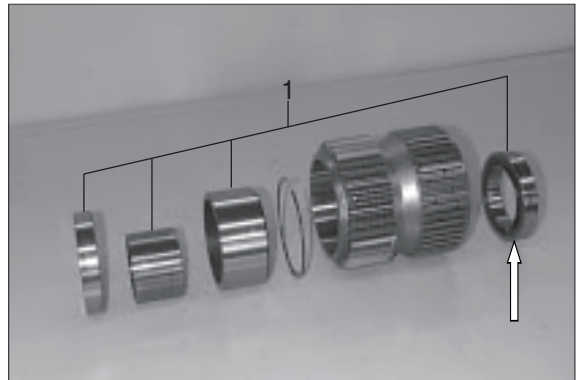

Figure 91

(6) Take off the bush.

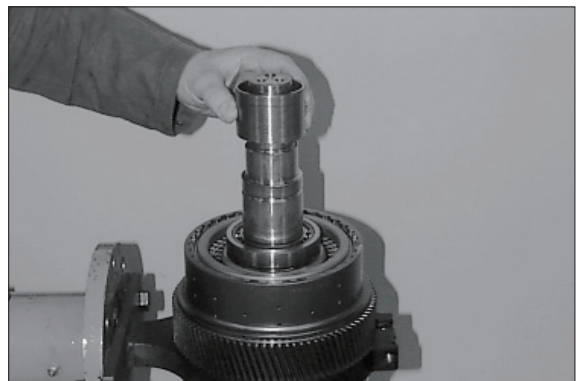

Figure 92

(7) Pull off the ball bearing from the disc carrier (figure 93 and 94).

※ Pay attention to released balls.



Figure 93

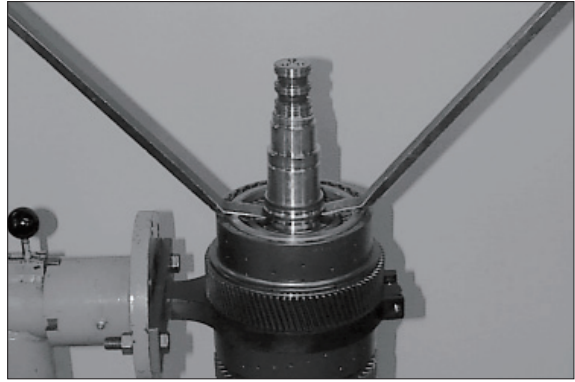

Figure 94

- (8) Squeeze out the snap ring.
Remove end shim and disc set K1.

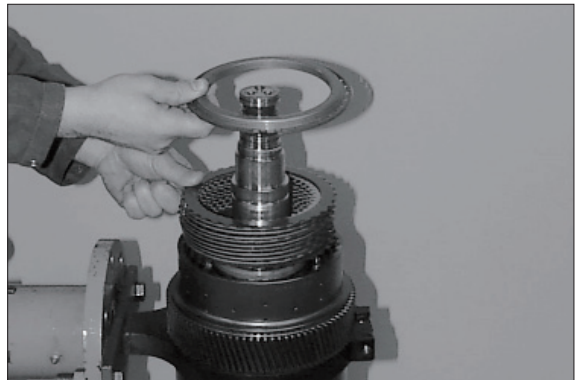

Figure 95

- (9) Rotate disc carrier by 90°.
Loosen the slotted nut.

- ※ Special tool
- Slotted nut wrench 5870 401 118
- Slotted nut wrench 5870 401 115

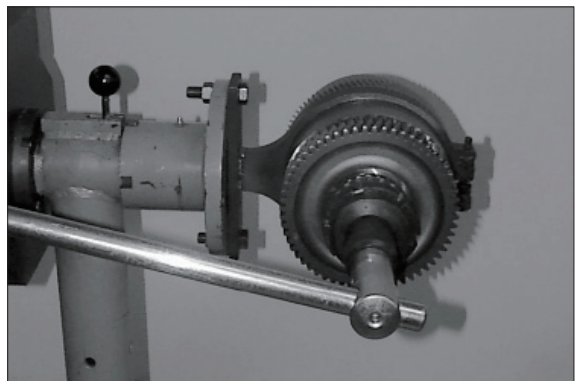

Figure 96

- (10) Pull off the taper roller bearing from the disc carrier.

- ※ Special tool
- Gripping insert 5873 001 034
- Basic tool 5873 001 000

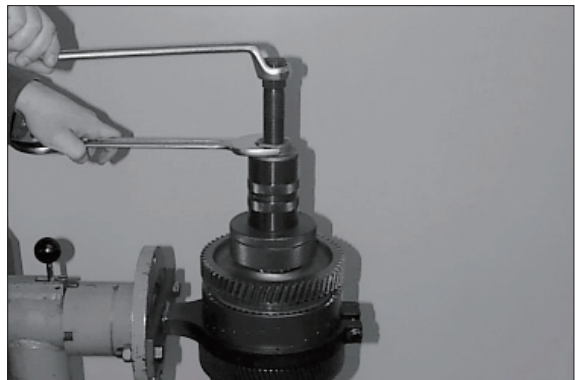

Figure 97

(11) Pull off spur gear KV from the disc carrier.

- ※ Special tool
Three-armed puller 5870 971 003

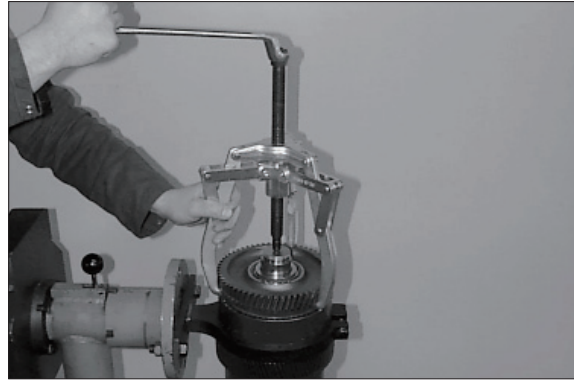

Figure 98

(12) Remove the ring.

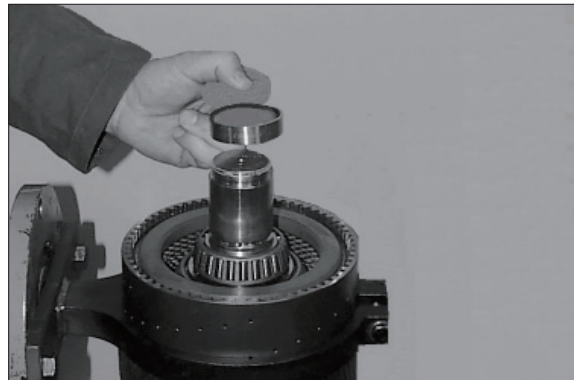

Figure 99

(13) Pull off the taper roller bearing from the disc carrier (figure 100).
Squeeze out the snap ring.
Remove end shim and disc set KV.
Remove both pistons (like described in Figure 73 and 74).

- ※ Special tool
Gripping insert 5873 001 034
Basic tool 5873 001 000

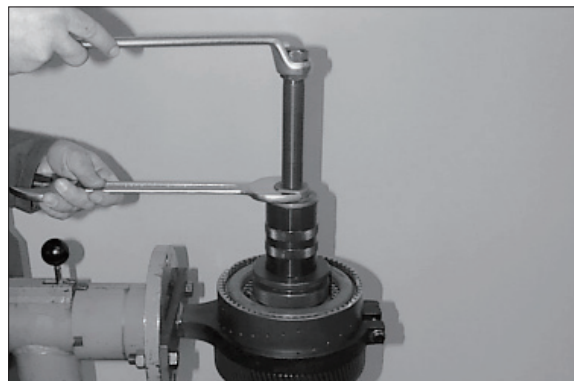

Figure 100

2) ASSEMBLY

Assembly of the multi-disc clutch K4/K3

The following sketch shows the clutch sectioning

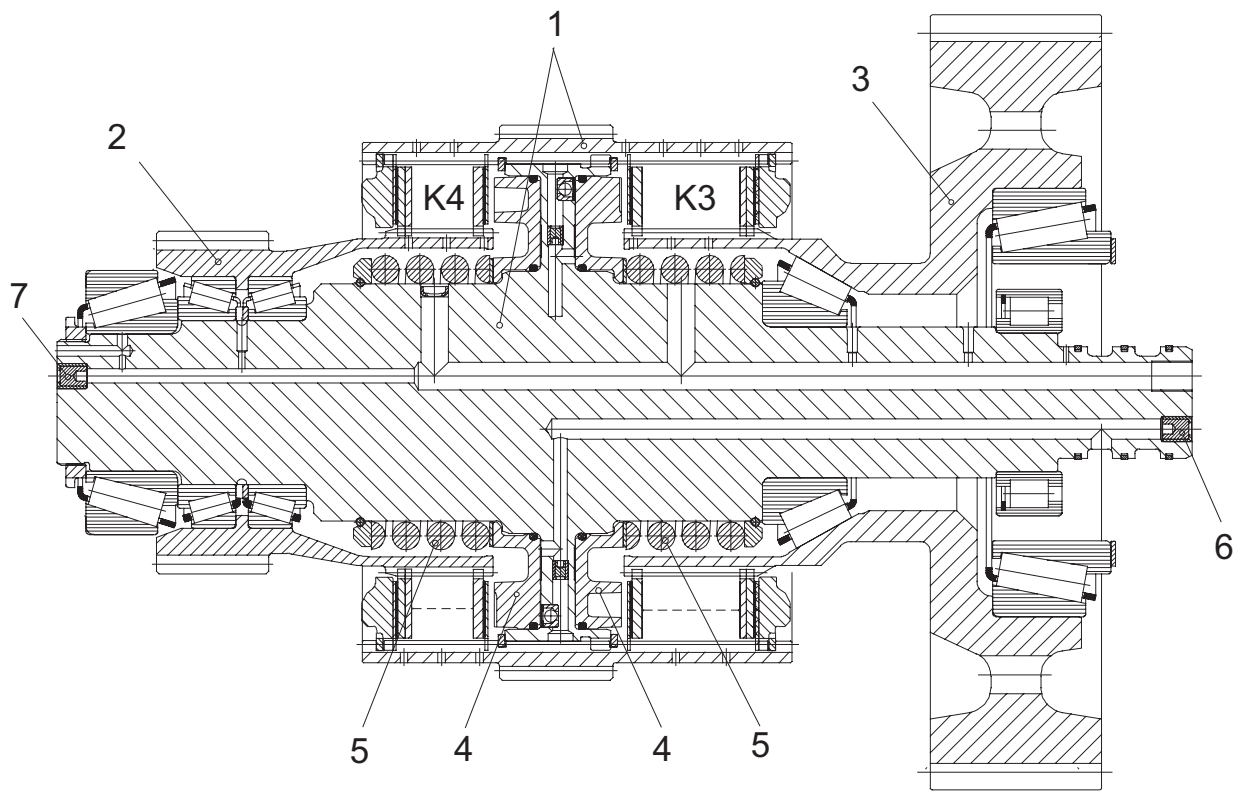

Figure 127

- | | | | | | |
|---|--------------------|----|----------------------|---|--------------------|
| 1 | Disc carrier(assy) | K4 | Multi-disc clutch K4 | 5 | Compression spring |
| 2 | Spur gear K4 | K3 | Multi-disc clutch K3 | 6 | Plug 2EA |
| 3 | Spur gear K3 | 4 | Piston | 7 | Plug 1EA |

※ Observe the installation position of the single components for the following assembly.

- (1) Lift the disc carrier with the K4-side showing downwards into the clamping ring (S) and fasten it.
Rotate disc carrier by 180°.

※ Special tool
Clamping ring 5870 654 033

▲ To install new disc carriers the finished bores have to be sealed with plugs.
Installation position, see arrow, figure 128 and 129.

※ Special tool
Hand inserting tool 5870 320 014
Ratchet spanner 5870 320 018

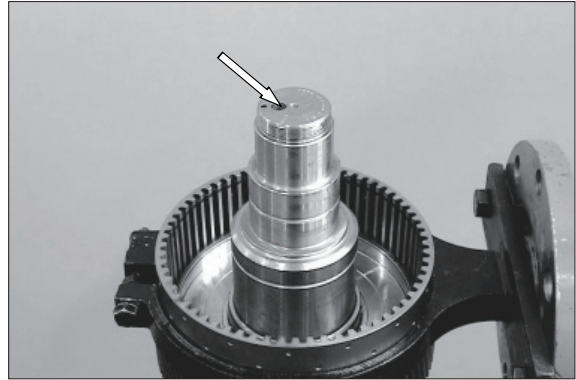

Figure 128

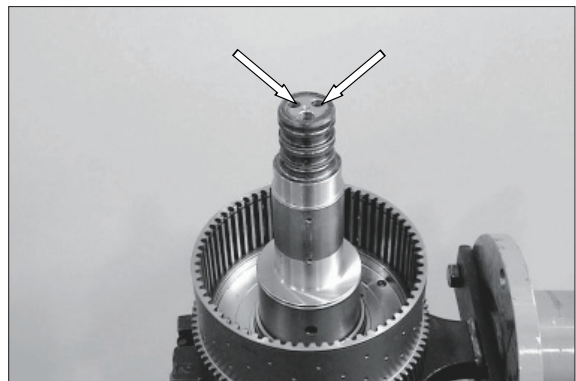

Figure 129

- (2) Flush-mount the drain valve (arrow) with the chamfer showing downwards.

※ Special tool
Inserting tool 5870 320 019

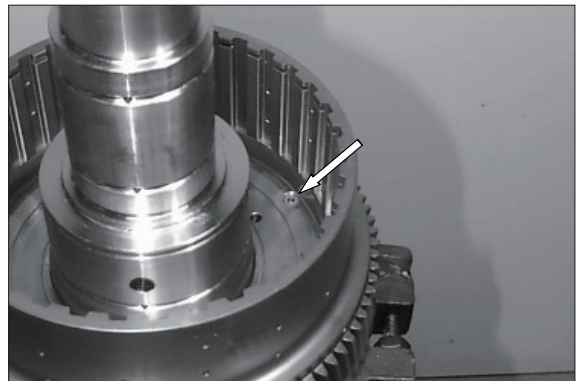

Figure 130

- (3) Put both O-rings scroll-free into the annular grooves of the piston, see arrows.

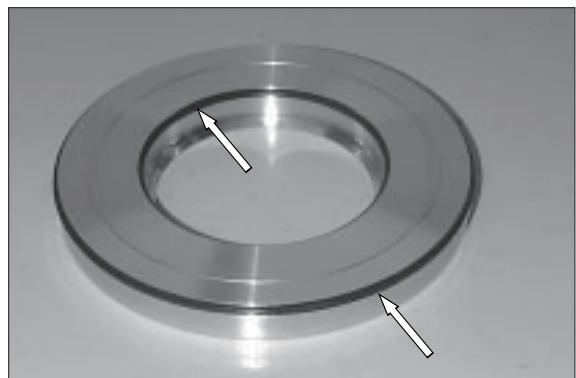

Figure 131

- (4) Oil the O-rings and the piston contact surface.

Install K3 piston equally until contact.

- ※ Observe the installation position of the piston, see figure.

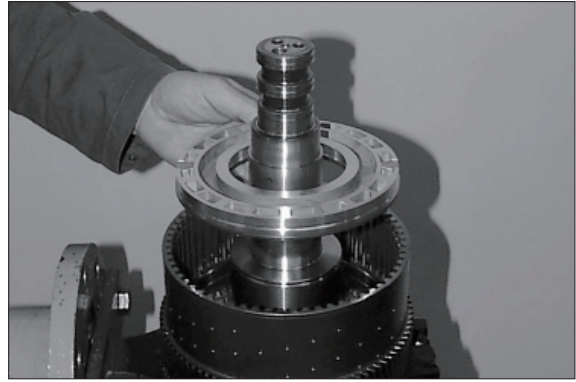

Figure 132

- (5) Install spacer and compression spring.

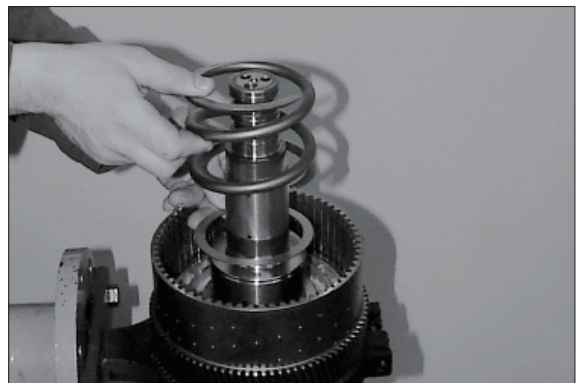

Figure 133

- (6) Place guide ring, with the chamfer (arrow) showing upwards, over the compression spring and install the snap ring.

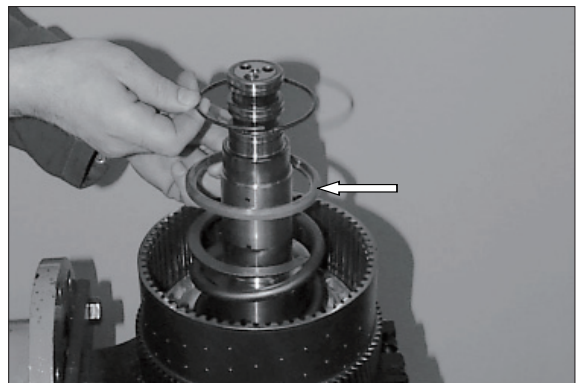

Figure 134

- (7) Lift the disc carrier out of the clamping ring. Preload the compression spring by means of fixture (S) and engage the snap ring into the annular groove of the disc carrier (arrow), see figure 135.

- ※ Special tool

Fixture 5870 345 072

Clamping fixture 5870 654 036

Install the drain valve, piston and compression spring on the opposite side (clutch K4) analogously (figure 130~135).

Then lift the disc carrier with the K4-side showing downwards into the clamping ring and fasten it. Rotate disc carrier by 180°.

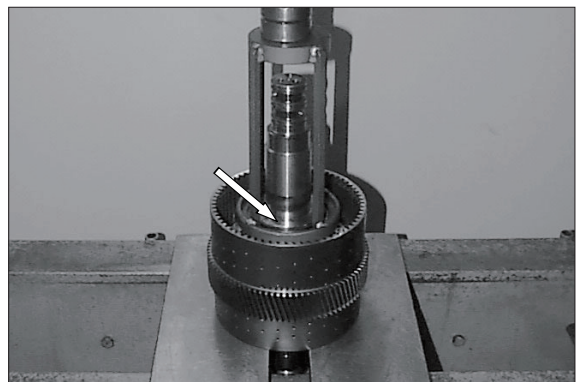

Figure 135

Disc Components K4

※ Below sketch or table shows the standard version as to the installation position of the single components. Obligatory is the respective spare parts list.

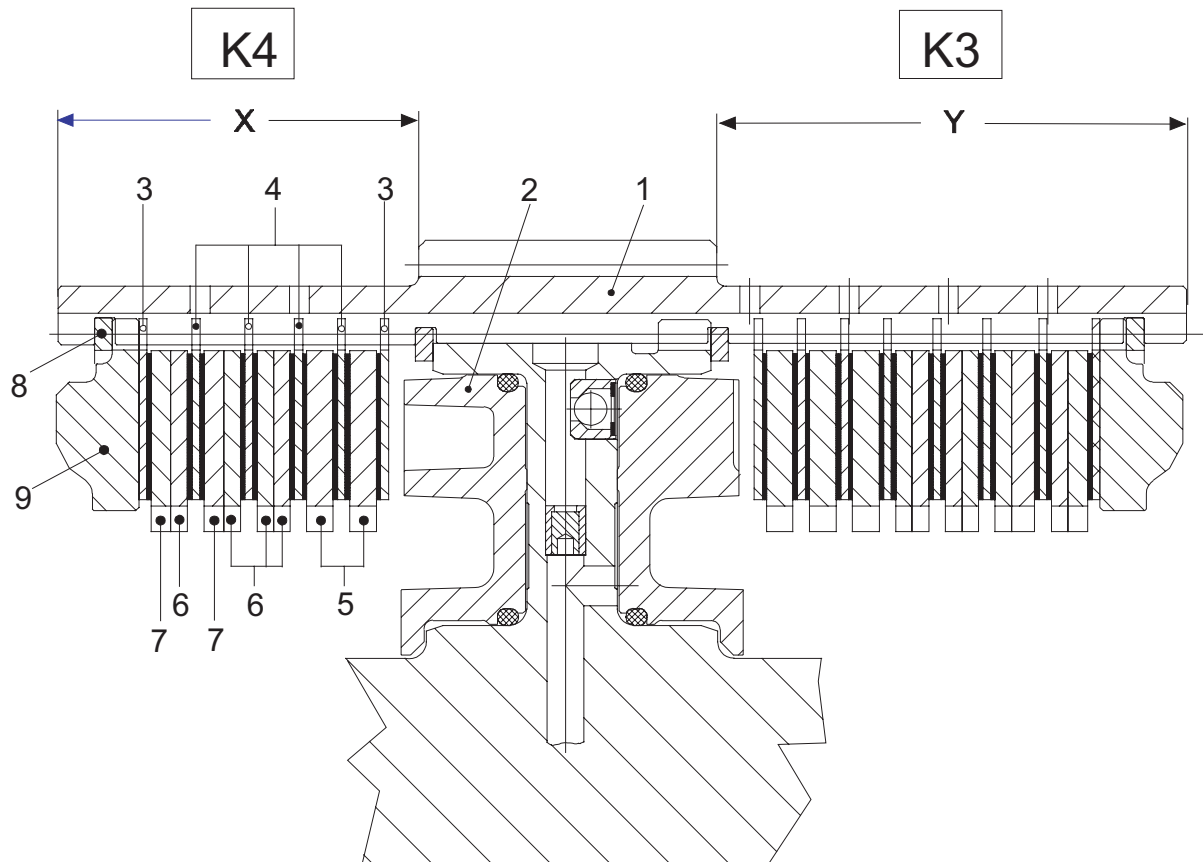

Figure 136

Position	Description	Quantity	s (mm)	Remarks
1	Disc carrier	1		
2	Piston	1		
3	Outer clutch disc	2	1.85	Coated on one side
4	Outer clutch disc	4	2.5	Coated on both sides
5	Inner clutch disc	2	4.0	
6	Inner clutch disc	4	2.5	
7	Inner clutch disc	2	2.5~4.0	Optional
8	Snap ring	1	2.10~3.10	Optional
9	End shim	1		
Number of friction surfaces : 10				
Disc clearance : 2.2 ~ 2.4 mm				

※ Install the outer clutch discs position 3 with uncoated side showing to the piston and end shim respectively. The respective clutch side can be seen on the length of the disc carrier, see sketch.

K4 Dimension X (short disc carrier side)

K3 Dimension Y (long disc carrier side)

Check disc clearance $K_4=2.2\sim 2.4$ mm
(figure 137~139)

※ In order to ensure a perfect measuring result, the disc set is first of all to be installed without oil.

(1) Install disc set according to sketch or table (page 3-104).

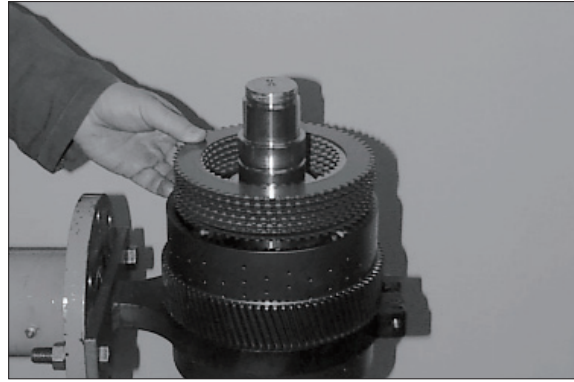

Figure137

(2) Install the end shim and fasten it by means of the snap ring.

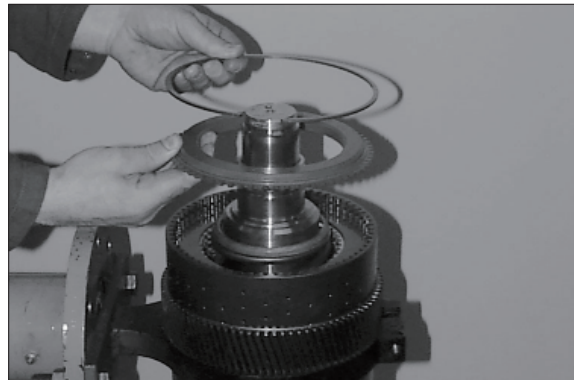

Figure138

(3) Press on end shim with approximately 100N (10 kg) and set dial indicator to "Zero".

Then press end shim against snap ring (upwards) and read disc clearance on the dial indicator.

※ If the required disc clearance differs, it has to be corrected with the adequate inner clutch disc or/and snap ring, see table/ position 7 and position 8.

Upon setting of disc clearance, remove the disc set, oil the clutch discs and reinstall them.

※ Special tool

Magnetic stand 5870 200 055

Dial indicator 5870 200 057

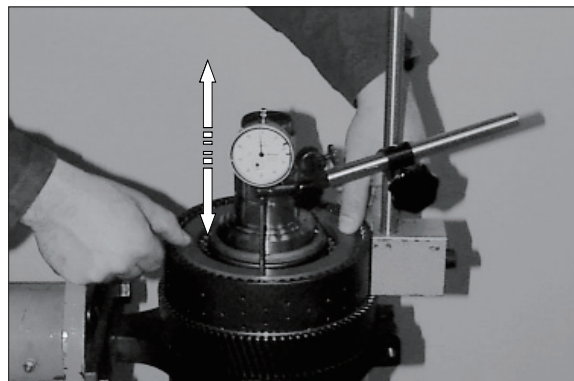

Figure139

Preassemble and install spur gear K4 (figure 140~144) :

(1) Opposite figure shows the single components of spur gear K4.

- 1 Bearing inner ring
- 2 Bearing outer ring
- 3 Ring
- 4 Spur gear

Locate both bearing outer rings (2) until contact.

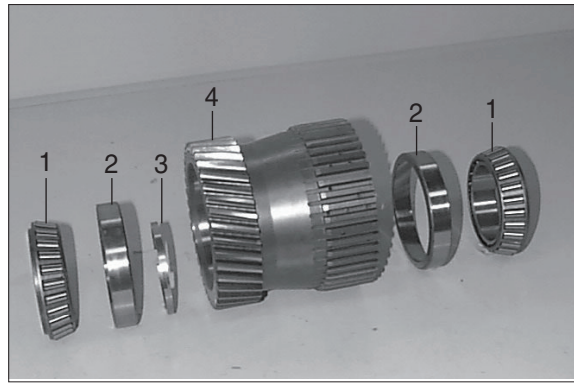

Figure140

(2) Heat the bearing inner ring and install it until contact.



Figure141

(3) Install the ring (3).

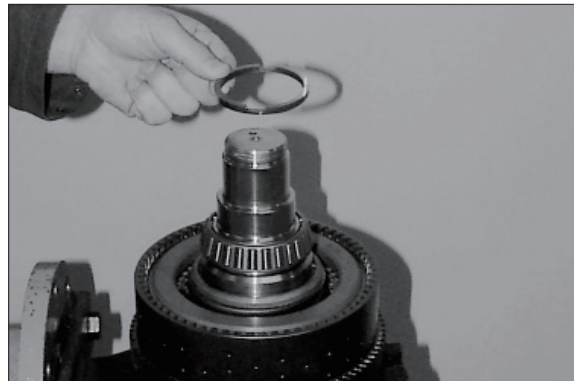

Figure142

(4) Assemble the spur gear until all inner clutch discs are located.

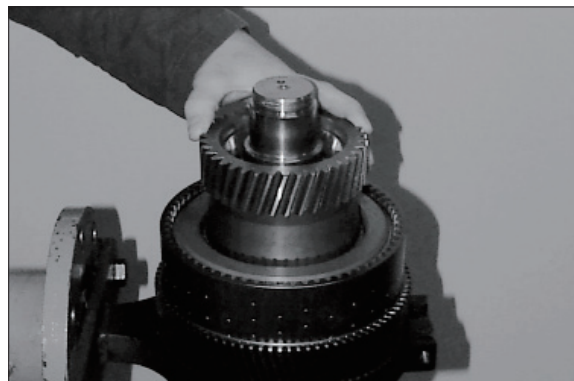

Figure143

(5) Heat the bearing inner ring (spur gear bearing) and locate it until contact.

▲ Use safety gloves.

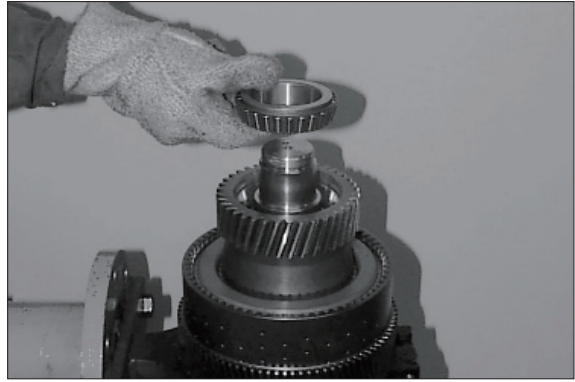

Figure144

(6) Heat the bearing inner ring (clutch bearing) and install it until contact.

▲ Use safety gloves.

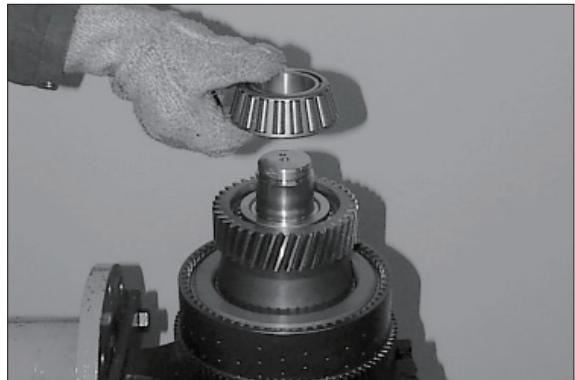

Figure145

Clutch Components K3

※ Below sketch or table shows the standard version as to the installation position of the single components. Obligatory is the respective spare parts list.

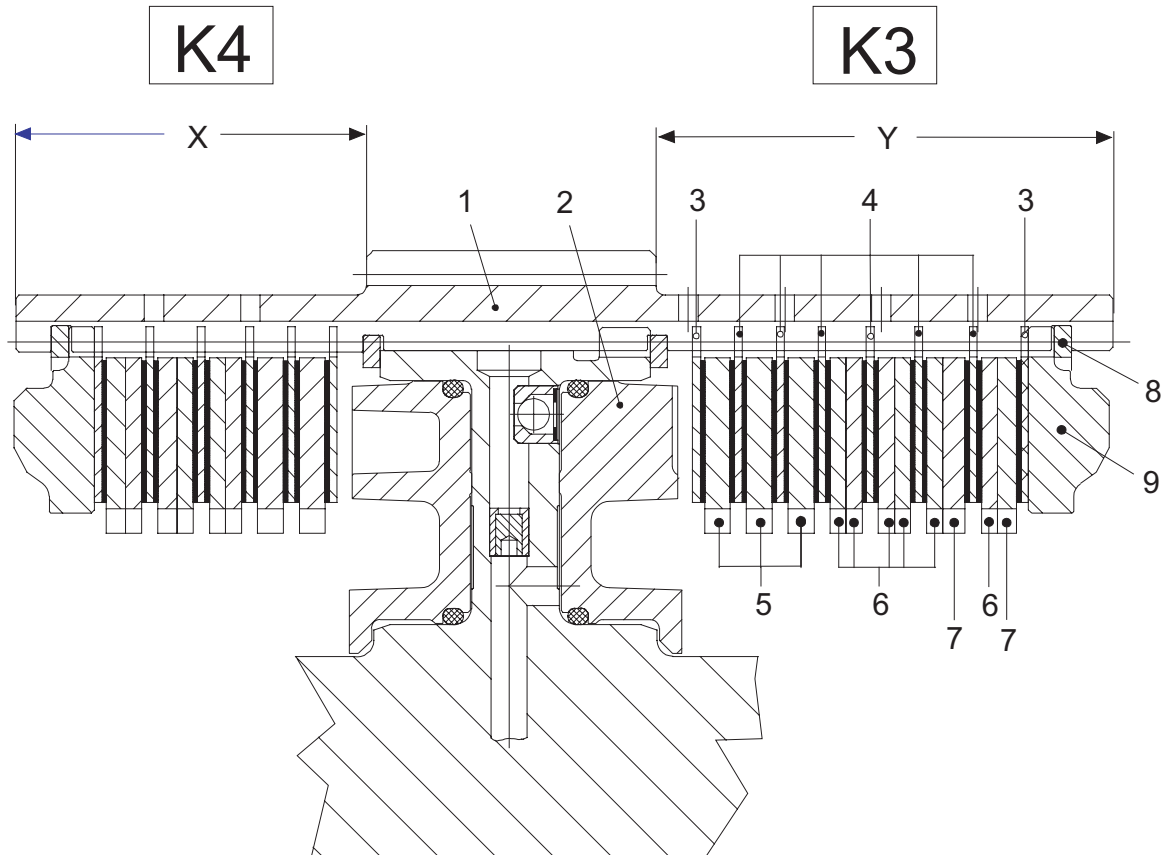

Figure146

Position	Description	Quantity	s(mm)	Remarks
1	Disc carrier	1		
2	Piston	1		
3	Outer clutch disc	2	1.85	Coated on one side
4	Outer clutch disc	6	2.5	Coated on both sides
5	Inner clutch disc	3	4.0	
6	Inner clutch disc	6	2.5	
7	Inner clutch disc	2	2.5~4.0	Optional
8	Snap ring	1	2.10~3.10	Optional
9	End shim	1		
Number of friction surfaces : 14				
Disc clearance : 2.2 ~ 2.4mm				

※ Install the outer clutch discs position 3 with uncoated side showing to the piston and end shim respectively. The respective clutch side can be seen on the length of the disc carrier, see sketch.

K3 Dimension Y (long disc carrier side)

K4 Dimension X (short disc carrier side)

Check disc clearance $K3=2.2\sim 2.4$ mm
(figure 147~149)

※ In order to ensure a perfect measuring result, the disc set is first of all to be installed without oil.

(1) Install disc set according to sketch or table (page 3-108).

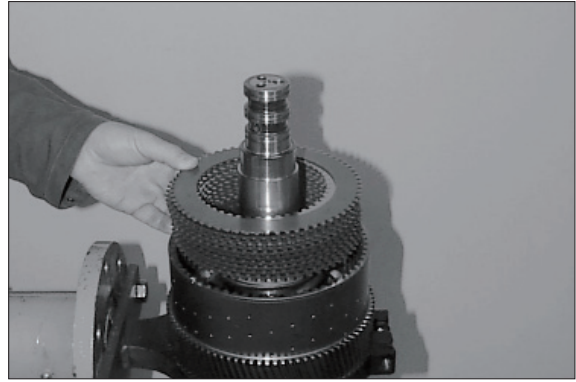

Figure 147

(2) Install the end shim and fasten it by means of the snap ring.

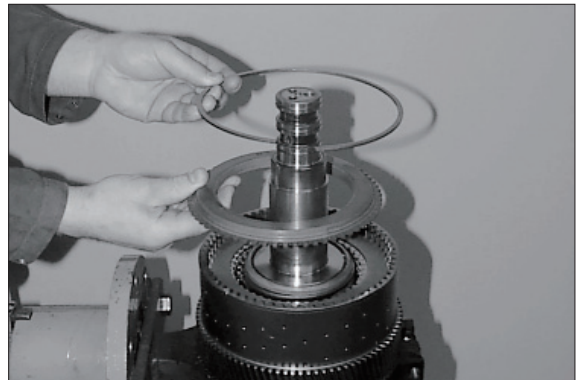

Figure 148

(3) Press on end shim with approximately 100N (10 kg) and set dial indicator to "Zero".

Then press end shim against snap ring (upwards) and read disc clearance on the dial indicator.

※ If the required disc clearance differs, it has to be corrected with the adequate inner clutch disc or/and snap ring, see table/ position 7 and position 8.

Upon setting of disc clearance, remove the disc set, oil the clutch discs and reinstall them.

※ Special tool

※ Magnetic stand 5870 200 055

Dial indicator 5870 200 057

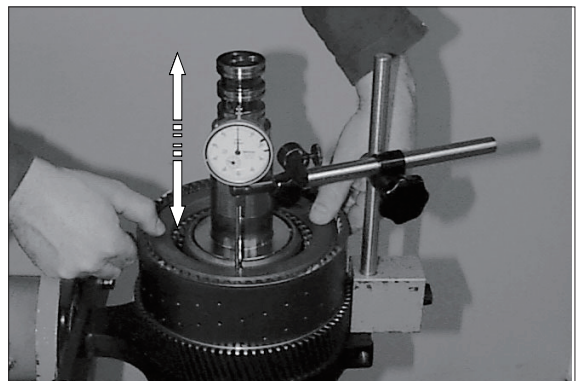

Figure 149

(4) Heat the bearing inner ring and install it until contact.

▲ Use safety gloves.

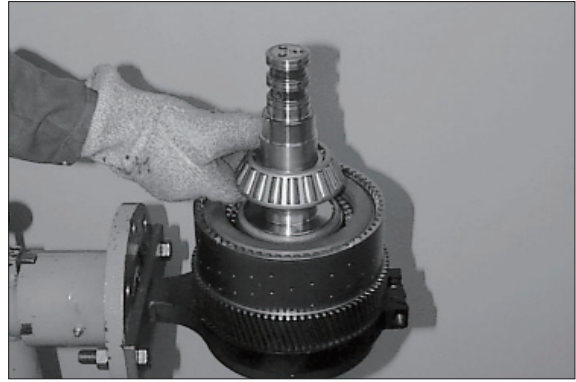

Figure 150

(5) Lift the disc carrier out of the clamping ring (S).

To ensure the exact locating of the single components, preload the bearing with 100KN (10 t) (figure 151)

▲ Support on the lower as well as upper bearing inner ring.
Use pressure pieces (S).

※ Special tool

Pressure piece 5870 506 096

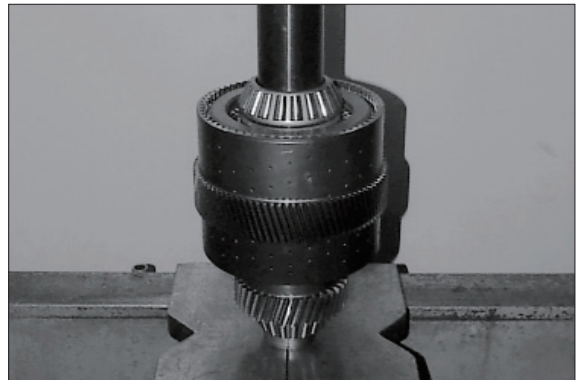

Figure 151

(6) Lift the disc carrier with the K4-side showing downwards into the clamping ring (S) and fasten it.

Rotate disc carrier by 90°.
Install the slotted nut.

※ Observe installation position of the slotted nut. Collar (∅ 60 mm) must show to the bearing inner ring, also see sketch/page 3-101. Oil the thread.

· Tightening torque : 56.1 kgf · m (406 lbf · ft)

※ Special tool

Clamping ring 5870 654 033

Slotted nut wrench 5870 401 118

Slotted nut wrench 5870 401 115



Figure 152

- (7) Install the bearing outer ring into spur gear K3 until contact.

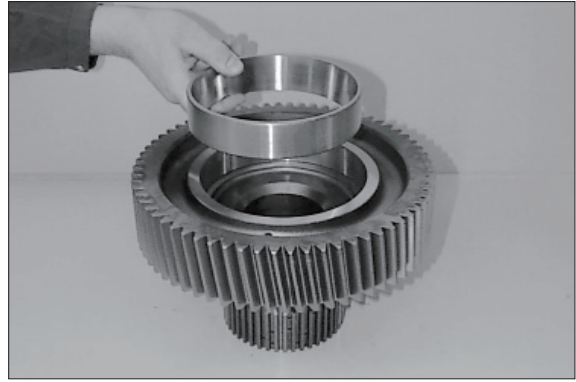

Figure 153

- (8) Assemble the spur gear until all inner clutch discs are located.

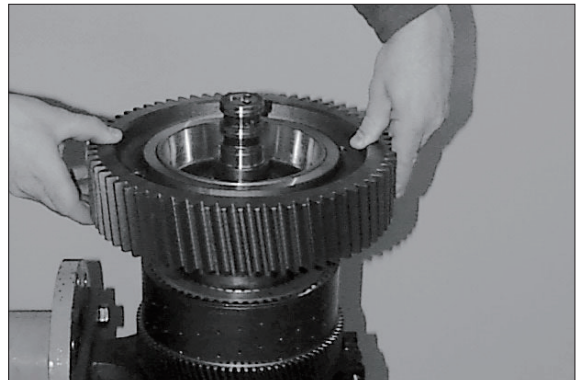

Figure 154

- (9) Heat the roller bearing and locate it until contact.

▲ Use safety gloves.

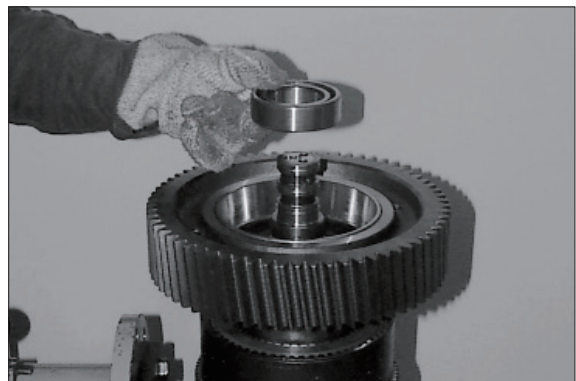

Figure 155

- (10) Install the bearing inner ring.

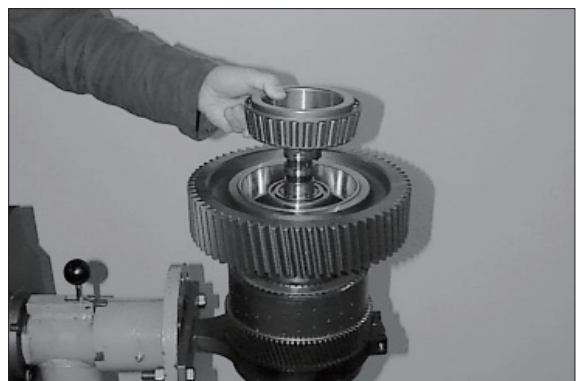

Figure 156

(11) Check function of the clutches K3 and K4 by means of compressed air.

※ Closing or opening of the clutches is clearly audible when the single parts have been installed adequately.

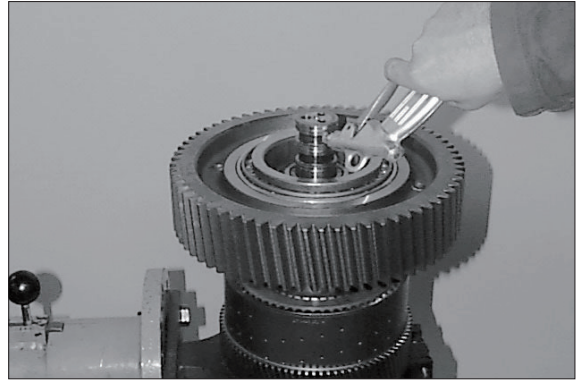

Figure 157

(12) Snap-in and lock the rectangular rings (3EA, see arrows).



Figure 158

Assembly of the multi-disc clutch KR/K2

The following sketch shows the clutch sectioning.

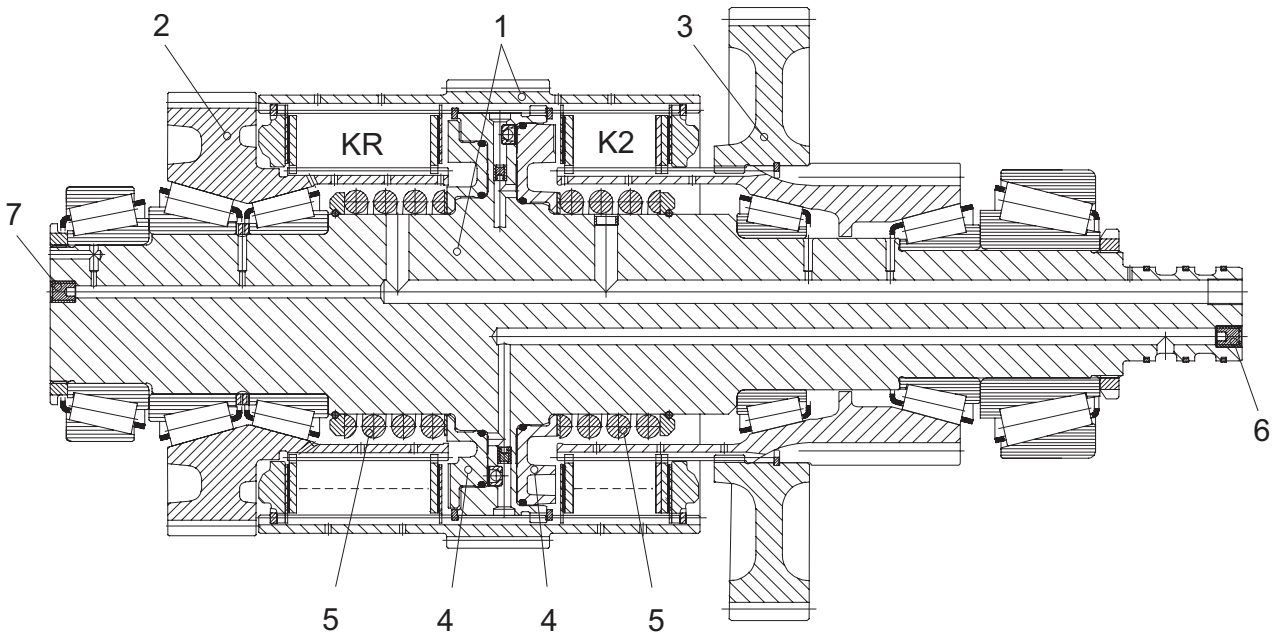

Figure159

- | | | | | | |
|---|--------------|----|----------------------|---|--------------------|
| 1 | Disc carrier | K4 | Multi-disc clutch KR | 5 | Compression spring |
| 2 | Spur gear KR | K3 | Multi-disc clutch K2 | 6 | Plug 2EA |
| 3 | Spur gear K2 | 4 | Piston | 7 | Plug 1EA |

※ Observe the installation position of the single components for the following assembly.

- (1) Lift the disc carrier with the KR-side showing downwards into the clamping ring and fasten it.
Then rotate disc carrier by 180°.

**▲ To install new disc carriers the finished bores have to be sealed with plugs.
Installation position, see arrow, figure 160~161.**

※ Special tool	
Clamping ring	5870 654 033
Hand mounting tool	5870 320 014
Ratchet	5870 320 018

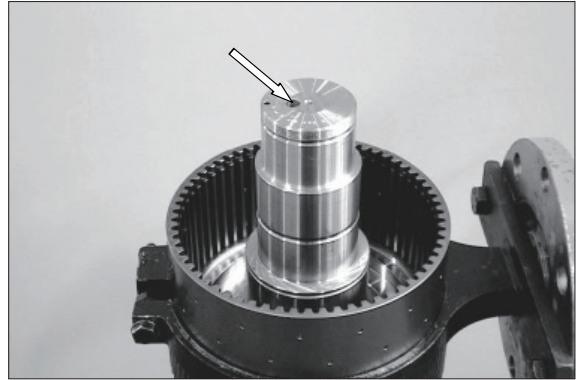

Figure 160

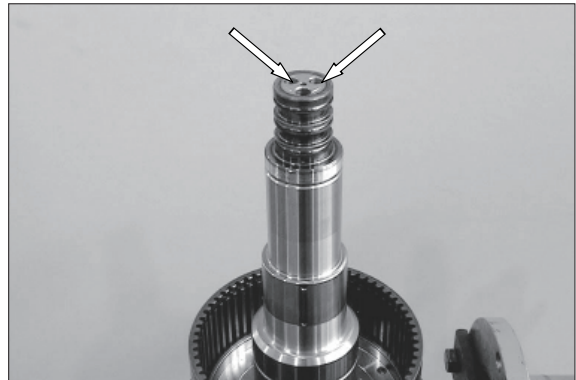

Figure 161

- (2) Flush-mount the drain valve (arrow) with the chamfer showing downwards.

※ Special tool	
Inserting tool	5870 320 019

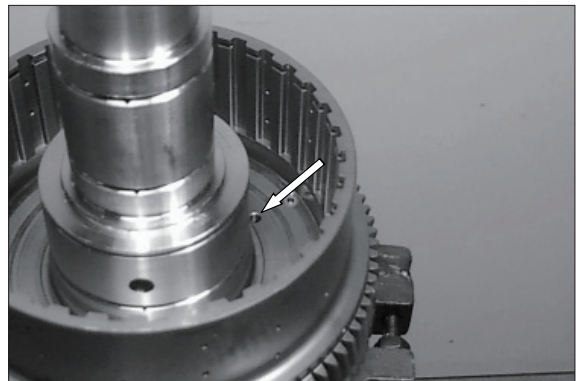

Figure 162

- (3) Put both O-rings scroll-free into the annular grooves of the piston, see arrows.

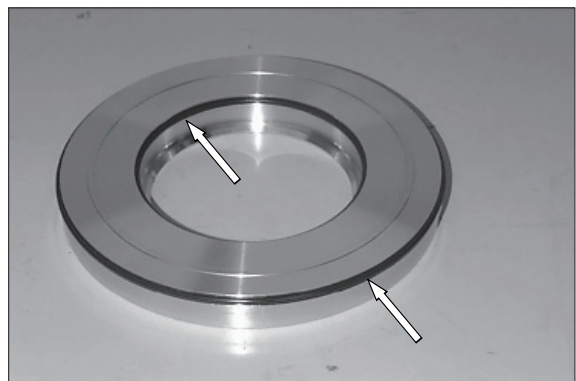

Figure 163

- (4) Oil the O-rings and the piston contact surface.
Install K2 piston equally until contact.
- ※ Observe the installation position of the piston, see figure.

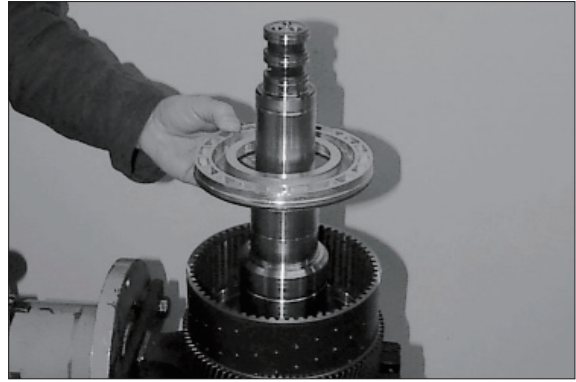

Figure 164

- (5) Install spacer and compression spring.

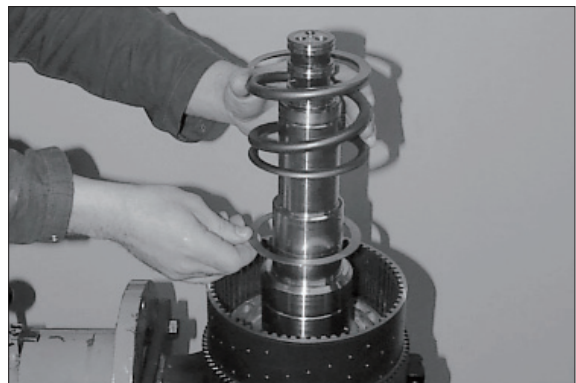

Figure 165

- (6) Place guide ring, with the chamfer (arrow) showing upwards, over the compression spring and install the snap ring.

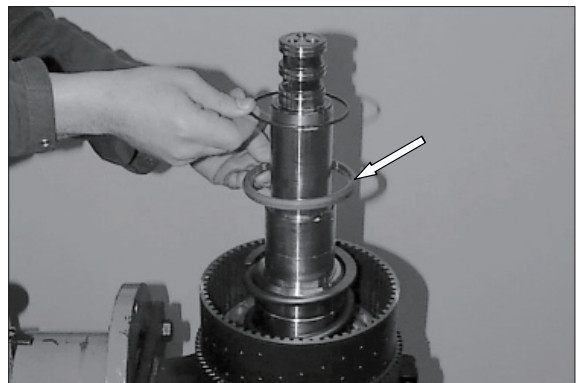

Figure 166

- (7) Lift the disc carrier out of the clamping ring. Preload the compression spring by means of fixture and engage the snap ring into the annular groove of the disc carrier (arrow), see figure 167.
Install the drain valve, piston and compression spring on the opposite side (clutch K4) analogously (like figure 162~167).
Then lift the disc carrier with the KR-side showing downwards into the clamping ring and fasten it. Rotate disc carrier by 180°.

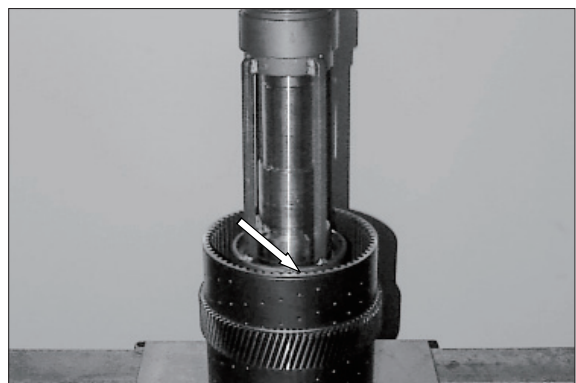

Figure 167

- ※ Special tool
- | | |
|------------------|--------------|
| Pressure piece | 5870 345 072 |
| Clamping fixture | 5870 654 036 |

Disc Components KR

※ Below sketch or table shows the standard version as to the installation position of the single components. Obligatory is the respective spare parts list.

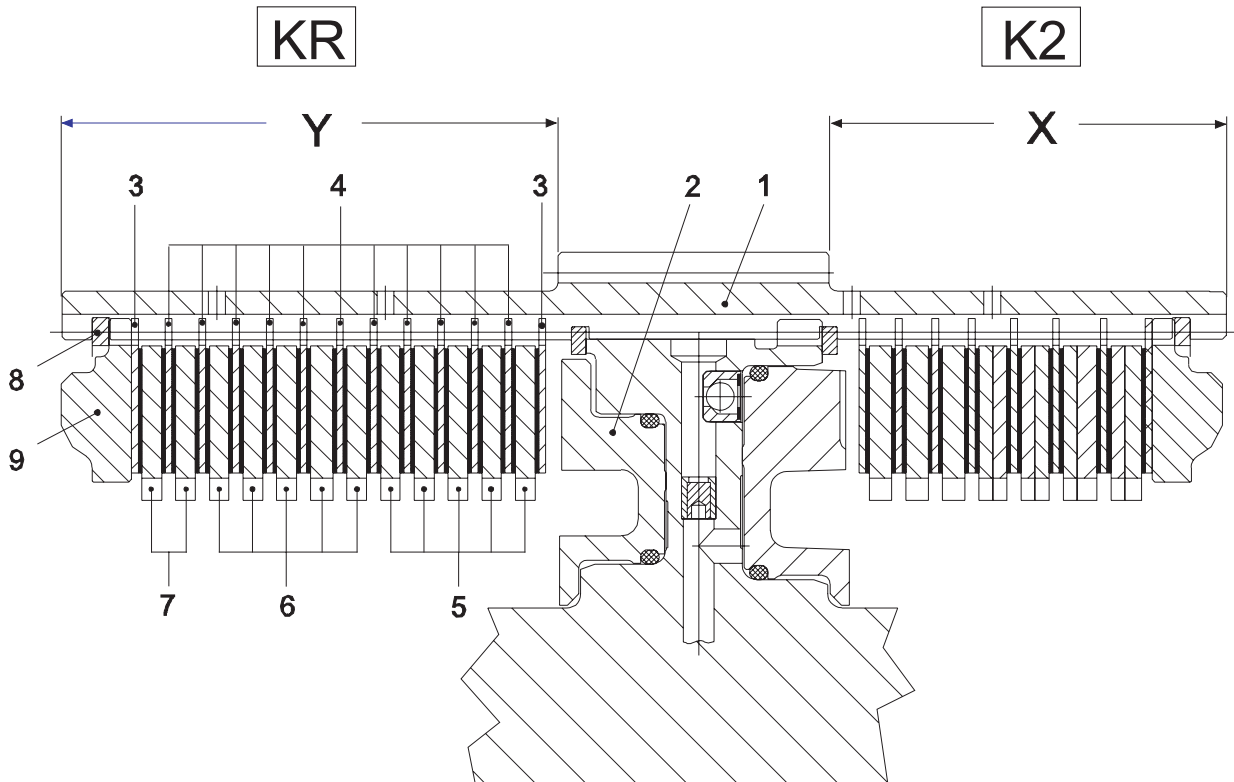

Figure 168

Position	Description	Quantity	s (mm)	Remarks
1	Disc carrier	1		
2	Piston	1		
3	Outer clutch disc	2	1.85	Coated on one side
4	Outer clutch disc	11	3.35	Coated on both sides
5	Inner clutch disc	5	2.5	
6	Inner clutch disc	5	3.0	
7	Inner clutch disc	2	2.5~4.0	Optional
8	Snap ring	1	2.10~3.10	Optional
9	End shim	1		
Number of friction surfaces : 24				
Disc clearance : 2.8 ~ 3.0 mm				

※ Install the outer clutch discs position 3 with uncoated side showing to the piston and end shim respectively. The respective clutch side can be seen on the length of the disc carrier, see sketch.

KR Dimension X (long disc carrier side)

K2 Dimension Y (short disc carrier side)

Check disc clearance KR=2.8~3.0 mm
(figure 169~171)

※ In order to ensure a perfect measuring result, the disc set is first of all to be installed without oil.

(1) Install disc set according to sketch or table (page 3-116).

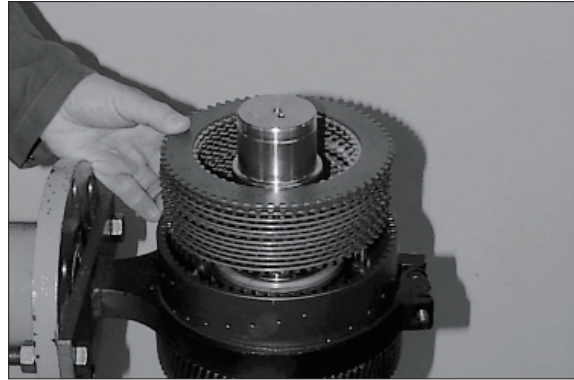

Figure 169

(2) Install the end shim and fasten it by means of the snap ring.

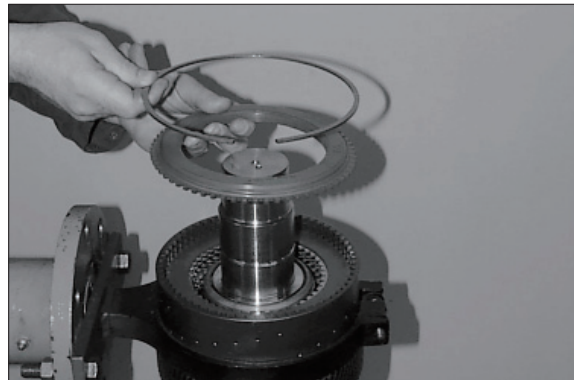

Figure 170

(3) Press on end shim with approximately 100N (10 kg) and set dial indicator to "Zero".

Then press end shim against snap ring (upwards) and read disc clearance on the dial indicator.

※ If the required disc clearance differs, it has to be corrected with the adequate inner clutch disc or/and snap ring, see table/ position 7 and Position 8.

Upon setting of disc clearance, remove the disc set, oil the clutch discs and reinstall them.

※ Special tool

Magnetic stand 5870 200 055

Dial indicator 5870 200 057

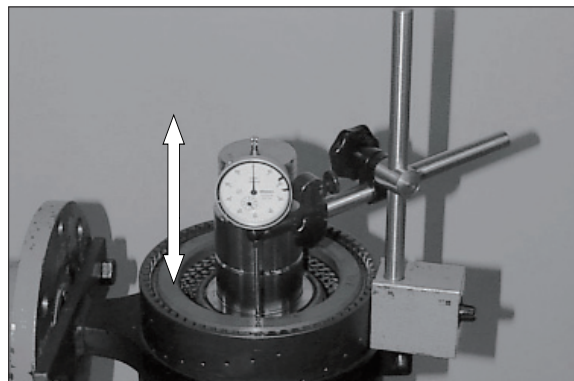

Figure 171

Preassemble and install spur gear KR (figure 172~176) :

(1) Opposite figure shows the single components of spur gear KR.

- 1 Bearing inner ring (75×37 mm)
- 2 Ring
- 3 Spur gear
- 4 Bearing inner ring (75×41 mm)

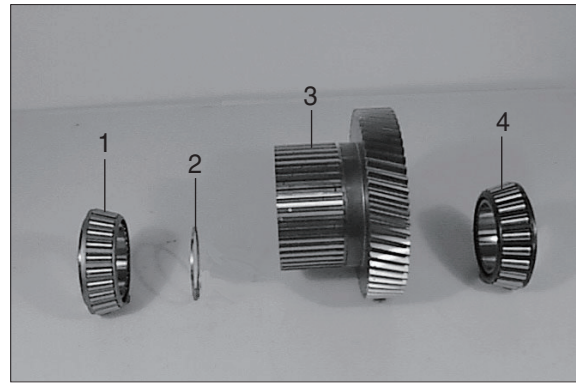

Figure 172

(2) Heat the bearing inner ring (75×37 mm) and install it until contact.

▲ Use safety gloves.

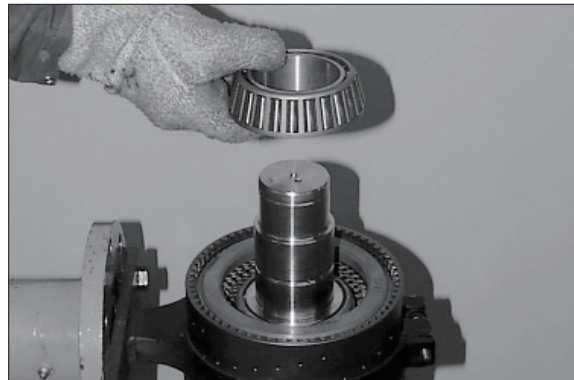

Figure 173

(3) Assemble the spur gear until all inner clutch discs are located.

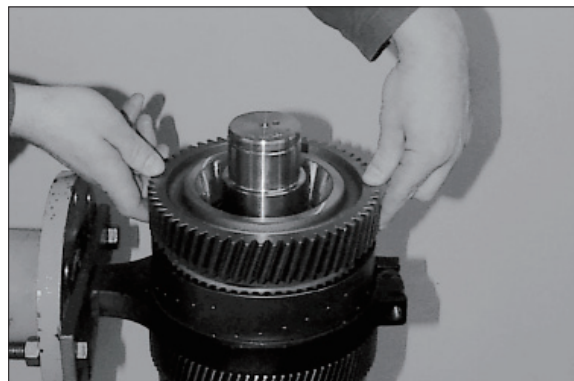

Figure 174

(4) Install the ring.

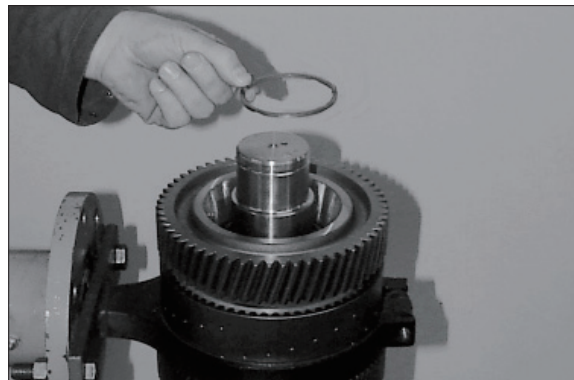

Figure 175

(5) Heat the bearing inner ring (75×41 mm) and locate it until contact.

▲ Use safety gloves.

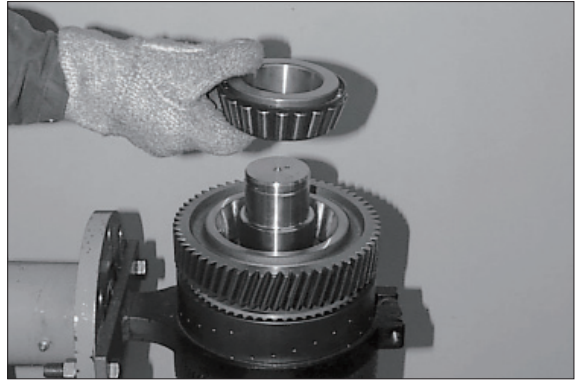

Figure 176

(6) Heat the bearing inner ring (clutch bearing) and locate it until contact.

▲ Use safety gloves.

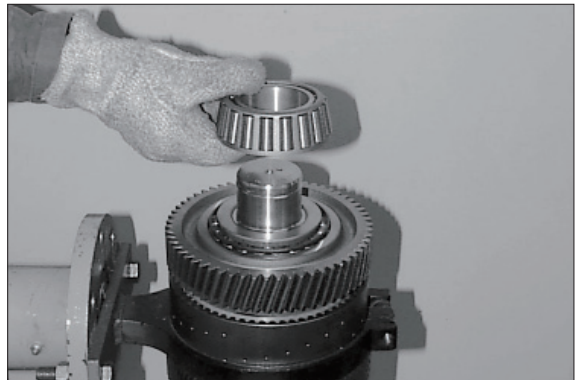

Figure 177

Disc Components K2

※ Below sketch or table shows the standard version as to the installation position of the single components. Obligatory is the respective spare parts list.

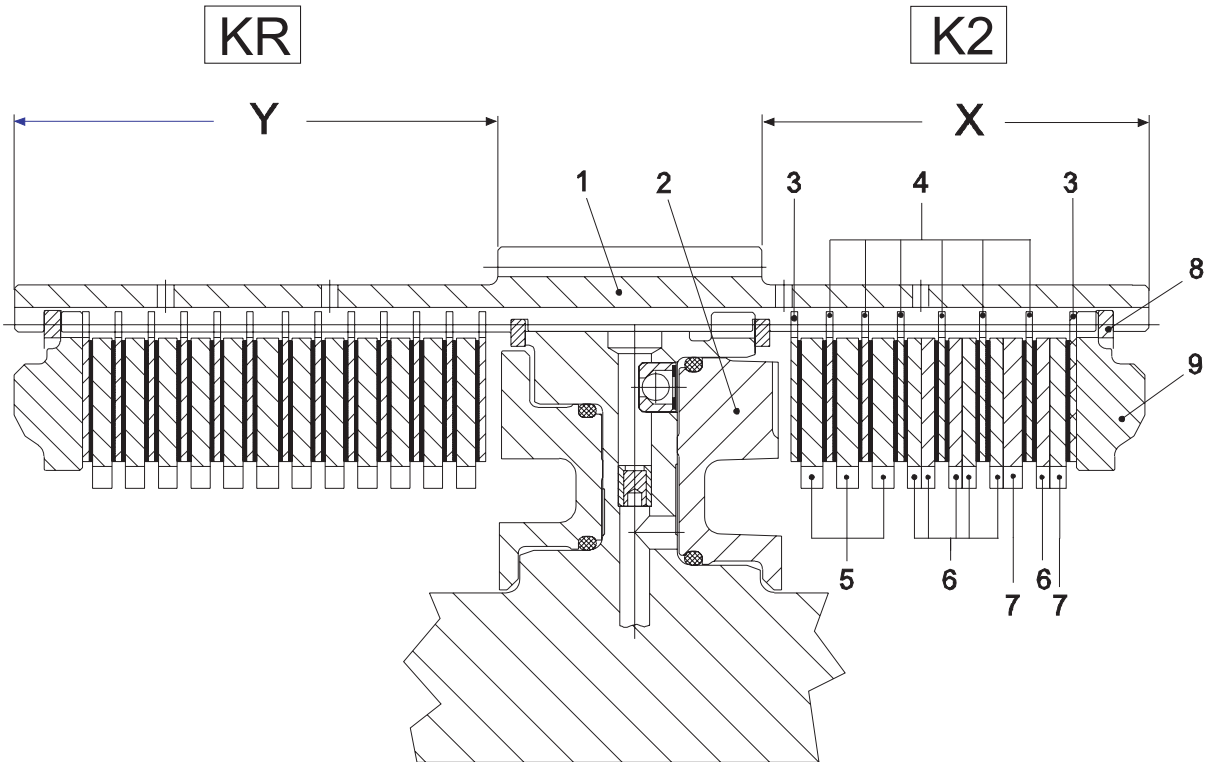

Figure 178

Position	Description	Quantity	s (mm)	Remarks
1	Disc carrier	1		
2	Piston	1		
3	Outer clutch disc	2	1.85	Coated on one side
4	Outer clutch disc	6	2.5	Coated on both sides
5	Inner clutch disc	3	4.0	
6	Inner clutch disc	6	2.5	
7	Inner clutch disc	2	2.5~4.0	Optional
8	Snap ring	1	2.10~3.10	Optional
9	End shim	1		
Number of friction surfaces : 14				
Disc clearance : 2.2 ~ 2.4 mm				

※ Install the outer clutch discs position 3 with uncoated side showing to the piston and end shim respectively. The respective clutch side can be seen on the length of the disc carrier, see sketch.

K2 Dimension X (short disc carrier side)

KR Dimension Y (long disc carrier side)

Check disc clearance $K2=2.2\sim 2.4$ mm
(figure 179~181)

※ In order to ensure a perfect measuring result, the disc set is first of all to be installed without oil.

(1) Install disc set according to sketch or table
(page 3-120).

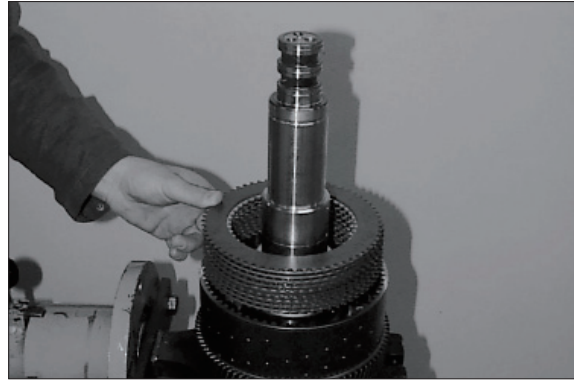

Figure 179

(2) Install the end shim and fasten it by means of the snap ring.

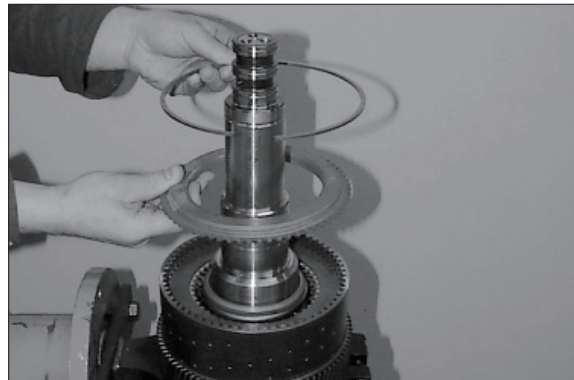

Figure 180

(3) Press on end shim with approximately 100N (10 kg) and set dial indicator to "Zero".

Then press end shim against snap ring (upwards) and read disc clearance on the dial indicator.

※ If the required disc clearance differs, it has to be corrected with the adequate inner clutch disc or/and snap ring, see table/ position 7 and position 8.

Upon setting of disc clearance, remove the disc set, oil the clutch discs and reinstall them.

※ Special tool

Magnetic stand 5870 200 055

Dial indicator 5870 200 057

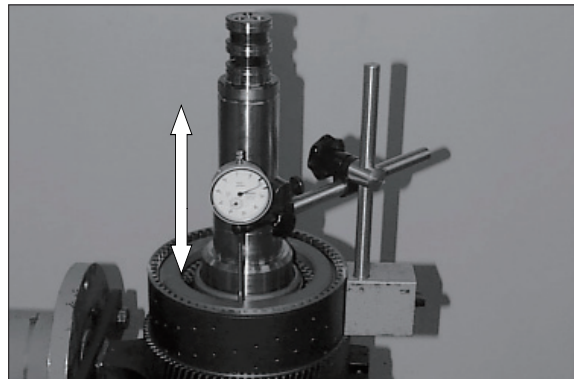

Figure 181

Preassemble and install spur gear K2 (figure182~186) :

- (1) Undercool gear 1 (approx -80°C) and heat gear 2 (approx 120°C). Engage the snap ring (arrow), preload it and join both components by means of hydraulic press until the snap ring engages into the annular groove of gear 2.

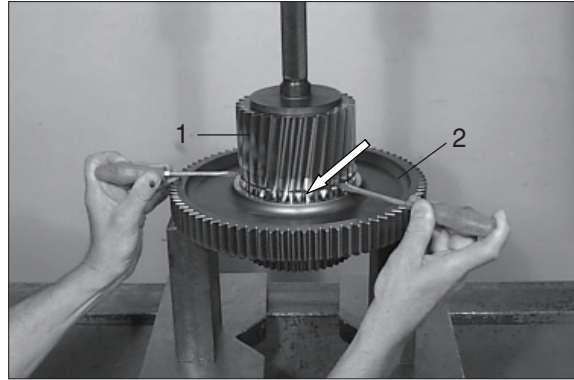

Figure 182

- (2) Opposite figure shows the single components of the spur gear bearing.

- 1 Bearing inner ring
- 2 Spur gear assy
- 3 Bearing inner ring

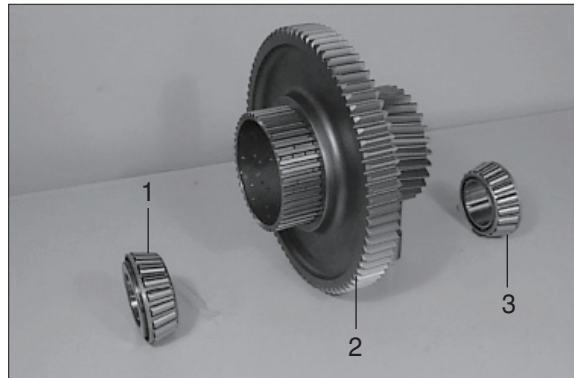

Figure 183

- (3) Heat the bearing inner ring and install it until contact.

▲ Use safety gloves.

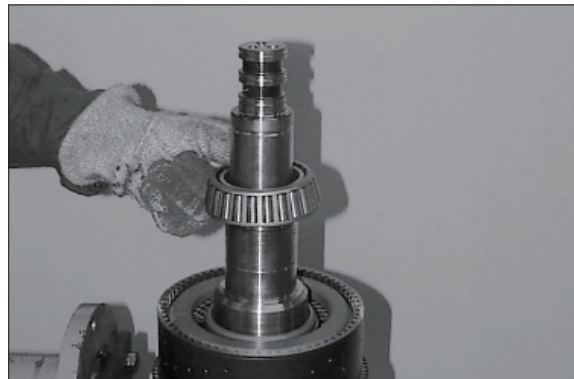

Figure 184

- (4) Assemble the spur gear until all inner clutch discs are located.

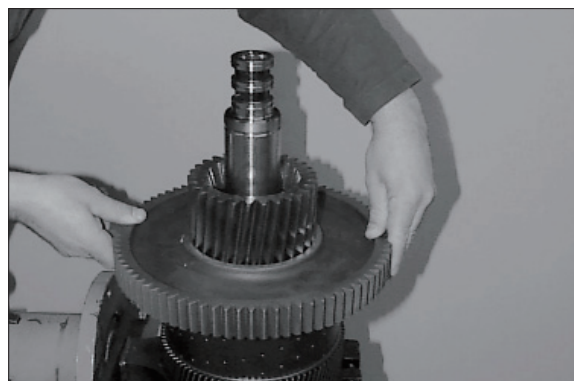

Figure 185

(5) Heat the bearing inner ring (spur gear bearing) and install it until contact.

▲ Use safety gloves.

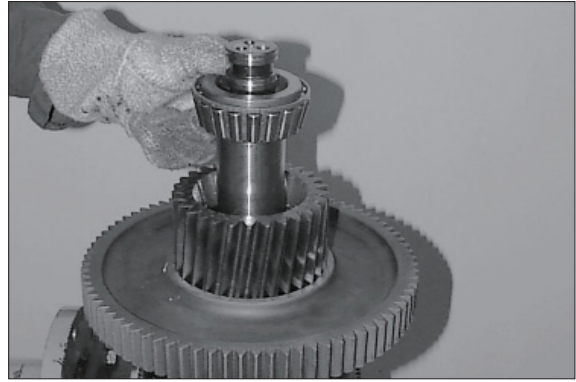

Figure 186

(6) Heat the bearing inner ring (clutch bearing) and locate it until contact.

▲ Use safety gloves.

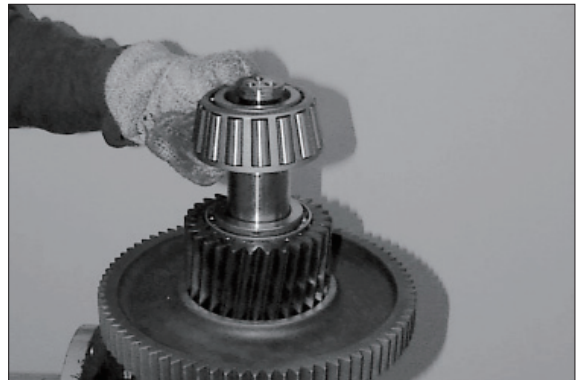

Figure 187

(7) Lift the disc carrier out of the clamping ring.

To ensure the exact locating of the single components, preload the bearing with 100 KN (10t) (figure 188)

**▲ Support on the lower as well as upper bearing inner ring.
Use pressure pieces (S).**

※ Special tool

Pressure piece

5870 506 096

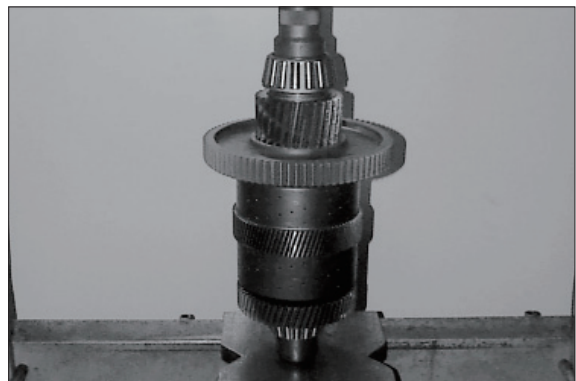

Figure 188

- (8) Lift the disc carrier into the clamping ring and fasten it.

Rotate disc carrier by 90°.

K2-side :

Install the slotted nut.

- ※ Observe installation position of the slotted nut. Chamfer must show to the bearing inner ring, also see sketch/page 3-113. Oil the thread.

· Torque limit : 56.1 kgf · m (406 lbf · ft)

- ※ Special tool

Clamping ring 5870 654 033

Slotted nut wrench 5870 401 099

KR-side :

Install the slotted nut.

- ※ Observe installation position of the slotted nut. Collar (∅ 76 mm) must show to the bearing inner ring, also see sketch/page 3-113. Oil the thread.

· Torque limit : 56.1 kgf · m (406 lbf · ft)

- ※ Special tool

Slotted nut wrench 5870 401 099

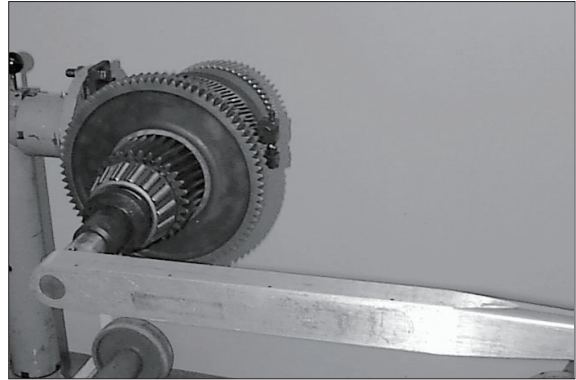

Figure 189



Figure 190

- (9) Check function of the clutches K3 and K4 by means of compressed air (figure 191).

- ※ Closing or opening of the clutches is clearly audible when the single parts have been installed adequately.

Snap-in and lock the rectangular rings (3EA, see arrows).

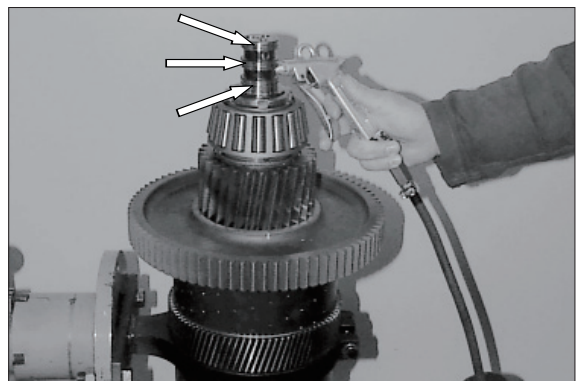

Figure 191

Assembly of the multi-disc clutch KV/K2

The following sketch shows the clutch sectioning

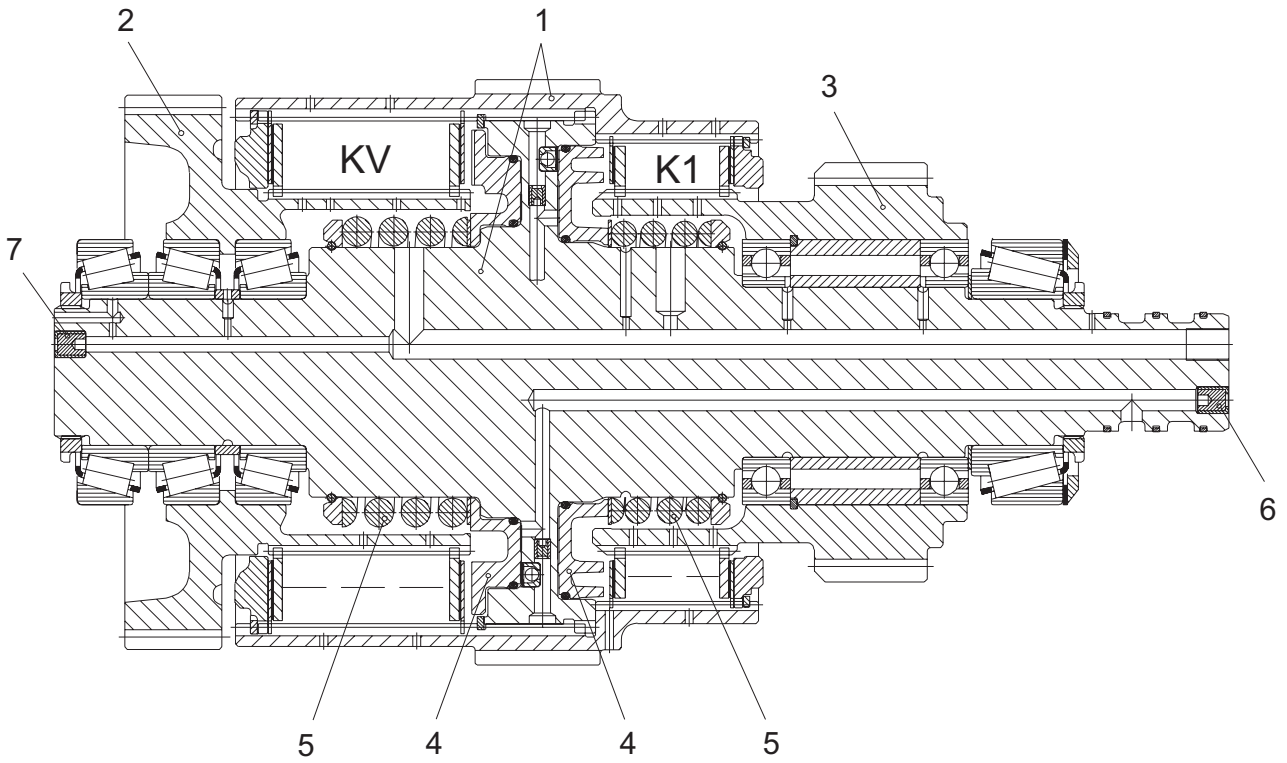

Figure 192

- | | | | | | |
|---|--------------|----|----------------------|---|--------------------|
| 1 | Disc carrier | KV | Multi-disc clutch KV | 5 | Compression spring |
| 2 | Spur gear KV | K1 | Multi-disc clutch K1 | 6 | Plug 2EA |
| 3 | Spur gear K1 | 4 | Piston | 7 | Plug 1EA |

※ Observe the installation position of the single components for the following assembly.

- (1) Lift the disc carrier with the KV-side showing downwards into the clamping ring(S) and fasten it.
Then rotate disc carrier by 180°.

**▲ To install new disc carriers the finished bores have to be sealed with plugs.
Installation position, see arrow, figure193~194.**

※ Special tool

Hand mounting tool 5870 320 014

Ratchet spanner 5870 320 018

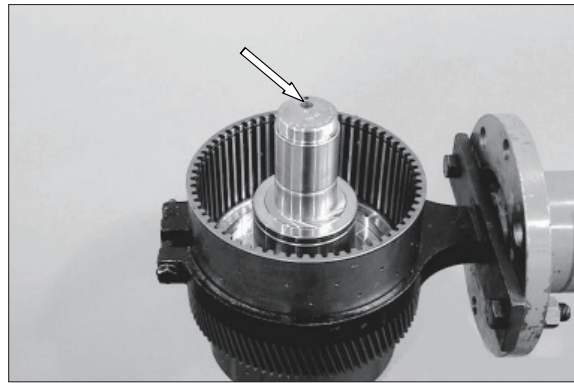

Figure 193

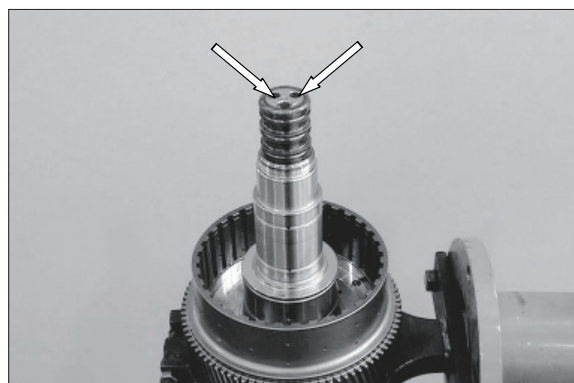

Figure 194

- (2) Flush-mount the drain valve (arrow) with the chamfer showing downwards.

※ Special tool

Inserting tool 5870 320 019

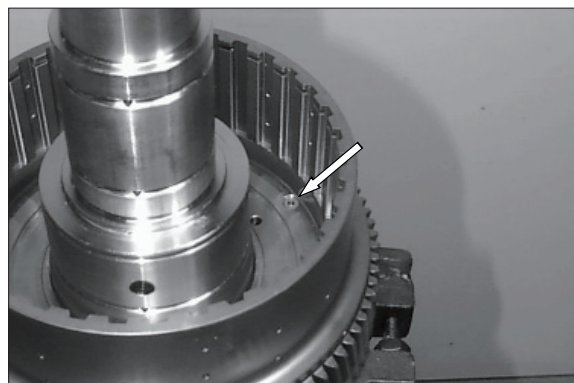

Figure 195

- (3) Put both O-rings scroll-free into the annular grooves of the piston, see arrows.

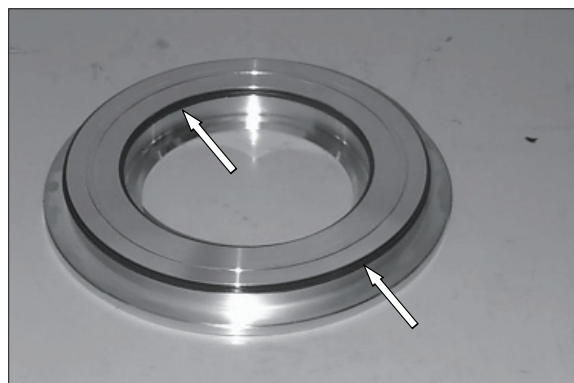

Figure 196

- (4) Oil the O-rings and the piston contact surface.

Install K1 piston equally until contact.

- ※ Observe the installation position of the piston, see figure.

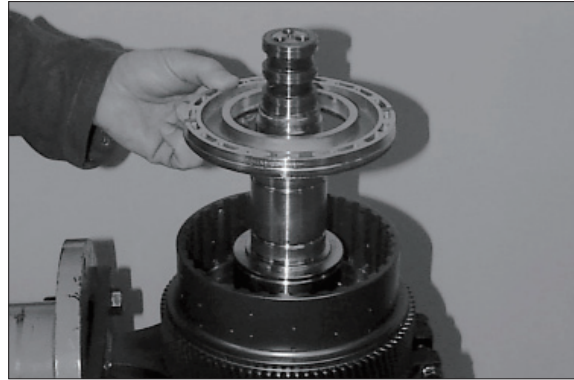

Figure 197

- (5) Install spacer and compression spring.

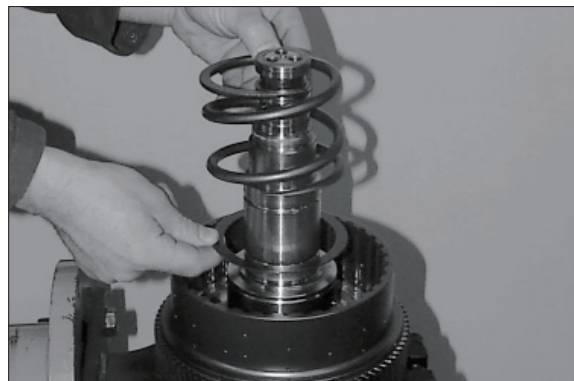

Figure 198

- (6) Place guide ring, with the chamfer (arrow) showing upwards, over the compression spring and install the snap ring.

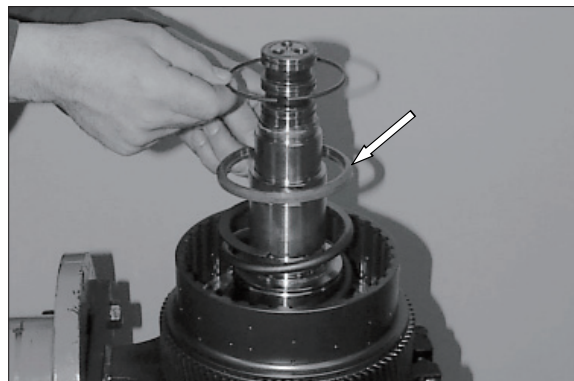

Figure 199

- (7) Lift the disc carrier out of the clamping ring. Preload the compression spring by means of fixture and engage the snap ring into the annular groove of the disc carrier (arrow), see figure 200.

Install the drain valve, piston and compression spring on the opposite side (clutch KV) analogously.

Then lift the disc carrier with the KV-side showing downwards into the clamping ring and fasten it.

Rotate disc carrier by 180°.

- ※ Special tool

Pressure piece 5870 345 072

Clamping fixture 5870 654 036



Figure 200

Disc Components KV

※ Below sketch or table shows the standard version as to the installation position of the single components. Obligatory is the respective spare parts list.

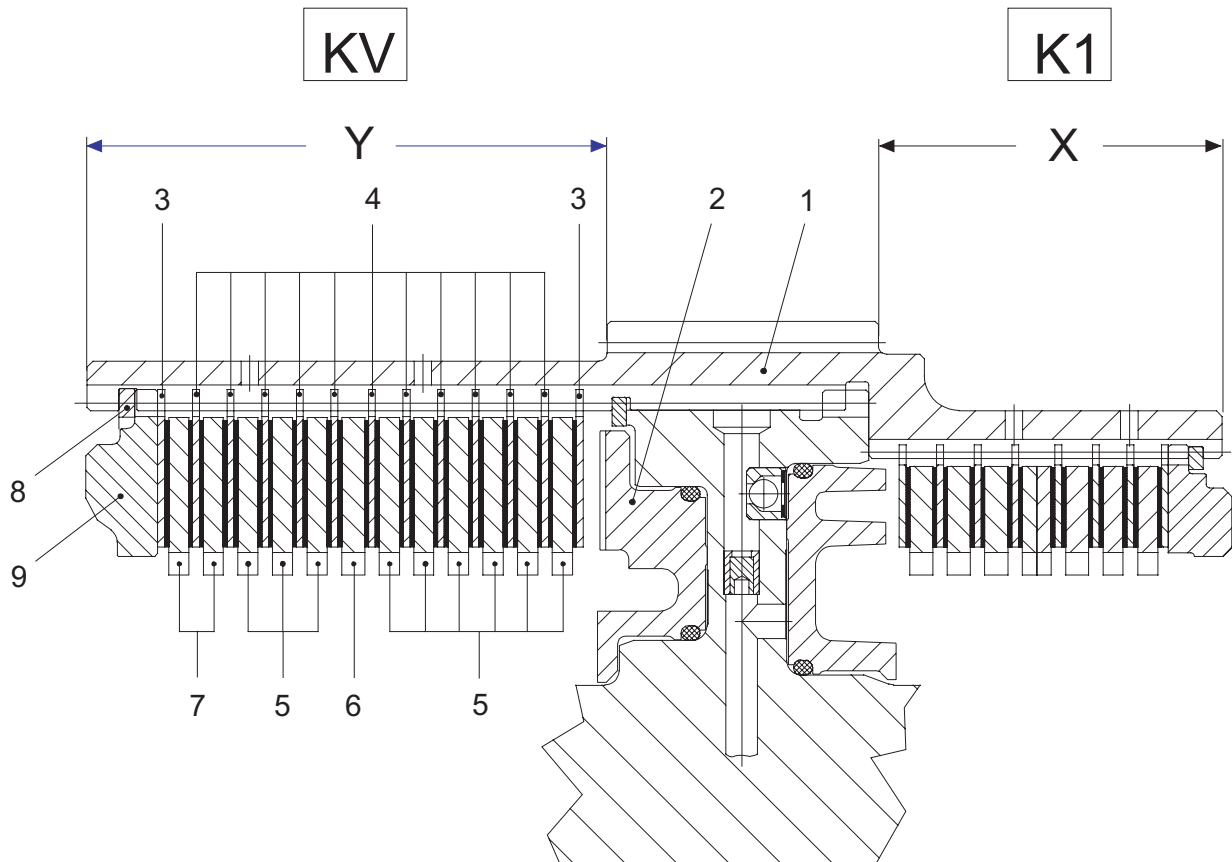

Figure 201

Position	Description	Quantity	s (mm)	Remarks
1	Disc carrier	1		
2	Piston	1		
3	Outer clutch disc	2	1.85	Coated on one side
4	Outer clutch disc	11	2.5	Coated on both sides
5	Inner clutch disc	9	3.5	
6	Inner clutch disc	1	4.0	
7	Inner clutch disc	2	2.5~4.0	Optional
8	Snap ring	1	2.10~3.10	Optional
9	End shim	1		
Number of friction surfaces : 24				
Disc clearance : 2.8 ~ 3.0 mm				

※ Install the outer clutch discs position 3 with uncoated side showing to the piston and end shim respectively. The respective clutch side can be seen on the length and \varnothing of the disc carrier respectively, see sketch.

KV Dimension Y (long disc carrier side and large \varnothing respectively)

K1 Dimension X (short disc carrier side and small \varnothing respectively)

Check disc clearance KV=2.8~3.0 mm
(figure 202~204)

※ In order to ensure a perfect measuring result, the disc set is first of all to be installed without oil.

(1) Install disc set according to sketch or table (page 3-128).

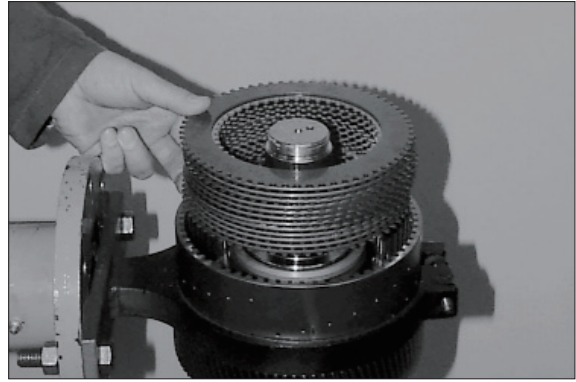

Figure 202

(2) Install the end shim and fasten it by means of the snap ring.

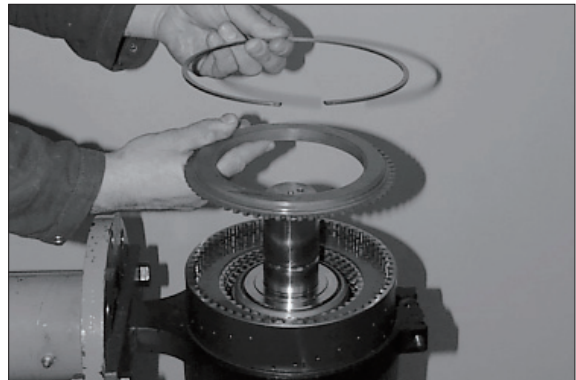

Figure 203

(3) Press on end shim with approximately 100N (10 kg) and set dial indicator to "Zero".

Then press end shim against snap ring (upwards) and read disc clearance on the dial indicator.

※ If the required disc clearance differs, it has to be corrected with the adequate inner clutch disc or/and snap ring, see table/ position 7 and position 8.

Upon setting of disc clearance, remove the disc set, oil the clutch discs and reinstall them.

※ Special tool

Magnetic stand 5870 200 055

Dial indicator 5870 200 057

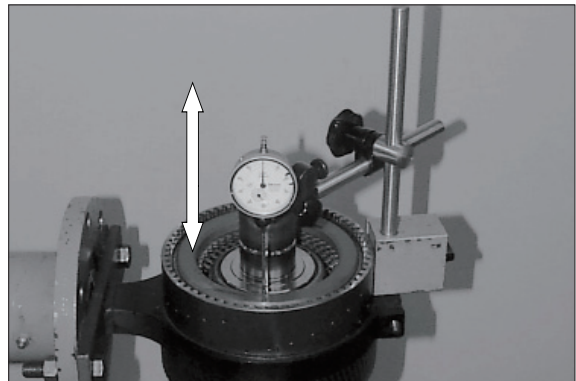

Figure 204

Preassemble and install spur gear KV
(figure 205~209) :

(1) Opposite figure shows the single components of spur gear KV.

- 1 Bearing inner ring
- 2 Bearing outer ring
- 3 Ring
- 4 Spur gear

Install both bearing outer rings (2) until contact.

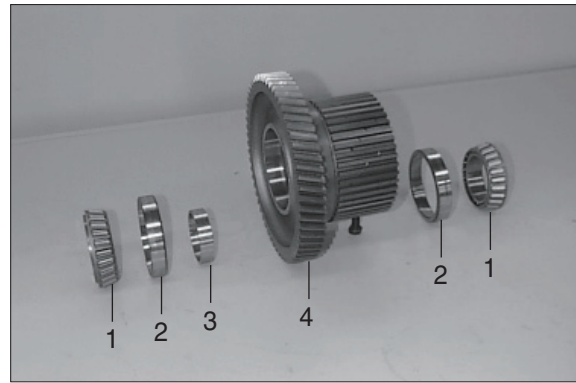

Figure 205

(2) Heat the bearing inner ring and install it until contact.

▲ Use safety gloves.

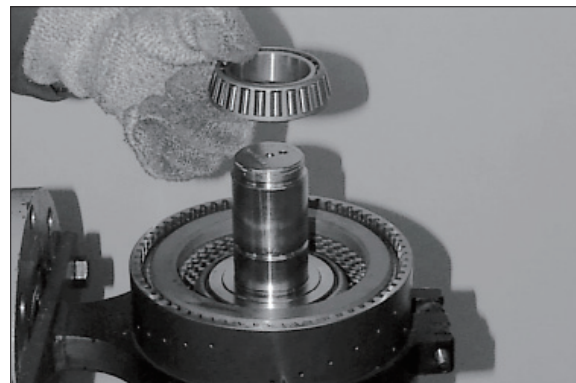

Figure 206

(3) Install the ring.

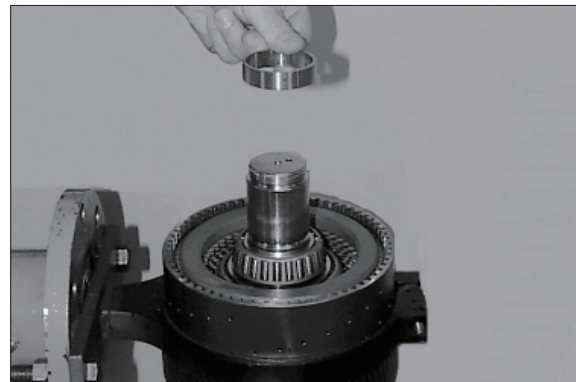

Figure 207

(4) Assemble the spur gear until all inner clutch discs are located.

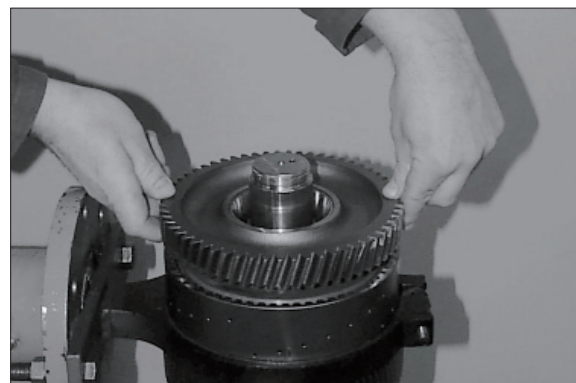

Figure 208

(5) Heat the bearing inner ring (spur gear bearing) and locate it until contact.

▲ Use safety gloves.

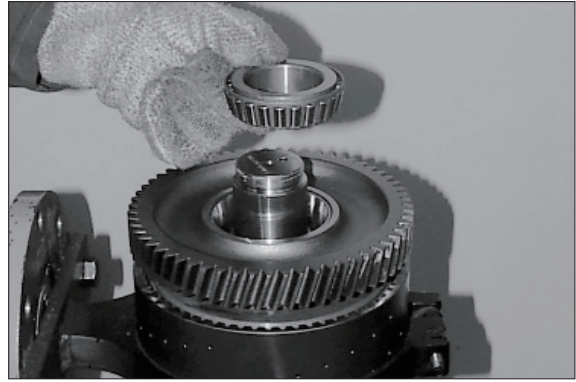

Figure 209

(6) Heat the bearing inner ring (clutch bearing) and locate it until contact.

▲ Use safety gloves.

Rotate disc carrier by 180°.

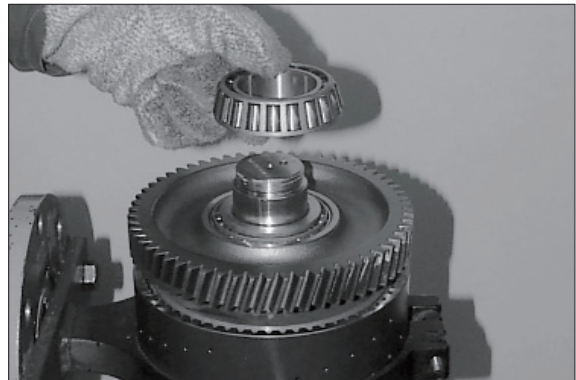

Figure 210

Disc Components K1

※ Below sketch or table shows the standard version as to the installation position of the single components. Obligatory is the respective spare parts list.

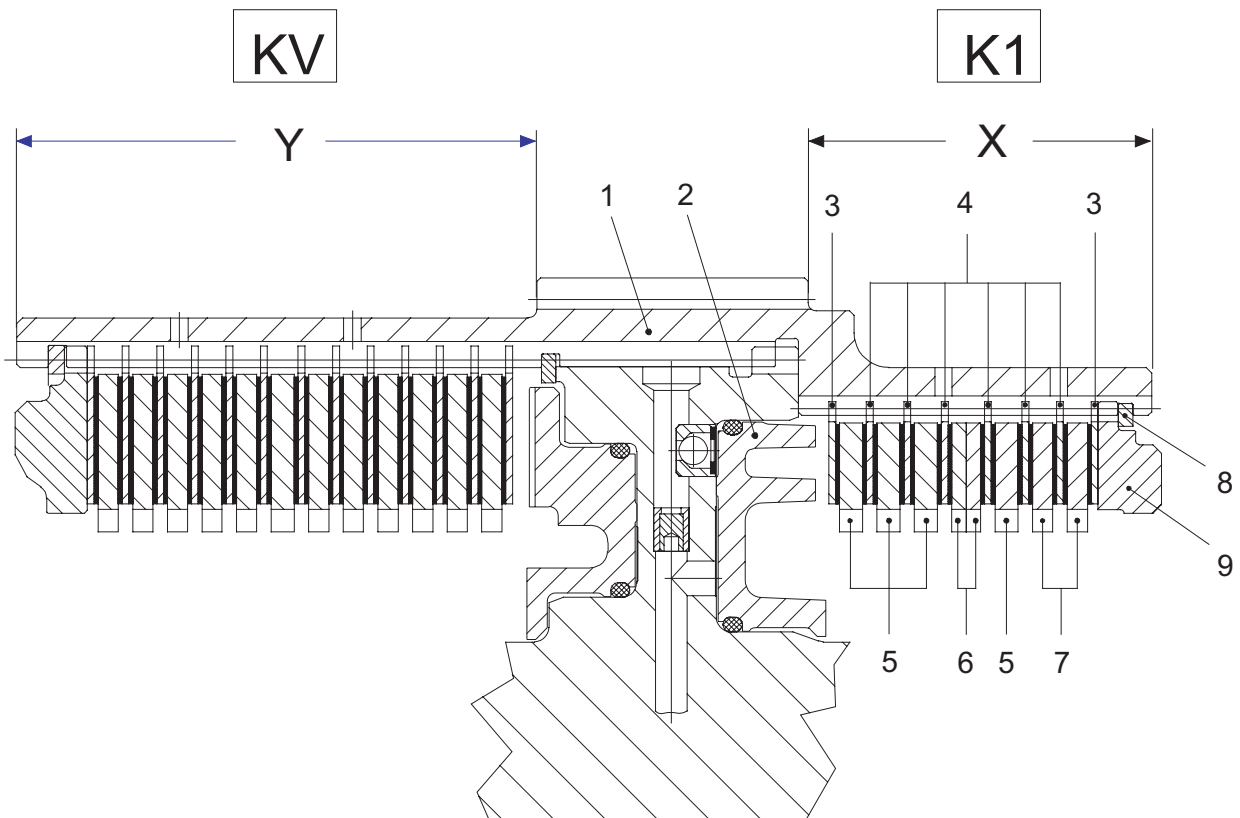

Figure 211

Position	Description	Quantity	s (mm)	Remarks
1	Disc carrier	1		
2	Piston	1		
3	Outer clutch disc	2	1.85	Coated on one side
4	Outer clutch disc	6	2.5	Coated on both sides
5	Inner clutch disc	4	4.0	
6	Inner clutch disc	2	2.5	
7	Inner clutch disc	2	2.5~4.0	Optional
8	Snap ring	1	2.1~2.5	Optional
9	End shim	1		
Number of friction surfaces : 14				
Disc clearance : 2.2 ~ 2.4 mm				

※ Install the outer clutch discs position 3 with uncoated side showing to the piston and end shim respectively. The respective clutch side can be seen on the length and \varnothing of the disc carrier respectively, see sketch.

K1 Dimension X (short disc carrier side and small \varnothing respectively)

KV Dimension Y (long disc carrier side and large \varnothing respectively)

Check disc clearance KV=2.2~2.4 mm
(figure 212~214)

※ In order to ensure a perfect measuring result, the disc set is first of all to be installed without oil.

(1) Install disc set according to sketch or table (page 3-132).

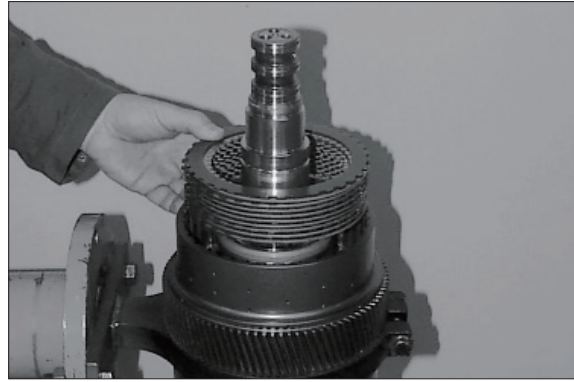

Figure 212

(2) Install the end shim and fasten it by means of the snap ring.

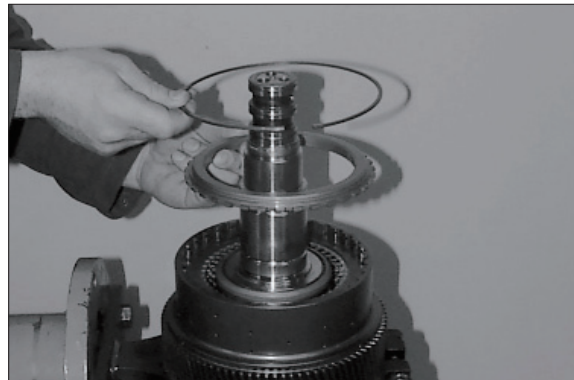

Figure 213

(3) Press on end shim with approximately 100N (10 kg) and set dial indicator to "Zero".

Then press end shim against snap ring (upwards) and read disc clearance on the dial indicator.

※ If the required disc clearance differs, it has to be corrected with the adequate inner clutch disc or/and snap ring, see table/ position 7 and position 8.

Upon setting of disc clearance, remove the disc set, oil the clutch discs and reinstall them.

※ Special tool

Magnetic stand 5870 200 055

Dial indicator 5870 200 057

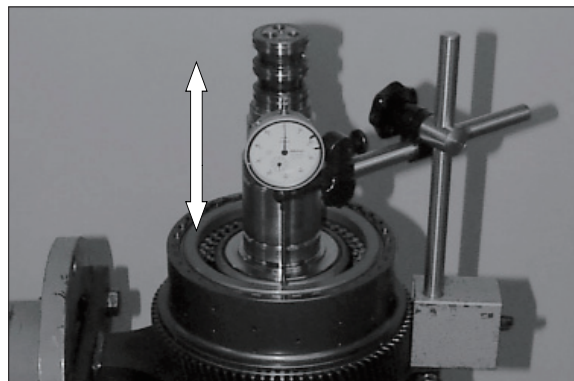

Figure 214

Preassemble and install spur gear K1
(figure 215~222) :

(1) Opposite figure shows the single components of spur gear K1.

- 1 Ball bearing (assy)
- 2 Snap ring
- 3 Spur gear

※ Prior to installation of the single components, align the disc set by means of the spur gear radially and center it, see figure 216.

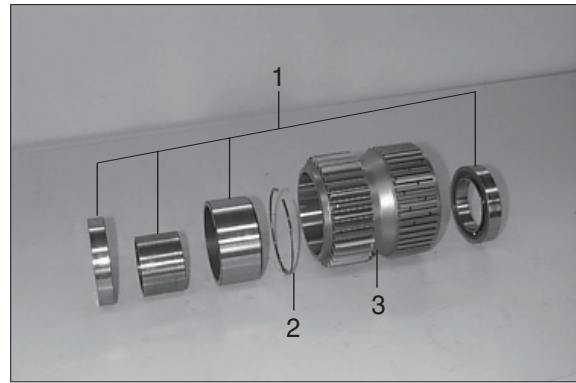

Figure 215

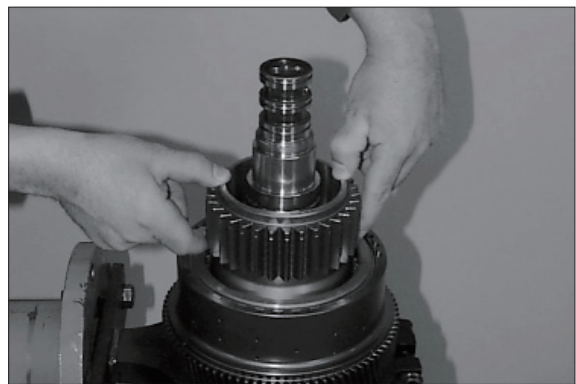

Figure 216

(2) Install the ring.

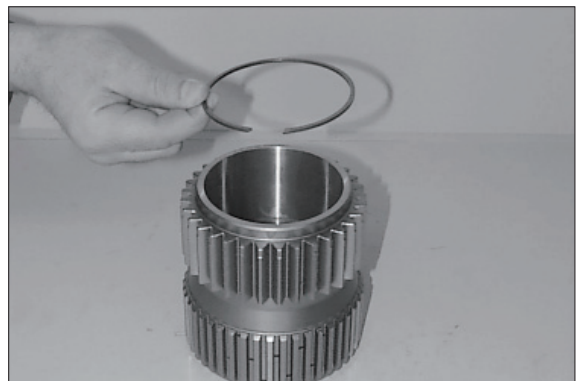

Figure 217

(3) Install the bush with collar (arrow) on face end showing to the snap ring.

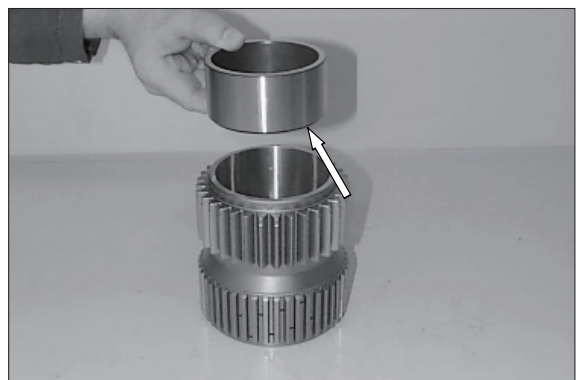

Figure 218

(4) Press in the ball bearing until contact.

- ※ Install the ball bearing with the lubricating groove (arrow) showing downwards. Put the press-in tool only to the bearing outer ring.

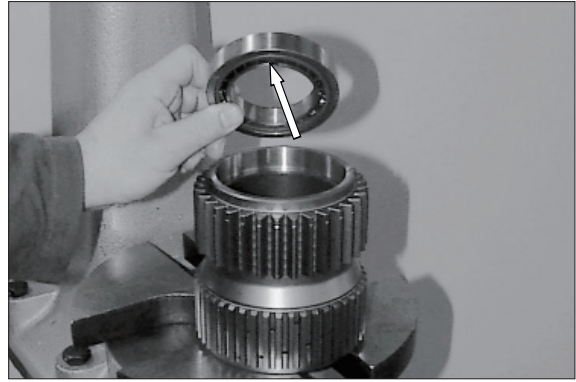

Figure 219

(5) Heat the second ball bearing and install it until contact.

- ※ Lubricating groove (arrow), must show upwards.

▲ Use safety gloves.



Figure 220

(6) Assemble the bush.

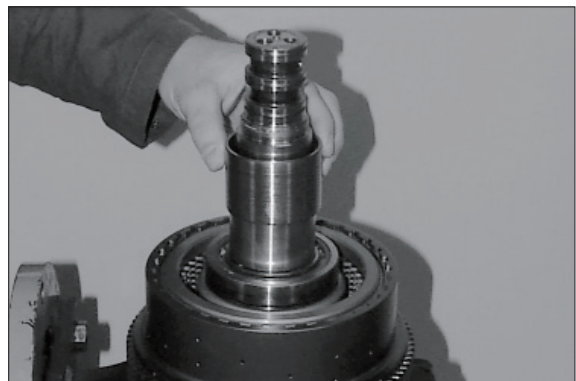

Figure 221

(7) Heat the spur gear to approximately 120°C and assemble it until all inner clutch discs are located.

▲ Use safety gloves.

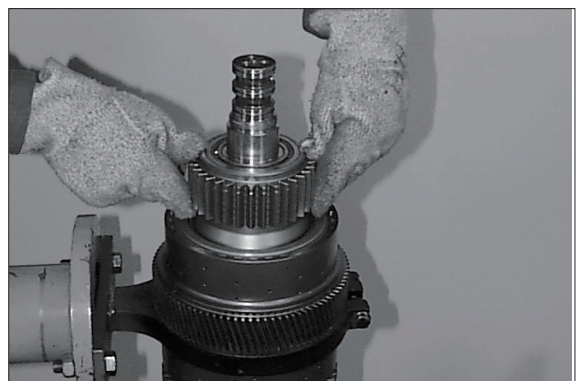

Figure 222

(8) Install shim $s = 1.20 \text{ mm}$

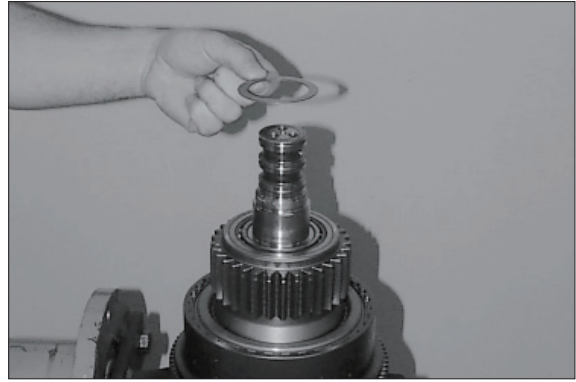

Figure 223

(9) Heat the bearing inner ring and install it until contact.

▲ Use safety gloves.



Figure 224

(10) Lift the disc carrier out of the clamping ring (S). To ensure the exact locating of the single components, preload the bearing with 100kN (10 t) (figure 225).

**▲ Support on the lower as well as upper bearing inner ring.
Use pressure pieces (S).**

※ Special tool

Pressure pieces

5870 506 096

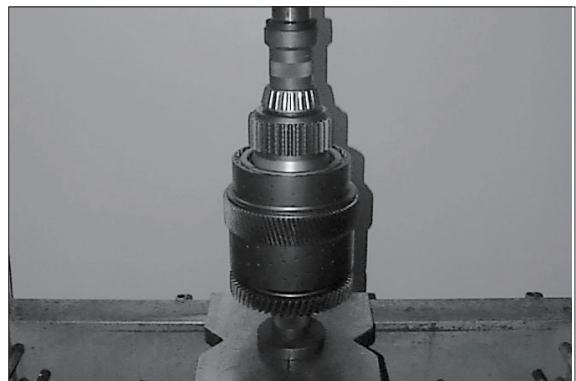

Figure 225

(11) Lift the disc carrier into the clamping ring (S). Rotate disc carrier by 90°. Install the slotted nut.

- ※ Observe installation position of the slotted nut. Collar (\varnothing 60 mm) must show to the taper roller bearing also see sketch/page 3-125. Oil the thread.

- Torque limit : 56.1 kgf · m (406 lbf · ft)

- ※ Special tool

Slotted nut wrench 5870 401 118

Slotted nut wrench 5870 401 099

Install the opposite slotted nut (KV-side) analogously.

- ※ Special tool

Slotted nut wrench 5870 401 118

Slotted nut wrench 5870 401 115

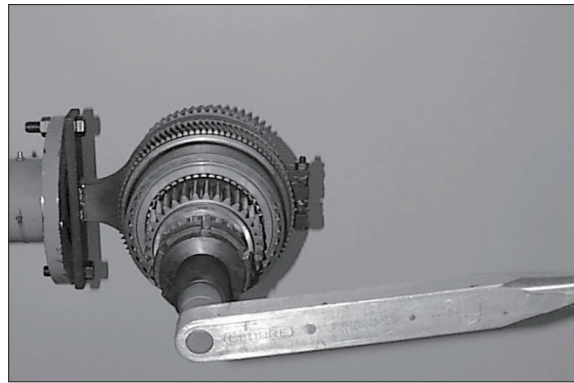

Figure 226

(12) Check function of the clutches KV and K1 by means of compressed air.

- ※ Closing or opening of the clutches is clearly audible when the single parts have been installed adequately.



Figure 227

(13) Snap-in and lock the rectangular rings (3EA, see arrows).



Figure 228

Installation of layshaft gear, multi-disc clutches and output gear

(1) Opposite figure shows the single components of the layshaft gear bearing.

- 1 Bearing inner ring (2EA)
- 2 Ring
- 3 Layshaft gear

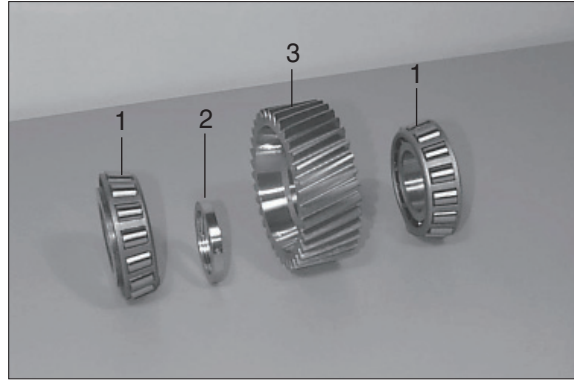

Figure 229

(2) Position layshaft gear (assy) in the housing.

※ Only when the clutches are installed, the idler shaft can be mounted.

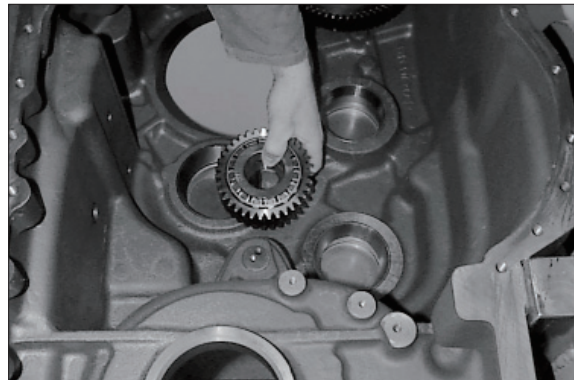

Figure 230

(3) Insert the bearing outer rings KV/K1, KR/K2 and K3/K4 into the housing bores until contact, see arrows.

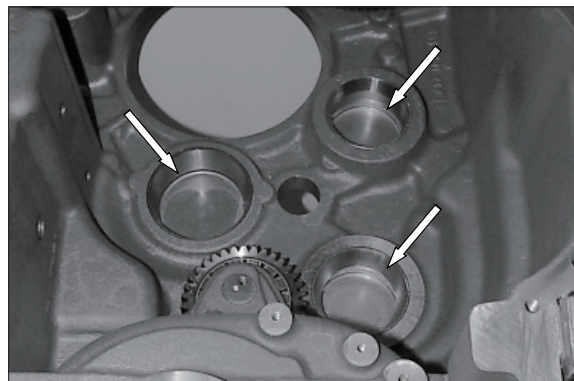

Figure 231

(4) Position clutch KV/K1 by means of lifting tackle.

※ Special tool
Eyebolts assortment 5870 204 002

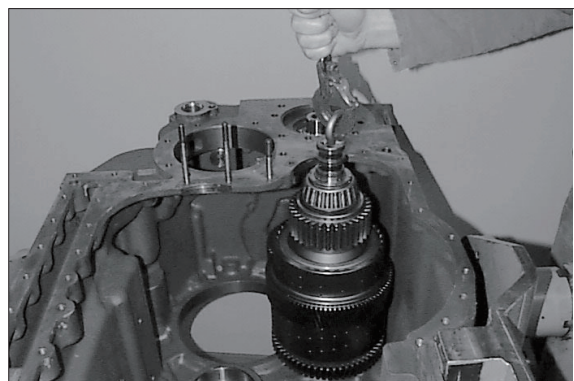

Figure 232

(5) Position clutch KR/K2.

- ※ Special tool
Eyebolts assortment 5870 204 002

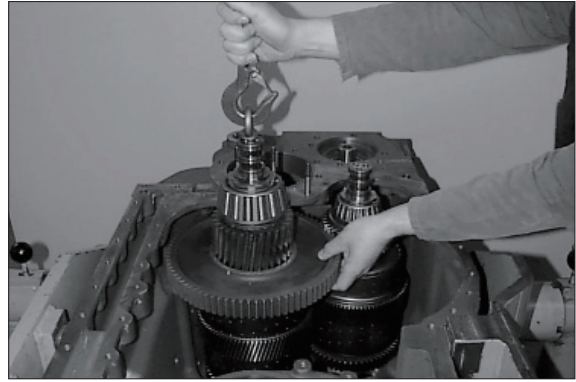

Figure 233

(6) Check the installation position of the layshaft gear (arrow) once again and correct it, if required.

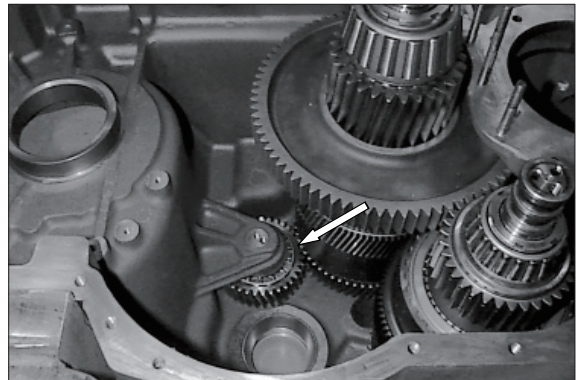

Figure 234

(7) Fasten the spur gear K3 by means of fixture and eyebolt (arrow) axially.

- ※ Spur gear fixing prevents the clutch discs from dislocating when the clutch is lifted in.
- ※ Special tool
Assembly fixture 5870 345 033
Eyebolt 5870 204 066



Figure 235

(8) Lift the clutch KR/K2 slightly, move it in direction of the arrow and position clutch K3/K4.

Then remove the fixture (figure 235) again.

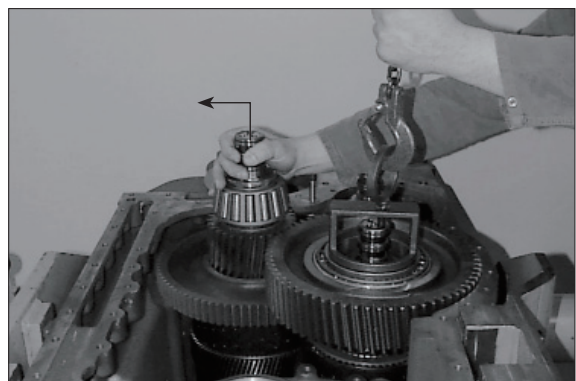

Figure 236

(9) Insert the bearing outer ring into the housing bore until contact.

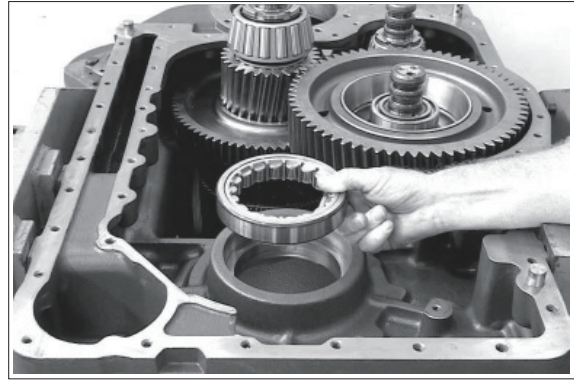

Figure 237

(10) Heat the bearing inner ring and install it until contact.

▲ Use safety gloves.

※ Observe installation position-collar (arrow) shows to the spur gear. Install the bearing inner ring after cooling down subsequently (press).



Figure 238

(11) Position the oil baffle.

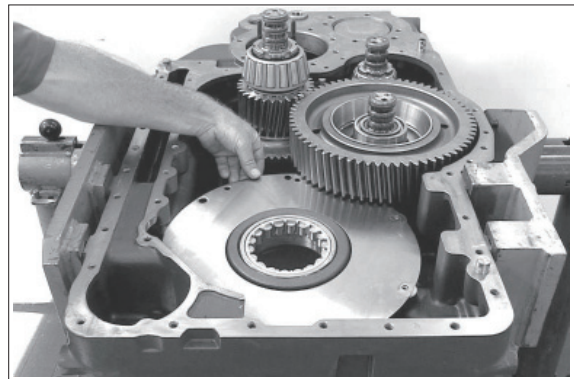

Figure 239

(12) Install the output gear by means of lifting tackle.

※ Special tool
Stop washer 5870 100 054
Eyebolts assortment 5870 204 002

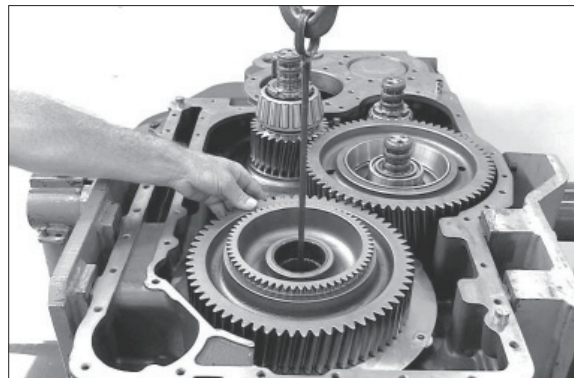

Figure 240

(13) Position upper oil baffle and fasten both plates by means of hexagon screws (4EA).

※ Install washers.

Secure hexagon screws with loctite (type No.243).

· Torque limit : 2.35 kgf · m (16.7 lbf · ft)

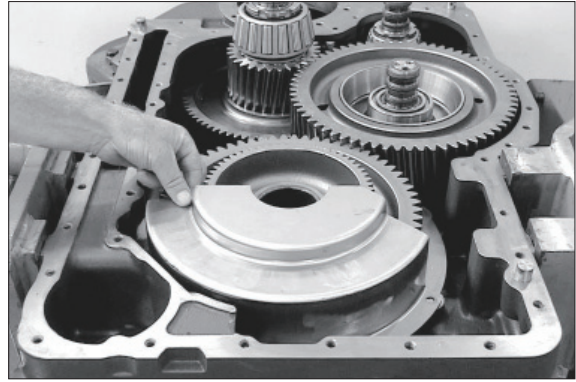

Figure 241

Preassembly and mounting of the housing cover

Note to figure 242 and 243 :

Depending on the transmission version, differences as regards the single components and their installation position are possible.

Obligatory is the respective parts list.

(1) Install the sealing cover (arrow).

※ Wet the sealing surface with Loctite (type No.262).

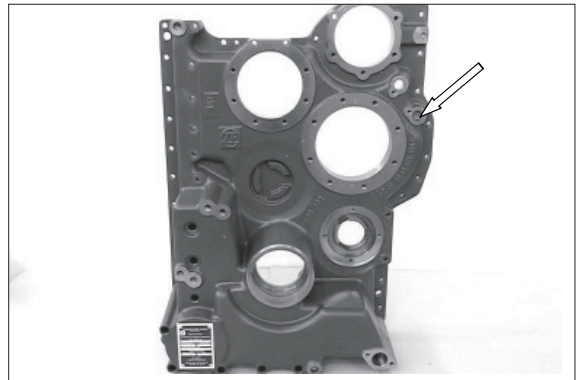

Figure 242

(2) Insert the O-ring into the annular groove of the cover and fasten the cover by means of hexagon screws.

※ Wet the thread of the hexagon screws with loctite (type No.574). Observe the installation position of the cover, see figure.

· Torque limit : 2.35 kgf · m (16.7 lbf · ft)

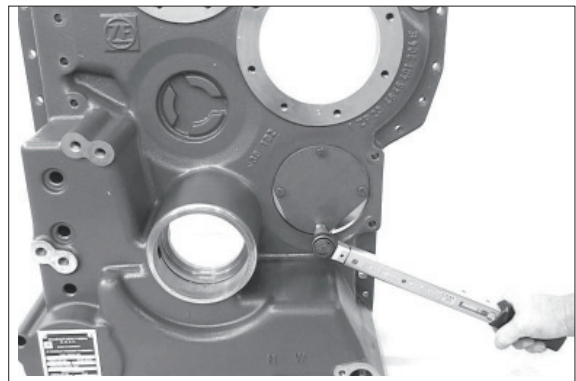

Figure 243

(3) Wet the mounting face with sealing compound (loctite, type No.574).

By means of the lifting tackle place the housing cover on the transmission housing until contact.

※ Special tool

Lifting tackle

5870 281 055

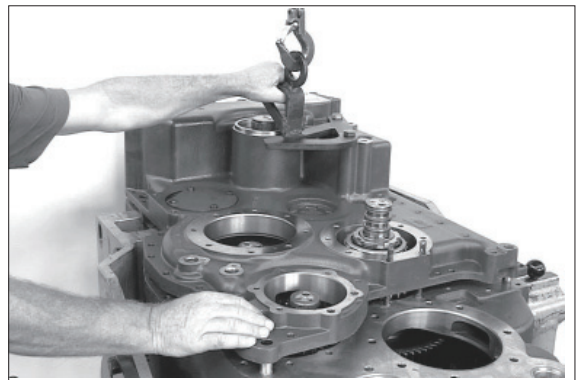

Figure 244

- (4) Install both cylindrical pins (arrow 1 and 2) and the slotted pin (arrow 3).
Then fasten the housing cover by means of hexagon and cap screws.

· Torque limit M10/8.8 :

4.69 kgf · m (33.9 lbf · ft)

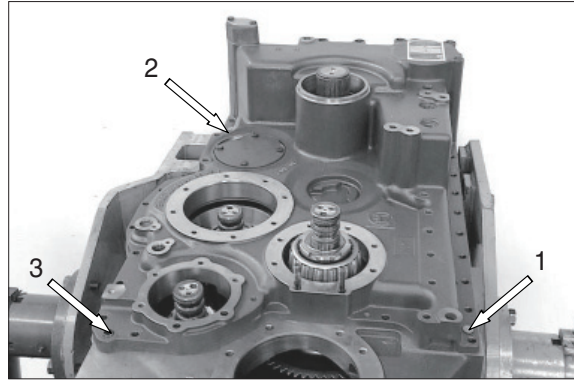

Figure 245

Adjust the bearing preload of clutch K4/K3 = 0.0~0.05 mm (figure 248~250)

- ※ For installation of a new bearing cover, both finished bores have to be sealed by means of a plug.
Finished bores are located opposite (180°) to each other, also see arrow/figure 246 and 247.

- 1 Bearing cover-K4/K3
- 2 Plug (konig)
- (S) Special tool

- ※ Special tool
- | | |
|--------------------|--------------|
| Hand mounting tool | 5870 320 014 |
| Ratchet spanner | 5870 320 018 |

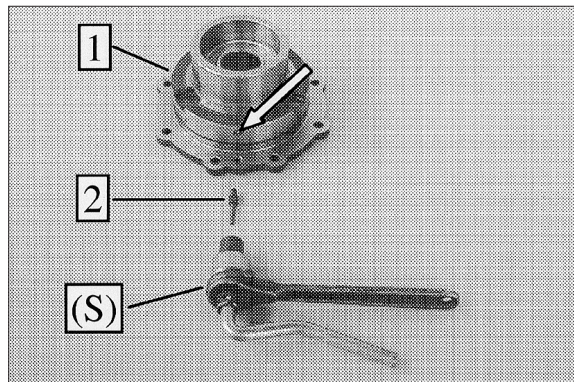

Figure 246

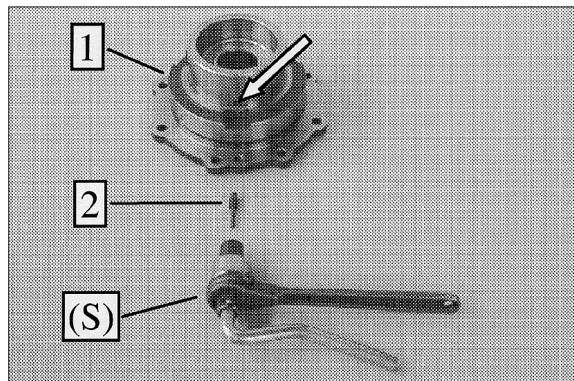

Figure 247

Housing dimension :

- (1) Press on equally the bearing inner ring and determine Dimension I, from the mounting face to the bearing inner ring.

Dimension I e.g 43.65 mm

- ※ Take several measuring points and determine the mean value.

Then remove the bearing inner ring again.

- ※ Special tool

Measuring shaft 5870 200 022

Digital depth gauge 5870 200 072

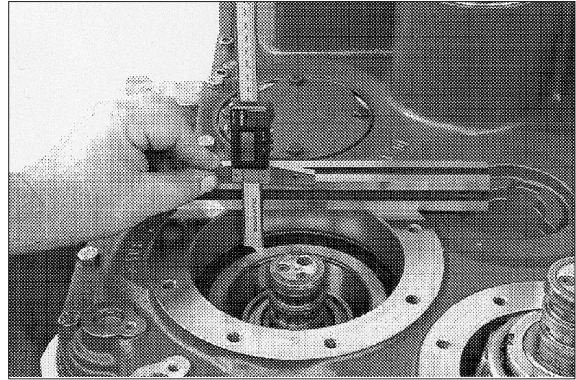

Figure 248

Cover dimension :

- (2) Determine Dimension II, from the mounting face until contact/bearing inner ring.

Dimension II e.g 42.12 mm

- ※ Special tool

Straightedge 5870 200 022

Gauge blocks 5870 200 067

Digital depth gauge 5870 200 072

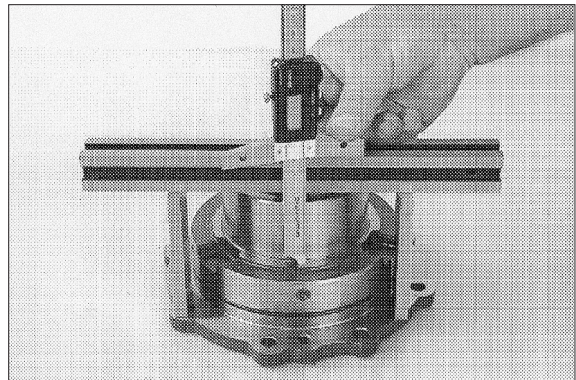

Figure 249

Example :

Dimension I 43.65 mm

Dimension II - 42.12 mm

Difference = 1.53 mm

Bearing preload e.g. + 0.02 mm

Resulting shim(s) s = 1.55 mm

- (3) Put on the shim.

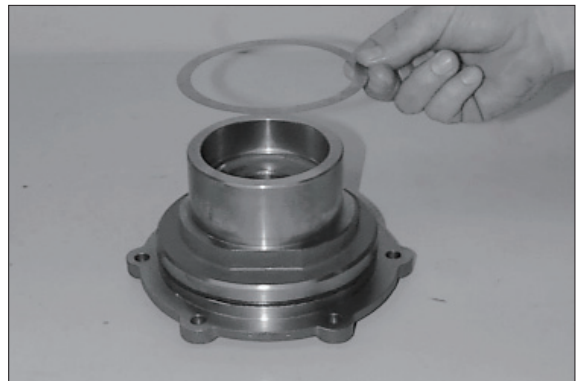

Figure 250

- (4) Heat the bearing inner ring and place it until contact.

- ▲ Use safety gloves.

- ※ Install the bearing inner ring after cooling down subsequently (press).



Figure 251

- (5) Grease the rectangular rings (3EA, arrows) and centrally align them.

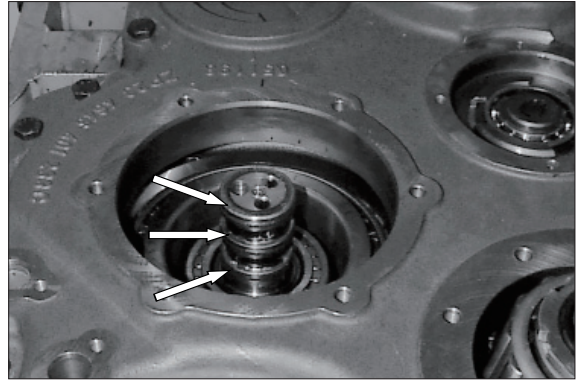

Figure 252

- (6) Install the O-ring (arrow) and grease it.
Heat the inner diameter of the bearing cover (bearing seat).

- ※ Special tool
Hot-air blower 230V 5870 221 500
Hot-air blower 115V 5870 221 501



Figure 253

- (7) Install two adjusting screws.
Assemble the bearing cover and tighten it equally until contact by means of hexagon screws.

- Torque limit (M10/8.8) :
4.69 kgf · m (33.9 lbf · ft)

- ※ Observe the radial installation position.
※ Special tool
Adjusting screws 5870 204 007

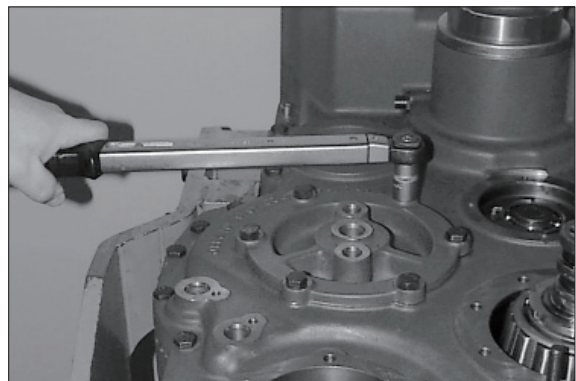

Figure 254

- (8) Check the function of both clutches by means of compressed air.

- ※ In case of a decisive pressure loss, the possible cause might be the breakage of one or several rectangular rings (see arrow , figure 252).
Replace the rectangular rings, if required.

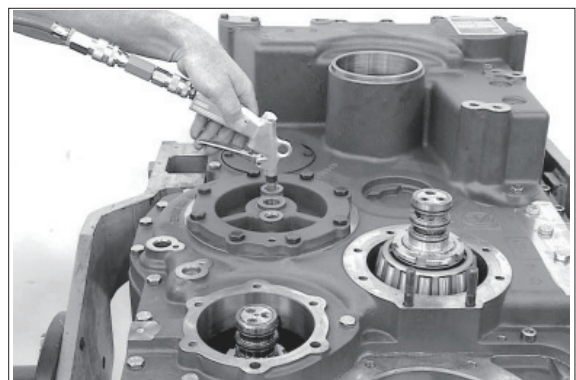

Figure 255

**Adjust the bearing preload of clutch KR/K2
= 0.0~0.05 mm (figure 258~262)**

※ For installation of a new bearing cover, both finished bores have to be sealed by means of a plug.

Finished bores are located opposite (18°) to each other, also see arrow/Figure 256 and 257.

- 1 Bearing cover-KR/K2
- 2 Plug
- (S) Special tool

※ Special tool

- Hand mounting tool 5870 320 014
- Ratchet spanner 5870 320 018

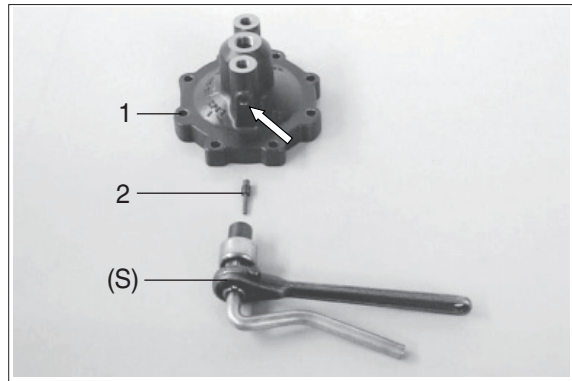

Figure 256

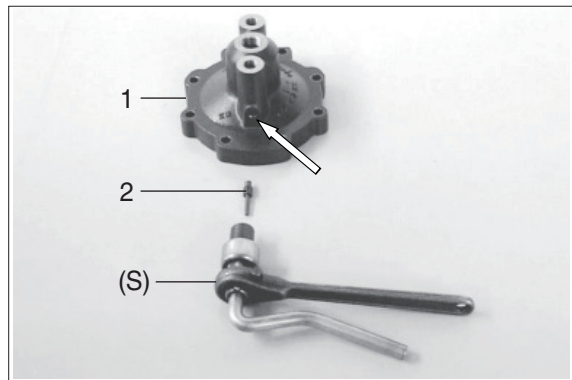

Figure 257

(1) Install both studs (arrows).

※ Wet the thread with loctite (type No. 243).

- Torque limit (M10) :
1.33 kgf · m (9.59 lbf · ft)

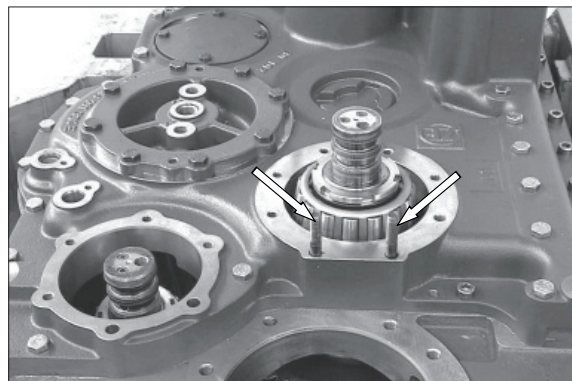

Figure 258

(2) Install the bearing outer ring until contact.

※ Pay attention to exact contact.

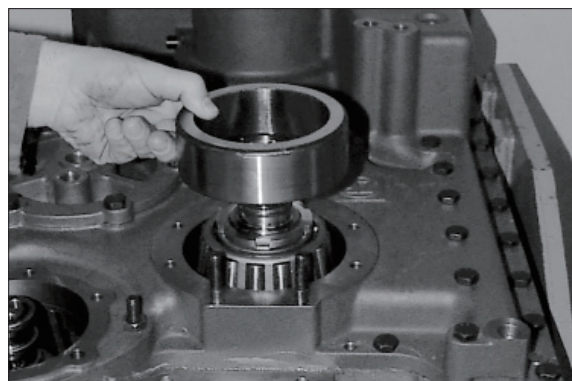

Figure 259

Housing dimension :

- (3) Determine Dimension I, from the bearing outer ring to the mounting face.

Dimension I e.g 16.13 mm

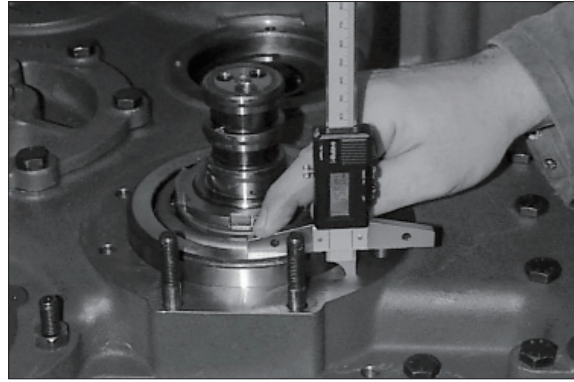

Figure 260

Cover dimension :

- (4) Determine Dimension II, from the contact/bearing outer ring to the mounting face.

Dimension II e.g 17.75 mm

※ Special tool

Digital depth gauge 5870 200 072

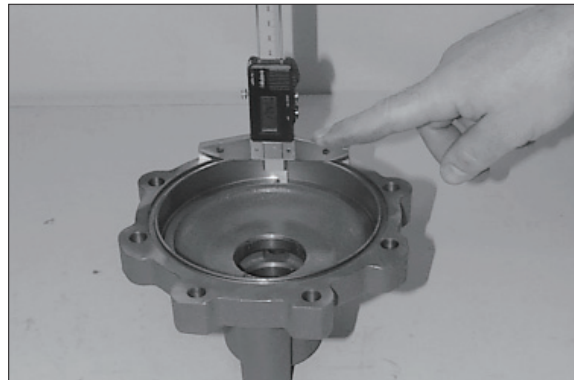

Figure 261

Example :

Dimension II 17.75 mm

Dimension I - 16.13 mm

Difference = 1.62 mm

Bearing preload e.g. + 0.03 mm

Resulting shim (s) s = 1.65 mm

- (5) Fix the shim with assembly grease into the cover. Install the O-ring (arrow).

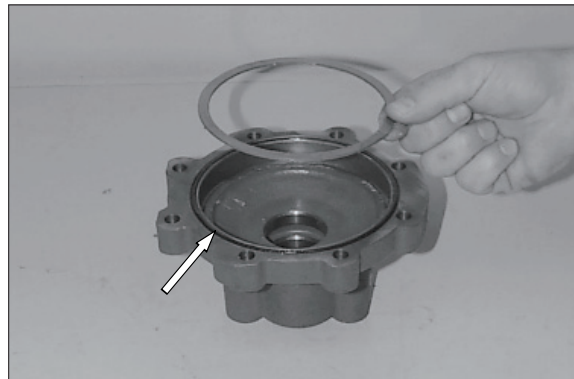

Figure 262

- (6) Grease the rectangular rings (arrows) and centrally align them.

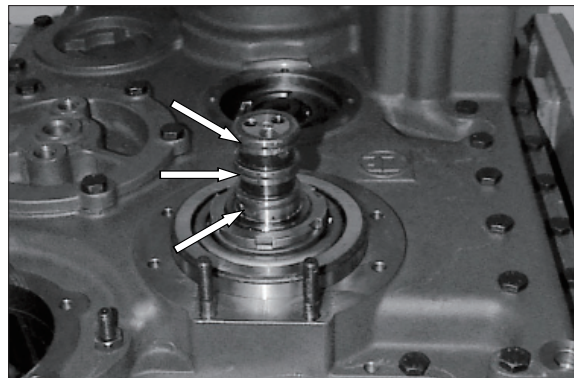

Figure 263

(7) Pull the bearing cover equally until contact.

· Torque limit (M10/8.8) :

4.69 kgf · m (33.9 lbf · ft)

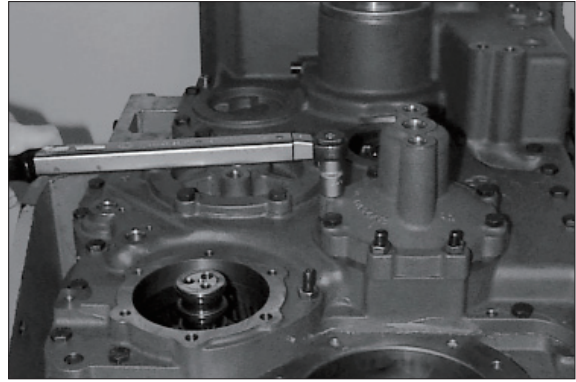

Figure 264

(8) Check the function of both clutches by means of compressed air.

※ In case of a decisive pressure loss, the possible cause might be the breakage of one or several rectangular rings (see figure 263).

Replace the rectangular rings, if required.

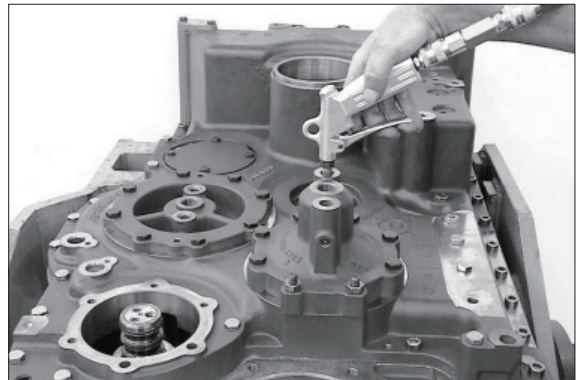

Figure 265

Adjust the bearing preload of clutch KV/K1 = 0.0~0.05 mm (figure 267~270)

※ For installation of a new bearing cover, both finished bores have to be sealed by means of a plug.
Installation position, see arrows/Figure 266.

- 1 Bearing cover-KV/K1
- 2 Plug
- (S) Special tool

※ Special tool
Hand mounting tool 5870 320 014
Ratchet spanner 5870 320 018

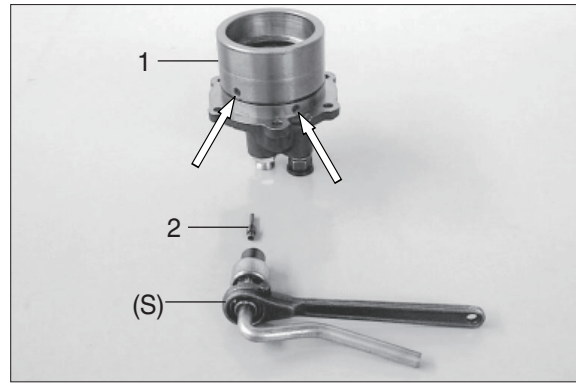

Figure 266

(1) Put the bearing outer ring over the bearing inner ring.

Housing dimension :
Press on equally the bearing outer ring and determine Dimension I, from the mounting face to the bearing outer ring.

Dimension I e.g 52.67 mm

※ Take several measuring points and determine the mean value.

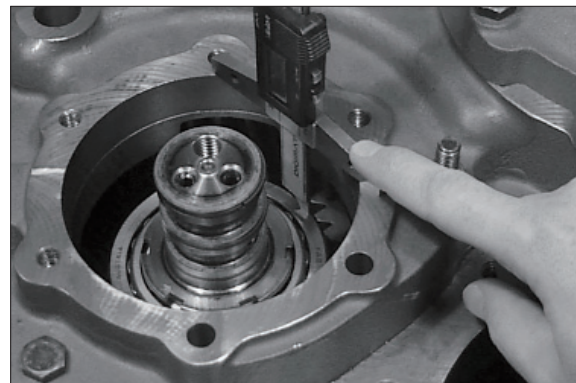

Figure 267

(2) Put the ring with the chamfer showing downwards into the bearing cover.

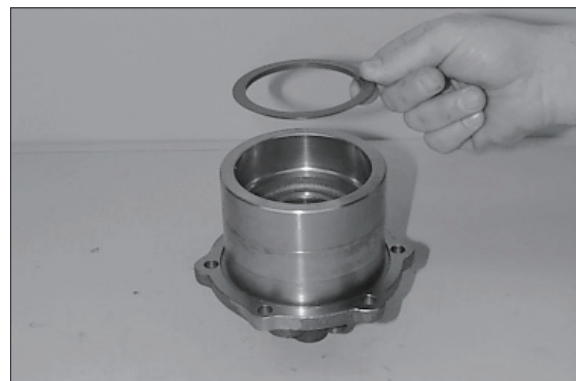

Figure 268

Cover dimension :

- (3) Determine Dimension II, from the mounting face to the ring.

Dimension II e.g 50.75 mm

※ Special tool

Digital depth gauge 5870 200 072

Gauge blocks 5870 200 067

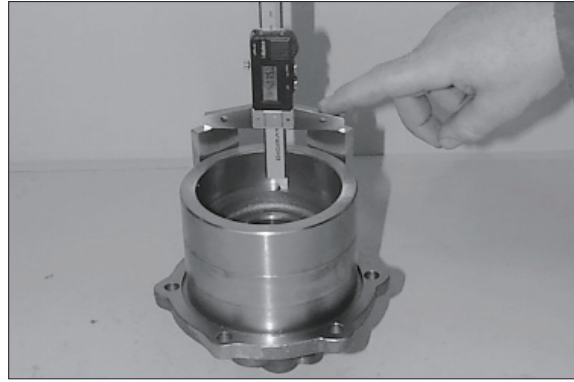

Figure 269

Example :

Dimension I 52.67 mm

Dimension II - 50.75 mm

Difference e.g. 1.92 mm

Bearing preload + 0.03 mm

Resulting shim (s) s = 1.95 mm

- (4) Put in the shim.



Figure 270

- (5) Install the bearing outer ring until contact.
Assemble the O-ring (arrow).



Figure 271

- (6) Grease the rectangular rings (arrows) and centrally align them.

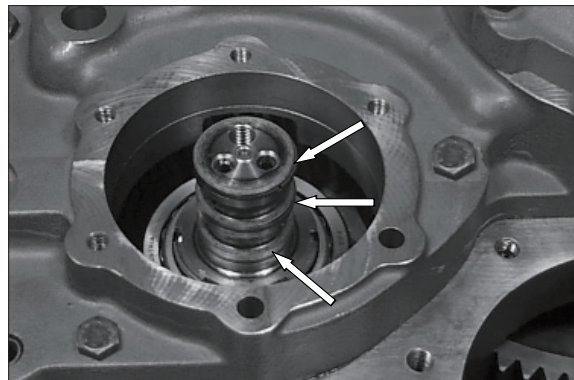

Figure 272

(7) Heat the bearing bore.

- ※ Special tool
- Hot-air blower 230V 5870 221 500
- Hot-air blower 115V 5870 221 501

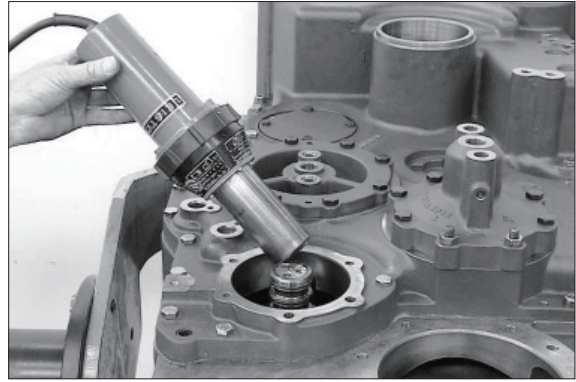

Figure 273

(8) Install two adjusting screws.
Place the bearing cover until contact and fasten it by means of hexagon screws.

- ※ Observe the radial installation position, see figure.
- ※ Special tool
- Adjusting screws 5870 204 007

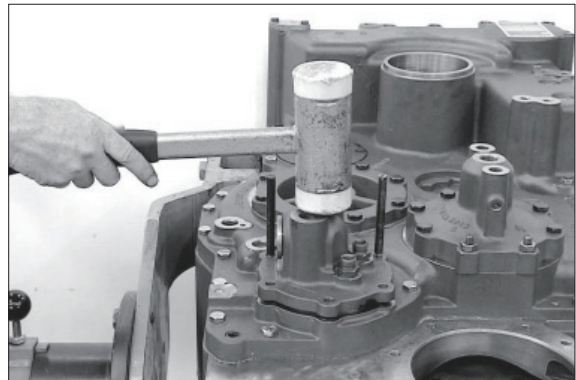

Figure 274

(9) Check the function of both clutches by means of compressed air.

- ※ In case of a decisive pressure loss, the possible cause might be the breakage of one or several rectangular rings (see arrow, figure 272).
Replace the rectangular ring (s), if required.

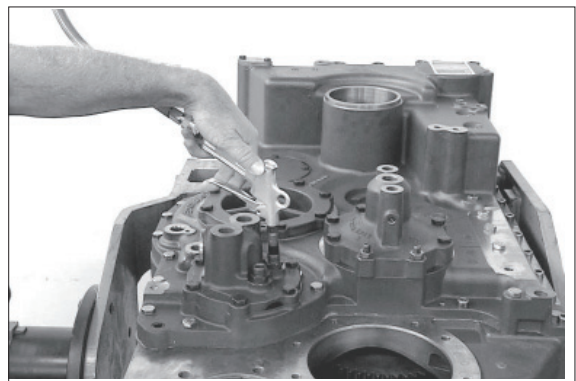

Figure 275

Output

Installation of the output shaft

(1) Heat the inner diameter of the output gear.

※ Special tool

Hot-air blower 230V 5870 221 500

Hot-air blower 115V 5870 221 501

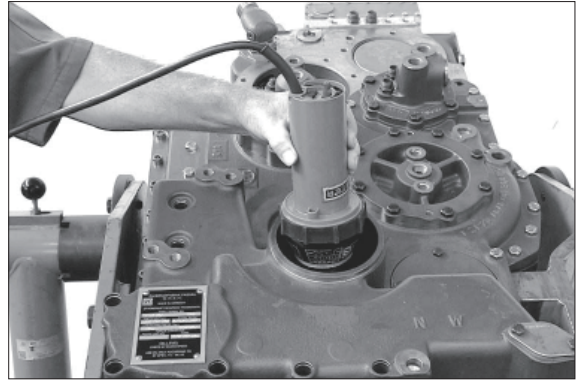

Figure 276

(2) Assemble the output shaft with the long gearing showing downwards until contact.

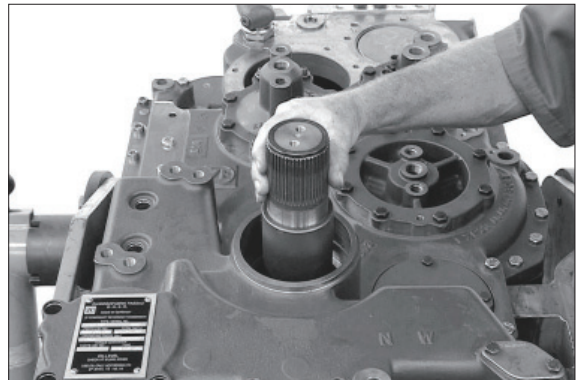

Figure 277

(3) Rotate the transmission housing into the vertical position (90°).

By means of the mounting tool the output shaft has preliminarily to be fixed axially (figure 278 and 279) at the convert-er side.

※ Special tool

Mounting tool 5870 048 265

Then rotate the transmission housing back again (90°).



Figure 278

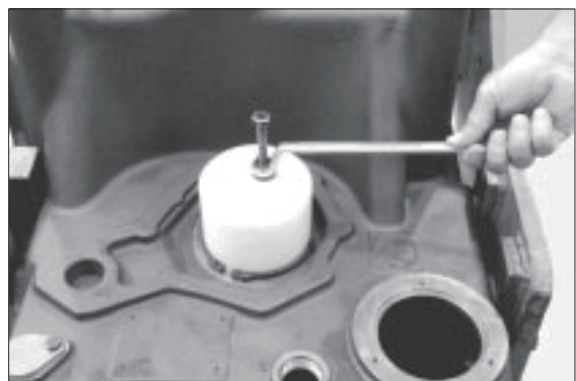

Figure 279

Adjust the axial play of the output bearing = 0.3~0.5 mm (figure 280~282)

- (4) Determine Dimension I, from plane face/housing to end face/output shaft.

Dimension I e.g 66.90 mm

※ Special tool

Digital depth gauge 5870 200 072

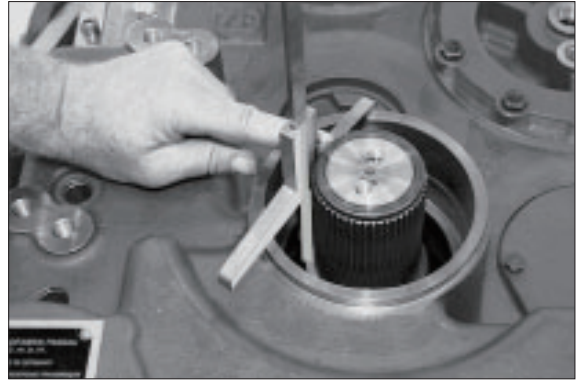

Figure 280

- (5) Measure Dimension II, from plane face/housing to contact face/ball bearing.

Dimension II e.g 64.20 mm

Example :

Dimension I 66.90 mm

Dimension II - 64.20 mm

Difference = 2.70mm

Required axial play e.g. - 0.40 mm

(0.3~0.5 mm)

Resulting shim s = 2.30 mm

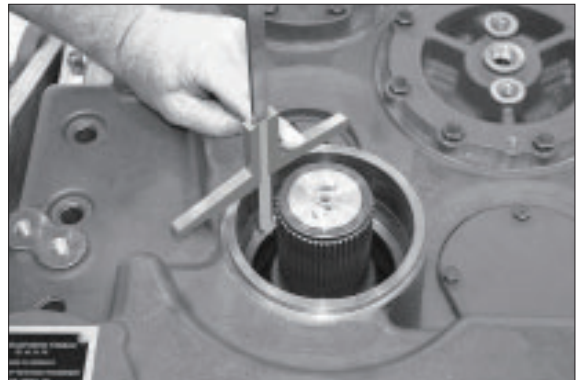

Figure 281

- (6) Install the shim.

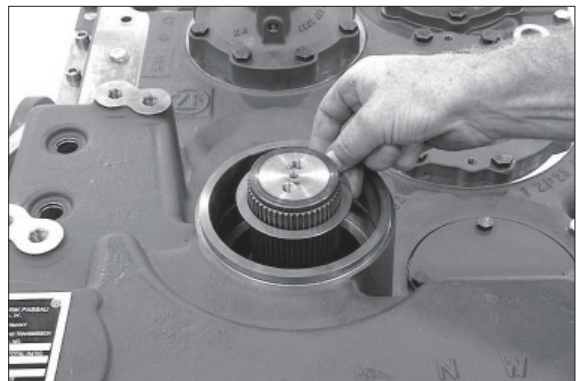

Figure 282

- (7) Install the ball bearing (figure 283) and pull it until contact by means of the output flange (figure 284).

Then remove the output flange again.

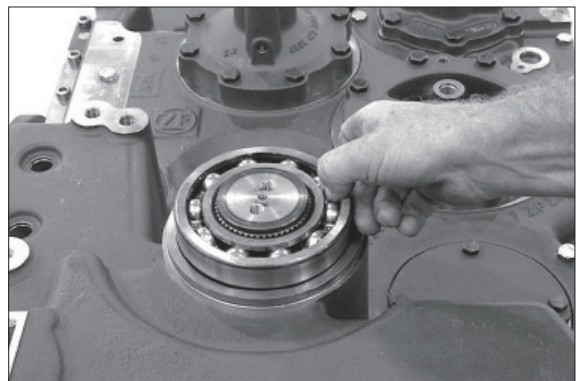

Figure 283

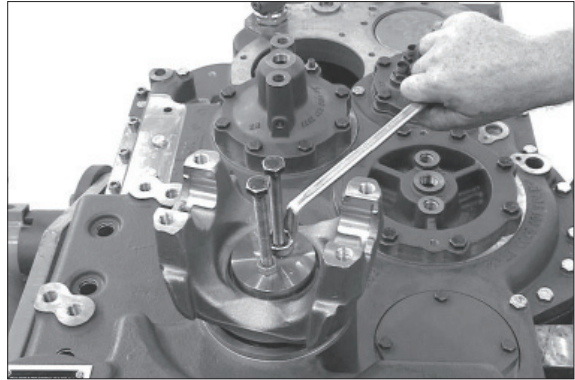

Figure 284

(8) Fasten the ball bearing by means of retaining ring.

※ Clamping pliers 5870 900 021

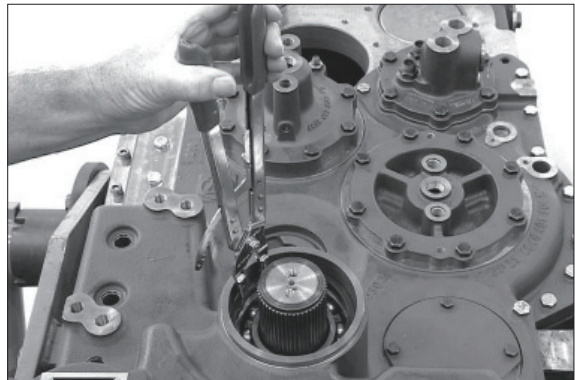

Figure 285

(9) Remove the converter-side mounting tool again.

Install the shaft seal, (arrow) with the sealing lip showing to the oil sump.

※ Using of the specified mounting tool (S), results in the exact installation position (without retaining ring = 20 mm). Grease the sealing lip.

※ Special tool
Mounting tool 5870 048 265

※ Depending on the version different shaft seals can be used :
Outer diameter rubber-coated-wet it with spirit. Outer diameter metallic-wet it with sealing compound (loctite, type No. 574).

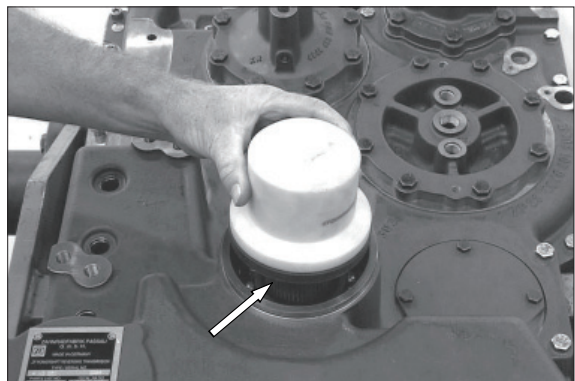

Figure 286

Output Flange

(1) Press on the screen sheet (arrow) until contact.

※ Observe the installation position, see figure 288.

※ Special tool
Pressing bush

5870 506 138

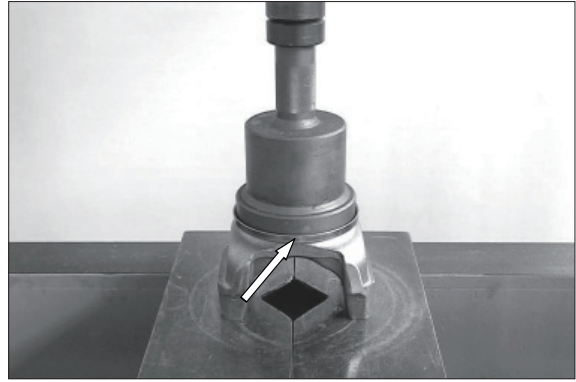

Figure 287

- 1 Screen sheet
- 2 Output flange

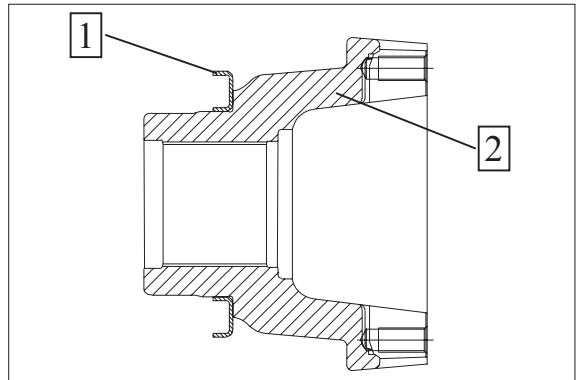

Figure 288

Adjust gap size $X = 0.3\sim 0.8$ mm
 (figure 289~292) :

- X Gap size
- 1 Shim
- 2 O-ring.

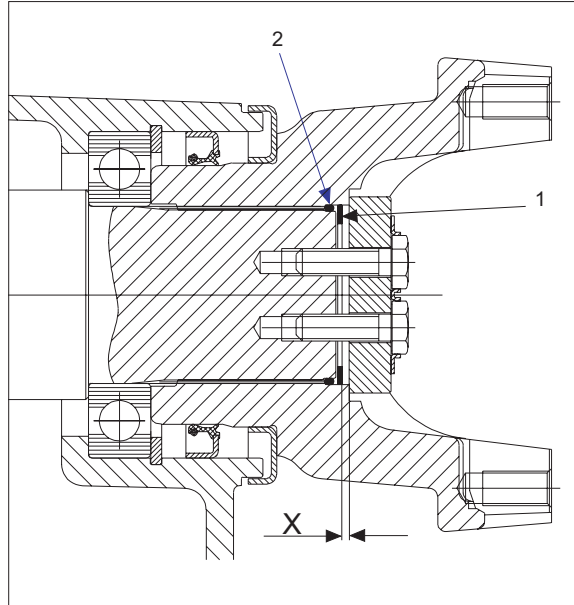

Figure 289

(1) Install the output flange until contact.

Measure Dimension I, from the plane face of the output flange to the end face of the output shaft.

Dimension I e.g.37.00 mm

※ Special tool

Digital depth gauge 5870 200 072

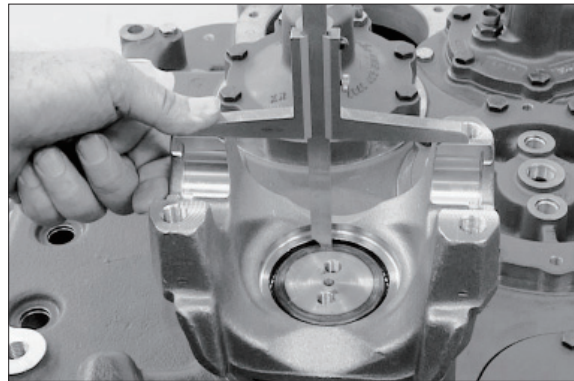

Figure 290

(2) Measure Dimension II, from the plane face to the collar of the output flange.

Dimension II e.g. 36.00 mm

Example :

Dimension I 37.00 mm

Dimension II - 36.00 mm

Difference = 1.00 mm

Gap size X e.g. - 0.50 mm

(0.3~0.8 mm)

Resulting shim s = 0.50 mm

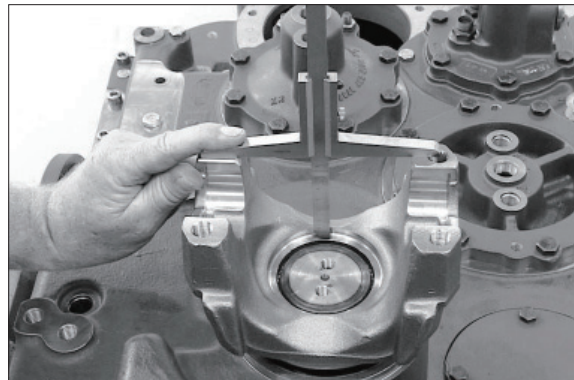

Figure 291

- (3) Place the O-ring (arrow) into the space between output flange and shaft (see also figure 289) and put on the shim.

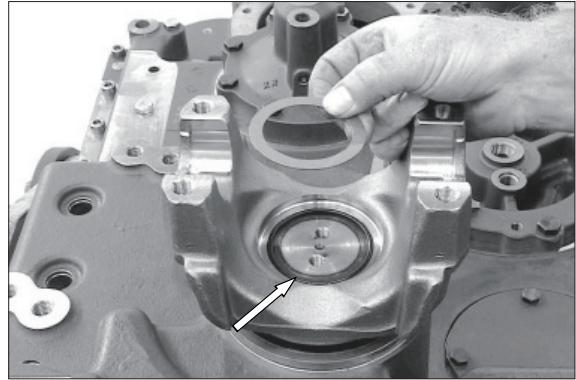

Figure 292

- (4) Put on the washer and fasten the output flange by means of hexagon screws.

- Torque limit (M10/8.8) :
4.69 kgf · m (33.9 lbf · ft)

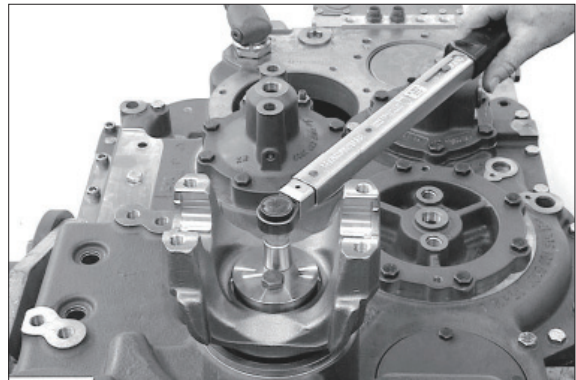

Figure 293

- (5) Fasten the hexagon screws by means of the lock plate.

- ※ Specail tool
Mounting tool 5870 057 009
Handle 5870 260 002

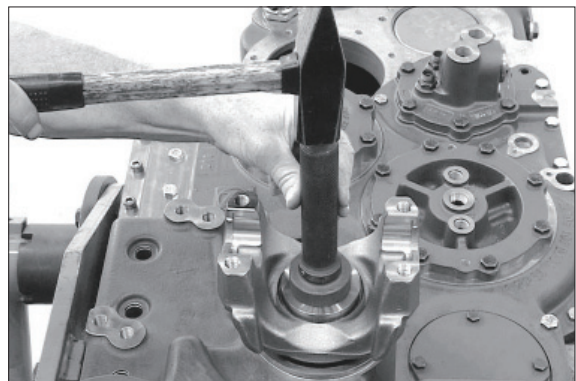

Figure 294

Output Flange (converter side)

(1) Install the shaft seal (arrow) with the sealing lip showing to the oil sump.

- ※ Using of the specified mounting tool, results in the exact installation position (with retaining ring = 7.0 mm). Grease the sealing lip.

※ Special tool
Mounting tool 5870 048 265

- ※ Depending on the version different shaft seals can be used :
Outer diameter rubber-coated-wet it with spirit. Outer diameter metallic-wet it with sealing compound (loctite, Type No. 574).

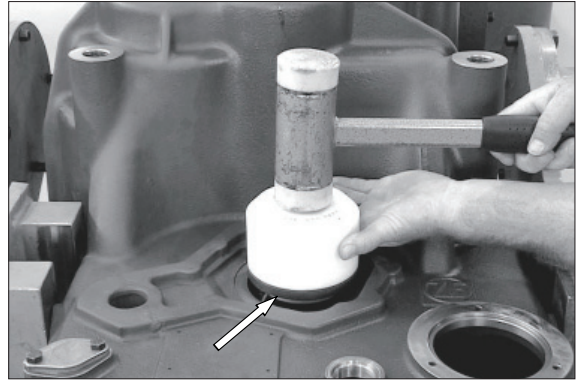

Figure 302

(1) Press the screen sheet (arrow) over the collar of the output flange until contact.

- ※ Observe the installation position, see figure 304.

※ Special tool
Pressing bush 5870 506 138

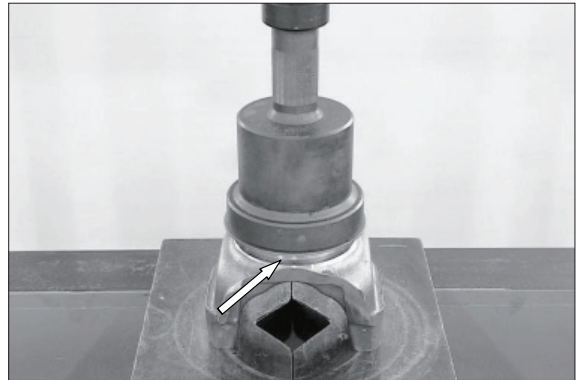

Figure 303

- 1 Screen sheet
- 2 Output flange

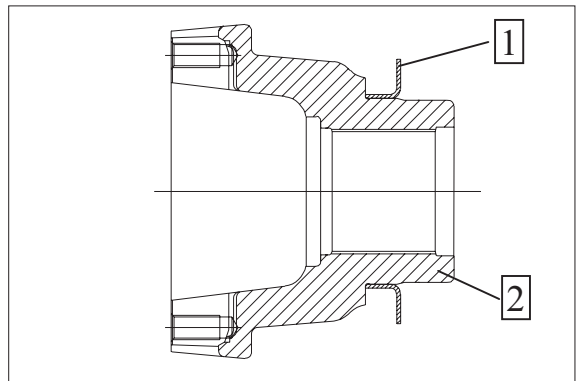

Figure 304

(2) Install the output flange until contact.

- ※ Setting of the gap size as well as fixing of the output flange is identical with the installation of the output flange at the transmission rearside, see page 3-155 and 3-156.



Figure 305

Installation of the idler shaft

(1) Align the layshaft gear and the single components centrally.
Heat the layshaft gearing (figure 306).

- ※ Special tool
Hot-air blower 230V 5870 221 500
Hot-air blower 115V 5870 221 501



Figure 306

(2) Install the adjusting screw.

- ※ Special tool
Adjusting screws 5870 204 007

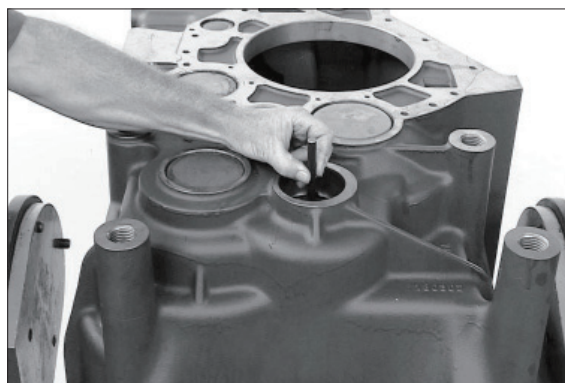

Figure 307

(3) Install the idler shaft until contact.

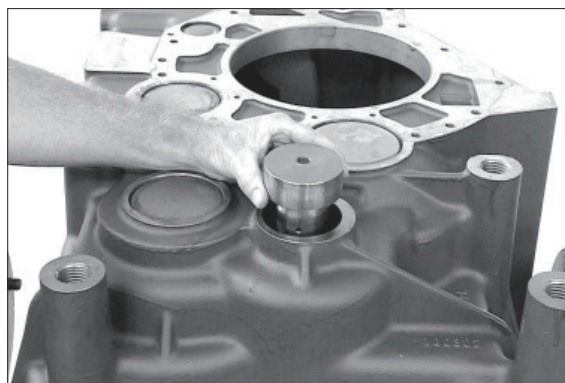

Figure 308

(4) Remove the adjusting screw and fasten the axle by means of hexagon screw.

※ Wet the thread of the hexagon screw with Loctite (type No. 243).

• Torque limit (M10/8.8) :
4.69 kgf · m (33.9 lbf · ft)

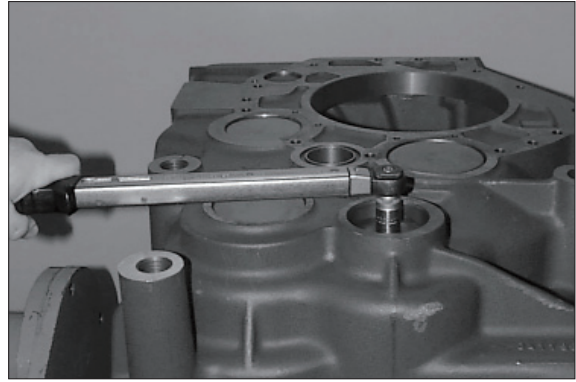

Figure 309

(5) Insert the sealing covers (arrow), with the concave side showing downwards, flush to the housing surface.

※ Wet contact face with Loctite (type No. 262).

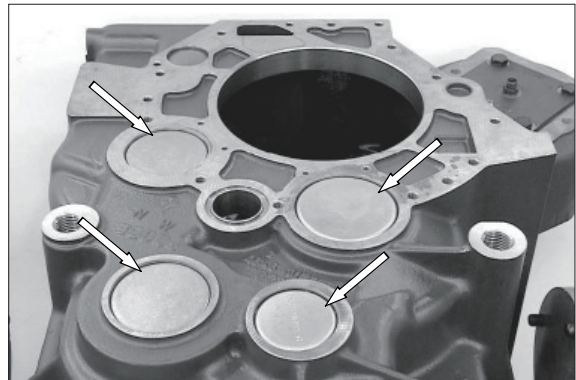

Figure 310

Transmission pump

- (1) Press the needle sleeve (arrow), with the reinforced coating towards the press-in tool until contact.

※ Special tool

Mounting tool 5870 058 041

Handle 5870 260 002

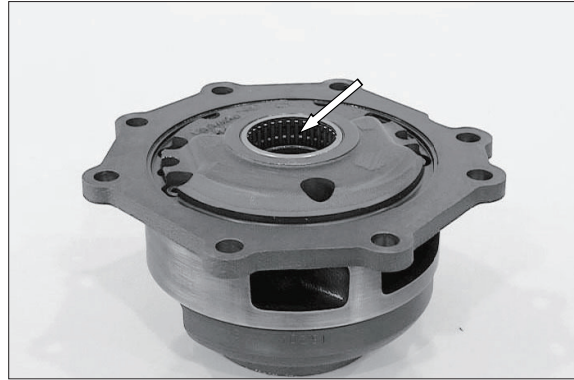

Figure 329

- (2) Snap the V-Rings (3EA) into the recess of the driver (internal gearing). Install the key (arrow).



Figure 330

- (3) Press the ball bearing over the collar of the driver until contact.



Figure 331

- (4) Install the ball bearing and driver respectively and press it until contact.

※ Pay attention to align the key to the keyway.



Figure 332

(5) Fasten the ball bearing by means of retaining ring.

- ※ Special tool
Set of internal pliers 5870 900 013



Figure 333

(6) Install the O-ring (arrow) and grease it.



Figure 334

(7) Heat the housing bore.

- ※ Special tool
Preheating bush 5870 801 006
Hot-air blower 230V 5870 221 500
Hot-air blower 115V 5870 221 501

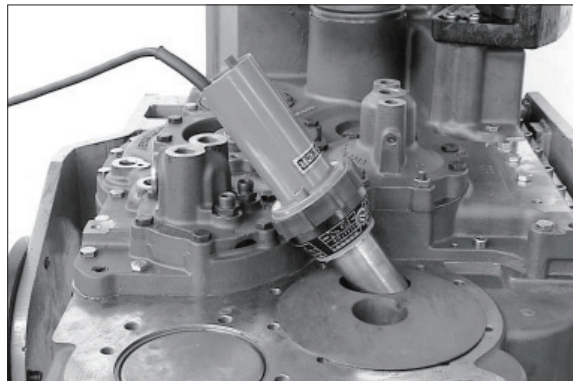

Figure 335

(8) Install two adjusting screws and assemble the pump until contact.

- ※ Observe the radial installation position.
- ※ Special tool
Adjusting screws 5870 204 021

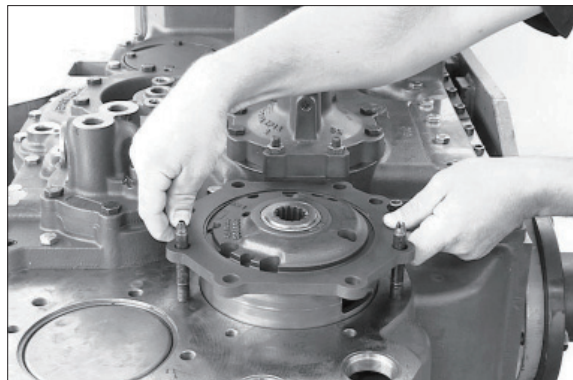

Figure 336

(9) Put the O-ring (arrow) into the annular groove of the pump flange.

- ※ Depending on the transmission version, differences as regards the version and fastening of the pump flange are possible. Obligatory is the respective parts list.

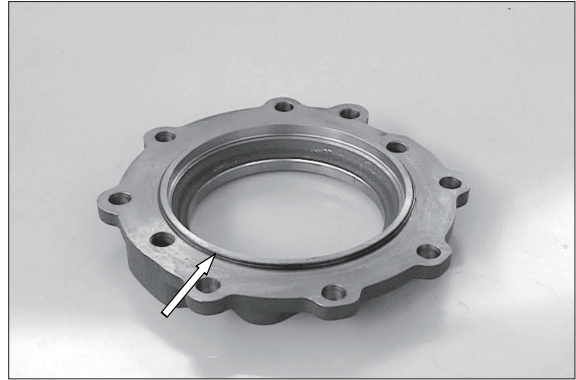

Figure 337

(10) Fasten the pump flange and the pump respectively by means of hexagon screws.

- ※ Wet thread of both hexagon screws (position, see arrows) with Loctite, Type No. 574 (through holes).

- Torque limit (M12/8.8) :
8.06 kgf · m (58.3 lbf · ft)

Then rotate the transmission housing by 90°.

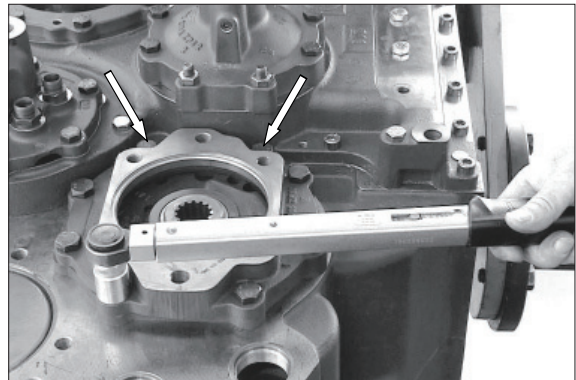

Figure 338

(11) Snap-in and lock the rectangular ring (arrow).

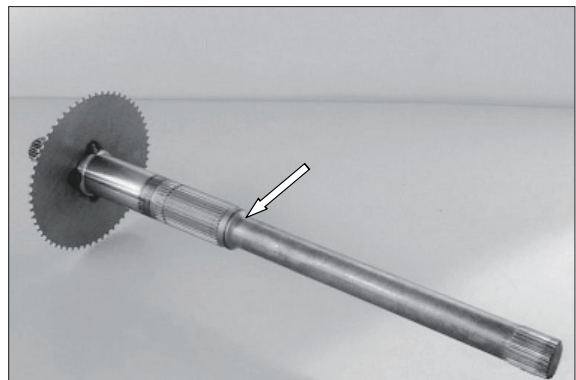

Figure 339

(12) Install both shims (each 2.0 mm thick)

- ※ Use assembly grease.



Figure 340

(13) Heat the bevel bearing inner ring.

※ Special tool

Hot-air blower 230V 5870 221 500

Hot-air blower 115V 5870 221 501

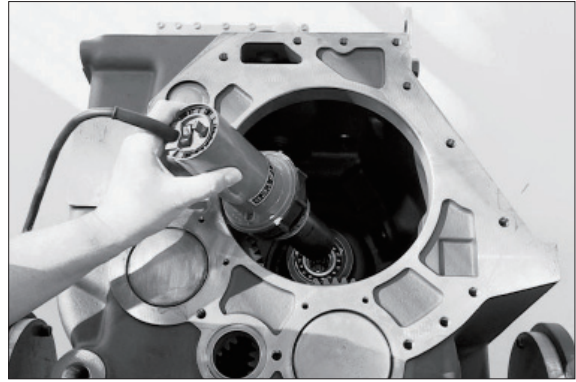

Figure 341

(14) Install the input shaft until contact.

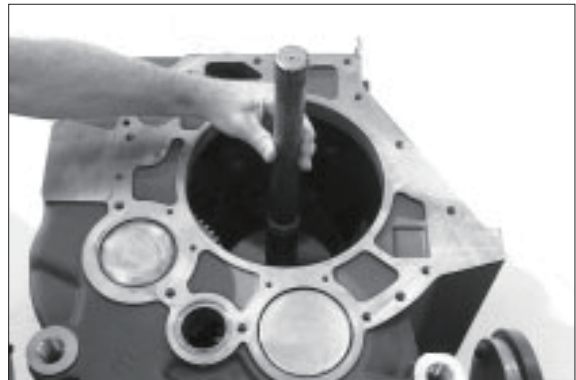

Figure 342

(15) Fasten the input shaft by means of clamping plate and cap screw (arrow).

· Torque limit (M10/8.8) :

3.26 kgf · m (23.6 lbf · ft)

※ Wet thread of the cap screw with Loctite (type No. 243).

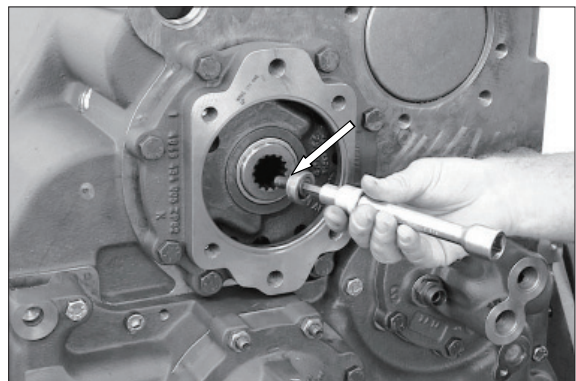

Figure 343

Input-Converter Bell

- ※ To install a new converter bell the finished bores (3EA) have to be sealed with plugs. Installation position, see arrow, figure 344.
- ※ Special tool
Lever riveting tongs 5870 320 016

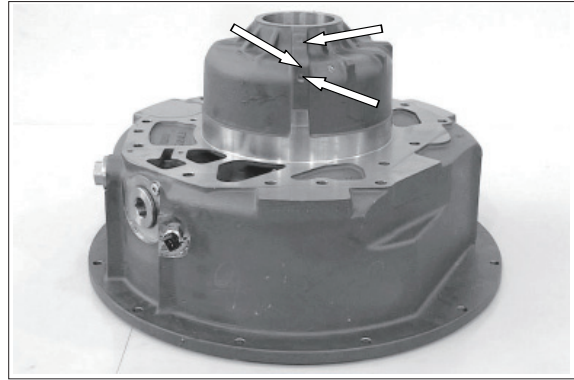

Figure 344

- (1) Locate the bearing outer ring into the housing bore until contact and install the bearing inner ring, see arrow.

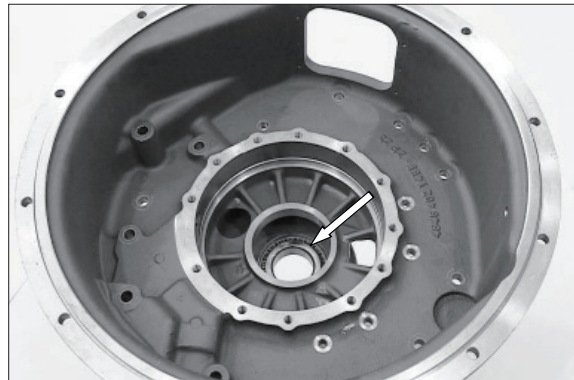

Figure 345

- (2) Install the spur gear (arrow) with the long collar showing upwards and position it.



Figure 346

- (3) Heat the spur gear bore (arrow).

- ※ Special tool
Hot-air blower 230V 5870 221 500
Hot-air blower 115V 5870 221 501



Figure 347

(4) Install the input shaft until contact.

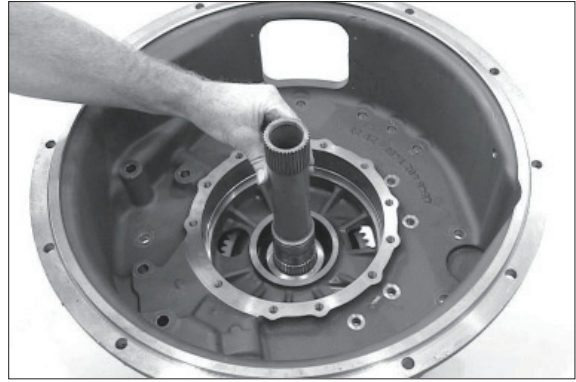

Figure 348

(5) Heat the bearing inner ring and install it until contact.

▲ Use safety gloves.



Figure 349

(6) Install the bearing outer ring until contact.

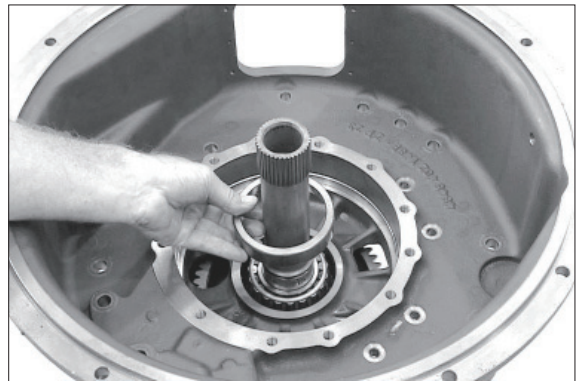

Figure 350

(7) Snap in the rectangular ring (arrow) into the annular groove of the input shaft and lock it.
Then grease the rectangular ring and centrally align it.

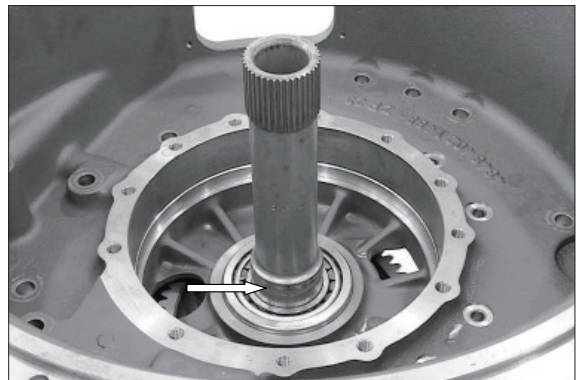

Figure 351

(8) Install the converter safety valve (arrow 1) and fasten it by means of slotted pin (arrow 2).

※ Flush-mount slotted pin to recess.

Put the O-ring (arrow 3) into the annular groove.

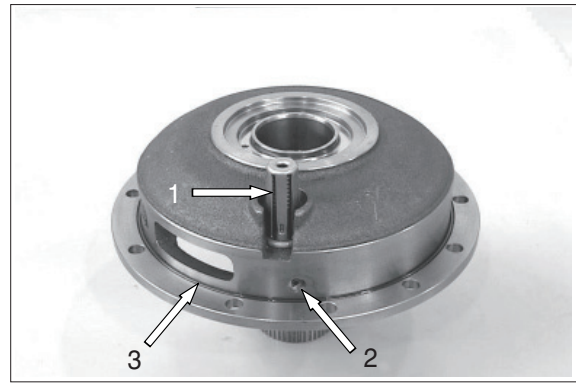

Figure 352

(9) Press the needle bearing (arrow), with the reinforced coating towards the press-in tool into the bore of the bearing cover until contact.

※ Special tool

Mounting tool 5870 058 051

Handle 5870 260 002

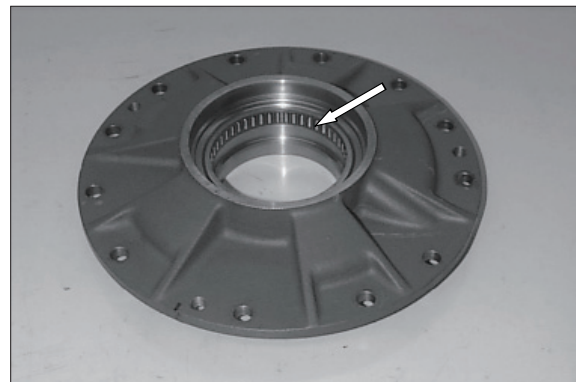

Figure 353

(10) Flush-mount the shaft seal (arrow) with the sealing lip showing (downwards) to the oil sump.

※ Wet the outer diameter with spirit.
Grease the sealing lip.

※ Special tool

Mounting tool 5870 048 030

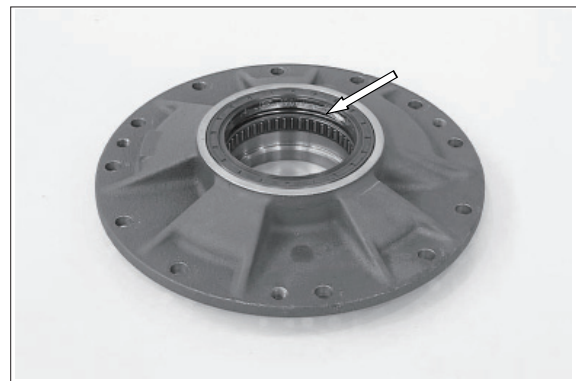

Figure 354

※ Make the following steps (figure 355~358) in direct time sequence to secure the precise contact of the oil supply flange.

(11) Heat the housing bore.

※ Special tool

Preheating bush 5870 801 006

Hot-air blower 5870 221 500

Hot-air blower 5870 221 501



Figure 355

(12) Install two adjusting screws and put in the oil supply flange until contact.

※ Observe the radial installation position.

※ Special tool

Adjusting screws 5870 204 007

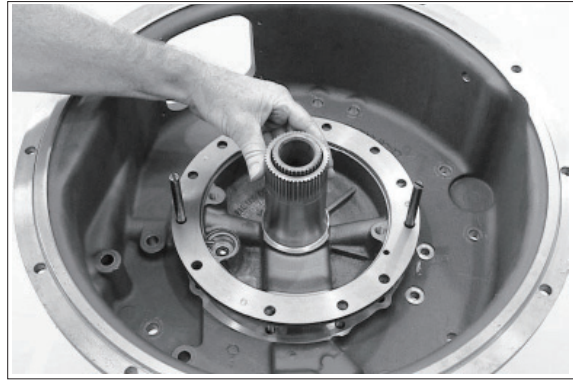

Figure 356

(13) Place the O-ring (arrow) with assembly grease into the annular groove of the bearing cover.

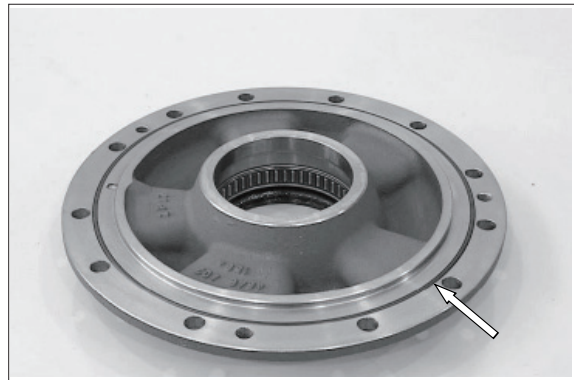

Figure 357

(14) Put on the bearing cover and fasten it by means of hexagon screws.

· Torque limit (M10/8.8) :

4.69 kgf · m (33.9 lbf · ft)



Figure 358

(15) Install the single components according to the opposite figure.

1 Screw plug : 15.3 kgf · m (110 lbf · ft)

2 Screw plug : 2.55 kgf · m (18.4 lbf · ft)

3 Temperature sensor :

2.55 kgf · m (18.4 lbf · ft)

and screw plug respectively (depending on the version) : 3.57 kgf · m (25.8 lbf · ft)

※ Always install new O-ring.

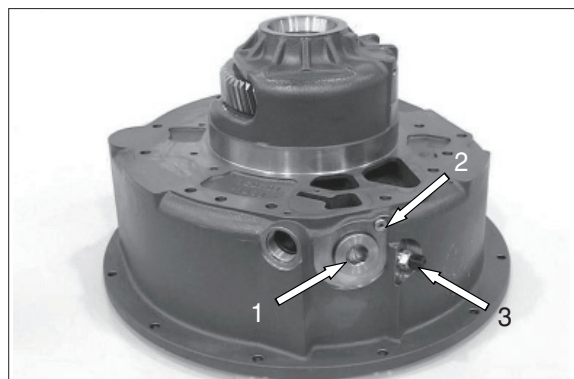

Figure 359

Converter pressure back-up valve
(figure 360~361)

- (1) Install the slotted pin (6×50 mm) until contact.

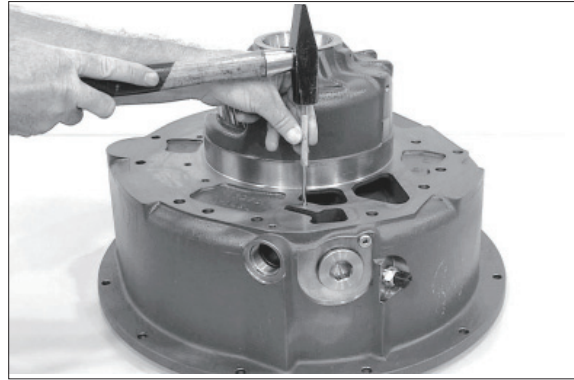

Figure 360

- (2) Assemble piston and compression spring. Provide screw plug with a new O-ring and install it.

- Torque limit (M36×1.5) :
13.3 kgf · m (95.9 lbf · ft)

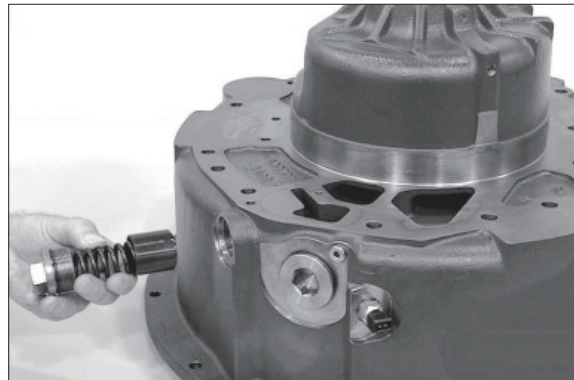

Figure 361

- (3) Fasten the gasket and cover plate by means of hexagon screws (install the washers).

- Torque limit (M6/8.8) :
0.97 kgf · m (7.0 lbf · ft)



Figure 362

- (4) Install two adjusting screws and put on the gasket (arrow 1). Put the O-ring (arrow 2) into the annular groove.

- ※ Special tool
Adjusting screws 5870 204 021

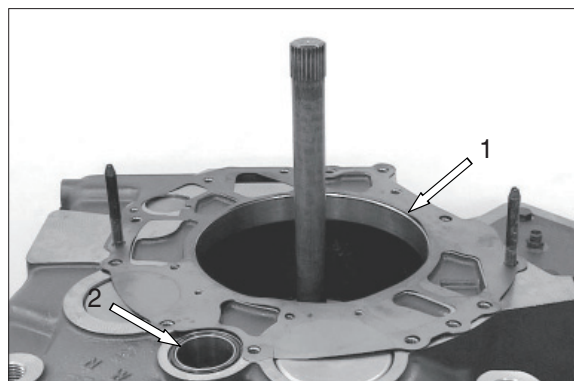

Figure 363

(5) Install the converter bell by means of lifting tackle until contact.

※ Slight rotary motions of the input shaft facilitate the installation (protect teeth from damage). Observe the radial installation position.

※ Special tool

Lifting tackle 5870 281 047

Eyebolts assortment 5870 204 002



Figure 364

(6) Fasten the converter bell by means of hexagon screws.

· Torque limit (M8/10.9) :

3.47 kgf · m (25.1 lbf · ft)

· Torque limit (M12/10.9) :

11.7 kgf · m (84.8 lbf · ft)



Figure 365

(7) Fasten flexible plate (3EA) by means of hexagon screws (install the washers).

※ Wet thread of the hexagon screws with Loctite (type No. 243).

· Torque limit (M10/8.8) :

4.69 kgf · m (33.9 lbf · ft)

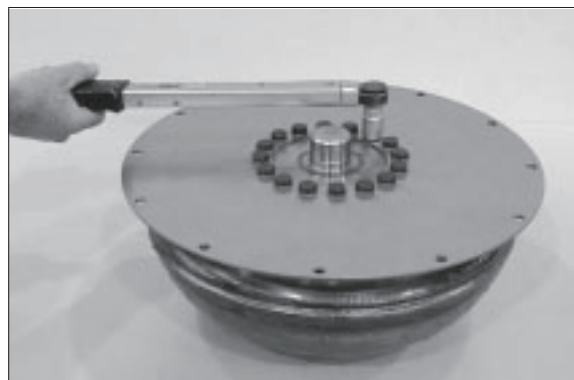

Figure 366

(8) Install the rectangular ring (arrow) into the annular groove and lock it.

Then grease the rectangular ring and centrally align it.



Figure 367

(9) Assemble converter by means of lifting tackle until contact (figure 368).

※ At a control dimension < 43 mm, the exact installation position of the converter is ensured, see Figure 369.

※ Special tool

Eyebolts assortment 5870 204 002

Lifting chain 5870 281 047

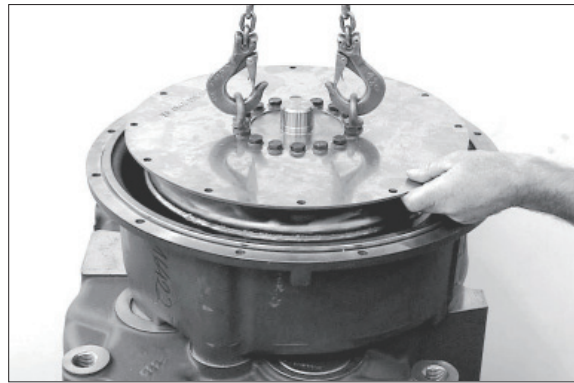

Figure 368

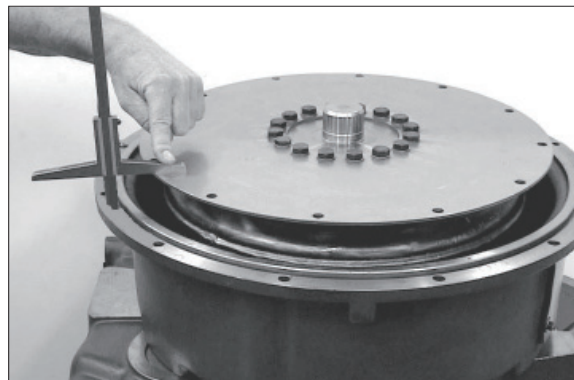

Figure 369

⚠ Until installation of the transmission, fix the converter axially, see figure 370.

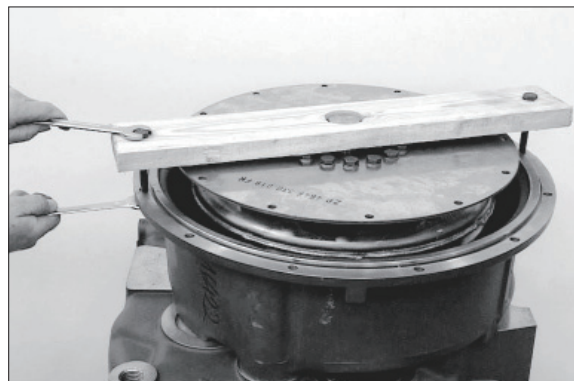

Figure 370

Coarse Filter

(1) Install filter (assy) into the housing bore.

※ Oil the sealing (arrow).

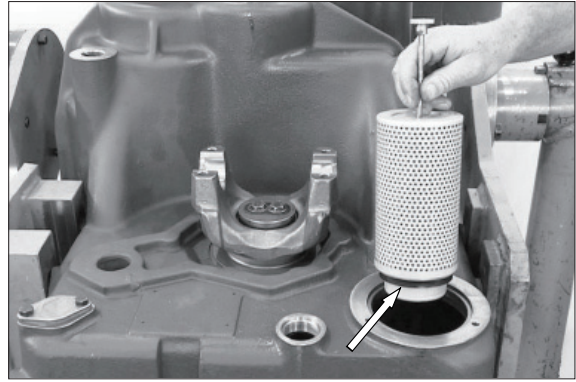

Figure 371

(2) Fasten the cover by means of hexagon screws (install the washers).

※ Install the new O-ring (arrow).

• Torque limit (M8/8.8) :

2.35 kgf · m (17.0 lbf · ft)

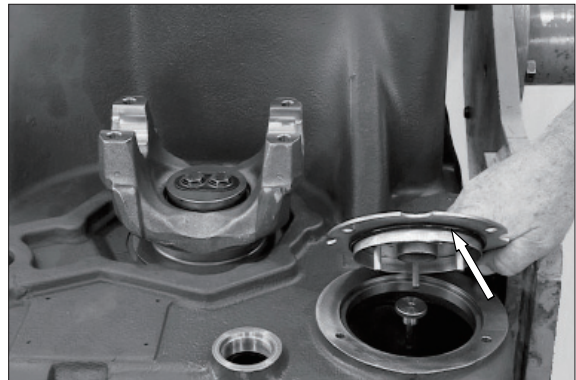

Figure 372

Inductive and speed transmitters

(1) Following sketches show the installation position of the single inductive and speed transmitters.

- | | | |
|----|-----------------------|------------------------|
| 14 | Inductive transmitter | n-Turbine |
| 9 | Inductive transmitter | n-Engine |
| 5 | Inductive transmitter | n-Internal speed input |
| 13 | Speed transmitter | n-Output |

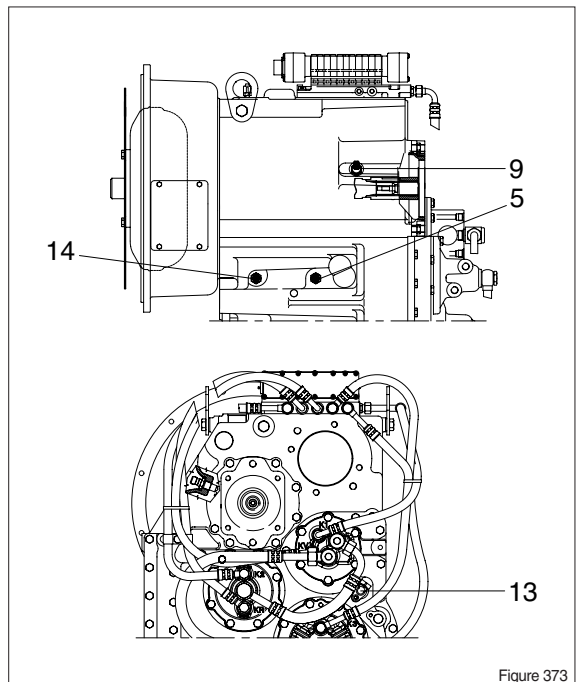

Figure 373

※ The following figures describe the installation and setting respectively of the inductive transmitter n-Engine (9).

Installation of the inductive transmitter n-Turbine (14) and n-internal speed input (5) is to be made analogously.

Observe the different setting dimensions "X" :

▲ Inductive transmitter n-Engine (9)

X = 0.5^{+0.3} mm

Inductive transmitter n-Turbine (14)

X = 0.5^{+0.3} mm

Induct. transmitter n-int. speed input (5)

X = 0.3^{±0.1} mm

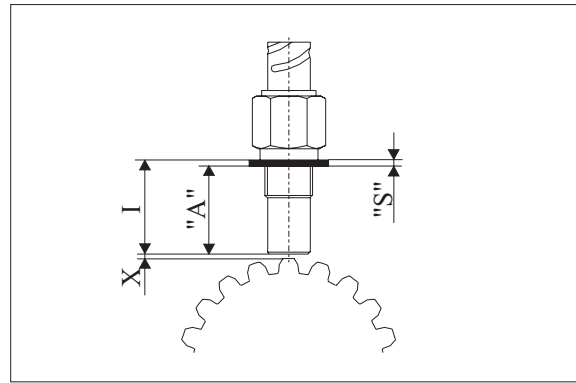

Figure 375

Adjust Dimension "X" by means of shim ring (s) (figure 376~381)

(1) Measure Dimension I on the inductive transmitter, from contact face to screw-in face.

※ Dimension I e.g 30.00 mm

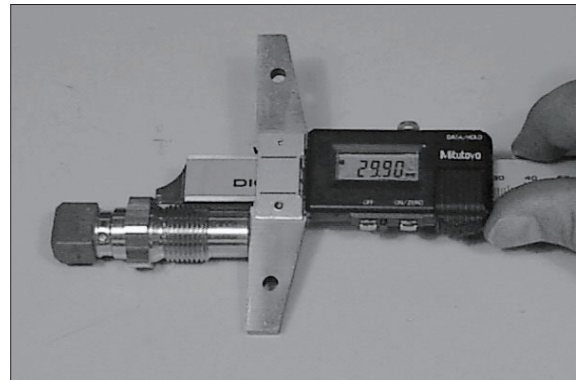

Figure 376

(2) Turn in the counting disc radially until one tooth tip is centrally to the inductive transmitter bore.

Turn the plug gauge until contact.

Locate anvil at the tooth tip and lock it by means of threaded pin (figure 377 and 378).

※ Special tool
Plug gauge 5870 200 104

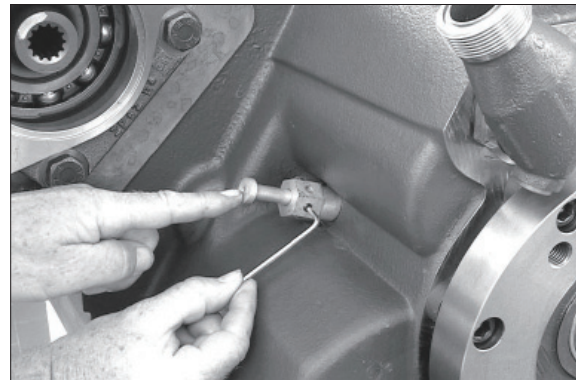

Figure 377

※ Special tool
Plug gauge 5870 200 104

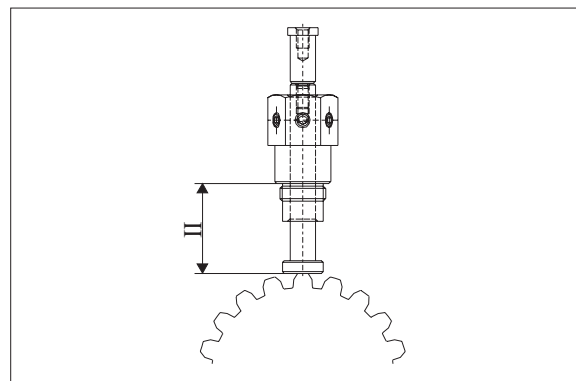

Figure 378

- (3) Turn out the plug gauge and determine Dimension II (also see figure 378).

Dimension II e.g 30.10 mm

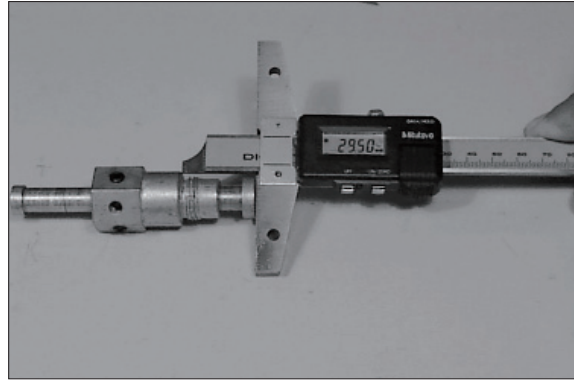

Figure 379

Example "A₁" :

$$\begin{array}{r}
 \text{Dimension II} \quad \quad \quad \underline{30.10 \text{ mm}} \\
 \text{Dimension X (0.5}^{+0.3} \text{ mm)} \quad - \underline{0.60 \text{ mm}} \\
 \text{Results in installation dimension A} \\
 \quad \quad \quad \quad \quad \quad \quad \quad = \underline{29.50 \text{ mm}}
 \end{array}$$

Example "A₂" :

$$\begin{array}{r}
 \text{Dimension I} \quad \quad \quad \underline{30.00 \text{ mm}} \\
 \text{Installation dimension A} \quad - \underline{29.50 \text{ mm}} \\
 \text{Results in shim ring (s)} \quad s = \underline{0.50 \text{ mm}}
 \end{array}$$

- (4) Install the adequate shim ring (s) and wet the thread (arrow) with Loctite (type No. 574).

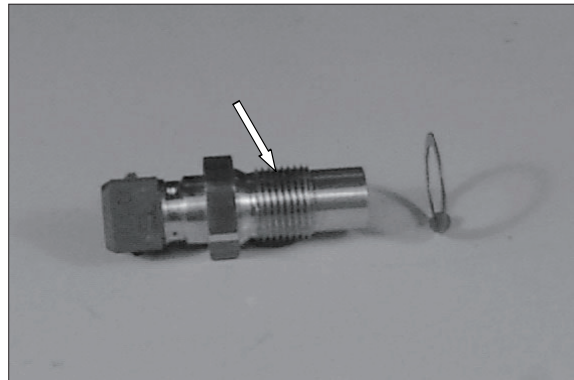

Figure 380

- (5) Install the inductive transmitter n-Engine (9), see arrow.

· Torque limit : 3.06 kgf · m (22.1 lbf · ft)

Set and install the inductive transmitter n-Turbine (14) and n-internal speed input (5) analogously.

- ※ Observe the different setting dimensions. Installation position of the single inductive transmitters, also see page 3-171.

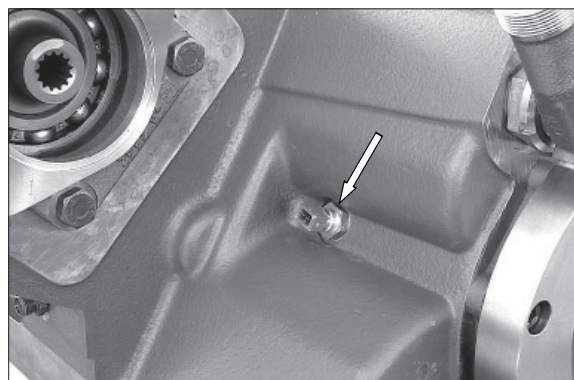

Figure 381

Install speed transmitter n-Output/Speedo (13) (figure 382~387)

- 1 Housing
- 2 Spur gear K3
- 3 Disc carrier
- 13 Speed transmitter (hall sensor)
- X** Setting dimension "X" =1.0+0.5 mm

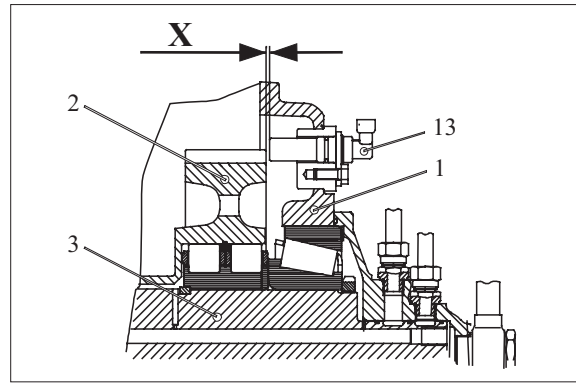

Figure 382

(1) Opposite figure shows the speed transmitter (hall sensor).



Figure 383

(2) Determine Dimension I, from the housing face to spur gear K3.

Dimension I e.g 39.70 mm

- ※ Special tool
- Digital depth gauge 5870 200 072

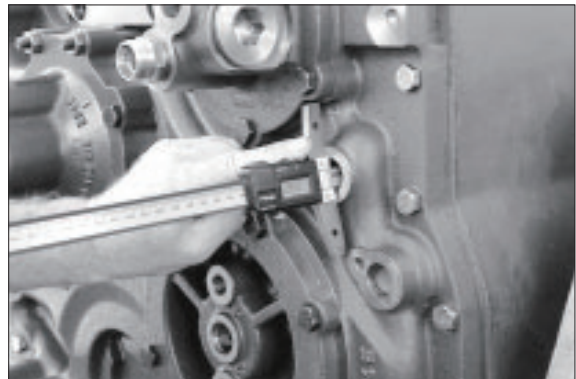

Figure 384

(3) Measure Dimension II, from the contact face to the mounting face.

Dimension II e.g 40.00 mm

- ※ Special tool
- Digital depth gauge 5870 200 072

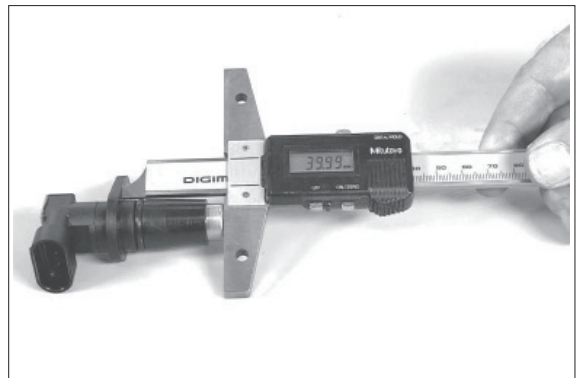

Figure 385

Example "B₁" :

$$\begin{array}{r} \text{Dimension I} \qquad \qquad \qquad \underline{39.70 \text{ mm}} \\ \text{Dimension X}(1.0+0.5\text{mm}) \quad - \underline{1.20 \text{ mm}} \\ \text{Results in installation dimension} \\ \hline \qquad \qquad \qquad \qquad \qquad \qquad = \underline{38.50 \text{ mm}} \end{array}$$

Example "B₂" :

$$\begin{array}{r} \text{Dimension II} \qquad \qquad \qquad \underline{40.00 \text{ mm}} \\ \text{Installation dimension A} \quad - \underline{38.50 \text{ mm}} \\ \text{Results in shim(s)} \qquad \qquad \quad s = \underline{1.50 \text{ mm}} \end{array}$$

(4) Install shims (3EA, s = 0.50 mm) and grease the O-ring (arrow).

(5) Fasten the speed transmitter by means of cap screw.

- Torque limit (M8/8.8) :
2.35 kgf · m (17.0 lbf · ft)

※ Installation position of the speed transmitter, also see page 3-171.

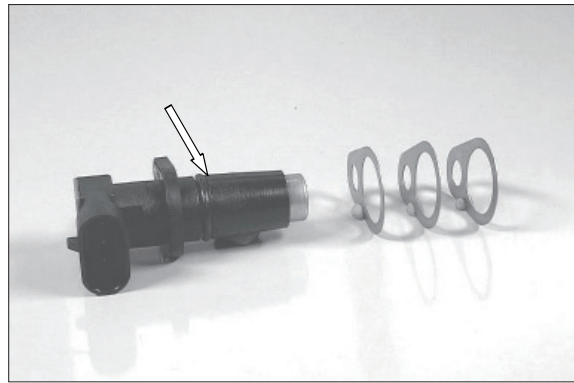

Figure 386

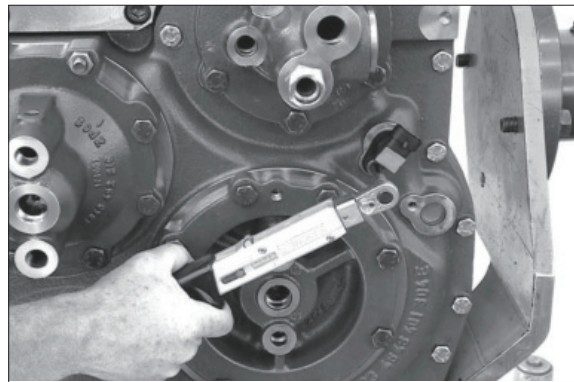

Figure 387

3. AXLE

• FRONT AXLE

1) DISASSEMBLY OF OUTPUT AND BRAKE

(1) Fasten axle on assembly truck.

※ Special tool

Assembly truck 5870 350 000

Holding fixtures 5870 350 077

Clamps 5870 350 075

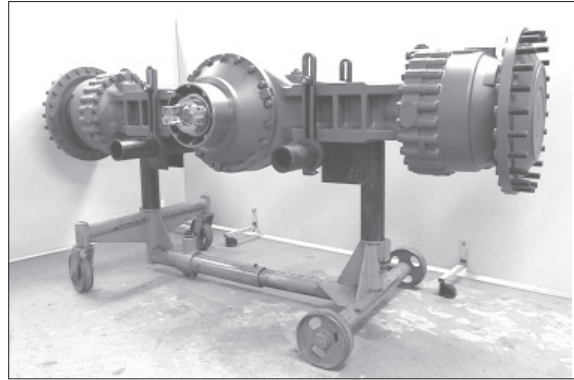

7577AAXF001

(2) Loosen screw plugs (3EA, see Figure 7577AAXF002 and 003) and drain oil from axle casing.

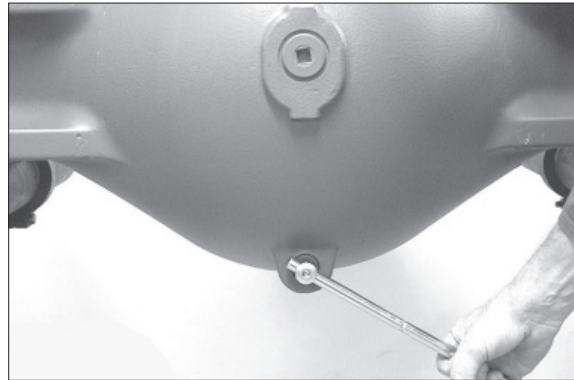

7577AAXF002

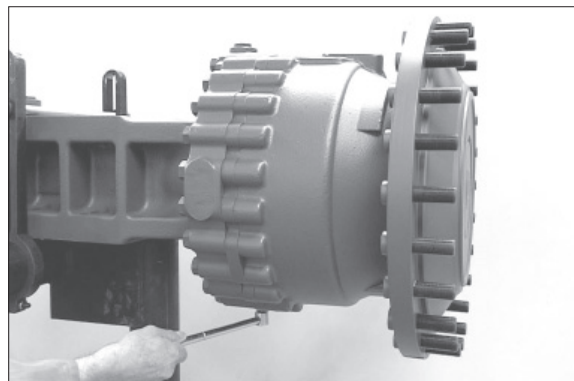

7577AAXF003

(3) Press off cover from the output shaft.

※ Special tool

Pry bar set 5870 345 065

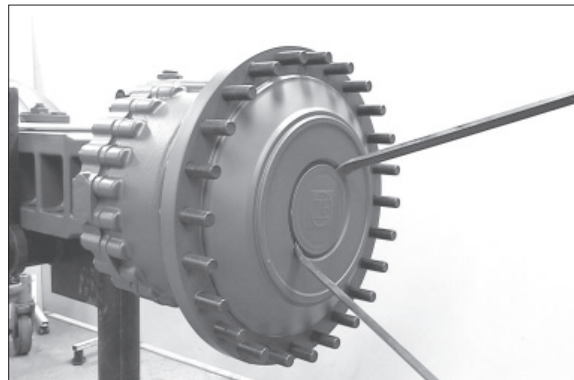

7577AAXF004

(4) Pull slotted pin by means of the striker out of the bore in the slotted nut.

- ※ Special tool
Striker 5870 650 001

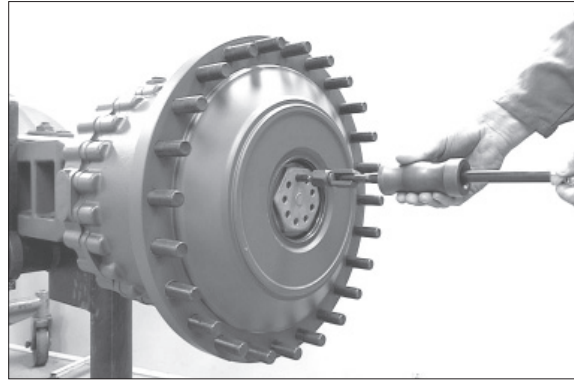

7577AAXF005

(5) Loosen slotted nut.

- ※ Special tool
Socket spanner 5870 656 078
Centering bracket 5870 912 028

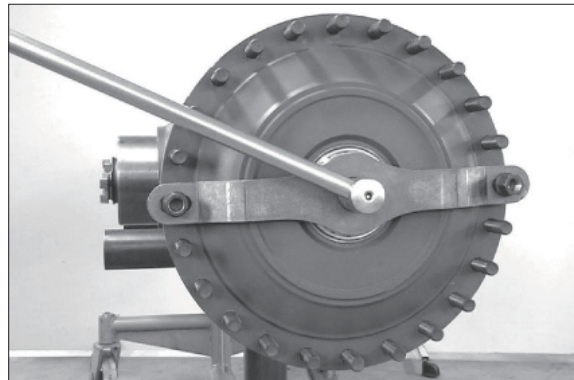

7577AAXF006

(6) Secure output by means of lifting tackle and loosen hexagon screws.

- ※ Special tool
Lifting bracket 5870 281 043

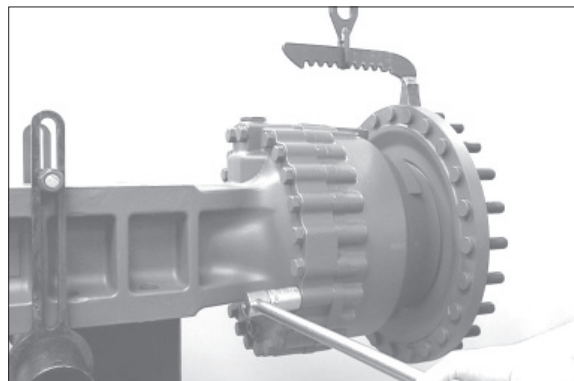

7577AAXF007

(7) Separate complete output from the axle casing.

- ※ Pay attention to released O-ring (see arrow).

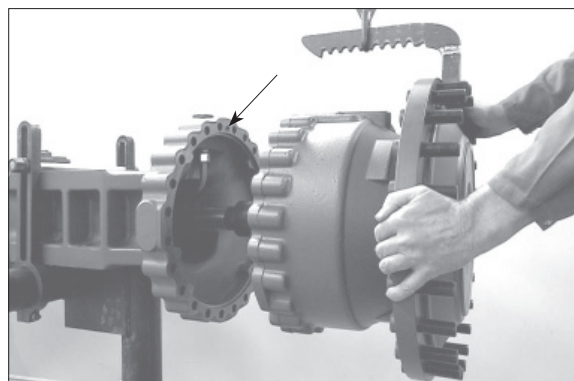

7577AAXF008

- (8) Pull stub shaft out of the sun gear shaft.
※ Pay attention to possibly released shim(s).

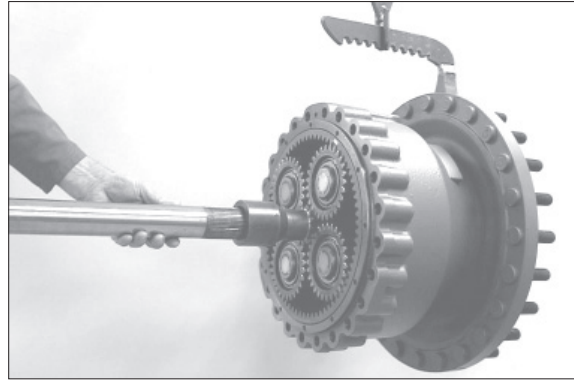

7577AAXF009

- (9) Remove shim(s) from the sun gear shaft.



7577AAXF010

- (10) Pull sun gear shaft out of the planet gears.

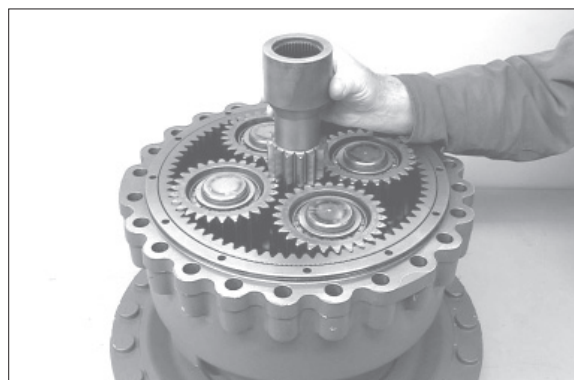

7577AAXF011

- (11) Lift planet carrier out of the brake housing.
※

Special tool
Internal extractor 5870 300 019

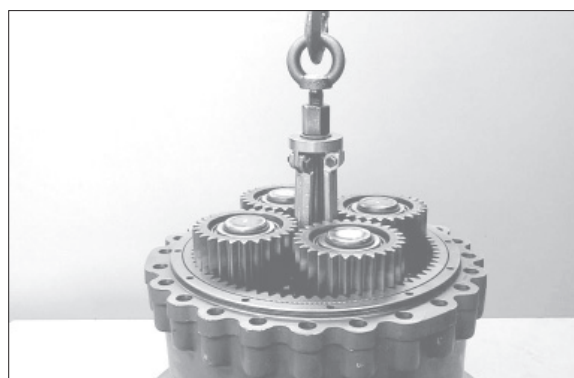

7577AAXF012

(12) Squeeze out the retaining ring.

- ※ Special tool
Set of external pliers 5870 900 015

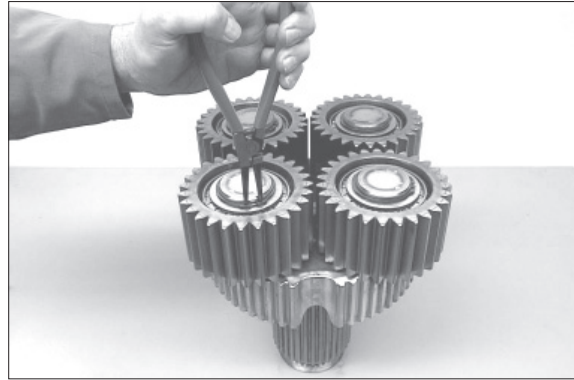

7577AAXF013

(13) Pull off the planet gear and remove the released bearing inner ring.

- ※ Special tool
Three-armed puller 5873 971 002



7577AAXF014

(14) Pull off the bearing inner ring.

- ※ Special tool
Gripping insert 5873 001 058
Basic set 5873 001 000



7577AAXF015

(15) Separate ring gear from the brake housing by means of two-armed puller.

- ※ Special tool
Two-armed puller 5870 970 007

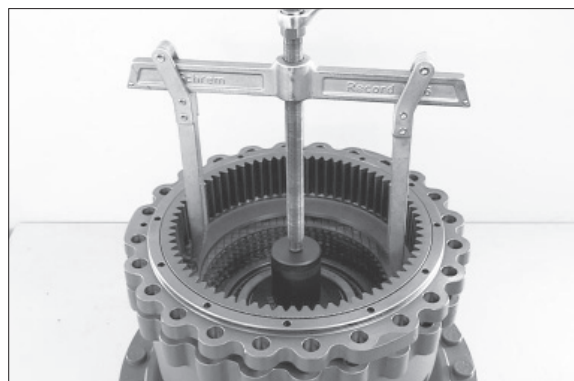

7577AAXF016

(16) Remove O-rings (see arrows) from the annular grooves of the ring gear.

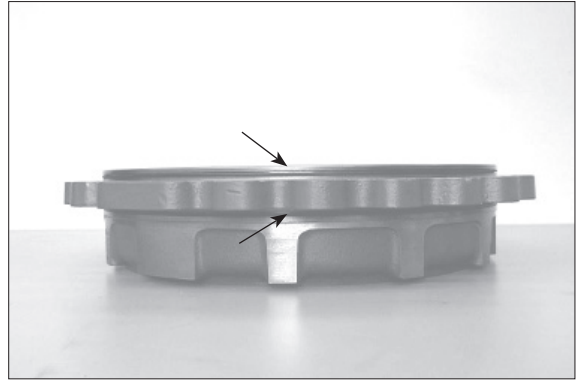

7577AAXF017

(17) Remove O-ring (see arrow) from the recess of the brake housing.

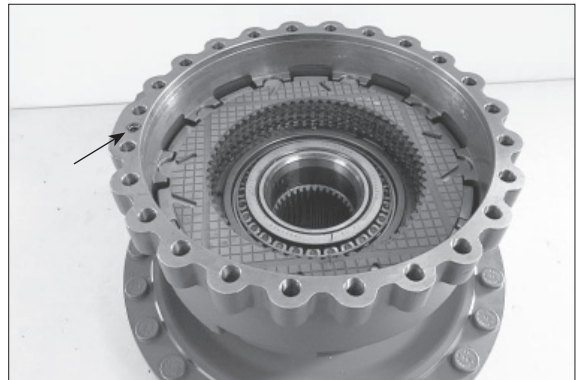

7577AAXF018

(18) Take the disc pack out of the brake housing.

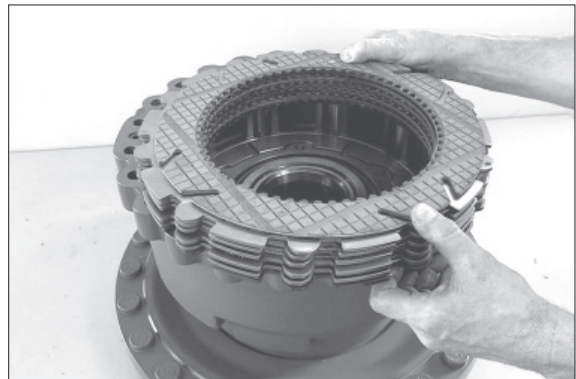

7577AAXF019

(19) Install slotted pins (6EA) in the support shim until they are flush-mounted.

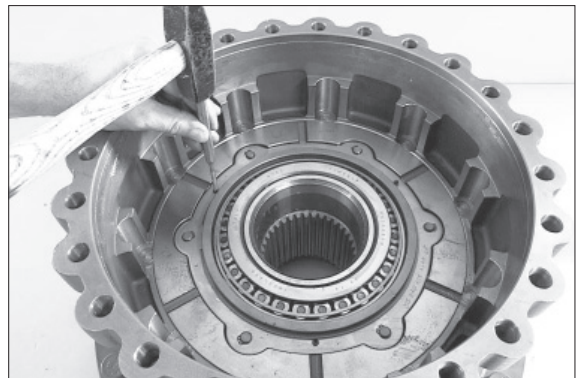

7577AAXF020

(20) Squeeze out the circlip.

※ Special tool

Set of external pliers

5870 900 016

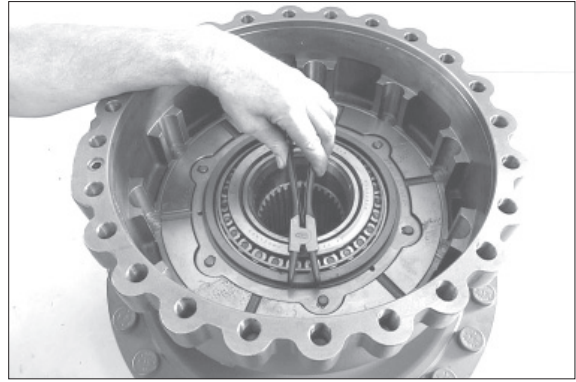

7577AAXF021

(21) Press piston out of the brake housing by means of compressed air.



7577AAXF022

(22) Press support shim out of the piston by means of the automatic piston adjusting.

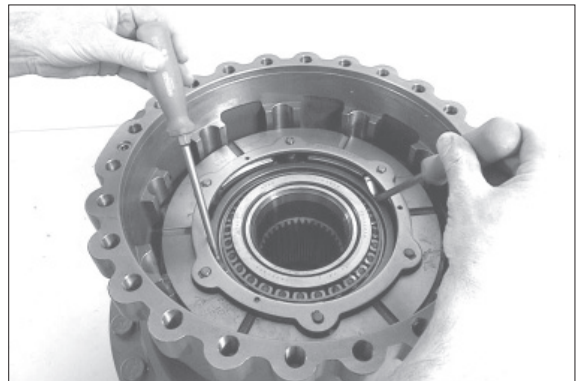

7577AAXF023

(23) Drive slotted pins (6EA) out of the support shim.

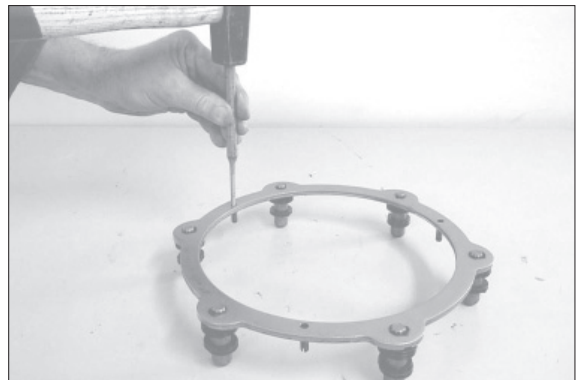

7577AAXF024

(24) Preload the cup springs by means of the press and unsnap the circlip.

※ Special tool

Assembly pliers 5870 900 051

Assembly fixture 5870 345 096

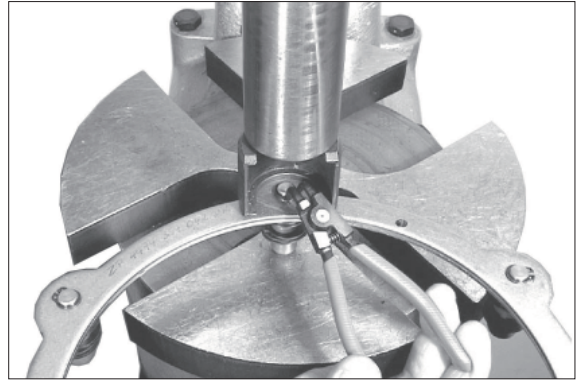

7577AAXF025

(25) Pull pin out of the support shim and remove released cup springs.



7577AAXF026

(26) Press gripping rings from the pin.

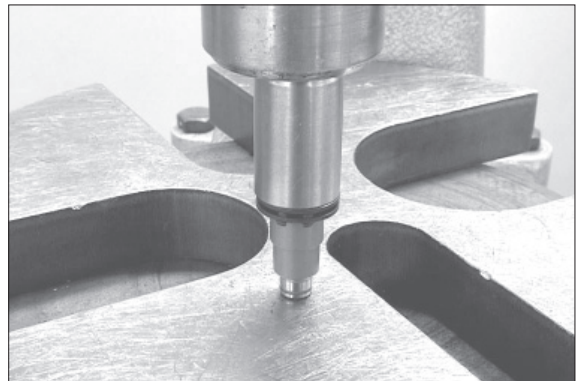

7577AAXF027

(27) Lift piston out of the brake housing.

※ Special tool

Adjusting device 5870 400 001

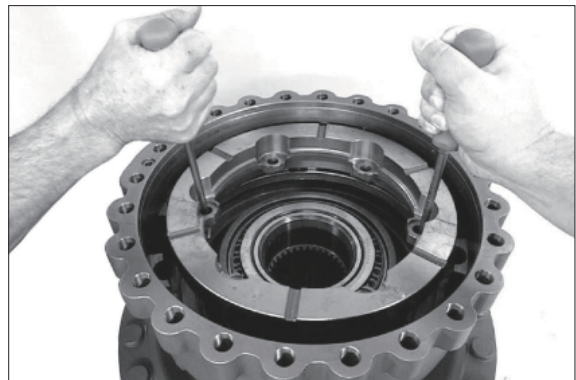

7577AAXF028

(28) Remove guide ring, support rings and U-rings from the annular grooves of the brake housing.

※ See below sketch for installation position of the single parts.

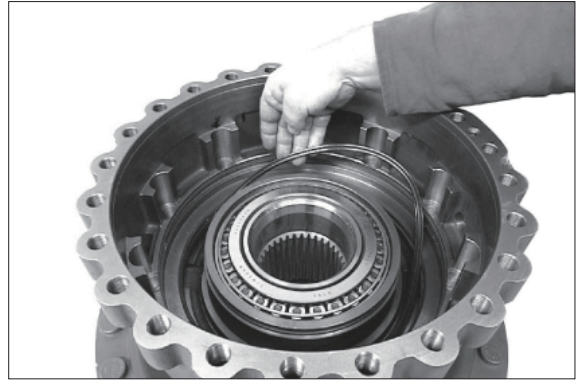

7577AAXF029

To the sketch :

- 1 Brake housing
- 2 Guide ring
- 3 Support ring
- 4 U-ring
- 5 U-ring
- 6 Support ring
- 7 Output shaft

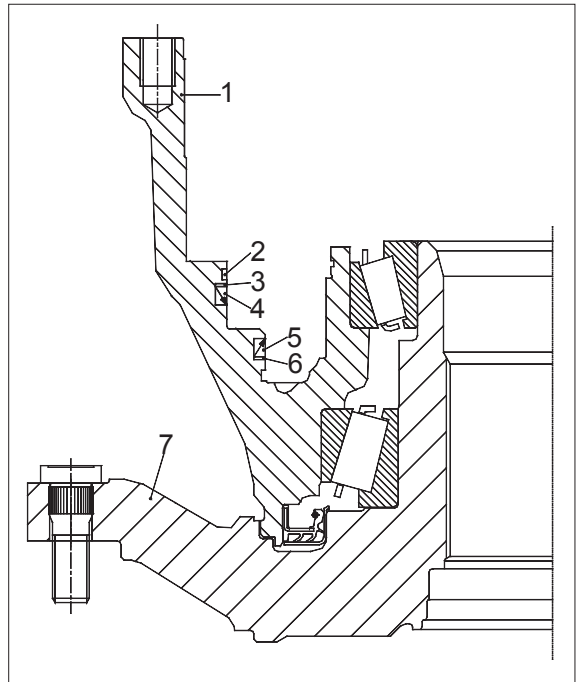

7577AAXF030

(29) Pull brake housing by means of two-armed puller from the output shaft and remove the released bearing inner ring.

※ Special tool

- | | |
|------------------|--------------|
| Two-armed puller | 5870 970 007 |
| Clamping bracket | 5870 654 034 |
| Press bush | 5870 506 140 |



7577AAXF031

(30) Lift brake housing with lifting tackle from the output shaft.

※ Special tool

Lifting chain 5870 281 047

Eye bolts 5870 204 071

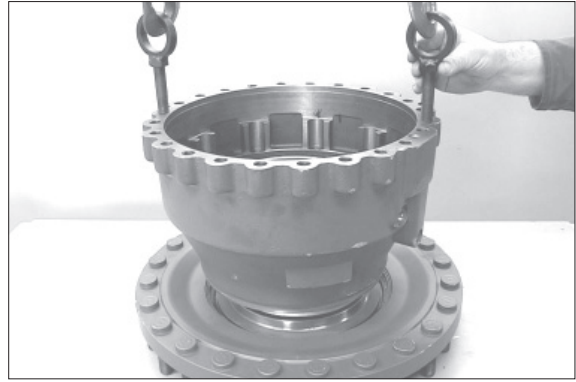

7577AAXF032

(31) If necessary drive both bearing outer rings out of the bearing bores in the brake housing.



7577AAXF033

(32) Press shaft seal out of the brake housing.

※ Special tool

Pry bar set 5870 345 065



7577AAXF034

(33) Pull bearing inner ring from the output shaft.

※ Special tool

Rapid grip 5873 014 011

Basic set 5873 004 001

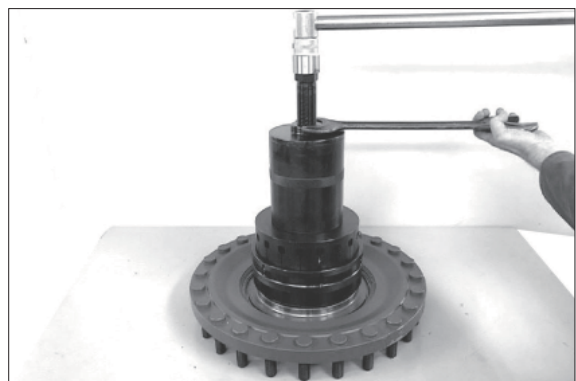

7577AAXF035

(34) Press off bearing sheet from the output shaft.

※ Special tool
Pry bar set

5870 345 065

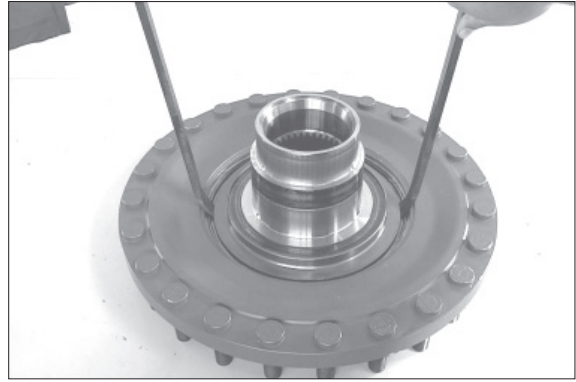

7577AAXF036

2) REASSEMBLY OF OUTPUT AND BRAKE

(1) Insert wheel bolt into the output shaft until contact.

※ Special tool

Wheel bolt puller-basic set 5870 610 010

Insert (7/8"-14 UNF) 5870 610 011

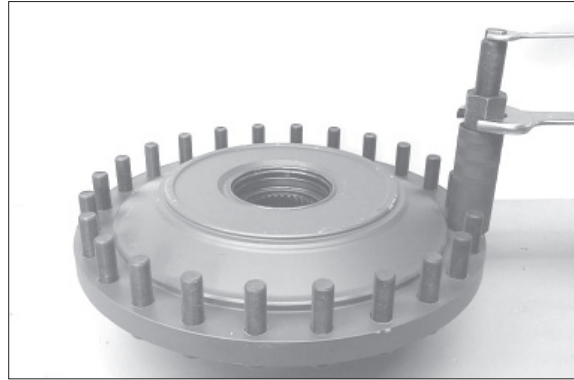

7577AAXF037

(2) Assemble bearing sheet (shaft seal).

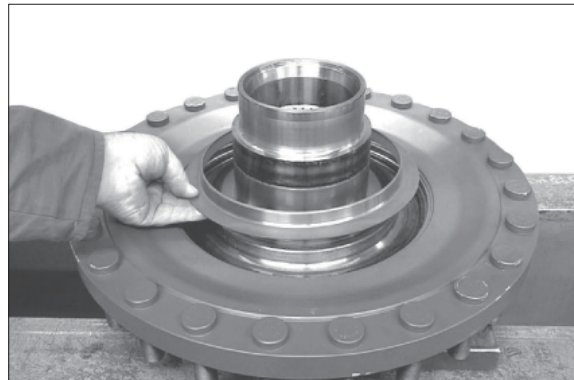

7577AAXF038

(3) Press bearing sheet over the collar of the output shaft.

※ Special tool

Pressure ring 5870 506 141

※ The exact installation position of the bearing sheet will be obtained by using the specified pressure ring.

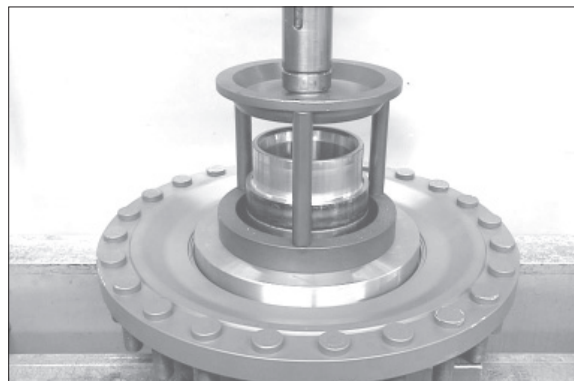

7577AAXF039

(4) Heat the roller bearing and install it until contact.

※ After cooling-down the bearing has to be installed subsequently.



7577AAXF040

- (5) Press both bearing outer rings into the brake housing until contact.

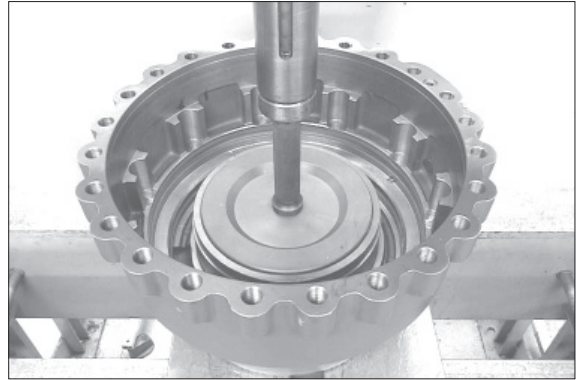

7577AAXF041

- (6) Install shaft seal with the sealing lip showing to the oil chamber (see below sketch).

- ※ Special tool
Driver 5870 051 052
- ※ The exact installation position of the shaft seal will be obtained by using the specified driver.

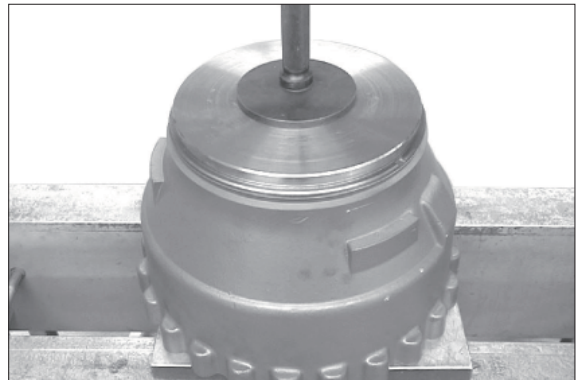

7577AAXF042

- ▲ Just before the installation wet the outer diameter of the shaft seal with spirit.**

To the sketch :

- 1 Brake housing
- 2 Shaft seal
- * Grease filling

- ※ Fill the space between sealing and dust lips with grease.

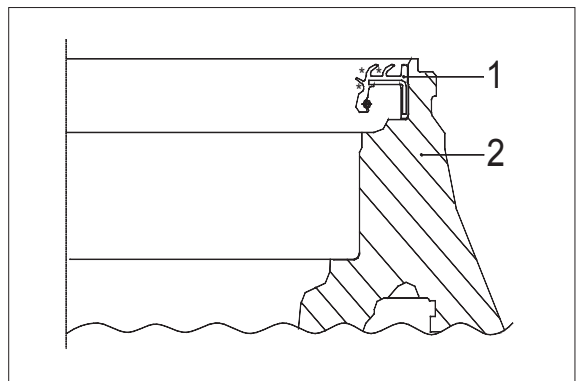

7577AAXF043

- (7) Install the preassembled brake housing by means of the lifting tackle over the output shaft until contact.

- ※ Special tool
Lifting chain 5870 281 047
Eye bolts 5870 204 071



7577AAXF044

(8) Heat the roller bearing and install it until contact.

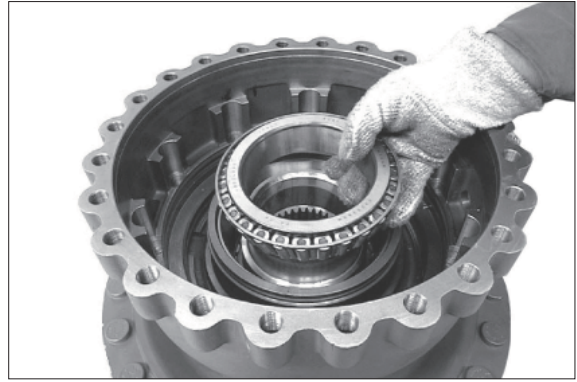

7577AAXF045

(9) Insert support and U-rings into the annular grooves of the brake housing.

※ Pay attention to the installation position, see below sketch.

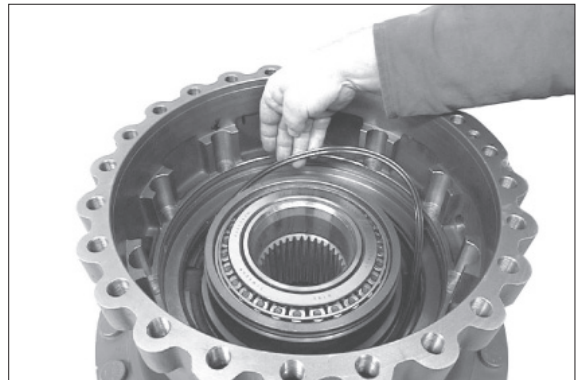

7577AAXF046

To the sketch :

- 1 Brake housing
- 2 Guide ring
- 3 Support ring
- 4 U-ring
- 5 U-ring
- 6 Support ring
- 7 Output shaft

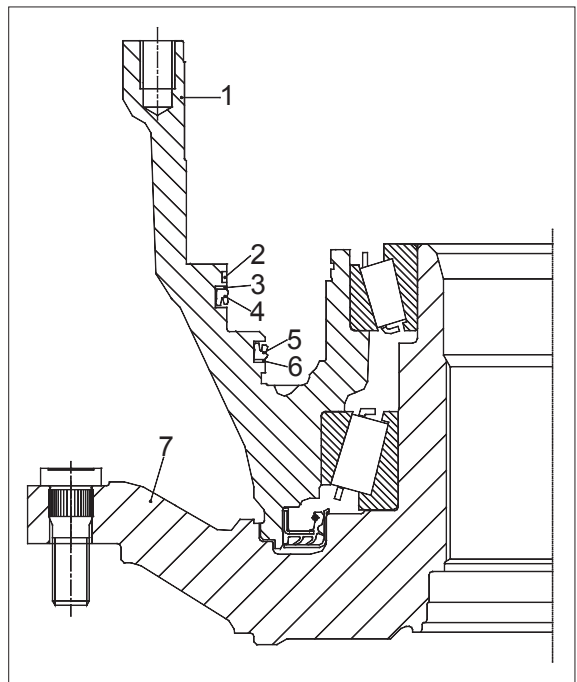

7577AAXF047

(10) Clean annular groove of the brake housing with spirit.

Then insert the guide ring into the annular groove (also see sketch page 3-188) and fix it with Loctite (type No. 415) at its extremities.

※ Guide ring must have contact on the whole circumference.

▲ Upon installation the orifice of the guide ring must show upwards (12 o'clock).

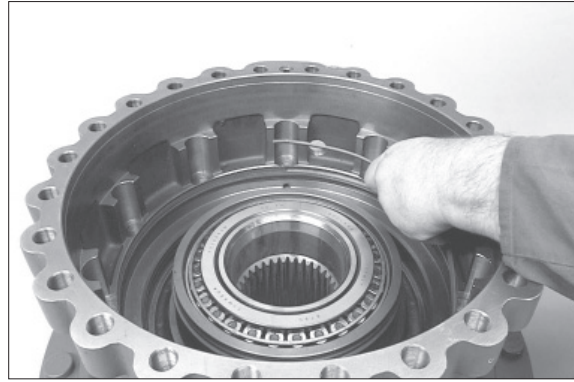

7577AAXF048

(11) Insert piston into the brake housing and install it cautiously until contact.

※ Apply sufficiently oil on the sliding surface of the piston or support rings, U-rings and guide ring (use W-10 oils).

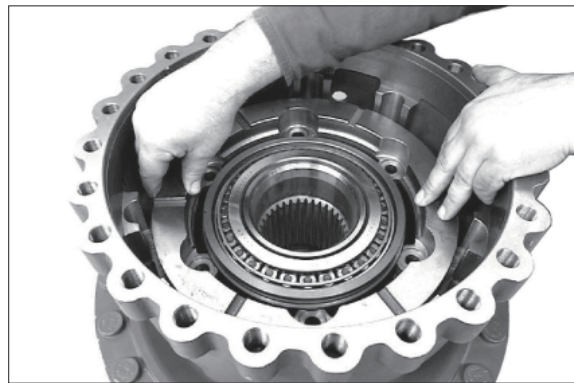

7577AAXF049

(12) Insert pins into the assembly fixture until contact.

※ Special tool

Assembly fixture 5870 345 096

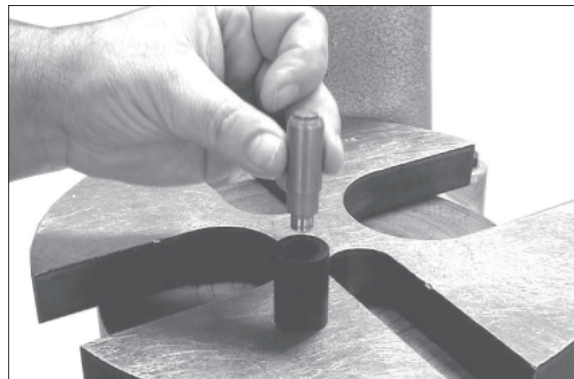

7577AAXF050

(13) Press gripping rings (4EA, see arrows) onto the pins until contact on the assembly fixture.

※ The exact installation dimension (see sketch page 3-190) of the gripping rings is obtained when using the specified assembly fixture.

▲ Observe the installation position, install gripping rings with the orifices offset by 180° to each other.

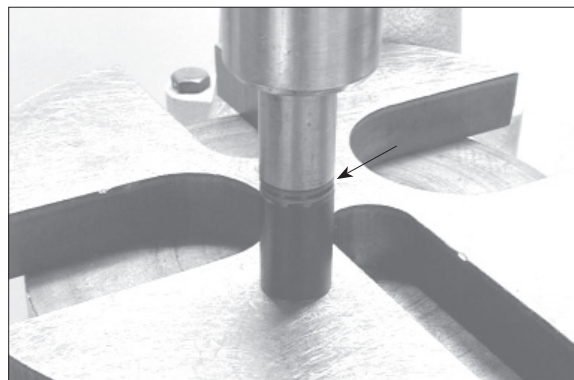

7577AAXF051

(14) Install cup springs (7 pieces each/pin).

- ※ Pay attention to the installation position of the cup springs, see below sketch.



7577AAXF052

To the sketch :

- 1 Pin
- 2 Gripping rings
- 3 Cup springs
- 4 Support shim
- 5 Circlip
- X Installation dimension gripping rings
 10.5 ± 0.3 mm

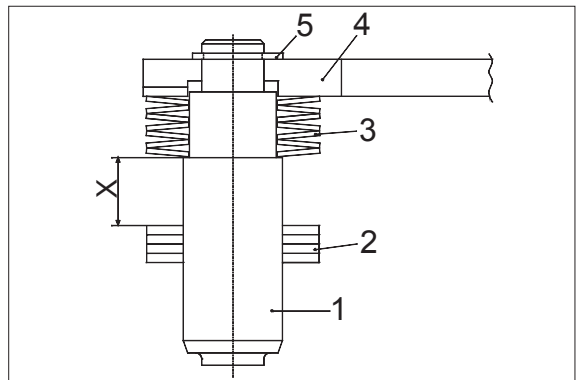

7577AAXF053

(15) Insert preassembled pins into the support shim and fix it by means of the circlip.

- ※ Special tool
Assembly pliers 5870 900 051
- ※ Pay attention to clearance of the cup springs.

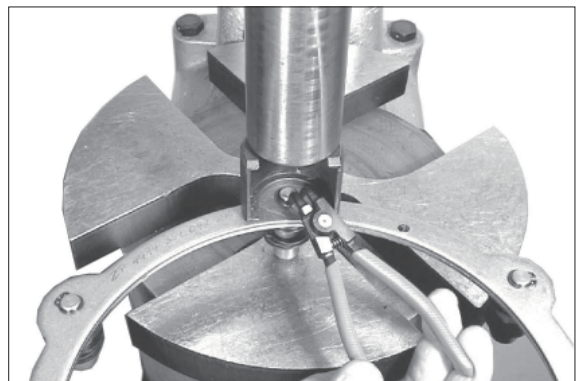

7577AAXF054

(16) Insert preassembled support shim into the piston.

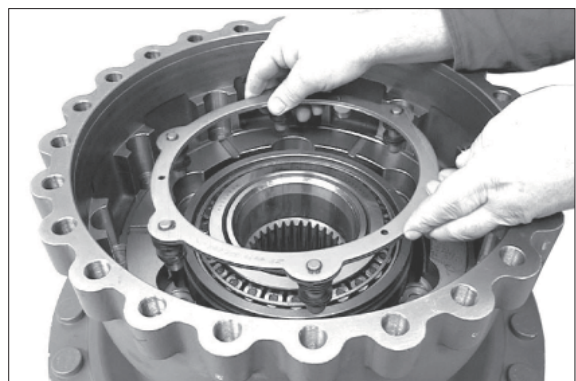

7577AAXF055

(17) Fix support shim by means of the circlip.

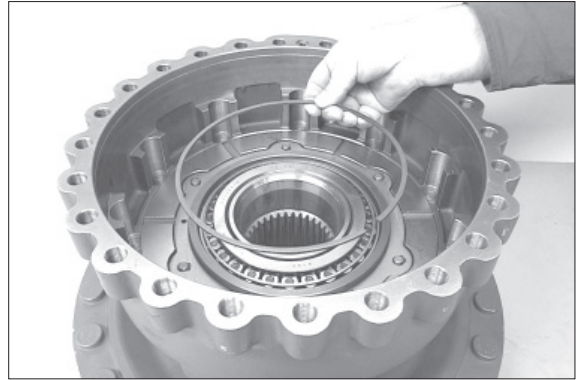

7577AAXF056

(18) Drive slotted pins (6EA) into the bores of the support shim to lock the circlip.

- ※ Special tool
Drive mandrel 5870 705 011
- ※ Pay attention to the installation position, see below sketch.

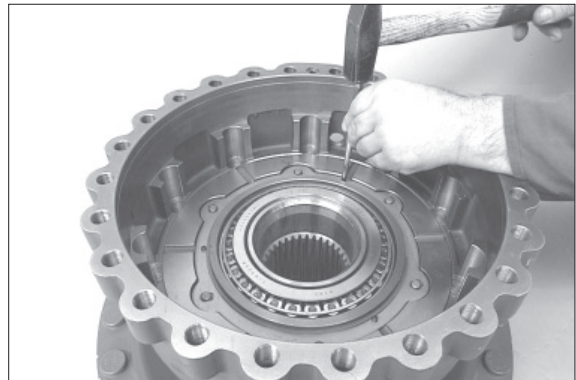

7577AAXF057

To the sketch :

- 1 Brake housing
- 2 Circlip
- 3 Slotted pin
- 4 Support shim
- 5 Piston
- X Installation dimension $4.0_{-0,5}$ mm

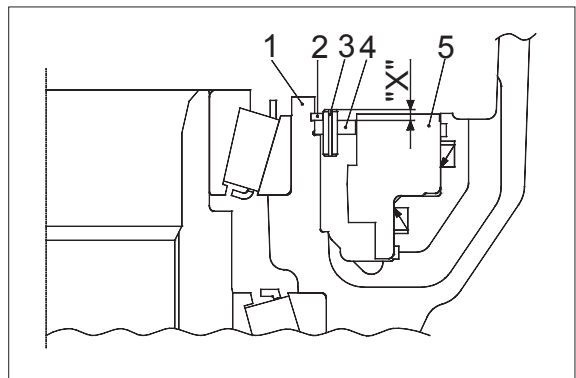

7577AAXF058

(19) Drive stop bolt into the planet carrier until contact.

Then wet spline (see arrow).

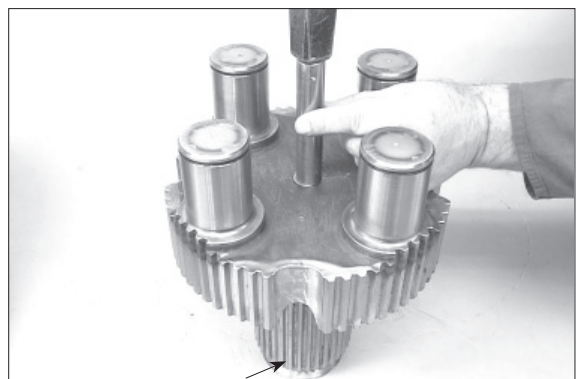

7577AAXF059

(20) Insert planet carrier into the spline of the output shaft until contact.

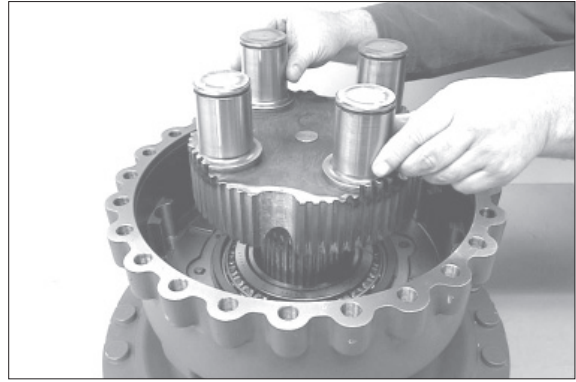

7577AAXF060

(21) Mount outer and inner disks (lining disks with paper or sinter lining).

※ Quantity and arrangement of the disks please take from the related parts list.

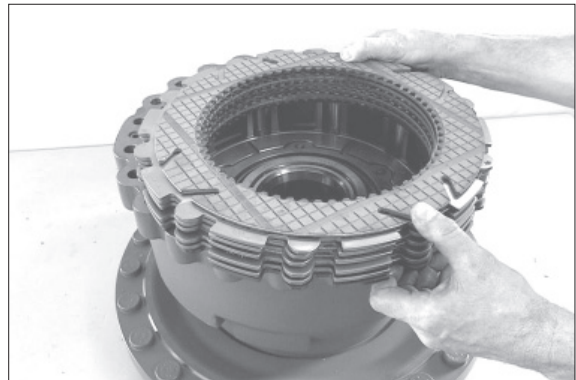

7577AAXF061

(22) Insert O-ring (see arrow) into the recess of the brake housing.

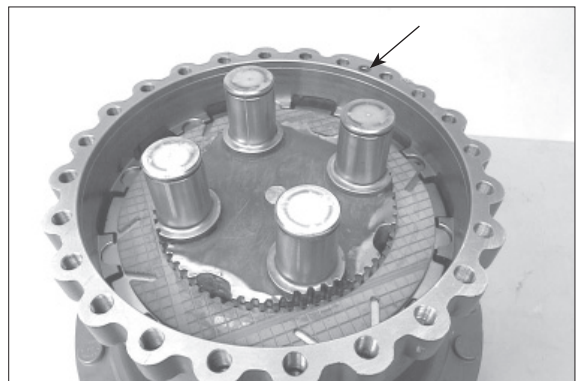

7577AAXF062

(23) Grease both O-rings (see arrows) and insert them into the annular grooves of the ring gear.

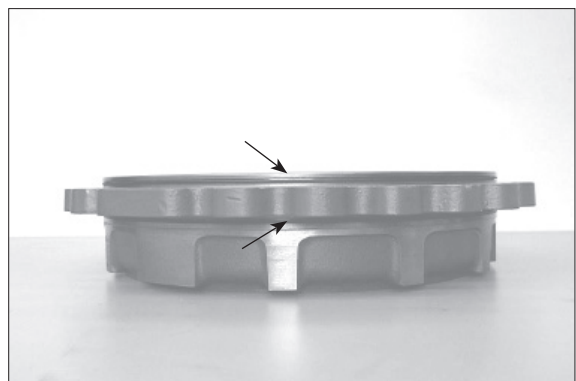

7577AAXF017

(24) Install two adjusting screws and insert ring gear into the brake housing until contact.

- ※ Special tool
Adjusting screws 5870 204 029
- ※ Pay attention to radial location.

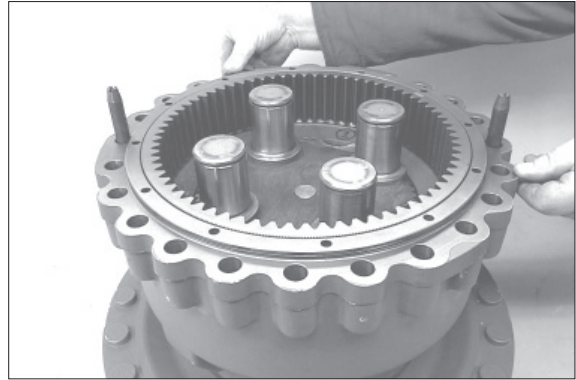

7577AAXF063

(25) Heat bearing inner rings and install them until contact with the big radius showing to the planet carrier (downwards).

- ※ Subsequently install bearing inner rings after cooling down.

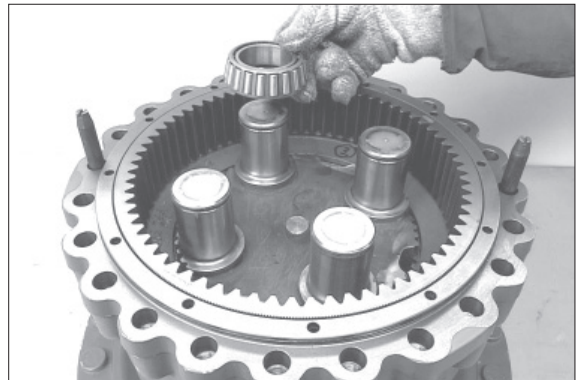

7577AAXF064

(26) Put planet gears onto the bearing inner rings.

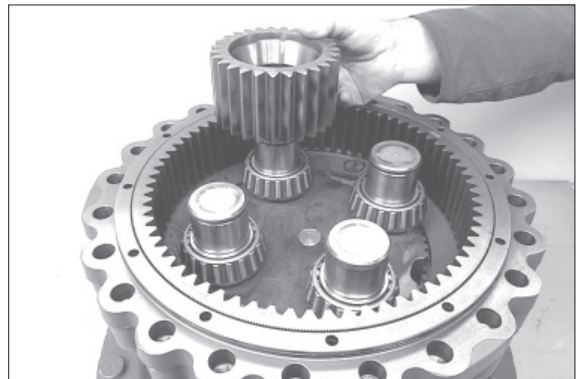

7577AAXF065

(27) Heat bearing inner rings and install them on the planet gears until contact.

- ※ Subsequently install bearing inner rings after cooling down.



7577AAXF066

(28) Fasten plant gears by means of retaining rings.

- ※ Special tool
- Set of external pliers 5870 900 015

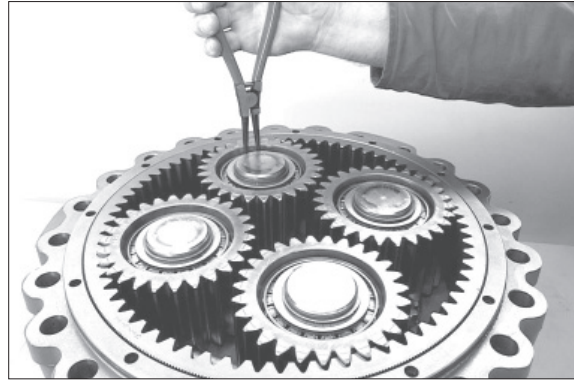

7577AAXF067

Adjust end play of sun gear shaft 0.5 ~ 2.0 mm

(29) Fasten ring gear by means of cap screws until contact.

Then determine dimension I, from the mounting face of the ring gear up to the face of the stop bolt.

Dimension I e.g 67.90 mm

- ※ Special tool
- Digital depth gauge 5870 200 072
- Gauge blocks 5870 200 066
- Straightedge 5870 200 022

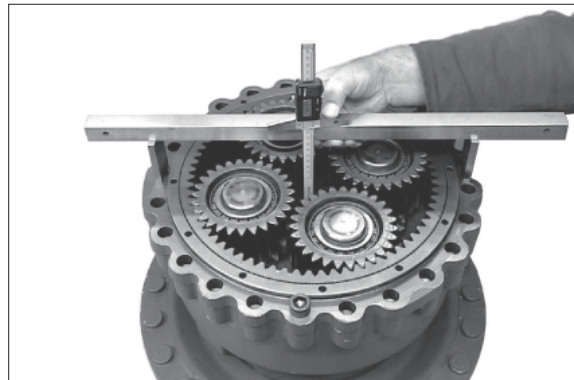

7577AAXF068

(30) Insert stub shaft into spline of the axle bevel gear until contact.

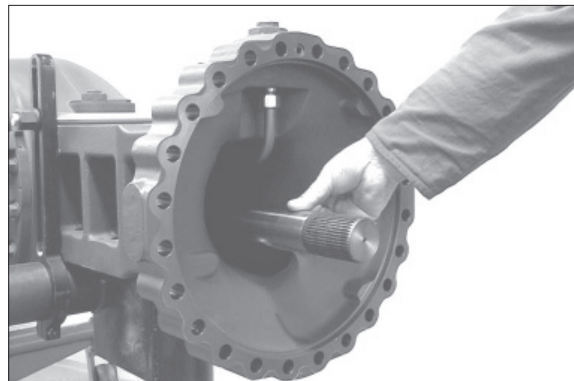

7577AAXF069

(31) Assemble sun gear shaft until contact.

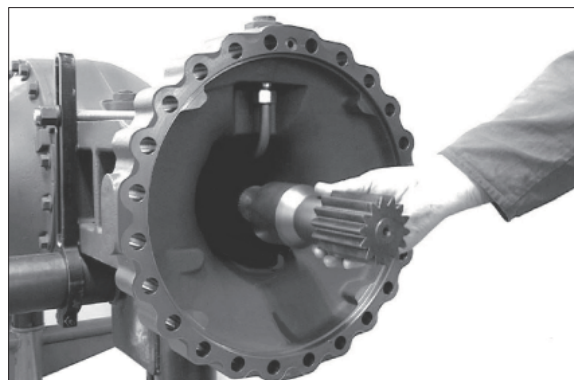

7577AAXF070

(32) Determine Dimension II from the face of the sun gear shaft up to the mounting face of the axle casing.

Dimension II e.g. 63.00 mm

※ Special tool

Digital depth gauge 5870 200 072

Gauge blocks 5870 200 066

Straightedge 5870 200 022

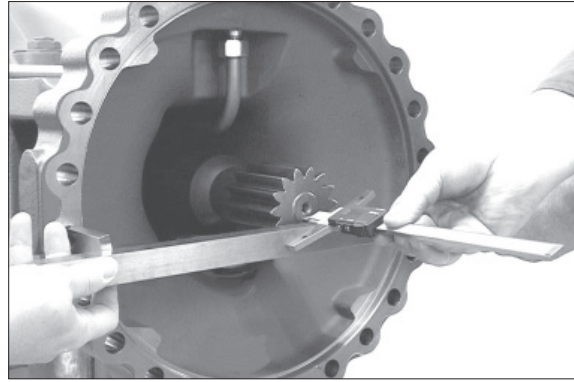

7577AAXF071

EXAMPLE A :

Dimension I 67.90 mm

Dimension II - 63.00 mm

Difference 4.90 mm

required end play e.g. - 1.10 mm

Difference = shim e.g. s = 3.80 mm

(33) Insert sun gear shaft into the planet carrier.

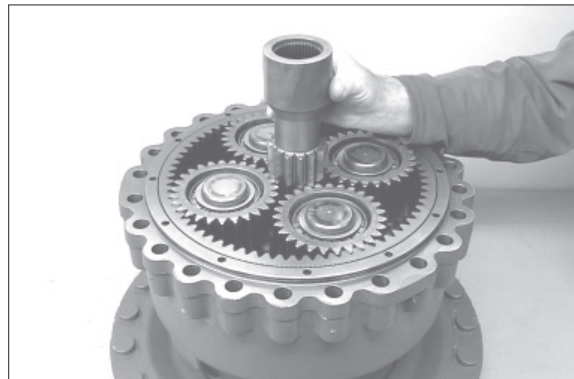

7577AAXF072

(34) Fix determined shim (s), e.g. s = 3.80 mm, into the sun gear shaft by means of grease.

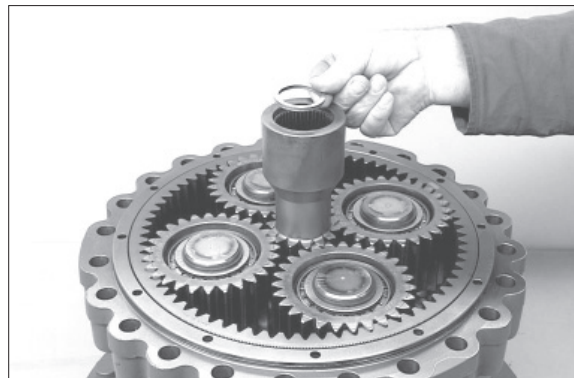

7577AAXF073

(35) Fix O-ring (see arrow) into the recess of the axle casing by means of grease and install the preassembled output to the axle casing until contact by means of lifting tackle.

※ Special tool

Lifting bracket 5870 281 043

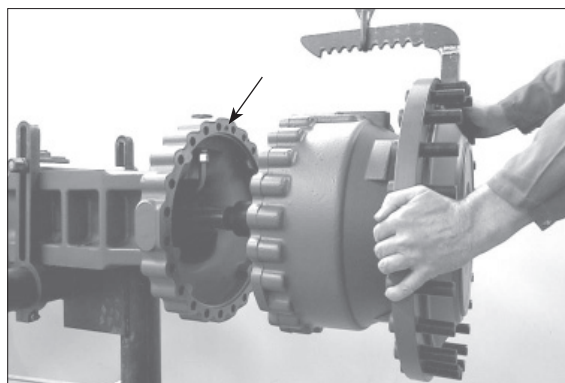

7577AAXF074

(36) Fasten output by means of hexagon screws and washers.

· Tightening torque (M18/10.9) :

39.8 kgf · m (288 lbf · ft)

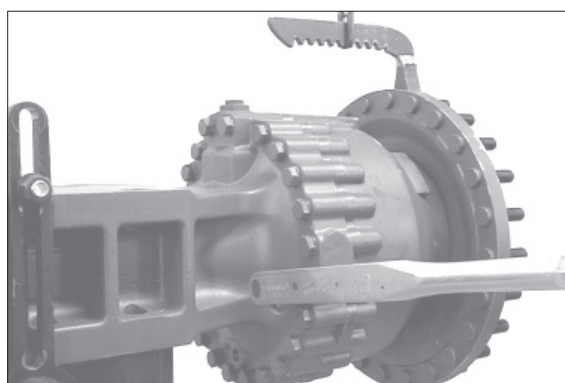

7577AAXF075

(37) Unscrew slotted nut by hand and then fasten it.

· Tightening torque : $153^{+20.4}$ kgf · m
(1107^{+148} lbf · ft)

※ Special tool

Socket spanner 5870 656 078

Centering bracket 5870 912 028

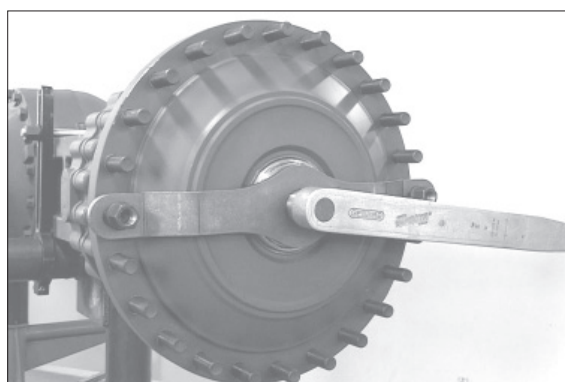

7577AAXF076

(38) Secure slotted nut by means of slotted pin.



7577AAXF077

(39) Assemble O-ring (see arrow) to the cover.



7577AAXF078

(40) Insert cover into the output shaft until contact.

※ Special tool

Hammer (plastic \varnothing 60) 5870 280 004



7577AAXF079

Leakage test of the brake hydraulics

※ Prior to start the test, ventilate the brake hydraulics completely.

- 1) Open the bleeder.
- 2) Slowly actuate the HP-pump until oil flows out of the bleeder.
- 3) Close the bleeder again.
- 4) Slowly pressurize the HP-pump with $p > 10$ bar and hold the pressure for some seconds.

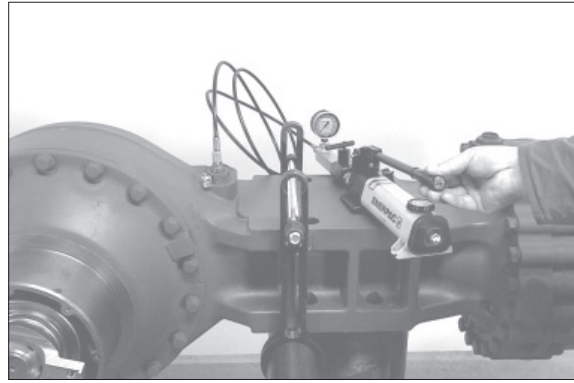

※ The brake piston extends and the cylinder chamber fills up with oil. The air accumulates in the upper section of the cylinder chamber.

- 5) Loosen the shut-off valve on the HP-pump.

※ The reversing piston presses the air from the upper section of the cylinder into the brake line.

- 6) Open the bleeder again.
- 7) Slowly actuate the HP-pump until oil flows out of the bleeder.

※ Repeat procedure - Item 3)~7) until at 7) from the beginning of the actuation no more air exits from bleeder.

※ Then pressurize the brake temporarily (5EA) with $p = 100$ bar max.

High-pressure test :

Increase test pressure up to $p = 100_{.10}$ bar and close connection to HP-pump by means of shut-off valve.

During a 5 min. testing time a pressure drop of max. 2% (2 bar) is allowed.

▲ If the maximum pressure of 100 bar is exceeded, there will be an excessive piston adjustment and a repeated disassembly of the brake or the adjusting is required to reset the gripping rings to the adjusting dimension.

Low-pressure test :

Reduce test pressure to $p = 5$ bar and close the shut-off valve again.

During a 5 min. testing time a pressure drop is not allowed.

※ Special tool

HP-Pump 5870 287 007

Mini-measuring hub 5870 950 115
(9/16"- 18UNF)

※ Prior to putting the axle into operation, fill in the oil acc. to the lubrication and maintenance instructions.

3) DISASSEMBLY OF DIFFERENTIAL CARRIER AND OIL PIPES

(1) Disassembly of differential carrier

① Fasten axle on assembly truck.

※ Special tool

Assembly truck 5870 350 000

Holding fixtures 5870 350 077

Clamps 5870 350 075

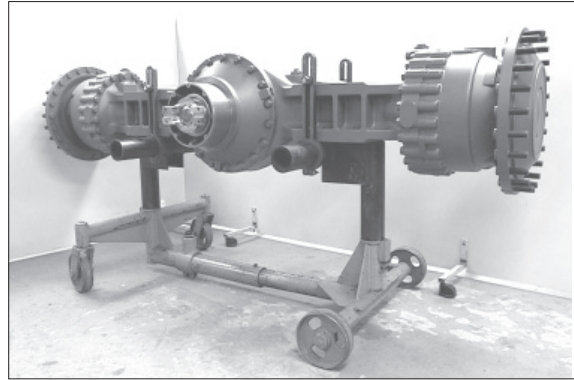

7577AAXF001

② Loosen screw plugs (3EA, see Figure 7577AAXF002 and 003) and drain oil from axle casing.

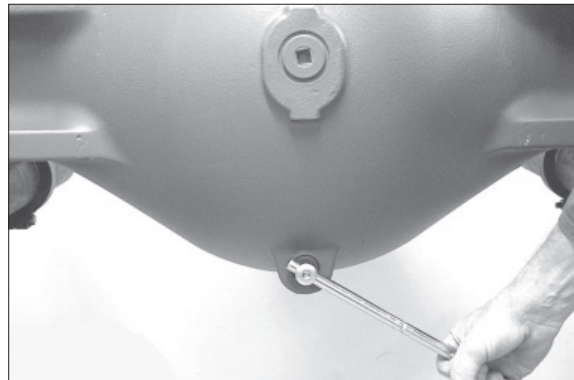

7577AAXF002

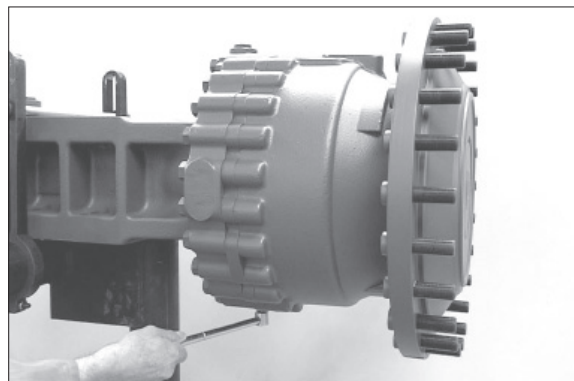

7577AAXF003

③ Secure output by means of lifting tackle and loosen hexagon screws.

※ Special tool

Lifting bracket 5870 281 043

※ Make step (Fig. 7577AAXF007~9) on both output sides.

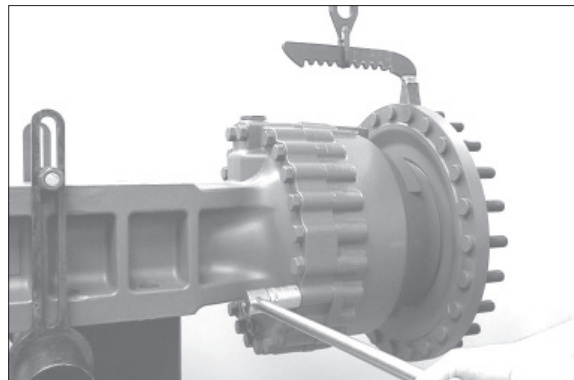

7577AAXF007

④ Separate complete output from the axle casing.

※ Pay attention to released O-ring (see arrow).

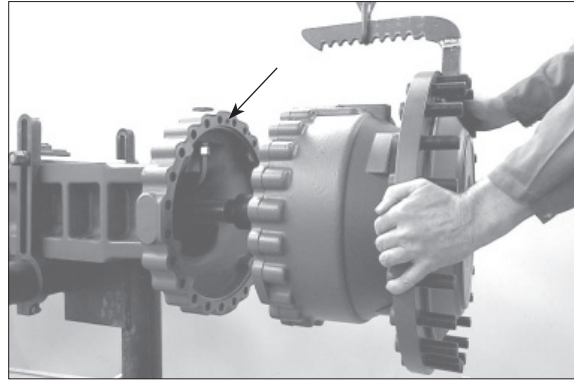

7577AAXF008

⑤ Pull stub shaft out of the sun gear shaft.

※ Pay attention to released shim (s).

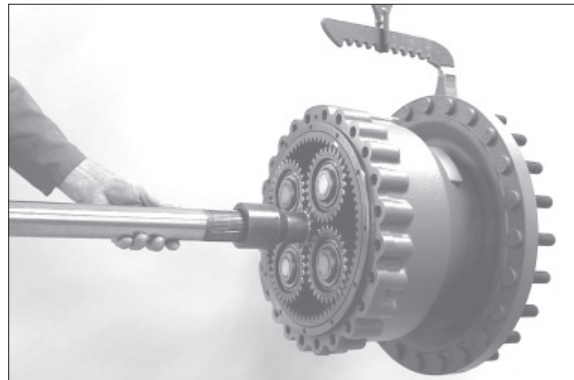

7577AAXF009

⑥ Loosen hexagon screws.

※ Mark location of differential carrier to the axle casing (see arrows).

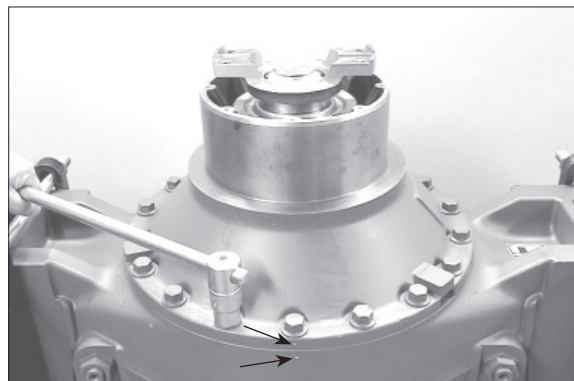

7577AAXF081

⑦ Lift differential carrier by means of lifting tackle out of the axle casing.

※ Special tool

Lifting tackle

5870 281 044

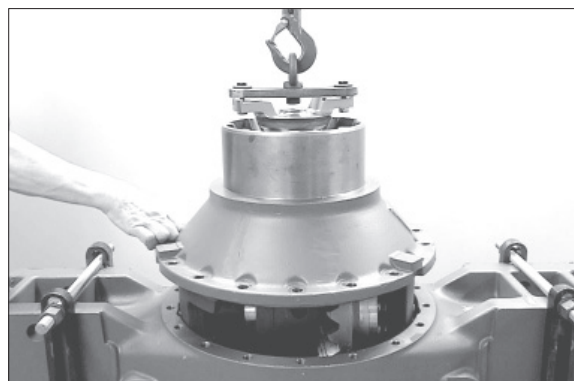

7577AAXF082

⑧ Fasten differential carrier to assembly truck.

※ Special tool

Assembly truck 5870 350 000

Holding fixture 5870 350 034

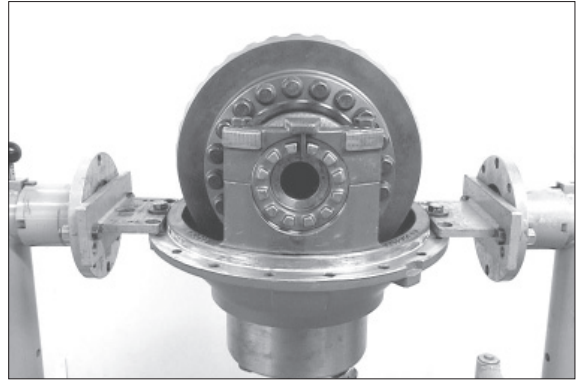

7577AAXF083

⑨ Drive out slotted pins.

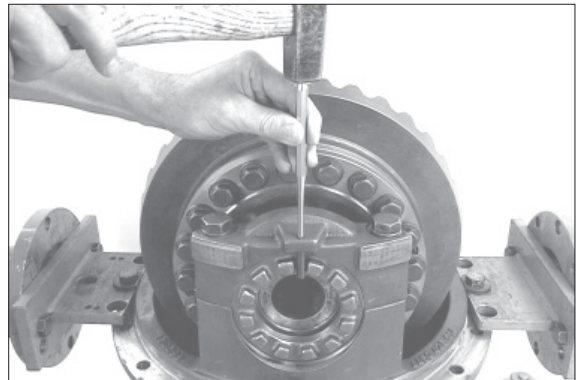

7577AAXF084

⑩ Loosen and remove both adjusting nuts.

※ Special tool

Socket spanner 5870 656 079

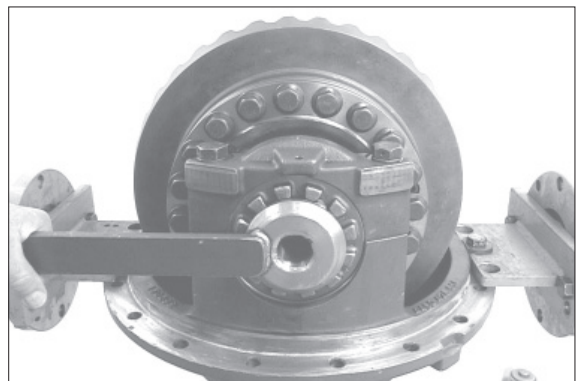

7577AAXF085

⑪ Heat axle drive housing by means of hot-air blower.

※ Special tool

Hot-air blower 230 V 5870 221 500

Hot-air blower 115 V 5870 221 501

※ Hexagon screws are installed with Loctite (type No. 262).



7577AAXF086

⑫ Loosen hexagon screws and take off bearing bracket.

▲ Loosen hexagon screws by hand only.

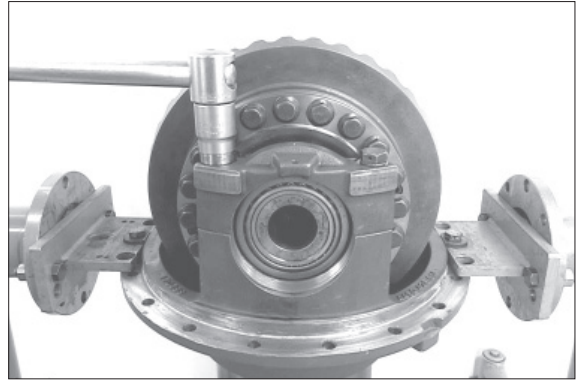

7577AAXF087

⑬ Remove both bearing outer rings.

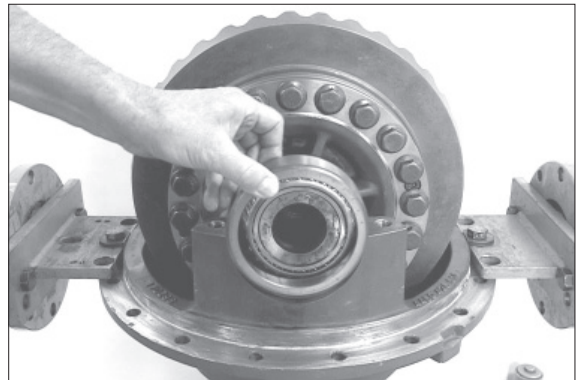

7577AAXF088

⑭ Lift differential out of the housing by means of lifting tackle.

※ Special tool
Lifting tackle 5870 281 013

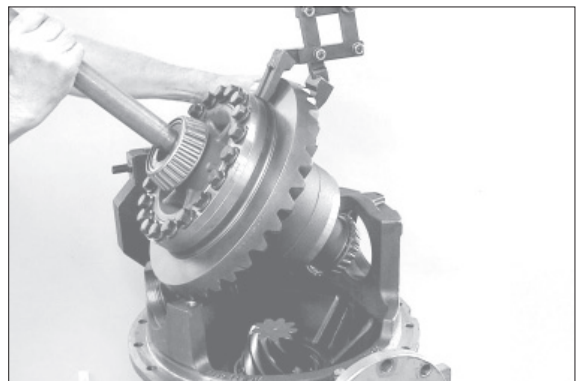

7577AAXF089

Disassembly of limited slip differential

⑮ Pull bearing inner ring from the differential housing.

※ Special tool
Gripping insert 5873 002 027
Basic set 5873 002 001

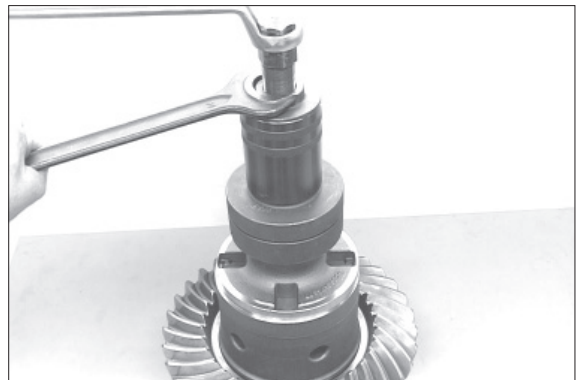

7577AAXF090

- ⑩ Pull bearing inner ring from the housing cover.

※ Special tool

Rapid grip

5873 012 017

Basic set

5873 002 001

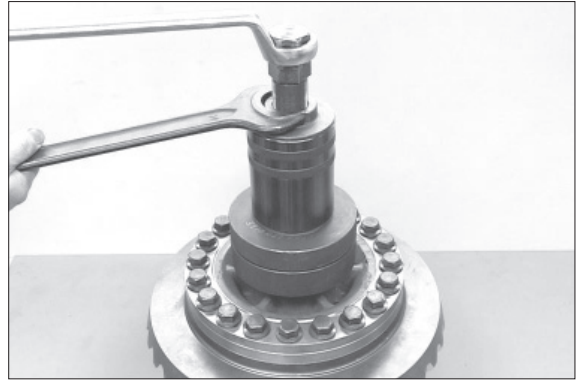

7577AAXF091

- ⑪ Fasten differential by means of press and loosen locking screws.

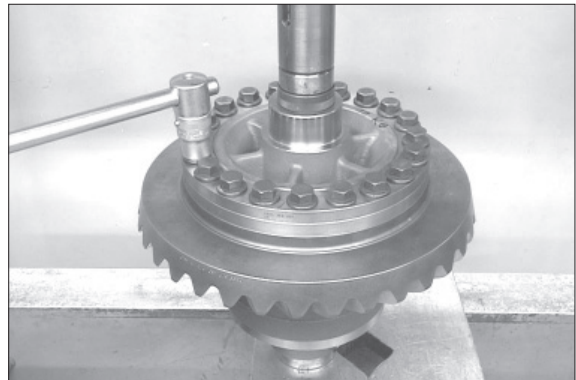

7577AAXF092

- ⑫ Loosen cap screws and remove released housing cover.

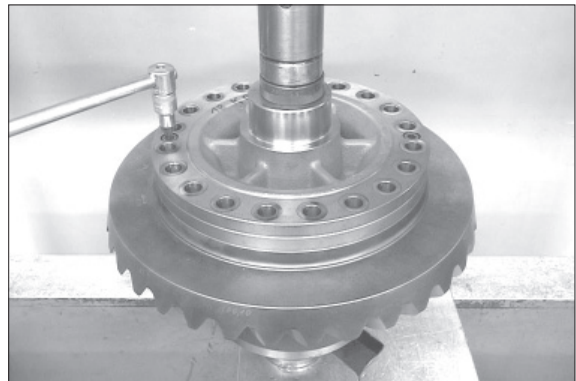

7707AAXR001

- ⑬ Remove all single parts from the differential housing.

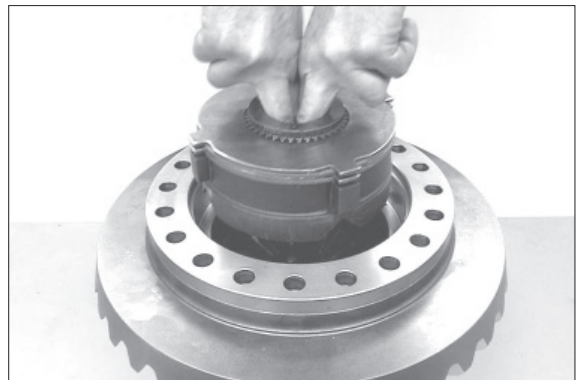

7577AAXF093

- ⑳ Press off crown wheel from the differential housing.

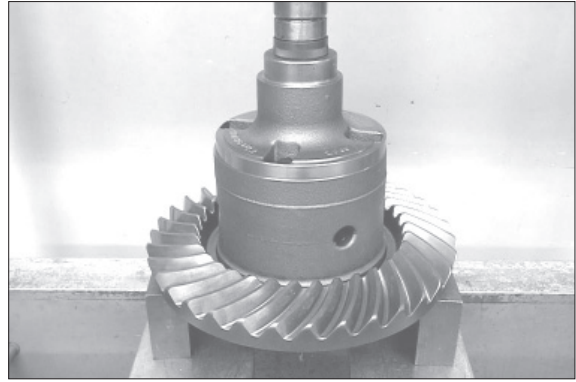

7577AAXF094

Disassembly of drive pinion

- ㉑ Heat slotted nut by means of hot-air blower.

※ Special tool

Hot-air blower 230 V 5870 221 500

Hot-air blower 115 V 5870 221 501

※ Slotted nut is locked with Loctite (type No. 262).

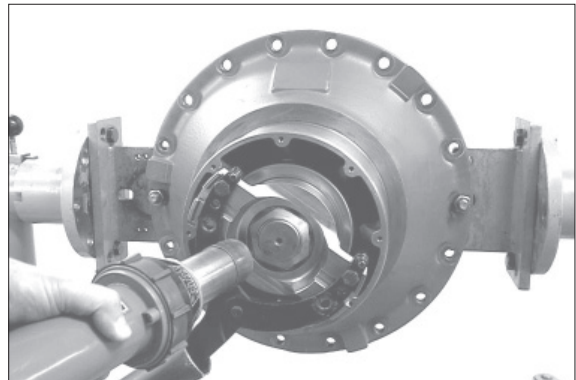

7577AAXF095

- ㉒ Loosen slotted nut and remove the washer behind it.

※ Special tool

Slotted nut wrench 5870 401 139

Fixture 5870 240 002

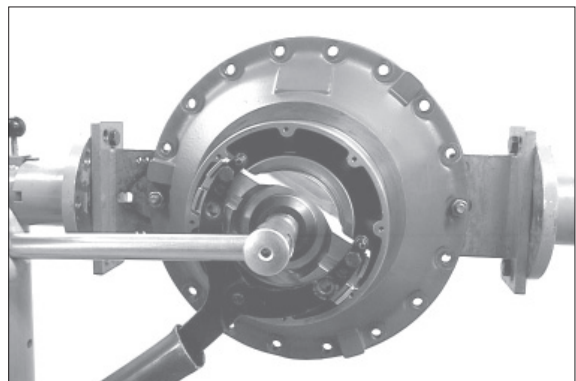

7577AAXF096

- ㉓ Pull input flange from the drive pinion.

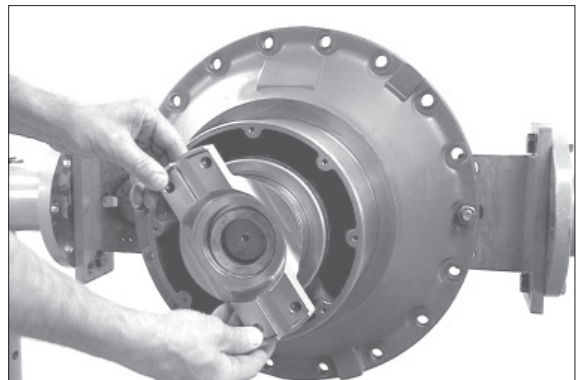

7577AAXF097

- ②④ Press shaft seal out of the axle drive housing.

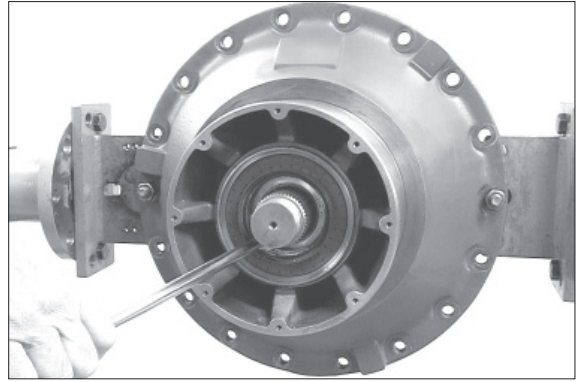

7577AAXF098

- ②⑤ Press drive pinion out of the axle drive housing by means of two-armed puller and remove the released bearing inner ring.

- ※ Special tool
Two-armed puller 5870 970 007

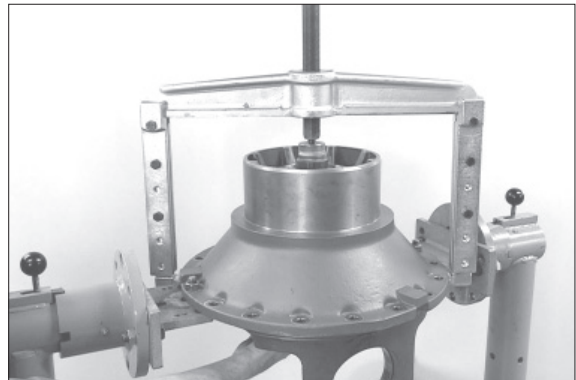

7577AAXF099

- ②⑥ Take off spacer ring and pull bearing inner ring from the drive pinion.

- ※ Special tool
Gripping insert 5873 002 030
Basic set 5873 002 001

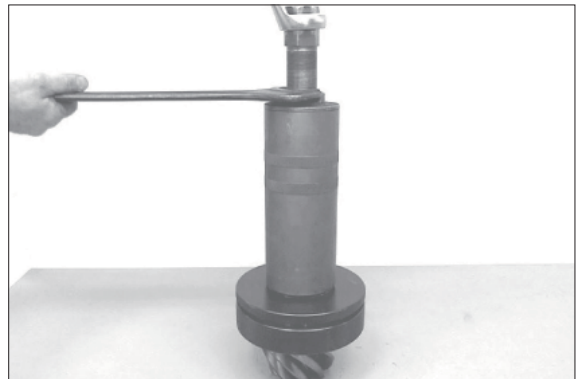

7577AAXF100

- ②⑦ If necessary drive out both bearing outer rings from the axle drive housing.

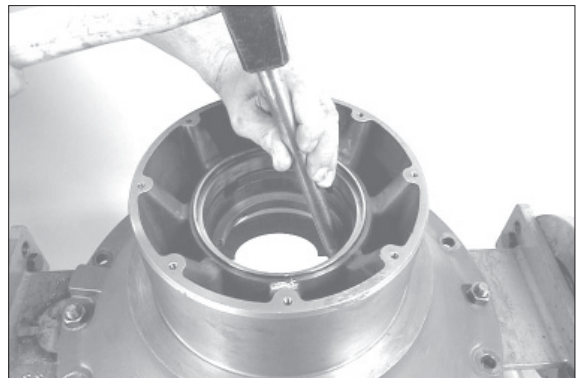

7577AAXF101

(2) Disassembly of brake tubes

- ① Loosen hexagon nut.

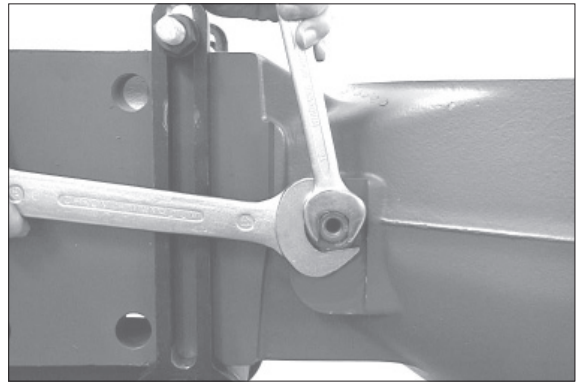

7577AAXF103

- ② Loosen union screw.

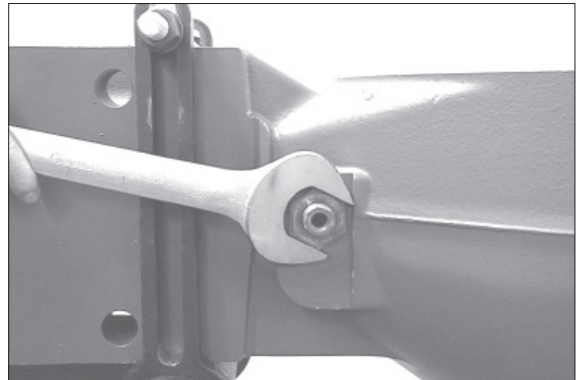

7577AAXF104

- ③ Loosen pipe union and remove released brake tube from the axle casing.

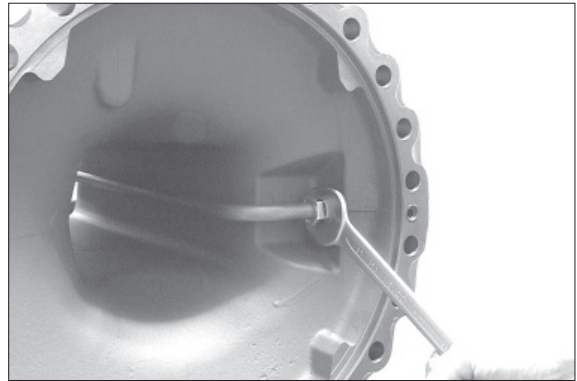

7577AAXF105

- ④ Remove vent valve from the connection part.

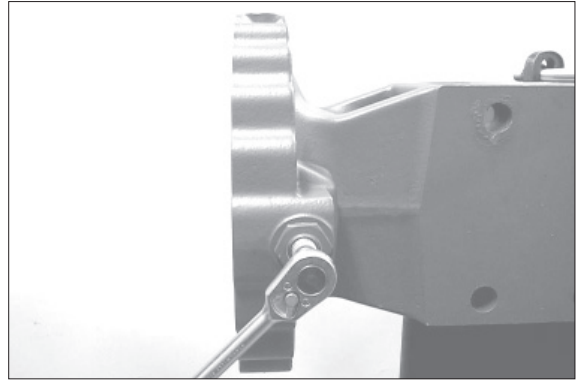

7577AAXF106

- ⑤ Loosen connection part and remove it from the axle casing.

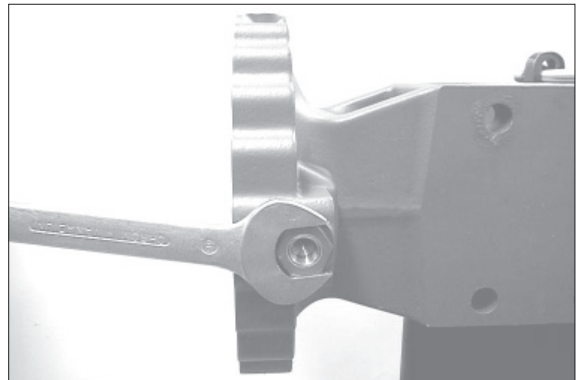

7577AAXF107

4) REASSEMBLY OF BRAKE TUBES AND DIFFERENTIAL CARRIER

(1) Reassembly of brake tubes

① Preassemble connection part as shown in opposite figure.

- 1 Vent valve
- 2 Connection part
- 3 O-Ring
- 4 Rectangular ring

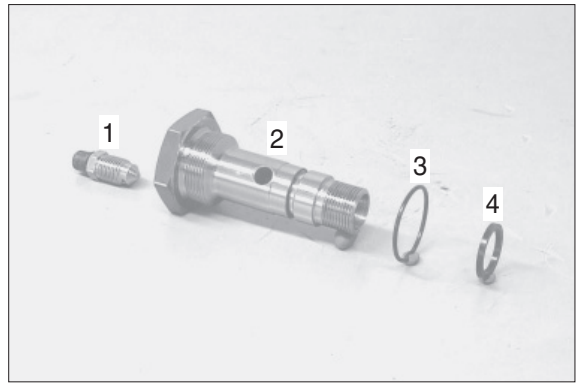

7577AAXF108

※ Step (figure 7577AAXF108 ~ 114) is to be made on both output sides.

② Install connection part.

- Tightening torque : 13.3 kgf · m
(95.9 lbf · ft)

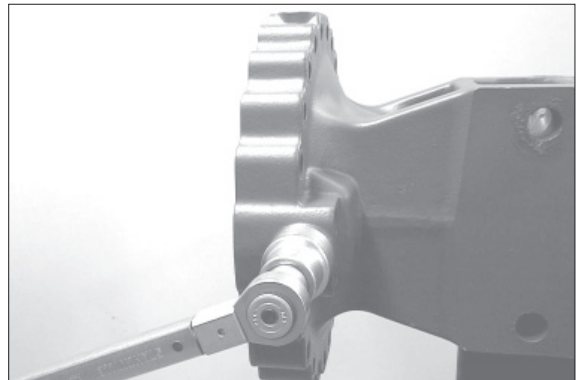

7577AAXF109

③ Provide union screw with new O-ring and install it.

- Tightening torque : 15.3 kgf · m
(111 lbf · ft)

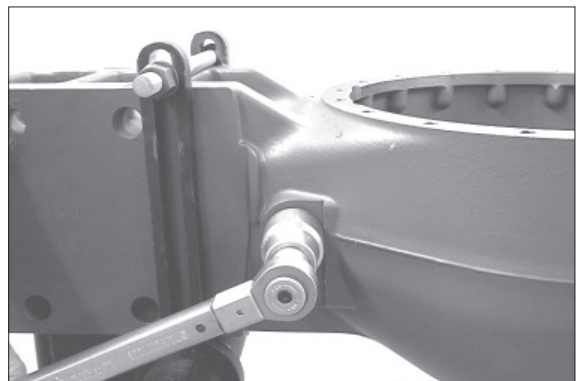

7577AAXF110

④ Insert O-ring (see arrow) into the annular groove of the brake tube.



7577AAXF111

- ⑤ Insert brake tube into the axle casing, assembling the connection part (see arrow 1) through the union screw (see arrow 2).

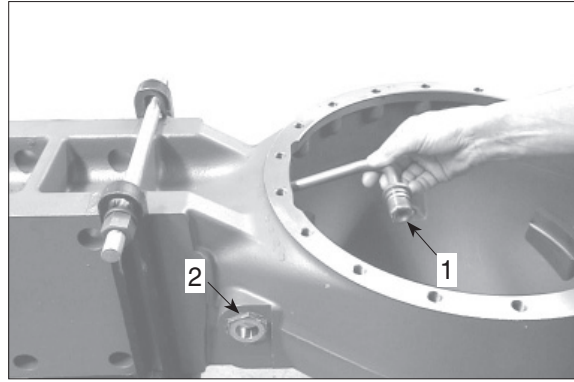

7577AAXF112

- ⑥ Fasten brake tube by means of hexagon nut and union nut (see below figure).

- Tightening torque : 10.2 kgf · m
(73.8 lbf · ft)

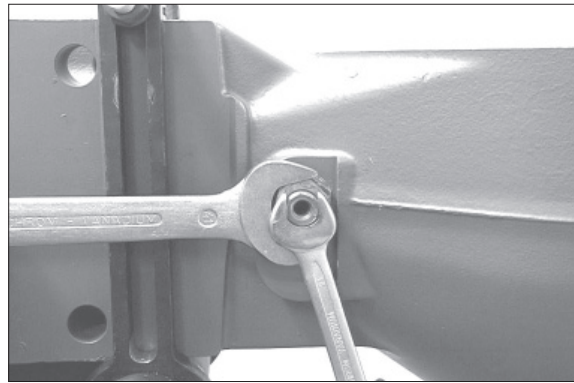

7577AAXF113

- Tightening torque : 8.2 kgf · m
(59 lbf · ft)

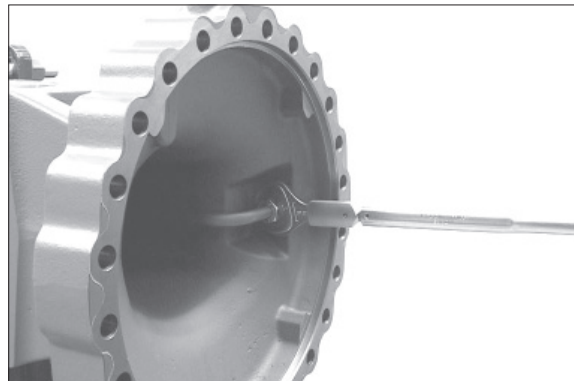

7577AAXF114

- ⑦ Install vent valve.

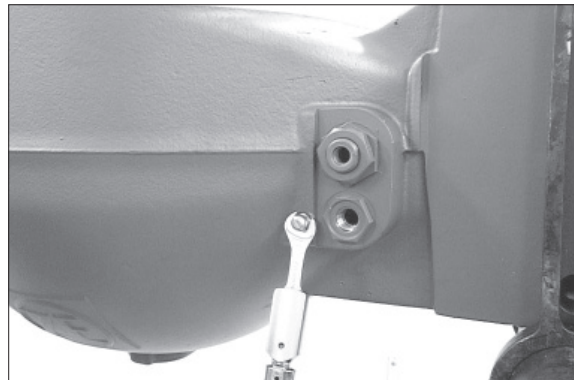

7707AAXF014

(2) Reassembly of differential carrier

- ※ If crown wheel or drive pinion are damaged, both parts have to be replaced together.

For new installation of a complete bevel gear set pay attention to the same pair number of drive pinion and crown wheel.

Determine shim thickness for a perfect tooth contact pattern

- ※ Make the following measuring steps at maximum accuracy.

Inexact measurements result in a faulty tooth contact pattern and require a repeated disassembly and reassembly of the drive pinion as well as of the differential.

- ① Install adapter pieces (1) and preliminarily fasten the bearing bracket by means of hexagon screws.

Then install stop washer (4) and measuring pin (3) and assemble measuring shaft (2) (see sketch).

- ※ Special tool

Adapter pieces	5870 500 046
Adapter pieces	5870 500 030
Measuring shaft	5870 500 001
Measuring pin	5870 351 016
Stop washer	5870 351 019

- ② Determine gap (dimension b) between measuring shaft and measuring pin by means of feeler gauge.

Dimension b e.g. 5.60 mm

EXAMPLE A :

Dimension a (= Measuring pin + stop washer) 225.00 mm
 Dimension b + 5.60 mm
 Dimension c + 15.00 mm
results in dimension X = 245.60 mm

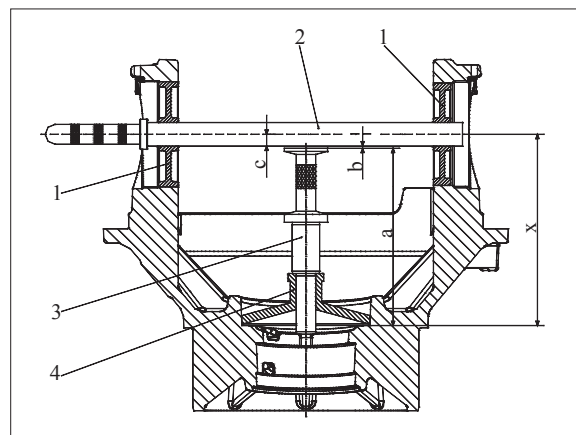

7577AAXF117

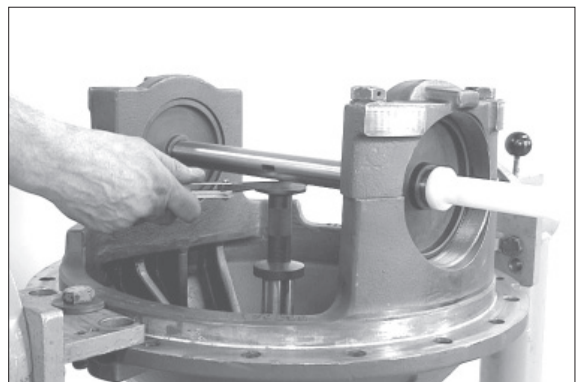

7577AAXF118

③ Determine dimension I (bearing width).

Dimension I e.g. 42.65 mm

※ Special tool

Digital depth gauge 5870 200 072

Gauge blocks 5870 200 066

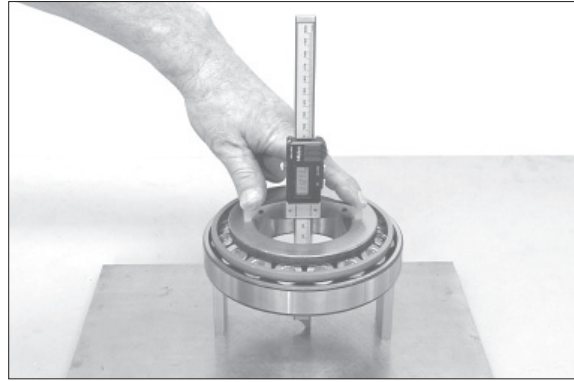

7577AAXF119

④ Read dimension II (dimension for pinion).

Dimension II e.g. 202.05 mm

EXAMPLE B :

Dimension I 42.65 mm

Dimension II + 202.05 mm

results in dimension Y = 244.70 mm

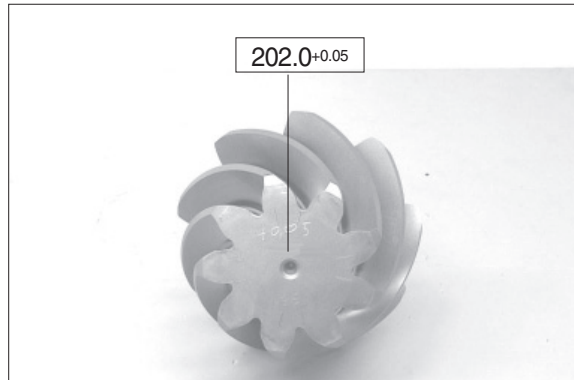

7577AAXF120

EXAMPLE C :

Dimension X 245.60 mm

Dimension Y - 244.70 mm

Difference = shim e.g. $s = 0.90$ mm

Install the drive pinion

⑤ Place determined shim e.g. $s = 0.90$ mm into the bearing bore.

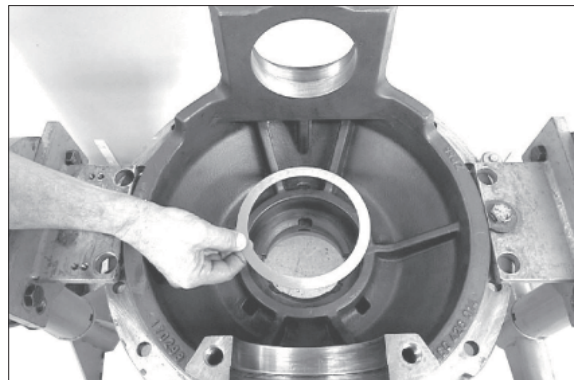

7577AAXF121

- ⑥ Undercool bearing outer ring and insert it into the bearing bore until contact.

※ Special tool

Driver 5870 050 009

Handle 5870 260 004

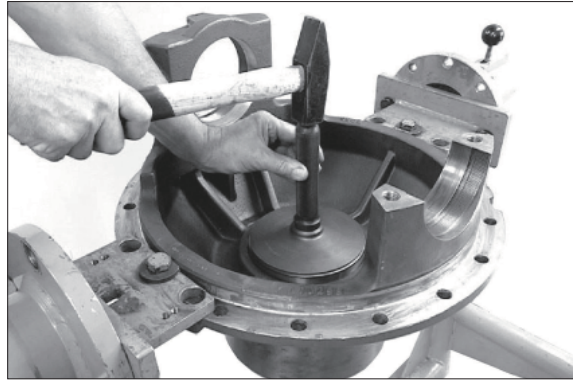

7577AAXF122

- ⑦ Undercool bearing outer ring on the input flange side and insert it until contact.

※ Special tool

Driver 5870 058 077

Handle 5870 260 002



7577AAXF123

- ⑧ Press bearing inner ring on the drive pinion until contact.

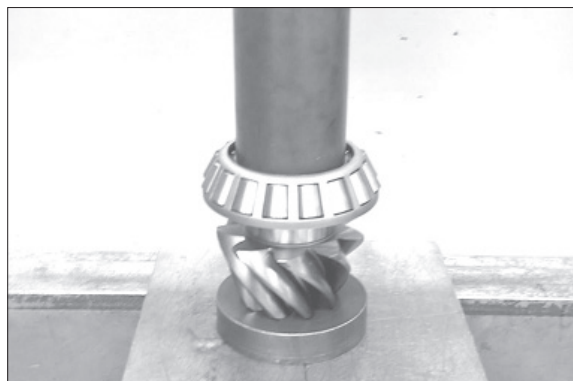

7577AAXF124

Adjust rolling moment of drive pinion bearing 0.36 ~ 0.46 kgf · m (Figure 7577AAXF125~131) :

- ⑨ Assemble spacer ring (e.g. $s = 8.10$ mm).

※ As per experience the required rolling moment is obtained by use of the spacer ring (e.g. $s = 8.10$ mm) available at disassembly.

However, a later checking of the rolling moment is imperative.

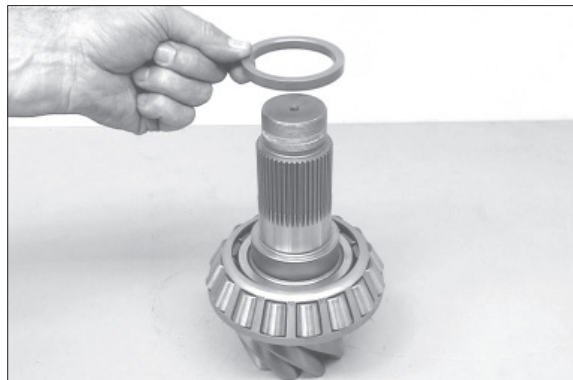

7577AAXF125

- ⑩ Insert preassembled drive pinion into the axle drive housing and assemble the heated bearing inner ring until contact.



7577AAXF126

- ⑪ Press dust protection on the input flange until contact.

※ Special tool
Driver

5870 056 003

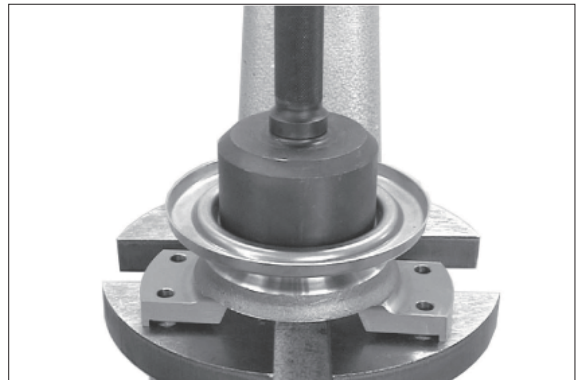

7577AAXF127

- ⑫ Assemble input flange.

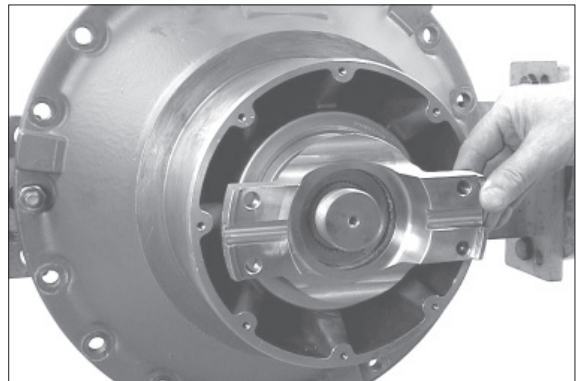

7577AAXF128

- ⑬ Assemble washer.

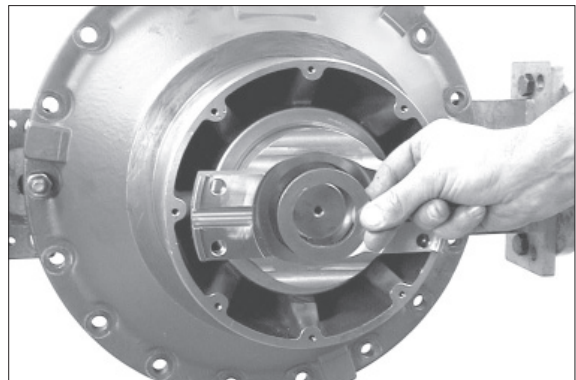

7577AAXF129

- ⑭ Unscrew slotted nut by hand and tighten it.
· Tightening torque : 122 kgf · m
(885 lbf · ft)

※ Special tool
Slotted nut wrench 5870 401 139
Fixture 5870 240 002

※ When tightening rotate drive pinion in both directions several times.

- ⑮ Check rolling moment (0.36~0.46 kgf · m).

※ For new bearings it should be tried to achieve the max. value of the rolling moment.

▲ If the required rolling moment is not obtained, correct it with an adequate spacer ring (figure 7577AAXF125), according to the following indications :
Rolling moment too low - install a thinner spacer ring
Rolling moment too high - install a thicker spacer ring.

- ⑯ Then loosen the slotted nut again and pull input flange from the drive pinion.

Install shaft seal with the sealing lip showing to the oil chamber (downwards).

※ Special tool
Driver 5870 048 233

※ The exact installation position of the shaft seal will be obtained by using the exact driver.

▲ Just before the installation wet the outer diameter of the shaft seal with spirit and fill the space between sealing and dust lip with grease.

- ⑰ Assemble input flange and finally fasten it by means of washer and slotted nut.

· Tightening torque : 122 kgf · m (885 lbf · ft)

▲ Apply Loctite (type No. 262) onto the thread of the slotted nut.

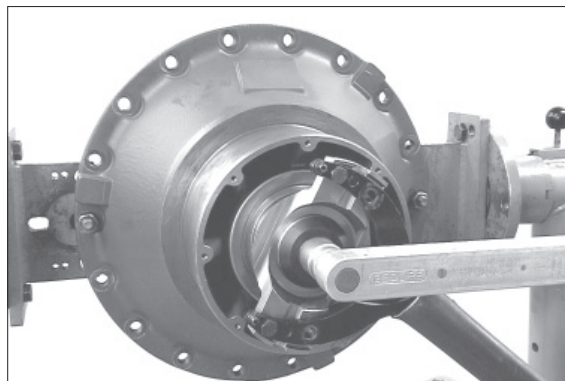

7577AAXF130

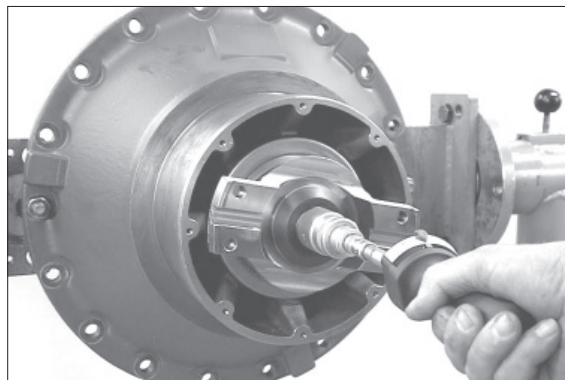

7577AAXF131



7577AAXF132

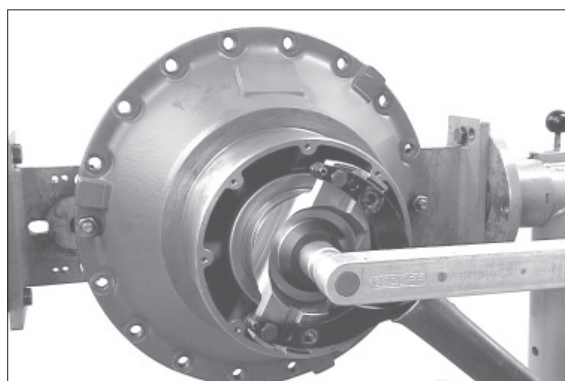

7577AAXF133

Reassembly of limited slip differential

- ⑱ Place both thrust washers into the differential housing.
- ※ Prior to installation all single parts of the differential must be oiled.

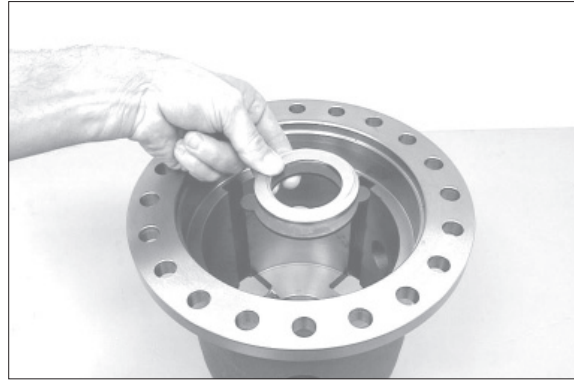

7577AAXF134

- ⑲ Starting with an outer clutch disc install alternately the outer and inner clutch discs.

▲ **Thickness of the disc pack must be identical on both sides.**

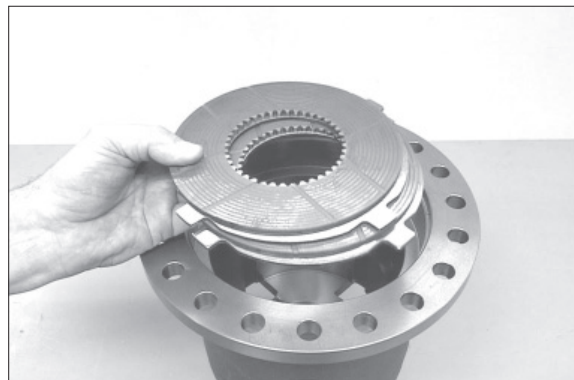

7577AAXF135

- ⑳ Put on the pressure ring.

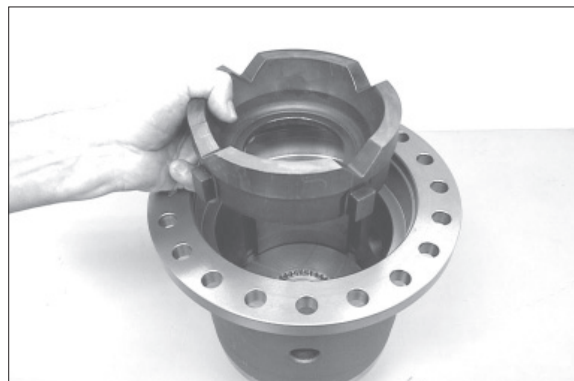

7577AAXF136

- ㉑ Insert axle bevel gear until contact and at the same time assemble all inner clutch discs with the spline.

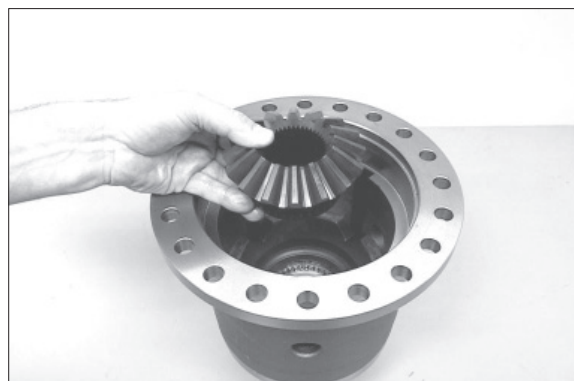

7577AAXF137

- ② Preassemble differential spider and insert it into the differential housing.

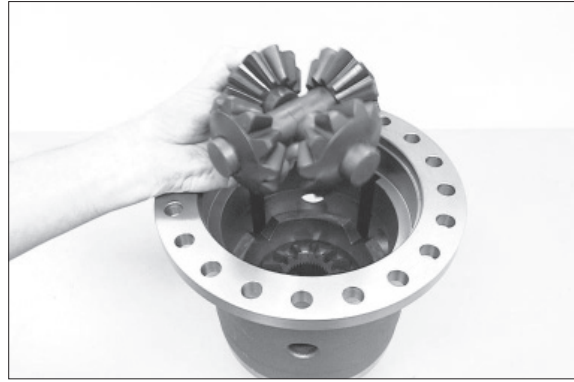

7577AAXF138

- ③ Put on the second axle bevel gear.

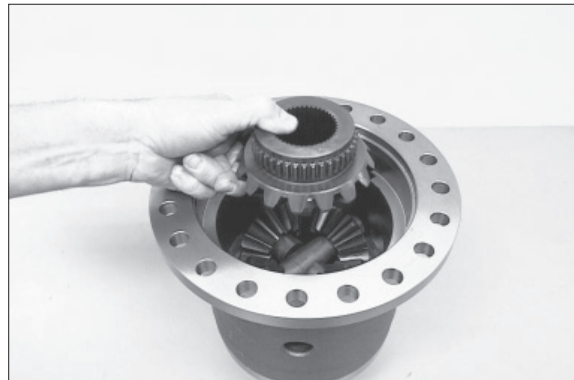

7577AAXF139

- ④ Insert the second pressure ring into the differential housing.



7577AAXF140

- ⑤ Starting with an inner clutch disc install alternately the inner and outer clutch discs.

- ▲ Thickness of the clutch disc pack must be identical on both sides.

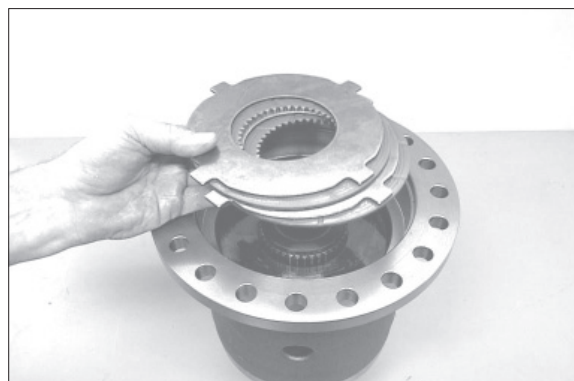

7577AAXF141

Determine disc clearance 0.2~0.8 mm

- ②⑥ Determine dimension I, from mounting face of the differential housing to plane face of the outer clutch disc.

Dimension I e.g 49.30 mm

※ Special tool

Digital depth gauge 5870 200 072

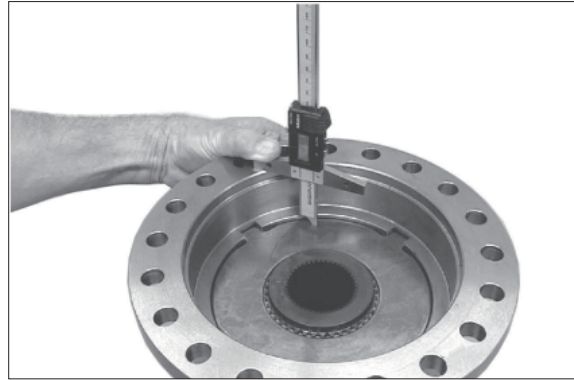

- ②⑦ Determine dimension II, from contact surface of the outer clutch disc to the mounting face of the housing cover.

Dimension II e.g 48.95 mm

EXAMPLE D :

Dimension I 49.30 mm

Dimension II - 48.95 mm

Difference = Disc clearance = 0.35 mm.

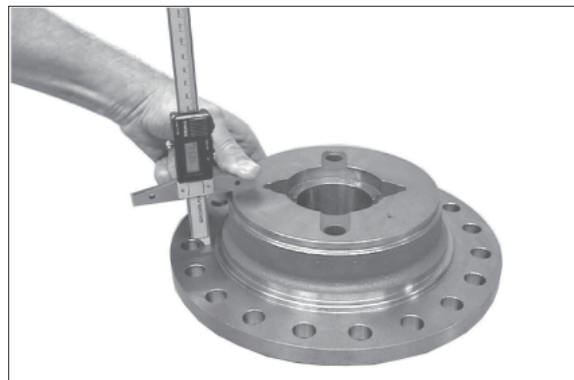

7577AAXF143

※ If the required disc clearance is not obtained, correct it with the adequate outer clutch discs (s = 2.7, s = 2.9, s = 3.0, s = 3.1 or s = 3.3 mm), taking care that the difference in thickness between the left and the right disc pack must only be 0.01 at a maximum.

- ②⑧ Fix both thrust washers with grease into the recess of the housing cover.

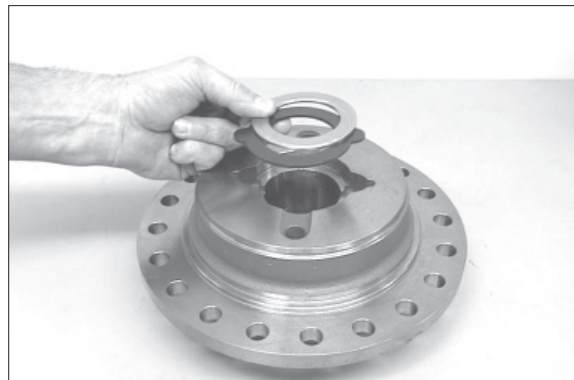

7577AAXF144

- ②⑨ Put on the housing cover and fasten it by means of cap screws (2EA).
- Tightening torque (M10/8.8) :
4.7 kgf · m (33.9 lbf · ft)



7707AAXF015

- ③⑩ Heat crown wheel and install it until contact.
- ※ Special tool
Adjusting screws 5870 204 040

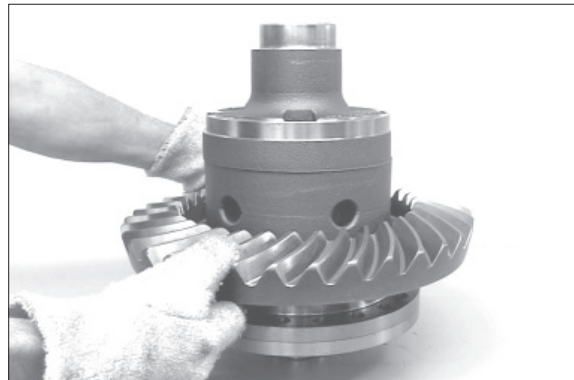

7577AAXF145

- ③⑪ Fix differential by means of press and fasten crown wheel by means of new locking screws.
- Tightening torque : 39.8 kgf · m
(288 lbf · ft)

▲ Only use of new locking screws is permissible.

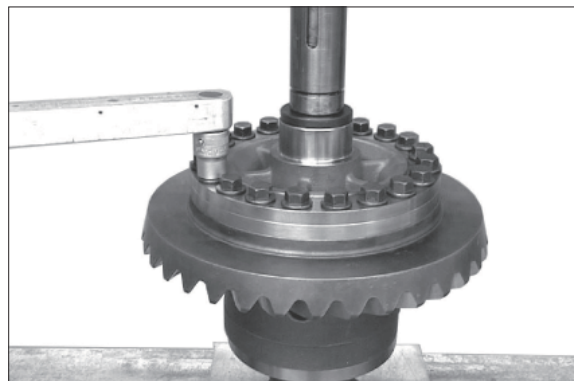

7577AAXF146

- ③⑫ Press on both bearing outer rings until contact.



7577AAXF147

- ③③ Insert differential into the axle drive housing by means of lifting tackle.

※ Special tool

Lifting tackle

5870 281 013

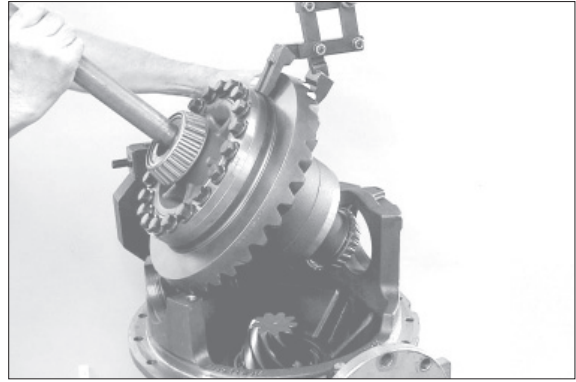

7577AAXF148

- ③④ Place bearing outer ring into the axle drive housing.

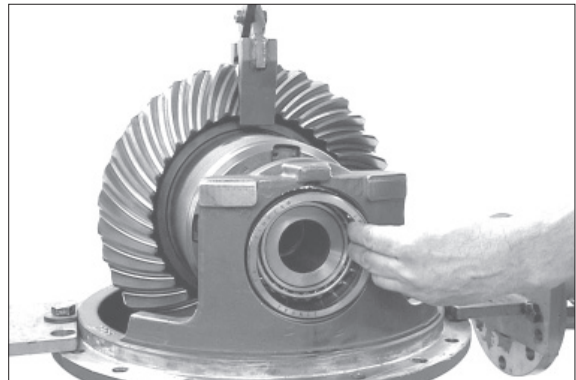

7577AAXF149

- ③⑤ Preliminarily fix the bearing outer ring by means of adjusting nut.

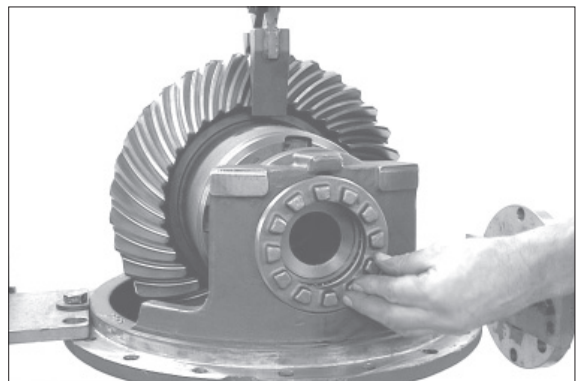

7577AAXF150

- ③⑥ Install crown wheel-sided bearing outer ring.

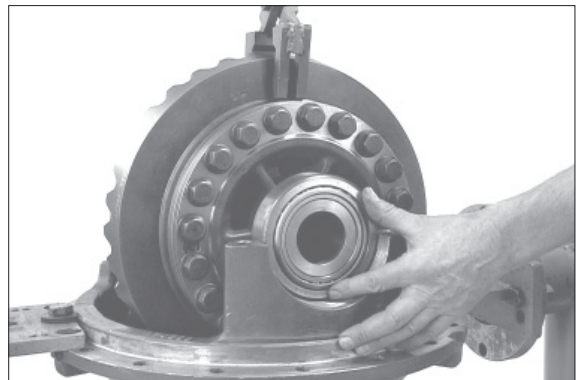

7577AAXF151

- ③7 Preliminarily fix the crown wheel-sided bearing outer ring by means of the second adjusting nut.

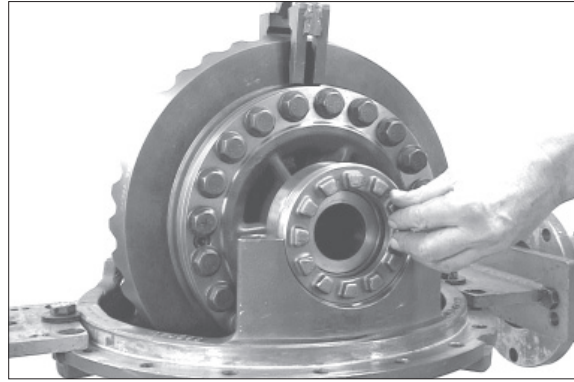

7577AAXF152

- ③8 Put on bearing bracket and fasten it by means of hexagon screws and washers.
 - Tightening torque (M18/10.9) :
39.8 kgf · m (288 lbf · ft)

※ Pay attention to clearance of the adjusting nut.

▲ Apply Loctite (type No. 262) onto threads of the hexagon screws.

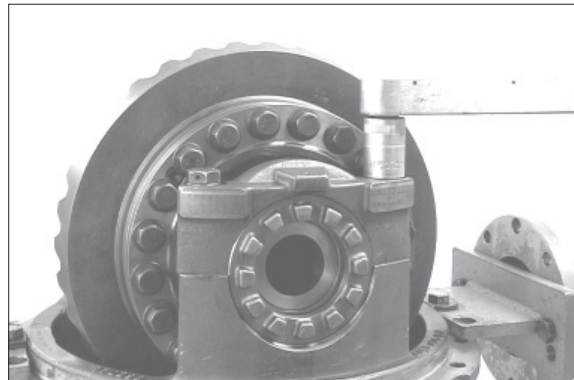

7577AAXF153

Adjustment of backlash and bearing preload

- ③9 Place dial indicator right-angled at the outer diameter of the tooth flank (crown wheel).
Then install both adjusting nuts only to such an extent that the required backlash - see the value etched on the outer diameter of the crown wheel - is reached.

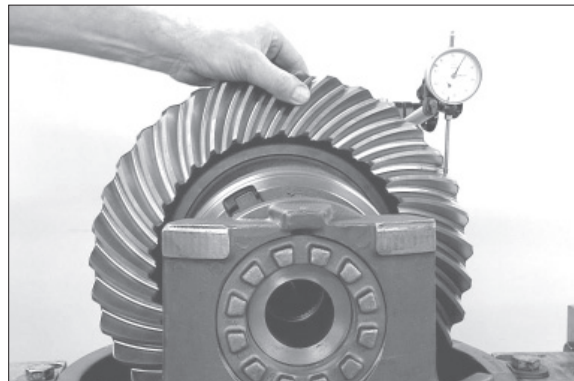

7577AAXF154

- ※ Special tool
Magnetic stand 5870 200 055
Dial indicator 5870 200 057

※ At this step rotate the differential several times.

- ④0 Determine bracket width and correct it on both adjusting nuts, if required.

Bracket width448 - 0.05 mm

- ※ Special tool
Caliper gauge 5870 200 058

Then check backlash once again.

※ Adjusting of the bracket width results in the required bearing preload.

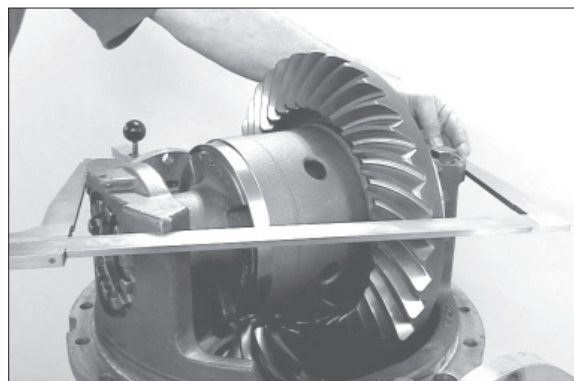

7577AAXF155

- ④① Cover some tooth flanks of the crown wheel with marking ink and roll crown wheel in both directions over the drive pinion.

Compare the obtained tooth contact pattern with the examples on page 3-267

- ▲ If the tooth contact pattern differs, there has been a measuring error at determination of the shim (figure 7577AAXF121/page 3-211), what is imperative to be corrected.

- ④② Secure both adjusting nuts by means of slotted pins.

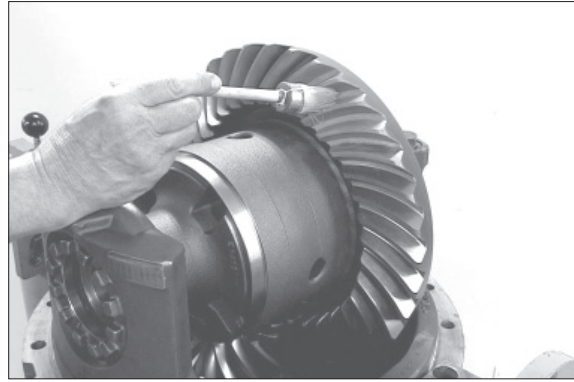

7577AAXF156

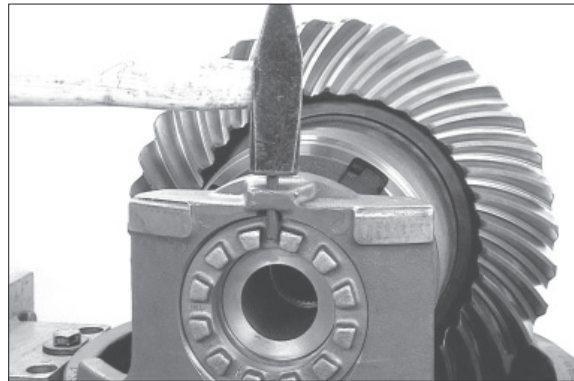

7577AAXF157

- ④③ Install two adjusting screws and insert differential carrier into the axle casing until contact by means of lifting tackle.

※ Special tool

Adjusting screws 5870 204 023

Lifting tackle 5870 281 044

※ Observe radial location (see marking Page 3-199 / Figure 7577AAXF081).

- ▲ Apply sealing compound (three Bond Type 1215) on mounting face.

- ④④ Fasten differential carrier by means of new locking screws.

· Tightening torque : 25.5 kgf · m
(184 lbf · ft)

- ▲ Only use of the new locking screws is permissible.

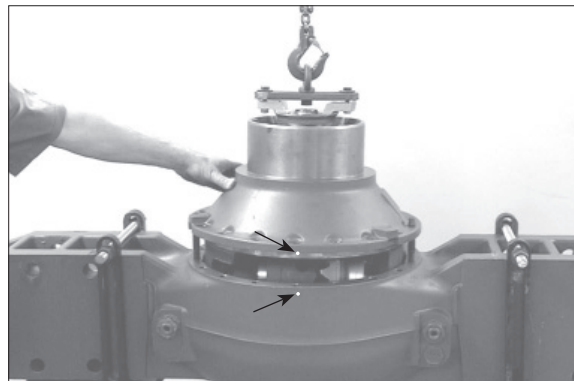

7577AAXF158

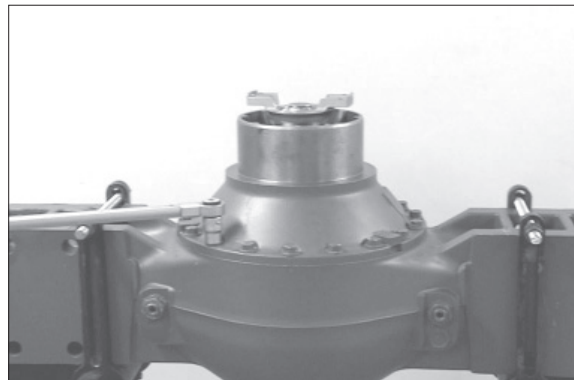

7577AAXF159

- ④⑤ Insert stub shaft into spline of the axle bevel gear until contact.

Then fix O-ring (see arrow) by means of grease into the recess of the axle casing.

- ※ Step (Figure 7577AAXF160 ~ 163) is to be made on both output sides.

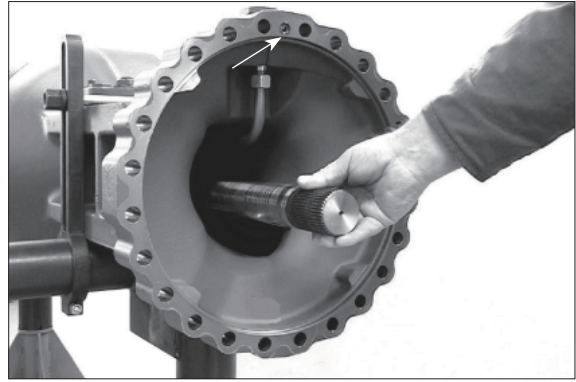

7577AAXF160

- ④⑥ Thrust washer (s) removed at disassembly have to be fixed in the sun gear shaft by means of grease.



7577AAXF161

- ④⑦ Place complete output by means of lifting tackle to the axle casing until contact.

- ※ Special tool
Lifting bracket 5870 281 043

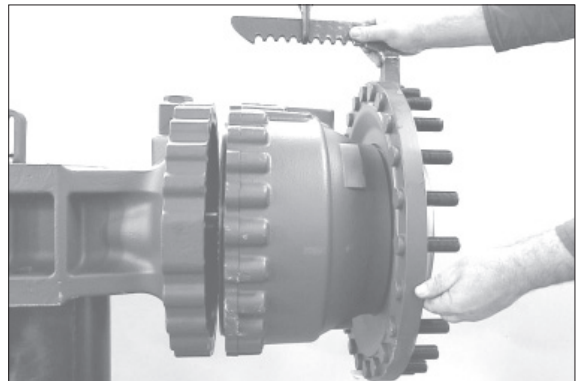

7577AAXF162

- ④⑧ Fasten output by means of hexagon screws and washers.

- Tightening torque (M18/10.9) :
39.8 kgf · m (288 lbf · ft)

- ※ Prior to putting into operation of the axle, fill oil in accordance with lubrication instructions.

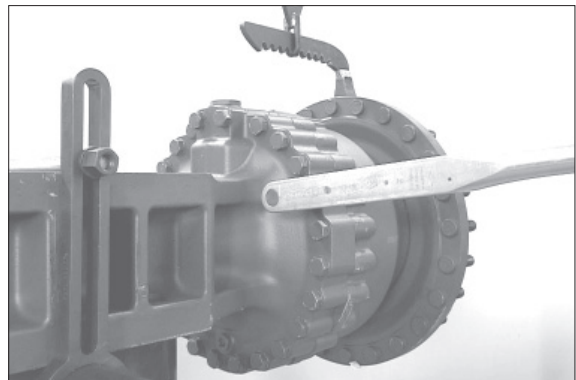

7577AAXF163

※ **BACKLASH CHECK**

- Applied the paint (or red lead) on the surface of several bevel gear teeth.
- Turn the pinion gear and check the contact pattern.

Correct pattern

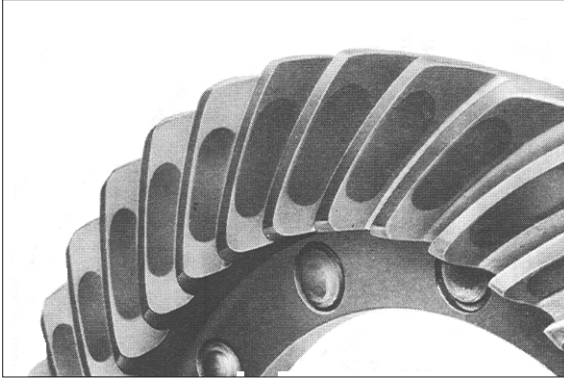

WTHAX16

Concave side

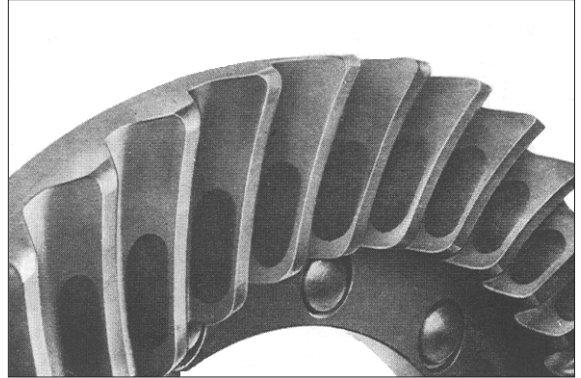

WTHAX17

Convex side

※ **ADJUSTMENT**

Incorrect pattern : high contact

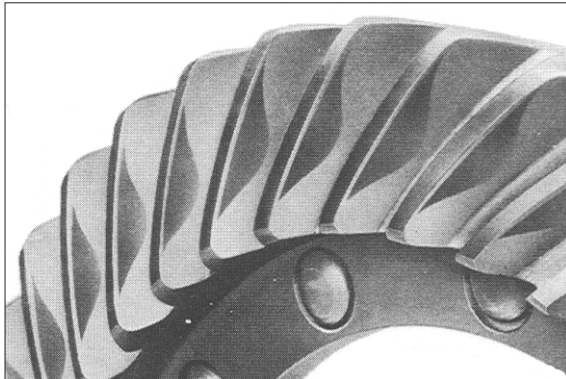

WTHAX18

Concave side

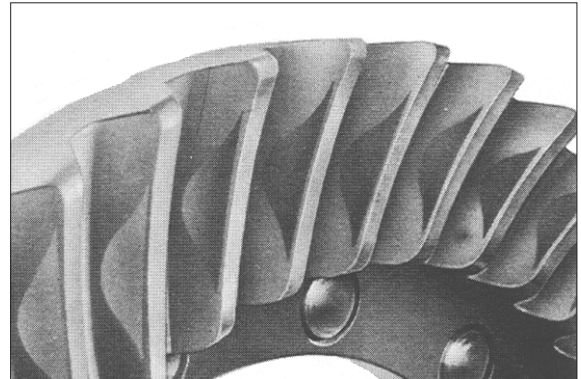

WTHAX19

Convex side

- Reduce the distance (-)

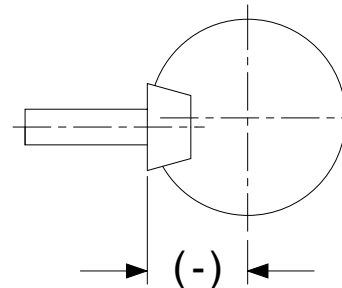

WTHAX20

Incorrect pattern, low contact

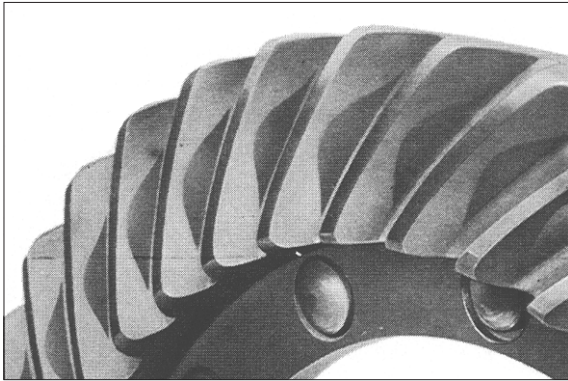

WTHAX21

Concave side

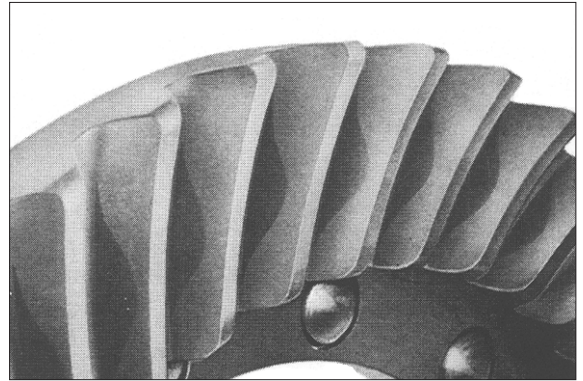

WTHAX22

Convex side

- Add the distance (+)

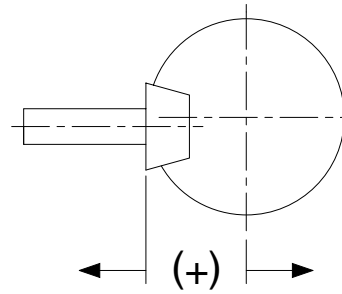

WTHAX23

• REAR AXLE

1) DISASSEMBLY OF OUTPUT AND BRAKE

(1) Fasten axle on assembly truck.

※ Special tool

Assembly truck 5870 350 000

Holding fixtures 5870 350 077

Clamps 5870 350 075

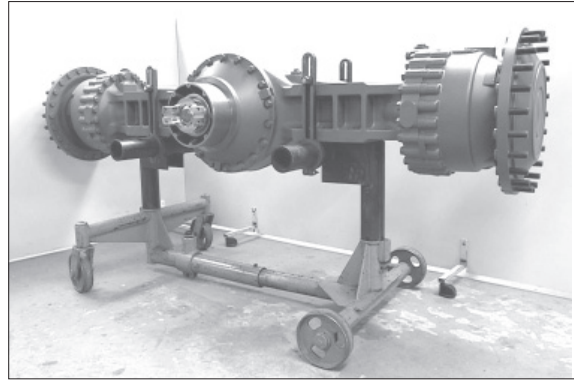

7577AAXF001

(2) Loosen screw plugs (3EA, see Figure 7577AAXF002 and 003) and drain oil from axle casing.

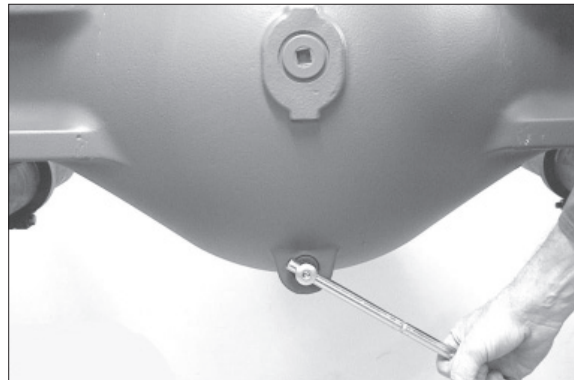

7577AAXF002

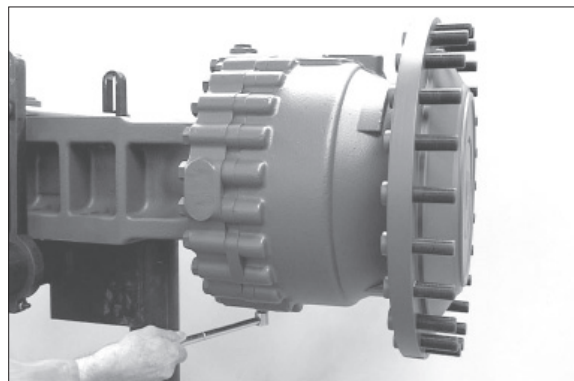

7577AAXF003

(3) Press off cover from the output shaft.

※ Special tool

Pry bar set 5870 345 065

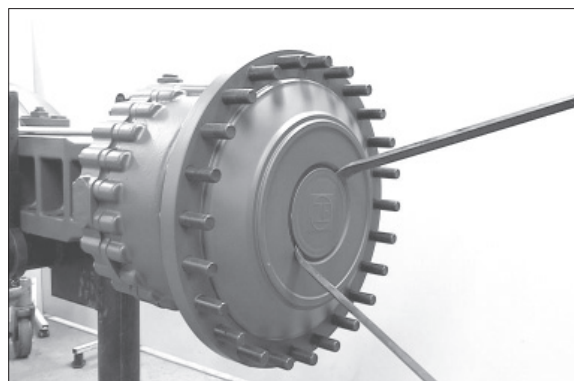

7577AAXF004

(4) Pull slotted pin by means of the striker out of the bore in the slotted nut.

※ Special tool

Striker 5870 650 001

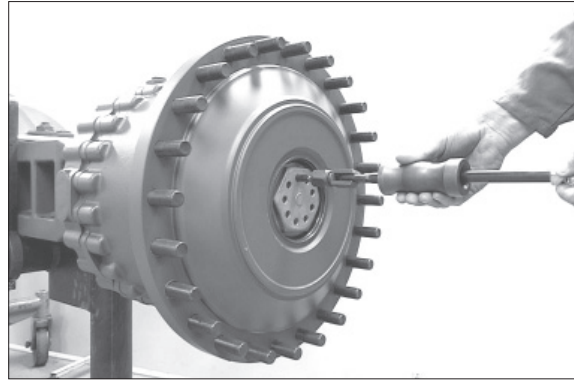

7577AAXF005

(5) Loosen slotted nut.

※ Special tool

Socket spanner 5870 656 078

Centering bracket 5870 912 028

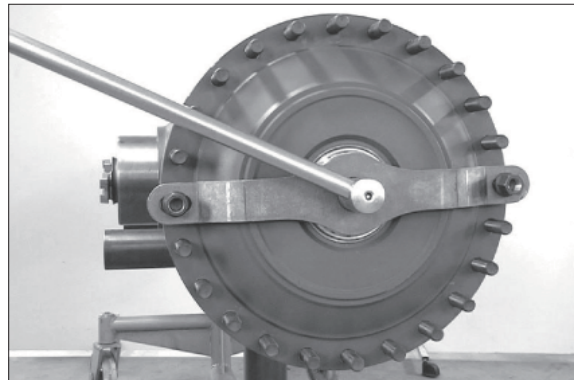

7577AAXF006

(6) Secure output by means of lifting tackle and loosen hexagon screws.

※ Special tool

Lifting bracket 5870 281 043

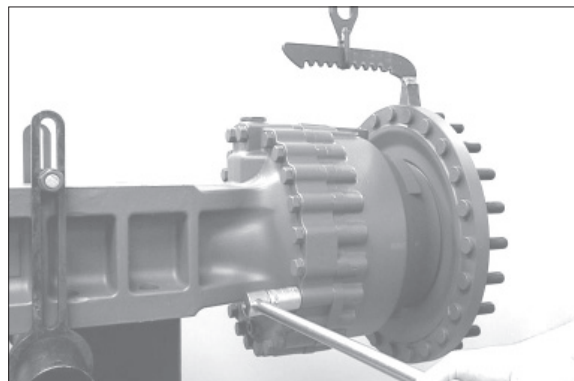

7577AAXF007

(7) Separate complete output from the axle casing.

※ Pay attention to released O-ring (see arrow).

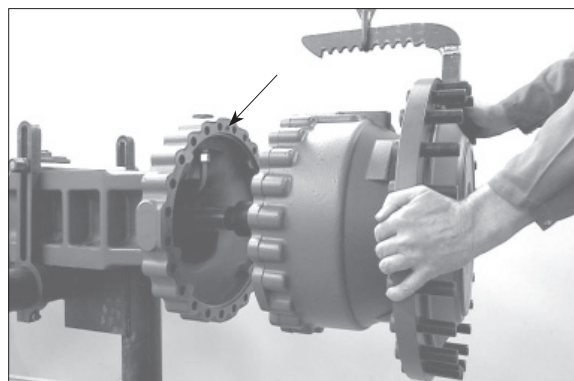

7577AAXF008

- (8) Pull stub shaft out of the sun gear shaft.
※ Pay attention to possibly released shim (s).

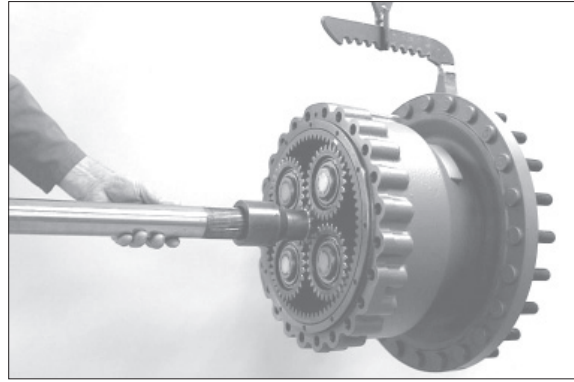

7577AAXF009

- (9) Remove shim (s) from the sun gear shaft.

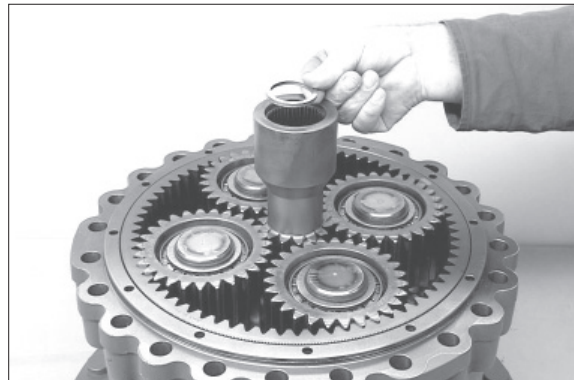

7577AAXF010

- (10) Pull sun gear shaft out of the planet gears.

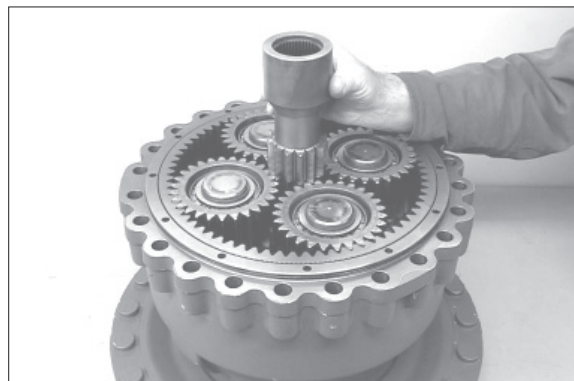

7577AAXF011

- (11) Lift planet carrier out of the brake housing.

- ※ Special tool
Internal extractor 5870 300 019

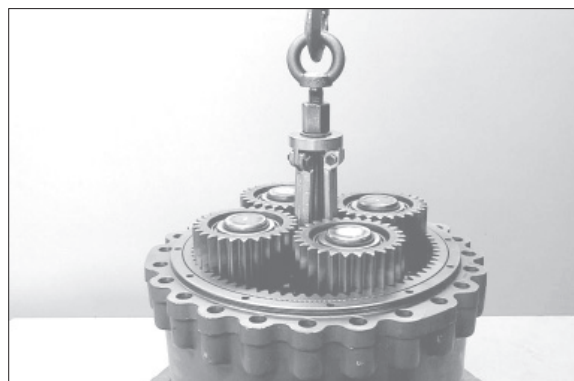

7577AAXF012

(12) Squeeze out the retaining ring.

- ※ Special tool
Set of external pliers 5870 900 015

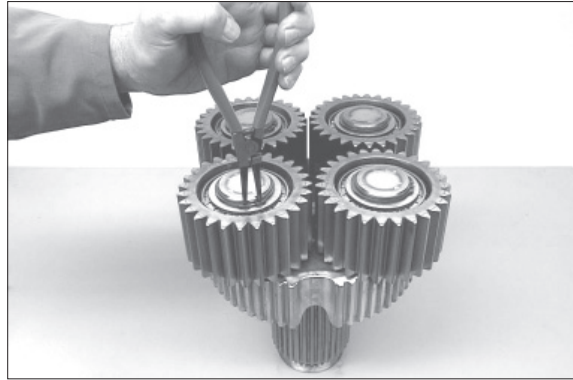

7577AAXF013

(13) Pull off the planet gear and remove the released bearing inner ring.

- ※ Special tool
Three-armed puller 5873 971 002



7577AAXF014

(14) Pull off the bearing inner ring.

- ※ Special tool
Gripping insert 5873 001 020
Basic set 5873 001 000

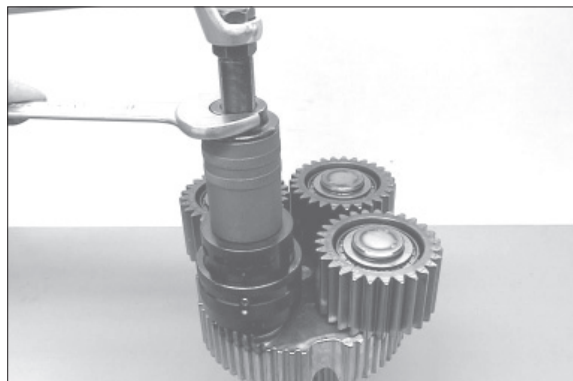

7577AAXF015

(15) Separate ring gear from the brake housing by means of two-armed puller.

- ※ Special tool
Two-armed puller 5870 970 007

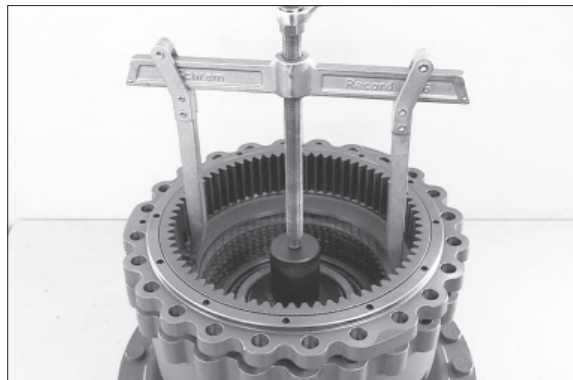

7577AAXF016

(16) Remove O-rings (see arrows) from the annular grooves of the ring gear.

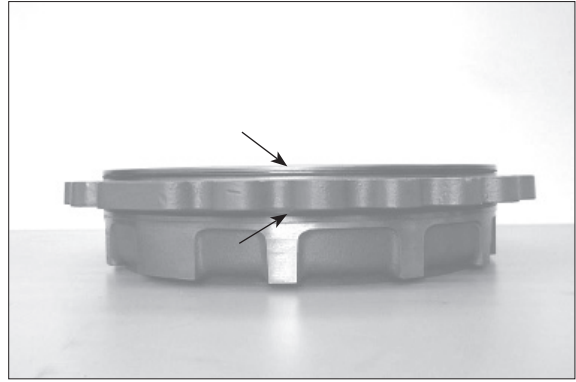

7577AAXF017

(17) Remove O-ring (see arrow) from the recess of the brake housing.

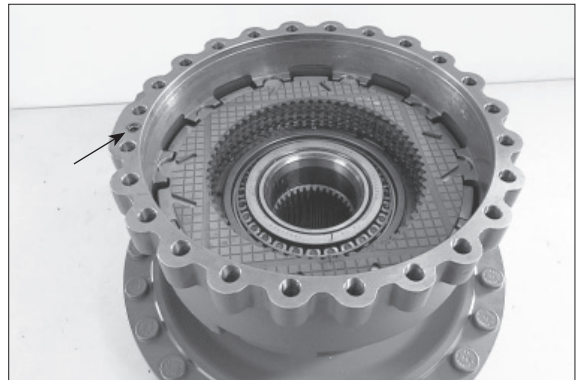

7577AAXF018

(18) Take the disc pack out of the brake housing.

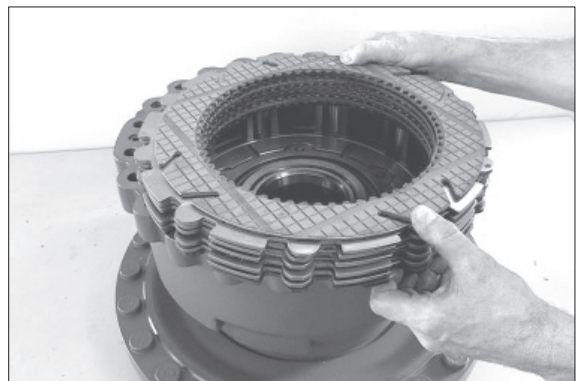

7577AAXF019

(19) Install slotted pins (6EA) in the support shim until they are flush-mounted.

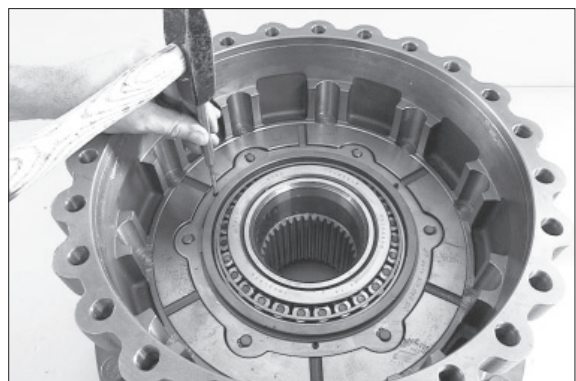

7577AAXF020

(20) Squeeze out the circlip.

※ Special tool

Set of external pliers

5870 900 016

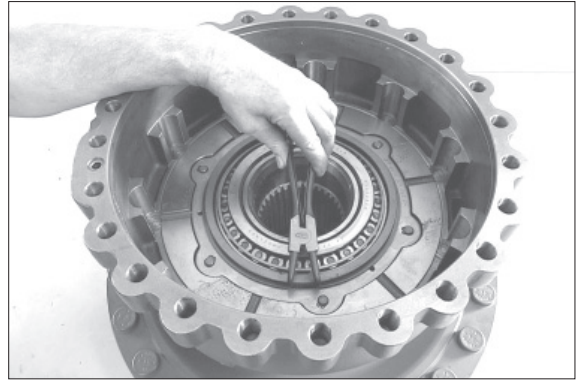

7577AAXF021

(21) Press piston out of the brake housing by means of compressed air.



7577AAXF022

(22) Press support shim out of the piston by means of the automatic piston adjusting.

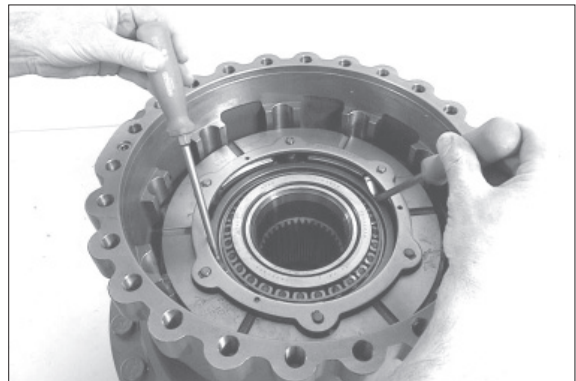

7577AAXF023

(23) Drive slotted pins (6EA) out of the support shim.

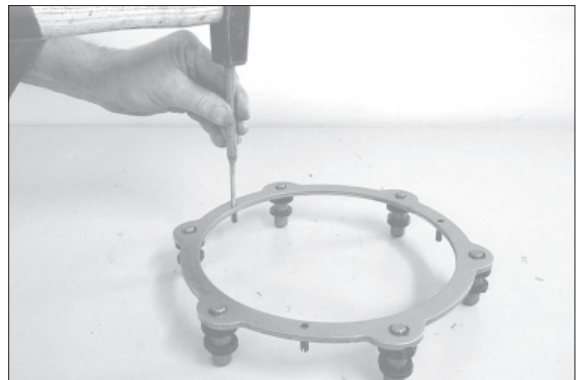

7577AAXF024

(24) Preload cup springs by means of a press and squeeze out the circlip.

※ Special tool

Assembly pliers 5870 900 051

Assembly fixture 5870 345 096

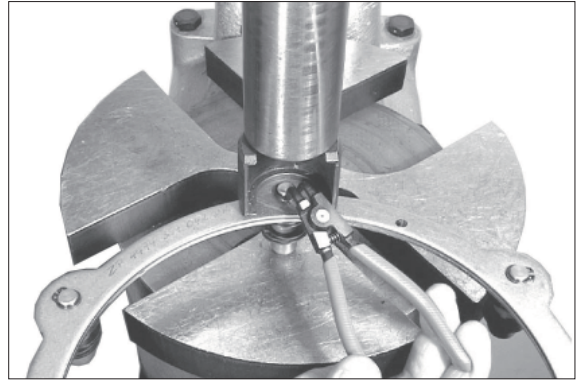

7577AAXF025

(25) Pull pin out of the support shim and remove released cup springs.



7577AAXF026

(26) Press gripping rings from the pin.

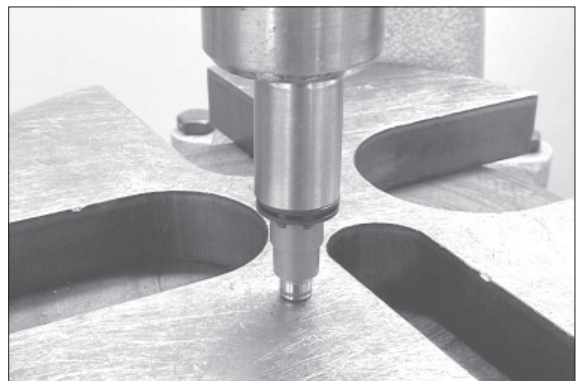

7577AAXF027

(27) Lift piston out of the brake housing.

※ Special tool

Adjusting device 5870 400 001



7577AAXF028

(28) Remove guide ring, support rings and U-rings from the annular grooves of the brake housing.

※ See below sketch for installation position of the single parts.

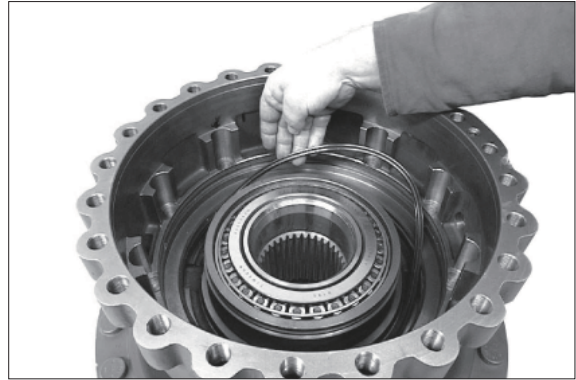

7577AAXF029

To the sketch :

- 1 Brake housing
- 2 Guide ring
- 3 Support ring
- 4 U-ring
- 5 U-ring
- 6 Support ring
- 7 Output shaft

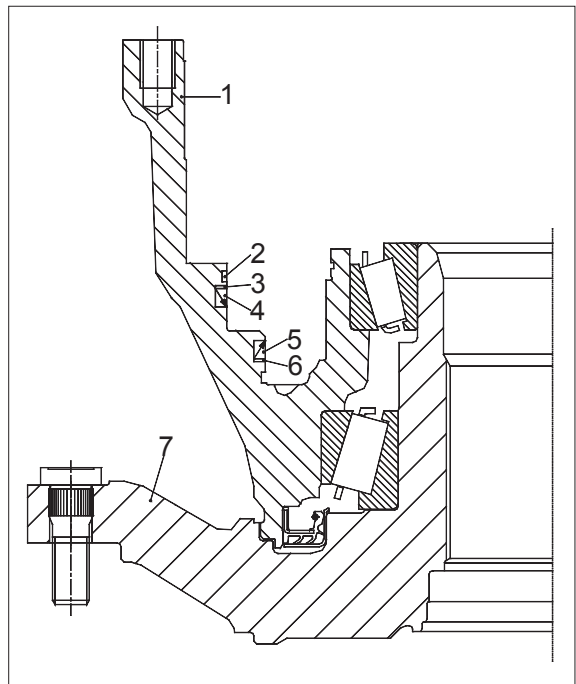

7577AAXF030

(29) Pull brake housing by means of two-armed puller from the output shaft and remove the released bearing inner ring.

※ Special tool

- | | |
|------------------|--------------|
| Two-armed puller | 5870 970 007 |
| Clamping bracket | 5870 654 034 |
| Press bush | 5870 506 140 |

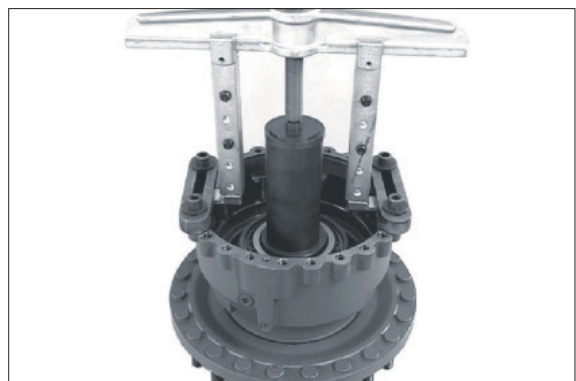

7577AAXF031

(30) Lift brake housing with lifting tackle from the output shaft.

- ※ Special tool
- Lifting chain 5870 281 047
- Eye bolts 5870 204 071

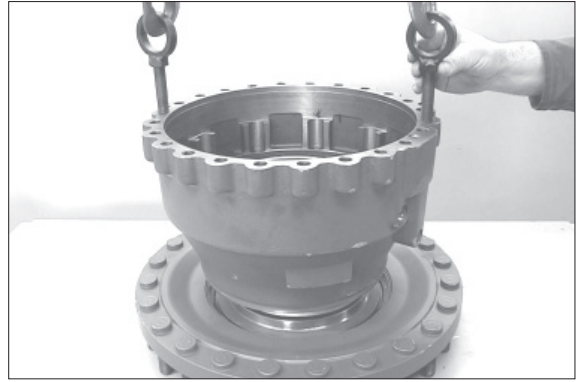

7577AAXF032

(31) If necessary drive both bearing outer rings out of the bearing bores in the brake housing.



7577AAXF033

(32) Press shaft seal out of the brake housing.

- ※ Special tool
- Pry bar set 5870 345 065



7577AAXF034

(33) Pull bearing inner ring from the output shaft.

- ※ Special tool
- Rapid grip 5873 014 013
- Basic set 5873 004 001

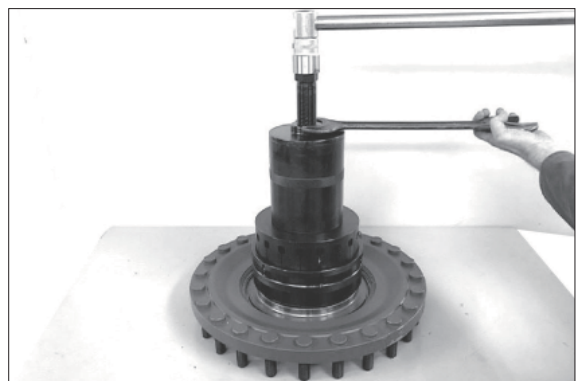

7577AAXF035

(34) Press off bearing sheet from the output shaft.

※ Special tool
Pry bar set

5870 345 065

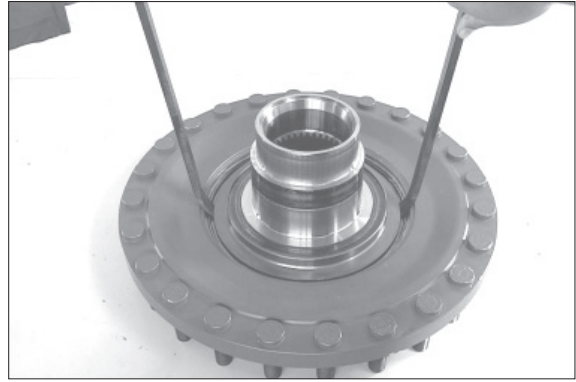

7577AAXF036

2) REASSEMBLY OF OUTPUT AND BRAKE

(1) Insert wheel bolt into the output shaft until contact.

※ Special tool

Wheel bolt puller-basic set 5870 610 010

Insert (7/8"-14 UNF) 5870 610 011

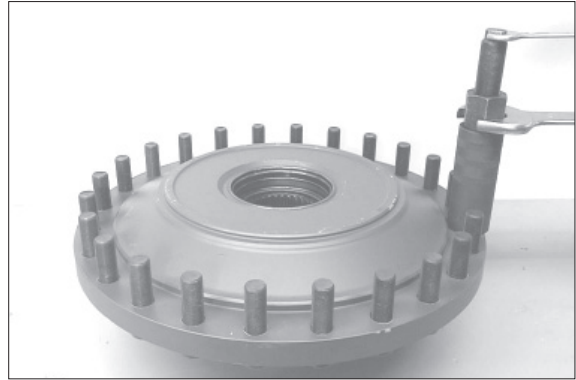

7577AAXF037

(2) Assemble bearing sheet (shaft seal).

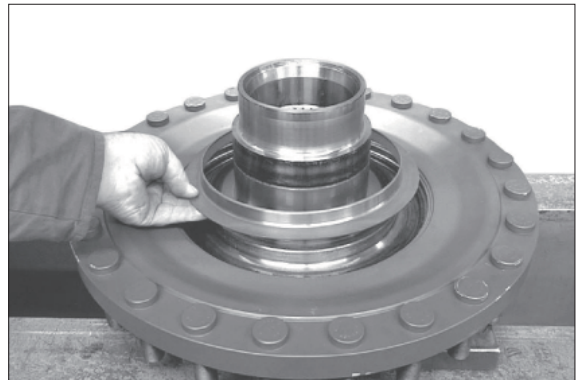

7577AAXF038

(3) Press bearing sheet over the collar of the output shaft.

※ Special tool

Pressure ring 5870 506 141

※ The exact installation position of the bearing sheet will be obtained by using the specified pressure ring.

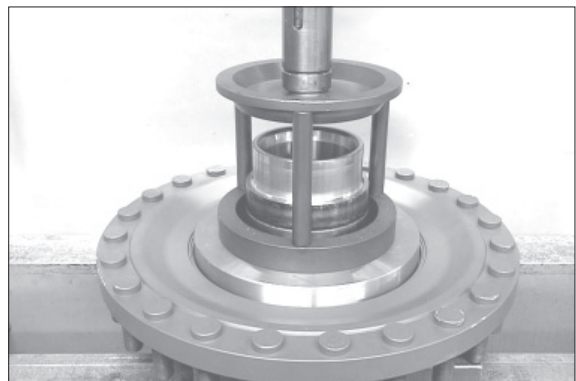

7577AAXF039

(4) Heat the roller bearing and install it until contact.

※ After cooling-down the bearing has to be installed subsequently.



7577AAXF040

- (5) Press both bearing outer rings into the brake housing until contact.

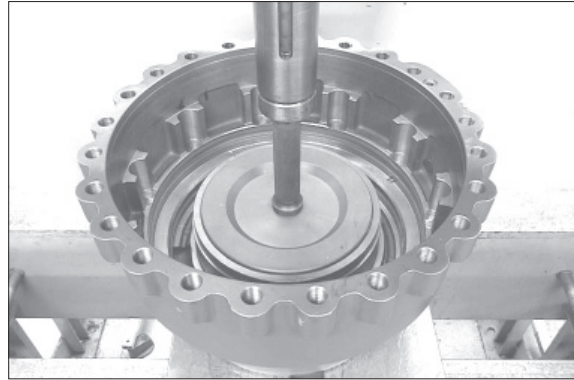

7577AAXF041

- (6) Install shaft seal with the sealing lip showing to the oil chamber (see below sketch).

- ※ Special tool
Driver 5870 051 052
- ※ The exact installation position of the shaft seal will be obtained by using the specified driver.

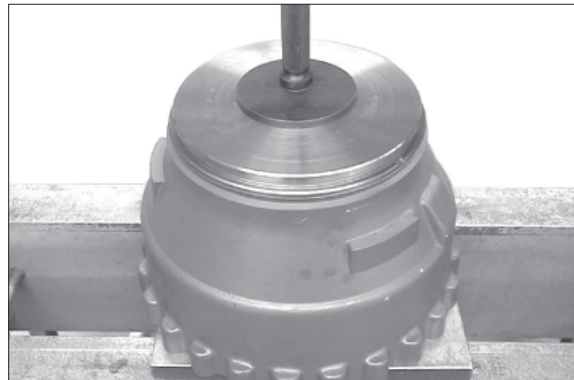

7577AAXF042

- ▲ **Just before the installation wet the outer diameter of the shaft seal with spirit.**

To the sketch :

- 1 Brake housing
- 2 Shaft seal
- * Grease filling

- ※ Fill the space between sealing and dust lips with grease.

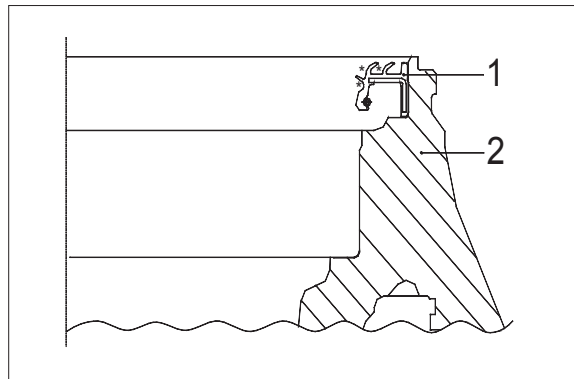

7577AAXF043

- (7) Install the preassembled brake housing by means of the lifting tackle over the output shaft until contact.

- ※ Special tool
Lifting chain 5870 281 047
Eye bolts 5870 204 071



7577AAXF044

(8) Heat the roller bearing and install it until contact.

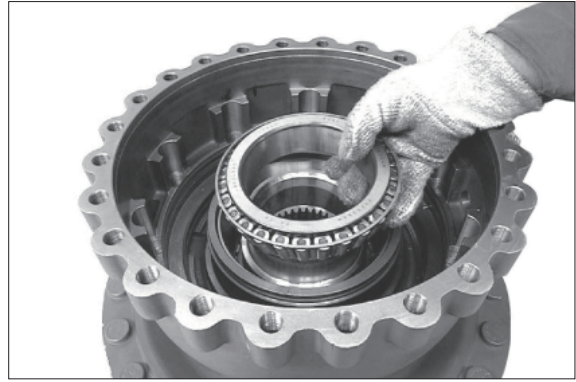

7577AAXF045

(9) Insert support and U-rings into the annular grooves of the brake housing.

※ Pay attention to the installation position, see below sketch.

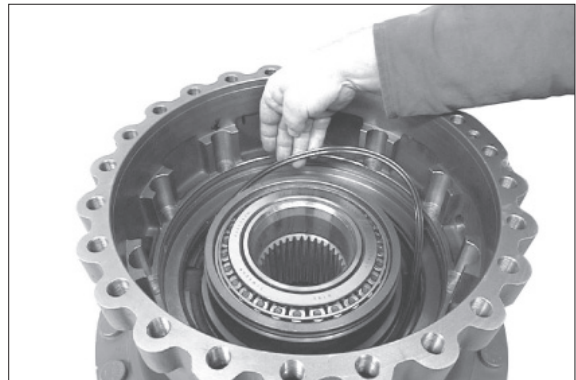

7577AAXF046

To the sketch :

- 1 Brake housing
- 2 Guide ring
- 3 Support ring
- 4 U-ring
- 5 U-ring
- 6 Support ring
- 7 Output shaft

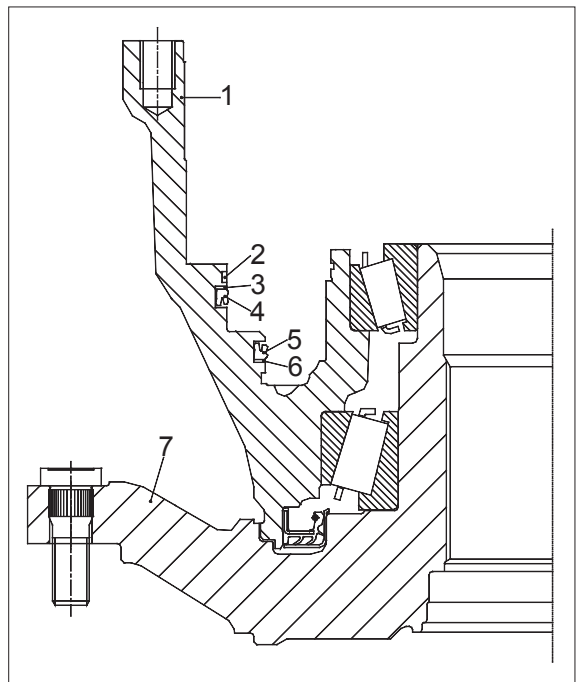

7577AAXF047

(10) Clean annular groove of the brake housing with spirit.

Then insert the guide ring into the annular groove (also see sketch page 3-237) and fix it with Loctite (type No. 415) at its extremities.

※ Guide ring must have contact on the whole circumference.

▲ Upon installation the orifice of the guide ring must show upwards (12 o'clock).

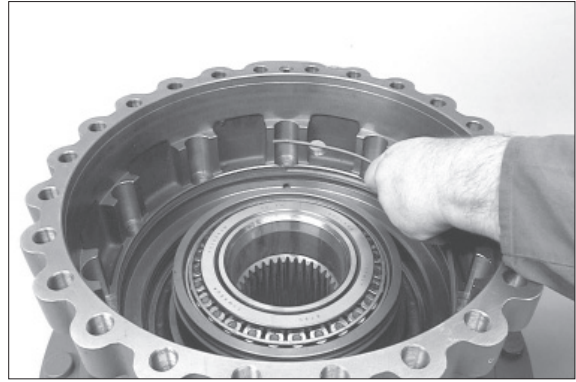

7577AAXF048

(11) Insert piston into the brake housing and install it cautiously until contact.

※ Apply sufficiently oil on the sliding surface of the piston or support rings, U-rings and guide ring (use W-10 oils).

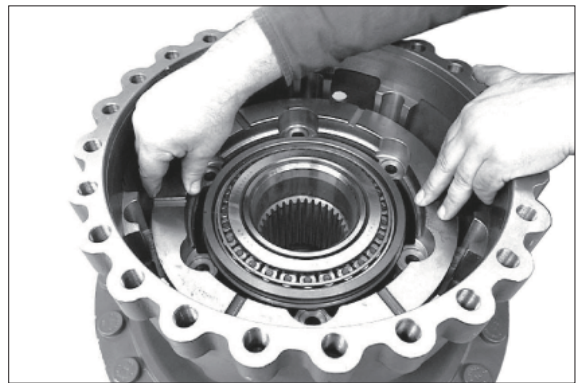

7577AAXF049

(12) Insert pins into the assembly fixture until contact.

※ Special tool

Assembly fixture 5870 345 096

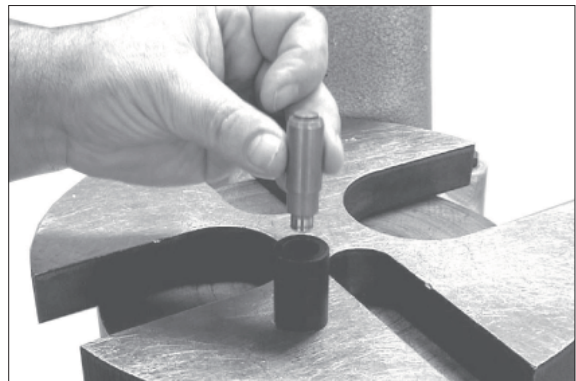

7577AAXF050

(13) Press gripping rings (4EA, see arrows) onto the pins until contact on the assembly fixture.

※ The exact installation dimension (see sketch page 3-239) of the gripping rings is obtained when using the specified assembly fixture.

▲ Observe the installation position, install gripping rings with the orifices offset by 180° to each other.

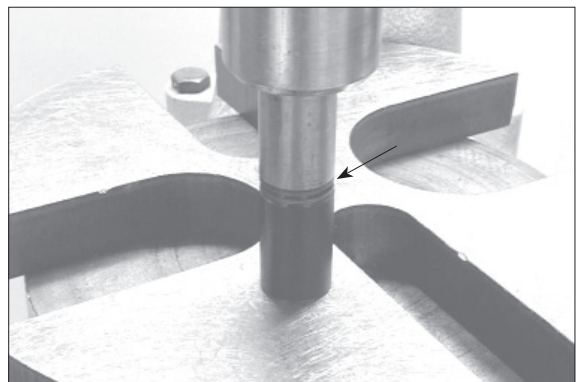

7577AAXF051

(14) Install cup springs (7 pieces each/pin).

- ※ Pay attention to the installation position of the cup springs, see below sketch.



7577AAXF052

To the sketch :

- 1 Pin
- 2 Gripping rings
- 3 Cup springs
- 4 Support shim
- 5 Circlip
- X Installation dimension gripping rings
 10.5 ± 0.3 mm

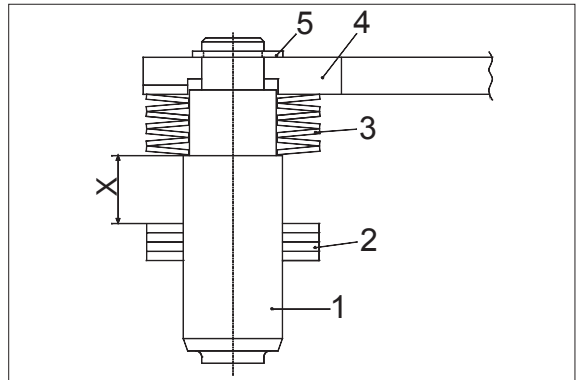

7577AAXF053

(15) Insert preassembled pins into the support shim and fix it by means of the circlip.

- ※ Special tool
Assembly pliers 5870 900 051
- ※ Pay attention to clearance of the cup springs.

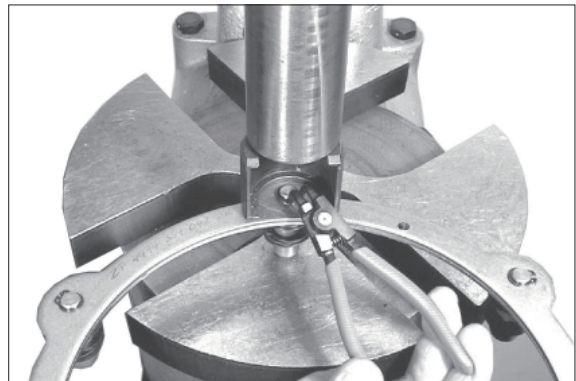

7577AAXF054

(16) Insert preassembled support shim into the piston.

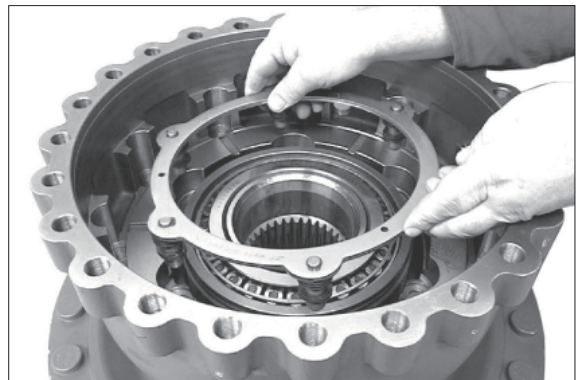

7577AAXF055

(17) Fix support shim by means of the circlip.

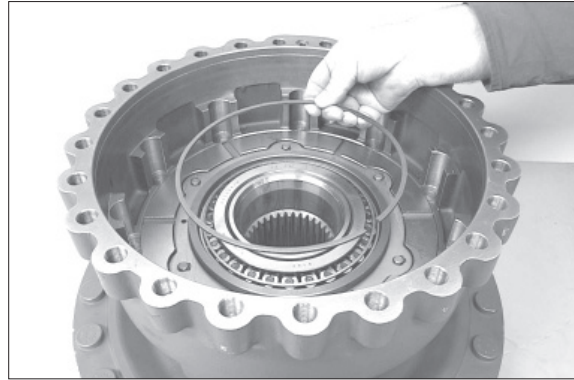

7577AAXF056

(18) Drive slotted pins (6EA) into the bores of the support shim to lock the circlip.

- ※ Special tool
Drive mandrel 5870 705 011
- ※ Pay attention to the installation position, see below sketch.

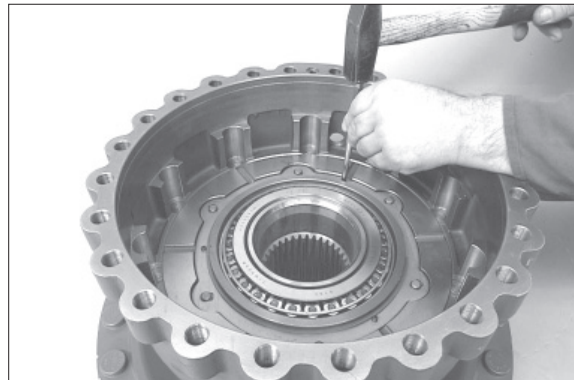

7577AAXF057

To the sketch :

- 1 Brake housing
- 2 Circlip
- 3 Slotted pin
- 4 Support shim
- 5 Piston
- X Installation dimension $4.0_{-0,5}$ mm

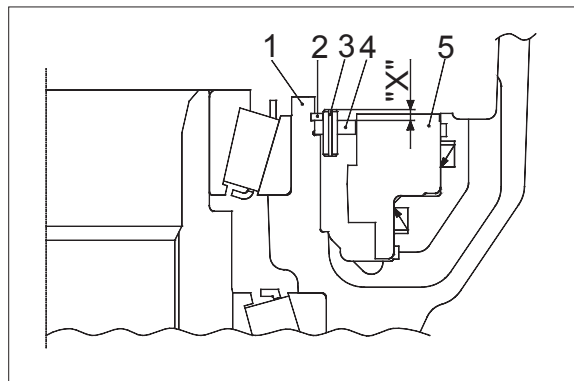

7577AAXF058

(19) Drive stop bolt into the planet carrier until contact.

Then wet spline (see arrow).

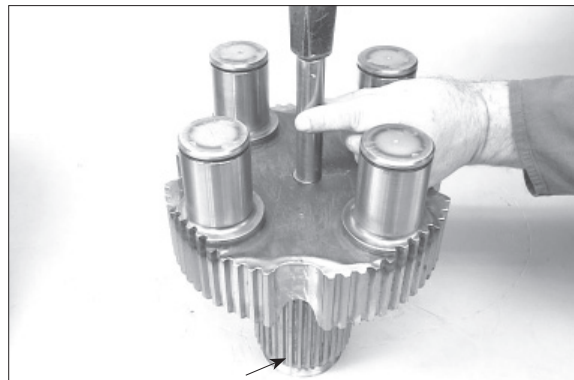

7577AAXF059

(20) Insert planet carrier into the spline of the output shaft until contact.

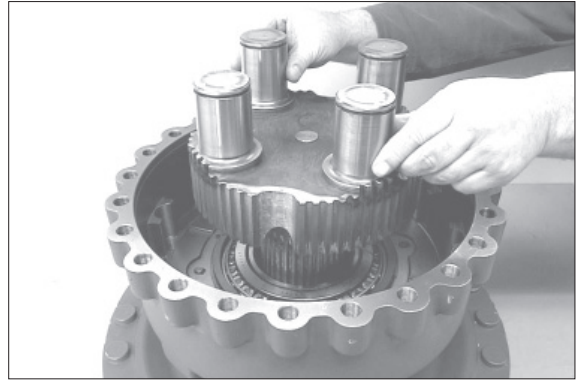

7577AAXF060

(21) Install outer-and inner clutch discs alternately starting with an outer clutch disc.

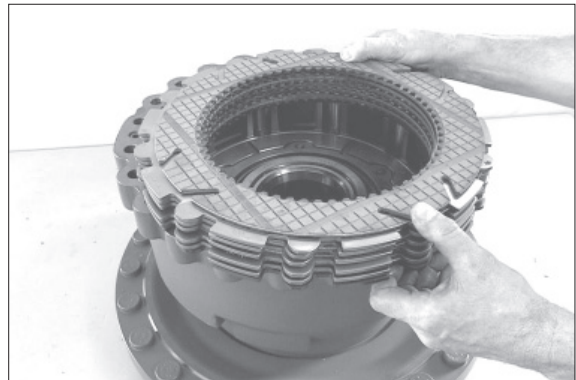

7577AAXF061

(22) Insert O-ring (see arrow) into the recess of the brake housing.

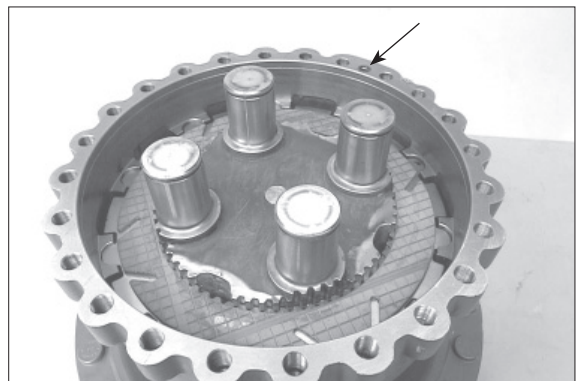

7577AAXF062

(23) Grease both O-rings (see arrows) and insert them into the annular grooves of the ring gear.

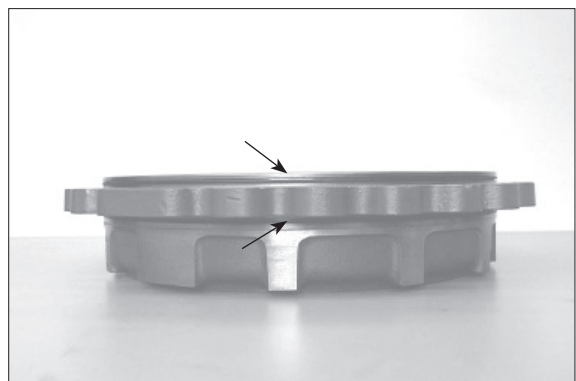

7577AAXF017

(24) Install two adjusting screws and insert ring gear into the brake housing until contact.

※ Special tool

Adjusting screws 5870 204 029

※ Pay attention to radial location.

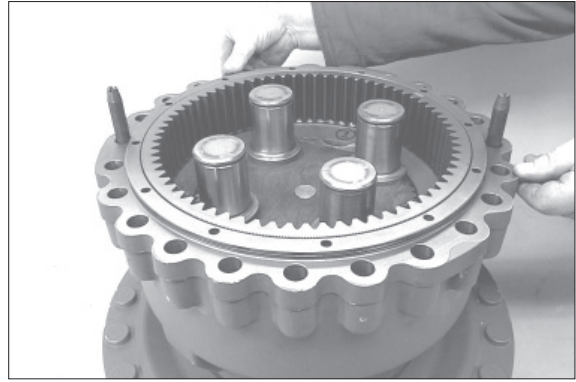

7577AAXF063

(25) Heat bearing inner rings and install them until contact with the big radius showing to the planet carrier (downwards).

※ Subsequently install bearing inner rings after cooling down.

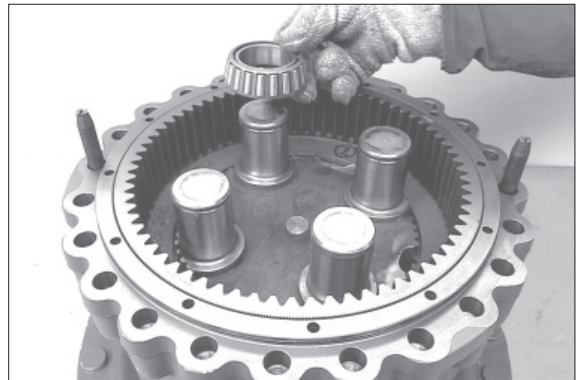

7577AAXF064

(26) Put planet gears onto the bearing inner rings.

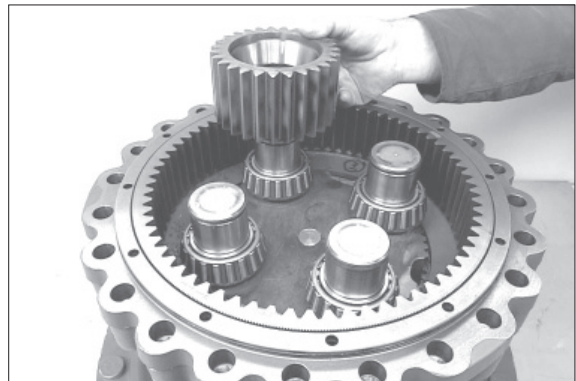

7577AAXF065

(27) Heat bearing inner rings and install them on the planet gears until contact.

※ Subsequently install bearing inner rings after cooling down.



7577AAXF066

(28) Fasten plant gears by means of retaining rings.

- ※ Special tool
- Set of external pliers 5870 900 015



7577AAXF067

Adjust end play of sun gear shaft 0.5 ~ 2.0 mm

(29) Fasten ring gear by means of cap screws until contact.

Then determine dimension I, from the mounting face of the ring gear up to the face of the stop bolt.

Dimension I e.g 46.20 mm

- ※ Special tool
- Digital depth gauge 5870 200 072
- Gauge blocks 5870 200 066
- Straightedge 5870 200 022

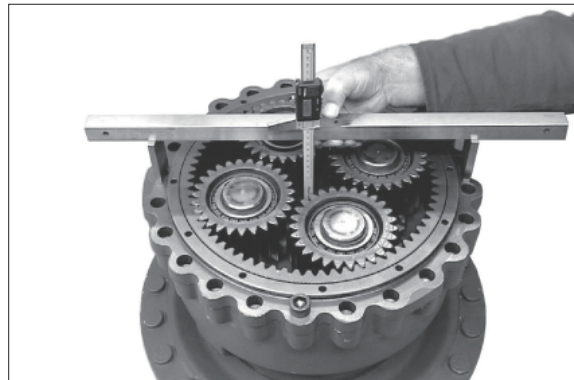

7577AAXF068

(30) Insert stub shaft into spline of the axle bevel gear until contact.

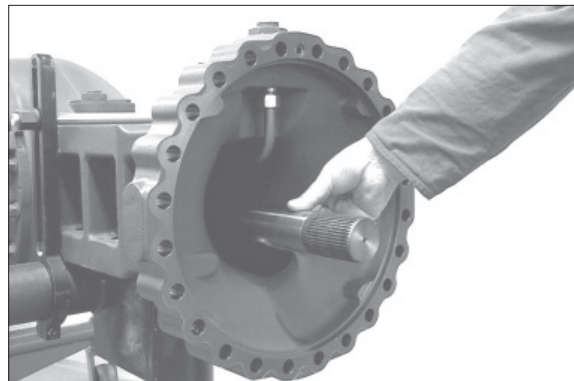

7577AAXF069

(31) Assemble sun gear shaft until contact.

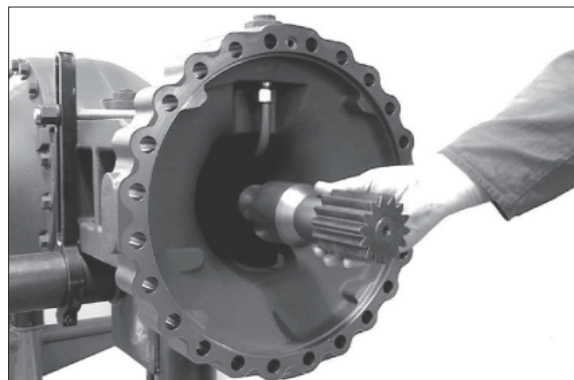

7577AAXF070

(32) Determine Dimension II from the face of the sun gear shaft up to the mounting face of the axle casing.

Dimension II e.g. 43.00 mm

※ Special tool

Digital depth gauge 5870 200 072

Gauge blocks 5870 200 066

Straightedge 5870 200 022

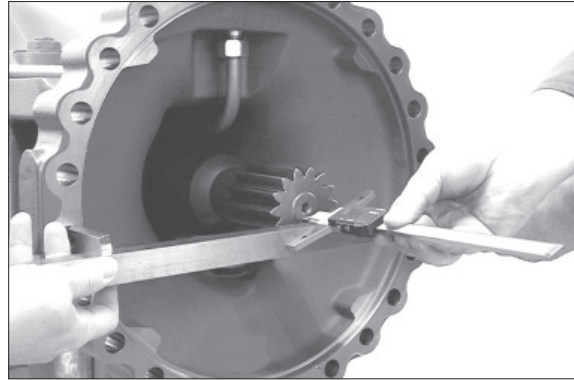

7577AAXF071

EXAMPLE A :

Dimension I 46.20 mm

Dimension II - 43.00 mm

Difference 3.20 mm

required end play e.g. - 1.00 mm

Difference = shim e.g. s = 2.20 mm

(33) Insert sun gear shaft into the planet carrier.

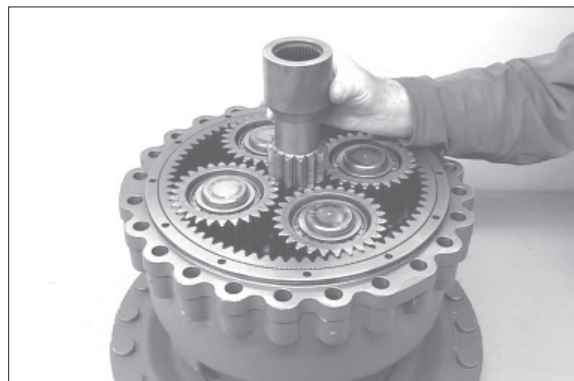

7577AAXF072

(34) Fix determined shim (s), e.g. $s = 2.20$ mm, into the sun gear shaft by means of grease.



7577AAXF073

(35) Fix O-ring (see arrow) into the recess of the axle casing by means of grease and install the preassembled output to the axle casing until contact by means of lifting tackle.

※ Special tool

Lifting bracket 5870 281 043

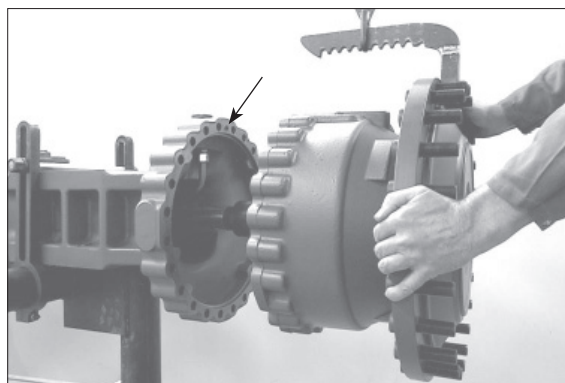

7577AAXF074

(36) Fasten output by means of hexagon screws and washers.

· Tightening torque (M18/10.9) :

39.8 kgf · m (288 lbf · ft)

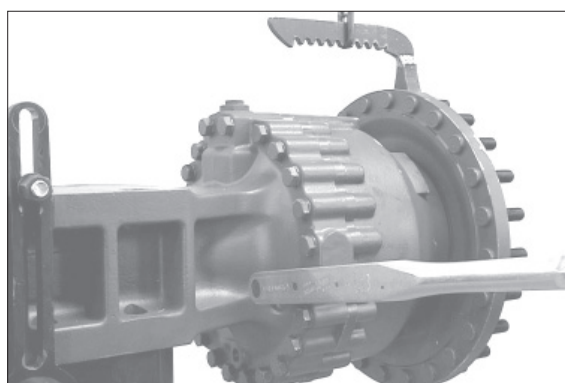

7577AAXF075

(37) Unscrew slotted nut by hand and then fasten it.

· Tightening torque : $153^{+20.4}$ kgf · m
(1107^{+148} lbf · ft)

※ Special tool

Socket spanner 5870 656 078

Centering bracket 5870 912 028

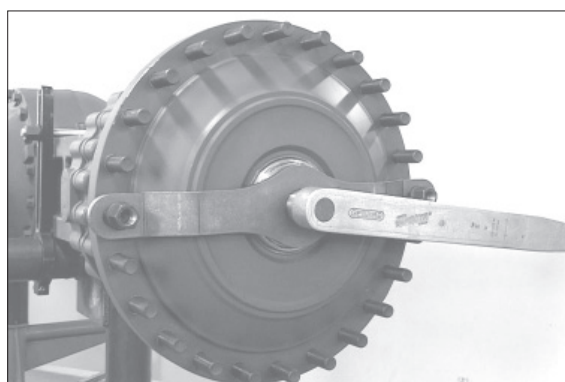

7577AAXF076

(38) Secure slotted nut by means of slotted pin.



7577AAXF077

(39) Assemble O-ring (see arrow) to the cover.



(40) Insert cover into the output shaft until contact.

- ※ Special tool
Hammer (plastic $\varnothing 60$) 5870 280 004



7577AAXF079

Leakage test of the brake hydraulics

- ※ Prior to start the test, ventilate the brake hydraulics completely.

- 1) Open the bleeder.
- 2) Slowly actuate the HP-pump until oil flows out of the bleeder.
- 3) Close the bleeder again.
- 4) Slowly pressurize the HP-pump with $p > 10$ bar and hold the pressure for some seconds.

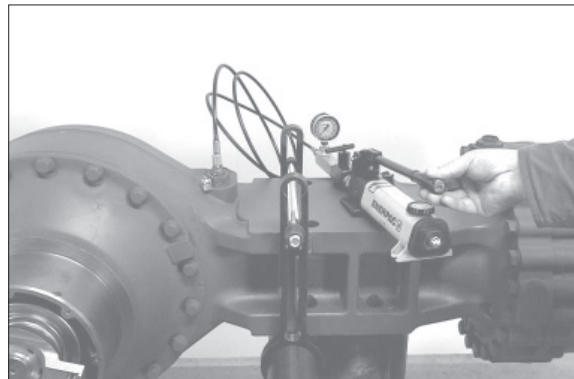

- ※ The brake piston extends and the cylinder chamber fills up with oil. The air accumulates in the upper section of the cylinder chamber.
- 5) Loosen the shut-off valve on the HP-pump.
 - ※ The reversing piston presses the air from the upper section of the cylinder into the brake line.
 - 6) Open the bleeder again.
 - 7) Slowly actuate the HP-pump until oil flows out of the bleeder.
- ※ Repeat procedure - Item 3)~7) until at 7) from the beginning of the actuation no more air exits from bleeder.
 - ※ Then pressurize the brake temporarily (5EA) with $p = 100$ bar max..

3) DISASSEMBLY OF DIFFERENTIAL CARRIER AND BRAKE TUBES

(1) Disassembly of differential carrier

① Fasten axle on assembly truck.

※ Special tool

Assembly truck 5870 350 000

Holding fixtures 5870 350 077

Clamps 5870 350 075

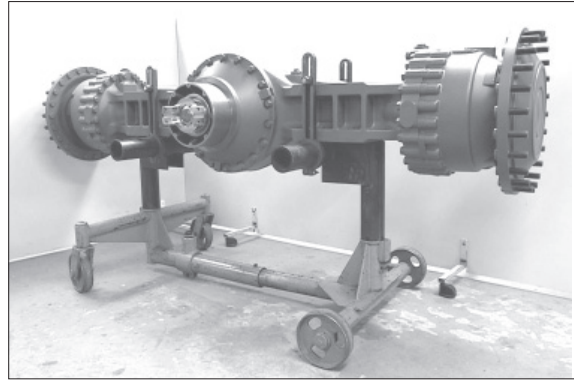

7577AAXF001

② Loosen screw plugs (3EA, see Figure 7577AAXF002 and 003) and drain oil from axle casing.

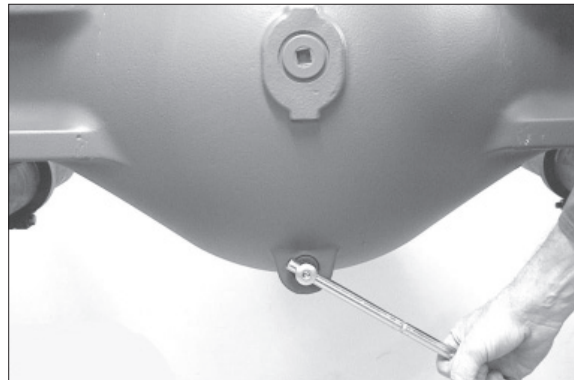

7577AAXF002

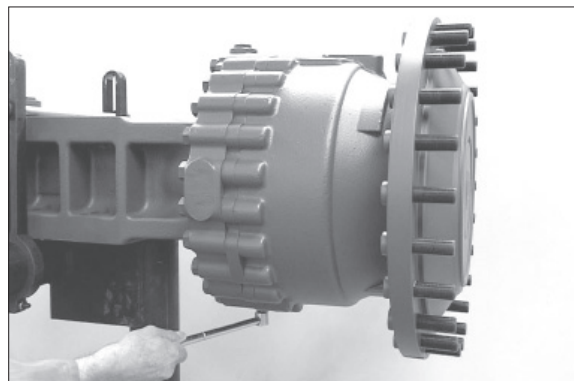

7577AAXF003

③ Secure output by means of lifting tackle and loosen hexagon screws.

※ Special tool

Lifting bracket 5870 281 043

※ Make step (Fig. 7577AAXF007~9) on both output sides.

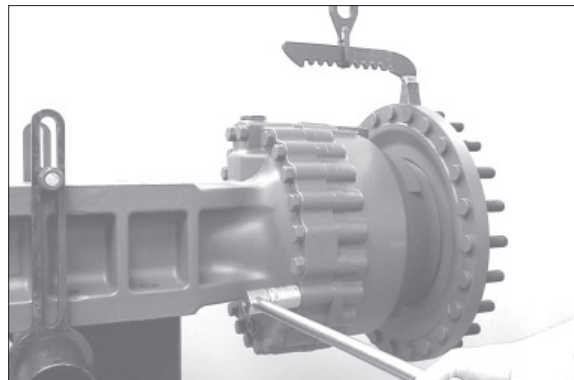

7577AAXF007

④ Separate complete output from the axle casing.

※ Pay attention to released O-ring (see arrow).

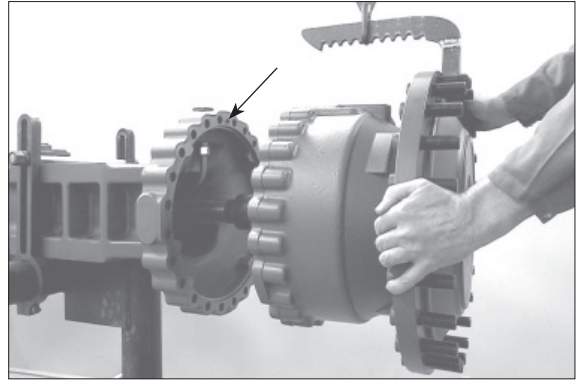

7577AAXF008

⑤ Pull stub shaft out of the sun gear shaft.

※ Pay attention to released shim (s).

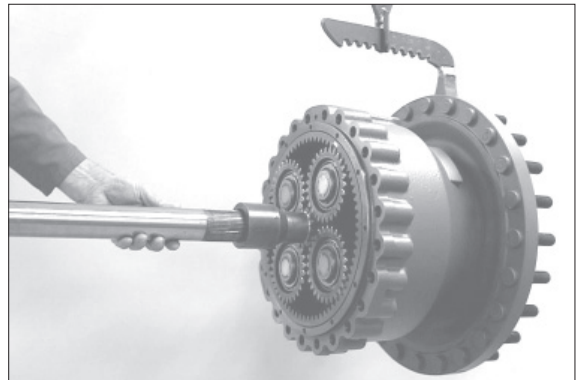

7577AAXF009

⑥ Loosen hexagon screws.

※ Mark location of differential carrier to the axle casing (see arrows).

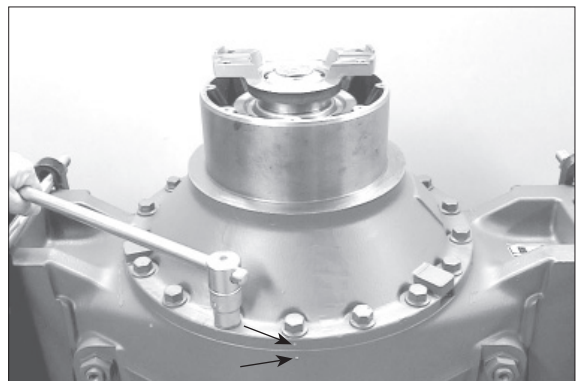

7577AAXF081

⑦ Lift differential carrier by means of lifting tackle out of the axle casing.

※ Special tool

Lifting tackle

5870 281 044

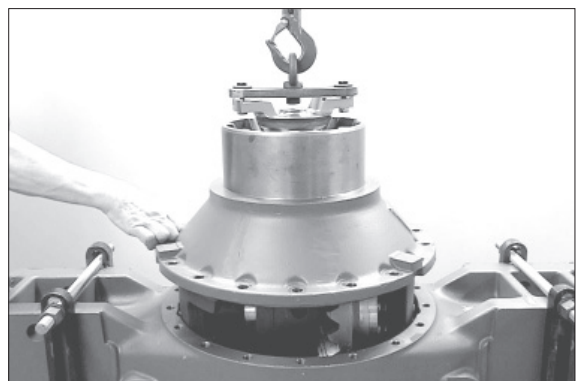

7577AAXF082

⑧ Fasten differential carrier to assembly truck.

※ Special tool

Assembly truck 5870 350 000

Holding fixture 5870 350 034

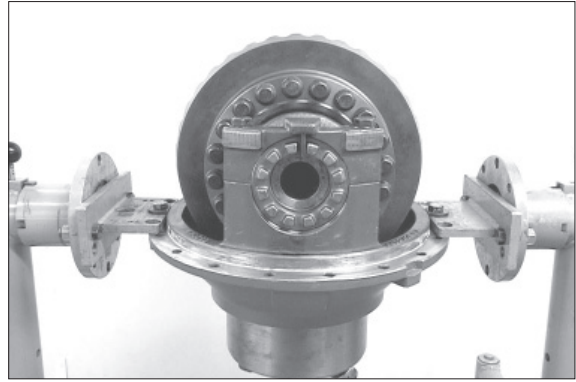

7577AAXF083

⑨ Drive out slotted pins.

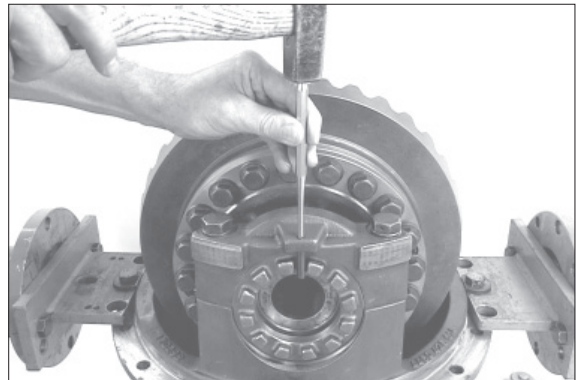

7577AAXF084

⑩ Loosen and remove both adjusting nuts.

※ Special tool

Socket spanner 5870 656 079

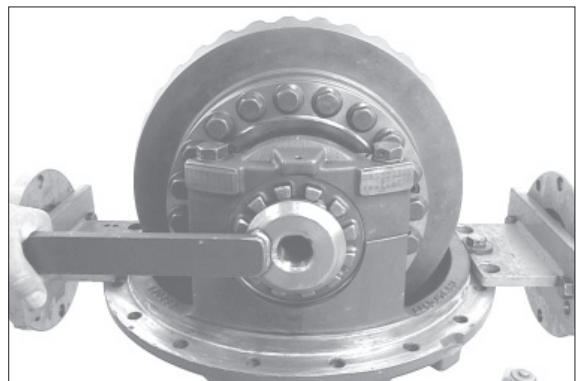

7577AAXF085

⑪ Heat axle drive housing by means of hot-air blower.

※ Special tool

Hot-air blower 230 V 5870 221 500

Hot-air blower 115 V 5870 221 501

※ Hexagon screws are installed with Loctite (type No. 262).

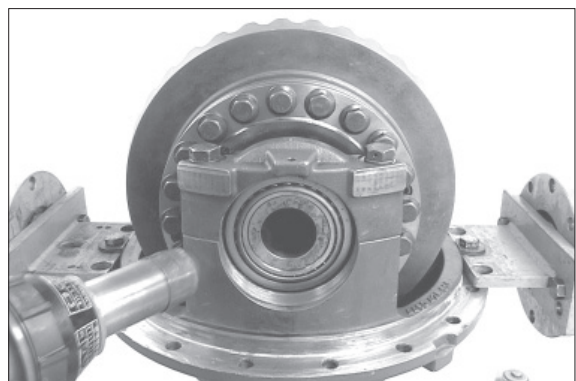

7577AAXF086

⑫ Loosen hexagon screws and take off bearing bracket.

▲ Loosen hexagon screws by hand only.

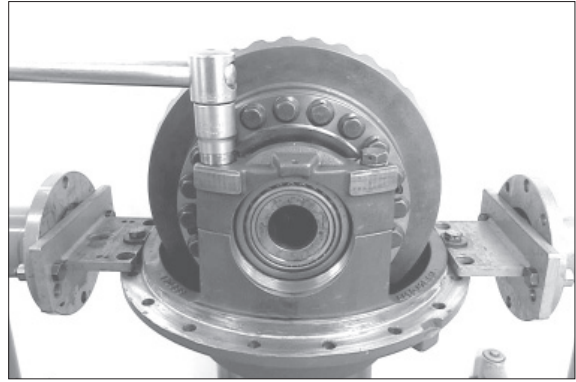

7577AAXF087

⑬ Remove both bearing outer rings.

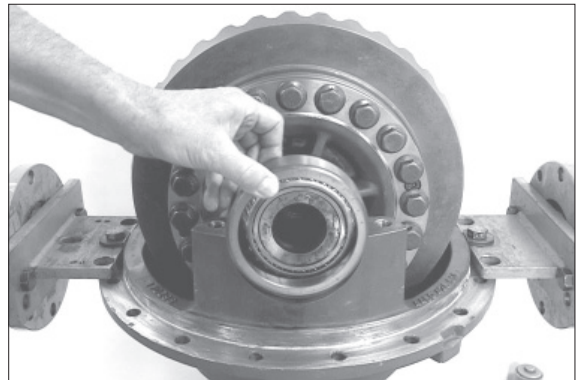

7577AAXF088

⑭ Lift differential out of the housing by means of lifting tackle.

※ Special tool
Lifting tackle 5870 281 013

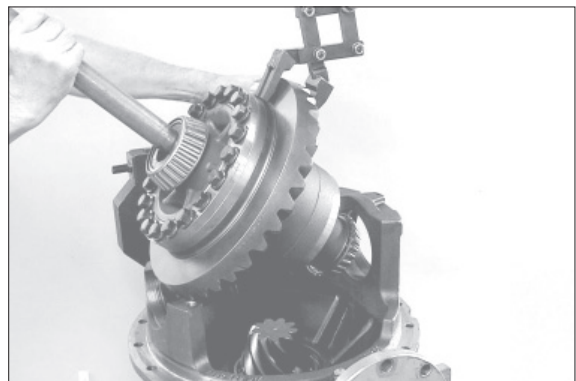

7577AAXF089

Disassembly of limited slip differential

⑮ Pull bearing inner ring from the differential housing.

※ Special tool
Gripping insert 5873 002 023
Basic set 5873 002 001

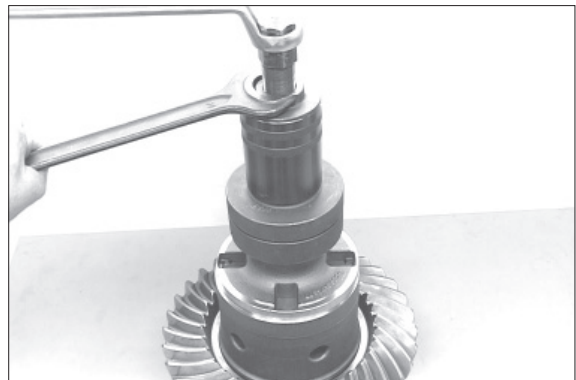

7577AAXF090

- ⑩ Pull bearing inner ring from the housing cover.

※ Special tool

Rapid grip

5873 012 018

Basic set

5873 002 001

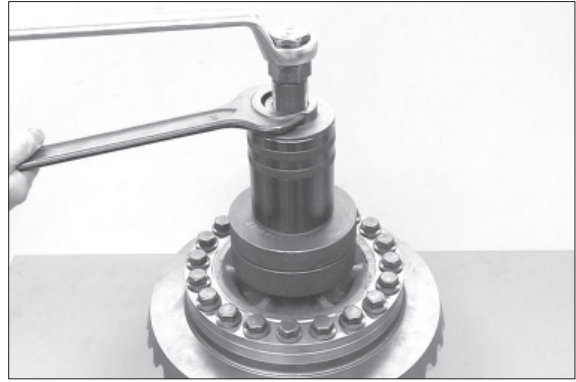

7577AAXF091

- ⑪ Fasten differential by means of press and loosen locking screws.

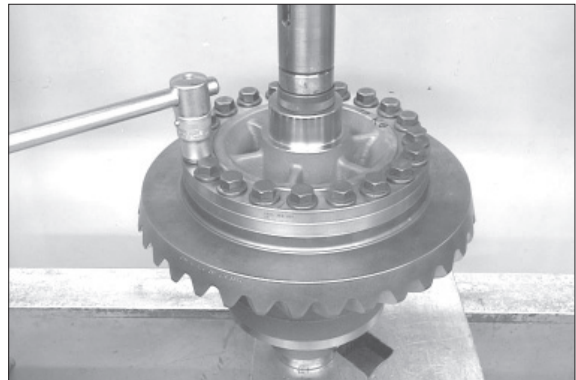

7577AAXF092

- ⑫ Loosen cap screws and remove released housing cover.

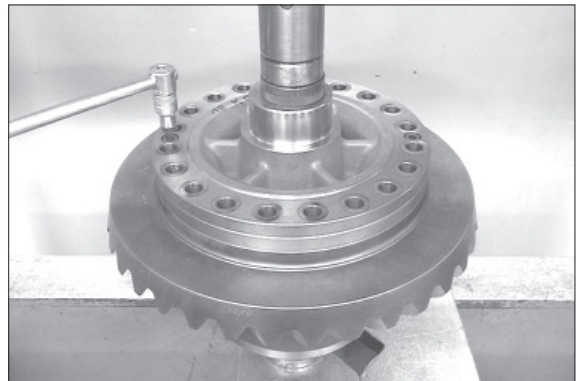

7707AAXR001

- ⑬ Remove all single parts from the differential housing.

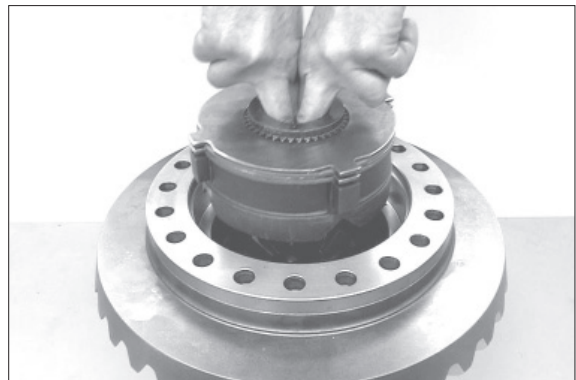

7577AAXF093

- ⑳ Press off crown wheel from the differential housing.

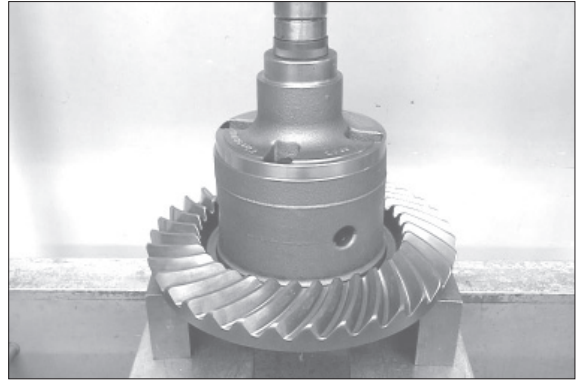

7577AAXF094

Disassembly of drive pinion

- ㉑ Heat slotted nut by means of hot-air blower.

※ Special tool

Hot-air blower 230 V 5870 221 500

Hot-air blower 115 V 5870 221 501

※ Slotted nut is locked with Loctite (type No. 262).

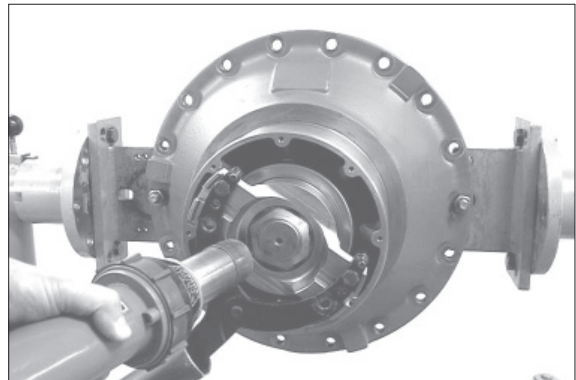

7577AAXF095

- ㉒ Loosen slotted nut and remove the washer behind it.

※ Special tool

Slotted nut wrench 5870 401 139

Fixture 5870 240 002

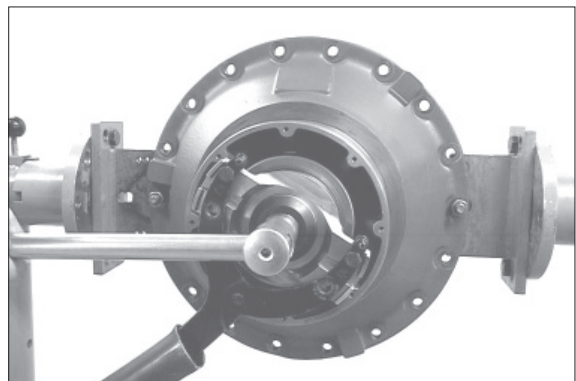

7577AAXF096

- ㉓ Pull input flange from the drive pinion.

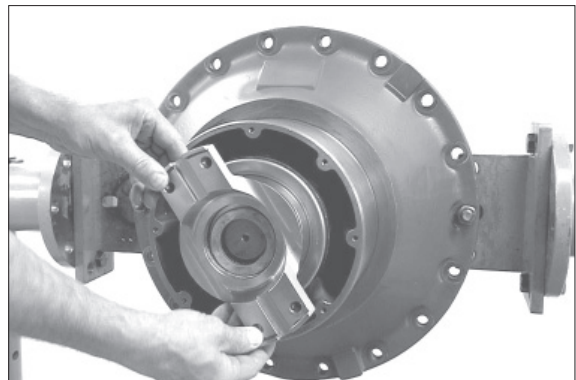

7577AAXF097

- ②④ Press shaft seal out of the axle drive housing.

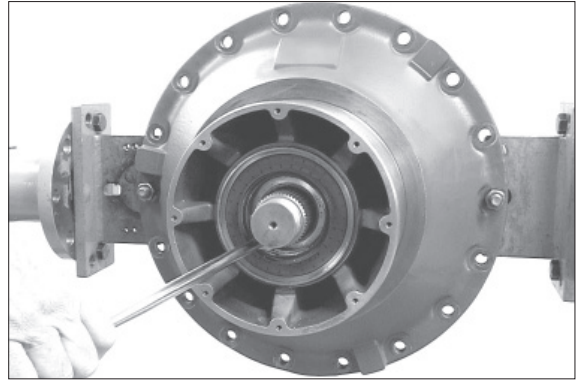

7577AAXF098

- ②⑤ Press drive pinion out of the axle drive housing by means of two-armed puller and remove the released bearing inner ring.

- ※ Special tool
Two-armed puller 5870 970 007

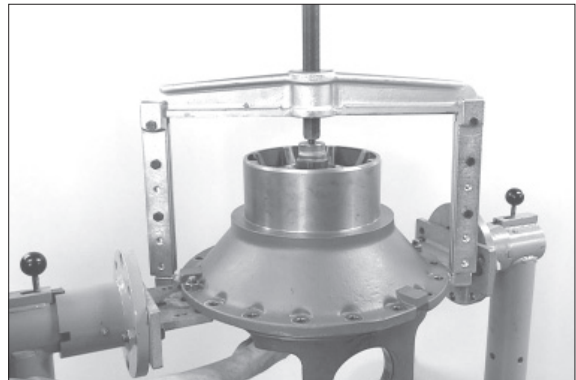

7577AAXF099

- ②⑥ Take off spacer ring and pull bearing inner ring from the drive pinion.

- ※ Special tool
Gripping insert 5873 002 032
Basic set 5873 002 001



7577AAXF100

- ②⑦ If necessary drive out both bearing outer rings from the axle drive housing.

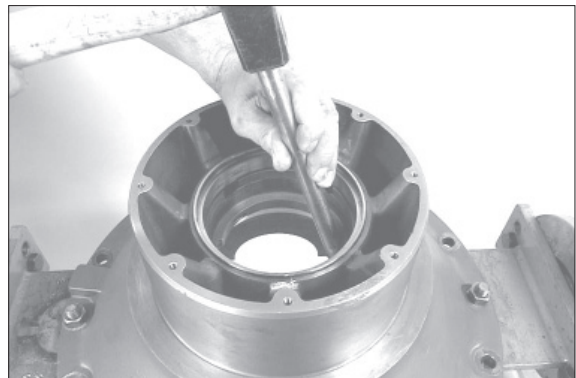

7577AAXF101

(2) Disassembly of brake tubes

- ① Remove screw plug with vent valve from the axle casing.

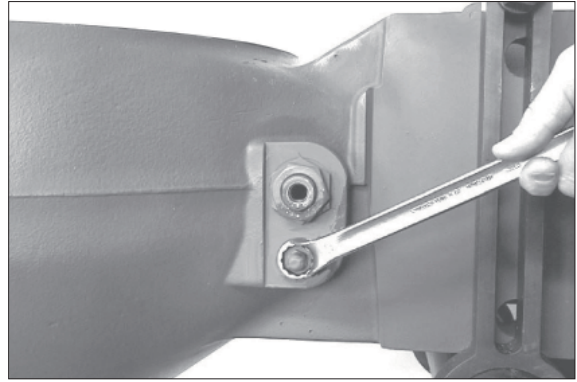

7577AAXF102

- ② Loosen hexagon nut.

※ Step (Figure 7577AAXF103~107) to be made on both sides.

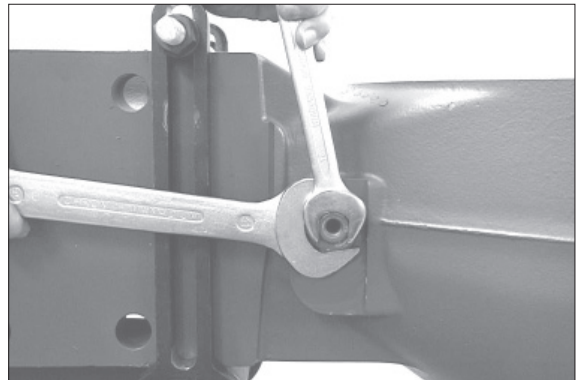

7577AAXF103

- ③ Loosen union screw.

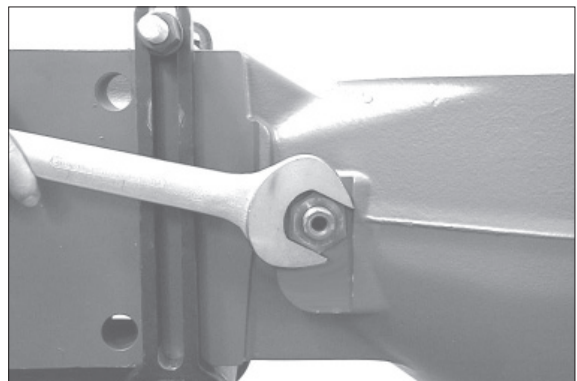

7577AAXF104

- ④ Loosen pipe union and remove released brake tube from the axle casing.

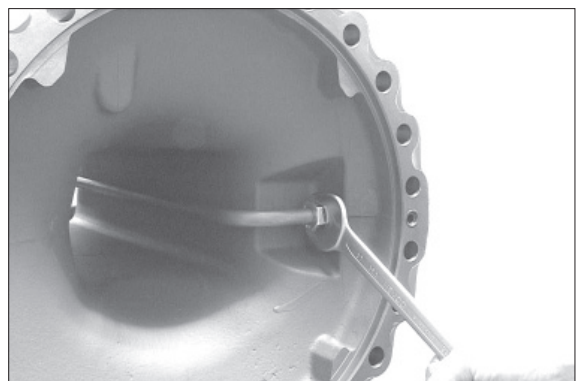

7577AAXF105

- ⑤ Remove vent valve from the connection part.

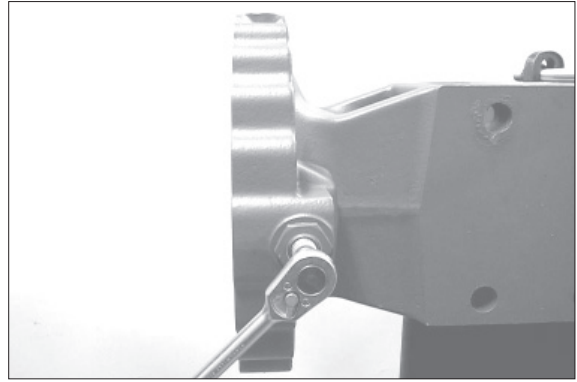

7577AAXF106

- ⑥ Loosen connection part and remove it from the axle casing.

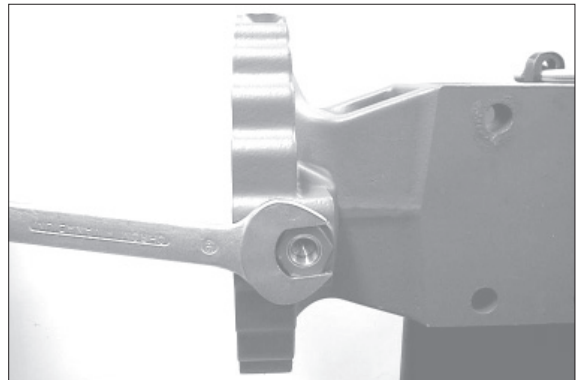

7577AAXF107

4) REASSEMBLY OF BRAKE TUBES AND DIFFERENTIAL CARRIER

(1) Reassembly of brake tubes

① Preassemble connection part as shown in opposite figure.

- 1 Vent valve
- 2 Connection part
- 3 O-Ring
- 4 Rectangular ring

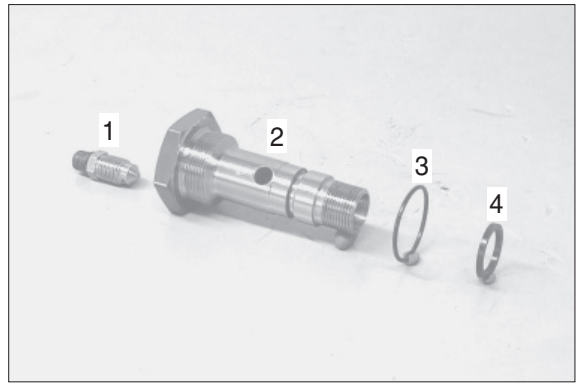

7577AAXF108

※ Step (Figure 7577AAXF108~114) is to be made on both output sides.

② Install connection part.

- Tightening torque : 13.3 kgf · m
(95.9 lbf · ft)

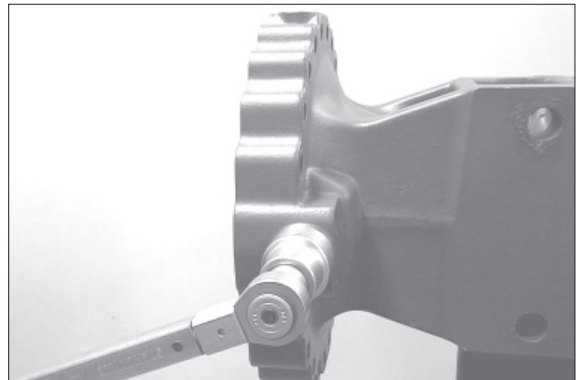

7577AAXF109

③ Provide union screw with new O-ring and install it.

- Tightening torque : 15.3 kgf · m
(111 lbf · ft)

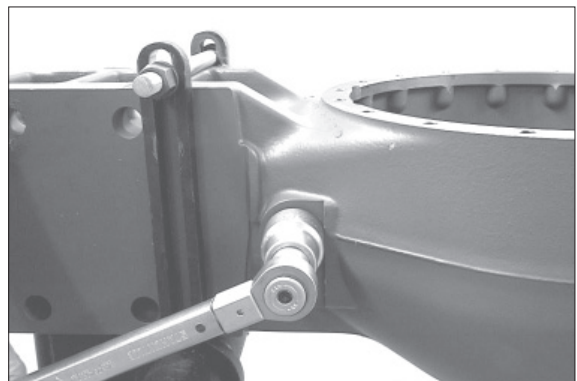

7577AAXF110

④ Insert O-ring (see arrow) into the annular groove of the brake tube.



7577AAXF111

- ⑤ Insert brake tube into the axle casing, assembling the connection part (see arrow 1) through the union screw (see arrow 2).

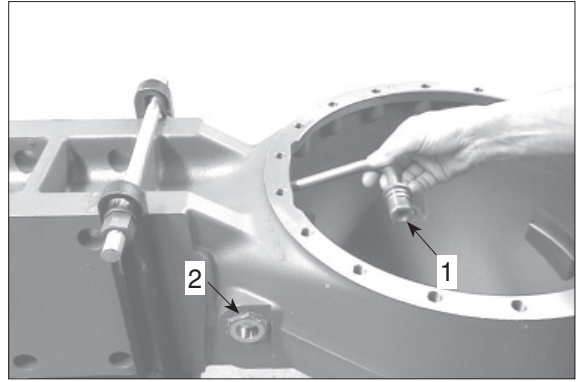

7577AAXF112

- ⑥ Fasten brake tube by means of hexagon nut and union nut (see below figure).

- Tightening torque : 10.2 kgf · m
(73.8 lbf · ft)

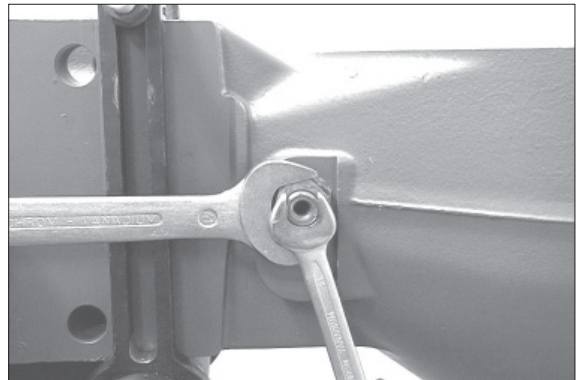

7577AAXF113

- Tightening torque : 8.2 kgf · m
(59 lbf · ft)

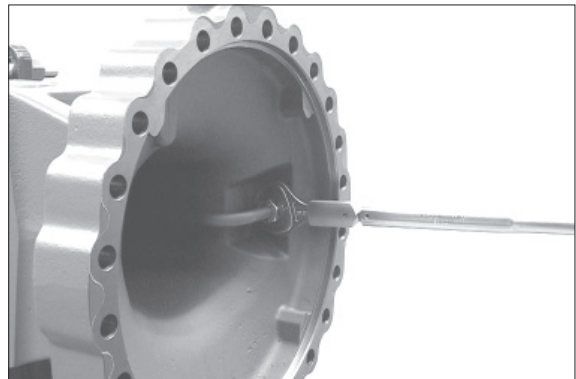

7577AAXF114

- ⑦ Preassemble screw plug as shown in opposite figure.

- 1 O-Ring
- 2 Screw plug
- 3 Vent valve

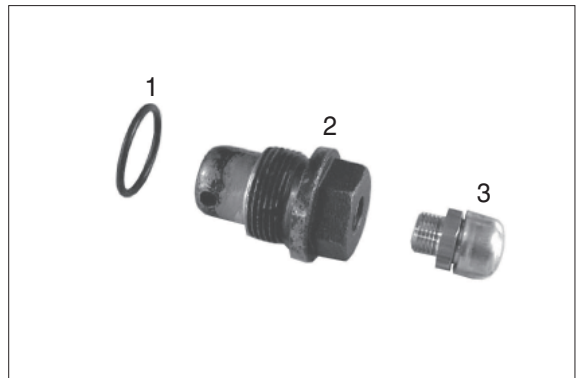

7577AAXF115

⑧ Install screw plug.

- Tightening torque : 7.1 kgf · m
(51.6 lbf · ft)

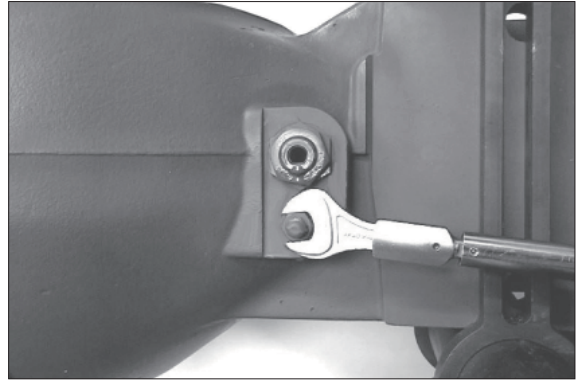

7577AAXF116

(2) Reassembly of differential carrier

※ If crown wheel or drive pinion are damaged, both parts have to be replaced together.

For new installation of a complete bevel gear set pay attention to the same pair number of drive pinion and crown wheel.

Determine shim thickness for a perfect tooth contact pattern

※ Make the following measuring steps at maximum accuracy.

Inexact measurements result in a faulty tooth contact pattern and require a repeated disassembly and reassembly of the drive pinion as well as of the differential.

① Install adapter pieces (1) and preliminarily fasten the bearing bracket by means of hexagon screws.

Then install stop washer (4) and measuring pin (3) and assemble measuring shaft (2) (see sketch).

※ Special tool

Adapter pieces	5870 500 044
Measuring shaft	5870 500 001
Measuring pin	5870 351 016
Stop washer	5870 351 029

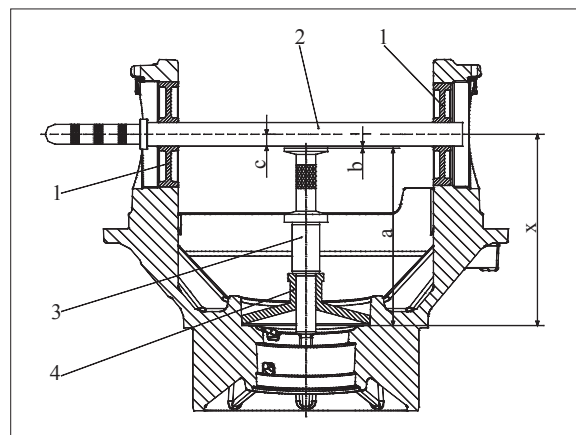

7577AAXF117

② Determine gap (dimension b) between measuring shaft and measuring pin by means of feeler gauge.

Dimension b e.g. 0.20 mm

EXAMPLE A :

Dimension a (= Measuring pin + stop washer) 206.00 mm
 Dimension b + 0.20 mm
 Dimension c + 15.00 mm
results in dimension X = 221.20 mm

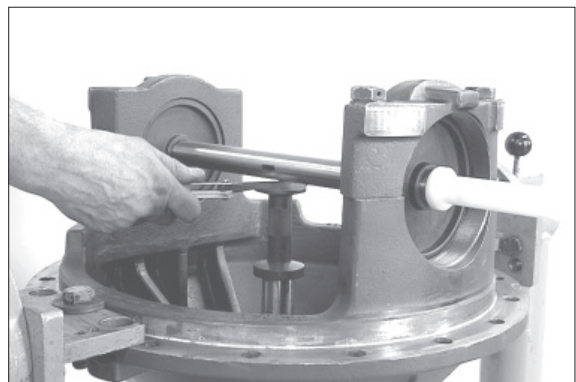

7577AAXF118

③ Determine dimension I (bearing width).

Dimension I e.g. 39.05 mm

※ Special tool

Digital depth gauge 5870 200 072

Gauge blocks 5870 200 066

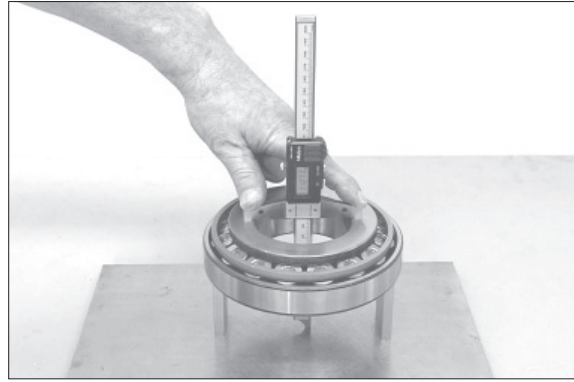

7577AAXF119

④ Read dimension II (dimension for pinion).

Dimension II e.g. 181.05 mm

EXAMPLE B :

Dimension I 39.05 mm

Dimension II + 181.05 mm

results in dimension Y = 220.10 mm

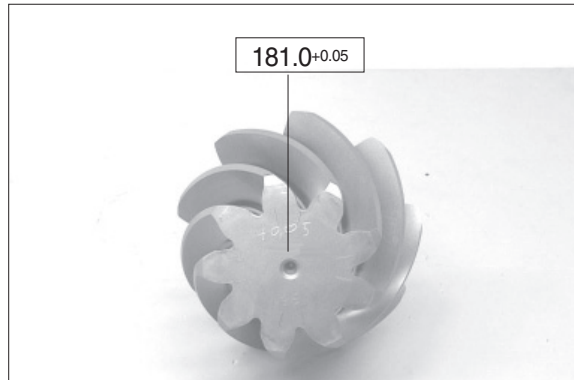

7577AAXF120

EXAMPLE C :

Dimension X 221.20 mm

Dimension Y - 220.10 mm

Difference = shim e.g. s = 1.10 mm

Install the drive pinion

⑤ Place determined shim e.g. s = 1.10 mm into the bearing bore.

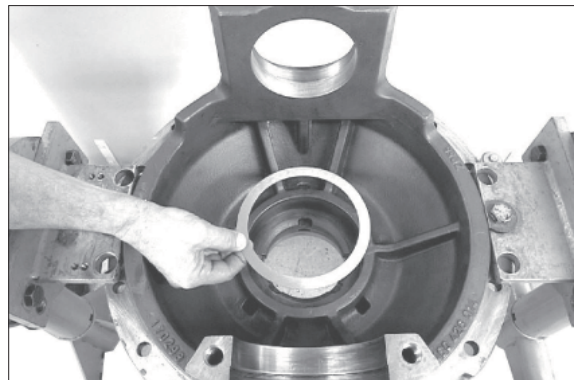

7577AAXF121

- ⑥ Undercool bearing outer ring and insert it into the bearing bore until contact.

※ Special tool

Driver 5870 058 060

Handle 5870 260 002

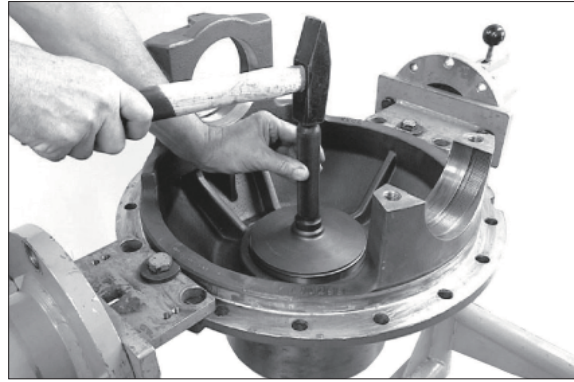

7577AAXF122

- ⑦ Undercool bearing outer ring on the input flange side and insert it until contact.

※ Special tool

Driver 5870 058 079

Handle 5870 260 002



7577AAXF123

- ⑧ Press bearing inner ring on the drive pinion until contact.

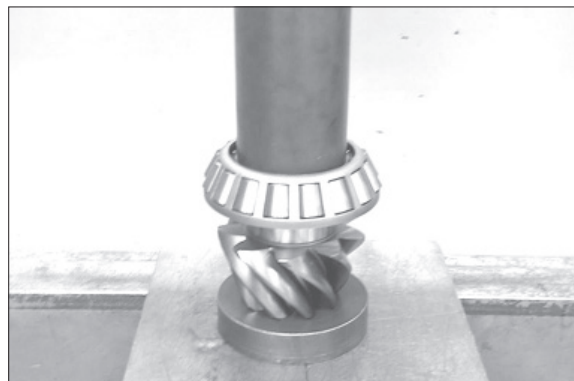

7577AAXF124

Adjust rolling moment of drive pinion bearing 0.15 ~ 0.31kgf · m (Figure 7577AAXF125~133) :

- ⑨ Assemble spacer ring (e.g. s = 8.10 mm).

※ As per experience the required rolling moment is obtained by use of the spacer ring (e.g. s = 8.10 mm) available at disassembly.

However, a later checking of the rolling moment is imperative.

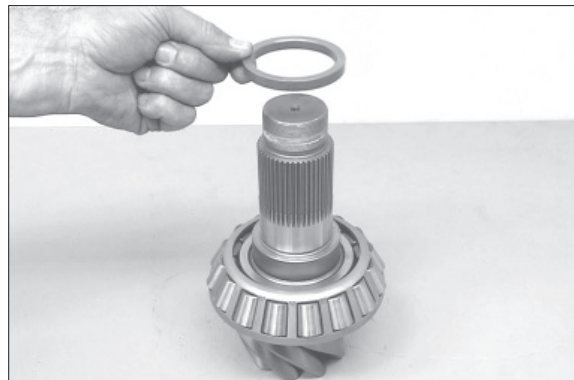

7577AAXF125

- ⑩ Insert preassembled drive pinion into the axle drive housing and assemble the heated bearing inner ring until contact.

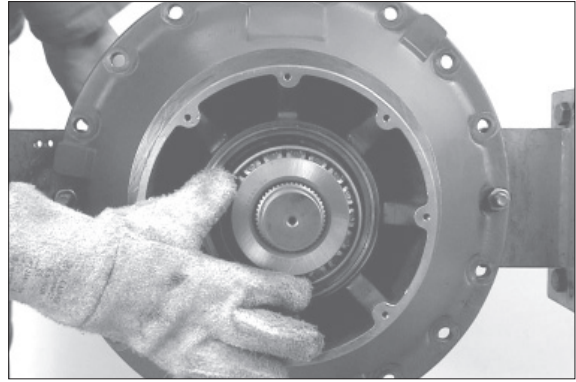

7577AAXF126

- ⑪ Press dust protection on the input flange until contact.

※ Special tool
Driver

5870 056 003

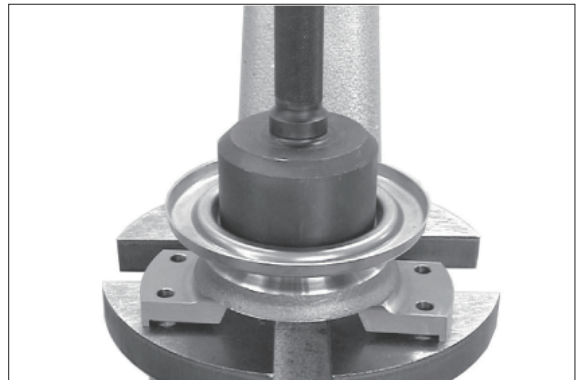

7577AAXF127

- ⑫ Assemble input flange.

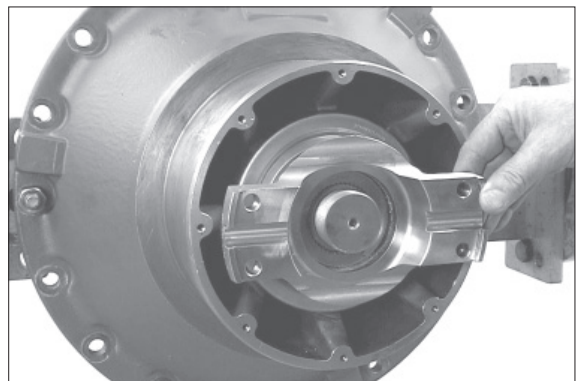

7577AAXF128

- ⑬ Assemble washer.

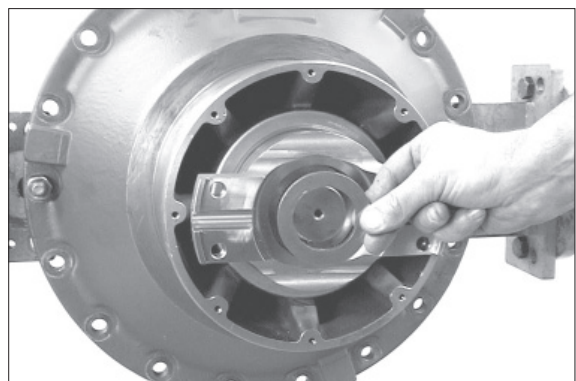

7577AAXF129

- ⑭ Unscrew hexagon nut by hand and tighten it.

· Tightening torque : 122 kgf · m
(885 lbf · ft)

※ Special tool

Slotted nut wrench 5870 401 139

Fixture 5870 240 002

※ When tightening rotate drive pinion in both directions several times.

- ⑮ Check rolling moment (0.15~0.30 kgf · m).

※ For new bearings it should be tried to achieve the max. value of the rolling moment.

▲ If the required rolling moment is not obtained, correct it with an adequate spacer ring (Figure 7577AAXF125), according to the following indications :

Rolling moment too low - install a thinner spacer ring

Rolling moment too high - install a thicker spacer ring.

Then loosen the slotted nut again and pull input flange from the drive pinion.

- ⑯ Install shaft seal with the sealing lip showing to the oil chamber (downwards).

Special tool

※ Driver 5870 048 233

※ The exact installation position of the shaft seal will be obtained by using the exact driver.

▲ Just before the installation wet the outer diameter of the shaft seal with spirit and fill the space between sealing and dust lip with grease.

- ⑰ Assemble input flange and finally fasten it by means of washer and slotted nut.

· Tightening torque : 122kgf · m(885lbf · ft)

▲ Apply Loctite (type No. 262) onto the thread of the slotted nut.

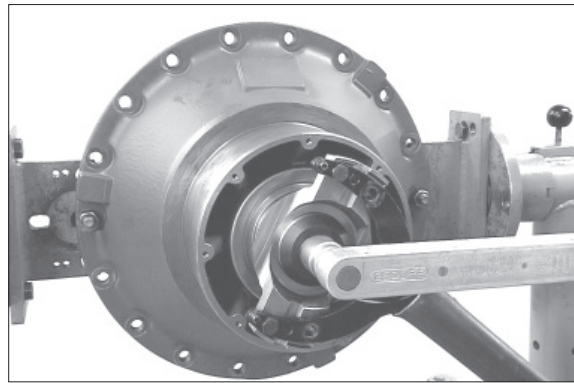

7577AAXF130

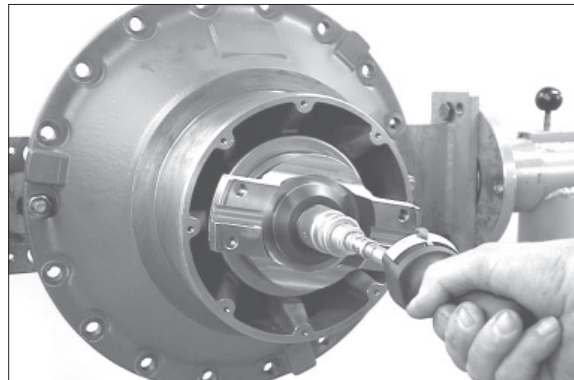

7577AAXF131



7577AAXF132

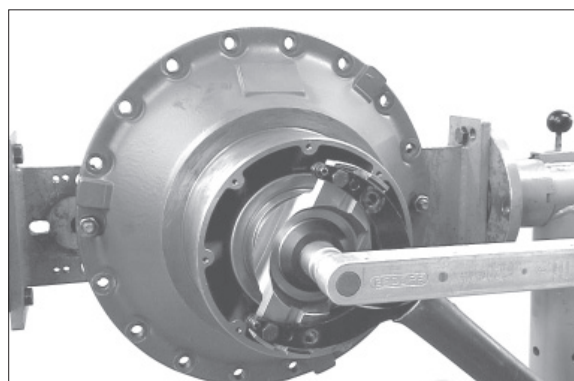

7577AAXF133

Reassembly of limited slip differential

- ⑱ Place both thrust washers into the differential housing.
- ※ Prior to installation all single parts of the differential must be oiled.

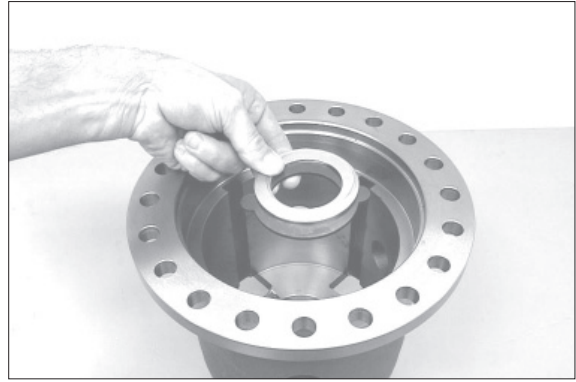

7577AAXF134

- ⑲ Starting with an outer clutch disc install alternately the outer and inner clutch discs.

▲ **Thickness of the disc pack must be identical on both sides.**

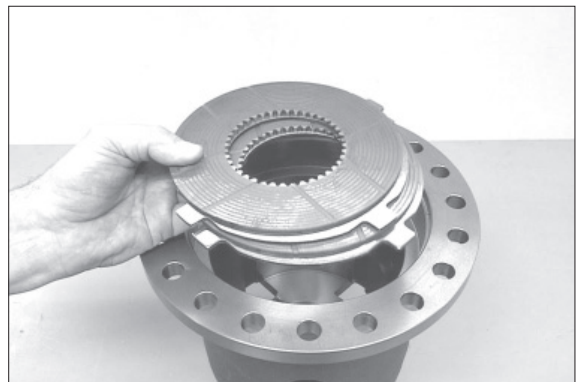

7577AAXF135

- ⑳ Put on the pressure ring.

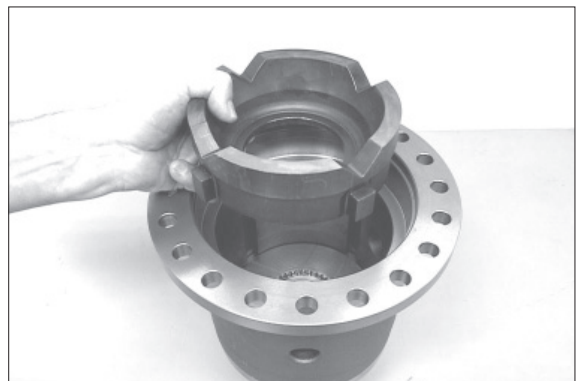

7577AAXF136

- ㉑ Insert axle bevel gear until contact and at the same time assemble all inner clutch discs with the spline.

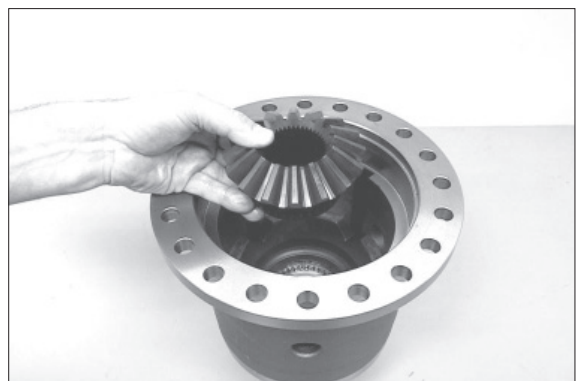

7577AAXF137

- ② Preassemble differential spider and insert it into the differential housing.

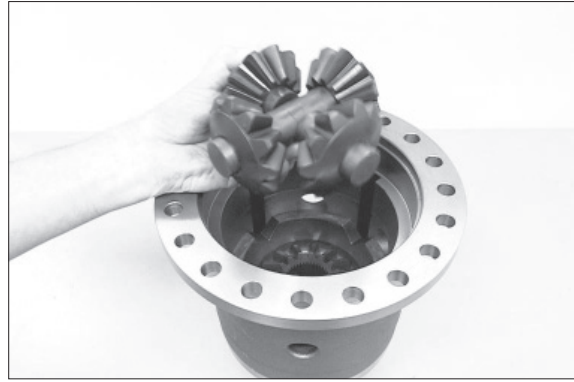

7577AAXF138

- ③ Put on the second axle bevel gear.

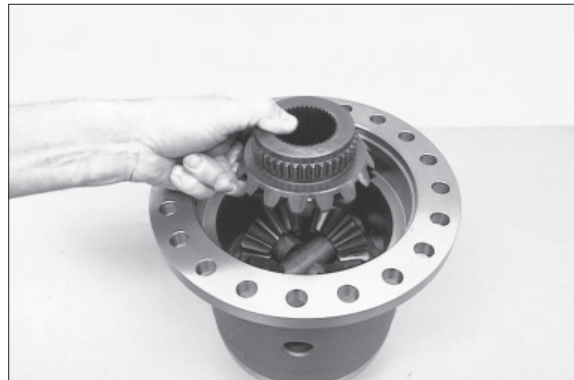

7577AAXF139

- ④ Insert the second pressure ring into the differential housing.

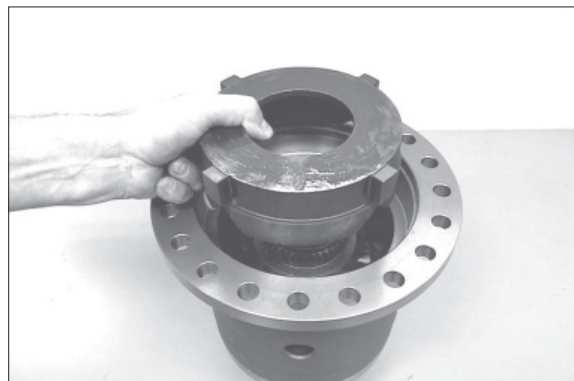

7577AAXF140

- ⑤ Starting with an inner clutch disc install alternately the inner and outer clutch discs.

- ▲ Thickness of the clutch disc pack must be identical on both sides.

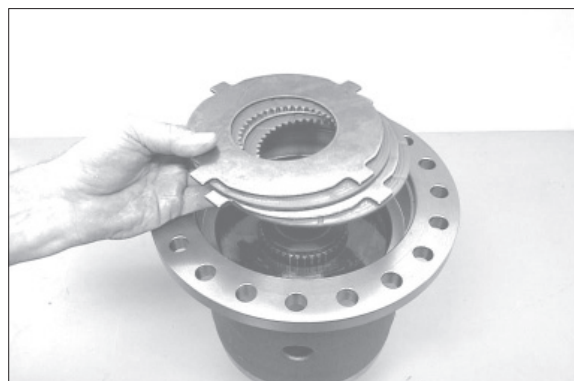

7577AAXF141

Determine disc clearance 0.2~0.8 mm

- ②⑥ Determine dimension I, from mounting face of the differential housing to plane face of the outer clutch disc.

Dimension I e.g 44.30 mm

※ Special tool

Digital depth gauge 5870 200 072

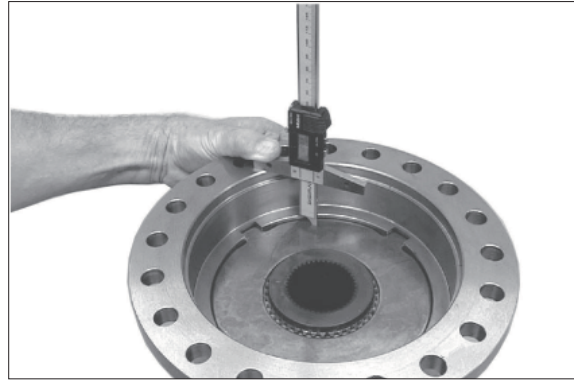

7577AAXF142

- ②⑦ Determine dimension II, from contact surface of the outer clutch disc to the mounting face of the housing cover.

Dimension II e.g 43.95 mm

EXAMPLE D :

Dimension I 44.30 mm

Dimension II - 43.95 mm

Difference = Disc clearance = 0.35 mm.

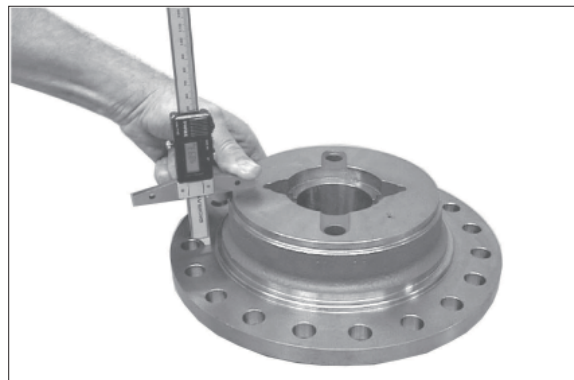

7577AAXF143

※ If the required disc clearance is not obtained, correct it with the adequate outer clutch discs (s = 2.7, s = 2.9, s = 3.0, s = 3.1 or s = 3.3 mm), taking care that the difference in thickness between the left and the right disc pack must only be 0.01 at a maximum.

- ②⑧ Fix both thrust washers with grease into the recess of the housing cover.

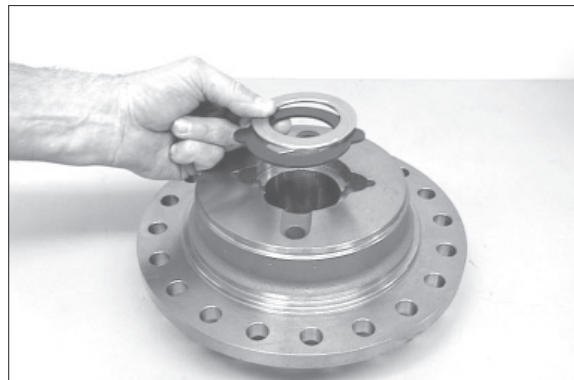

7577AAXF144

- ②⑨ Put on the housing cover and fasten it by means of cap screws (2EA).
- Tightening torque (M10/8.8) :
4.7 kgf · m (33.9 lbf · ft)



7707AAXF015

- ③⑩ Heat crown wheel and install it until contact.
- ※ Special tool
Adjusting screws 5870 204 040

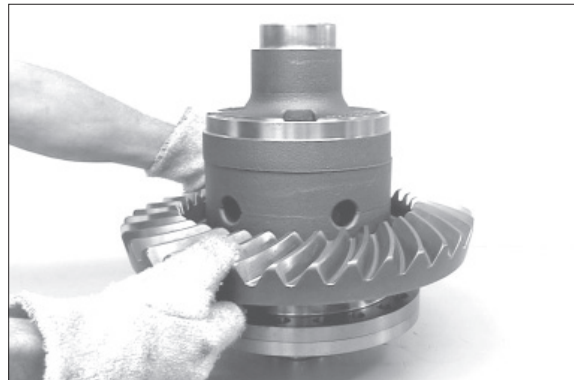

7577AAXF145

- ③⑪ Fix differential by means of press and fasten crown wheel by means of new locking screws.
- Tightening torque : 41.8 kgf · m
(302 lbf · ft)

▲ Only use of new locking screws is permissible.

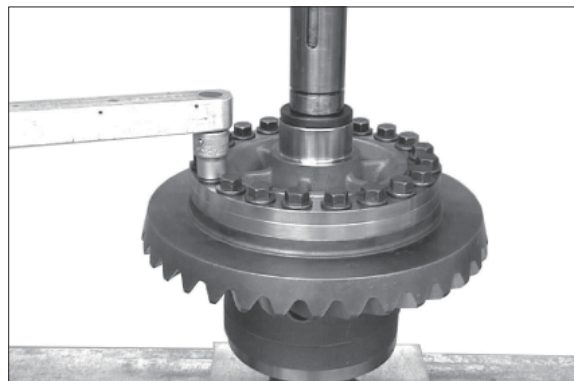

7577AAXF146

- ③⑫ Press on both bearing outer rings until contact.



7577AAXF147

- ③③ Insert differential into the axle drive housing by means of lifting tackle.

※ Special tool

Lifting tackle

5870 281 013

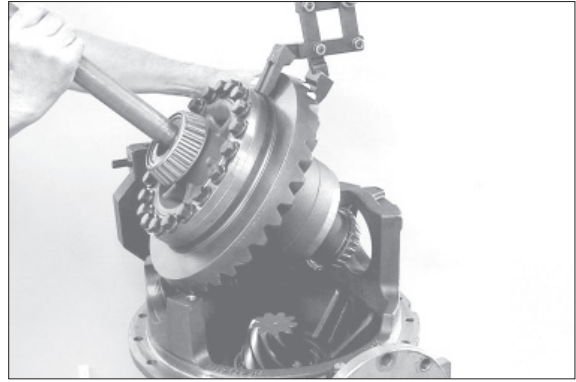

7577AAXF148

- ③④ Place bearing outer ring into the axle drive housing.

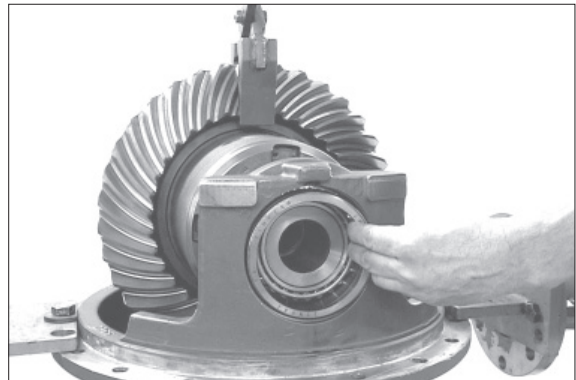

7577AAXF149

- ③⑤ Preliminarily fix the bearing outer ring by means of adjusting nut.

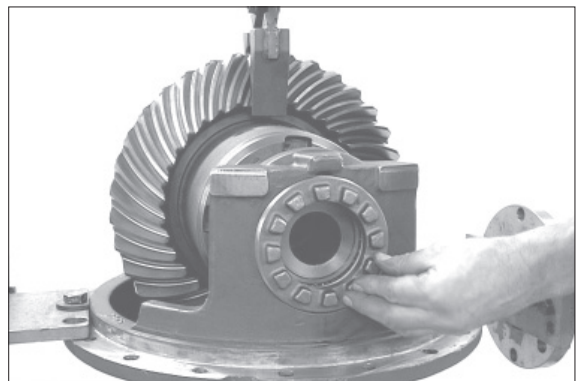

7577AAXF150

- ③⑥ Install crown wheel-sided bearing outer ring.

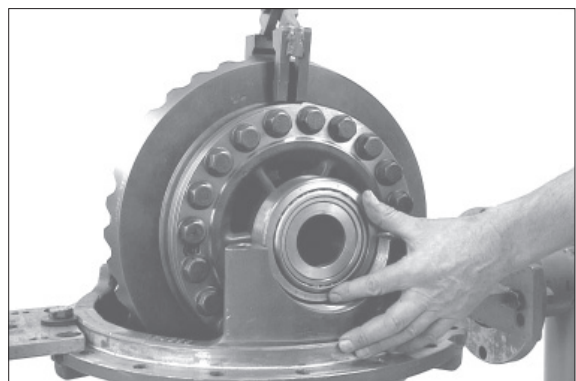

7577AAXF151

- ③⑦ Preliminarily fix the crown wheel-sided bearing outer ring by means of the second adjusting nut.

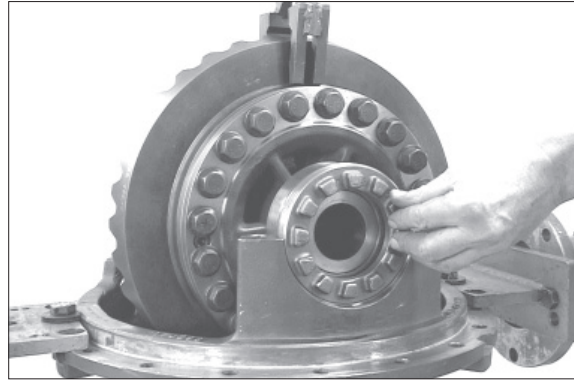

7577AAXF152

- ③⑧ Put on bearing bracket and fasten it by means of hexagon screws and washers.
 - Tightening torque (M16/10.9) :
28.6 kgf · m (207 lbf · ft)

※ Pay attention to clearance of the adjusting nut.

▲ Apply Loctite (type No. 262) onto threads of the hexagon screws.

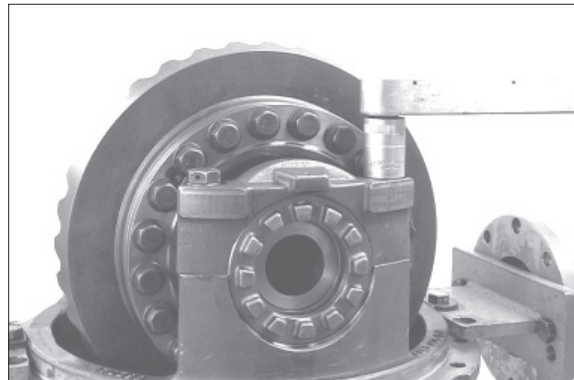

7577AAXF153

Adjustment of backlash and bearing preload

- ③⑨ Place dial indicator right-angled at the outer diameter of the tooth flank (crown wheel).
Then install both adjusting nuts only to such an extent that the required backlash - see the value etched on the outer diameter of the crown wheel - is reached.

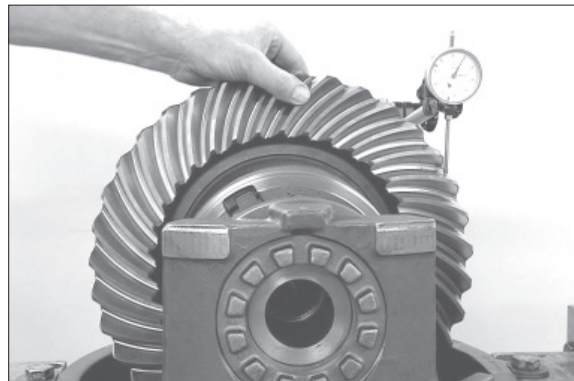

7577AAXF154

- ※ Special tool

Magnetic stand	5870 200 055
Dial indicator	5870 200 057
Socket spanner	5870 656 079

※ At this step rotate the differential several times.

- ④⑩ Determine bracket width and correct it on both adjusting nuts, if required.

Bracket width418^{-0.05} mm

- ※ Special tool

Caliper gauge	5870 200 058
---------------	--------------

Then check backlash once again.

※ Adjusting of the bracket width results in the required bearing preload.

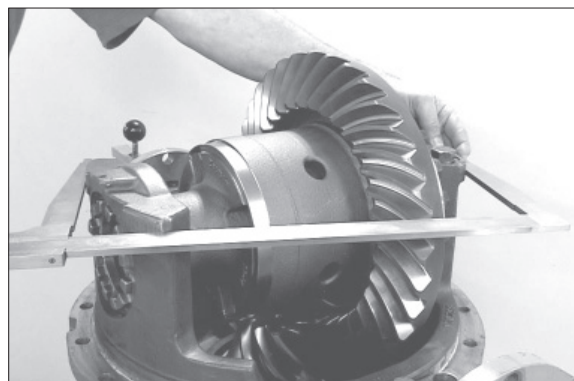

7577AAXF155

- ④① Cover some tooth flanks of the crown wheel with marking ink and roll crown wheel in both directions over the drive pinion.

Compare the obtained tooth contact pattern with the examples on page 3-269.

- ▲ If the tooth contact pattern differs, there has been a measuring error at determination of the shim (figure 7577AAXF121/page 3-273), what is imperative to be corrected.

- ④② Secure both adjusting nuts by means of slotted pins.

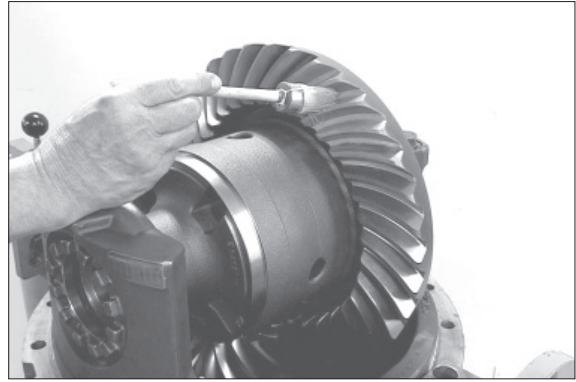

7577AAXF156

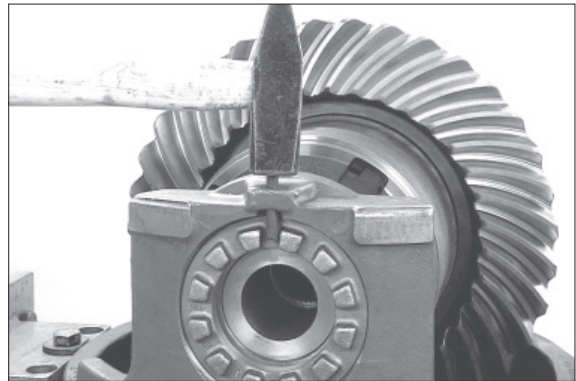

7577AAXF157

- ④③ Install two adjusting screws and insert differential carrier into the axle casing until contact by means of lifting tackle.

※ Special tool

Adjusting screws 5870 204 023

Lifting tackle 5870 281 044

※ Observe radial location (see marking Page 3-249 / Figure 7577AAXF081).

- ▲ Apply sealing compound (Three Bond Type 1215) on mounting face.

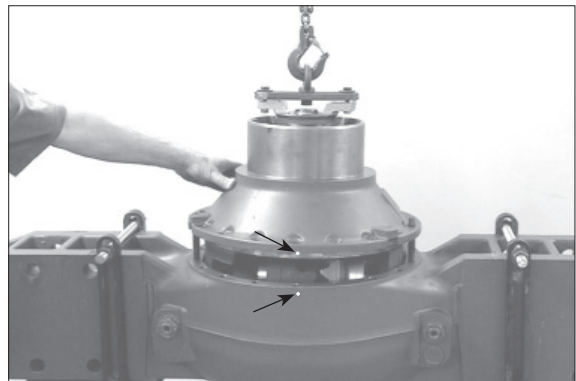

7577AAXF158

- ④④ Fasten differential carrier by means of new locking screws.

· Tightening torque : 25.5 kgf · m
(184 lbf · ft)

- ▲ Only use of the new locking screws is permissible.

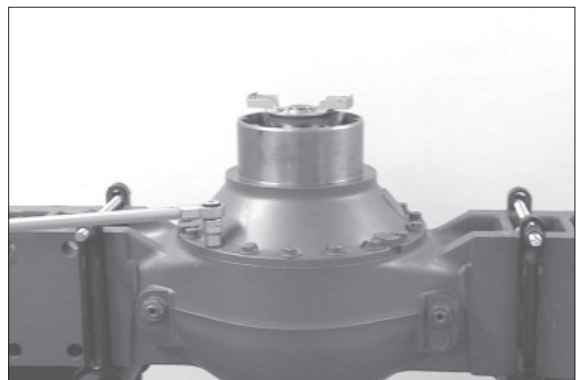

7577AAXF159

- ④⑤ Insert stub shaft into spline of the axle bevel gear until contact.

Then fix O-ring (see arrow) by means of grease into the recess of the axle casing.

- ※ Step (Figure 7577AAXF160 ~ 163) is to be made on both output sides.

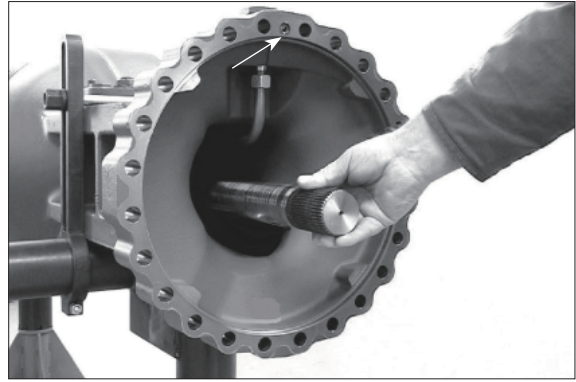

7577AAXF160

- ④⑥ Thrust washer (s) removed at disassembly have to be fixed in the sun gear shaft by means of grease.



7577AAXF161

- ④⑦ Place complete output by means of lifting tackle to the axle casing until contact.

- ※ Special tool
Lifting bracket 5870 281 043

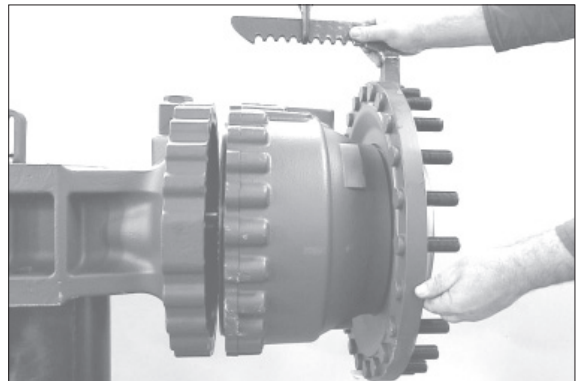

7577AAXF162

- ④⑧ Fasten output by means of hexagon screws and washers.

- Tightening torque (M18/10.9) :
39.8 kgf · m (288 lbf · ft)

- ※ Prior to putting into operation of the axle, fill oil in accordance with lubrication instructions.

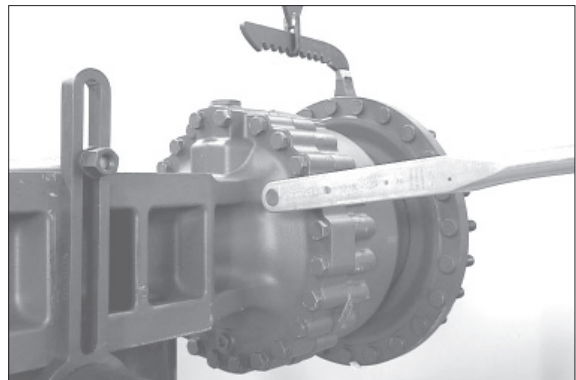

7577AAXF163

※ **BACKLASH CHECK**

- Applied the paint (or red lead) on the surface of several bevel gear teeth.
- Turn the pinioin gear and check the contact pattern.

Correct pattern

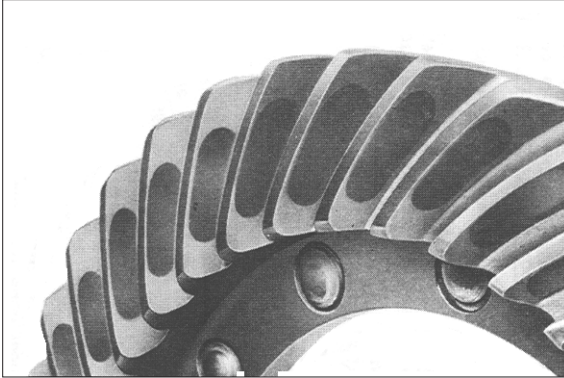

Concave side



Convex side

※ **ADJUSTMENT**

Incorrect pattern : high contact

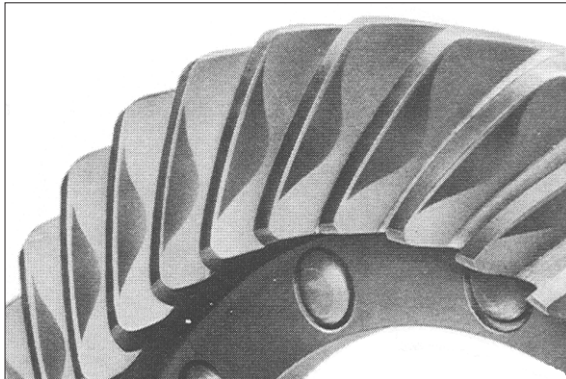

Concave side

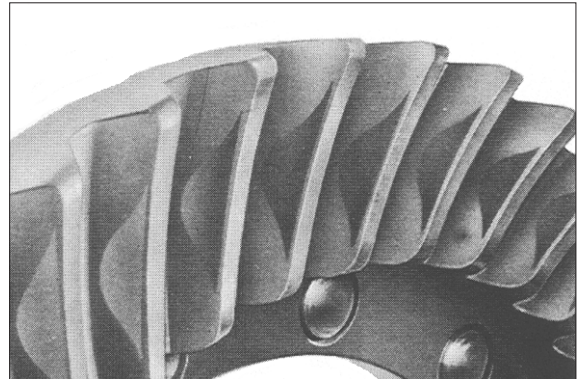

Convex side

- Reduce the distance (-)

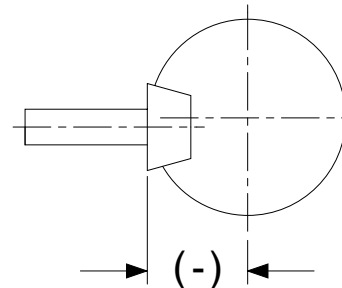

WTHAX20

Incorrect pattern, low contact

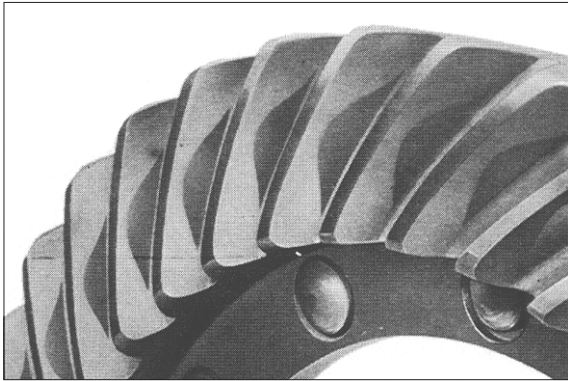

WTHAX21

Concave side

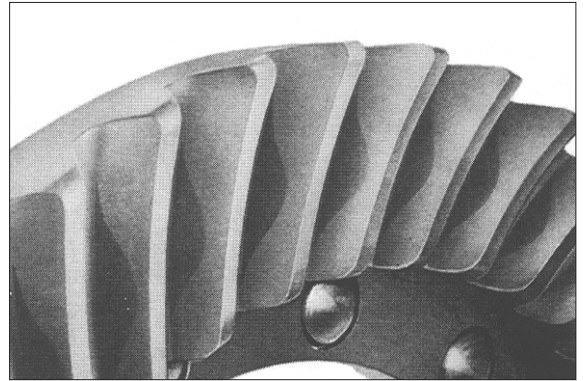

WTHAX22

Convex side

- Add the distance (+)

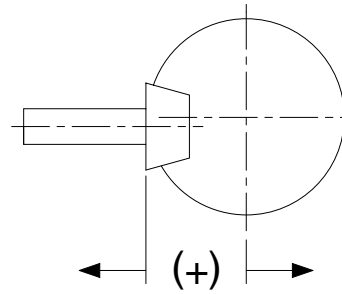

WTHAX23