

## GROUP 4 DISASSEMBLY AND ASSEMBLY

### 1. STEERING UNIT

#### 1) STRUCTURE

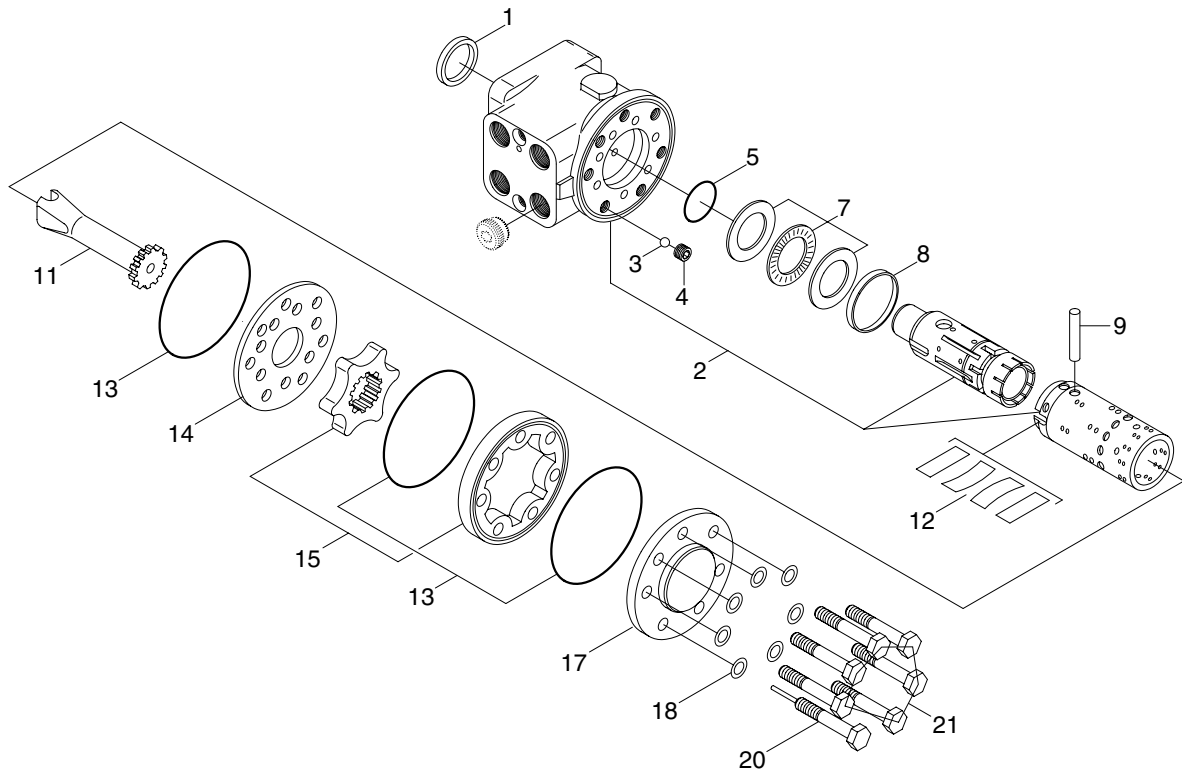

7607SE10

1	Dust seal	8	Ring	15	Gearwheel set
2	Housing, spool, sleeve	9	Cross pin	17	End cover
3	Ball	11	Cardan shaft	18	Washer
4	Thread bushing	12	Set of springs	20	Screw with pin
5	O-ring	13	O-ring	21	Screw
7	Bearing assembly	14	Distributor plate		

## 2) TOOLS

(1) Holding tool + Guide ring

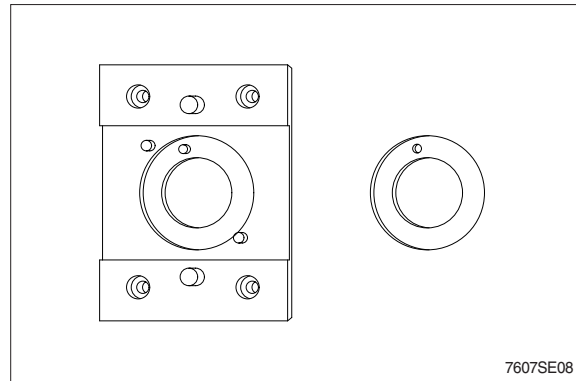

(2) Assembly tool for O-ring and kin-ring.

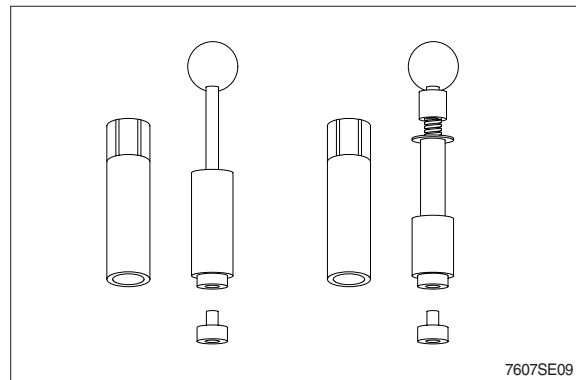

(3) Assembly tool for lip seal.

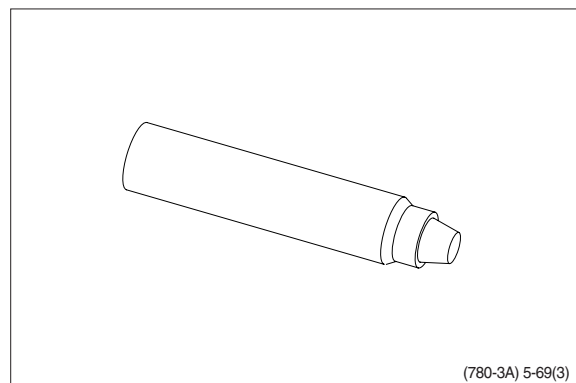

(4) Assembly tool for cardan shaft.

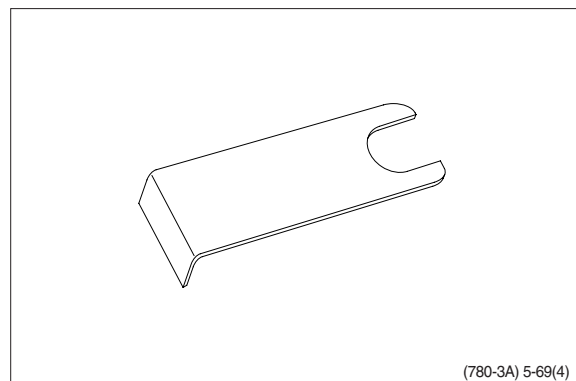

(5) Assembly tool for dust seal.

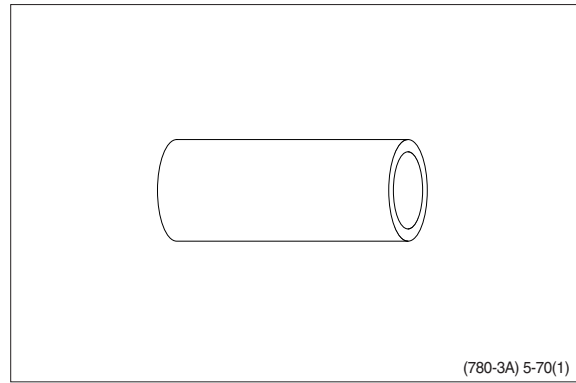

- (6) Torque wrench 0~7.1 kgf · m  
(0~54.4 lbf · ft)
- 13 mm socket spanner
- 6, 8 mm and 12 mm hexagon sockets
- 12 mm screwdriver
- 2 mm screwdriver
- 13 mm ring spanner
- 6, 8 and 12 mm hexagon socket spanners
- Plastic hammer
- Tweezers

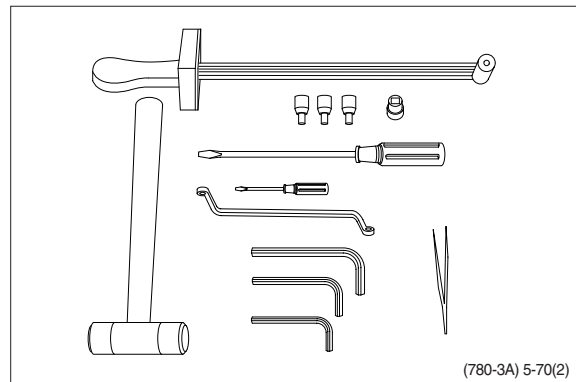

### 3) TIGHTENING TORQUE AND HYDRAULIC CONNECTIONS

#### (1) Hydraulic connections

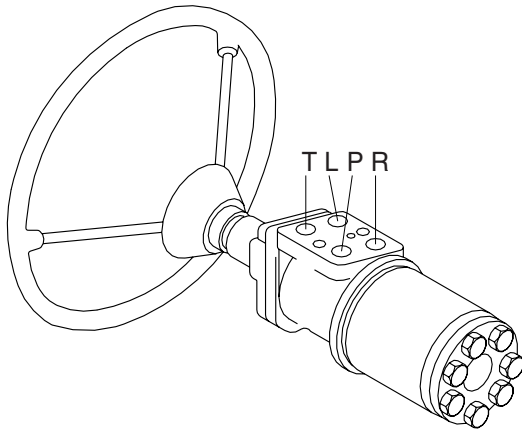

L : Left port  
 R : Right port  
 T : Tank  
 P : Pump

(780-3A) 5-71

#### (2) Tightening torque

Screwed connection	Max. tightening torque [ kgf · m (lb · ft) ]			
	With cutting edge	With copper washer	With aluminum washer	With O - ring
1/4 BSP.F	4.1 (29.7)	2.0 (14.5)	3.1 (22.4)	-
3/8 BSP.F	6.1 (44.1)	2.0 (14.5)	5.1 (36.9)	-
1/2 BSP.F	10.2 (73.8)	3.1 (22.4)	8.2 (59.3)	-
7/16-20 UNF	-	2.0 (14.5)	-	-
3/4-16 UNF	-	6.1 (44.1)	-	-
M 12 × 1.5	4.1 (29.7)	2.0 (14.5)	3.1 (22.4)	2.0 (14.5)
M 18 × 1.5	7.1 (51.4)	2.0 (14.5)	5.1 (36.9)	5.1 (36.9)
M 22 × 1.5	10.2 (73.8)	3.1 (22.4)	8.2 (59.3)	7.1 (51.4)

#### 4) DISASSEMBLY

- (1) Disassemble steering column from steering unit and place the steering unit in the holding tool.  
Screw out the screws in the end cover (6-off plus one special screw).

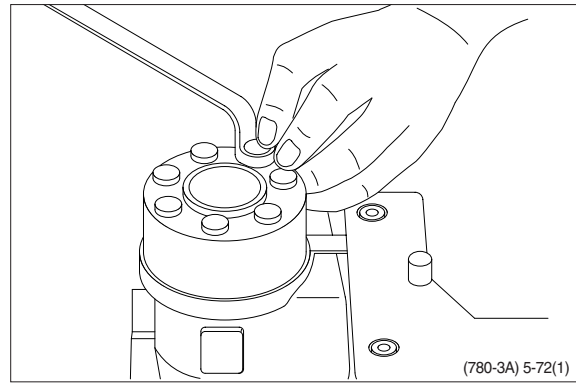

- (2) Remove the end cover, sideways.

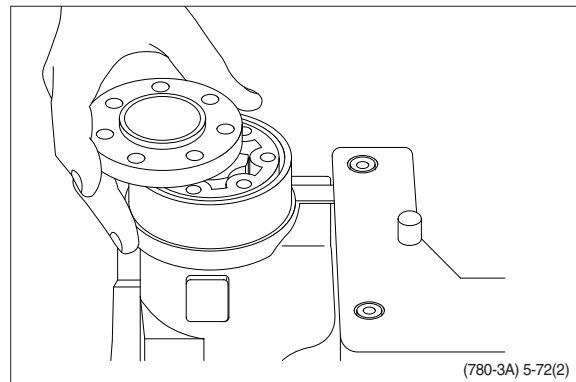

- (3) Lift the gearwheel set (with spacer if fitted) off the unit.  
Take out the two O-rings.

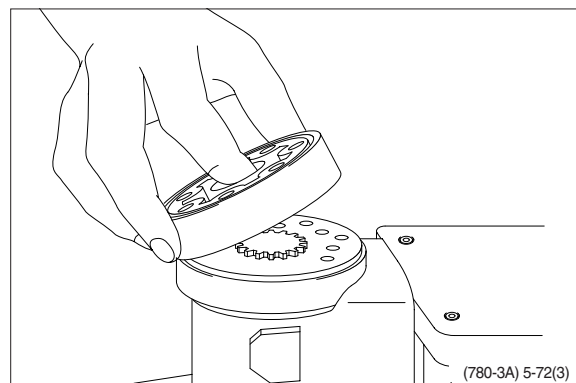

- (4) Remove cardan shaft.

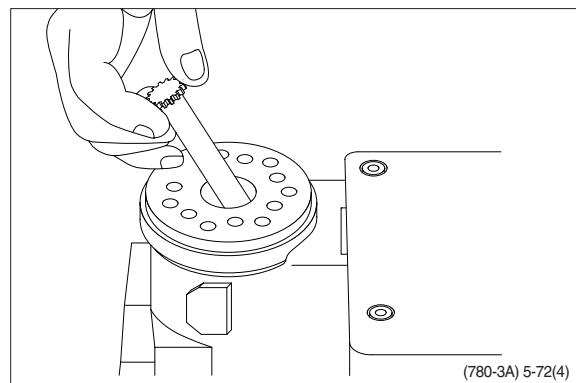

(5) Remove distributor plate.

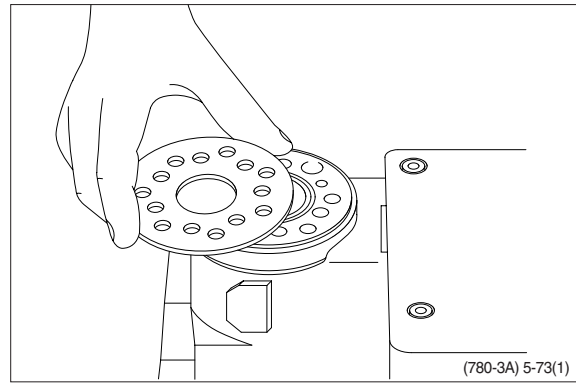

(6) Screw out the threaded bush over the check valve.

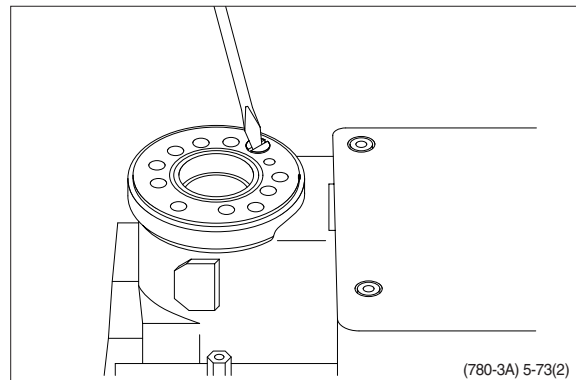

(7) Remove O-ring.

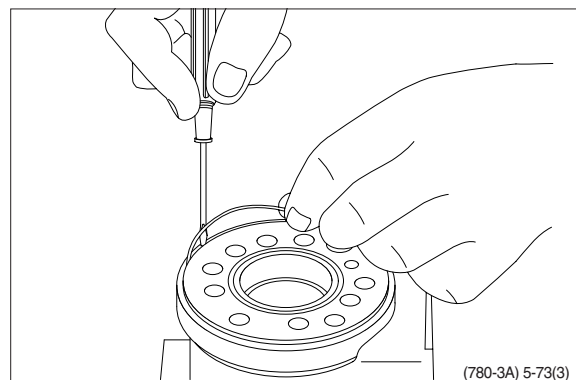

(8) Take care to keep the cross pin in the sleeve and spool horizontal. The pin can be seen through the open end of the spool. Press the spool inwards and the sleeve, ring, bearing races and needle bearing will be pushed out of the housing together.

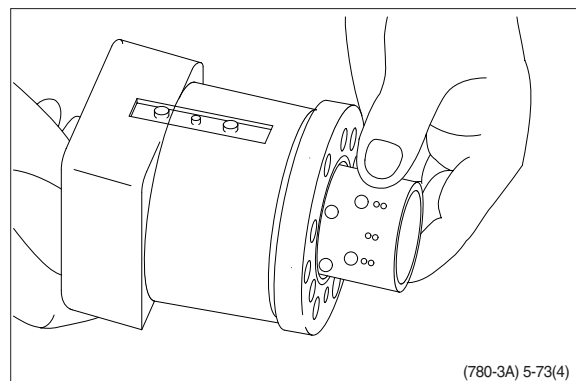

- (9) Take ring, bearing races and needle bearing from sleeve and spool. The outer (thin) bearing race can sometimes "stick" in the housing, therefore check that it has come out.

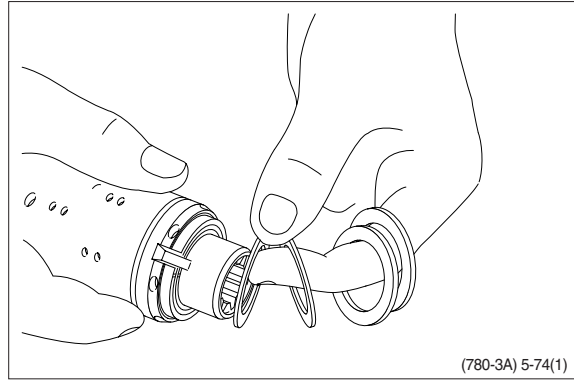

- (10) Press out the cross pin. Use the special screw from the end cover.

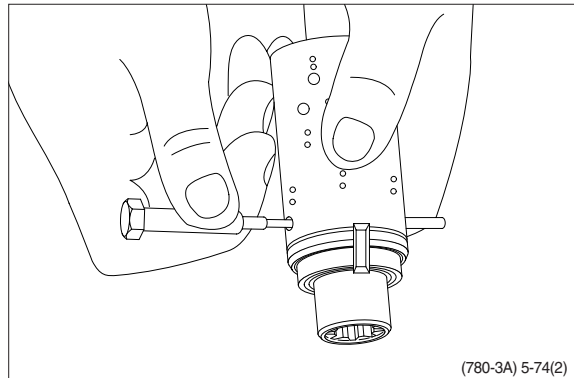

- ※ A small mark has been made with a pumice stone on both spool and sleeve close to one of the slots for the neutral position springs (see drawing). If the mark is not visible, remember to leave a mark of your own on sleeve and spool before the neutral position springs are disassembled.

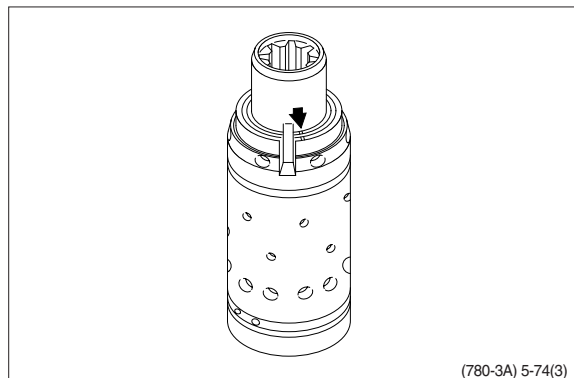

- (11) Carefully press the spool out of the sleeve.

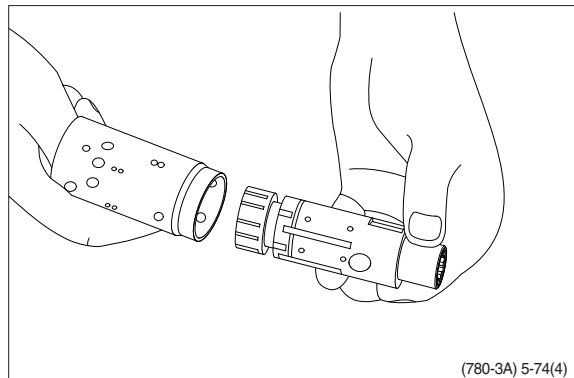

(12) Press the neutral position springs out of their slots in the spool.

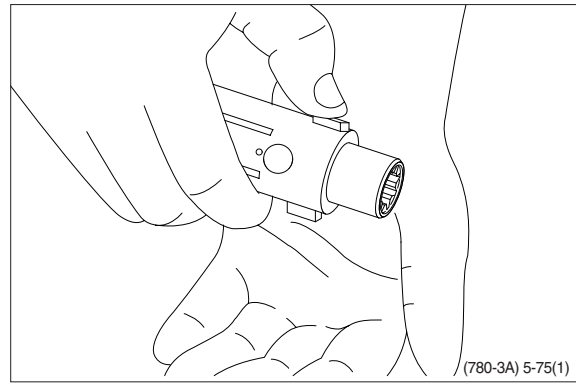

(13) Remove dust seal and O-ring.

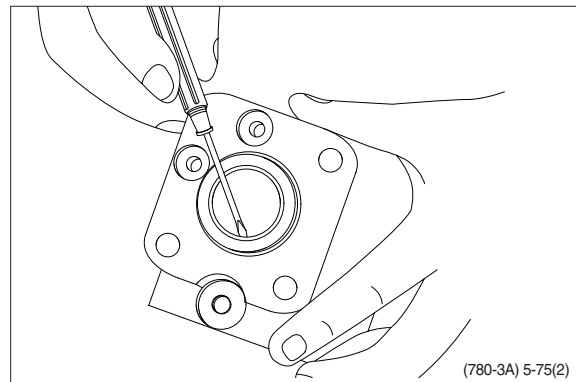

(14) The steering unit is now completely disassembled.

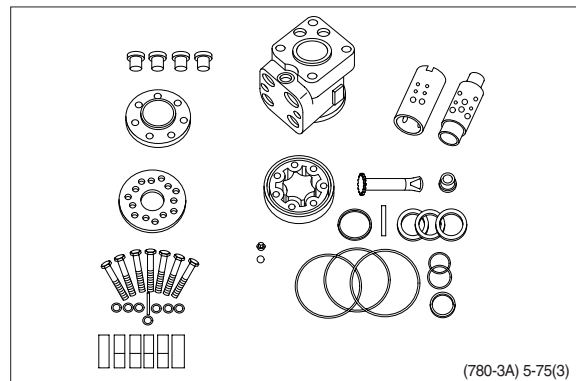

- ※ Cleaning  
Clean all parts carefully in Shellsol K or the like.
- ※ Inspection and replacement  
Replace all seals and washers. Check all parts carefully and make any replacements necessary.
- ※ Lubrication  
Before assembly, lubricate all parts with hydraulic oil.

- (1) Place the two flat neutral position springs in the slot.  
Place the curved springs between the flat ones and press them into place.

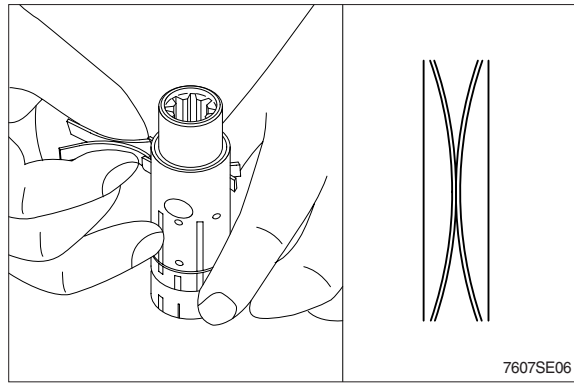

- (2) Line up the spring set.

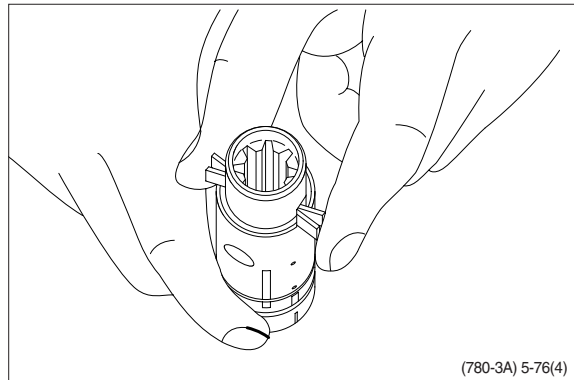

- (3) Assemble the spool/sleeve and make sure the marks on spool and sleeve are opposite each other (see drawing page 5-36).

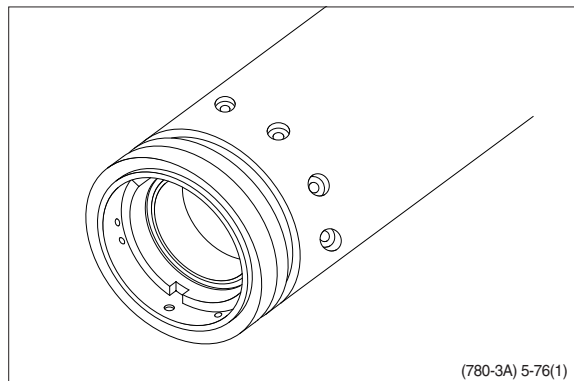

- (4) Press the springs together and push the neutral position springs into place in the sleeve.

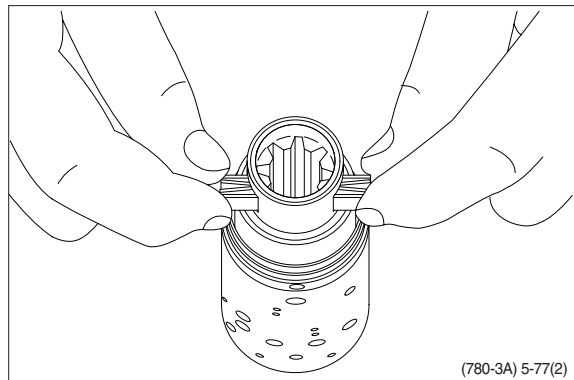

(5) Line up the springs and center them.

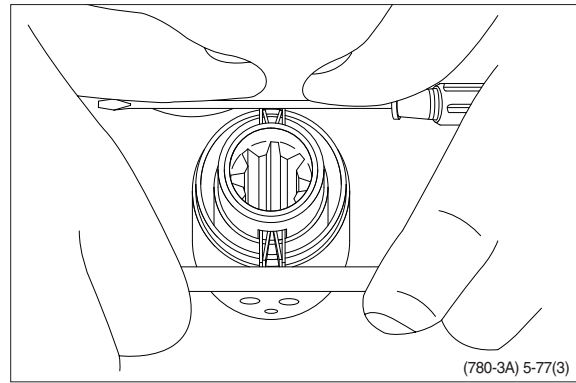

(6) Guide the ring down over the sleeve.

※ The ring should be able to move-free of the springs.

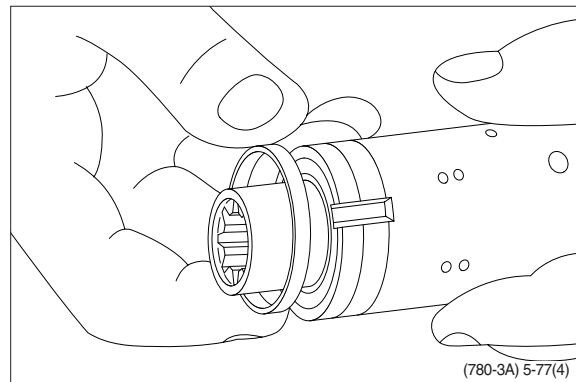

(7) Fit the cross pin into the spool / sleeve.

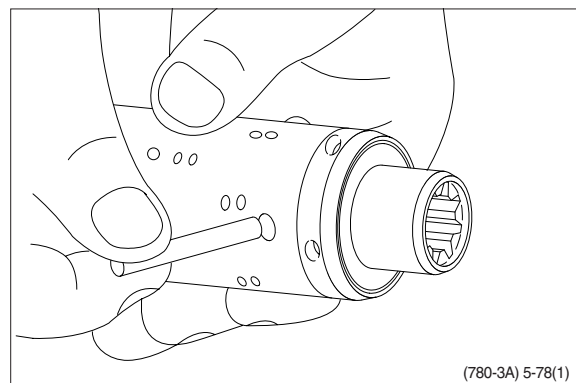

(8) Fit bearing races and needle bearing.  
(See the next page)

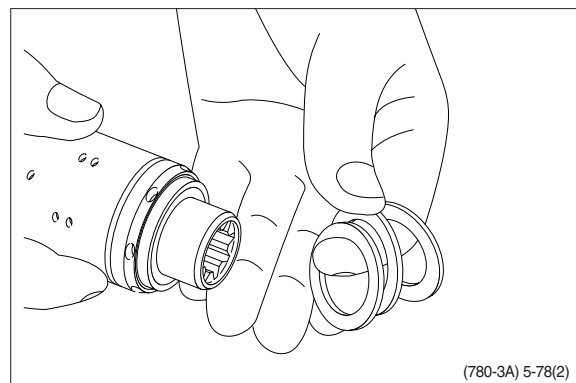

※ Assembly pattern for standard bearings

- 1 Outer bearing race
- 2 Needle bearing
- 3 Inner bearing race
- 4 Spool
- 5 Sleeve

\* The inside chamfer on the inner bearing race must face the inner spool.

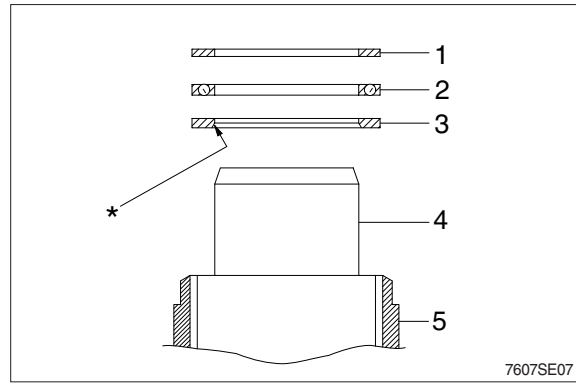

Installation instruction for O-ring

(9) Turn the steering unit until the bore is horizontal. Guide the outer part of the assembly tool into the bore for the spool / sleeve.

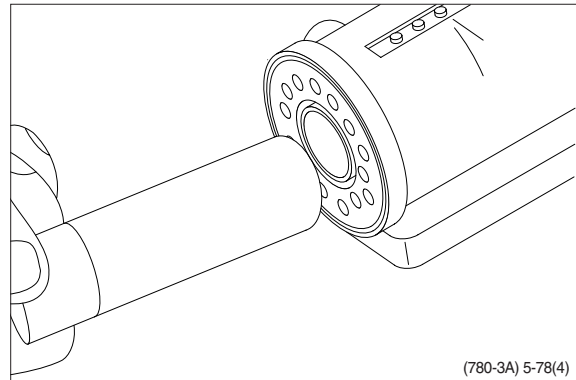

(10) Grease O-ring with hydraulic oil and place them on the tool.

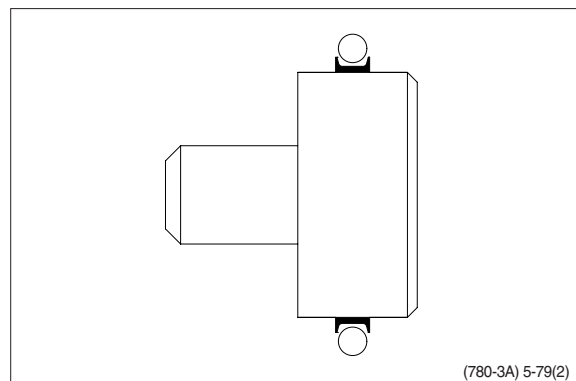
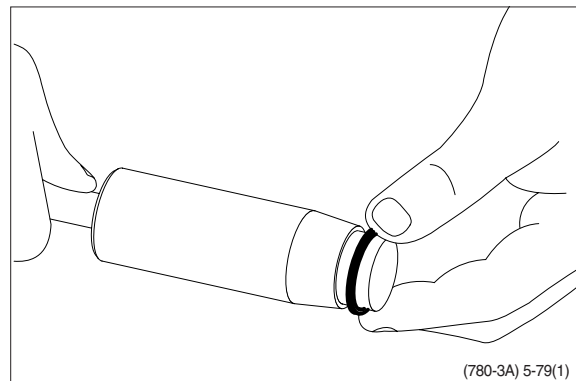

- (11) Hold the outer part of the assembly tool in the bottom of the steering unit housing and guide the inner part of the tool right to the bottom.

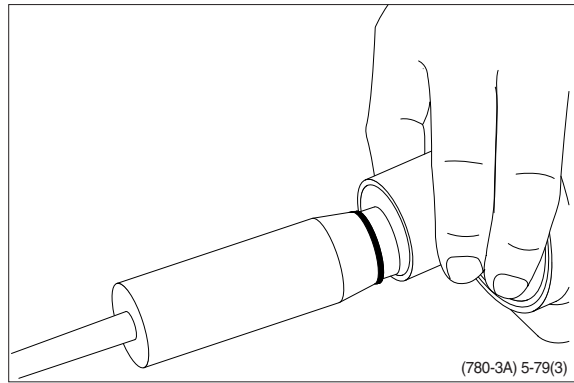

- (12) Press and turn the O-ring into position in the housing.

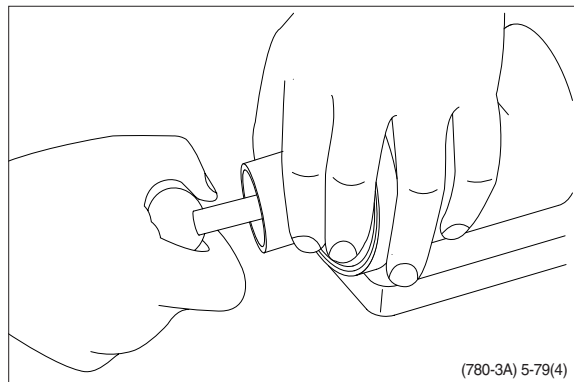

- (13) Draw the inner and outer parts of the assembly tool out of the steering unit bore, leaving the guide from the inner part in the bore.

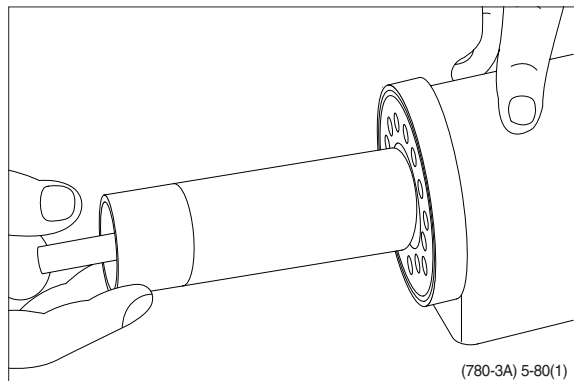

#### **Installation instructions for lip seal**

- (14) Lubricate the lip seal with hydraulic oil and place it on the assembly tool.

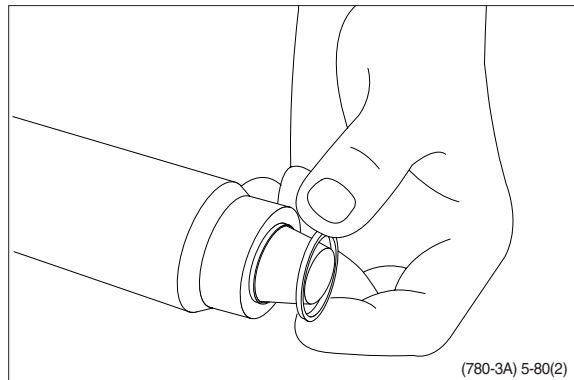

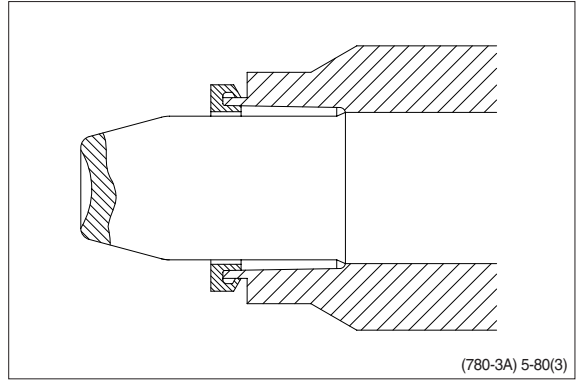

(15) Guide the assembly tool right to the bottom.

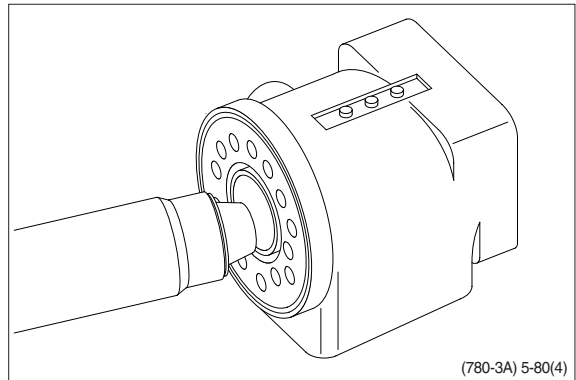

(16) Press and turn the lip seal into place in the housing.

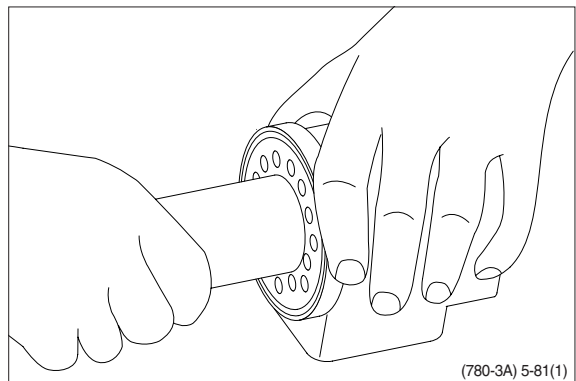

(17) With a light turning movement, guide the spool and sleeve into the bore.

※ Fit the spool set holding the cross pin horizontal.

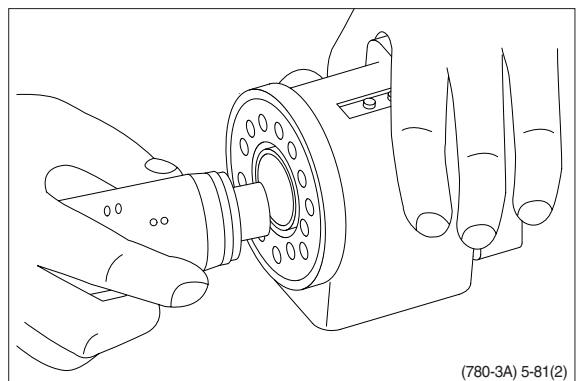

(18) The spool set will push out the assembly tool guide. The O-ring are now in position.

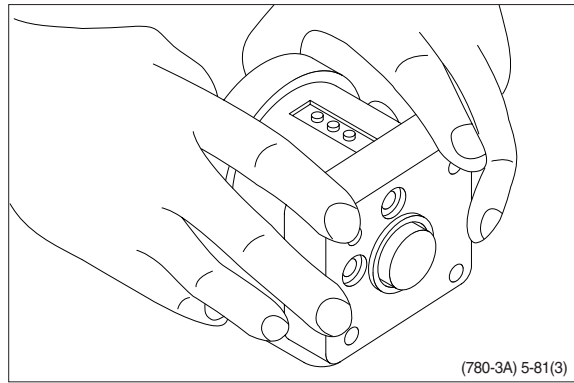

(19) Turn the steering unit until the bore is vertical again. Put the check valve ball into the hole indicated by the arrow.

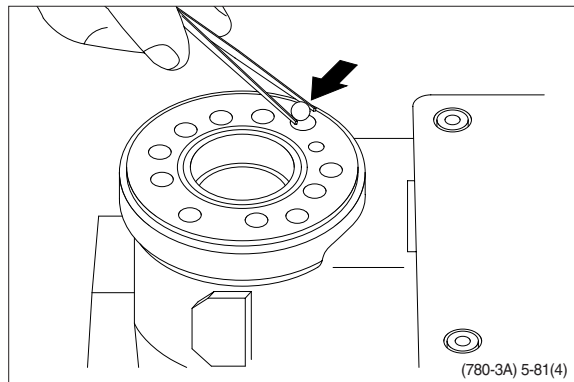

(20) Screw the threaded bush lightly into the check valve bore. The top of the bush must lie just below the surface of the housing.

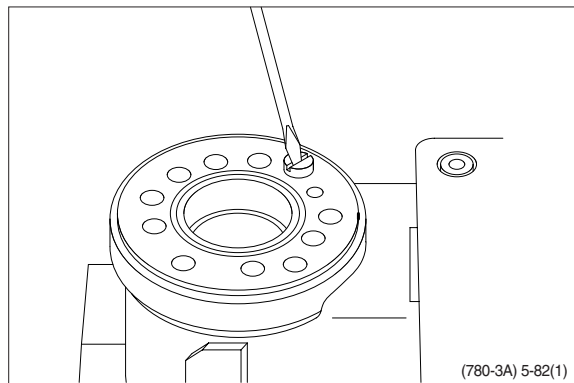

(21) Grease the O-ring with mineral oil approx. viscosity 500 cSt at 20°C.

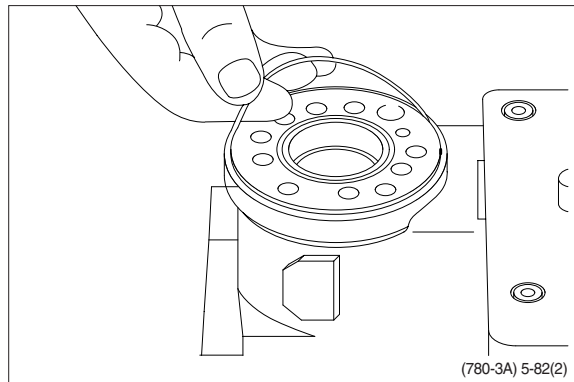

(22) Place the distributor plate so that the channel holes match the holes in the housing.

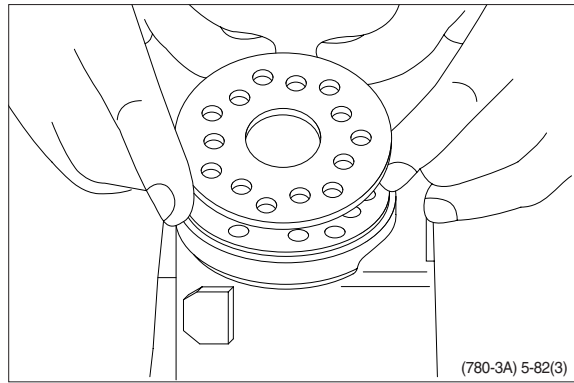

(23) Guide the cardan shaft down into the bore so that the slot is parallel with the connection flange.

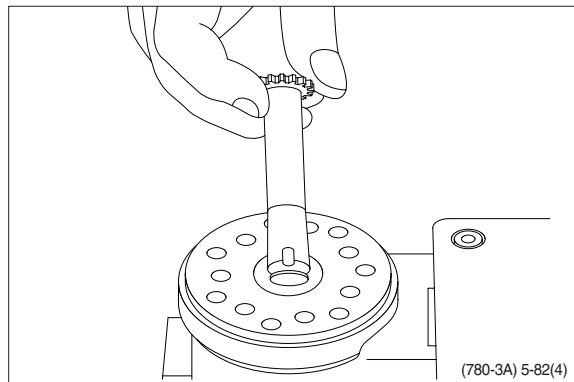

(24) Place the cardan shaft as shown - so that it is held in position by the mounting fork.

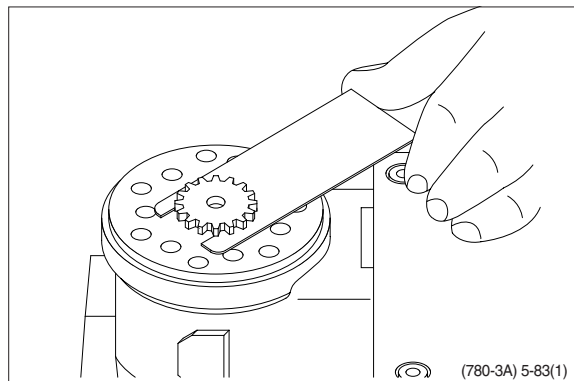

(25) Grease the two O-rings with mineral oil approx. viscosity 500 cSt at 20°C and place them in the two grooves in the gear rim. Fit the gearwheel and rim on the cardan shaft.

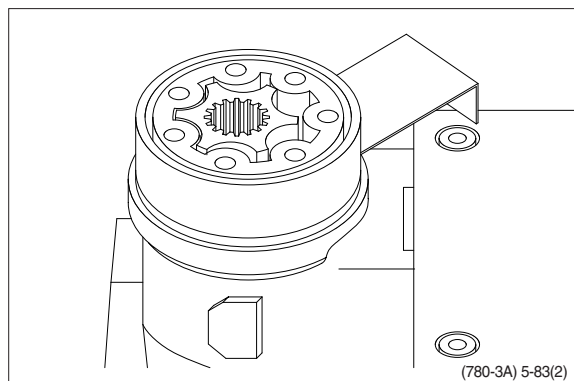

**(26) Important**

Fit the gearwheel (rotor) and cardan shaft so that a tooth base in the rotor is positioned in relation to the shaft slot as shown.

Turn the gear rim so that the seven through holes match the holes in the housing.

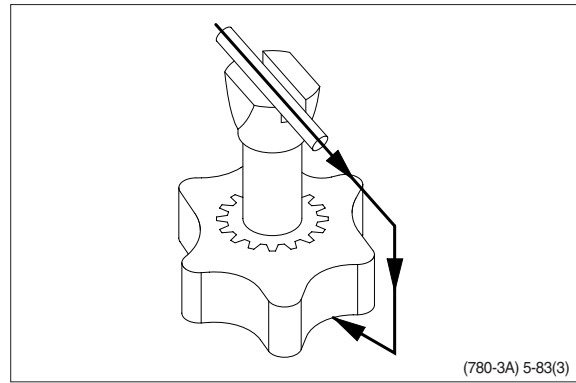

**(27) Fit the spacer, if any.**

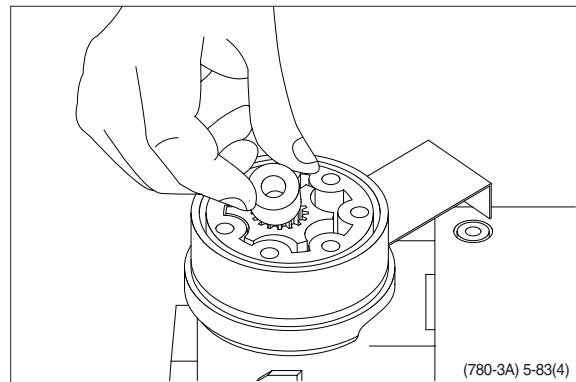

**(28) Place the end cover in position.**

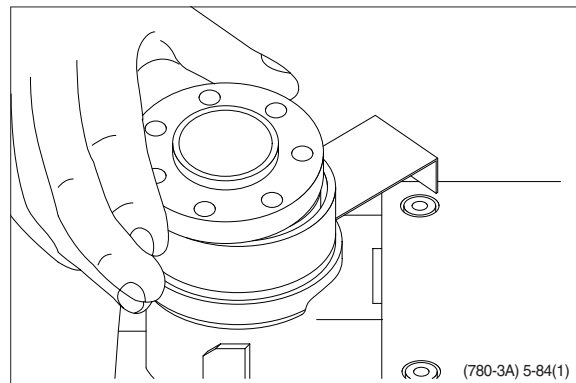

**(29) Fit the special screw with washer and place it in the hole shown.**

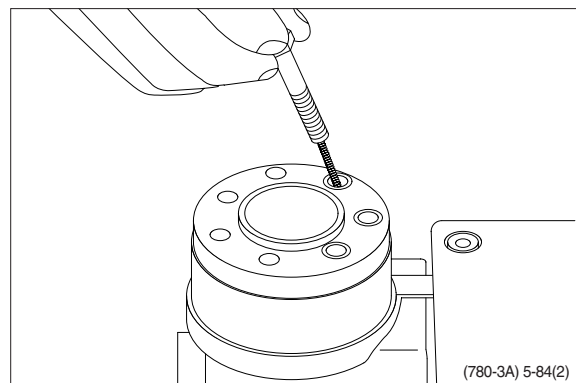

(30) Fit the six screws with washers and insert them. Cross-tighten all the screws and the rolled pin.

- Tightening torque :  $3.1 \pm 0.6 \text{ kgf} \cdot \text{m}$   
( $22.4 \pm 4.3 \text{ lbf} \cdot \text{ft}$ )

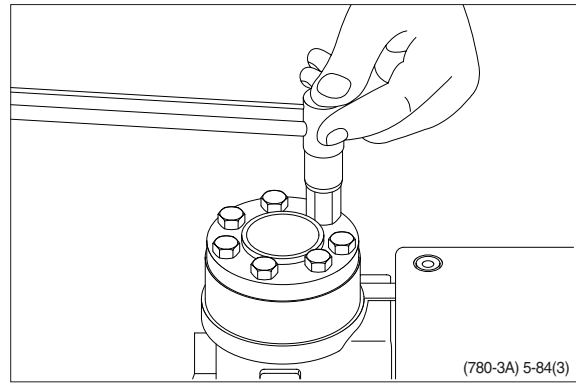

(31) Place the dust seal ring in the housing.

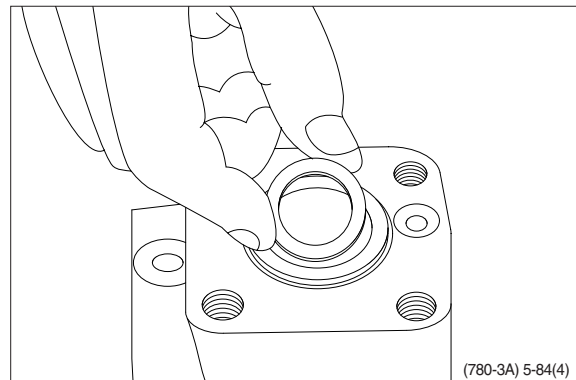

(32) Fit the dust seal ring in the housing using special tool and a plastic hammer.

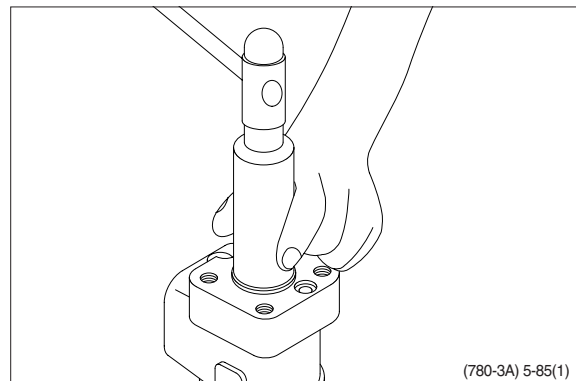

(33) Press the plastic plugs into the connection ports.

- ※ Do not use a hammer!

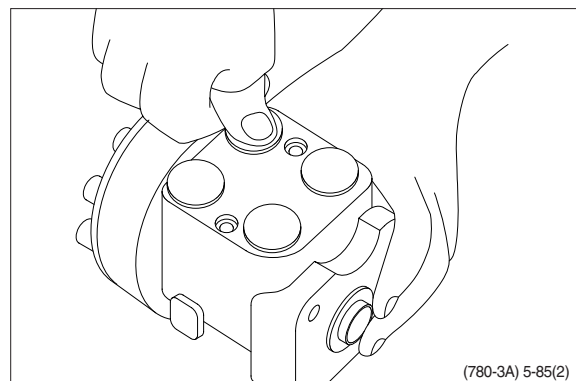

## 2. STEERING CYLINDER

### 1) STRUCTURE

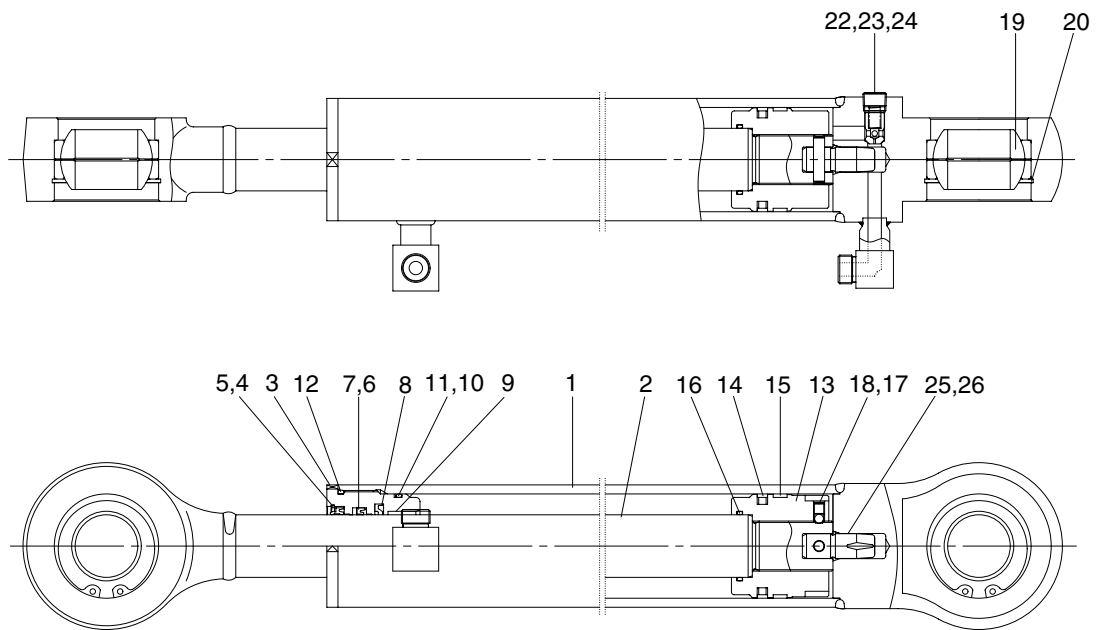

76095SE05

1	Tube assembly	10	O-ring	19	Spherical bearing
2	Rod assembly	11	Back up ring	20	Retaining ring
3	Gland	12	O-ring	21	O-ring
4	Dust wiper	13	Piston	22	Hexagon socket plug
5	Retaining ring	14	Piston seal	23	Check valve
6	Rod seal	15	Wear ring	24	Spring
7	Back up ring	16	O-ring	25	Cushion plunger
8	Buffer ring	17	Steel ball	26	Pin
9	Du bushing	18	Set screw		

## 2) TOOLS AND TIGHTENING TORQUE

### (1) Tools

Tool name	Remark
Wrench	For gland
(-) Driver	Small and large sizes
Torque wrench	Capable of tightening with the specified torques

### (2) Tightening torque

Part name	Item	Size	Torque	
			kgf · m	lbf · ft
Gland	3	M80×2	64±6.4	463±46.3
Piston	13	M36×2	90±9	650±65.1
Set screw	18	M 8×1.25	2±0.2	14.5±1.4

### 3) DISASSEMBLY

#### (1) Remove cylinder head and piston rod

- ① Hold the clevis section of the tube in a vise.
- ※ Use mouth pieces so as not to damage the machined surface of the cylinder tube. Do not make use of the outside piping as a locking means.

- ② Pull out piston rod (2) about 200 mm (7.8 in). Because the piston rod is rather heavy, finish extending it with air pressure after the oil draining operation.

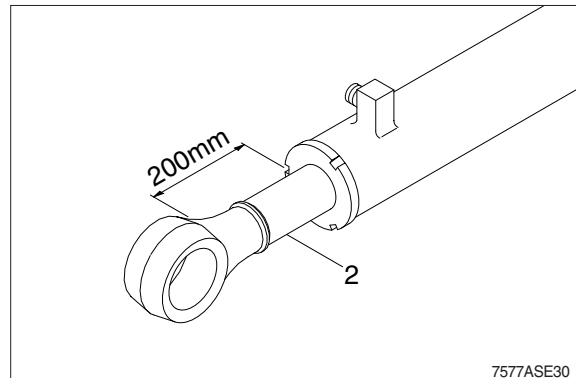

- ③ Loosen and remove the gland (3).

- ※ Cover the extracted piston rod (2) with rag to prevent it from being accidentally damaged during operation.

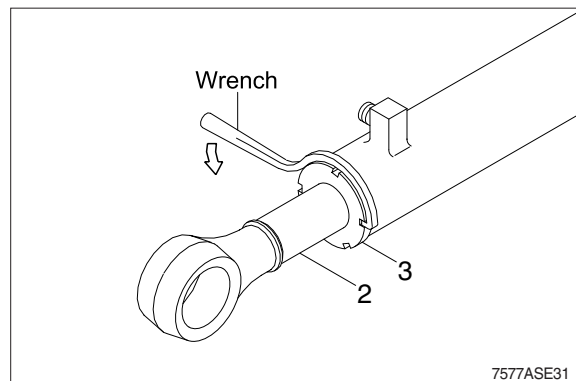

- ④ Draw out gland (3) and piston rod (2) assembly together from cylinder tube (1).

- ※ Since the piston rod assembly is heavy in this case, lift the tip of the piston rod (2) with a crane or some means and draw it out. However, when piston rod (2) has been drawn out to approximately two thirds of its length, lift it in its center to draw it completely.

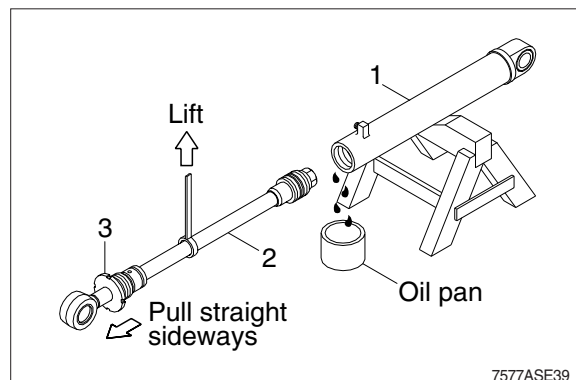

※ Note that the plated surface of piston rod (2) is to be lifted. For this reason, do not use a wire sling and others that may damage it, but use a strong cloth belt or a rope.

- ⑤ Place the removed piston rod assembly on a wooden V-block that is set level.
- ※ Cover a V-block with soft rag.

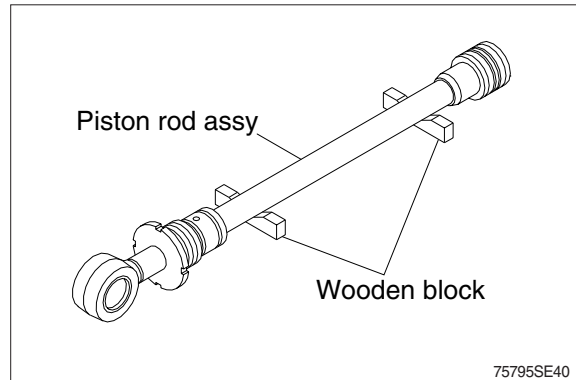

**(2) Remove piston and gland assembly**

- ① Remove the set screw (18) and steel ball (17).
- ② Remove piston assembly (13) and O-ring (16).

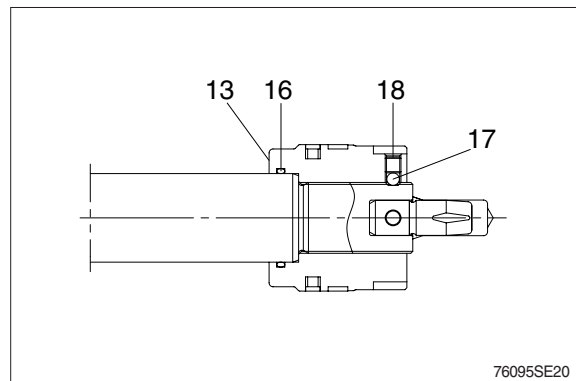

- ③ Remove the gland (3) assembly from piston rod (2).
  - ※ If it is too heavy to move, move it by striking the flanged part of gland (3) with a plastic hammer.
  - ※ Pull it straight with gland assembly lifted with a crane.
- Exercise care so as not to damage the lip of rod bushing (9) and packing (4, 5, 6, 7, 8) by the threads of piston rod (2).

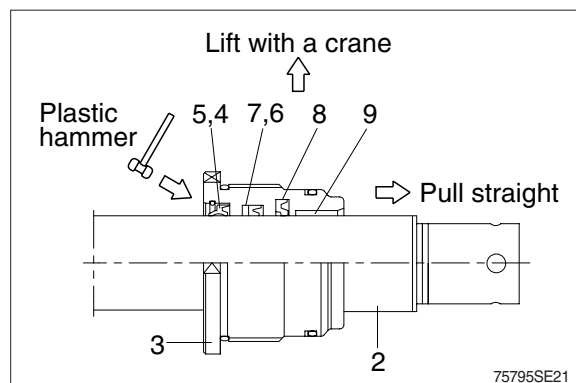

### (3) Disassemble the piston assembly

- ① Remove wear ring (15) and piston seal (14).

Remove O-ring (16).

- ※ Exercise care in this operation not to damage the grooves.

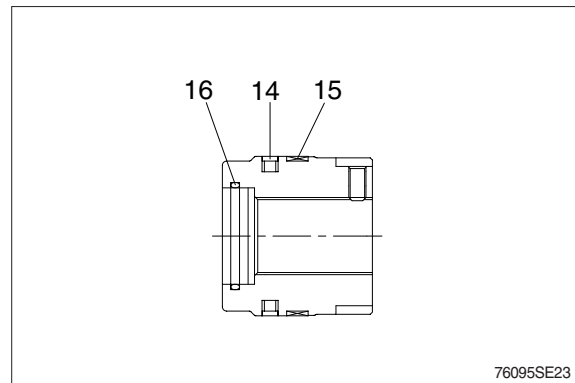

### (4) Disassemble gland assembly

- ① Remove back up ring (11), and O-ring (10).

- ② Remove O-ring (12).

- ③ Remove snap ring (5) and dust wiper (4).

- ④ Remove back up ring (7), rod seal (6) and buffer ring (8).

- ※ Exercise care in this operation not to damage the grooves.

- ※ Do not remove seal and ring, if does not damaged.

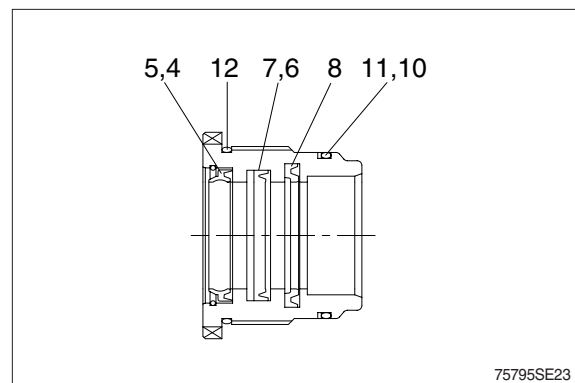

#### 4) ASSEMBLY

##### (1) Assemble gland assembly

※ Check for scratches or rough surfaces if found smooth with an oil stone.

- ① Coat the inner face of gland (3) with hydraulic oil.

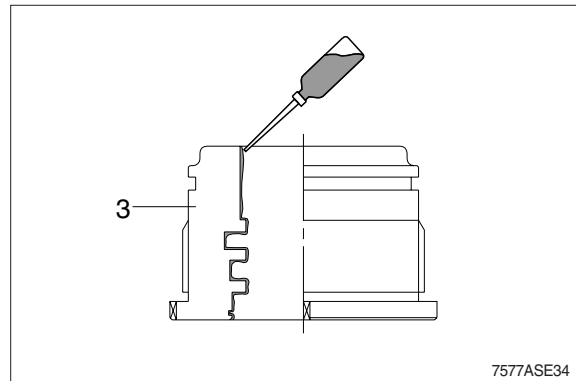

- ② Coat dust wiper (4) with grease and fit dust wiper (4) to the bottom of the hole of dust wiper.

At this time, press a pad metal to the metal ring of dust seal.

- ③ Fit snap ring (5) to the stop face.

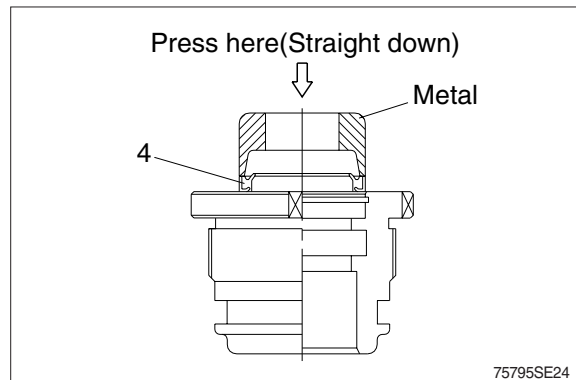

- ④ Fit back up ring (7) and rod seal (6), and buffer ring (8) to corresponding grooves, in that order.

※ Coat each packing with hydraulic oil before fitting it.

※ Insert the backup ring until outside of it is inserted into groove.

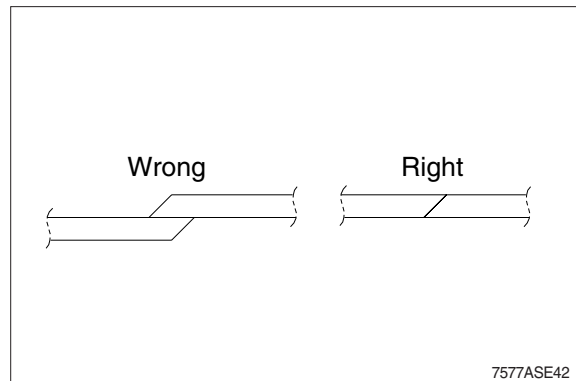

※ Rod seal (6) has its own fitting direction. Therefore, confirm it before fitting them.

※ Fitting rod seal (6) up side down may damage its lip. Therefore check the correct direction that is shown in figure.

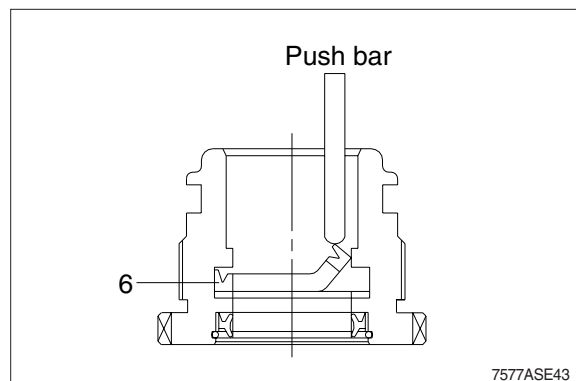

- ⑤ Fit back up ring (11) to gland (3).
- ※ Put the back up ring in the warm water of 30~50°C.
- ⑥ Fit O-ring (10, 12) to gland (3).
- ⑦ Fit bushing (9) to gland (3).

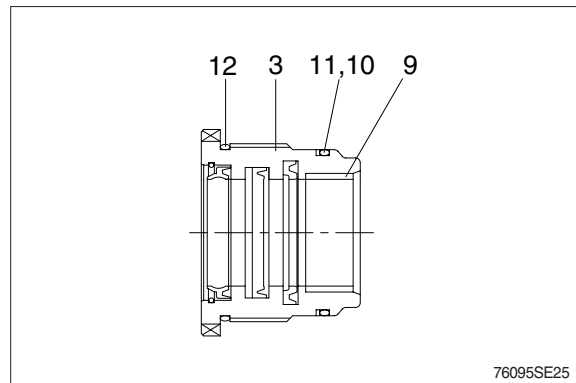

**(2) Assemble piston assembly**

- ※ Check for scratches or rough surfaces.
- ① If found smooth with an oil stone.
- Coat the outer face of piston (13) with hydraulic oil.

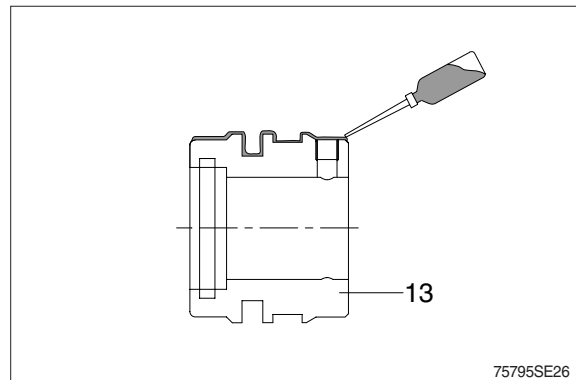

- ② Fit piston seal (14) to piston.
- ※ Put the piston seal in the warm water of 60~100°C for more than 5 minutes.
- ※ After assembling the piston seal, press its outer diameter to fit in.

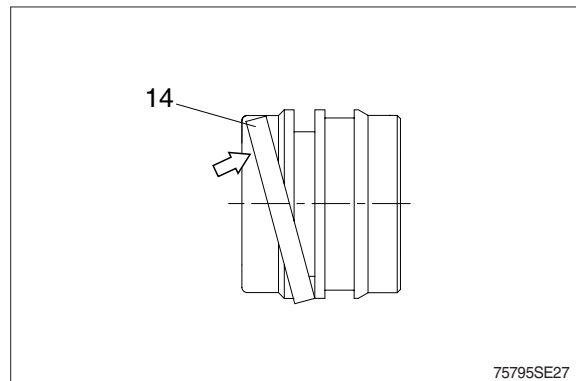

- ③ Fit wear ring (15) to piston (13).
- ④ Fit O-ring (16) to piston (13).

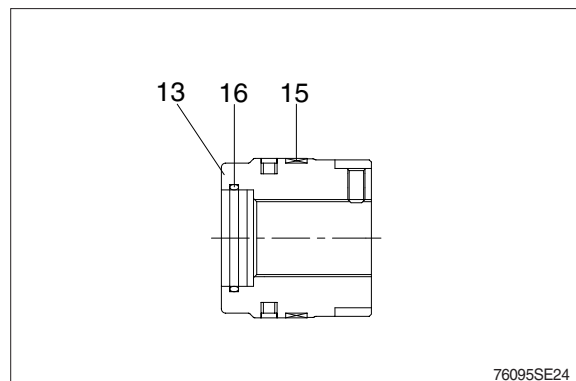

### (3) Install piston and gland assembly

- ① Fix the piston rod assembly to the work bench.
- ② Apply hydraulic oil to the outer surface of piston rod (2), the inner surface of piston and gland (3).
- ③ Insert gland assembly to piston rod (2).

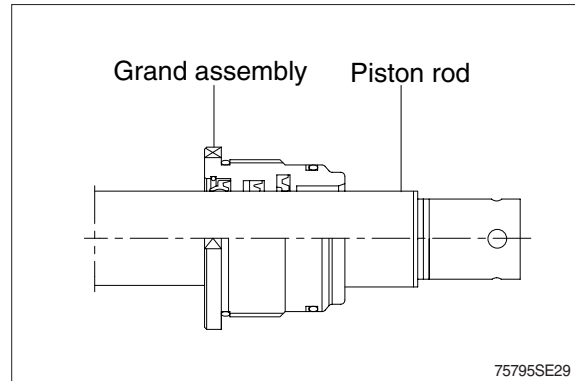

- ④ Fit piston assembly to piston rod.
  - Tightening torque :  $90 \pm 9$  kgf · m  
( $651 \pm 65$  lbf · ft)
- ⑤ Insert the steel ball (17) and the set screw (18).

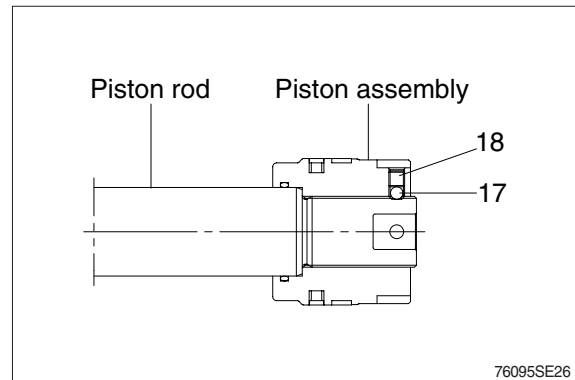

### (4) Overall assembly

- ① Place a V-block on a rigid work bench. Mount the cylinder tube assembly on it and fix the assembly by passing a bar through the clevis pin hole to lock the assembly.
- ② Insert the piston rod assembly in to the cylinder tube assembly, while lifting and moving the piston rod assembly with a crane.
  - ※ Be careful not to damage piston seal by thread of cylinder tube.
- ③ Fit gland to the tube.
  - Tightening torque :  $64 \pm 6.4$  kgf · m  
( $463 \pm 46.3$  lbf · ft)

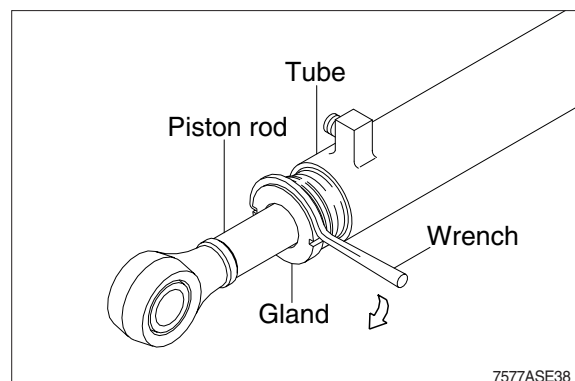
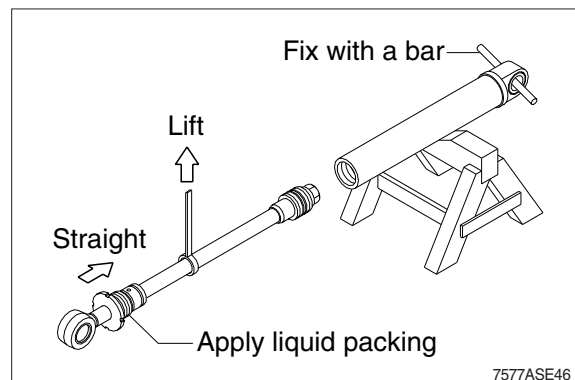

### 3. CENTER PIVOT PIN

#### 1) CONSTRUCTION

Figure shows the construction of the center pivot pin assembly. This assembly serves to connect the front frame with the rear frame; two sets of assemblies are provided, one each for the upper and lower parts. The numbers in parentheses following the parts name denote the item numbers shown in the figure in the disassembly and assembly procedures.

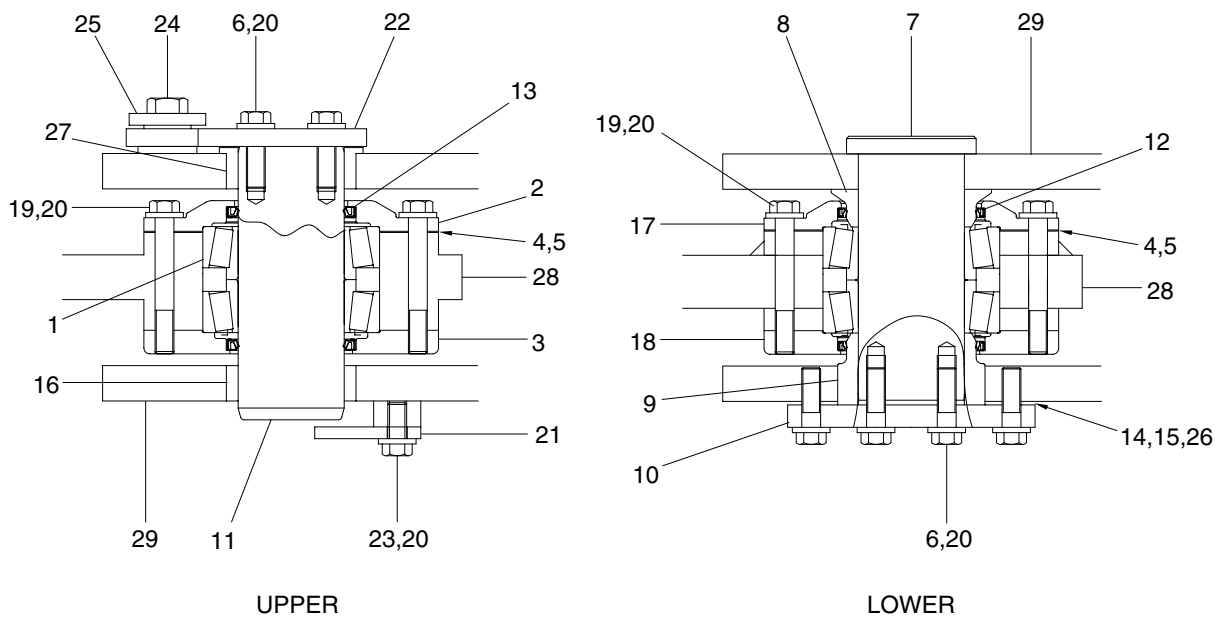

76095SE13

1	Bearing	11	Pin	21	Plate
2	Cover	12	Seal	22	Plate
3	Cover	13	Seal	23	Hexagon bolt
4	Shim (0.1 t)	14	Shim (0.1 t)	24	Hexagon bolt
5	Shim (0.5 t)	15	Shim (0.5 t)	25	Hardened washer
6	Hexagon bolt	16	Bushing	26	Shim (2.0 t)
7	Pin	17	Cover	27	Bushing
8	Collar	18	Cover	28	Front frame
9	Collar	19	Hexagon bolt	29	Rear frame
10	Plate	20	Hardened washer		

## 2) DISASSEMBLY

After supporting the front frame and the rear frame as horizontally as possible using wood blocks and jacks, disassemble as follows: In order to facilitate the disassembly/assembly of the center pivot pins, remove the drive shaft, hydraulic line and steering cylinder first.

- (1) Maintain the horizontal level of front frame (28) and rear frame (29), and then remove hexagon bolt (6, 23, 24), washer (20, 25) and plate (21,22).
- (2) Take out upper pin (11) to the downside using a metal punch.

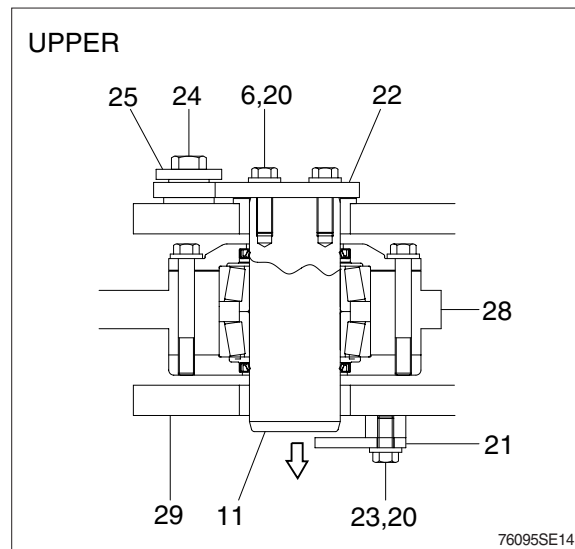

- (3) Maintain the front frame horizontal level, remove hexagon bolts (6) and then remove the plate (10) and shims (14, 15, 26).
- (4) Take out lower pin (7) to the upside using a metal punch carefully.
- (5) Jack up or lifting the front frame (28) slightly, the collar (9) protrudes over the rear frame. Remove the collar (9).
- (6) Lift the frame by passing the slinging wire rope at four positions of front frame, in order to separate it from the rear frame.
- (7) Support the front frame safely.

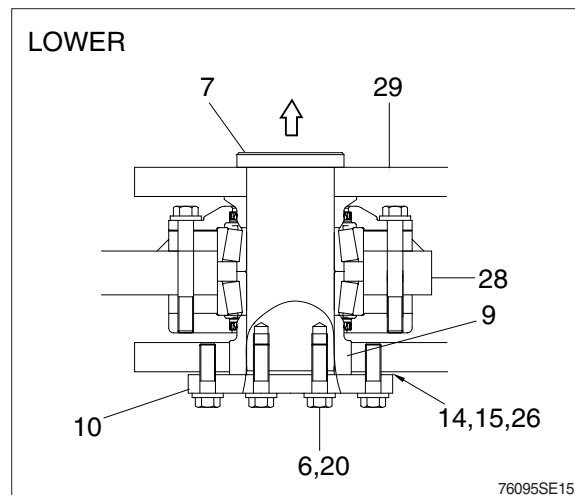

- (8) Remove bolt (19), washer (20) and then take out cover (2) and shims (4, 5).
- (9) Take out dust seal (13) from the cover (2).
- (10) Remove the bearing (1), and dust seal (13).

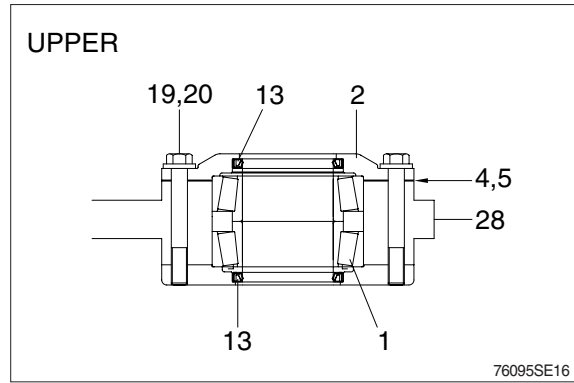

- (11) Remove bolt (19), washer (20) and then take out cover (17, 18) and shims (4, 5).
- (12) Take out the dust seal (12) from the cover (17, 18).
- (13) Remove the bearing (1) and collar (8).

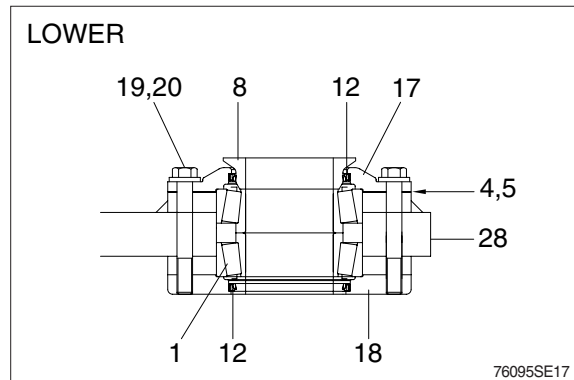

### 3) INSPECTION

- (1) Check the bearing sliding surface for excessive wear, scorching or scratches; replace if necessary.
- (2) Replace all dust seals (12,13) with new ones.
- (3) Grind any pins (7, 11) dented with an oilstone or replace any pins abrasive excessively.
- (4) Check inside cover (2, 3, 17, 18) and collar (8, 9) for dents or scratches; if any damage is found, correct with a grinder or replace.
- (5) The serviceable limit of pins and bushings is shown in the table below. Unit : mm

Item No.	Name	Std dimension	Serviceable limit			Remedy
			Outer dia	Inner dia	Clearance	
7, 11	Pin	90	89.5	-	0.8	Replace
1	Tapered roller bearing		-	90.5		
8, 9	Collar		-	90.5		
12, 13	Dust seal	When removed				Replace

#### 4) ASSEMBLY

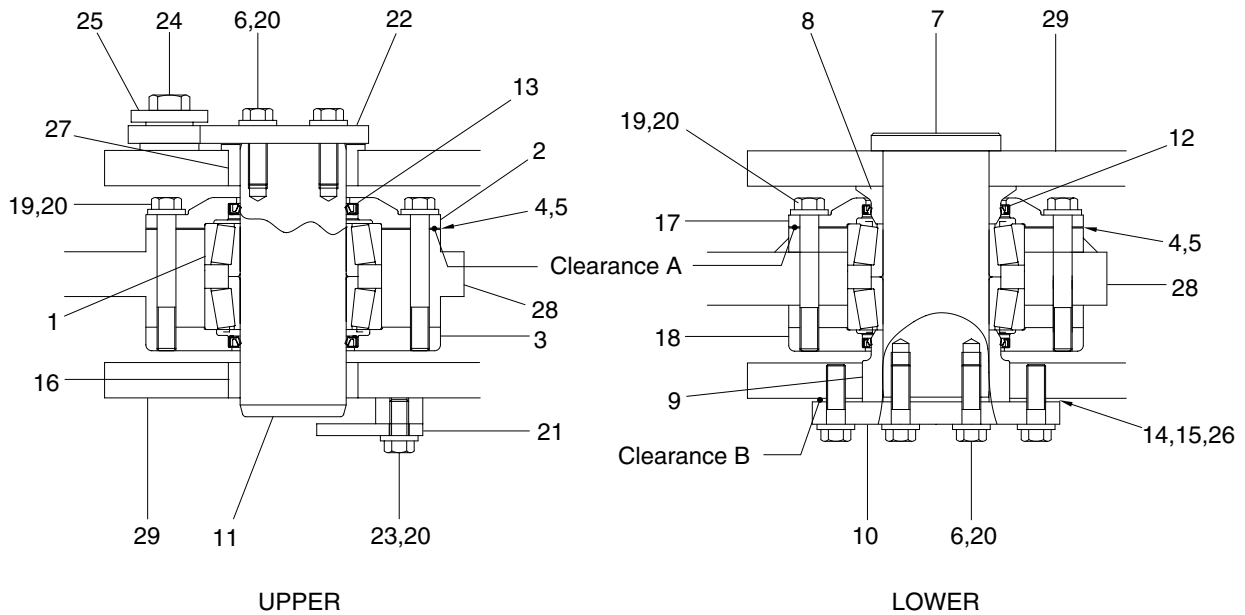

76095SE18

Assemble the center pivot group by reversing the order of disassembly while paying close attention to the following.

- (1) Put the dust seal (12,13) into cover (2, 3, 17, 18).
  - ※ Apply grease to the lip of the dust seal. Insert the dust seal so that the dust seal lip faces out and punch four places on the outer circumference of the seal to lock it.
- (2) Lower the temperature of the lower bearing cup to  $-75 \pm 5^{\circ}\text{C}$  ( $-103 \pm 9^{\circ}\text{F}$ ) and install it to front frame until it contacts the bottom of the frame.
- (3) Place the cover (3, 18).
- (4) Coat lightly with oil and install lower bearing in bore in front frame. Coat lightly with oil and install upper bearing in bore in upper front frame.
- (5) Place the cover (2, 17) and hold in place with bolt (19). At this time, adjust shims (4, 5) to press the shoulder of bearing (1) against retainer.
  - **Adjustment method of clearance A**
    - ① Install bearing (1) and cover (2, 17) without shim (4, 5)  
Install four of bolt (19) so that each bolt is separated by 90 degrees.
      - Tightening torque : 1.5~1.7 kgf · m (10.8~12.3 lbf · ft)
    - ② Adjust shims (4, 5) in order to control the clearance A.
      - Clearance A : Below 0.1 mm
      - Shim thickness : 0.1 mm, 0.5 mm

- (5) Apply grease to lower collar (8) and insert it to the lower of roller bearing.
- (6) After setting the bearing so that its upper surface is horizontal, tighten the all the bolt (19).  
After tightening, confirm that tapered roller bearing moves lightly ; if does not move smoothly, add shims (4, 5).
- Tightening Torque : 25.4~34.2 kgf · m (184~247 lbf · ft)
  - Apply loctite #243.
- (7) Move the front frame and join it to the rear frame so that match the pin hole at the center.
- (8) Apply grease to pin (11), bushing (27) and insert it into tapered roller bearing (1).
- (9) Apply grease to lower collar (9) and insert it to the lower of roller bearing through rear frame (29).
- (10) Apply grease to pin (7) and insert it into tapered roller bearing (1).
- (11) Before tightening bolt (6), adjust shims (14, 15) in order to control the clearance between the plate (21) and rear frame (29).
- **Adjustment method of clearance B**
  - ① Install pin (7) and plate (21) without shim (14,15, 27).  
Install four of bolt (6) so that each bolt is separated by 90 degrees.
    - Tighting torque : 1.5~1.7 kgf · m (10.8~12.3 lbf · ft)
  - ② Adjust shims in order to control the clearance B.
    - Clearance B : 0.1~0.2 mm
    - Shim thickness : 0.1 mm, 0.5 mm, 2.0 mm
- (12) Tighten the all the bolts (6).
- Tightening Torque : 25.4~34.2 kgf · m (184~247 lbf · ft)
  - Apply loctite #243.

## 5) TROUBLESHOOTING

Trouble	Probable cause	Remed
Shock is felt when steering	Capscrew for fixing steering valve is loose	Retighten
	Faulty center pivot pin mounting bolts	Retighten
	Center pivot pins have worn out	Readjust or replace
	Faulty hydraulic system	See hydraulic system
Shock is felt when moving backward or forward	Fault fixing of connecting capscrews	Retighten
	Center pins have worn out	Readjust or replace
	Bearings of support unit have worn out	Retighten
	Drive shaft damaged	See drive system
	Faulty transmission	See transmission system