

GROUP 4 DISASSEMBLY AND ASSEMBLY

1. CONTROL VALVE

1) DISASSEMBLY

- (1) Illustration on the right shows the complete control unit.

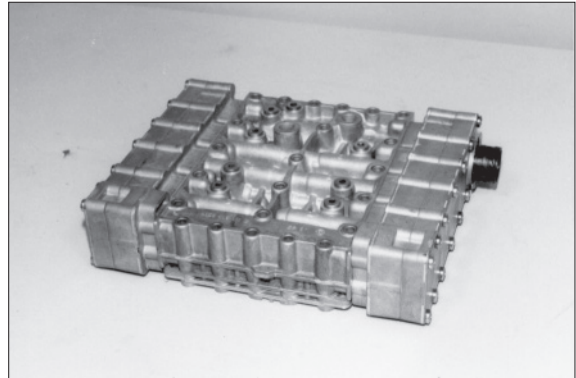

73073CV001

- (2) Mark the installation position of the different covers, the housing and cable harness with the valve housing.

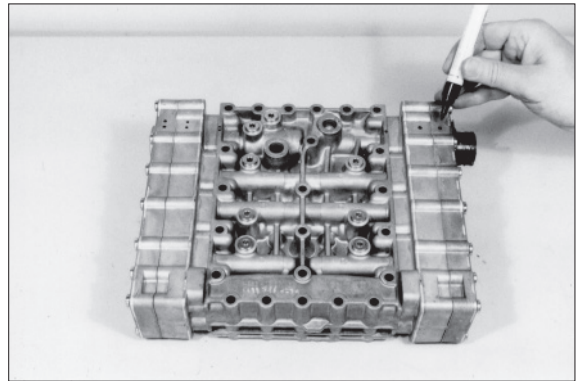

73073CV002

- (3) Loosen socket head screws.
Separate duct plate, 1st gasket, intermediate plate and 2nd gasket from the valve housing.
Box spanner 5873 042 002

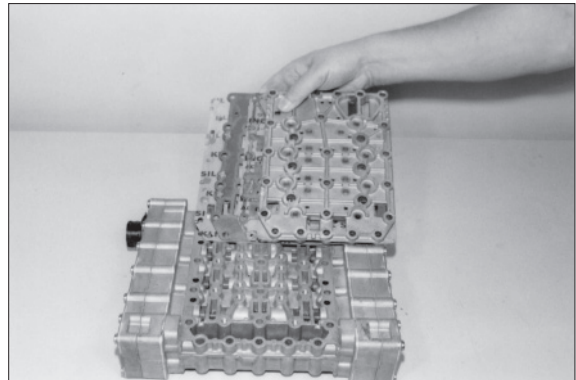

73073CV003

- (4) Remove retaining clip.

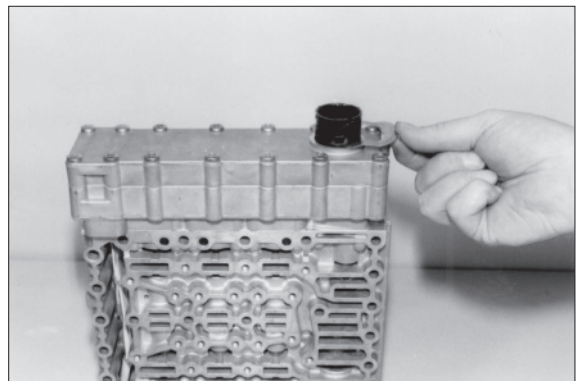

73073CV004

- (5) Loosen socket head screws.
Separate cover from housing and cable harness.
Box spanner 5873 042 002

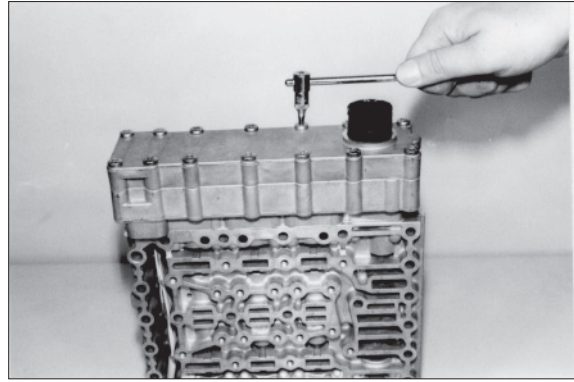

73073CV005

- (6) Disassemble opposite cover.
Disconnect pressure regulator and remove cable harness.

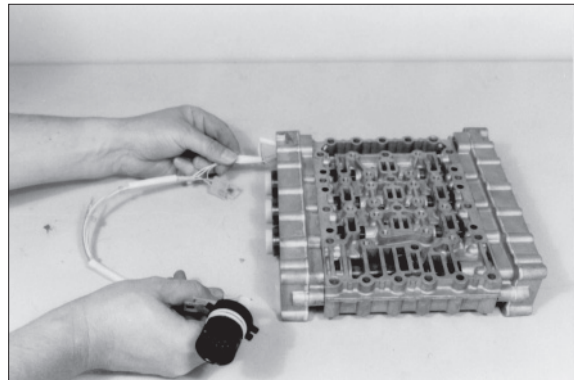

73073CV006

- (7) Loosen socket head screws, remove fixing plate and pressure regulators (3EA).
Box spanner 5873 042 002

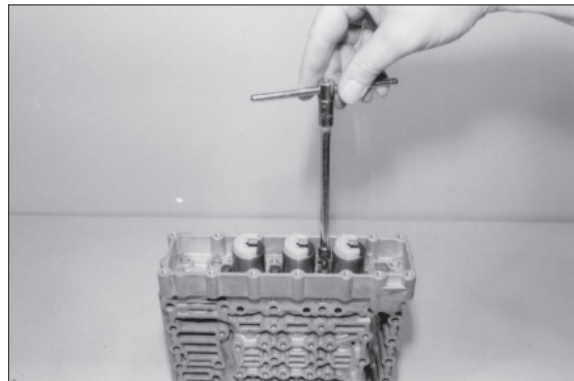

73073CV007

- (8) Loosen two socket head screws and locate housing provisionally, using adjusting screws (housing is under spring preload).
Now, loosen remaining socket head screws.
Box spanner 5873 042 002
Adjusting screws 5870 204 036

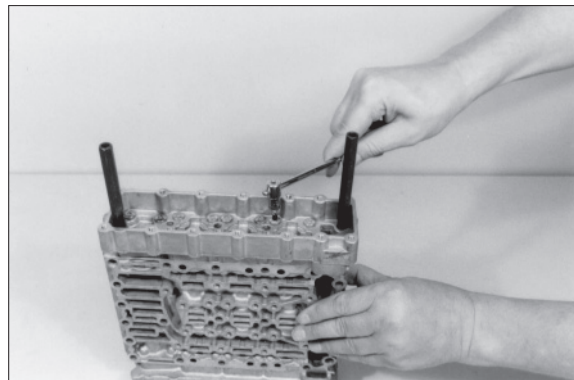

73073CV008

- (9) Separate housing from valve housing by loosening the adjusting screws uniformly.
Adjusting screws 5870 204 036

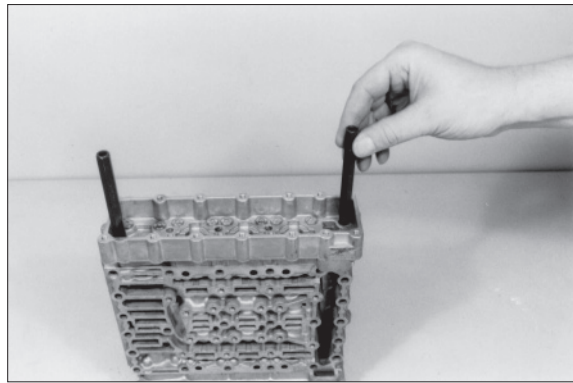

73073CV009

- (10) Remove components.

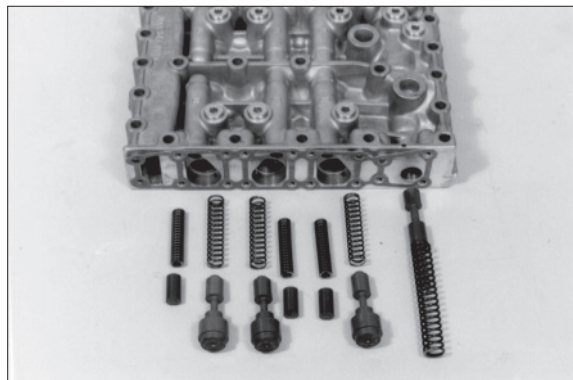

73073CV010

- (11) Remove opposite pressure regulators, housing as well as components accordingly.

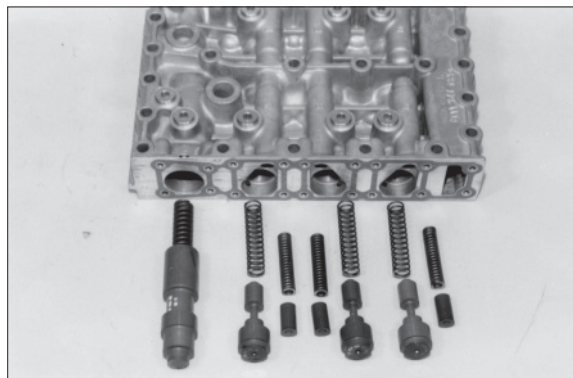

73073CV011

2) ASSEMBLY

- ※ Check all components for damage and renew if necessary.
Prior to the installation, check free travel of all moving parts in the housing.
Spools can be exchanged individually.
Oil the components prior to the assembly.
Insert diaphragms with the concave side showing upward until contact is obtained.
- ※ Installation position, see arrows.

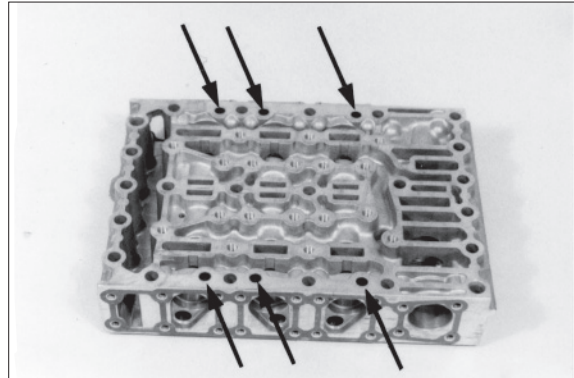

73073CV015

(1) Illustration on the right shows the following components.

- 1 Vibration damper
- 2 Follow-on slide
- 3 Pressure reducing valve

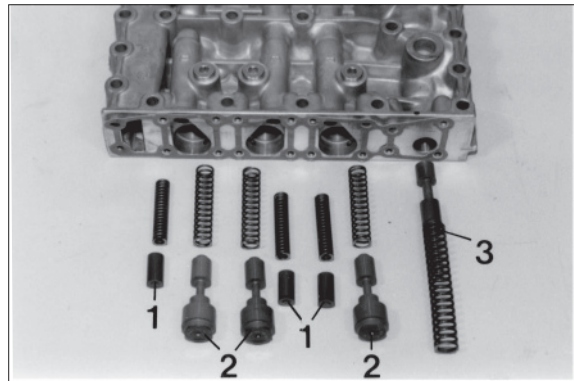

73073CV016

(2) Install components according to figure (1).

- ※ Preload compression spring of the follow-on slides and locate spool provisionally by means of cylindrical pins $\varnothing 5.0$ mm (assembly aid), see arrows.

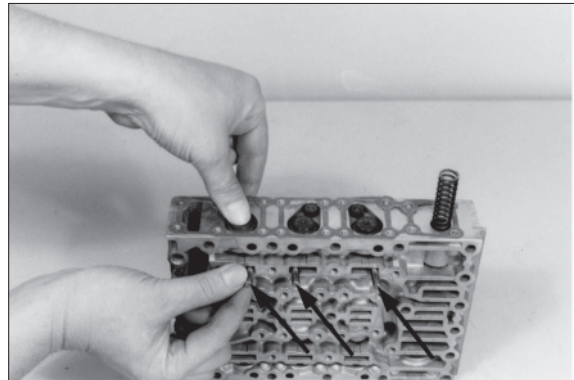

73073CV017

(3) Install two adjusting screws.

Assemble gasket (arrow 1) and housing cover. Now, position the housing cover uniformly, using adjusting screws, until contact is obtained and remove cylindrical pins (assembly aid) again (see the next figure).

- ※ Pay attention to the different housing covers.
Install recess $\varnothing 15$ mm (arrow 2), facing the spring of the pressure reducing valve.
Adjusting screws 5870 204 036

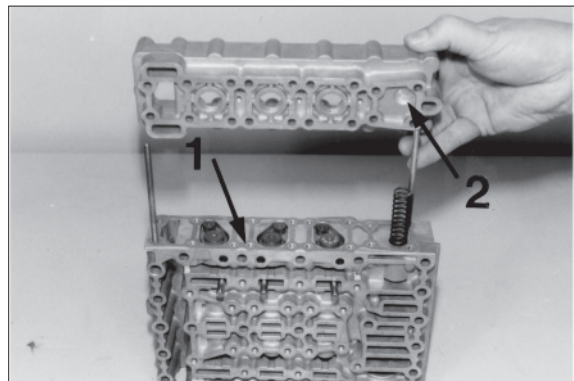

73073CV018

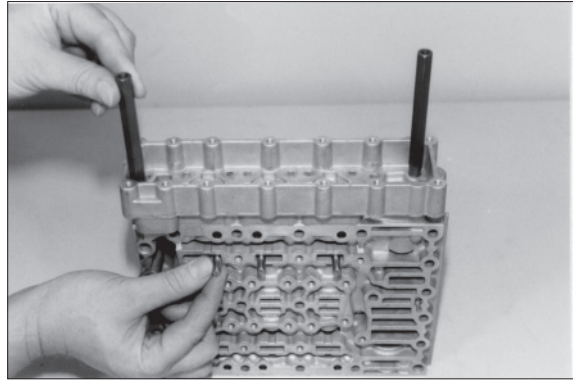

73073CV019

- (4) Fasten housing cover by means of socket head screws.
 · Torque limit : 0.56 kgf · m (4.06 lbf · ft)
 Box spanner 5873 042 002

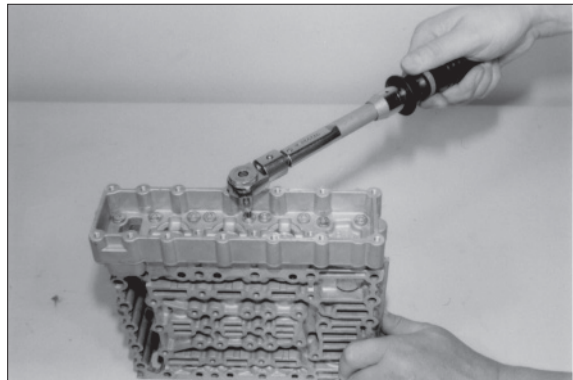

73073CV020

- (5) Introduce pressure regulators and fix by means of fixing plates and socket head screws.
 ※ Install fixing plate, with the claw showing downward.
 Pay attention to the radial installation position of the pressure regulators, see figure.
 · Torque limit : 0.56 kgf · m (4.06 lbf · ft)
 Box spanner 5873 042 002

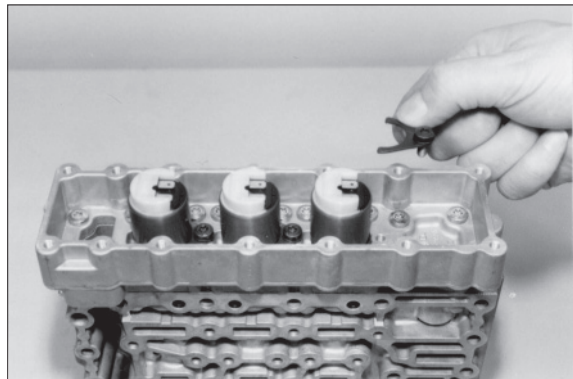

73073CV021

Pre assemble opposite side

- (6) Illustration on the right shows the following components.

- 1 Main pressure valve
- 2 Follow on slide
- 3 Vibration damper

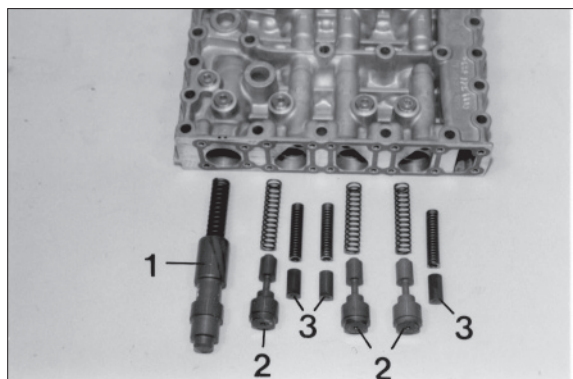

73073CV022

- (7) Install components according to figure (6).
Preload compression springs of the follow-on slides and locate spool provisionally by means of cylindrical pins $\varnothing 5.0$ mm (assembly aid), see arrows.
Install two adjusting screws.

Assemble gasket (arrow 1) and housing cover, and position them uniformly against shoulder, using adjusting screws.

- ※ Pay attention to the different housing covers-install the recess $\varnothing 19$ mm (arrow 2), facing the main pressure valve.
Now, fasten housing cover by means of socket head screws.

- Torque limit : 0.56 kgf · m (4.06 lbf · ft)

Remove cylindrical pins (assembly aid) again.

Adjusting screws 5870 204 036

Box spanner 5873 042 002

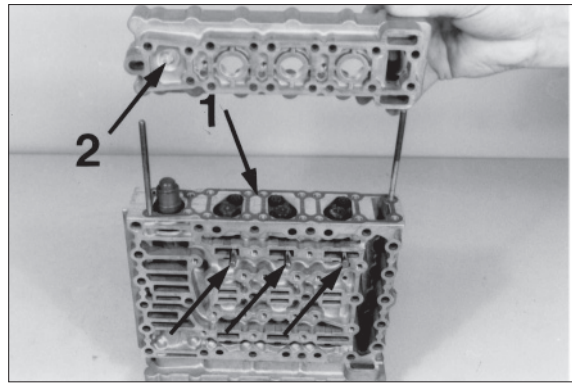

73073CV023

- (8) Introduce pressure regulators and fix by means of fixing plates and socket head screws.

- ※ Install fixing plates, with the claw showing downward.

Pay attention to the radial installation position of the pressure regulators, see figure.

- Torque limit : 0.56 kgf · m (4.06 lbf · ft)

Box spanner 5873 042 002

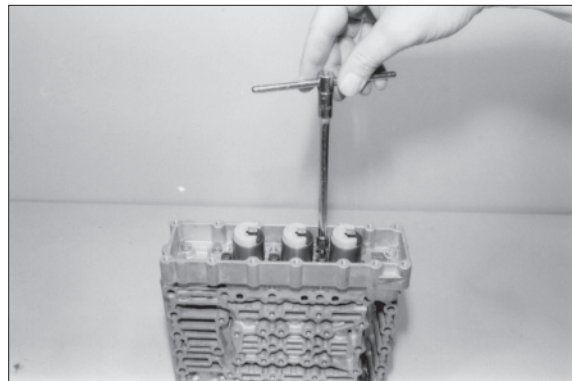

73073CV024

- (9) Introduce cable harness and connect pressure regulators (6EA).

- ※ Pay attention to the installation position of the cable harness, also markings (see figure (2), page 3-85).

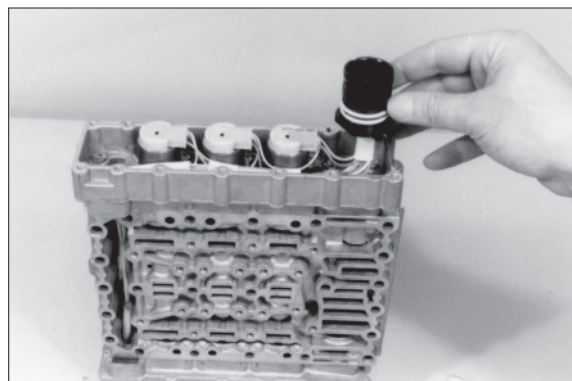

73073CV025

(10) Introduce female connector against shoulder, with the groove facing the guide nose of the cover.

Install gasket (arrow) and fasten cover by means of socket head screws.

· Torque limit : 0.56 kgf · m (4.06 lbf · ft)

Box spanner 5873 042 002

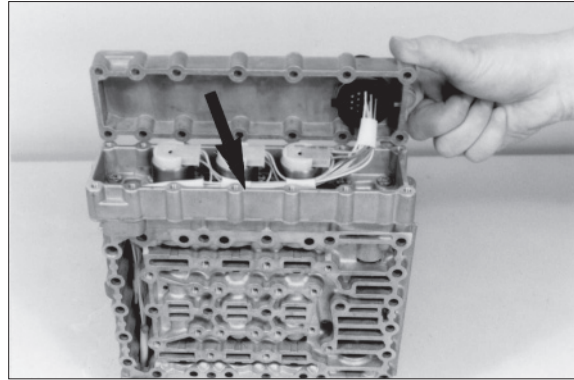

73073CV026

(11) Fix female connector by means of retaining clamp, see figure.

Install opposite cover.

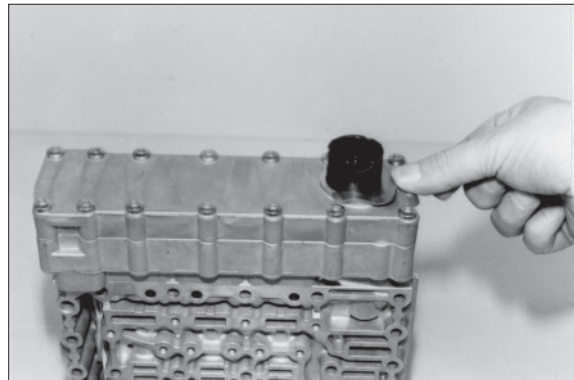

73073CV027

(12) Install two adjusting screws and mount gasket I.

※ Pay attention to the different gaskets, see on the right figure and (15).

Adjusting screws 5870 204 063

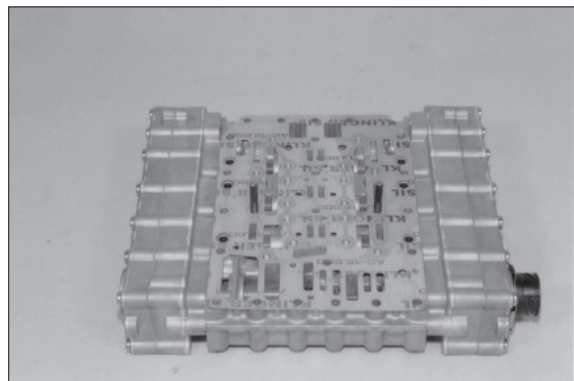

73073CV028

Intermediate plate-Version with screens

(13) Insert screws (6EA) flush mounted into the bore of the intermediate plate, see arrow.

※ Pay attention to the installation position-screws are showing upward (facing the duct plate).

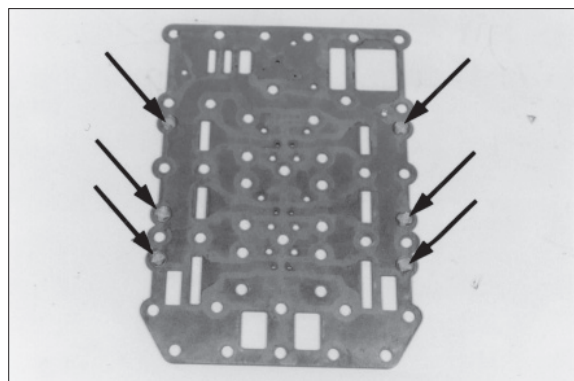

73073CV029

- (14) Mount intermediate plate, with the screens showing upward.

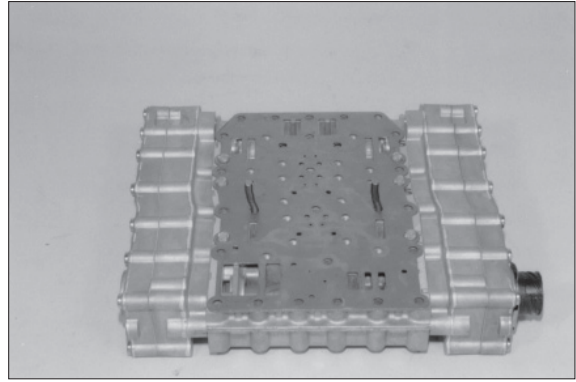

73073CV030

- (15) Mount gasket II.

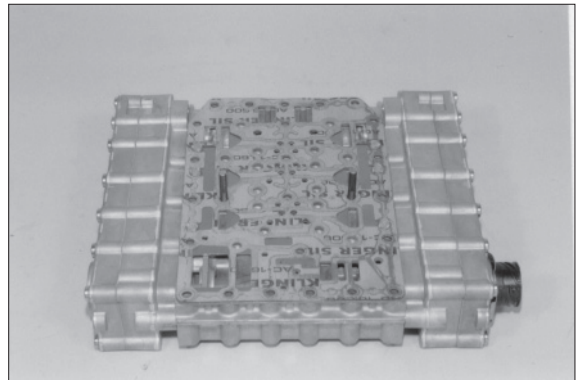

73073CV031

- (16) Mount duct plate and fasten it uniformly by means of socket head screws.

· Torque limit : 0.97 kgf · m (7.0 lbf · ft)

Box spanner 5873 042 002

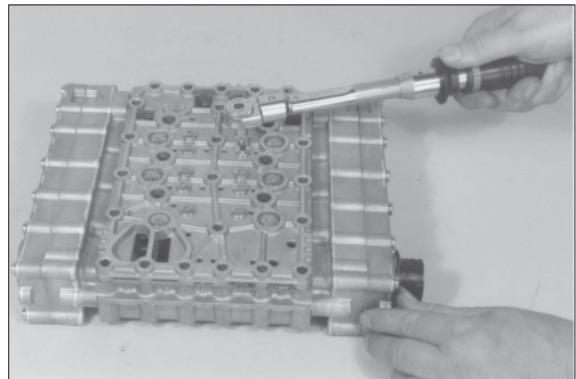

73073CV032

- (17) Equip screw plug (8EA) with new O-rings and install them.

· Torque limit : 0.56 kgf · m (4.06 lbf · ft)

- ※ The installation of the hydraulic control unit is described, starting from page 3-142.

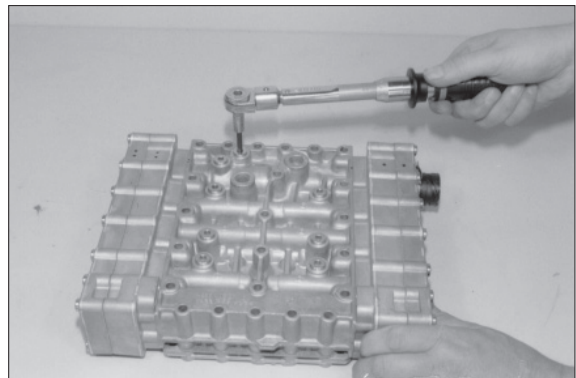

73073CV033

2. POWERSHIFT TRANSMISSION

Fasten transmission of the assembly car.

Assembly car 5870 350 000

Strips 5870 350 063

Support 5870 350 090

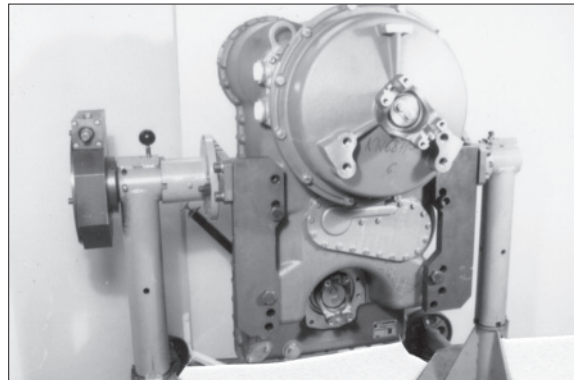

75773TM050

1) DISASSEMBLY

(1) Separate hydraulic control unit and duct plate from gearbox housing

- ① Loosen two socket head screws and install adjusting screws.

Now, loosen remaining socket head screws and separate valve housing from duct plate.

Adjusting screws (M6) 5870 204 063

Box spanner 5873 042 002

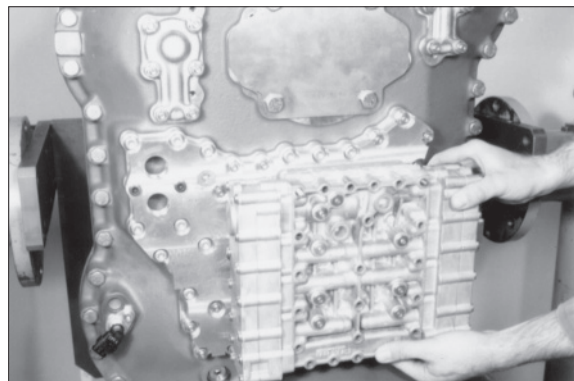

75773TM051

- ② Remove both gaskets and intermediate plate.

Loosen socket head screws as well as hexagon nuts and separate duct plate from gearbox housing.

Now, remove gasket.

Box spanner 5873 042 004

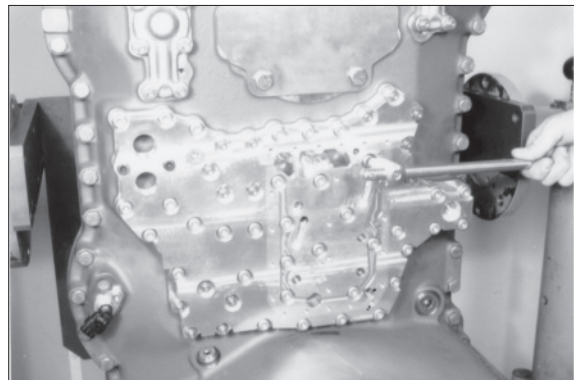

75773TM052

- ③ Pull converter safety valve out of the housing bore.

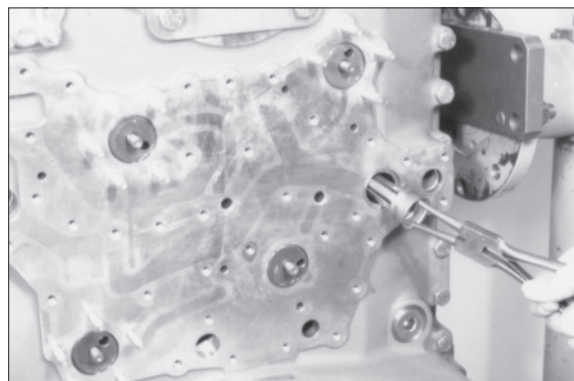

75773TM053

(2) Converter

- ① Loosen hexagon head screws and separate diaphragm from the converter.

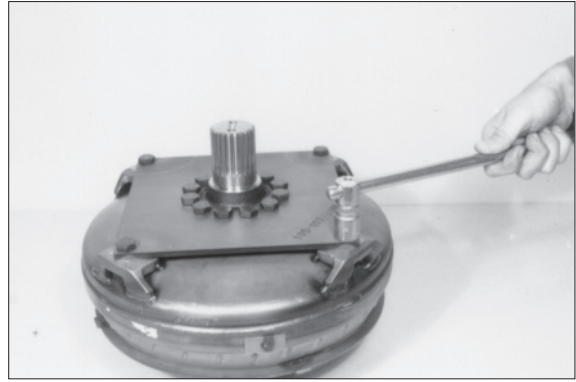

75773TM060

- ② Loosen hexagon head screws and separate drive shaft from the diaphragm.

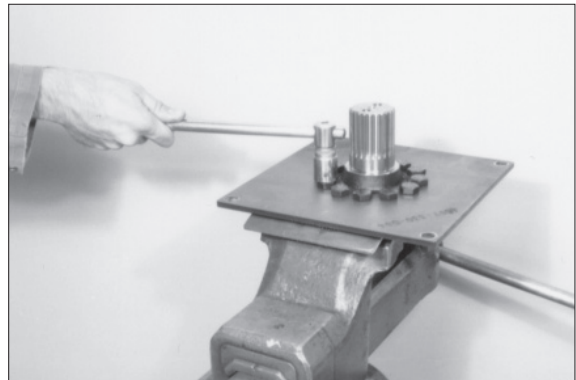

75773TM061

- ③ Remove inductive transmitter (engine).

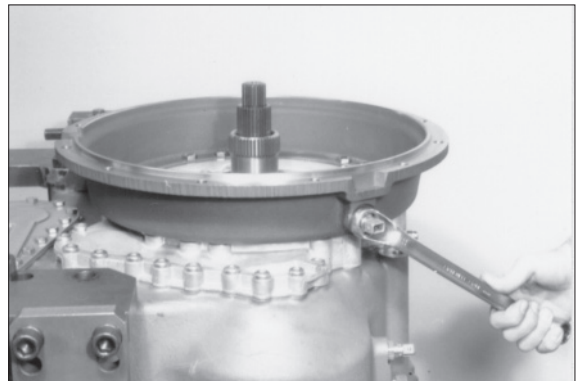

75773TM062

- ④ Loosen hexagon head screws and remove converter bell.

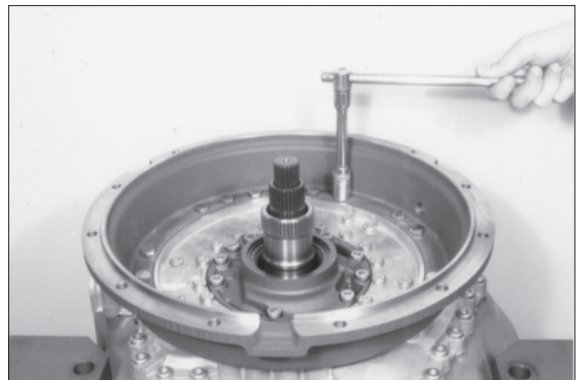

75773TM063

(3) Hydraulic pump

- ① Loosen socket head screws.

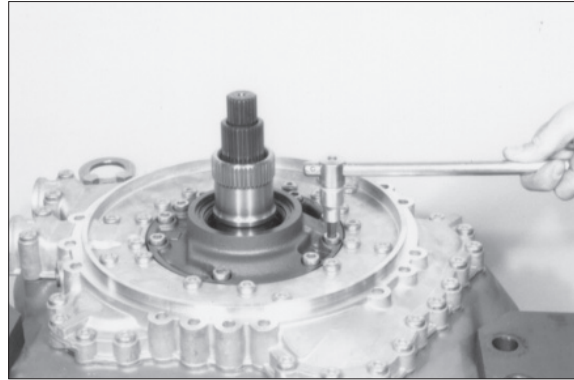

75773TM064

- ② Apply separating device on the gear teeth runout of the stator shaft and pull pump (compl.) by means of two leg puller carefully out of the housing bores.

Separating device 5870 300 024

Two leg puller 5870 970 004



75773TM065

- ③ Separate hydraulic pump from stator shaft.

Separate control disk from pump.

- ※ If traces due to running in should be encountered in the pump housing or on the control disk, the complete pump has to be renewed.

Now, lay on control disk again and fix it by means of grooved pins (2EA).

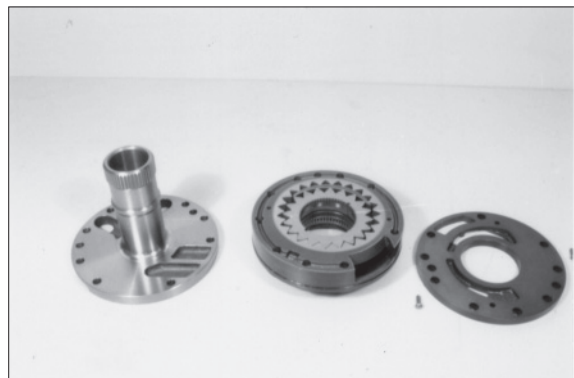

75773TM066

- ④ Loosen socket head screws as well as two hexagon head screws and remove oil feed housing.

Now, remove gasket.

Box spanner 5873 024 004

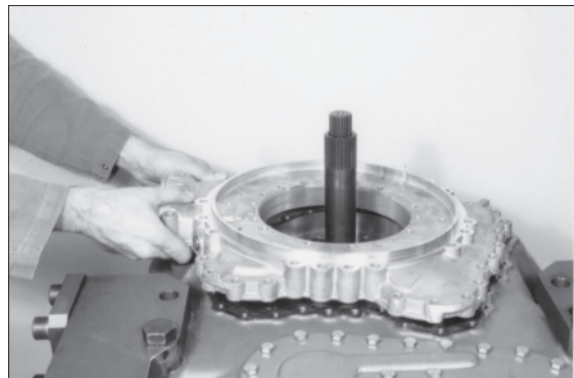

75773TM067

(4) Converter back pressure valve

- ① Preload compression spring and remove lock plate.
Remove released components.

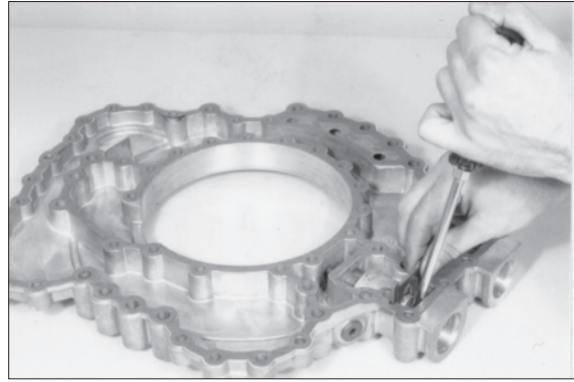

75773TM068

- ② Loosen hexagon head screws.
Remove cover and gasket.

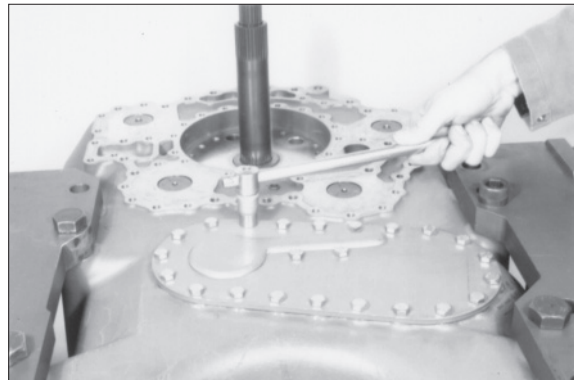

75773TM069

(5) Remove output, input and clutches

- ① Remove lock plate, loosen hexagon head screws and pry converter side output flange off the shaft.
Now, pry shaft seal out of the housing bore.
Tilt transmission 180° and remove rear side output flange accordingly.
Pry bar 5870 345 065

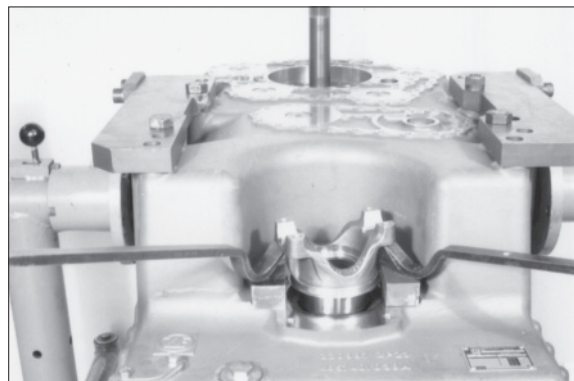

75773TM075

- ② Remove speed sensor as well as both inductive transmitters (arrows).

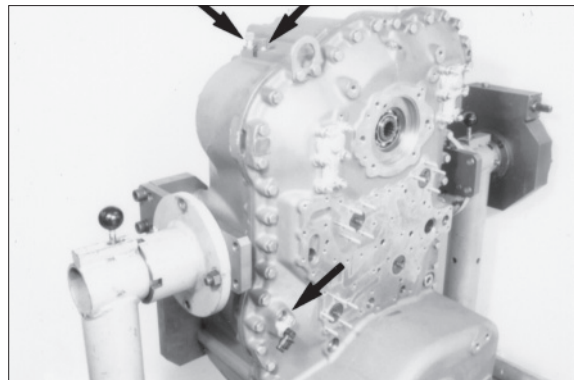

75773TM076

- ③ Loosen hexagon nuts and remove both covers (arrows).
Loosen screw connection (housing/
housing cover).

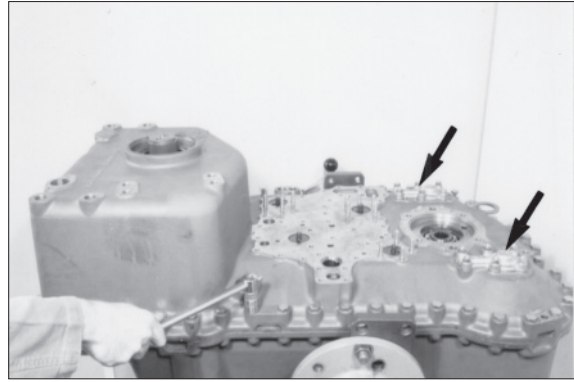

75773TM077

- ④ Drive both cylindrical pins out (arrows).

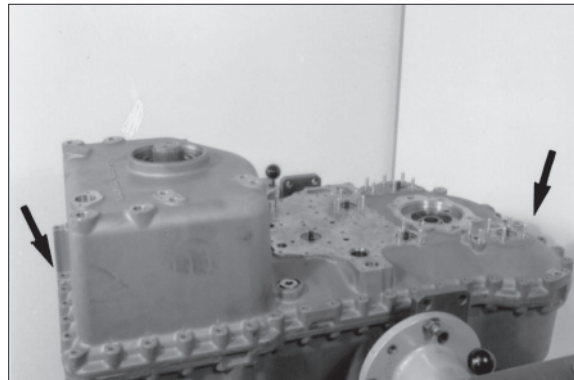

75773TM078

- ※ The following figures show the common
removal of all clutches.
The removal of single clutches without
use of the special tool (handles 5870
260 010) is due to the installation
conditions extremely difficult.

Besides there is the danger of injuries.

- ⑤ Locate all clutches by means of handles
in the housing cover.
Install eye bolts and hang in the lifting
device.

Handle (6 pieces needed)	5870 260 010
Eye bolt (M20, 2EA)	0636 804 003
Eye bolt (M16, 1EA)	0636 804 001
Puller device	5870 000 017
Lifting chain	5870 281 047

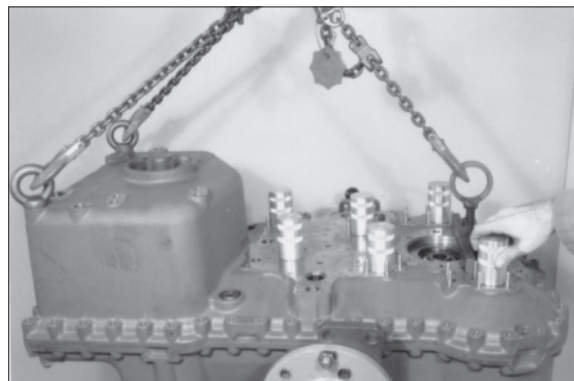

75773TM080

- ⑥ Separate housing cover along with clutches from the gearbox housing, using lifting device.

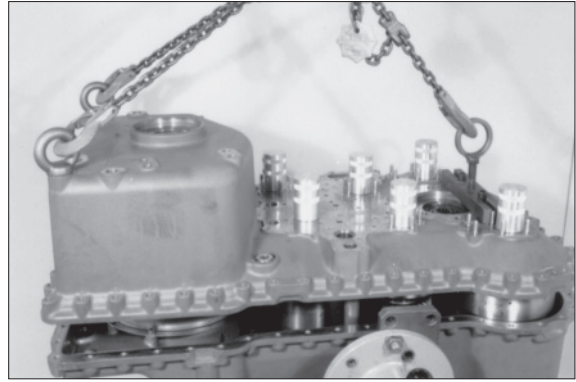

75773TM081

- ⑦ Fasten housing cover on the assembly car.

Assembly car	5870 350 000
Clamping bracket	5870 350 089

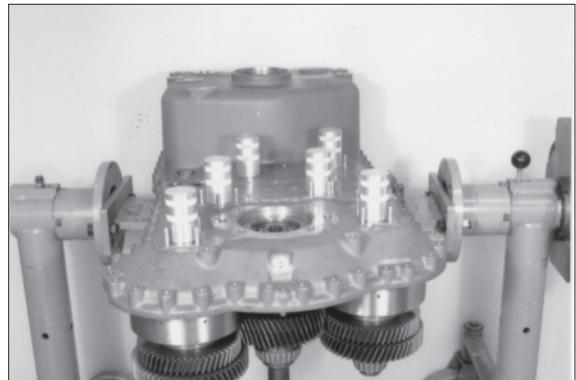

75773TM082

- ⑧ Loosen socket head screws and remove output shaft as well as the two oil collecting plate.

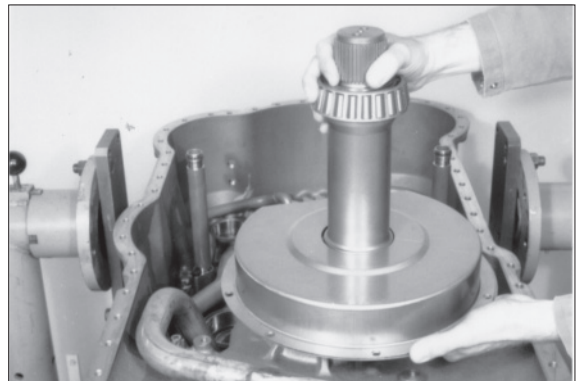

75773TM083

- ⑨ Pull off tapered roller bearing.
Remove opposite tapered roller bearing accordingly.
- | | |
|-------------|--------------|
| Grab sleeve | 5873 002 038 |
| Basic set | 5873 002 001 |



75773TM084

⑩ Tilt housing cover 180°.

Illustration on the right shows the arrangement of the single clutches and the input in the housing cover.

AN	Input
KV	Clutch-Forward
KR	Clutch-Reverse
K1	Clutch-1st speed
K2	Clutch-2nd speed
K3	Clutch-3rd speed
K4	Clutch-4th speed

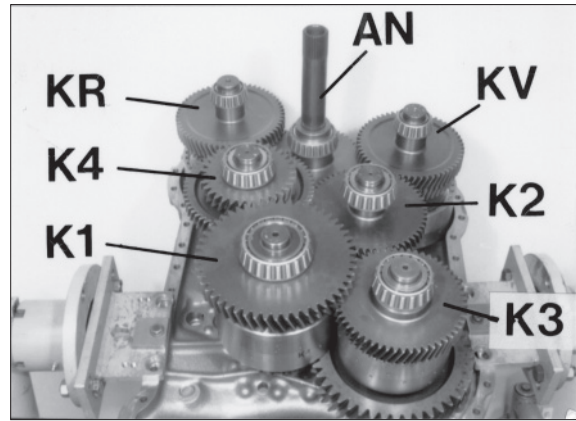

75773TM085

⑪ Remove handles (see figure).

Handles 5870 260 010

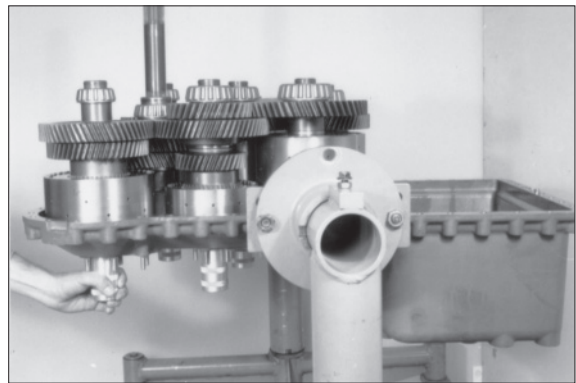

75773TM086

⑫ Lift clutch K4 a bit by means of pry bars and remove clutch K1.

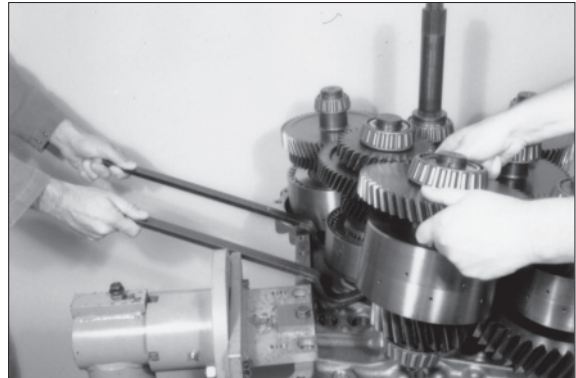

75773TM087

⑬ Remove clutch K2.

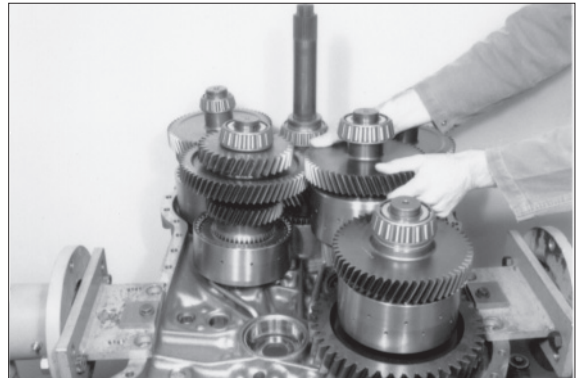

75773TM088

- ⑭ Remove clutch K3.

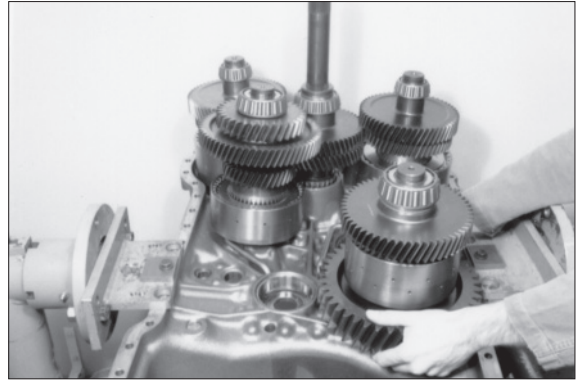

75773TM089

- ⑮ Lift clutch KV and KR by means of pry bars and remove clutch K4.

Pry bar 5870 345 065



75773TM090

- ⑯ Lift clutch KV and clutch KR as well as input together out of the housing cover. Remove bearing outer races out of the housing bores.

- ※ If contrary to the recommendation the tapered roller bearings of the clutches as well as of the input and output will not be renewed, the allocation (bearing inner races to bearing outer races) must at least be maintained.

Mark bearing inner race and bearing outer race accordingly to each other.

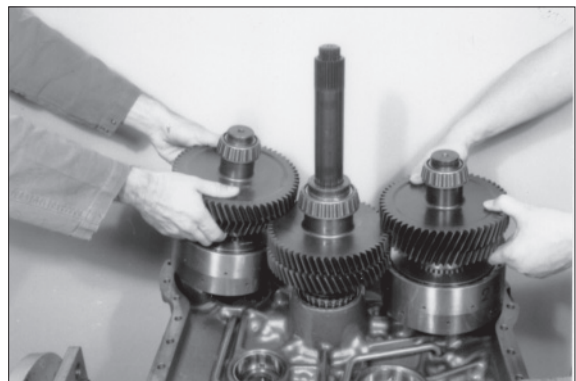

75773TM091

- ⑰ Tilt housing cover 90°.

Squeeze circlip out and separate pump shaft from housing cover.



75773TM092

- ⑮ Squeeze rectangular ring out (arrow) and press ball bearing from the shaft.

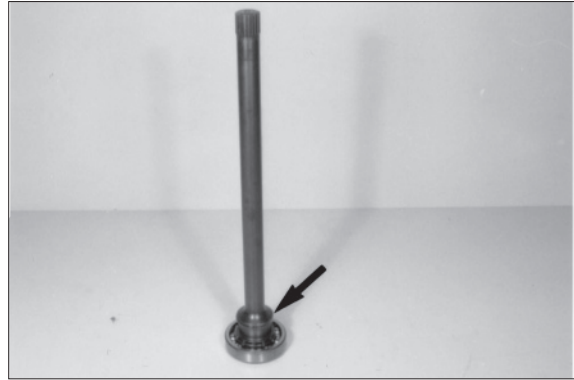

75773TM093

(6) Disassemble clutch KV and KR

※ The following figures show the disassembly of clutch KV.

- ① The disassembly of clutch KR is similar. Squeeze rectangular ring out (arrow).



75773TM095

- ② Pull tapered roller bearing from the shaft. Remove opposite tapered roller bearing accordingly.

Grab sleeve	5873 001 057
Grab sleeve	5873 001 059
Basic set	5873 001 000



75773TM096

- ③ Squeeze circlip out.



75773TM097

- ④ Separate plate carrier from the shaft.
Three leg puller 5870 971 003



75773TM098

- ⑤ Squeeze snap ring out and remove plate pack.

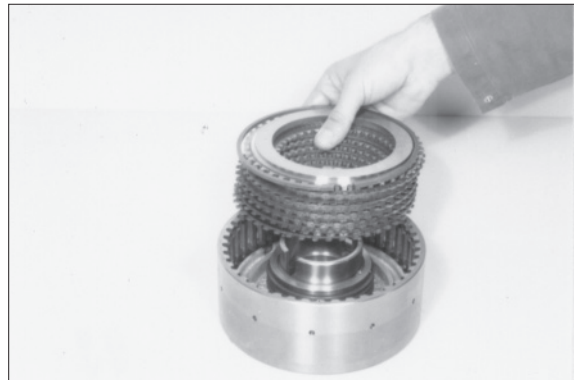

75773TM099

- ⑥ Preload compression spring, squeeze snap ring out and remove components.
Assembly aid 5870 345 088



75773TM100

- ⑦ Lift piston by means of compressed air out of the cylinder bore and remove it.

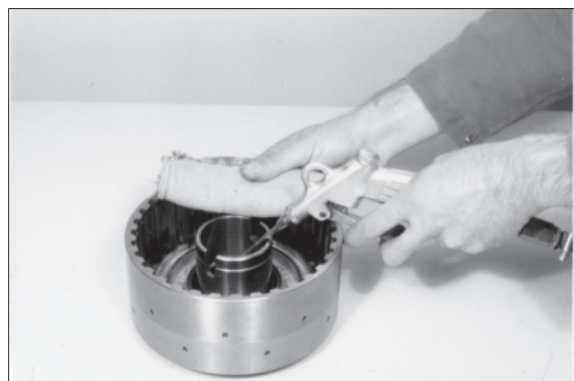

75773TM101

- ⑧ Remove both O-rings (arrows).

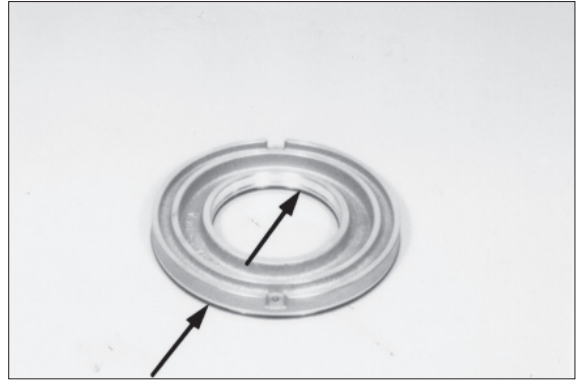

75773TM102

- ⑨ Lift idler gear a bit by means of pry bare.

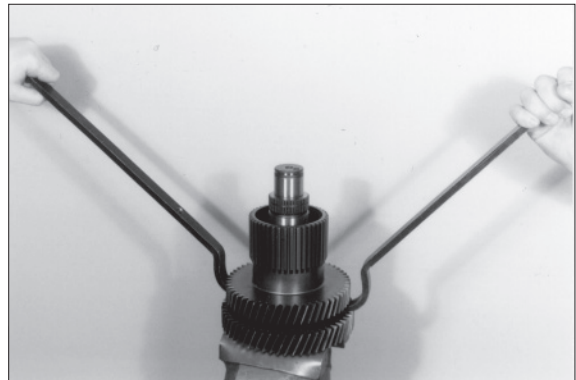

75773TM103

- ⑩ Apply puller and separate idler gear from the clutch shaft.

Pry bar

5870 345 065

Puller

5870 971 003



75773TM104

- ⑪ Squeeze circlip out and remove ball bearing.

- ※ The disassembly of clutch KR has to be carried out accordingly.

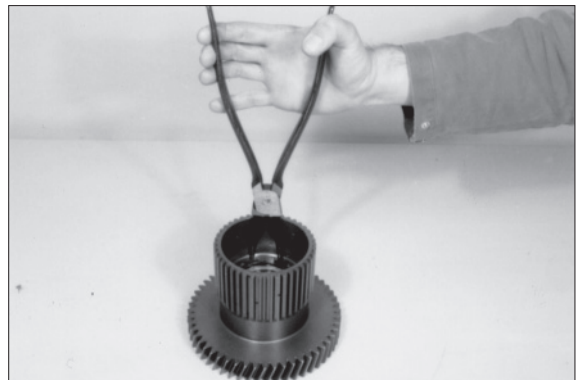

75773TM105

(7) Disassemble clutch K1, K2 and K3

※ The following figures show the disassembly of clutch K3.

The disassembly of the clutches K1 and K2 is similar.

① Squeeze rectangular ring out.

Pull tapered roller bearing from the shaft.
Remove the opposite tapered roller bearing accordingly.

Grab sleeve (bearing 33800) 5873 001 059

Grab sleeve (bearing 39500) 5873 002 038

Basic set 5873 001 000

Basic set 5873 002 001

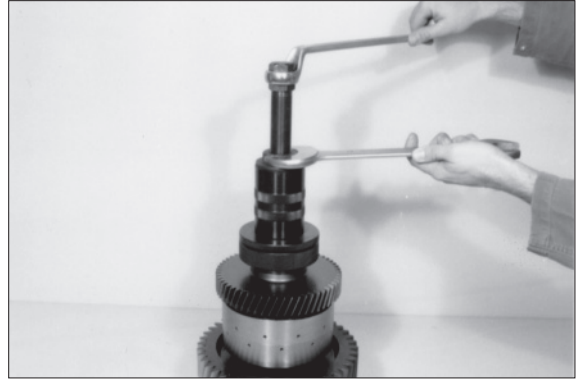

75773TM110

② Remove running disk, axial needle cage and axial washer.



75773TM111

③ Remove idler gear.

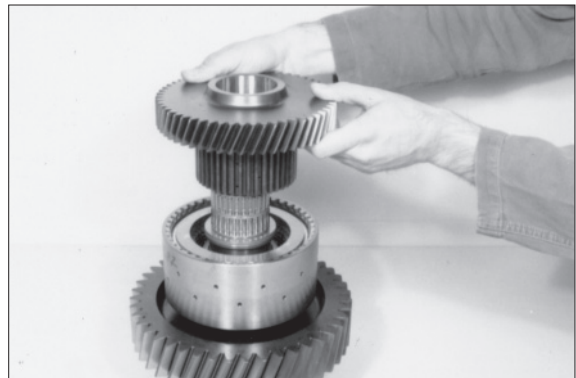

75773TM112

- ④ Remove both needle bearings as well as the axial bearing (complete).

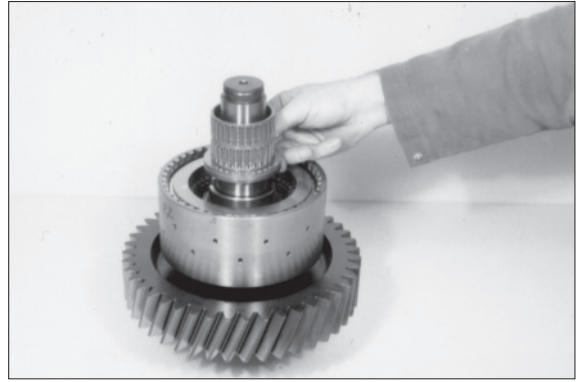

75773TM113

- ⑤ Squeeze snap ring out and remove plate pack.



75773TM114

- ⑥ Preload cup-spring pack and squeeze snap ring out.
Remove released components.
Assembly aid 5870 345 088

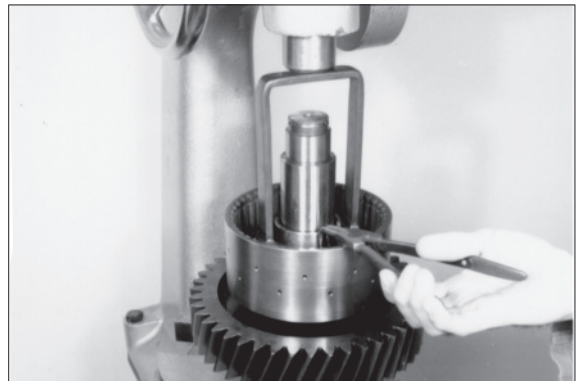

75773TM115

- ⑦ Squeeze circlip into the groove of the plate carrier.
Apply puller on the circlip and pull plate carrier from the clutch shaft.
Puller 5870 970 004
Circlip 0630 502 053



75773TM116

(8) Disassemble clutch K4

- ① Squeeze rectangular ring out (arrow).



75773TM120

- ② Pull tapered roller bearing from the shaft.
Remove opposite tapered roller bearing accordingly.

Grab sleeve 5873 001 057

Grab sleeve 5873 001 059

Basic set 5873 001 000



75773TM121

- ③ Squeeze circlip out and separate plate carrier from the shaft.

Three leg puller 5870 971 003

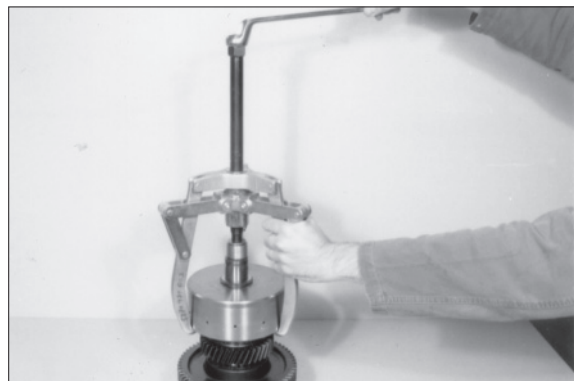

75773TM122

- ④ Squeeze snap ring out and remove plate pack.



75773TM123

- ⑤ Preload cup-spring pack and squeeze snap ring out.
Remove released components.
Remove piston.
Assembly aid 5870 345 008



75773TM124

- ⑥ Lift piston by means of compressed air out of the cylinder bore and remove it.

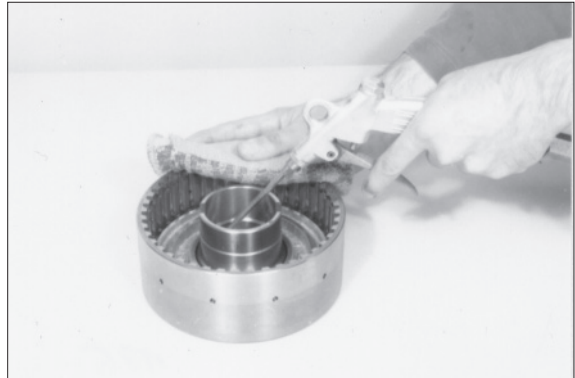

75773TM125

- ⑦ Take off the idler gear and remove release components.
※ The separation of shaft and gear is not possible (shrink fit).

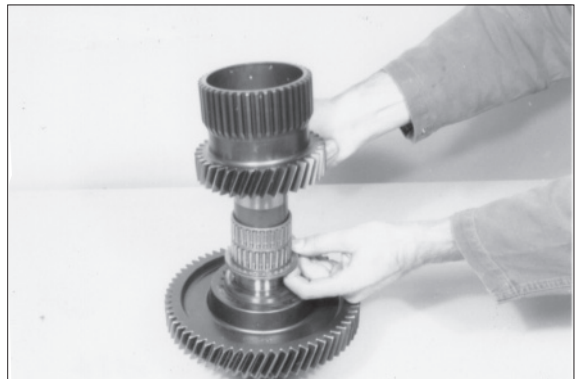

75773TM126

(9) Disassemble drive shaft

- ① Squeeze rectangular ring out.
Pull off tapered roller bearing.
Remove opposite tapered roller bearing accordingly.
Grab sleeve 5873 002 045
Basic set 5873 002 001
Basic set 5873 002 006



75773TM130

- ② If necessary, press turbine shaft out of the drive shaft.
※ The turbine shaft is axially fixed with a snap ring which will be destroyed at the pressing out.

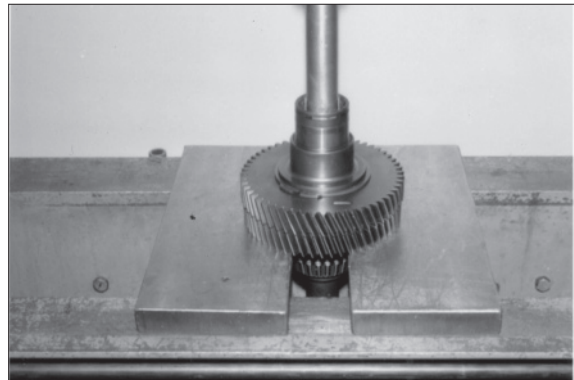

75773TM131

2) REASSEMBLY

(1) Install oil tubes

- ※ To ensure the correct installation of the oil tubes, the use of the indicated special tool is imperative.

- ① Insert suction pipe (1), pressure pipes (2) and pressure pipelubrication (3) into the housing bores.

Fasten suction and pressure pipes by means of socket head screws.

- Torque limit : 2.3 kgf · m (17.0 lbf · ft)

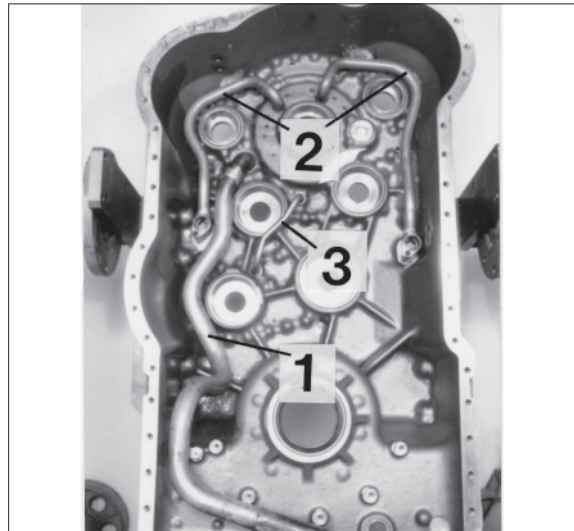

75773TM140

- ② Tilt housing 180°.

Roll suction as well as pressure pipes (arrows) into the housing bores, using special tool.

The pipe end must be maximally plane with the housing face.

If necessary, equalize projection of pipe.

Rolling tool 5870 600 003

Rolling tool 5870 600 005

Rolling tool 5870 600 007

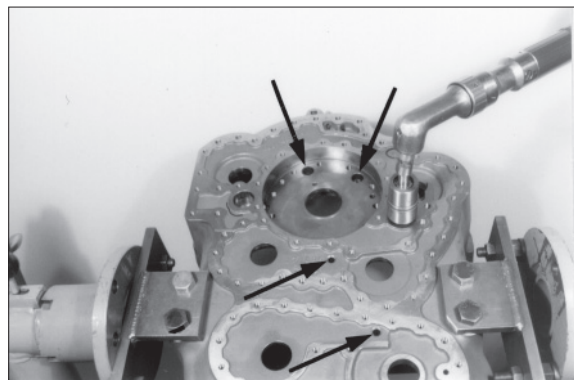

75773TM141

- ③ Insert O-rings (2EA/pipe) into the annular grooves of the two oil tubes and oil them.

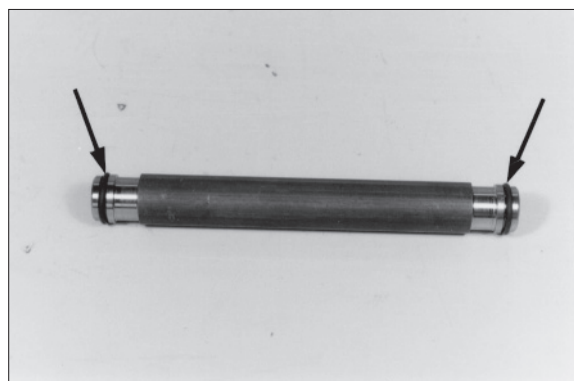

75773TM142

(2) Reassemble clutch KV and KR

- ※ The following figure show the reassembly of the clutch KV. The reassembly of the clutch KR has to be carried out accordingly.

Preassemble plate carrier

- ① Check function of the purge valve.
 - ※ Ball must not stick, if necessary, clean with compressed air.

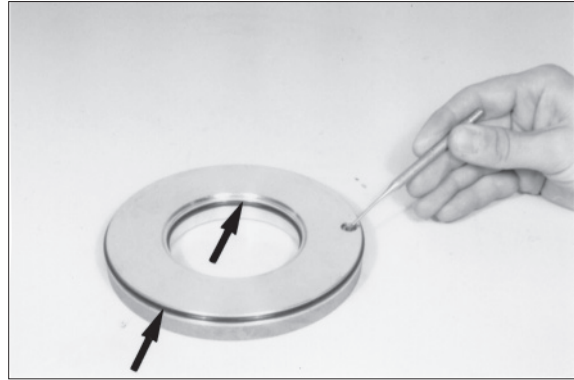

75773TM150

- ② Insert both O-ring (arrows) scrollfree into the grooves of the piston and oil. Introduce piston until contact is obtained.
 - ※ Pay attention to the installation position, see figure.

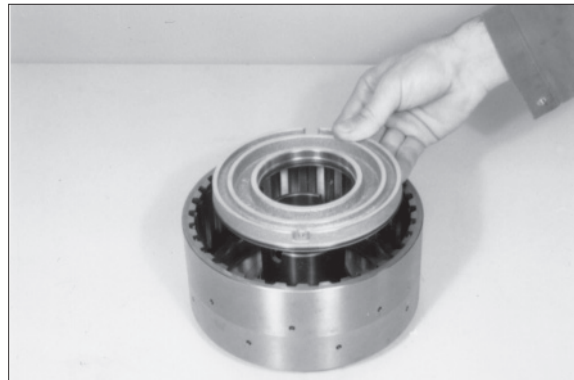

75773TM151

- ③ Install disk, compression spring and guide ring.



75773TM152

- ④ Preload compression spring and fix it by means of snap ring.
Assembly aid 5870 345 088



75773TM153

Plate pack KV, KR

- ※ The plate arrangement respectively stacking of clutch KV and KR is identical.
- ⑤ The following draft shows the installation position of the components.

- 1 Plate carrier
- 2 Piston
- 3 Outer plate-one sided coated (1 piece)
- 4 Inner plates (10 pieces)
- 5 Outer plates-coated on both sides (10 pieces)
- 6 Snap ring (optional $s = 2.1 \sim 4.2$ mm)
- 7 End shim

Effective number of friction surfaces = 20

- ※ Install outer plate 3 with the uncoated side facing the piston.
- Install on the end-shim side two outer and inner plates each.

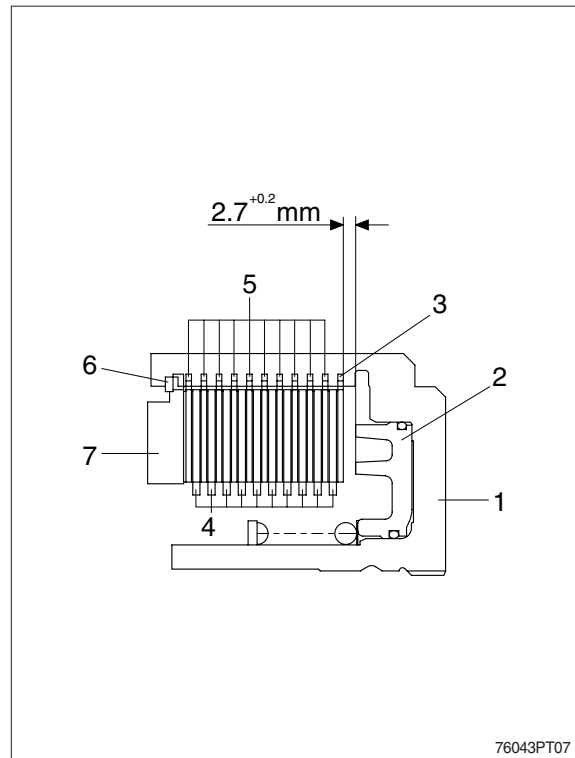

76043PT07

Adjust plate clearance : $2.7+0.2$ mm

- ※ For the adjustment of the plate clearance are snap rings of different thickness available.
- To ensure a faultless measuring result, install plates for the moment without oil.
- ⑥ Introduce plate pack according to the upper draft.

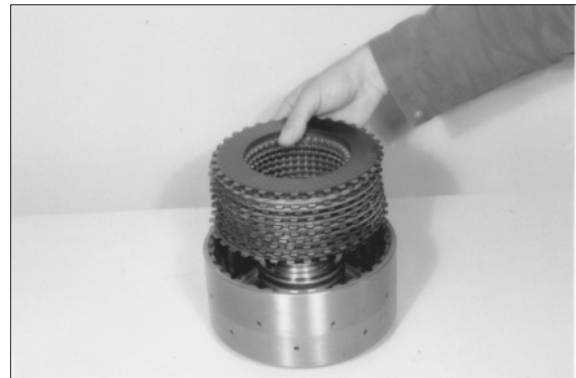

75773TM155

- ⑦ Lay on the end shim and squeeze the snap ring in (e.g. $s = 2.55$ mm)

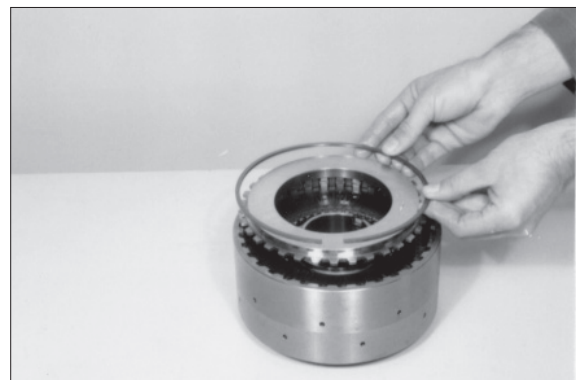

75773TM156

- ⑧ Press on end shim with about 100N (10 kg), apply dial indicator and set it at zero.

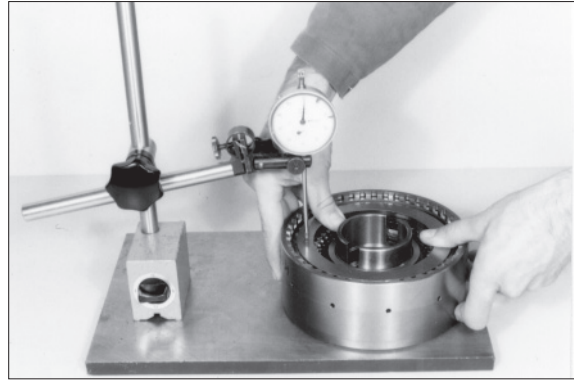

75773TM157

- ⑨ Now, push the end shim by means of screw driver against snap ring until contact is obtained (upward) and read plate clearance on the dial indicator.

※ In case of a deviation from the required plate clearance, correct with corresponding snap ring (s = 2.1~4.2 mm).

※ After the adjustment of the plate clearance has been carried out, remove the plate pack, oil plates and install it again. Use oil SAE 10W-30/15W-40.

Magnetic stand 5870 200 055
Dial indicator 5870 200 057

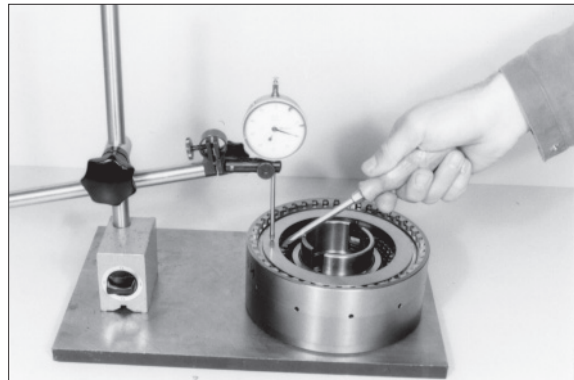

75773TM158

- ⑩ Introduce idler gear until all inner plates are accommodated.

※ This step makes the later assembly of the idler gear easier.

Now, remove the idler gear again.



75773TM159

- ⑪ Mount stud (arrow).
Wet screw-in thread with loctite (type No.241).
· Torque limit (M10) : 1.7 kgf · m
(12.5 lbf · ft)

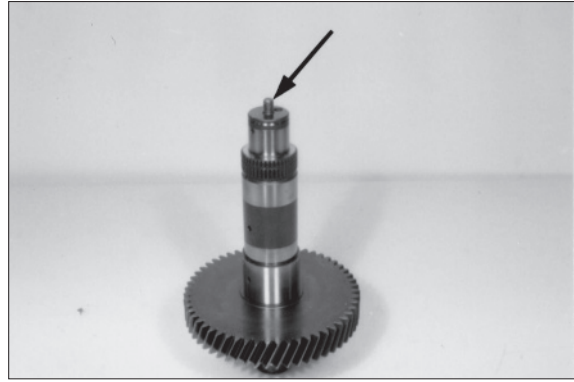

75773TM160

- ⑫ Insert ball bearing until contact is obtained and fix by means of circlip.



75773TM161

- ⑬ Assemble needle bearing.

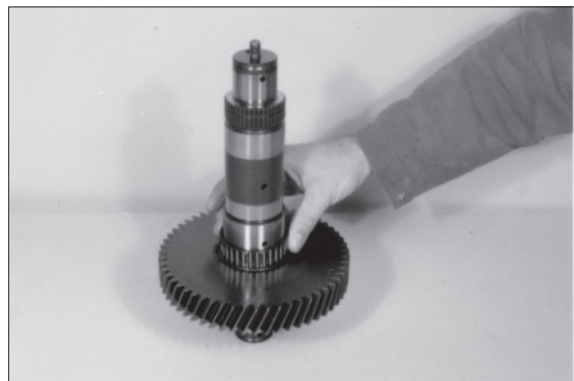

75773TM162

- ⑭ Press idler gear against shoulder.
※ Support it on the bearing inner race.

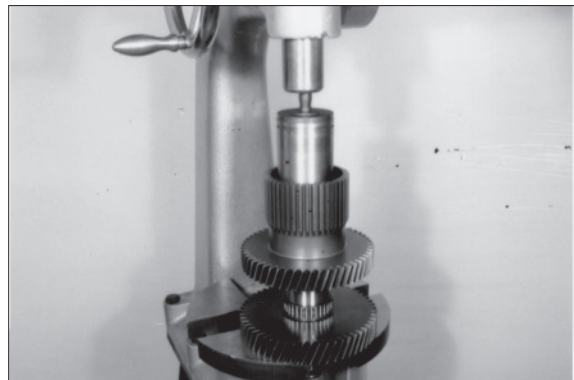

75773TM163

- ⑮ Heat inner diameter of plate carrier
(About 120°C).
Hot air blower 220V 5870 221 500
Hot air blower 110V 5870 221 501



75773TM164

- ⑯ Assemble preassembled plate carrier
until contact is obtained.



75773TM165

- ⑰ Locate plate carrier axially by means of
circlip.



75773TM166

- ⑱ Check function of clutch by means of
compressed air.
※ At correctly installed components, the
closing resp. opening of the clutch is
clear audible.



75773TM167

- ① Press tapered roller bearing against shoulder.
Install opposite tapered roller bearing accordingly.



75773TM168

- ② Squeeze rectangular rings in (arrow) and let them snap in.

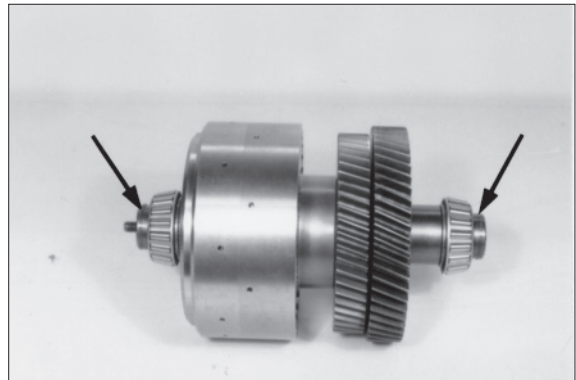

75773TM169

(3) Reassemble clutch K1, K2 and K3

- ※ The following figures show the reassembly of clutch K3.

The reassembly of the clutches K1 and K2 has to be carried out accordingly.

- ① Install stud (arrow).
※ Wet screw in thread with loctite (type No. 241).
· Torque limit (M10) : 1.7 kgf · m (12.5 lbf · ft)



75773TM175

- ② Heat inner diameter of plate carrier.



75773TM176

- ③ Assemble plate carrier until contact is obtained.

Hot air blower 220V 5870 221 500

Hot air blower 110V 5870 221 501



75773TM177

- ④ Check function of the purge valve.

※ Ball must not stick, if necessary clean with compressed air.

Insert both O-rings (arrows) scrollfree into the grooves of the piston and oil.

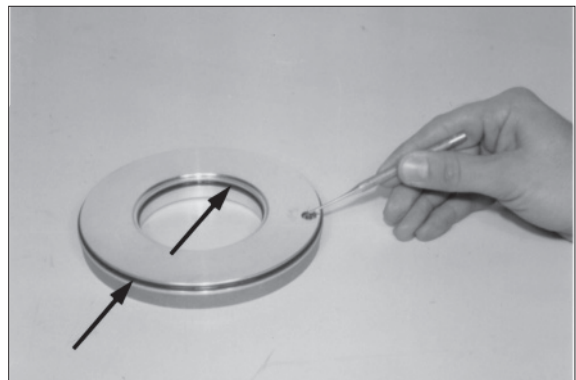

75773TM178

- ⑤ Introduce piston until contact is obtained.

※ Pay attention to the installation position, see figure.

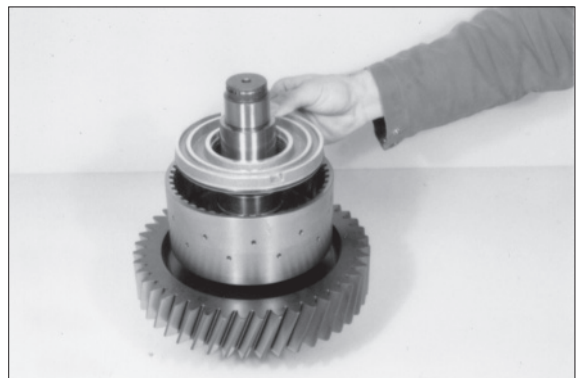

75773TM179

- ⑥ Lay on cup spring pack and guide ring.

※ Pay attention to the stacking of the cup springs, see the next draft.

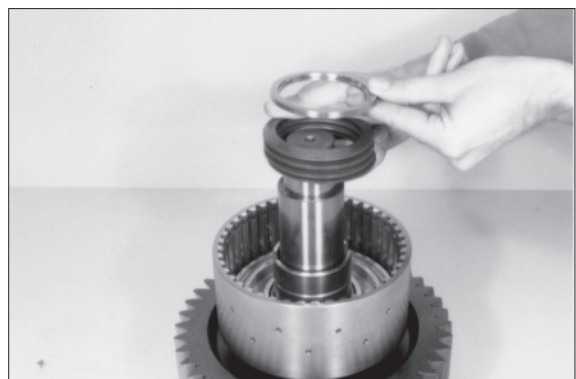

75773TM180

- ⑦ Preload cup spring pack and fix it by means of snap ring.
 Assembly aid 5870 345 088

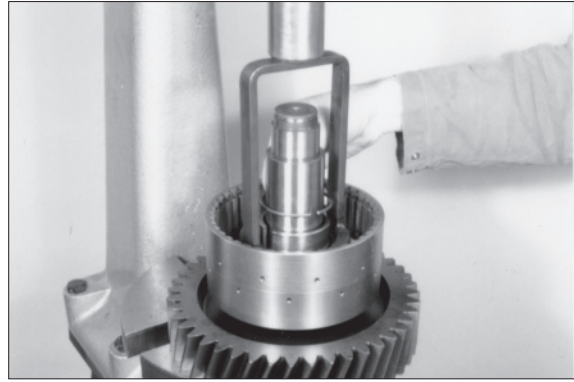

75773TM181

- ※ The plate arrangement of clutch K1 is identical with clutch K2 and K3.
 In this connection see the following drafts.

Plate pack K1

- 1 Plate carrier
 - 2 Piston
 - 3 Outer plate-one side coated (1 piece)
 - 4 Inner plates (9 pieces)
 - 5 Outer plates-on both sides coated (9 pieces)
 - 6 Snap ring (optional $s=2.1\sim 4.2$ mm)
 - 7 End shim
- Effective number of friction surfaces = 18

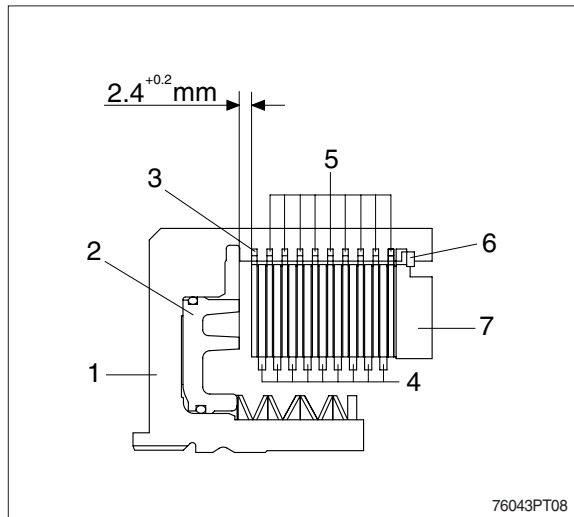

76043PT08

- ※ Install outer plate 3 with the uncoated side facing the piston.

Plate pack K2 and K3

- 1 Plate carrier
 - 2 Piston
 - 3 Outer plate-one side coated (1 piece)
 - 4 Inner plates (7 pieces)
 - 5 Outer plates-on both side coated (7 pieces)
 - 6 Snap ring (optional $s= 2.1\sim 4.2$ mm)
 - 7 End shim
- Effective number of friction surfaces = 14

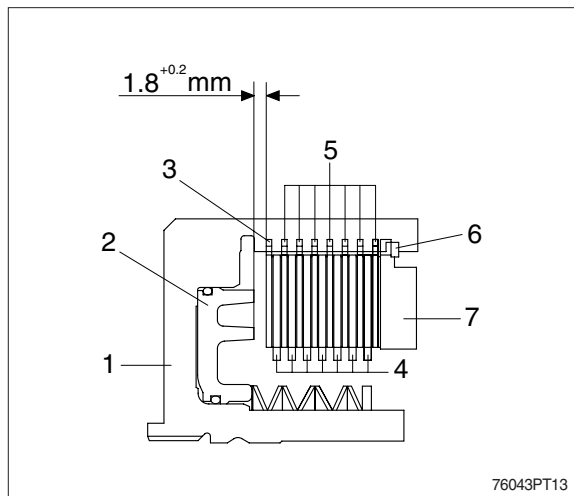

76043PT13

- ※ Install outer plate 3 with the uncoated side facing the piston.
 Install on the end-shim two outer and inner plates each.

Adjust plate clearance

Plate clearance clutch K1 $2.4^{+0.2}$ mm

Plate clearance clutch K2 and K3
 $1.8^{+0.2}$ mm

※ For the adjustment of the plate clearance are snap rings with different thickness available.

To ensure a faultless measuring result, install the plates for the moment without oil.

Introduce plate pack according to drafts / page 3-118.

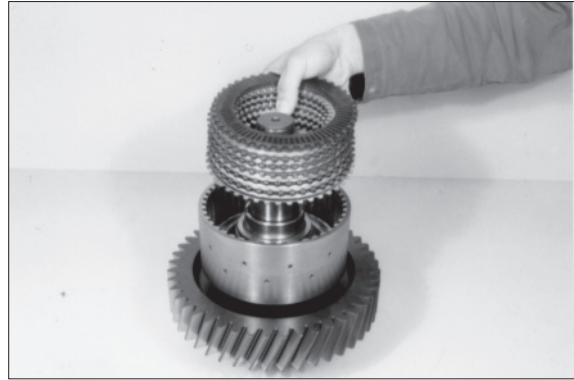

75773TM185

⑧ Lay on the end shim and squeeze circlip in (e.g. $s = 3.1$ mm).



75773TM186

⑨ Press on the end shim with about 100N (10 kg), apply dial indicator and set it at zero.

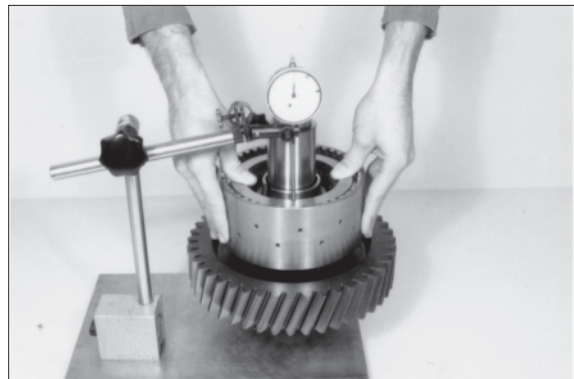

75773TM187

⑩ Now, push the end shim by means of screw driver against snap ring until contacts is obtained (upward) and read plate clearance on the dial indicator.

※ In case of a deviation from the required plate clearance, correct with corresponding snap ring ($s = 2.1 \sim 4.2 \text{ mm}$).

After the adjustment of the plate clearance has been carried out, remove the plate pack, oil plates and install it again.

Use oil SAE 10W-30/15W-40.

Magnetic stand 5870 200 055

Dial indicator 5870 200 057

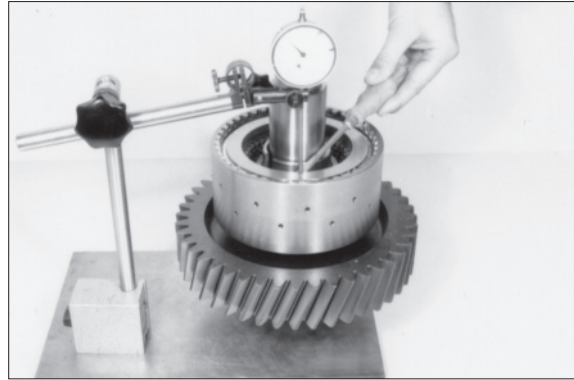

75773TM188

⑪ Assemble running disk 1 ($55 \times 78 \times 5$), axial needle cage 2 and axial washer 3 ($55 \times 78 \times 1$).

Install running disk 1, with the chamber facing the axial needle cage.

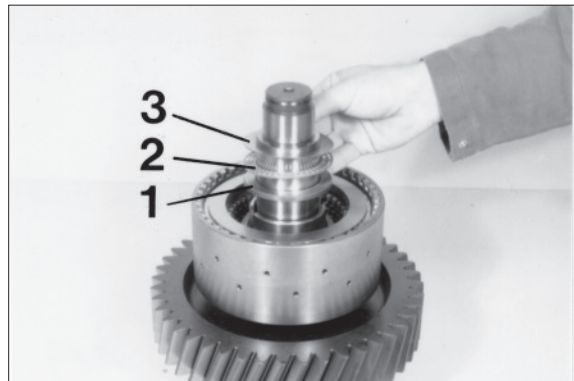

75773TM189

⑫ Assemble both needle bearings.

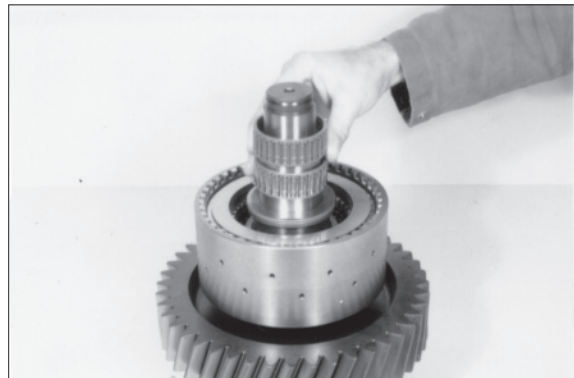

75773TM190

- ⑬ Introduce idler gear until all inner plates are accommodated.



75773TM191

- ⑭ Assemble axial washer 3 (55×78×1), axial needle cage 2 and running disk 1 (55×78×5).
- ※ Install running disk 1, with the chamfer facing the axle needle cage.
 - ※ Only if the running disk in overlapping with the shaft collar is ensured that all inner plates are accommodated.

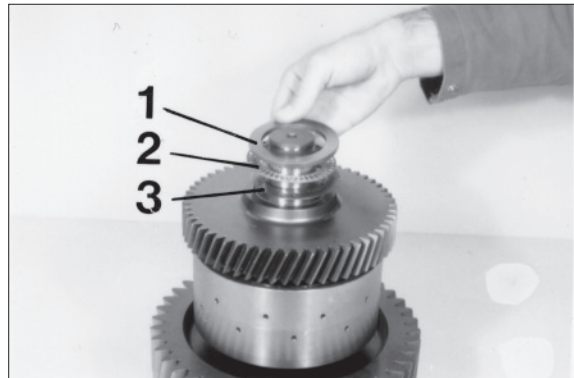

75773TM192

- ⑮ Press tapered roller bearing against shoulder.
Press opposite tapered roller bearing against shoulder.

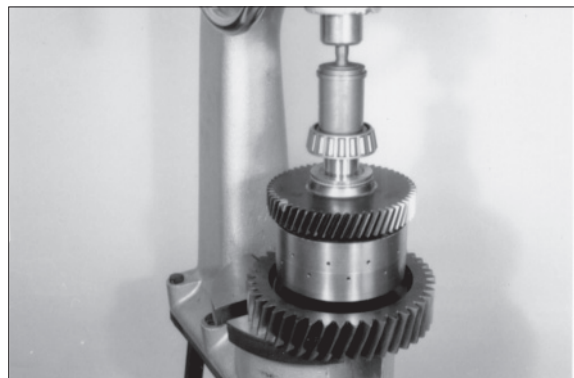

75773TM193

- ⑯ Check function of the clutch by means of compressed air.
- ※ At correctly installed components, the closing respectively opening of the clutch is clearly audible.

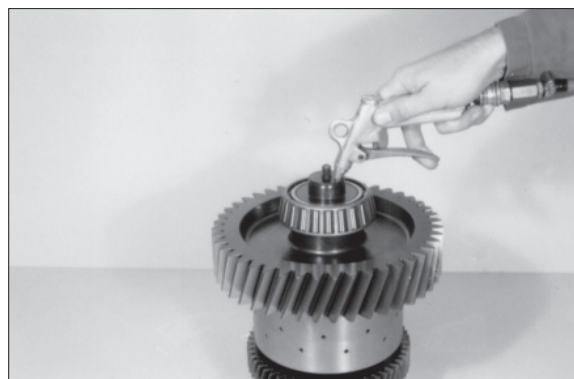

75773TM194

- ⑰ Squeeze rectangular ring in (arrow) and let it snap in.
Install opposite rectangular ring accordingly.



75773TM195

(4) Reassemble clutch K4

- ① Undercool shaft (about -80°C), heat gear (about $+120^{\circ}\text{C}$) and assemble it until contact is obtained.



75773TM200

- ② Fix gear axially by means of circlip.
Set of external pliers 5870 900 015

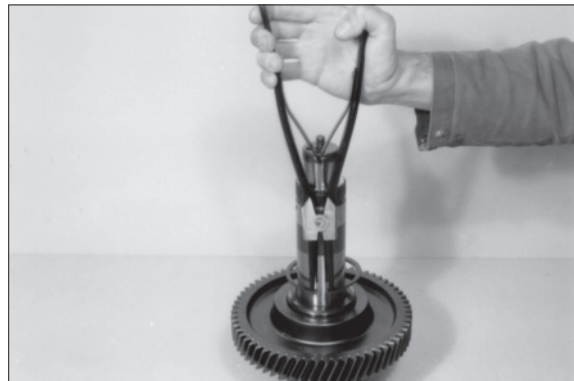

75773TM201

- ③ Install stud (arrow).
※ Wet screw-in thread with loctite (type No. 241).
• Torque limit (M10) : $1.7 \text{ kgf} \cdot \text{m}$ ($12.5 \text{ lbf} \cdot \text{ft}$)



75773TM202

- ④ Check function of the purge valve.
※ Ball must not stick, if necessary clean with compressed air.
Insert both O-ring (arrow) scrollfree into the grooves of the piston and oil them.

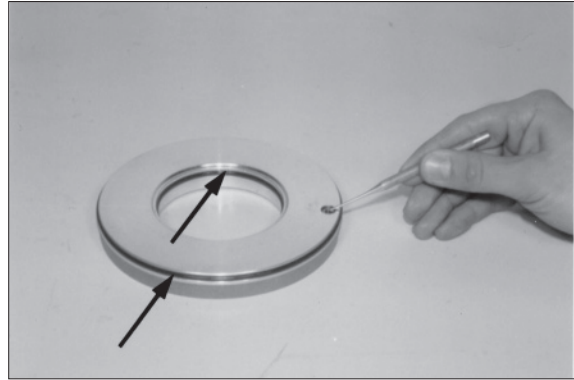

75773TM203

- ⑤ Introduce piston until contact is obtained.
※ Pay attention to the installation position, see figure.



75773TM204

- ⑥ Install cup-spring pack and guide ring.
※ Pay attention to the stacking of the cup springs, see draft, page 3-124.



75773TM205

- ⑦ Preload cup-spring pack and fix it by means of snap ring.
Assembly aid 5870 345 088



75773TM206

Plate pack K4

※ The following draft shows the installation position of the components.

- 1 Plate carrier
- 2 Piston
- 3 Outer plate-one side coated (1 piece)
- 4 Inner plates (5 pieces)
- 5 Outer plates-coated on both sides (5 pieces)
- 6 Snap ring (optional $s = 2.1\sim 4.2$ mm)
- 7 End shim

Effective number of friction surfaces = 10

※ Install outer plate 3 with the uncoated side facing the piston.

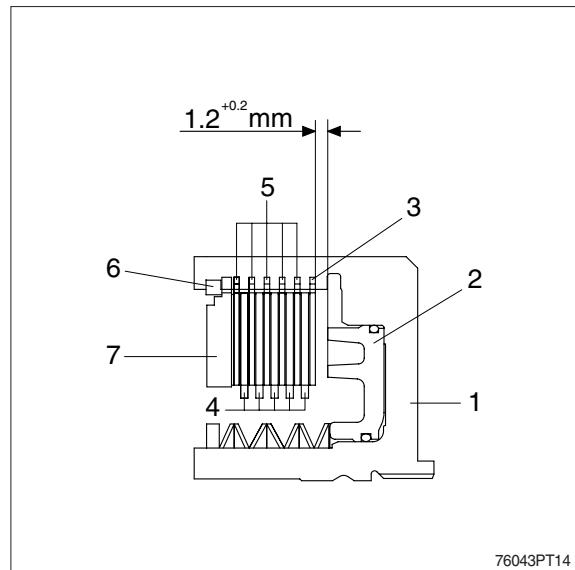

76043PT14

Adjust plate clearance = $1.2^{+0.2}$ mm

※ For the adjustment of the plate clearance are snap rings of different thickness available.

To ensure a faultless measuring result, install plates for the moment without oil.

⑧ Introduce plate pack according to the draft.



75773TM210

⑨ Lay on end shim and squeeze snap ring in (e.g. $s = 3.4$ mm).

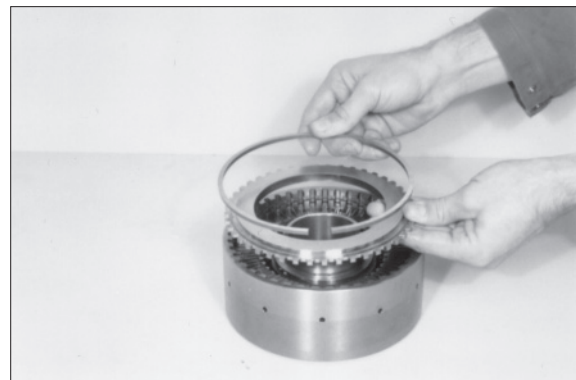

75773TM211

- ⑩ Press on the end shim with about 100N (10 kg), apply dial indicator and set it at zero.

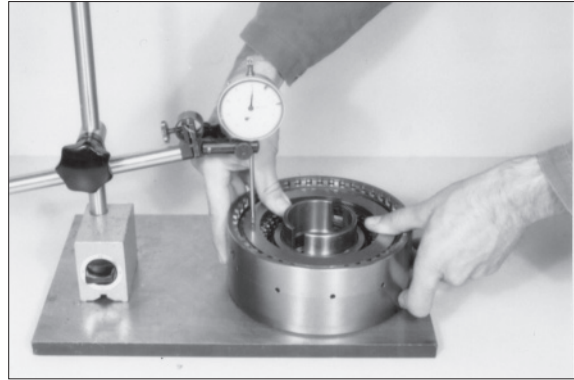

75773TM212

- ⑪ Now, push the end shim by means of screw driver against snap ring until contacts is obtained (upward) and read plate clearance on the dial indicator.

※ In case of a deviation from the required plate clearance, correct with corresponding snap ring (s=2.1~4.2 mm). After the adjustment of the plate clearance has been carried out, remove the plate pack, oil plates and install it again.

※ Use oil SAE 10W-30/15W-40.

Magnetic stand 5870 200 055
Dial indicator 5870 200 057

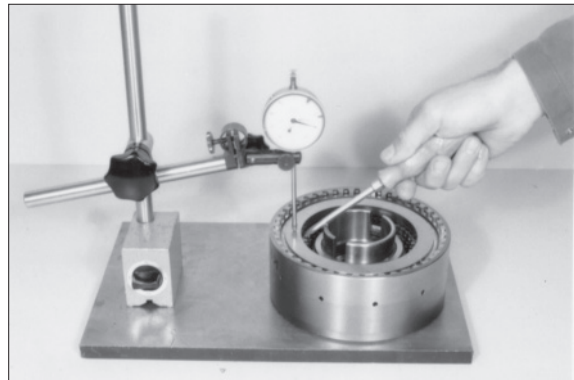

75773TM213

- ⑫ Introduce idler gear until all inner plates are accommodated.

※ This step makes the later assembling of the idler gear easier.

Now, remove idler gear again.



75773TM214

- ⑬ Assemble both axial washers as well as needle case.
※ Upper and lower axial washer have the same thickness (55×78×1).

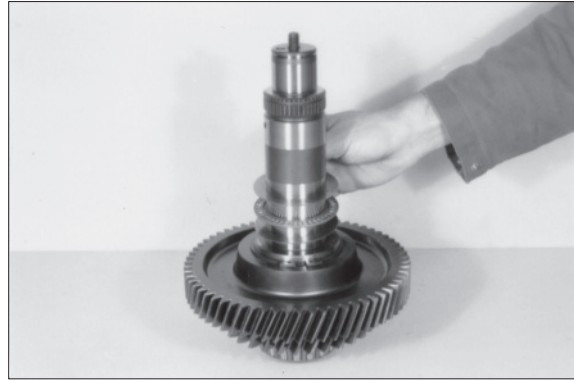

75773TM215

- ⑭ Assemble both needle bearings.



75773TM216

- ⑮ Assemble idler gear.



75773TM217

- ⑯ Assemble axial washer 3 (55×78×1), needle cage 2 and running disk 1 (55×78×5).
※ Install running disk 1, with the chamfer facing the needle cage.

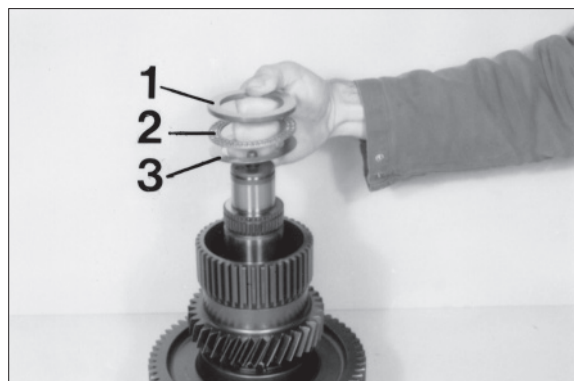

75773TM218

- ⑰ Heat inner diameter of the plate carrier (about 120°C).
Assemble preassembled plate carrier until all inner plates are accommodated.
* Use safety gloves.

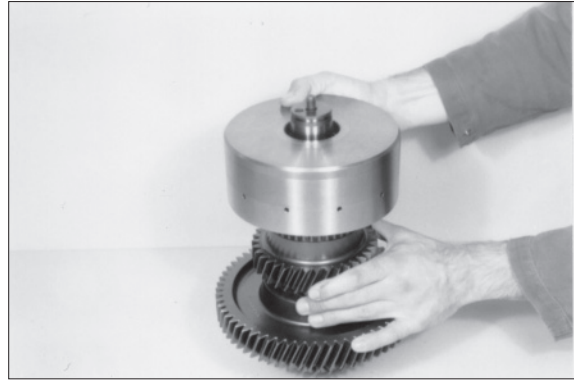

75773TM219

- ⑱ Fix plate carrier axially by means of circlip.
Set of external pliers 5870 900 015



75773TM220

- ⑲ Check function of the clutch by means of compressed air.
* At correctly installed components, the closing respectively opening of the clutch is clearly audible.



75773TM221

- ⑳ Press tapered roller bearing against shoulder.
Install opposite tapered roller bearing.

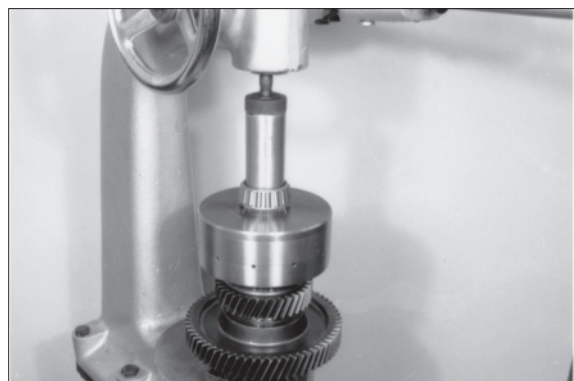

75773TM222

Squeeze rectangular ring in (arrow) and let it snap in.
Install opposite rectangular ring.



75773TM223

(5) Preassemble drive shaft

- ① Undercool the drive shaft (about -80°C), heat the gear (about $+120^{\circ}\text{C}$) and assemble it until contact is obtained.



75773TM225

- ② Fix gear axially by means of circlip.

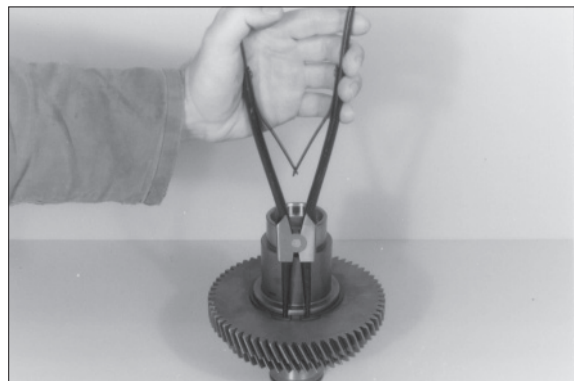

75773TM226

- ③ Squeeze snap ring into groove of the turbine shaft.

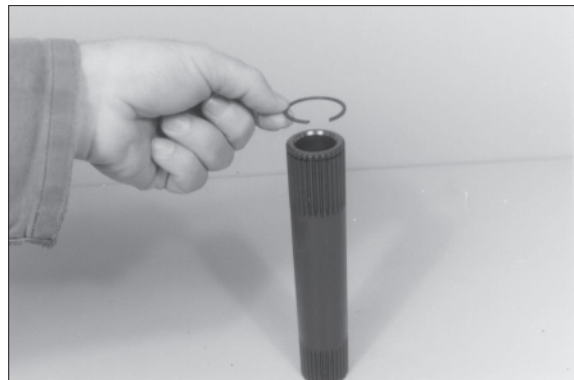

75773TM227

- ④ Introduce turbine shaft until the snap ring snaps into the groove of the drive shaft turbine shaft is axially fixed.



75773TM228

- ⑤ Press tapered roller bearing against shoulder.
Now, squeeze rectangular ring into the groove of the drive shaft and let it snap in.
Install opposite tapered roller bearing.

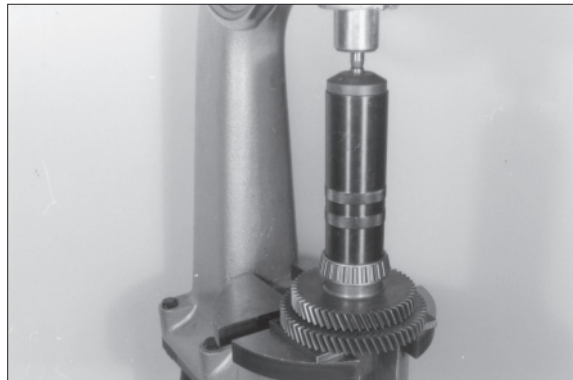

75773TM229

(6) Preassemble and install output

- ① Lay on screening plate



75773TM230

- ② Heat tapered roller bearing and assemble it until contact is obtained.
Install opposite tapered roller bearing accordingly.



75773TM231

③ Insert all bearing outer races into the bearing bores of the housing. Install O-ring (arrows).

※ At the use of already run bearings, pay attention to the allocation of the bearing outer races, see also note/page 3-100.

AN	Input
KV	Clutch-Forward
KR	Clutch-Reverse
K1	Clutch-1st speed
K2	Clutch-2nd speed
K3	Clutch-3rd speed
K4	Clutch-4th speed
AB	Output

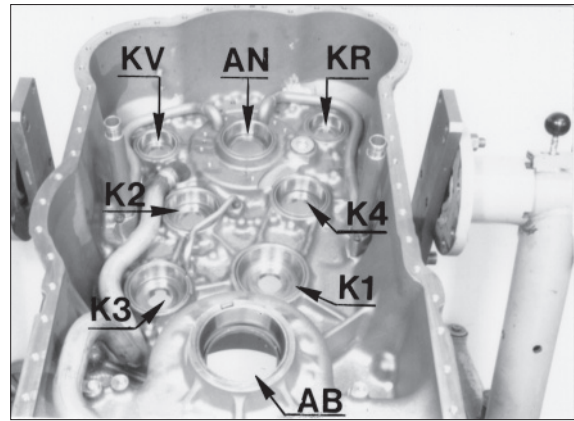

75773TM232

④ Lay on screening plate.

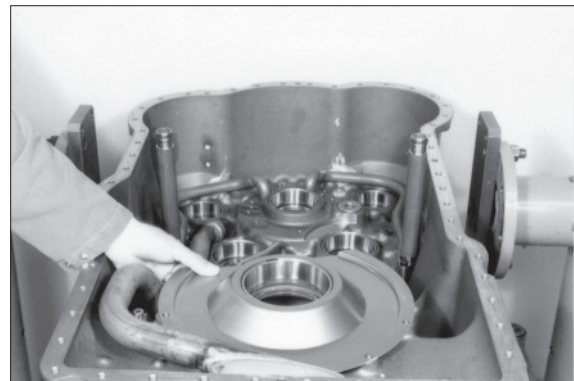

75773TM233

⑤ Insert preassembled output shaft. Fix screening plates by means of socket head screws.

- Torque limit (M8/8.8) : 2.3 kgf · m
(17.0 lbf · ft)



75773TM234

(7) Install preassembled drive shaft and clutches

- ① Insert all bearing outer races into the bearing bores of the housing cover.
- ※ At the use of already run bearings, pay attention to the allocation of the bearing outer races, see also note/page 3-100.

AN	Input
KV	Clutch-Forward
KR	Clutch-Reverse
K1	Clutch-1st speed
K2	Clutch-2nd speed
K3	Clutch-3rd speed
K4	Clutch-4th speed
AB	Output

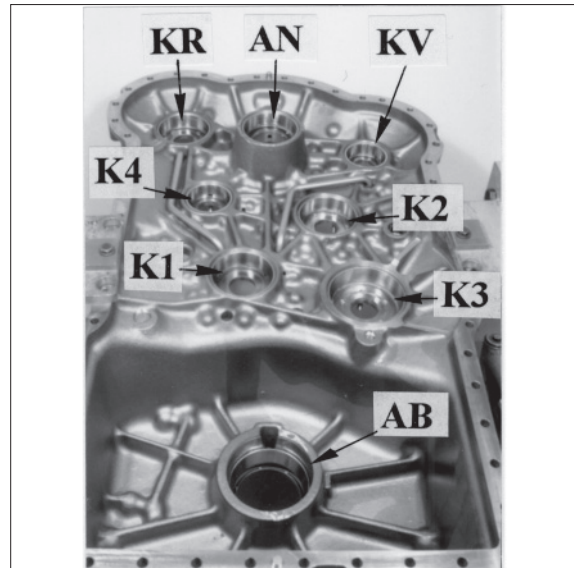

75773TM235

- ※ Prior to the installation of the clutches and the drive shaft, grease rectangular rings and align them centrally.
- ② Insert clutch KR, drive shaft and clutch KV together into the housing cover.



75773TM236

- ③ Lift drive gear and position clutch K4.



75773TM237

④ Install clutch K3.

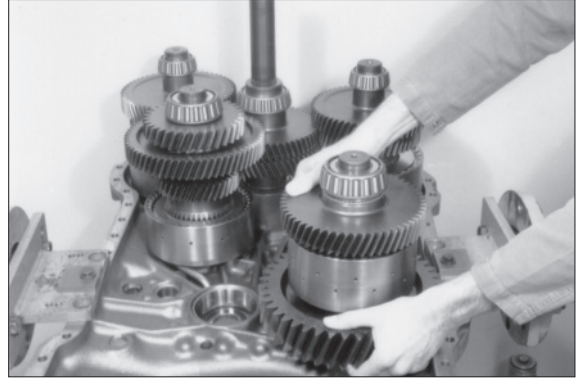

75773TM238

⑤ Position clutch K2.

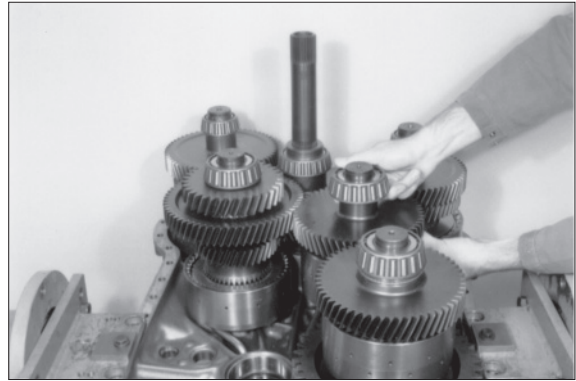

75773TM239

⑥ Lift clutch K4 and position clutch K1.



75773TM240

⑦ Illustration on the right shows the installation position of the single clutches in the housing cover. Grease rectangular rings (arrows) and align them centrally.

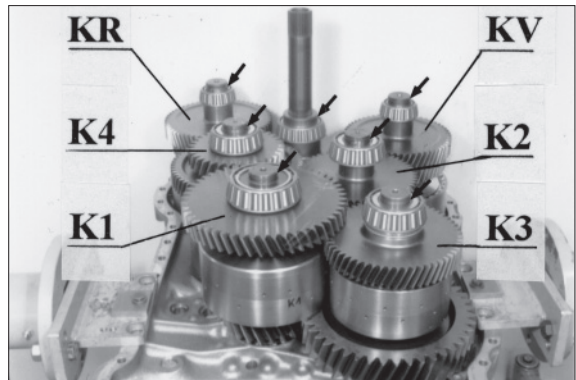

75773TM241

- ⑧ Fix all clutches by means of handles.
 Handle (6 pieces needed) 5870 260 010

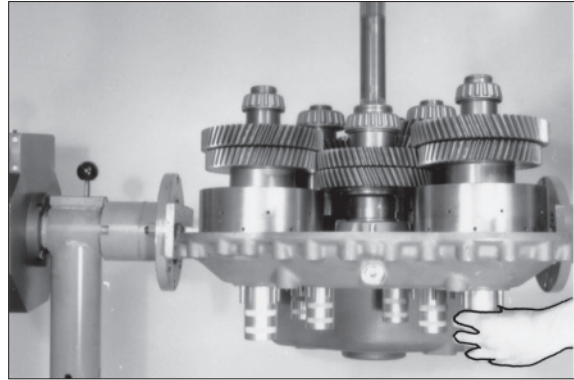

75773TM242

- ⑨ Tilt housing cover 180°.
 Install eye bolts (arrows).
 Eye bolt(M20, 2EA) 0636 804 003
 Eye bolt(M16, 1EA) 0636 804 001
 Puller device 5870 000 017

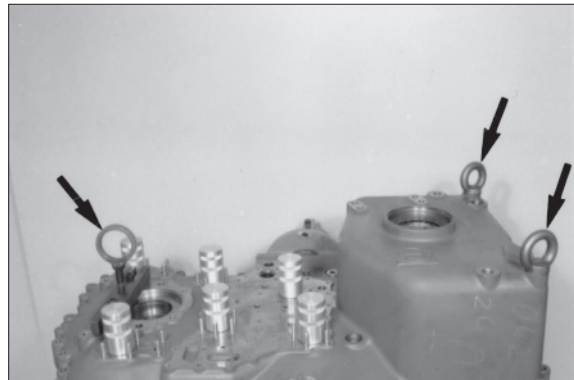

75773TM243

- ⑩ Grease O-rings of the two oil tubes.
 Wet mounting face with sealing compound loctite (type No.574).
 Position preassembled housing cover by means of lifting device carefully on the gearbox housing until contact is obtained.
 ※ Pay attention to the overlapping of the oil tubes with the bores in the housing cover.
 Lifting chain 5870 281 047



75773TM244

- ⑪ Remove handles again.

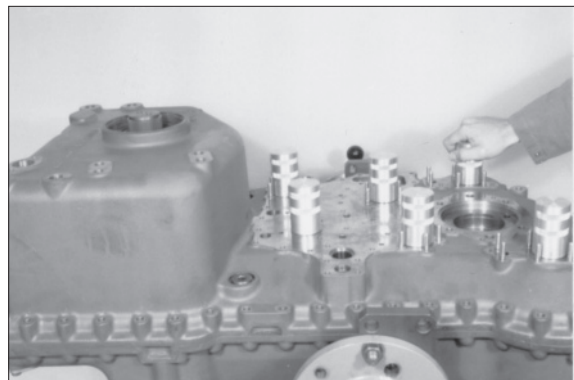

75773TM245

- ⑫ Install both cylindrical pins centrally to the housing face.

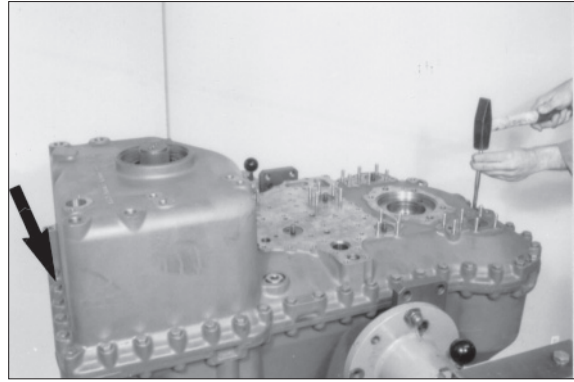

75773TM246

- ⑬ Fasten housing cover by means of hexagon head screws.
· Torque limit (M10/8.8) : 4.7 kgf · m
(33.9 lbf · ft)
※ Pay attention to position of the fixing plate, see Arrow.

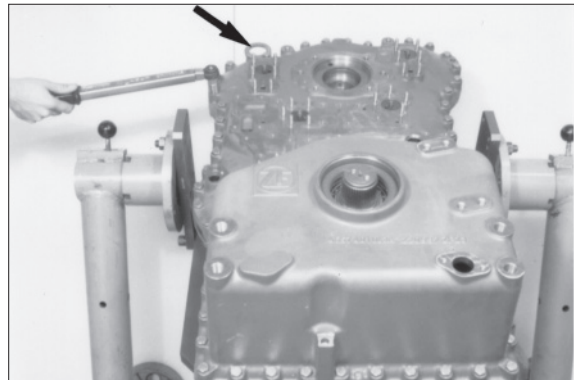

75773TM247

(8) Install pump shaft (power take off)

- ① Install ball bearing.
Squeeze rectangular ring in (arrow) and let it snap in.

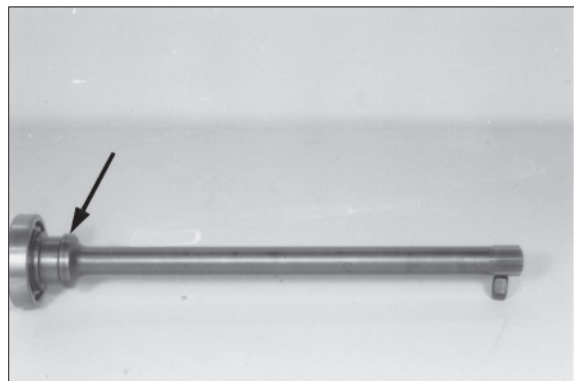

75773TM248

- ② Grease rectangular ring, align it centrally and introduce pump shaft until contact is obtained.

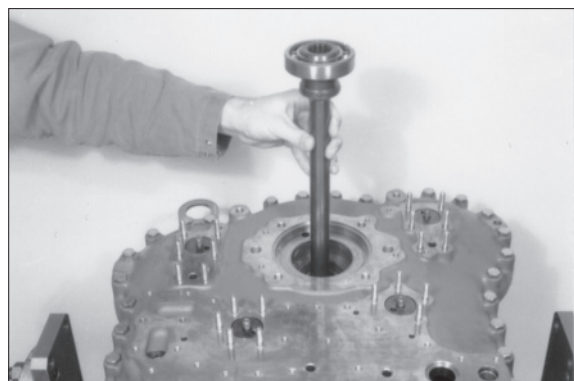

75773TM249

- ③ Fix pump shaft by means of circlip.

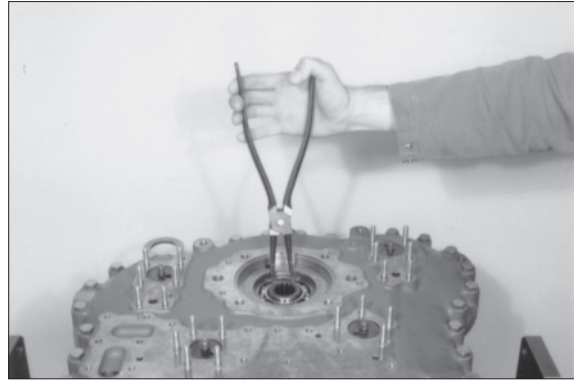

75773TM250

- ④ Insert O-ring (arrow) into the annular groove of the oil feed covers.

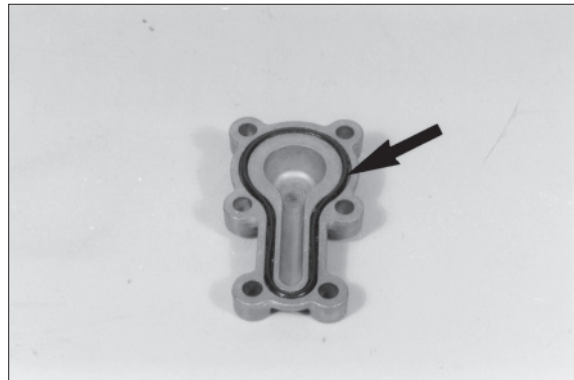

75773TM251

- ⑤ Fasten both covers (arrows) by means of hexagon nuts (use plain washers).
· Torque limit : 2.3 kgf · m (17.0 lbf · ft)

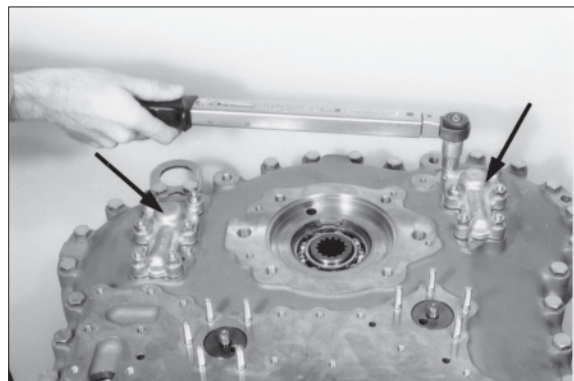

75773TM252

(9) Install output flanges

- ① Install shaft seal with the sealing lip facing the oil chamber.
※ At the use of the prescribed driver, the exact installation position is obtained.
Wet rubber coated outer diameter with spirit.
Grease sealing lip.
Driver 5870 048 213



75773TM255

- ② Assemble output flange.
Insert O-ring (arrow) into the gap of drive flange and shaft.

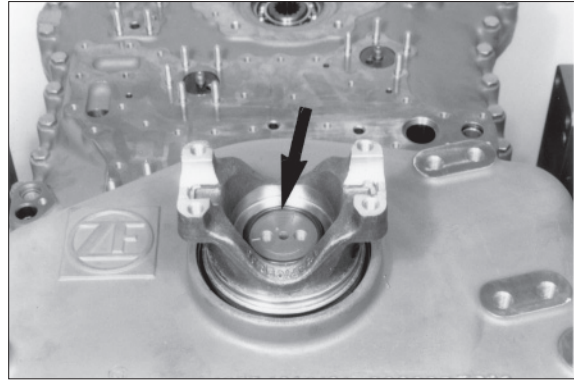

75773TM256

- ③ Fasten output flange by means of disk and hexagon head screws.
· Torque limit (M10/8.8) : 4.7 kgf · m
(33.9 lbf · ft)

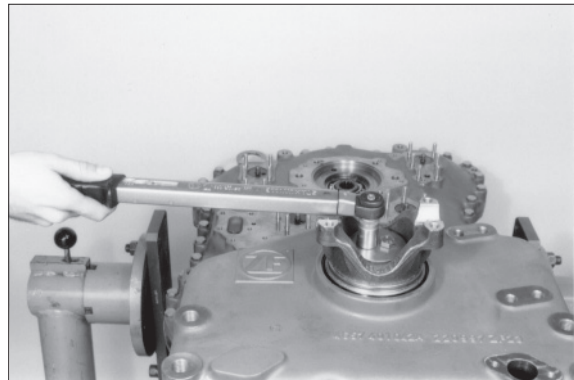

75773TM257

- ④ Fix hexagon head screws by means of lock plate.
Driver 5870 057 009
Handle 5870 260 002
Install converter side output flange accordingly.

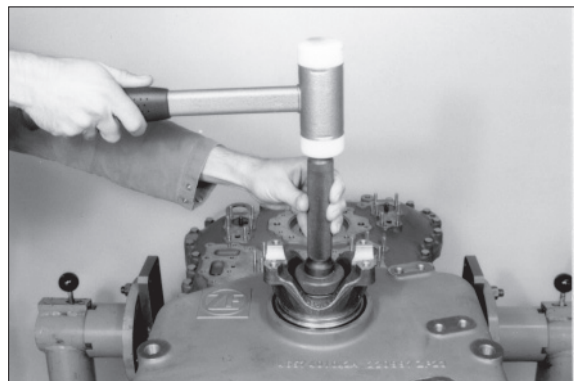

75773TM258

(10) Converter back pressure valve

- ① Illustration on the right shows the components of the converter back pressure valve.
- 1 Piston
 - 2 Compression spring
 - 3 Pressure plate
 - 4 Lock plate
- ※ Install pressure plate with the spigot (∅ 6 mm) facing the lock plate.

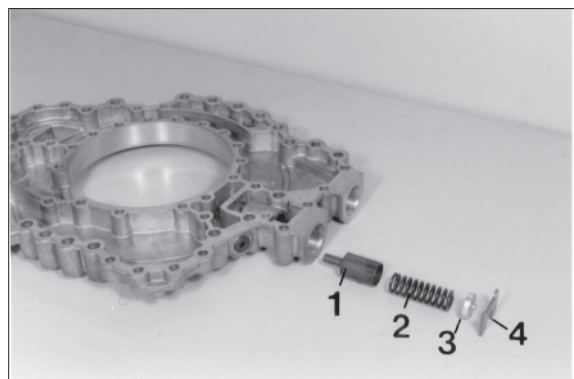

75773TM260

- ② Introduce components according to figure (10) ①, preload and fix by means of lock plate.

Equip plug (arrow) with new O-ring and install it.

- Torque limit(M14 × 1.5) : 2.5 kgf · m
(18.4 lbf · ft)

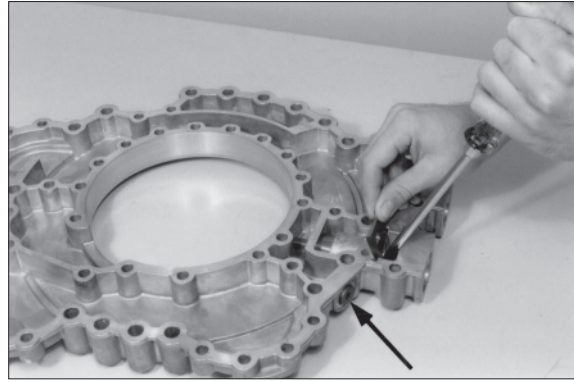

75773TM261

(11) Oil feed housing-Transmission pump

- ① Install two adjusting screws (arrows) and lay on gasket.

Adjusting screws (M8) 5870 204 011

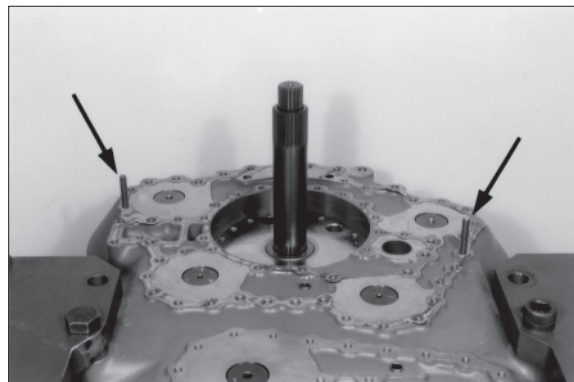

75773TM262

- ② Lay on oil feed housing and fix it provisionally by means of socket head screws.

- ※ Screw socket head screws only in until contact is obtained do not tighten.

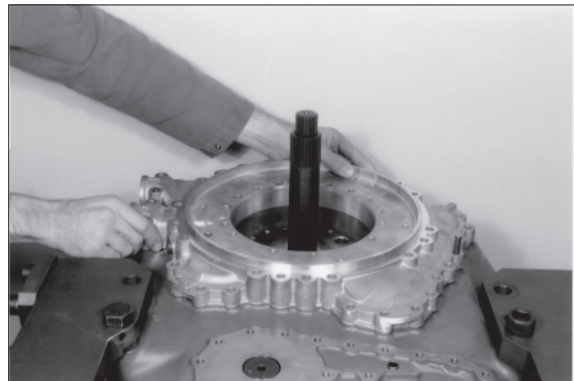

75773TM263

- ③ Install two adjusting screws and introduce stator shaft until contact is obtained.

- ※ Pay attention to the overlapping of the bores.

Adjusting screws (M10) 5870 204 007

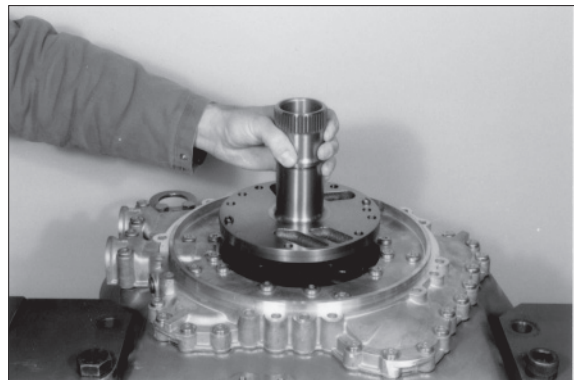

75773TM264

- ④ Insert O-ring (arrow) into the annular groove and oil it.



75773TM265

- ⑤ Introduce transmission pump (complete) and put it by means of socket head screws (for the moment without O-rings) evenly against shoulder.
Now, remove socket head screws again.

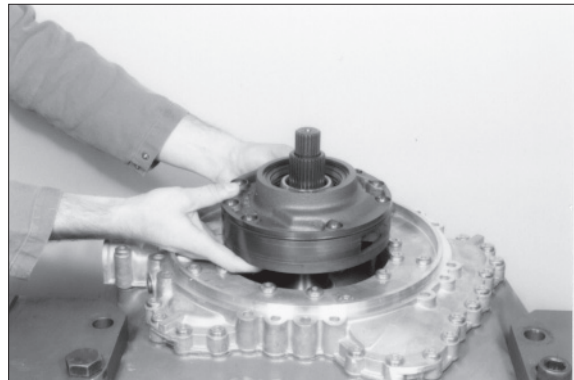

75773TM266

- ⑥ Equip socket head screws with new O-ring (arrow).
※ Grease O-rings.

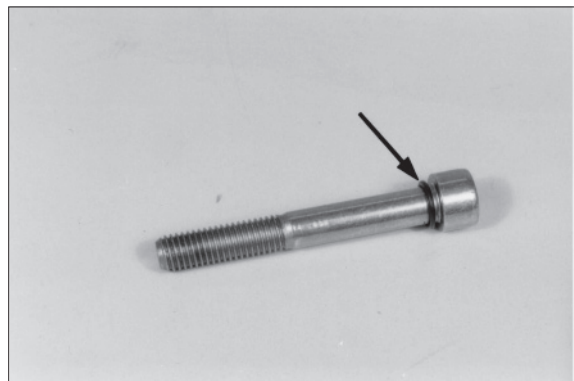

75773TM267

- ⑦ Fasten transmission pump by means of socket head screws.
· Torque limit : 4.7 kgf · m (33.9 lbf · ft)

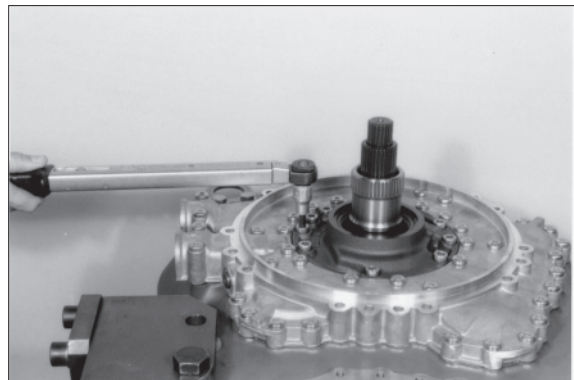

75773TM268

- ⑧ Fasten oil feed housing by means of socket head screws and hexagon head screws (2 pieces).

- Torque limit

- Socket head screw : 2.3 kgf · m (16.6 lbf · ft)

- Hexagon head screw : 4.7 kgf · m (33.9 lbf · ft)

- ※ Pay attention to the position of the fixing plate, see arrow.

Box spanner (Torx, TX-40) 5873 042 004

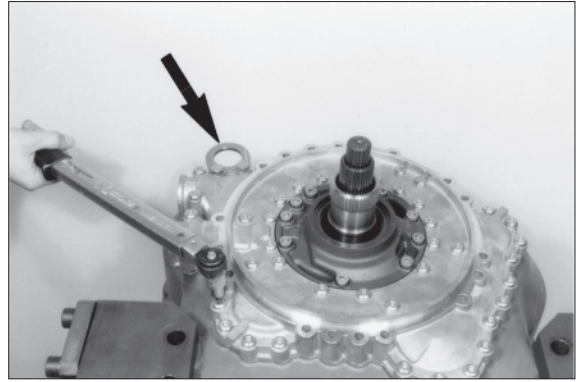

75773TM269

(12) Engine connection-Converter

- ① Fasten converter bell by means of hexagon head screws.

- Torque limit (M10/10.9) : 6.9 kgf · m

- (50.1 lbf · ft)

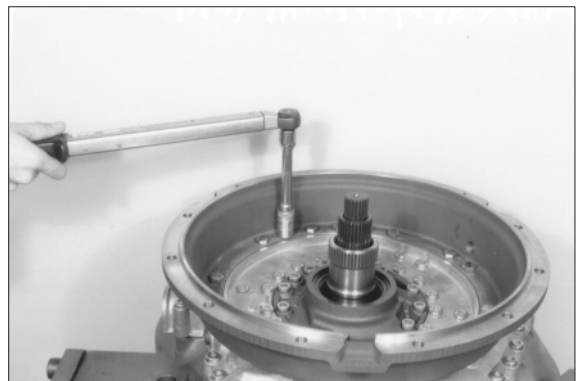

75773TM270

- ② Screw drive shaft and diaphragm together.

- Torque limit (M12/10.9) : 11.7 kgf · m

- (84.8 lbf · ft)

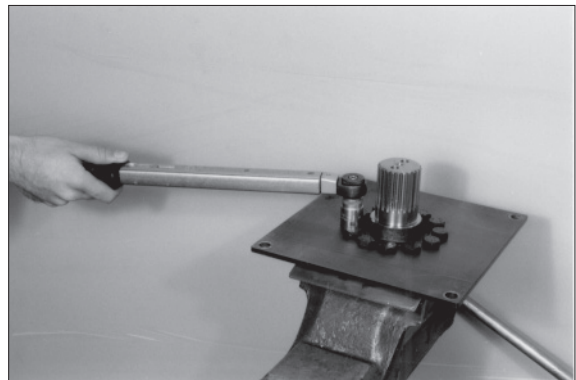

75773TM271

- ③ Fasten diaphragm by means of hexagon head screws on the converter.

- Torque limit (M12/10.9) : 11.7 kgf · m

- (84.8 lbf · ft)

- ※ Insert hexagon head screws with loctite (type No.262).

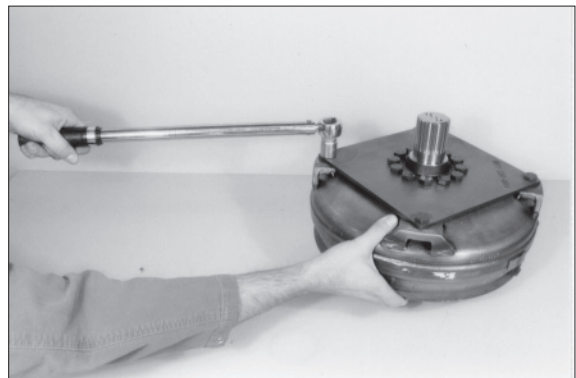

75773TM272

④ Introduce converter until contact is obtained.

- ※ Pulse disk of the converter must be positioned centrally to the bore of the inductive transmitter, see Arrow. Only in this way will be ensured that the converter is perfectly introduced.

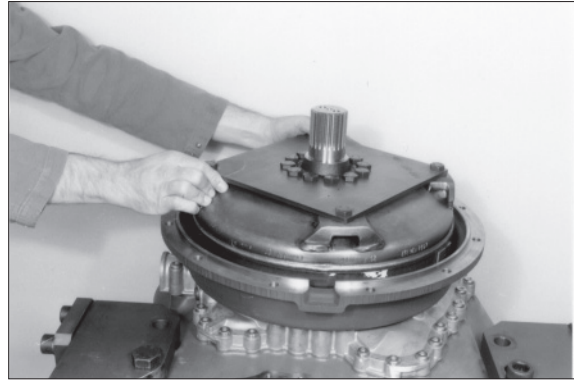

75773TM273

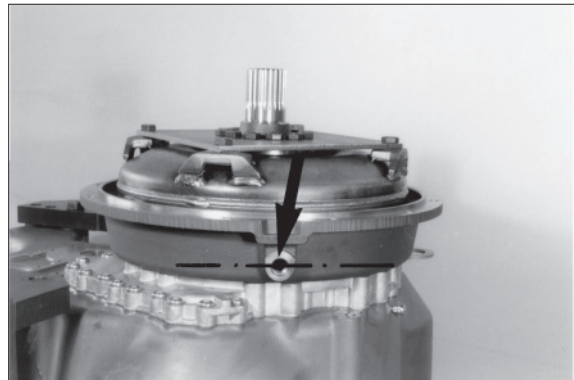

75773TM274

⑤ Insert ball bearing until contact is obtained and fix it by means of circlip.



75773TM275

⑥ Assemble housing cover.

Install drive flange, lay on disk an pull cover by means of hexagon head screws evenly against shoulder.

- Torque limit (M8/10.9) : 3.5 kgf · m
(25.1 lbf · ft)

- ※ Pay attention to the radial installation position of the cover, see figure.

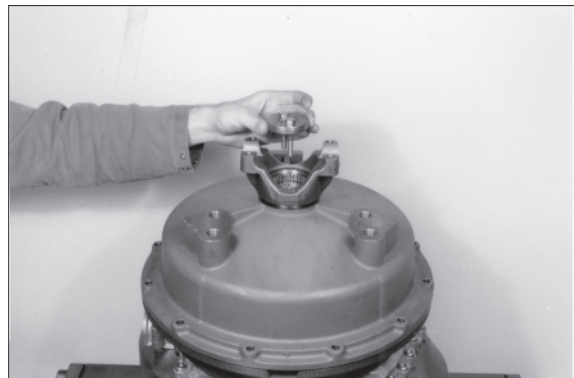

75773TM276

- ⑦ Fix hexagon head screws by means of lock plate.

Driver 5870 057 010

Handle 5870 260 002

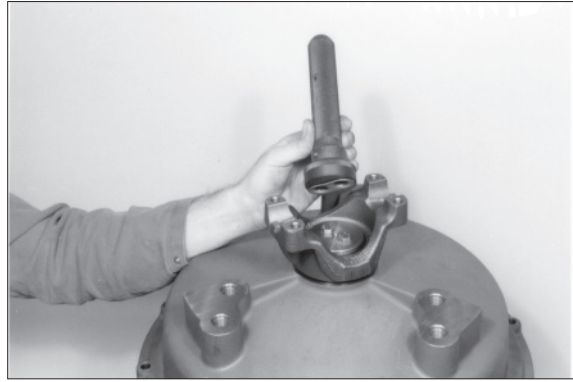

75773TM277

- ⑧ Fasten cover by means of hexagon head screws and nuts on the converter bell.

· Torque limit (M10/838) : 4.7 kgf · m
(33.9 lbf · ft)

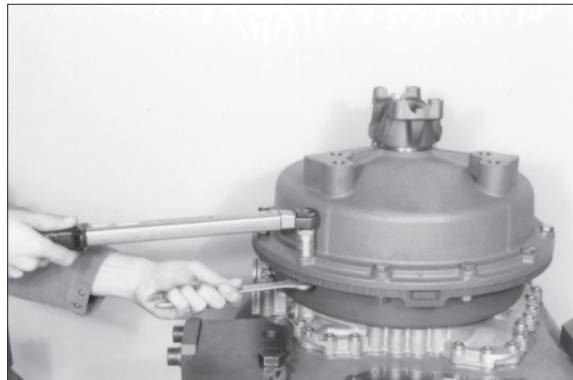

75773TM278

- ⑨ Mount gasket and fasten cover by means of hexagon head screws.

· Torque limit (M8/8.8) : 2.3 kgf · m
(17.0 lbf · ft)

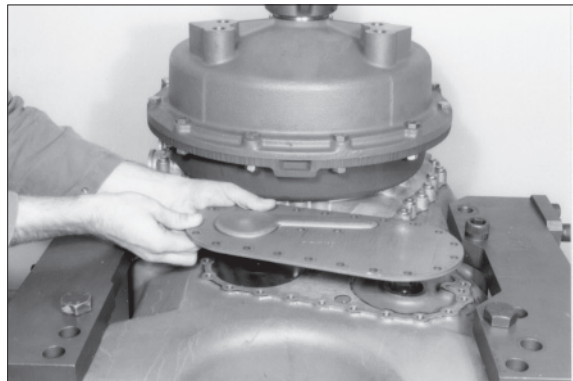

75773TM279

(13) Converter safety valve

- ① Insert converter safety valve (complete) into the housing hose.



75773TM280

(14) Mount duct plate and hydraulic control unit

① Install components according to the following draft.

· Torque limit (M8) : 2.3 kgf · m (17.0 lbf · ft)

※ Pay attention to the installation position of the different gaskets, see draft.

- 1 Gasket
- 2 Duct plate
- 3 Gasket
- 4 Intermediate plate
- 5 Gasket

Adjusting screws 5870 204 063
Box spanne 5873 042 004

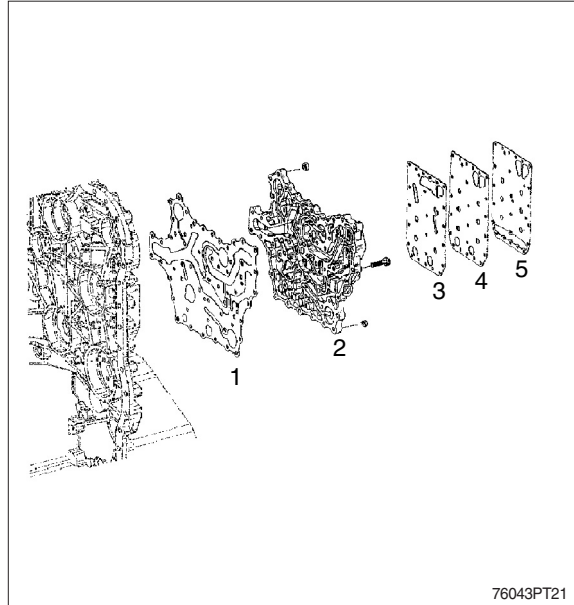

② Equip screw plug (arrow) with new O-ring and install it.

· Torque limit (M16 × 1.5) : 3.0 kgf · m
(21.7 lbf · ft)

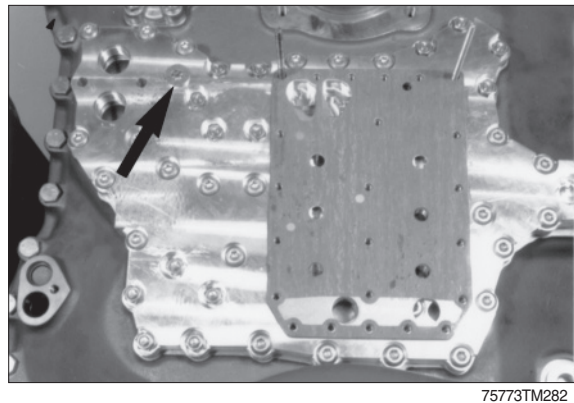

③ Fasten hydraulic control unit (HSG-94) by means of socket head screws.

· Torque limit (M6) : 0.97 kgf · m (7.0 lbf · ft)

Adjusting screws 5870 204 063
Box spanner (Torx Tx-27) 5873 042 002

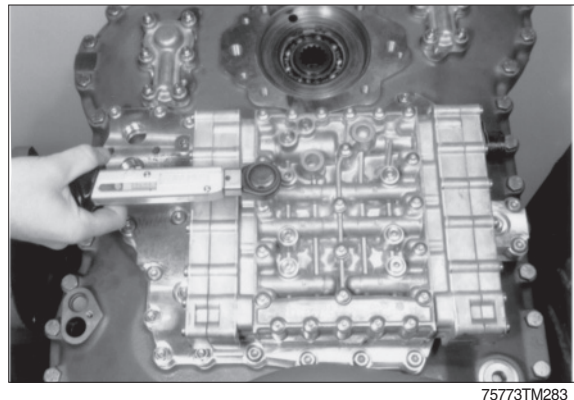

(15) Install plugs and oil level tube

① Equip both plugs (arrows) with new O-rings and install them.

- Torque limit (M18 × 1.5) : 5.1 kgf · m
(36.9 lbf · ft)
- Torque limit (M26 × 1.5) : 8.2 kgf · m
(59.0 lbf · ft)

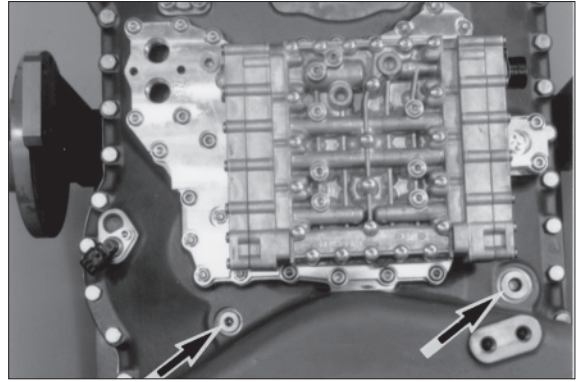

75773TM284

② Install oil level tube (arrow).

※ Mount new gasket.

- Torque limit (M8/10.9) : 3.5 kgf · m
(25.1 lbf · ft)

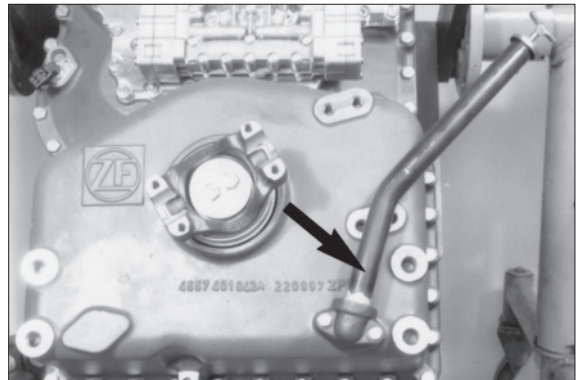

75773TM285

③ Install cover plate (arrow 1).

※ Install new gasket.

- Torque limit (M8/8.8) : 2.3 kgf · m
(17.0 lbf · ft)

Equip screw plug (arrow 2) with new O-ring and install it.

- Torque limit (M38 × 1.5) : 14.3 kgf · m
(103 lbf · ft)

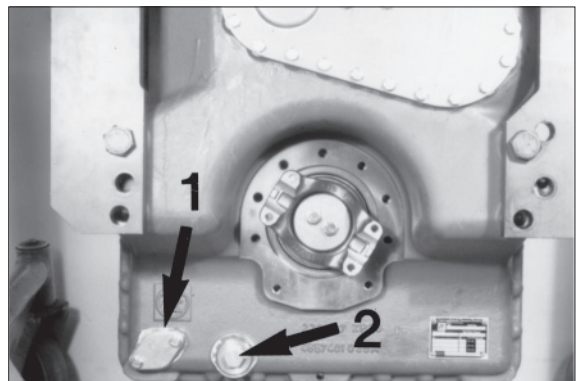

75773TM286

(16) Speed sensor and inductive transmitters

① The figures show the installation position of the single inductive transmitters and the speed sensor.

- 34 Speed sensor
n-Output and speedometer
- 21 Inductive transmitter
n-Turbine
- 47 Inductive transmitter
n-Central gear train
- 48 Inductive transmitter
n-Engine

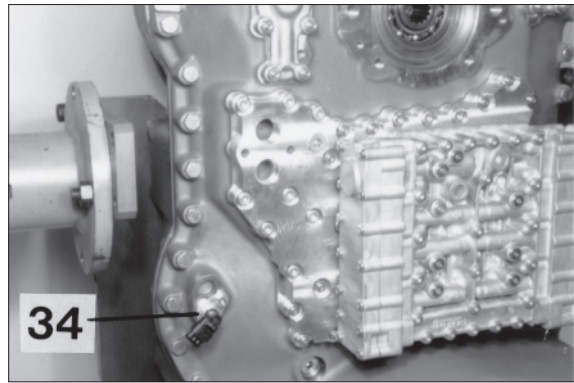

75773TM290

② Grease O-rings and install speed sensor as well as inductive transmitters.

- Torque limit : 2.3 kgf · m (17.0 lbf · ft)
(Socket head screw/Speed sensor)
- Torque limit : 3.1 kgf · m (22.1 lbf · ft)
(Inductive transmitter)

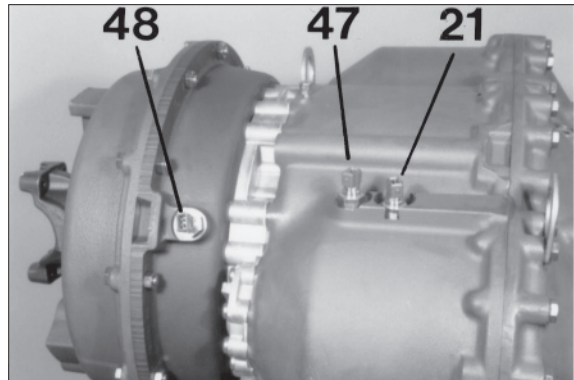

75773TM291

③ Install breather (arrow).

- Torque limit : 1.2 kgf · m (8.9 lbf · ft)

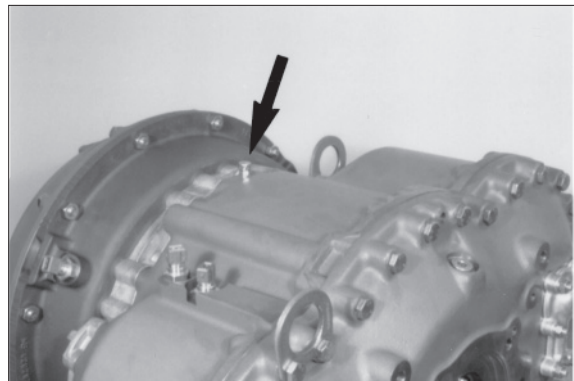

75773TM292

3. ZF AXLE

· FRONT AXLE

2) DISASSEMBLY OF OUTPUT AND BRAKE

(1) Fasten axle on assembly truck.

※ Special tool

Assembly truck 5870 350 000

Holding fixtures 5870 350 077

Clamps 5870 350 075

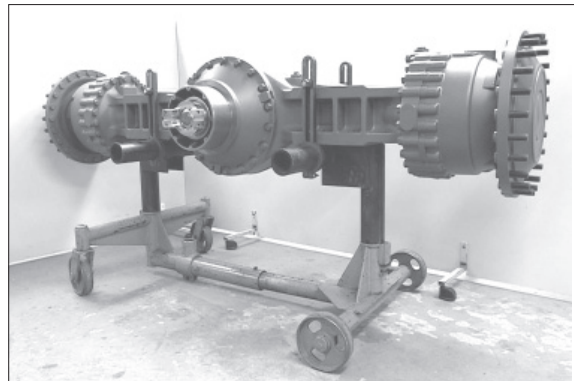

7577AAXF001

(2) Loosen screw plugs (3EA, see Figure 7577AAXF002 and 003) and drain oil from axle casing.

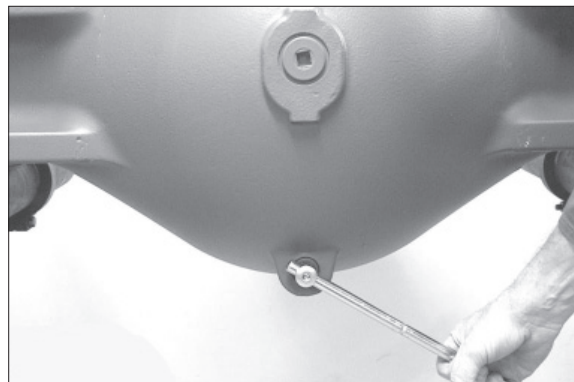

7577AAXF002

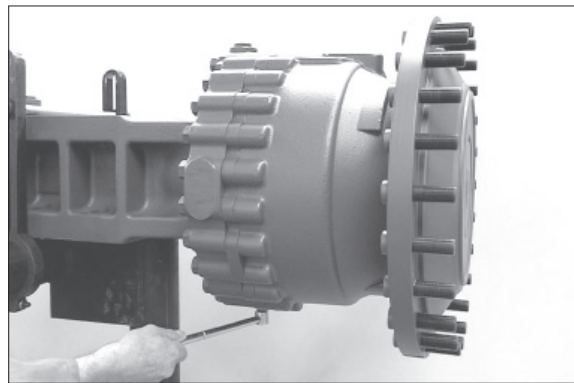

7577AAXF003

(3) Press off cover from the output shaft.

※ Special tool

Pry bar set 5870 345 065

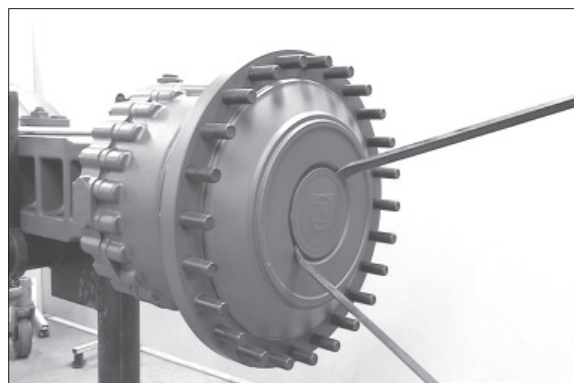

7577AAXF004

(4) Pull slotted pin by means of the striker out of the bore in the slotted nut.

- ※ Special tool
Striker 5870 650 001

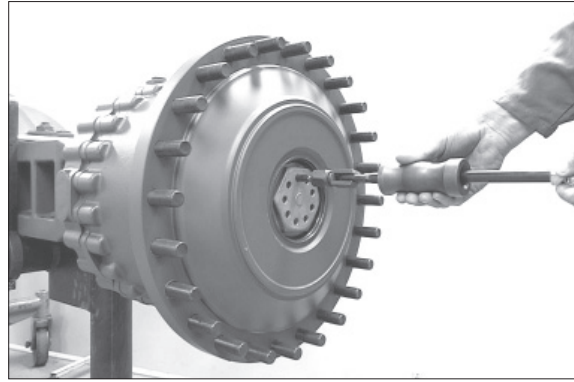

7577AAXF005

(5) Loosen slotted nut.

- ※ Special tool
Socket spanner 5870 656 078
Centering bracket 5870 912 028

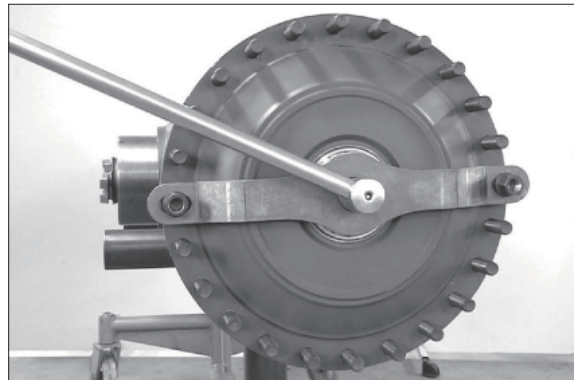

7577AAXF006

(6) Secure output by means of lifting tackle and loosen hexagon screws.

- ※ Special tool
Lifting bracket 5870 281 043

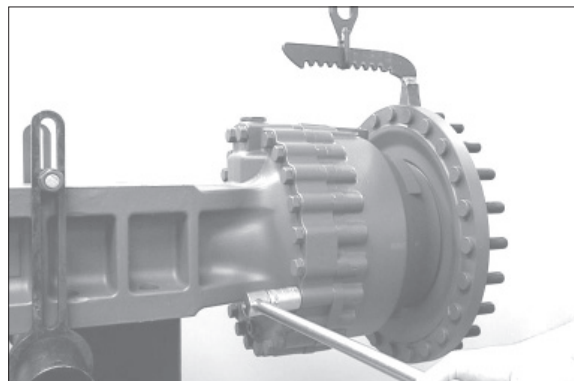

7577AAXF007

(7) Separate complete output from the axle casing.

- ※ Pay attention to released O-ring (see arrow).

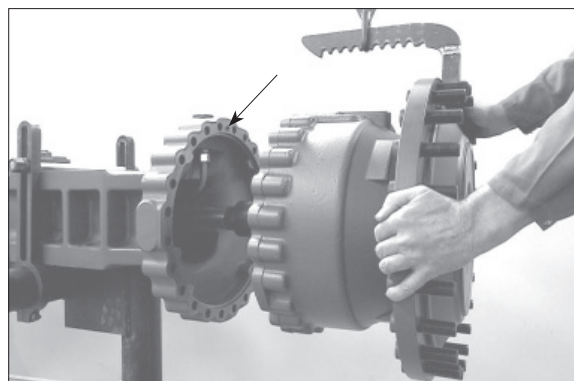

7577AAXF008

- (8) Pull stub shaft out of the sun gear shaft.
※ Pay attention to possibly released shim (s).

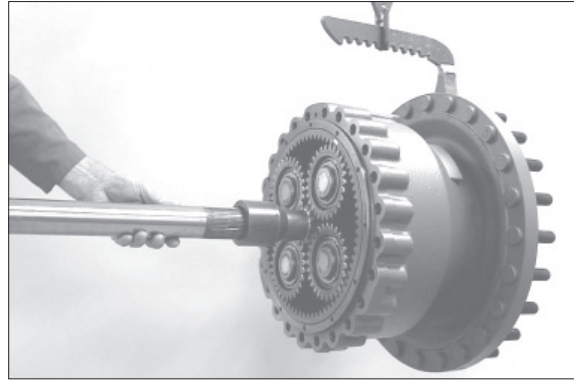

7577AAXF009

- (9) Remove shim (s) from the sun gear shaft.



7577AAXF010

- (10) Pull sun gear shaft out of the planet gears.

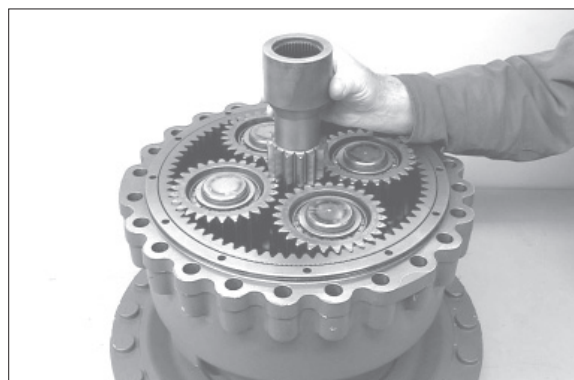

7577AAXF011

- (11) Lift planet carrier out of the brake housing.

- ※ Special tool
Internal extractor 5870 300 019



7577AAXF012

(12) Squeeze out the retaining ring.

- ※ Special tool
Set of external pliers 5870 900 015

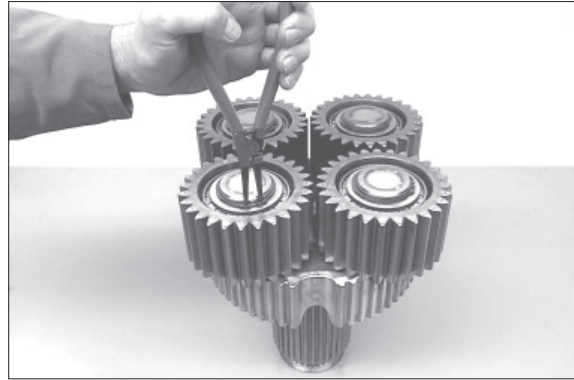

7577AAXF013

(13) Pull off the planet gear and remove the released bearing inner ring.

- ※ Special tool
Three-armed puller 5873 971 002



7577AAXF014

(14) Pull off the bearing inner ring.

- ※ Special tool
Gripping insert 5873 001 020
Basic set 5873 001 000

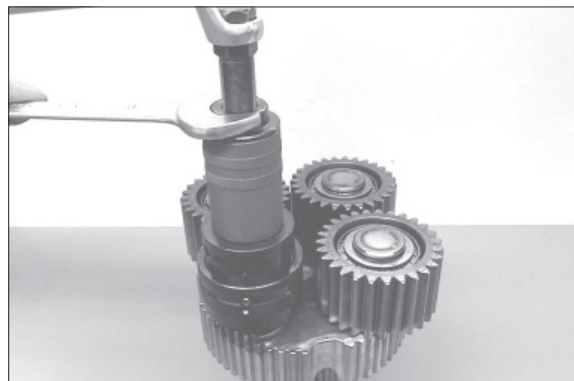

7577AAXF015

(15) Separate ring gear from the brake housing by means of two-armed puller.

- ※ Special tool
Two-armed puller 5870 970 007

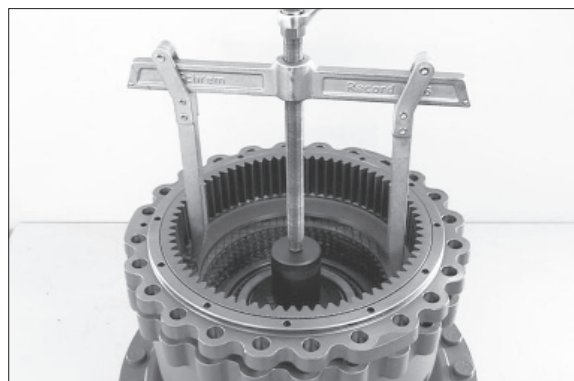

7577AAXF016

(16) Remove O-rings (see arrows) from the annular grooves of the ring gear.

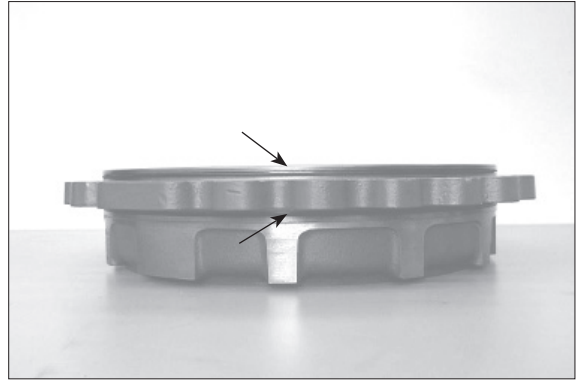

7577AAXF017

(17) Remove O-ring (see arrow) from the recess of the brake housing.

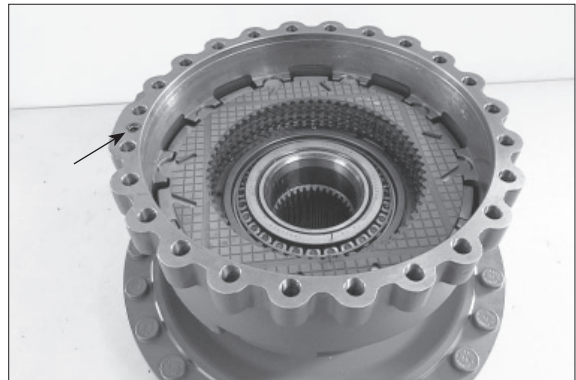

7577AAXF018

(18) Take the disc pack out of the brake housing.

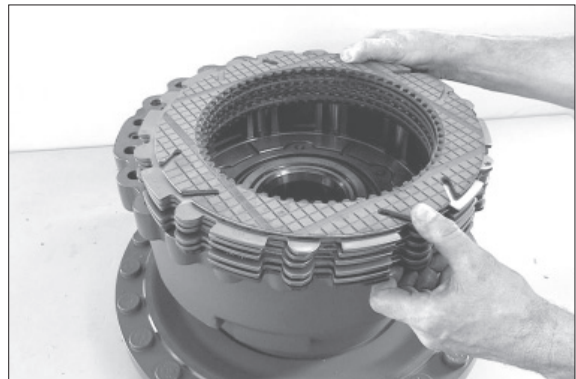

7577AAXF019

(19) Install slotted pins (6EA) in the support shim until they are flush-mounted.

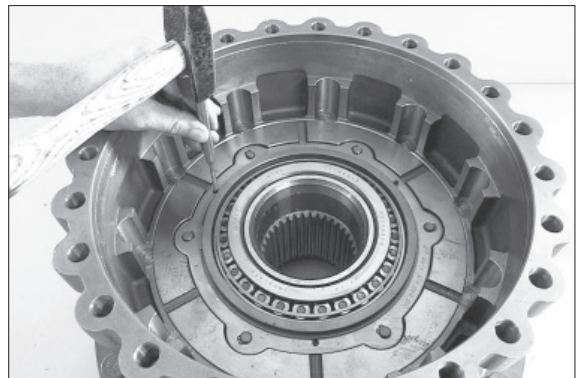

7577AAXF020

(20) Squeeze out the circlip.

※ Special tool

Set of external pliers

5870 900 016

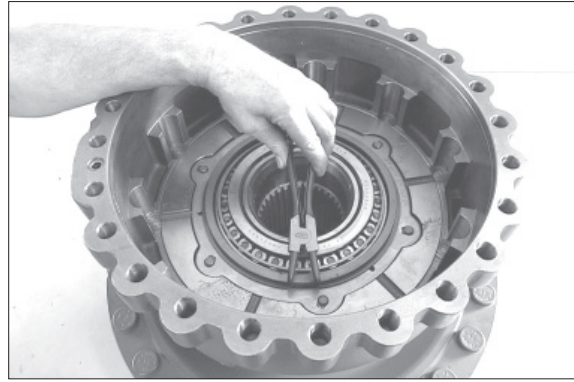

7577AAXF021

(21) Press piston out of the brake housing by means of compressed air.

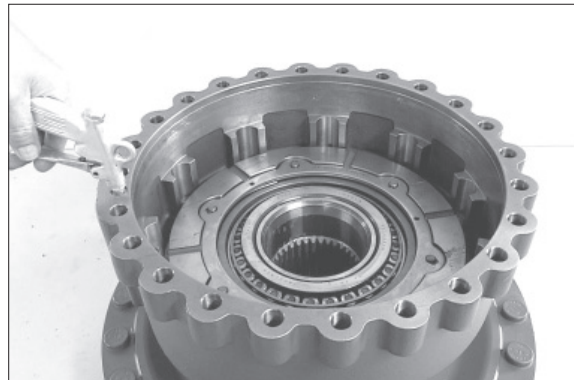

7577AAXF022

(22) Press support shim out of the piston by means of the automatic piston adjusting.

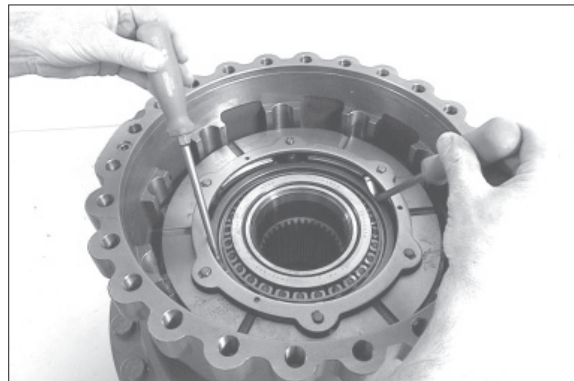

7577AAXF023

(23) Drive slotted pins (6EA) out of the support shim.

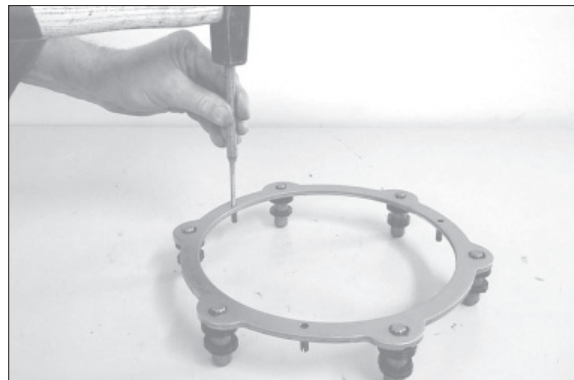

7577AAXF024

(24) Preload cup springs by means of a press and squeeze out the circlip.

※ Special tool

Assembly pliers 5870 900 051

Assembly fixture 5870 345 096

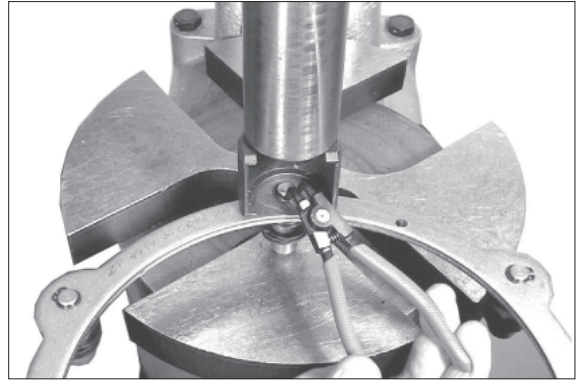

7577AAXF025

(25) Pull pin out of the support shim and remove released cup springs.



7577AAXF026

(26) Press gripping rings from the pin.

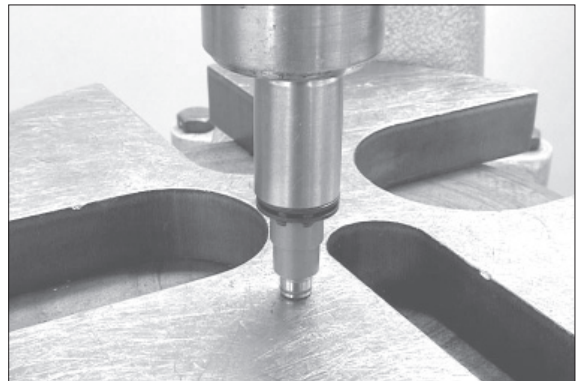

7577AAXF027

(27) Lift piston out of the brake housing.

※ Special tool

Adjusting device 5870 400 001

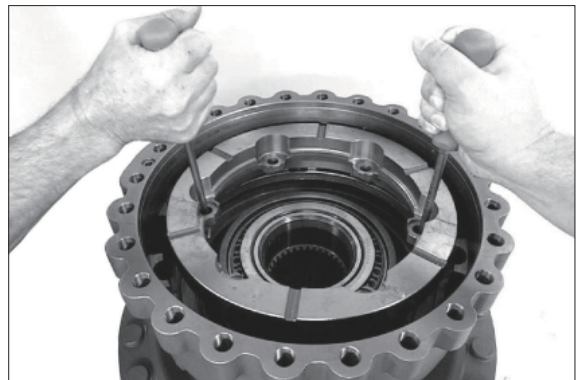

7577AAXF028

(28) Remove guide ring, support rings and U-rings from the annular grooves of the brake housing.

※ See below sketch for installation position of the single parts.

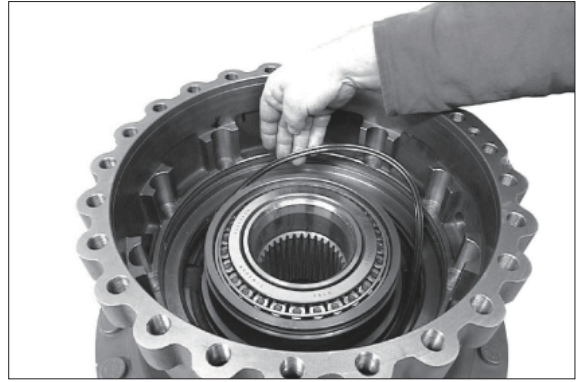

7577AAXF029

To the sketch :

- 1 Brake housing
- 2 Guide ring
- 3 Support ring
- 4 U-ring
- 5 U-ring
- 6 Support ring
- 7 Output shaft

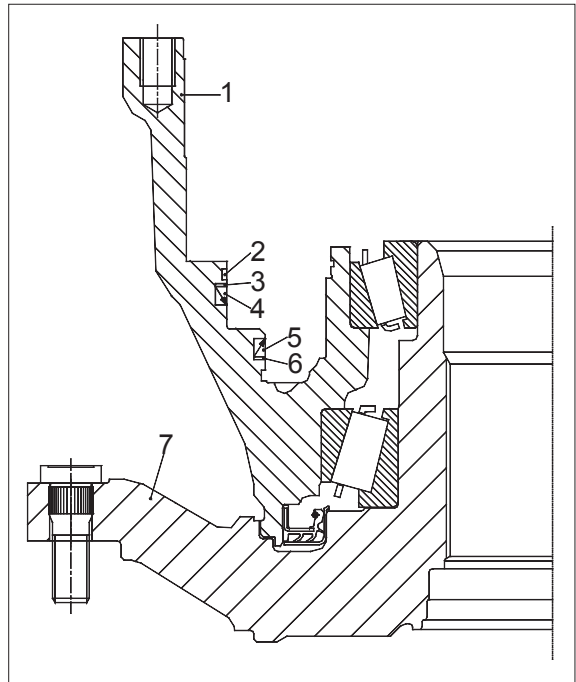

7577AAXF030

(29) Pull brake housing by means of two-armed puller from the output shaft and remove the released bearing inner ring.

※ Special tool

- | | |
|------------------|--------------|
| Two-armed puller | 5870 970 007 |
| Clamping bracket | 5870 654 034 |
| Press bush | 5870 506 140 |



7577AAXF031

(30) Lift brake housing with lifting tackle from the output shaft.

※ Special tool

Lifting chain 5870 281 047

Eye bolts 5870 204 071

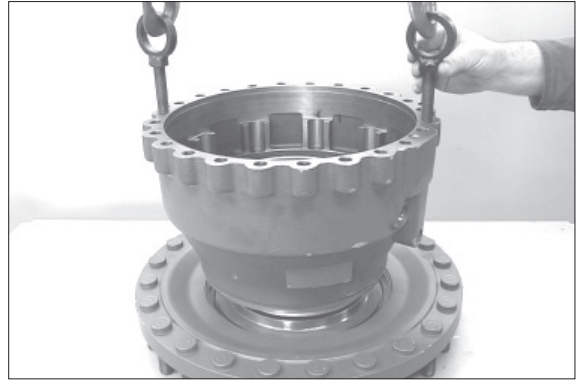

7577AAXF032

(31) If necessary drive both bearing outer rings out of the bearing bores in the brake housing.



7577AAXF033

(32) Press shaft seal out of the brake housing.

※ Special tool

Pry bar set 5870 345 065



7577AAXF034

(33) Pull bearing inner ring from the output shaft.

※ Special tool

Rapid grip 5873 014 013

Basic set 5873 004 001

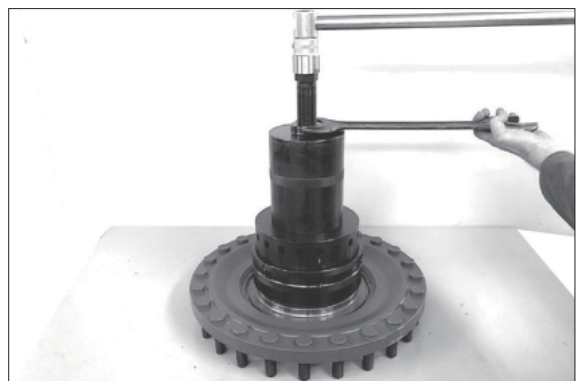

7577AAXF035

(34) Press off bearing sheet from the output shaft.

※ Special tool
Pry bar set

5870 345 065

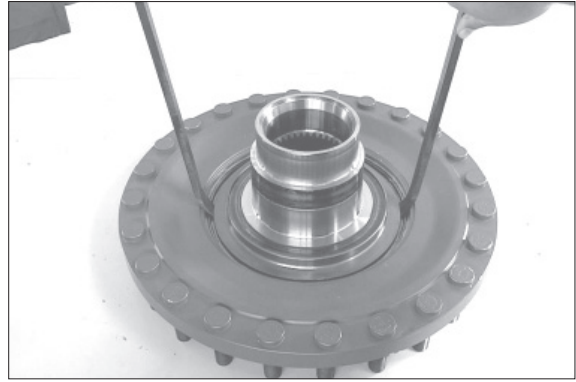

7577AAXF036

2) REASSEMBLY OF OUTPUT AND BRAKE

(1) Insert wheel bolt into the output shaft until contact.

※ Special tool

Wheel bolt puller-basic set 5870 610 010

Insert (7/8"-14 UNF) 5870 610 011

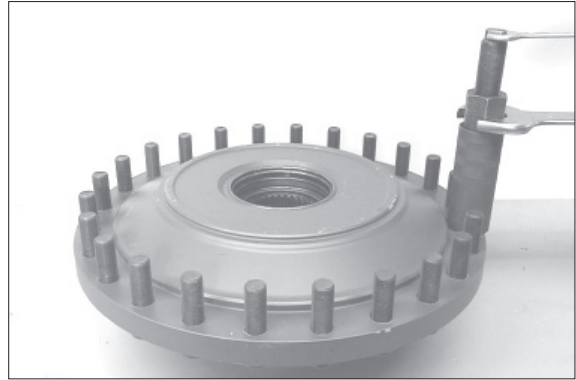

7577AAXF037

(2) Assemble bearing sheet (shaft seal).

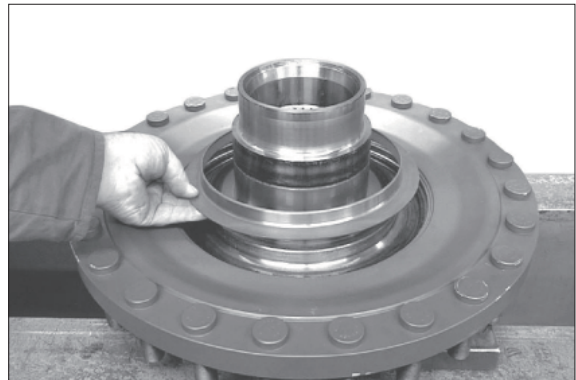

7577AAXF038

(3) Press bearing sheet over the collar of the output shaft.

※ Special tool

Pressure ring 5870 506 141

※ The exact installation position of the bearing sheet will be obtained by using the specified pressure ring.

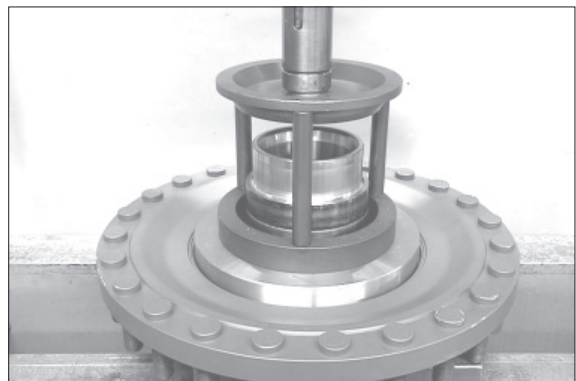

7577AAXF039

(4) Heat the roller bearing and install it until contact.

※ After cooling-down the bearing has to be installed subsequently.



7577AAXF040

- (5) Press both bearing outer rings into the brake housing until contact.

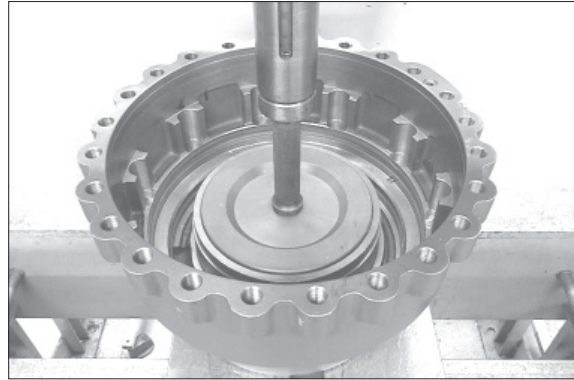

7577AAXF041

- (6) Install shaft seal with the sealing lip showing to the oil chamber (see below sketch).

- ※ Special tool
Driver 5870 051 052
- ※ The exact installation position of the shaft seal will be obtained by using the specified driver.

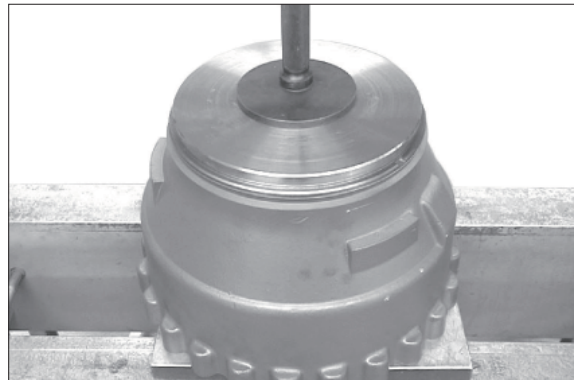

7577AAXF042

- ▲ **Just before the installation wet the outer diameter of the shaft seal with spirit.**

To the sketch :

- 1 Brake housing
- 2 Shaft seal
- * Grease filling

- ※ Fill the space between sealing and dust lips with grease.

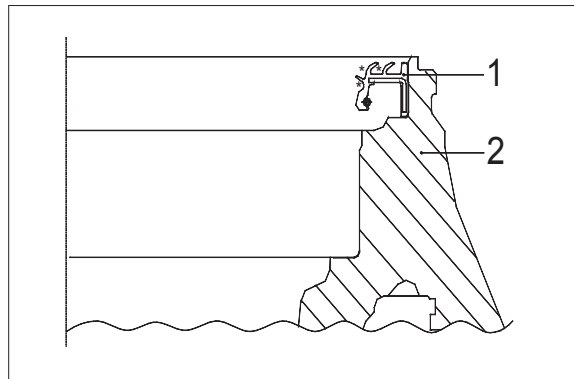

7577AAXF043

- (7) Install the preassembled brake housing by means of the lifting tackle over the output shaft until contact.

- ※ Special tool
Lifting chain 5870 281 047
Eye bolts 5870 204 071

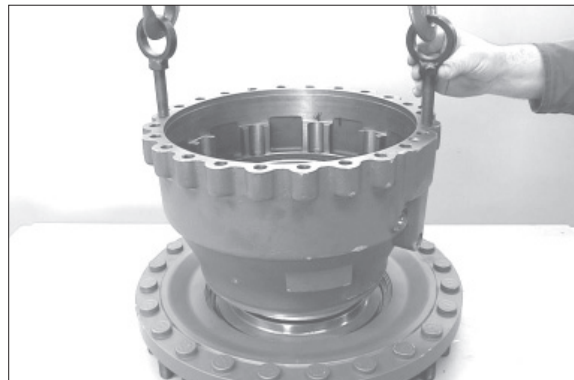

7577AAXF044

(8) Heat the roller bearing and install it until contact.



7577AAXF045

(9) Insert support and U-rings into the annular grooves of the brake housing.

※ Pay attention to the installation position, see below sketch.

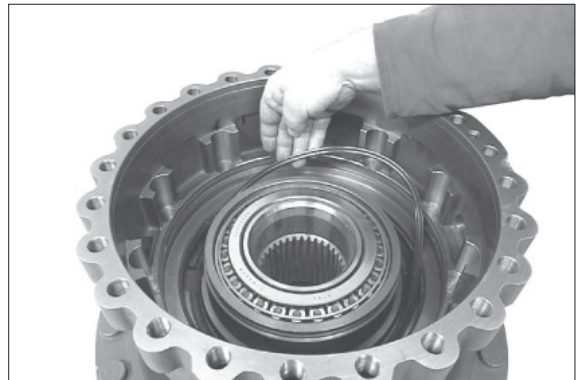

7577AAXF046

To the sketch :

- 1 Brake housing
- 2 Guide ring
- 3 Support ring
- 4 U-ring
- 5 U-ring
- 6 Support ring
- 7 Output shaft

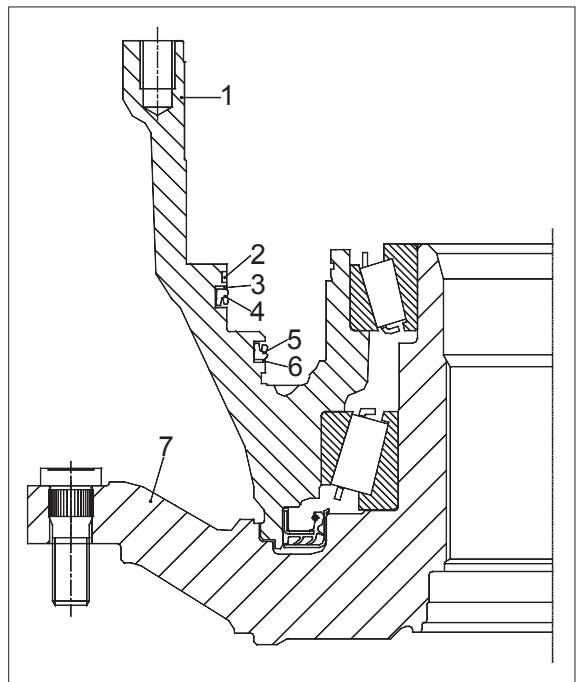

7577AAXF047

(10) Clean annular groove of the brake housing with spirit.

Then insert the guide ring into the annular groove (also see sketch page 3-141) and fix it with Loctite (type No. 415) at its extremities.

※ Guide ring must have contact on the whole circumference.

▲ Upon installation the orifice of the guide ring must show upwards (12 o'clock).

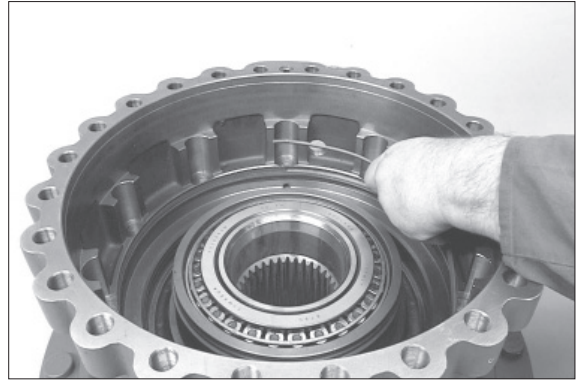

7577AAXF048

(11) Insert piston into the brake housing and install it cautiously until contact.

※ Apply sufficiently oil on the sliding surface of the piston or support rings, U-rings and guide ring (use W-10 oils).

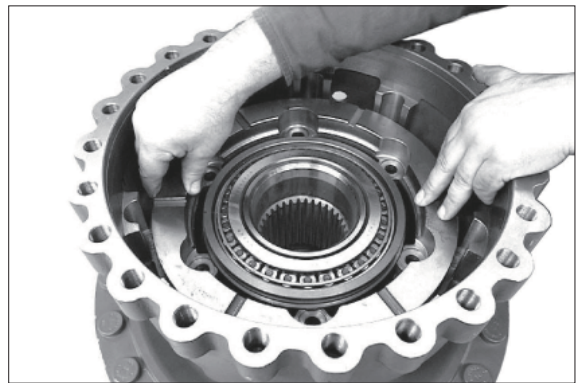

7577AAXF049

(12) Insert pins into the assembly fixture until contact.

※ Special tool

Assembly fixture 5870 345 096

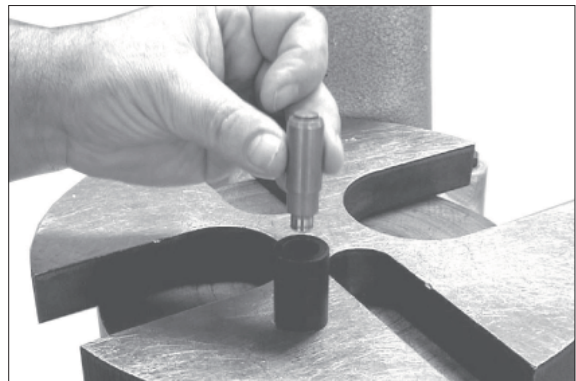

7577AAXF050

(13) Press gripping rings (4EA, see arrows) onto the pins until contact on the assembly fixture.

※ The exact installation dimension (see sketch page 3-143) of the gripping rings is obtained when using the specified assembly fixture.

▲ Observe the installation position, install gripping rings with the orifices offset by 180° to each other.

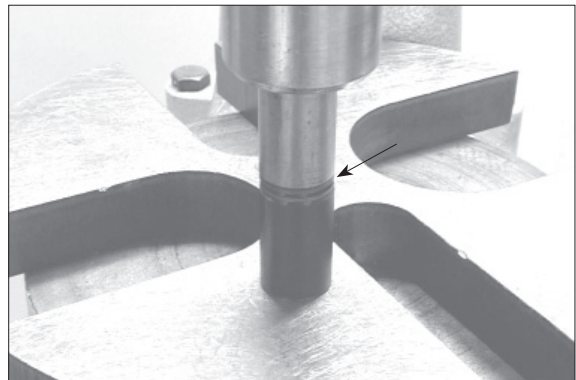

7577AAXF051

(14) Install cup springs (7 pieces each/pin).

- ※ Pay attention to the installation position of the cup springs, see below sketch.



7577AAXF052

To the sketch :

- 1 Pin
- 2 Gripping rings
- 3 Cup springs
- 4 Support shim
- 5 Circlip
- X Installation dimension gripping rings
10.5 $+0.3$ mm

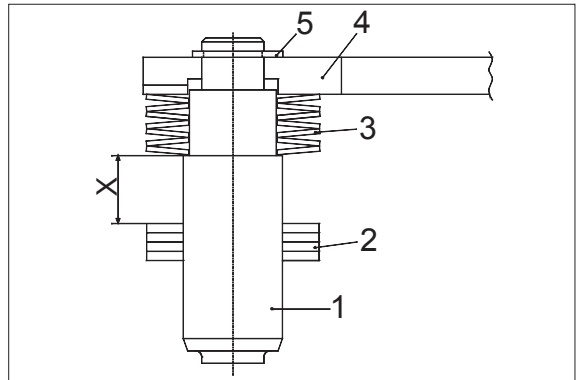

7577AAXF053

(15) Insert preassembled pins into the support shim and fix it by means of the circlip.

- ※ Special tool
Assembly pliers 5870 900 051
- ※ Pay attention to clearance of the cup springs.

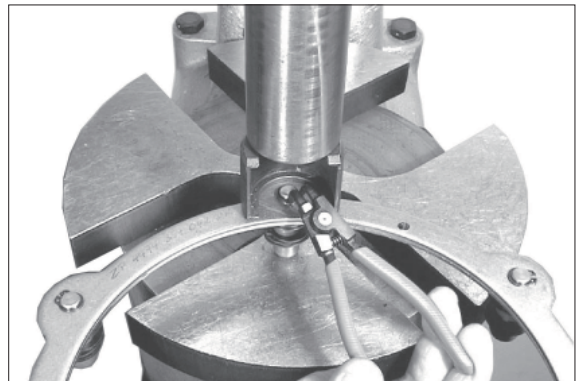

7577AAXF054

(16) Insert preassembled support shim into the piston.

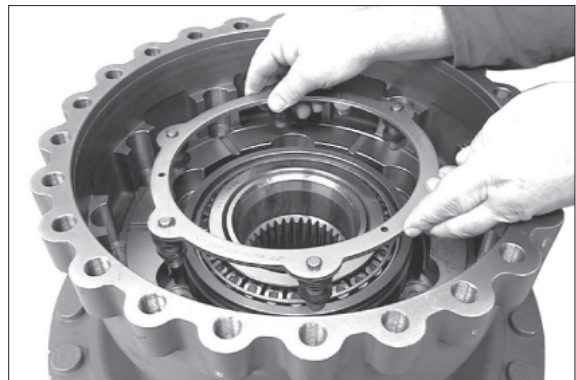

7577AAXF055

(17) Fix support shim by means of the circlip.

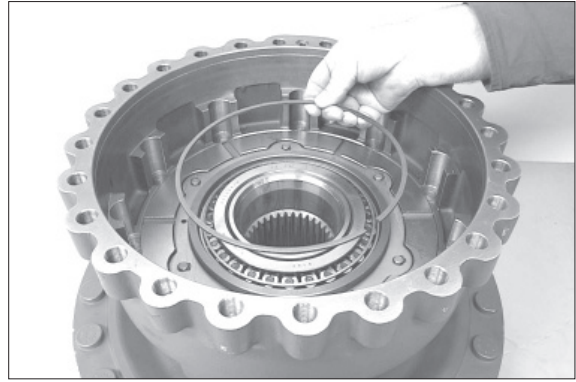

7577AAXF056

(18) Drive slotted pins (6EA) into the bores of the support shim to lock the circlip.

- ※ Special tool
Drive mandrel 5870 705 011
- ※ Pay attention to the installation position, see below sketch.

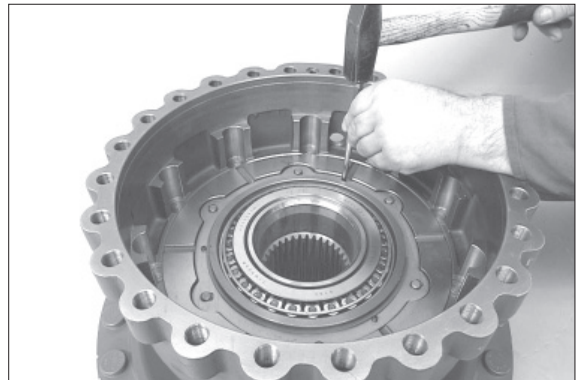

7577AAXF057

To the sketch :

- 1 Brake housing
- 2 Circlip
- 3 Slotted pin
- 4 Support shim
- 5 Piston
- X Installation dimension $4.0_{-0,5}$ mm

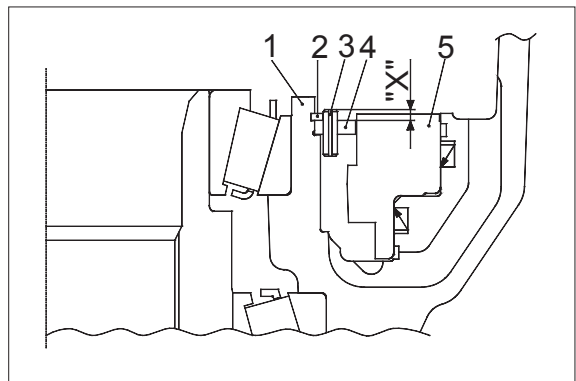

7577AAXF058

(19) Drive stop bolt into the planet carrier until contact.

Then wet spline (see arrow).

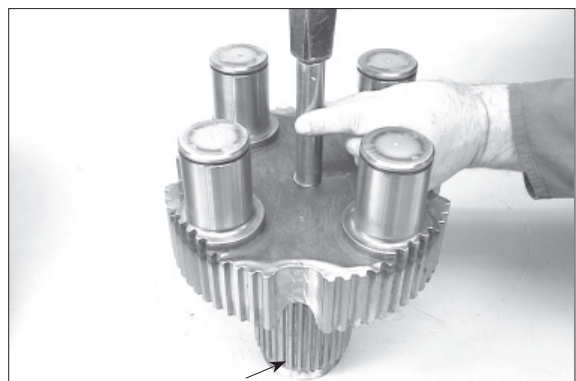

7577AAXF059

(20) Insert planet carrier into the spline of the output shaft until contact.

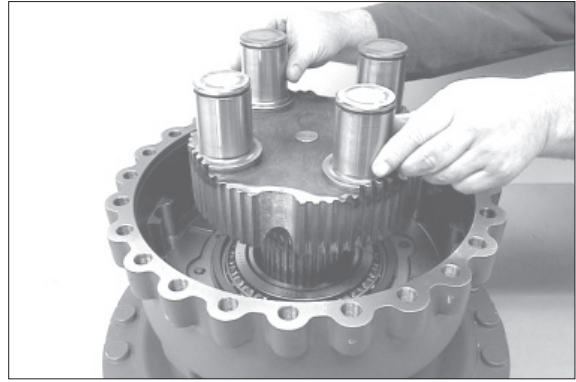

7577AAXF060

(21) Install outer-and inner clutch discs alternately starting with an outer clutch disc.

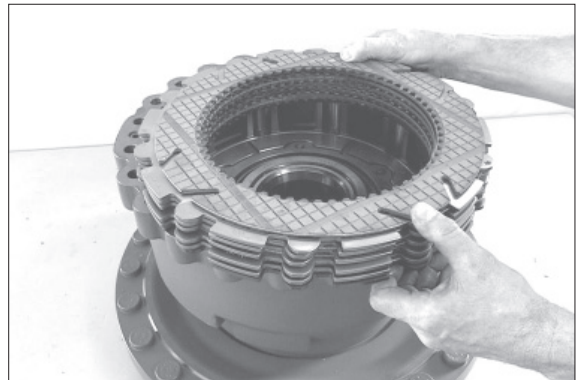

7577AAXF061

(22) Insert O-ring (see arrow) into the recess of the brake housing.

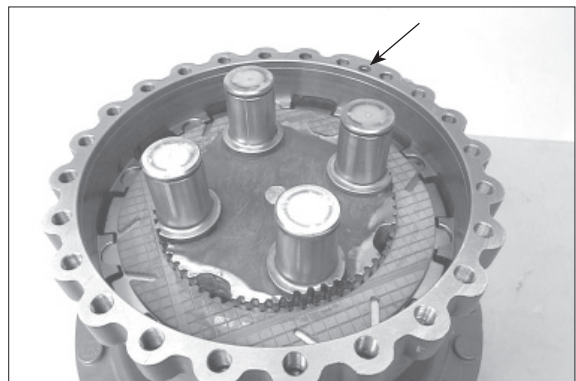

7577AAXF062

(23) Grease both O-rings (see arrows) and insert them into the annular grooves of the ring gear.

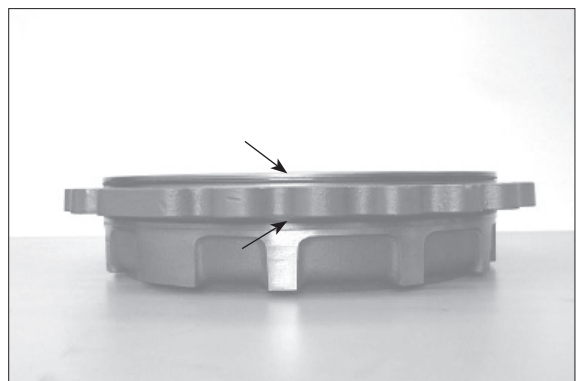

7577AAXF017

(24) Install two adjusting screws and insert ring gear into the brake housing until contact.

※ Special tool

Adjusting screws 5870 204 029

※ Pay attention to radial location.

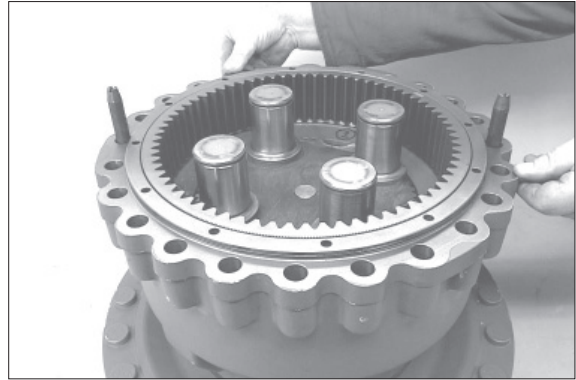

7577AAXF063

(25) Heat bearing inner rings and install them until contact with the big radius showing to the planet carrier (downwards).

※ Subsequently install bearing inner rings after cooling down.

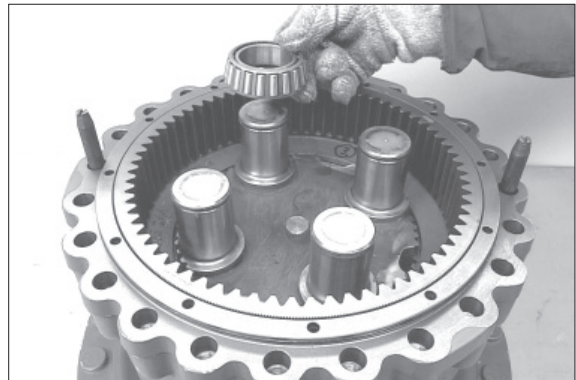

7577AAXF064

(26) Put planet gears onto the bearing inner rings.

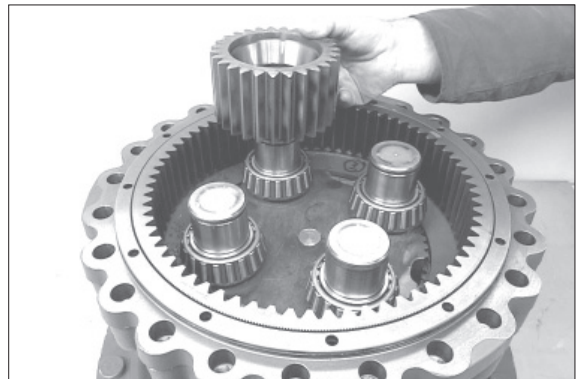

7577AAXF065

(27) Heat bearing inner rings and install them on the planet gears until contact.

※ Subsequently install bearing inner rings after cooling down.

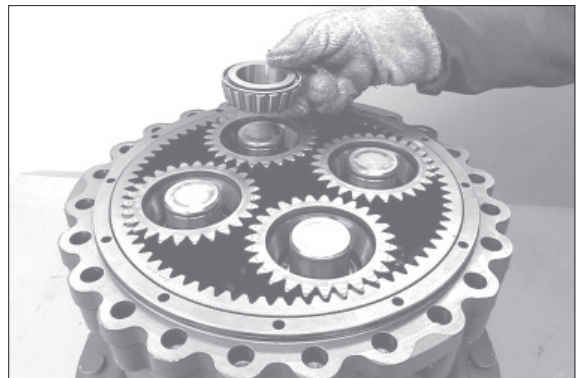

7577AAXF066

(28) Fasten plant gears by means of retaining rings.

- ※ Special tool
- Set of external pliers 5870 900 015



7577AAXF067

Adjust end play of sun gear shaft 0.5 ~ 2.0 mm

(29) Fasten ring gear by means of cap screws until contact.

Then determine dimension I, from the mounting face of the ring gear up to the face of the stop bolt.

Dimension I e.g 46.20 mm

- ※ Special tool
- Digital depth gauge 5870 200 072
- Gauge blocks 5870 200 066
- Straightedge 5870 200 022

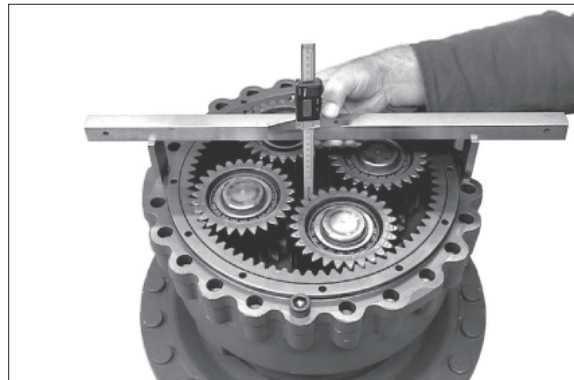

7577AAXF068

(30) Insert stub shaft into spline of the axle bevel gear until contact.

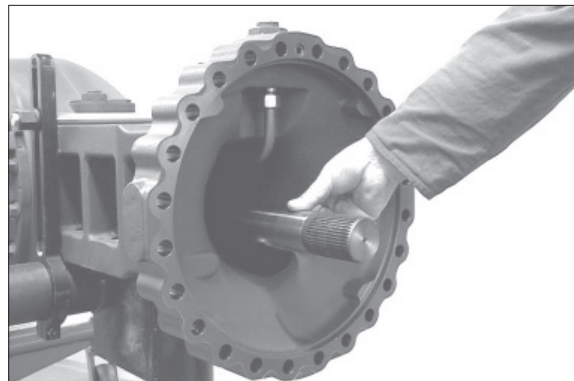

7577AAXF069

(31) Assemble sun gear shaft until contact.

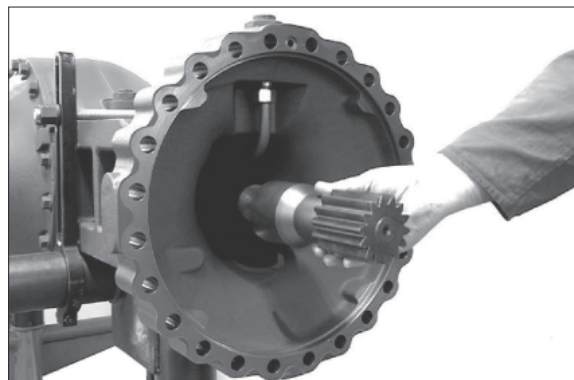

7577AAXF070

(32) Determine Dimension II from the face of the sun gear shaft up to the mounting face of the axle casing.

Dimension II e.g.43.00 mm

※ Special tool

Digital depth gauge 5870 200 072

Gauge blocks 5870 200 066

Straightedge 5870 200 022

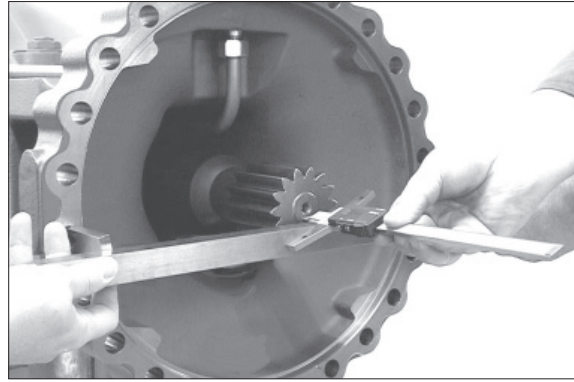

7577AAXF071

EXAMPLE A :

Dimension I 46.20 mm

Dimension II - 43.00 mm

Difference 3.20 mm

required end play e.g. - 1.00 mm

Difference = shim e.g. s = 2.20 mm

(33) Insert sun gear shaft into the planet carrier.

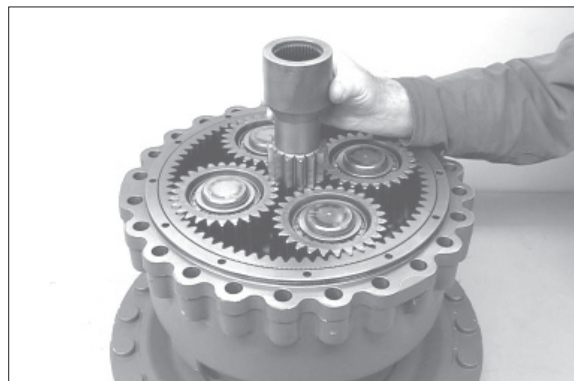

7577AAXF072

(34) Fix determined shim (s), e.g. $s = 2.20$ mm, into the sun gear shaft by means of grease.



7577AAXF073

(35) Fix O-ring (see arrow) into the recess of the axle casing by means of grease and install the preassembled output to the axle casing until contact by means of lifting tackle.

※ Special tool
Lifting bracket 5870 281 043

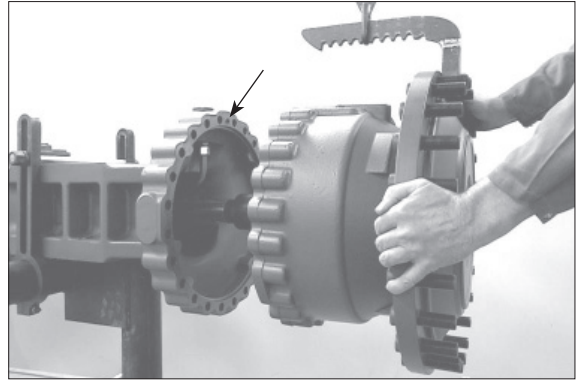

7577AAXF074

(36) Fasten output by means of hexagon screws and washers.

· Tightening torque (M18/10.9) :
39.8 kgf · m (288 lbf · ft)

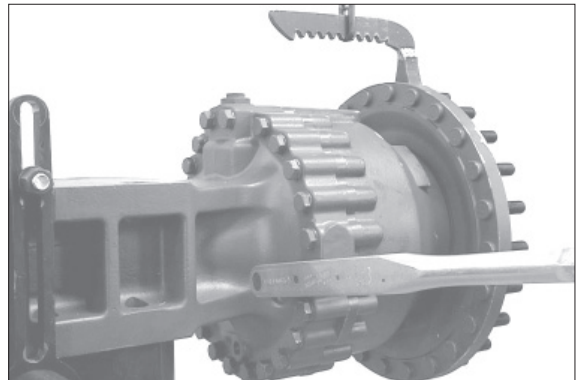

7577AAXF075

(37) Unscrew slotted nut by hand and then fasten it.

· Tightening torque : $153^{+20.4}$ kgf · m
(1107^{+148} lbf · ft)

※ Special tool
Socket spanner 5870 656 078
Centering bracket 5870 912 028

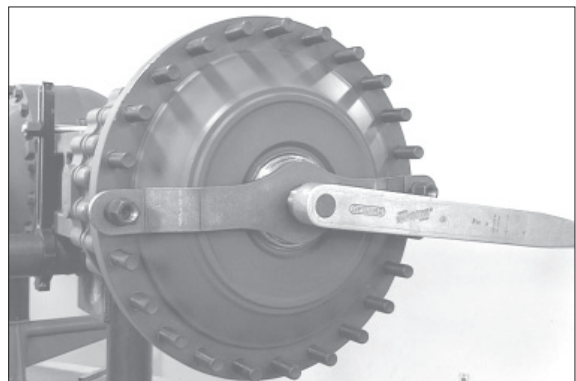

7577AAXF076

(38) Secure slotted nut by means of slotted pin.



7577AAXF077

(39) Assemble O-ring (see arrow) to the cover.



(40) Insert cover into the output shaft until contact.

- ※ Special tool
Hammer (plastic \varnothing 60) 5870 280 004



7577AAXF079

Leakage test of the brake hydraulics

- ※ Prior to start the test, ventilate the brake hydraulics completely.

- 1) Open the bleeder.
- 2) Slowly actuate the HP-pump until oil flows out of the bleeder.
- 3) Close the bleeder again.
- 4) Slowly pressurize the HP-pump with $p > 10$ bar and hold the pressure for some seconds.

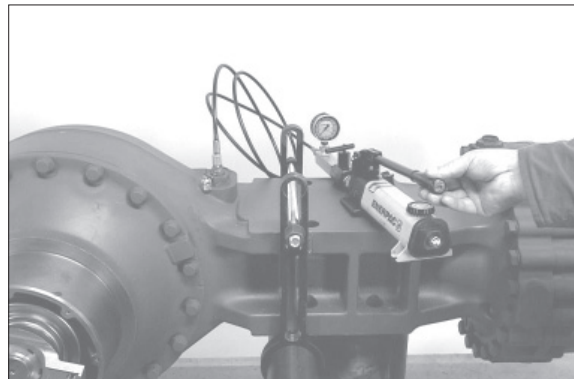

- ※ The brake piston extends and the cylinder chamber fills up with oil. The air accumulates in the upper section of the cylinder chamber.
- 5) Loosen the shut-off valve on the HP-pump.
 - ※ The reversing piston presses the air from the upper section of the cylinder into the brake line.
 - 6) Open the bleeder again.
 - 7) Slowly actuate the HP-pump until oil flows out of the bleeder.
- ※ Repeat procedure - Item 3)~7) until at 7) from the beginning of the actuation no more air exits from bleeder.
 - ※ Then pressurize the brake temporarily (5EA) with $p = 100$ bar max..

High-pressure test :

Increase test pressure up to $p = 100_{.10}$ bar and close connection to HP-pump by means of shut-off valve.

During a 5 min. testing time a pressure drop of max. 2% (2 bar) is allowed.

- ▲ If the maximum pressure of 100 bar is exceeded, there will be an excessive piston adjustment and a repeated disassembly of the brake or the adjusting is required to reset the gripping rings to the adjusting dimension.**

Low-pressure test :

Reduce test pressure to $p = 5$ bar and close the shut-off valve again.

During a 5 min. testing time a pressure drop is not allowed.

- ※ Special tool

HP-Pump 5870 287 007

Mini-measuring hub 5870 950 115

(9/16"- 18UNF)

- ※ Prior to putting the axle into operation, fill in the oil acc. to the lubrication instructions.

3) DISASSEMBLY OF DIFFERENTIAL CARRIER AND BRAKE TUBES

(1) Disassembly of differential carrier

① Fasten axle on assembly truck.

※ Special tool

Assembly truck 5870 350 000

Holding fixtures 5870 350 077

Clamps 5870 350 075

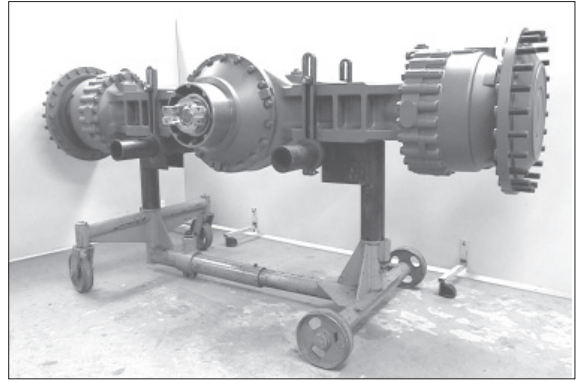

7577AAXF001

② Loosen screw plugs (3EA, see Figure 7577AAXF002 and 003) and drain oil from axle casing.

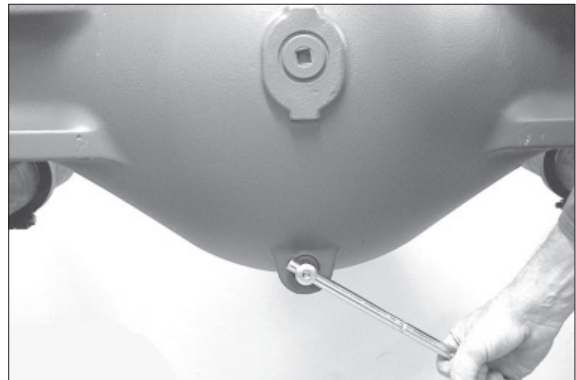

7577AAXF002

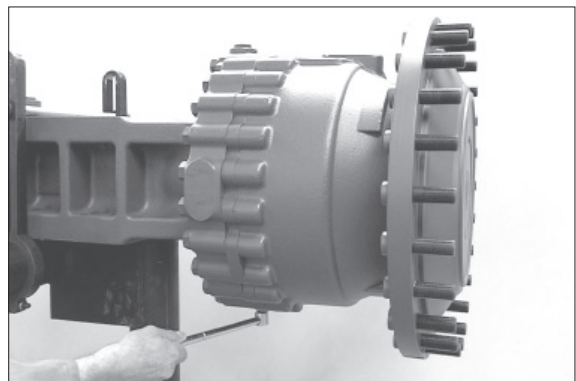

7577AAXF003

③ Secure output by means of lifting tackle and loosen hexagon screws.

※ Special tool

Lifting bracket 5870 281 043

※ Make step (fig. 7577AAXF007~9) on both output sides.

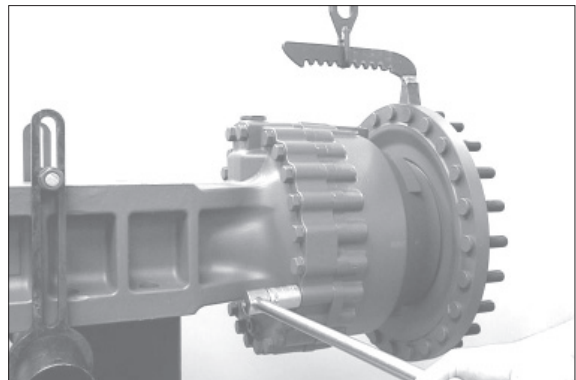

7577AAXF007

④ Separate complete output from the axle casing.

※ Pay attention to released O-ring (see arrow).

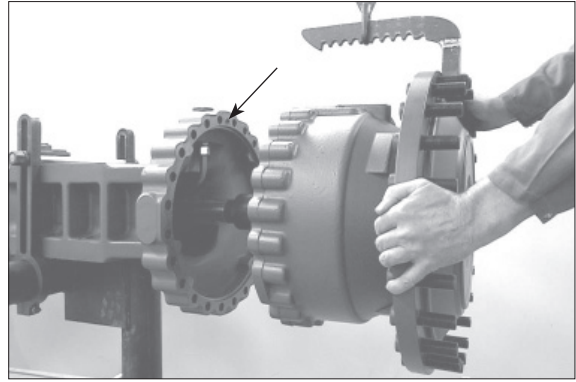

7577AAXF008

⑤ Pull stub shaft out of the sun gear shaft.

※ Pay attention to released shim (s).

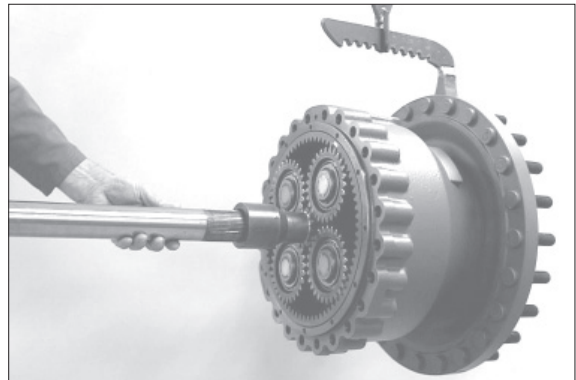

7577AAXF009

⑥ Loosen hexagon screws.

※ Mark location of differential carrier to the axle casing (see arrows).

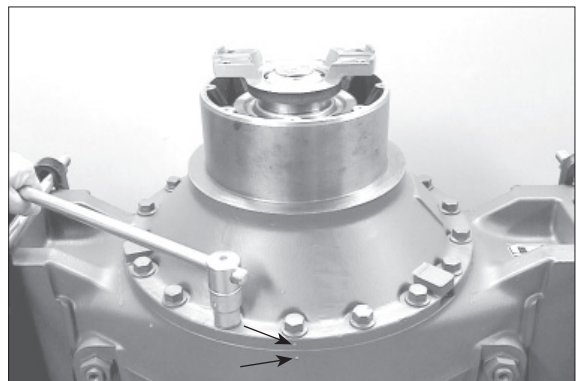

7577AAXF081

⑦ Lift differential carrier by means of lifting tackle out of the axle casing.

※ Special tool

Lifting tackle

5870 281 044

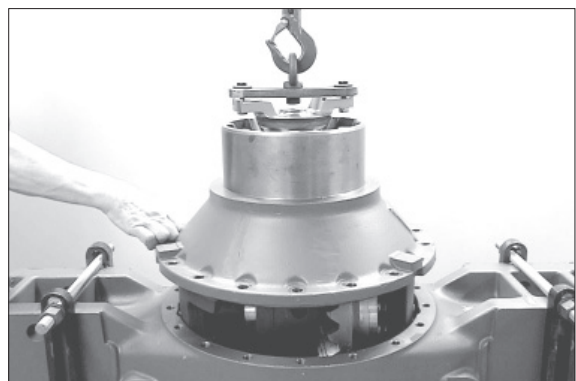

7577AAXF082

⑧ Fasten differential carrier to assembly truck.

※ Special tool

Assembly truck 5870 350 000

Holding fixture 5870 350 034

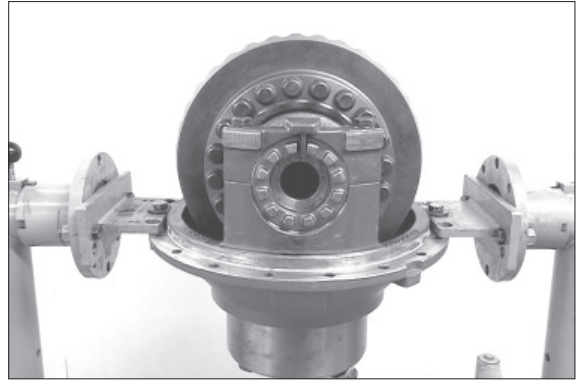

7577AAXF083

⑨ Drive out slotted pins.

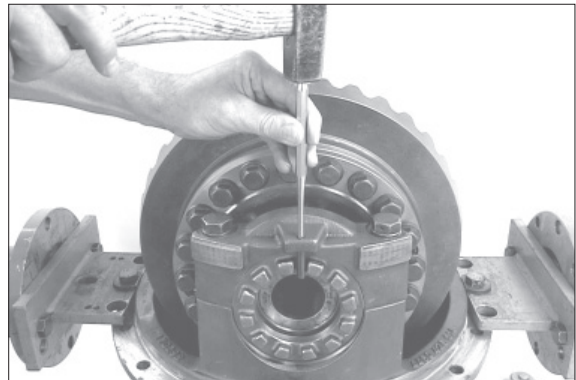

7577AAXF084

⑩ Loosen and remove both adjusting nuts.

※ Special tool

Socket spanner 5870 656 079

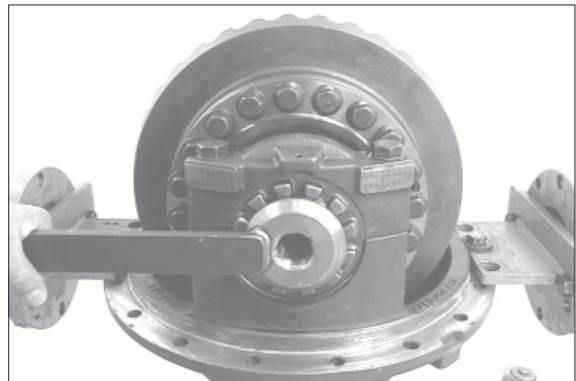

7577AAXF085

⑪ Heat axle drive housing by means of hot-air blower.

※ Special tool

Hot-air blower 230 V 5870 221 500

Hot-air blower 115 V 5870 221 501

※ Hexagon screws are installed with Loctite (type No. 262).

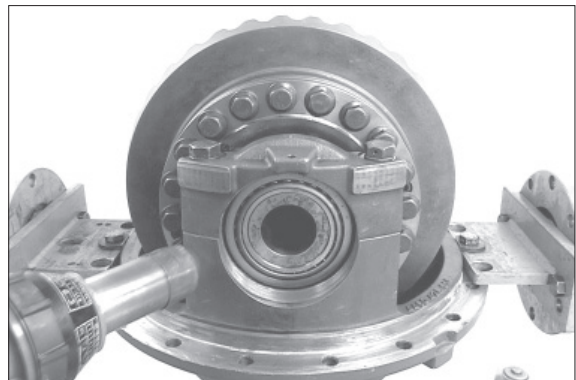

7577AAXF086

⑫ Loosen hexagon screws and take off bearing bracket.

▲ Loosen hexagon screws by hand only.

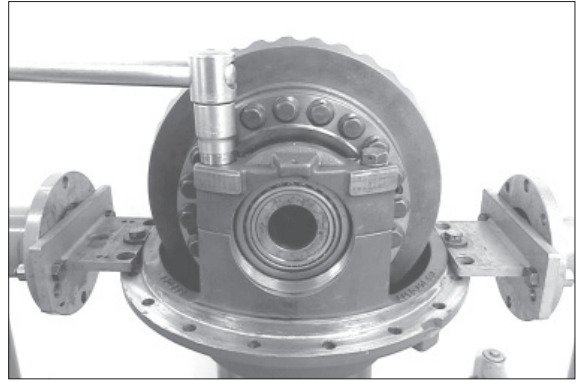

7577AAXF087

⑬ Remove both bearing outer rings.

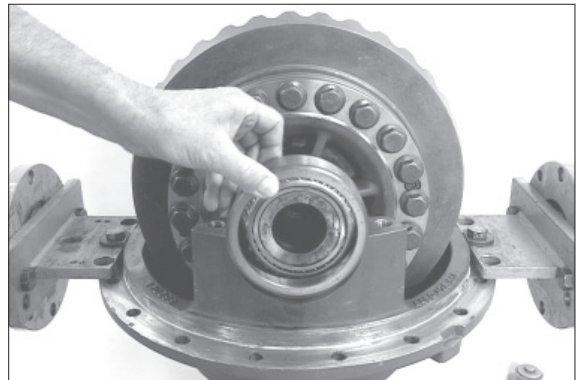

7577AAXF088

⑭ Lift differential out of the housing by means of lifting tackle.

※ Special tool
Lifting tackle 5870 281 013

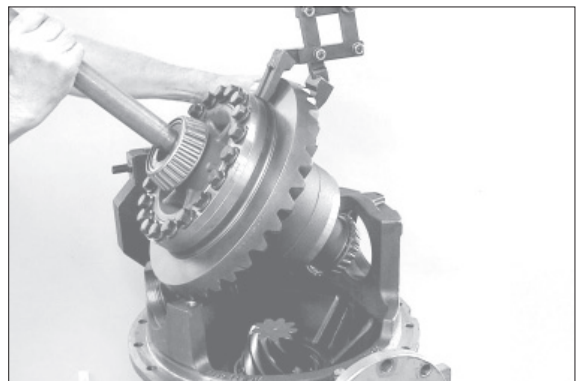

7577AAXF089

Disassembly of limited slip differential

⑮ Pull bearing inner ring from the differential housing.

※ Special tool
Gripping insert 5873 002 023
Basic set 5873 002 001

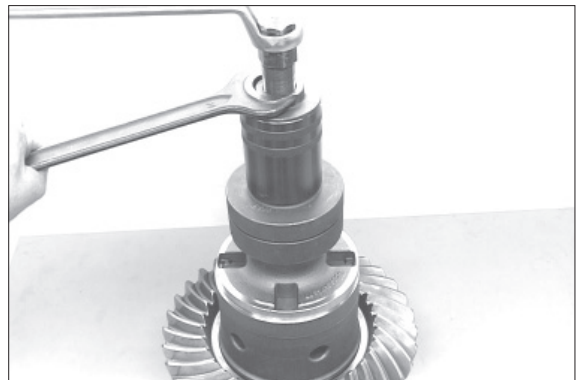

7577AAXF090

⑩ Pull bearing inner ring from the housing cover.

※ Special tool

Rapid grip

5873 012 018

Basic set

5873 002 001

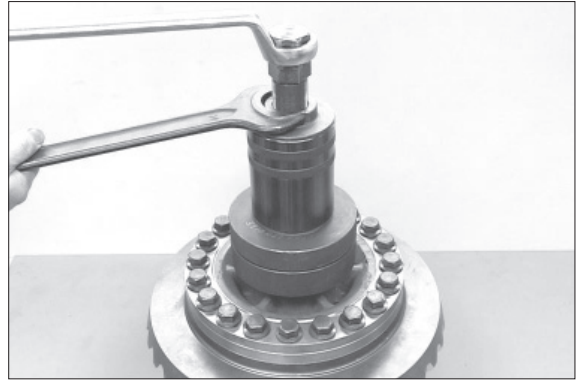

7577AAXF091

⑪ Fasten differential by means of press and loosen locking screws.

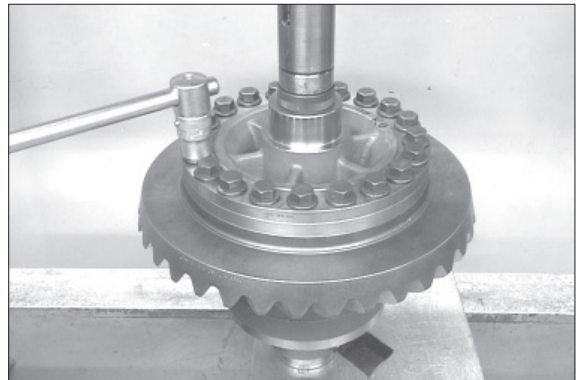

7577AAXF092

⑫ Loosen cap screws and remove released housing cover.

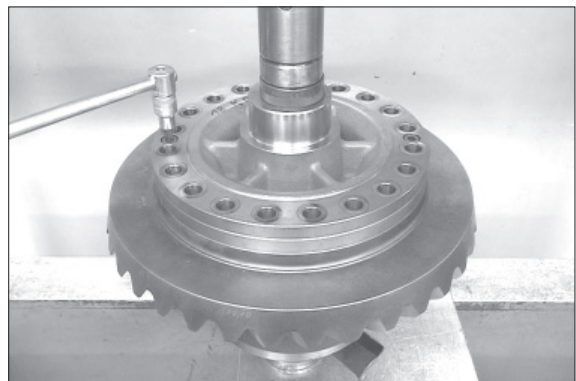

7707AAXR001

⑬ Remove all single parts from the differential housing.

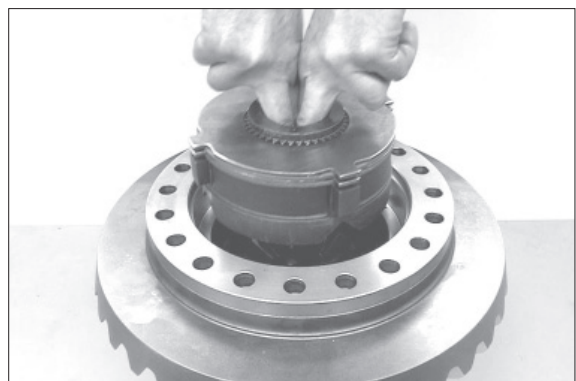

7577AAXF093

- ②① Press off crown wheel from the differential housing.

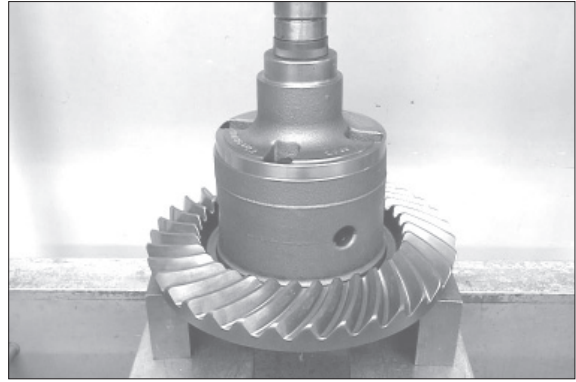

7577AAXF094

Disassembly of drive pinion

- ②① Heat slotted nut by means of hot-air blower.

※ Special tool

Hot-air blower 230 V 5870 221 500

Hot-air blower 115 V 5870 221 501

※ Slotted nut is locked with Loctite (type No. 262).

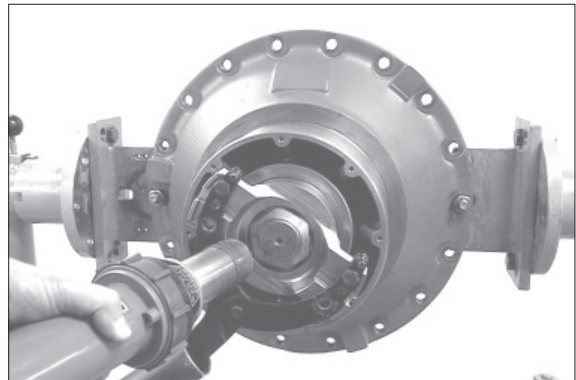

7577AAXF095

- ②② Loosen slotted nut and remove the washer behind it.

※ Special tool

Slotted nut wrench 5870 401 139

Fixture 5870 240 002

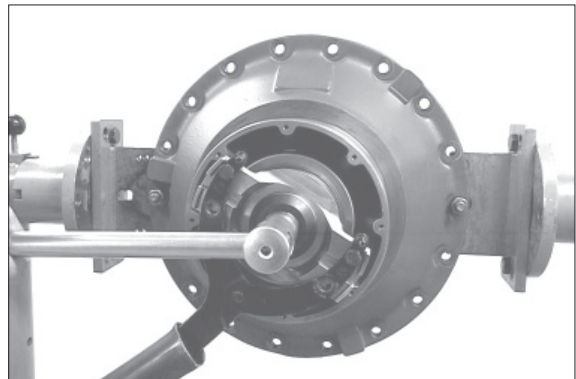

7577AAXF096

- ②③ Pull input flange from the drive pinion.

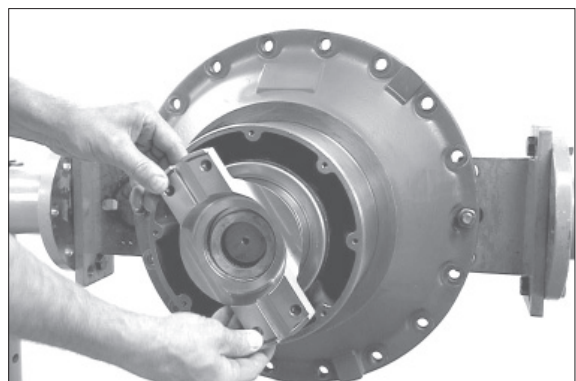

7577AAXF097

- ②④ Press shaft seal out of the axle drive housing.

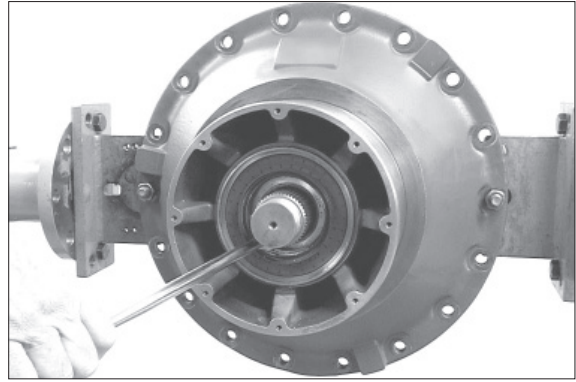

7577AAXF098

- ②⑤ Press drive pinion out of the axle drive housing by means of two-armed puller and remove the released bearing inner ring.

- ※ Special tool
Two-armed puller 5870 970 007

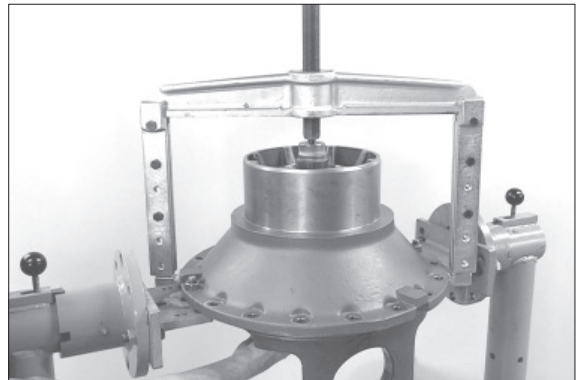

7577AAXF099

- ②⑥ Take off spacer ring and pull bearing inner ring from the drive pinion.

- ※ Special tool
Gripping insert 5873 002 032
Basic set 5873 002 001

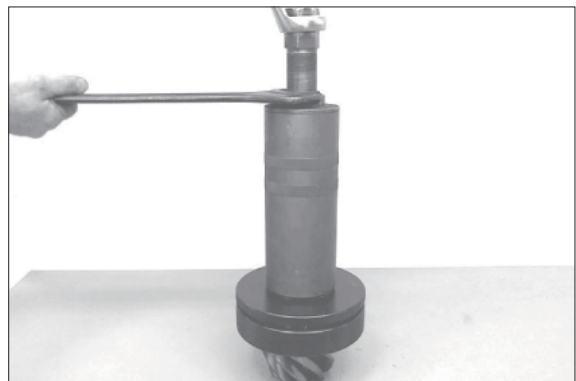

7577AAXF100

- ②⑦ If necessary drive out both bearing outer rings from the axle drive housing.

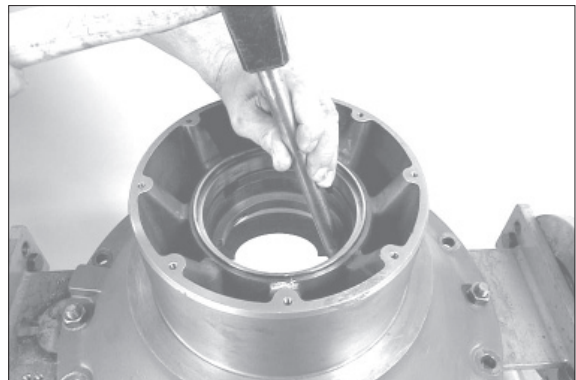

7577AAXF101

(2) Disassembly of brake tubes

- ① Remove screw plug with vent valve from the axle casing.

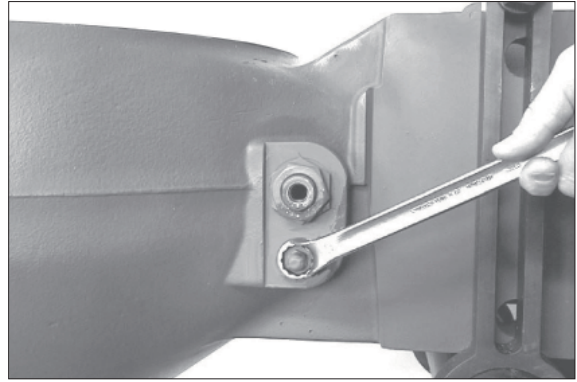

7577AAXF102

- ② Loosen hexagon nut.

※ Step (figure 7577AAXF103~107) to be made on both sides.

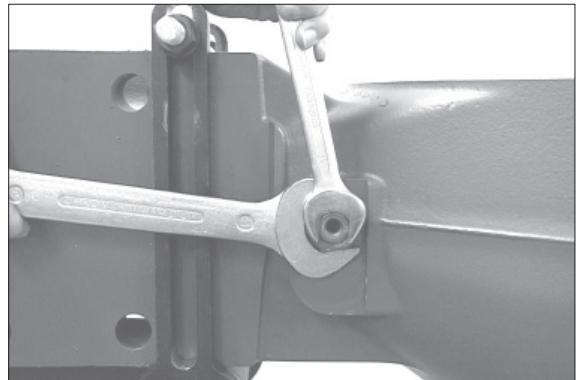

7577AAXF103

- ③ Loosen union screw.

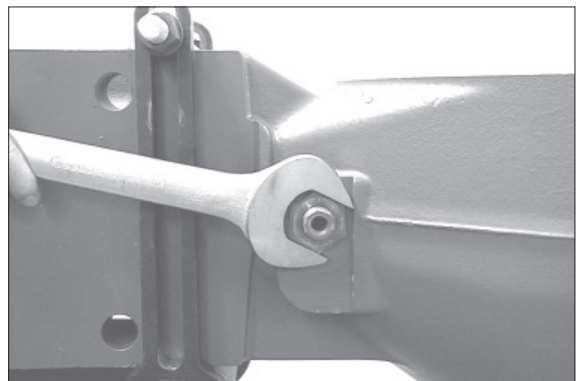

7577AAXF104

- ④ Loosen pipe union and remove released brake tube from the axle casing.

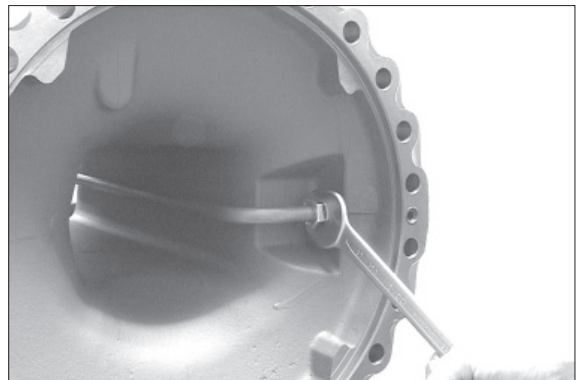

7577AAXF105

- ⑤ Remove vent valve from the connection part.

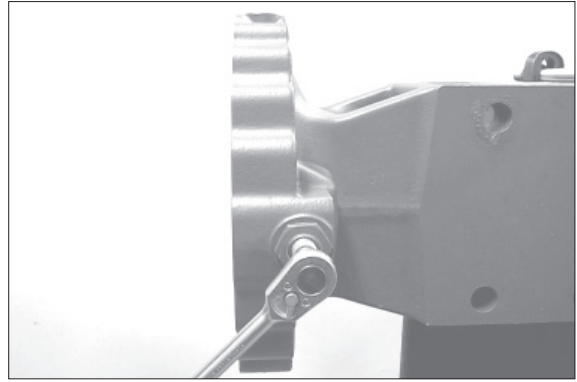

7577AAXF106

- ⑥ Loosen connection part and remove it from the axle casing.

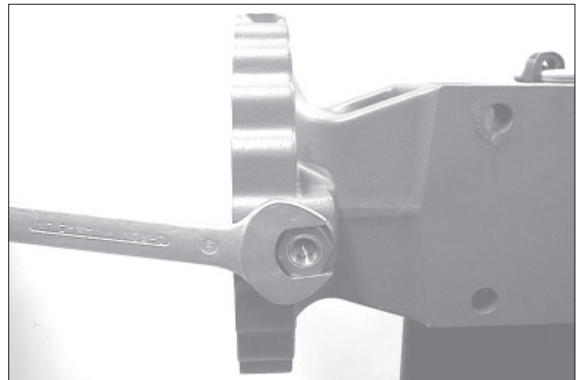

7577AAXF107

4) REASSEMBLY OF BRAKE TUBES AND DIFFERENTIAL CARRIER

(1) Reassembly of brake tubes

① Preassemble connection part as shown in opposite figure.

- 1 Vent valve
- 2 Connection part
- 3 O-Ring
- 4 Rectangular ring

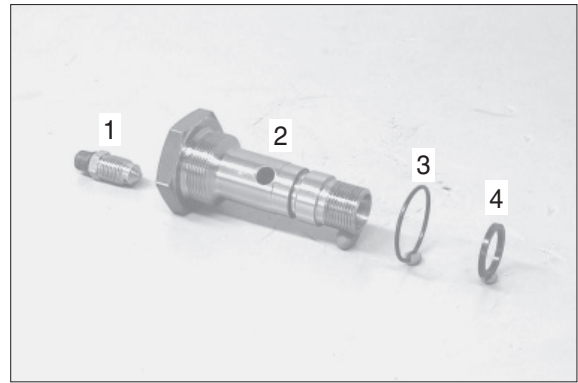

7577AAXF108

※ Step (figure 7577AAXF108~114) is to be made on both output sides.

② Install connection part.

- Tightening torque : 13.3 kgf · m
(95.9 lbf · ft)

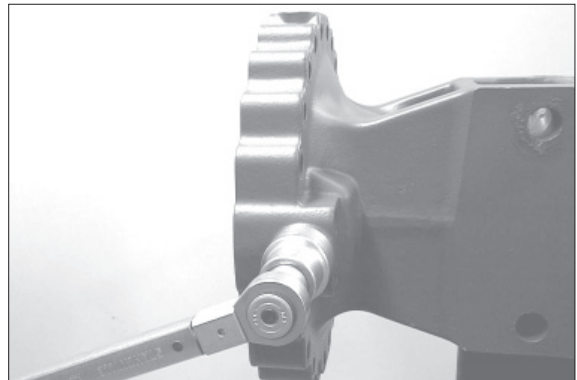

7577AAXF109

③ Provide union screw with new O-ring and install it.

- Tightening torque : 15.3 kgf · m
(111 lbf · ft)

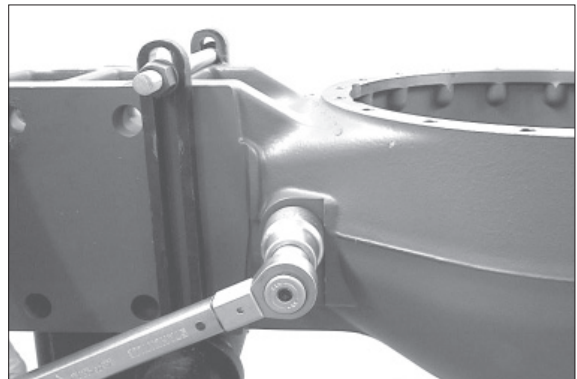

7577AAXF110

④ Insert O-ring (see arrow) into the annular groove of the brake tube.



7577AAXF111

- ⑤ Insert brake tube into the axle casing, assembling the connection part (see arrow 1) through the union screw (see arrow 2).

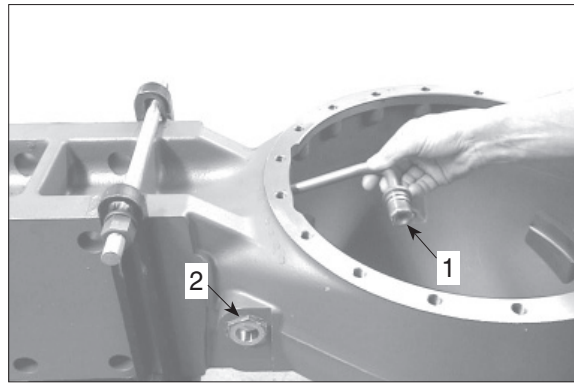

7577AAXF112

- ⑥ Fasten brake tube by means of hexagon nut and union nut (see below figure).

- Tightening torque : 10.2 kgf · m
(73.8 lbf · ft)

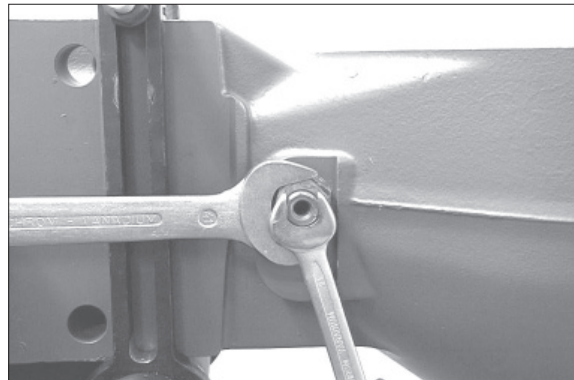

7577AAXF113

- Tightening torque : 8.2 kgf · m
(59 lbf · ft)

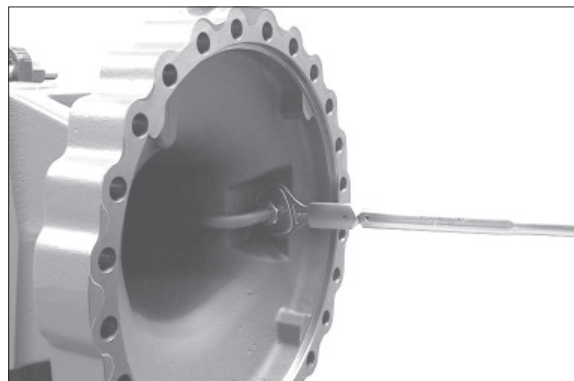

7577AAXF114

- ⑦ Preassemble screw plug as shown in opposite figure.

- 1 O-ring
- 2 Screw plug
- 3 Vent valve

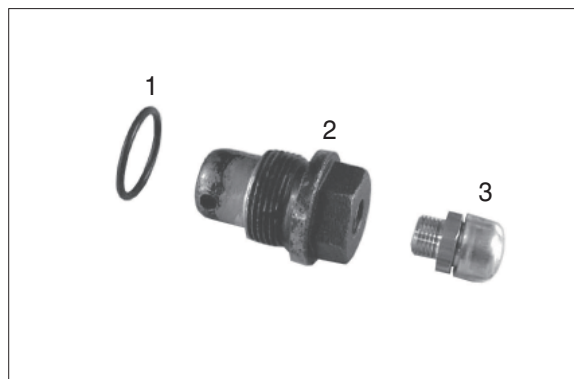

7577AAXF115

⑧ Install screw plug.

- Tightening torque : 7.1 kgf · m
(51.6 lbf · ft)

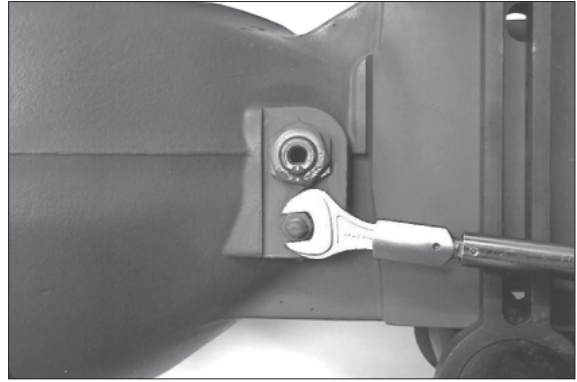

7577AAXF116

(2) Reassembly of differential carrier

※ If crown wheel or drive pinion are damaged, both parts have to be replaced together.

For new installation of a complete bevel gear set pay attention to the same pair number of drive pinion and crown wheel.

Determine shim thickness for a perfect tooth contact pattern

※ Make the following measuring steps at maximum accuracy.

Inexact measurements result in a faulty tooth contact pattern and require a repeated disassembly and reassembly of the drive pinion as well as of the differential.

① Install adapter pieces (1) and preliminarily fasten the bearing bracket by means of hexagon screws.

Then install stop washer (4) and measuring pin (3) and assemble measuring shaft (2) (see sketch).

※ Special tool

Adapter pieces	5870 500 044
Measuring shaft	5870 500 001
Measuring pin	5870 351 016
Stop washer	5870 351 029

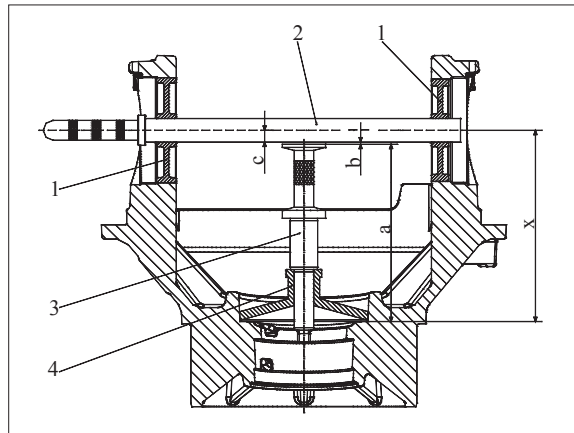

7577AAXF117

② Determine gap (dimension b) between measuring shaft and measuring pin by means of feeler gauge.

Dimension b e.g. 0.20 mm

EXAMPLE A :

Dimension a (= Measuring pin + stop washer)	206.00 mm
Dimension b	+ 0.20 mm
Dimension c	+ 15.00 mm
<u>results in dimension X</u>	<u>= 221.20 mm</u>

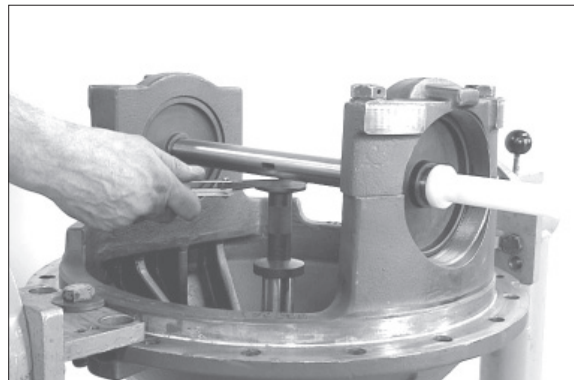

7577AAXF118

- ③ Determine dimension I (bearing width).

Dimension I e.g. 39.05 mm

※ Special tool

Digital depth gauge 5870 200 072

Gauge blocks 5870 200 066

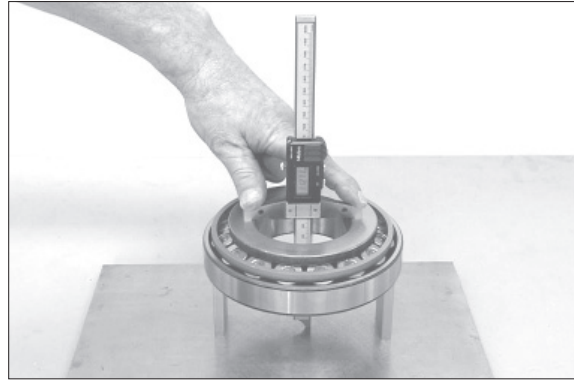

7577AAXF119

- ④ Read dimension II (dimension for pinion).

Dimension II e.g. 181.05 mm

EXAMPLE B :

Dimension I 39.05 mm

Dimension II + 181.05 mm

results in dimension Y = 220.10 mm

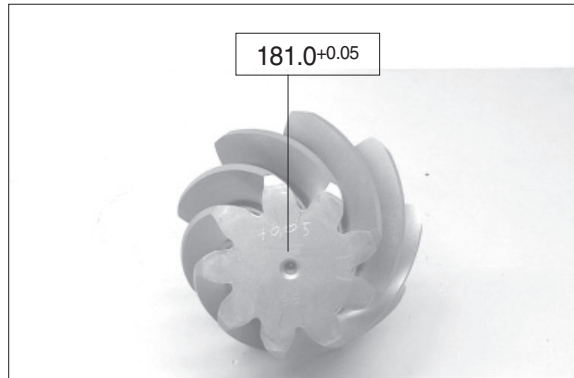

7577AAXF120

EXAMPLE C :

Dimension X 221.20 mm

Dimension Y - 220.10 mm

Difference = shim e.g. s = 1.10 mm

Install the drive pinion

- ⑤ Place determined shim e.g. $s = 1.10$ mm into the bearing bore.

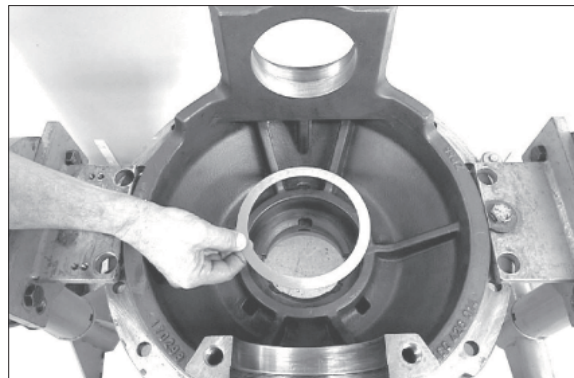

7577AAXF121

- ⑥ Undercool bearing outer ring and insert it into the bearing bore until contact.

※ Special tool

Driver 5870 058 060

Handle 5870 260 002

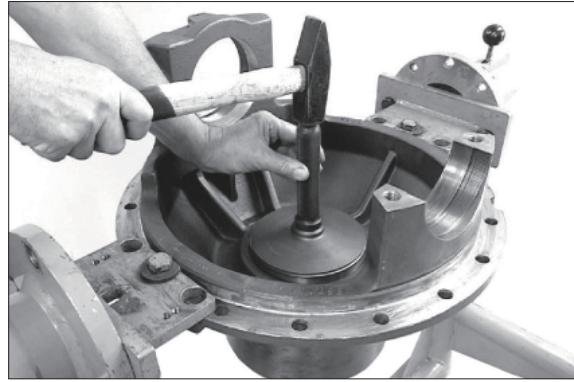

7577AAXF122

- ⑦ Undercool bearing outer ring on the input flange side and insert it until contact.

※ Special tool

Driver 5870 058 079

Handle 5870 260 002



7577AAXF123

- ⑧ Press bearing inner ring on the drive pinion until contact.

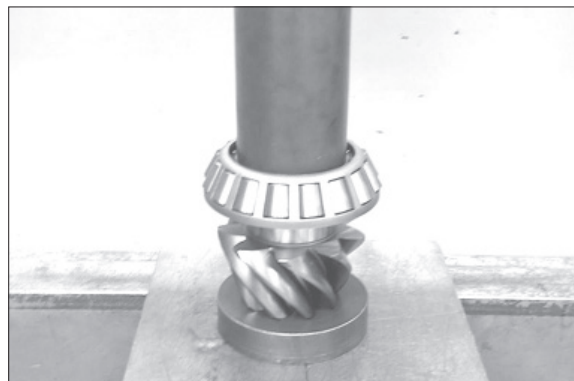

7577AAXF124

Adjust rolling moment of drive pinion bearing 0.15 ~ 0.31kgf·m (Figure 7577AAXF125~133) :

- ⑨ Assemble spacer ring (e.g. $s = 8.10$ mm).

※ As per experience the required rolling moment is obtained by use of the spacer ring (e.g. $s = 8.10$ mm) available at disassembly.

However, a later checking of the rolling moment is imperative.

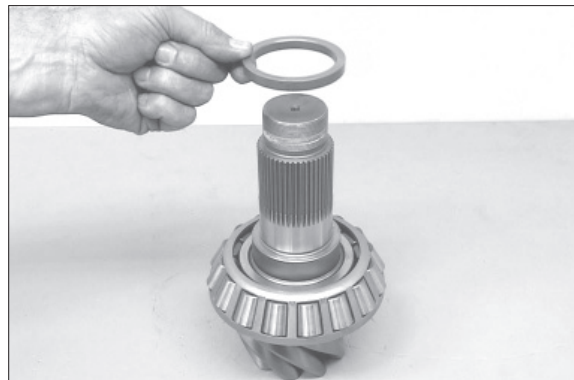

7577AAXF125

- ⑩ Insert preassembled drive pinion into the axle drive housing and assemble the heated bearing inner ring until contact.

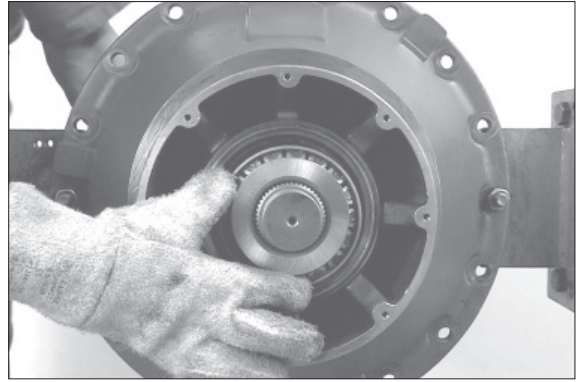

7577AAXF126

- ⑪ Press dust protection on the input flange until contact.

※ Special tool
Driver

5870 056 003

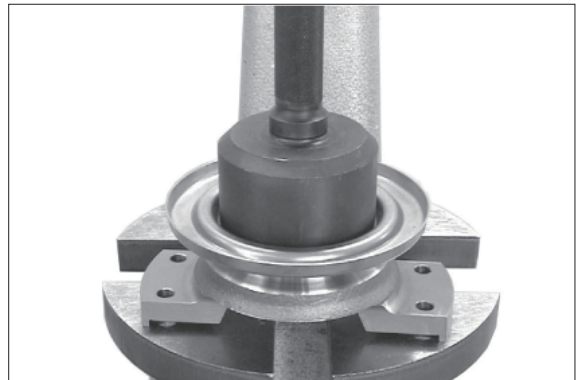

7577AAXF127

- ⑫ Assemble input flange.

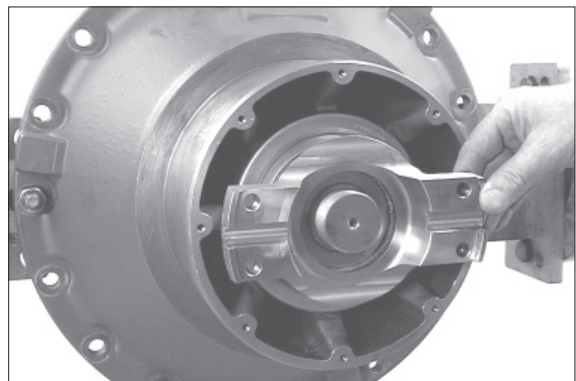

7577AAXF128

- ⑬ Assemble washer.

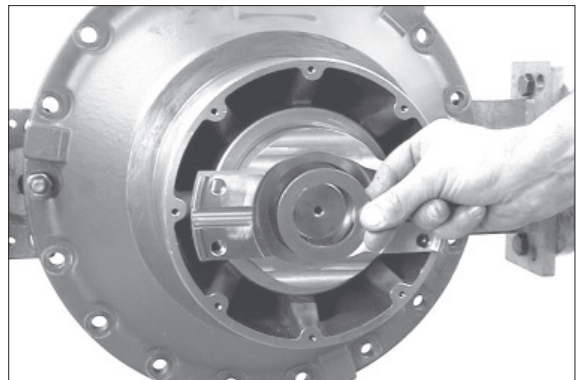

7577AAXF129

- ⑭ Unscrew hexagon nut by hand and tighten it.

· Tightening torque : 122 kgf·m
(885 lbf · ft)

※ Special tool

Slotted nut wrench 5870 401 139

Fixture 5870 240 002

※ When tightening rotate drive pinion in both directions several times.

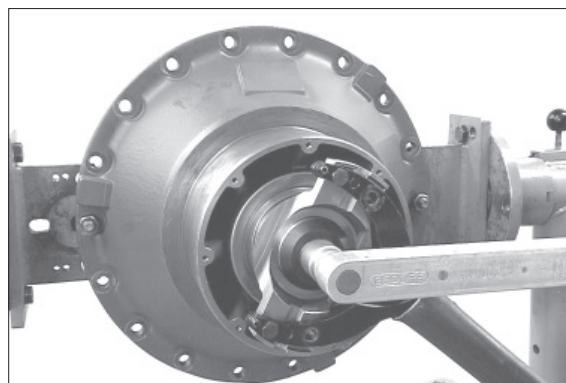

7577AAXF130

- ⑮ Check rolling moment (0.15~0.30 kgf·m).

※ For new bearings it should be tried to achieve the max. value of the rolling moment.

▲ If the required rolling moment is not obtained, correct it with an adequate spacer ring (Figure 7577AAXF125), according to the following indications :

Rolling moment too low - install a thinner spacer ring

Rolling moment too high - install a thicker spacer ring.

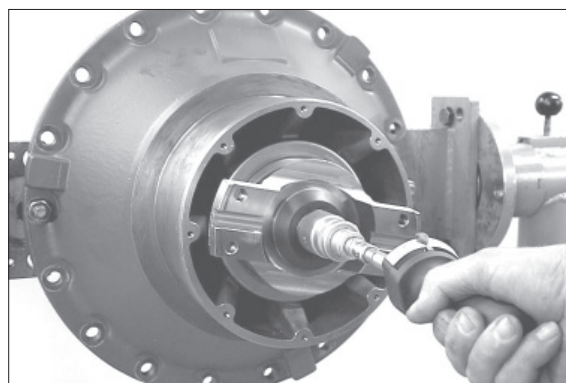

7577AAXF131

- ⑯ Then loosen the slotted nut again and pull input flange from the drive pinion.

Install shaft seal with the sealing lip showing to the oil chamber (downwards).

※ Special tool

Driver 5870 048 233

※ The exact installation position of the shaft seal will be obtained by using the exact driver.



7577AAXF132

▲ Just before the installation wet the outer diameter of the shaft seal with spirit and fill the space between sealing and dust lip with grease.

- ⑰ Assemble input flange and finally fasten it by means of washer and slotted nut.

· Tightening torque : 122 kgf·m (885 lbf·ft)

▲ Apply loctite (type No. 262) onto the thread of the slotted nut.

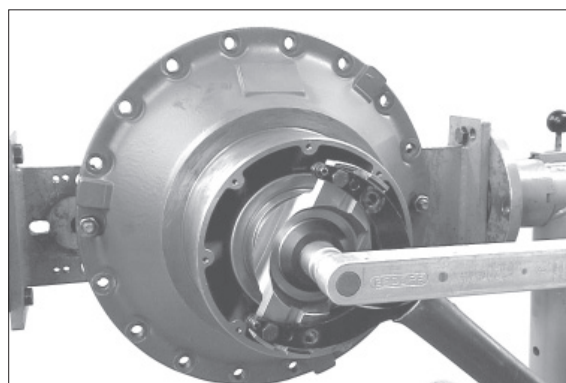

7577AAXF133

Reassembly of limited slip differential

- ⑱ Place both thrust washers into the differential housing.
- ※ Prior to installation all single parts of the differential must be oiled.

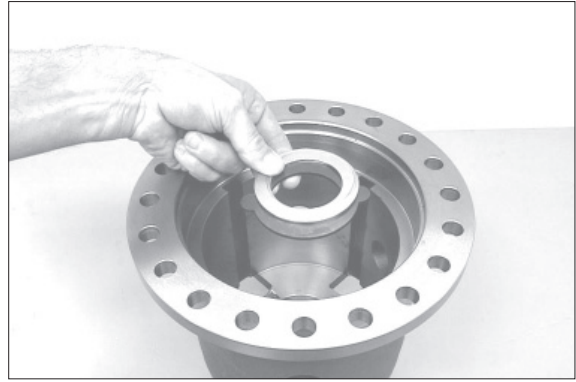

7577AAXF134

- ⑲ Starting with an outer clutch disc install alternately the outer and inner clutch discs.

▲ Thickness of the disc pack must be identical on both sides.

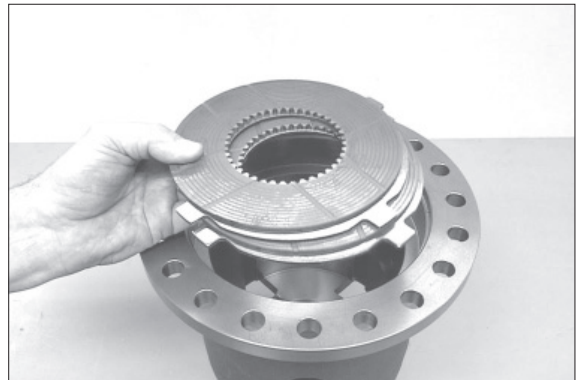

7577AAXF135

- ⑳ Put on the pressure ring.

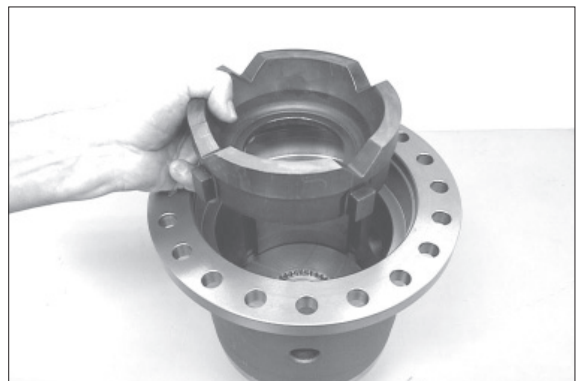

7577AAXF136

- ㉑ Insert axle bevel gear until contact and at the same time assemble all inner clutch discs with the spline.

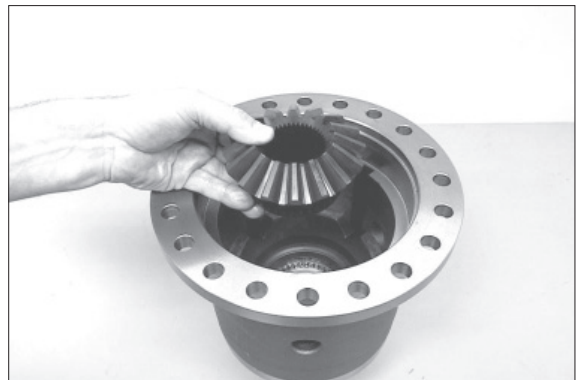

7577AAXF137

- ② Preassemble differential spider and insert it into the differential housing.

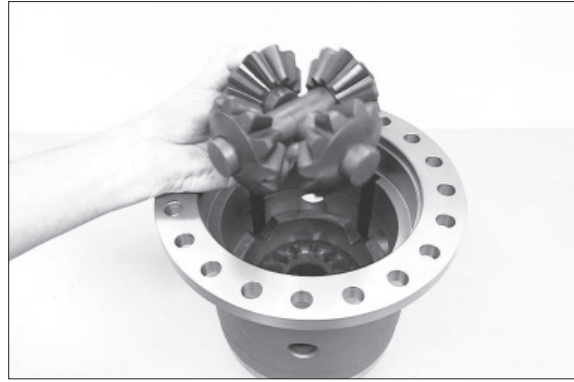

7577AAXF138

- ③ Put on the second axle bevel gear.

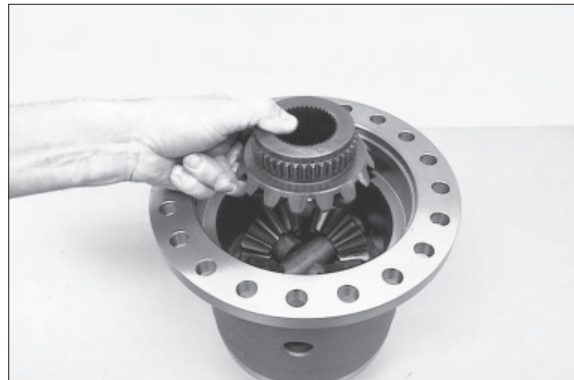

7577AAXF139

- ④ Insert the second pressure ring into the differential housing.

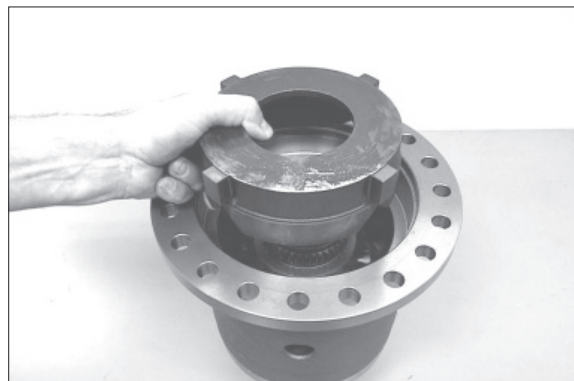

7577AAXF140

- ⑤ Starting with an inner clutch disc install alternately the inner and outer clutch discs.

- ▲ Thickness of the clutch disc pack must be identical on both sides.

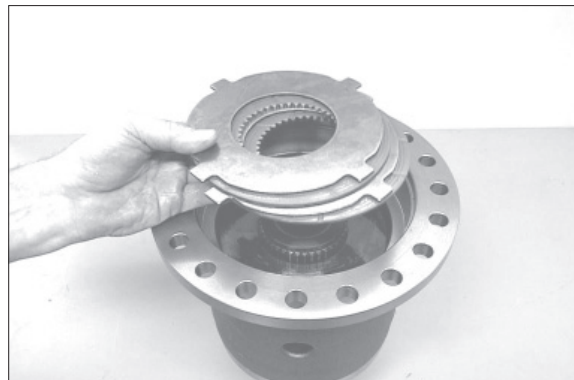

7577AAXF141

Determine disc clearance 0.2~0.8 mm

- ②⑥ Determine dimension I, from mounting face of the differential housing to plane face of the outer clutch disc.

Dimension I e.g 44.30 mm

※ Special tool

Digital depth gauge 5870 200 072

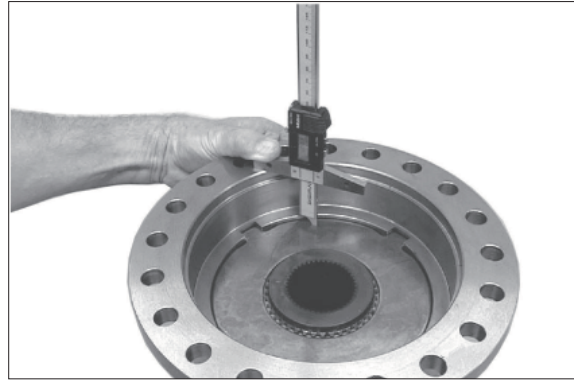

7577AAXF142

- ②⑦ Determine dimension II, from contact surface of the outer clutch disc to the mounting face of the housing cover.

Dimension II e.g 43.95 mm

EXAMPLE D :

Dimension I 44.30 mm

Dimension II - 43.95 mm

Difference = Disc clearance = 0.35 mm

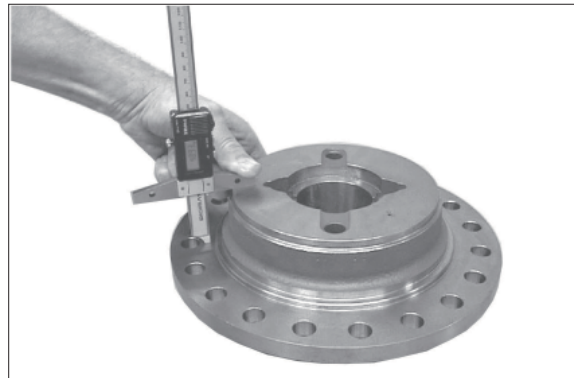

7577AAXF143

※ If the required disc clearance is not obtained, correct it with the adequate outer clutch discs (s = 2.7, s = 2.9, s = 3.0, s = 3.1 or s = 3.3 mm), taking care that the difference in thickness between the left and the right disc pack must only be 0.01 at a maximum.

- ②⑧ Fix both thrust washers with grease into the recess of the housing cover.

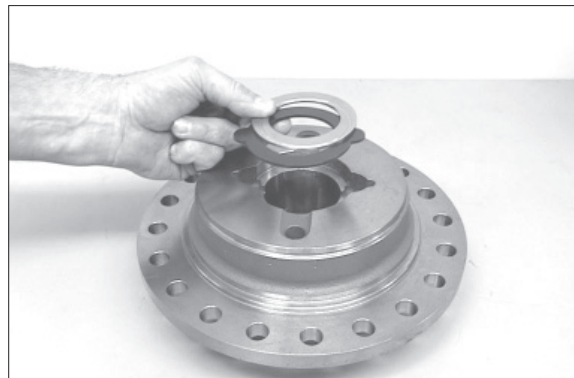

7577AAXF144

- ⑳ Put on the housing cover and fasten it by means of cap screws (2EA).
- Tightening torque (M10/8.8) :
4.7 kgf·m (33.9 lbf·ft)



7707AAXF015

- ㉑ Heat crown wheel and install it until contact.
- ※ Special tool
Adjusting screws 5870 204 040

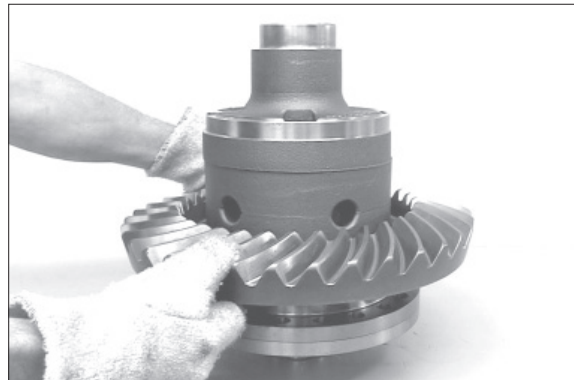

7577AAXF145

- ㉒ Fix differential by means of press and fasten crown wheel by means of new locking screws.
- Tightening torque : 41.8 kgf·m
(302 lbf·ft)
- ▲ Only use of new locking screws is permissible.**

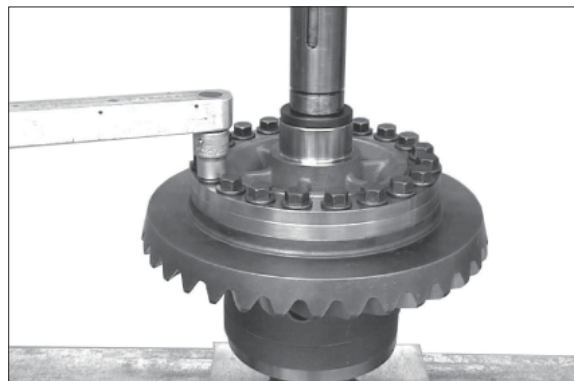

7577AAXF146

- ㉓ Press on both bearing outer rings until contact.

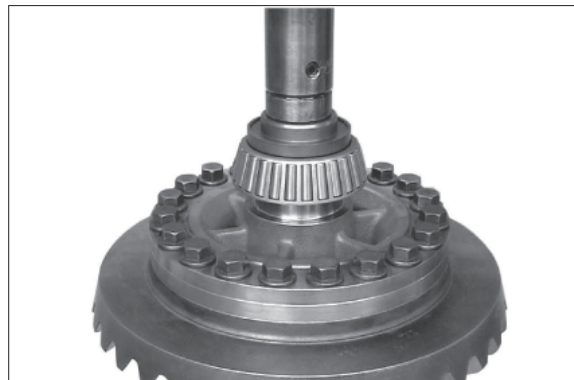

7577AAXF147

③ Insert differential into the axle drive housing by means of lifting tackle.

※ Special tool

Lifting tackle

5870 281 013

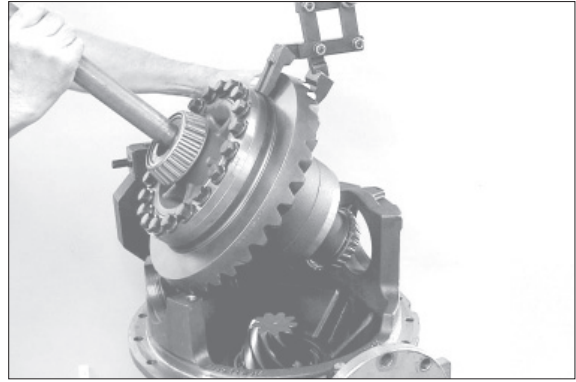

7577AAXF148

④ Place bearing outer ring into the axle drive housing.

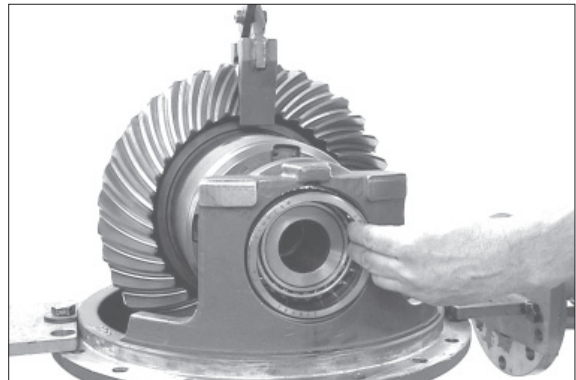

7577AAXF149

⑤ Preliminarily fix the bearing outer ring by means of adjusting nut.

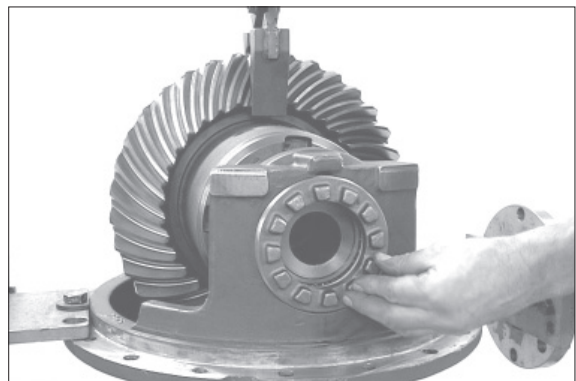

7577AAXF150

⑥ Install crown wheel-sided bearing outer ring.

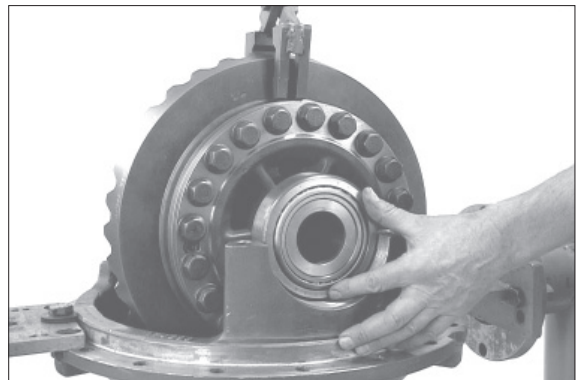

7577AAXF151

- ③⑦ Preliminarily fix the crown wheel-sided bearing outer ring by means of the second adjusting nut.

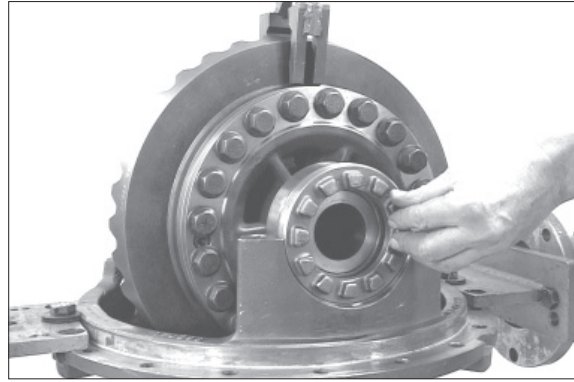

7577AAXF152

- ③⑧ Put on bearing bracket and fasten it by means of hexagon screws and washers.

- Tightening torque (M16/10.9) :
28.6 kgf·m (207 lbf·ft)

- ※ Pay attention to clearance of the adjusting nut.

▲ Apply loctite (type No. 262) onto threads of the hexagon screws.

Adjustment of backlash and bearing preload

- ③⑨ Place dial indicator right-angled at the outer diameter of the tooth flank (crown wheel).

Then install both adjusting nuts only to such an extent that the required backlash - see the value etched on the outer diameter of the crown wheel - is reached.

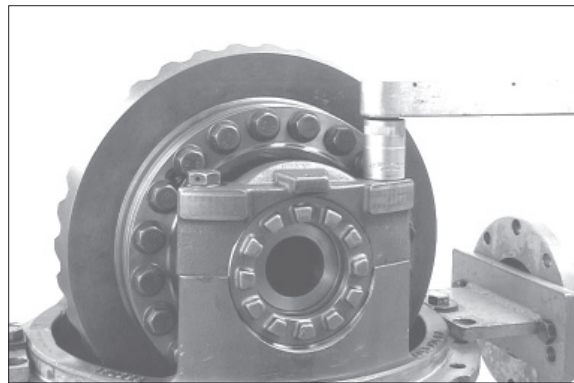

7577AAXF153

- ※ Special tool

Magnetic stand	5870 200 055
Dial indicator	5870 200 057
Socket spanner	5870 656 079

- ※ At this step rotate the differential several times.

- ④⑩ Determine bracket width and correct it on both adjusting nuts, if required.

Bracket width 418^{-0.05} mm

- ※ Special tool

Caliper gauge	5870 200 058
---------------	--------------

Then check backlash once again.

- ※ Adjusting of the bracket width results in the required bearing preload.

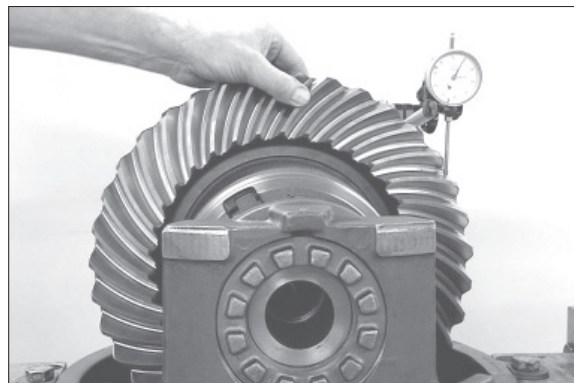

7577AAXF154

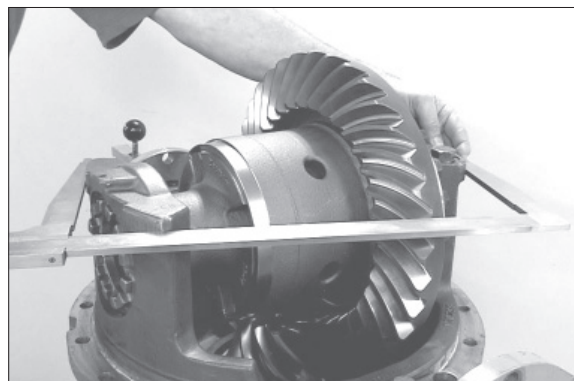

7577AAXF155

- ④① Cover some tooth flanks of the crown wheel with marking ink and roll crown wheel in both directions over the drive pinion.

Compare the obtained tooth contact pattern with the examples on page 3-179.

- ▲ If the tooth contact pattern differs, there has been a measuring error at determination of the shim (figure 7577AAXF121/page 3-167), what is imperative to be corrected.

- ④② Secure both adjusting nuts by means of slotted pins.

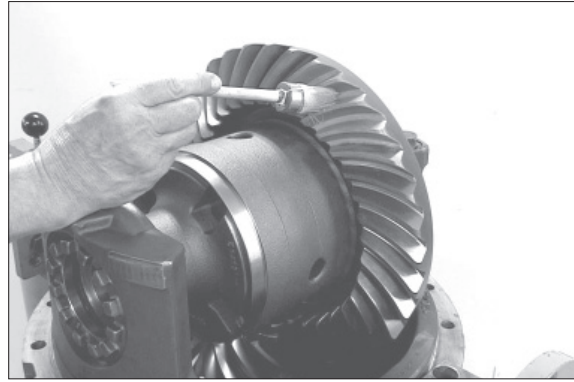

7577AAXF156

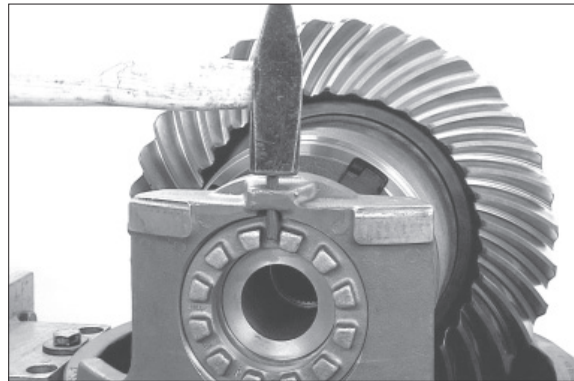

7577AAXF157

- ④③ Install two adjusting screws and insert differential carrier into the axle casing until contact by means of lifting tackle.

※ Special tool

Adjusting screws 5870 204 023

Lifting tackle 5870 281 044

※ Observe radial location (see marking page 3-155 / figure 7577AAXF081).

- ▲ Apply sealing compound (Three bond type 1215) on mounting face.

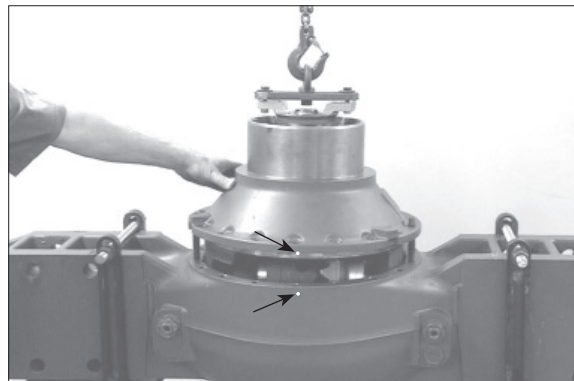

7577AAXF158

- ④④ Fasten differential carrier by means of new locking screws.

· Tightening torque : 25.5 kgf·m
(184 lbf·ft)

- ▲ Only use of the new locking screws is permissible.

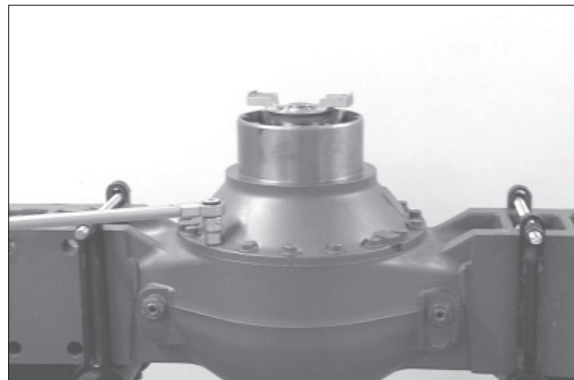

7577AAXF159

- ④⑤ Insert stub shaft into spline of the axle bevel gear until contact.

Then fix O-ring (see arrow) by means of grease into the recess of the axle casing.

- ※ Step (figure 7577AAXF160 ~ 163) is to be made on both output sides.

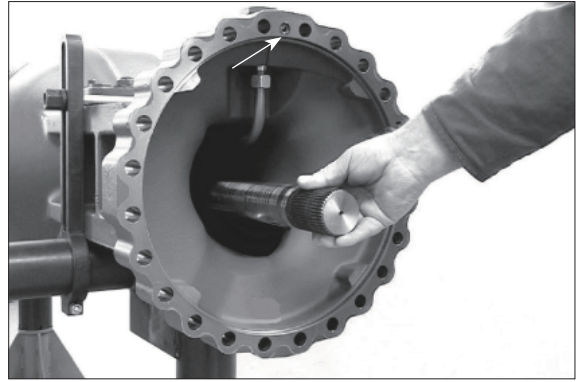

7577AAXF160

- ④⑥ Thrust washer (s) removed at disassembly have to be fixed in the sun gear shaft by means of grease.

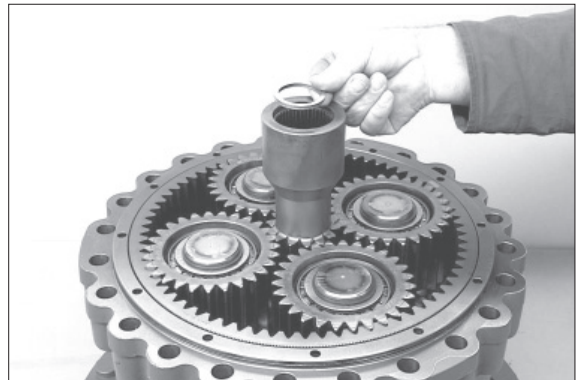

7577AAXF161

- ④⑦ Place complete output by means of lifting tackle to the axle casing until contact.

- ※ Special tool
Lifting bracket 5870 281 043

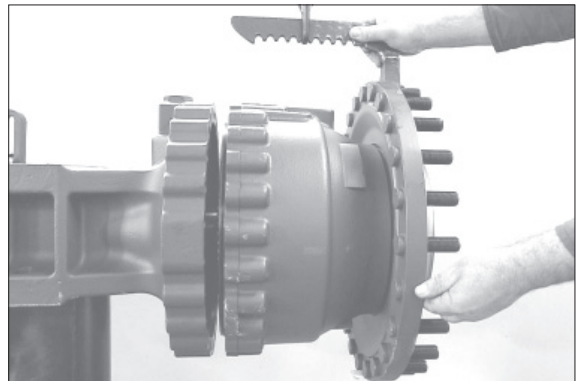

7577AAXF162

- ④⑧ Fasten output by means of hexagon screws and washers.

- Tightening torque (M18/10.9) :
39.8 kgf·m (288 lbf·ft)

- ※ Prior to putting into operation of the axle, fill oil in accordance with lubrication instructions.

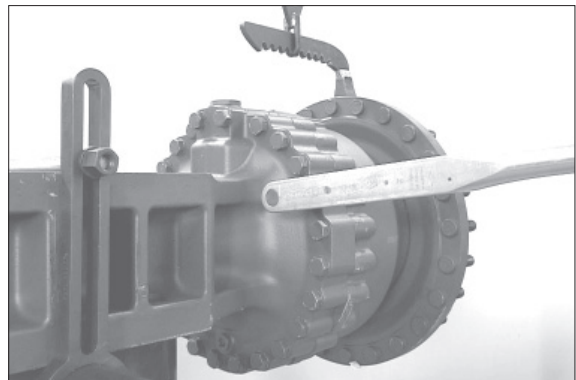

7577AAXF163

※ **BACKLASH CHECK**

- Applied the paint (or red lead) on the surface of several bevel gear teeth.
- Turn the pinion gear and check the contact pattern.

Correct pattern

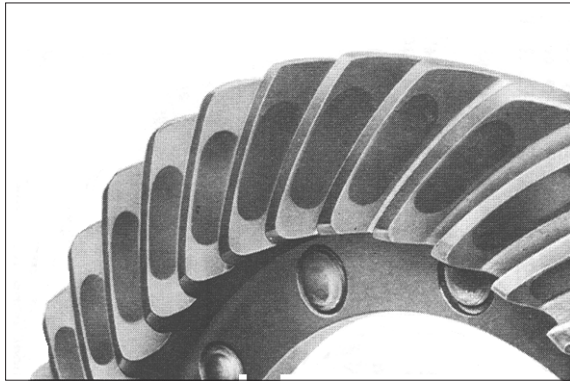

WTHAX16

Concave side



WTHAX17

Convex side

※ **ADJUSTMENT**

Incorrect pattern : high contact

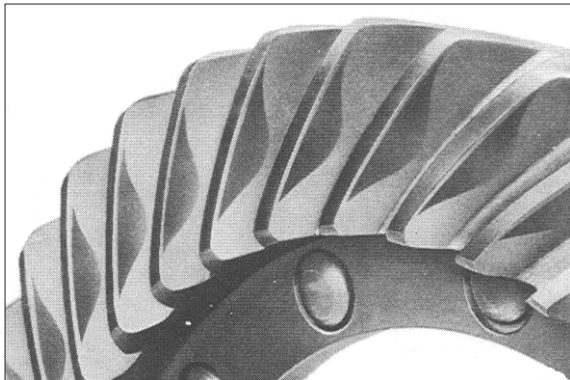

WTHAX18

Concave side

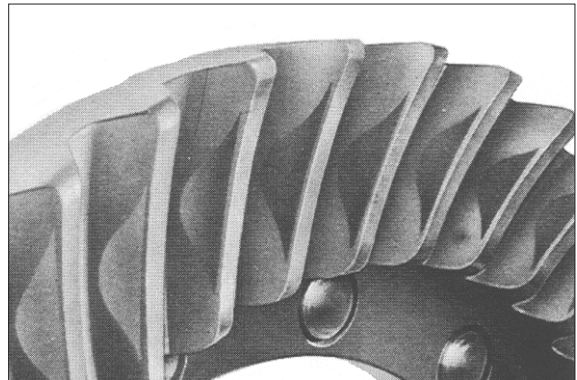

WTHAX19

Convex side

- Reduce the distance (-)

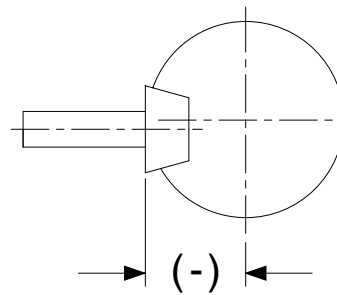

WTHAX20

Incorrect pattern, low contact

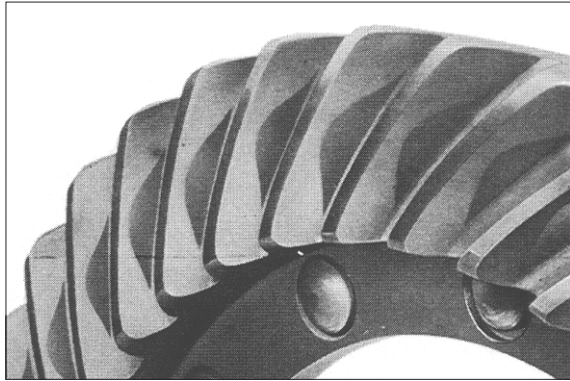

WTHAX21

Concave side

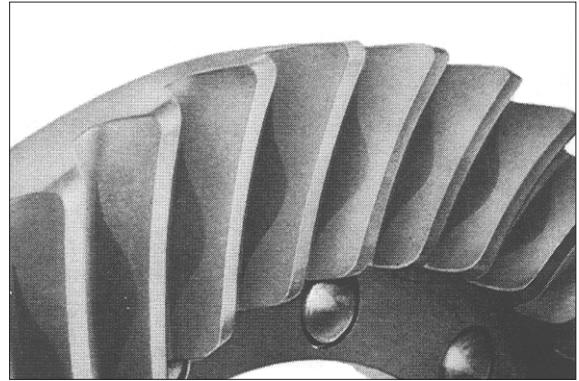

WTHAX22

Convex side

- Add the distance (+)

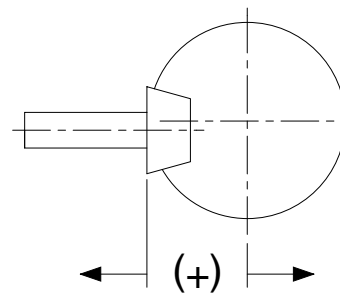

WTHAX23

• REAR AXLE

1) DISASSEMBLY OF OUTPUT AND BRAKE

(1) Fasten axle on assembly truck.

※ Special tool

Assembly truck 5870 350 000

Holding fixtures 5870 350 077

Clamps 5870 350 075

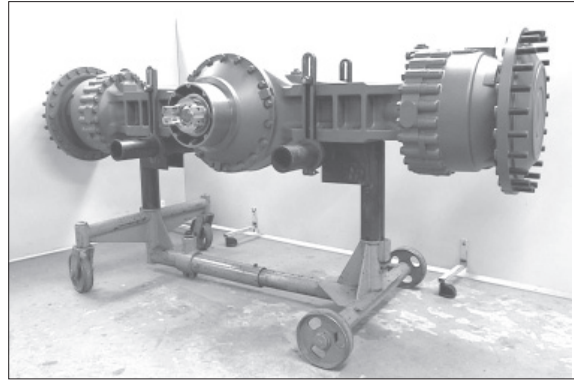

7577AAXF001

(2) Loosen screw plugs (3EA, see Figure 7577AAXF002 and 003) and drain oil from axle casing.

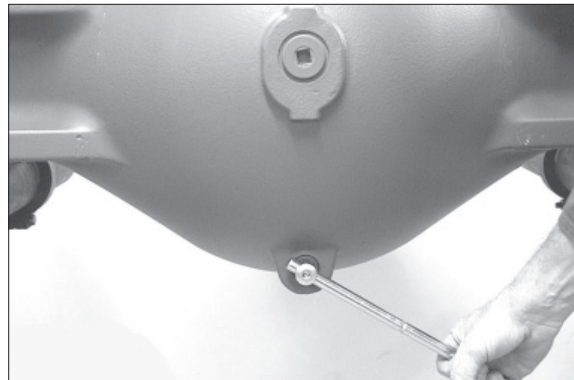

7577AAXF002

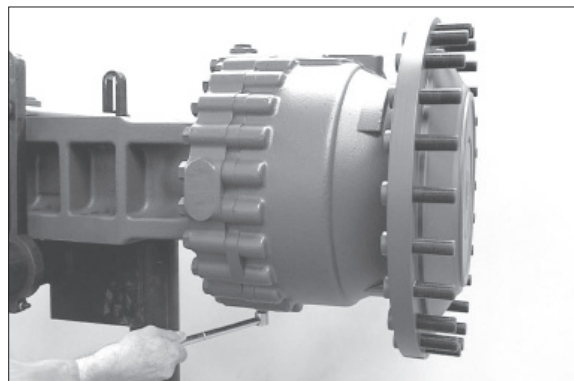

7577AAXF003

(3) Press off cover from the output shaft.

※ Special tool

Pry bar set 5870 345 065

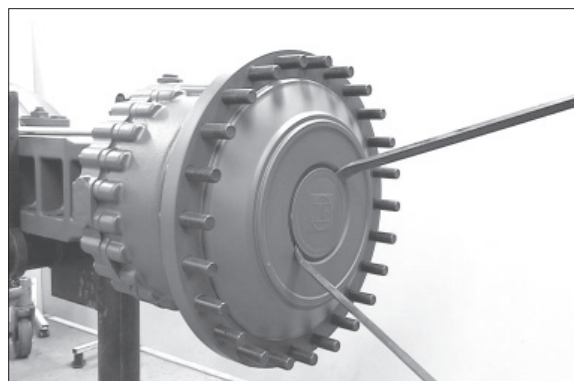

7577AAXF004

(4) Pull slotted pin by means of the striker out of the bore in the slotted nut.

- ※ Special tool
Striker 5870 650 001

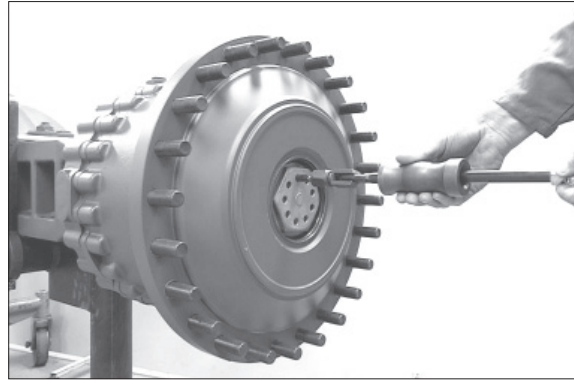

7577AAXF005

(5) Loosen slotted nut.

- ※ Special tool
Socket spanner 5870 656 077
Centering bracket 5870 912 028

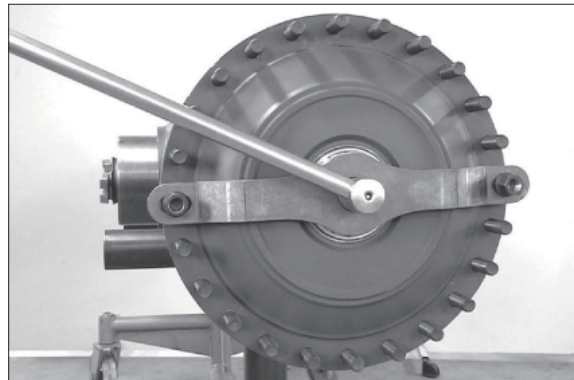

7577AAXF006

(6) Secure output by means of lifting tackle and loosen hexagon screws.

- ※ Special tool
Lifting bracket 5870 281 043

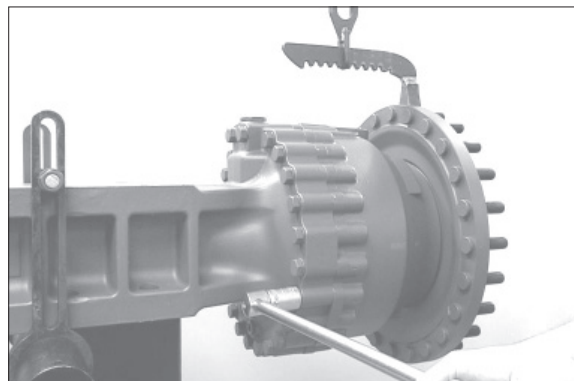

7577AAXF007

(7) Separate complete output from the axle casing.

- ※ Pay attention to released O-ring (see arrow).

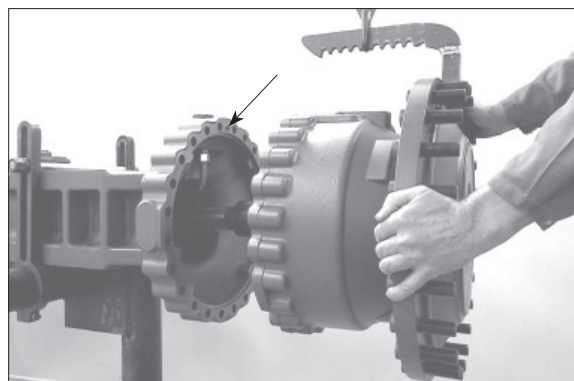

7577AAXF008

- (8) Pull stub shaft out of the sun gear shaft.
※ Pay attention to possibly released shim (s).

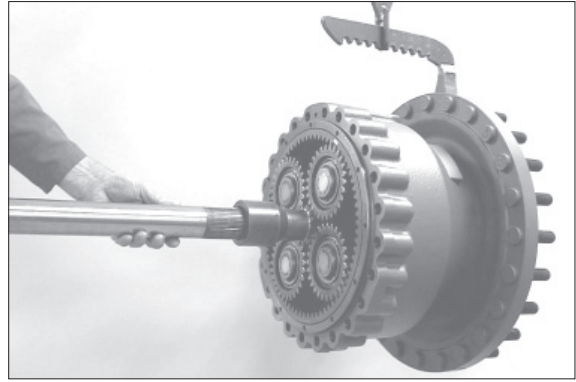

7577AAXF009

- (9) Remove shim (s) from the sun gear shaft.

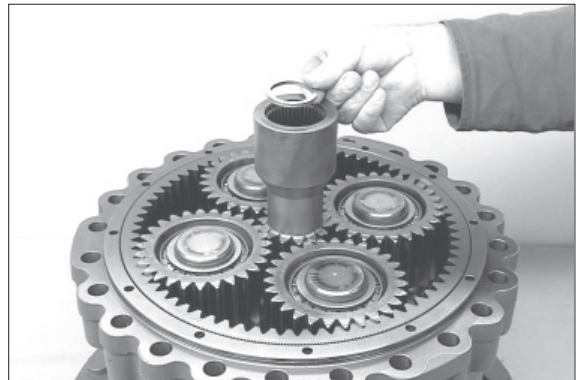

7577AAXF010

- (10) Pull sun gear shaft out of the planet gears.

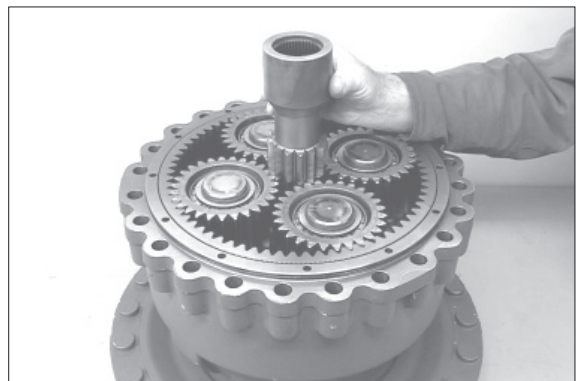

7577AAXF011

- (11) Lift planet carrier out of the brake housing.

- ※ Special tool
Internal extractor 5870 300 019



7577AAXF012

(12) Squeeze out the retaining ring.

- ※ Special tool
Set of external pliers 5870 900 015

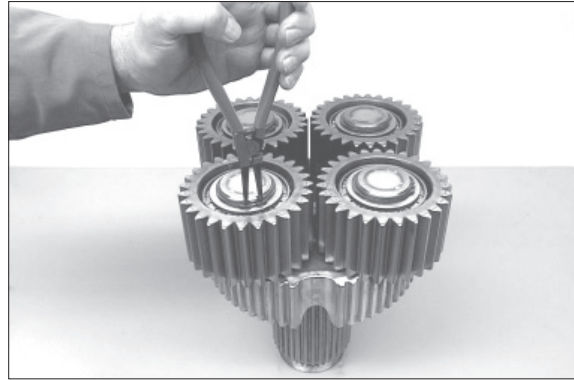

7577AAXF013

(13) Pull off the planet gear and remove the released bearing inner ring.

- ※ Special tool
Three-armed puller 5873 971 002



7577AAXF014

(14) Pull off the bearing inner ring.

- ※ Special tool
Gripping insert 5873 001 020
Back-off insert 5873 026 100

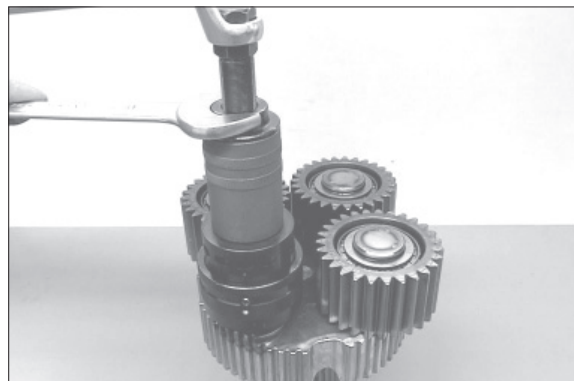

7577AAXF015

(15) Separate ring gear from the brake housing by means of two-armed puller.

- ※ Special tool
Two-armed puller 5870 970 007

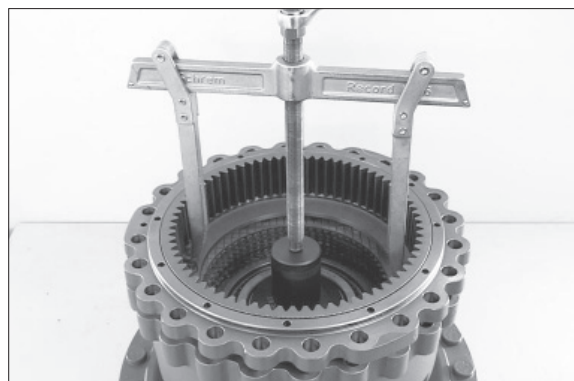

7577AAXF016

(16) Remove O-rings (see arrows) from the annular grooves of the ring gear.

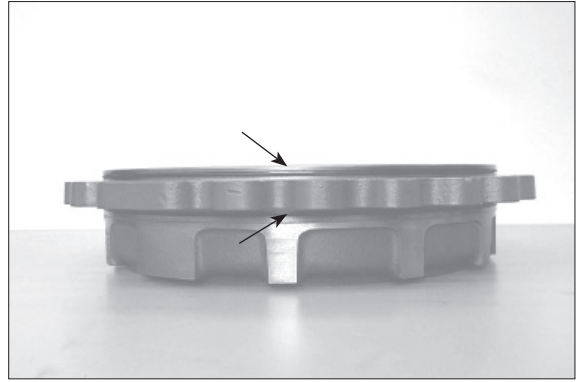

7577AAXF017

(17) Remove O-ring (see arrow) from the recess of the brake housing.

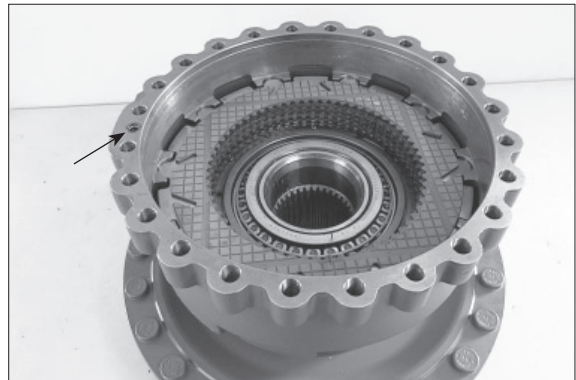

7577AAXF018

(18) Take the disc pack out of the brake housing.

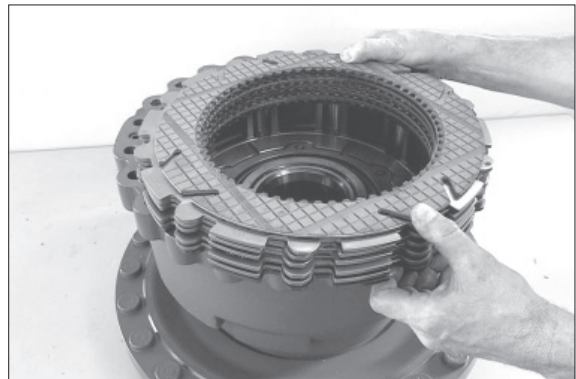

7577AAXF019

(19) Install slotted pins (6EA) in the support shim until they are flush-mounted.

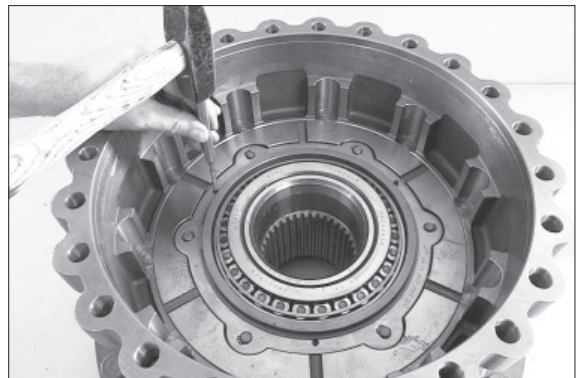

7577AAXF020

(20) Squeeze out the circlip.

※ Special tool

Set of external pliers

5870 900 016

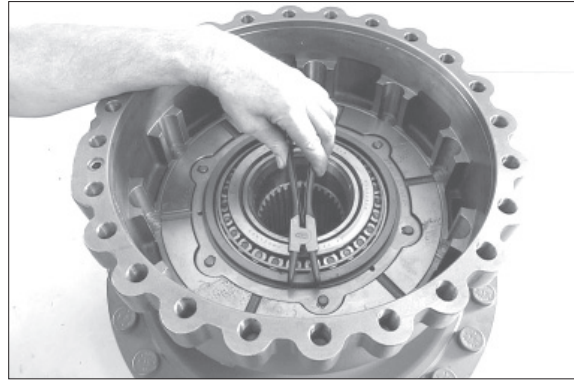

7577AAXF021

(21) Press piston out of the brake housing by means of compressed air.

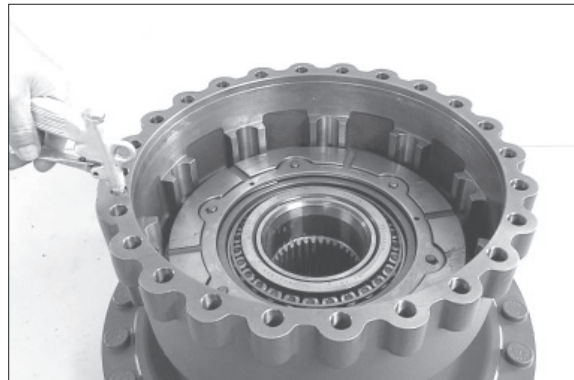

7577AAXF022

(22) Press support shim out of the piston by means of the automatic piston adjusting.

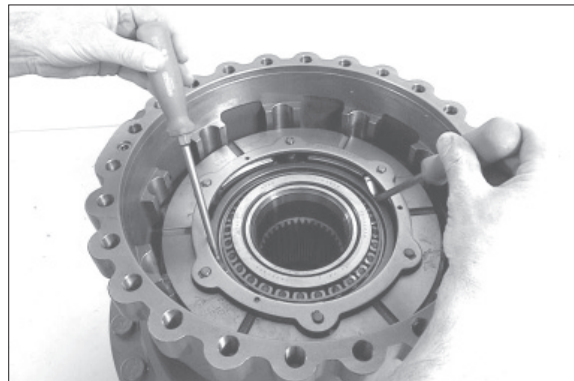

7577AAXF023

(23) Drive slotted pins (6EA) out of the support shim.

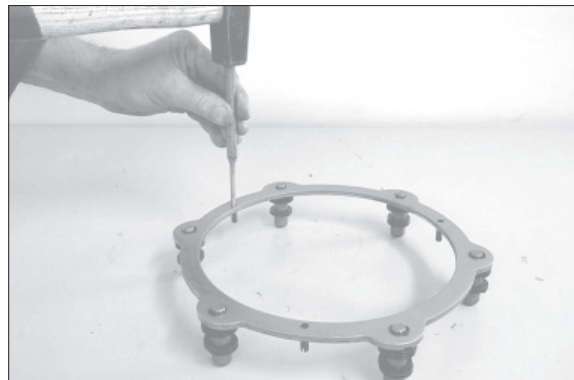

7577AAXF024

(24) Preload cup springs by means of a press and squeeze out the circlip.

※ Special tool

Assembly pliers 5870 900 051

Assembly fixture 5870 345 096

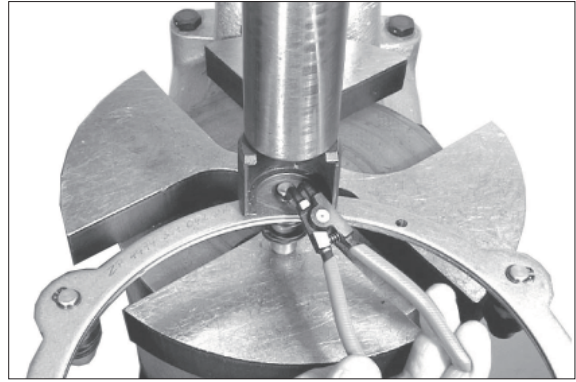

7577AAXF025

(25) Pull pin out of the support shim and remove released cup springs.



7577AAXF026

(26) Press gripping rings from the pin.

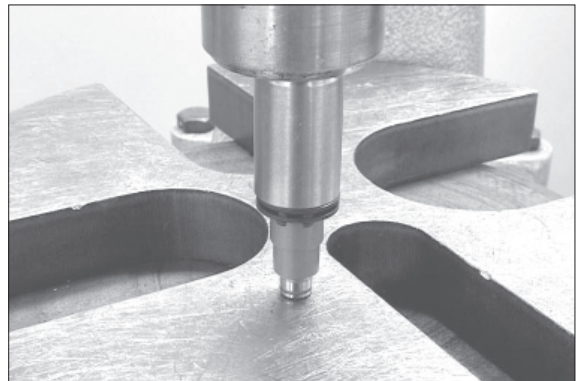

7577AAXF027

(27) Lift piston out of the brake housing.

※ Special tool

Adjusting device 5870 400 001

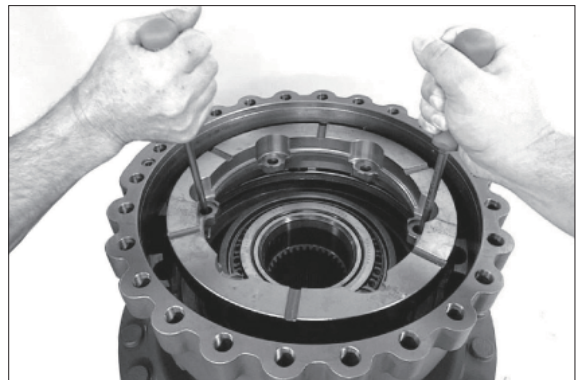

7577AAXF028

(28) Remove guide ring, support rings and U-rings from the annular grooves of the brake housing.

※ See below sketch for installation position of the single parts.

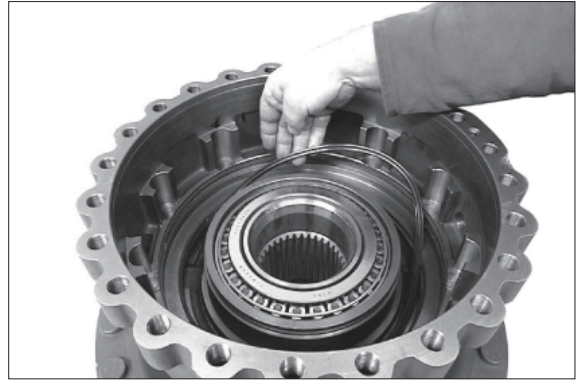

7577AAXF029

To the sketch :

- 1 Brake housing
- 2 Guide ring
- 3 Support ring
- 4 U-ring
- 5 U-ring
- 6 Support ring
- 7 Output shaft

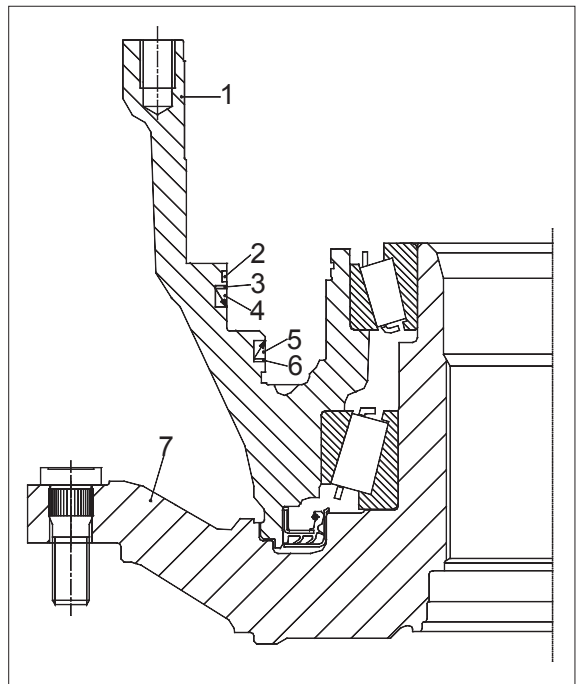

7577AAXF030

(29) Pull brake housing by means of two-armed puller from the output shaft and remove the released bearing inner ring.

※ Special tool

- | | |
|------------------|--------------|
| Two-armed puller | 5870 970 007 |
| Clamping bracket | 5870 654 034 |
| Press bush | 5870 506 140 |

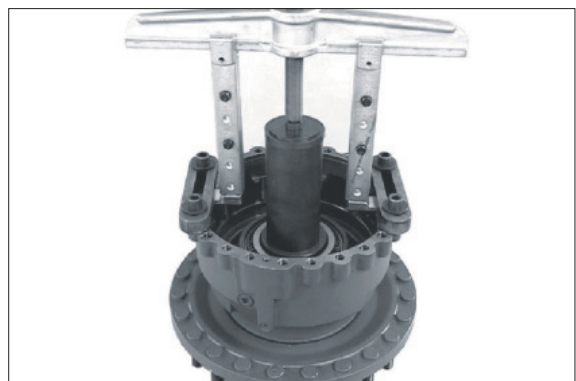

7577AAXF031

(30) Lift brake housing with lifting tackle from the output shaft.

- ※ Special tool
- Lifting chain 5870 281 047
- Eye bolts 5870 204 071

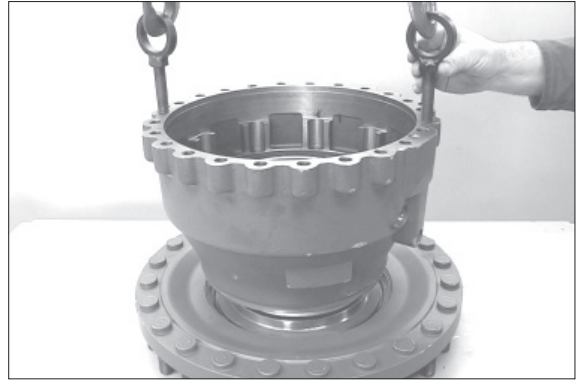

7577AAXF032

(31) If necessary drive both bearing outer rings out of the bearing bores in the brake housing.



7577AAXF033

(32) Press shaft seal out of the brake housing.

- ※ Special tool
- Pry bar set 5870 345 065



7577AAXF034

(33) Pull bearing inner ring from the output shaft.

- ※ Special tool
- Rapid grip 5873 014 017
- Basic set 5873 004 001

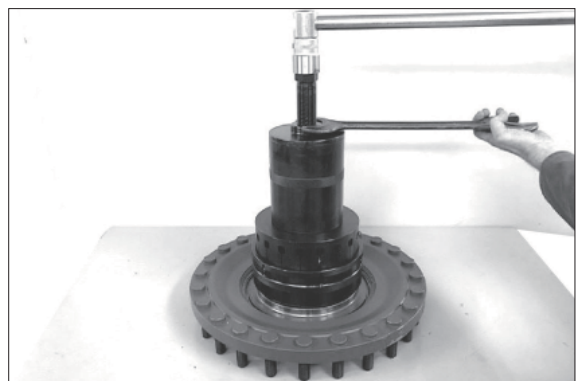

7577AAXF035

(34) Press off bearing sheet from the output shaft.

※ Special tool
Pry bar set

5870 345 065

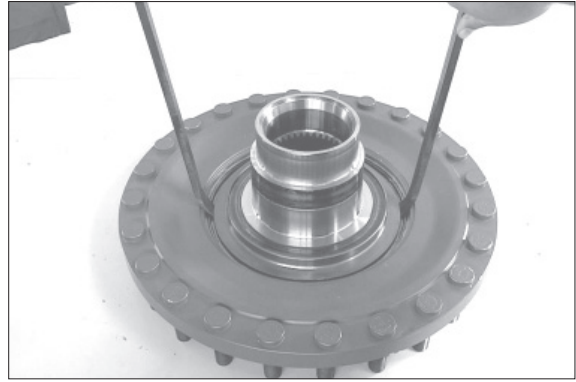

7577AAXF036

2) REASSEMBLY OF OUTPUT AND BRAKE

(1) Insert wheel bolt into the output shaft until contact.

※ Special tool

Wheel bolt puller-basic set 5870 610 010

Insert (3/4"-16 UNF) 5870 610 005

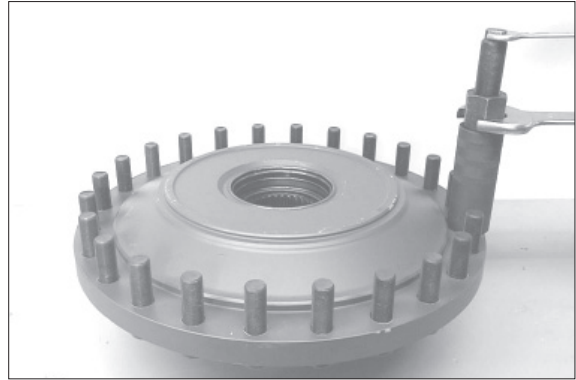

7577AAXF037

(2) Assemble bearing sheet (shaft seal).

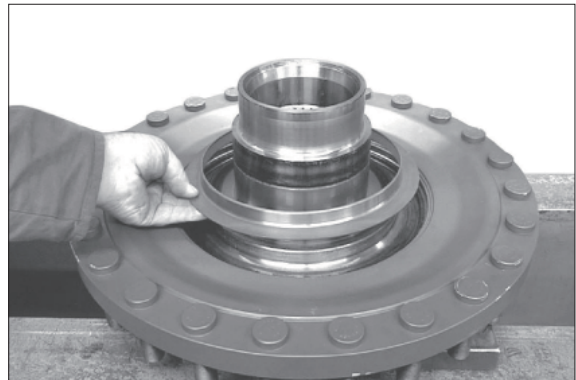

7577AAXF038

(3) Press bearing sheet over the collar of the output shaft.

※ Special tool

Pressure ring 5870 506 141

※ The exact installation position of the bearing sheet will be obtained by using the specified pressure ring.

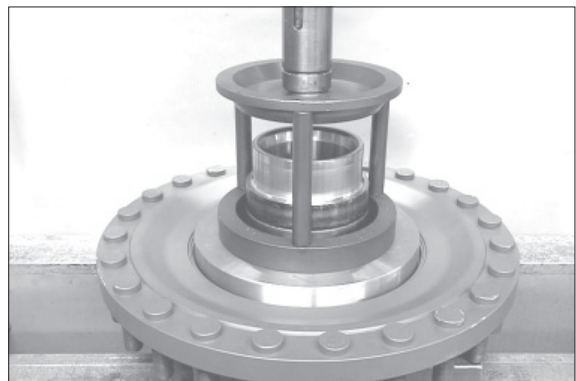

7577AAXF039

(4) Heat the roller bearing and install it until contact.

※ After cooling-down the bearing has to be installed subsequently.



7577AAXF040

- (5) Press both bearing outer rings into the brake housing until contact.

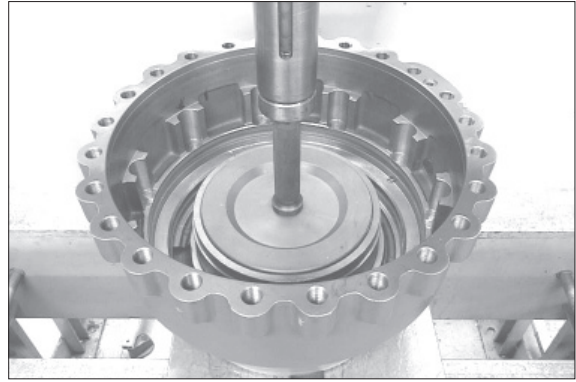

7577AAXF041

- (6) Install shaft seal with the sealing lip showing to the oil chamber (see below sketch).

- ※ Special tool
Driver 5870 051 052
- ※ The exact installation position of the shaft seal will be obtained by using the specified driver.

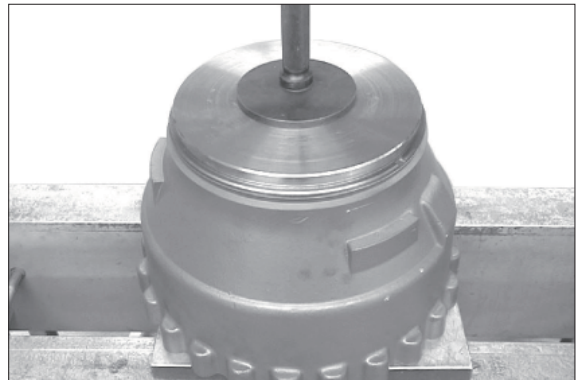

7577AAXF042

- ▲ **Just before the installation wet the outer diameter of the shaft seal with spirit.**

To the sketch :

- 1 Brake housing
- 2 Shaft seal
- * Grease filling

- ※ Fill the space between sealing and dust lips with grease.

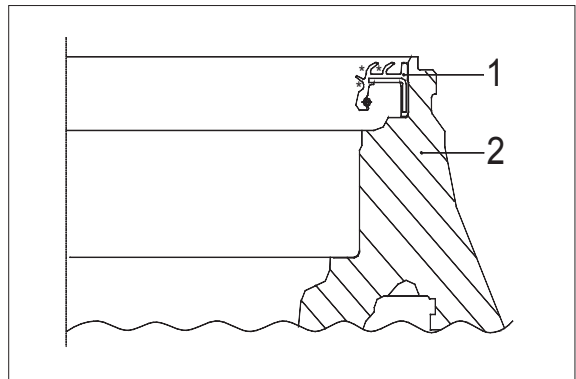

7577AAXF043

- (7) Install the preassembled brake housing by means of the lifting tackle over the output shaft until contact.

- ※ Special tool
Lifting chain 5870 281 047
Eye bolts 5870 204 071

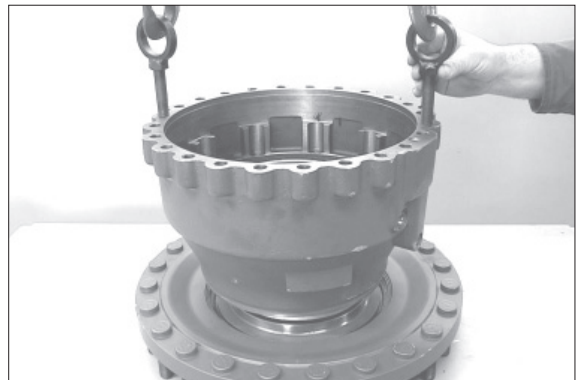

7577AAXF044

(8) Heat the roller bearing and install it until contact.



7577AAXF045

(9) Insert support and U- rings into the annular grooves of the brake housing.

※ Pay attention to the installation position, see below sketch.

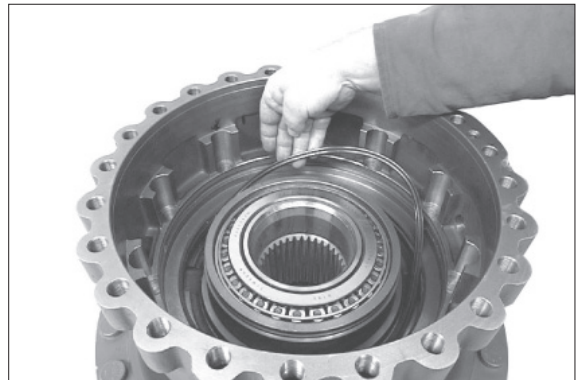

7577AAXF046

To the sketch :

- 1 Brake housing
- 2 Guide ring
- 3 Support ring
- 4 U-ring
- 5 U-ring
- 6 Support ring
- 7 Output shaft

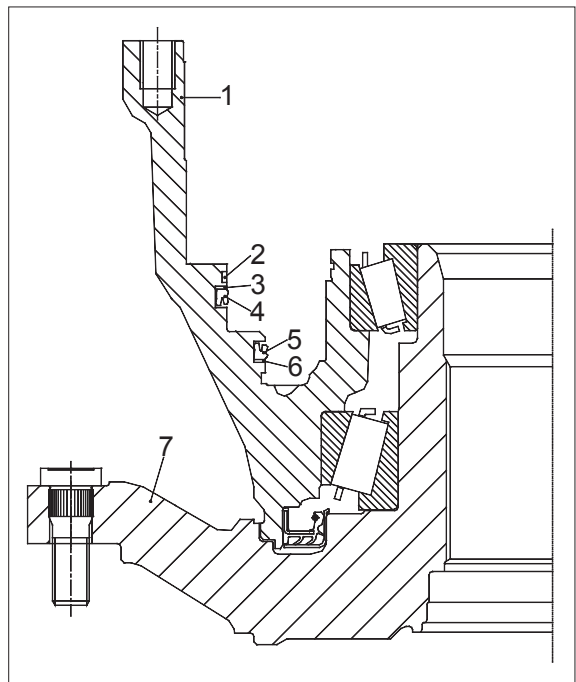

7577AAXF047

(10) Clean annular groove of the brake housing with spirit.

Then insert the guide ring into the annular groove (also see sketch page 3-193) and fix it with Loctite (type No. 415) at its extremities.

※ Guide ring must have contact on the whole circumference.

▲ Upon installation the orifice of the guide ring must show upwards (12 o'clock).

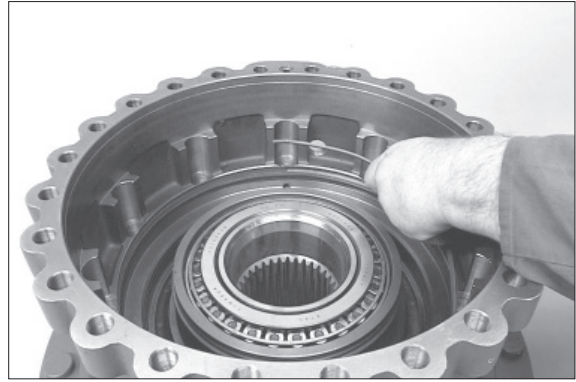

7577AAXF048

(11) Insert piston into the brake housing and install it cautiously until contact.

※ Apply sufficiently oil on the sliding surface of the piston or support rings, U-rings and guide ring (use W-10 oils).

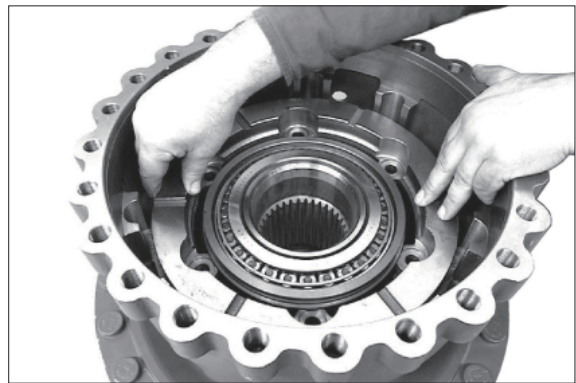

7577AAXF049

(12) Insert pins into the assembly fixture until contact.

※ Special tool

Assembly fixture 5870 345 096

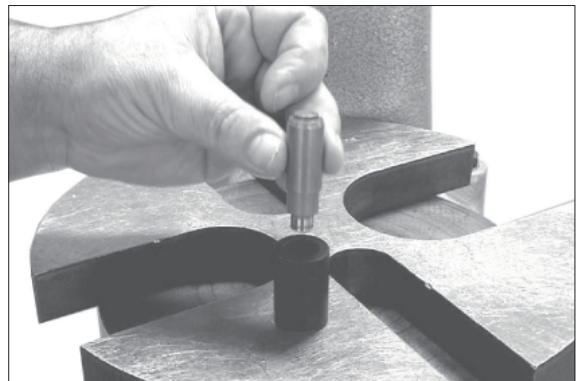

7577AAXF050

(13) Press gripping rings (4EA, see arrows) onto the pins until contact on the assembly fixture.

※ The exact installation dimension (see sketch page 3-195) of the gripping rings is obtained when using the specified assembly fixture.

▲ Observe the installation position, install gripping rings with the orifices offset by 180° to each other.

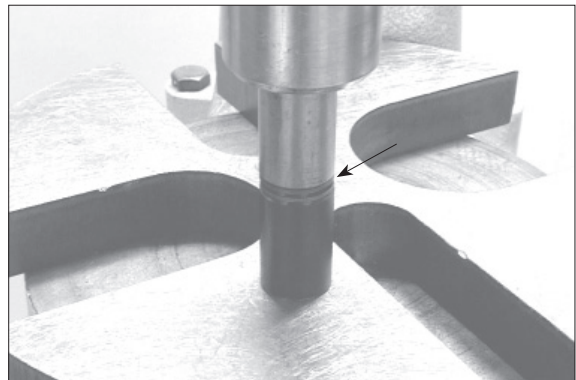

7577AAXF051

(14) Install cup springs (7 pieces each/pin).

- ※ Pay attention to the installation position of the cup springs, see below sketch.



7577AAXF052

To the sketch :

- 1 Pin
- 2 Gripping rings
- 3 Cup springs
- 4 Support shim
- 5 Circlip
- X Installation dimension gripping rings
 10.5 ± 0.3 mm

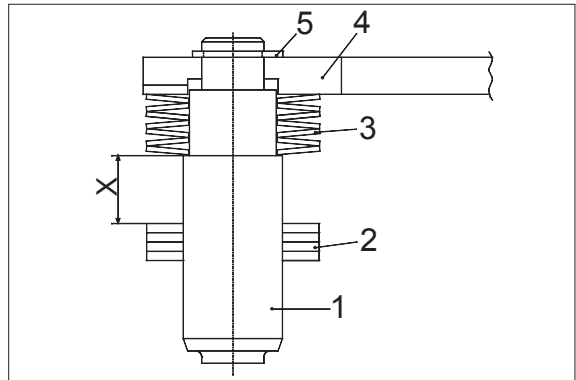

7577AAXF053

(15) Insert preassembled pins into the support shim and fix it by means of the circlip.

- ※ Special tool
Assembly pliers 5870 900 051
- ※ Pay attention to clearance of the cup springs.

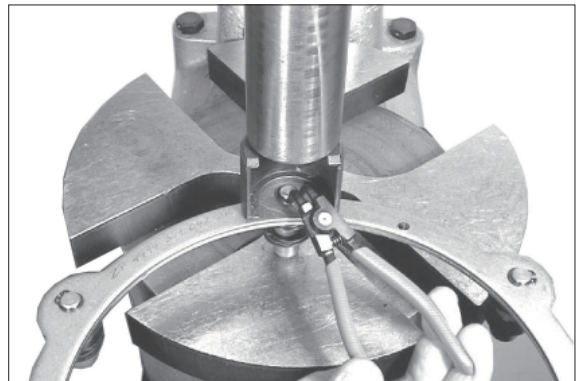

7577AAXF054

(16) Insert preassembled support shim into the piston.

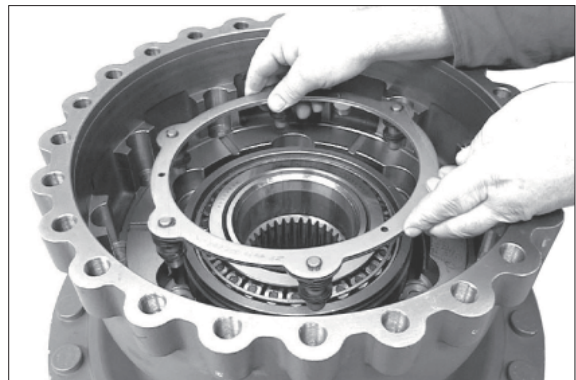

7577AAXF055

(17) Fix support shim by means of the circlip.

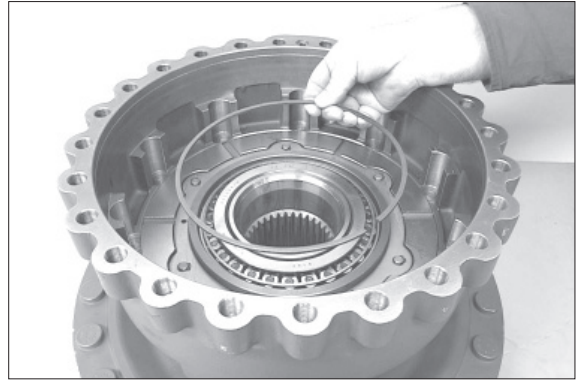

7577AAXF056

(18) Drive slotted pins (6EA) into the bores of the support shim to lock the circlip.

- ※ Special tool
Drive mandrel 5870 705 011
- ※ Pay attention to the installation position, see below sketch.

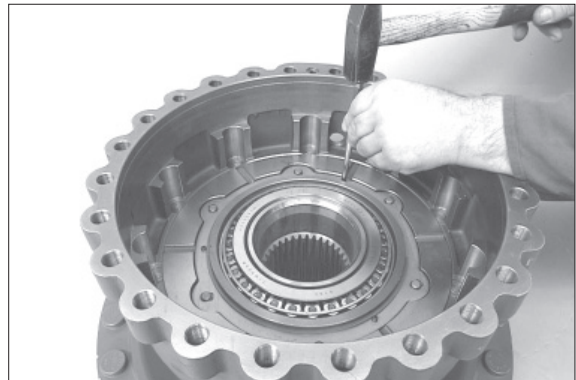

7577AAXF057

To the sketch :

- 1 Brake housing
- 2 Circlip
- 3 Slotted pin
- 4 Support shim
- 5 Piston
- X Installation dimension $4.0_{-0,5}$ mm

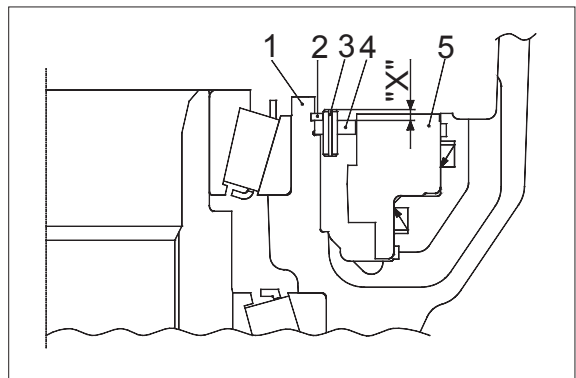

7577AAXF058

(19) Drive stop bolt into the planet carrier until contact.

Then wet spline (see arrow).

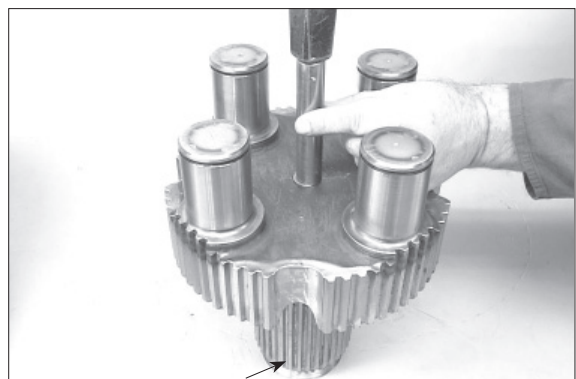

7577AAXF059

(20) Insert planet carrier into the spline of the output shaft until contact.

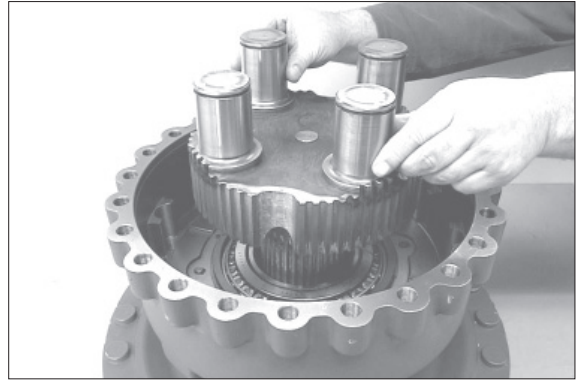

7577AAXF060

(21) Install outer- and inner clutch discs alternately starting with an outer clutch disc.

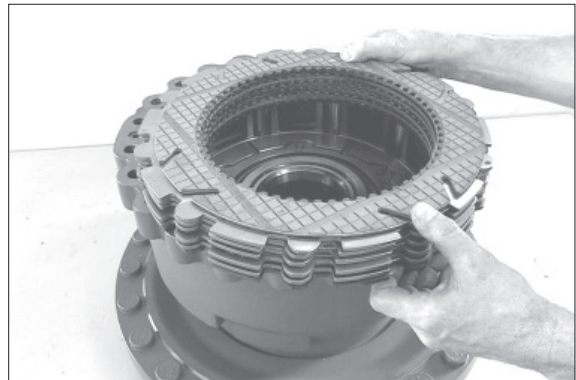

7577AAXF061

(22) Insert O-ring (see arrow) into the recess of the brake housing.

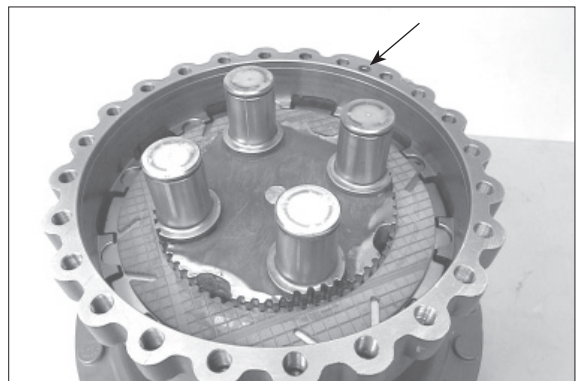

7577AAXF062

(23) Grease both O-rings (see arrows) and insert them into the annular grooves of the ring gear.

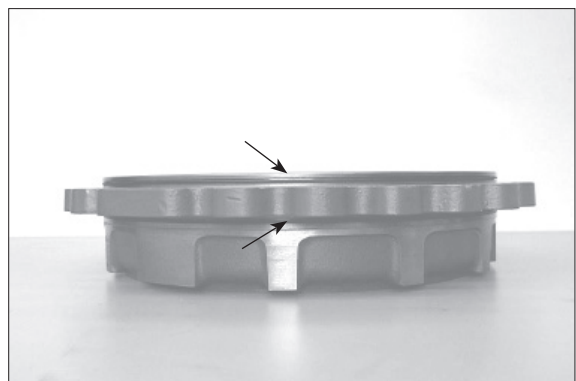

7577AAXF017

(24) Install two adjusting screws and insert ring gear into the brake housing until contact.

※ Special tool

Adjusting screws 5870 204 029

※ Pay attention to radial location.

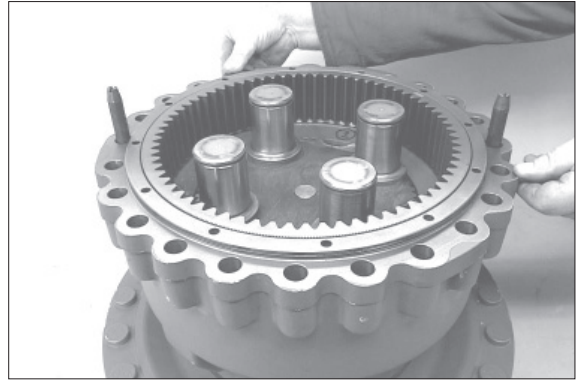

7577AAXF063

(25) Heat bearing inner rings and install them until contact with the big radius showing to the planet carrier (downwards).

※ Subsequently install bearing inner rings after cooling down.

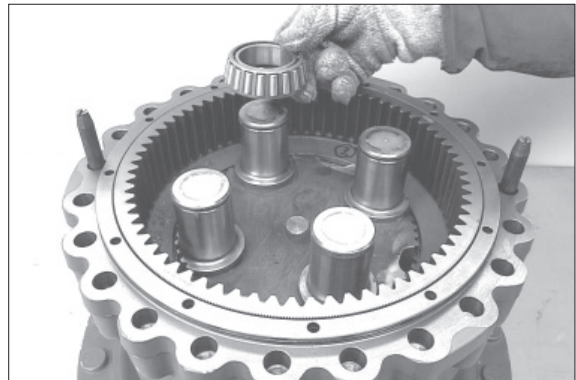

7577AAXF064

(26) Put planet gears onto the bearing inner rings.

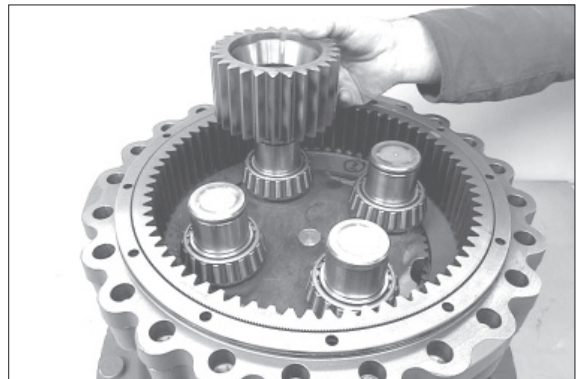

7577AAXF065

(27) Heat bearing inner rings and install them on the planet gears until contact.

※ Subsequently install bearing inner rings after cooling down.

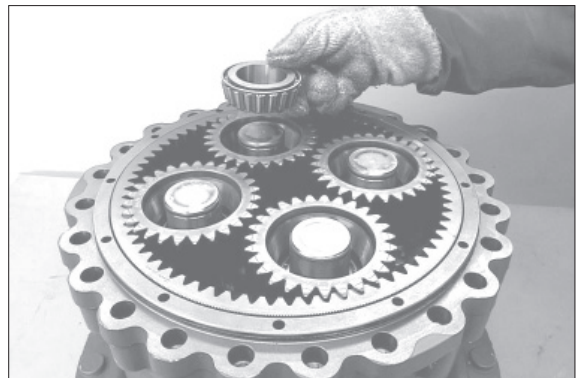

7577AAXF066

(28) Fasten plant gears by means of retaining rings.

- ※ Special tool
- Set of external pliers 5870 900 015



7577AAXF067

Adjust end play of sun gear shaft 0.5 ~ 2.0 mm

(29) Fasten ring gear by means of cap screws until contact.

Then determine dimension I, from the mounting face of the ring gear up to the face of the stop bolt.

Dimension I e.g 46.20 mm

- ※ Special tool
- Digital depth gauge 5870 200 072
- Gauge blocks 5870 200 066
- Straightedge 5870 200 022

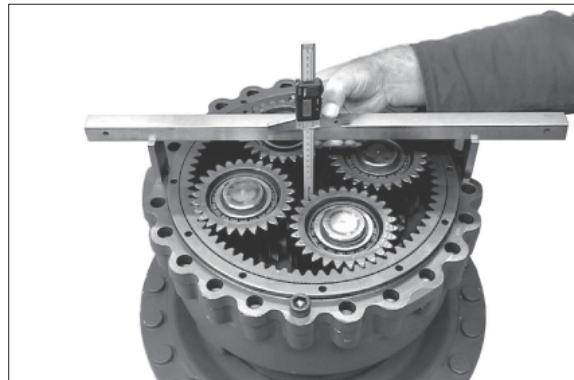

7577AAXF068

(30) Insert stub shaft into spline of the axle bevel gear until contact.

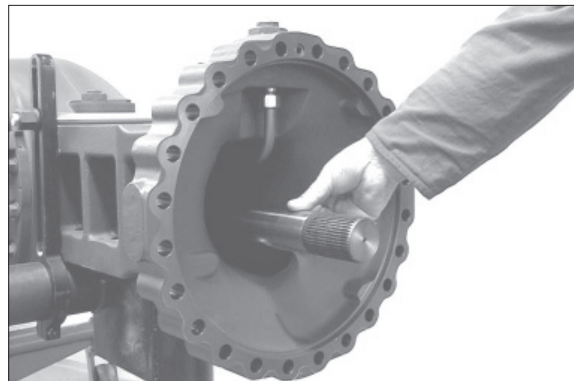

7577AAXF069

(31) Assemble sun gear shaft until contact.

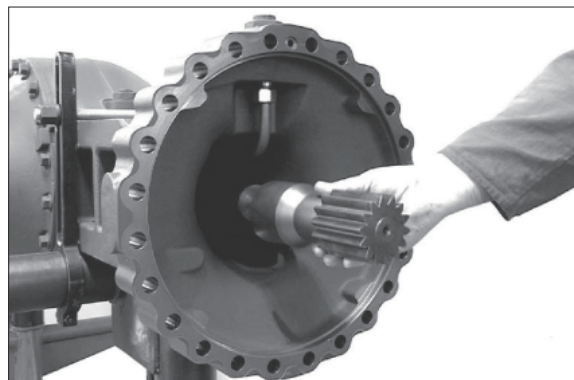

7577AAXF070

(32) Determine Dimension II from the face of the sun gear shaft up to the mounting face of the axle casing.

Dimension II e.g. 43.00 mm

※ Special tool

Digital depth gauge 5870 200 072

Gauge blocks 5870 200 066

Straightedge 5870 200 022

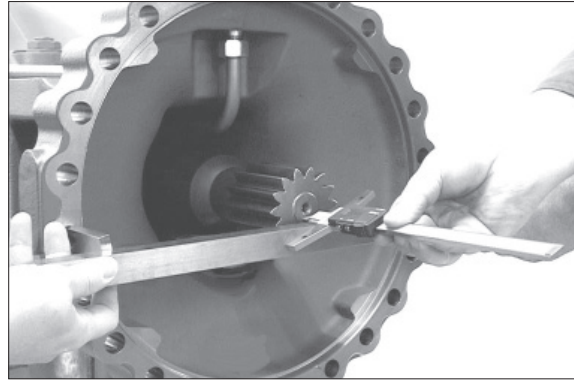

7577AAXF071

EXAMPLE A :

Dimension I 46.20 mm

Dimension II - 43.00 mm

Difference 3.20 mm

required end play e.g. - 1.00 mm

Difference = shim e.g. $s = 2.20$ mm

(33) Insert sun gear shaft into the planet carrier.

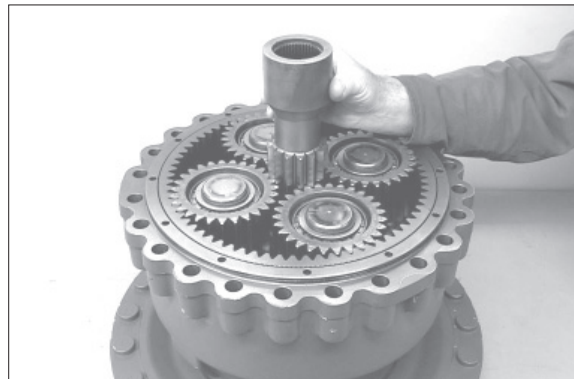

7577AAXF072

(34) Fix determined shim(s), e.g. $s = 2.20$ mm, into the sun gear shaft by means of grease.

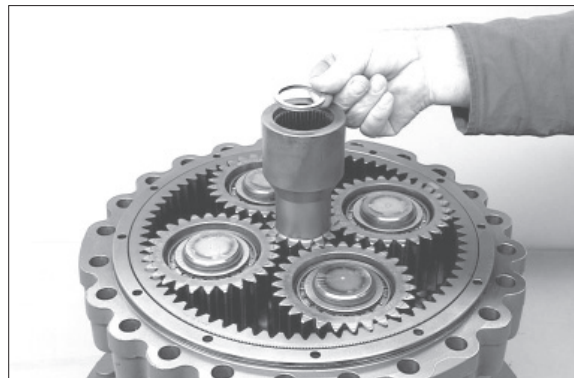

7577AAXF073

(35) Fix O-ring(see arrow) into the recess of the axle casing by means of grease and install the preassembled output to the axle casing until contact by means of lifting tackle.

※ Special tool

Lifting bracket 5870 281 043

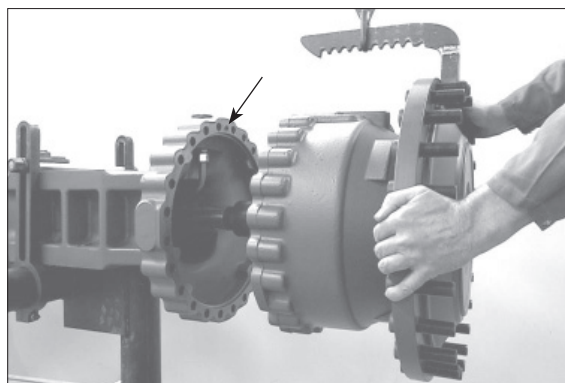

7577AAXF074

(36) Fasten output by means of hexagon screws and washers.

· Tightening torque (M18/10.9) :

39.8 kgf · m (288 lbf · ft)

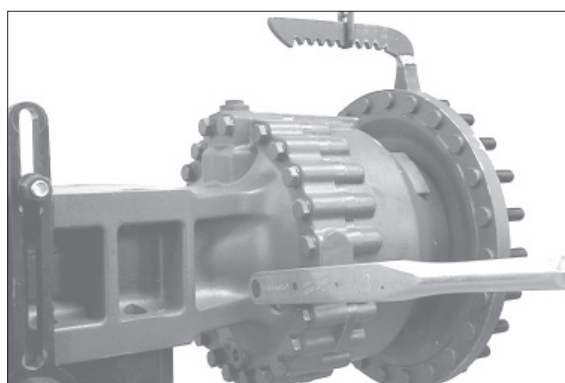

7577AAXF075

(37) Unscrew slotted nut by hand and then fasten it.

· Tightening torque : $71.4^{+30.6}$ kgf · m
(516^{+221} lbf · ft)

※ Special tool

Socket spanner 5870 656 077

Centering bracket 5870 912 028

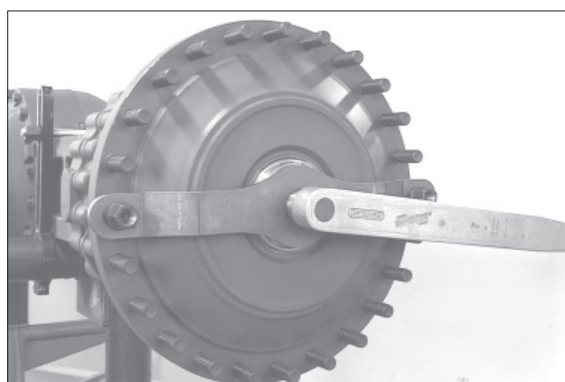

7577AAXF076

(38) Secure slotted nut by means of slotted pin.



7577AAXF077

(39) Assemble O-ring (see arrow) to the cover.



7577AAXF078

(40) Insert cover into the output shaft until contact.

- ※ Special tool
Hammer (plastic \varnothing 60) 5870 280 004



7577AAXF079

Leakage test of the brake hydraulics

- ※ Prior to start the test, ventilate the brake hydraulics completely.

- 1) Open the bleeder.
- 2) Slowly actuate the HP-pump until oil flows out of the bleeder.
- 3) Close the bleeder again.
- 4) Slowly pressurize the HP-pump with $p > 10$ bar and hold the pressure for some seconds.

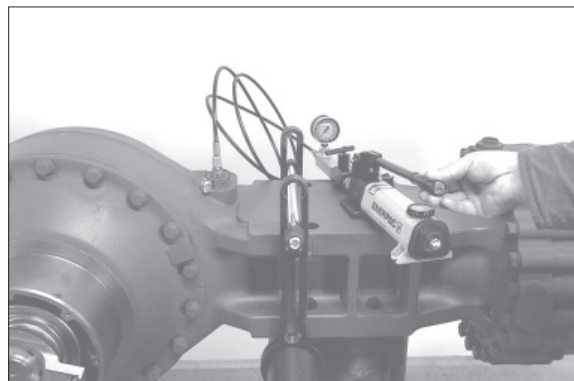

7577AAXF080

- ※ The brake piston extends and the cylinder chamber fills up with oil. The air accumulates in the upper section of the cylinder chamber.
- 5) Loosen the shut-off valve on the HP-pump.
 - ※ The reversing piston presses the air from the upper section of the cylinder into the brake line.
 - 6) Open the bleeder again.
 - 7) Slowly actuate the HP-pump until oil flows out of the bleeder.
- ※ Repeat procedure - Item 3)~7) until at 7) from the beginning of the actuation no more air exits from bleeder.
 - ※ Then pressurize the brake temporarily (5EA) with $p = 100$ bar max..

High-pressure test :

Increase test pressure up to $p = 100_{.10}$ bar and close connection to HP-pump by means of shut-off valve.

During a 5 min. testing time a pressure drop of max. 2% (2 bar) is allowed.

▲ If the maximum pressure of 100 bar is exceeded, there will be an excessive piston adjustment and a repeated disassembly of the brake or the adjusting is required to reset the gripping rings to the adjusting dimension.

Low-pressure test :

Reduce test pressure to $p = 5$ bar and close the shut-off valve again.

During a 5 min. testing time a pressure drop is not allowed.

※ Special tool

HP-Pump 5870 287 007

Mini-measuring hub 5870 950 115

(9/16"- 18UNF)

※ Prior to putting the axle into operation, fill in the oil acc. to the lubrication instructions.

3) DISASSEMBLY OF DIFFERENTIAL CARRIER AND BRAKE TUBES

(1) Disassembly of differential carrier

① Fasten axle on assembly truck.

※ Special tool

Assembly truck 5870 350 000

Holding fixtures 5870 350 077

Clamps 5870 350 075

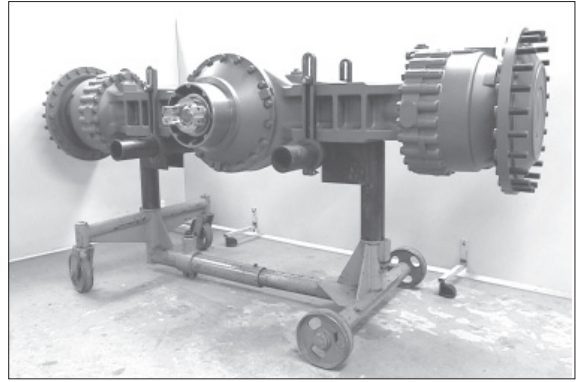

7577AAXF001

② Loosen screw plugs (3EA, see Figure 7577AAXF002 and 003) and drain oil from axle casing.

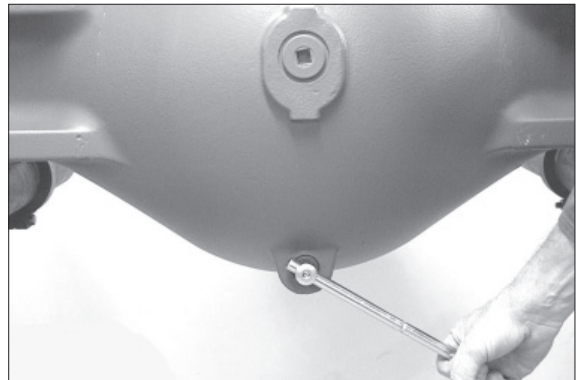

7577AAXF002

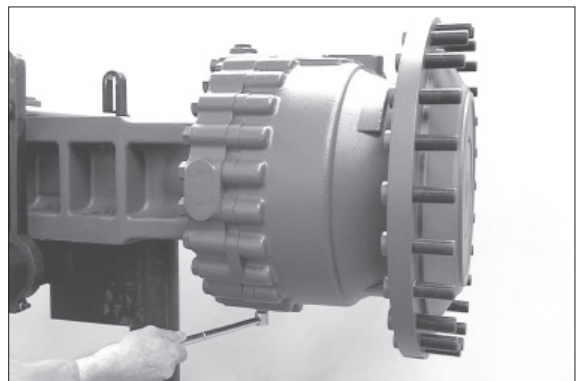

7577AAXF003

③ Secure output by means of lifting tackle and loosen hexagon screws.

※ Special tool

Lifting bracket 5870 281 043

※ Make step (fig. 7577AAXF007~9) on both output sides.

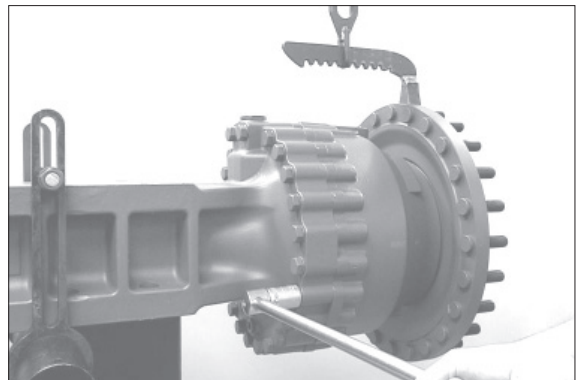

7577AAXF007

④ Separate complete output from the axle casing.

※ Pay attention to released O-ring (see arrow).

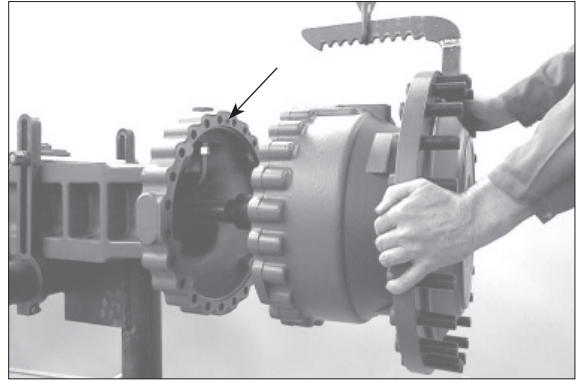

7577AAXF008

⑤ Pull stub shaft out of the sun gear shaft.

※ Pay attention to released shim (s).

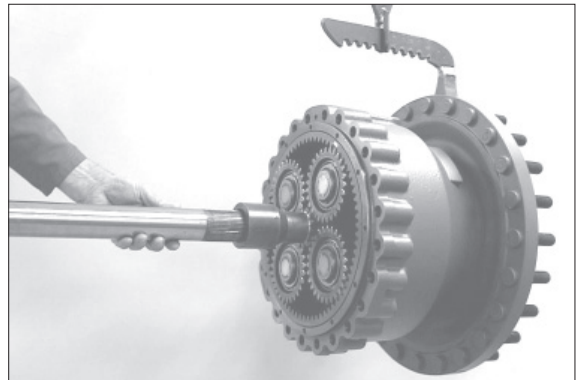

7577AAXF009

⑥ Loosen hexagon screws.

※ Mark location of differential carrier to the axle casing (see arrows).

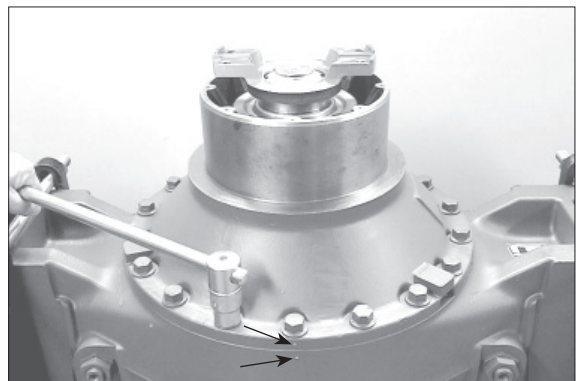

7577AAXF081

⑦ Lift differential carrier by means of lifting tackle out of the axle casing.

※ Special tool

Lifting tackle

5870 281 044

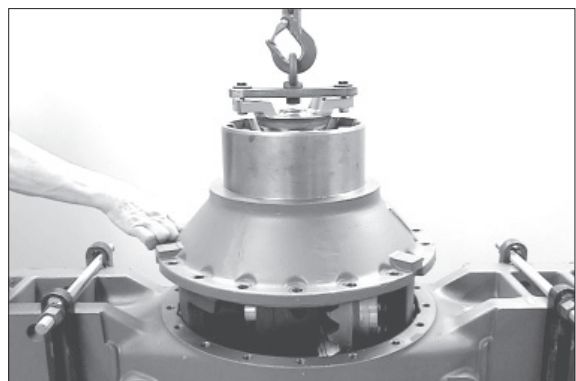

7577AAXF082

⑧ Fasten differential carrier to assembly truck.

※ Special tool

Assembly truck 5870 350 000

Holding fixture 5870 350 004

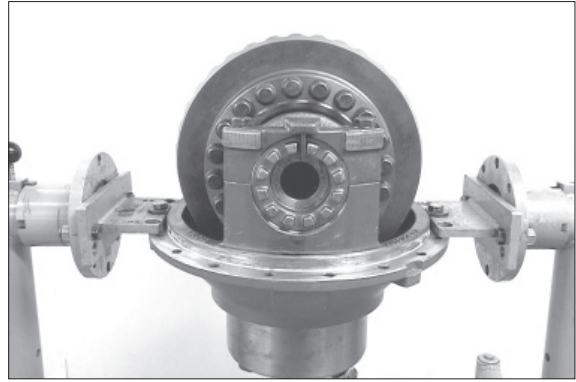

7577AAXF083

⑨ Drive out slotted pins.

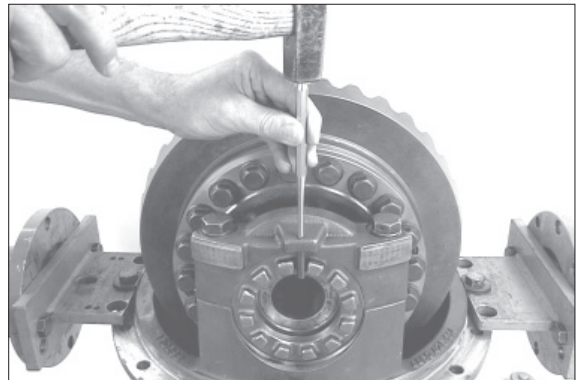

7577AAXF084

⑩ Loosen and remove both adjusting nuts.

※ Special tool

Socket spanner 5870 656 080

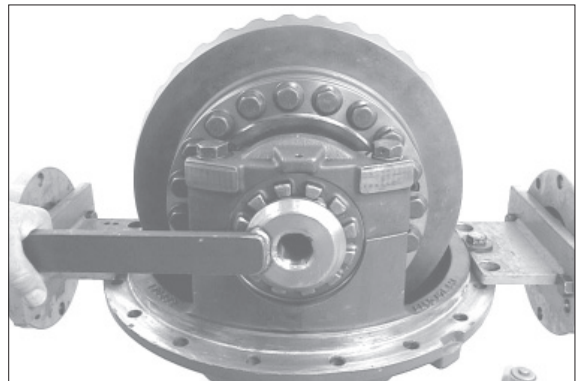

7577AAXF085

⑪ Heat axle drive housing by means of hot-air blower.

※ Special tool

Hot-air blower 230 V 5870 221 500

Hot-air blower 115 V 5870 221 501

※ Hexagon screws are installed with Loctite (type No. 262).

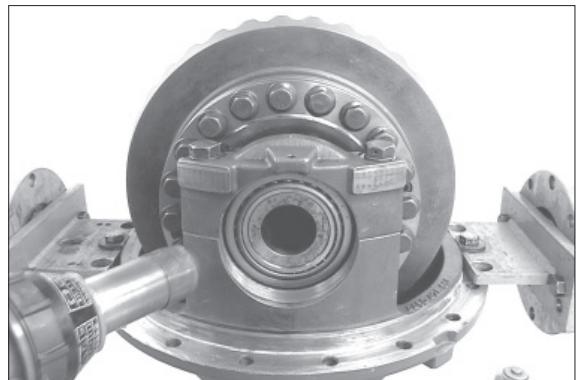

7577AAXF086

⑫ Loosen hexagon screws and take off bearing bracket.

▲ Loosen hexagon screws by hand only.

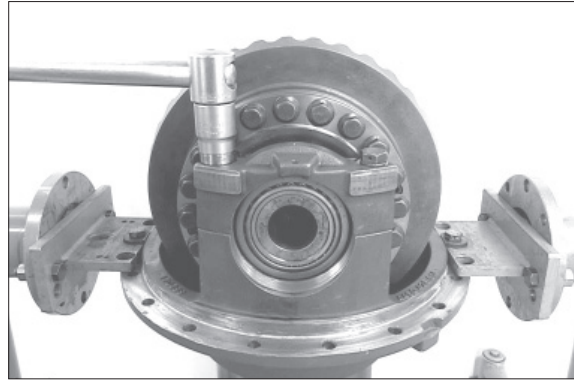

7577AAXF087

⑬ Remove both bearing outer rings.

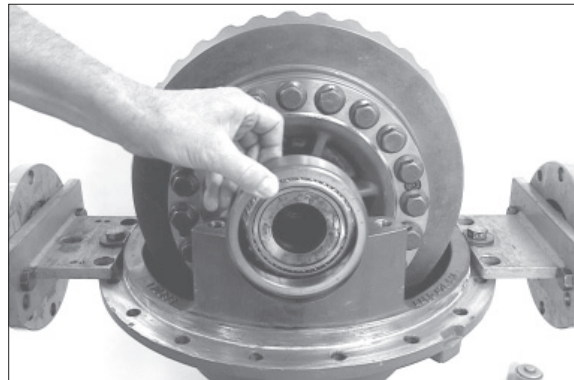

7577AAXF088

⑭ Lift differential out of the housing by means of lifting tackle.

※ Special tool
Lifting tackle 5870 281 013

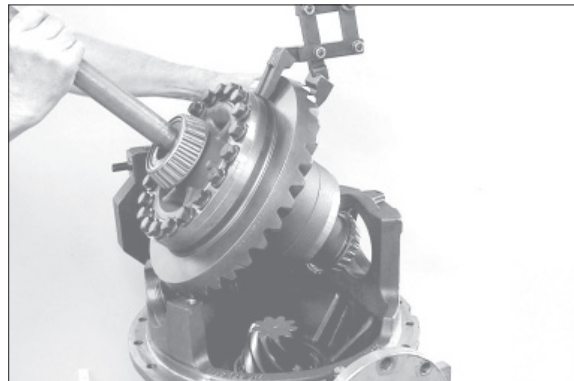

7577AAXF089

Disassembly of limited slip differential

⑮ Pull bearing inner ring from the differential housing.

※ Special tool
Gripping insert 5873 002 025
Basic set 5873 002 001



7577AAXF090

⑩ Pull bearing inner ring from the housing cover.

※ Special tool

Rapid grip

5873 012 012

Basic set

5873 002 001

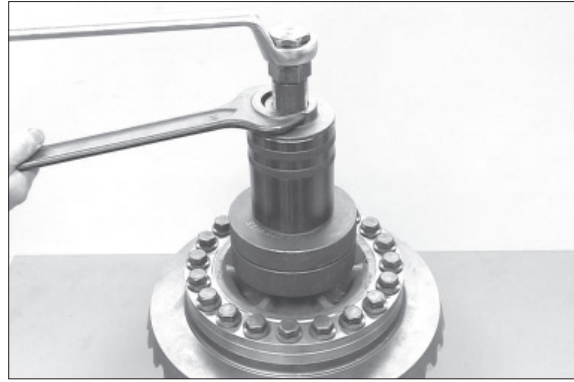

7577AAXF091

⑪ Fasten differential by means of press, loosen locking screws and remove released housing cover.

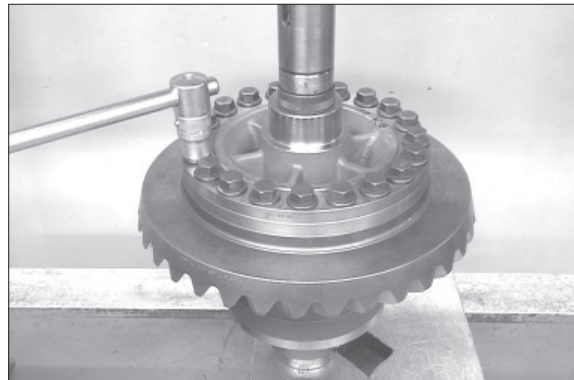

7577AAXF092

⑫ Remove all single parts from the differential housing.

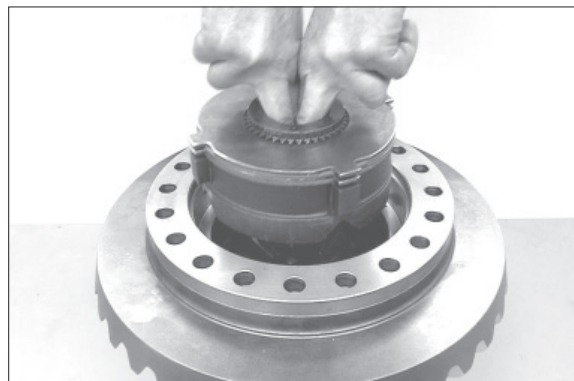

7577AAXF093

⑬ Press off crown wheel from the differential housing.

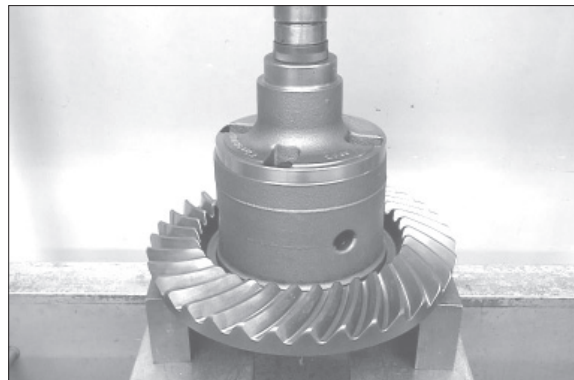

7577AAXF094

Disassembly of drive pinion

⑳ Heat hexagon nut by means of hot-air blower.

※ Special tool

Hot-air blower 230 V 5870 221 500

Hot-air blower 115 V 5870 221 501

※ Slotted nut is locked with loctite (type No. 262).

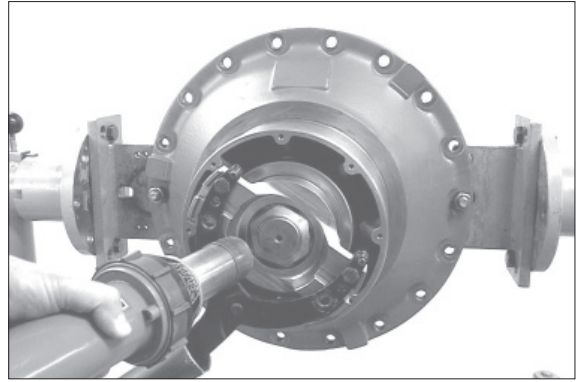

7577AAXF095

㉑ Loosen hexagon nut and remove the washer behind it.

※ Special tool

Fixture 5870 240 002

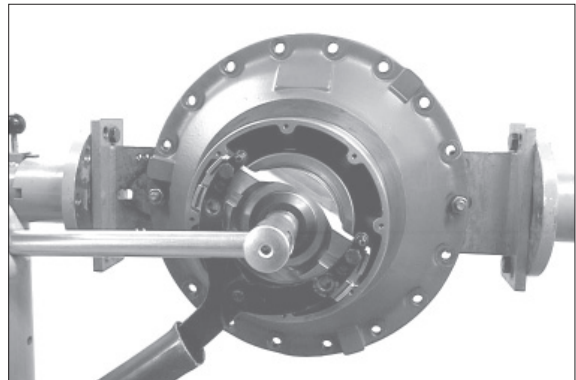

7577AAXF096

㉒ Pull input flange from the drive pinion.

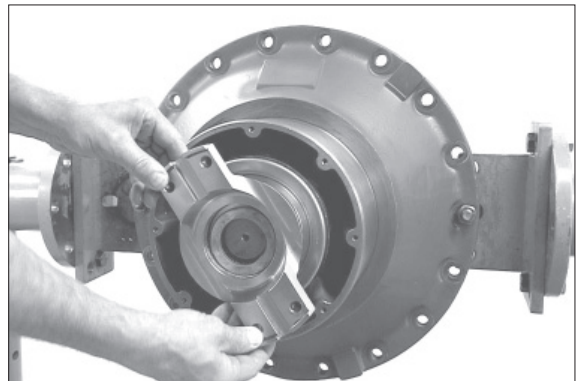

7577AAXF097

㉓ Press shaft seal out of the axle drive housing.

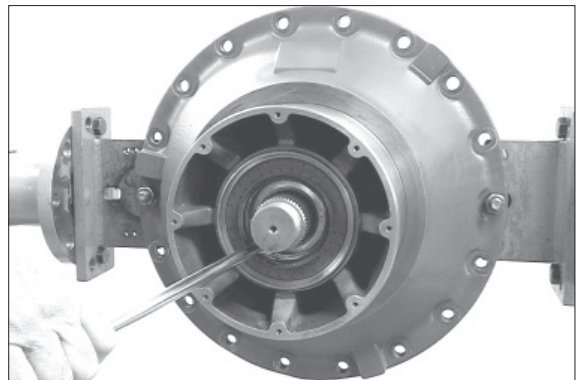

7577AAXF098

- ②④ Press drive pinion out of the axle drive housing by means of two-armed puller and remove the released bearing inner ring.

※ Special tool
Two-armed puller 5870 970 007

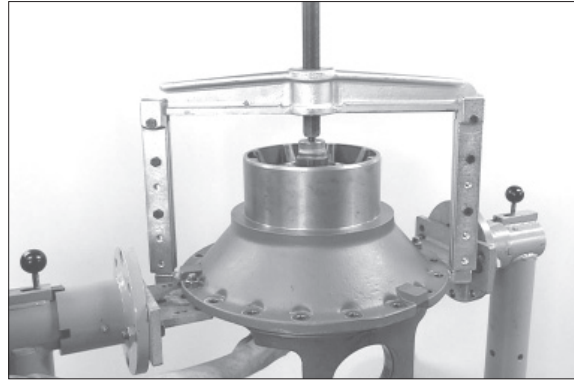

7577AAXF099

- ②⑤ Take off spacer ring and pull bearing inner ring from the drive pinion.

※ Special tool
Gripping insert 5873 002 032
Basic set 5873 002 001



7577AAXF100

- ②⑥ If necessary drive out both bearing outer rings from the axle drive housing.

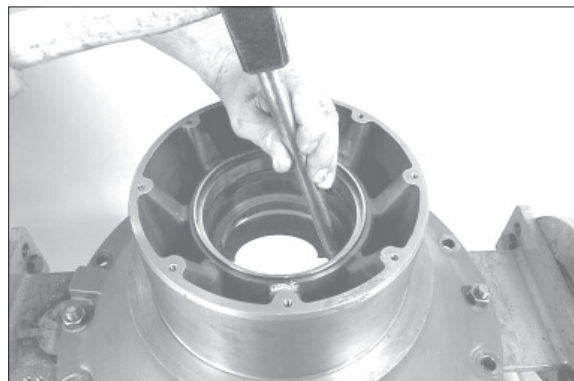

7577AAXF101

- ②⑦ Remove screw plug with vent valve from the axle casing.

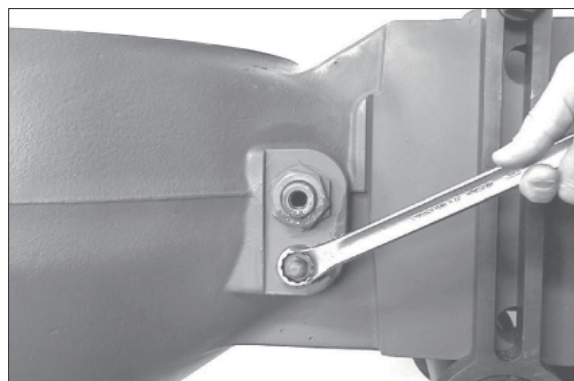

7577AAXF102

(2) Disassembly of brake tubes

- ① Loosen hexagon nut.
※ Step (figure 7577AAXF103~107) to be made on both sides.

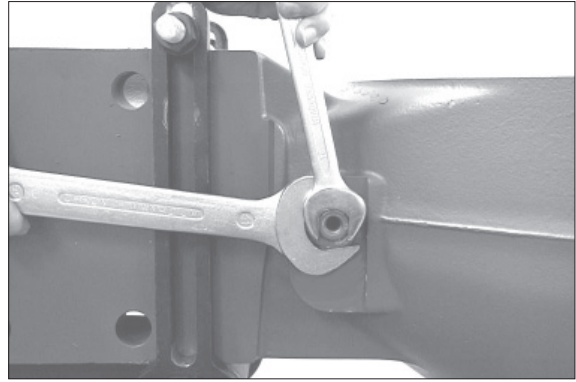

7577AAXF103

- ② Loosen union screw.

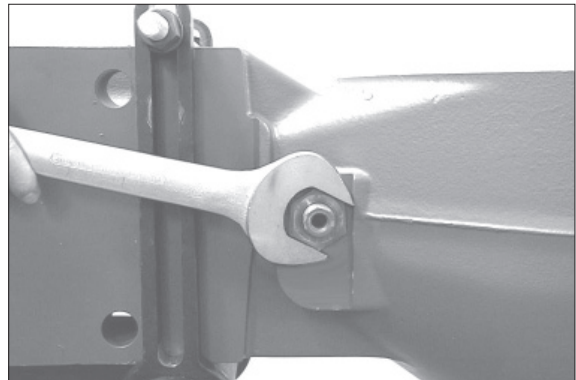

7577AAXF104

- ③ Loosen pipe union and remove released brake tube from the axle casing.

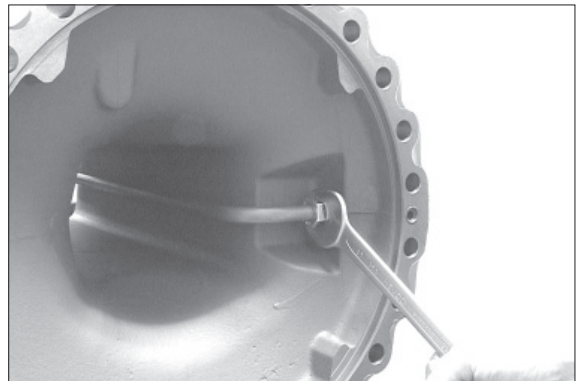

7577AAXF105

- ④ Remove vent valve from the connection part.

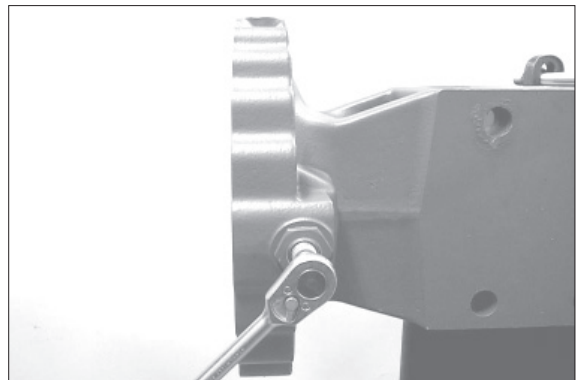

7577AAXF106

- ⑤ Loosen connection part and remove it from the axle casing.

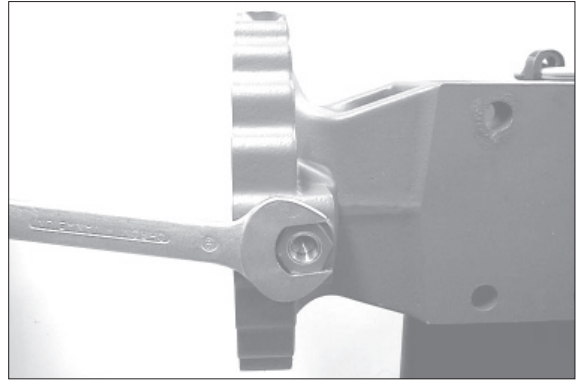

7577AAXF107

4) REASSEMBLY OF BRAKE TUBES AND DIFFERENTIAL CARRIER

(1) Reassembly of brake tubes

① Preassemble connection part as shown in opposite figure.

- 1 Vent valve
- 2 Connection part
- 3 O-Ring
- 4 Rectangular ring

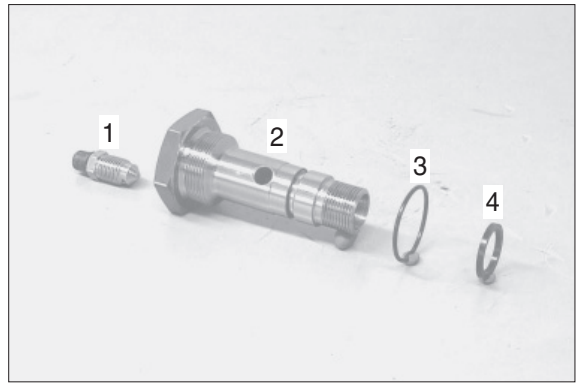

7577AAXF108

※ Step (figure 7577AAXF108~114) is to be made on both output sides.

② Install connection part.

- Tightening torque : 13.3 kgf · m
(95.9 lbf · ft)

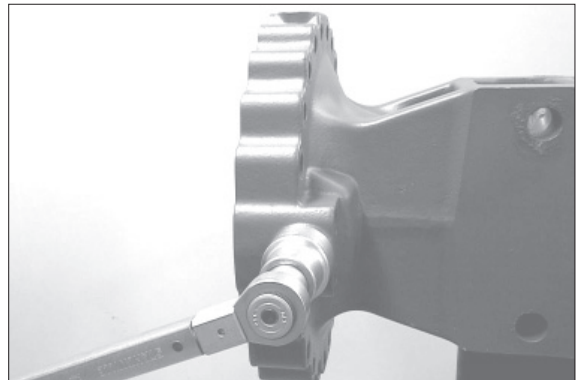

7577AAXF109

③ Provide union screw with new O-ring and install it.

- Tightening torque : 15.3 kgf · m
(111 lbf · ft)

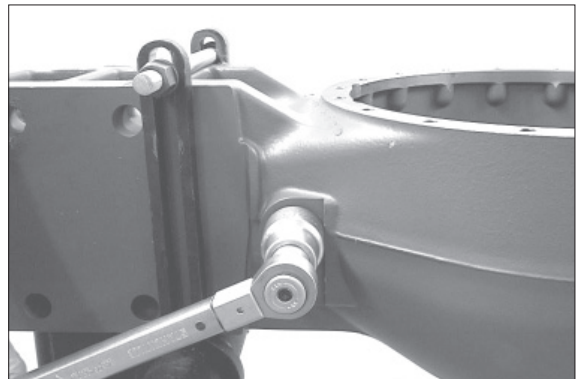

7577AAXF110

④ Insert O-ring (see arrow) into the annular groove of the brake tube.



7577AAXF111

- ⑤ Insert brake tube into the axle casing, assembling the connection part (see arrow 1) through the union screw (see arrow 2).

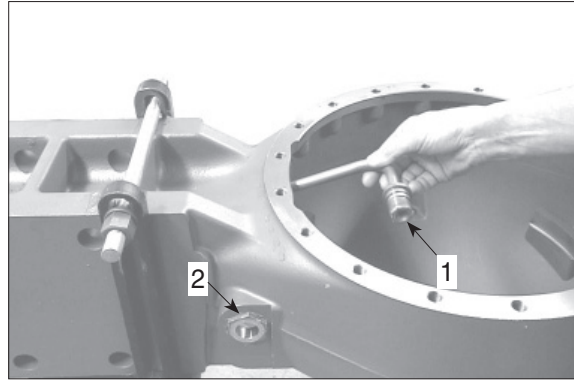

7577AAXF112

- ⑥ Fasten brake tube by means of hexagon nut and union nut (see below figure).

- Tightening torque : 10.2 kgf · m
(73.8 lbf · ft)

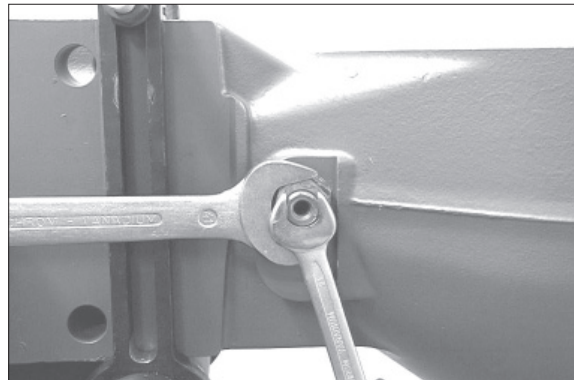

7577AAXF113

- Tightening torque : 8.2 kgf · m
(59 lbf · ft)

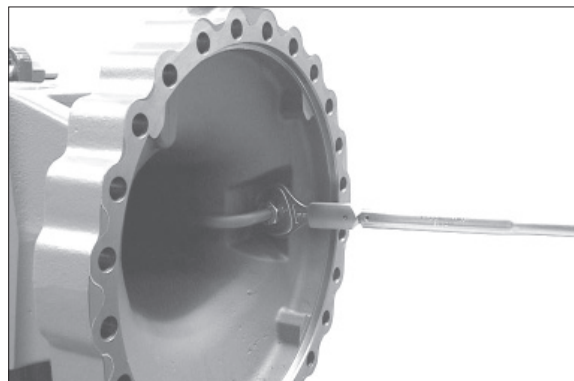

7577AAXF114

- ⑦ Preassemble screw plug as shown in opposite figure.

- 1 O-Ring
- 2 Screw plug
- 3 Vent valve

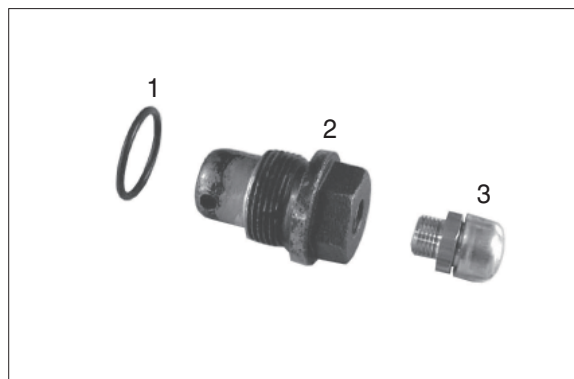

7577AAXF115

⑧ Install screw plug.

- Tightening torque : 7.1 kgf · m
(51.6 lbf · ft)

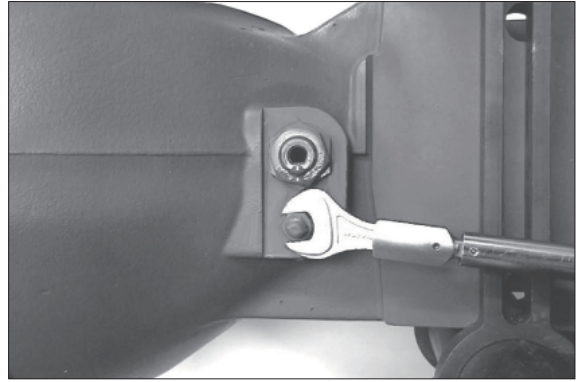

7577AAXF116

(2) Reassembly of differential carrier

※ If crown wheel or drive pinion are damaged, both parts have to be replaced together.

For new installation of a complete bevel gear set pay attention to the same pair number of drive pinion and crown wheel.

Determine shim thickness for a perfect tooth contact pattern

※ Make the following measuring steps at maximum accuracy.

Inexact measurements result in a faulty tooth contact pattern and require a repeated disassembly and reassembly of the drive pinion as well as of the differential.

① Install adapter pieces (1) and preliminarily fasten the bearing bracket by means of hexagon screws.

Then install stop washer (4) and measuring pin (3) and assemble measuring shaft (2) (see sketch).

※ Special tool

Adapter pieces	5870 500 044
Measuring shaft	5870 500 001
Measuring pin	5870 351 016
Stop washer	5870 351 027

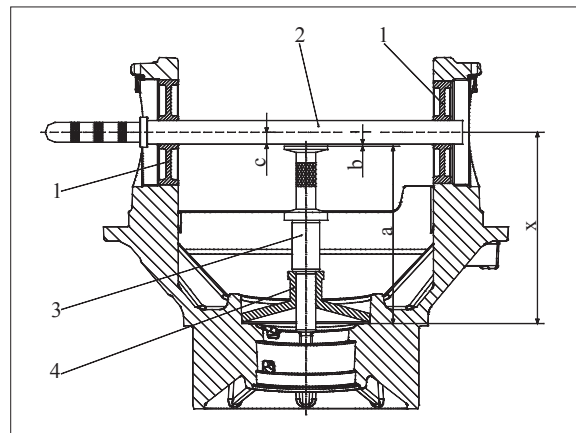

7577AAXF117

② Determine gap (dimension b) between measuring shaft and measuring pin by means of feeler gauge.

Dimension b e.g. 0.25 mm

EXAMPLE A :

Dimension a (= Measuring pin + stop washer) 190.00 mm
 Dimension b + 0.25 mm
 Dimension c + 15.00 mm
results in dimension X = 205.25 mm

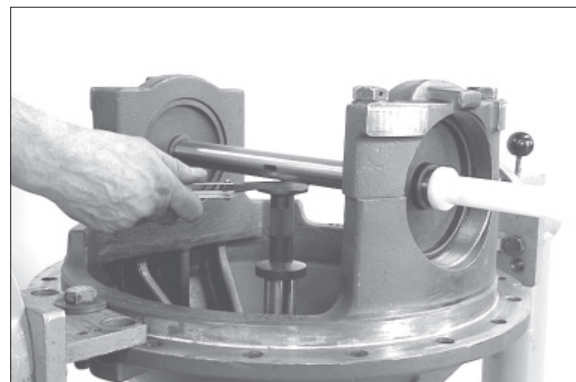

7577AAXF118

③ Determine dimension I (bearing width).

Dimension I e.g. 36.00 mm

※ Special tool

Digital depth gauge 5870 200 072

Gauge blocks 5870 200 066

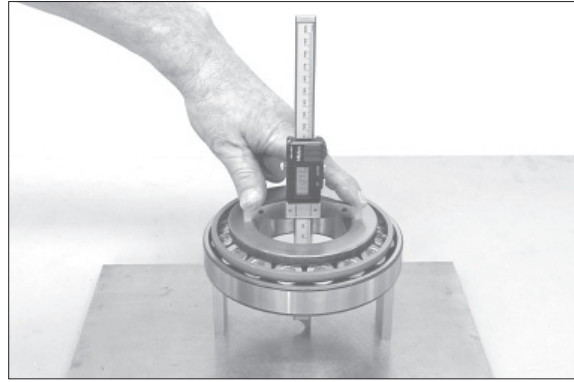

7577AAXF119

④ Read dimension II (dimension for pinion).

Dimension II e.g. 168.05 mm

EXAMPLE B :

Dimension I 36.00 mm

Dimension II + 181.05 mm

results in dimension Y = 204.05 mm

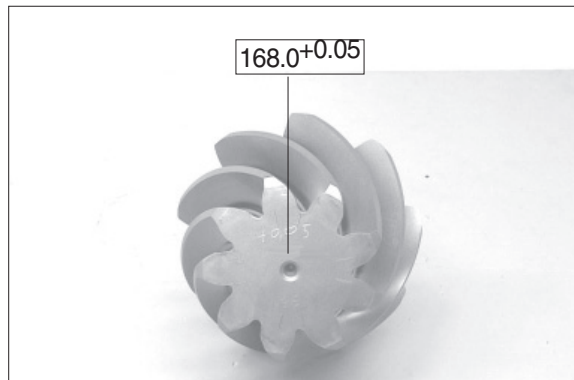

7577AAXF120

EXAMPLE C :

Dimension X 205.25 mm

Dimension Y - 204.05 mm

Difference = shim e.g. s = 1.20 mm

Install the drive pinion

⑤ Place determined shim e.g. $s = 1.20$ mm into the bearing bore.

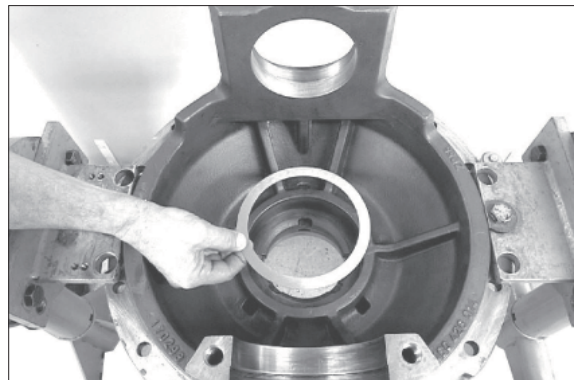

7577AAXF121

- ⑥ Undercool bearing outer ring and insert it into the bearing bore until contact.

※ Special tool

Driver 5870 058 060

Handle 5870 260 002

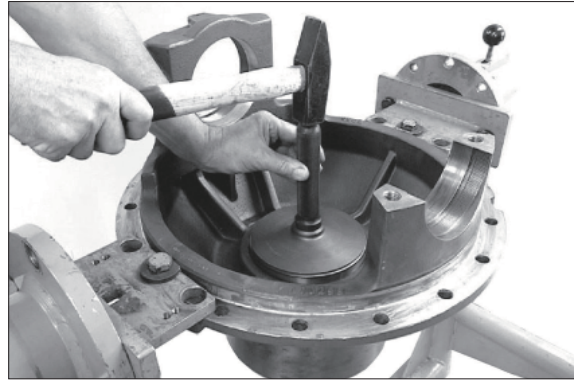

7577AAXF122

- ⑦ Undercool bearing outer ring on the input flange side and insert it until contact.

※ Special tool

Driver 5870 058 087

Handle 5870 260 002



7577AAXF123

- ⑧ Press bearing inner ring on the drive pinion until contact.

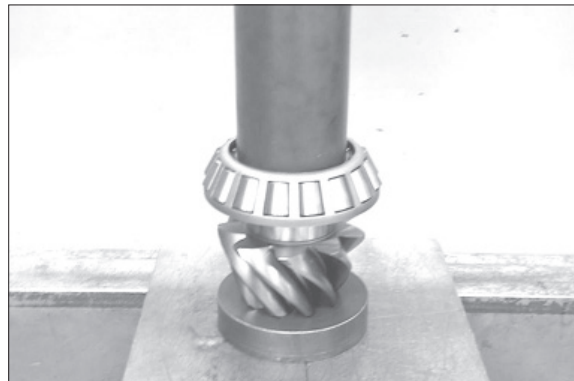

7577AAXF124

Adjust rolling moment of drive pinion bearing 0.15 ~ 0.31kgf · m (figure 7577AAXF125~133) :

- ⑨ Assemble spacer ring (e.g. s = 8.70 mm).

※ As per experience the required rolling moment is obtained by use of the spacer ring (e.g. s = 8.70 mm) available at disassembly.

However, a later checking of the rolling moment is imperative.

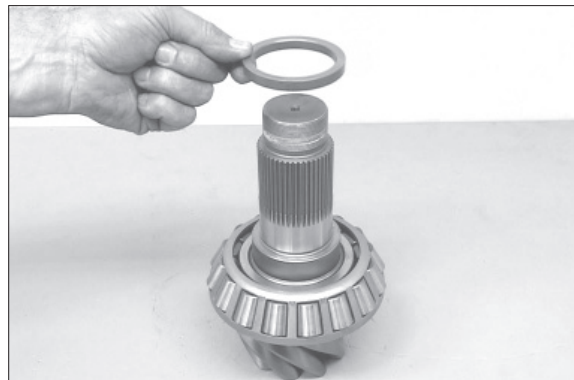

7577AAXF125

- ⑩ Insert preassembled drive pinion into the axle drive housing and assemble the heated bearing inner ring until contact.

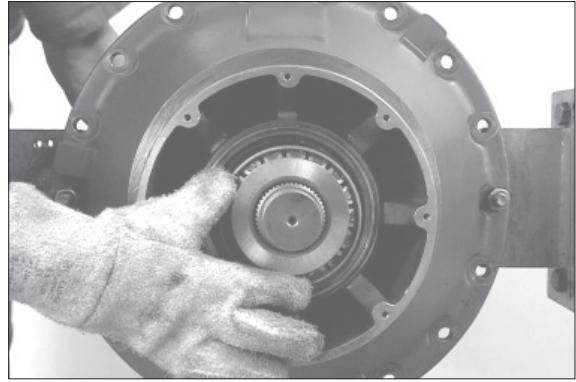

7577AAXF126

- ⑪ Press dust protection on the input flange until contact.

※ Special tool

Driver

5870 056 012

Handle

5870 260 002

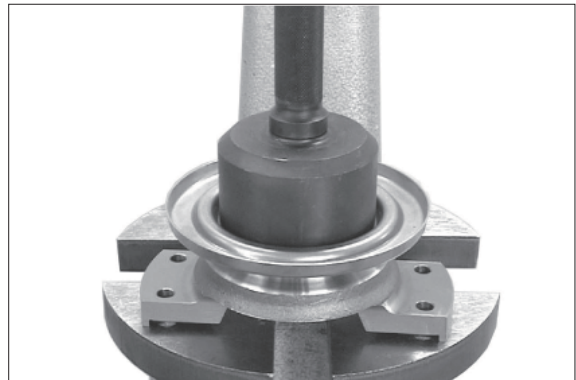

7577AAXF127

- ⑫ Assemble input flange.

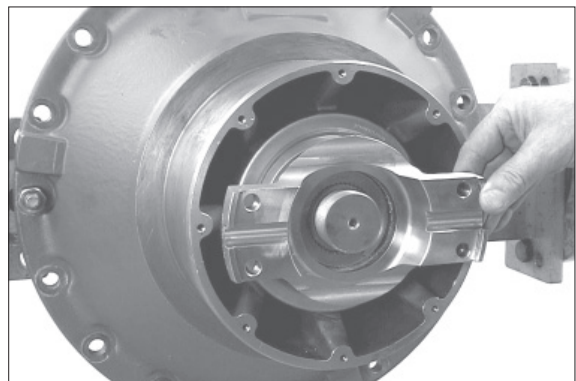

7577AAXF128

- ⑬ Assemble washer.

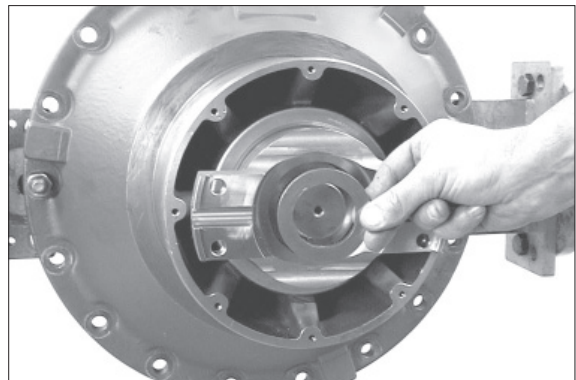

7577AAXF129

- ⑭ Unscrew hexagon nut by hand and tighten it.

· Tightening torque : 71.4 kgf · m
(516 lbf · ft)

※ Special tool

Fixture 5870 240 002

※ When tightening rotate drive pinion in both directions several times.

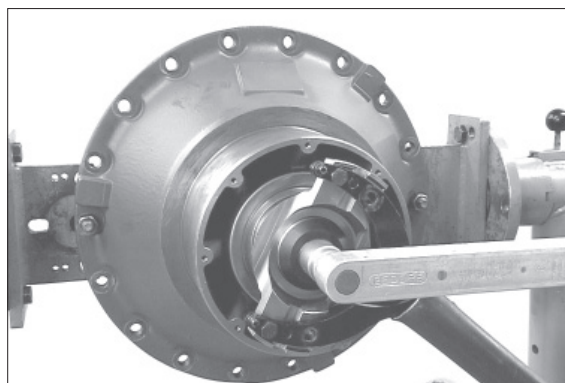

7577AAXF130

- ⑮ Check rolling moment (0.15~0.31 kgf · m).

※ For new bearings it should be tried to achieve the max. value of the rolling moment.

▲ If the required rolling moment is not obtained, correct it with an adequate spacer ring (figure 7577AAXF125), according to the following indications :
Rolling moment too low - install a thinner spacer ring
Rolling moment too high - install a thicker spacer ring.

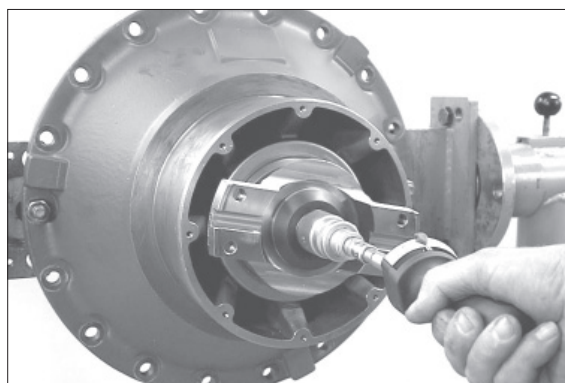

7577AAXF131

- ⑯ Then loosen the hexagon nut again and pull input flange from the drive pinion.

Install shaft seal with the sealing lip showing to the oil chamber (downwards).

※ Special tool

Driver 5870 048 225

※ The exact installation position of the shaft seal will be obtained by using the exact driver.



7577AAXF132

▲ Just before the installation wet the outer diameter of the shaft seal with spirit and fill the space between sealing and dust lip with grease.

- ⑰ Assemble input flange and finally fasten it by means of washer and hexagon nut.

· Tightening torque : 71.4 kgf · m (516 lbf · ft)

※ Special tool

Fixture 5870 240 002

▲ Apply Loctite (type No. 262) onto the thread of the hexagon nut.

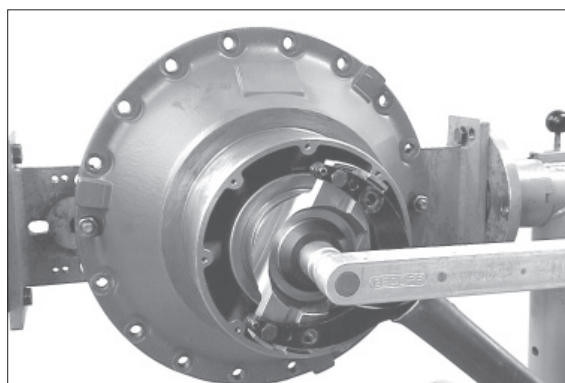

7577AAXF133

Reassembly of limited slip differential

- ⑱ Place both thrust washers into the differential housing.
- ※ Prior to installation all single parts of the differential must be oiled.

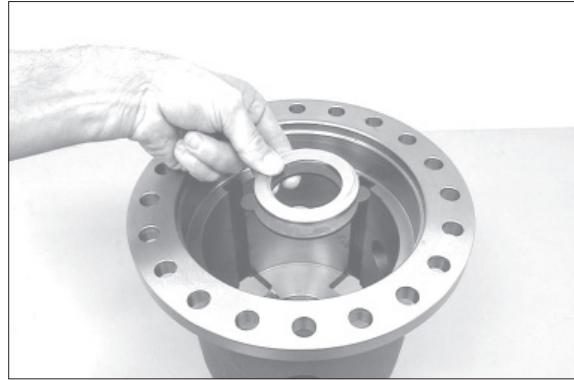

7577AAXF134

- ⑲ Starting with an outer clutch disc install alternately the outer and inner clutch discs.

▲ Thickness of the disc pack must be identical on both sides.

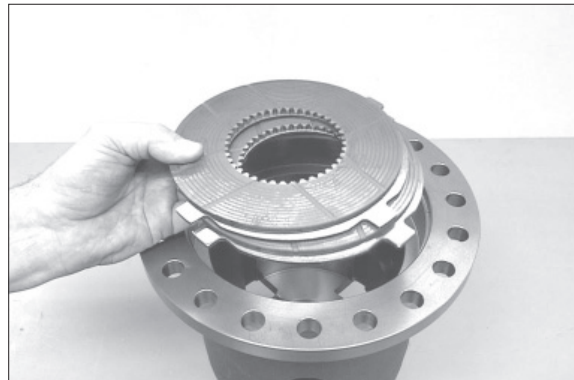

7577AAXF135

- ⑳ Put on the pressure ring.

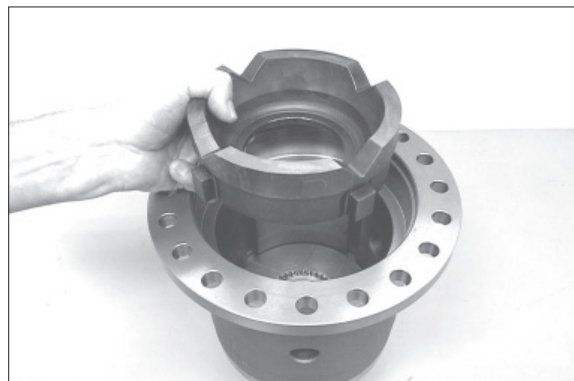

7577AAXF136

- ㉑ Insert axle bevel gear until contact and at the same time assemble all inner clutch discs with the spline.

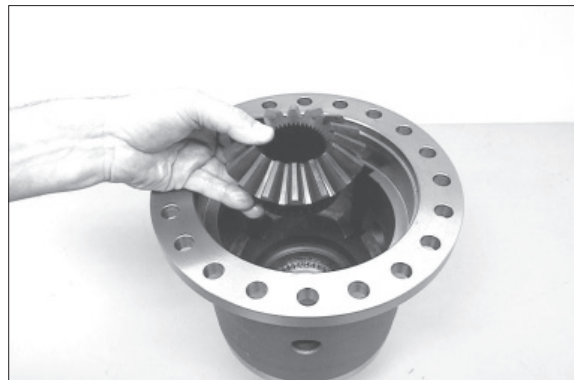

7577AAXF137

- ⑳ Preassemble differential spider and insert it into the differential housing.

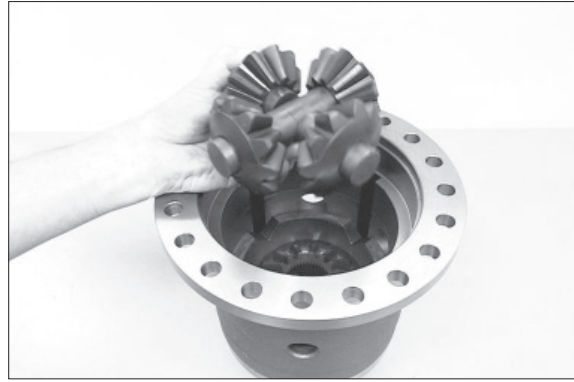

7577AAXF138

- ㉑ Put on the second axle bevel gear.

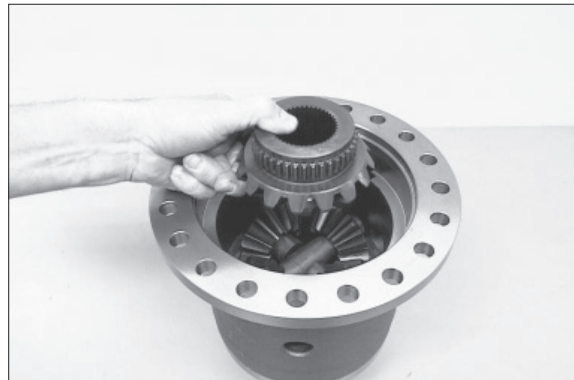

7577AAXF139

- ㉒ Insert the second pressure ring into the differential housing.



7577AAXF140

- ㉓ Starting with an inner clutch disc install alternately the inner and outer clutch discs.

- ⚠ Thickness of the clutch disc pack must be identical on both sides.

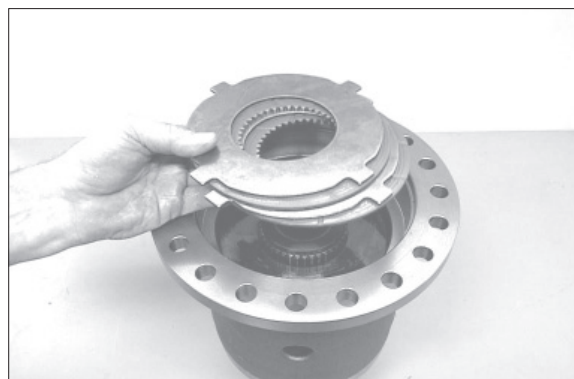

7577AAXF141

Determine disc clearance 0.2~0.8 mm

- ②⑥ Determine dimension I, from mounting face of the differential housing to plane face of the outer clutch disc.

Dimension I e.g 38.05 mm

※ Special tool

Digital depth gauge 5870 200 072

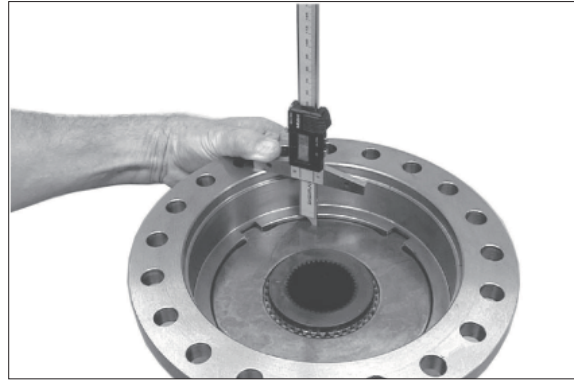

7577AAXF142

- ②⑦ Determine dimension II, from contact surface of the outer clutch disc to the mounting face of the housing cover.

Dimension II e.g 37.75 mm

EXAMPLE D :

Dimension I 38.05 mm

Dimension II - 37.75 mm

Difference = Disc clearance = 0.30 mm

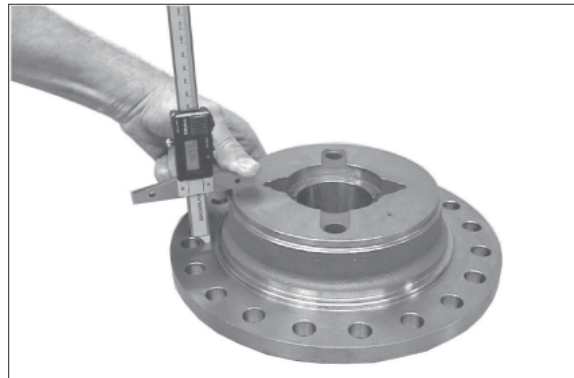

7577AAXF143

※ If the required disc clearance is not obtained, correct it with the adequate outer clutch discs (s = 2.9, s = 3.0, or s = 3.3 mm), taking care that the difference in thickness between the left and the right disc pack must only be 0.01 at a maximum.

- ②⑧ Fix both thrust washers with grease into the recess of the housing cover.

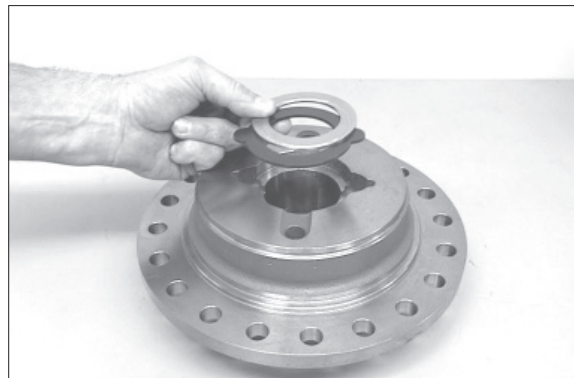

⑳ Put on the housing cover.

Then heat crown wheel and install it until contact.

※ Special tool

Adjusting screws 5870 204 040

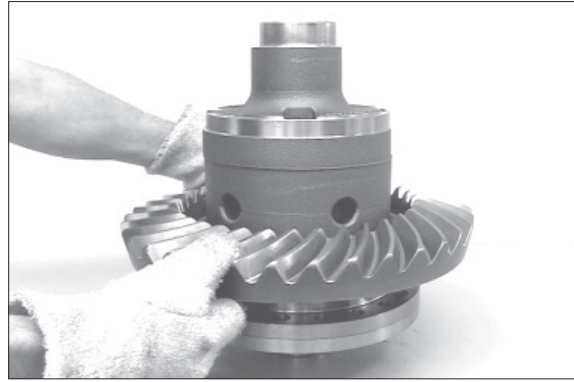

7577AAXF145

㉑ Fix differential by means of press and fasten crown wheel by means of new locking screws.

· Tightening torque : 41.8 kgf · m
(302 lbf · ft)

▲ Only use of new locking screws is permissible.

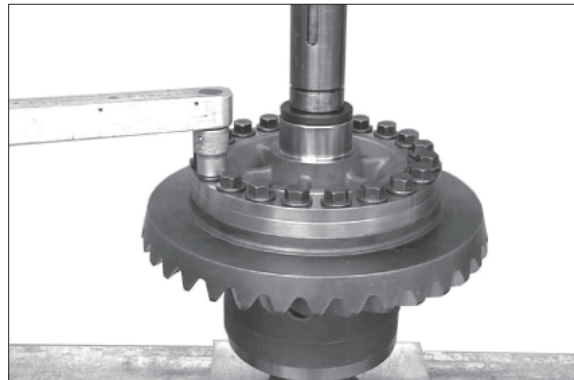

7577AAXF146

㉒ Press on both bearing outer rings until contact.



7577AAXF147

㉓ Insert differential into the axle drive housing by means of lifting tackle.

※ Special tool

Lifting tackle 5870 281 013

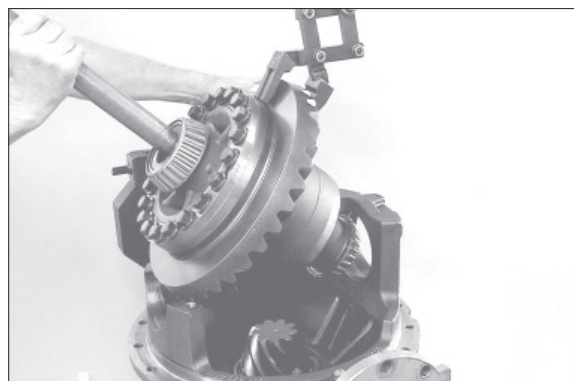

7577AAXF148

- ③ Place bearing outer ring into the axle drive housing.

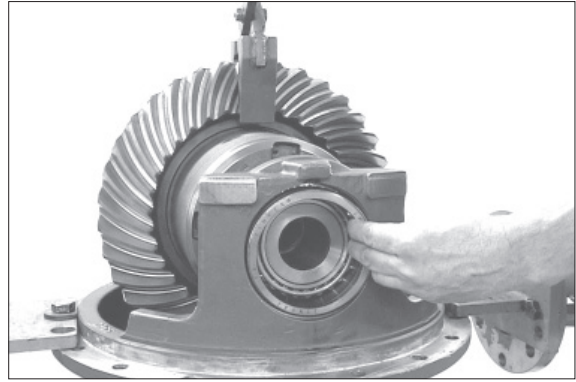

7577AAXF149

- ④ Preliminarily fix the bearing outer ring by means of adjusting nut.

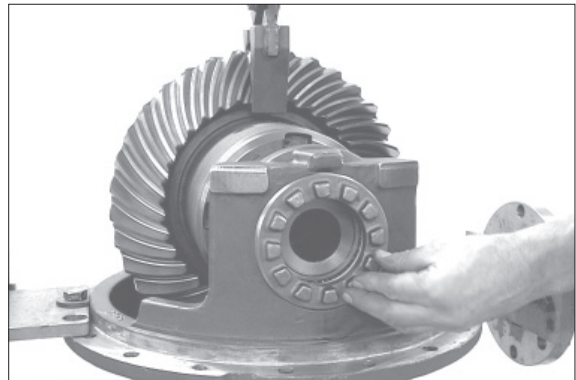

7577AAXF150

- ⑤ Install crown wheel-sided bearing outer ring.

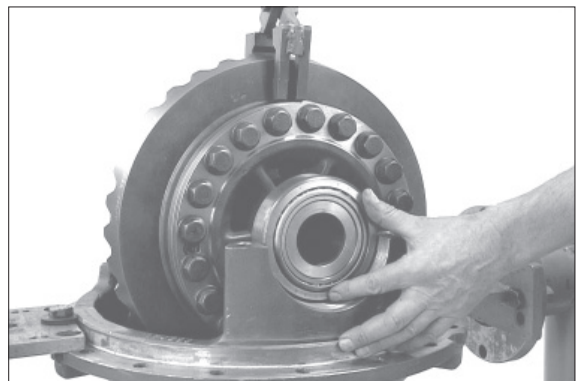

7577AAXF151

- ⑥ Preliminarily fix the crown wheel-sided bearing outer ring by means of the second adjusting nut.

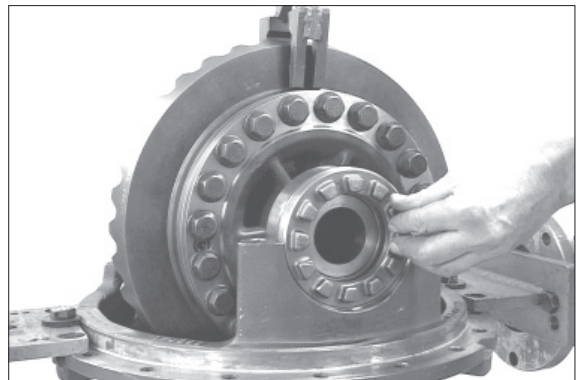

7577AAXF152

- ③7 Put on bearing bracket and fasten it by means of hexagon screws and washers.

- Tightening torque (M16/10.9) :
28.6 kgf · m (207 lbf · ft)

- ※ Pay attention to clearance of the adjusting nut.

▲ Apply Loctite (type No. 262) onto threads of the hexagon screws.

Adjustment of backlash and bearing preload

- ③8 Place dial indicator right-angled at the outer diameter of the tooth flank (crown wheel).

Then install both adjusting nuts only to such an extent that the required backlash - see the value etched on the outer diameter of the crown wheel - is reached.

- ※ Special tool
Magnetic stand 5870 200 055
Dial indicator 5870 200 057

- ※ At this step rotate the differential several times.

- ③9 Determine bracket width and correct it on both adjusting nuts, if required.

Bracket width 367.90 + 0.05 mm

- ※ Special tool
Caliper gauge 5870 200 058

Then check backlash once again.

- ※ Adjusting of the bracket width results in the required bearing preload.

- ④0 Cover some tooth flanks of the crown wheel with marking ink and roll crown wheel in both directions over the drive pinion.

Compare the obtained tooth contact pattern with the examples.

▲ If the tooth contact pattern differs, there has been a measuring error at determination of the shim (figure 7577AAXF121/page 3-217), what is imperative to be corrected.

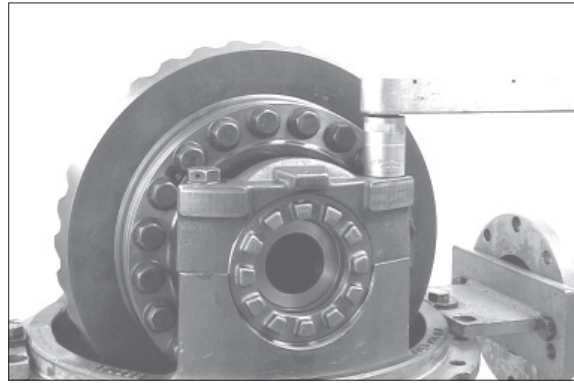

7577AAXF153

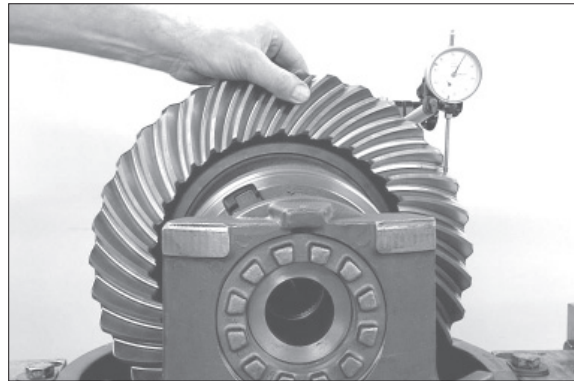

7577AAXF154

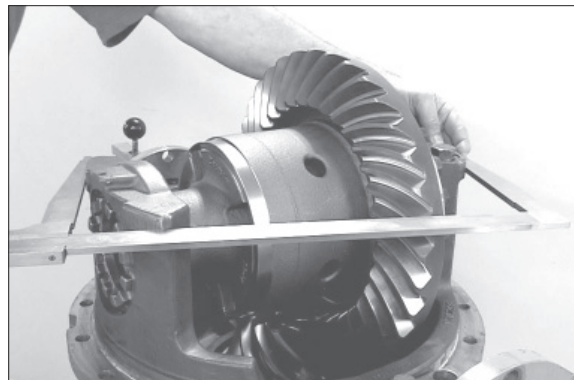

7577AAXF155

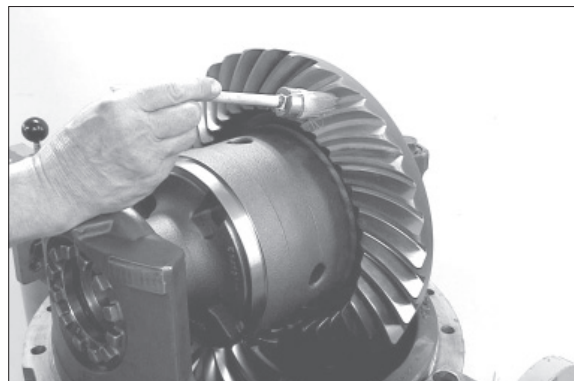

7577AAXF156

- ④① Secure both adjusting nuts by means of slotted pins.

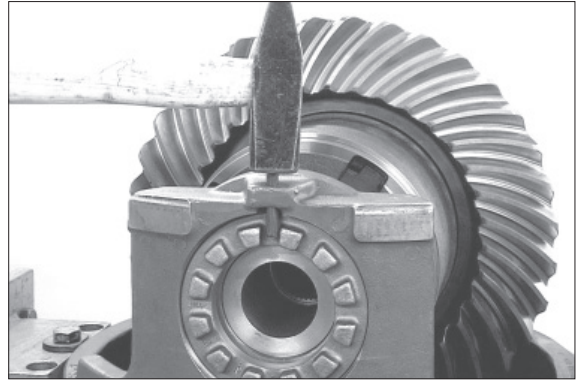

7577AAXF157

- ④② Install two adjusting screws and insert differential carrier into the axle casing until contact by means of lifting tackle.

※ Special tool
Adjusting screws 5870 204 022
Lifting tackle 5870 281 044

※ Observe radial location (see marking Page 3-254 / Figure 7577AAXF081).

- ▲ Apply sealing compound (three Bond Type 1215) on mounting face.

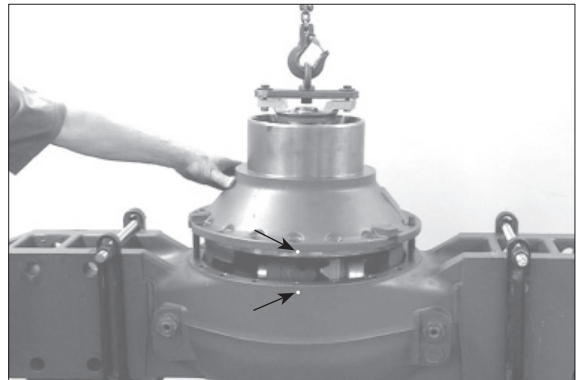

7577AAXF158

- ④③ Fasten differential carrier by means of new locking screws.

· Tightening torque : 25.5 kgf · m
(184 lbf · ft)

- ▲ Only use of the new locking screws is permissible.

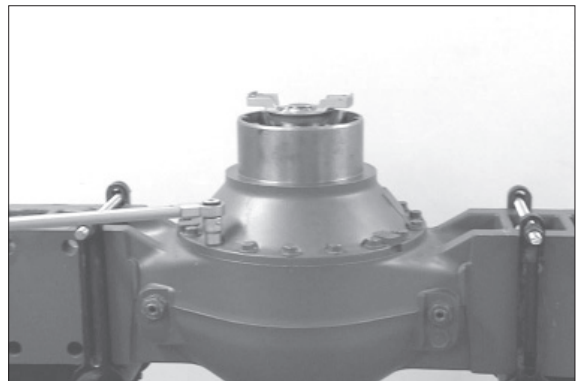

7577AAXF159

- ④④ Insert stub shaft into spline of the axle bevel gear until contact.

Then fix O-ring (see arrow) by means of grease into the recess of the axle casing.

※ Step (figure 7577AAXF160 ~ 163) is to be made on both output sides.

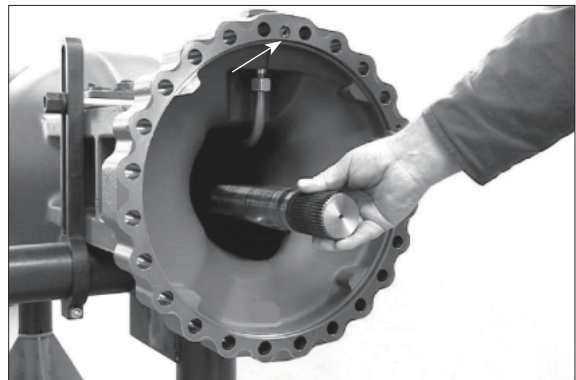

7577AAXF160

- ④⑤ Thrust washer (s) removed at disassembly have to be fixed in the sun gear shaft by means of grease.

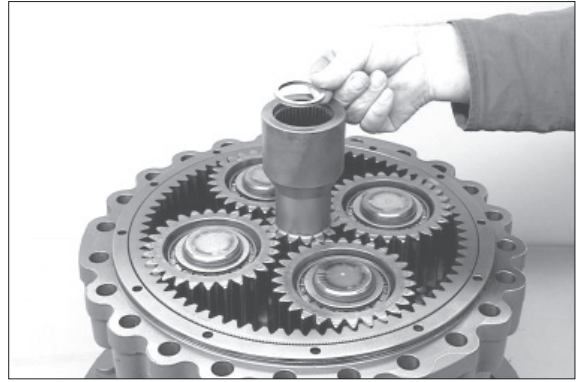

7577AAXF161

- ④⑥ Place complete output by means of lifting tackle to the axle casing until contact.

- ※ Special tool
Lifting bracket 5870 281 043

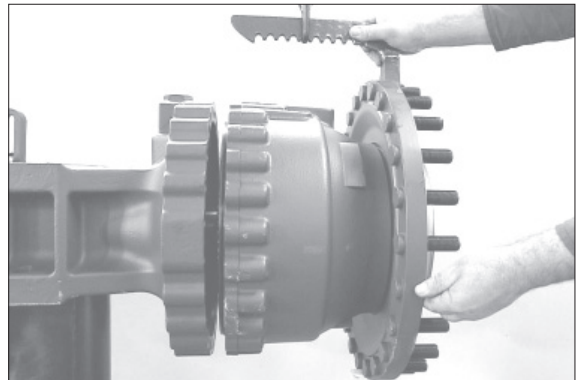

7577AAXF162

- ④⑦ Fasten output by means of hexagon screws and washers.

- Tightening torque (M18/10.9) :
39.8 kgf · m (288 lbf · ft)

- ※ Prior to putting into operation of the axle, fill oil in accordance with lubrication instructions.

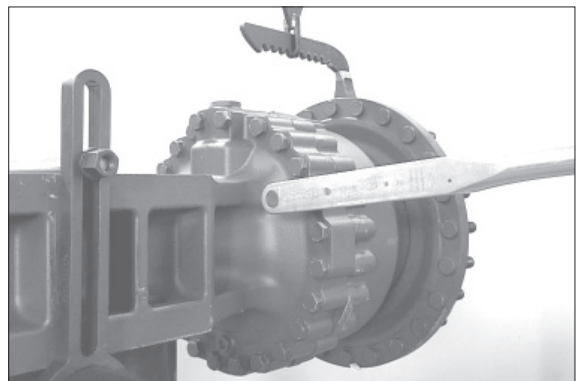

7577AAXF163