

## SECTION 5 STEERING SYSTEM

Group 1 Structure and Function .....	5-1
Group 2 Operational Checks and Troubleshooting .....	5-15
Group 3 Tests and Adjustments .....	5-23
Group 4 Disassembly and Assembly .....	5-30

# SECTION 5 STEERING SYSTEM

## GROUP 1 STRUCTURE AND FUNCTION

### 1. OUTLINE

The steering system of this machine consists of a fixed-displacement pump supplying a load sensing steering system and an open center loader system.

The components of the steering system are :

- Steering pump
- Steering valve(EHPS)
- Steering unit
- Cushion valve
- Steering cylinders

The steering pump, the first pump of main pump, draws hydraulic oil from the hydraulic tank.

Outlet flow from the pump flows to the priority valve of steering valve. The of steering valve preferentially supplies flow, on demand, to the steering unit. When the machine is steered, the steering unit routes flow to the steering cylinders to articulate the machine.

When the machine is not being steered, or if pump flow is greater than steering flow, the priority valve supplies flow to the loader system.

That is, output flow from the steering pump enters into the second pump of main pump for the operation of the attachment.

## 2. HYDRAULIC CIRCUIT

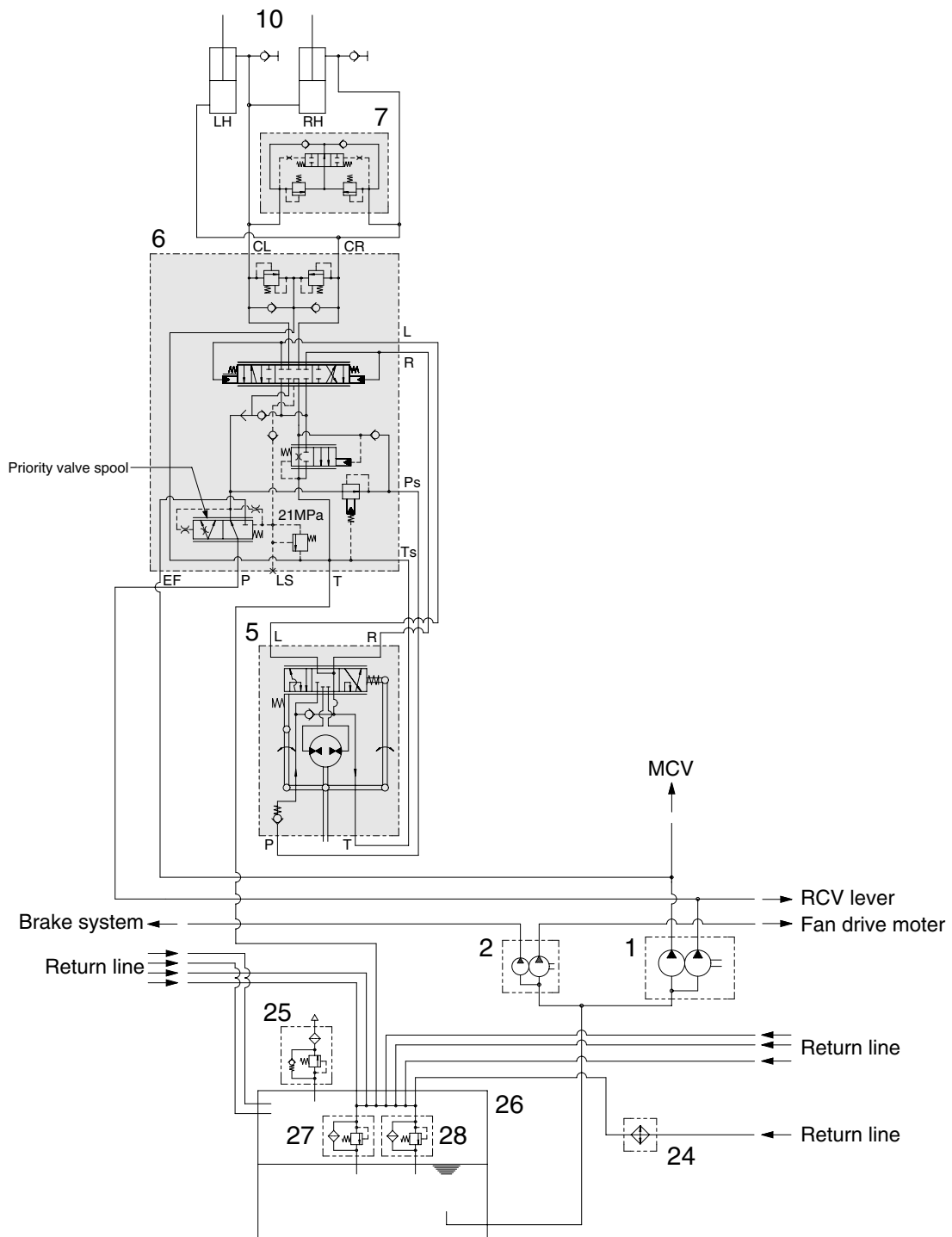

7607SE01

- |    |                      |    |                |
|----|----------------------|----|----------------|
| 1  | Main pump(Steering)  | 24 | Oil cooler     |
| 2  | Fan & brake pump     | 25 | Air breather   |
| 5  | Steering unit        | 26 | Hydraulic tank |
| 6  | Steering valve(EHPS) | 27 | Return filter  |
| 7  | Cushion valve        | 28 | Bypass valve   |
| 10 | Steering cylinder    |    |                |





### 3) RIGHT TURN

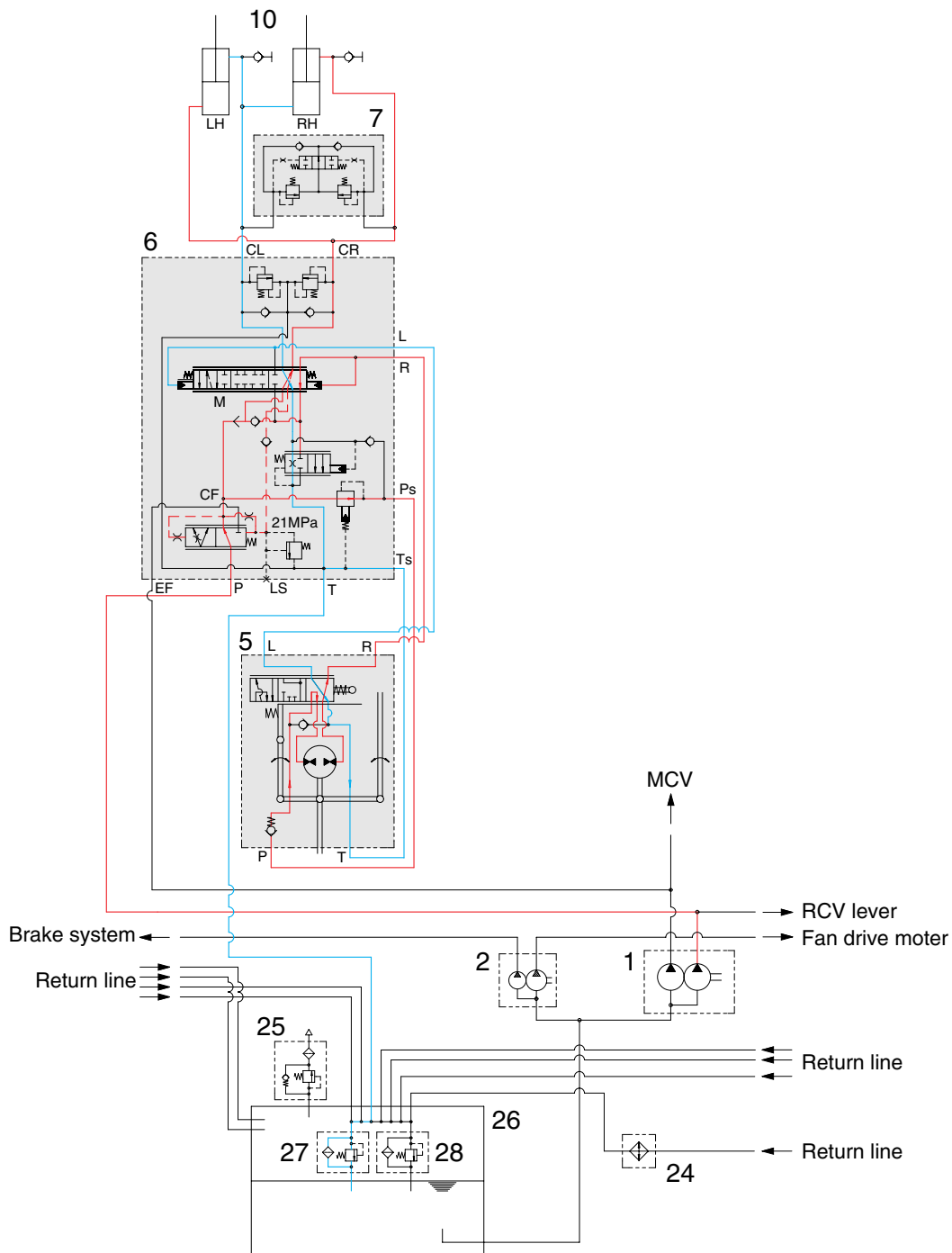

7607SE04

- When the steering wheel is turned to the right, the pressure oil from the steering unit fill on the right side chamber of main steering spool(M), and main steering spool moves to the left in the direction.
- At the same time of moving of main steering spool, LS signal will be blocked.
- If LS signal of main steering spool is blocked, it cause to increase pressure of left chamber of priority valve and then priority valve to be pushed to left side. Consequently, oil will flow via CF of priority valve to main spool. That oil will push steering cylinder rod out and it will cause wheel loader to be steered to right side.
- The rate of movement of main steering spool is concluded as flow rate, which is kept in right chamber from steering unit. Furthermore the rate controls speed of movement for cylinder.

### 3. STEERING VALVE(EHPS)

#### 1) STRUCTURE

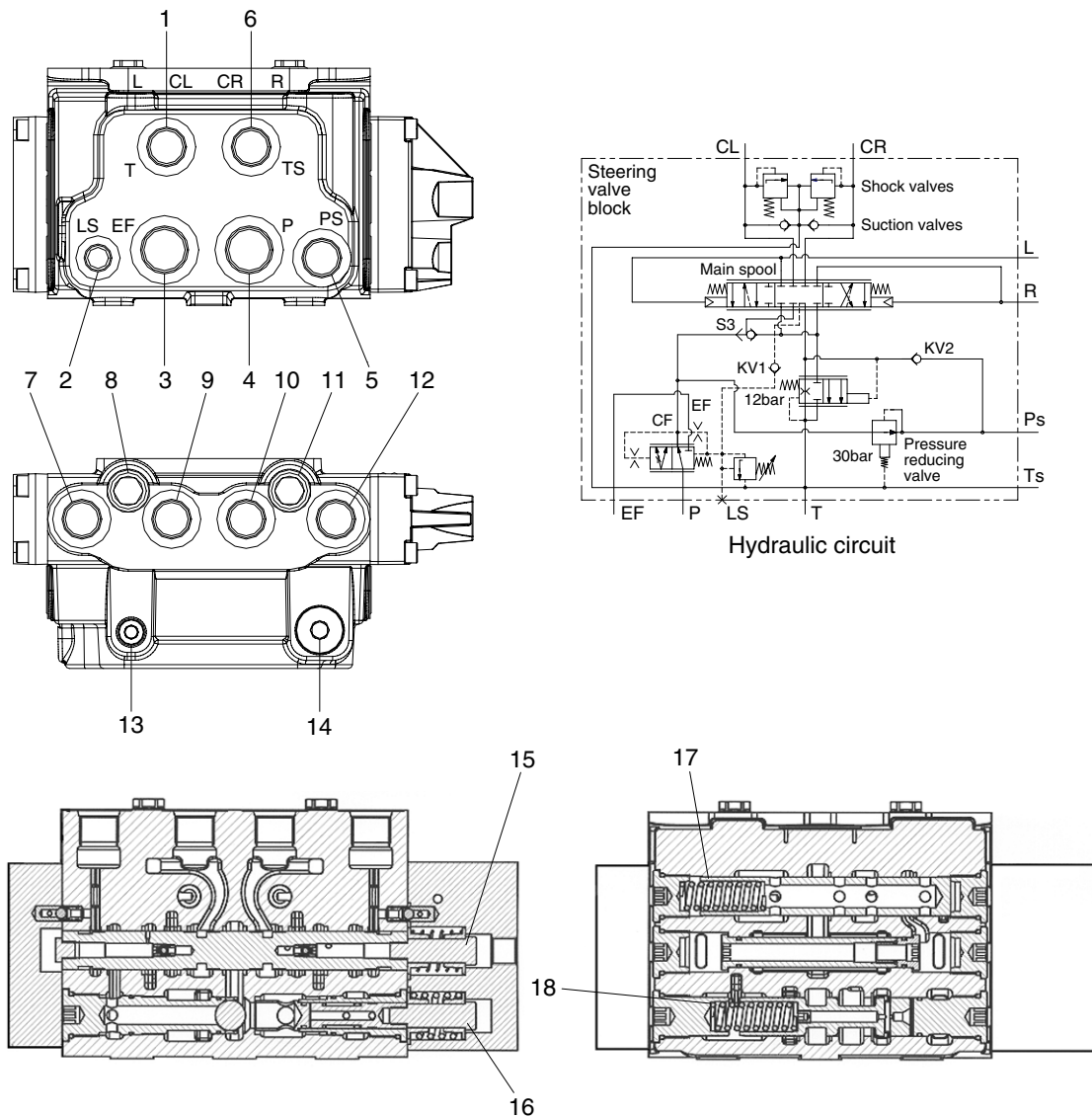

7607SE11

- |                             |                                      |                            |
|-----------------------------|--------------------------------------|----------------------------|
| 1 To tank                   | 7 From steering unit L port          | 13 Relief valve            |
| 2 To emergency system       | 8 Shock & suction valve(Left side)   | 14 Check valve             |
| 3 To main control valve     | 9 To steering cylinder(Left side)    | 15 Main steering spool     |
| 4 From main pump            | 10 To steering cylinder(Right side)  | 16 Pressure reducing valve |
| 5 To steering unit P port   | 11 Shock & suction valve(Right side) | 17 Metering spool          |
| 6 From steering unit T port | 12 From steering unit R port         | 18 Priority spool          |





### (3) Turning right

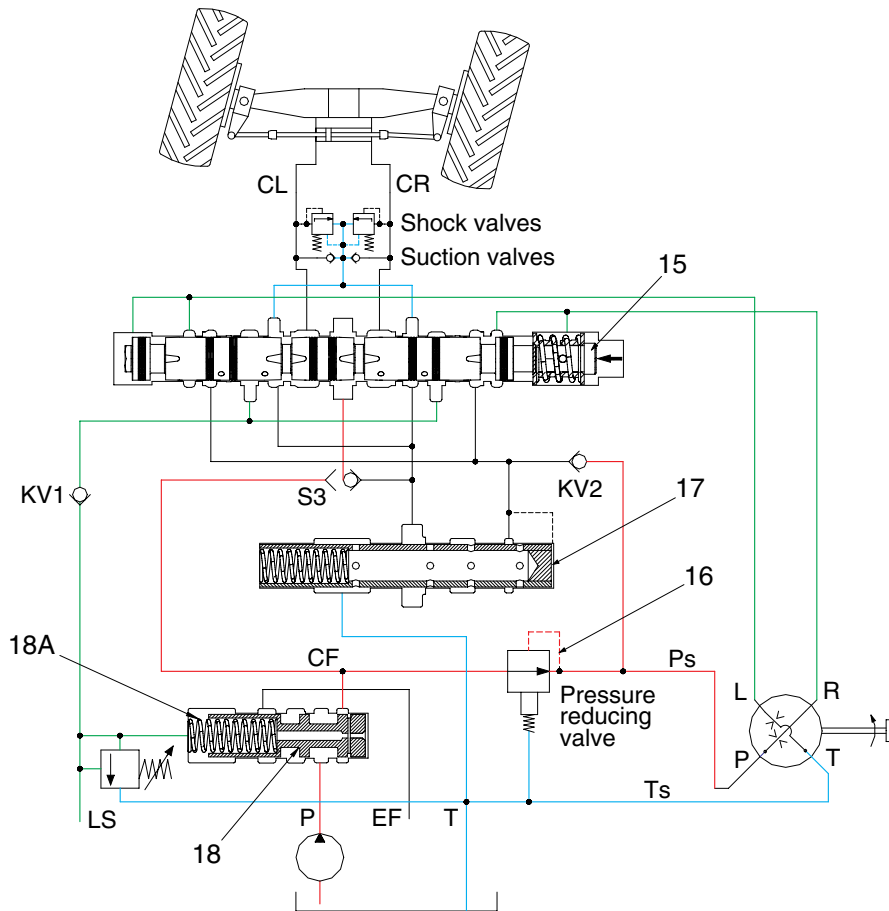

7607SE14

- When the steering wheel is turned to the right, the pressure oil from the steering unit fill on the right side chamber of main steering spool(15), and main steering spool(15) moves to the left in the direction.
- At the same time of moving of main steering spool(15), LS signal will be blocked.
- If LS signal of main steering spool(15) is blocked, it cause to increase pressure of left chamber of priority valve(18A) and then priority valve(18) to be pushed to right side. Consequently, oil will flow via CF of priority valve to main spool. that oil will push steering cylinder rod out and it will cause wheel loader to be steered to right side.
- The rate of movement of main steering spool(15) is concluded as flow rate, which is kept in right chamber from steering unit. Furthermore the rate controls speed of movement for cylinder.
- When the cylinder reaches to end position, pressure of oil flowing through main steering spool(15) will get to be increased. If the oil pressure increase up to relief pressure to be set, relief valve will be activated. It result in decreasing pressure of left chamber of priority valve(18A), and will push priority valve(18) to right side. Then, oil flow to cylinder will be blocked.

#### (4) Pressure reducing valves

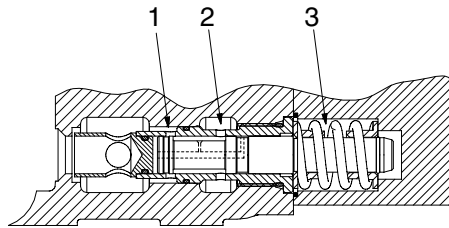

7607SE15

- Pressure reducing valve is a valve, which is supplying pilot oil to steering unit. That is one of advantage of steering system adopting steering valve.
- Pressure reducing valves are pressure-limiting devices that limit pressure in one portion of a circuit while leaving system pressure unaffected. Pressure reducing valves allow flow to pass from (1) to (2) until the pressure at (1) reaches the predetermined setting, at which point the spool shifts to restrict input flow from (1) (reducing mode) or to open flow from (2) to (3) (relieving mode) as needed to maintain the regulated pressure at (2).

#### (5) Relief valve

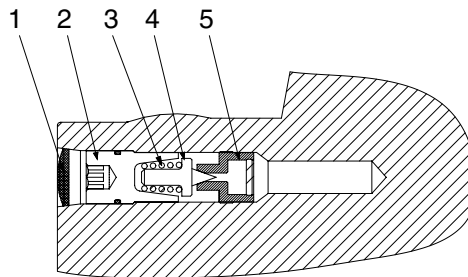

7607SE16

- |   |                  |   |            |
|---|------------------|---|------------|
| 1 | Plastic plug     | 4 | Thrust pad |
| 2 | Adjustment screw | 5 | Valve seat |
| 3 | Spring           |   |            |

#### FUNCTION

The main relief valve is inside the steering valve, and set the maximum circuit pressure of the steering circuit.

When the steering valve is being actuated, if the steering circuit goes up above the set pressure of this valve, oil will be relieved, the priority valve spool will be actuated, and the oil will be flow to EF port.

## 4. STEERING UNIT

### 1) STRUCTURE

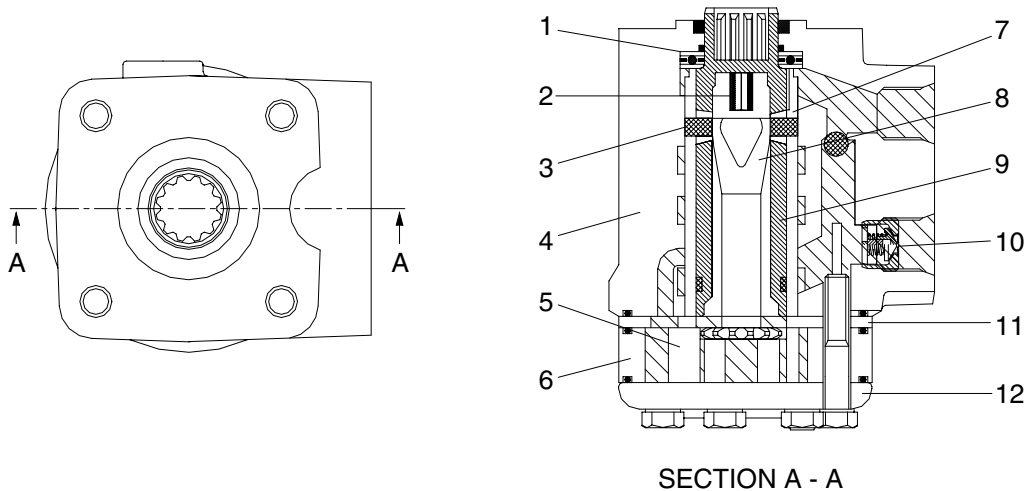

1	Bearing	5	Gear wheel	9	Spool
2	Neutral position spring	6	Gear rim	10	Check valve
3	Cross pin	7	Sleeve	11	Distributor plate
4	Housing	8	Cardan shaft	12	End cover

### 2) OPERATION

The steering unit consists of a rotary valve and a rotary meter.

Via a steering column the steering unit is connected to the steering wheel of the machine.

When the steering wheel is turned, oil is directed from the steering system pump via the rotary valve (spool and sleeve) and rotary meter (gear wheel set) to the cylinder ports L or R, depending on the direction of turn. The rotary meter meters the oil flow to the steering cylinder in proportion to the angular rotation of the steering wheel.

Spool(9) is connected directly to the drive shaft of steering wheel. It is connected to sleeve(7) by cross pin(3) (not in contact with the spool when the steering wheel is at neutral) and neutral position spring(2).

Cardan shaft(8) is meshed at the top with cross pin(3) and forms one unit with sleeve(7).

At the same time, it is meshed with gear rim(5) of the gerotor set by spline.

There are four ports in valve body. They are connected to the pump circuit, tank circuit, and the head, and left and right steering cylinder. In addition, the pump port and tank port are connected inside the body by the check valve. Therefore, if there is any failure in the pump of engine, oil can be sucked in directly from the tank through the check valve.

7607SE17

## 5. CUSHION VALVE

### 1) STRUCTURE

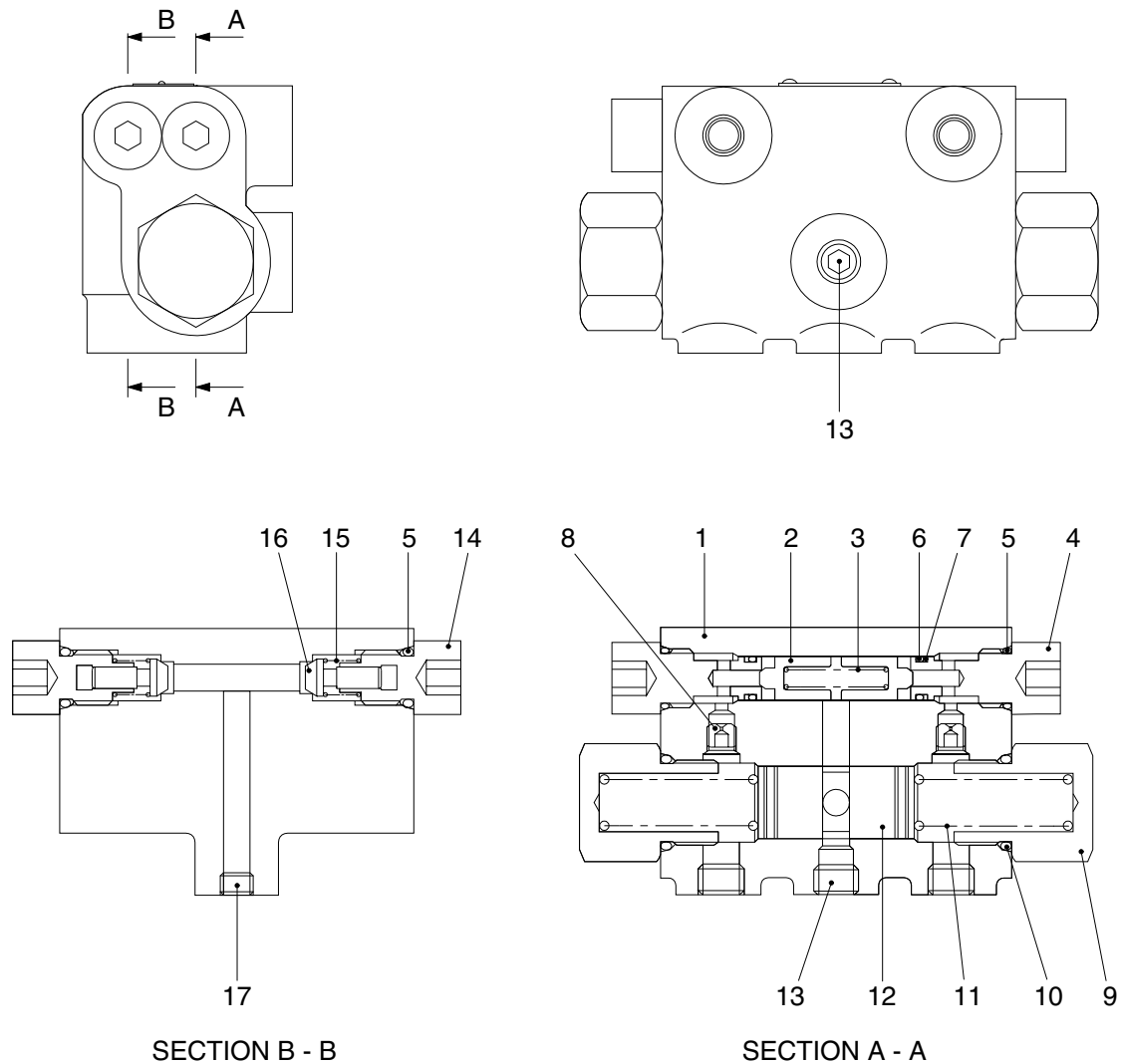

SECTION B - B

SECTION A - A

7607SE18

- |   |            |    |           |    |        |
|---|------------|----|-----------|----|--------|
| 1 | Housing    | 7  | Back ring | 13 | Plug   |
| 2 | Poppet     | 8  | Orifice   | 14 | Plug   |
| 3 | Spring     | 9  | Plug      | 15 | Spring |
| 4 | Valve seat | 10 | O-ring    | 16 | Poppet |
| 5 | O-ring     | 11 | Spring    | 17 | Plug   |
| 6 | O-ring     | 12 | Spool     |    |        |

## 2) OPERATION

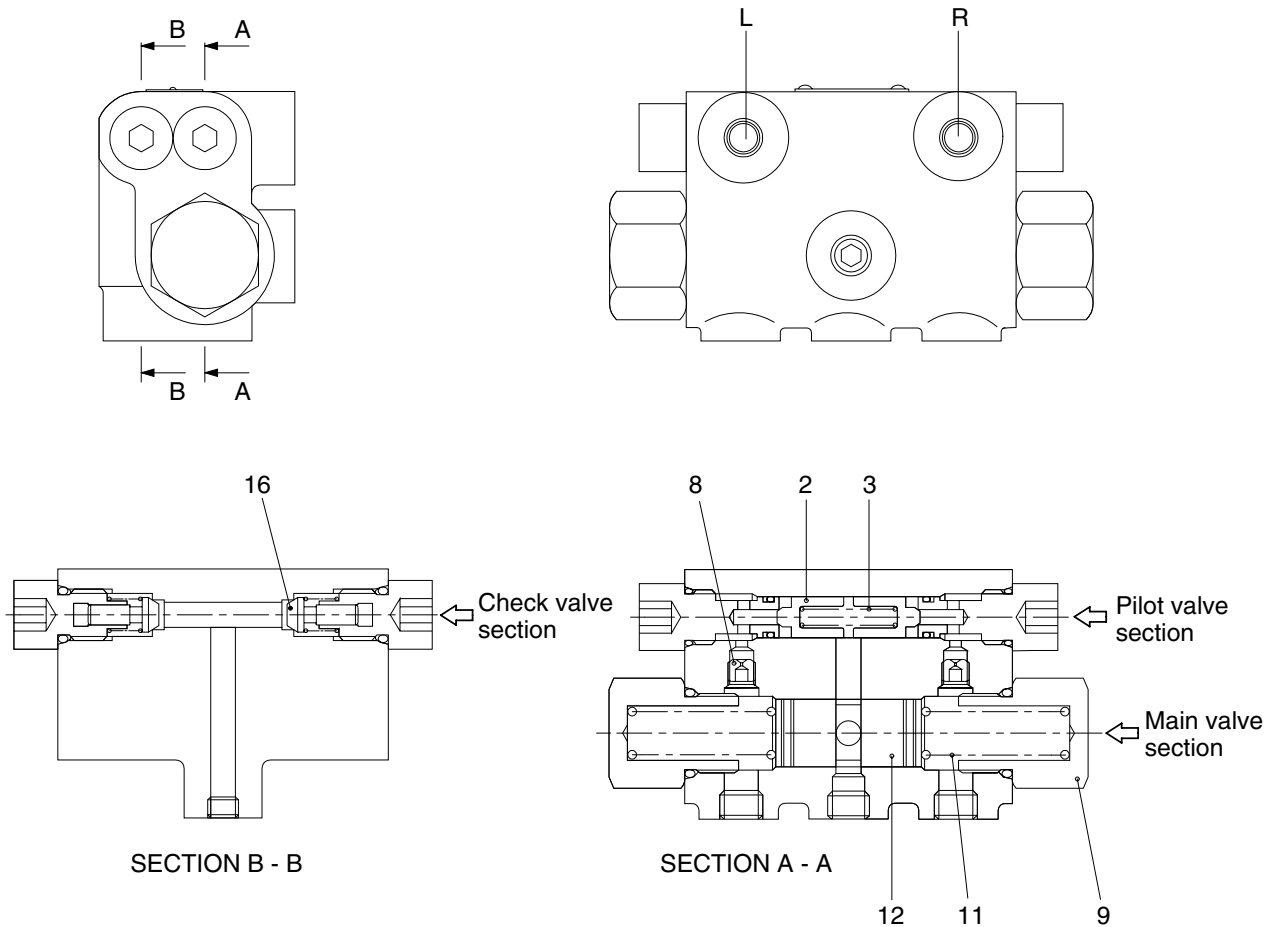

7607SE19

The cushion valve is a valve that eliminates steering jerk motion. It makes a higher pressurized oil to flow into another line in order to prevent the shock on steering system.

The pressure by rapid supplied pressurized oil from R port is higher than the spring(3) force, so it press and open the poppet(2). Then the oil flows to the central groove of the spool(12), and flows to L port through the poppet of the check valve(16) on L port side.

At this time, this pressurized oil flows to the pressure area of the plug(9) through the orifice(8), and this force is higher than the spring(11) force plus the oil pressure on L port side, so the spool(12) is shifted to the right. The flow of the supplied oil to L port side through the poppet(2) from R port side is trapped. The flow of this instant oil makes the function of the cushion. After this operation, the normal steering operation is not affected because this valve is not operated any longer.

Also, for the response of the pressure when the operation is slow as a cushion effect is not required, the spool(12) is closed before the poppet(2) is opened, so this valve is not operated.

## 6. STEERING CYLINDER

### 1) STRUCTURE

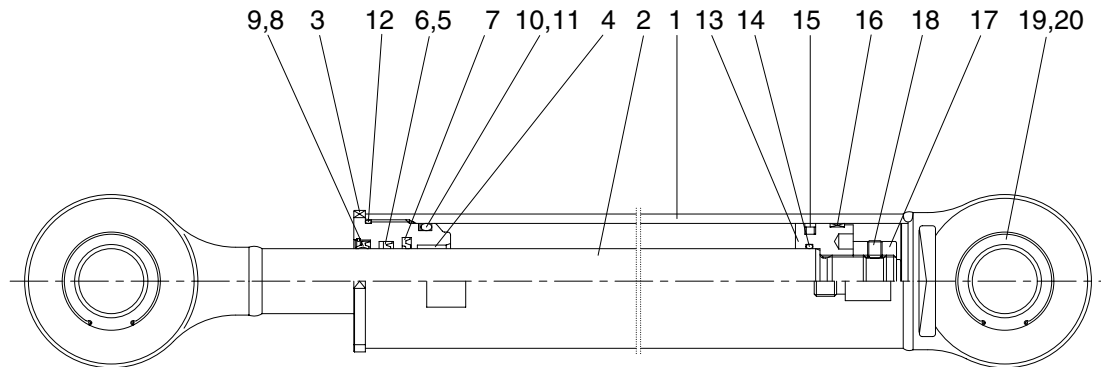

7607SE05

1	Tube assembly	8	Dust wiper	15	Piston seal
2	Rod assembly	9	Snap ring	16	Wear ring
3	Gland	10	O-ring	17	Lock nut
4	Bushing	11	Back up ring	18	Set screw
5	Rod seal	12	O-ring	19	Spherical bearing
6	Back up ring	13	Piston	20	Retaining ring
7	Buffer ring	14	O-ring		

### 2) OPERATION

This machine use to cross connected cylinder for steering operation.

The steering cylinder use a gland(3) to remove piston and sealed seals. Dust wiper(8) located on the in side of the gland protects cylinder inner parts from dust. The piston(13) is fastened to the rod(2) by a nut(17).

The piston uses a single wear ring(16) with a piston seal(15) to seal between the piston and tube. The gland seals against the tube with two O-rings. The rod is sealed against the gland with a rod seal(5).