

3. VOLVO AXLE (Machine serial No. ; ~#0293)

1) GENERAL INSTRUCTIONS

(1) SHIMS

All adjustments shall be carried out after all adjustment shims have been selected measuring them one by one with a micrometer gauge and, then, summing up all values measured; don't trust incorrect measurement of pack as a unit or sum of nominal value printed on each shim.

(2) SEALS FOR REVOLVING SHAFTS

Proceed as follows for proper fitting of captioned seals:

- ① Prior assembly, seals should be kept, for at least half an hour, in a bath with the same oil to be sealed;
- ② Clean thoroughly shaft and make that working surface be not damaged;
- ③ Position sealing lip against the fluid to be sealed; in case of hydrodynamic lip lines should be oriented so as that, considering direction of revolving shaft, they lead fluid inside of sealing means;
- ④ Smear sealing lip with a film of lubricant(oil is better than grease) and fill up with grease the space between sealing lip and dust shield lip, if using double sealing lip type seals;
- ⑤ Press seal in relevant seat or use a proper fitter with flat contact surface; never use hammer or mallet to mount seal;
- ⑥ When press fitting seal make sure that it be correctly driven in relevant seat, i.e., perpendicular with respect to its seat, as fitting is completed make sure, if required, that seal itself be in contact with relevant shoulder;
- ⑦ To prevent damage of seal lip when inserting shaft, duly protect component during assembly.

(3) O-RING SEALS

Lubricate O-RING seals at assembly to prevent twisting that would impair correct sealing.

Clean matching surface as follows prior, smearing compound:

- ① Remove old deposits using a metal brush;
- ② Degrease surfaces by one the following cleaners: trichloroethylene, kerosene or a warm water and soda solution.

(4) BEARINGS

When assembling them it is advisable to proceed as follows:

- ① Heat them with 80 to 90°C before fitting on relevant shafts;
- ② Cool them before inserting in relevant external seats.

(5) SPRING PINS

When using split pins be sure that lengthwise cleft be positioned toward stress on pin.

Coil pins don't require specific position.

2) REDUCTION ASSEMBLY

(1) DISASSEMBLY

- ① Turn the plug toward top position and remove the plug for the air vent. Assemble the plug temporarily.

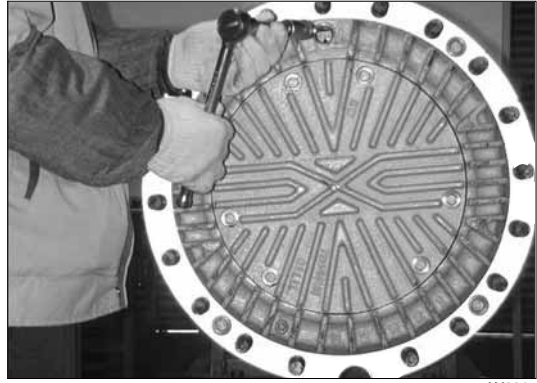

AX001

- ② Drain oil from final drive unit.

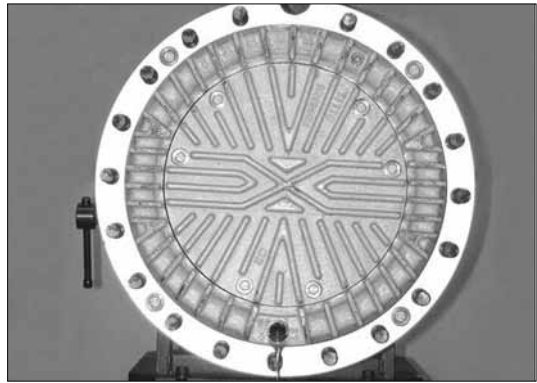

AX002

- ③ Loosen screws securing side gear carrier to wheel hub.

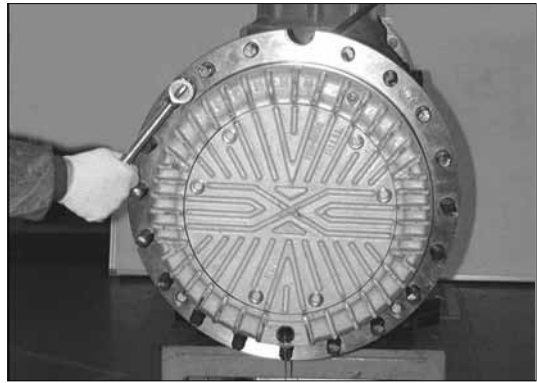

AX003

- ④ Pull out complete side gear carrier.

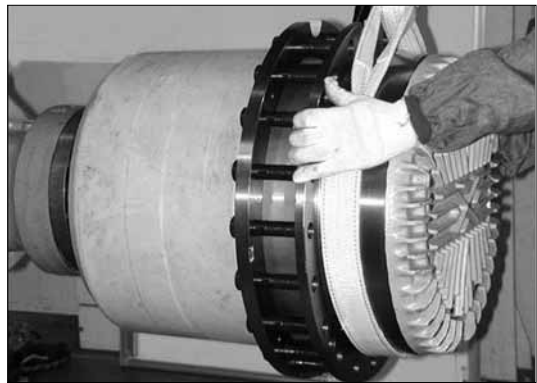

AX004

- ⑤ Pull out wheel shaft with sun gear, discs carrier hub and thrust plate.

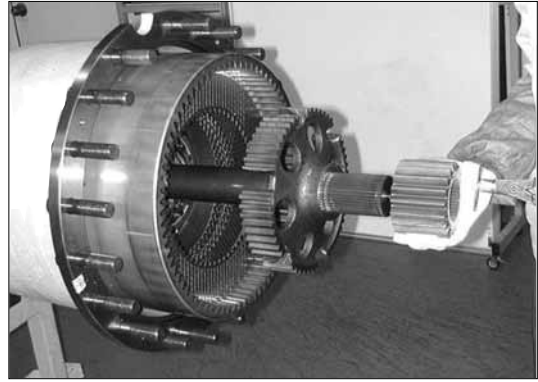

AX005

- ⑥ Remove brake disc pack.

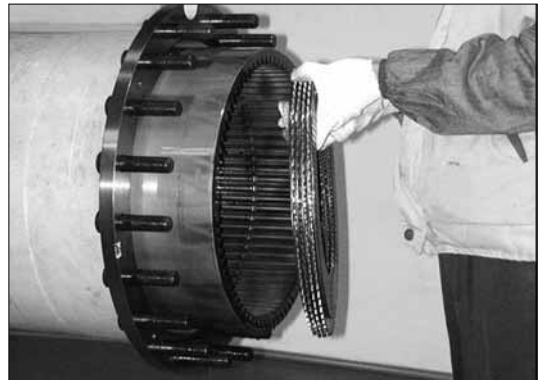

AX006

- ⑦ Remove lock ring nut locks.

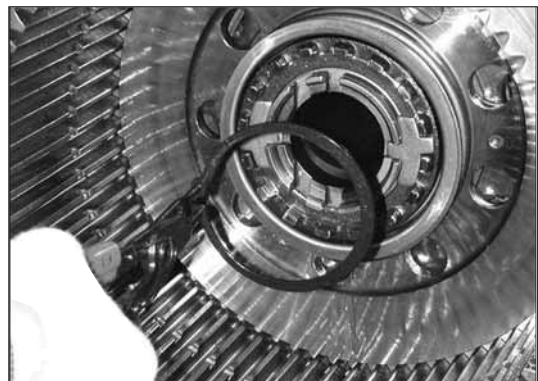

AX007

- ⑧ Remove locks.

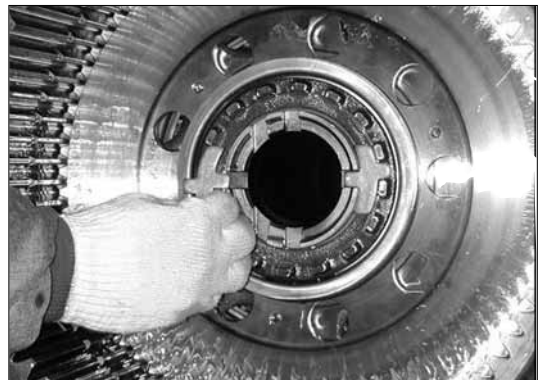

AX008

- ⑨ Install the proper tool on pressure plate and apply the eye bolt(3EA) temporarily. Tighten the eye bolt tool perfectly.

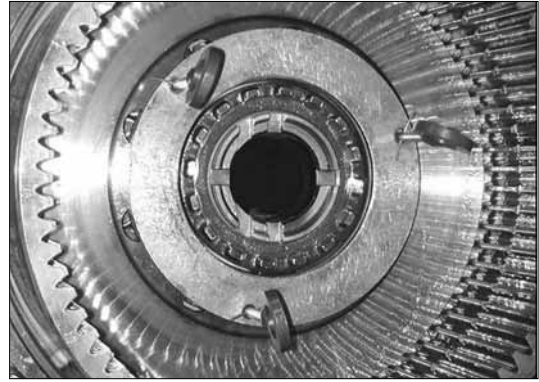

AX009

- ⑩ Remove the adjusting nut by the use of the special tool.

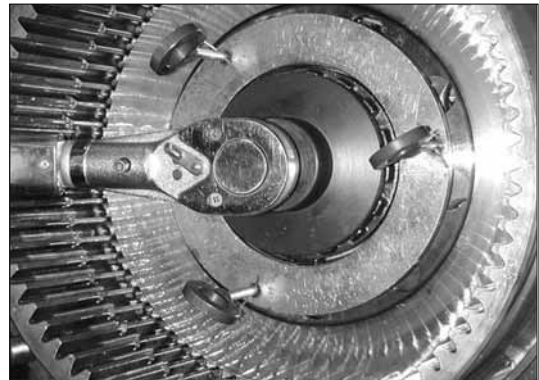

AX0010

- ⑪ Remove the pressure plate, return spring, cover and compression tool.



AX0011

- ⑫ Remove the ring gear assembly.

※ Attention to the weight.



AX0012

- ⑬ Pry off lock ring from ring gear by a screw driver and remove ring gear support.

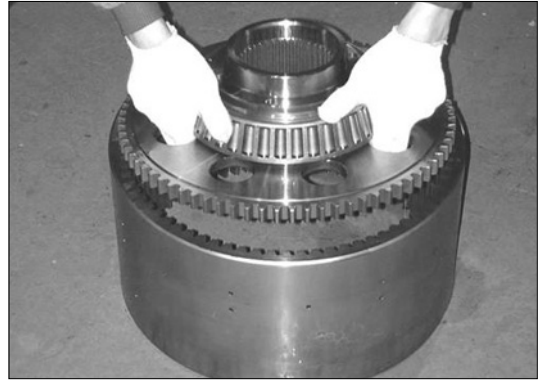

AX0013

- ⑭ Remove piston, it's easier by blowing compressed air in brake oil delivery ducting.

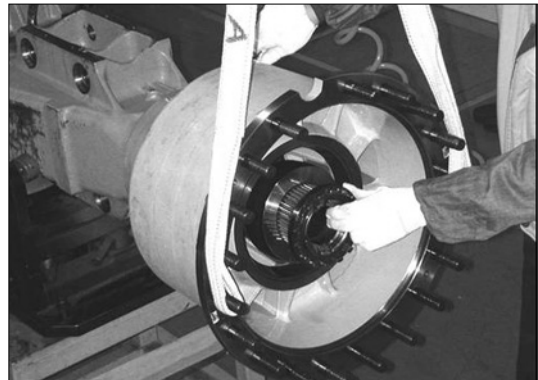

AX0014

- ⑮ Remove wheel hub assembly.

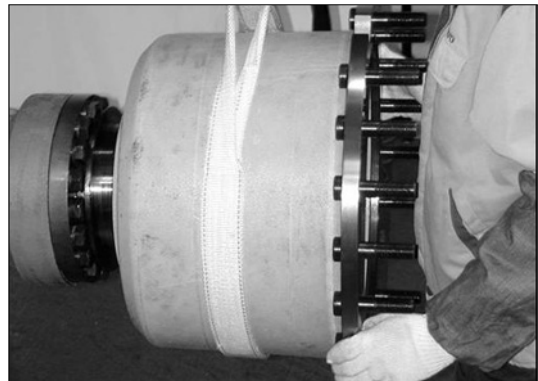

AX0015

- ⑯ Pry off wheel hub seal and remove inner race with roller cage of wheel inside bearing. By using a punch remove from wheel hub outer races of inner and outer bearings.



AX0016



AX0017

⑰ Remove final drive cover.

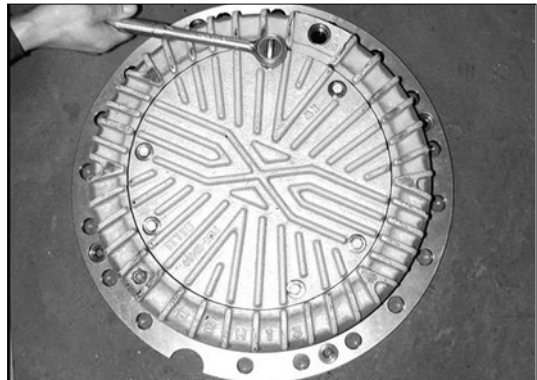

AX0018

⑱ It is provided with three threaded holes (M10 × 1.5) to be used for puller screws.

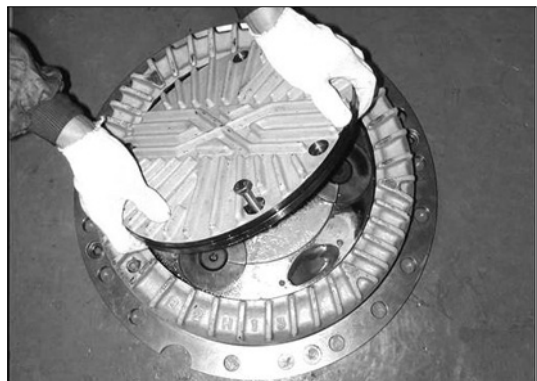

AX0019

⑲ Remove the planetary pin(3EA) from hub drum(Side gear carrier support) assembly.



AX0020

- ⑳ Remove the planetary gear and thrust washer step by step.

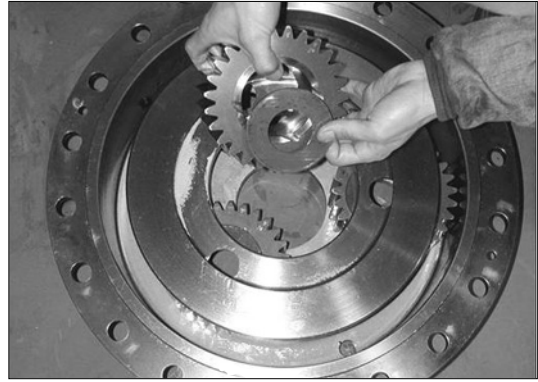

AX0021

(2) ASSEMBLY

- ① Insert the inner bearing cone.



AX085

- ② Press fitting lip seal.

- ※ Smear loctite 573 or equivalent sealant on outer diameter surface.



AX086

- ③ Support suitably wheel hub while assembling parts to prevent damage of seal; then go on by fitting wheel bearing on hub spindle.

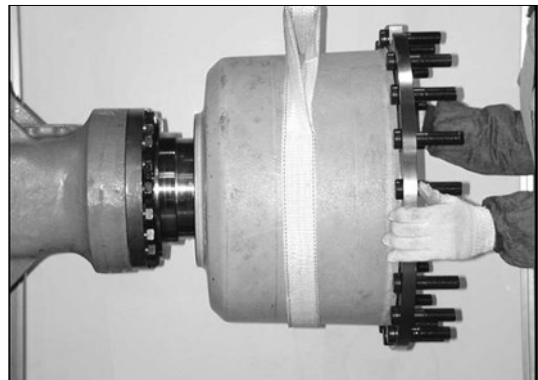

AX087

④ Replace O-ring seals on piston.

※ Cover the oil on O-ring seal enough.



AX088

⑤ Insert piston full travel down on hub spindle.



AX089

⑥ Insert ring gear support in ring gear, then fit spring ring retaining axle.



AX090

⑦ Mount on hub spindle the complete ring gear unit.

※ Attention to the weight.



AX091

- ⑧ Insert into relevant holes the six pins that, for proper operation of whole system, have to be of the same length and however in accordance with relevant drawing.

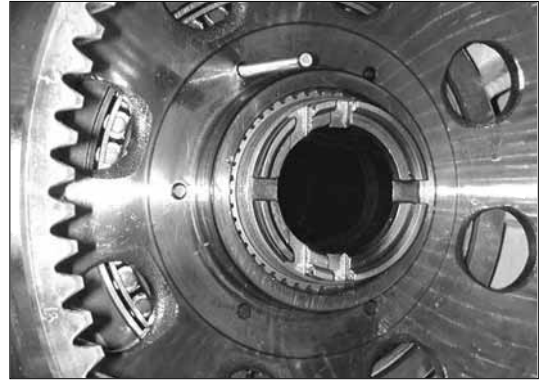

AX092

- ⑨ Position return spring, cover and spacer on pressure plate, press compression tool. (Front axle only)

※ There is not spacer to the rear axle.



AX093

- ⑩ Assemble support assembly with spring compression tool on spindle and tighten adjusting nut.



AX094

- ⑪ With proper wrench lock ring so to reach the specified wheel bearing pre-load corresponding to a rotation torque and a rope pull strength on studs included into 15~18kg.

To prevent wrong torque recording, it is advisable to set bearings, by various wheel revolutions, prior performing the check.

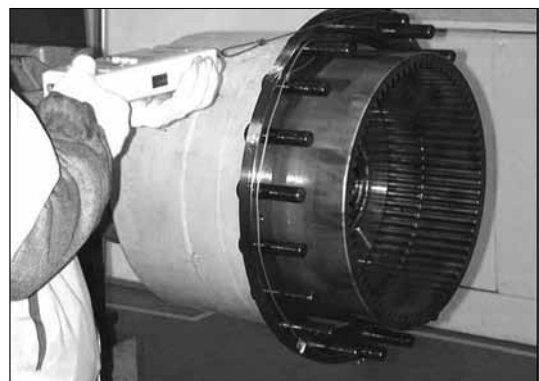

AX095

⑫ Remove spring compression tool.



AX096

⑬ Fit plate and assemble retain ring.

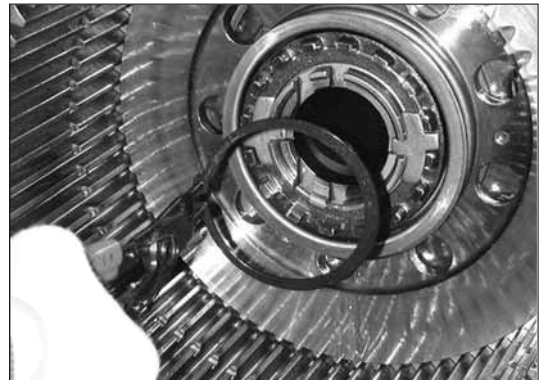

AX097

⑭ Insert wheel shaft on which sequentially mount ; the thrust washer, discs carrier hub, sun gear and lock ring ; then push all components fully down against hub spindle.

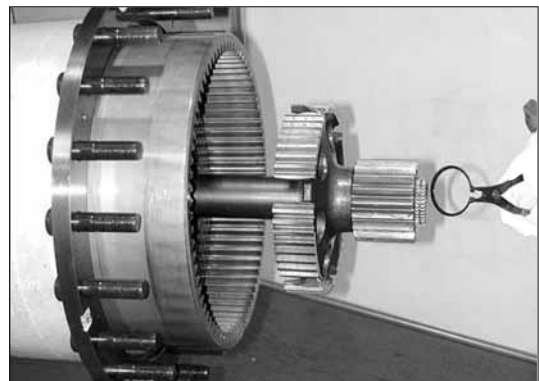

AX098

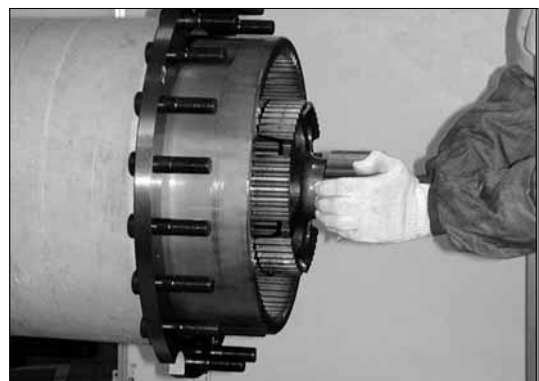

AX099

⑮ Install brake measuring tool on wheel hub.

※ Distance of brake measuring tool J

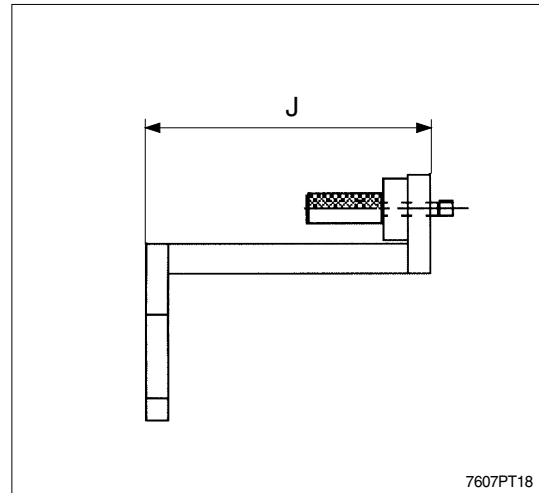

⑯ Measure K between end of measuring tool and pressure plate.

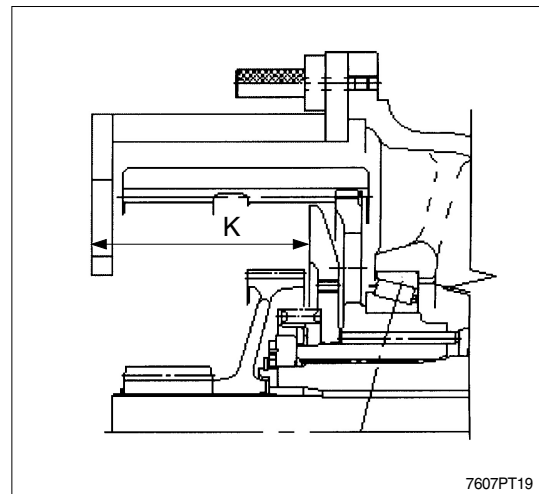

⑰ Install brake measuring tool on hub drum and measure L.

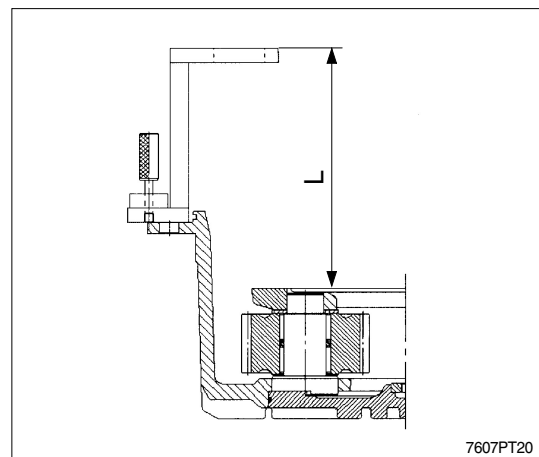

⑱ To determine thickness of disc pack from previously computed value **M**.

※ Assembly procedure of brake disc pack :
To hub drum from pressure plate **C, B, C, B.....C, B.**(C=disc-count, B=disc-brake)

※ Quantity of brake disc.

- Front axle : disc-count 5EA
disc-brake 5EA
- Rear axle : disc-count 4EA
disc-brake 4EA

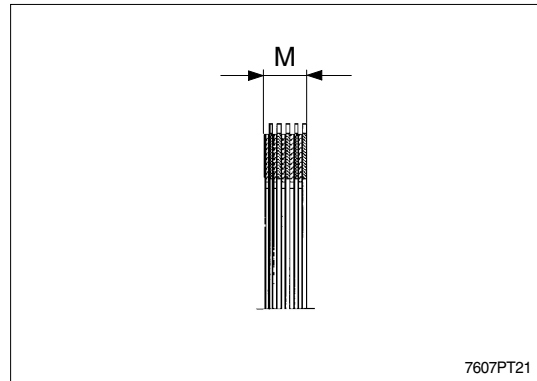

7607PT21

⑲ Calculate stroke, and if it is not satisfied with the specification, readjust stroke by means of change the thickness of each disc.

$$\text{Stroke} : S = (K + L - 2J) - M$$

· Stroke

Front axle : 3.5~4.0mm

Rear axle : 3.6~4.0mm

⑳ Assemble disc pack according to the procedure.

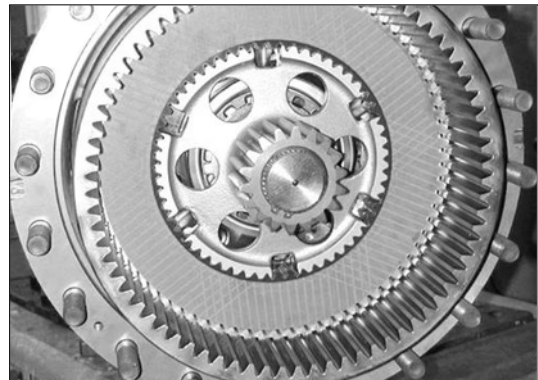

AX104

㉑ Arrange side gear carrier on blocks made of wood and remove pins.

Save needle rollers of filling bearing casings. It is important to keep needle rollers joined with relevant pin for allowance question of pins themselves.



AX105

- ② Arrange all the three side gears into relevant seats of side gear carrier, position inner thrust washers and align holes.

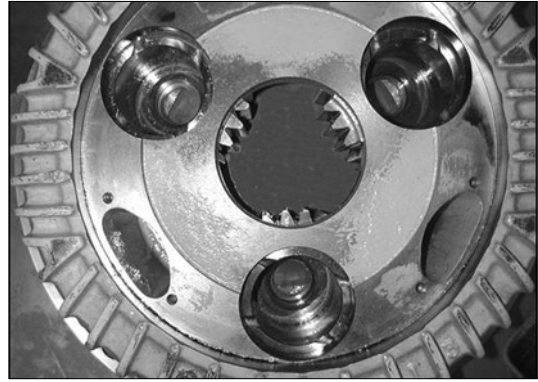

AX106

- ③ Mount on pins the two needle roller casings. Insert outer thrust washers, grease lower half of pin(head side) and position the first needle roller casing, insert spacer and position the second casing.

- ※ In case of needle roller replacement, use needle roller of the same selection class for the two casings of each side gear.

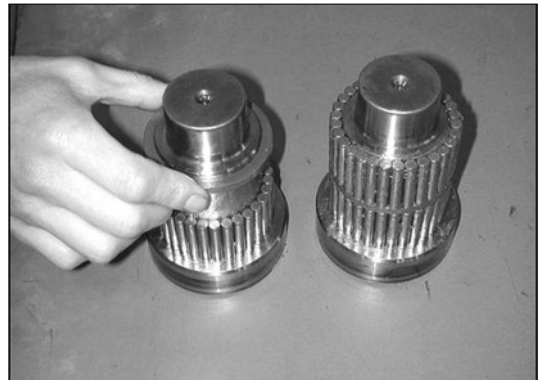

AX107

- ④ Insert the complete pins, taking care to avoid any bump, cause of needle rollers fall.



AX108

- ⑤ Rotate pins so to align them and allow fitting of cover that also prevent pin rotation.

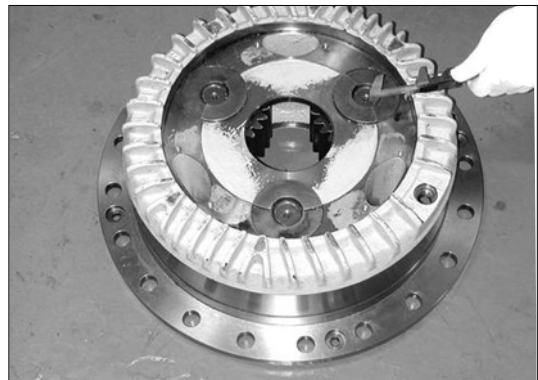

AX109

Fit O-ring seal on outer side.
Mount side cover on final drive.

- Tightening torque
Front and rear axle : 2.9~3.6kgf · m
(21.0~26.0lbf · ft)

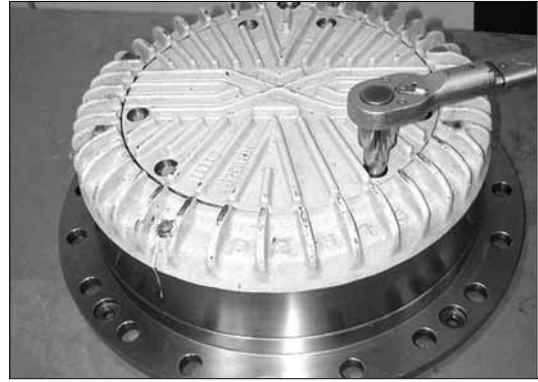

AX110

Assemble hub drum on wheel hub.

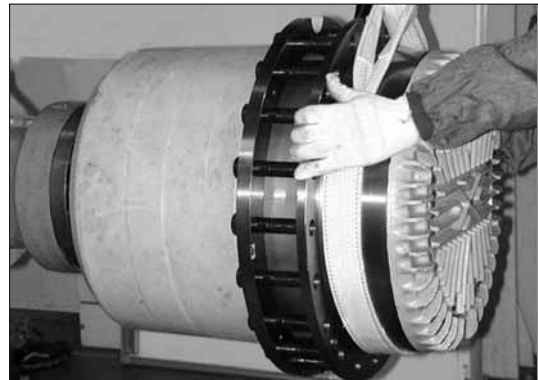

AX111

Tight the fixed bolt of hub drum and assemble plug.

- Tightening torque
Front and rear axle : 6.3~6.9kgf · m
(45.6~50.0lbf · ft)

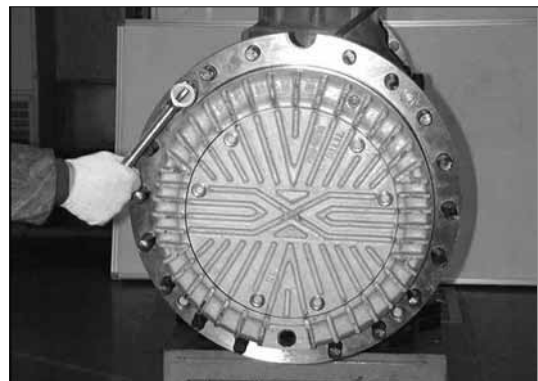

AX112

3) PARKING BRAKE(FRONT AXLE ONLY)

(1) DISASSEMBLY

- ① Insert through oil adding hole of gripper the pressure of 100~120bar, in order to obtain calipers release.

Remove the cover bolts of caliper.

- Brake port size : 7/16" -20UNF O-ring type



Front

AX022

- ② Release nut and screw.

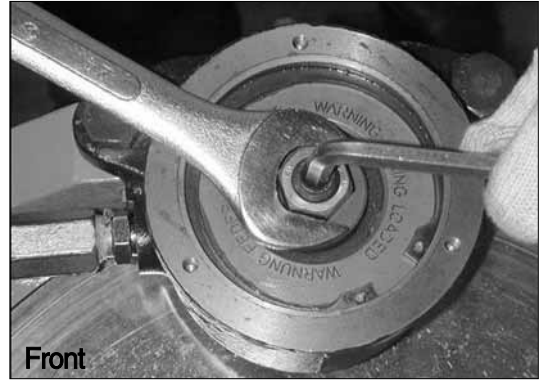

AX023

- ③ Remove the split pin and nut of caliper brake. Remove the bolts.

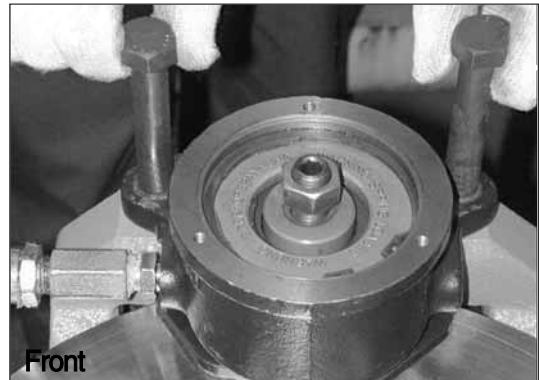

AX024

- ④ Remove the caliper brake.

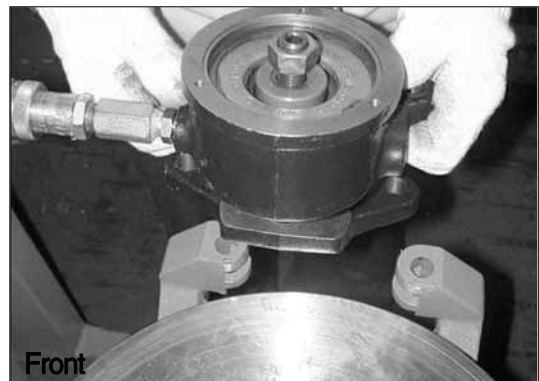

AX025

- ⑤ Remove the disc.

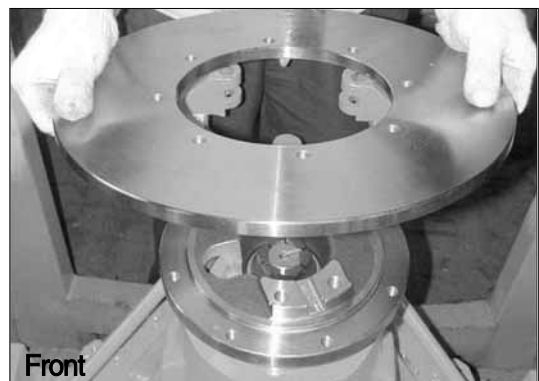

AX026

- ⑥ Remove the fixed bolts of caliper bracket.



AX027

(2) ASSEMBLY

- ① Install caliper bracket.

- Tightening torque
14.2~15.7kgf · m(103~114lbf · ft)

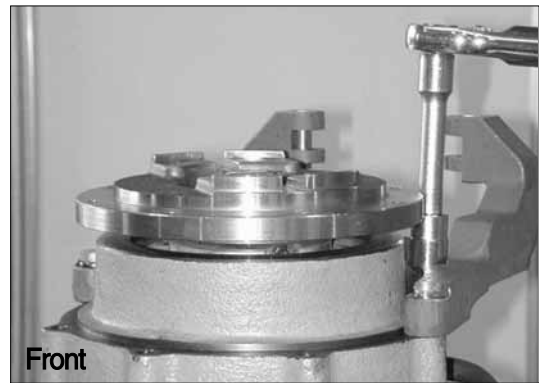

AX113

- ② Fit disc on flange, and tighten bolts.

- Tightening torque
6~7kgf · m(43.4~50.6lbf · ft)

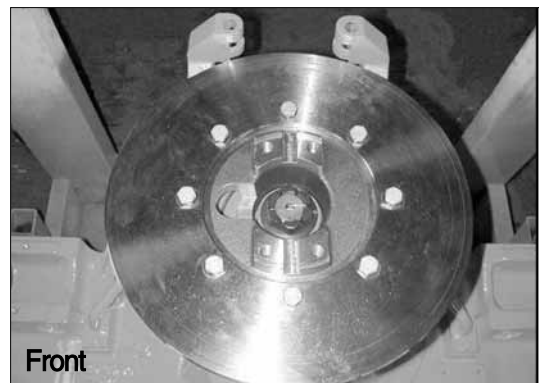

AX114

- ③ Remove cover and O-ring of caliper bracket, and release nut and pin screw.

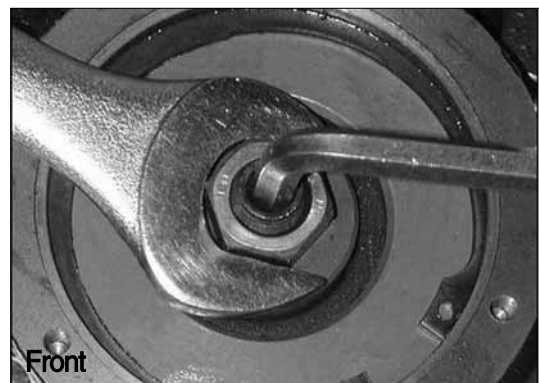

AX115

- ④ Release nuts on fixed bolts in order to obtain the maximum opening of gripper.

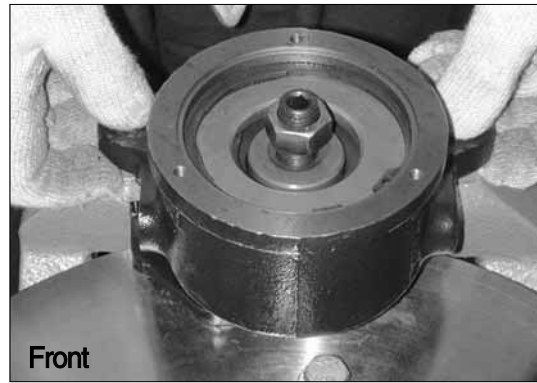

AX116

- ⑤ Insert fixed bolts on caliper bracket.

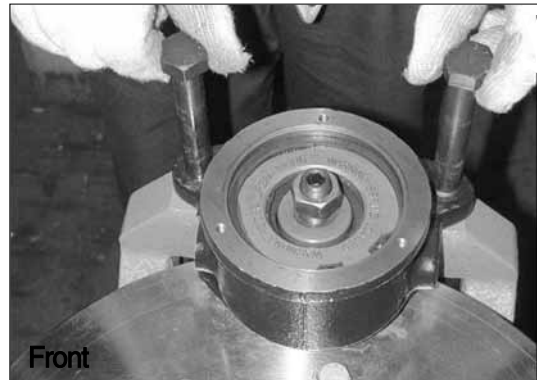

AX117

- ⑥ Tighten nuts and split pins.
· Tightening torque
1~3kgf · m(7.2~21.7lb · ft)

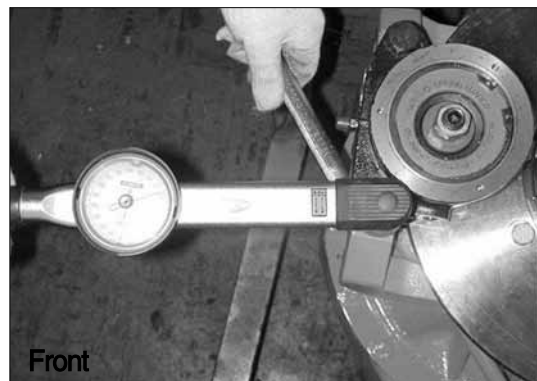

AX118

- ⑦ Assemble the bleeder on brake caliper.
· Bleeder tightening torque : 1.4~1.5kgf · m
(10.1~10.8lb · ft)

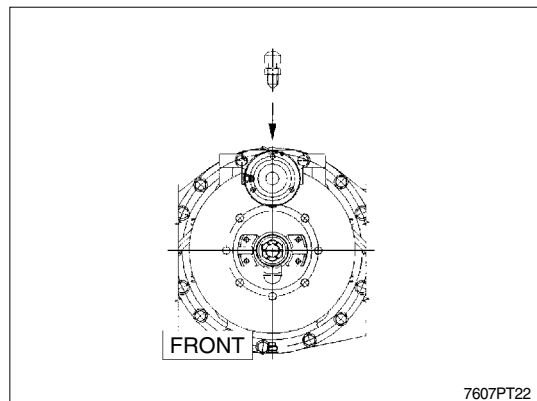

7607PT22

- ⑧ Press 110~120bar in brake port and close
adhesion pad on disc by means of
tightening screw pin.

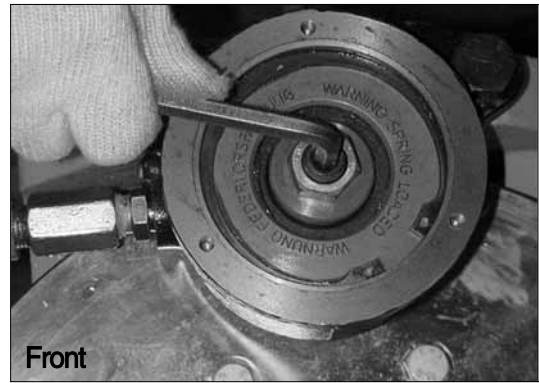

AX120

- ⑨ Check the gap between discs after unscrew-
ing pin screw 1/8~1/4turn.

※ Disc gap : Each 0.125~0.25mm

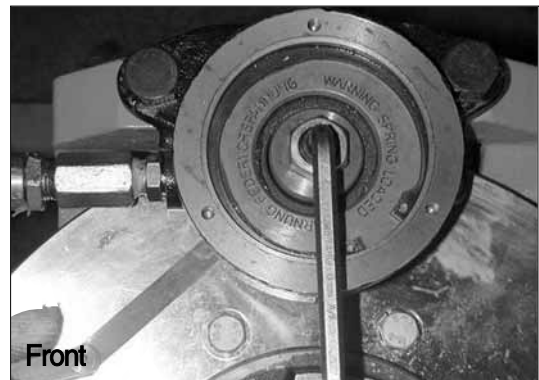

AX121

- ⑩ Tighten nut.

· Tightening torque : 14~16kgf · m
(101~116lbf · ft)

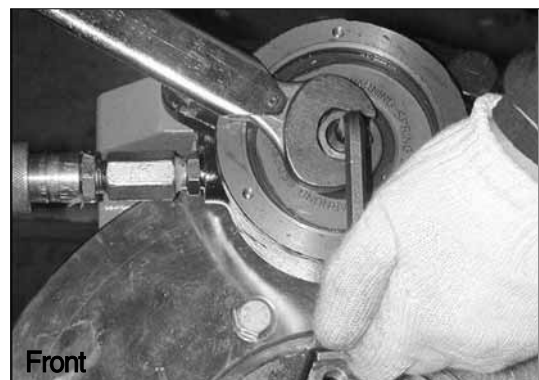

AX122

- ⑪ Tighten bolts after assembling O-ring on
cover.

· Tightening torque : 1.3~1.5kgf · m
(9.4~10.8lbf · ft)

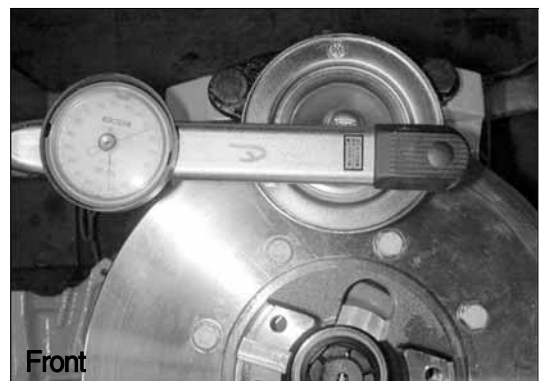

AX123

4) DIFFERENTIAL ASSEMBLY

(1) REMOVAL

- ① Remove screws and take away air recirculation duct from differential support and axle case.(Front axle only)



AX028

- ② Loosen the screws retaining differential group, then remove it from axle case.

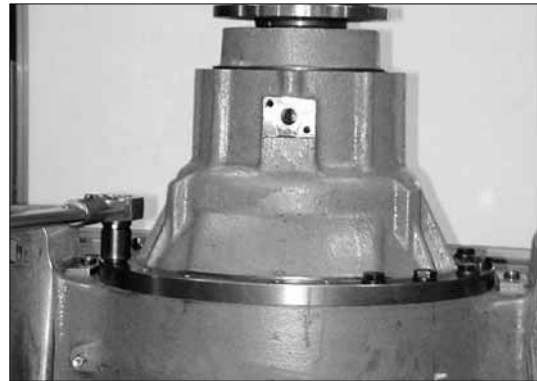

AX029

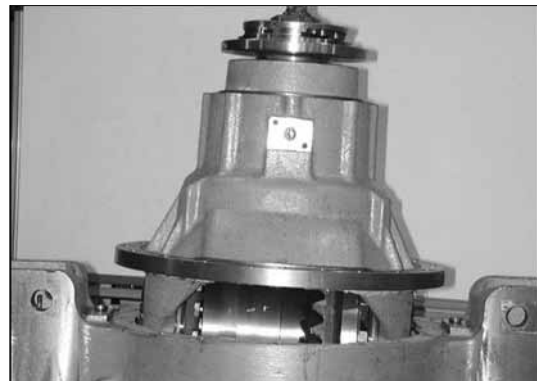

AX030

(2) DISASSEMBLY

- ① Place differential unit upside down; mark caps position.

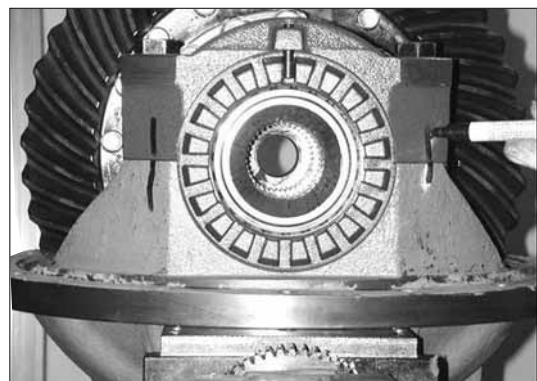

AX031

- ② Unlock and remove caps fixing screws.

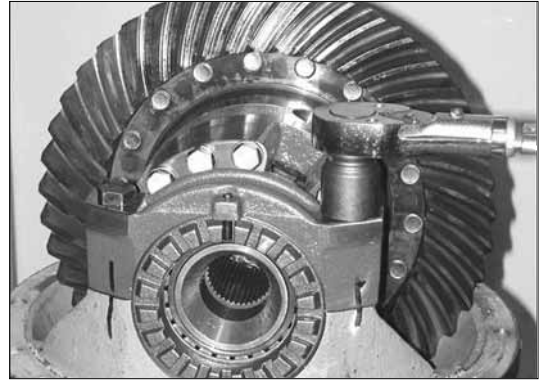

AX032

- ③ Remove lock pin of ring nut, remove caps.



AX033

- ④ Unlock nut and remove screw.
(Rear differential only)



7607AX130

- ⑤ Remove fixing screws(4EA) of cross beam
assembly. (Rear differential only)



7607AX131

- ⑥ Install the disassembling bolt on tap (M12×1.75, 2EA) of cross beam assembly.
(Rear differential only)

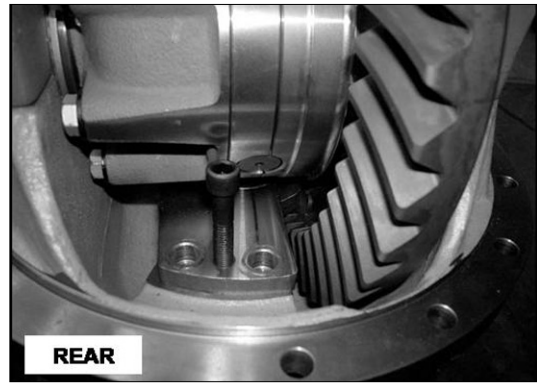

- ⑦ Lift up differential, cross beam assembly
(Rear differential only) from support, by a lifting tool with proper capacity.

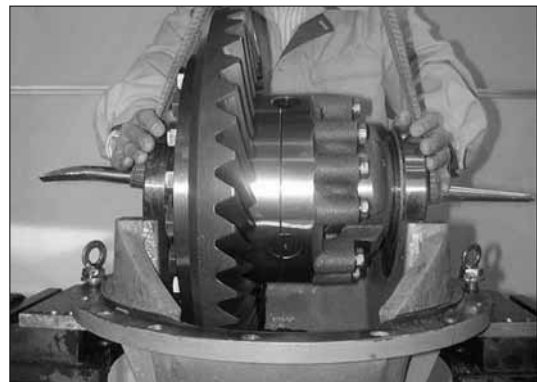

- ⑧ Remove pin, washer from cross beam assembly. (Rear differential only)



- ⑨ Remove bearing from cross beam. (Rear differential only)



- ⑩ Place on proper support and lock the differential. Straighten notches on pinion nut, then position reaction tool on P.T.O. flange and unlock nut; release pinion nut. Remove drive flange from pinion shank.

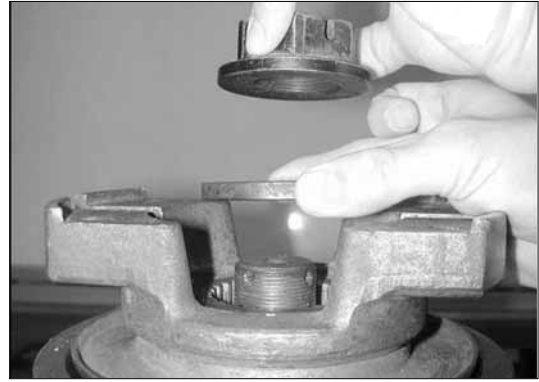

AX035



AX036

- ⑪ Pry off seal from P.T.O. flange.



AX037

- ⑫ Drive out bevel pinion from differential support hammering by a proper remover on shank, don't damage thread.



AX038

⑬ Remove the bearing cone.



AX039

⑭ Remove pump and shim.
(Front differential only)



AX135

⑮ Remove the shim and spacer in removed pinion. (Rear differential only)

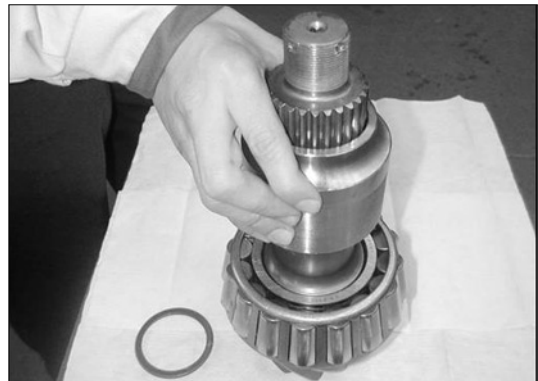

AX041

⑯ Remove shim and bearing cup from differential support, hammer pinion shank by a proper tool, taking care not to damage thread.



AX137

(3) ASSEMBLY

- ① Measure the dimensions for assembly position of pinion bevel.
Decide the dimension X(shim thickness) by the calculation.

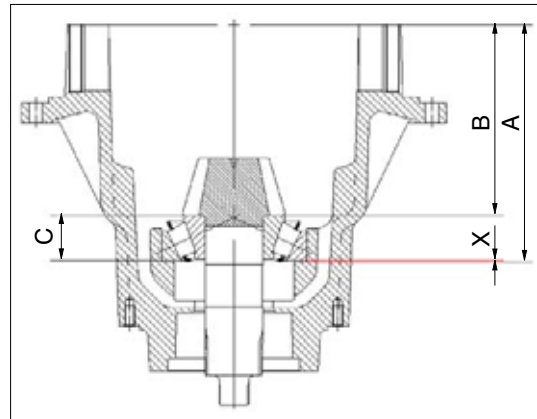

AX043

- ② Both the bevel pinion and the bevel gear are marked with a number. Confirmed the some numbers both the pinion-bevel and gear-bevel.
- ※ Number location of bevel set
Bevel pinion : Head surface
Bevel ring : Outer cutting side

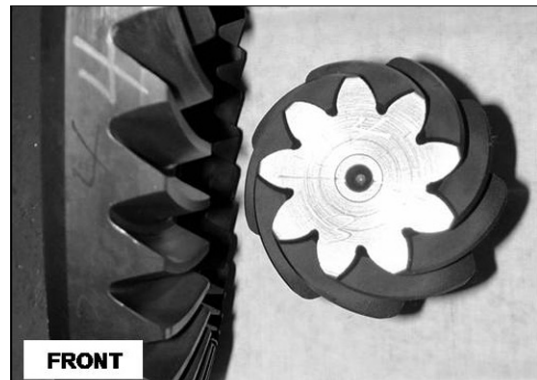

AX138



AX139

- ③ Measure the carrier height **A** by the special tool.

- ※ Standard value of **A**
- Front axle : 263.0mm
 - Rear axle : 222.0mm

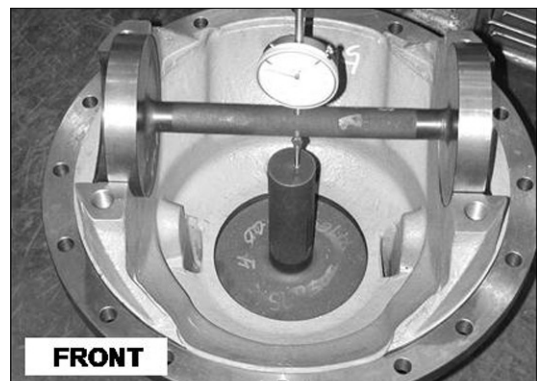

AX140

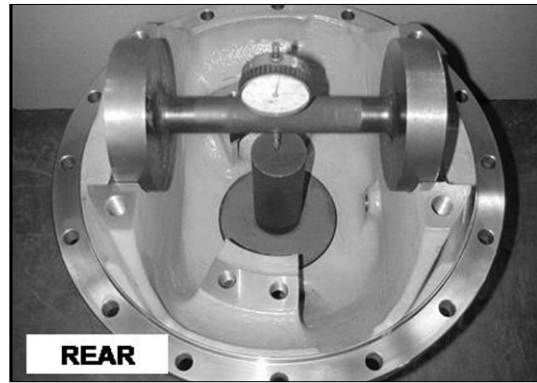

AX141

④ Decide a value **B** by the carved value of bevel pinion head.

- Front axle : $B = 208.0 \pm \text{carved value}$
- Rear axle : $B = 184.0 \pm \text{carved value}$

※ In case, the carved value is -10, **B** of Front axle = $208.0 - 0.1 = 207.9\text{mm}$

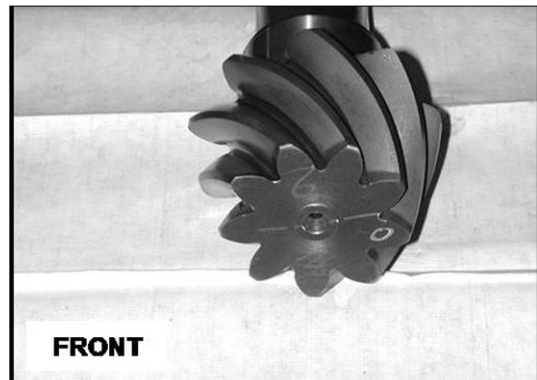

AX142



AX143

⑤ Measure the width of bearing **C**.

- ※ Standard value of **C**
 - Front axle : 54.0mm
 - Rear axle : 37.0mm

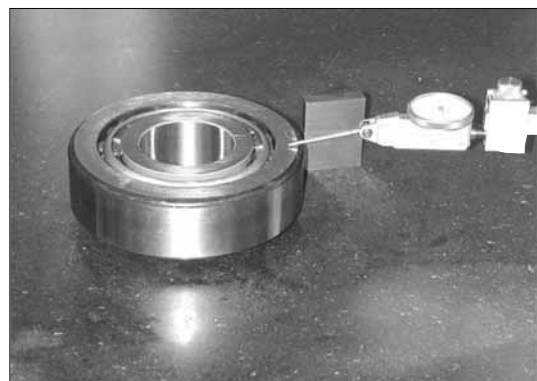

AX047

- ⑥ Determine shim X thickness for correct axial position of pinion-bevel.
 $X = A - (B + C)$

※ Round up or down to the nearest tenth of millimeter the computed thickness.

2.12 rounded down to = 2.1mm

2.18 rounded up to =2.2mm

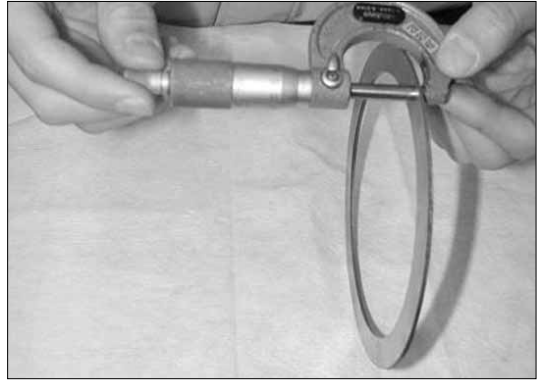

AX144

- ⑦ Insert adjustment shim for axial position of pinion.

Its value was computed previously ; also, fit outer races of pinion under head and shank bearings.



AX145

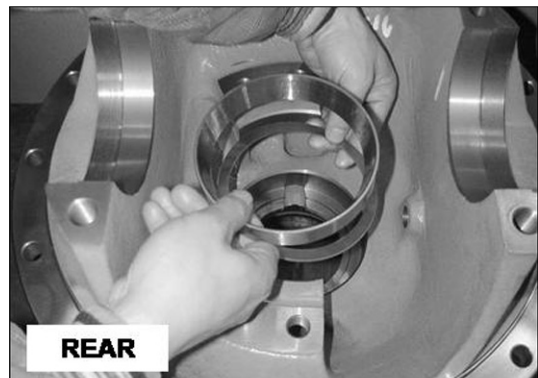

AX146

- ⑧ Fit in pinion shank inner race of under head bearing, heat or press-in part by installer.



AX049

⑨ Fit in inner race bearing by pressing.

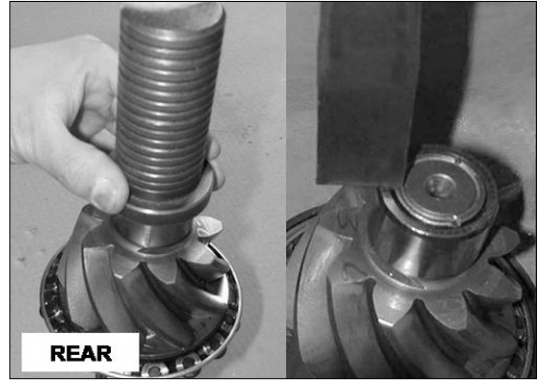

AX147

⑩ Fit in bearing by pressing.
Assemble the pin and washer.
(Rear differential only)



AX148

⑪ Assemble the pump and shims(3EA).
(Front differential only)
Assemble the spacer and shims(2EA).
(Rear differential only)

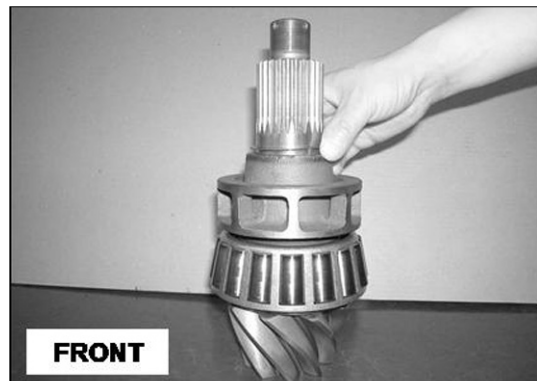

AX149



AX150

⑫ Turn the carrier upside down and assemble the bevel pinion assembly.

- ※ In order to contact between the bearing cone in pinion bevel and the cup bearing of carrier perfectly, support the bevel pinion by preferable tool.

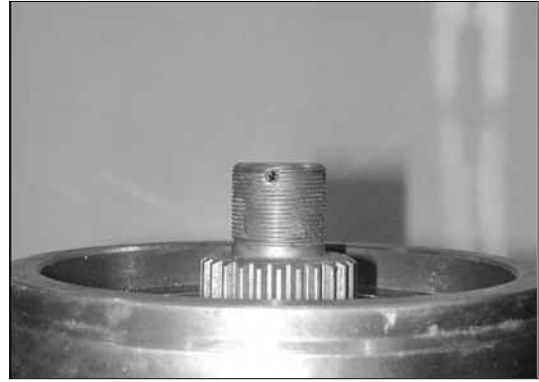

AX052

⑬ Fit in cone bearing by heating or pressing.



AX055

⑭ Assemble flange and holder in bevel pinion, and tighten pinion nut.

- ※ Don't assemble seal.
 - Tightening torque : 64~70kgf · m
(463~506lbf · ft)



AX056

⑮ Measure preload and confirm the follow value.

- ※ Bearing preload
 - Front axle : 0.2~0.4kgf · m
 - Rear axle : 0.2~0.4kgf · m
- ※ Before measuring preload, rotate two or three times. Disassemble and change adjustment shims and spacer(Rear axle only) to eliminate all end play up to reach a pre-load.



AX057

- ⑩ As bearing pre-load has been determined, remove drive flange and pinion nut holder.

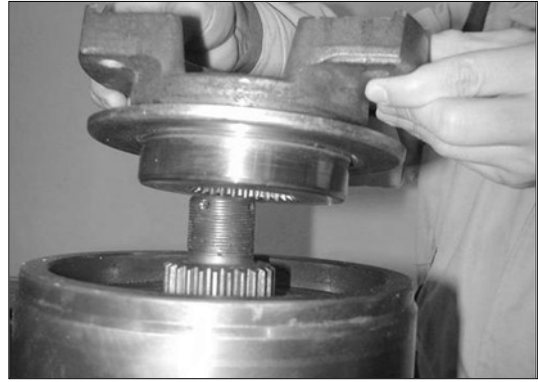

AX058

- ⑪ Assemble seal.

- ※ Cover the seal with retaining compound.
Cover the seal lip and the flange with oil.



AX059

- ⑫ Assemble the flange and the holder on the bevel pinion, and tighten the pinion nut and the split pin.

- Tightening torque : 64~70kgf · m
(463~506lbf · ft)

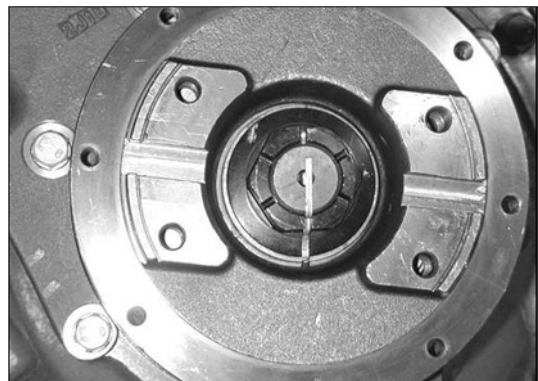

AX060

- ⑬ Install cross beam assembly to the location of bolts fixing bevel ring. And then assemble the bearing inner race before mounting differential to carrier.



REAR

AX151

- ⑳ Tighten the fixing bolt of cross beam assembly.

(Rear differential only)

- Tightening torque : 31.3~34.6kgf · m
(226~250lbf · ft)



AX152

- ㉑ Fit in the differential assembly on the carrier, and assemble adjusting nut temporarily.
- (Front differential only)

Assemble adjusting nut temporary.

(Rear differential only)

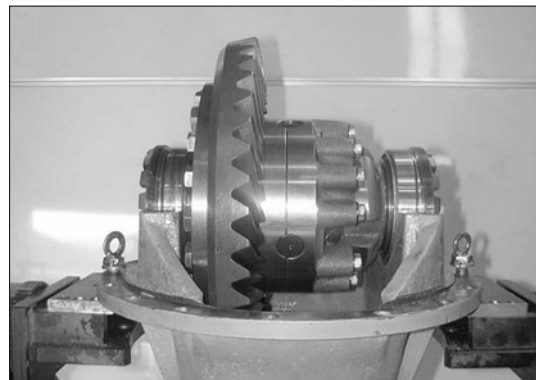

AX061

- ㉒ Install caps, care not to reverse position and lock screws fixing to differential support with belows.

※ Cap tightening torque

- Front axle : 63~69kgf · m(456~499lbf · ft)
- Rear axle : 31.3~34.6kgf · m(226~250lbf · ft)

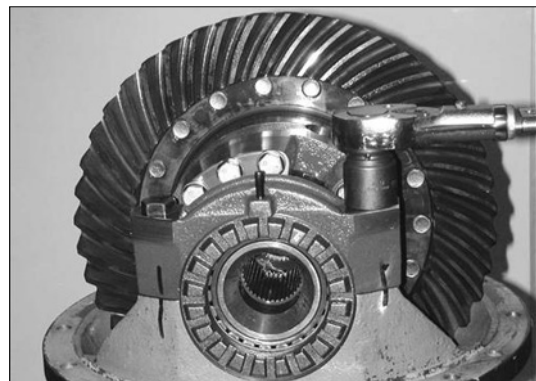

AX062

- ㉓ Position a dial gauge perpendicular than ring gear tooth and check, with pinion steady, backlash that has to be of 0.25~ 0.33mm (front) and 0.20~0.28mm(rear).

Otherwise rotate both ring nuts by displacing them of the same number of notches and nearing ring gear to pinion if backlash is excessive, by moving away on the contrary.

※ Bevel set back lash

- Front axle : 0.25~0.33mm
- Rear axle : 0.20~0.28mm

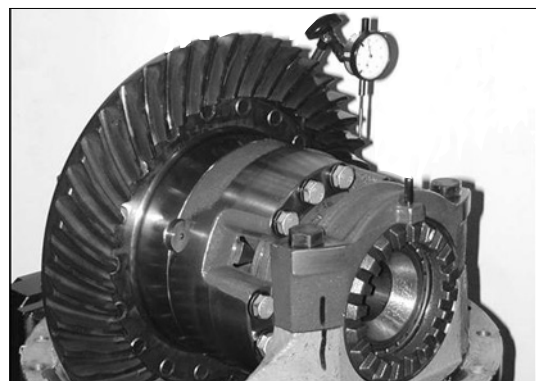

AX063

- ⑳ Brush red lead on some ring tooth, rotate to mesh pinion and ring gear repeatedly, so to make evident tooth contact. Proper and correct tooth contact marks are visible on a new bevel gear set as a result of an optimum contact approached on the tester, consequently, a proper axial position of pinion against ring gear will emphasise remarking of previous tester contact markings.

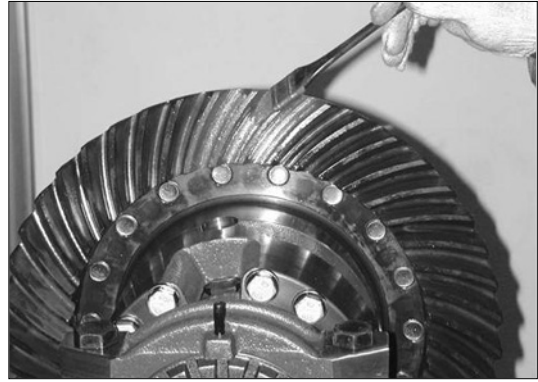

AX064

- ㉑ Fit spring pins locking threaded rings of differential unit.

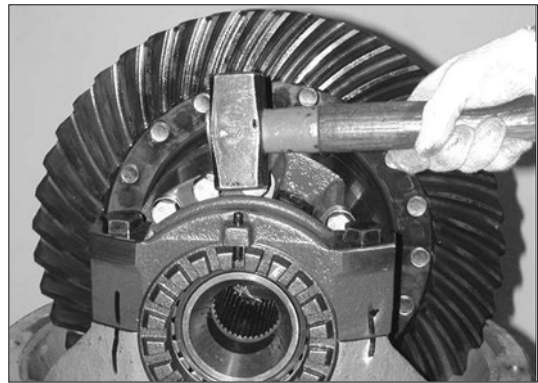

AX065

- ㉒ Apply flange sealant on the screw.
Tighten the screw until contacting the bevel gear and then loosen about 60° before tightening nut.

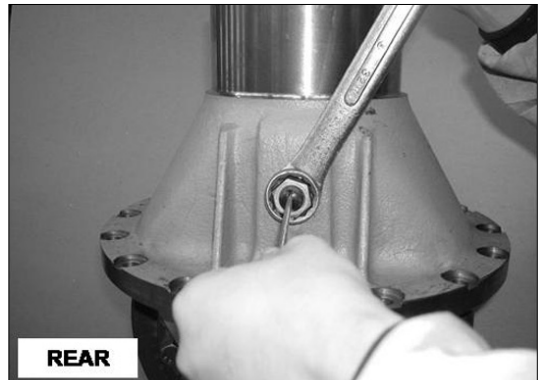

AX153

(4) HOUSING AND DIFFERENTIAL MOUNTING

- ① Perform two securing notches on pinion nut.
Clean with care contact surfaces, apply hard locking compound and then install the differential unit on axle case ; lock the connecting screws with a torque of 18.0~20.0Kgf · m(130~145lbf · ft).

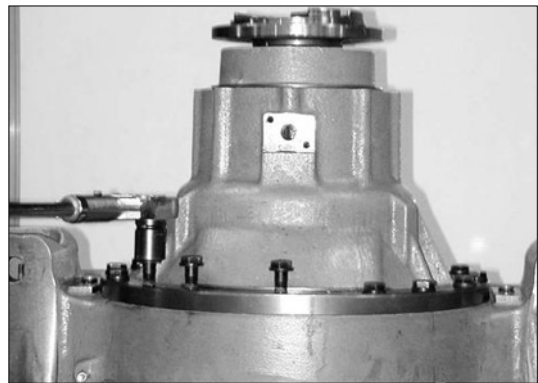

AX065

- ② Assemble O-ring on tube assembly port(3EA).
(Front axle only)

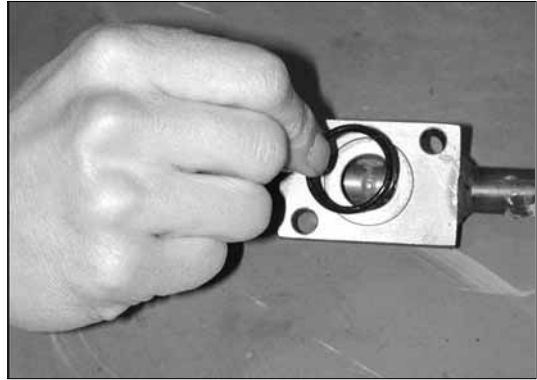

AX083

- ③ Position the tube assembly, fit screws and lock with a torque of 3.0~3.6Kgf · m(21.7~26.0lbf · ft).
(Front axle only)

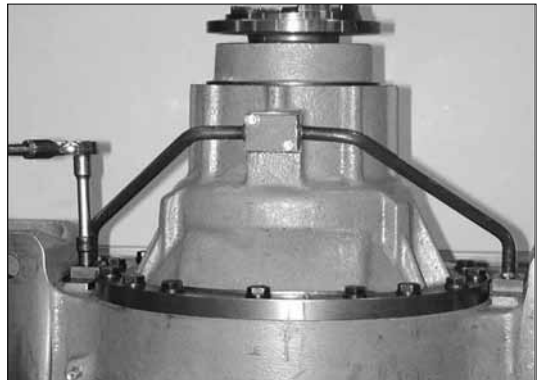

AX084

5) SUPER MAX TRAC

(1) DISASSEMBLY

- ① Mark the two half cases(LH/RH).



AX154

- ② Loosen the bolts of the case(RH) and remove the case(LH).



AX155

- ③ Remove the side gear and the thrust washer.



AX156

- ④ Remove spider with the four side gears and relevant bevel thrust washers.



AX157

- ⑤ Remove the planetary gear with relevant intermediate and shim discs and clutch discs, in half case on bevel gear side.



AX158

- ⑥ Loosen bevel gear fixing screws.



AX159

(2) ASSEMBLY

① Install gear-bevel on case(LH) by bolts.

※ Tightening torque

- Front axle : 45.6~50.4kgf · m(330~365lbf · ft)
- Rear axle : 31.3~34.6kgf · m(226~250lbf · ft)



AX160

② Insert side gear assembly and thrust washer in case(LH).

Assemble spider and side gear according to procedure.



AX079

③ Mount the cover, taking care to align the reference marked done before disassembling ; close the two half casings.

Screw in fixing screws and lock a torque of ;

- Front and rear axle : 11.4~12.6kgf · m
(82.5~91.1lbf · ft)



AX162

6) TOOLS

- ① Spring compression tool.



AX124

- ② Nut adjusting tool of reduction assembly.



AX125

4. ZF AXLE (Machine serial No. ; #0294~)

· FRONT AXLE

1) DISASSEMBLY OF OUTPUT AND BRAKE

(1) Fasten axle on assembly truck.

※ Special tool

Assembly truck 5870 350 000

Holding fixtures 5870 350 077

Clamps 5870 350 075

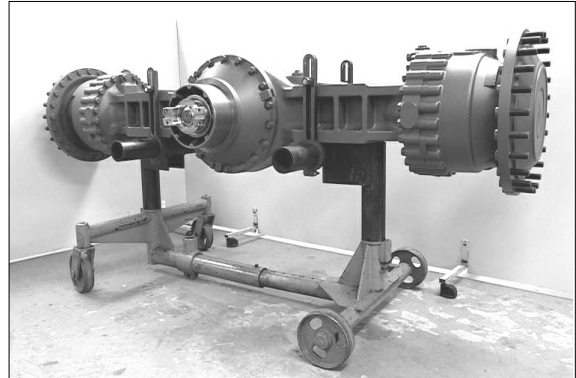

7577AAXF001

(2) Loosen screw plugs (3EA, see Figure 7577AAXF002 and 003) and drain oil from axle casing.

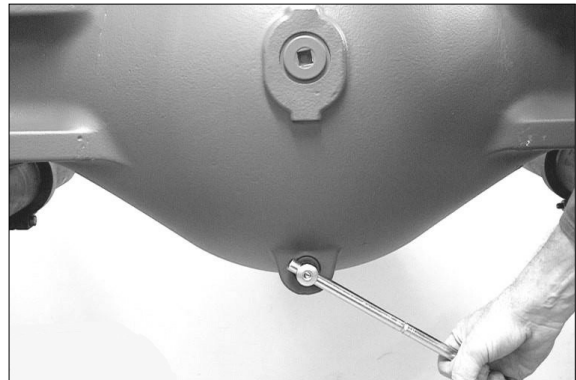

7577AAXF002

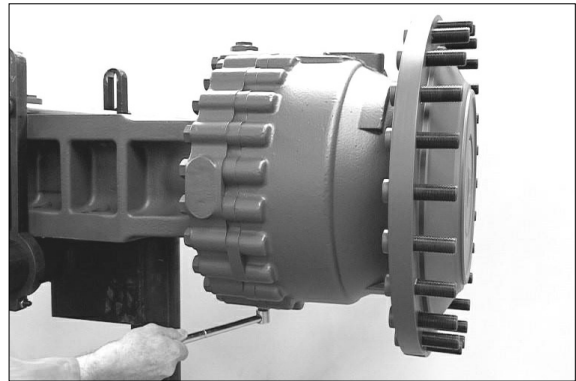

7577AAXF003

(3) Press off cover from the output shaft.

※ Special tool

Pry bar set 5870 345 065

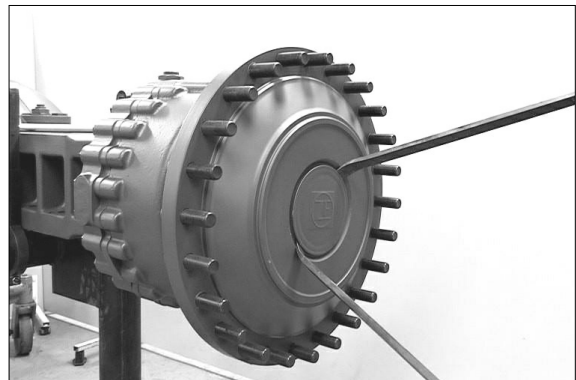

7577AAXF004

(4) Pull slotted pin by means of the striker out of the bore in the slotted nut.

※ Special tool

Striker

5870 650 001

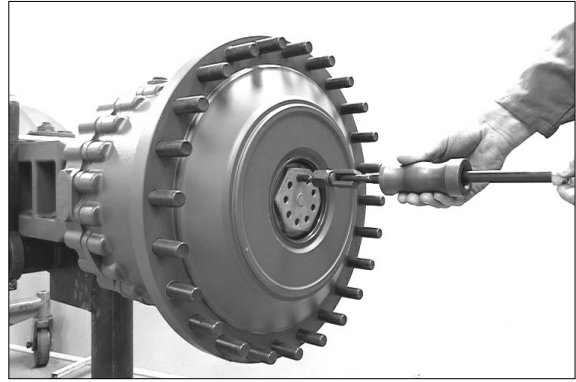

7577AAXF005

(5) Loosen slotted nut.

※ Special tool

Socket spanner

5870 656 078

Centering bracket

5870 912 028

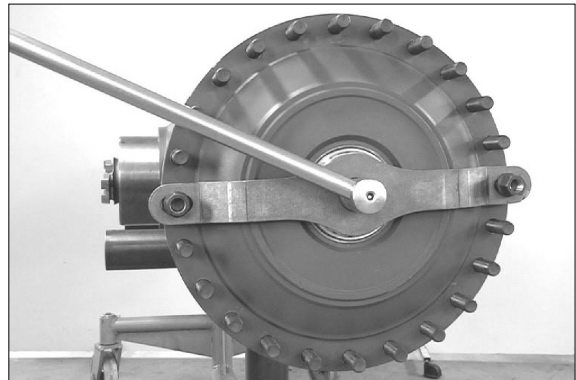

7577AAXF006

(6) Secure output by means of lifting tackle and loosen hexagon screws.

※ Special tool

Lifting bracket

5870 281 043

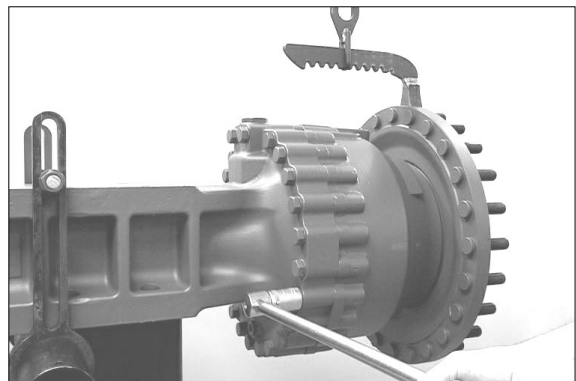

7577AAXF007

(7) Separate complete output from the axle casing.

※ Pay attention to released O-ring (see arrow).

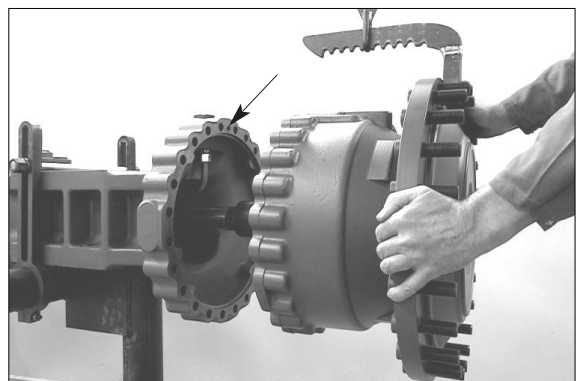

7577AAXF008

- (8) Pull stub shaft out of the sun gear shaft.
※ Pay attention to possibly released shim(s).

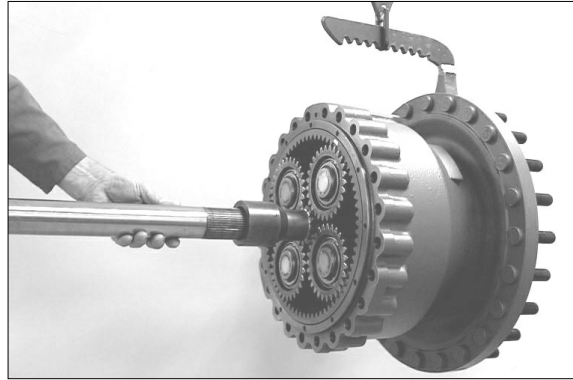

7577AAXF009

- (9) Remove shim(s) from the sun gear shaft.



7577AAXF010

- (10) Pull sun gear shaft out of the planet gears.



7577AAXF011

- (11) Lift planet carrier out of the brake housing.

- ※ Special tool
Internal extractor 5870 300 019

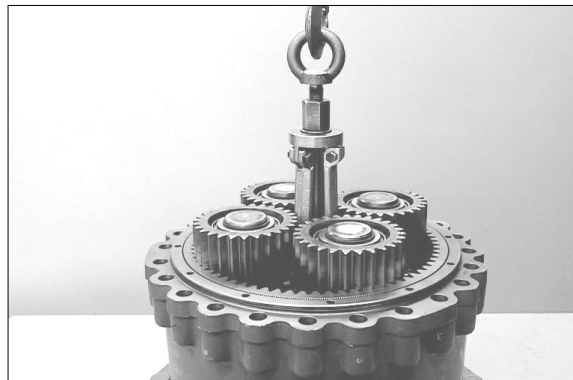

7577AAXF012

(12) Squeeze out the retaining ring.

- ※ Special tool
Set of external pliers 5870 900 015

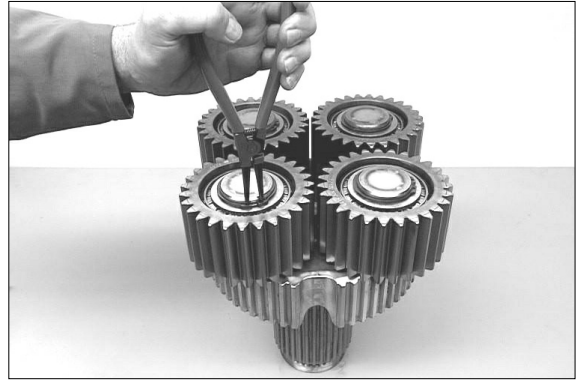

7577AAXF013

(13) Pull off the planet gear and remove the released bearing inner ring.

- ※ Special tool
Three-armed puller 5873 971 002



7577AAXF014

(14) Pull off the bearing inner ring.

- ※ Special tool
Gripping insert 5873 001 020
Basic set 5873 001 000

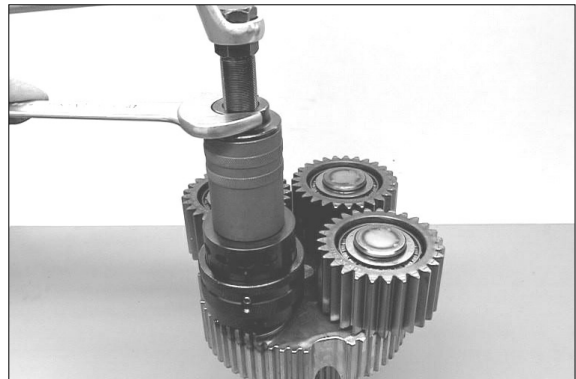

7577AAXF015

(15) Separate ring gear from the brake housing by means of two-armed puller.

- ※ Special tool
Two-armed puller 5870 970 007



7577AAXF016

(16) Remove O-rings (see arrows) from the annular grooves of the ring gear.

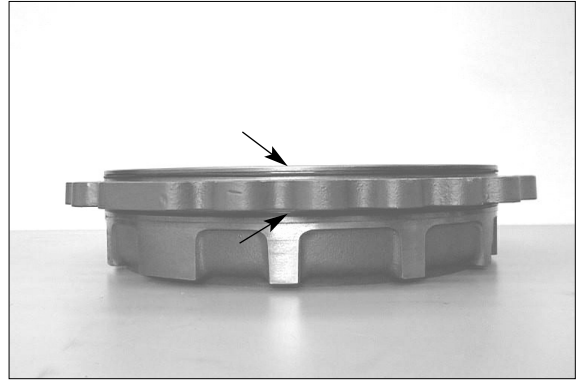

7577AAXF017

(17) Remove O-ring (see arrow) from the recess of the brake housing.



7577AAXF018

(18) Take the disc pack out of the brake housing.

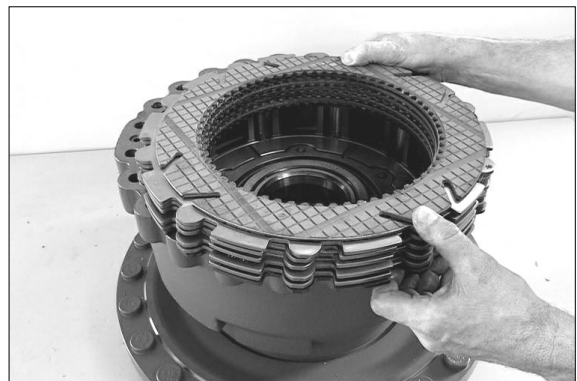

7577AAXF019

(19) Install slotted pins (6EA) in the support shim until they are flush-mounted.



7577AAXF020

(20) Squeeze out the circlip.

※ Special tool

Set of external pliers

5870 900 016

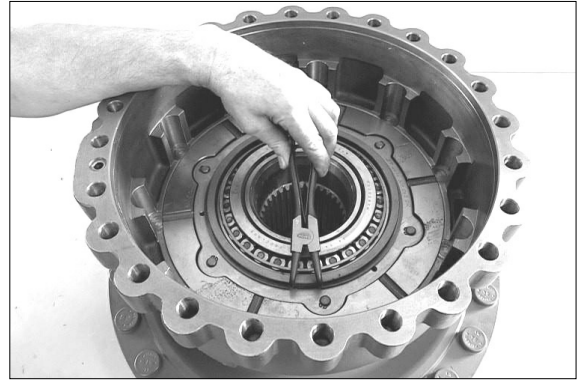

7577AAXF021

(21) Press piston out of the brake housing by means of compressed air.



7577AAXF022

(22) Press support shim out of the piston by means of the automatic piston adjusting.

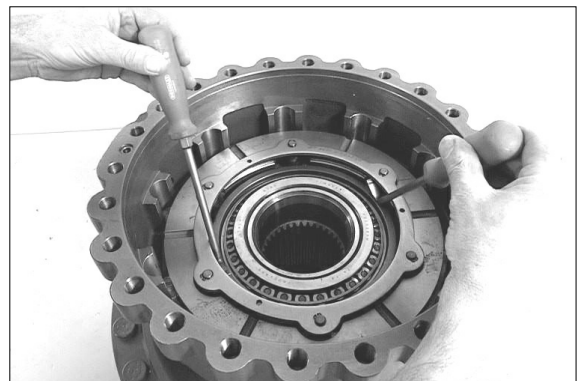

7577AAXF023

(23) Drive slotted pins (6EA) out of the support shim.

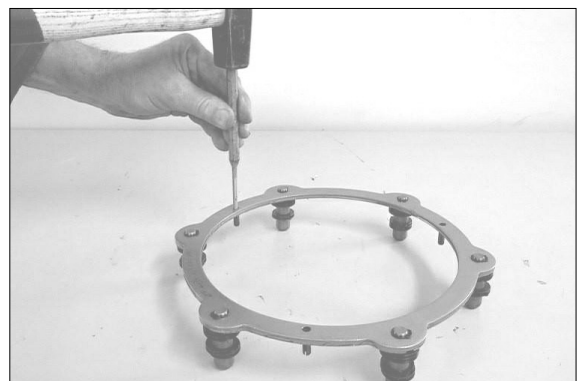

7577AAXF024

(24) Preload cup springs by means of a press and squeeze out the circlip.

※ Special tool

Assembly pliers 5870 900 051

Assembly fixture 5870 345 096

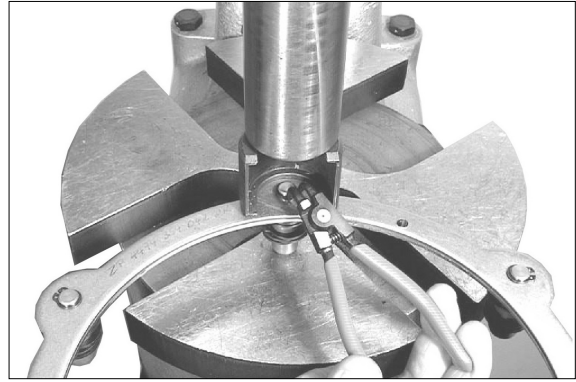

7577AAXF025

(25) Pull pin out of the support shim and remove released cup springs.



7577AAXF026

(26) Press gripping rings from the pin.

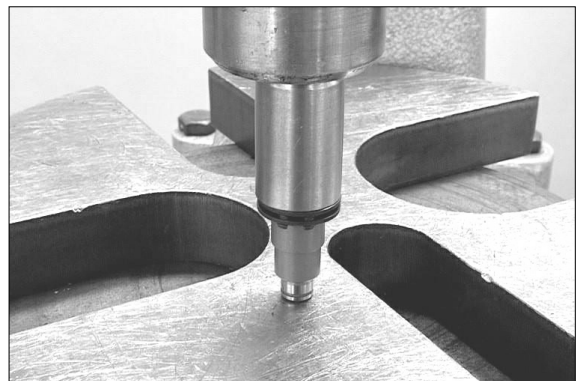

7577AAXF027

(27) Lift piston out of the brake housing.

※ Special tool

Adjusting device 5870 400 001



7577AAXF028

(28) Remove guide ring, support rings and U-rings from the annular grooves of the brake housing.

※ See below sketch for installation position of the single parts.

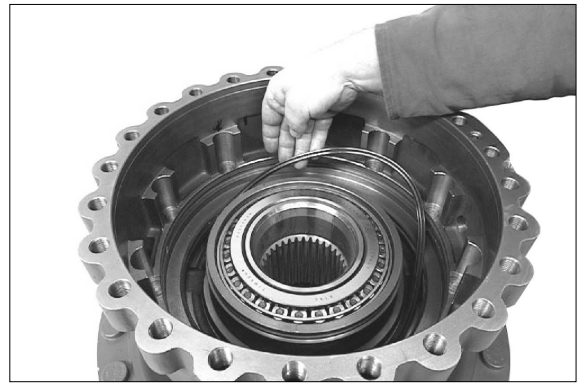

7577AAXF029

To the sketch :

- 1 Brake housing
- 2 Guide ring
- 3 Support ring
- 4 U-ring
- 5 U-ring
- 6 Support ring
- 7 Output shaft

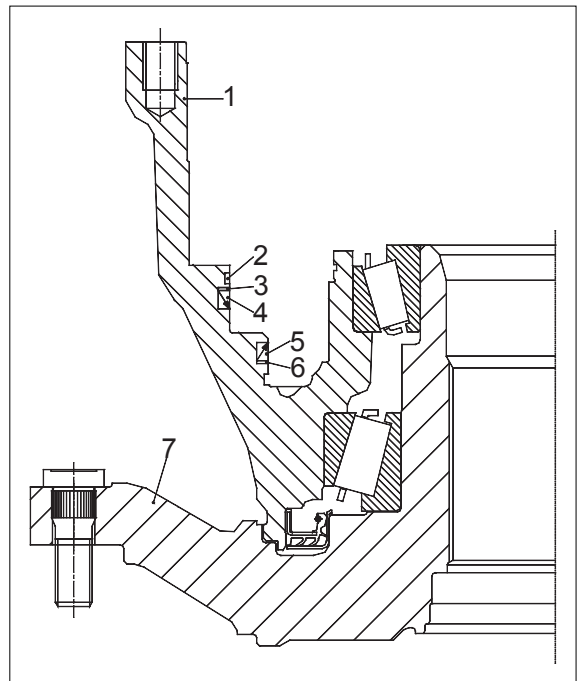

7577AAXF030

(29) Pull brake housing by means of two-armed puller from the output shaft and remove the released bearing inner ring.

※ Special tool

- | | |
|------------------|--------------|
| Two-armed puller | 5870 970 007 |
| Clamping bracket | 5870 654 034 |
| Press bush | 5870 506 140 |



7577AAXF031

(30) Lift brake housing with lifting tackle from the output shaft.

※ Special tool

Lifting chain 5870 281 047

Eye bolts 5870 204 071

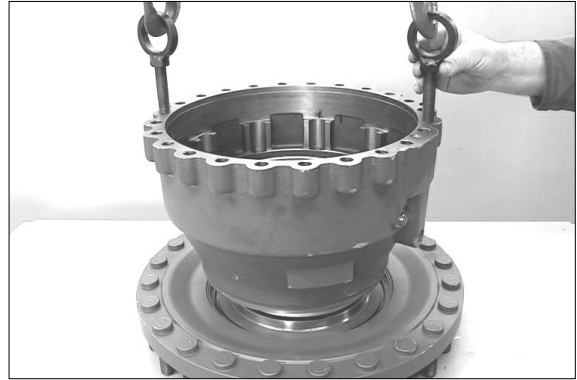

7577AAXF032

(31) If necessary drive both bearing outer rings out of the bearing bores in the brake housing.



7577AAXF033

(32) Press shaft seal out of the brake housing.

※ Special tool

Pry bar set 5870 345 065



7577AAXF034

(33) Pull bearing inner ring from the output shaft.

※ Special tool

Rapid grip 5873 014 013

Basic set 5873 004 001

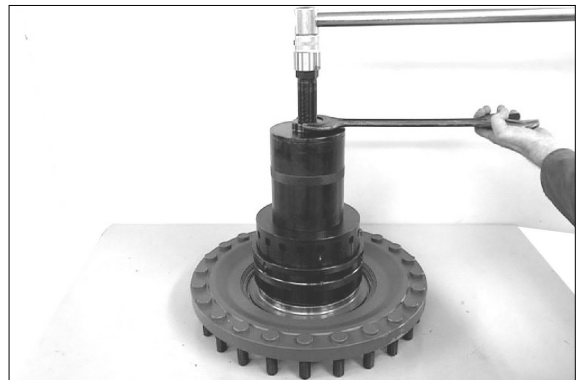

7577AAXF035

(34) Press off bearing sheet from the output shaft.

※ Special tool
Pry bar set

5870 345 065



7577AAXF036

2) REASSEMBLY OF OUTPUT AND BRAKE

(1) Insert wheel bolt into the output shaft until contact.

※ Special tool

Wheel bolt puller-basic set 5870 610 010

Insert (7/8"-14 UNF) 5870 610 011

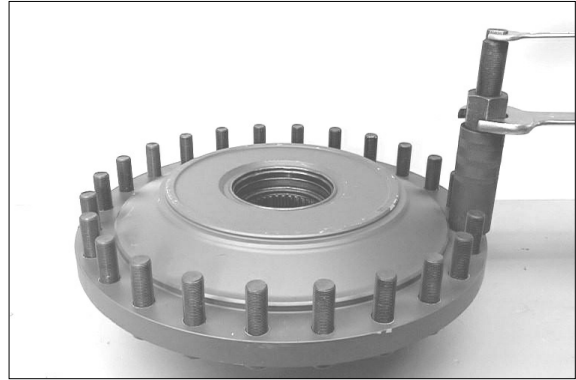

7577AAXF037

(2) Assemble bearing sheet (shaft seal).



7577AAXF038

(3) Press bearing sheet over the collar of the output shaft.

※ Special tool

Pressure ring 5870 506 141

※ The exact installation position of the bearing sheet will be obtained by using the specified pressure ring.

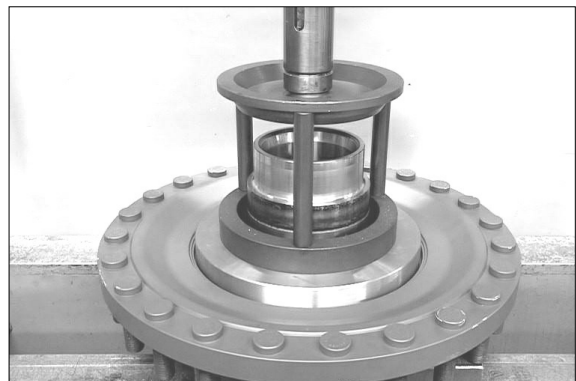

7577AAXF039

(4) Heat the roller bearing and install it until contact.

※ After cooling-down the bearing has to be installed subsequently.



7577AAXF040

- (5) Press both bearing outer rings into the brake housing until contact.

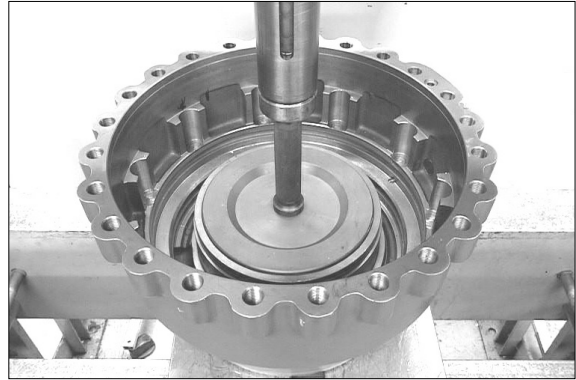

7577AAXF041

- (6) Install shaft seal with the sealing lip showing to the oil chamber (see below sketch).

- ※ Special tool
Driver 5870 051 052
- ※ The exact installation position of the shaft seal will be obtained by using the specified driver.

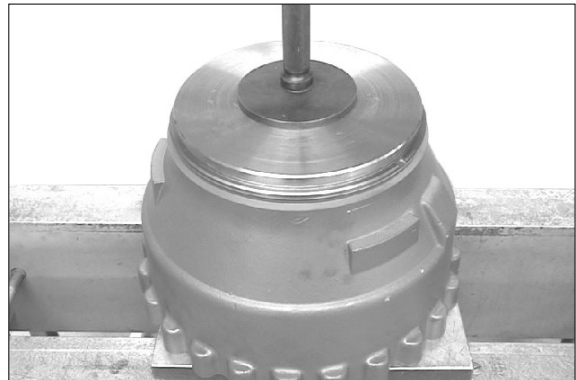

7577AAXF042

- ▲ **Just before the installation wet the outer diameter of the shaft seal with spirit.**

To the sketch :

- 1 Brake housing
- 2 Shaft seal
- * Grease filling

- ※ Fill the space between sealing and dust lips with grease.

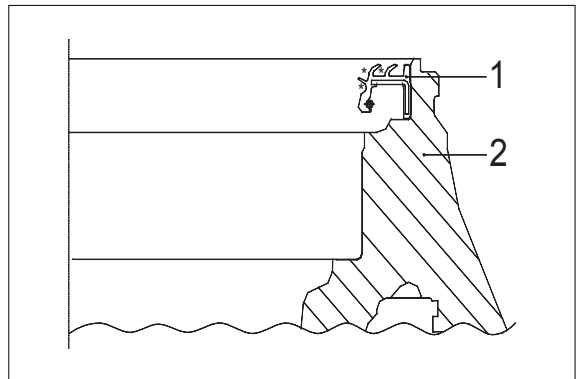

7577AAXF043

- (7) Install the preassembled brake housing by means of the lifting tackle over the output shaft until contact.

- ※ Special tool
Lifting chain 5870 281 047
Eye bolts 5870 204 071

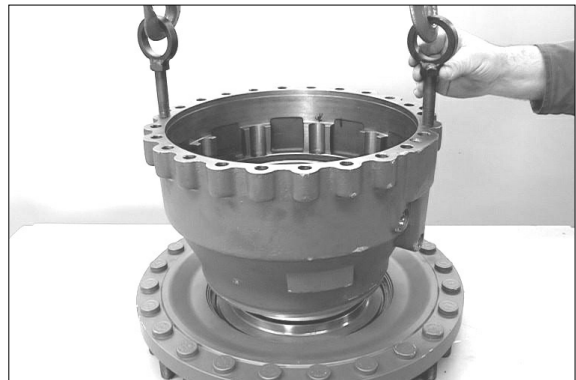

7577AAXF044

(8) Heat the roller bearing and install it until contact.

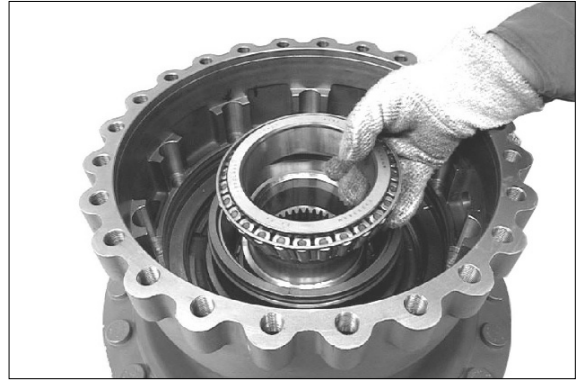

7577AAXF045

(9) Insert support and U-rings into the annular grooves of the brake housing.

※ Pay attention to the installation position, see below sketch.

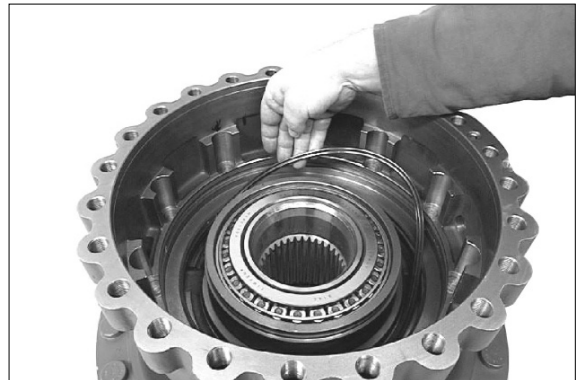

7577AAXF046

To the sketch :

- 1 Brake housing
- 2 Guide ring
- 3 Support ring
- 4 U-ring
- 5 U-ring
- 6 Support ring
- 7 Output shaft

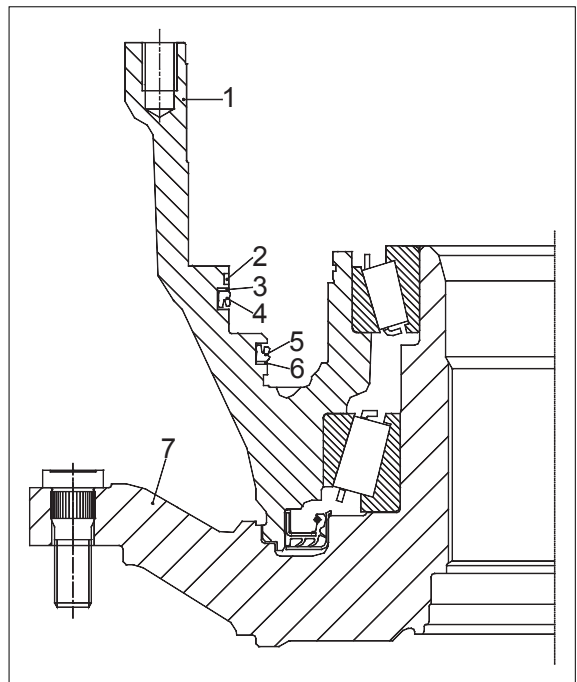

7577AAXF047

(10) Clean annular groove of the brake housing with spirit.

Then insert the guide ring into the annular groove (also see sketch page 3-192) and fix it with Loctite (Type No. 415) at its extremities.

※ Guide ring must have contact on the whole circumference.

▲ Upon installation the orifice of the guide ring must show upwards (12 o'clock).

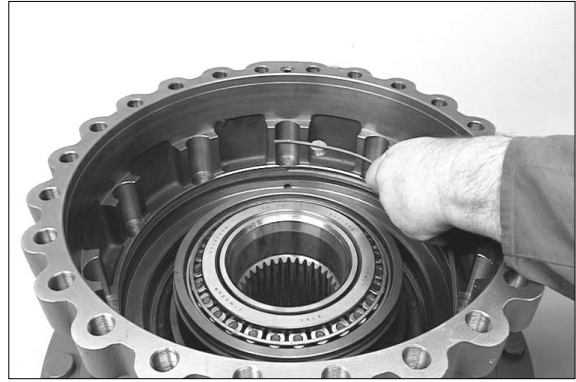

7577AAXF048

(11) Insert piston into the brake housing and install it cautiously until contact.

※ Apply sufficiently oil on the sliding surface of the piston or support rings, U-rings and guide ring (use W-10 oils).

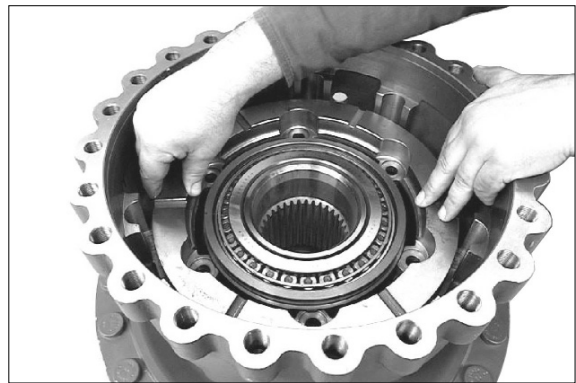

7577AAXF049

(12) Insert pins into the assembly fixture until contact.

※ Special tool
Assembly fixture 5870 345 096

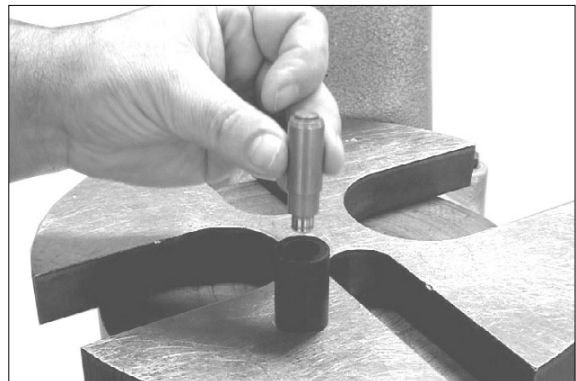

7577AAXF050

(13) Press gripping rings (4EA, see arrows) onto the pins until contact on the assembly fixture.

※ The exact installation dimension (see sketch page 3-194) of the gripping rings is obtained when using the specified assembly fixture.

▲ Observe the installation position, install gripping rings with the orifices offset by 180° to each other.

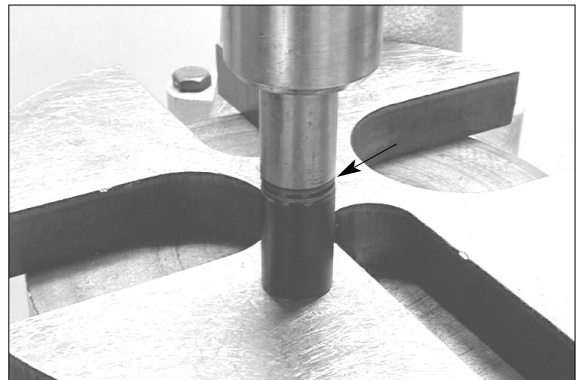

7577AAXF051

(14) Install cup springs (7 pieces each/pin).

- ※ Pay attention to the installation position of the cup springs, see below sketch.



7577AAXF052

To the sketch :

- 1 Pin
- 2 Gripping rings
- 3 Cup springs
- 4 Support shim
- 5 Circlip
- X Installation dimension gripping rings
 $10.5^{+0.3}$ mm

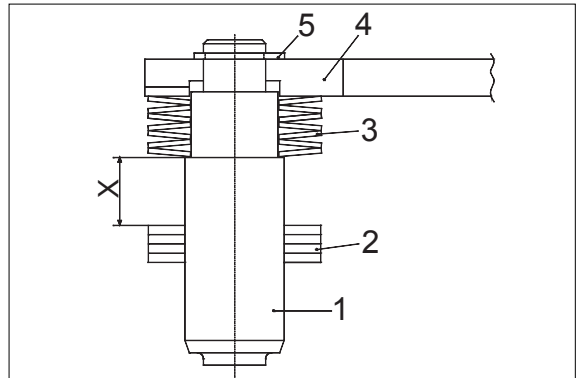

7577AAXF053

(15) Insert preassembled pins into the support shim and fix it by means of the circlip.

- ※ Special tool
Assembly pliers 5870 900 051
- ※ Pay attention to clearance of the cup springs.

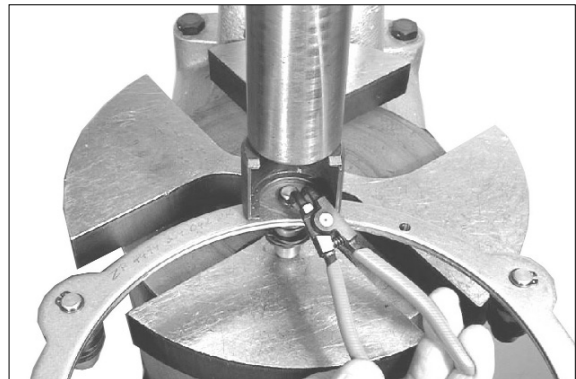

7577AAXF054

(16) Insert preassembled support shim into the piston.

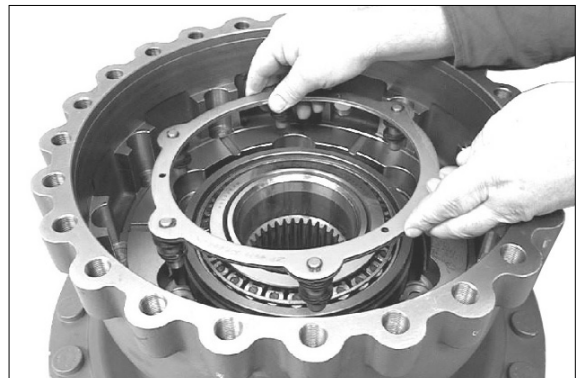

7577AAXF055

(17) Fix support shim by means of the circlip.

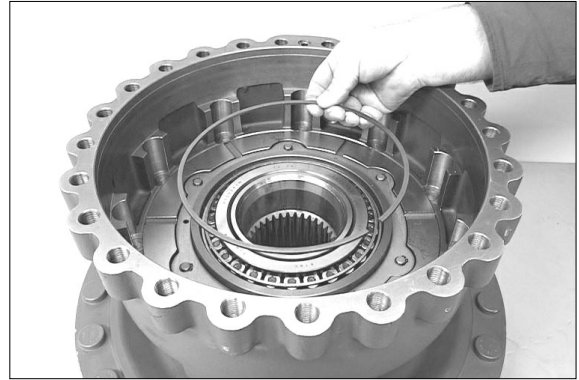

7577AAXF056

(18) Drive slotted pins (6EA) into the bores of the support shim to lock the circlip.

※ Special tool

Drive mandrel 5870 705 011

※ Pay attention to the installation position, see below sketch.



7577AAXF057

To the sketch :

1 Brake housing

2 Circlip

3 Slotted pin

4 Support shim

5 Piston

X Installation dimension $4.0_{-0,5}$ mm

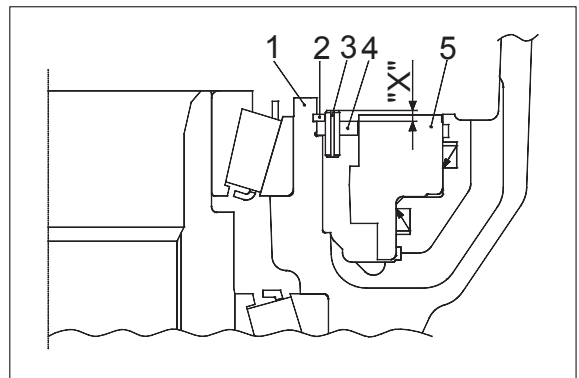

7577AAXF058

(19) Drive stop bolt into the planet carrier until contact.

Then wet spline (see arrow).



7577AAXF059

(20) Insert planet carrier into the spline of the output shaft until contact.

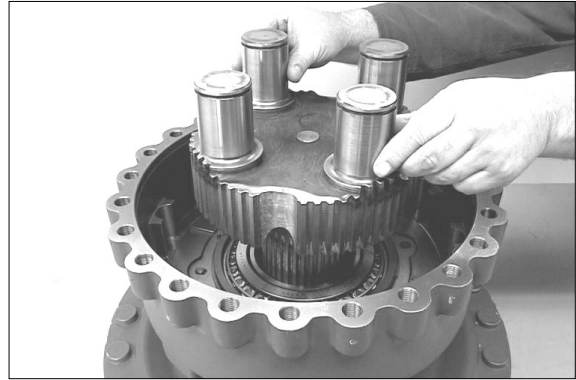

7577AAXF060

(21) Install outer-and inner clutch discs alternately starting with an outer clutch disc.

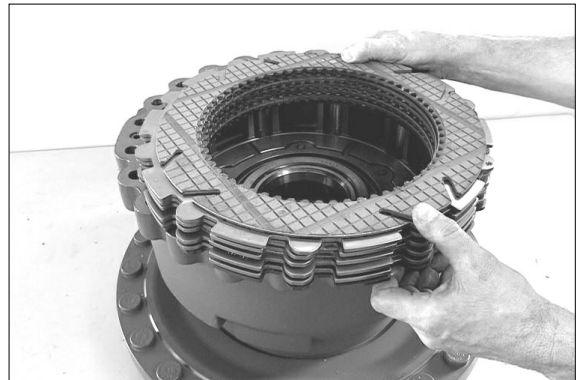

7577AAXF061

(22) Insert O-ring (see arrow) into the recess of the brake housing.

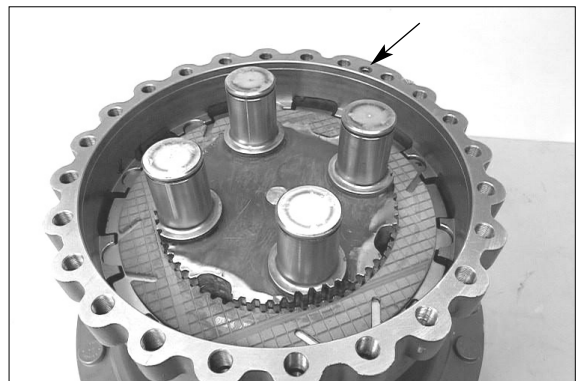

7577AAXF062

(23) Grease both O-rings (see arrows) and insert them into the annular grooves of the ring gear.

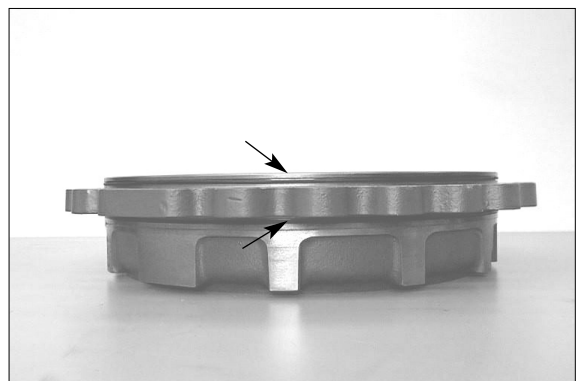

7577AAXF017

(24) Install two adjusting screws and insert ring gear into the brake housing until contact.

- ※ Special tool
Adjusting screws 5870 204 029
- ※ Pay attention to radial location.

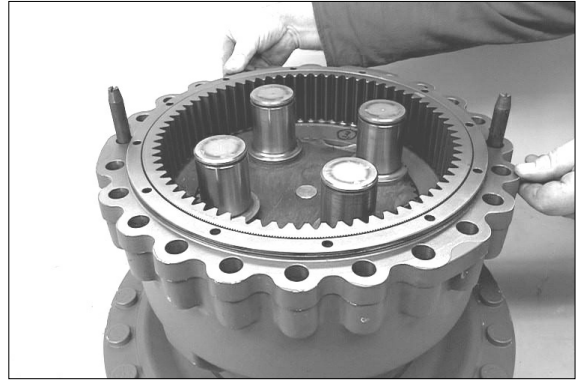

7577AAXF063

(25) Heat bearing inner rings and install them until contact with the big radius showing to the planet carrier (downwards).

- ※ Subsequently install bearing inner rings after cooling down.

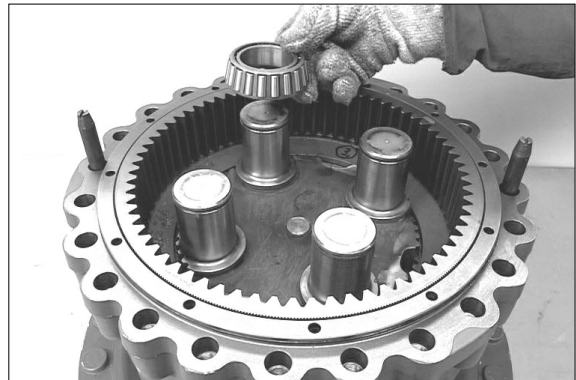

7577AAXF064

(26) Put planet gears onto the bearing inner rings.

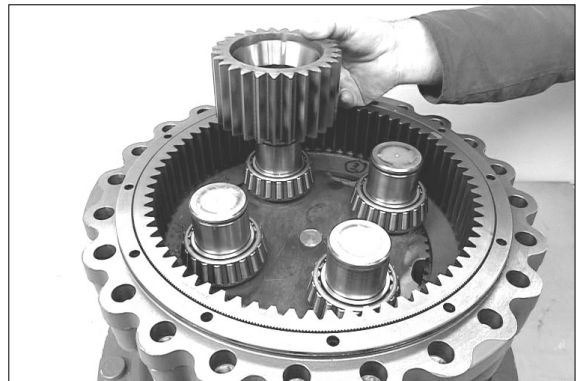

7577AAXF065

(27) Heat bearing inner rings and install them on the planet gears until contact.

- ※ Subsequently install bearing inner rings after cooling down.



7577AAXF066

(28) Fasten plant gears by means of retaining rings.

- ※ Special tool
- Set of external pliers 5870 900 015

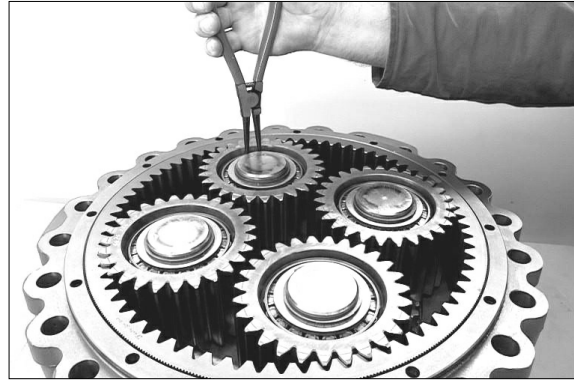

7577AAXF067

Adjust end play of sun gear shaft 0.5 ~ 2.0mm

(29) Fasten ring gear by means of cap screws until contact.

Then determine dimension I, from the mounting face of the ring gear up to the face of the stop bolt.

Dimension I e.g 46.20 mm

- ※ Special tool
- Digital depth gauge 5870 200 072
- Gauge blocks 5870 200 066
- Straightedge 5870 200 022

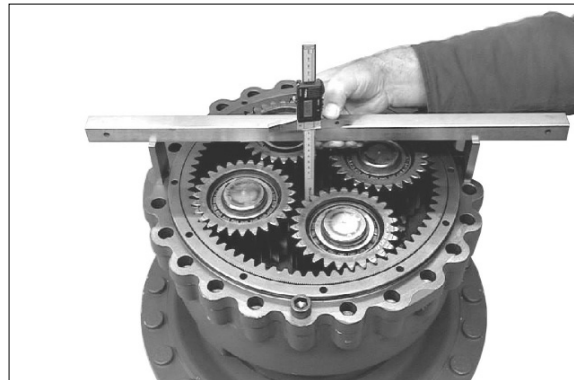

7577AAXF068

(30) Insert stub shaft into spline of the axle bevel gear until contact.

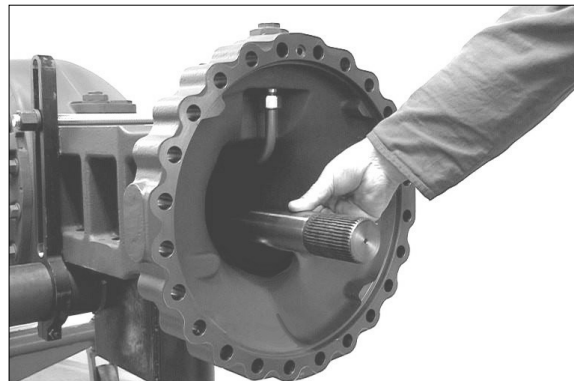

7577AAXF069

(31) Assemble sun gear shaft until contact.

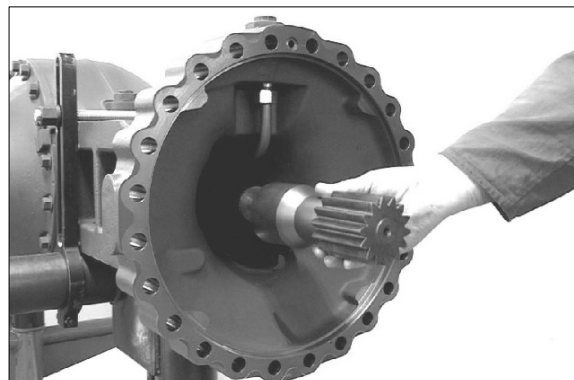

7577AAXF070

(32) Determine Dimension II from the face of the sun gear shaft up to the mounting face of the axle casing.

Dimension II e.g. 43.00mm

※ Special tool

Digital depth gauge 5870 200 072

Gauge blocks 5870 200 066

Straightedge 5870 200 022

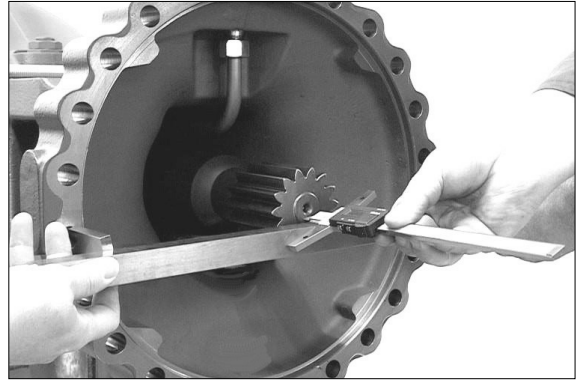

7577AAXF071

EXAMPLE A :

Dimension I 46.20mm

Dimension II - 43.00mm

Difference 3.20mm

required end play e.g. - 1.00mm

Difference = shim e.g. s = 2.20mm

(33) Insert sun gear shaft into the planet carrier.



7577AAXF072

(34) Fix determined shim(s), e.g. s = 2.20mm, into the sun gear shaft by means of grease.



7577AAXF073

(35) Fix O-ring(see arrow) into the recess of the axle casing by means of grease and install the preassembled output to the axle casing until contact by means of lifting tackle.

※ Special tool
Lifting bracket 5870 281 043

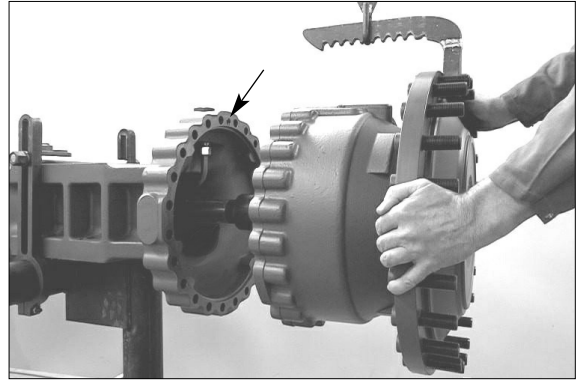

7577AAXF074

(36) Fasten output by means of hexagon screws and washers.

· Tightening torque (M18/10.9) :
39.8 kgf · m(288lbf · ft)

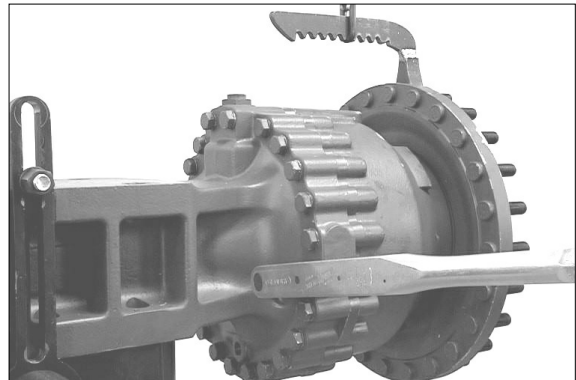

7577AAXF075

(37) Unscrew slotted nut by hand and then fasten it.

· Tightening torque : $153^{+20.4}$ kgf · m
(1107^{+148} lbf · ft)

※ Special tool
Socket spanner 5870 656 078
Centering bracket 5870 912 028



7577AAXF076

(38) Secure slotted nut by means of slotted pin.

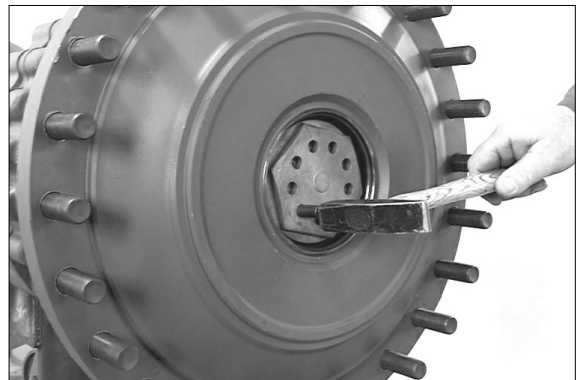

7577AAXF077

(39) Assemble O-ring (see arrow) to the cover.



7577AAXF078

(40) Insert cover into the output shaft until contact.

※ Special tool

Hammer (Plastic \varnothing 60) 5870 280 004



7577AAXF079

Leakage test of the brake hydraulics

※ Prior to start the test, ventilate the brake hydraulics completely.

- 1) Open the bleeder.
- 2) Slowly actuate the HP-pump until oil flows out of the bleeder.
- 3) Close the bleeder again.
- 4) Slowly pressurize the HP-pump with $p > 10$ bar and hold the pressure for some seconds.

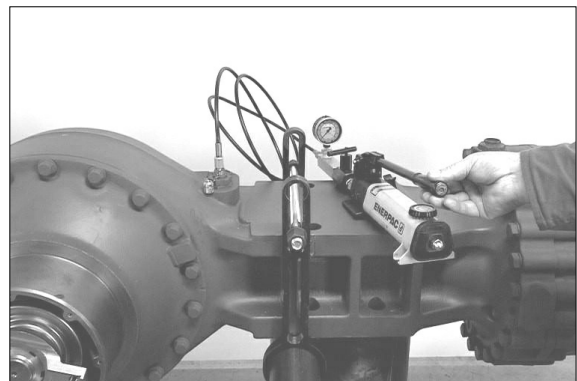

7577AAXF080

※ The brake piston extends and the cylinder chamber fills up with oil. The air accumulates in the upper section of the cylinder chamber.

- 5) Loosen the shut-off valve on the HP-pump.

※ The reversing piston presses the air from the upper section of the cylinder into the brake line.

- 6) Open the bleeder again.

- 7) Slowly actuate the HP-pump until oil flows out of the bleeder.

※ Repeat procedure - Item 3)~7) until at 7) from the beginning of the actuation no more air exits from bleeder.

※ Then pressurize the brake temporarily (5EA) with $p = 100$ bar max..

High-pressure test :

Increase test pressure up to $p = 100_{-10}$ bar and close connection to HP-pump by means of shut-off valve.

During a 5 min. testing time a pressure drop of max. 2% (2 bar) is allowed.

▲ If the maximum pressure of 100 bar is exceeded, there will be an excessive piston adjustment and a repeated disassembly of the brake or the adjusting is required to reset the gripping rings to the adjusting dimension.

Low-pressure test :

Reduce test pressure to $p = 5$ bar and close the shut-off valve again.

During a 5 min. testing time a pressure drop is not allowed.

※ Special tool

HP-Pump 5870 287 007

Mini-measuring hub 5870 950 115

(9/16"- 18UNF)

※ Prior to putting the axle into operation, fill in the oil acc. to the lubrication instructions.

3) DISASSEMBLY OF DIFFERENTIAL CARRIER AND BRAKE TUBES

(1) Disassembly of differential carrier

① Fasten axle on assembly truck.

※ Special tool

Assembly truck 5870 350 000

Holding fixtures 5870 350 077

Clamps 5870 350 075

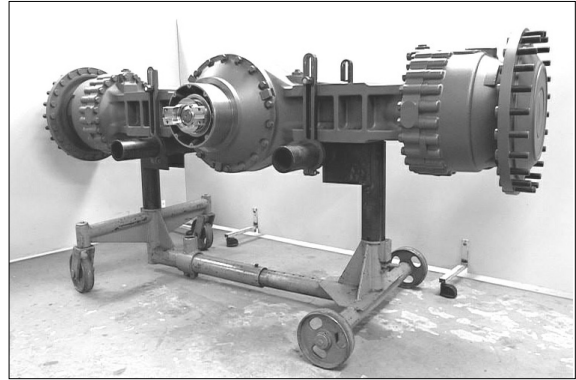

② Loosen screw plugs (3EA, see Figure 7577AAXF002 and 003) and drain oil from axle casing.

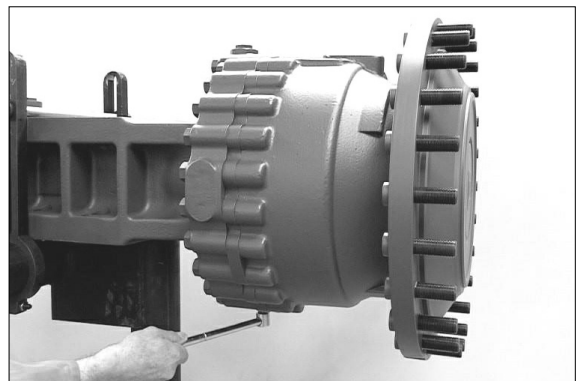
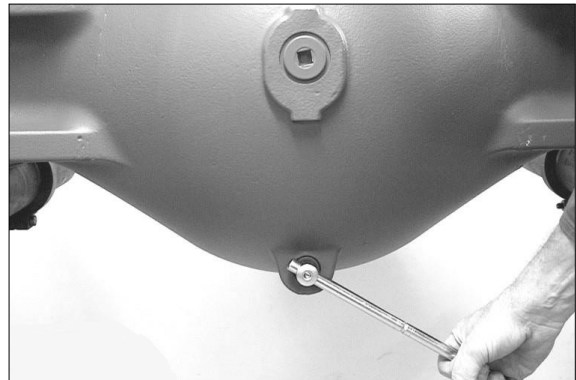

③ Secure output by means of lifting tackle and loosen hexagon screws.

※ Special tool

Lifting bracket 5870 281 043

※ Make step (Fig. 7577AAXF007~9) on both output sides.

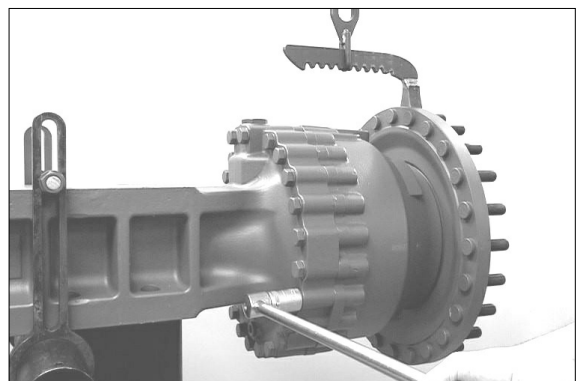

④ Separate complete output from the axle casing.

※ Pay attention to released O-ring(see arrow).

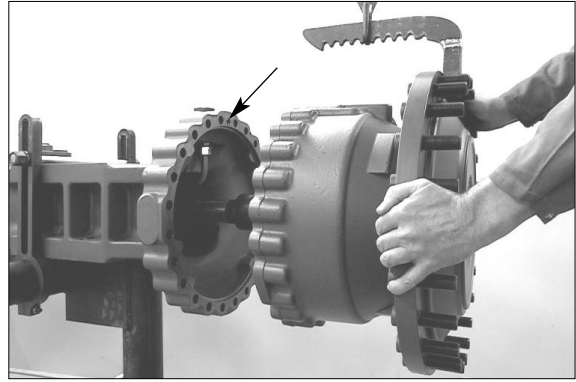

7577AAXF008

⑤ Pull stub shaft out of the sun gear shaft.

※ Pay attention to released shim(s).

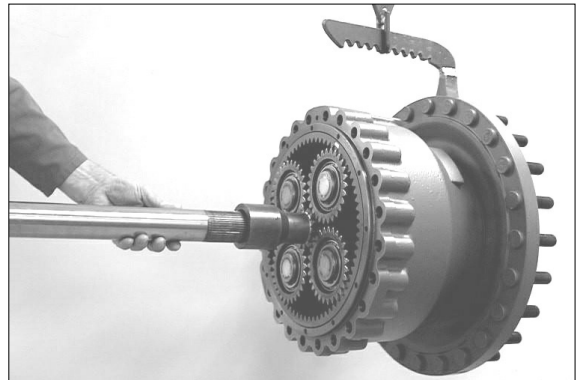

7577AAXF009

⑥ Loosen hexagon screws.

※ Mark location of differential carrier to the axle casing (see arrows).



7577AAXF081

⑦ Lift differential carrier by means of lifting tackle out of the axle casing.

※ Special tool
Lifting tackle

5870 281 044

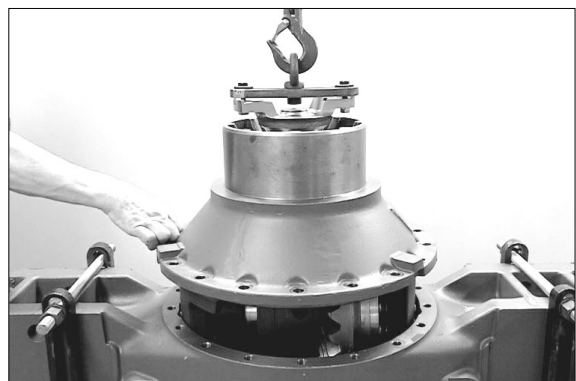

7577AAXF082

⑧ Fasten differential carrier to assembly truck.

- ※ Special tool
- Assembly truck 5870 350 000
- Holding fixture 5870 350 034

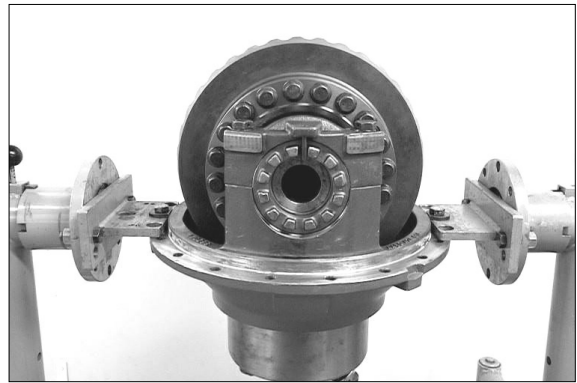

7577AAXF083

⑨ Drive out slotted pins.

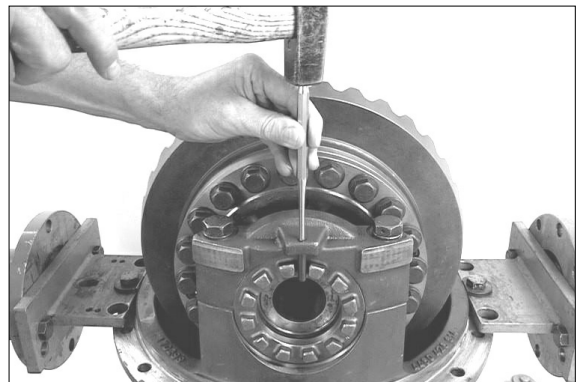

7577AAXF084

⑩ Loosen and remove both adjusting nuts.

- ※ Special tool
- Socket spanner 5870 656 079

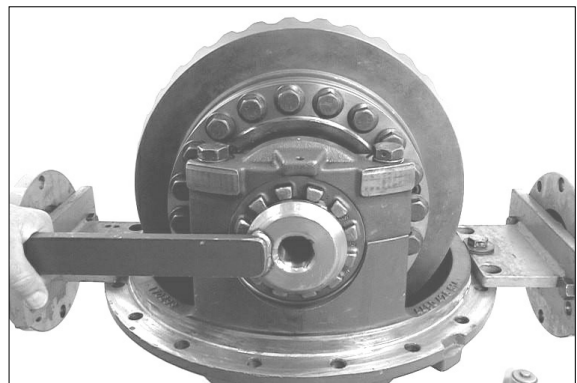

7577AAXF085

⑪ Heat axle drive housing by means of hot-air blower.

- ※ Special tool
- Hot-air blower 230 V 5870 221 500
- Hot-air blower 115 V 5870 221 501
- ※ Hexagon screws are installed with Loctite (Type No. 262).



7577AAXF086

⑫ Loosen hexagon screws and take off bearing bracket.

▲ Loosen hexagon screws by hand only.

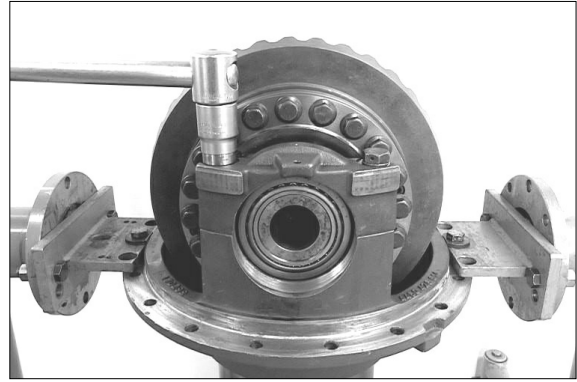

7577AAXF087

⑬ Remove both bearing outer rings.

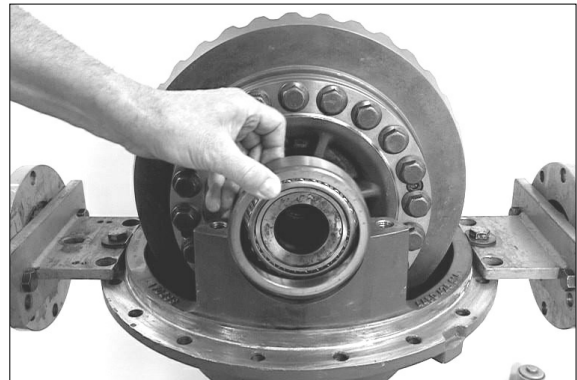

7577AAXF088

⑭ Lift differential out of the housing by means of lifting tackle.

※ Special tool
Lifting tackle 5870 281 013

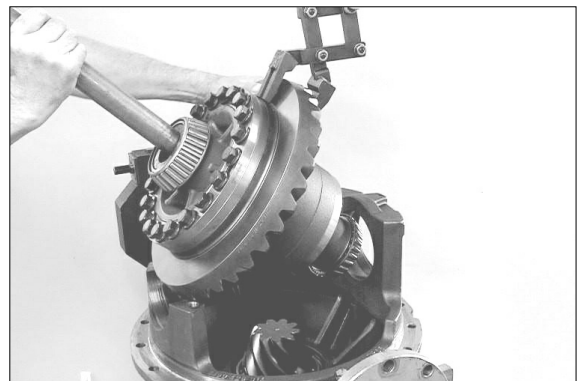

7577AAXF089

Disassembly of limited slip differential

⑮ Pull bearing inner ring from the differential housing.

※ Special tool
Gripping insert 5873 002 023
Basic set 5873 002 001

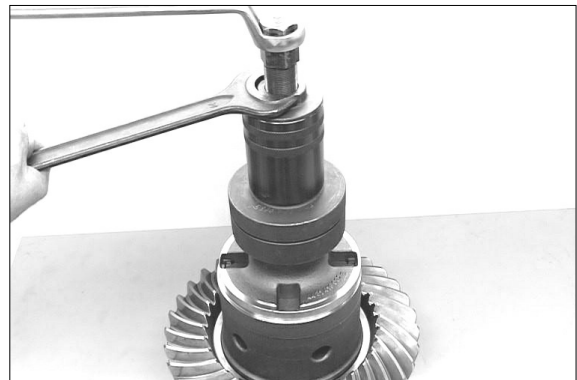

7577AAXF090

⑩ Pull bearing inner ring from the housing cover.

※ Special tool

Rapid grip

5873 012 018

Basic set

5873 002 001

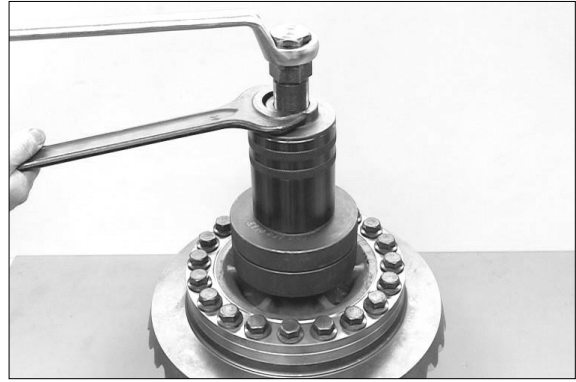

7577AAXF091

⑪ Fasten differential by means of press and loosen locking screws.

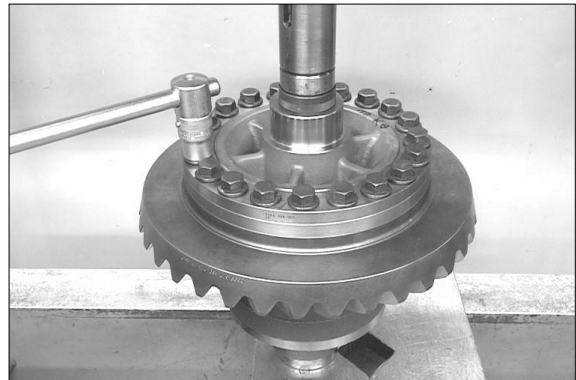

7577AAXF092

⑫ Loosen cap screws and remove released housing cover.

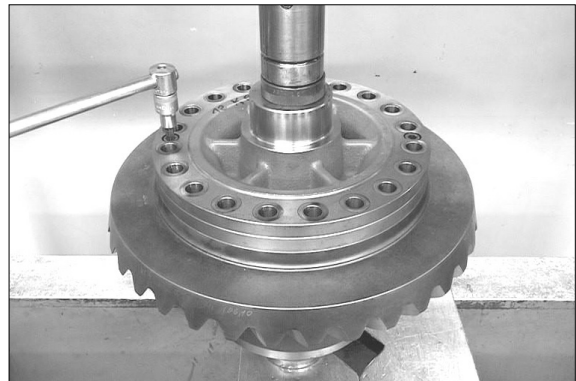

7707AAXR001

⑬ Remove all single parts from the differential housing.

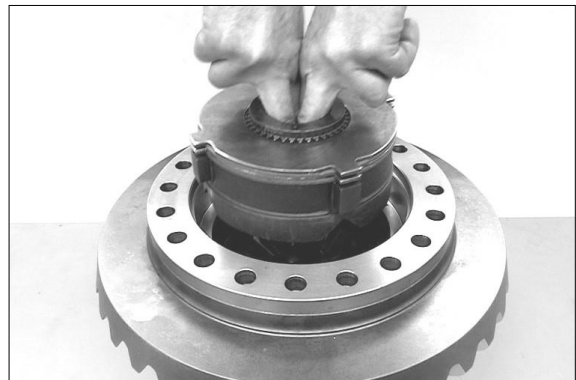

7577AAXF093

- ⑳ Press off crown wheel from the differential housing.

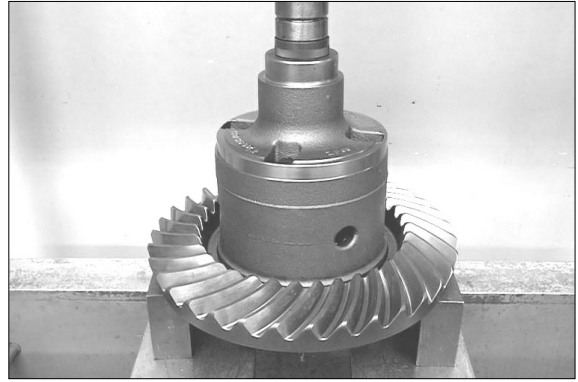

7577AAXF094

Disassembly of drive pinion

- ㉑ Heat slotted nut by means of hot-air blower.

※ Special tool

Hot-air blower 230 V 5870 221 500

Hot-air blower 115 V 5870 221 501

※ Slotted nut is locked with Loctite (Type No. 262).

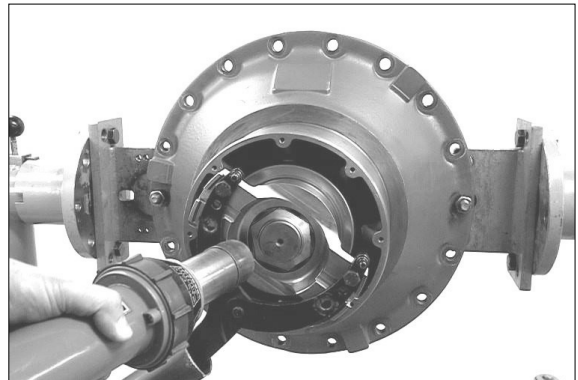

7577AAXF095

- ㉒ Loosen slotted nut and remove the washer behind it.

※ Special tool

Slotted nut wrench 5870 401 139

Fixture 5870 240 002

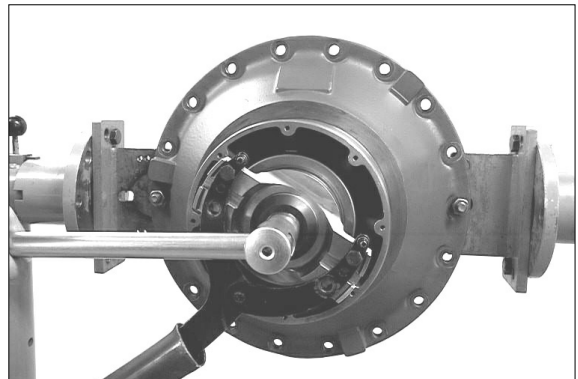

7577AAXF096

- ㉓ Pull input flange from the drive pinion.

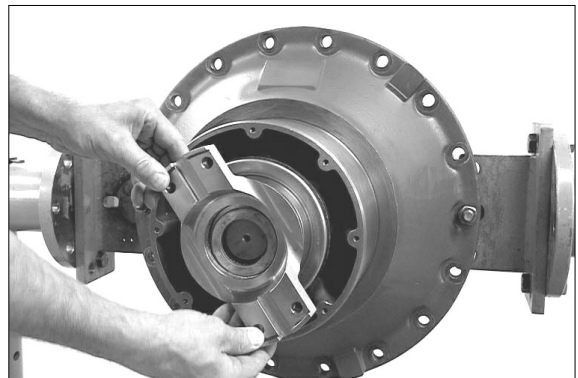

7577AAXF097

- ②④ Press shaft seal out of the axle drive housing.

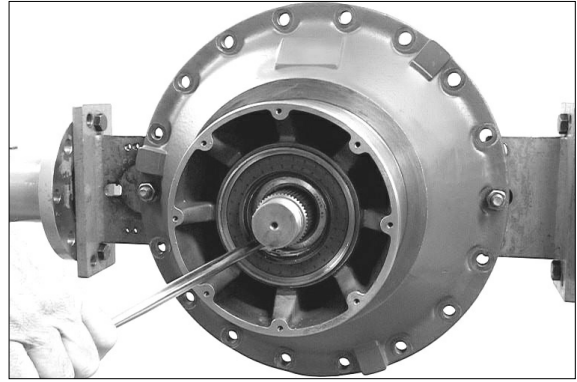

7577AAXF098

- ②⑤ Press drive pinion out of the axle drive housing by means of two-armed puller and remove the released bearing inner ring.

- ※ Special tool
Two-armed puller 5870 970 007

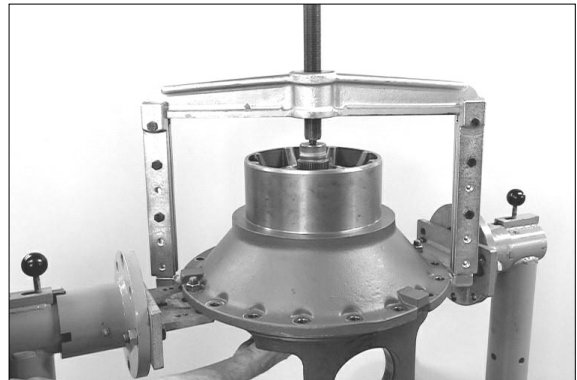

7577AAXF099

- ②⑥ Take off spacer ring and pull bearing inner ring from the drive pinion.

- ※ Special tool
Gripping insert 5873 002 032
Basic set 5873 002 001

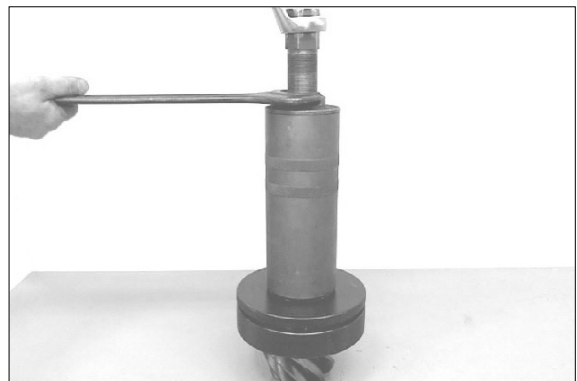

7577AAXF100

- ②⑦ If necessary drive out both bearing outer rings from the axle drive housing.

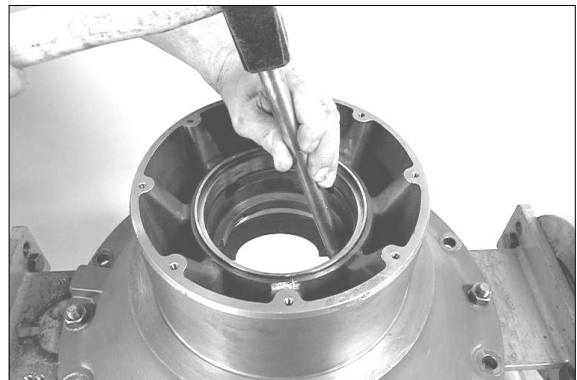

7577AAXF101

(2) Disassembly of brake tubes

- ① Remove screw plug with vent valve from the axle casing.

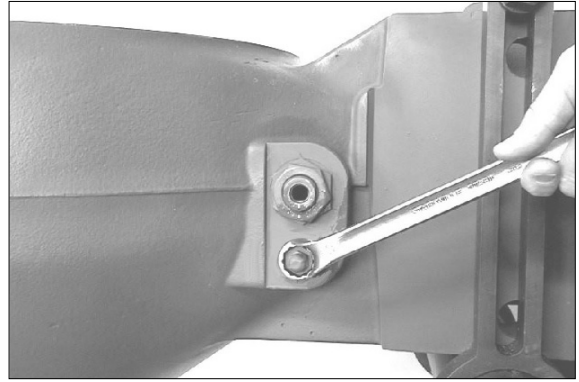

- ② Loosen hexagon nut.

※ Step (Figure 7577AAXF103~107) to be made on both sides.

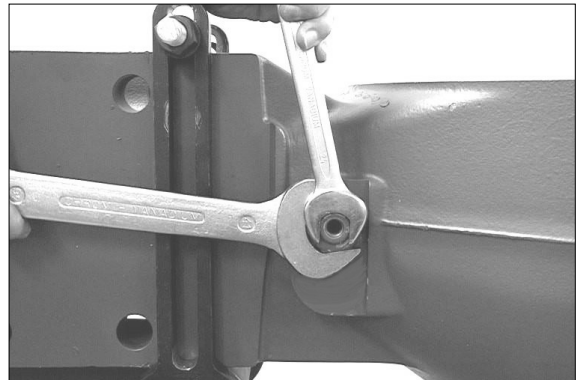

- ③ Loosen union screw.

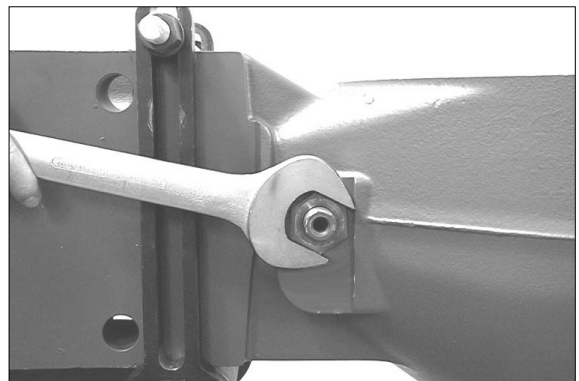

- ④ Loosen pipe union and remove released brake tube from the axle casing.

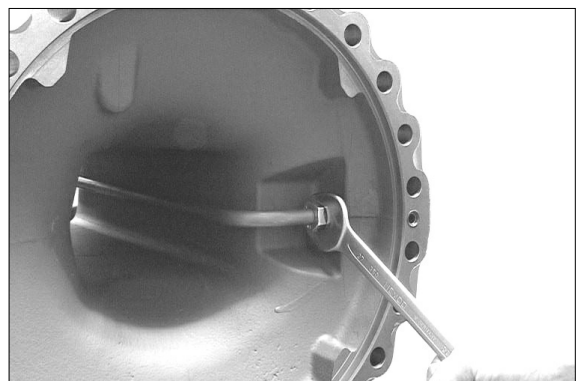

- ⑤ Remove vent valve from the connection part.

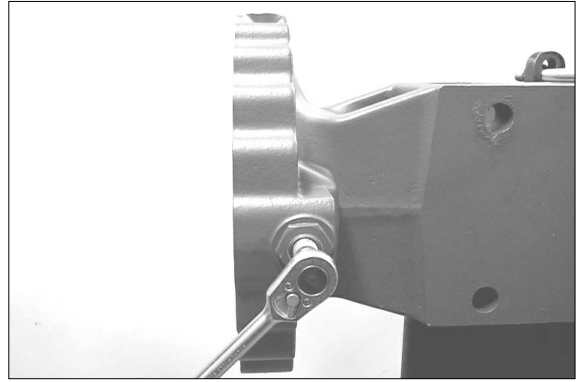

7577AAXF106

- ⑥ Loosen connection part and remove it from the axle casing.

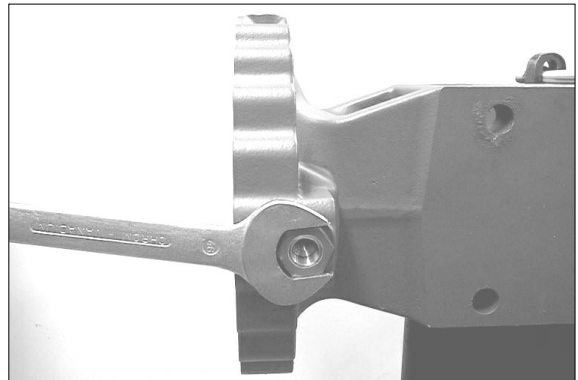

7577AAXF107

4) REASSEMBLY OF BRAKE TUBES AND DIFFERENTIAL CARRIER

(1) Reassembly of brake tubes

① Preassemble connection part as shown in opposite figure.

- 1 Vent valve
- 2 Connection part
- 3 O-Ring
- 4 Rectangular ring

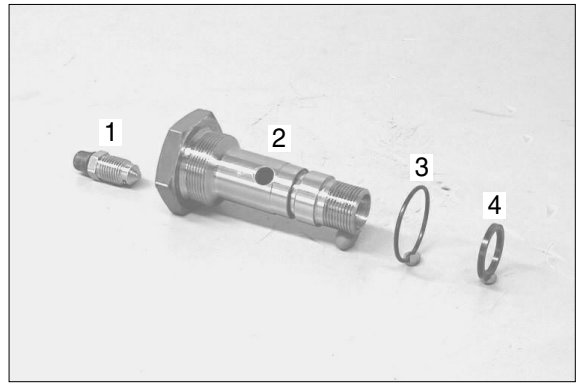

7577AAXF108

※ Step (Figure 7577AAXF108~114) is to be made on both output sides.

② Install connection part.

- Tightening torque : 13.3kgf · m
(95.9lbf · ft)

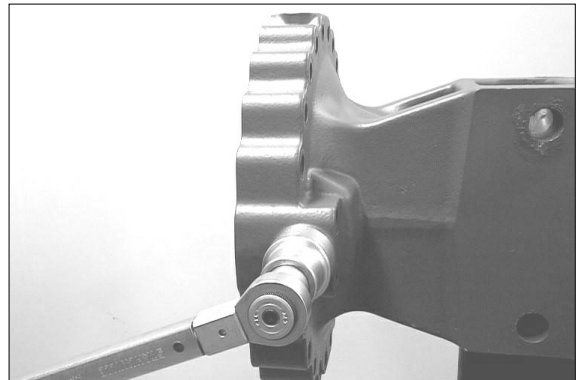

7577AAXF109

③ Provide union screw with new O-ring and install it.

- Tightening torque : 15.3kgf · m
(111lbf · ft)

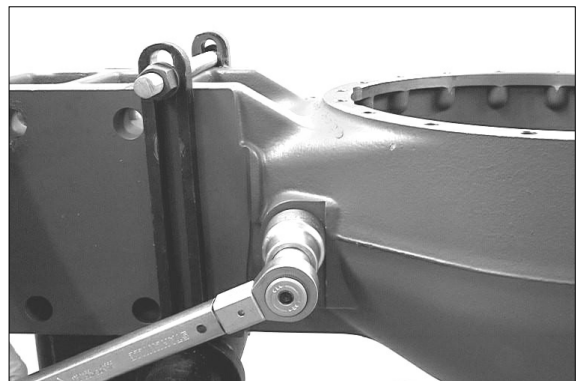

7577AAXF110

④ Insert O-ring (see arrow) into the annular groove of the brake tube.

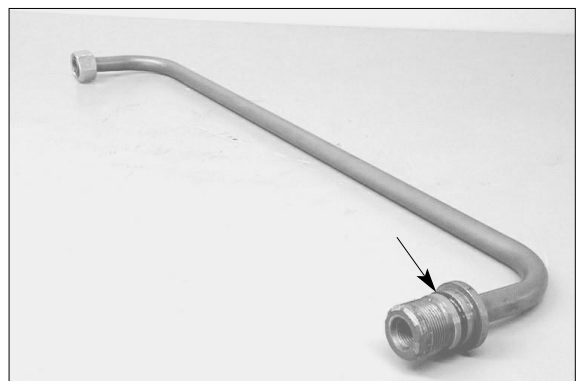

7577AAXF111

- ⑤ Insert brake tube into the axle casing, assembling the connection part (see arrow 1) through the union screw (see arrow 2).

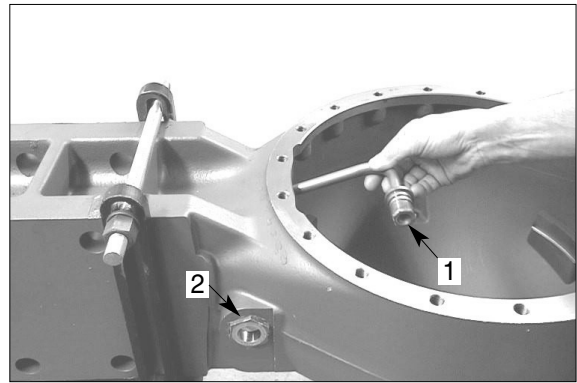

- ⑥ Fasten brake tube by means of hexagon nut and union nut (see below figure).

· Tightening torque : 10.2kgf · m
(73.8lbf · ft)

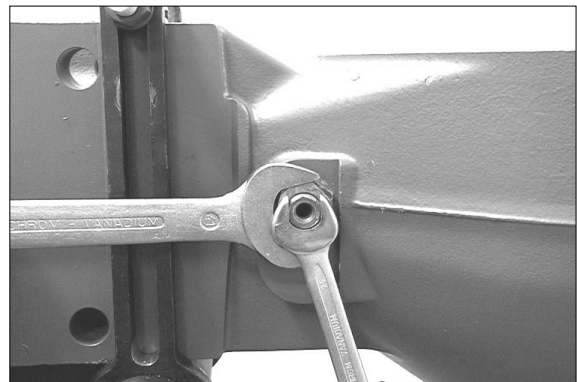

· Tightening torque : 8.2kgf · m
(59lbf · ft)

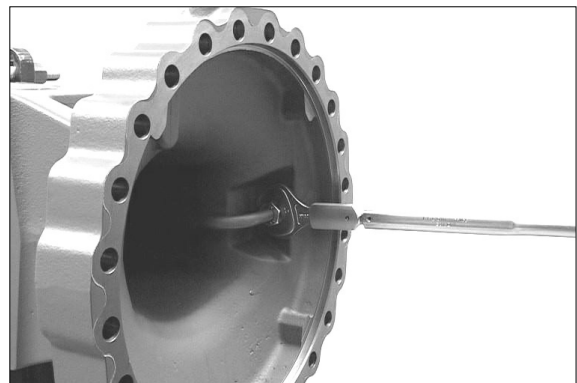

- ⑦ Preassemble screw plug as shown in opposite figure.

- 1 O-Ring
- 2 Screw plug
- 3 Vent valve

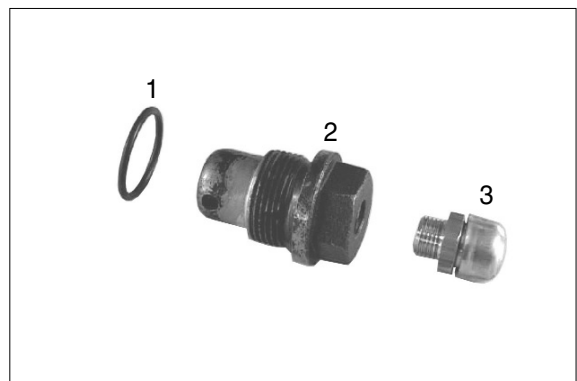

⑧ Install screw plug.

- Tightening torque : 7.1kgf · m
(51.6lbf · ft)

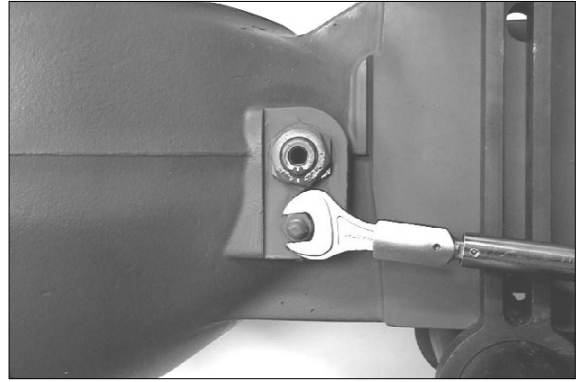

7577AAXF116

(2) Reassembly of differential carrier

- ※ If crown wheel or drive pinion are damaged, both parts have to be replaced together.

For new installation of a complete bevel gear set pay attention to the same pair number of drive pinion and crown wheel.

Determine shim thickness for a perfect tooth contact pattern

- ※ Make the following measuring steps at maximum accuracy.

Inexact measurements result in a faulty tooth contact pattern and require a repeated disassembly and reassembly of the drive pinion as well as of the differential.

- ① Install adapter pieces (1) and preliminarily fasten the bearing bracket by means of hexagon screws.

Then install stop washer (4) and measuring pin (3) and assemble measuring shaft (2) (see sketch).

- ※ Special tool

Adapter pieces	5870 500 044
Measuring shaft	5870 500 001
Measuring pin	5870 351 016
Stop washer	5870 351 029

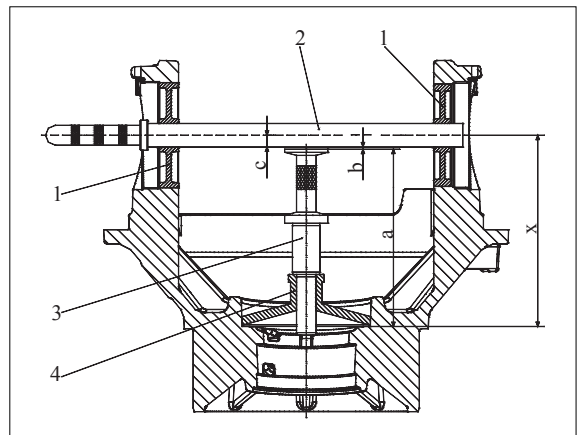

7577AAXF117

- ② Determine gap (dimension **b**) between measuring shaft and measuring pin by means of feeler gauge.

Dimension **b** e.g. 0.20mm

EXAMPLE A :

Dimension **a** (= Measuring pin + stop washer) 206.00mm
 Dimension **b** + 0.20mm
 Dimension **c** + 15.00mm
results in dimension X = 221.20mm

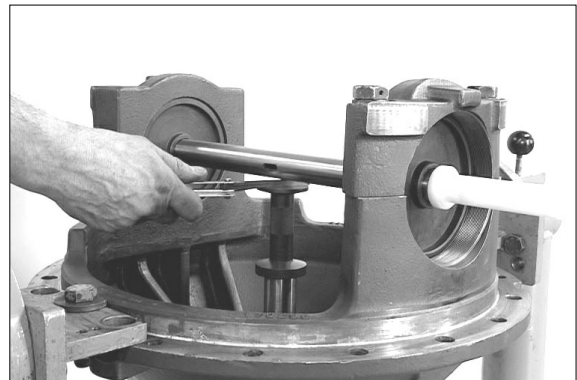

7577AAXF118

- ③ Determine dimension I (bearing width).

Dimension I e.g. 39.05mm

※ Special tool

Digital depth gauge 5870 200 072

Gauge blocks 5870 200 066

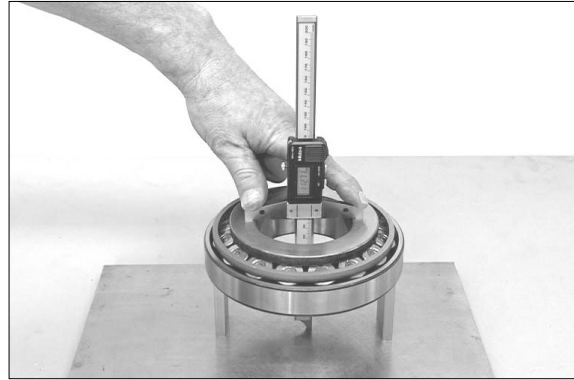

7577AAXF119

- ④ Read dimension II (dimension for pinion).

Dimension II e.g. 181.05mm

EXAMPLE B :

Dimension I 39.05mm

Dimension II + 181.05mm

results in dimension Y = 220.10mm

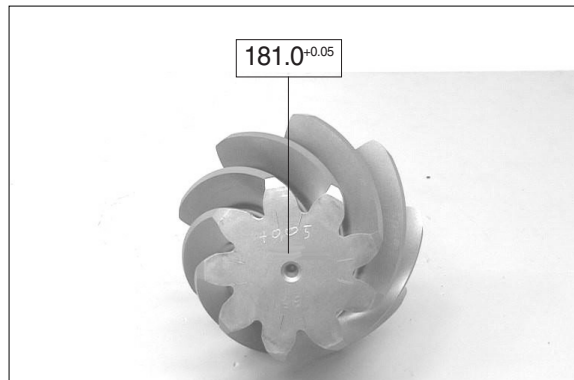

7577AAXF120

EXAMPLE C :

Dimension X 221.20mm

Dimension Y - 220.10mm

Difference = shim e.g. s = 1.10mm

Install the drive pinion

- ⑤ Place determined shim e.g. s = 1.10mm into the bearing bore.

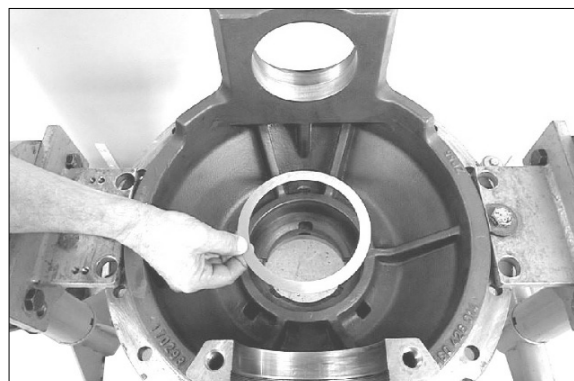

7577AAXF121

- ⑥ Undercool bearing outer ring and insert it into the bearing bore until contact.

※ Special tool

Driver 5870 058 060

Handle 5870 260 002

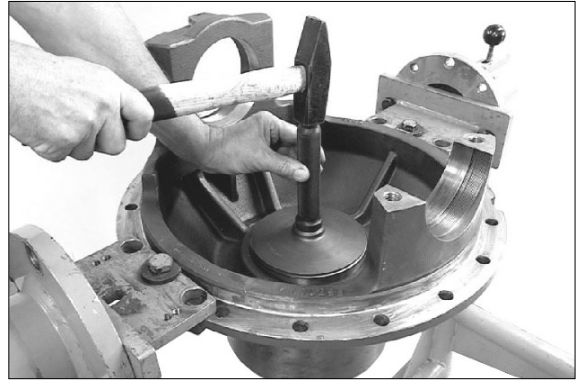

7577AAXF122

- ⑦ Undercool bearing outer ring on the input flange side and insert it until contact.

※ Special tool

Driver 5870 058 079

Handle 5870 260 002



7577AAXF123

- ⑧ Press bearing inner ring on the drive pinion until contact.

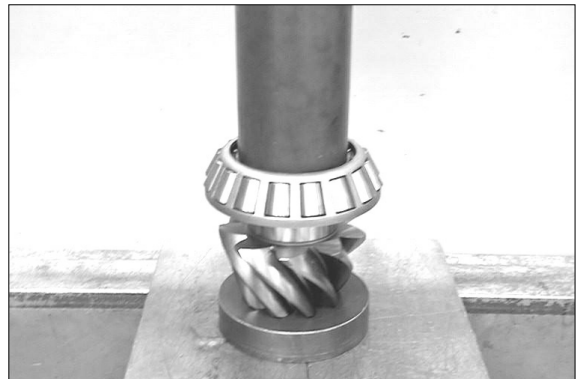

7577AAXF124

Adjust rolling moment of drive pinion bearing 0.15 ~ 0.31kgf · m (Figure 7577AAXF125~133) :

- ⑨ Assemble spacer ring (e.g. s = 8.10mm).

※ As per experience the required rolling moment is obtained by use of the spacer ring (e.g. s = 8.10mm) available at disassembly.

However, a later checking of the rolling moment is imperative.

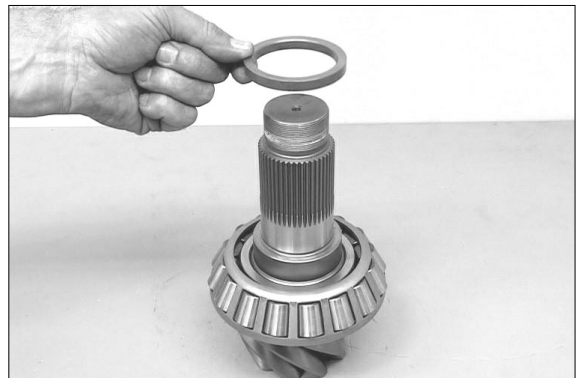

7577AAXF125

- ⑩ Insert preassembled drive pinion into the axle drive housing and assemble the heated bearing inner ring until contact.



7577AAXF126

- ⑪ Press dust protection on the input flange until contact.

※ Special tool
Driver

5870 056 003

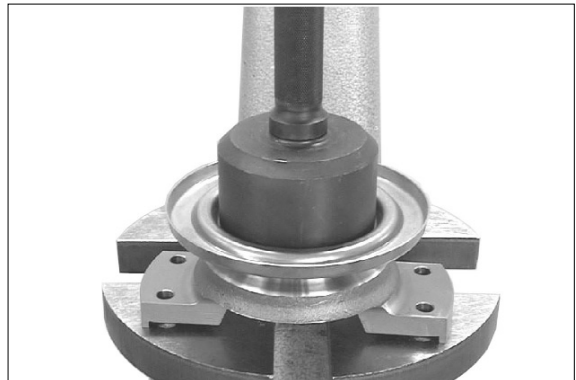

7577AAXF127

- ⑫ Assemble input flange.

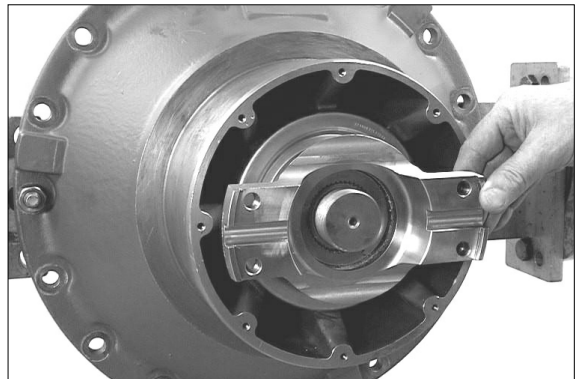

7577AAXF128

- ⑬ Assemble washer.

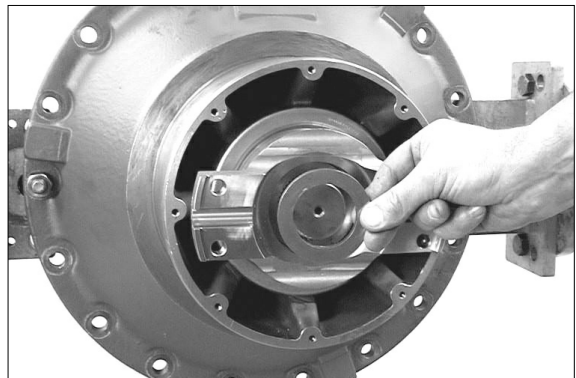

7577AAXF129

- ⑭ Unscrew hexagon nut by hand and tighten it.

· Tightening torque : 122kgf · m
(885lbf · ft)

※ Special tool

Slotted nut wrench 5870 401 139

Fixture 5870 240 002

※ When tightening rotate drive pinion in both directions several times.

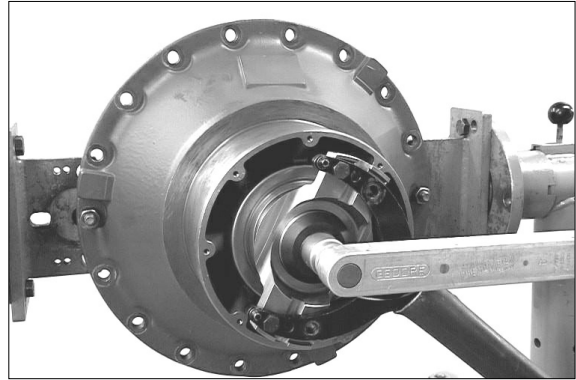

7577AAXF130

- ⑮ Check rolling moment (0.15~0.30kgf · m).

※ For new bearings it should be tried to achieve the max. value of the rolling moment.

▲ If the required rolling moment is not obtained, correct it with an adequate spacer ring (Figure 7577AAXF125), according to the following indications :

Rolling moment too low - install a thinner spacer ring

Rolling moment too high - install a thicker spacer ring.

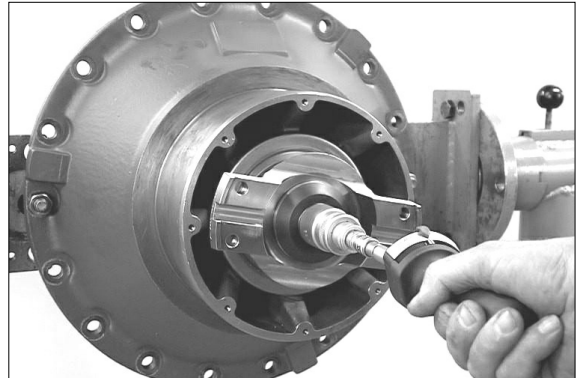

7577AAXF131

- ⑯ Then loosen the slotted nut again and pull input flange from the drive pinion.

Install shaft seal with the sealing lip showing to the oil chamber (downwards).

※ Special tool

Driver 5870 048 233

※ The exact installation position of the shaft seal will be obtained by using the exact driver.



7577AAXF132

▲ Just before the installation wet the outer diameter of the shaft seal with spirit and fill the space between sealing and dust lip with grease.

- ⑰ Assemble input flange and finally fasten it by means of washer and slotted nut.

· Tightening torque : 122kgf · m(885lbf · ft)

▲ Apply Loctite (Type No. 262) onto the thread of the slotted nut.

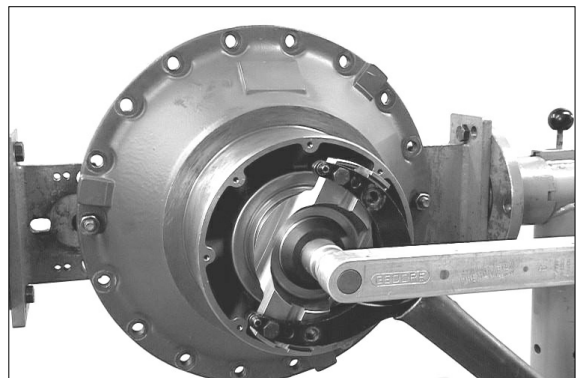

7577AAXF133

Reassembly of limited slip differential

- ⑱ Place both thrust washers into the differential housing.
- ※ Prior to installation all single parts of the differential must be oiled.

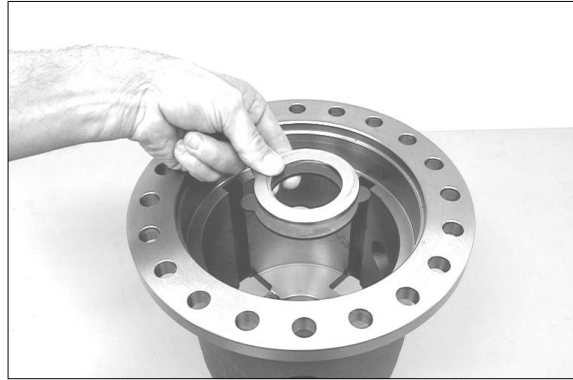

- ⑲ Starting with an outer clutch disc install alternately the outer and inner clutch discs.
- ⚠ Thickness of the disc pack must be identical on both sides.

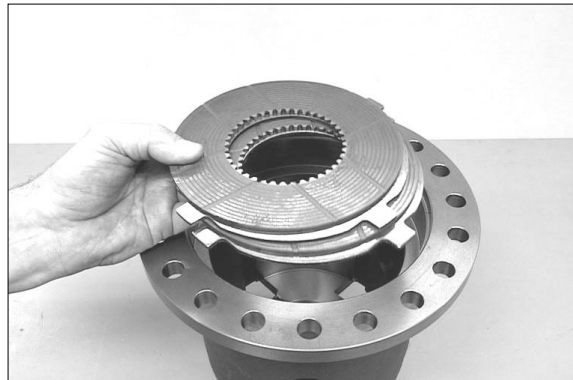

- ⑳ Put on the pressure ring.

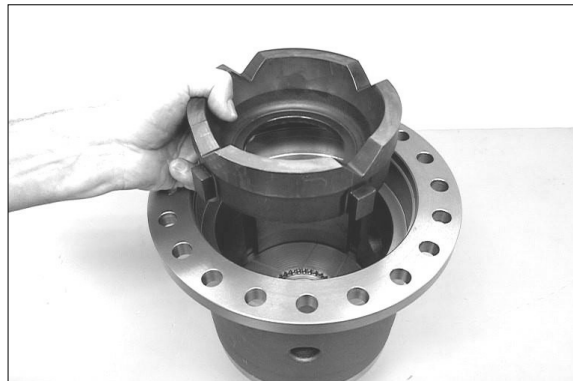

- ㉑ Insert axle bevel gear until contact and at the same time assemble all inner clutch discs with the spline.

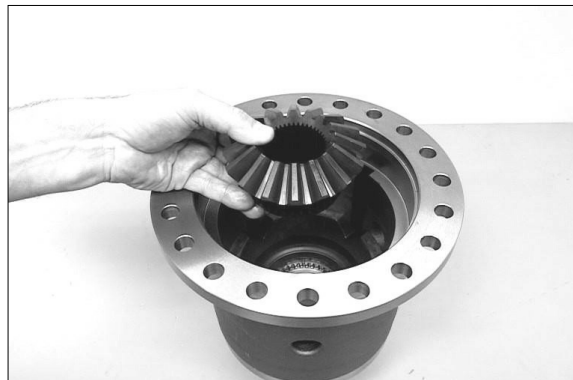

- ② Preassemble differential spider and insert it into the differential housing.

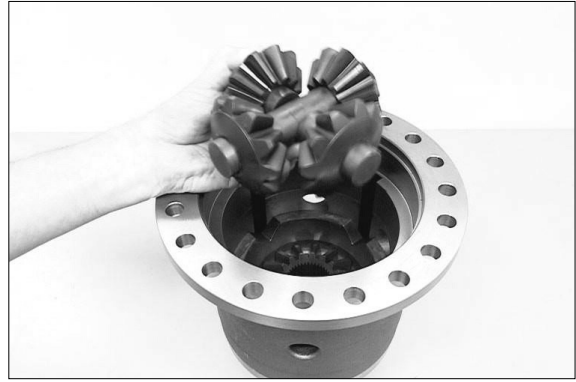

7577AAXF138

- ③ Put on the second axle bevel gear.



7577AAXF139

- ④ Insert the second pressure ring into the differential housing.



7577AAXF140

- ⑤ Starting with an inner clutch disc install alternately the inner and outer clutch discs.

- ▲ Thickness of the clutch disc pack must be identical on both sides.

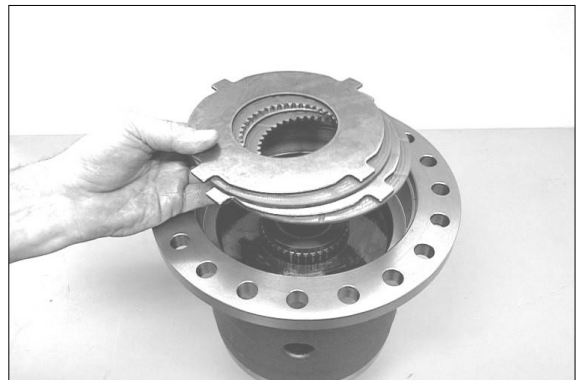

7577AAXF141

Determine disc clearance 0.2~0.8mm

- ②⑥ Determine dimension I, from mounting face of the differential housing to plane face of the outer clutch disc.

Dimension I e.g 44.30mm

※ Special tool
Digital depth gauge 5870 200 072

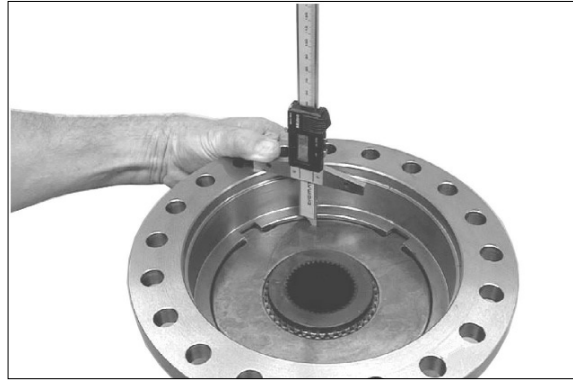

7577AAXF142

- ②⑦ Determine dimension II, from contact surface of the outer clutch disc to the mounting face of the housing cover.

Dimension II e.g 43.95mm

EXAMPLE D :

Dimension I 44.30mm

Dimension II - 43.95mm

Difference = Disc clearance = 0.35mm

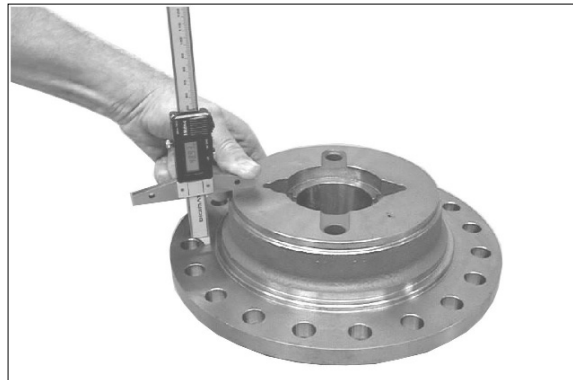

7577AAXF143

※ If the required disc clearance is not obtained, correct it with the adequate outer clutch discs (s = 2.7, s = 2.9, s = 3.0, s = 3.1 or s = 3.3 mm), taking care that the difference in thickness between the left and the right disc pack must only be 0.01 at a maximum.

- ②⑧ Fix both thrust washers with grease into the recess of the housing cover.



7577AAXF144

- ⑳ Put on the housing cover and fasten it by means of cap screws(2EA).

· Tightening torque (M10/8.8) :
4.7kgf · m(33.9lbf · ft)



7707AAXF015

- ㉑ Heat crown wheel and install it until contact.

※ Special tool
Adjusting screws 5870 204 040



7577AAXF145

- ㉒ Fix differential by means of press and fasten crown wheel by means of **new** locking screws.

· Tightening torque : 41.8kgf · m
(302lbf · ft)

▲ Only use of new locking screws is permissible.



7577AAXF146

- ㉓ Press on both bearing outer rings until contact.



7577AAXF147

③③ Insert differential into the axle drive housing by means of lifting tackle.

※ Special tool

Lifting tackle

5870 281 013

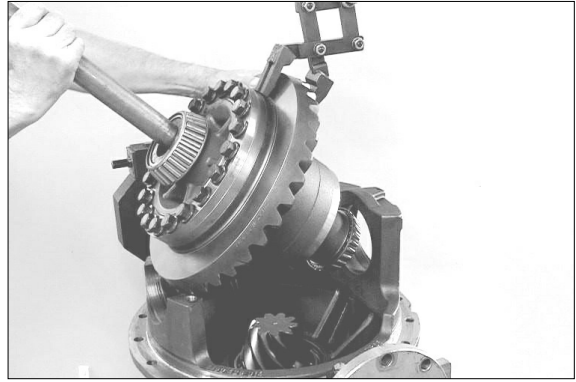

7577AAXF148

③④ Place bearing outer ring into the axle drive housing.

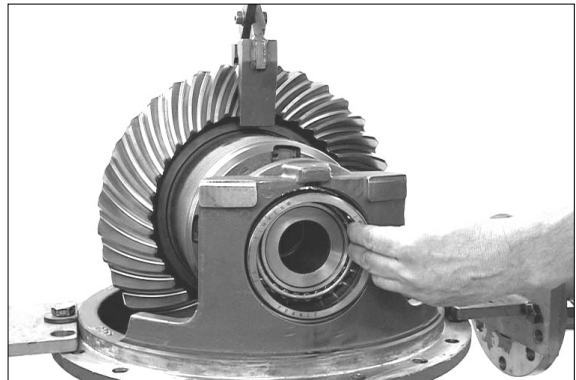

7577AAXF149

③⑤ Preliminarily fix the bearing outer ring by means of adjusting nut.

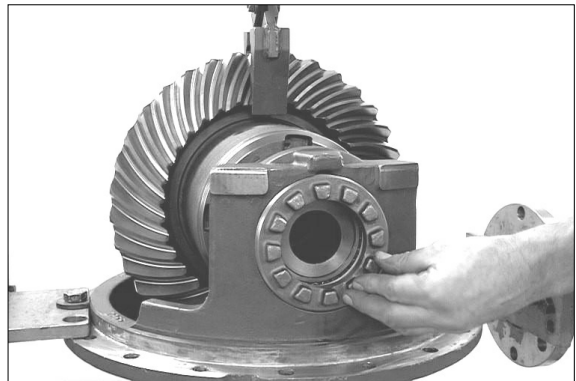

7577AAXF150

③⑥ Install crown wheel-sided bearing outer ring.

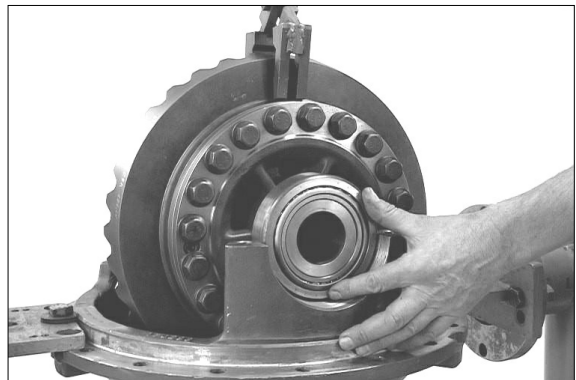

7577AAXF151

- ③⑦ Preliminarily fix the crown wheel-sided bearing outer ring by means of the second adjusting nut.

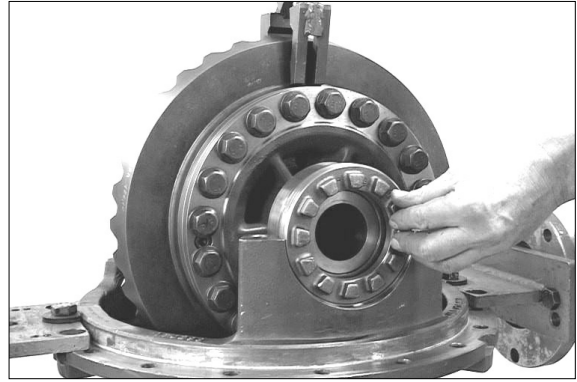

7577AAXF152

- ③⑧ Put on bearing bracket and fasten it by means of hexagon screws and washers.

- Tightening torque (M16/10.9) :
28.6kgf · m(207lbf · ft)

- ※ Pay attention to clearance of the adjusting nut.

▲ Apply Loctite (Type No. 262) onto threads of the hexagon screws.

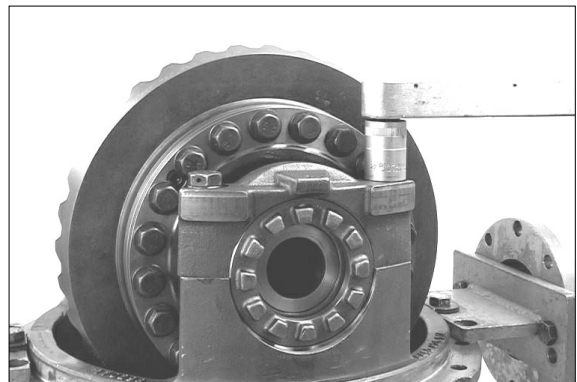

7577AAXF153

Adjustment of backlash and bearing preload

- ③⑨ Place dial indicator right-angled at the outer diameter of the tooth flank (crown wheel).

Then install both adjusting nuts only to such an extent that the required backlash - see the value etched on the outer diameter of the crown wheel - is reached.

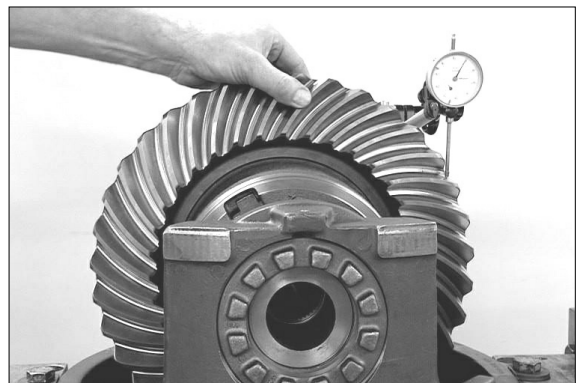

7577AAXF154

- ※ Special tool
Magnetic stand 5870 200 055
Dial indicator 5870 200 057
Socket spanner 5870 656 079

- ※ At this step rotate the differential several times.

- ④⑩ Determine bracket width and correct it on both adjusting nuts, if required.

Bracket width 418^{-0.05} mm

- ※ Special tool
Caliper gauge 5870 200 058

Then check backlash once again.

- ※ Adjusting of the bracket width results in the required bearing preload.

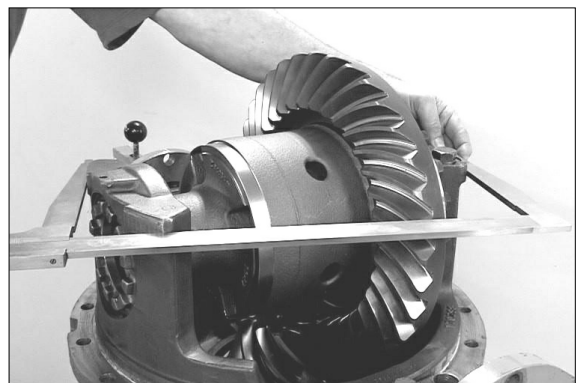

7577AAXF155

- ④① Cover some tooth flanks of the crown wheel with marking ink and roll crown wheel in both directions over the drive pinion.

Compare the obtained tooth contact pattern with the examples on page 3-228

- ▲ If the tooth contact pattern differs, there has been a measuring error at determination of the shim (Figure 7577AAXF121/page 3-216), what is imperative to be corrected.

- ④② Secure both adjusting nuts by means of slotted pins.

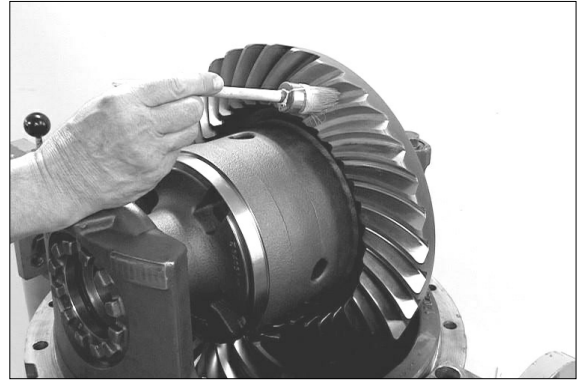

7577AAXF156

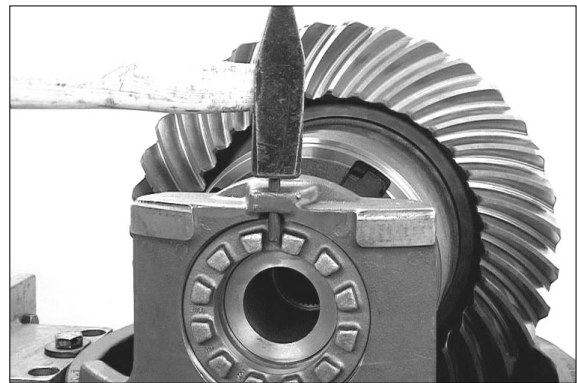

7577AAXF157

- ④③ Install two adjusting screws and insert differential carrier into the axle casing until contact by means of lifting tackle.

※ Special tool

Adjusting screws 5870 204 023

Lifting tackle 5870 281 044

※ Observe radial location (see marking Page 3-204 / Figure 7577AAXF081).

- ▲ Apply sealing compound (Three Bond Type 1215) on mounting face.

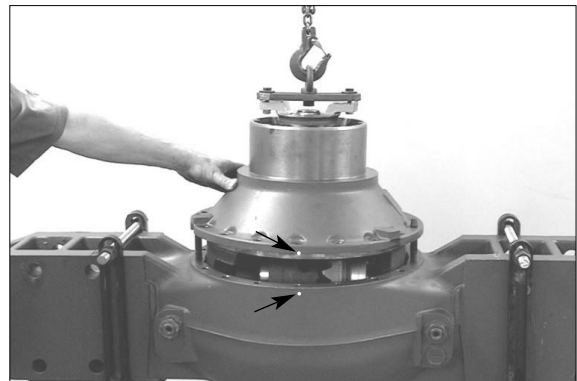

7577AAXF158

- ④④ Fasten differential carrier by means of new locking screws.

· Tightening torque : 25.5kgf · m
(184lbf · ft)

- ▲ Only use of the new locking screws is permissible.

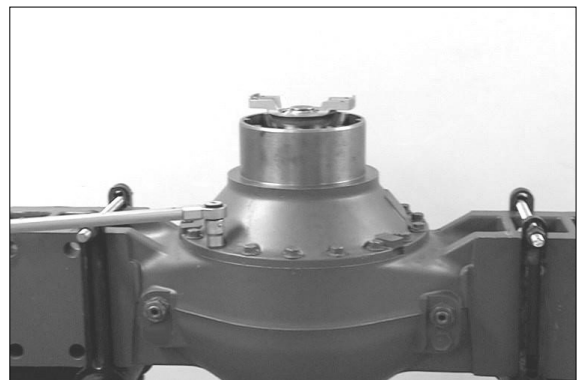

7577AAXF159

- ④⑤ Insert stub shaft into spline of the axle bevel gear until contact.

Then fix O-ring (see arrow) by means of grease into the recess of the axle casing.

- ※ Step (Figure 7577AAXF160 ~ 163) is to be made on both output sides.

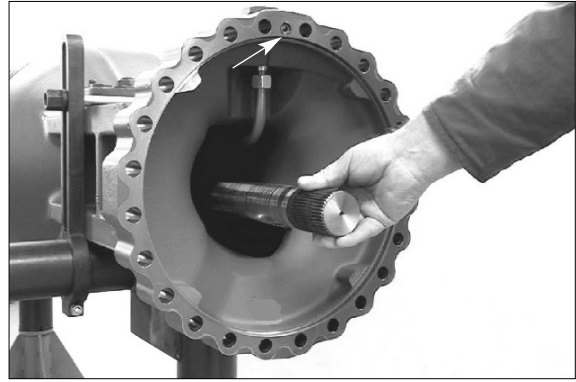

7577AAXF160

- ④⑥ Thrust washer(s) removed at disassembly have to be fixed in the sun gear shaft by means of grease.



7577AAXF161

- ④⑦ Place complete output by means of lifting tackle to the axle casing until contact.

- ※ Special tool
Lifting bracket 5870 281 043

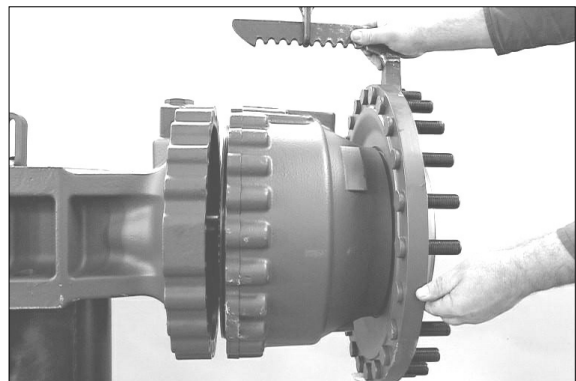

7577AAXF162

- ④⑧ Fasten output by means of hexagon screws and washers.

- Tightening torque (M18/10.9) :
39.8kgf · m(288lb · ft)

- ※ Prior to putting into operation of the axle, fill oil in accordance with lubrication instructions.

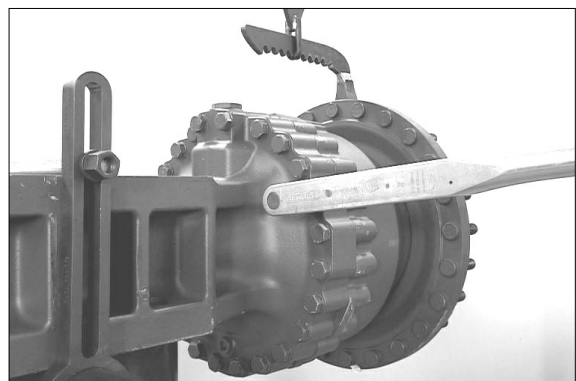

7577AAXF163

※ **BACKLASH CHECK**

- Applied the paint (or red lead) on the surface of several bevel gear teeth.
- Turn the pinion gear and check the contact pattern.

Correct pattern

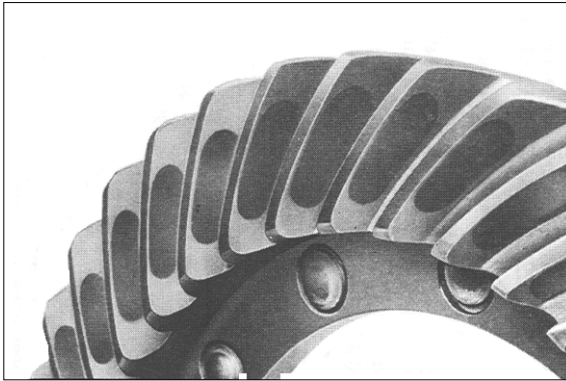

WTHAX16

Concave side



WTHAX17

Convex side

※ **ADJUSTMENT**

Incorrect pattern : high contact

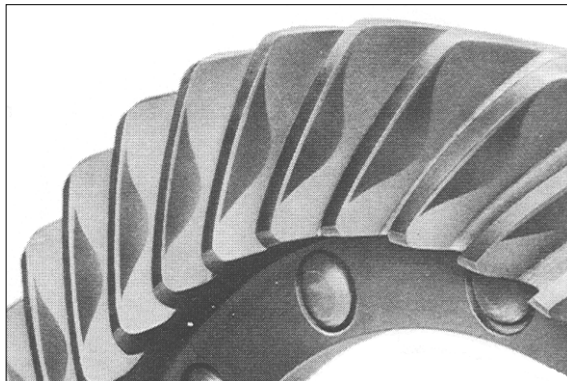

WTHAX18

Concave side

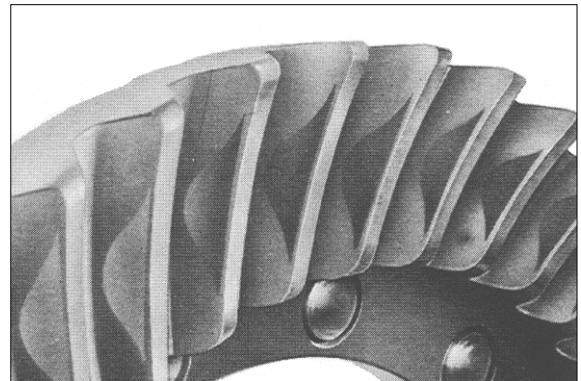

WTHAX19

Convex side

- Reduce the distance (-)

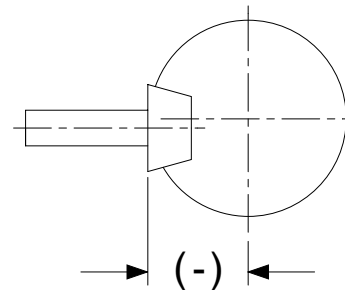

WTHAX20

Incorrect pattern, low contact

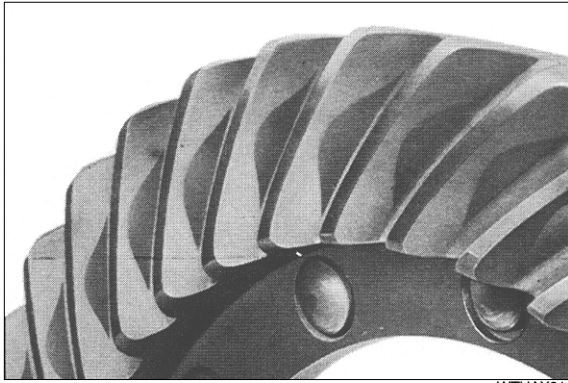

WTHAX21

Concave side

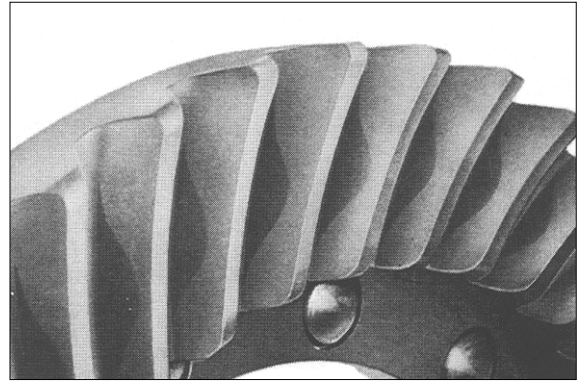

WTHAX22

Convex side

- Add the distance (+)

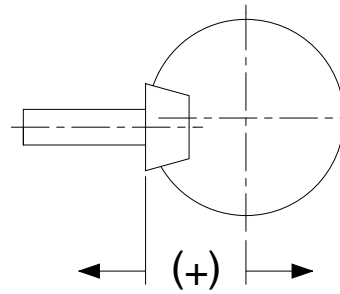

WTHAX23

• REAR AXLE

1) DISASSEMBLY OF OUTPUT AND BRAKE

(1) Fasten axle on assembly truck.

※ Special tool

Assembly truck 5870 350 000

Holding fixtures 5870 350 077

Clamps 5870 350 075

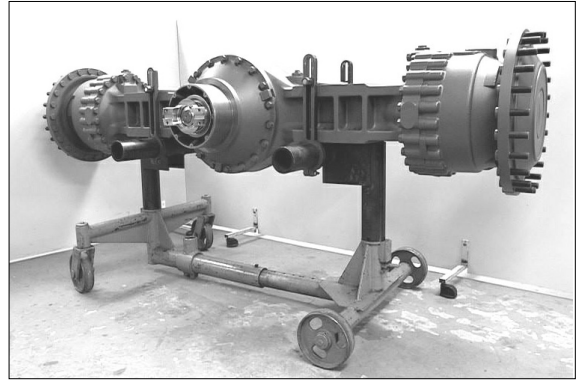

7577AAXF001

(2) Loosen screw plugs (3EA, see Figure 7577AAXF002 and 003) and drain oil from axle casing.

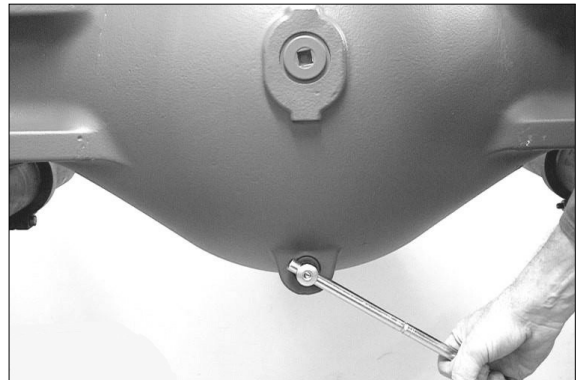

7577AAXF002

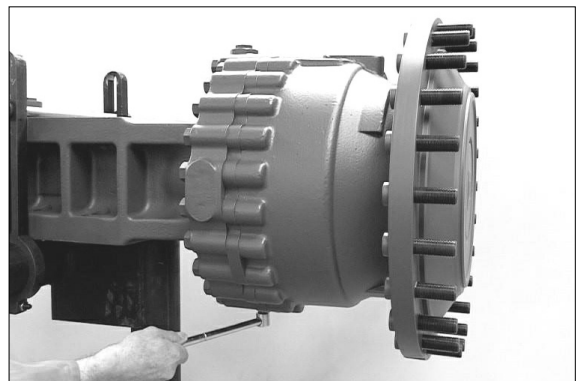

7577AAXF003

(3) Press off cover from the output shaft.

※ Special tool

Pry bar set 5870 345 065

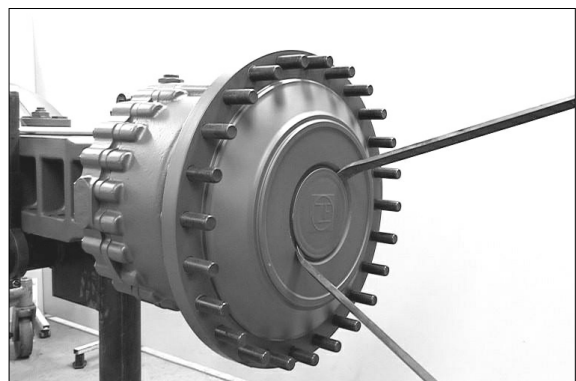

7577AAXF004

(4) Pull slotted pin by means of the striker out of the bore in the slotted nut.

※ Special tool

Striker

5870 650 001

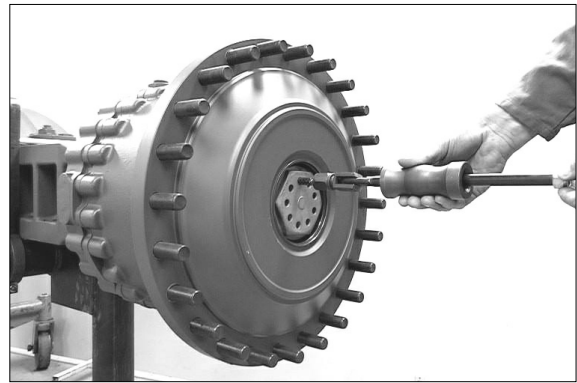

7577AAXF005

(5) Loosen slotted nut.

※ Special tool

Socket spanner

5870 656 077

Centering bracket

5870 912 028

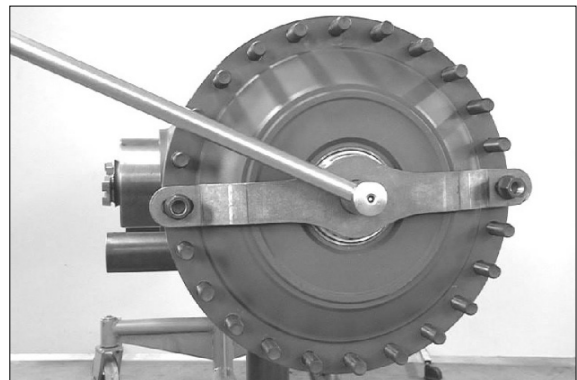

7577AAXF006

(6) Secure output by means of lifting tackle and loosen hexagon screws.

※ Special tool

Lifting bracket

5870 281 043

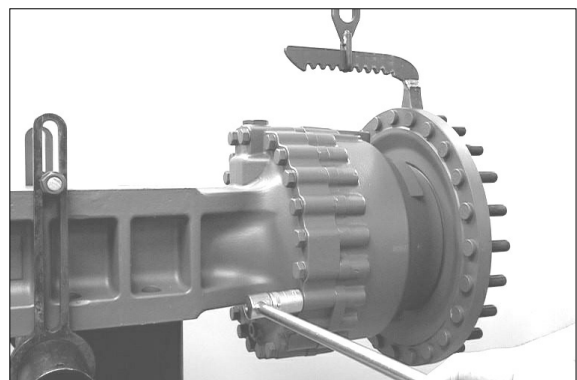

7577AAXF007

(7) Separate complete output from the axle casing.

※ Pay attention to released O-ring (see arrow).

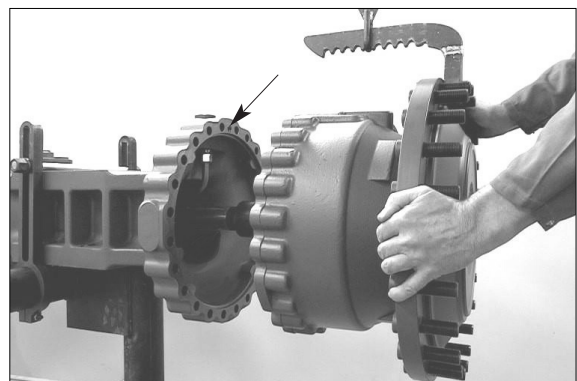

7577AAXF008

- (8) Pull stub shaft out of the sun gear shaft.
※ Pay attention to possibly released shim(s).

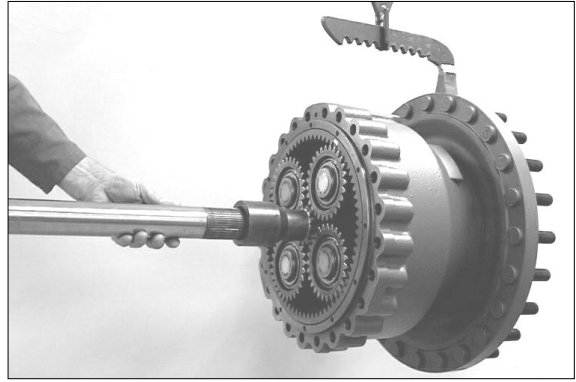

7577AAXF009

- (9) Remove shim(s) from the sun gear shaft.



7577AAXF010

- (10) Pull sun gear shaft out of the planet gears.



7577AAXF011

- (11) Lift planet carrier out of the brake housing.

- ※ Special tool
Internal extractor 5870 300 019

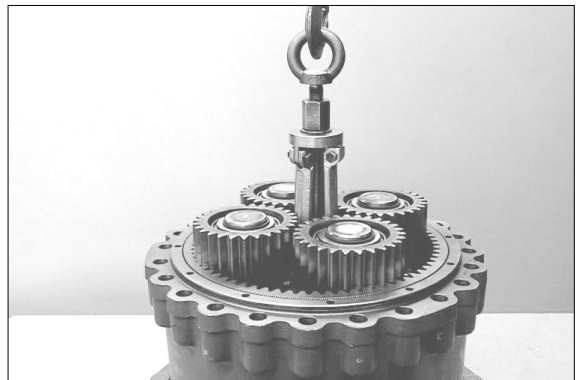

7577AAXF012

(12) Squeeze out the retaining ring.

- ※ Special tool
Set of external pliers 5870 900 015

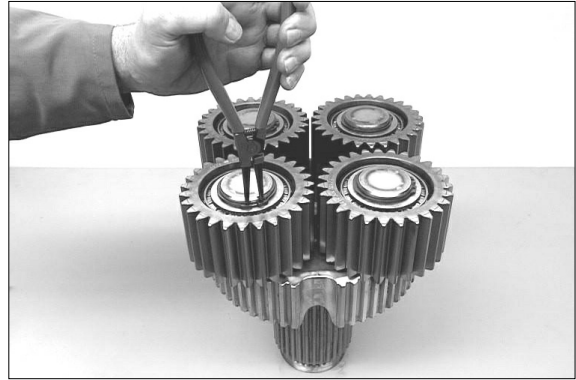

7577AAXF013

(13) Pull off the planet gear and remove the released bearing inner ring.

- ※ Special tool
Three-armed puller 5873 971 002



7577AAXF014

(14) Pull off the bearing inner ring.

- ※ Special tool
Gripping insert 5873 001 020
Back-off insert 5873 026 100

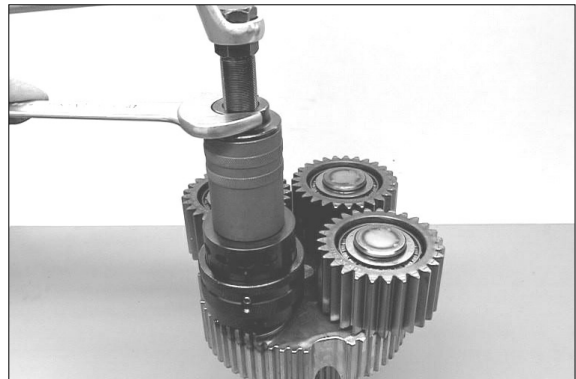

7577AAXF015

(15) Separate ring gear from the brake housing by means of two-armed puller.

- ※ Special tool
Two-armed puller 5870 970 007



7577AAXF016

(16) Remove O-rings (see arrows) from the annular grooves of the ring gear.

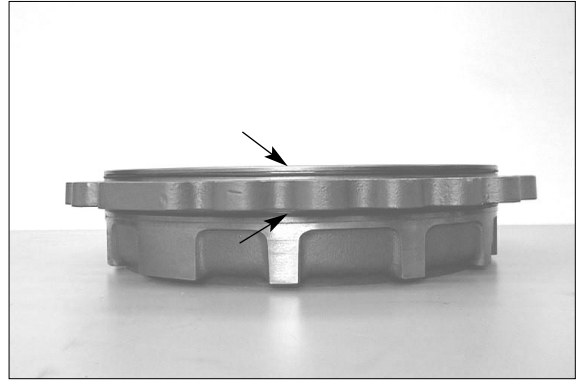

7577AAXF017

(17) Remove O-ring (see arrow) from the recess of the brake housing.



7577AAXF018

(18) Take the disc pack out of the brake housing.

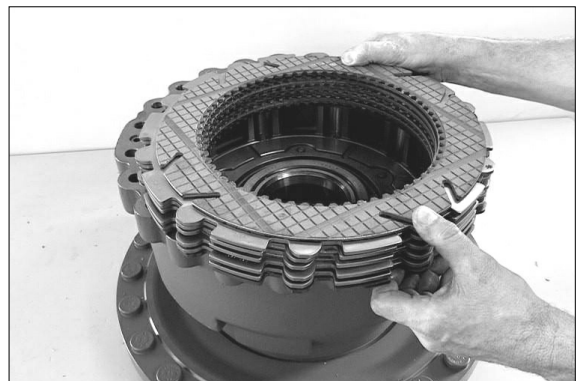

7577AAXF019

(19) Install slotted pins (6EA) in the support shim until they are flush-mounted.



7577AAXF020

(20) Squeeze out the circlip.

※ Special tool

Set of external pliers

5870 900 016

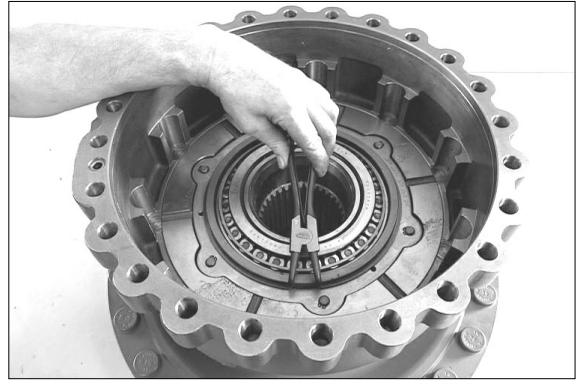

7577AAXF021

(21) Press piston out of the brake housing by means of compressed air.



7577AAXF022

(22) Press support shim out of the piston by means of the automatic piston adjusting.

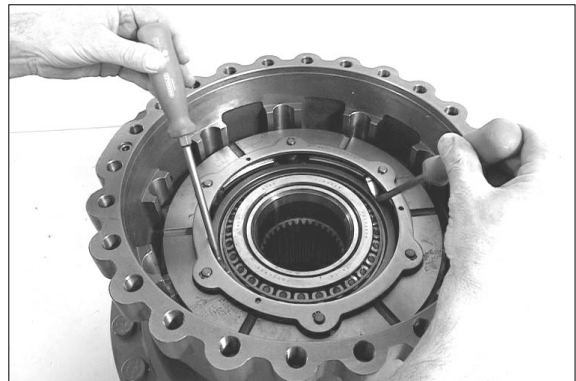

7577AAXF023

(23) Drive slotted pins (6EA) out of the support shim.

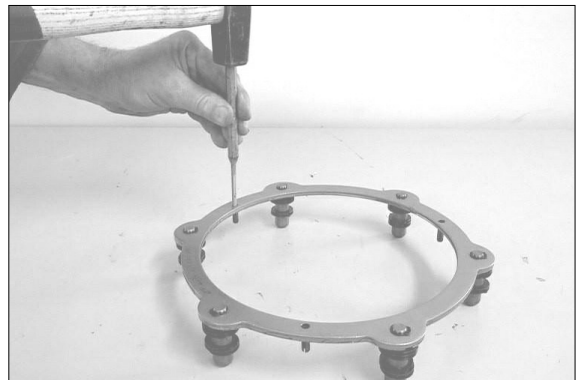

7577AAXF024

(24) Preload cup springs by means of a press and squeeze out the circlip.

※ Special tool

Assembly pliers 5870 900 051

Assembly fixture 5870 345 096

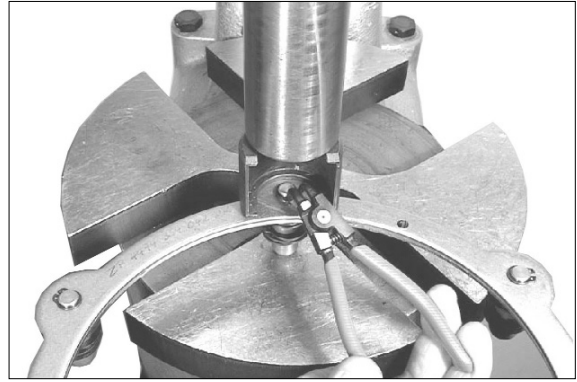

7577AAXF025

(25) Pull pin out of the support shim and remove released cup springs.



7577AAXF026

(26) Press gripping rings from the pin.

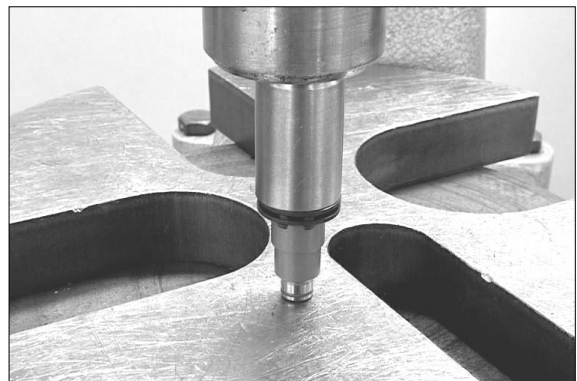

7577AAXF027

(27) Lift piston out of the brake housing.

※ Special tool

Adjusting device 5870 400 001



7577AAXF028

(28) Remove guide ring, support rings and U-rings from the annular grooves of the brake housing.

※ See below sketch for installation position of the single parts.

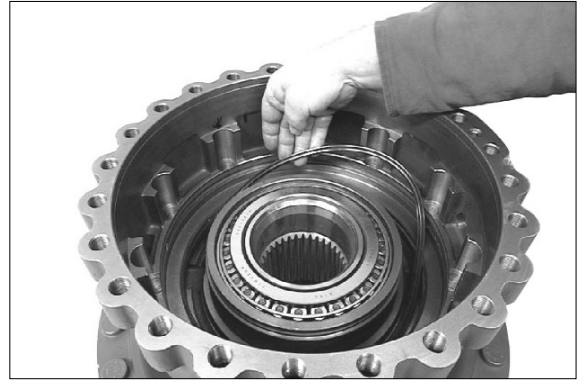

7577AAXF029

To the sketch :

- 1 Brake housing
- 2 Guide ring
- 3 Support ring
- 4 U-ring
- 5 U-ring
- 6 Support ring
- 7 Output shaft

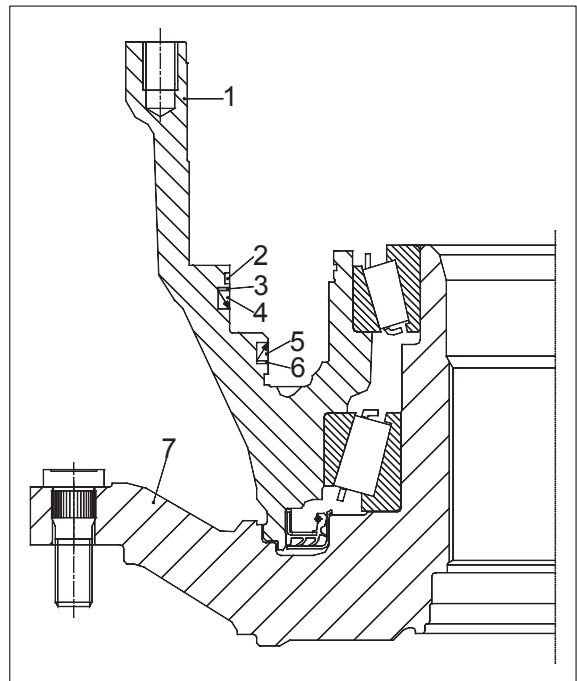

7577AAXF030

(29) Pull brake housing by means of two-armed puller from the output shaft and remove the released bearing inner ring.

※ Special tool

Two-armed puller	5870 970 007
Clamping bracket	5870 654 034
Press bush	5870 506 140



7577AAXF031

(30) Lift brake housing with lifting tackle from the output shaft.

※ Special tool

Lifting chain 5870 281 047

Eye bolts 5870 204 071

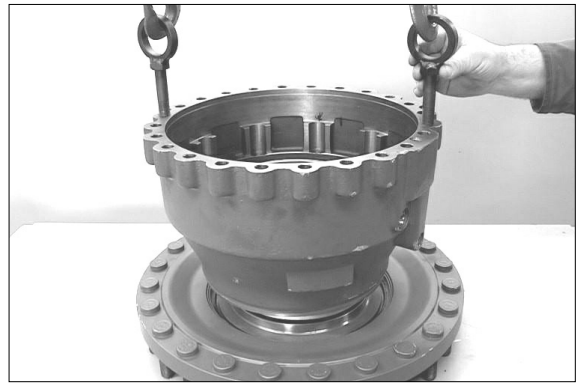

7577AAXF032

(31) If necessary drive both bearing outer rings out of the bearing bores in the brake housing.



7577AAXF033

(32) Press shaft seal out of the brake housing.

※ Special tool

Pry bar set 5870 345 065



7577AAXF034

(33) Pull bearing inner ring from the output shaft.

※ Special tool

Rapid grip 5873 014 017

Basic set 5873 004 001

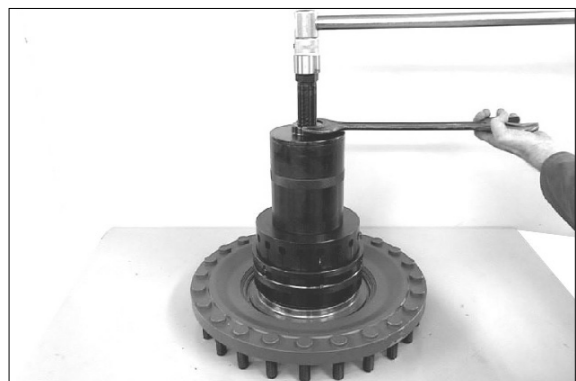

7577AAXF035

(34) Press off bearing sheet from the output shaft.

※ Special tool
Pry bar set

5870 345 065



7577AAXF036

2) REASSEMBLY OF OUTPUT AND BRAKE

(1) Insert wheel bolt into the output shaft until contact.

※ Special tool

Wheel bolt puller-basic set 5870 610 010

Insert (3/4"-16 UNF) 5870 610 005

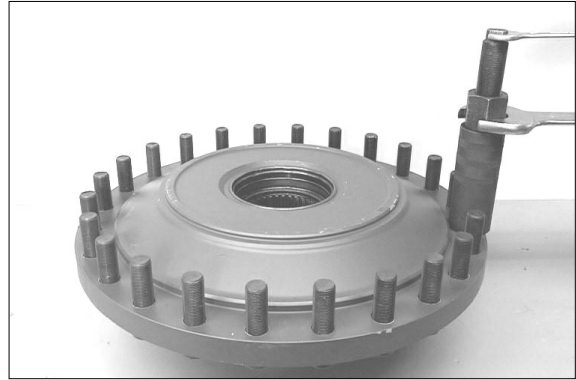

7577AAXF037

(2) Assemble bearing sheet (shaft seal).



7577AAXF038

(3) Press bearing sheet over the collar of the output shaft.

※ Special tool

Pressure ring 5870 506 141

※ The exact installation position of the bearing sheet will be obtained by using the specified pressure ring.

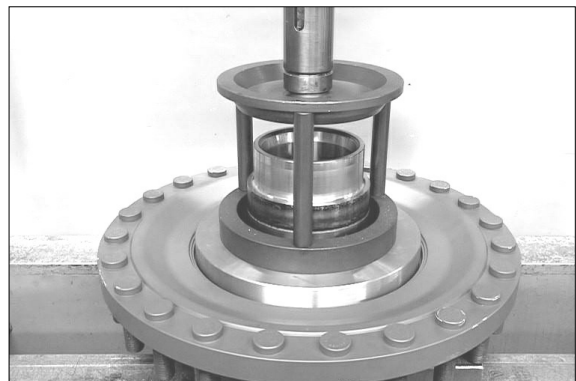

7577AAXF039

(4) Heat the roller bearing and install it until contact.

※ After cooling-down the bearing has to be installed subsequently.



7577AAXF040

- (5) Press both bearing outer rings into the brake housing until contact.

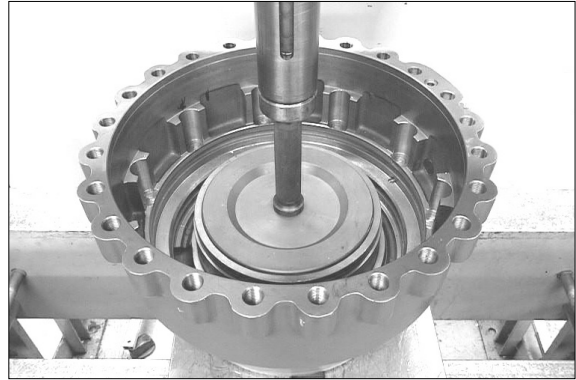

7577AAXF041

- (6) Install shaft seal with the sealing lip showing to the oil chamber (see below sketch).

- ※ Special tool
Driver 5870 051 052
- ※ The exact installation position of the shaft seal will be obtained by using the specified driver.

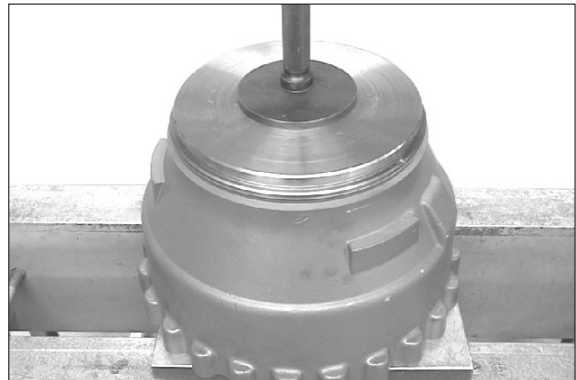

7577AAXF042

- ▲ **Just before the installation wet the outer diameter of the shaft seal with spirit.**

To the sketch :

- 1 Brake housing
- 2 Shaft seal
- * Grease filling

- ※ Fill the space between sealing and dust lips with grease.

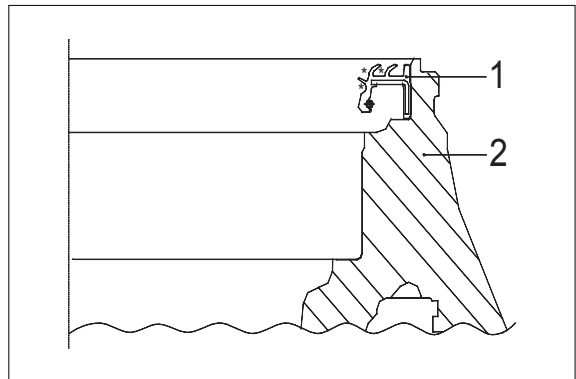

7577AAXF043

- (7) Install the preassembled brake housing by means of the lifting tackle over the output shaft until contact.

- ※ Special tool
Lifting chain 5870 281 047
Eye bolts 5870 204 071

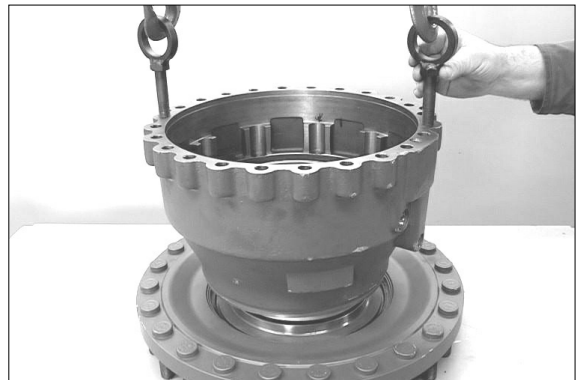

7577AAXF044

(8) Heat the roller bearing and install it until contact.

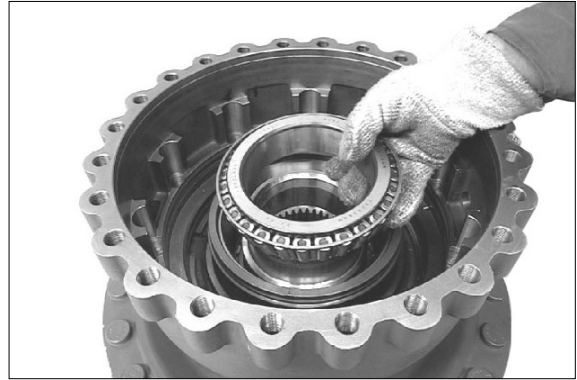

7577AAXF045

(9) Insert support and U- rings into the annular grooves of the brake housing.

※ Pay attention to the installation position, see below sketch.

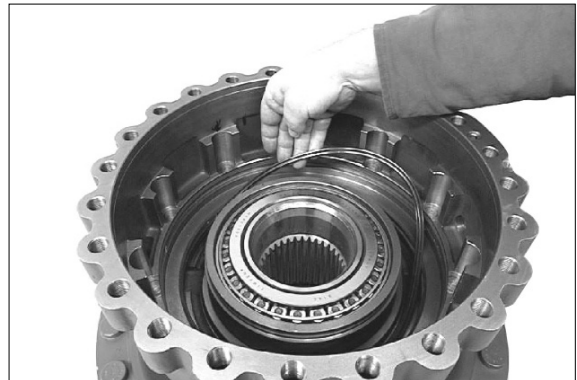

7577AAXF046

To the sketch :

- 1 Brake housing
- 2 Guide ring
- 3 Support ring
- 4 U-ring
- 5 U-ring
- 6 Support ring
- 7 Output shaft

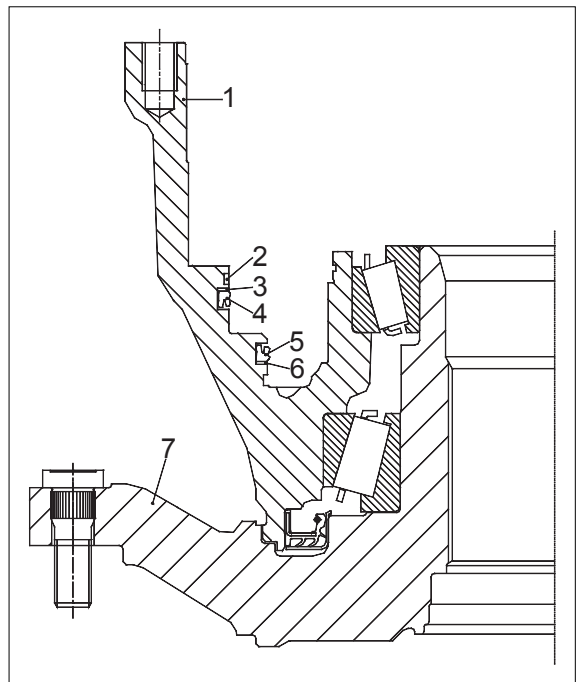

7577AAXF047

(10) Clean annular groove of the brake housing with spirit.

Then insert the guide ring into the annular groove (also see sketch page 3-242) and fix it with Loctite (Type No. 415) at its extremities.

※ Guide ring must have contact on the whole circumference.

▲ Upon installation the orifice of the guide ring must show upwards (12 o'clock).

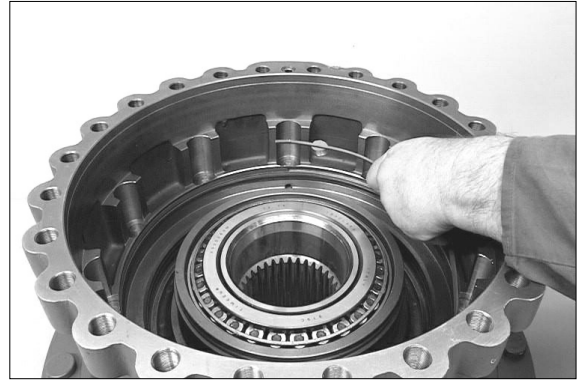

7577AAXF048

(11) Insert piston into the brake housing and install it cautiously until contact.

※ Apply sufficiently oil on the sliding surface of the piston or support rings, U-rings and guide ring (use W-10 oils).

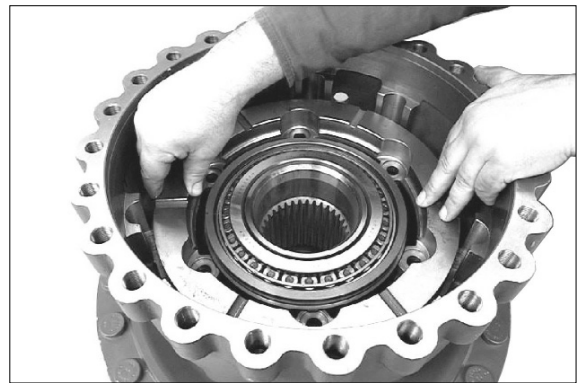

7577AAXF049

(12) Insert pins into the assembly fixture until contact.

※ Special tool

Assembly fixture 5870 345 096

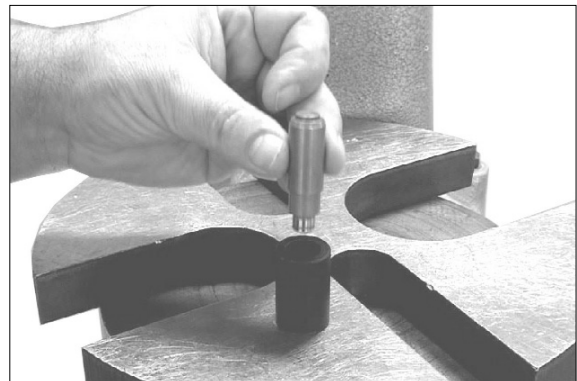

7577AAXF050

(13) Press gripping rings (4EA, see arrows) onto the pins until contact on the assembly fixture.

※ The exact installation dimension (see sketch page 3-244) of the gripping rings is obtained when using the specified assembly fixture.

▲ Observe the installation position, install gripping rings with the orifices offset by 180° to each other.

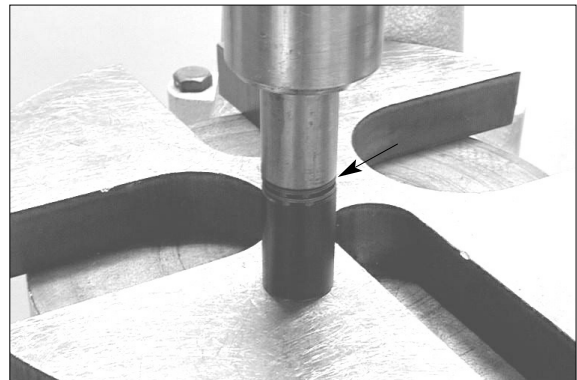

7577AAXF051

(14) Install cup springs (7 pieces each/pin).

- ※ Pay attention to the installation position of the cup springs, see below sketch.



7577AAXF052

To the sketch :

- 1 Pin
- 2 Gripping rings
- 3 Cup springs
- 4 Support shim
- 5 Circlip
- X Installation dimension gripping rings
 $10.5^{+0.3}$ mm

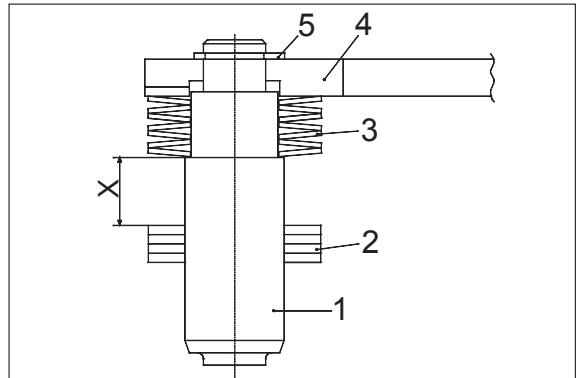

7577AAXF053

(15) Insert preassembled pins into the support shim and fix it by means of the circlip.

- ※ Special tool
Assembly pliers 5870 900 051
- ※ Pay attention to clearance of the cup springs.

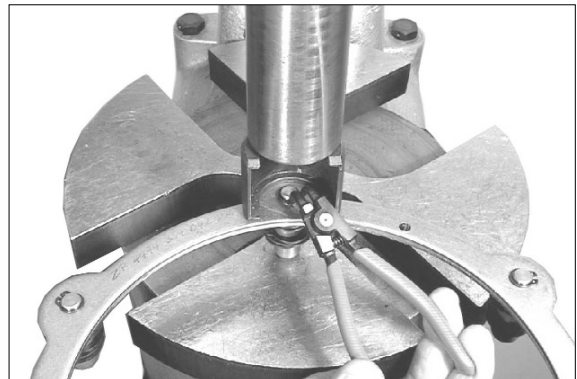

7577AAXF054

(16) Insert preassembled support shim into the piston.

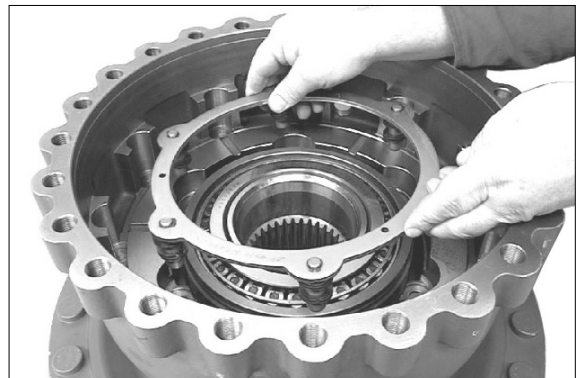

7577AAXF055

(17) Fix support shim by means of the circlip.

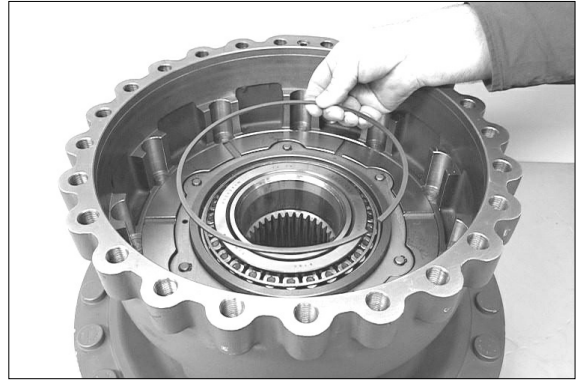

7577AAXF056

(18) Drive slotted pins (6EA) into the bores of the support shim to lock the circlip.

※ Special tool

Drive mandrel 5870 705 011

※ Pay attention to the installation position, see below sketch.



7577AAXF057

To the sketch :

1 Brake housing

2 Circlip

3 Slotted pin

4 Support shim

5 Piston

X Installation dimension $4.0_{-0,5}$ mm

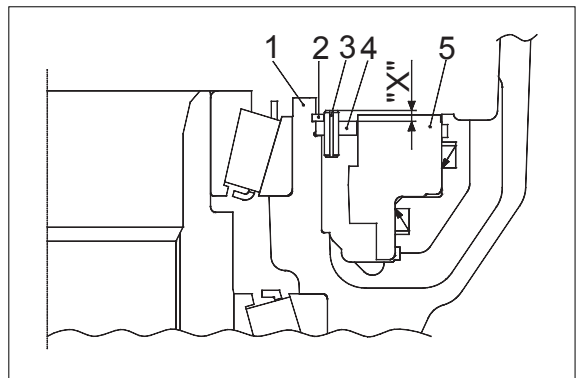

7577AAXF058

(19) Drive stop bolt into the planet carrier until contact.

Then wet spline (see arrow).

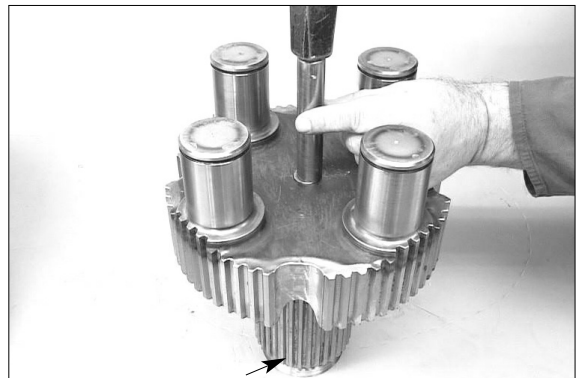

7577AAXF059

(20) Insert planet carrier into the spline of the output shaft until contact.

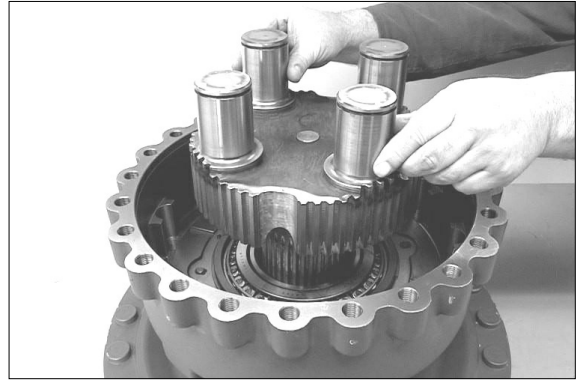

7577AAXF060

(21) Install outer- and inner clutch discs alternately starting with an outer clutch disc.

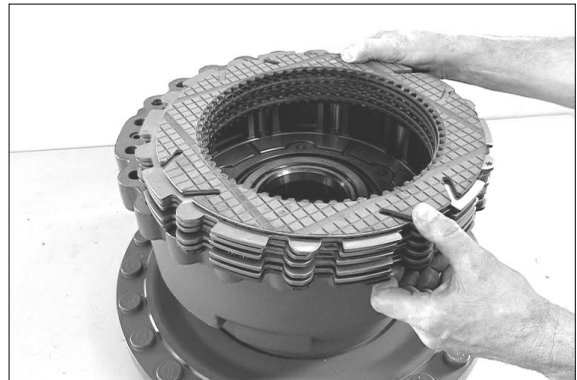

7577AAXF061

(22) Insert O-ring (see arrow) into the recess of the brake housing.

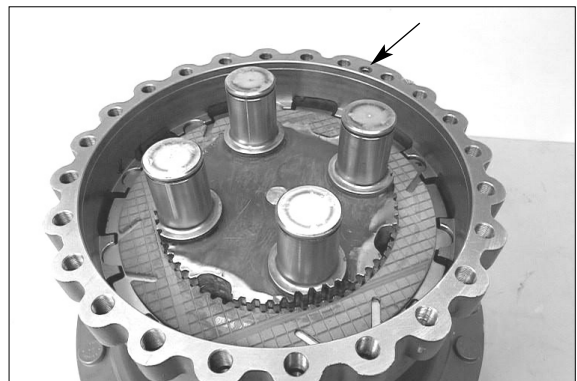

7577AAXF062

(23) Grease both O-rings (see arrows) and insert them into the annular grooves of the ring gear.

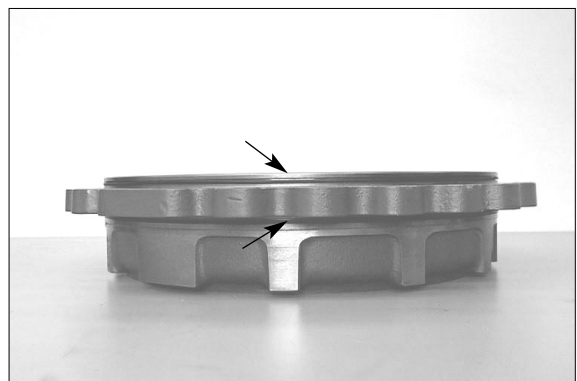

7577AAXF017

(24) Install two adjusting screws and insert ring gear into the brake housing until contact.

- ※ Special tool
Adjusting screws 5870 204 029
- ※ Pay attention to radial location.

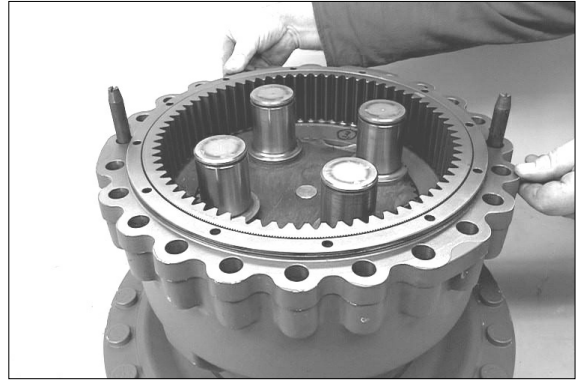

(25) Heat bearing inner rings and install them until contact with the big radius showing to the planet carrier (downwards).

- ※ Subsequently install bearing inner rings after cooling down.

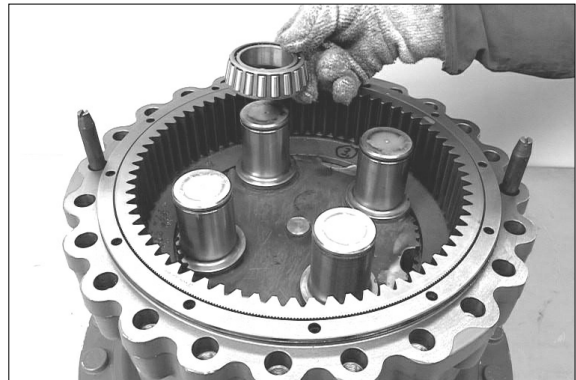

(26) Put planet gears onto the bearing inner rings.

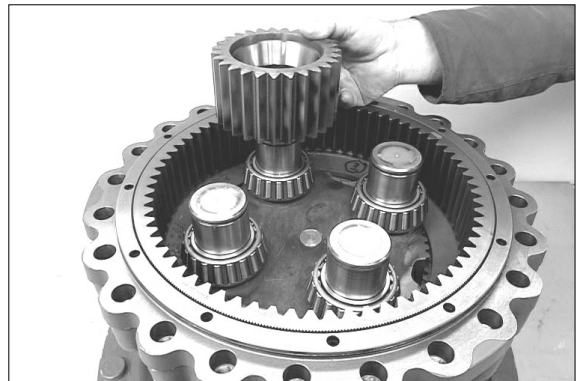

(27) Heat bearing inner rings and install them on the planet gears until contact.

- ※ Subsequently install bearing inner rings after cooling down.



(28) Fasten plant gears by means of retaining rings.

- ※ Special tool
Set of external pliers 5870 900 015

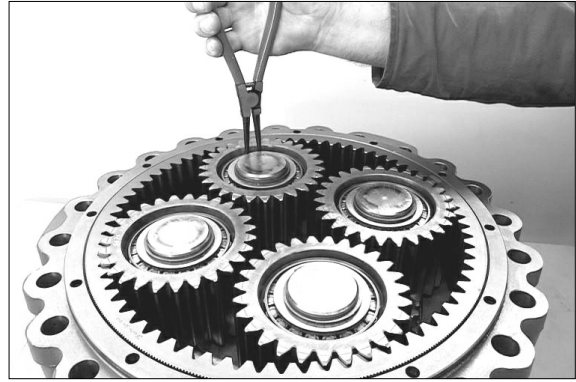

7577AAXF067

Adjust end play of sun gear shaft 0.5 ~ 2.0mm

(29) Fasten ring gear by means of cap screws until contact.

Then determine dimension I, from the mounting face of the ring gear up to the face of the stop bolt.

Dimension I e.g 46.20 mm

- ※ Special tool
Digital depth gauge 5870 200 072
Gauge blocks 5870 200 066
Straightedge 5870 200 022

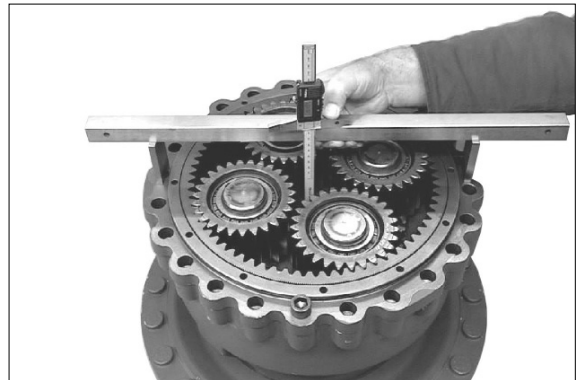

7577AAXF068

(30) Insert stub shaft into spline of the axle bevel gear until contact.

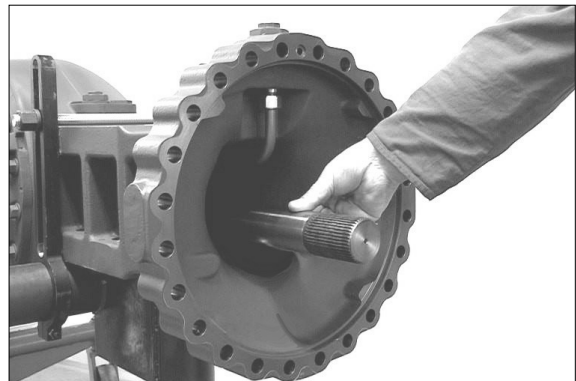

7577AAXF069

(31) Assemble sun gear shaft until contact.

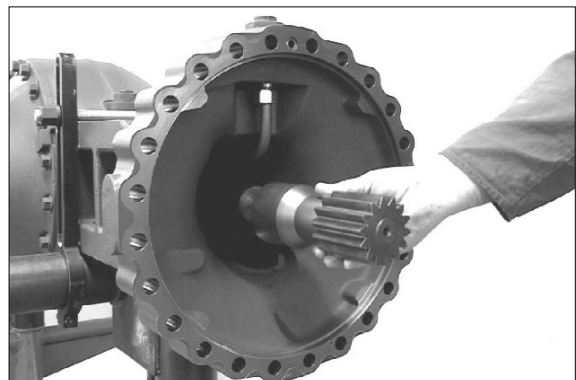

7577AAXF070

(32) Determine Dimension II from the face of the sun gear shaft up to the mounting face of the axle casing.

Dimension II e.g. 43.00mm

※ Special tool

Digital depth gauge 5870 200 072

Gauge blocks 5870 200 066

Straightedge 5870 200 022

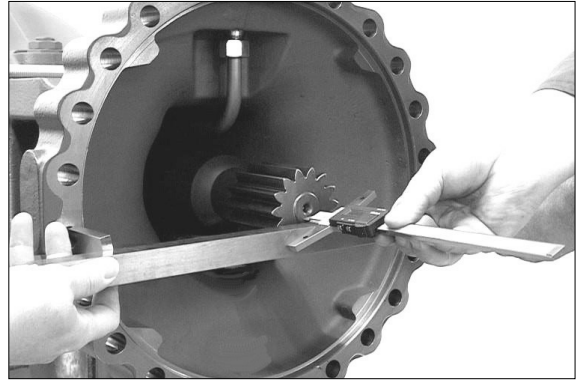

7577AAXF071

EXAMPLE A :

Dimension I 46.20mm

Dimension II - 43.00mm

Difference 3.20mm

required end play e.g. - 1.00mm

Difference = shim e.g. s = 2.20mm

(33) Insert sun gear shaft into the planet carrier.



7577AAXF072

(34) Fix determined shim(s), e.g. s = 2.20mm, into the sun gear shaft by means of grease.



7577AAXF073

(35) Fix O-ring(see arrow) into the recess of the axle casing by means of grease and install the preassembled output to the axle casing until contact by means of lifting tackle.

※ Special tool
Lifting bracket 5870 281 043

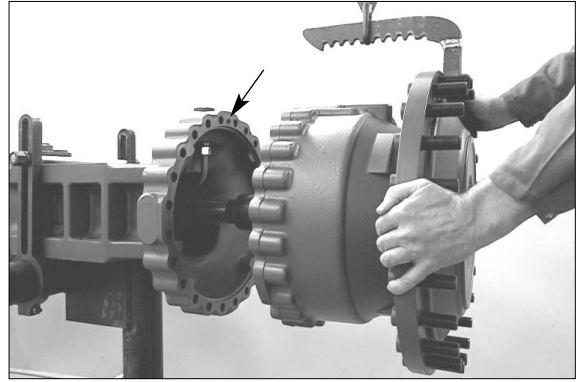

7577AAXF074

(36) Fasten output by means of hexagon screws and washers.

· Tightening torque (M18/10.9) :
39.8kgf · m(288lbf · ft)

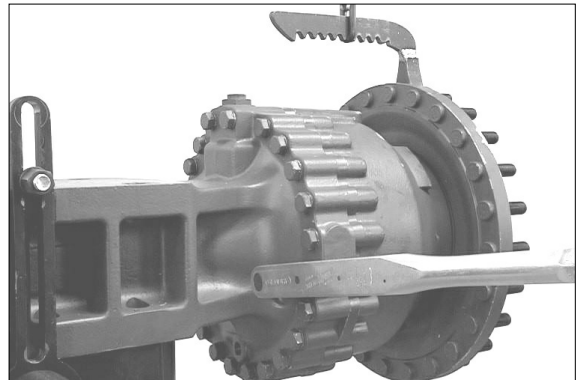

7577AAXF075

(37) Unscrew slotted nut by hand and then fasten it.

· Tightening torque : $71.4^{+30.6}$ kgf · m
(516^{+221} lbf · ft)

※ Special tool
Socket spanner 5870 656 077
Centering bracket 5870 912 028



7577AAXF076

(38) Secure slotted nut by means of slotted pin.

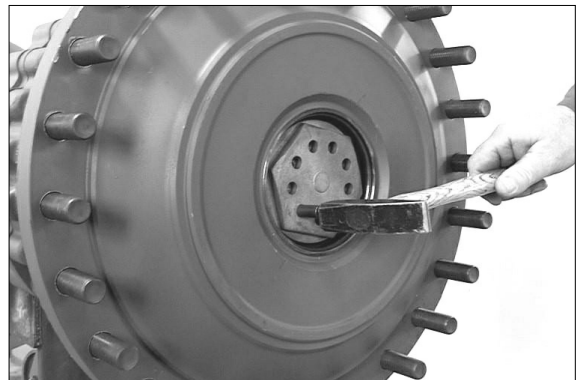

7577AAXF077

(39) Assemble O-ring (see arrow) to the cover.



7577AAXF078

(40) Insert cover into the output shaft until contact.

- ※ Special tool
Hammer (Plastic \varnothing 60) 5870 280 004



7577AAXF079

Leakage test of the brake hydraulics

- ※ Prior to start the test, ventilate the brake hydraulics completely.

- 1) Open the bleeder.
- 2) Slowly actuate the HP-pump until oil flows out of the bleeder.
- 3) Close the bleeder again.
- 4) Slowly pressurize the HP-pump with $p > 10$ bar and hold the pressure for some seconds.

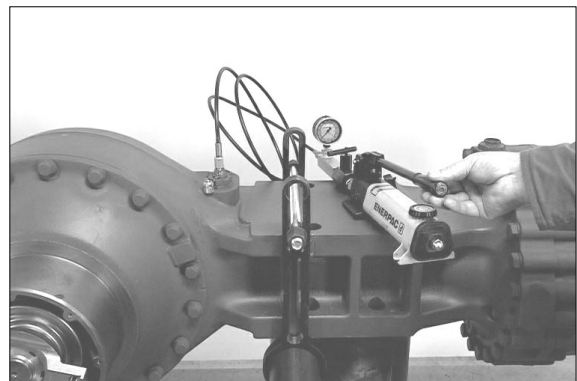

7577AAXF080

- ※ The brake piston extends and the cylinder chamber fills up with oil. The air accumulates in the upper section of the cylinder chamber.
- 5) Loosen the shut-off valve on the HP-pump.
 - ※ The reversing piston presses the air from the upper section of the cylinder into the brake line.
 - 6) Open the bleeder again.
 - 7) Slowly actuate the HP-pump until oil flows out of the bleeder.
- ※ Repeat procedure - Item 3)~7) until at 7) from the beginning of the actuation no more air exits from bleeder.
 - ※ Then pressurize the brake temporarily (5EA) with $p = 100$ bar max..

High-pressure test :

Increase test pressure up to $p = 100_{-10}$ bar and close connection to HP-pump by means of shut-off valve.

During a 5 min. testing time a pressure drop of max. 2% (2 bar) is allowed.

▲ If the maximum pressure of 100 bar is exceeded, there will be an excessive piston adjustment and a repeated disassembly of the brake or the adjusting is required to reset the gripping rings to the adjusting dimension.

Low-pressure test :

Reduce test pressure to $p = 5$ bar and close the shut-off valve again.

During a 5 min. testing time a pressure drop is not allowed.

※ Special tool

HP-Pump 5870 287 007

Mini-measuring hub 5870 950 115

(9/16"- 18UNF)

※ Prior to putting the axle into operation, fill in the oil acc. to the lubrication instructions.

3) DISASSEMBLY OF DIFFERENTIAL CARRIER AND BRAKE TUBES

(1) Disassembly of differential carrier

① Fasten axle on assembly truck.

※ Special tool

Assembly truck 5870 350 000

Holding fixtures 5870 350 077

Clamps 5870 350 075

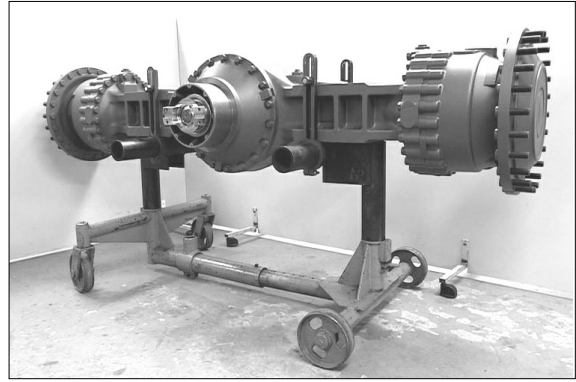

7577AAXF001

② Loosen screw plugs (3EA, see Figure 7577AAXF002 and 003) and drain oil from axle casing.

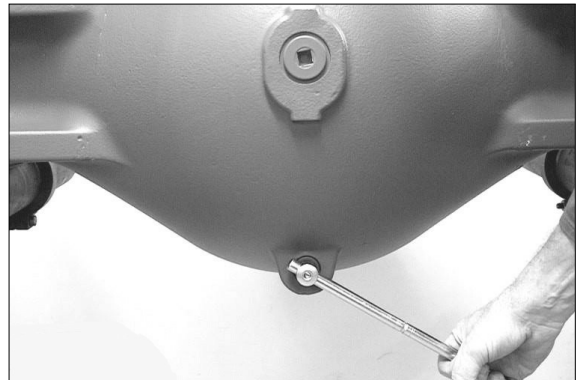

7577AAXF002

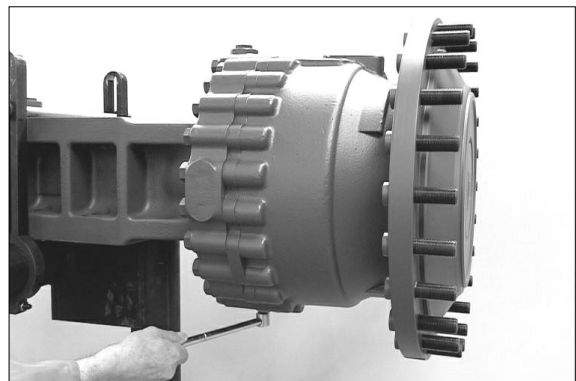

7577AAXF003

③ Secure output by means of lifting tackle and loosen hexagon screws.

※ Special tool

Lifting bracket 5870 281 043

※ Make step (Fig. 7577AAXF007~9) on both output sides.

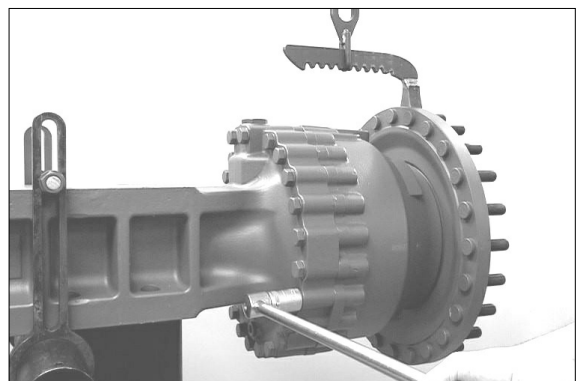

7577AAXF007

④ Separate complete output from the axle casing.

※ Pay attention to released O-ring(see arrow).

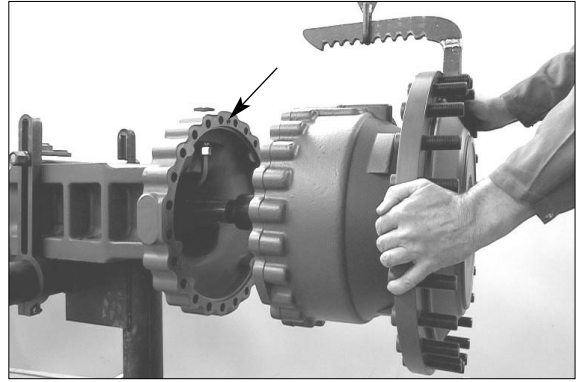

7577AAXF008

⑤ Pull stub shaft out of the sun gear shaft.

※ Pay attention to released shim(s).

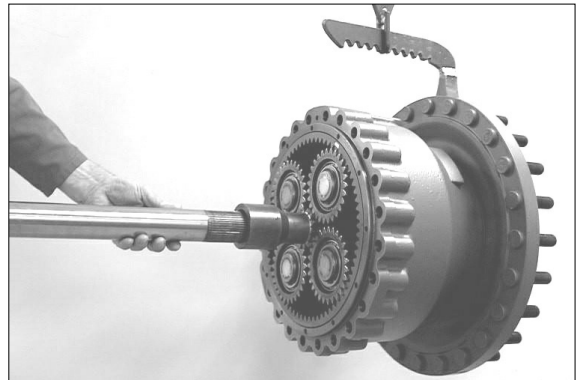

7577AAXF009

⑥ Loosen hexagon screws.

※ Mark location of differential carrier to the axle casing (see arrows).



7577AAXF081

⑦ Lift differential carrier by means of lifting tackle out of the axle casing.

※ Special tool
Lifting tackle

5870 281 044

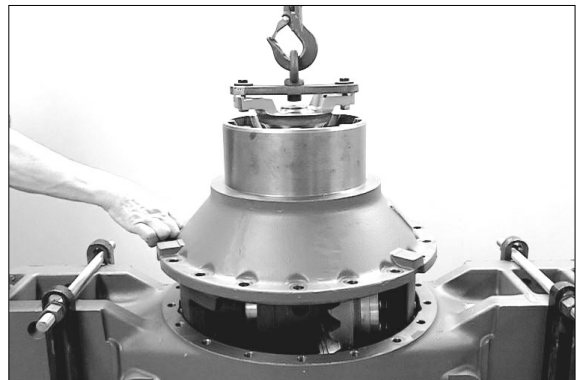

7577AAXF082

⑧ Fasten differential carrier to assembly truck.

※ Special tool

Assembly truck 5870 350 000

Holding fixture 5870 350 004

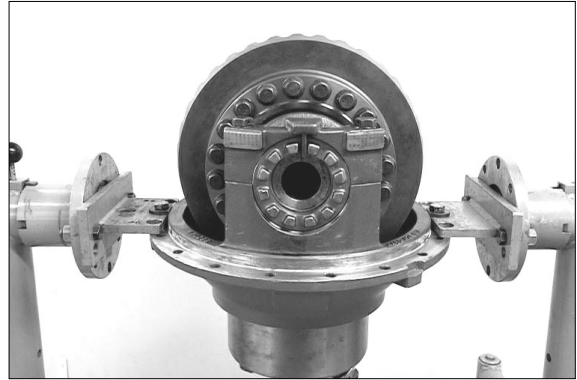

7577AAXF083

⑨ Drive out slotted pins.

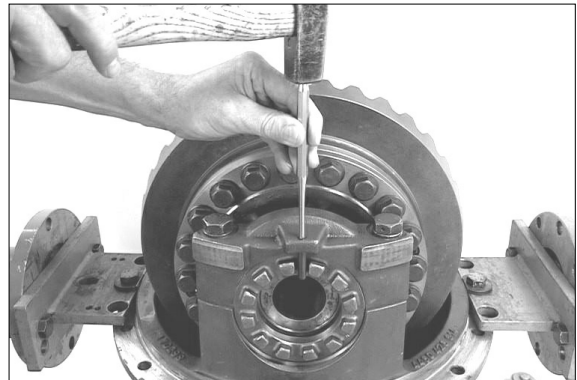

7577AAXF084

⑩ Loosen and remove both adjusting nuts.

※ Special tool

Socket spanner 5870 656 080

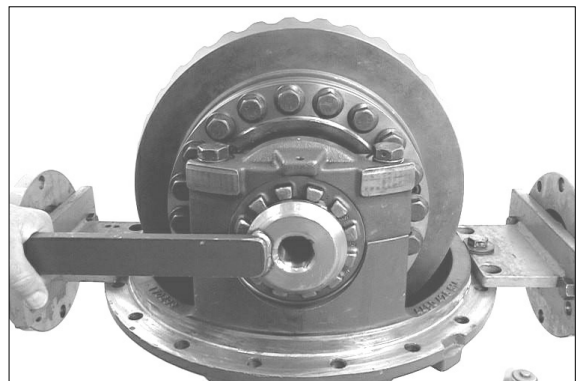

7577AAXF085

⑪ Heat axle drive housing by means of hot-air blower.

※ Special tool

Hot-air blower 230 V 5870 221 500

Hot-air blower 115 V 5870 221 501

※ Hexagon screws are installed with Loctite (Type No. 262).



7577AAXF086

⑫ Loosen hexagon screws and take off bearing bracket.

▲ Loosen hexagon screws by hand only.

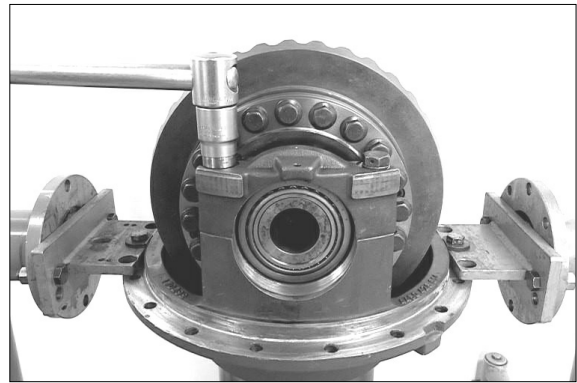

⑬ Remove both bearing outer rings.

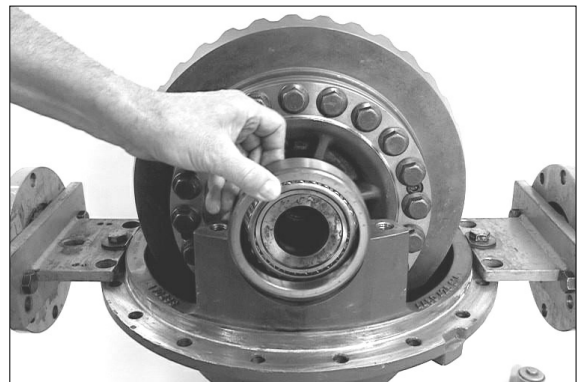

⑭ Lift differential out of the housing by means of lifting tackle.

※ Special tool
Lifting tackle 5870 281 013

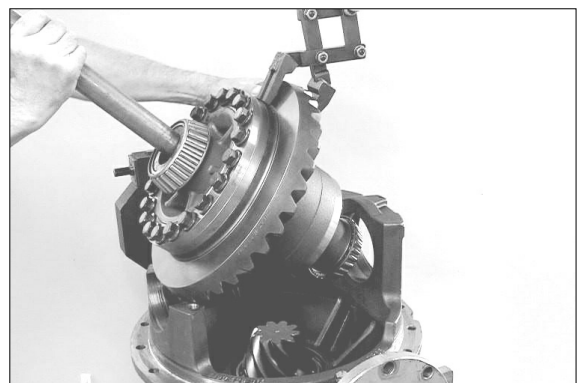

Disassembly of limited slip differential

⑮ Pull bearing inner ring from the differential housing.

※ Special tool
Gripping insert 5873 002 025
Basic set 5873 002 001



- ⑩ Pull bearing inner ring from the housing cover.

※ Special tool

Rapid grip

5873 012 012

Basic set

5873 002 001

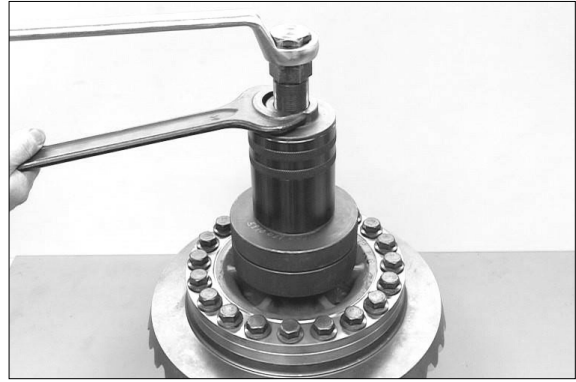

7577AAXF091

- ⑪ Fasten differential by means of press, loosen locking screws and remove released housing cover.

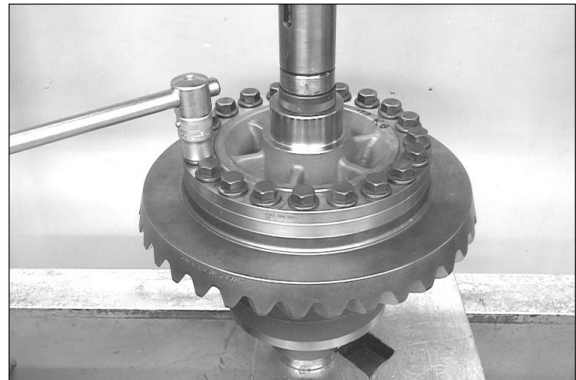

7577AAXF092

- ⑫ Remove all single parts from the differential housing.

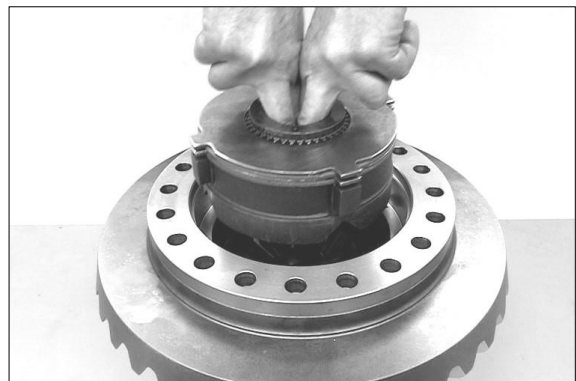

7577AAXF093

- ⑬ Press off crown wheel from the differential housing.

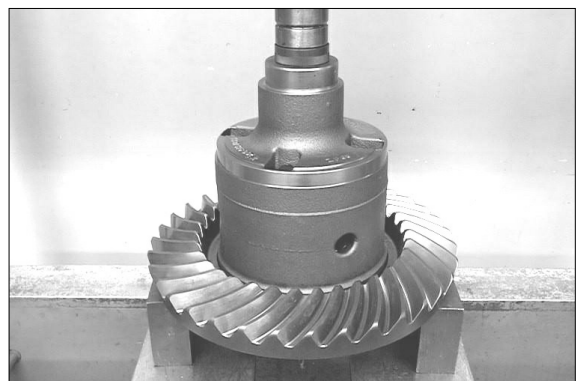

7577AAXF094

Disassembly of drive pinion

⑳ Heat hexagon nut by means of hot-air blower.

※ Special tool

Hot-air blower 230 V 5870 221 500

Hot-air blower 115 V 5870 221 501

※ Slotted nut is locked with Loctite (Type No. 262).

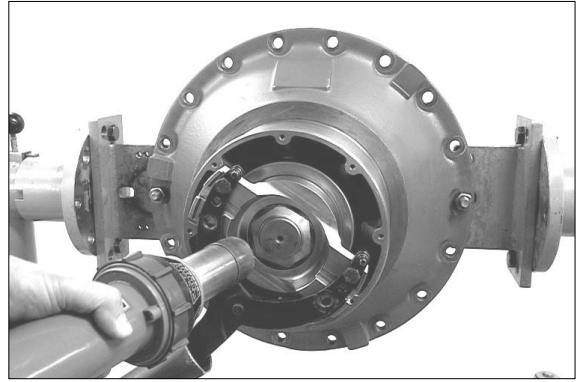

7577AAXF095

㉑ Loosen hexagon nut and remove the washer behind it.

※ Special tool

Fixture 5870 240 002

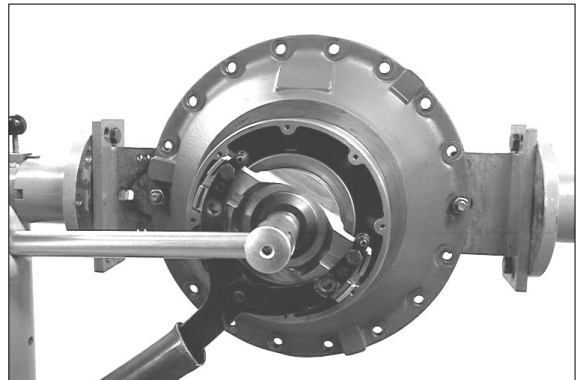

7577AAXF096

㉒ Pull input flange from the drive pinion.

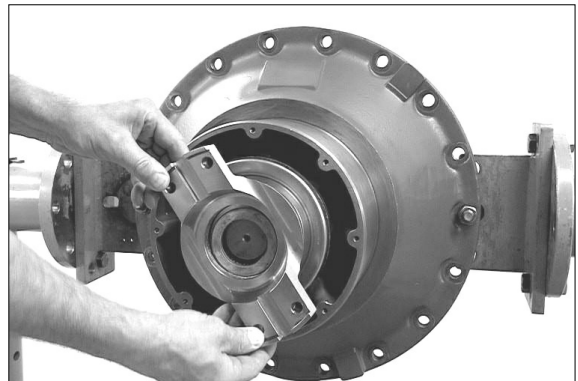

7577AAXF097

㉓ Press shaft seal out of the axle drive housing.

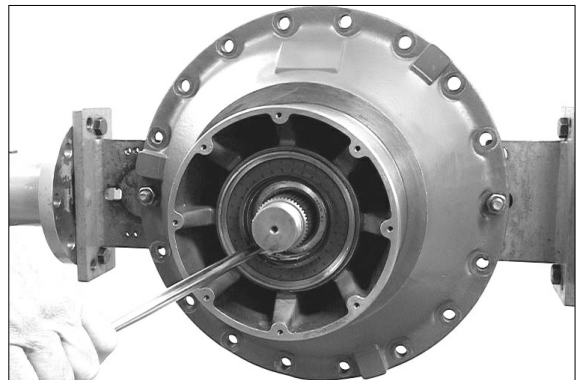

7577AAXF098

- ②④ Press drive pinion out of the axle drive housing by means of two-armed puller and remove the released bearing inner ring.

※ Special tool
Two-armed puller 5870 970 007

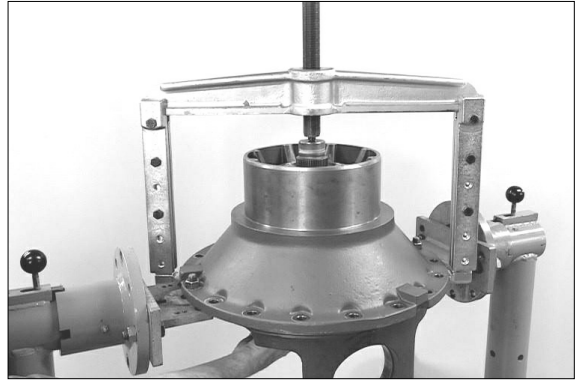

7577AAXF099

- ②⑤ Take off spacer ring and pull bearing inner ring from the drive pinion.

※ Special tool
Gripping insert 5873 002 032
Basic set 5873 002 001

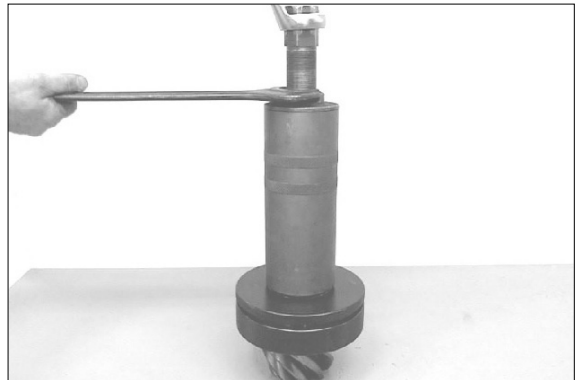

7577AAXF100

- ②⑥ If necessary drive out both bearing outer rings from the axle drive housing.

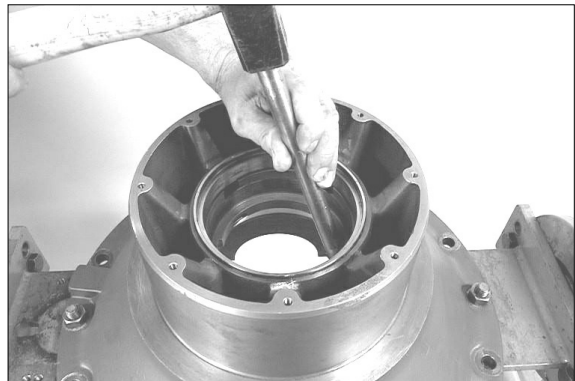

7577AAXF101

- ②⑦ Remove screw plug with vent valve from the axle casing.

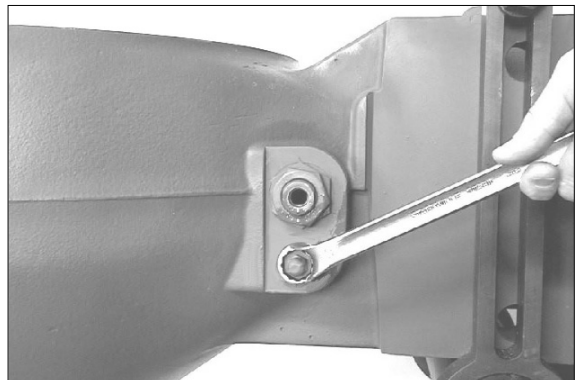

7577AAXF102

(2) Disassembly of brake tubes

① Loosen hexagon nut.

※ Step (Figure 7577AAXF103~107) to be made on both sides.

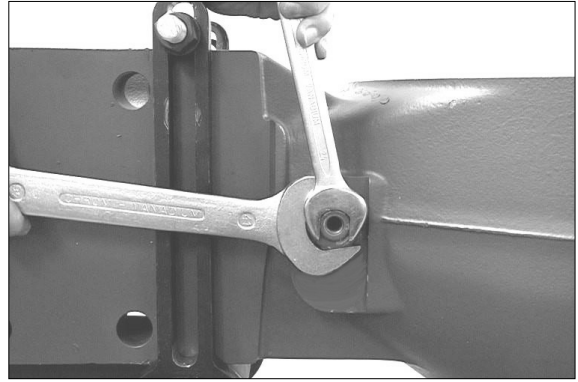

7577AAXF103

② Loosen union screw.

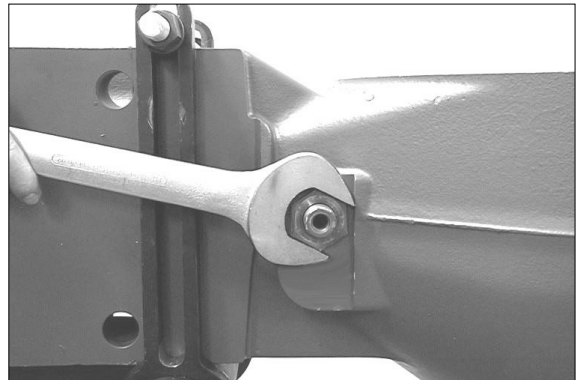

7577AAXF104

③ Loosen pipe union and remove released brake tube from the axle casing.

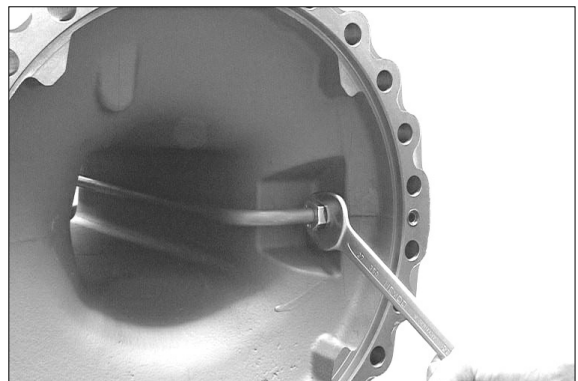

7577AAXF105

④ Remove vent valve from the connection part.

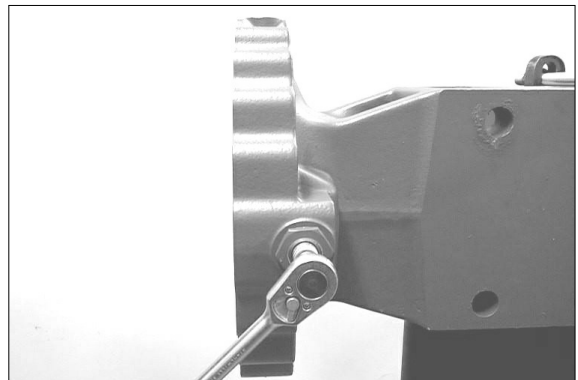

7577AAXF106

- ⑤ Loosen connection part and remove it from the axle casing.

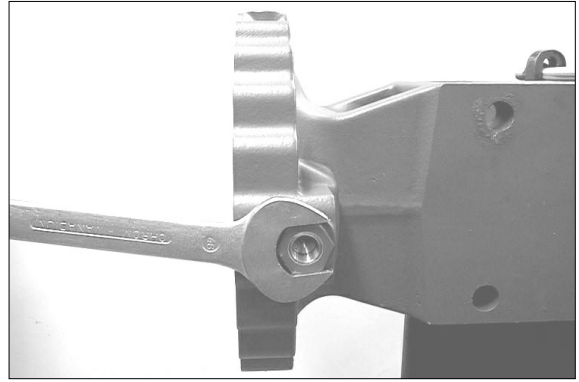

7577AAXF107

4) REASSEMBLY OF BRAKE TUBES AND DIFFERENTIAL CARRIER

(1) Reassembly of brake tubes

① Preassemble connection part as shown in opposite figure.

- 1 Vent valve
- 2 Connection part
- 3 O-Ring
- 4 Rectangular ring

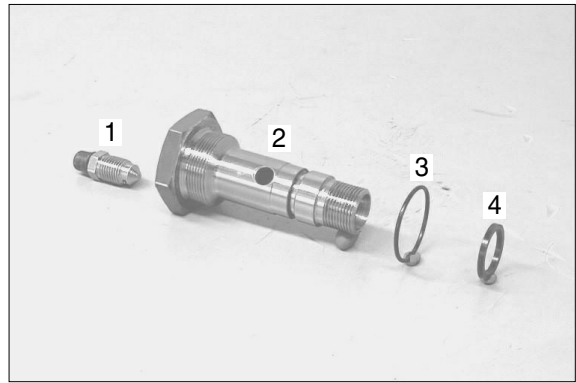

7577AAXF108

※ Step (Figure 7577AAXF108~114) is to be made on both output sides.

② Install connection part.

- Tightening torque : 13.3kgf · m
(95.9lbf · ft)

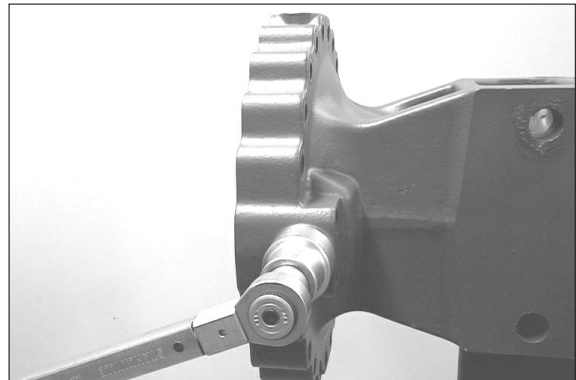

7577AAXF109

③ Provide union screw with new O-ring and install it.

- Tightening torque : 15.3kgf · m
(111lbf · ft)

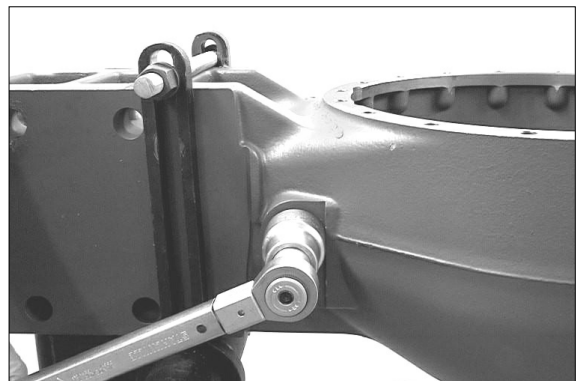

7577AAXF110

④ Insert O-ring (see arrow) into the annular groove of the brake tube.



7577AAXF111

- ⑤ Insert brake tube into the axle casing, assembling the connection part (see arrow 1) through the union screw (see arrow 2).

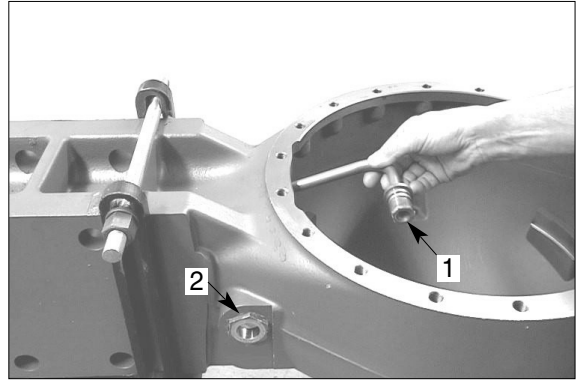

- ⑥ Fasten brake tube by means of hexagon nut and union nut (see below figure).

· Tightening torque : 10.2kgf · m
(73.8lbf · ft)

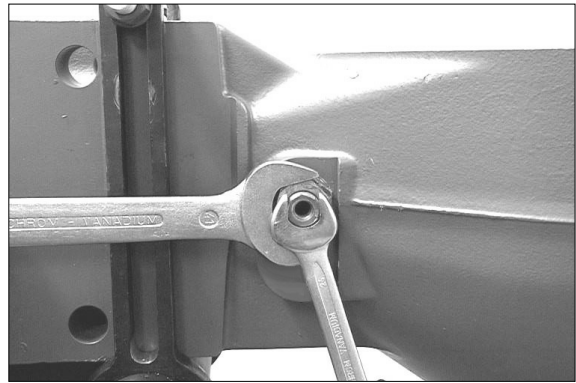

· Tightening torque : 8.2kgf · m
(59lbf · ft)

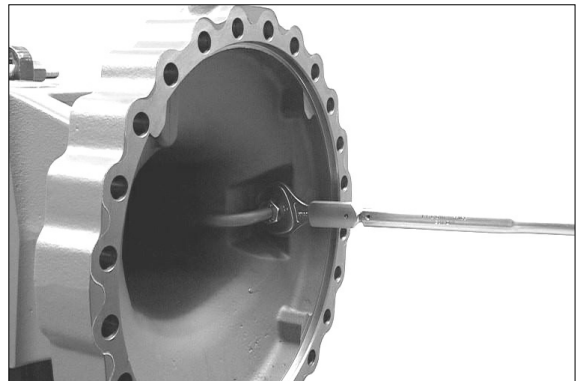

- ⑦ Preassemble screw plug as shown in opposite figure.

- 1 O-Ring
- 2 Screw plug
- 3 Vent valve

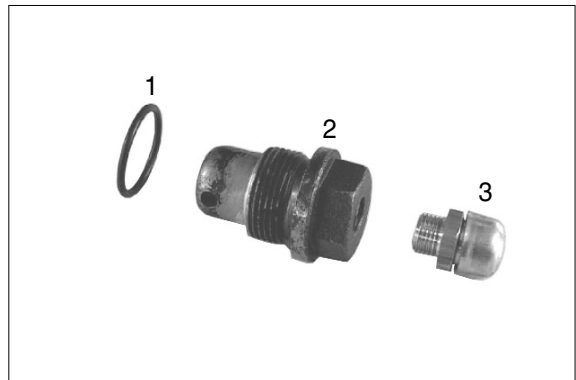

⑧ Install screw plug.

- Tightening torque : 7.1kgf · m
(51.6lbf · ft)

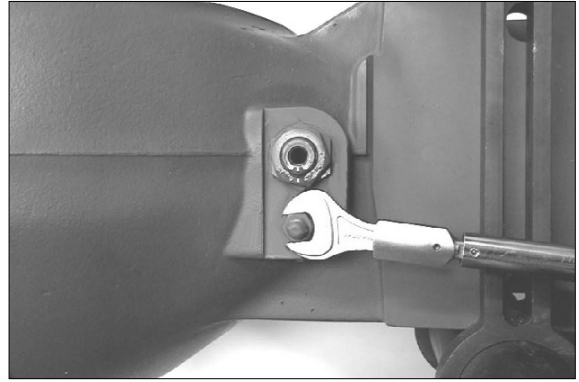

7577AAXF116

(2) Reassembly of differential carrier

- ※ If crown wheel or drive pinion are damaged, both parts have to be replaced together.

For new installation of a complete bevel gear set pay attention to the same pair number of drive pinion and crown wheel.

Determine shim thickness for a perfect tooth contact pattern

- ※ Make the following measuring steps at maximum accuracy.

Inexact measurements result in a faulty tooth contact pattern and require a repeated disassembly and reassembly of the drive pinion as well as of the differential.

- ① Install adapter pieces (1) and preliminarily fasten the bearing bracket by means of hexagon screws.

Then install stop washer (4) and measuring pin (3) and assemble measuring shaft (2) (see sketch).

- ※ Special tool

Adapter pieces	5870 500 044
Measuring shaft	5870 500 001
Measuring pin	5870 351 016
Stop washer	5870 351 027

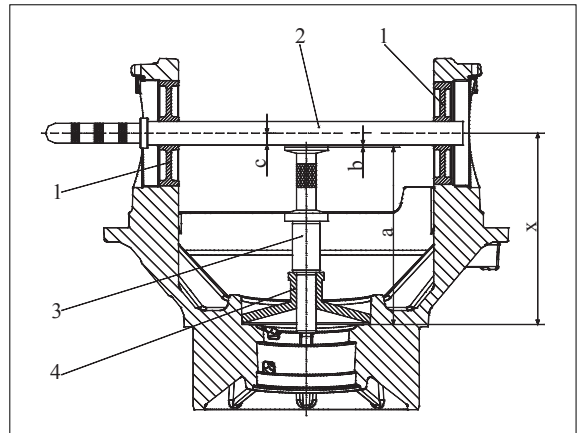

7577AAXF117

- ② Determine gap (dimension **b**) between measuring shaft and measuring pin by means of feeler gauge.

Dimension **b** e.g. 0.25mm

EXAMPLE A :

Dimension **a** (= Measuring pin + stop washer) 190.00mm

Dimension **b** + 0.25mm

Dimension **c** + 15.00mm

results in dimension X = 205.25mm

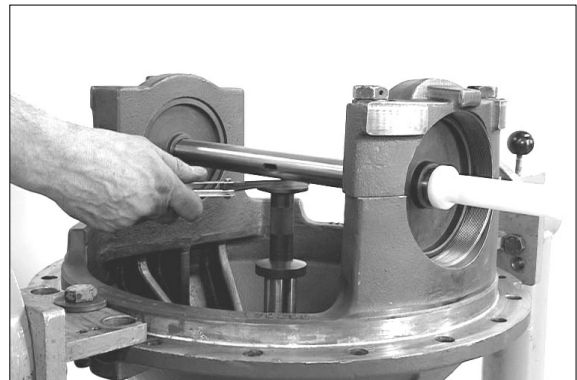

7577AAXF118

- ③ Determine dimension I (bearing width).

Dimension I e.g. 36.00mm

※ Special tool

Digital depth gauge 5870 200 072

Gauge blocks 5870 200 066

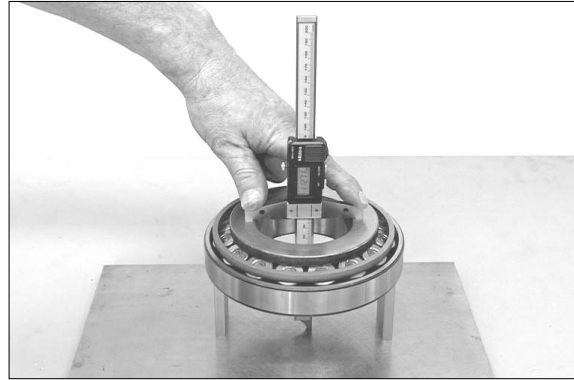

7577AAXF119

- ④ Read dimension II (dimension for pinion).

Dimension II e.g. 168.05mm

EXAMPLE B :

Dimension I 36.00mm

Dimension II + 181.05mm

results in dimension Y = 204.05mm

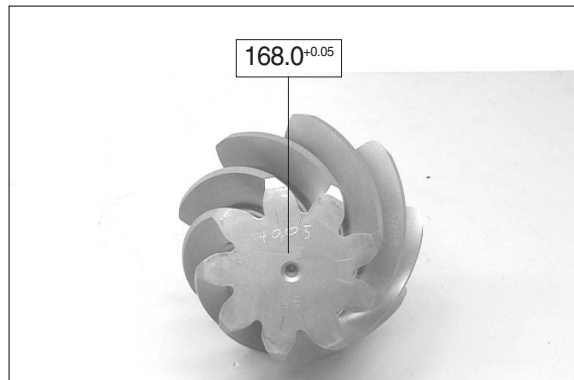

7577AAXF120

EXAMPLE C :

Dimension X 205.25mm

Dimension Y - 204.05mm

Difference = shim e.g. s = 1.20mm

Install the drive pinion

- ⑤ Place determined shim e.g. s = 1.20mm into the bearing bore.

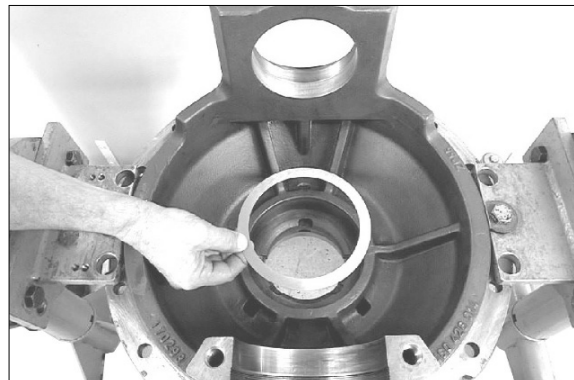

7577AAXF121

- ⑥ Undercool bearing outer ring and insert it into the bearing bore until contact.

※ Special tool

Driver 5870 058 060

Handle 5870 260 002

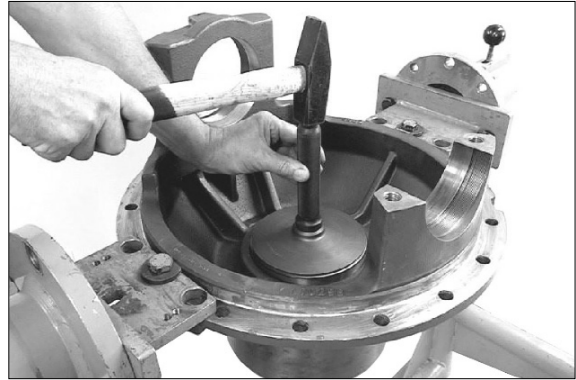

7577AAXF122

- ⑦ Undercool bearing outer ring on the input flange side and insert it until contact.

※ Special tool

Driver 5870 058 087

Handle 5870 260 002



7577AAXF123

- ⑧ Press bearing inner ring on the drive pinion until contact.

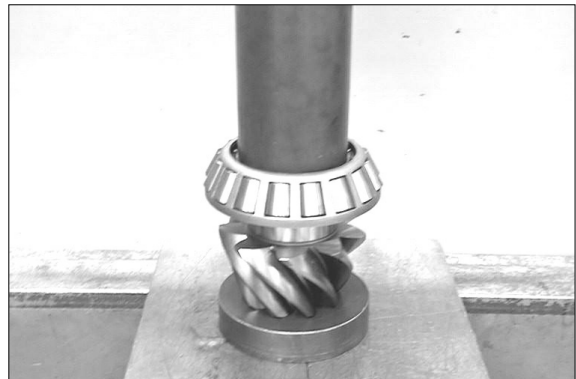

7577AAXF124

Adjust rolling moment of drive pinion bearing 0.15 ~ 0.31kgf · m (Figure 7577AAXF125~133) :

- ⑨ Assemble spacer ring (e.g. s = 8.70mm).

※ As per experience the required rolling moment is obtained by use of the spacer ring (e.g. s = 8.70mm) available at disassembly.

However, a later checking of the rolling moment is imperative.

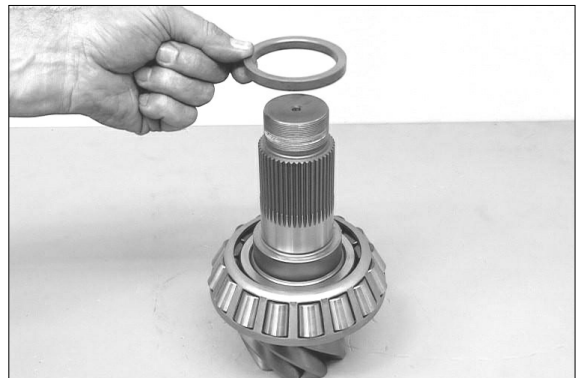

7577AAXF125

- ⑩ Insert preassembled drive pinion into the axle drive housing and assemble the heated bearing inner ring until contact.

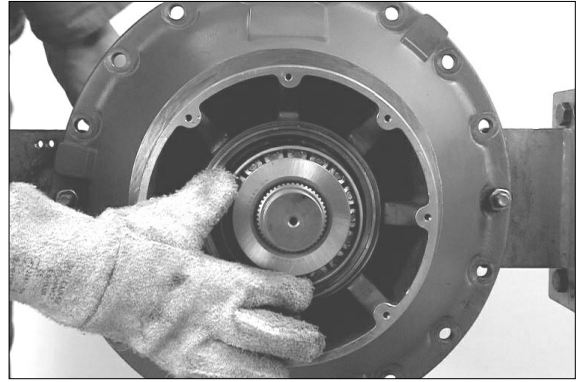

7577AAXF126

- ⑪ Press dust protection on the input flange until contact.

※ Special tool

Driver

5870 056 012

Handle

5870 260 002

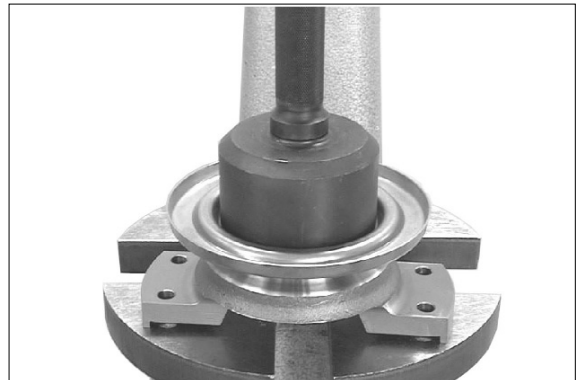

7577AAXF127

- ⑫ Assemble input flange.

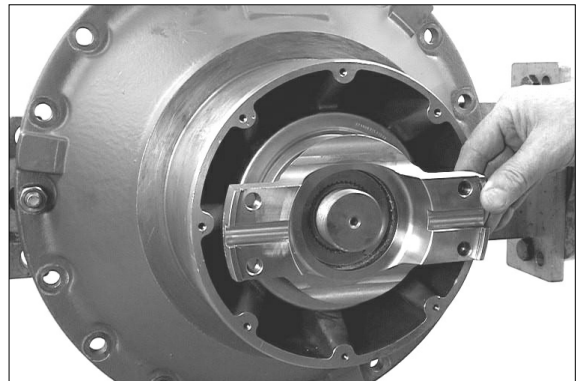

7577AAXF128

- ⑬ Assemble washer.

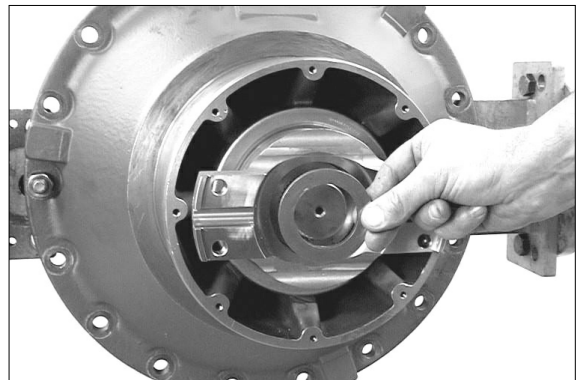

7577AAXF129

- ⑭ Unscrew hexagon nut by hand and tighten it.

· Tightening torque : 71.4kgf · m
(516lbf · ft)

※ Special tool

Fixture 5870 240 002

※ When tightening rotate drive pinion in both directions several times.

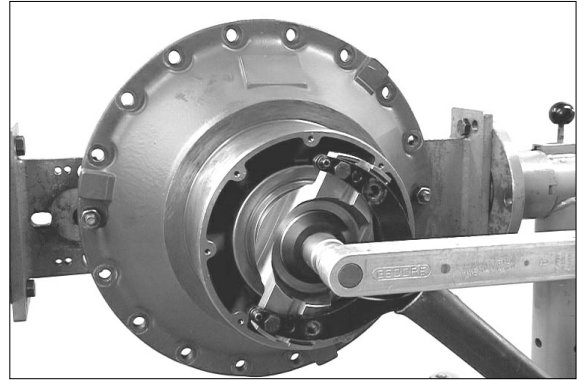

7577AAXF130

- ⑮ Check rolling moment (0.15~0.31kgf · m).

※ For new bearings it should be tried to achieve the max. value of the rolling moment.

▲ If the required rolling moment is not obtained, correct it with an adequate spacer ring (Figure 7577AAXF125), according to the following indications :

Rolling moment too low - install a thinner spacer ring

Rolling moment too high - install a thicker spacer ring.

- ⑯ Then loosen the hexagon nut again and pull input flange from the drive pinion.

Install shaft seal with the sealing lip showing to the oil chamber (downwards).

※ Special tool

Driver 5870 048 225

※ The exact installation position of the shaft seal will be obtained by using the exact driver.

▲ Just before the installation wet the outer diameter of the shaft seal with spirit and fill the space between sealing and dust lip with grease.

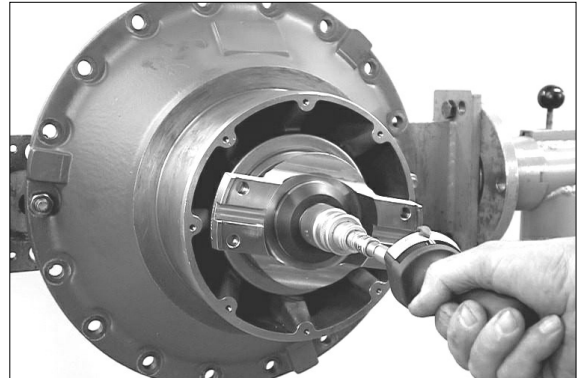

7577AAXF131



7577AAXF132

- ⑰ Assemble input flange and finally fasten it by means of washer and hexagon nut.

· Tightening torque : 71.4kgf · m(516lbf · ft)

※ Special tool

Fixture 5870 240 002

▲ Apply Loctite (Type No. 262) onto the thread of the hexagon nut.

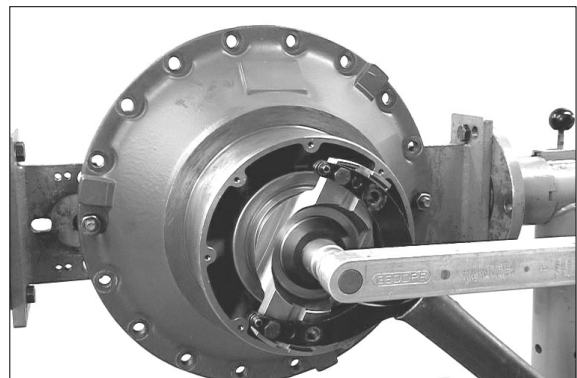

7577AAXF133

Reassembly of limited slip differential

- ⑱ Place both thrust washers into the differential housing.
- ※ Prior to installation all single parts of the differential must be oiled.

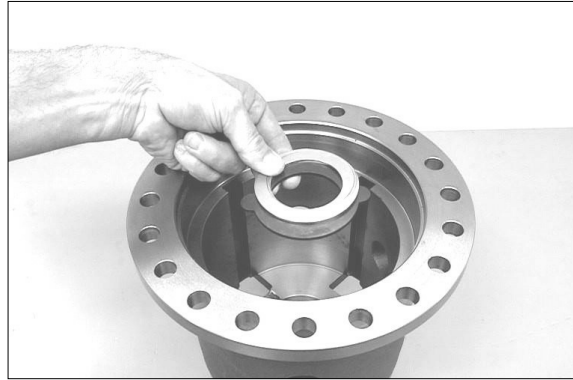

- ⑲ Starting with an outer clutch disc install alternately the outer and inner clutch discs.
- ⚠ Thickness of the disc pack must be identical on both sides.

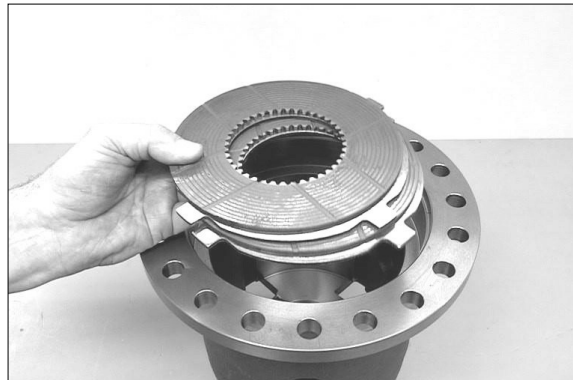

- ⑳ Put on the pressure ring.

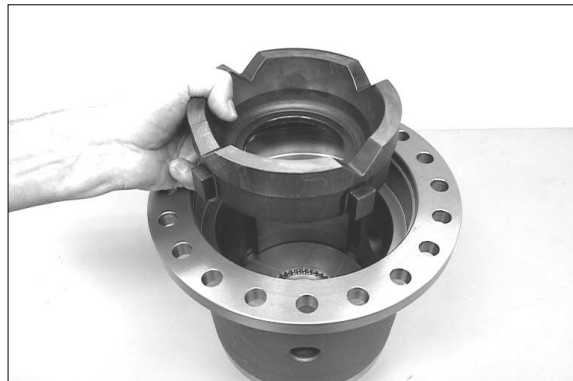

- ㉑ Insert axle bevel gear until contact and at the same time assemble all inner clutch discs with the spline.

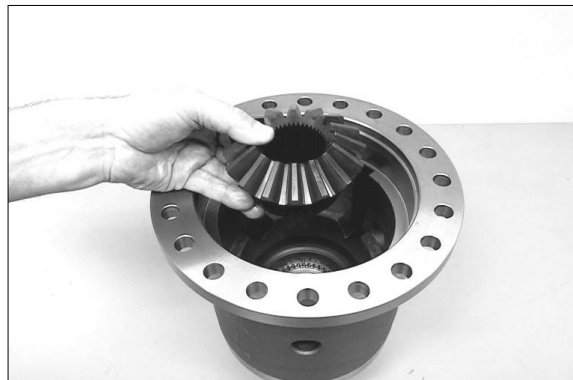

- ② Preassemble differential spider and insert it into the differential housing.

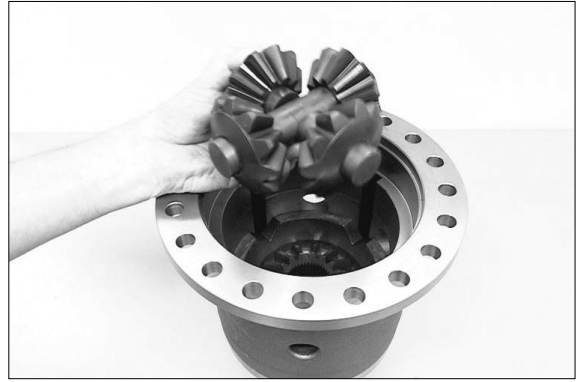

7577AAXF138

- ③ Put on the second axle bevel gear.



7577AAXF139

- ④ Insert the second pressure ring into the differential housing.



7577AAXF140

- ⑤ Starting with an inner clutch disc install alternately the inner and outer clutch discs.

- ▲ Thickness of the clutch disc pack must be identical on both sides.

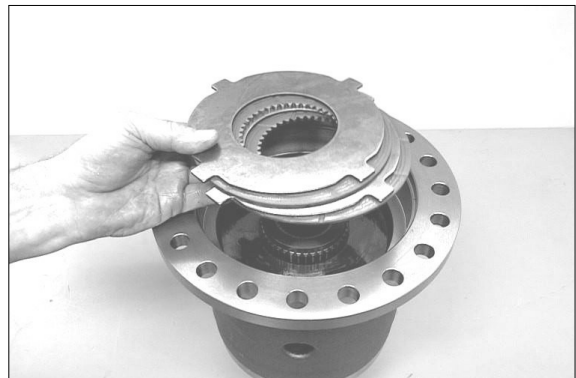

7577AAXF141

Determine disc clearance 0.2~0.8mm

- ②⑥ Determine dimension I, from mounting face of the differential housing to plane face of the outer clutch disc.

Dimension I e.g 38.05mm

※ Special tool
Digital depth gauge 5870 200 072

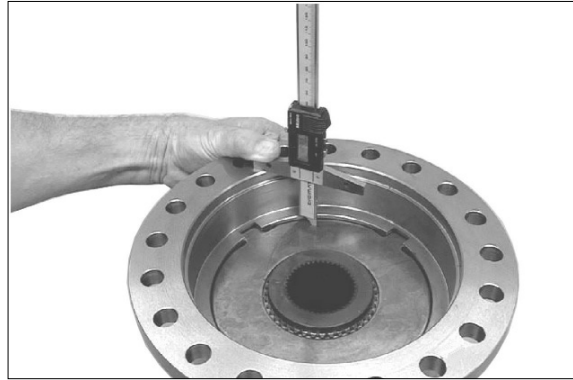

7577AAXF142

- ②⑦ Determine dimension II, from contact surface of the outer clutch disc to the mounting face of the housing cover.

Dimension II e.g 37.75mm

EXAMPLE D :

Dimension I 38.05mm

Dimension II - 37.75mm

Difference = Disc clearance = 0.30mm

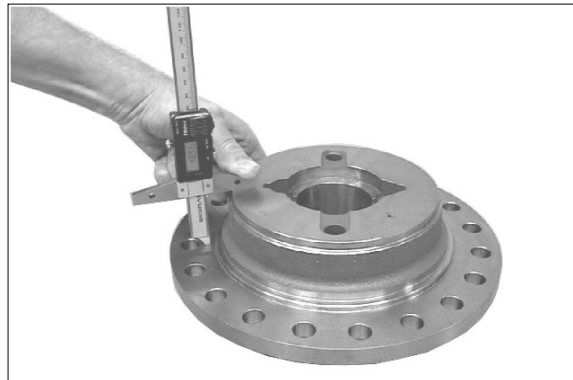

7577AAXF143

※ If the required disc clearance is not obtained, correct it with the adequate outer clutch discs (s = 2.9, s = 3.0, or s = 3.3 mm), taking care that the difference in thickness between the left and the right disc pack must only be 0.01 at a maximum.

- ②⑧ Fix both thrust washers with grease into the recess of the housing cover.



7577AAXF144

⑳ Put on the housing cover.

Then heat crown wheel and install it until contact.

※ Special tool
Adjusting screws 5870 204 040

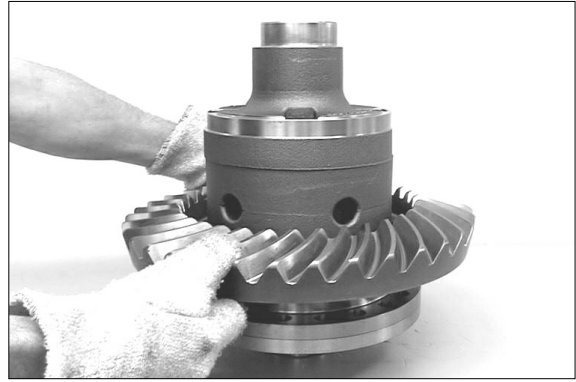

7577AAXF145

㉑ Fix differential by means of press and fasten crown wheel by means of new locking screws.

· Tightening torque : 41.8kgf · m
(302lb · ft)

▲ Only use of new locking screws is permissible.

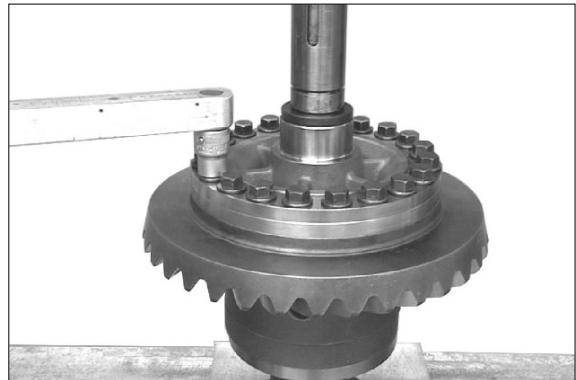

7577AAXF146

㉒ Press on both bearing outer rings until contact.



7577AAXF147

㉓ Insert differential into the axle drive housing by means of lifting tackle.

※ Special tool
Lifting tackle 5870 281 013

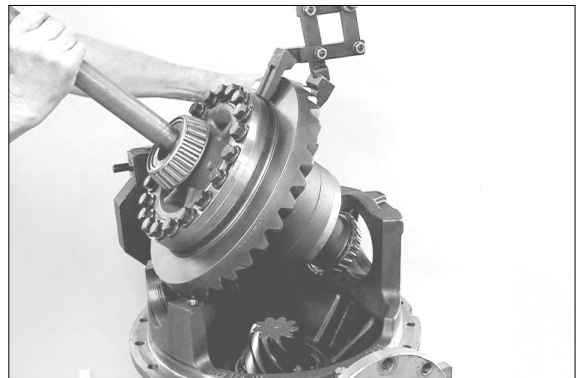

7577AAXF148

- ③ Place bearing outer ring into the axle drive housing.

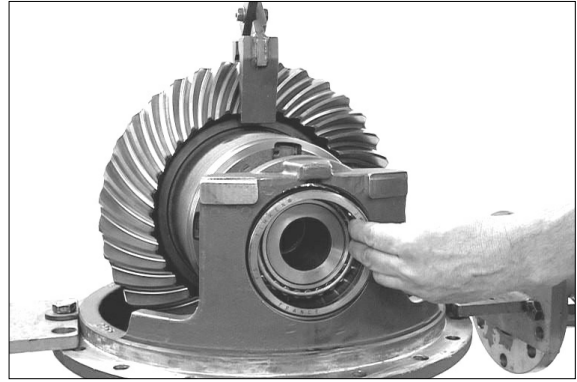

- ④ Preliminarily fix the bearing outer ring by means of adjusting nut.

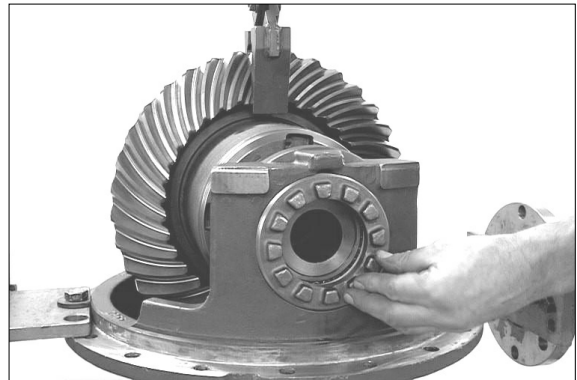

- ⑤ Install crown wheel-sided bearing outer ring.



- ⑥ Preliminarily fix the crown wheel-sided bearing outer ring by means of the second adjusting nut.

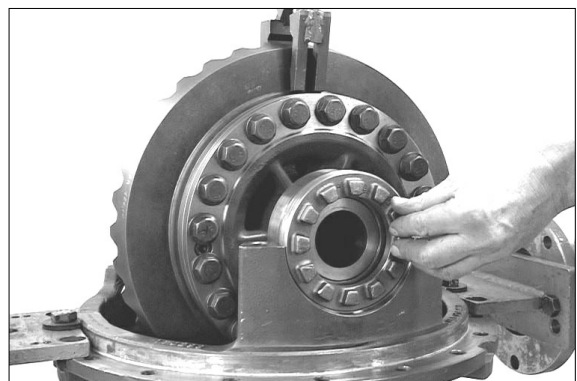

- ③⑦ Put on bearing bracket and fasten it by means of hexagon screws and washers.

- Tightening torque (M16/10.9) :
28.6kgf · m(207lbf · ft)

- ※ Pay attention to clearance of the adjusting nut.

▲ Apply Loctite (Type No. 262) onto threads of the hexagon screws.

Adjustment of backlash and bearing preload

- ③⑧ Place dial indicator right-angled at the outer diameter of the tooth flank (crown wheel).

Then install both adjusting nuts only to such an extent that the required backlash - see the value etched on the outer diameter of the crown wheel - is reached.

- ※ Special tool
Magnetic stand 5870 200 055
Dial indicator 5870 200 057

- ※ At this step rotate the differential several times.

- ③⑨ Determine bracket width and correct it on both adjusting nuts, if required.

Bracket width 367.90 ^{+0.05} mm

- ※ Special tool
Caliper gauge 5870 200 058

Then check backlash once again.

- ※ Adjusting of the bracket width results in the required bearing preload.

- ④⑩ Cover some tooth flanks of the crown wheel with marking ink and roll crown wheel in both directions over the drive pinion.

Compare the obtained tooth contact pattern with the examples.

▲ If the tooth contact pattern differs, there has been a measuring error at determination of the shim (Figure 7577AAXF121/page 3-266), what is imperative to be corrected.

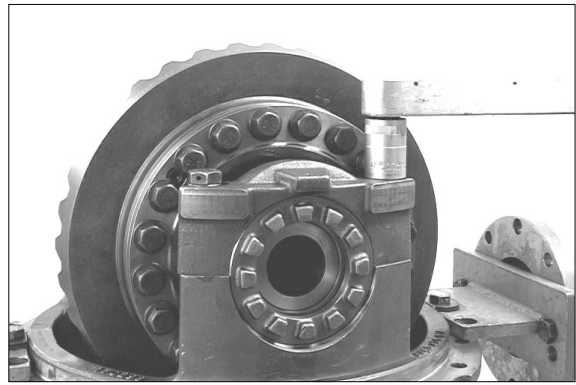

7577AAXF153

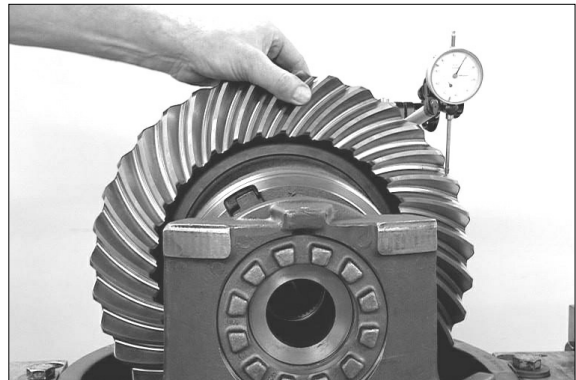

7577AAXF154

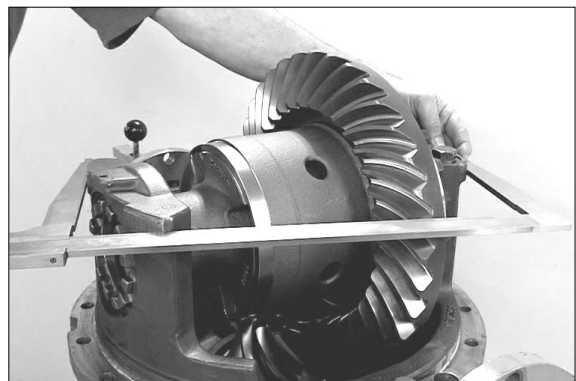

7577AAXF155

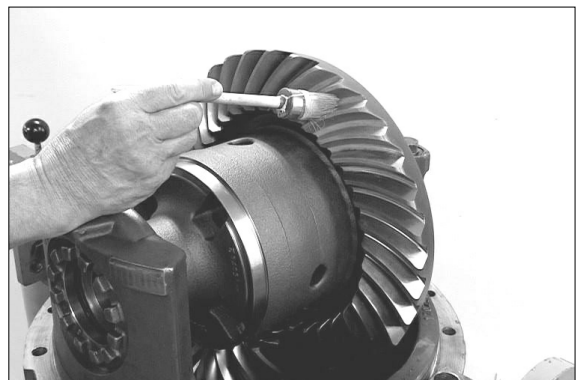

7577AAXF156

- ④① Secure both adjusting nuts by means of slotted pins.

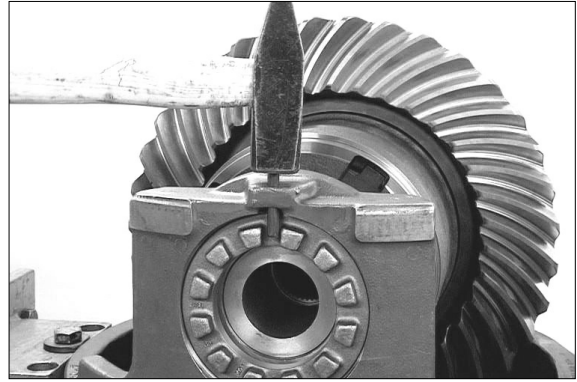

7577AAXF157

- ④② Install two adjusting screws and insert differential carrier into the axle casing until contact by means of lifting tackle.

※ Special tool

Adjusting screws 5870 204 022

Lifting tackle 5870 281 044

※ Observe radial location (see marking Page 3-254 / Figure 7577AAXF081).

- ▲ Apply sealing compound (Three Bond Type 1215) on mounting face.

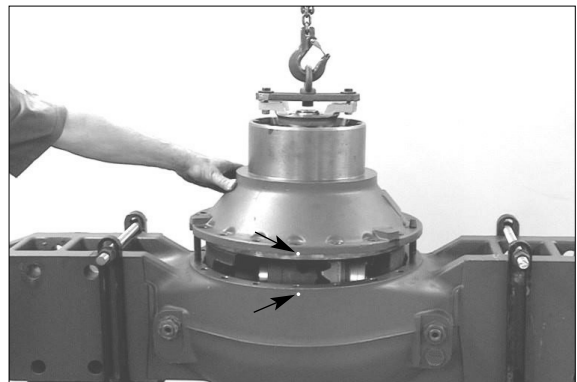

7577AAXF158

- ④③ Fasten differential carrier by means of **new** locking screws.

· Tightening torque : 25.5kgf · m
(184lbf · ft)

- ▲ Only use of the new locking screws is permissible.

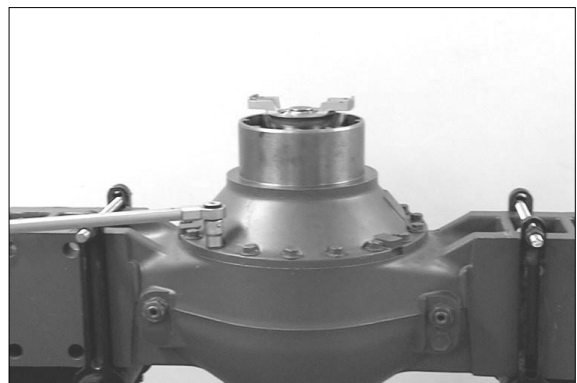

7577AAXF159

- ④④ Insert stub shaft into spline of the axle bevel gear until contact.

Then fix O-ring (see arrow) by means of grease into the recess of the axle casing.

※ Step (Figure 7577AAXF160 ~ 163) is to be made on both output sides.

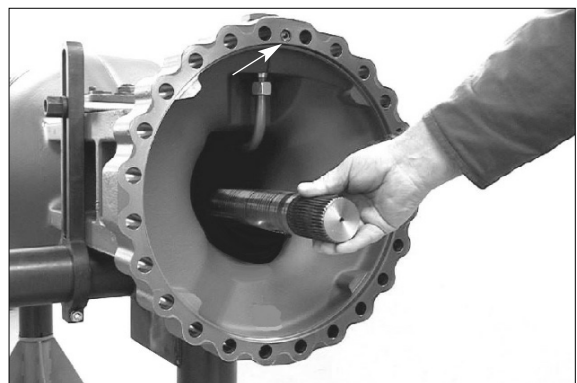

7577AAXF160

- ④⑤ Thrust washer(s) removed at disassembly have to be fixed in the sun gear shaft by means of grease.



7577AAXF161

- ④⑥ Place complete output by means of lifting tackle to the axle casing until contact.

- ※ Special tool
Lifting bracket 5870 281 043

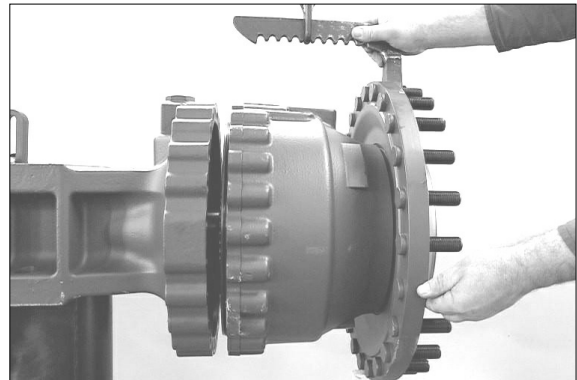

7577AAXF162

- ④⑦ Fasten output by means of hexagon screws and washers.

- Tightening torque (M18/10.9) :
39.8kgf · m(288lbf · ft)

- ※ Prior to putting into operation of the axle, fill oil in accordance with lubrication instructions.

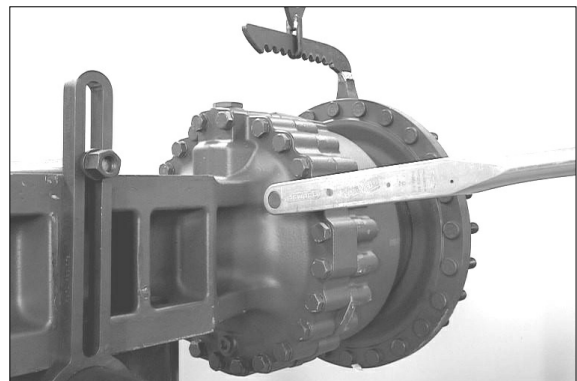

7577AAXF163