

SECTION 7 ELECTRICAL SYSTEM

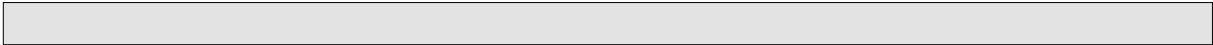

- Group 1 Component Location ----- 7-1
- Group 2 Electrical Circuit ----- 7-3
- Group 3 Monitoring System ----- 7-22
- Group 4 Electrical Component Specification ----- 7-38
- Group 5 Connectors ----- 7-45
- Group 6 Troubleshooting ----- 7-59

SECTION 7 ELECTRICAL SYSTEM

GROUP 1 COMPONENT LOCATION

1. LOCATION 1

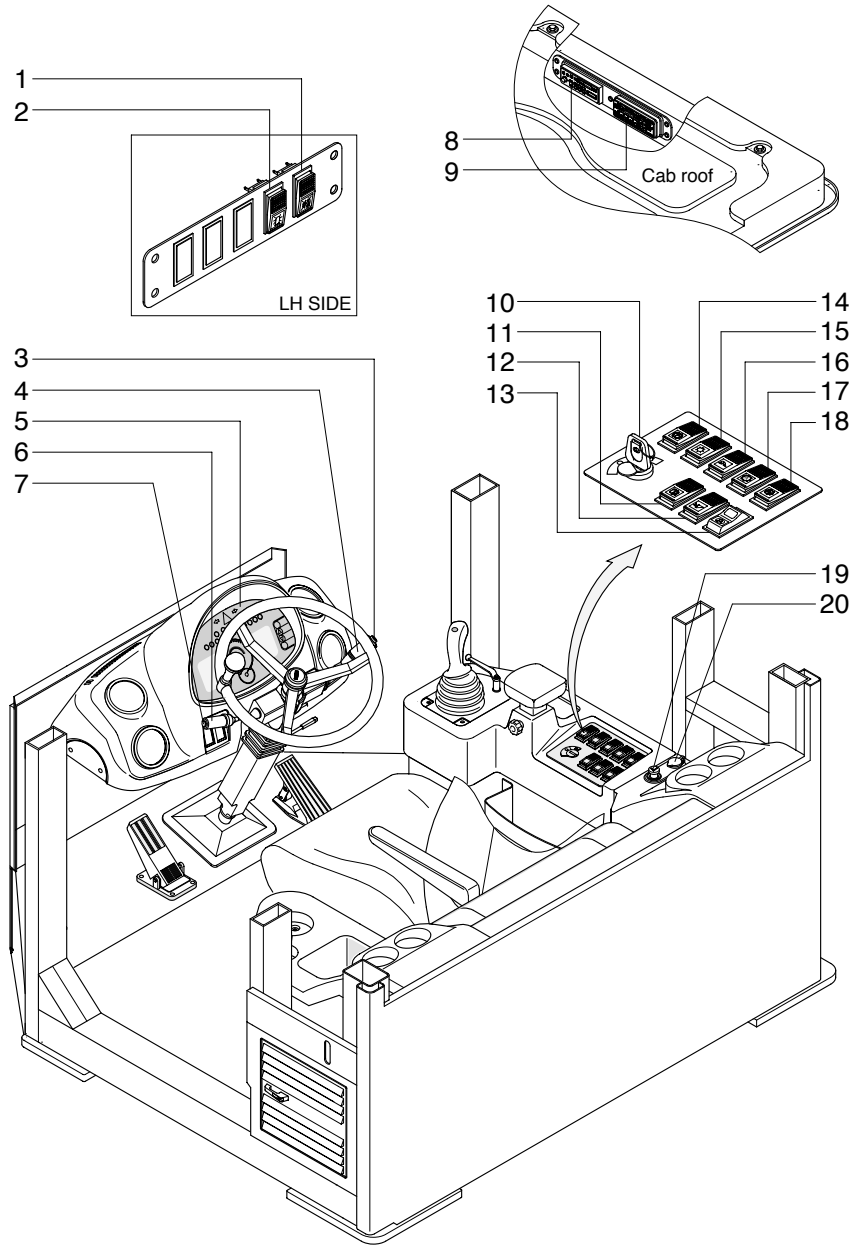

7707EL02

- | | | |
|-------------------------|--------------------------------|--------------------------|
| 1 Buzzer stop switch | 8 Radio & cassette | 15 Main light switch |
| 2 Beacon switch(option) | 9 Aircon & heater switch | 16 Work lamp switch |
| 3 Horn button | 10 Starting switch | 17 Auto select switch |
| 4 Multi function switch | 11 Rear wiper/washer switch | 18 Clutch cut off switch |
| 5 Cluster | 12 Ride control switch(option) | 19 Cigar lighter |
| 6 Gear selector lever | 13 Pump motor switch(option) | 20 12V socket |
| 7 Kick down switch | 14 Parking brake switch | |

2. LOCATION 2

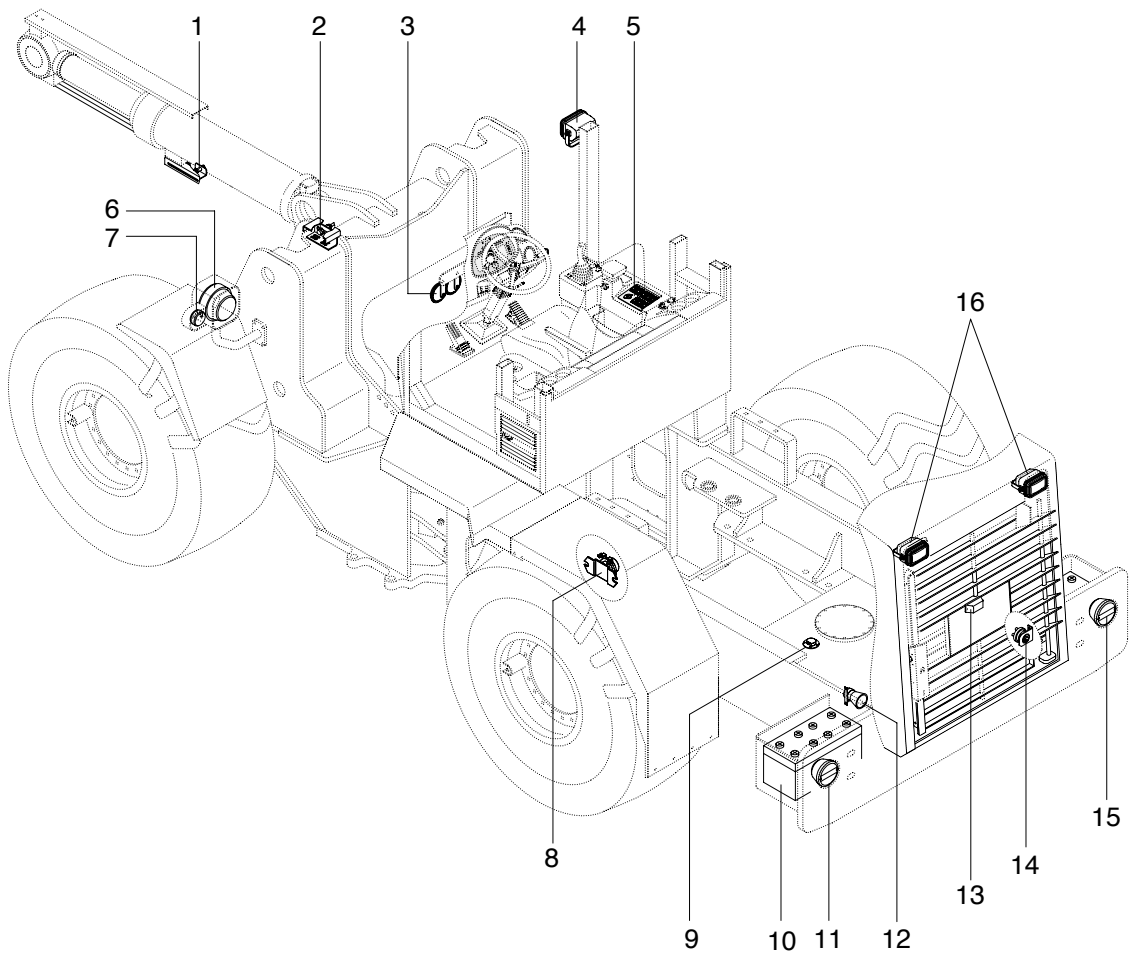

7707EL02-1

- | | | | | | |
|---|------------------|----|-----------------|----|-------------------|
| 1 | Proximity switch | 7 | Front turn lamp | 12 | Back up buzzer |
| 2 | Proximity switch | 8 | Start relay | 13 | Number plate lamp |
| 3 | Horn | 9 | Fuel sender | 14 | Master switch |
| 4 | Work lamp | 10 | Battery | 15 | Rear combi lamp |
| 5 | Switch panel | 11 | Rear combi lamp | 16 | Work lamp |
| 6 | Head lamp | | | | |

1. ILLUMINATION CIRCUIT

1) OPERATING FLOW

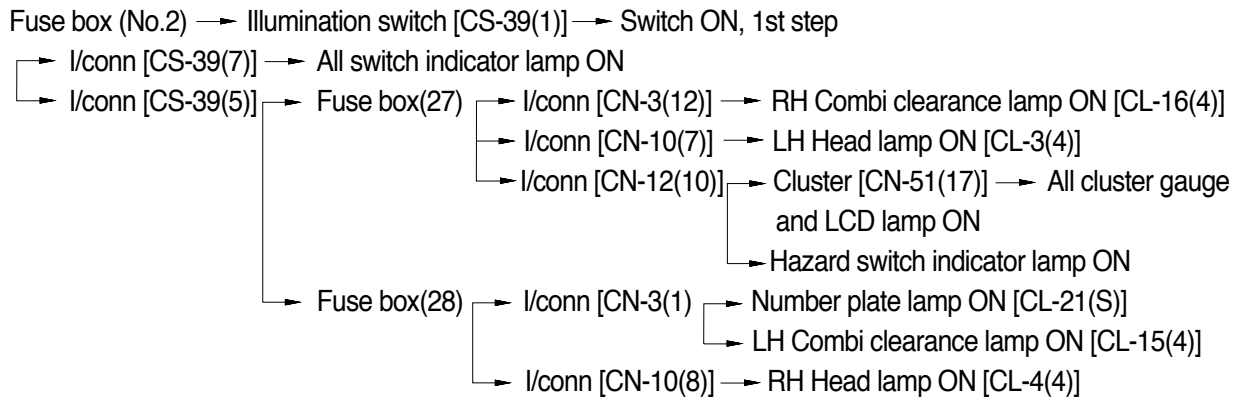

2) CHECK POINT

Engine	Key switch	Check point	Voltage
OFF	ON	- GND (Switch input) - GND (Switch output) - GND (To light) - GND (To cluster)	20~25V

GND : Ground

ILLUMINATION CIRCUIT

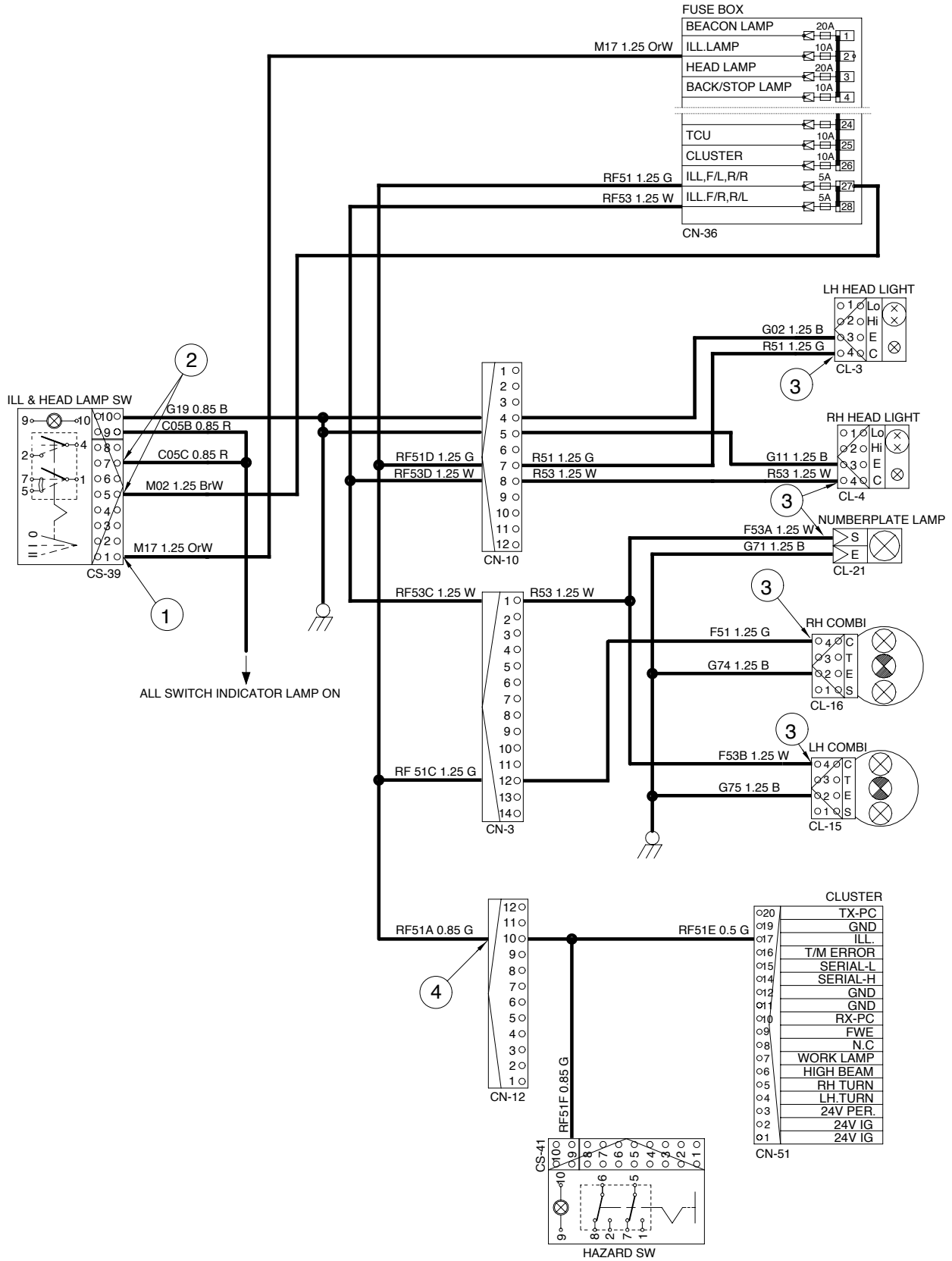

2. HEAD LIGHT CIRCUIT

1) OPERATING FLOW

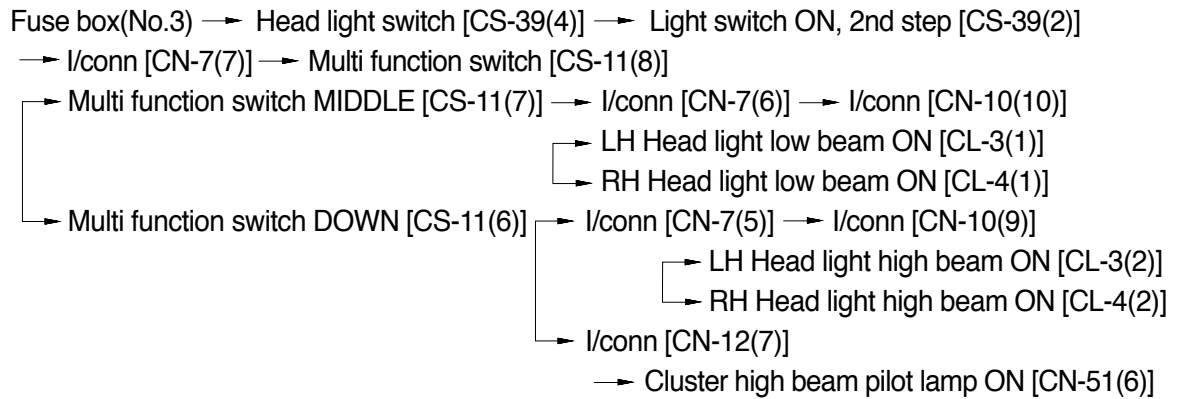

2) CHECK POINT

Engine	Key switch	Check point	Voltage
OFF	ON	- GND (Switch input) - GND (Switch output) - GND (Multi function input) - GND (Multi function output) - GND (Multi function output) - GND (Low beam) - GND (High beam) - GND (Passing B+)	20~25V

GND : Ground

HEAD LIGHT CIRCUIT

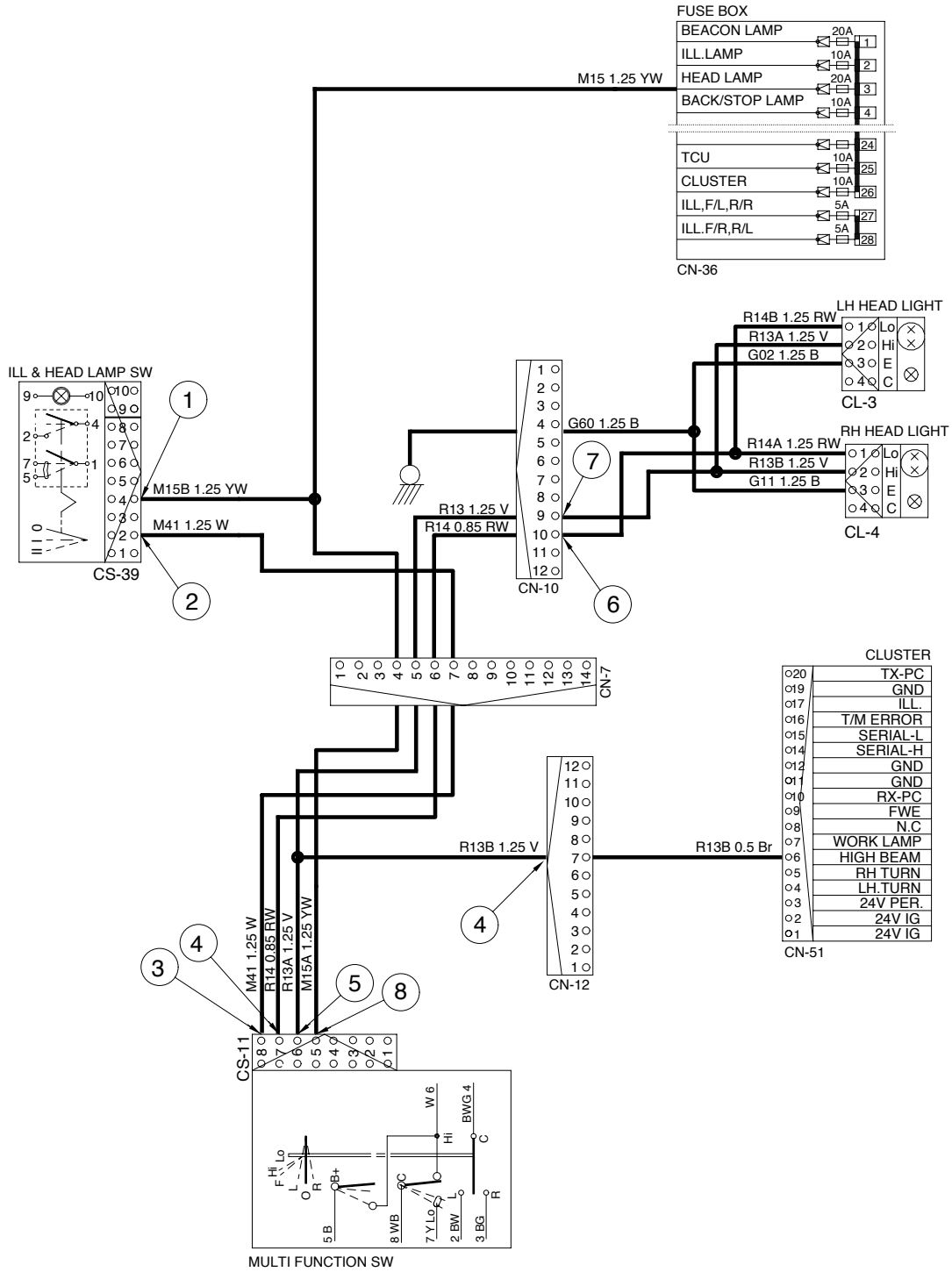

7707EL04

3. WORK LIGHT SWITCH

1) OPERATING FLOW

Illumination switch : ON position

(1) Work lamp switch ON (1st step)

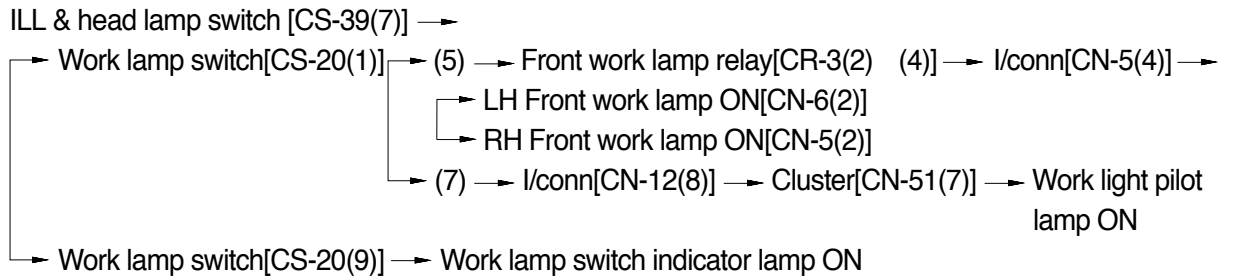

(2) Work lamp switch (2nd step)

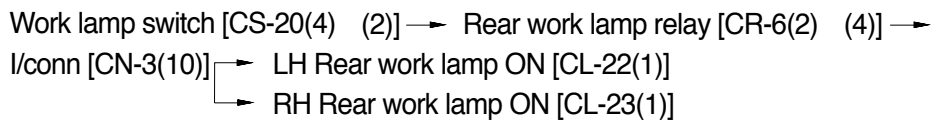

2) CHECK POINT

Engine	Key switch	Check point	Voltage
OFF	ON	<ul style="list-style-type: none"> - GND (Work lamp power input) - GND (Work lamp power output) - GND (Front work lamp) - GND (Rear work lamp) 	20~25V

GND : Ground

WORK LIGHT SWITCH

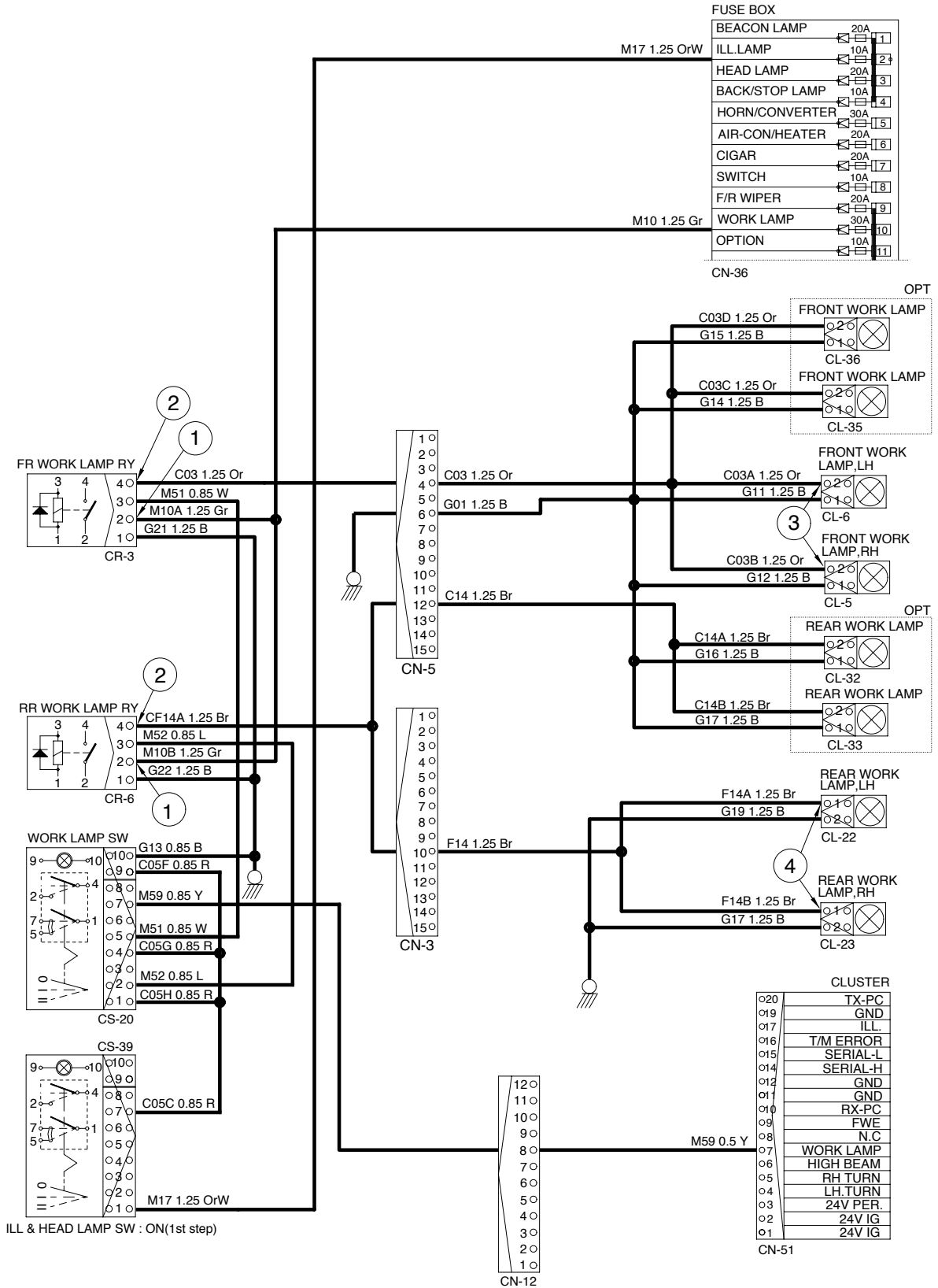

7607EL05

4. STARTING CIRCUIT

1) OPERATING FLOW

Battery(+) terminal → Battery relay(R4 terminal) → Fusible link [CN-60(1)]
 → I/conn [CN-1(1)] → Fuse box (No.15) → Start switch [CS-2(1)]

The gear selector lever is neutral position. It is necessary condition before the starting.

The gear selector has an output signal which is activated whenever the shift lever is in the neutral position. This signal can be used to control a relay and prevent engine from starting whenever the shift lever is not in the neutral position.

(1) When start key switch is in ON position

Start switch ON → Start switch [CS-2(2)] → I/conn [CN-3(6)] → Battery relay [CR-1]
 → Battery relay operating(All power is supplied with the electric component)
 → Start switch [CS-2(3)] → Fuse box [No.23] → Fuse box (No.22) →
 I/conn [CN-3(9)] → I/conn [CN-12(10)] → ECM[CN-92(A)]

(2) When start key switch is in START position

Start switch START [CS-2(5)] → Start safety relay [CR-5(30)] → Start safety relay [CR-5(87)]
 → I/conn [CN-2(11)] → [CN-4(7)] → Start relay [CR-23(2)] →
 Starter(Terminal B⁺ and M connector of start motor)

2) CHECK POINT

Engine	Key switch	Check point	Voltage
Running	ON	- GND (Battery B ⁺) - GND (Fusible link) - GND (Start key B terminal) - GND (Start key BR terminal) - GND (I/conn CN-3(6)) - GND (Start key ST terminal) - GND (Start safety relay output) - GND (Controller) - GND (Start key ACC terminal)	20~25V

GND : Ground

ECM : Electronic control module

STARTING CIRCUIT

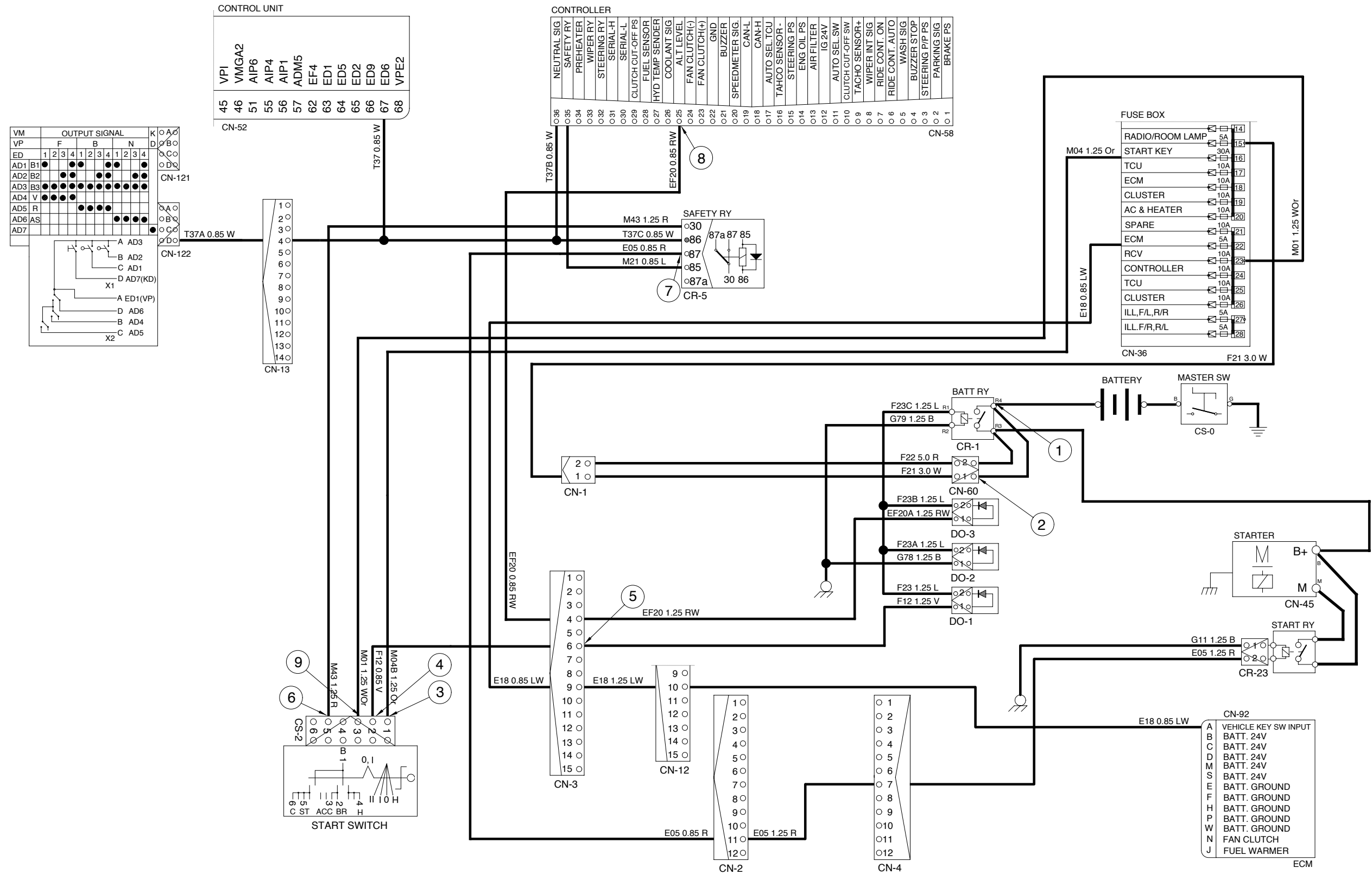

5. CHARGING CIRCUIT

When the starter is activated and the engine is started, the operator releases the key switch to the ON position.

Charging current generated by operating alternator flows into the battery through the battery relay (CR-1).

The current also flows from alternator to each electrical component and controller through the fuse box.

1) OPERATING FLOW

(1) Warning flow

Alternator [CN-74(1)] → I/conn [CN-4(8)] → I/conn [CN-3(4)] → Controller [CN-58(25)]
 → Cluster charge warning lamp ON

(2) Charging flow

Alternator → Starter [CN-45(B⁺)] → Battery relay [CR-1]
 ↳ Battery(+) terminal → Charging
 ↳ I/conn [CN-60(1),(2)] → I/conn [CN-1(1),(2)] → Fuse box

2) CHECK POINT

Engine	Key switch	Check point	Voltage
Running	ON	- GND (Battery) - GND (Battery relay) - GND (ALT B ⁺) - GND (ALT I) - GND (Controller) - GND (Fuse box)	20~28V

GND : Ground

CHARGING CIRCUIT

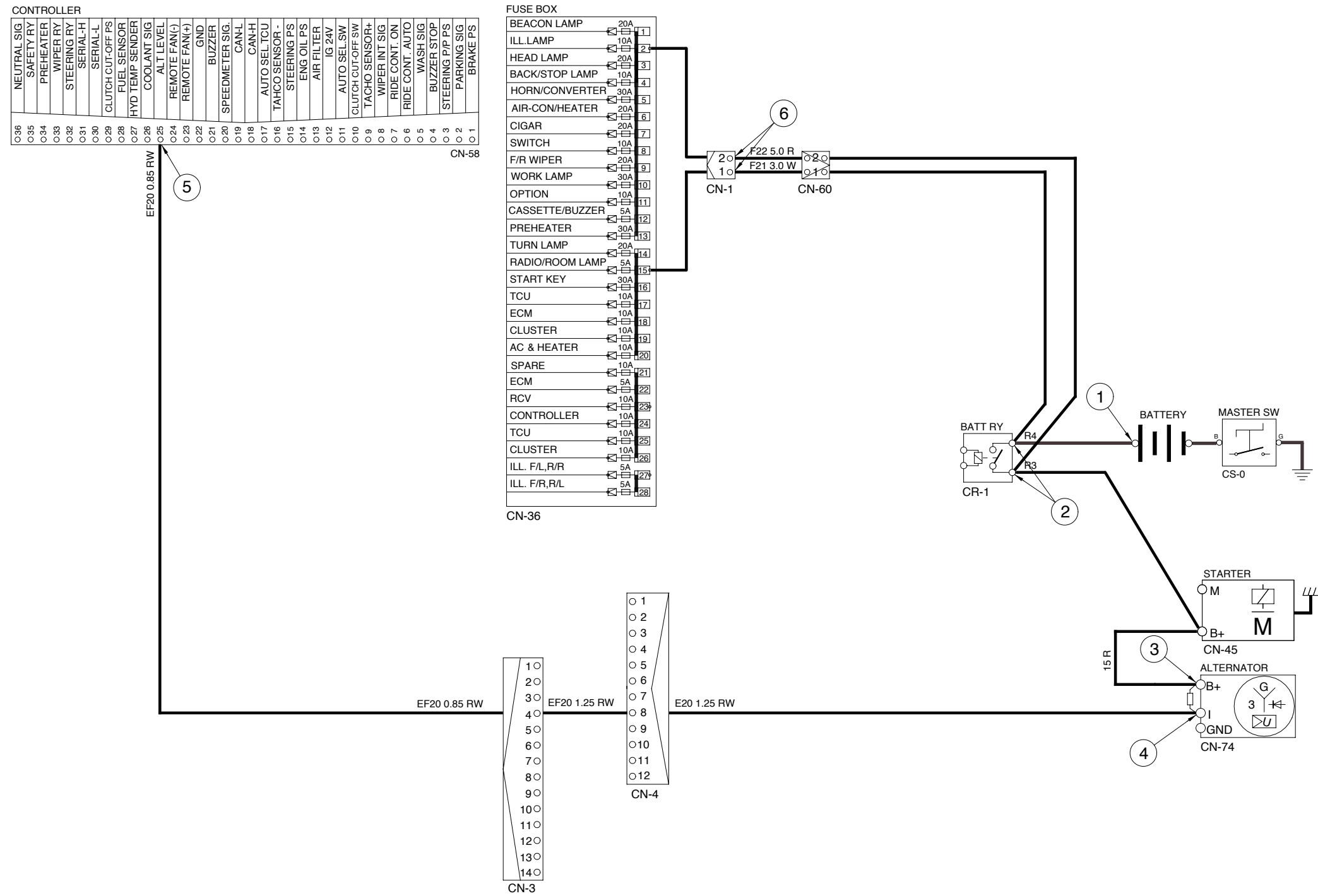

6. ELECTRIC PARKING, DECLUTCH CIRCUIT

1) OPERATING FLOW

(1) Parking OFF

Fuse box (No.8) → Parking switch OFF [CS-17(6)‡ (8)] → Parking solenoid ON (Activated)
 → Parking brake released (By hydraulic pressure)

(2) Parking ON

Fuse box (No.8) → Parking switch ON → Parking solenoid [CN-71] OFF
 → Parking brake applied [By spring force]
 → [CS-17(5)‡ (7)] → T/M control unit [CN-52(21)]
 → T/M declutch

(3) Declutch ON

Fuse box (No.8) → Clutch cut-off switch ON → Clutch cut-off switch [CS-42(5) ‡ (1)] →
 → Controller [CN-58(10)‡ (29)] → Service brake applied → Service brake pressure switch
 ON [CD-5] → T/M control unit [CN-52(66)] → Declutch

2) CHECK POINT

Engine	Key switch	Check point	Voltage
Running	ON	- GND (Parking switch input) - GND (Parking switch output) - GND (Parking switch input) - GND (Parking switch output) - GND (Parking solenoid) - GND (Pressure switch clutch cut-off)	20~25V

GND : Ground

ELECTRIC PARKING, DECLUTCH CIRCUIT

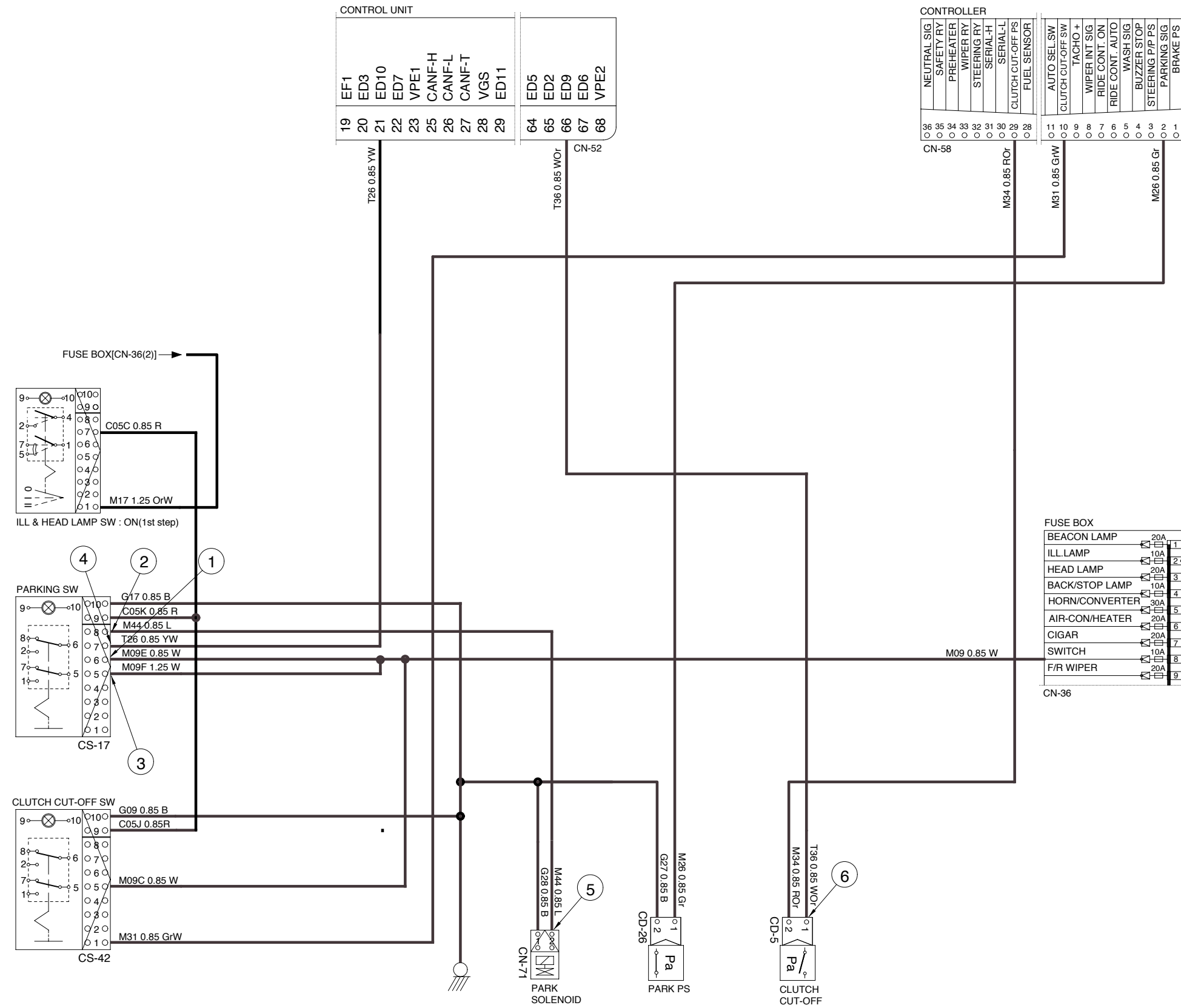

7. WIPER AND WASHER CIRCUIT

1) OPERATING FLOW

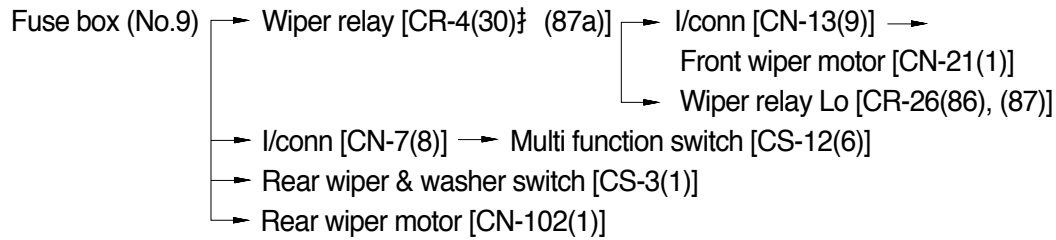

(1) Front washer switch ON

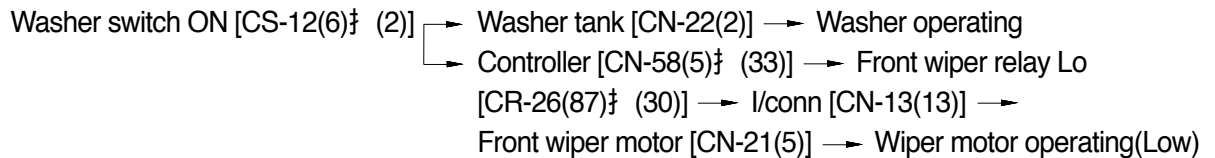

(2) Front wiper switch ON

INT position

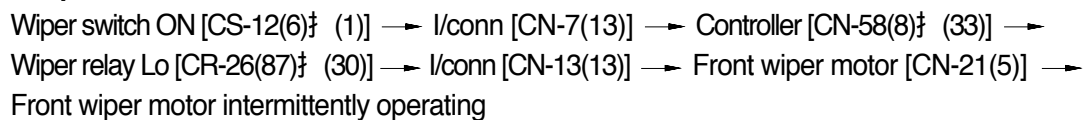

Lo position

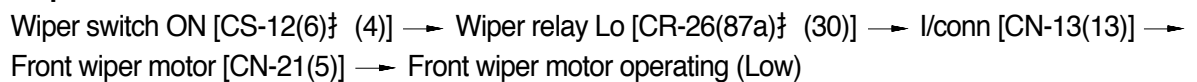

Hi position

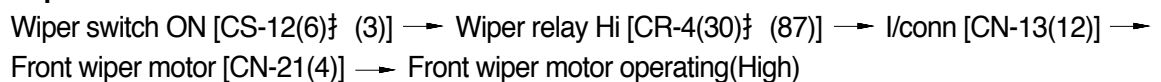

(3) Auto-parking(When switch OFF)

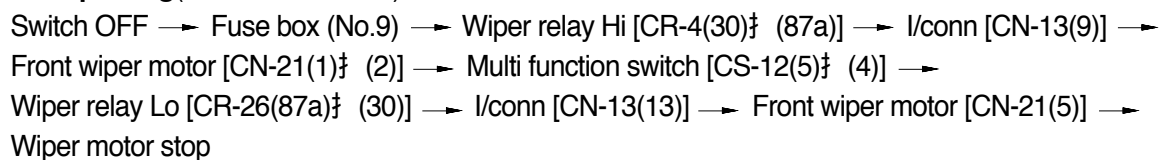

(4) Rear wiper and washer switch

Wiper switch ON(1st step)

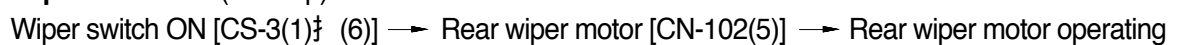

Washer switch ON(2nd step)



2) CHECK POINT

Engine	Key switch	Check point	Voltage
Stop	ON	<ul style="list-style-type: none">- GND (Front wiper switch power input)- GND (Rear wiper switch power input)- GND (Wiper relay power input)- GND (Front wiper motor Lo power input)- GND (Front wiper motor High power input)- GND (Wiper relay power input)- GND (Front washer power output)- GND (Rear washer power output)- GND (Front wiper motor power output)- GND (Rear wiper motor power output)	20~25V

GND : Ground

WIPER AND WASHER CIRCUIT

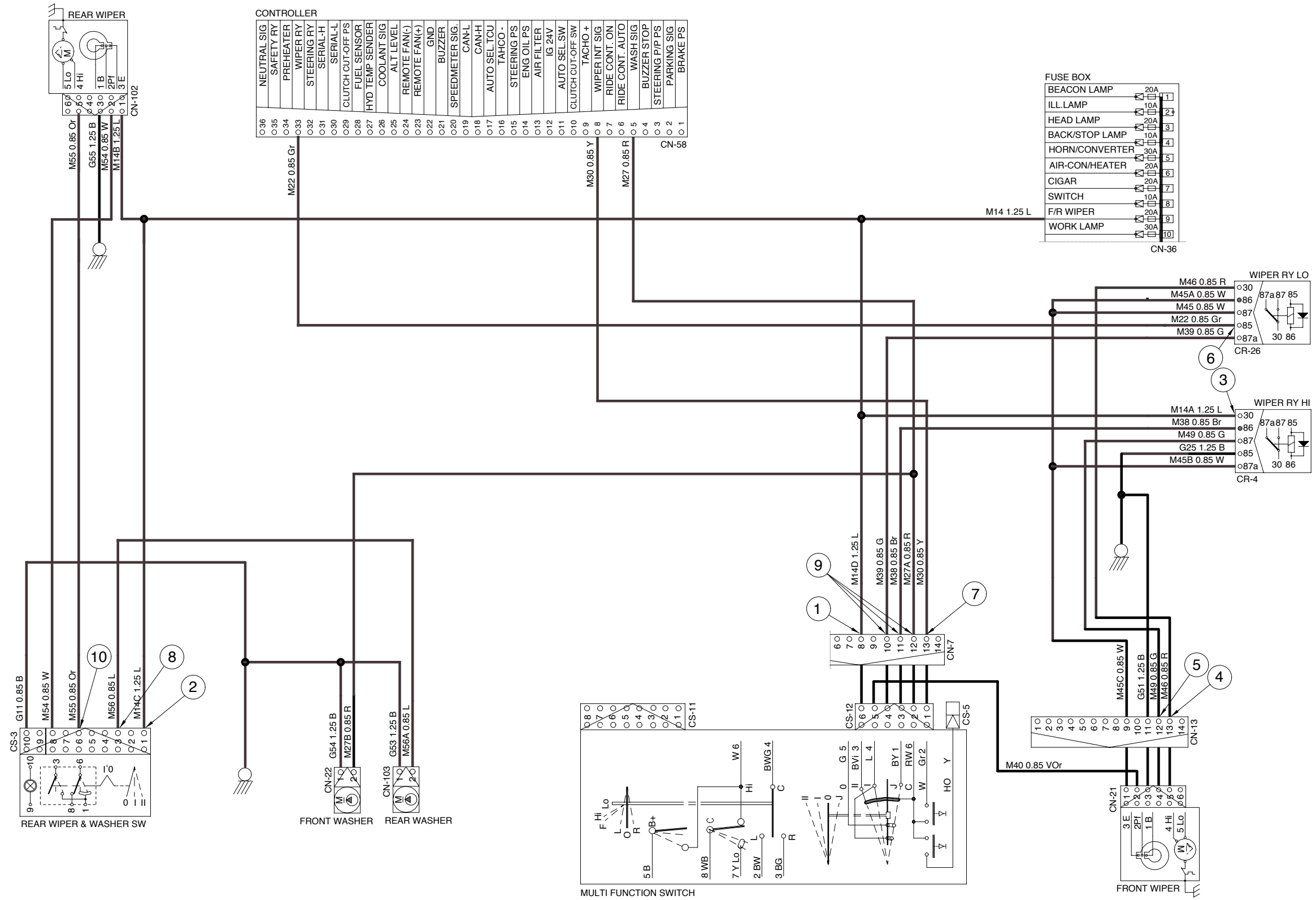

HAZARD, TURN AND ROTARY CIRCUIT

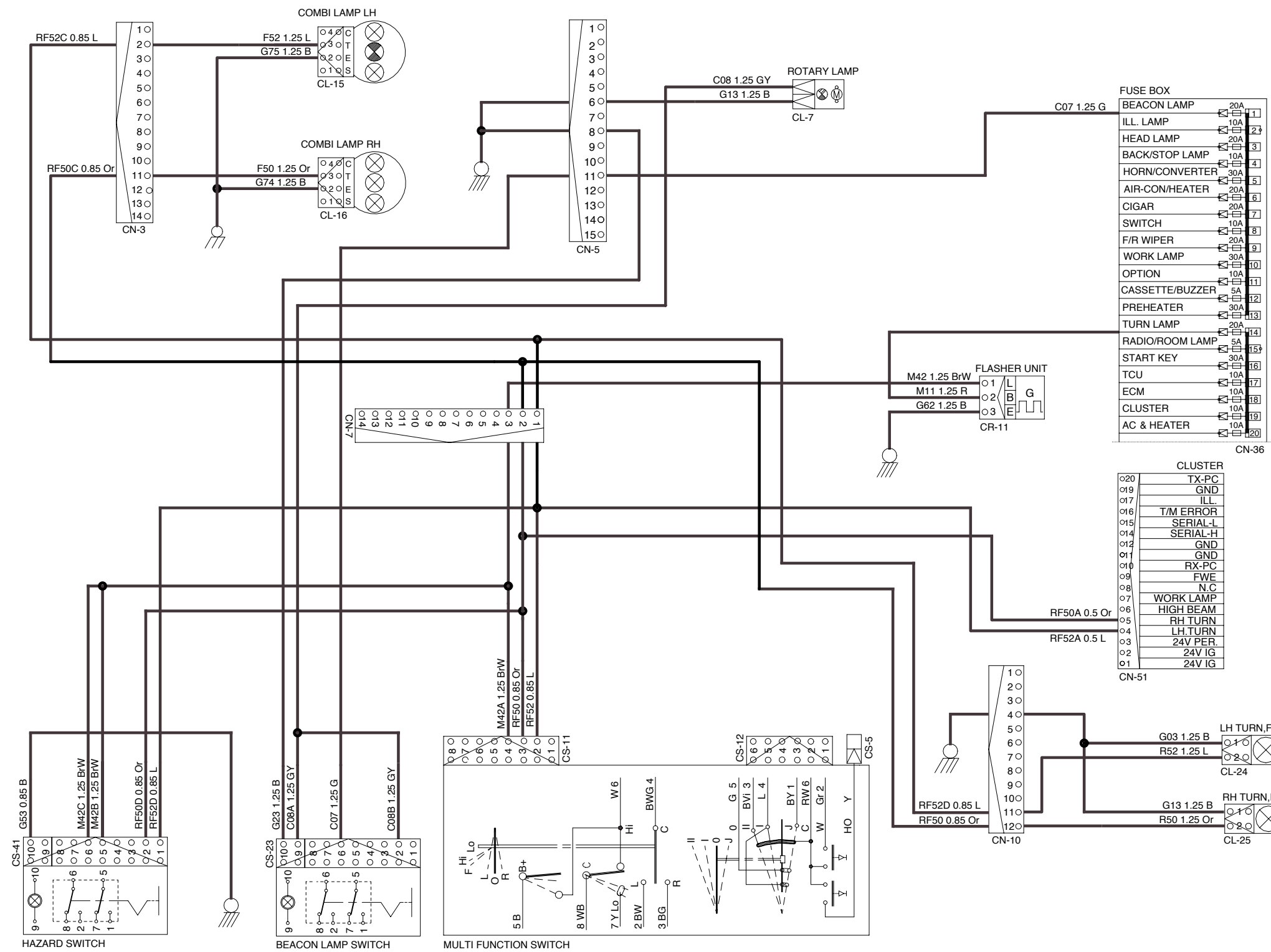

3. MONITORING SYSTEM

The gauges panel consists of gauges and monitors as shown below, to warn the operator in case of abnormal machine operation or conditions for the appropriate operation and inspection.

- Gauges : Indicate operating status of the machine.
- Warning lamp : Indicate abnormality of the machine.
- Pilot lamp : Indicate operating status of the machine.

The monitor installed on this machine does not entirely guarantee the condition of the machine. Daily inspection should be performed according to chapter 6, MAINTENANCE. When the monitor provides a warning immediately check the problem, and perform the required action.

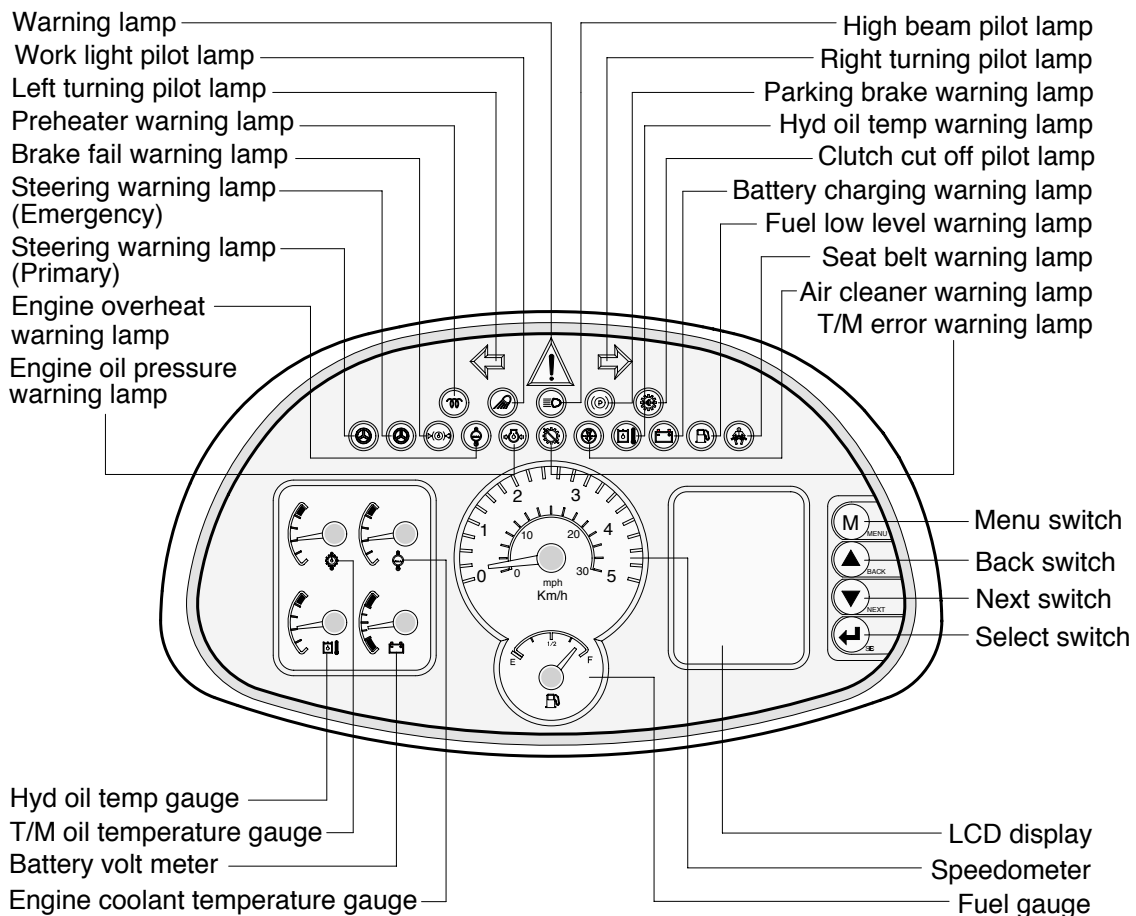

77073CD02

1) SPEEDOMETER

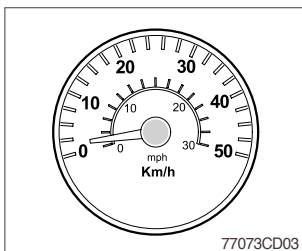

- (1) The speedometer displays the speed of machine in mph and km/h.

2) FUEL GAUGE

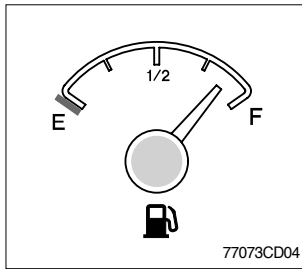

- (1) This gauge indicates the amount of fuel in the fuel tank.
- (2) Fill the fuel when the indicator moves **E** point, refuel as soon as possible to avoid running out of fuel.

If the gauge indicates below E point even though the machine is on the normal condition, check the electric device as that can be caused by the poor connection of electricity or sensor.

3) ENGINE COOLANT TEMPERATURE GAUGE

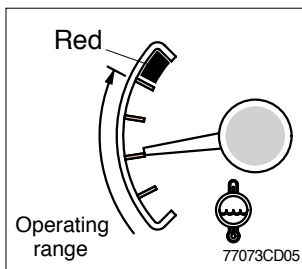

- (1) This indicates the temperature of coolant.
 - Red range : Above 104.°C (219.°F)
- (2) Keep idling engine at low speed until the indicator is in the operating range.
- (3) If the indicator is in the red range, turn OFF the engine, check the radiator and engine.

4) TRANSMISSION OIL TEMPERATURE GAUGE

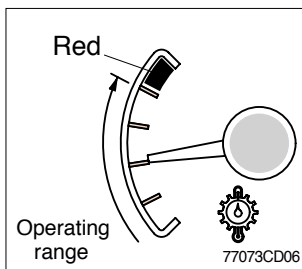

- (1) This range indicates the temperature of transmission oil.
 - Red range : Above 107.°C (225.°F)
- (2) Keep idling engine at low speed until the indicator is in the operating range.
- (3) If the indicator is in the red range, it means the transmission is overheated. Be careful that the indicator does not move into the red range.

5) BATTERY VOLT METER

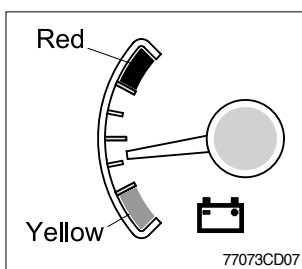

- (1) This gauge indicates the voltage in the charging system when the engine is running.
- (2) If the indicator is below 24V (Yellow range), it means that the electricity is being discharged. If the indicator is above 30V (Red range), an unusually high voltage may damage the alternator. Check the charging system in both cases.

6) HYD OIL TEMPERATURE GAUGE

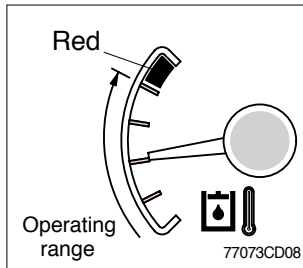

- (1) This range indicates the temperature of hydraulic oil.
 - Red range : Above 105. C (221. F)
- (2) Keep idling engine at low speed until the indicator is in the operating range.
- (3) If the indicator is in the red range, reduce the load on the system. If the gauge stays in the red range, stop the machine and check the cause of the problem.

7) WARNING LAMP

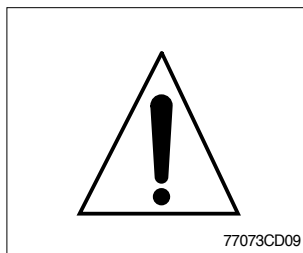

- (1) When all warning lamp or fault codes are being displayed, this warning lamp will flash.
- (2) When this warning lamp flashes, machine must be checked or serviced as soon as possible.

8) DIRECTION PILOT LAMP

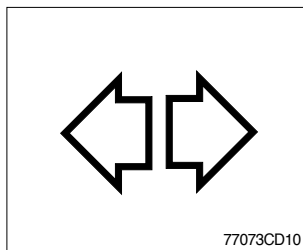

- (1) This lamp flashes when the signal indicator lever is moved.

9) WORK LIGHT PILOT LAMP

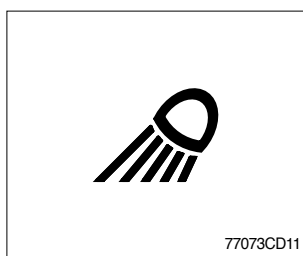

- (1) This lamp lights ON when work lamp switch is pressed.

10) HIGH BEAM PILOT LAMP

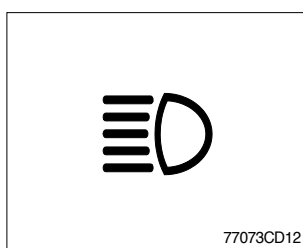

- (1) This lamp works when the illuminating direction is upward.
- (2) This lamp comes ON when the dimmer switch is operated, e.g., when passing another vehicle.

11) PARKING BRAKE WARNING LAMP

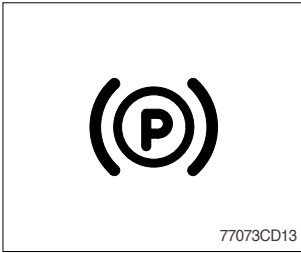

- (1) When the parking brake is actuated, the lamp lights ON.
Check the lamp is OFF before driving.

12) PREHEATER WARNING LAMP

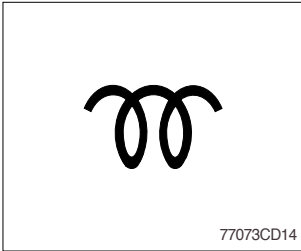

- (1) This lamp lights ON when start switch is turned clockwise to the ON position. Light will turn off after approximately 15~45 seconds, depending on engine temperature, indicating that preheating is completed.
- (2) When the lamp goes out the operator should start cranking the engine.

13) CLUTCH CUT OFF PILOT LAMP

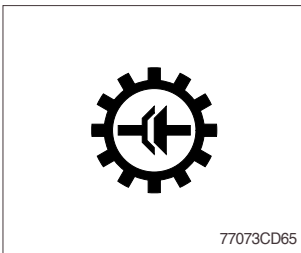

- (1) When the clutch cut off switch is pressed, the lamp lights ON.

14) BRAKE FAIL WARNING LAMP

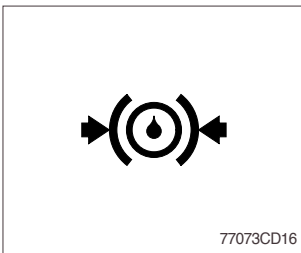

- (1) The lamp lights ON when the oil pressure of service brake drops below the normal range.
- (2) When the lamp is ON, stop the engine and check for its cause.
Do not operate until any problems are corrected.

15) ENGINE OVERHEAT WARNING LAMP

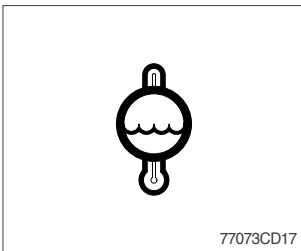

- (1) This lamp is turned ON when the temperature of cooling water is over the normal temperature(104. C, 219. F)
- (2) Check the cooling system when the lamp is ON.

16) ENGINE OIL PRESSURE WARNING LAMP

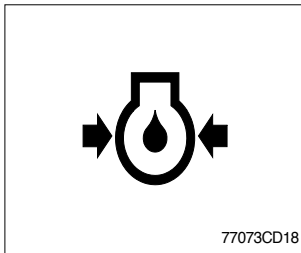

- (1) This lamp is comes ON after starting the engine because of the low oil pressure.
- (2) If the lamp comes ON during engine operation, shut OFF engine immediately. Check oil level.

17) TRANSMISSION ERROR WARNING LAMP

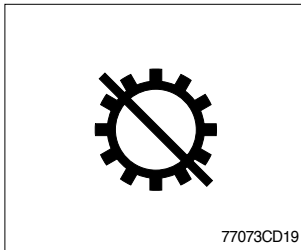

- (1) This lamp lights ON and the LCD display show the error codes when an error occurs in the transmission.
- (2) Immediately pull the machine to a convenient stop. Stop the engine. Investigate the cause.

**Consult a HYUNDAI dealer to investigate the cause.
Do not operate until the cause has been corrected.**

18) AIR CLEANER WARNING LAMP

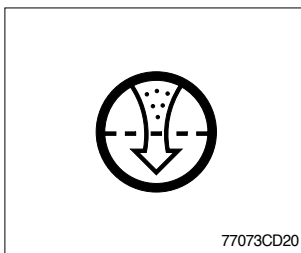

- (1) This lamp operates by the vacuum caused inside when the filter of air cleaner is clogged.
- (2) Check the filter and clean or replace it when the lamp is ON.

19) HYD OIL TEMPERATURE WARNING LAMP

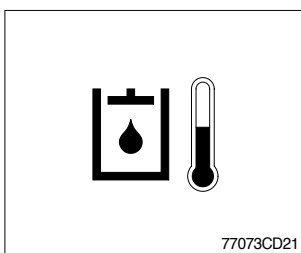

- (1) This warning lamp operates and the buzzer sounds when the temperature of hydraulic oil is over 105. C(221. F).
- (2) Check the hydraulic oil level when the lamp is turned ON.
- (3) Check for debris between oil cooler and radiator.

20) BATTERY CHARGING WARNING LAMP

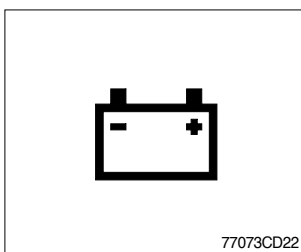

- (1) This lamp is ON when key ON, it is turned OFF after starting the engine.
- (2) Check the battery charging circuit when this lamp comes ON, during engine operation.

21) FUEL LOW LEVEL WARNING LAMP

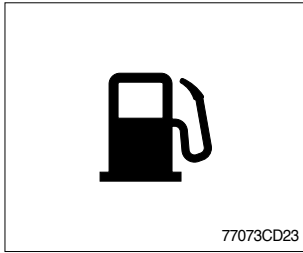

(1) Fill the fuel immediately when the lamp is turned ON.

22) SEAT BELT WARNING LAMP

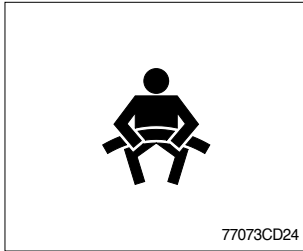

(1) This lamp lights ON for the first five seconds after starting the machine.

23) STEERING WARNING LAMP (Option)

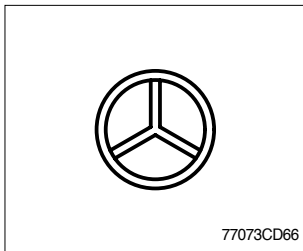

(1) Primary

This lamp indicates that the primary steering has failed. When the indicators come on and the action alarm sounds, steer the machine immediately to a convenient location and stop the machine. Stop the engine and investigate the cause.

Do not operate the machine until the cause has been corrected.

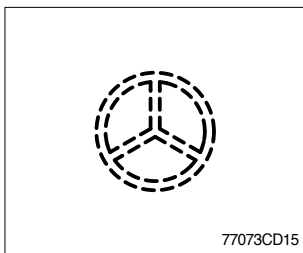

(2) Emergency

This lamp indicates the emergency steering system is active.

Immediately pull the machine to a convenient stop and stop the engine.

The emergency steering system can be manually tested.

Refer to page 7-35.

24) LCD

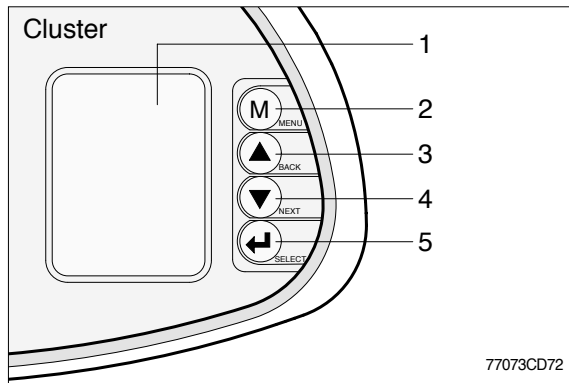

- 1 (□) LCD
- 2 (M) MENU
 - Display main menu
 - Return to the normal display
- 3 (▲) BACK
 - Return to the previous menu
- 4 (▼) NEXT
 - Move to the next selection
- 5 (↵) SELECT
 - Activate the currently chosen item

(1) Normal display

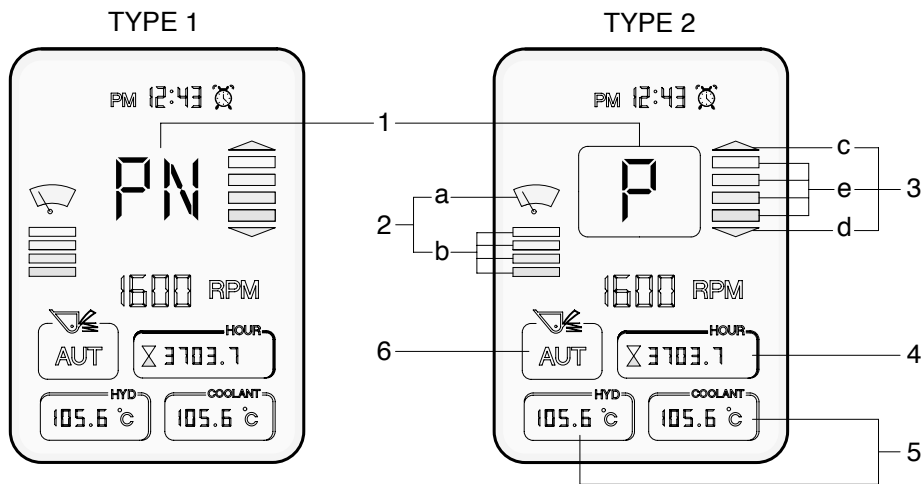

77073CD73

No	Symbol	Meaning	Remark
1	△, ▽, □	Forward, reverse, neutral	LCD type 1, Display during AEB mode
	F, R, N	Forward, reverse, neutral	LCD type 2, Display during AEB mode
	1, 2, 3, 4	Actual gear	Selected gear in semi-automatic mode
	P	Parking brake mode active	-
2	a	Wiper motor intermittently operating	-
	b	When operating intermittently, it shows an operating time interval.	-
3	c, d	Up and down shifting	c : Forward, d : Reverse
	e	Pre-selected gear	-
4		Hour meter	Display the total operation hours of the machine
5		Engine coolant temperature	Display in accordance with selected items
6 (Option)	AUT	Ride control mode active	Ride control switch AUTO position, see page 7-35
	ON	Ride control mode active	Ride control switch ON position, see page 7-35
	OFF	Ride control mode turn off	Ride control switch MIDDLE position, see page 7-35

Both type1 and type2 are LCD modes and they can be changed each other by operator's selection.

(2) Display map

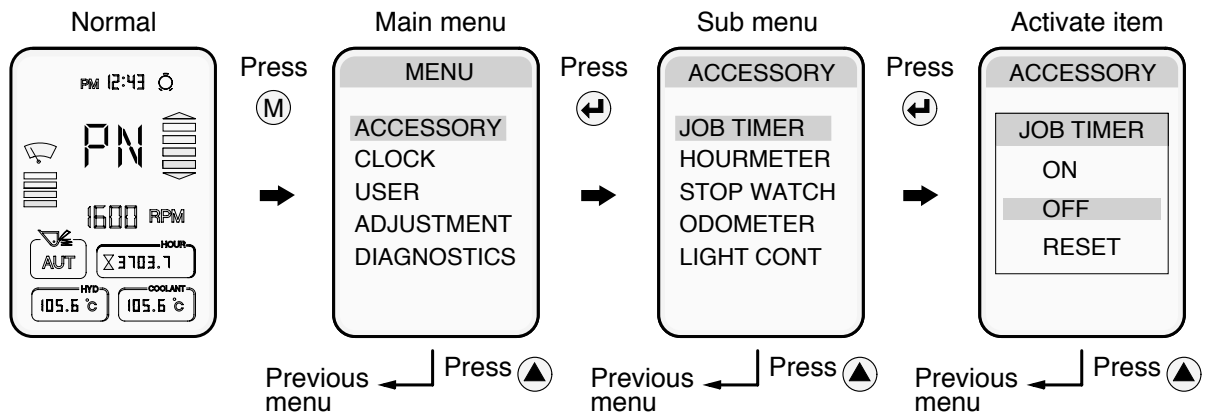

77073CD74

Main group	Sub group	Meaning	Display on LCD	
Accessory	Job timer	<ul style="list-style-type: none"> Measure the various job time. Press (←) : Display ON or OFF. 		
	Stop watch	<ul style="list-style-type: none"> Measures time in seconds. Press (←) : Start. Press (←) again : Stop. 	-	
	Odometer	Latest	Distance until recent times.	
		Total	Total distance.	
	Light control	<ul style="list-style-type: none"> Control of LCD display luminosity. Brightness control : (▲) , (▼) . 	-	
Clock	Time set	<ul style="list-style-type: none"> When 12H or 24H is selected, the current hour appears. (▲) , (▼) : input, (←) : setting. 	PM 12:43	
	Clock ON/OFF	<ul style="list-style-type: none"> (←) : Clock display ON or OFF. 		
	Alarm	1	<ul style="list-style-type: none"> Alarm setting. It is possible to set 3 alarms. Stop alarming : (←) or buzzer stop switch. 	
		2		
3				
User	Alternate idle	<ul style="list-style-type: none"> Raise the idle rpm to 1200rpm automatically to warm up the engine. 	-	
	Auto 1/2	Mode 1 (1st-4th)	Automatic travelling speed is applied from 1st to 4th gear.	-
		Mode 2 (2nd-4th)	Automatic travelling speed is applied from 2nd to 4th gear.	-
	Quick shift	Mode 1 (Down/Up)	Press button once : Shift down, press button again ; shift up.	-
		Mode 2 (Down)	Press button every time : Shift to lower gear respectively.	-
	Aux-sw	Auto Select	<ul style="list-style-type: none"> ON : Transmission auto condition. OFF : Transmission semi-auto condition. 	
Clutch Cut-off		<ul style="list-style-type: none"> ON : Clutch cut-off is activated. OFF : Clutch cut-off is cancelled. 	-	

Main group	Sub group	Meaning	Display on LCD display	
Adjustment	Unit	· Choose between metric and inch unit display.		
	Wiper Intermittence	· When using the intermittent function of wiper motor, it regulates operation time.		
	Alternate RPM	· Regulate idle rpm. · Press ▲, ▼ : Adjust idle rpm increments (or decrement) by 25rpm.	-	
	Pulse	· Press ← : Modification.	-	
	AEB	· It controls the disk interval of the transmission, automatically.	-	
	ENG/KOR	· English : Display in English. · Korean : Display in Korean.	-	
	Display 1/2	· Type 1 : Indicate with the symbol. · Type 2 : Indicate with a letter.		
Diagnostics	Machine	Fault Code	· Error code display. · Refer to page 7-30.	-
		Monitor	· Hydraulic temperature and battery voltage display. · Press ← : Display ON or OFF.	
	Engine	Fault Code	· Error code display. · Refer to page 7-30.	-
		Monitor	· Engine coolant temperature display · Press ← : Display ON or OFF.	
	Transmission	Fault Code	· Error code display. · Refer to page 7-30.	-
		Monitor	Transmission oil temperature display. · Press ← : Display ON or OFF.	

(3) Fault code

When selecting the fault code menu, it shows all of the fault codes which mean abnormal conditions of present time.

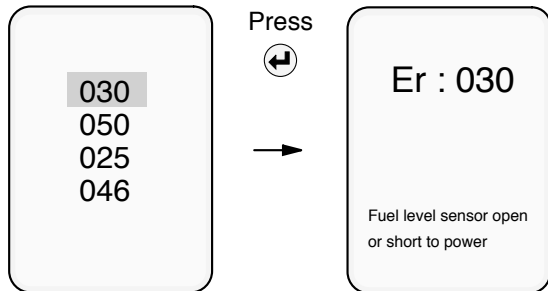

77073CD60

To go out from fault explanation window, press button.

(Press ,) to go out to first menu.)

No error will be indicated in case that there's no fault.

Description	Code	Meaning	Remark
Electrical system	010	Power input voltage low	Below 18V
	011	Power input voltage high	Above 38V
	012	Alternator voltage low	Below 5V
	013	Alternator voltage high	Above 36V
	014	Buzzer circuit open or short to ground	
	015	Buzzer circuit short to power	
	016	Wiper relay open or short to ground	
	017	Wiper relay short to power	
Hydraulic system	020	Hydraulic oil temperature sensor open or short to power	
	021	Hydraulic oil temperature sensor short to ground	
Engine system	030	Fuel level sensor open or short to power	
	031	Fuel level sensor short to ground	
	032	Safety relay open or short to ground	Restarting prevention
	033	Safety relay short to power	Restarting prevention
	034	Cooling fan driving valve open or short to ground	
	035	Cooling fan driving valve short to power	
T/M system	050	Auto select switch supply power open or short to power	
	051	Auto select switch supply power short to ground	
	052	Clutch cutoff supply power open or short to power	
	053	Clutch cutoff supply power short to ground	
Steering system	060	Emergency steering relay open or short to ground	Option
	061	Emergency steering relay short to power	Option
Communication	070	MCU communication error	
	071	TCU communication error	
	072	ECM communication error	
Others	080	Speedometer output signal(from TCU) bad	
	081	MCU memory error	
	082	MCU clock error	
	083	MCU clock battery error	
	084	Monitor memory error	

MCU : Machine control unit TCU : Transmission control unit ECM : Engine control module

(4) Transmission warning

Symbol	Meaning	Remarks
LF, LR	Limp home gear	-
F/R/ / flashing	Direction F or R selected while turbine speed is too high, CAUTION gear will engage if turbine speed drops	-
NN	Not neutral, waiting for neutral after power up or a severe fault	To engage a gear, first move shift selector to neutral position and again to F or R position
油 油	Oil temperature too low, no gear available	Warm up engine / transmission
油 N	Oil temperature low, only one gear available	Warm up engine / transmission
WS	Warning sump temperature	Changes between actual gear/direction while driving, in neutral only displayed if no fault is detected
WR	Warning retarder temperature	Changes between actual gear/direction while driving, in neutral only displayed if no fault is detected
WT	Warning torque converter temperature	Changes between actual gear/direction while driving, in neutral only displayed if no fault is detected
WE	Warning high engine speed	Changes between actual gear/direction while driving, in neutral only displayed if no fault is detected

3. SWITCHES

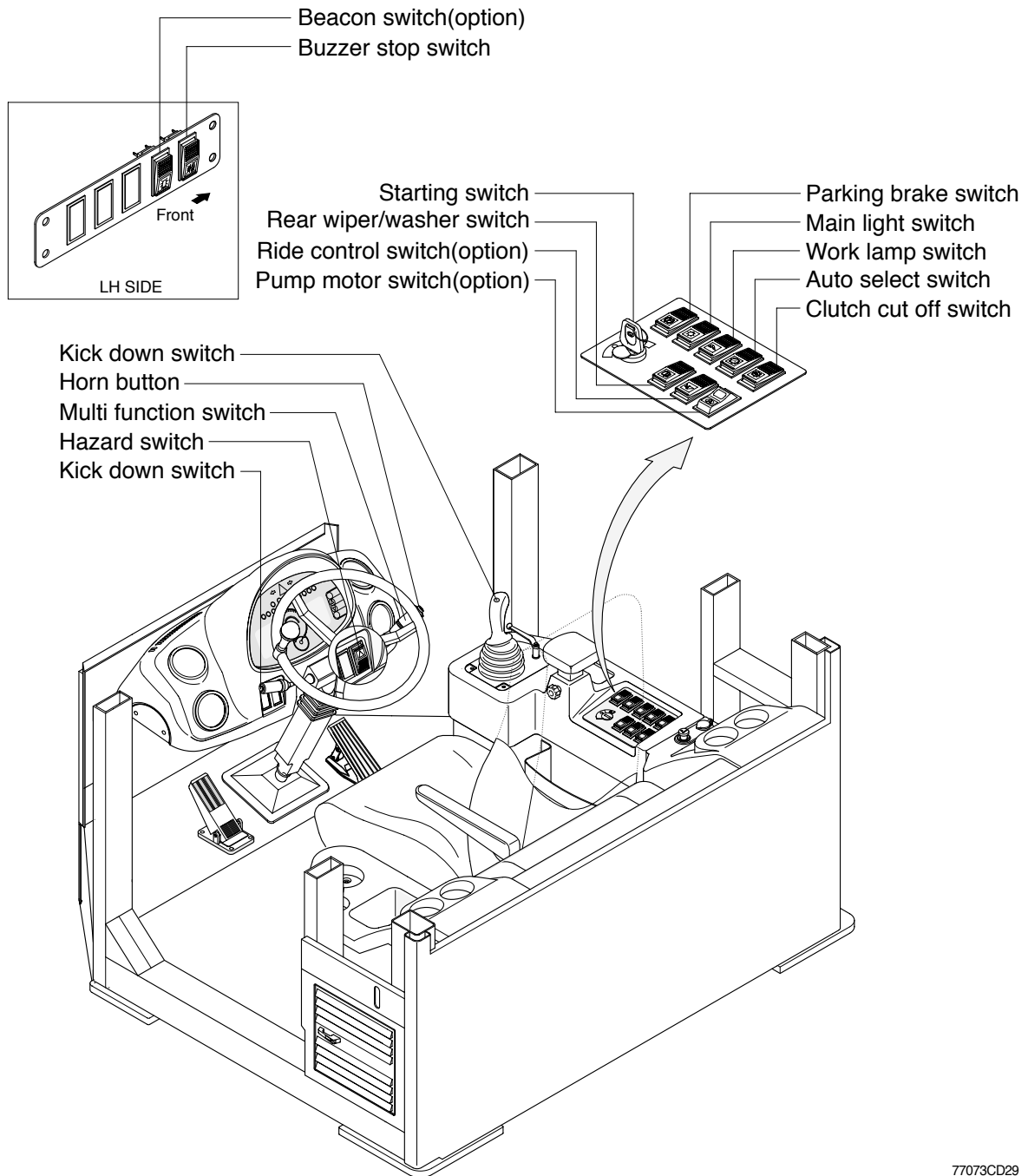

77073CD29

1) STARTING SWITCH

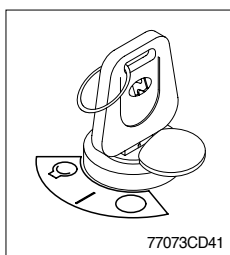

(1) There are three positions, OFF, ON and START.

- ○ (OFF) : None of electrical circuits activate.
- | (ON) : All the systems of machine operate.
- Ⓚ (START) : Use when starting the engine.

Release key immediately after starting.

Key must be in the ON position with engine running maintain electrical and hydraulic function and prevent serious machine damage.

2) HAZARD SWITCH

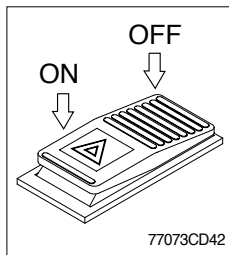

(1) Use for parking, or roading machine.

If the switch is left ON for a long time, the battery may be discharged.

3) CLUTCH CUT OFF SWITCH

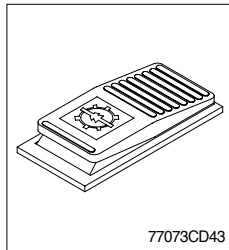

(1) This switch is pressed, it will cut off the clutch when brake operates.

Be careful not to use this switch when driving on a slope.

(2) When the switch failure occurs, it will be able to operate a clutch off function from LCD.

Refer to page 7-28.

4) PARKING BRAKE SWITCH

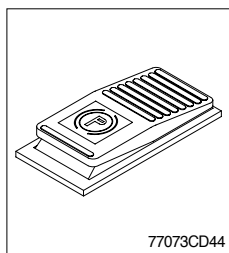

(1) This switch is pressed, the parking brake will start to operate and the gauge panel warning lamp will comes ON.

When operating the gear selector lever, be sure to release the parking brake. If the machine is operated with the parking brake engaged, the brake will overheat and may cause the brake system to go out of order.

5) MAIN LIGHT SWITCH

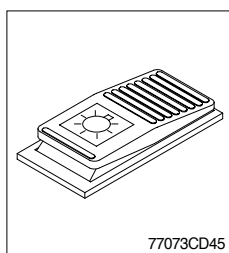

(1) This switch use to operates the clearance lamp and head light by two step.

- First step : Clearance lamp and cluster illumination lamp comes ON. Also, all indicator lamp of switches come ON.
- Second step : Head light comes ON.

6) WORK LAMP SWITCH

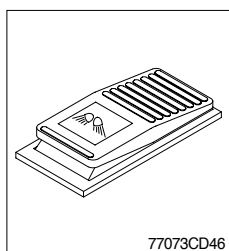

(1) This switch use to operates the front and rear work lamps by two step.

- First step : Front work lamp located on the cab comes ON.
- Second step : Rear work lamp located on the cowl comes ON.

7) REAR WIPER AND WASHER SWITCH

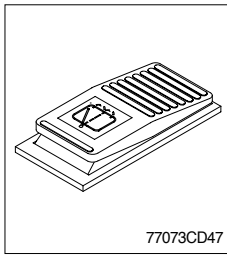

- (1) The switch use to operates the rear wiper and washer by two step.
- First step : The rear wiper operates.
 - Second step : The washer liquid is sprayed and the rear wiper is operated only while pressing. If release the switch, return to the first step position.

8) BUZZER STOP SWITCH

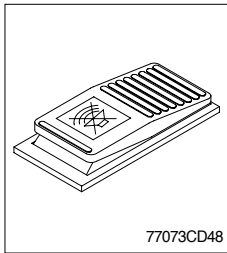

- (1) The red lamp on the cluster lights ON and the buzzer sounds when the machine has a problem.
In this case, if the switch is pressed, the buzzer will be stopped. Be sure to check machine for problems.
- (2) Wait until the lamp is turned OFF, if the red lamp lights ON after the buzzer stopped.
If not, stop engine and check the system which the lamp is ON.

9) AUTO SELECT SWITCH

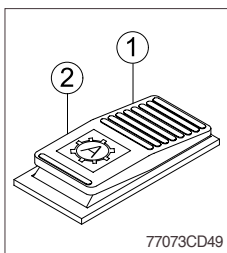

- (1) **Manual mode** ()
Press the top of the switch for the manual mode of the autoshift function. The operator selects the desired speed and the desired direction in the manual mode with the gear selector lever.
- (2) **Automatic mode** ()
Press the bottom of the switch for the autoshift function in the automatic mode. Press the bottom of the switch prior to shifting the transmission into forward or reverse in order to activate the autoshift function.
- When the switch failure occurs, it will be able to operate a auto select function from LCD.**
Refer to page 7-28.

10) BEACON SWITCH (Option)

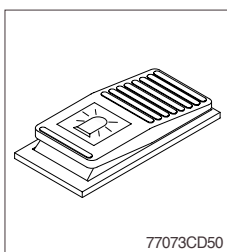

- (1) This switch turns ON the rotary light on the cab.

11) RIDE CONTROL SWITCH (Option)

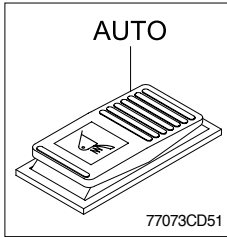

(1) AUTO position

Push in the top of the ride control switch in order to turn on the automatic ride control. The automatic ride control automatically turns on when the travel speed exceeds a preset speed of approximately 9.5km/h. The automatic ride control automatically shuts off during low speed 8km/h travel mode.

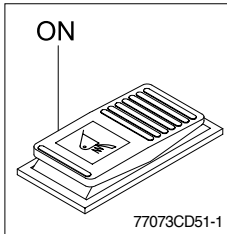

(2) ON position

Push in the bottom of the ride control switch in order to turn on the system for ride control regardless speed. The ride control will smooth the ride of the machine during travel.

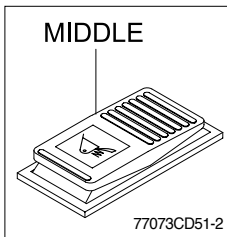

(3) MIDDLE position

Push the ride control switch to the middle position in order to turn off the system for the ride control.

12) PUMP MOTOR SWITCH (option)

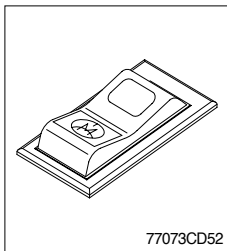

(1) The emergency steering system can be manually tested. Push the pump motor switch in order to determine if the emergency steering and the emergency steering lamp are functional.

(2) When the switch is pushed, the emergency steering pump motor will run. The emergency steering lamp will light. If the emergency steering lamp does not light, do not operate the machine.

13) HORN BUTTON

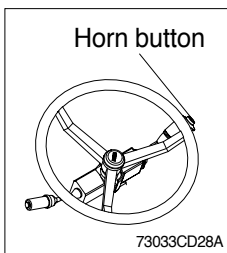

(1) If you press the button on the top of the multifunction switch, the horn will sound.

14) CAB LAMP SWITCH

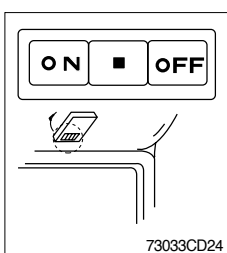

(1) This switch turns ON the cab room lamp.

15) KICK DOWN SWITCH

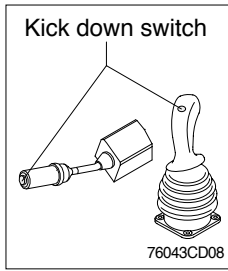

- (1) The kick-down switch into first gear is not allowed. Press the switch and release the switch. The transmission downshift one gear speed, provided that an engine overspeed would not occur.

16) MULTI FUNCTION SWITCH

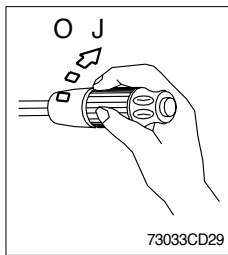

(1) Front wiper and washer switch

When the switch is in **J** position, the wiper moves intermittently. When placed in **I** or **II** position, the wiper moves continuously. If you press a button at the end of the lever, washer liquid will be sprayed and the wiper will be activated 2-3 times.

- ※ **Check the quantity of washer liquid in the tank. If the level of the washer liquid is LOW, add the washer liquid (In cold, winter days) or water. The capacity of the tank is 1 liter.**

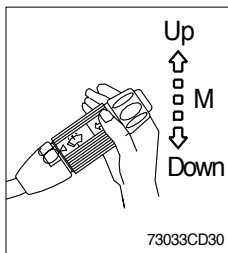

(2) Dimmer switch

This switch is used to turn the head lights direction.

Switch positions

- Up : To flash for passing
- Middle : Head lights low beam ON
- Down : Head lights high beam ON

If you release the switch when it's in up position, the switch will return to middle.

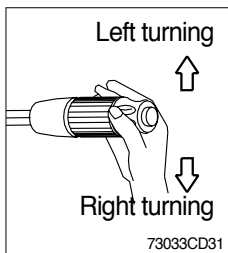

(3) Turning switch

This switch is used to warn or signal the turning direction of the machine to other vehicles or equipment.

Push the lever up for turning left, pull the lever down for turning right.

GROUP 4 ELECTRICAL COMPONENT SPECIFICATION

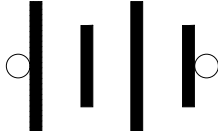
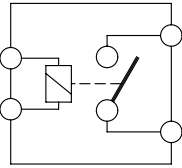
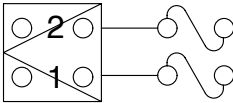
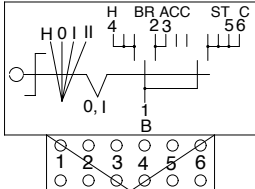
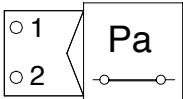
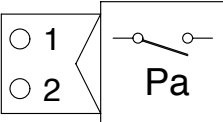
Part name	Symbol	Specifications	Check
Battery		12V × 200Ah (2EA)	Check specific gravity 1.280 over : Over charged 1.280 ~ 1.250 : Normal 1.250 below : Recharging
Battery relay	 <p style="text-align: center;">CR-1</p>	Rated load : 24V 100A(Continuity) 1000A(30seconds)	Check coil resistance Normal : About 50 Check contact Normal :
Fusible link	 <p style="text-align: center;">CN-60</p>	24V 60A	Check disconnection Normal : 0 (Connect ring terminal and check resistance between terminal 1 and 2)
Start key	 <p style="text-align: center;">CS-2</p>	-	Check contact OFF : (For each terminal) ON : 0 (For terminal 1-3) (For terminal 1-5) START : 0 (For terminal 1-3 and 1-5)
Pressure switch	 <p style="text-align: center;">CD-3 CD-26 CD-39 CD-41</p>	N.C TYPE	Check contact Normal : 0 (CLOSE)
Pressure switch	 <p style="text-align: center;">CD-4 CD-40 CD-5 CD-52</p>	N.O TYPE	Check contact Normal : (OPEN)

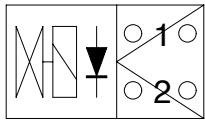
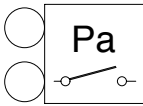
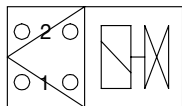
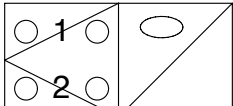
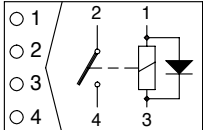
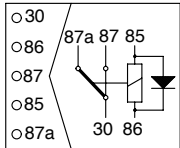
Part name	Symbol	Specifications	Check
Solenoid valve	 CN-137	24V 1A	Check resistance Normal : 15~25 (For terminal 1-2)
Air cleaner pressure switch	 CD-10	Pressure : 635mmH ₂ O (N.O TYPE)	Check contact Normal :
Parking solenoid	 CN-71	24V 1.2A	Check LED lamp Check Resistance About 24
Fuel sender	 CD-2	Reed switch : Magnetic type	Check resistance Full : About 30 Low level : About 300
Relay (4pin)	 AC RY(H1) AC RY(H2) CR-35 CR-42 CR-3 CR-6 CR-7 CR-46 CR-2	24V 20A	Check resistance Normal : About 200 (For terminal 1-3) : (For terminal 2-4)
Relay (5pin)	 CR-4 CR-5 CR-26 CR-30 CR-40 CR-41	24V 20A	Check resistance Normal : About 160 (For terminal 2-6) : 0 (For terminal 1-3) : (For terminal 1-3)

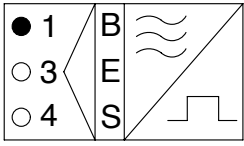
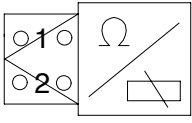
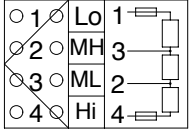
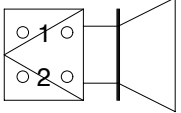
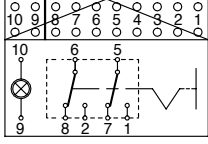
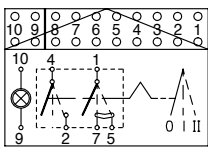
Part name	Symbol	Specifications	Check
Proximate switch	 <p>CN-100 CN-101</p>	24V 400mA	
Hydraulic temperature	 <p>CD-1</p>		Check resistance Normal : 105, C over : 0
Aircon resistor			Check contact Normal 1.12 : (For terminal 2-4) 2.07 : (For terminal 3-4) 3.17 : (For terminal 4-1)
Speaker	 <p>CN-23(LH) CN-24(RH)</p>	4 20W	Check resistance Normal : 50
Switch (Locking type)	 <p>CS-17 CS-23 CS-34 CS-41 CS-42 CS-51</p>	24V 8A	Check contact OFF : (for terminal 1-5, 2-6) : 0 (for terminal 5-7, 6-8)
Switch (Non-locking type)	 <p>CS-3 CS-34 CS-39</p>	24V 8A	Check contact OFF : (for terminal 2-4, 1-7)

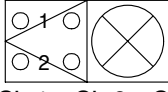
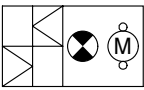
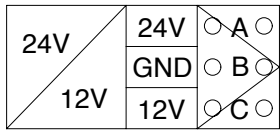
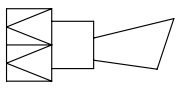
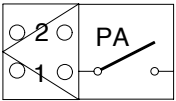
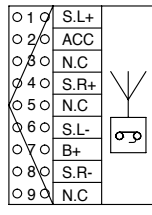
Part name	Symbol	Specifications	Check
Work lamp, Room lamp, Number plate lamp	 CL-1 CL-6 CL-22 CL-5 CL-21 CL-23 CL-24 CL-25 CL-30	Work lamp 24V 70W Number plate lamp Room lamp 24V 10W	Check disconnection Normal : A few
Beacon lamp	 CL-7	24V 70W (H1 TYPE)	Check disconnection Normal : A few
DC/DC Converter		12V 3A	24V (A-B) 12V (B-C)
Horn	 CN-20 CN-25	22-28V 2A 110dB	Check operation Supply power(24V) to each terminal and connect ground
Receiver dryer	 CN-29	24V 2.5A	Check contact Normal :
Cassette radio	 CN-27	24V 20W+20W	Check resistance Power ON : 4 +4 (for terminal 1-6, 4-8)

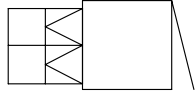
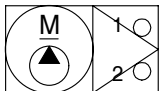
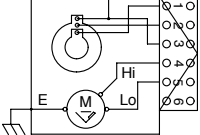
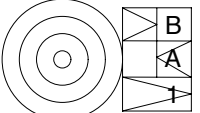
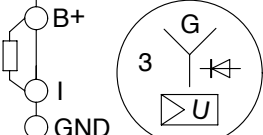
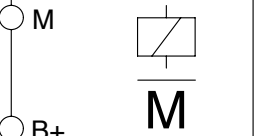
Part name	Symbol	Specifications	Check
Back up buzzer	 <p>CN-65</p>	24V 0.5A 110dB	-
Washer pump	 <p>CN-103 CN-22</p>	24V 2.5A	Check contact Normal : 26.4 (for terminal 1-2)
Wiper motor	 <p>CN-102 CN-21</p>	24V 1.5A 2-speed Auto parking	-
Cigar lighter	 <p>CL-2</p>	24V 5A	-
Alternator	 <p>CN-74</p>	20V 60A	Check voltage Normal : 24~28V
Starter	 <p>CN-45</p>	Delco Remy 28MT 24V	Operating or not

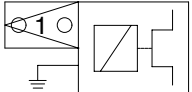
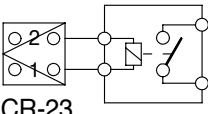
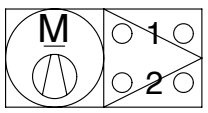
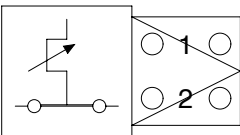
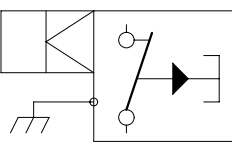
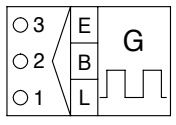
Part name	Symbol	Specifications	Check
Aircon compressor	 <p style="text-align: center;">CN-28</p>	24V 79W	Check contact Normal : 13.4
Start relay	 <p style="text-align: center;">CR-23</p>	24V 200A	Check contact Normal : 11.3
Blower		24V 9A 2900 ± 150rpm	-
Duct sensor		1.0 C OFF 4.0 C ON	Check resistance Normal : 0 (for terminal 1-2), the atmosphere temp: over 4.0 C
Door switch	 <p style="text-align: center;">CS-1 CS-55</p>	24V 2W	Check resistance Normal : About 5M
Flasher unit	 <p style="text-align: center;">CR-11</p>	24V 85 ~ 190 C/M 50dB	-

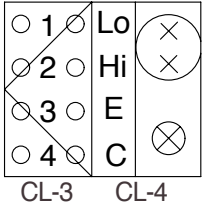
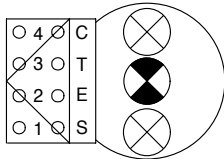
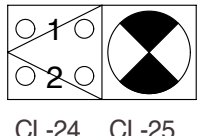
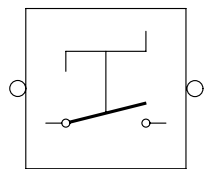
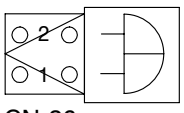
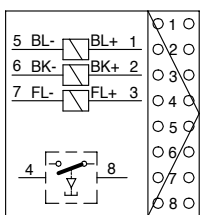
Part name	Symbol	Specifications	Check
Head lamp	 <p>CL-3 CL-4</p>	24V 75W/70W (H4 TYPE) 24V 4W (T4W)	Check disconnection Normal : A few
Combi lamp	 <p>CL-15 CL-16</p>	24V 5W (R5W) 2 × 24V 21W (P21W)	-
Turn lamp	 <p>CL-24 CL-25</p>	24V 21W (P21W)	-
Master switch		Continuous capacity : 180Amp Push in capacity : 1000Amp	-
Warning buzzer	 <p>CN-26</p>	24V 200mA 90 ± 5dB(m)	-
Joy stick lever	 <p>CN-114</p>	-	Check contact Normal : 80~90 (For terminal 1-5, 2-6 3-7,) : (For terminal 4-8)

GROUP 5 CONNECTORS

1. CONNECTOR DESTINATION

Connector number	Type	No. of pin	Destination	Connector part No.	
				Female	Male
CN-1	58	2	l/conn(Main harness-Frame harness)	S813-030200	S813-130200
CN-2	AMP	15	l/conn(Frame harness-Main harness)	2-85262-1	368301-1
CN-3	AMP	15	l/conn(Main harness-Frame harness)	2-85262-1	368301-1
CN-4	SWP	12	l/conn(Frame harness-Engine harness)	S816-012002	S816-112002
CN-5	AMP	15	l/conn(Main harness-Cab harness)	2-85262-1	368301-1
CN-6	AMP	15	l/conn(Main harness-Frame harness)	2-85262-1	368301-1
CN-8	SWP	12	l/conn(Main harness-Front harness)	S816-012002	S816-112002
CN-10	SWP	12	l/conn(Front harness-Main harness)	S816-012002	S816-112002
CN-11	DEUTSCH	8	l/conn(Main harness-Aircon harness)	DT06-8S	-
CN-12	AMP	15	l/conn(Frame harness-Engine harness)	2-85262-1	368301-1
CN-14	AMP	15	l/conn(Frame harness-Main harness)	2-85262-1	368301-1
CN-20	Molex	2	Horn	36825-0211	-
CN-21	HW090 sealed	6	Front wiper motor	6189-01330	-
CN-22	SWP	2	Front washer tank	S814-002000	-
CN-23	YAZAK1	2	Speaker(LH)	7123-1520	-
CN-24	YAZAK1	2	Speaker(RH)	7123-1520	-
CN-25	Molex	2	Horn	36825-0211	-
CN-26	250	2	Warning buzzer	S810-002202	-
CN-27	PA	9	Cassette and radio	S811-009003	-
CN-28	-	1	Comp(Air-con)	NMWP01F-B	-
CN-29	KET	2	Receiver drier	MG640795	-
CN-45	Ring term	-	Starter	S820-414000	-
CN-51	AMP	20	Cluster	174047-2	-
CN-52	AMP	68	T/M Control unit	962175	-
CN-53	-	6	Diagnostic	-	1-408705-0
CN-58	Econo seal III	36	Controller	344111-1	-
CN-60	58	2	Fusible link	-	S813-130200
CN-65	J	2	Back up buzzer	DT06-2S	-
CN-71	J	2	Parking solenoid	DT06-2S	-
CN-74	Ring term	-	Alternator	S820-105000	-
CN-75	AMP	2	Fan clutch	85202-1	-
CN-83	KET	2	Aircon fan	MG651092	-
CN-93	-	50	ECM	DRC26-50S-05	-
CN-96	PACKARD	2	Fuel heater	1530-0027	-

Connector number	Type	No. of pin	Destination	Connector part No.	
				Female	Male
CN-100	Autonics	-	Boom kick out	21L6-20020	-
CN-101	Autonics	-	Bucket leveler	21L6-20020	-
CN-102	HW090 sealed	6	Rear wiper motor	6189-01330	-
CN-103	SWP	2	Rear washer tank	S814-002000	-
CN-110	-	2	Joy stick	1-480698-0	-
CN-111	-	8	Joystick	S814-002000	-
CN-112	-	16	Gear box	21L7-60290	1201-0974
CN-114	-	6	Joy stick	1-480704-0	-
CN-121	PACKARD	4	Gear shift lever	-	-
CN-122	PACKARD	4	Gear shift lever	1201-5797	-
CN-136	-	2	Ride control valve	DT06-2S-P012	-
CN-137	-	2	Ride control solenoid	DT06-2S-P012	DT04-2P
CN-138	DEUTSCH	3	DC/DC Converter	DT06-3S	-
CN-139	DEUTSCH	2	12V socket	-	-
CN-144	J	6	Pedal	S816-006002	-
Relay					-
CR-1	Ring term	-	Battery relay	S820-104000	-
CR-2	250	4	Horn relay	S810-004202	-
CR-3	250	4	Front work lamp relay	S810-004202	-
CR-4	250	6	Wiper relay	S810-006202	-
CR-5	250	2	Safety relay	S810-006202	-
CR-6	250	4	Rear work lamp relay	S810-004202	-
CR-7	250	4	Aircon relay	S810-004202	-
CR-11	250	3	Flasher unit	S810-003702	-
CR-23	J	2	Start relay	-	S814-102001
CR-24	-	1	Preheater relay	S822-014000	-
CR-30	250	4	Back-up relay	S810-004202	-
CR-35	250	4	Ride control relay	S810-004202	-
CR-42	250	4	Preheater relay	S810-004202	-
CR-46	250	4	Fuel warmer relay	S810-004202	-
Switch					-
CS-1	-	1	Door switch	S822-014004	-
CS-2	SWP	6	Start key switch	S814-006000	-
CS-3	SWF	10	Rear wiper switch	593757	-
CS-5	Shur	1	Horn switch	S822-014000	-
CS-11	SWP	8	Multi function switch	S814-008000	-
CS-12	SWP	6	Multi function switch	S814-006000	-

Connector number	Type	No. of pin	Destination	Connector part No.	
				Female	Male
CS-17	SWF	10	Parking switch	593757	-
CS-20	SWF	10	Work lamp switch	593757	-
CS-23	SWF	10	Beacon switch	593757	-
CS-34	SWF	10	Buzzer stop switch	593757	-
CS-39	SWF	10	Main light switch	593757	-
CS-41	SWF	10	Hazard switch	593757	-
CS-42	SWF	10	Clutch cut off switch	593757	-
CS-50	SWF	10	Ride control switch	593757	-
CS-51	SWF	10	Auto/manual switch	593757	-
CS-53	SWF	10	Steering pump switch	593757	-
CS-55	-	1	Door switch	S822-014004	-
Light					
CL-1	-	2	Room lamp	MG610392	-
CL-2	250	3	Cigar lighter	S810-001202	-
CL-3	SWP	4	Head light(LH)	S814-004000	-
CL-4	SWP	4	Head light(RH)	S814-004000	-
CL-5	AMP	2	Work light(LH)	-	DT04-2P
CL-6	AMP	2	Work light(RH)	-	DT04-2P
CL-7	250	1	Beacon lamp	S810-001202	-
CL-15	SWP	4	Combi lamp(RR, LH)	S814-004000	-
CL-16	SWP	4	Combi lamp(RR, RH)	S814-004000	-
CL-21	-	1	Numberplate lamp	170183-2	-
CL-22	DEUTSCH	2	Work light(LH)	DT04-2P	-
CL-23	DEUTSCH	2	Work light(RH)	-	DT04-2P
CL-24	SWP	2	Turn lamp(LH)	S814-002000	-
CL-25	SWP	2	Turn lamp(RH)	S814-002000	-
Sensor, sender					
CD-1	AMP	2	Hydraulic oil temp sensor	85202-1	-
CD-2	SWP	2	Fuel sensor	S814-002000	-
CD-3	Rubber cap	-	Brake fail pressure switch	21EA-003100	-
CD-4	Rubber cap	-	Stop lamp pressure switch	21EA-003100	-
CD-5	Rubber cap	-	Clutch cut off pressure switch	21EA-003100	-
CD-10	Ring term	2	Air cleaner switch	S820-105000	-
CD-15	AMP	2	Converter sensor	85202-1	-
CD-17	AMP	2	Engine pick-up sensor	85202-1	-
CD-26	Rubber cap	-	Parking pressure switch	21EA-003100	-
CD-27	AMP	2	Turbin pick up sensor	85202-1	-

Connector number	Type	No. of pin	Destination	Connector part No.	
				Female	Male
CD-35	PACKARD	2	Fuel filter	1204-0753	-
CD-39	Rubber cap	-	Steering pressure switch	21EA-00310	-
CD-40	Rubber cap	2	Steering pump pressure switch	21EA-00310	-
CD-50	AMP	2	Gear chain sensor	85202-1	-
CD-51	-	3	Output speed sensor	282087	-
CD-52	AMP	2	Oil filter	282080	-

2. CONNECTION TABLE FOR CONNECTORS

1) 58-L TYPE CONNECTOR

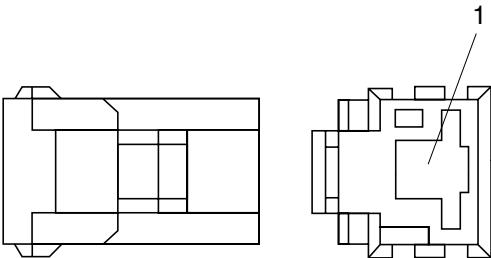
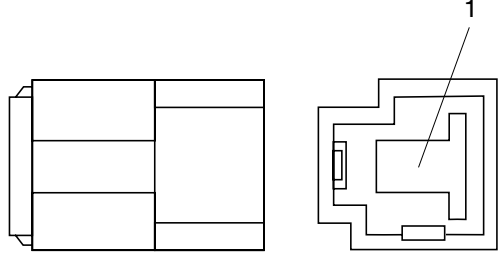
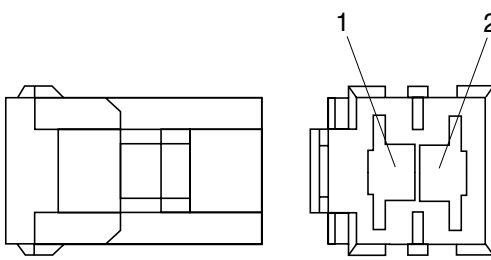
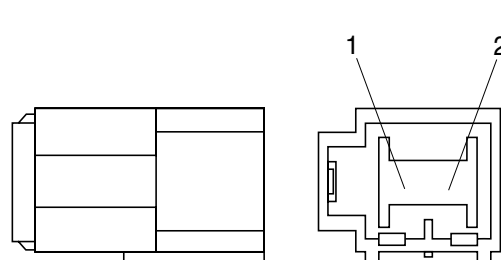
No. of pin	Receptacle connector(Female)	Plug connector(Male)
1	 <p data-bbox="683 723 834 757">S813-030100</p>	 <p data-bbox="1257 723 1409 757">S813-130100</p>
2	 <p data-bbox="683 1131 834 1164">S813-030200</p>	 <p data-bbox="1257 1131 1409 1164">S813-130200</p>

2) PA TYPE CONNECTOR

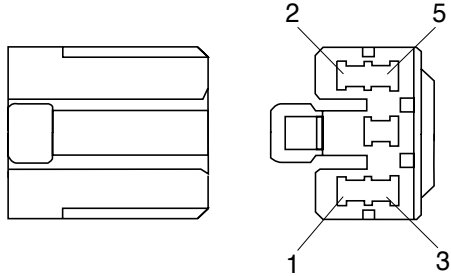
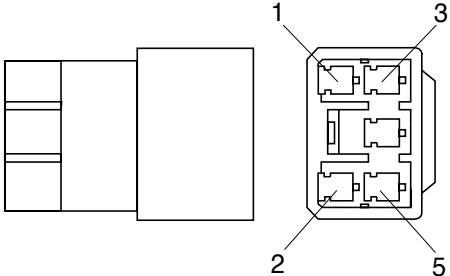
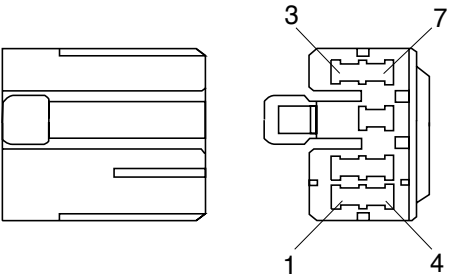
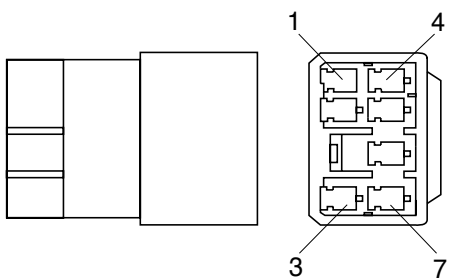
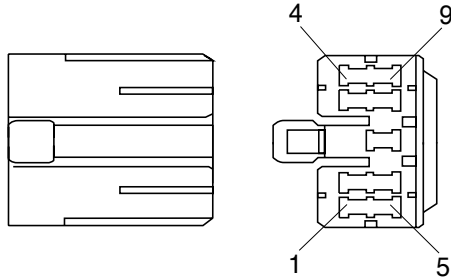
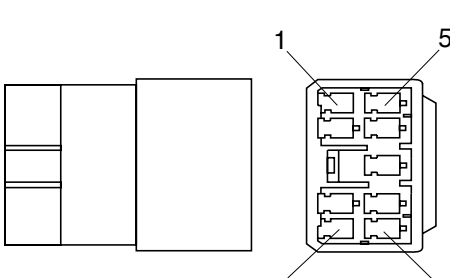
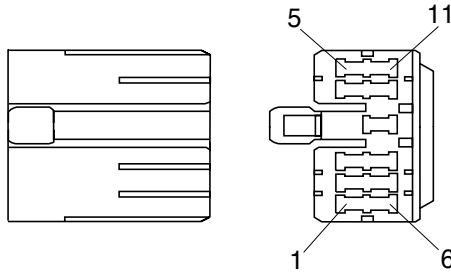
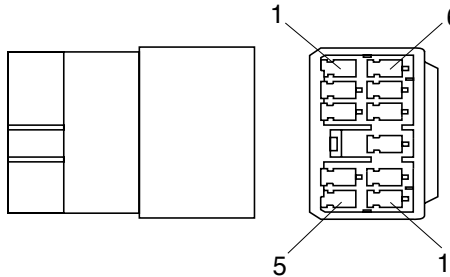
No. of pin	Receptacle connector(Female)	Plug connector(Male)
5	 <p data-bbox="683 667 831 696">S811-005002</p>	 <p data-bbox="1257 667 1406 696">S811-105002</p>
7	 <p data-bbox="683 1077 831 1106">S811-007002</p>	 <p data-bbox="1257 1077 1406 1106">S811-107002</p>
9	 <p data-bbox="683 1485 831 1514">S811-009002</p>	 <p data-bbox="1257 1485 1406 1514">S811-109002</p>
11	 <p data-bbox="683 1892 831 1921">S811-011002</p>	 <p data-bbox="1257 1892 1406 1921">S811-111002</p>

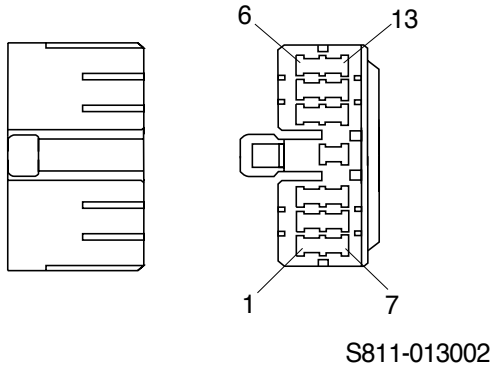
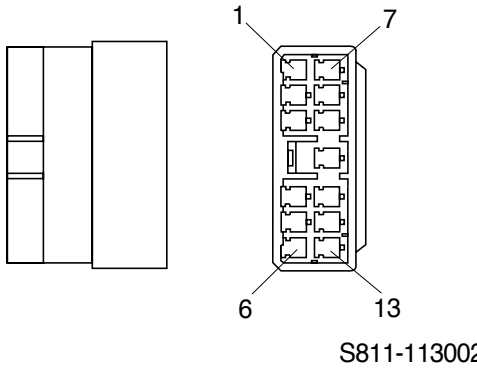
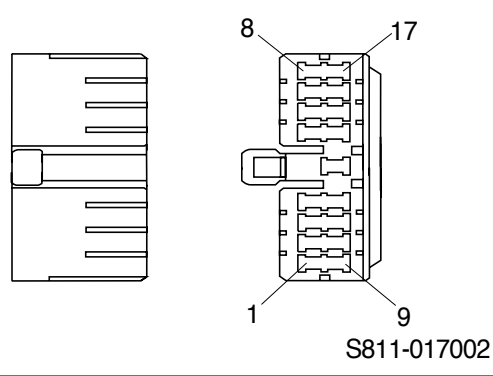
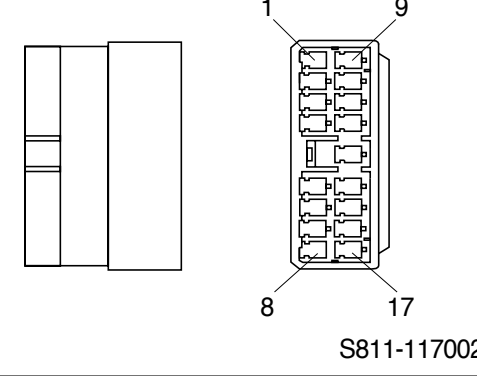
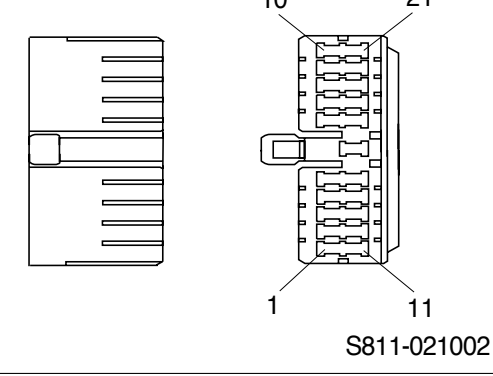
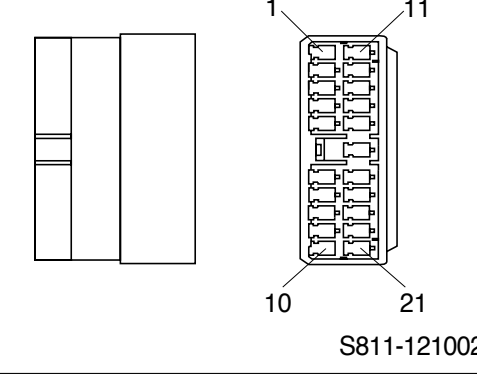
No. of pin	Receptacle connector(Female)	Plug connector(Male)
13	 <p style="text-align: center;">S811-013002</p>	 <p style="text-align: center;">S811-113002</p>
17	 <p style="text-align: center;">S811-017002</p>	 <p style="text-align: center;">S811-117002</p>
21	 <p style="text-align: center;">S811-021002</p>	 <p style="text-align: center;">S811-121002</p>

3) J TYPE CONNECTOR

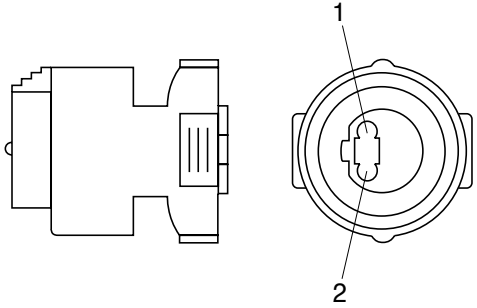
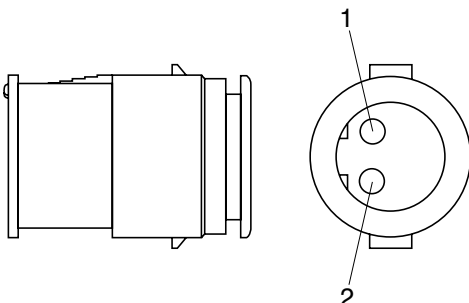
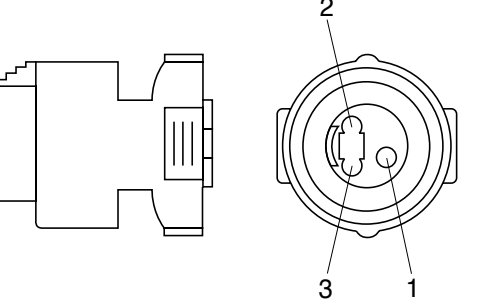
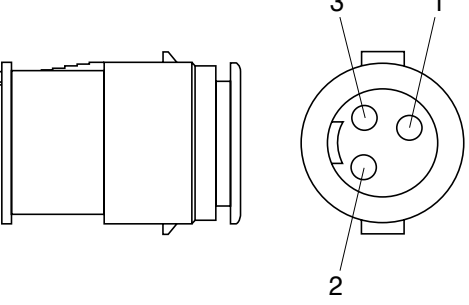
No. of pin	Receptacle connector(Female)	Plug connector(Male)
2	 <p data-bbox="686 672 829 705">S816-002001</p>	 <p data-bbox="1260 672 1404 705">S816-102001</p>
3	 <p data-bbox="686 1075 829 1108">S816-003001</p>	 <p data-bbox="1260 1075 1404 1108">S816-103001</p>

4) SWP TYPE CONNECTOR

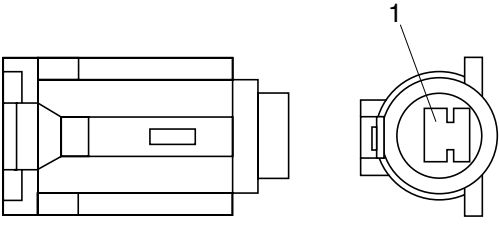
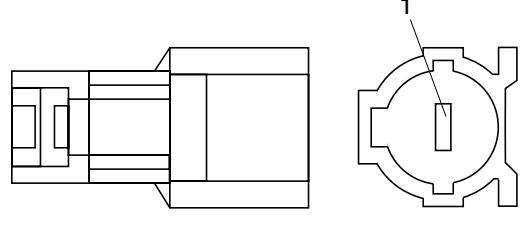
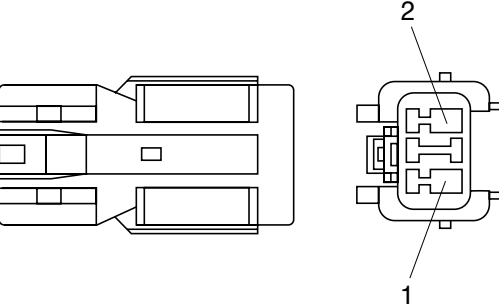
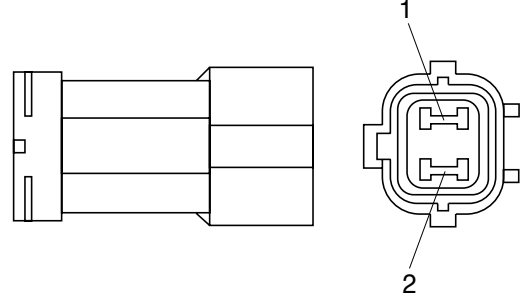
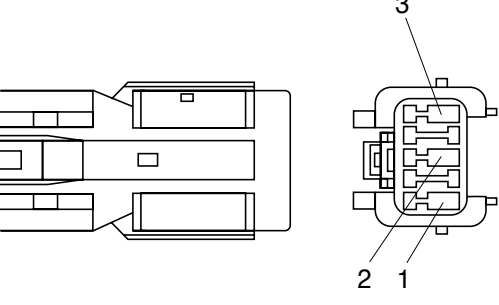
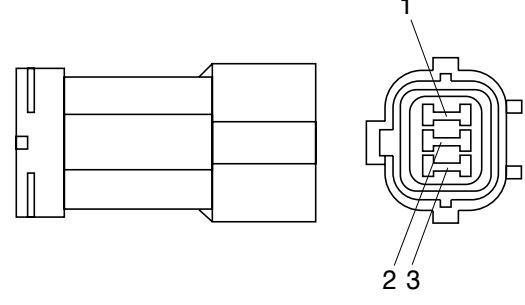
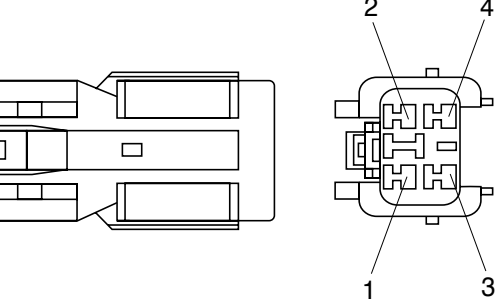
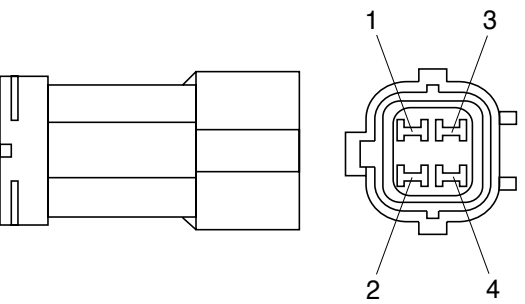
No. of pin	Receptacle connector(Female)	Plug connector(Male)
1	 <p data-bbox="686 672 837 705">S814-001000</p>	 <p data-bbox="1260 672 1412 705">S814-101000</p>
2	 <p data-bbox="686 1075 837 1108">S814-002000</p>	 <p data-bbox="1260 1075 1412 1108">S814-102000</p>
3	 <p data-bbox="686 1478 837 1512">S814-003000</p>	 <p data-bbox="1260 1478 1412 1512">S814-103000</p>
4	 <p data-bbox="686 1892 837 1926">S814-004000</p>	 <p data-bbox="1260 1892 1412 1926">S814-104000</p>

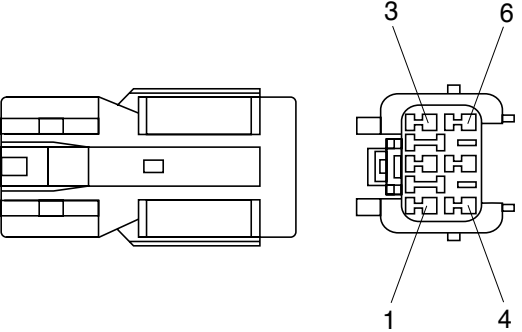
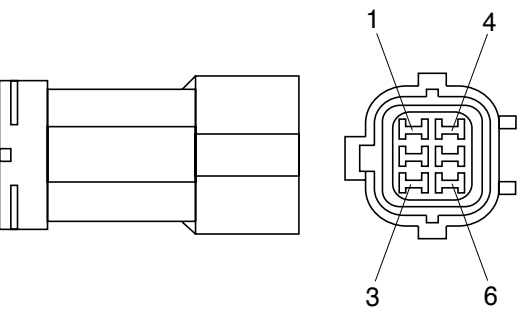
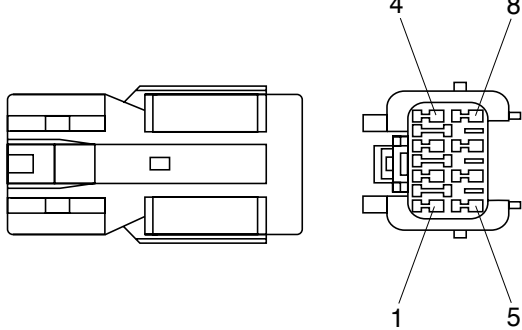
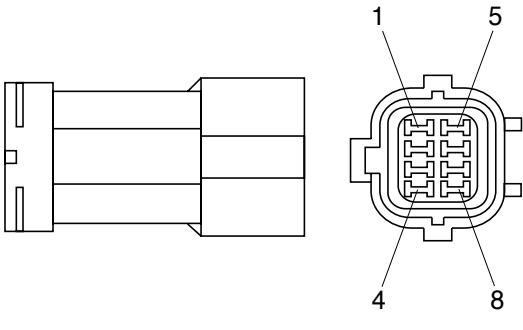
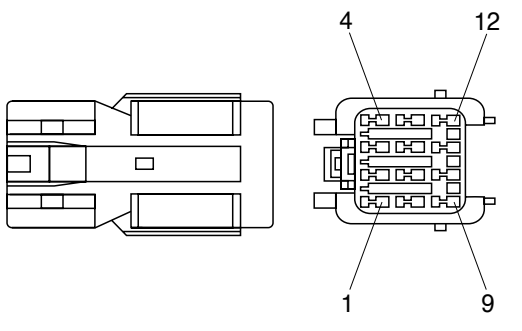
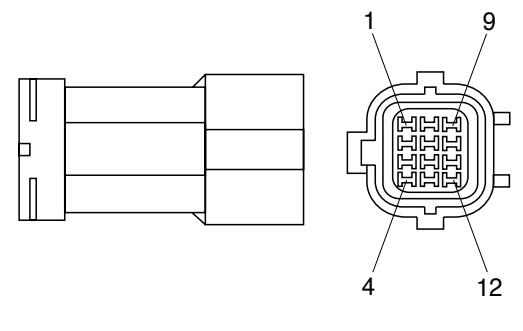
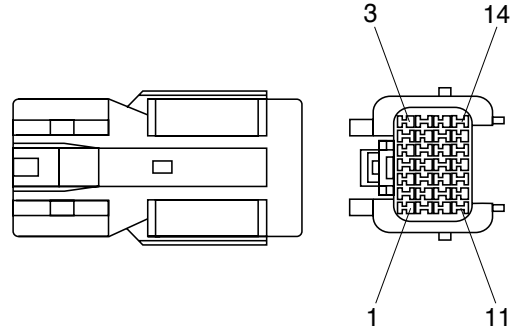
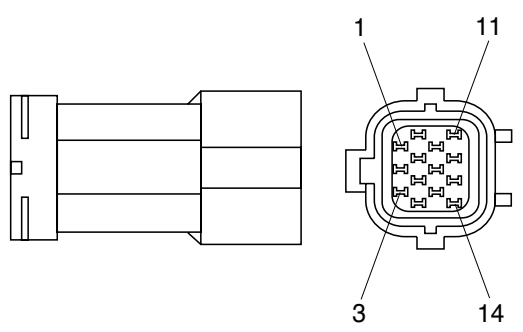
No. of pin	Receptacle connector(Female)	Plug connector(Male)
6	 <p data-bbox="687 629 836 658">S814-006000</p>	 <p data-bbox="1262 629 1410 658">S814-106000</p>
8	 <p data-bbox="687 1037 836 1066">S814-008000</p>	 <p data-bbox="1262 1037 1410 1066">S814-108000</p>
12	 <p data-bbox="687 1444 836 1473">S814-012000</p>	 <p data-bbox="1262 1444 1410 1473">S814-112000</p>
14	 <p data-bbox="687 1852 836 1881">S814-014000</p>	 <p data-bbox="1262 1852 1410 1881">S814-114000</p>

5) CN TYPE CONNECTOR

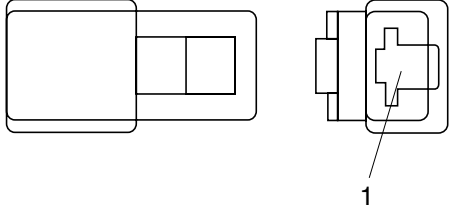
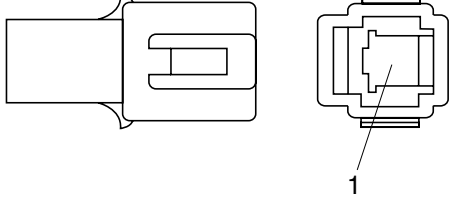
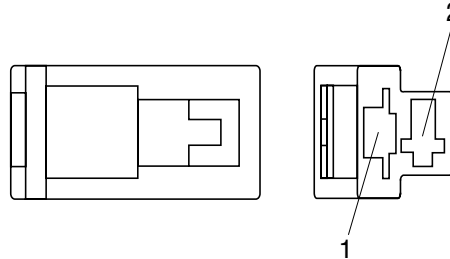
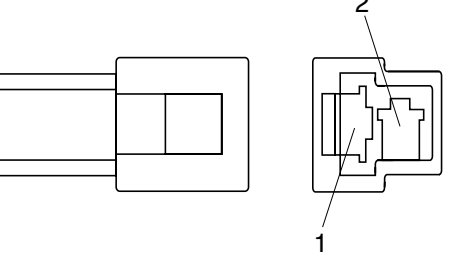
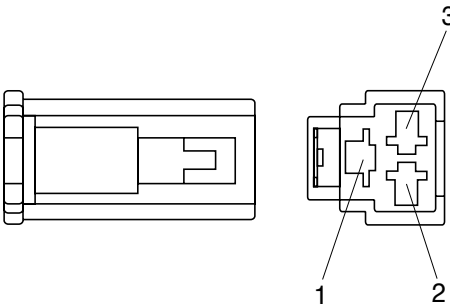
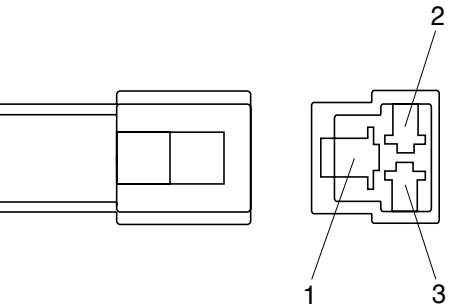
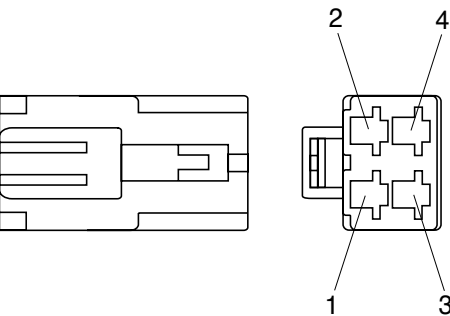
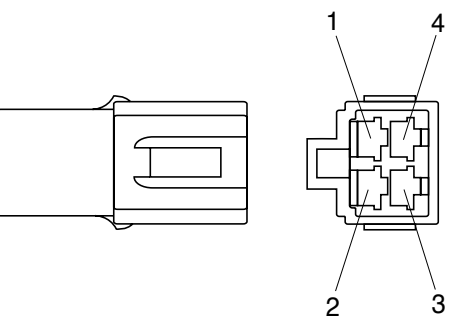
No. of pin	Receptacle connector(Female)	Plug connector(Male)
1	 <p data-bbox="687 674 839 707">S810-001202</p>	 <p data-bbox="1262 674 1414 707">S810-101202</p>
2	 <p data-bbox="687 1077 839 1111">S810-002202</p>	 <p data-bbox="1262 1077 1414 1111">S810-102202</p>
3	 <p data-bbox="687 1480 839 1514">S810-003202</p>	 <p data-bbox="1262 1480 1414 1514">S810-103202</p>
4	 <p data-bbox="687 1883 839 1917">S810-004202</p>	 <p data-bbox="1262 1883 1414 1917">S810-104202</p>

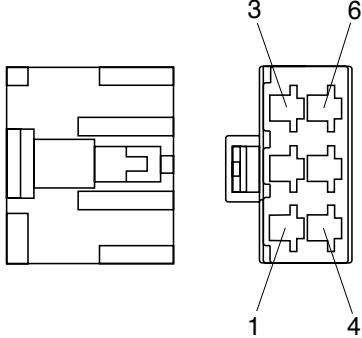
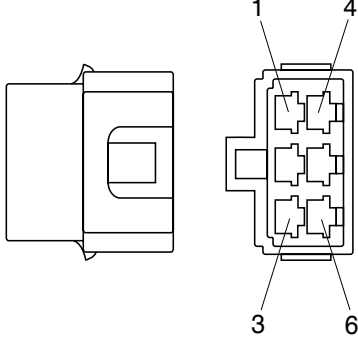
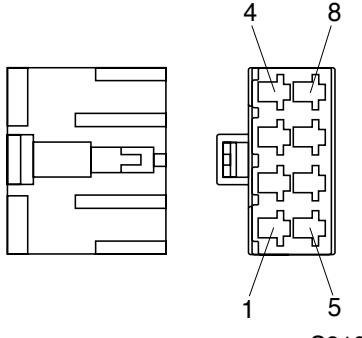
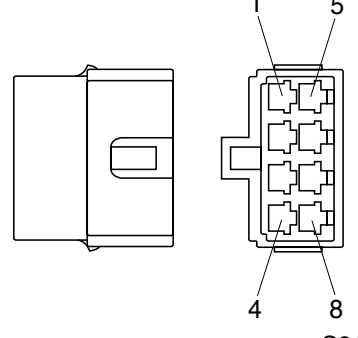
No. of pin	Receptacle connector(Female)	Plug connector(Male)
6	 <p data-bbox="686 627 837 660">S810-006202</p>	 <p data-bbox="1252 627 1404 660">S810-106202</p>
8	 <p data-bbox="686 1041 837 1075">S810-008202</p>	 <p data-bbox="1252 1041 1404 1075">S810-108202</p>

6) ITT SWF CONNECTOR

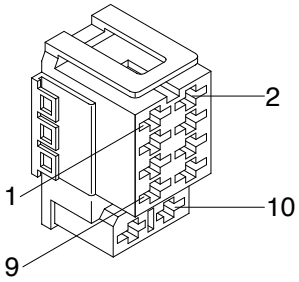
No. of pin	Receptacle connector(Female)	Plug connector(Male)
10	 <p style="text-align: right;">SWF593757</p>	

7) HW090 SEALED CONNECTOR

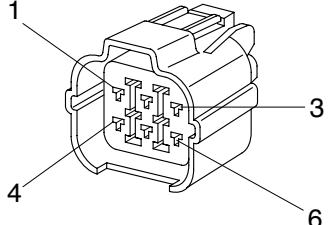
No. of pin	Receptacle connector(Female)	Plug connector(Male)
6	 <p style="text-align: right;">6189-0133</p>	

8) MWP02F-B CONNECTOR

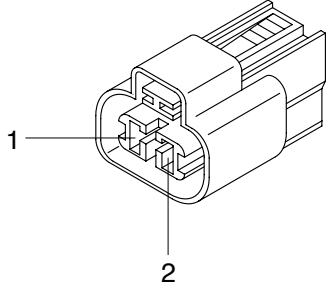
No. of pin	Receptacle connector(Female)	Plug connector(Male)
2	 <p style="text-align: right;">PH805-02028</p>	

9) AMP ECONOSEAL CONNECTOR

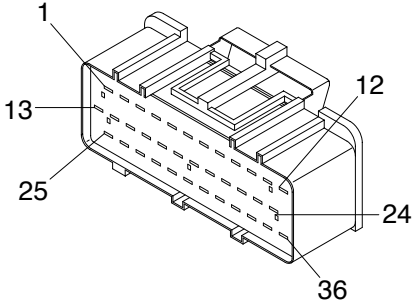
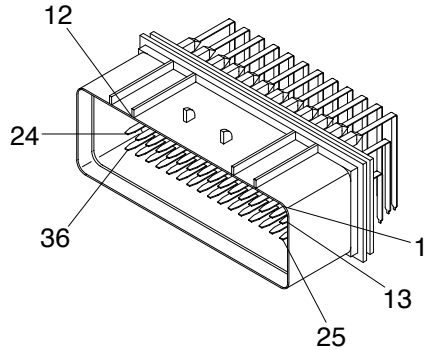
No. of pin	Receptacle connector(Female)	Plug connector(Male)
36	 <p style="text-align: right;">344111-1</p>	 <p style="text-align: right;">344108-1</p>

GROUP 6 TROUBLESHOOTING

1. WHEN STARTING SWITCH IS TURNED ON, CLUSTER LAMP DOES NOT LIGHT UP

- Before carrying out below procedure, check all the related connectors are properly inserted and the fuse No.26 is not blown out and ON/OFF of bulb.
- After checking, connect the disconnected connectors again immediately unless otherwise specified.

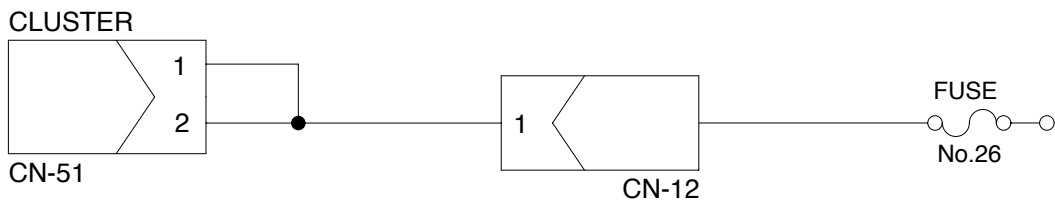
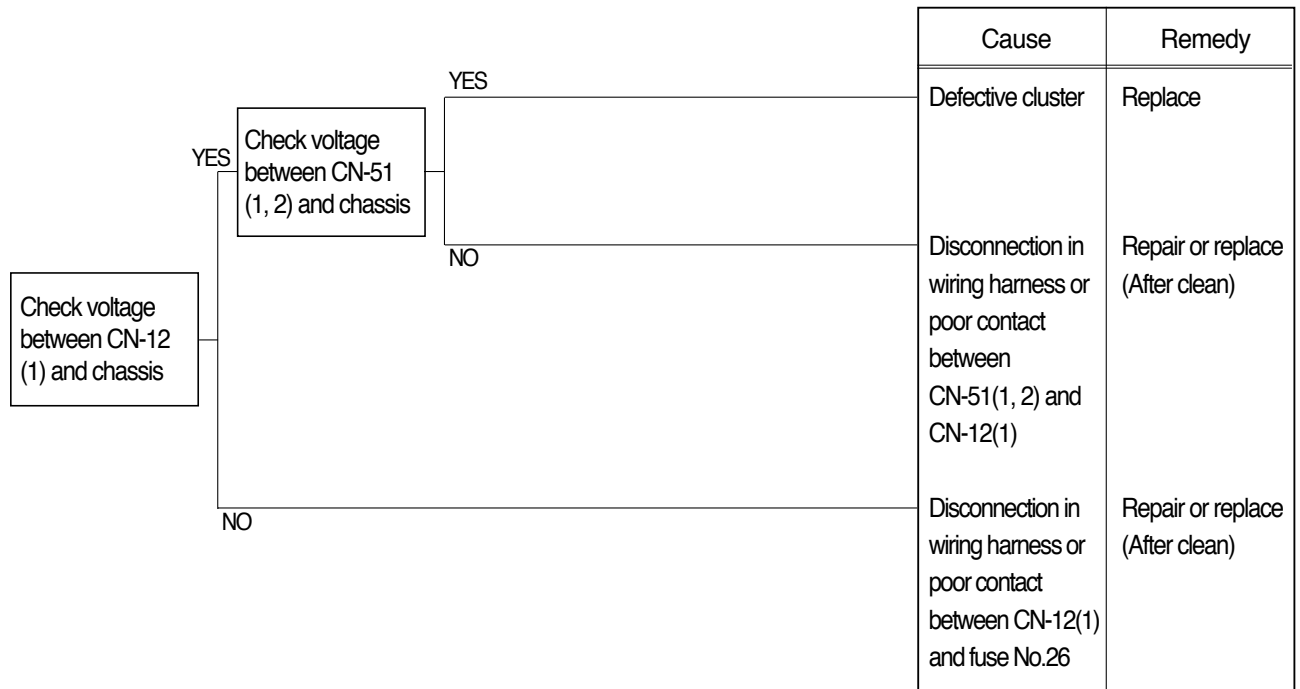

Check voltage

YES	20 ~ 30V
NO	0V

7607EL14

2. WHEN BATTERY LAMP LIGHTS UP (Engine is started)

- Before carrying out below procedure, check all the related connectors are properly inserted.
- After checking, connect the disconnected connectors again immediately unless otherwise specified.

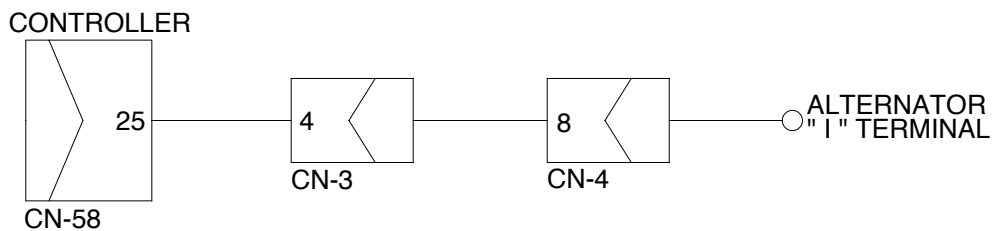
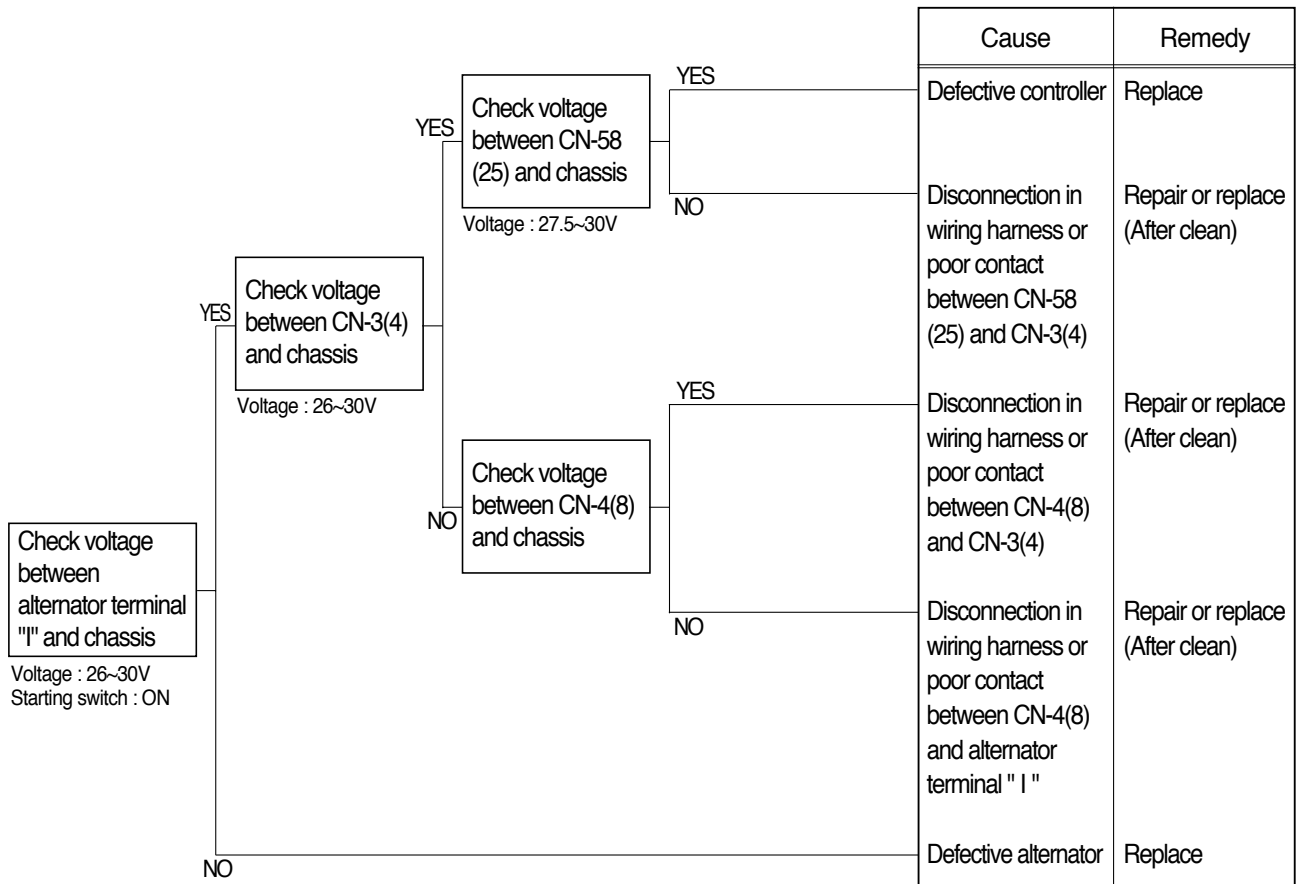

Check voltage

YES	20 ~ 30V
NO	0V

7707EL23

3. WHEN PARKING SOLENOID DOES NOT WORK

- Before carrying out below procedure, check all the related connectors are properly inserted and the fuse No.8 is not blown out.
- After checking, connect the disconnected connectors again immediately unless otherwise specified.

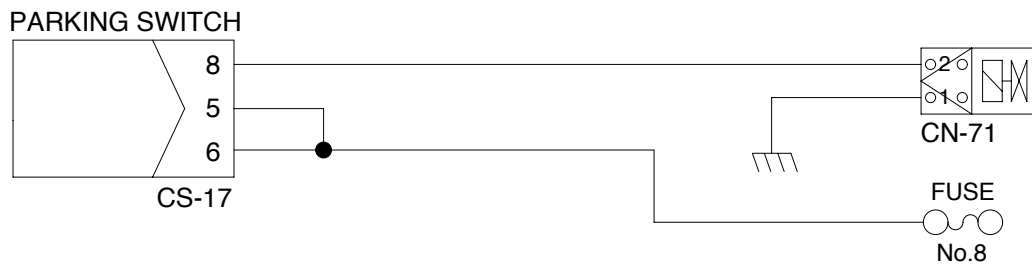
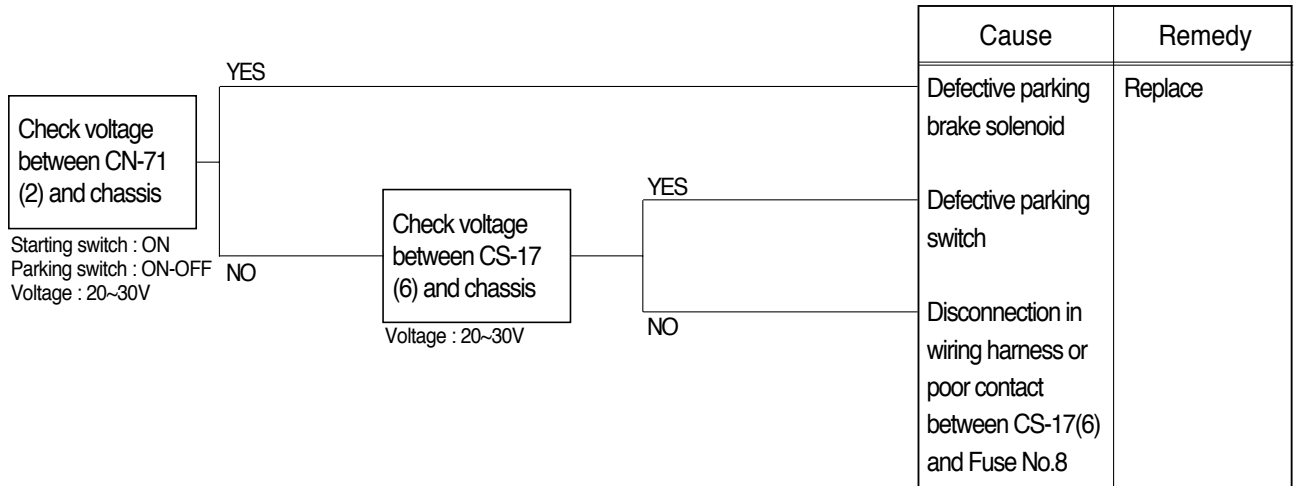

7707EL24

4. TRANSMISSION IS NOT RETURNED TO NEUTRAL WHEN PARKING BRAKE IS APPLIED

- Before carrying out below procedure, check all the related connectors are properly inserted and the fuse No.17(T/M controller) and No.8 are not blown out.
- After checking, connect the disconnected connectors again immediately unless otherwise specified.

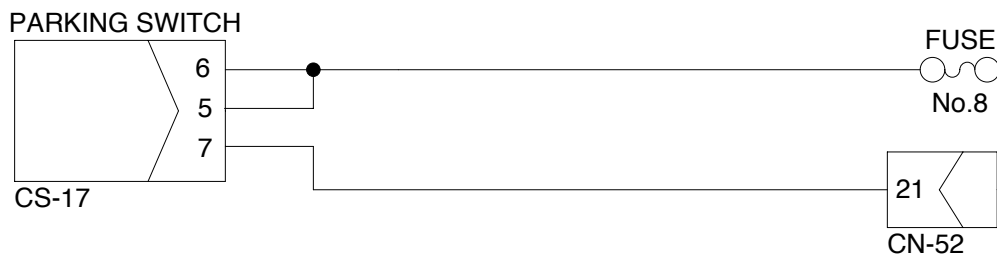
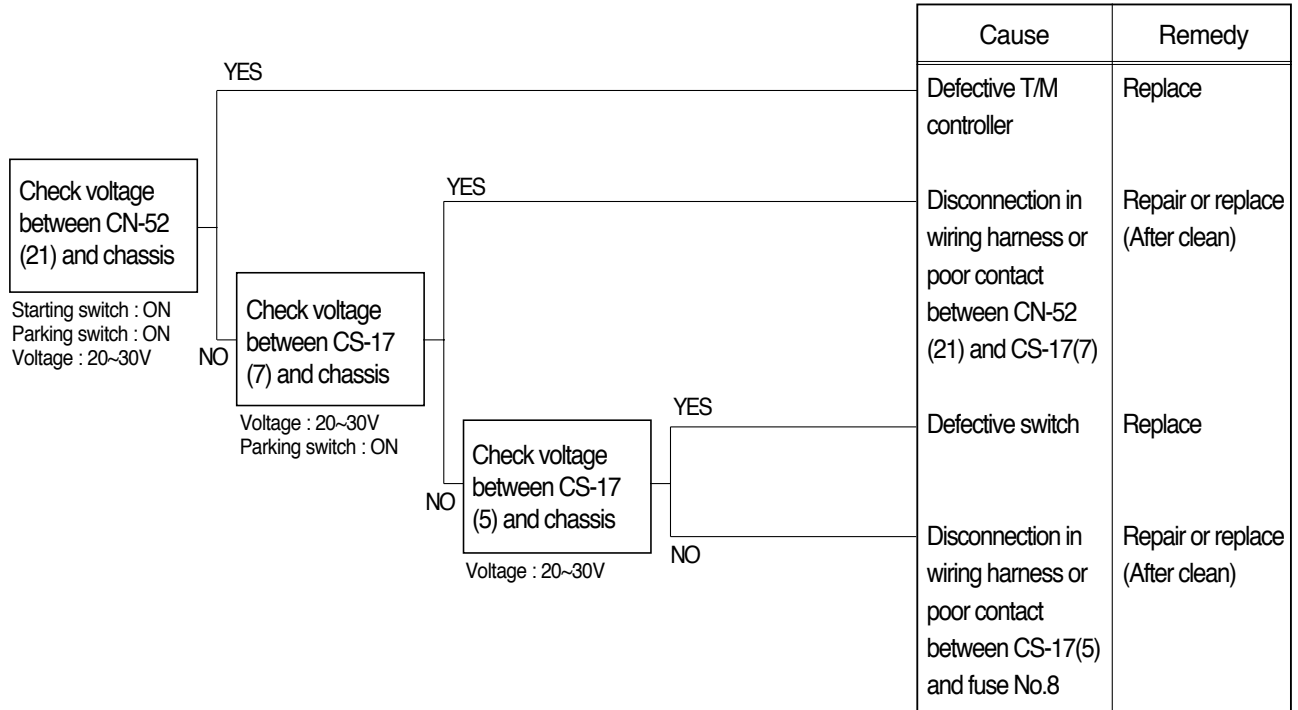

Check resistance

YES	MAX 1
NO	MIN 1M

7707EL25

5. MACHINE DOES NOT TRAVEL

- Before carrying out below procedure, check all the related connectors are properly inserted and the fuse No.17(Transmission controller) is not blown out.
- After checking, connect the disconnected connectors again immediately unless otherwise specified.
- Wiring diagram : **See page 7-16.**

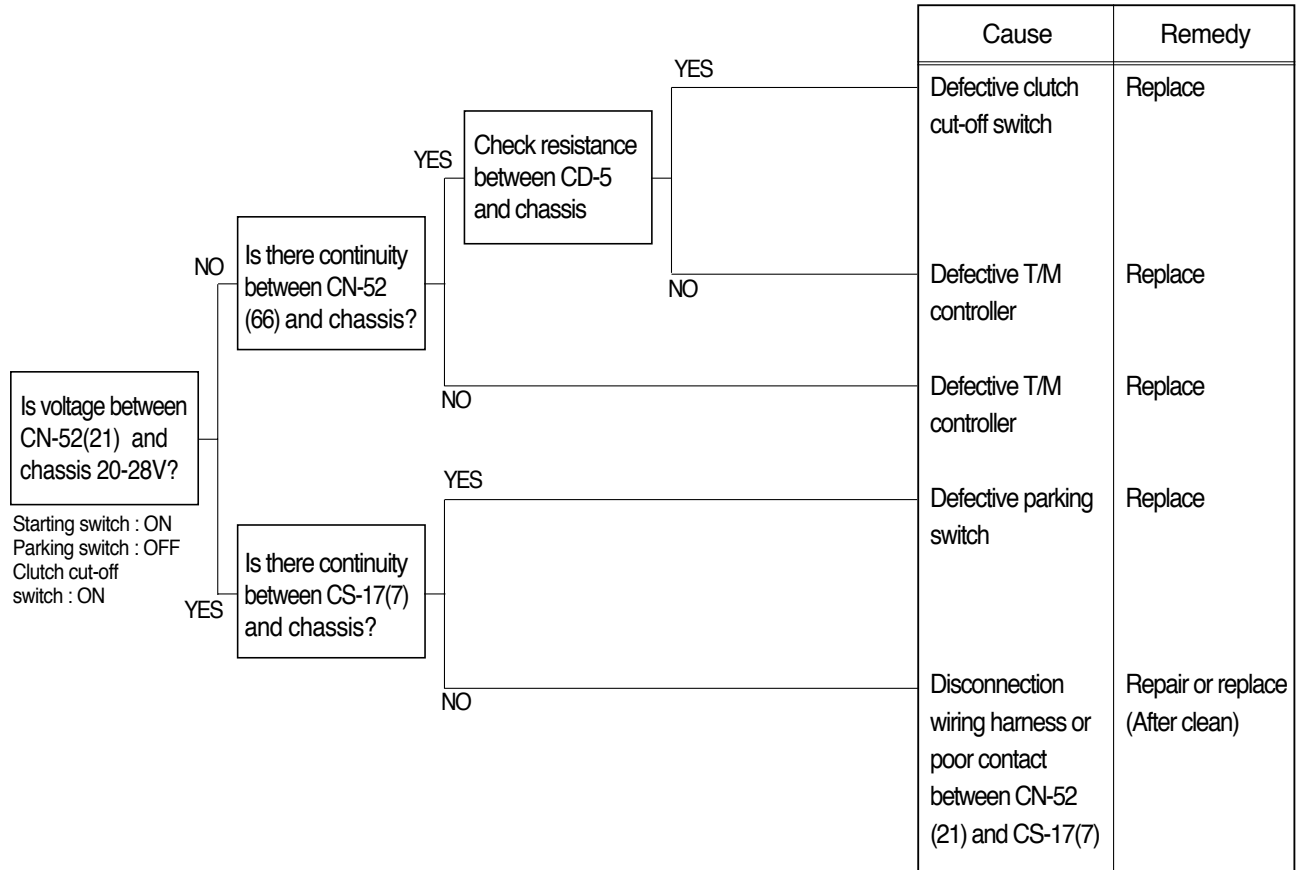

Check resistance

YES	MAX 1
NO	MIN 1M

6. WHEN STARTING SWITCH IS TURNED ON, WIPER MOTOR DOES NOT OPERATE

- Before carrying out below procedure, check all the related connectors are properly inserted and the fuse No.9 is not blown out.
- After checking, connect the disconnected connectors again immediately unless otherwise specified.

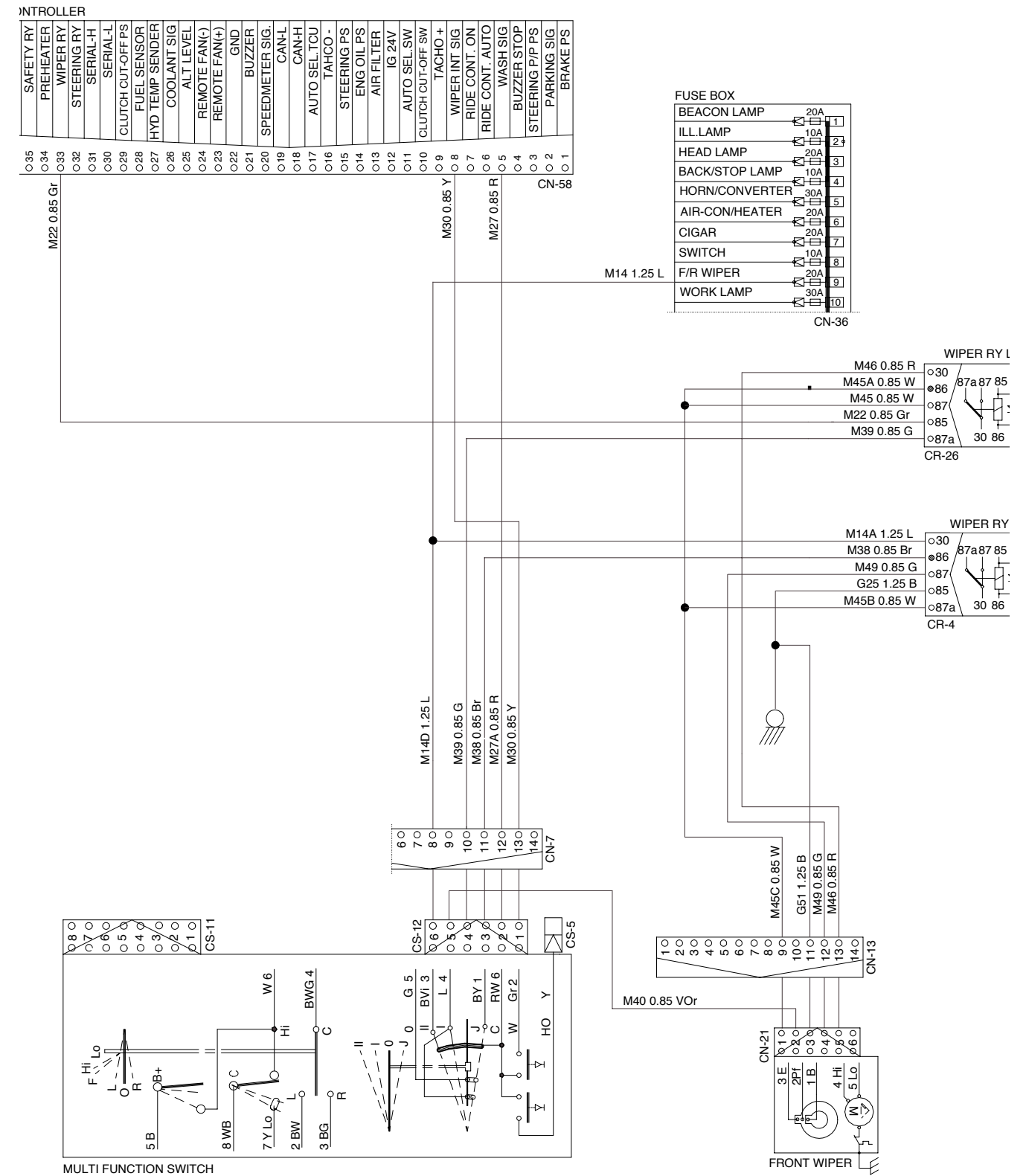
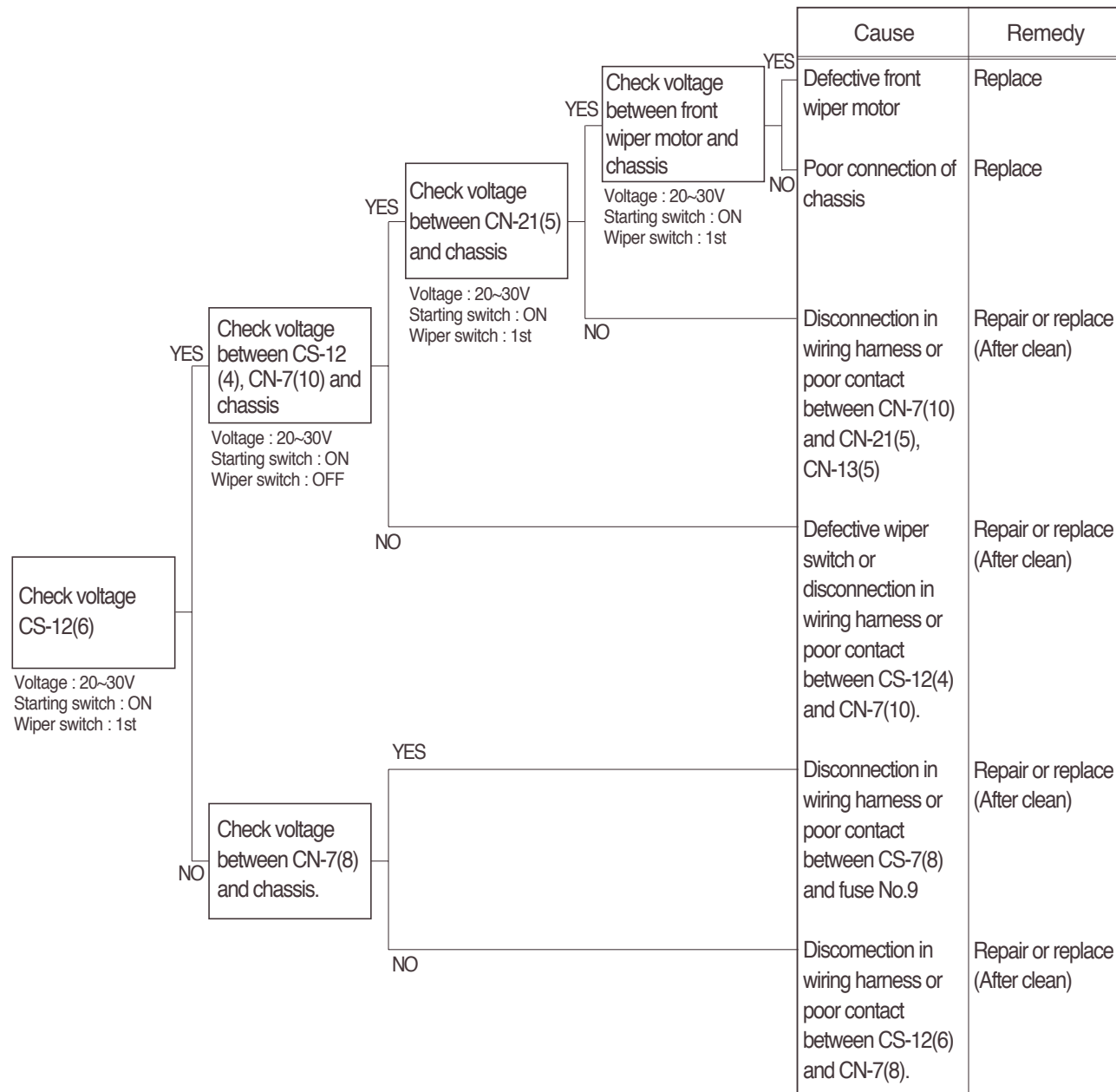

7. WHEN STARTING SWITCH "ON" DOES NOT OPERATE

- Before carrying out below procedure, check all the related connectors are properly inserted and and the fuse No.16 is not blown out.
- After checking, connect the disconnected connectors again immediately unless otherwise specified.

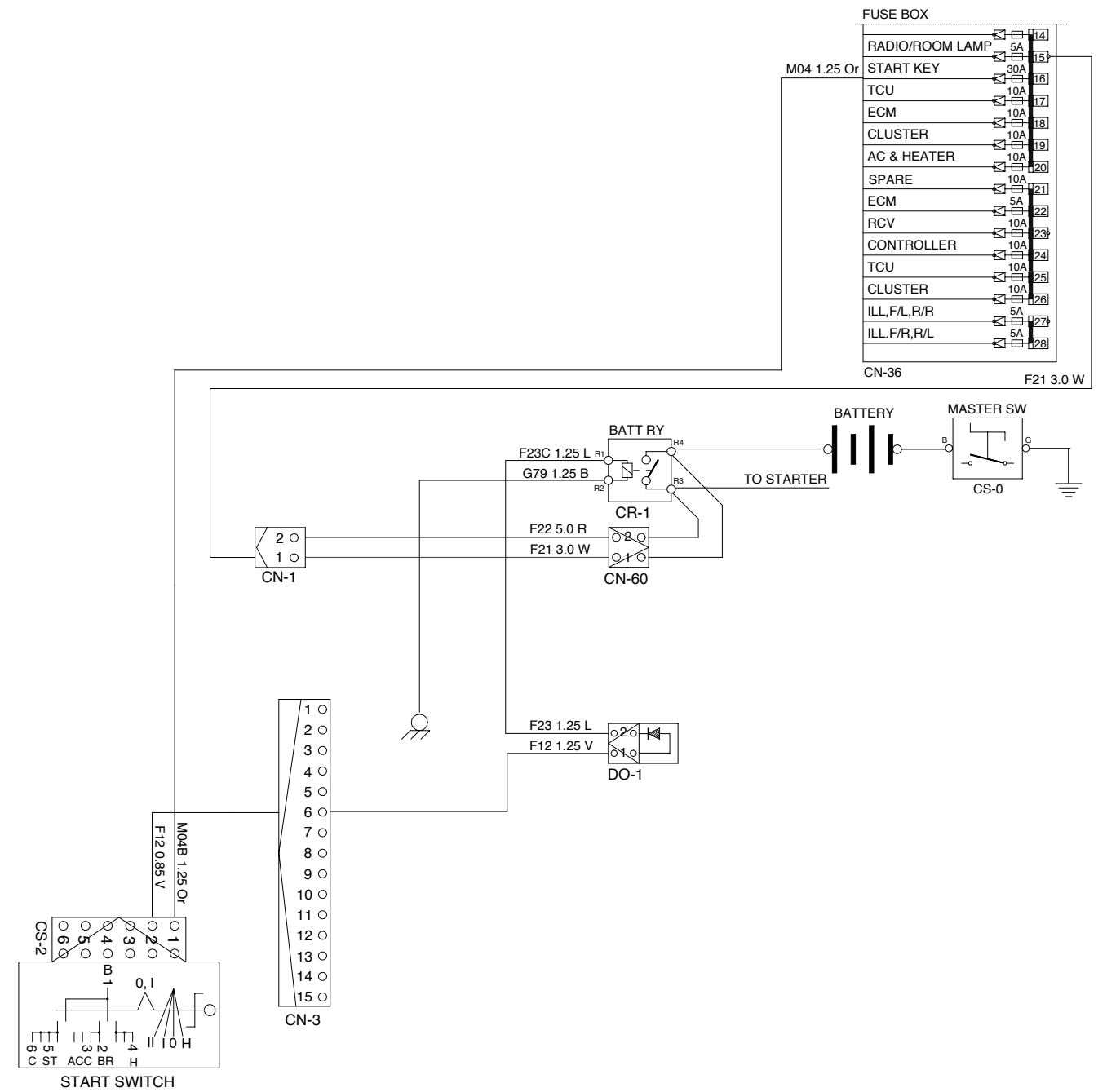
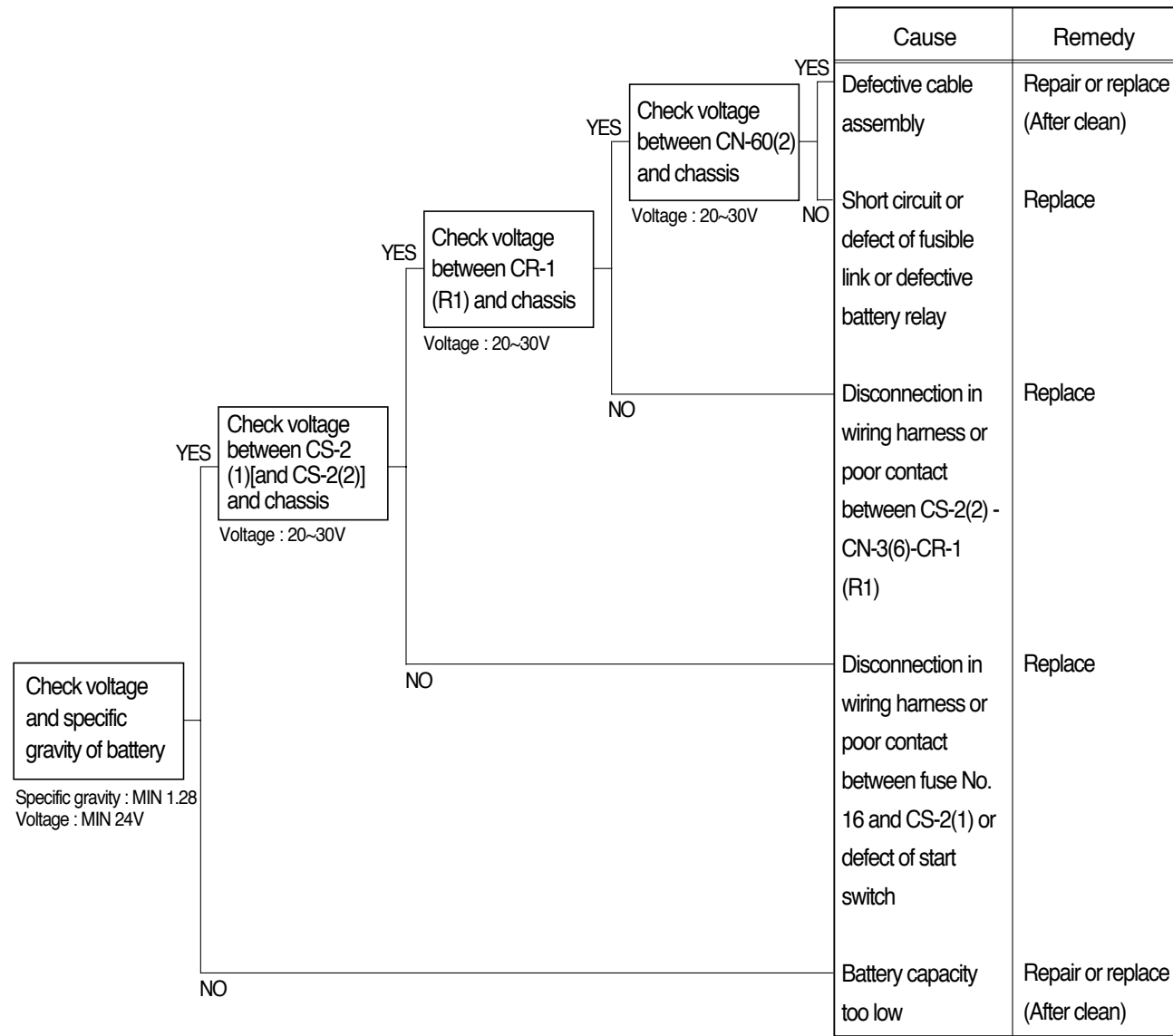

8. WHEN STARTING SWITCH IS TURNED ON, WORK LAMP DOES NOT LIGHTS UP

- Before carrying out below procedure, check all the related connectors are properly inserted, and the fuse No.10 is not blown out.
- After checking, connect the disconnected connectors again immediately unless otherwise specified.

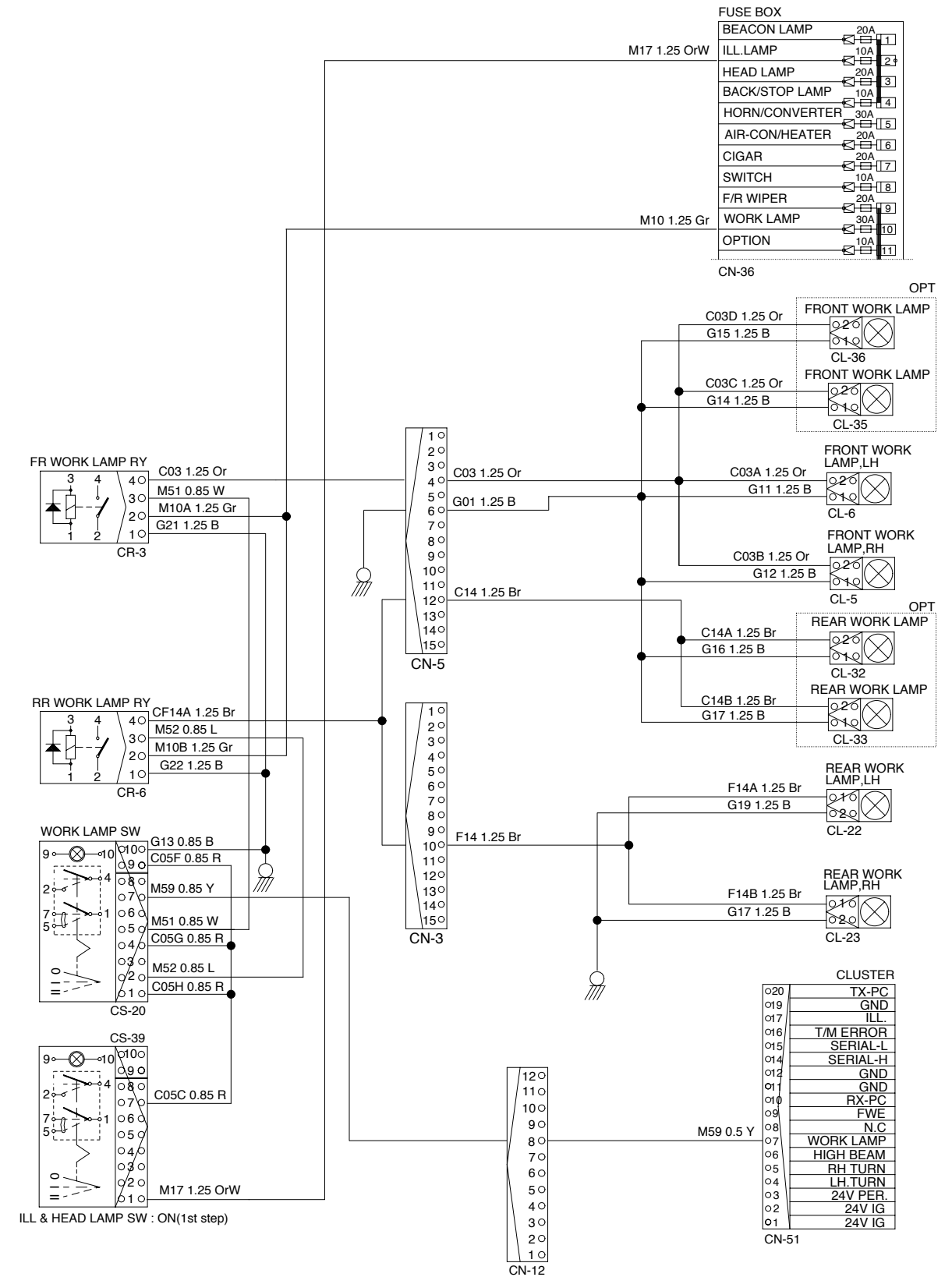
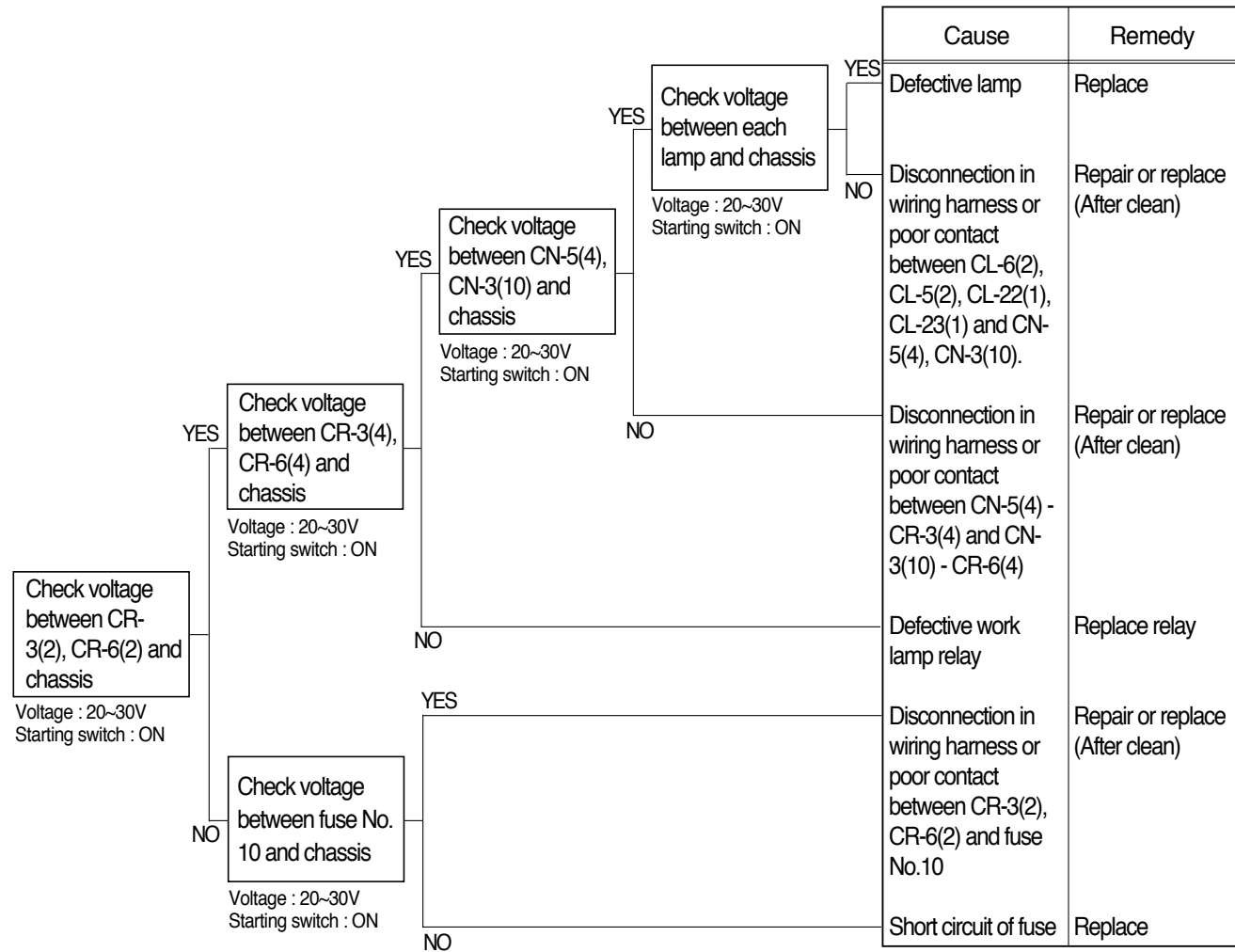

9. WHEN ENGINE DOES NOT START

- Check supply of the power at engine stop solenoid while starting switch is ON.
- Before carrying out below procedure, check all the related connectors are properly inserted.
- After checking, connect the disconnected connectors again immediately unless other wise specified.
- Check forward reverse switch at neutral position.

