

## SECTION 5 STEERING SYSTEM

Group 1 Structure and Function .....	5-1
Group 2 Operational Checks and Troubleshooting .....	5-17
Group 3 Tests and Adjustments .....	5-26
Group 4 Disassembly and Assembly .....	5-34

# SECTION 5 STEERING SYSTEM

## GROUP 1 STRUCTURE AND FUNCTION

### 1. OUTLINE

The steering system of this machine consists of a fixed-displacement pump supplying a load sensing steering system and an open center loader system.

The components of the steering system are :

- Steering pump
- Steering valve(EHPS)
- Steering unit
- Cushion valve
- Steering cylinders

The steering pump, the first pump of main pump, draws hydraulic oil from the hydraulic tank.

Outlet flow from the pump flows to the priority valve of steering valve. The of steering valve preferentially supplies flow, on demand, to the steering unit. When the machine is steered, the steering unit routes flow to the steering cylinders to articulate the machine.

When the machine is not being steered, or if pump flow is greater than steering flow, the priority valve supplies flow to the loader system.

That is, output flow from the steering pump enters into the second pump of main pump for the operation of the attachment.

## 2. HYDRAULIC CIRCUIT

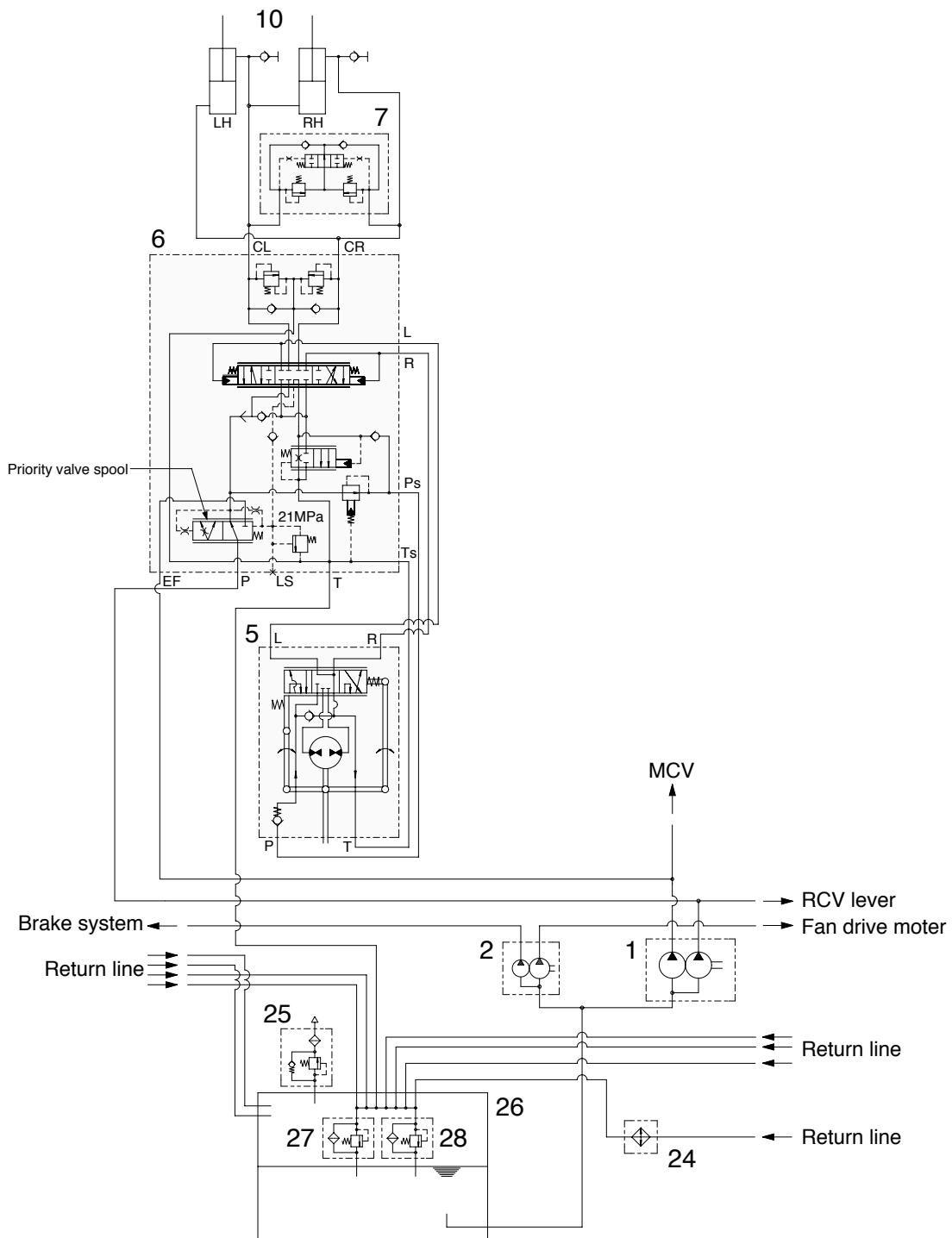

7607SE01

- |    |                      |    |                |
|----|----------------------|----|----------------|
| 1  | Main pump(Steering)  | 24 | Oil cooler     |
| 2  | Brake & fan pump     | 25 | Air breather   |
| 5  | Steering unit        | 26 | Hydraulic tank |
| 6  | Steering valve(EHPS) | 27 | Return filter  |
| 7  | Cushion valve        | 28 | Bypass valve   |
| 10 | Steering cylinder    |    |                |





### 3) RIGHT TURN

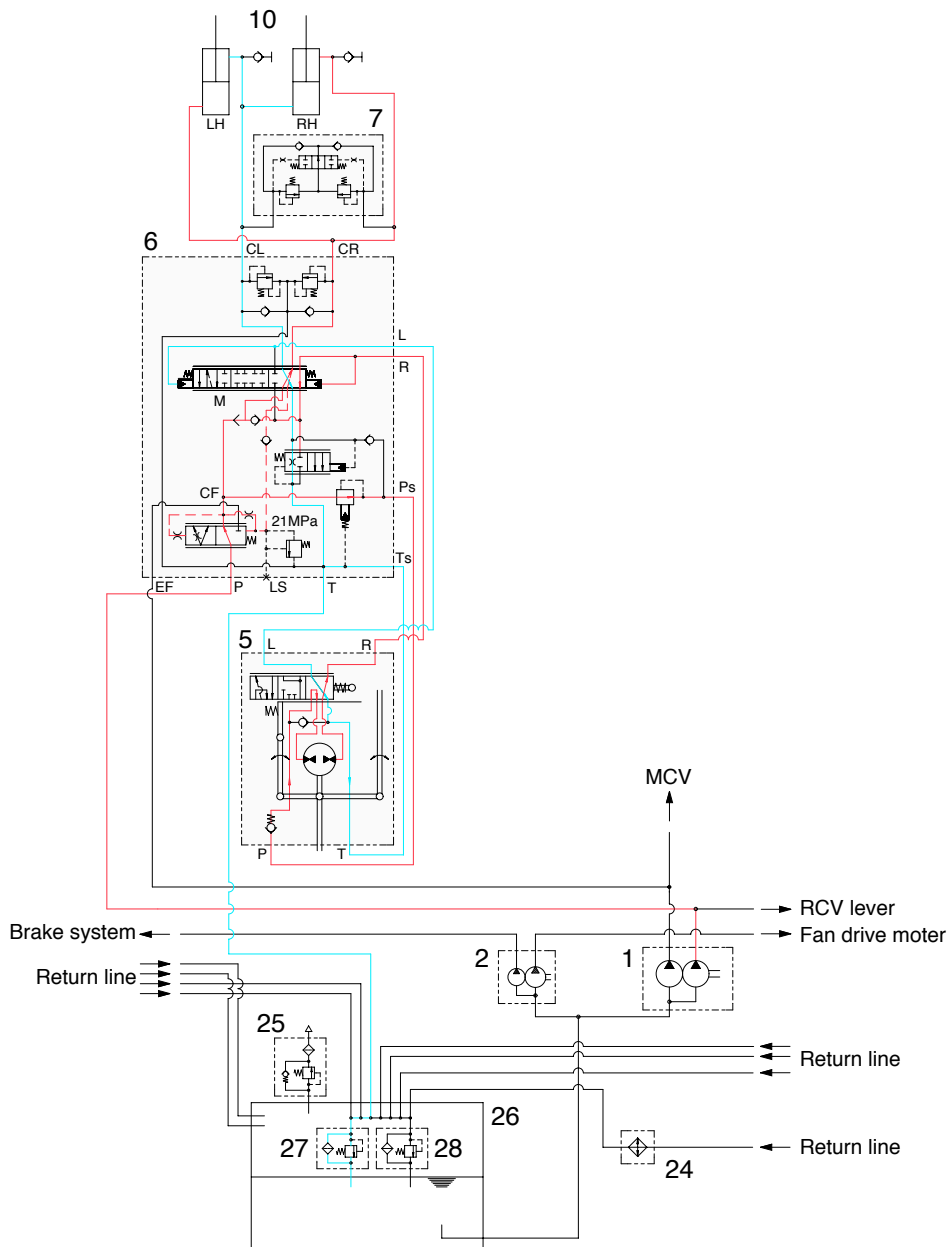

7607SE04

- When the steering wheel is turned to the right, the pressure oil from the steering unit fill on the right side chamber of main steering spool(M), and main steering spool moves to the left in the direction.
- At the same time of moving of main steering spool, LS signal will be blocked.
- If LS signal of main steering spool is blocked, it cause to increase pressure of left chamber of priority valve and then priority valve to be pushed to left side. Consequently, oil will flow via CF of priority valve to main spool. That oil will push steering cylinder rod out and it will cause wheel loader to be steered to right side.
- The rate of movement of main steering spool is concluded as flow rate, which is kept in right chamber from steering unit. Furthermore the rate controls speed of movement for cylinder.

### 3. STEERING VALVE(EHPS)

#### 1) STRUCTURE

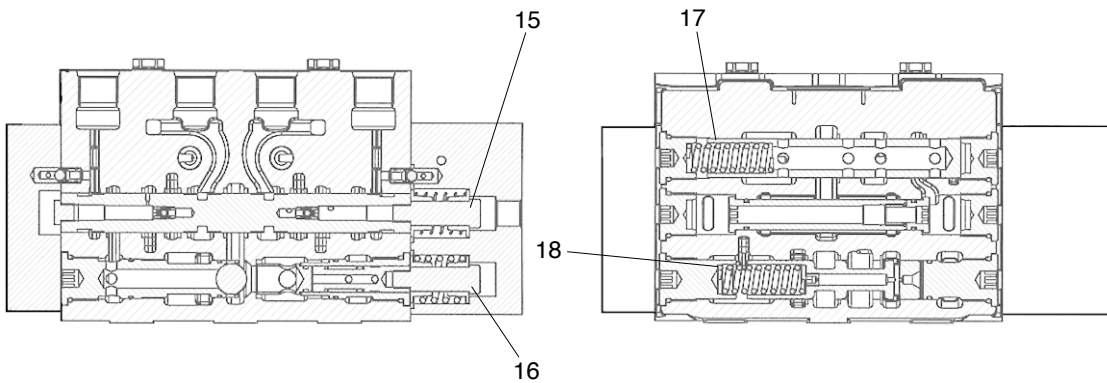
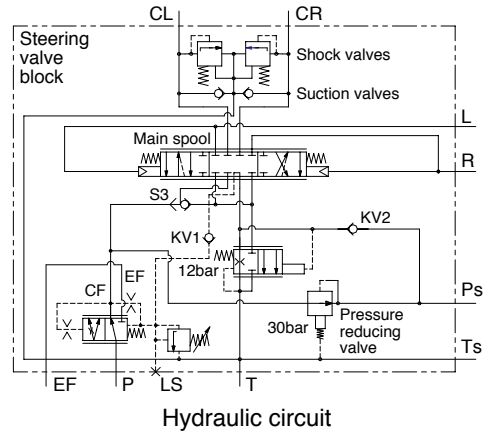
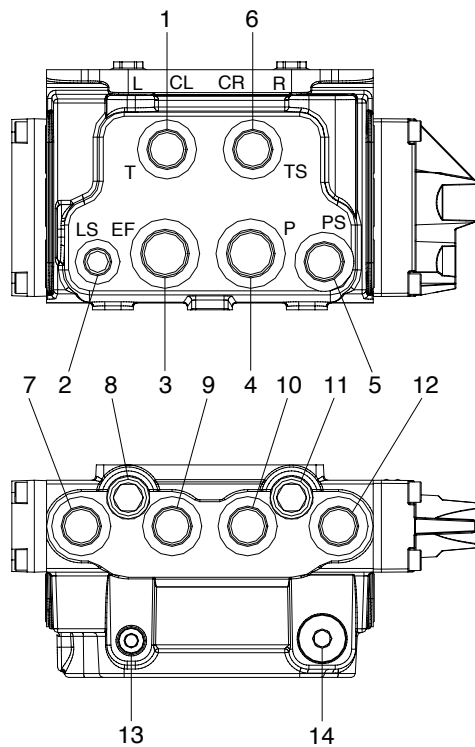

7607SE11

- |                             |                                      |                            |
|-----------------------------|--------------------------------------|----------------------------|
| 1 To tank                   | 7 From steering unit L port          | 13 Relief valve            |
| 2 To emergency system       | 8 Shock & suction valve(Left side)   | 14 Check valve             |
| 3 To main control valve     | 9 To steering cylinder(Left side)    | 15 Main steering spool     |
| 4 From main pump            | 10 To steering cylinder(Right side)  | 16 Pressure reducing valve |
| 5 To steering unit P port   | 11 Shock & suction valve(Right side) | 17 Metering spool          |
| 6 From steering unit T port | 12 From steering unit R port         | 18 Priority spool          |

## 2) OPERATION

### (1) Neutral

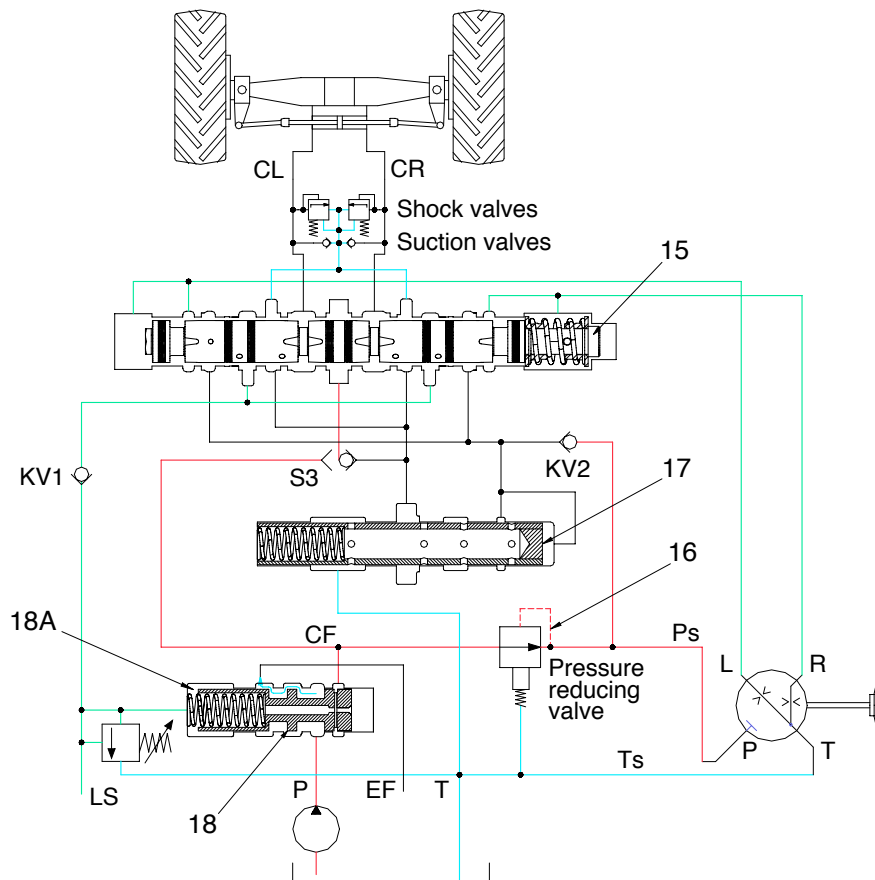

7607SE12

- In neutral position, the oil will pass from the pump across the integrated priority valve(18) in the steering valve for discharge through the EF port. When the steering unit is in neutral, flow through it is blocked and all flow through the priority valve(18) in steering valve is directed out the EF port and passed to the main control valve.
- When the engine is turned off, the priority valve spool(18) is pushed to the right by the spring. The passage to the EF port is blocked while the passage to the CF port is open.
- When the machine is started, EF port of the steering valve may be connected to the working hydraulic. Maximum pressure on the EF port = 210bar.
- The operating pressure in the loader system has not effected on the operation of the priority valve(18) of steering valve. Independently of operation of the loader actuated in relief, the priority valve(18) will not shift until the machine is steered.
- A part of flow through the priority valve spool(18) will flow to P port of steering unit through pressure reducing valve. Also flow as pilot signal of steering through the priority valve spool(18) passes from the P port through the dynamic orifice and into the LS line. It flows to the tank through the LS orifice in main spool.
- In neutral position, the main spool will be in its center position. This means that knocks and impacts from the cylinder are not transmitted to the steering unit. The steering valve is thus of the non-reaction type.



### (3) Turning right

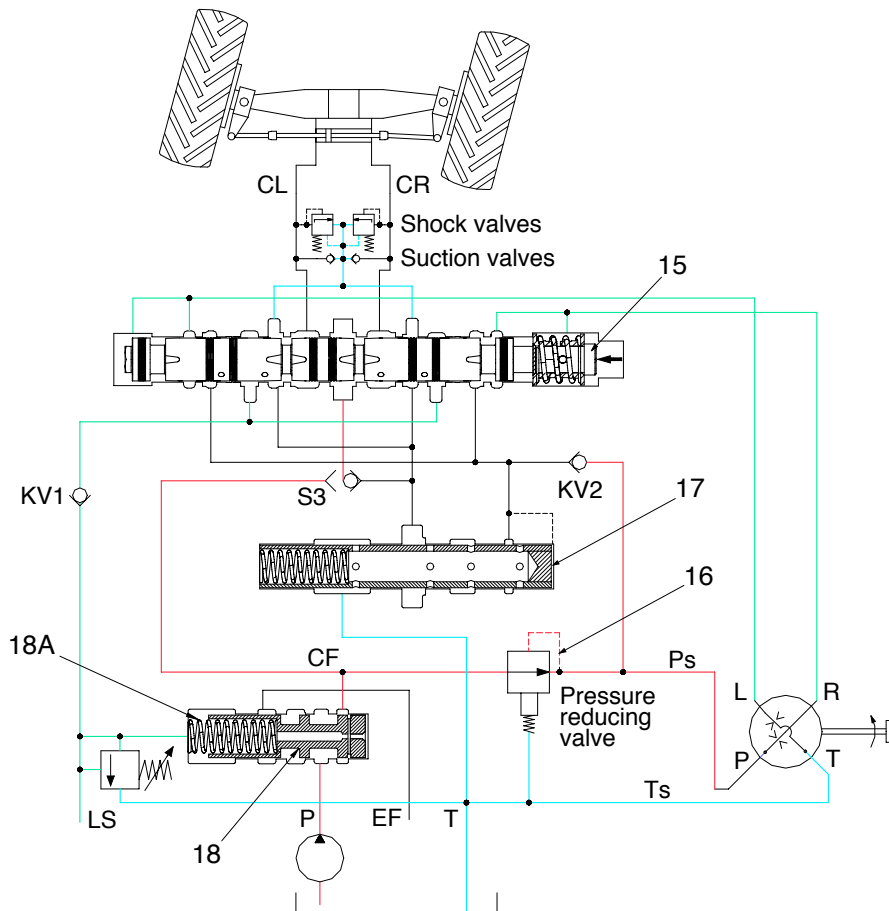

7607SE14

- When the steering wheel is turned to the right, the pressure oil from the steering unit fill on the right side chamber of main steering spool(15), and main steering spool(15) moves to the left in the direction.
- At the same time of moving of main steering spool(15), LS signal will be blocked.
- If LS signal of main steering spool(15) is blocked, it cause to increase pressure of left chamber of priority valve(18A) and then priority valve(18) to be pushed to right side. Consequently, oil will flow via CF of priority valve to main spool. that oil will push steering cylinder rod out and it will cause wheel loader to be steered to right side.
- The rate of movement of main steering spool(15) is concluded as flow rate, which is kept in right chamber from steering unit. Furthermore the rate controls speed of movement for cylinder.
- When the cylinder reaches to end position, pressure of oil flowing through main steering spool(15) will get to be increased. If the oil pressure increase up to relief pressure to be set, relief valve will be activated. It result in decreasing pressure of left chamber of priority valve(18A), and will push priority valve(18) to right side. Then, oil flow to cylinder will be blocked.

#### (4) Pressure reducing valves

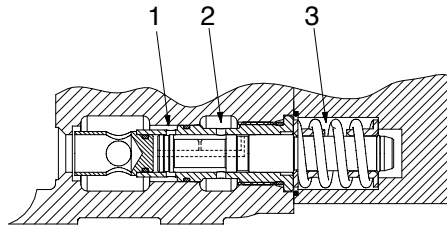

7607SE15

- Pressure reducing valve is a valve, which is supplying pilot oil to steering unit. That is one of advantage of steering system adopting steering valve.
- Pressure reducing valves are pressure-limiting devices that limit pressure in one portion of a circuit while leaving system pressure unaffected. Pressure reducing valves allow flow to pass from(1) to (2) until the pressure at (1) reaches the predetermined setting, at which point the spool shifts to restrict input flow from(1) (reducing mode) or to open flow from (2) to (3) (relieving mode) as needed to maintain the regulated pressure at (2).

#### (5) Relief valve

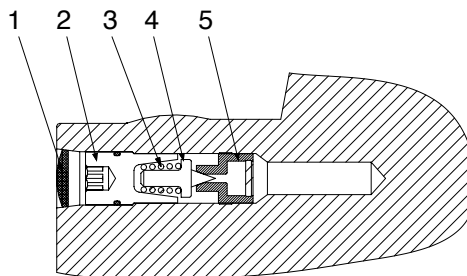

7607SE16

- |   |                  |   |            |
|---|------------------|---|------------|
| 1 | Plastic plug     | 4 | Thrust pad |
| 2 | Adjustment screw | 5 | Valve seat |
| 3 | Spring           |   |            |

#### FUNCTION

The main relief valve is inside the steering valve, and set the maximum circuit pressure of the steering circuit.

When the steering valve is being actuated, if the steering circuit goes up above the set pressure of this valve, oil will be relieved, the priority valve spool will be actuated, and the oil will be flow to EF port.

## 4. STEERING UNIT

### 1) STRUCTURE

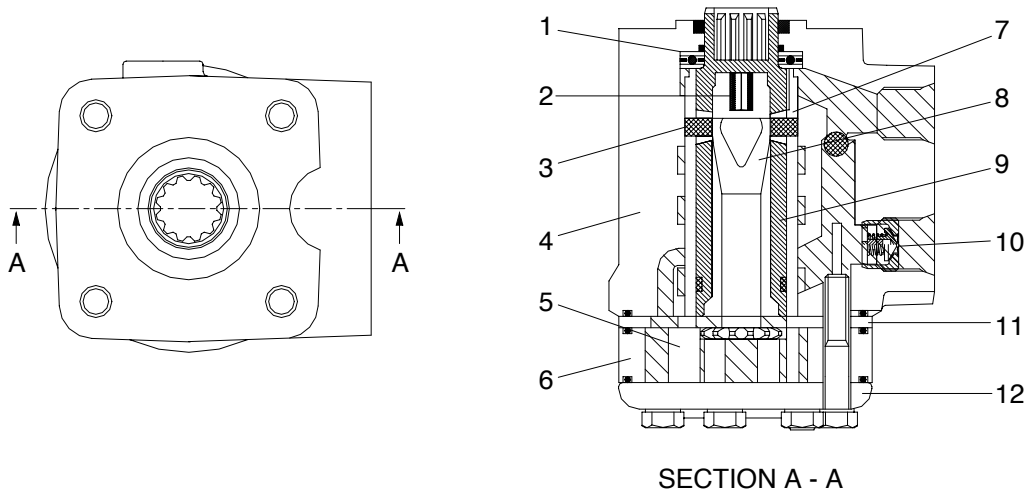

7607SE17

1	Bearing	5	Gear wheel	9	Spool
2	Neutral position spring	6	Gear rim	10	Check valve
3	Cross pin	7	Sleeve	11	Distributor plate
4	Housing	8	Cardan shaft	12	End cover

### 2) OPERATION

The steering unit consists of a rotary valve and a rotary meter.

Via a steering column the steering unit is connected to the steering wheel of the machine.

When the steering wheel is turned, oil is directed from the steering system pump via the rotary valve (spool and sleeve) and rotary meter (gear wheel set) to the cylinder ports L or R, depending on the direction of turn. The rotary meter meters the oil flow to the steering cylinder in proportion to the angular rotation of the steering wheel.

Spool(9) is connected directly to the drive shaft of steering wheel. It is connected to sleeve(7) by cross pin(3) (not in contact with the spool when the steering wheel is at neutral) and neutral position spring(2).

Cardan shaft(8) is meshed at the top with cross pin(3) and forms one unit with sleeve(7).

At the same time, it is meshed with gear rim(5) of the gerotor set by spline.

There are four ports in valve body. They are connected to the pump circuit, tank circuit, and the head, and left and right steering cylinder. In addition, the pump port and tank port are connected inside the body by the check valve. Therefore, if there is any failure in the pump of engine, oil can be sucked in directly from the tank through the check valve.

## 5. CUSHION VALVE

### 1) STRUCTURE

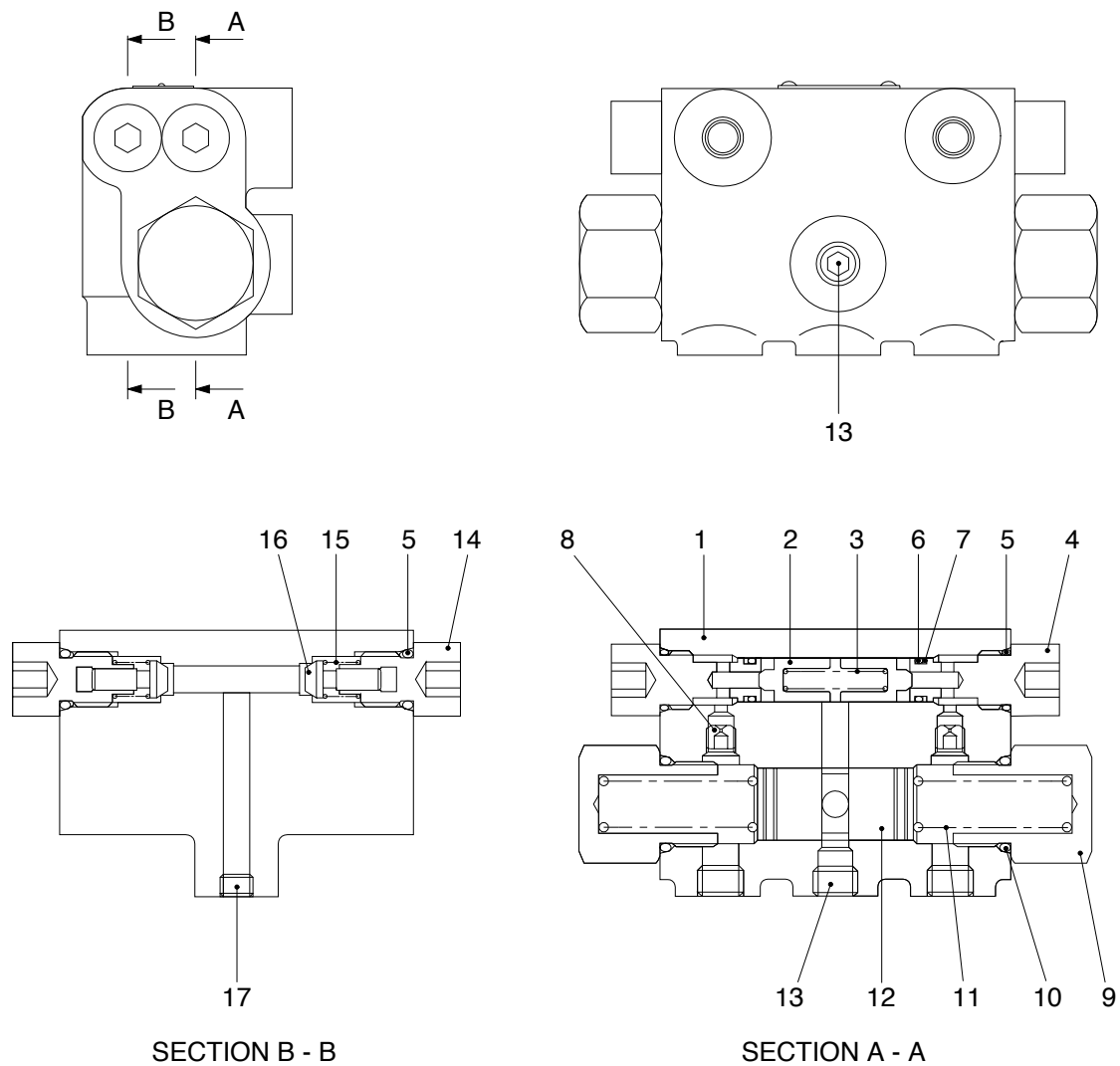

- |   |            |    |           |    |        |
|---|------------|----|-----------|----|--------|
| 1 | Housing    | 7  | Back ring | 13 | Plug   |
| 2 | Poppet     | 8  | Orifice   | 14 | Plug   |
| 3 | Spring     | 9  | Plug      | 15 | Spring |
| 4 | Valve seat | 10 | O-ring    | 16 | Poppet |
| 5 | O-ring     | 11 | Spring    | 17 | Plug   |
| 6 | O-ring     | 12 | Spool     |    |        |

7607SE18

## 2) OPERATION

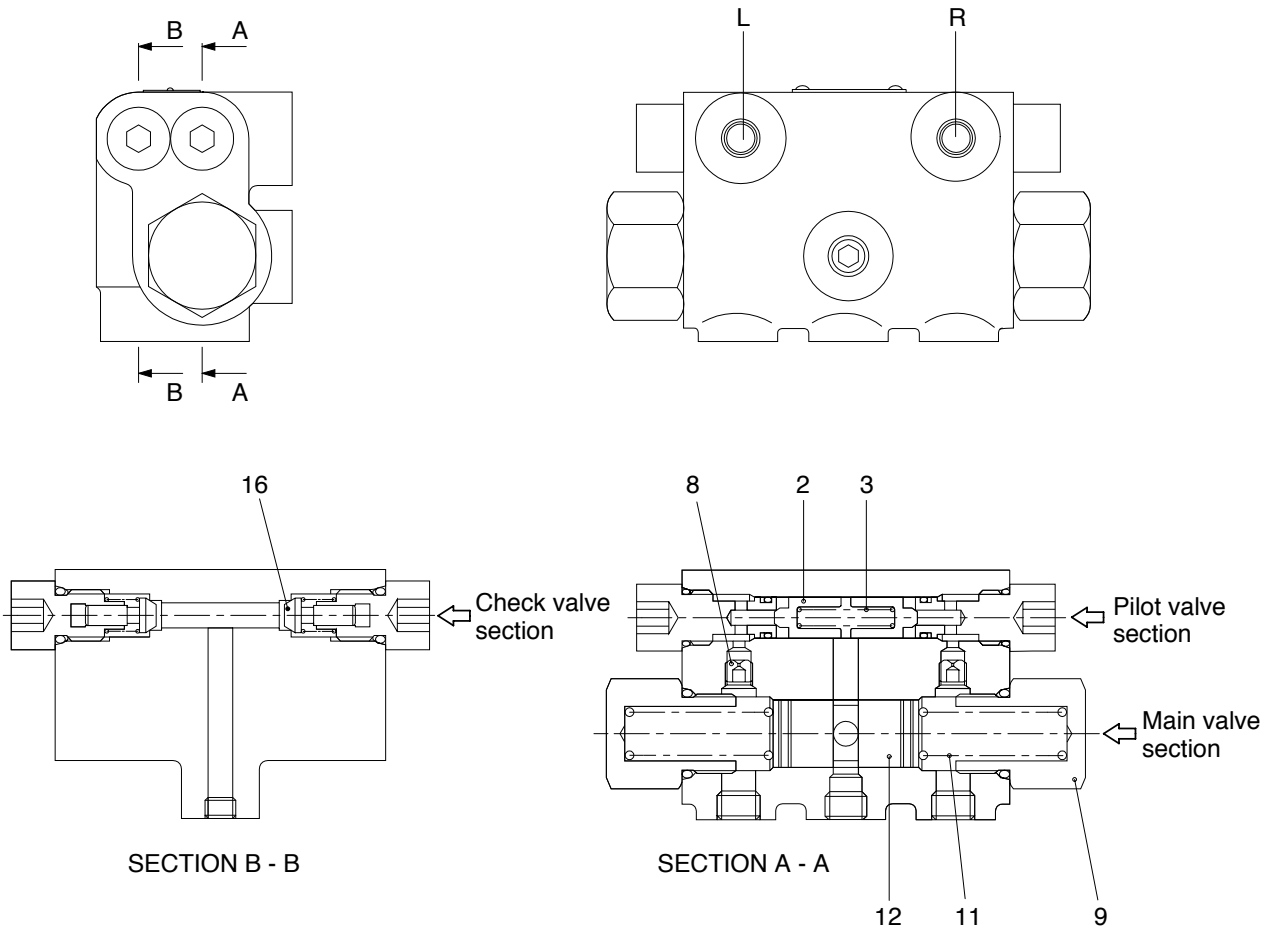

7607SE19

The cushion valve is a valve that eliminates steering jerk motion. It makes a higher pressurized oil to flow into another line in order to prevent the shock on steering system.

The pressure by rapid supplied pressurized oil from R port is higher than the spring(3) force, so it press and open the poppet(2). Then the oil flows to the central groove of the spool(12), and flows to L port through the poppet of the check valve(16) on L port side.

At this time, this pressurized oil flows to the pressure area of the plug(9) through the orifice(8), and this force is higher than the spring(11) force plus the oil pressure on L port side, so the spool(12) is shifted to the right. The flow of the supplied oil to L port side through the poppet(2) from R port side is trapped.

The flow of this instant oil makes the function of the cushion. After this operation, the normal steering operation is not affected because this valve is not operated any longer.

Also, for the response of the pressure when the operation is slow as a cushion effect is not required, the spool(12) is closed before the poppet(2) is opened, so this valve is not operated.

## 6. STEERING CYLINDER

### 1) STRUCTURE

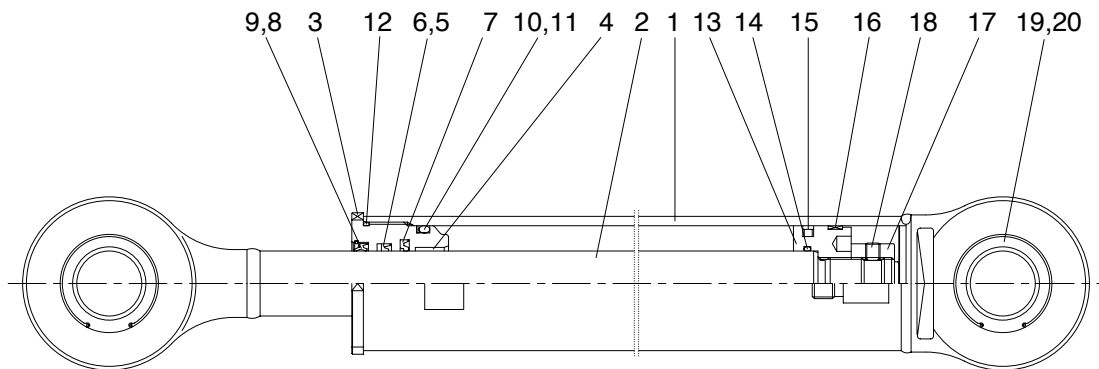

7607SE05

1	Tube assembly	8	Dust wiper	15	Piston seal
2	Rod assembly	9	Snap ring	16	Wear ring
3	Gland	10	O-ring	17	Lock nut
4	Bushing	11	Back up ring	18	Set screw
5	Rod seal	12	O-ring	19	Spherical bearing
6	Back up ring	13	Piston	20	Retaining ring
7	Buffer ring	14	O-ring		

### 2) OPERATION

This machine use to cross connected cylinder for steering operation.

The steering cylinder use a gland(3) to remove piston and sealed seals. Dust wiper(8) located on the in side of the gland protects cylinder inner parts from dust. The piston(13) is fastened to the rod(2) by a nut(17).

The piston uses a single wear ring(16) with a piston seal(15) to seal between the piston and tube. The gland seals against the tube with two O-rings. The rod is sealed against the gland with a rod seal(5).

## **GROUP 2 OPERATIONAL CHECKS AND TROUBLESHOOTING**

### **1. OPERATIONAL CHECKS**

This procedure is designed so the service man can make a quick check of the steering system using a minimum amount of diagnostic equipment. If you need additional information, refer to structure and function in group 1.

A location will be required which is level and has adequate space to complete the checks.



The engine and all other major components must be at operating temperature for some checks.

Locate system check in the left column and read completely, following this sequence from left to right. Read each check completely before performing.

At the end of each check, if no problem is found(OK), that check is complete or an additional check is needed. If problem is indicated(NOT OK), you will be give repair required and group location. If verification is needed, you will be give next best source of information :

- Chapter 2 : Troubleshooting
- Group 3 : Tests and adjustments

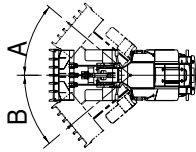
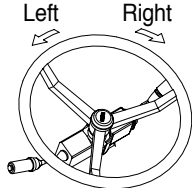
**Hydraulic oil must be at operating temperature for these checks(Refer to page 6-50).**

Item	Description	Service action
<p><b>Steering unit check</b></p>	 <p>Run engine at low idle.</p> <p>Turn steering wheel until frames are at maximum right(A) and then left(B) positions.</p> <p><b>LOOK</b> : Frames must move smoothly in both directions.</p> <p>When steering wheel is stopped, frames must stop.</p> <p><b>FEEL</b> : Excessive effort must not be required to turn steering wheel.</p> <p><b>NOTE</b> : It is normal for steering to drift from stops when steering wheel is released.</p>	<p><b>OK</b> Check completed.</p> <p><b>NOT OK</b> Go to next check.</p>
<p><b>Steering system leakage check</b> Heat hydraulic oil to operating temperature. Run engine at high idle.</p>	 <p>Turn steering wheel rapidly until frames are against stop.</p> <p>Hold approximately 2kg on steering wheel.</p> <p>Count steering wheel revolutions for 1 minute.</p> <p>Repeat test in opposite direction.</p> <p><b>LOOK</b> : Steering wheel should rotate less than 7rpm.</p> <p><b>NOTE</b> : Use good judgment; Excessive steering wheel rpm does not mean steering will be affected.</p>	<p><b>OK</b> Check completed.</p> <p><b>NOT OK</b> Do steering system leakage test in group 3 to isolate the leakage.</p>
<p><b>Priority valve(In steering valve) low pressure check</b></p>	<p>Park machine on a hard surface.</p> <p>Hold brake pedal down.</p> <p>Run engine at high idle.</p> <p>Steer machine to the right and left as far as possible.</p> <p><b>LOOK</b> : Machine must turn at least half way to the right and left stops.</p>	<p><b>OK</b> Check completed.</p> <p><b>NOT OK</b> Do priority valve pressure test in group 3.</p>
<p><b>Priority valve(In steering valve) high pressure check</b> Run engine at high idle.</p>	 <p>Steer to steering stop and release steering wheel.</p> <p>Roll bucket back and hold over relief and observe engine rpm.</p> <p>Turn steering wheel to steering stop and hold, observe engine rpm.</p> <p><b>LOOK</b> : Steering stall engine rpm must be higher than hydraulic stall rpm.</p>	<p><b>OK</b> Check completed.</p> <p><b>NOT OK</b> Priority pressure is set too high. Do priority valve pressure test in group 3.</p>

## 2. TROUBLESHOOTING

Diagnose malfunction charts are arranged from most probable and simplest to verify, to least likely, more difficult to verify. Remember the following steps when troubleshooting a problem :

Step 1. Operational check out procedure(See group 3 in section 1)

Step 2. Operational checks(In this group)

Step 3. Troubleshooting

Step 4. Tests and adjustments(See group 3)

Problem	Cause	Remedy
<b>No steering</b>	Low oil level Failed steering pump Failed main pump drive Stuck priority valve spool Broken priority valve spring Relief valve in steering valve stuck open.	Add recommended oil. Remove and inspect return filter for metal pump particles. Do main pump flow test. Remove and inspect priority valve spool. Remove and inspect spring. Do relief cartridge leakage test in group 3.
<b>No hydraulic functions steering normal</b>	Faulty or misadjusted pilot supply unit valve Stuck open system relief valve Locked safety valve Plugged pilot line filter Failed hydraulic pump Low secondary pressure of RCV	Do pilot supply unit test in group 3. Replace relief valve. Unlock safety valve. Inspect and replace. Remove and inspect the pump. Check the pressure and replace if necessary.

Problem	Cause	Remedy
<b>Slow or hard steering</b>	<p>Too much friction in the mechanical parts of the machine</p> <p>Cold oil</p> <p>Low priority valve pressure setting</p> <p>Worn hydraulic pump</p> <p>Sticking priority valve spool</p> <p>Broken priority valve spring</p>	<p>Lubricate bearings and joints of steering column or repair if necessary. Check steering column installation.</p> <p>Warm the hydraulic oil.</p> <p>Do priority valve pressure test in group 3. Clean or replace cartridge in steering valve.</p> <p>Do hydraulic pump performance check .</p> <p>Remove and inspect.</p> <p>Remove and inspect.</p>
<b>Constant steering to maintain straight travel</b>	<p>Air in system</p> <p>Leakage in steering system</p> <p>Worn steering unit</p> <p>Leaf spring without spring force or broken</p> <p>Spring in double shock valve broken</p> <p>Gear wheel set worn</p> <p>Cylinder seized or piston seals worn</p>	<p>Check for foamy oil.</p> <p>Do steering system leakage check.</p> <p>Do steering system leakage check. Do steering unit neutral leakage test in group 3.</p> <p>Replace leaf springs.</p> <p>Replace shock valve.</p> <p>Replace gear wheel set.</p> <p>Replace defects parts.</p>
<b>Slow steering wheel movement will not cause any frame movement</b>	<p>Leakage in steering unit gerotor</p> <p>Worn steering unit gerotor</p>	<p>Do steering system leakage check.</p> <p>Do steering leakage check.</p>
<b>Steering wheel can be turned with frames against steering stop</b>	<p>Leakage in steering system</p>	<p>Do steering system leakage check.</p>
<b>Steering wheel turns with no resistance and causes no frame movement</b>	<p>Broken steering column or splined coupling</p> <p>Lack of oil in steering unit</p> <p>Leakage in steering system</p>	<p>Remove and inspect.</p> <p>Start engine and check steering operation.</p> <p>Do steering system leakage test in group 3.</p>

Problem	Cause	Remedy
<b>Erratic steering</b>	Air in oil Low oil level Sticking priority valve spool Loose cylinder piston Damaged steering unit	Check for foamy oil. Add recommended oil. Remove and inspect spool. Remove rod to inspect piston. Remove and inspect.
<b>Spongy or soft steering</b>	Air in oil Low oil level	Check for foamy oil. Add recommended oil.
<b>Free play at steering wheel</b>	Loose steering wheel nut Worn or damaged splines on steering column or unit	Tighten. Inspect.
<b>Steering unit binding or steering wheel does not immediately return to neutral when released</b>	Binding in steering column or misalignment of column High return pressure Contamination in steering unit Large particles of contamination in steering unit	Inspect. Check for a pinched or damaged return line. Inspect hydraulic filter for contamination. Repair cause of contamination. Flush hydraulic system. Inspect hydraulic filter for contamination. Repair cause of contamination. Flush hydraulic system.
<b>Steering unit locks up</b>	Worn or damaged steering unit	Repair or replace steering unit.
<b>Abrupt steering wheel oscillation</b>	Improperly timed gerotor gear in steering unit	Time gerotor gear.
<b>Steering wheel turns by itself</b>	Lines connected to wrong port	Reconnect lines.
<b>Vibration in steering system or hoses jump</b>	High priority valve setting	Do priority valve pressure test in group 3.
<b>Neutral position of steering wheel cannot be obtained, i.e. there is a tendency towards "motoring"</b>	Steering column and steering unit out of line Too little or no play between steering column and steering unit input shaft Pinching between inner and outer spools	Align the steering column with steering unit. Adjust the play and, if necessary, shorten the splines journal. Contact the nearest service shop.

Problem	Cause	Remedy
<p><b>"Motoring" effect.</b>  <b>The steering wheel can turn on its own.</b></p>	<p>Leaf springs are stuck or broken and have therefore reduced spring force</p> <p>Inner and outer spools pinch, possibly due to dirt</p> <p>Return pressure in connection with the reaction between differential cylinder and steering unit too high</p> <p>Oil is needed in the tank</p> <p>Steering cylinder worn</p> <p>Gear wheel set worn</p> <p>Spacer across cardan shaft forgotten</p>	<p>Replace leaf springs.</p> <p>Clean steering unit or contact the nearest service shop.</p> <p>Reduce return pressure.</p> <p>Fill with clean oil and bleed the system.</p> <p>Replace or repair cylinder.</p> <p>Replace gear wheel set.</p> <p>Install spacer.</p>

Problem	Cause	Remedy
<b>Backlash</b>	Cardan shaft fork worn or broken Leaf springs without spring force or broken Worn splines on the steering column	Replace cardan shaft. Replace leaf springs. Replace steering column.
<b>"Shimmy" effect. The steered wheels vibrate. (Rough tread on tires gives vibrations)</b>	Air in the steering cylinder Mechanical connections or wheel bearings worn High priority valve setting pressure	Bleed cylinder. Find and remove the reason for air collection. Replace worn parts. Set pressure as regular value.
<b>Steering wheel can be turned slowly in one or both directions without the steered wheels turning.</b>	One or both shock valves are leaky or are missing in steering valve	Clean or replace defective or missing valves.
<b>Steering is too slow and heavy when trying to turn quickly.</b>	Insufficient oil supply to steering unit, pump defective or number of revolutions too low Relief valve setting too low Relief valve sticking owing to dirt Spool in priority valve sticking owing to dirt. Too weak spring in priority valve	Replace pump or increase number of revolutions. Adjust valve to correct setting. Clean the valve. Clean the valve, check that spool moves easily without spring. Replace spring by a stronger.
<b>"Kick back" in steering wheel from system. Kicks from wheels.</b>	Fault in the system	Contact authorized man or shop.

Problem	Cause	Remedy
<b>Heavy kick-back in steering wheel in both directions.</b>	Wrong setting of cardan shaft and gear-wheel set	Correct setting as shown in service manual.
<b>Turning the steering wheel activates the steered wheels opposite.</b>	Hydraulic hoses for the steering cylinders have been switched around	Connect lines to correct ports.
<b>Hard point when starting to turn the steering wheel</b>	Spring force in priority valve too weak Clogged orifices in LS side in priority valve Oil is too thick(Cold)	Replace spring by a stronger. Clean orifices in spool and in connecting plugs for LS. Let motor run until oil is warm.
<b>Too little steering force (Possibly to one side only).</b>	Pump pressure too low Too little steering cylinder Piston rod area of the differential cylinder too large compared with piston diameter	Correct pump pressure. Fit a larger cylinder. Fit cylinder with thinner piston rod or 2 differential cylinders.
<b>Leakage at either input shaft, end cover, gear-wheel set, housing or top part.</b>	Shaft defective Screws loose Washers or O-rings defective	Replace shaft seal. Tighten screws. Replace.

## GROUP 3 TESTS AND ADJUSTMENTS

### 1. HYDRAULIC OIL CLEAN UP PROCEDURE USING PORTABLE FILTER CADDY

#### Service equipment and tool.

- Portable filter caddy
- Two 3658mm(12ft) × 1" I.D. 100R1 hoses with 3/4 M NPT ends
- Quick disconnect fittings
- Discharge wand
- Various size fittings and hoses

**Brake system uses oil from hydraulic oil tank. Flush all lines in the steering system.**

**Disassemble and clean major components for steering system.**

**Steering components may fail if steering system is not cleaned after hydraulic oil tank contamination.**

- 1) If hydraulic system is contaminated due to a major component failure, remove and disassemble steering cylinders to clean debris from cylinders.
- 2) Install a new return filter element. Clean filter housing before installing new element.

**For a failure that creates a lot of debris, remove access cover from hydraulic oil tank. Drain and clean hydraulic oil tank of fill the specified oil to hydraulic oil tank through upper cover.**

- 3) To minimize oil loss, pull a vacuum in hydraulic oil tank using a vacuum pump. Connect filter caddy suction line to drain port at bottom of hydraulic oil tank using connector. Check to be sure debris has not closed drain port.
- 4) Put filter caddy discharge line into hydraulic oil tank filter hole so end is as far away from drain port as possible to obtain a through cleaning of oil.

5) Start the filter caddy. Check to be sure oil is flowing through the filters.

Operate filter caddy approximately 10 minutes so oil in hydraulic oil tank is circulated through filter a minimum of four times.

**Hydraulic oil tank capacity 155 (30.4U.S. gal).**

Leave filter caddy operating for the next steps.

6) Start the engine and run it at high idle.

**For the most effective results, cleaning procedure must start with the smallest capacity circuit then proceed to the next largest capacity circuit.**

7) Operate all functions, one at a time, through a complete cycle in the following order: clam, steering, bucket, and boom. Also include all auxiliary hydraulic functions.

Repeat procedure until the total system capacity has circulated through filter caddy seven times, approximately 30 minutes.

Each function must go through a minimum of three complete cycles for a through cleaning for oil.

**Filtering time for machines with auxiliary hydraulic functions must be increased because system capacity is larger.**

8) Stop the engine. Remove the filter caddy.

9) Install a new return filter element.

10) Check oil level in hydraulic oil tank ; Add oil if necessary.

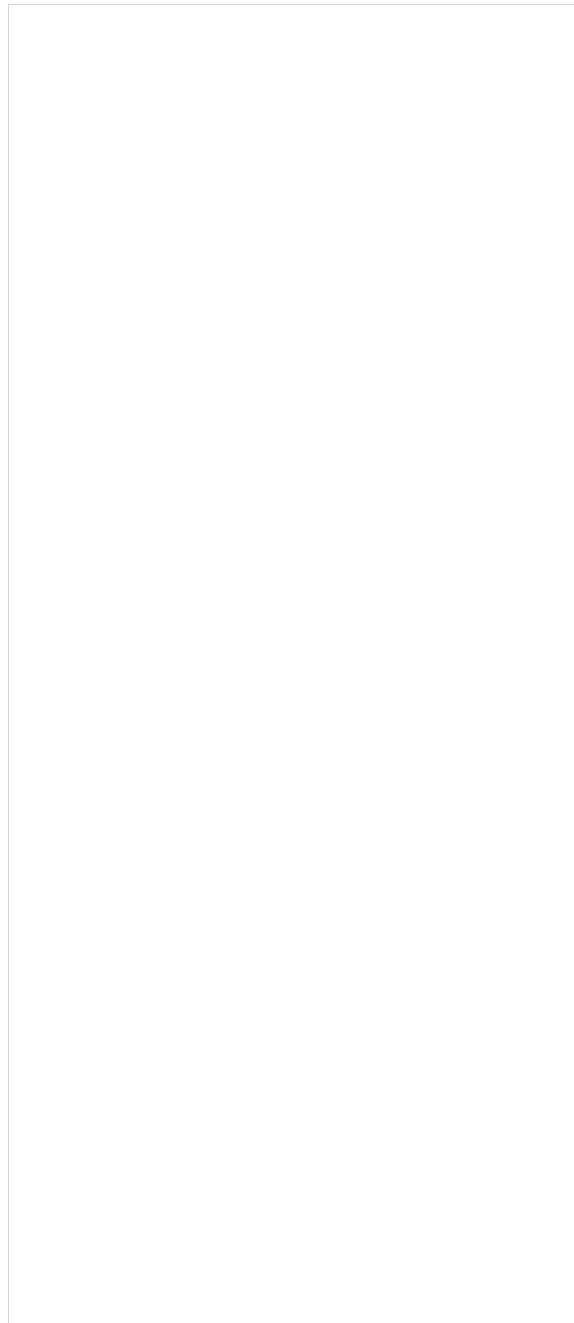

## 2. TEST TOOLS

### 1) CLAMP-ON ELECTRONIC TACHOMETER INSTALLATION

- Service equipment and tools  
Tachometer

A : Clamp on tachometer.

Remove paint using emery cloth and connect to a straight section of injection line within 100mm(4in) of pump. Finger tighten only-do not over tighten.

B : Black clip(-). Connect to main frame.

C : Red clip(+). Connect to transducer.

D : Tachometer readout. Install cable.

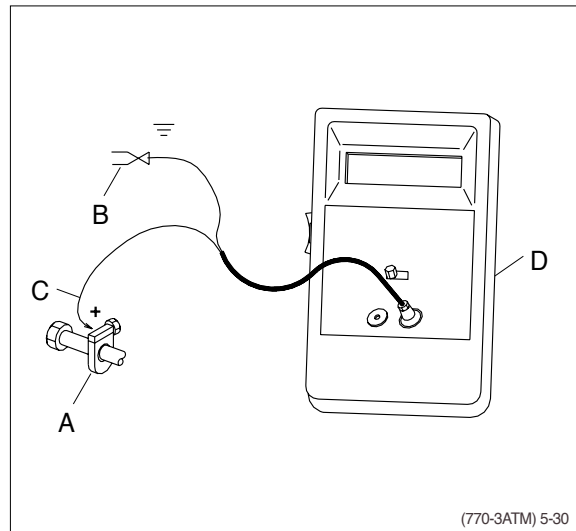

### 2) DIGITAL THERMOMETER INSTALLATION

- Service equipment and tools  
Digital thermometer

A : Temperature probe.

Fasten to a bare metal line using a tie band. Wrap with shop towel.

B : Cable.

C : Digital thermometer.

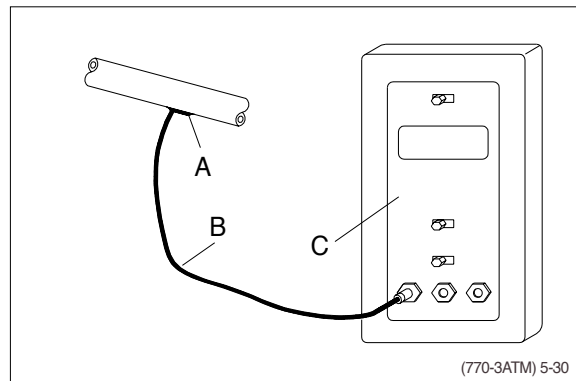

### 3) DISPLAY MONITOR TACHOMETER

The display monitor tachometer is accurate enough for test work.

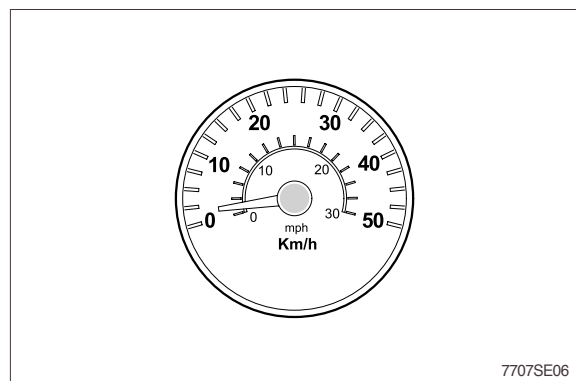

### 3. STEERING SYSTEM RESTRICTION TEST

#### • SPECIFICATION

Oil temperature  $45 \pm 5^{\circ}\text{C}$  ( $113 \pm 9^{\circ}\text{F}$ )  
Engine speed High idle  
Maximum pressure 2.1MPa(21bar,300psi)  
at flow amplifier

#### • GAUGE AND TOOL

Gauge 0~7MPa(0~70bar, 0~1000psi) 2EA

- This test will check for restrictions in the steering system which can cause overheating of hydraulic oil.

- 1) Install temperature reader.  
(See temperature reader installation procedure in this group).
  - 2) Heat hydraulic oil to specifications.  
(See hydraulic oil warm up procedure at page 6-50).
  - 3) Connect fitting and install gauge.
- ▲ Do not operate steering or loader functions or test gauge may be damaged.**
- 4) Run engine at specification and read pressure gauges.

If pressure is more than specification at the steering valve, inspect steering valve for a priority valve spool. Make sure orifice plugs installed in ends of priority valve spool. Check for plugged orifice in steering valve LS port.

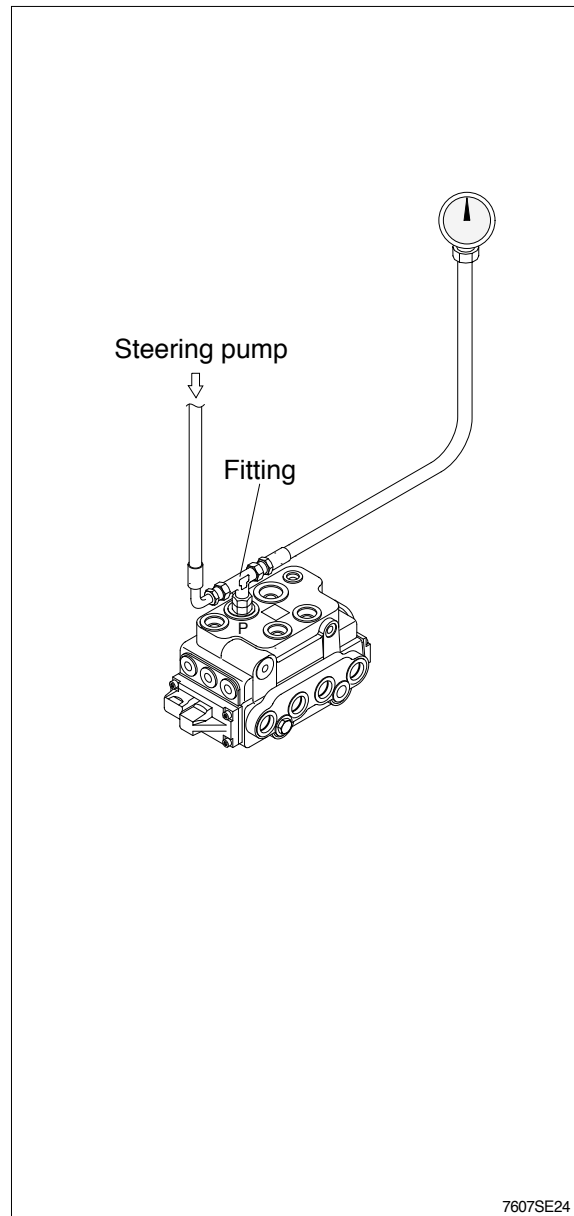

#### 4. STEERING UNIT LEAKAGE TEST

- **SPECIFICATION**

Oil temperature  $45 \pm 5^{\circ}\text{C}$  ( $113 \pm 9^{\circ}\text{F}$ )

Engine speed High idle

Maximum leakage  $7.5 \text{ /min}$  (2gpm)

- **GAUGE AND TOOL**

Temperature reader

Measuring container (Approx. 20 )

Stop watch

- 1) Install frame locking bar to prevent machine from turning.
- 2) Install temperature reader.  
(See temperature reader installation procedure in this group).
- 3) Heat hydraulic oil to specifications.  
(See hydraulic oil warm up procedure at page 6-50).
- 4) Disconnect return hose from fitting.  
Install cap fitting.
- 5) Run engine at specifications. Rotate steering wheel against locking bar using approximately  $1.2\text{kgf} \cdot \text{m}$  of force. Measure oil flow from return hose for 1 minute.
- 6) Leakage is greater than specifications, repair or replace steering unit.

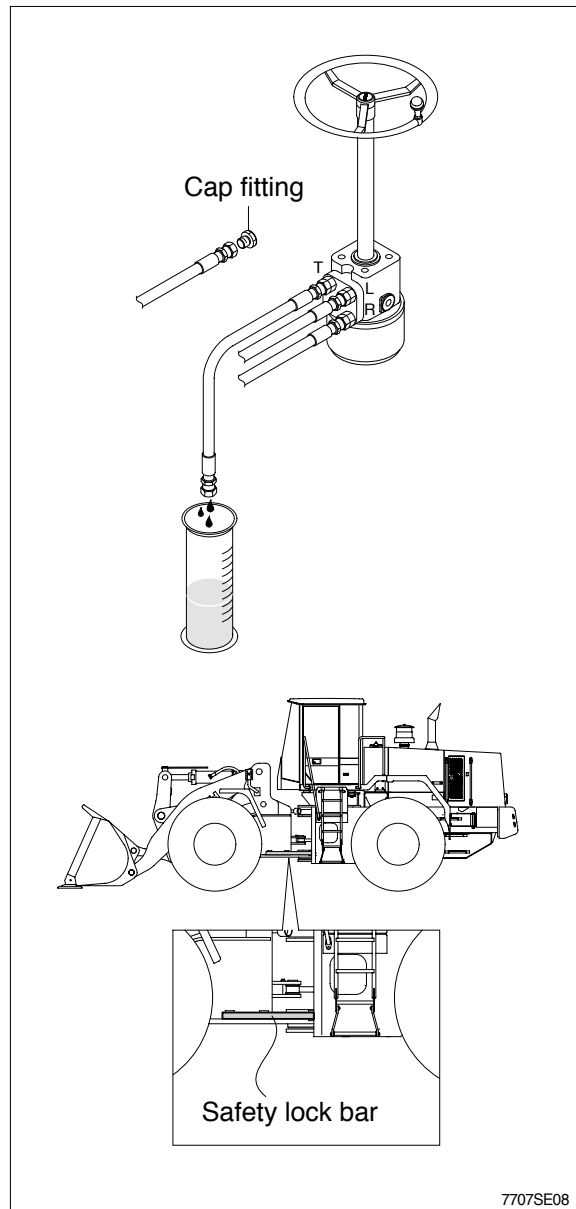

7707SE08

## 5. STEERING VALVE(EHPS) PRESSURE TEST

### • SPECIFICATION

Oil temperature	45 ± 5.C(113 ± 9.F)
Engine speed	High idle
Oil pressure	20.1~21.1MPa (205~215bar, 2900~3100psi)

### • GAUGE AND TOOL

Gauge	0~35MPa(0~350bar, 0~5000psi)
Temperature reader	

- 1) Connect gauge to test port.
- 2) Install temperature reader(See installation procedure in this group).
- 3) Install frame locking bar.
- 4) Heat hydraulic oil to specifications(See hydraulic oil warm up procedure at page 6-50).

- 5) Run engine at specifications and turn steering wheel rapidly hold approximately 22N(5lb force) pressure on wheel with frames locked.

**If steering wheel is turned slowly, it will continue to with the frames locked.**

**This will give an incorrect pressure reading.**

**If steering wheel continues to turn rapidly with the frames locked, steering system leakage is indicated.**

- 6) Read pressure gauge. This is the steering valve relief pressure.
- 7) If pressure is not to specification, turn adjusting screw in relief cartridge using a hex head wrench to adjust pressure.

If pressure cannot be adjusted to specification, disassemble and inspect steering valve.

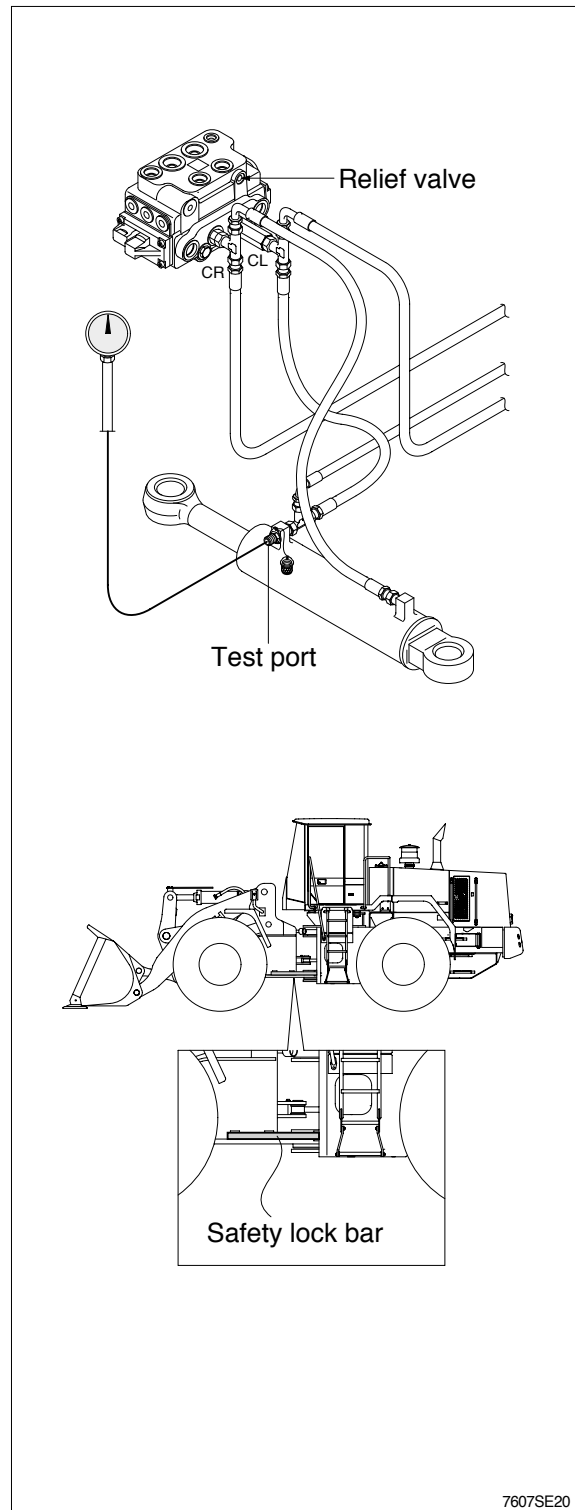

## 6. STEERING VALVE(EHPS) RELIEF CARTRIDGE LEAKAGE TEST

### - SPECIFICATION

Oil temperature  $45 \pm 5^{\circ}\text{C}(113 \pm 9^{\circ}\text{F})$   
Engine speed High idle  
Maximum leakage  $1\text{m}^3/\text{min}(16\text{ drops per min})$

### - GAUGE AND TOOL

Temperature reader  
Measuring container  
Stop watch

- 1) Install temperature reader.  
(See temperature reader installation procedure in this group).
- 2) Heat hydraulic oil to specifications.  
(See hydraulic oil warm up procedure at page 6-50).
- 3) Install plug(A) in Ts port.  
Disconnect line from T port on steering valve. Install plug in line.
- 4) Connect line(B) to steering valve.
- 5) Start engine and run at specification.
- 6) Measure oil leakage from T port.
- 7) If leakage is more than specification, disassemble and inspect relief cartridge for damage or debris.

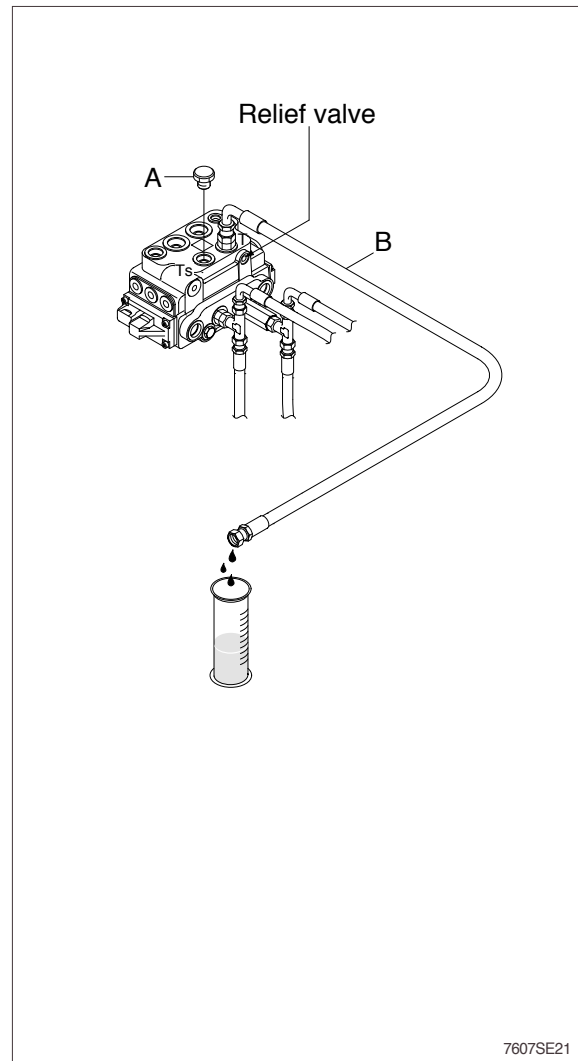

## GROUP 4 DISASSEMBLY AND ASSEMBLY

### 1. STEERING UNIT

#### 1) STRUCTURE

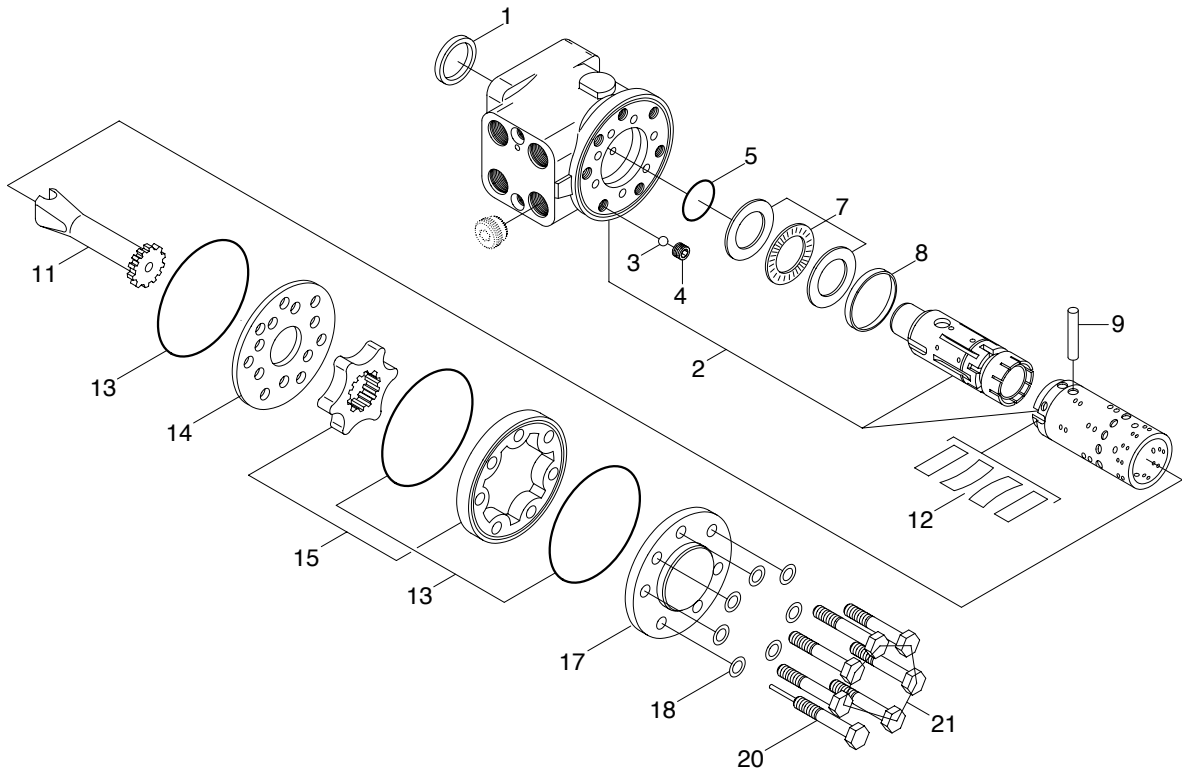

7607SE10

- |   |                        |    |                   |    |                |
|---|------------------------|----|-------------------|----|----------------|
| 1 | Dust seal              | 8  | Ring              | 15 | Gearwheel set  |
| 2 | Housing, spool, sleeve | 9  | Cross pin         | 17 | End cover      |
| 3 | Ball                   | 11 | Cardan shaft      | 18 | Washer         |
| 4 | Thread bushing         | 12 | Set of springs    | 20 | Screw with pin |
| 5 | O-ring                 | 13 | O-ring            | 21 | Screw          |
| 7 | Bearing assembly       | 14 | Distributor plate |    |                |

## 2) TOOLS

(1) Holding tool + Guide ring

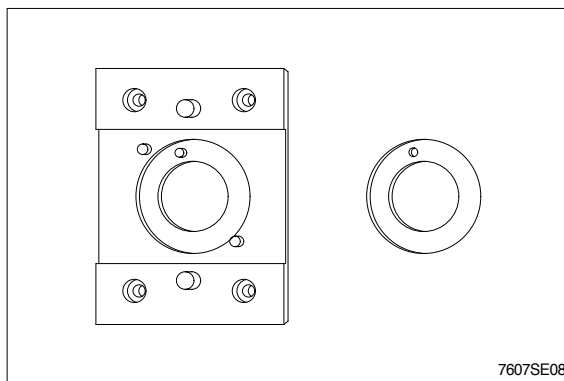

(2) Assembly tool for O-ring and kin-ring.

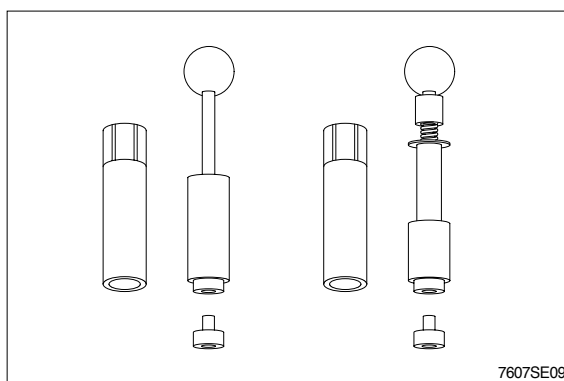

(3) Assembly tool for lip seal.

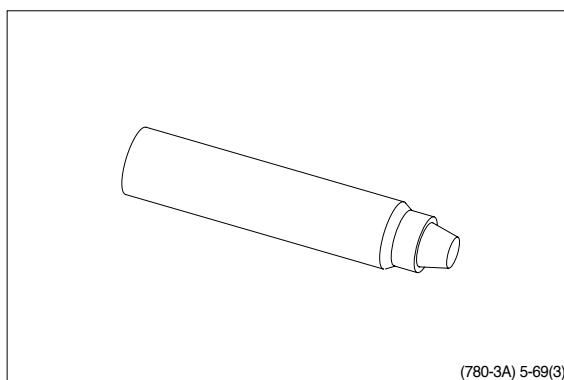

(4) Assembly tool for cardan shaft.

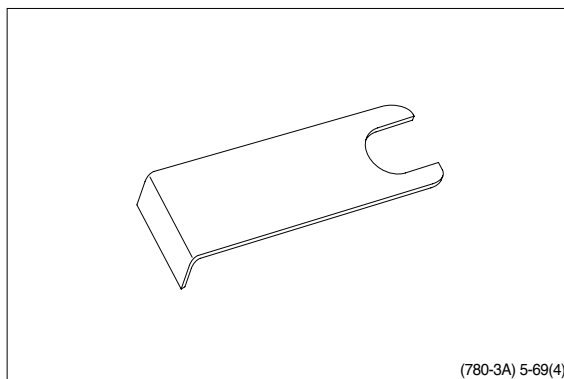

(5) Assembly tool for dust seal.

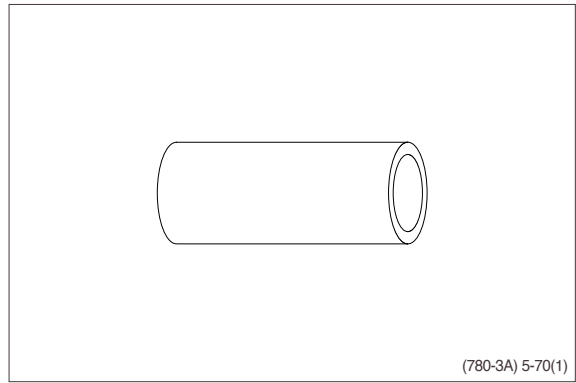

(6) Torque wrench 0~7.1kgf · m  
(0~54.4lbf · ft)  
13mm socket spanner  
6, 8mm and 12mm hexagon sockets  
12mm screwdriver  
2mm screwdriver  
13mm ring spanner  
6, 8 and 12mm hexagon socket spanners  
Plastic hammer  
Tweezers

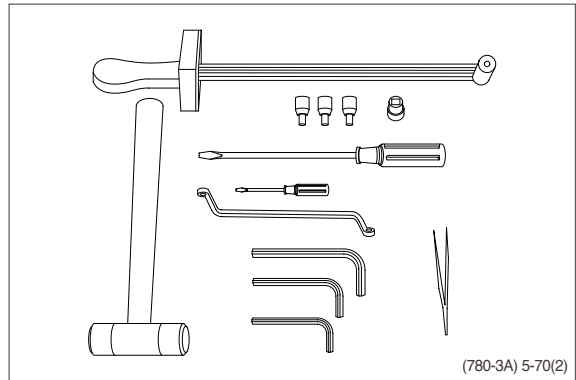

### 3) TIGHTENING TORQUE AND HYDRAULIC CONNECTIONS

#### (1) Hydraulic connections

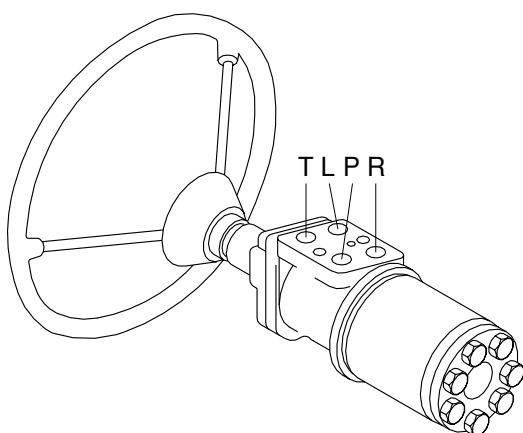

L : Left port  
 R : Right port  
 T : Tank  
 P : Pump

(780-3A) 5-71

#### (2) Tightening torque

Screwed connection	Max. tightening torque [ kgf · m(lbf · ft) ]			
	With cutting edge	With copper washer	With aluminum washer	With O - ring
1/4 BSP.F	4.1(29.7)	2.0(14.5)	3.1(22.4)	-
3/8 BSP.F	6.1(44.1)	2.0(14.5)	5.1(36.9)	-
1/2 BSP.F	10.2(73.8)	3.1(22.4)	8.2(59.3)	-
7/16-20 UNF	-	2.0(14.5)	-	-
3/4-16 UNF	-	6.1(44.1)	-	-
M 12 × 1.5	4.1(29.7)	2.0(14.5)	3.1(22.4)	2.0(14.5)
M 18 × 1.5	7.1(51.4)	2.0(14.5)	5.1(36.9)	5.1(36.9)
M 22 × 1.5	10.2(73.8)	3.1(22.4)	8.2(59.3)	7.1(51.4)

#### 4) DISASSEMBLY

- (1) Disassemble steering column from steering unit and place the steering unit in the holding tool.  
Screw out the screws in the end cover(6-off plus one special screw).

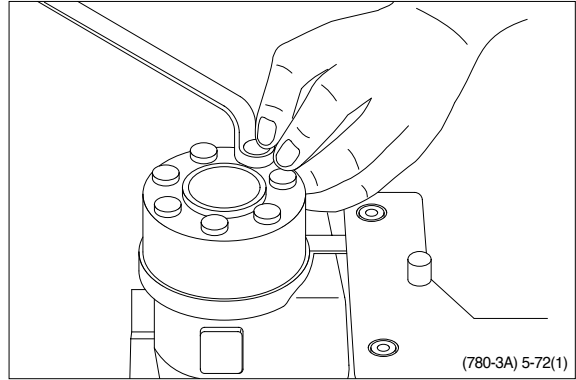

- (2) Remove the end cover, sideways.

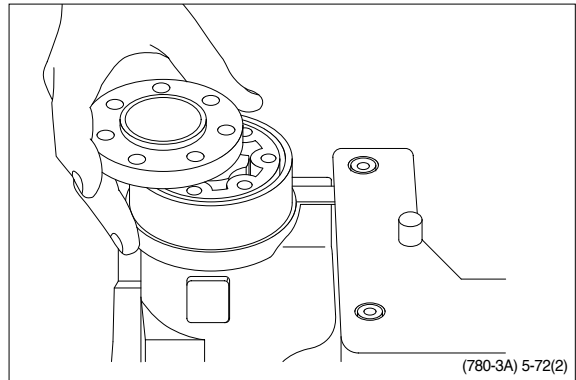

- (3) Lift the gearwheel set (With spacer if fitted) off the unit.  
Take out the two O-rings.

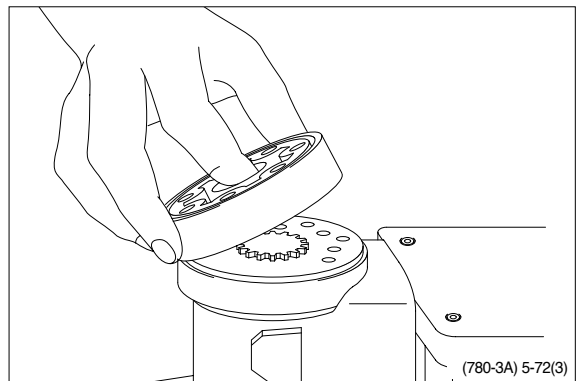

- (4) Remove cardan shaft.

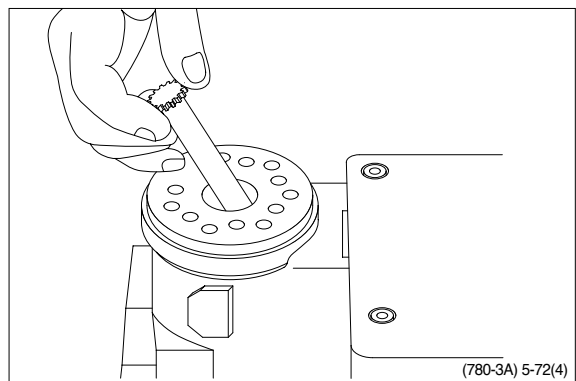

(5) Remove distributor plate.

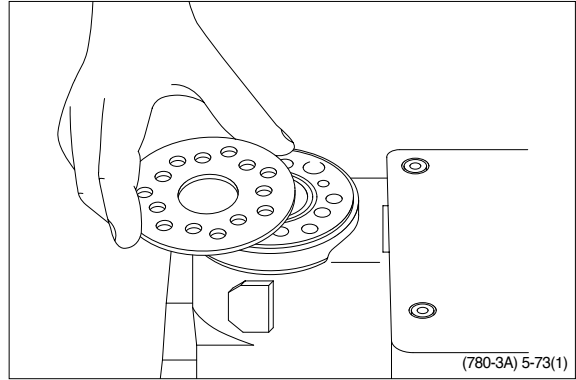

(6) Screw out the threaded bush over the check valve.

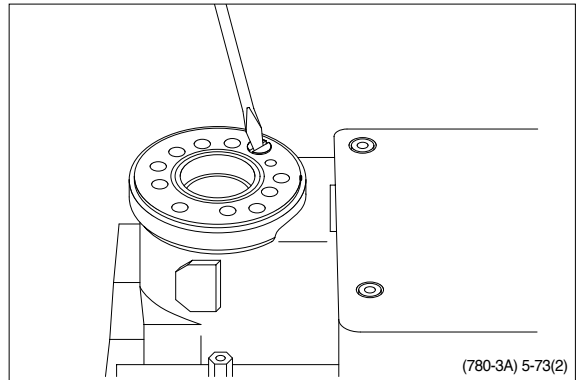

(7) Remove O-ring.

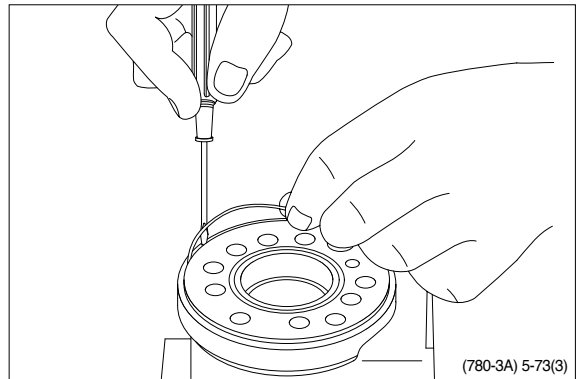

(8) Take care to keep the cross pin in the sleeve and spool horizontal. The pin can be seen through the open end of the spool. Press the spool inwards and the sleeve, ring, bearing races and needle bearing will be pushed out of the housing together.

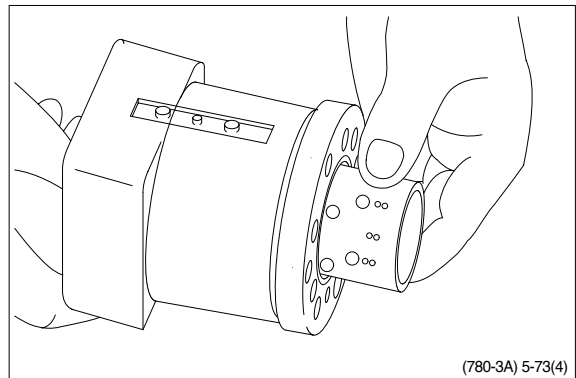

- (9) Take ring, bearing races and needle bearing from sleeve and spool. The outer (Thin) bearing race can sometimes "stick" in the housing, therefore check that it has come out.

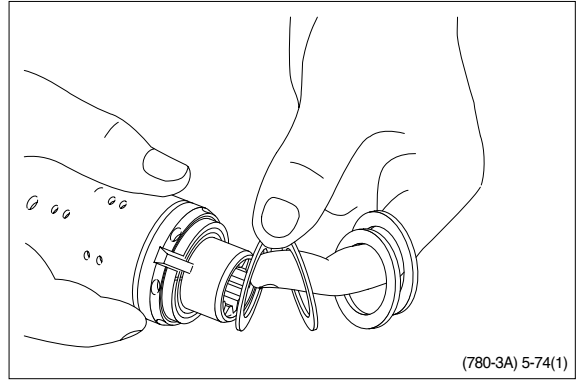

- (10) Press out the cross pin. Use the special screw from the end cover.

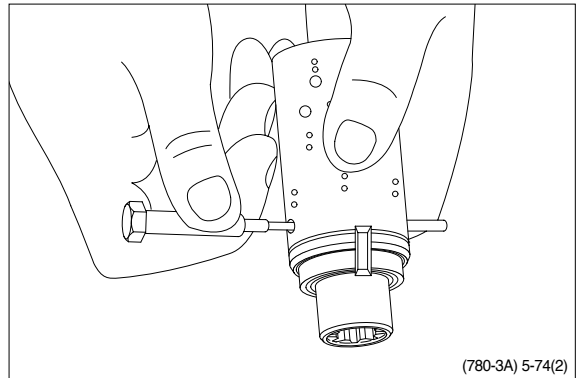

A small mark has been made with a pumice stone on both spool and sleeve close to one of the slots for the neutral position springs (See drawing).

If the mark is not visible, remember to leave a mark of your own on sleeve and spool before the neutral position springs are disassembled.

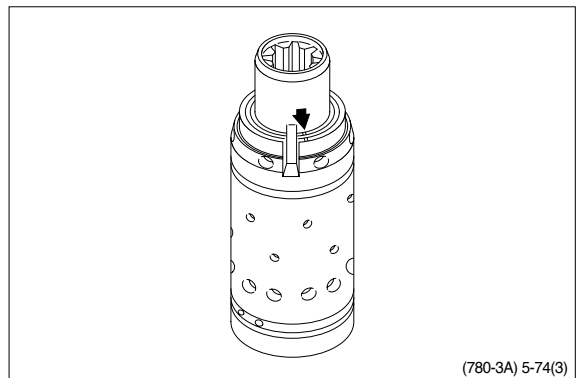

- (11) Carefully press the spool out of the sleeve.

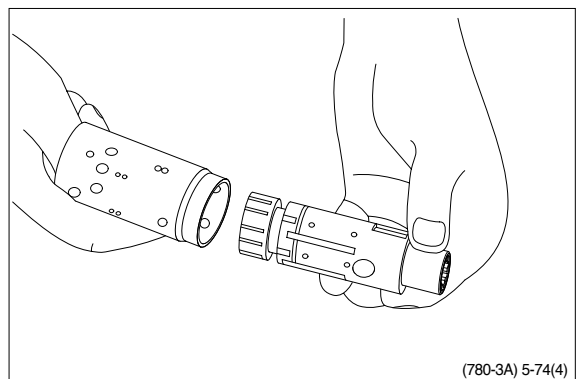

(12) Press the neutral position springs out of their slots in the spool.

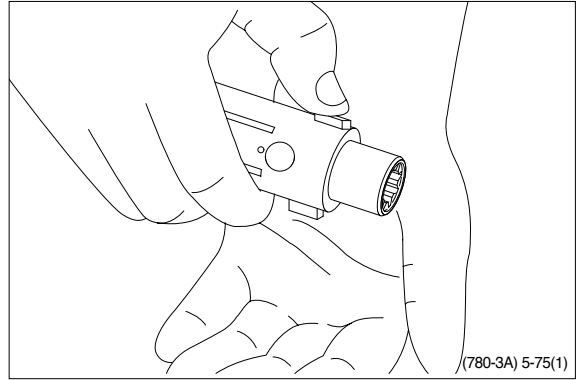

(13) Remove dust seal and O-ring.

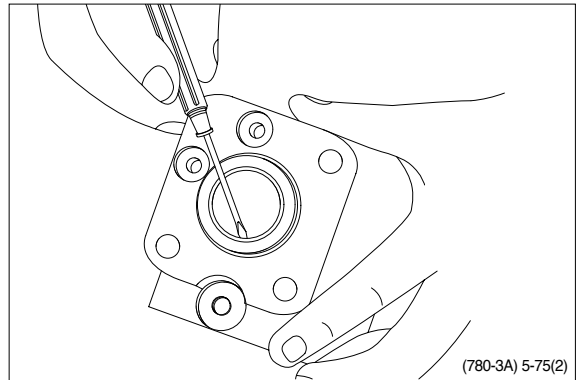

(14) The steering unit is now completely disassembled.

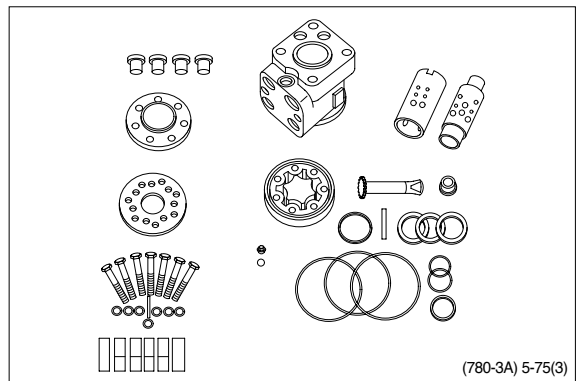

### Cleaning

Clean all parts carefully in Shellsol K or the like.

### Inspection and replacement

Replace all seals and washers. Check all parts carefully and make any replacements necessary.

### Lubrication

Before assembly, lubricate all parts with hydraulic oil.

- (1) Place the two flat neutral position springs in the slot.  
Place the curved springs between the flat ones and press them into place.

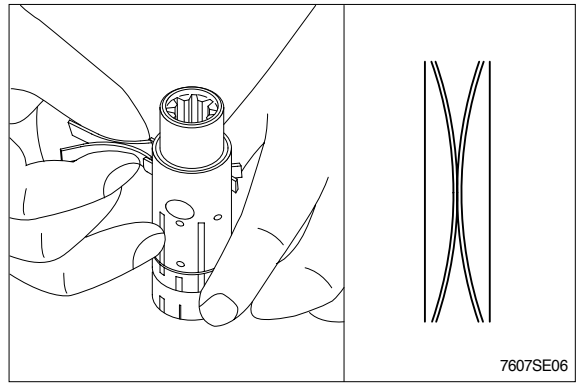

- (2) Line up the spring set.

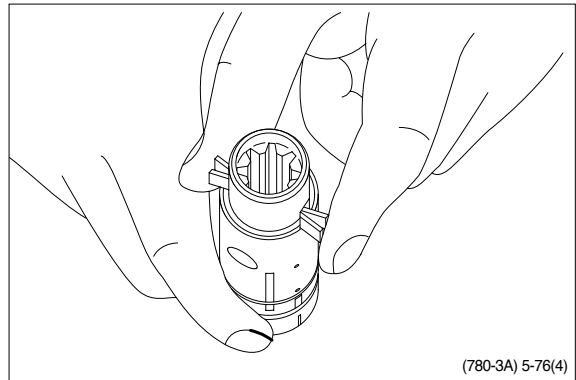

- (3) Assemble the spool/sleeve and make sure the marks on spool and sleeve are opposite each other(see drawing page 5-36).

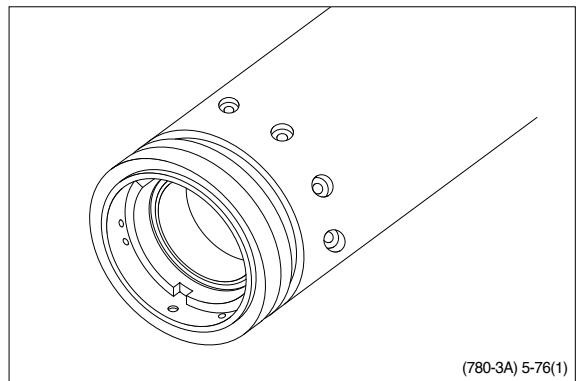

- (4) Press the springs together and push the neutral position springs into place in the sleeve.

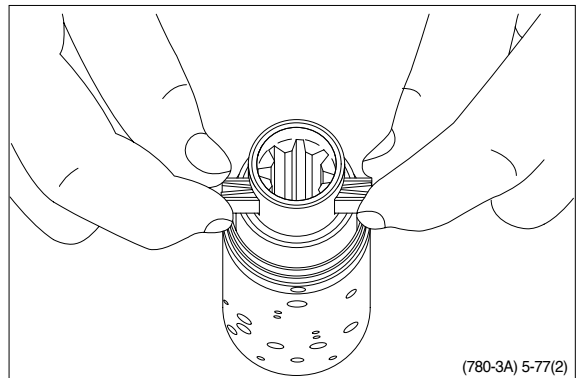

(5) Line up the springs and center them.

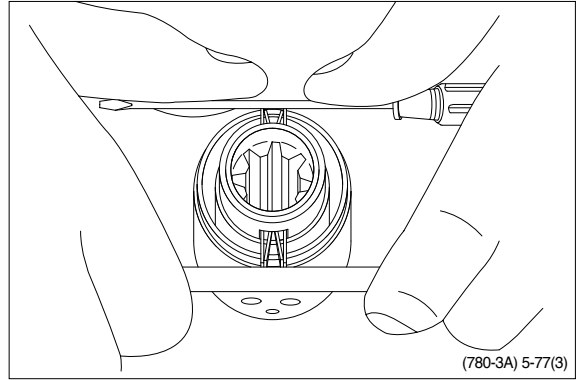

(6) Guide the ring down over the sleeve.  
The ring should be able to move-free of the springs.

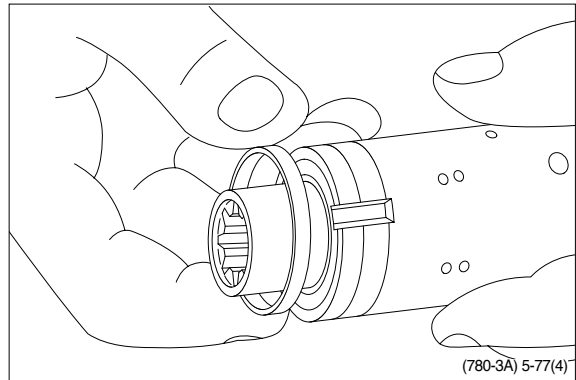

(7) Fit the cross pin into the spool / sleeve.

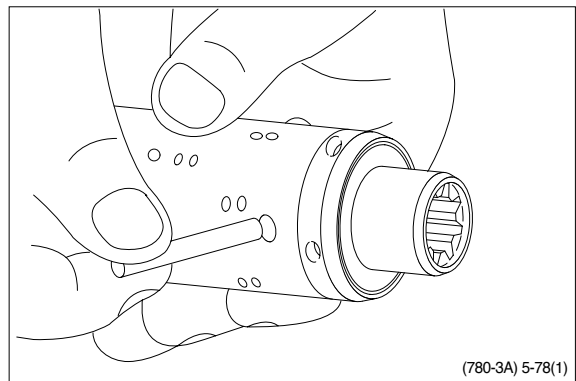

(8) Fit bearing races and needle bearing.  
(See the next page)

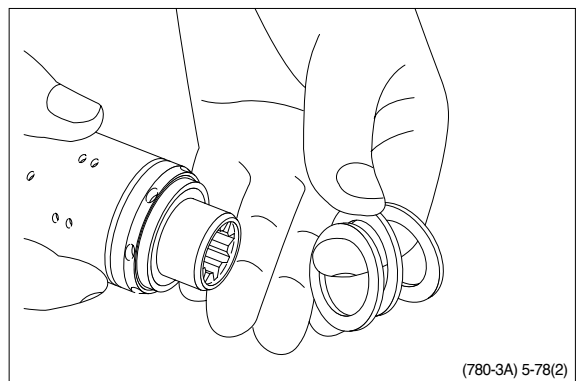

### Assembly pattern for standard bearings

- 1 Outer bearing race
- 2 Needle bearing
- 3 Inner bearing race
- 4 Spool
- 5 Sleeve

\* The inside chamfer on the inner bearing race must face the inner spool.

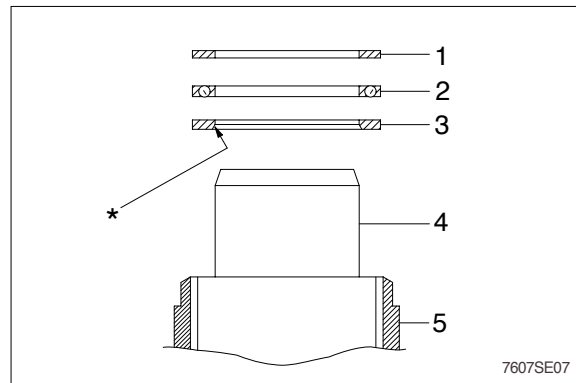

### Installation instruction for O-ring

- (9) Turn the steering unit until the bore is horizontal. Guide the outer part of the assembly tool into the bore for the spool / sleeve.

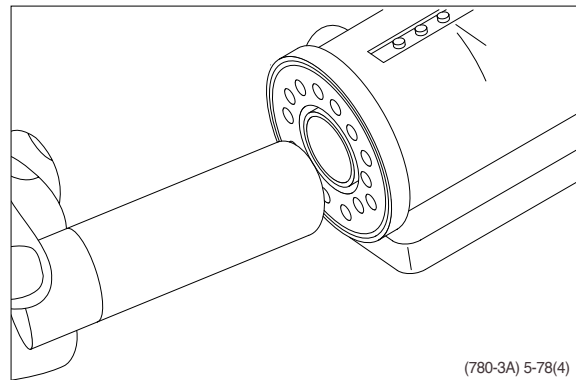

- (10) Grease O-ring with hydraulic oil and place them on the tool.

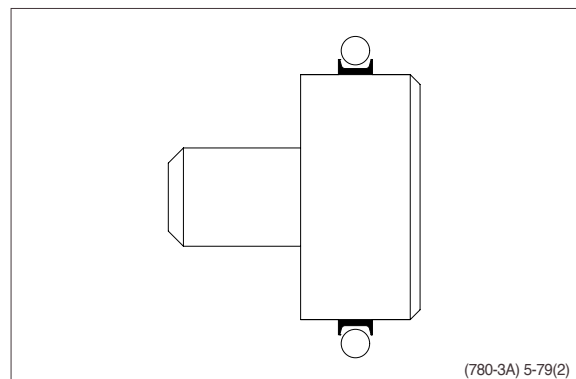
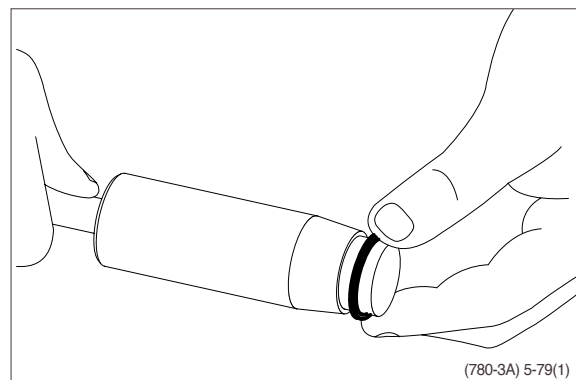

- (11) Hold the outer part of the assembly tool in the bottom of the steering unit housing and guide the inner part of the tool right to the bottom.

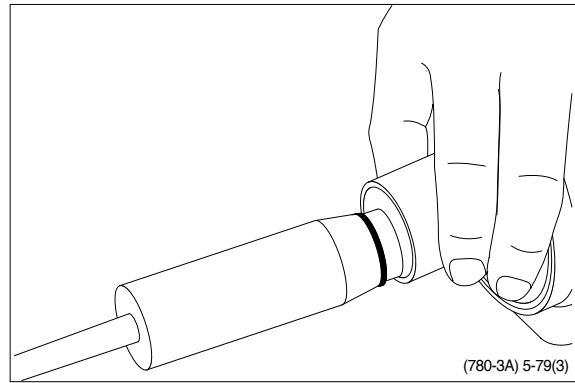

- (12) Press and turn the O-ring into position in the housing.

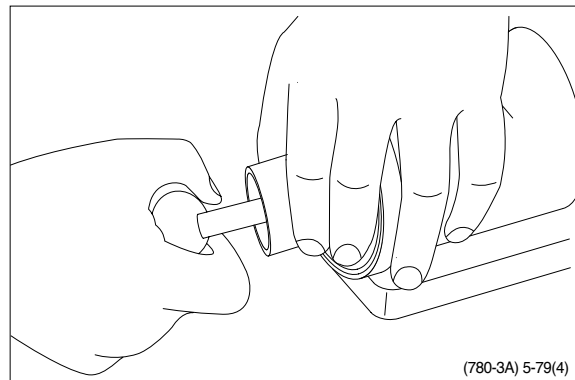

- (13) Draw the inner and outer parts of the assembly tool out of the steering unit bore, leaving the guide from the inner part in the bore.

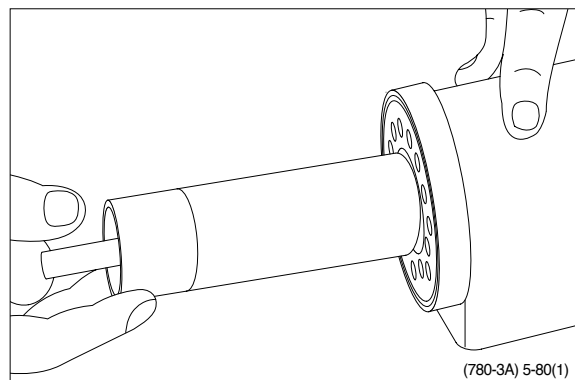

#### **Installation instructions for lip seal**

- (14) Lubricate the lip seal with hydraulic oil and place it on the assembly tool.

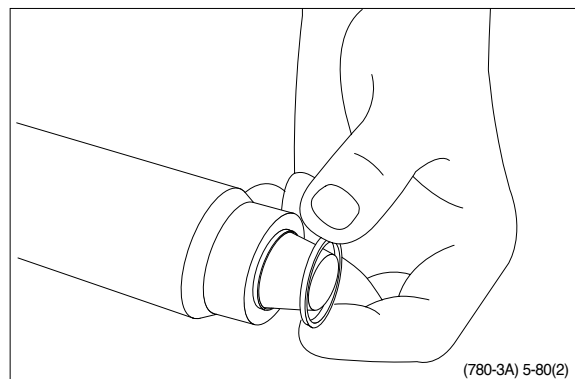

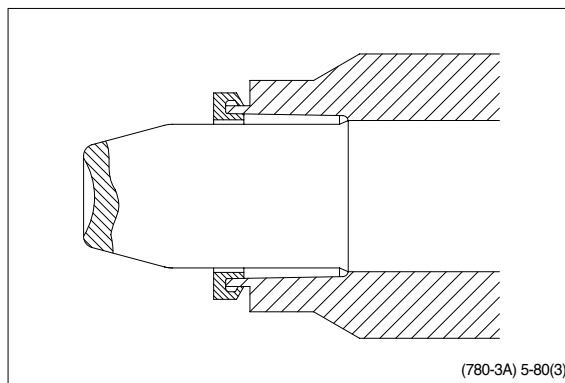

(15) Guide the assembly tool right to the bottom.

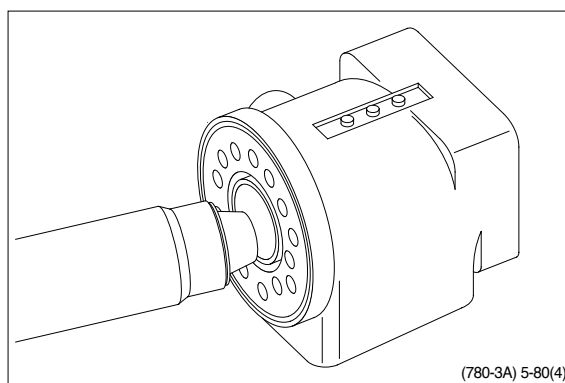

(16) Press and turn the lip seal into place in the housing.

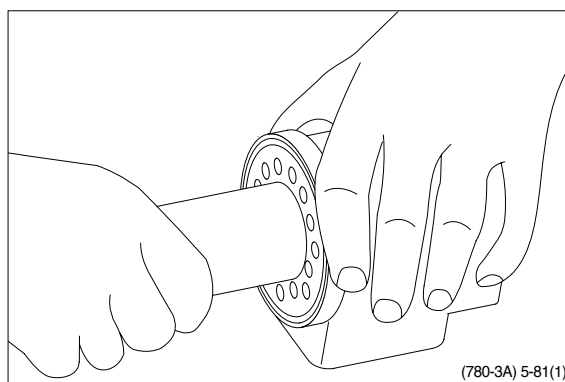

(17) With a light turning movement, guide the spool and sleeve into the bore.  
Fit the spool set holding the cross pin horizontal.

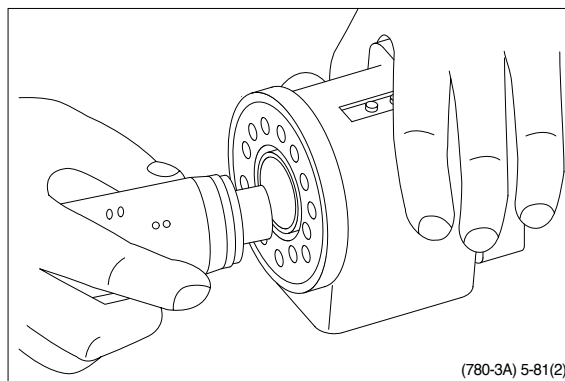

(18) The spool set will push out the assembly tool guide. The O-ring are now in position.

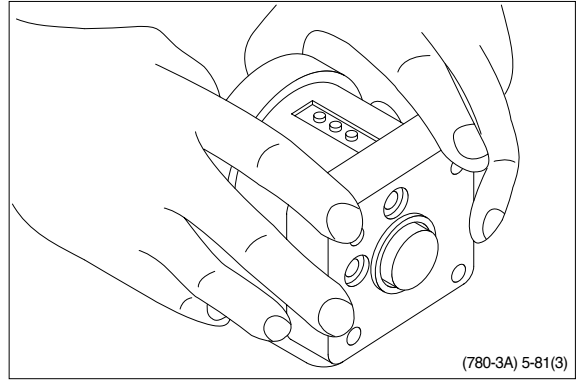

(19) Turn the steering unit until the bore is vertical again. Put the check valve ball into the hole indicated by the arrow.

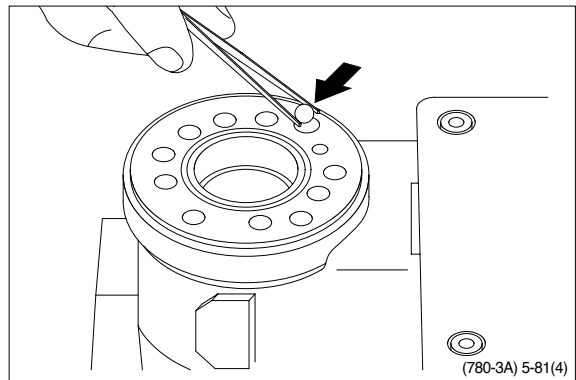

(20) Screw the threaded bush lightly into the check valve bore. The top of the bush must lie just below the surface of the housing.

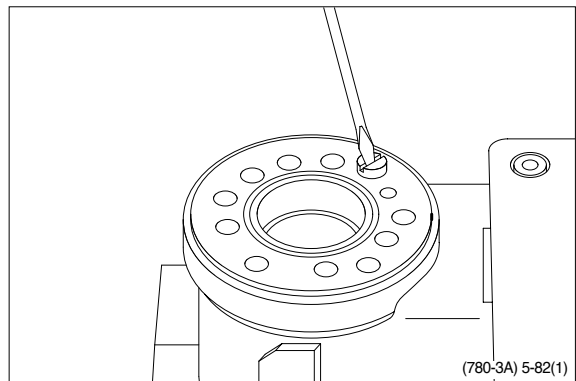

(21) Grease the O-ring with mineral oil approx. viscosity 500 cSt at 20°C.

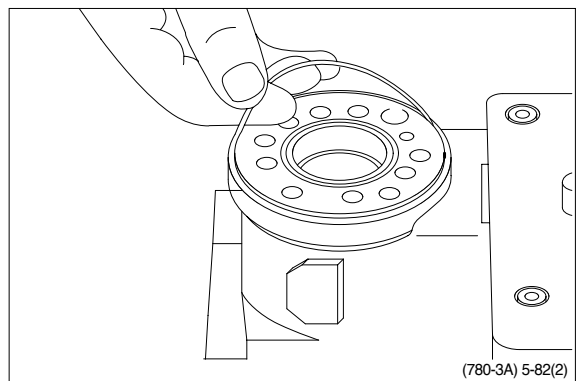

(22) Place the distributor plate so that the channel holes match the holes in the housing.

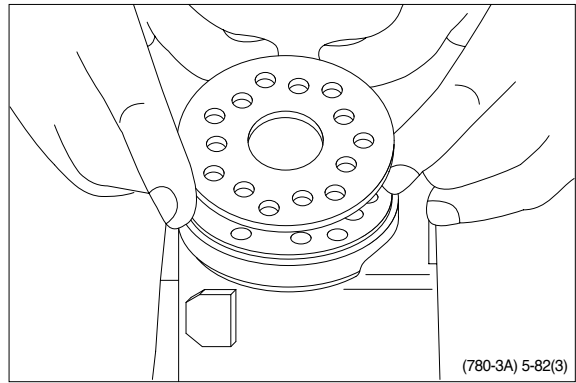

(23) Guide the cardan shaft down into the bore so that the slot is parallel with the connection flange.

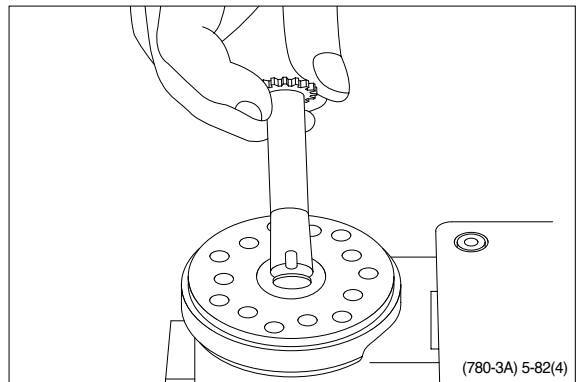

(24) Place the cardan shaft as shown - so that it is held in position by the mounting fork.

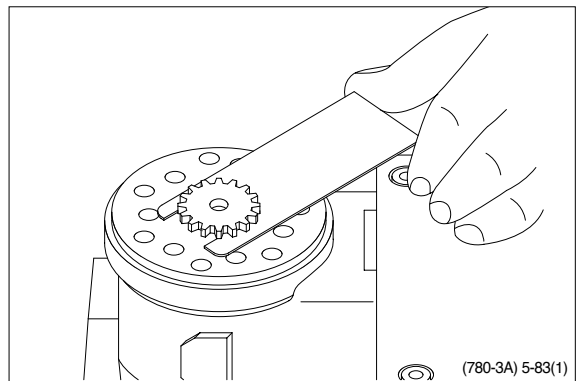

(25) Grease the two O-rings with mineral oil approx. viscosity 500 cSt at 20°C and place them in the two grooves in the gear rim. Fit the gearwheel and rim on the cardan shaft.

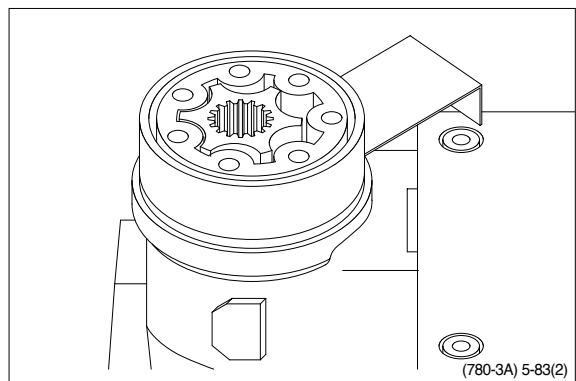

**(26) Important**

Fit the gearwheel (Rotor) and cardan shaft so that a tooth base in the rotor is positioned in relation to the shaft slot as shown.

Turn the gear rim so that the seven through holes match the holes in the housing.

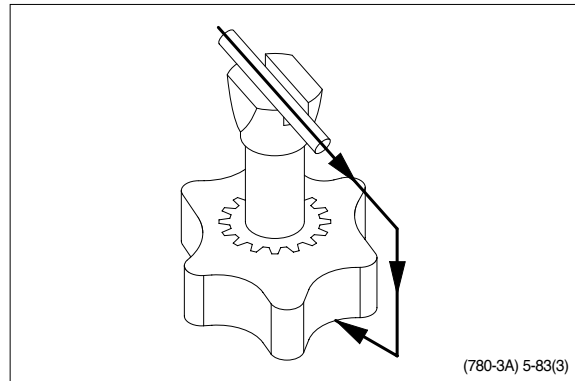

**(27) Fit the spacer, if any.**

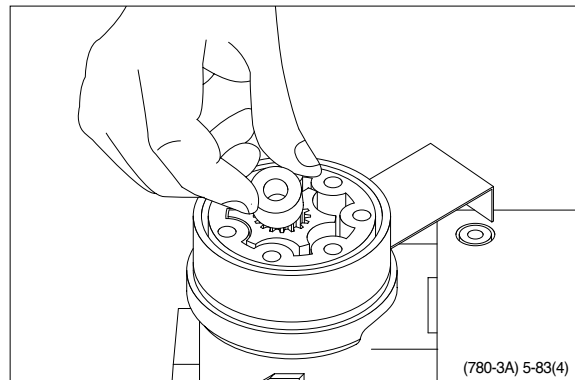

**(28) Place the end cover in position.**

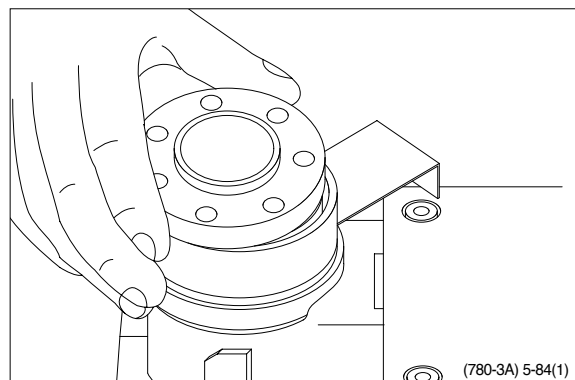

**(29) Fit the special screw with washer and place it in the hole shown.**

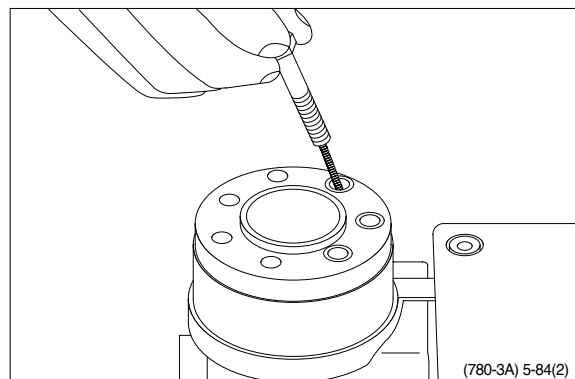

(30) Fit the six screws with washers and insert them. Cross-tighten all the screws and the rolled pin.

- Tightening torque :  $3.1 \pm 0.6 \text{kgf} \cdot \text{m}$   
( $22.4 \pm 4.3 \text{lb} \cdot \text{ft}$ )

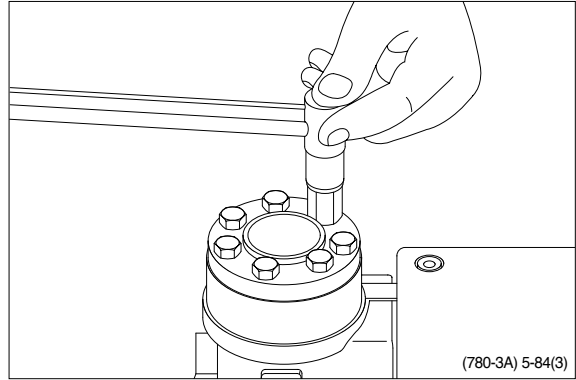

(31) Place the dust seal ring in the housing.

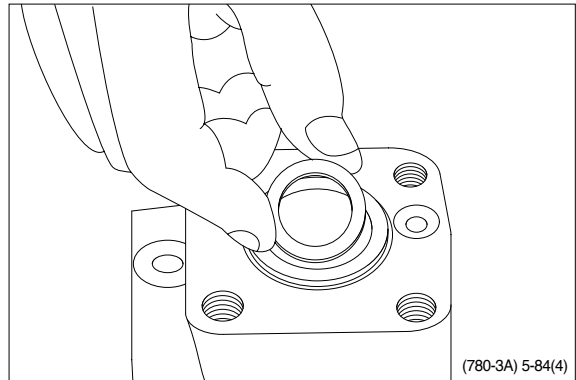

(32) Fit the dust seal ring in the housing using special tool and a plastic hammer.

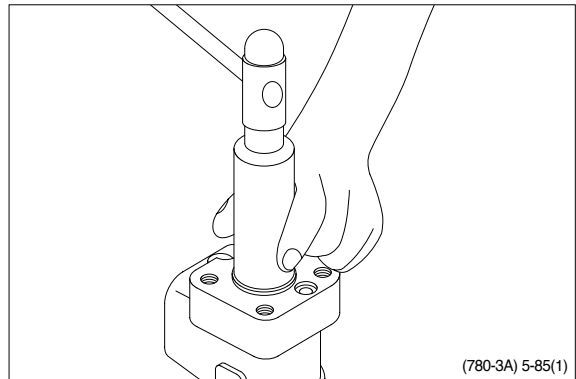

(33) Press the plastic plugs into the connection ports.  
Do not use a hammer!

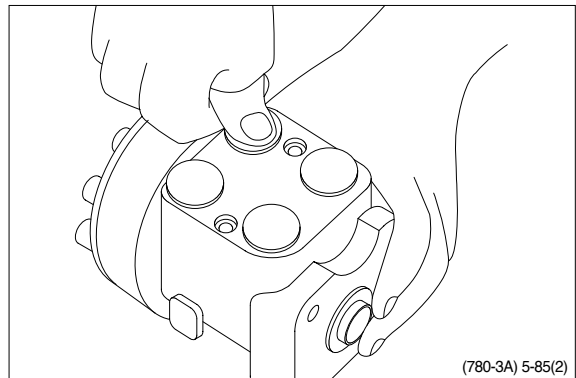

## 2. STEERING CYLINDER

### 1) STRUCTURE

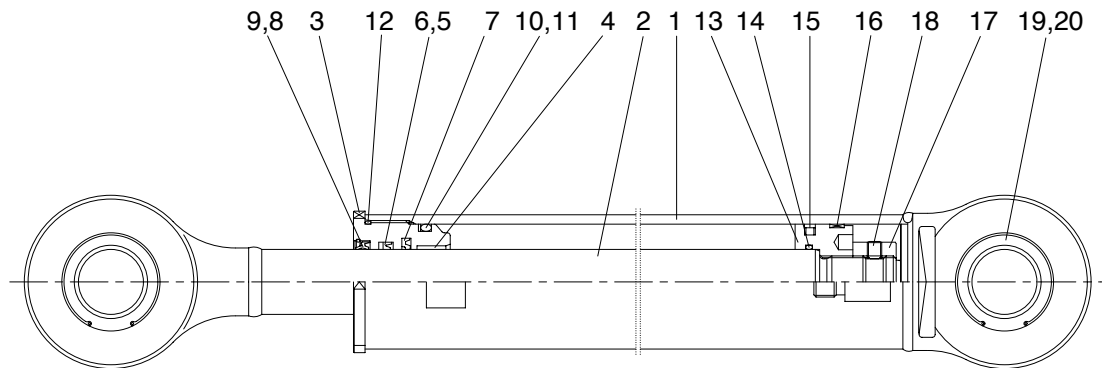

7607SE05

- |   |               |    |              |    |                   |
|---|---------------|----|--------------|----|-------------------|
| 1 | Tube assembly | 8  | Dust wiper   | 15 | Piston seal       |
| 2 | Rod assembly  | 9  | Snap ring    | 16 | Wear ring         |
| 3 | Gland         | 10 | O-ring       | 17 | Piston nut        |
| 4 | Bushing       | 11 | Back up ring | 18 | Set screw         |
| 5 | Rod seal      | 12 | O-ring       | 19 | Spherical bearing |
| 6 | Back up ring  | 13 | Piston       | 20 | Retaining ring    |
| 7 | Buffer ring   | 14 | O-ring       |    |                   |

## 2) TOOLS AND TIGHTENING TORQUE

### (1) Tools

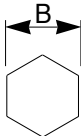
Tool name	B	Remark
L-wrench	5	
Spanner	36	
Wrench	For gland	
(-) Driver	Small and large sizes	
Torque wrench	Capable of tightening with the specified torques	

### (2) Tightening torque

Part name	Item	Size	Torque	
			kgf · m	lbf · ft
Gland	3	M85 × 3	75 ± 8	542 ± 58
Piston	13	M36 × 3	50 ± 5	362 ± 36
Piston nut	17	M36 × 3	75 ± 8	542 ± 58
Set screw	18	M10 × 1.5	5.4 ± 0.5	39 ± 3.6

### 3) DISASSEMBLY

#### (1) Remove cylinder head and piston rod

Hold the clevis section of the tube in a vise.

Use mouth pieces so as not to damage the machined surface of the cylinder tube. Do not make use of the outside piping as a locking means.

Pull out piston rod(2) about 200mm (7.8in). Because the piston rod is rather heavy, finish extending it with air pressure after the oil draining operation.

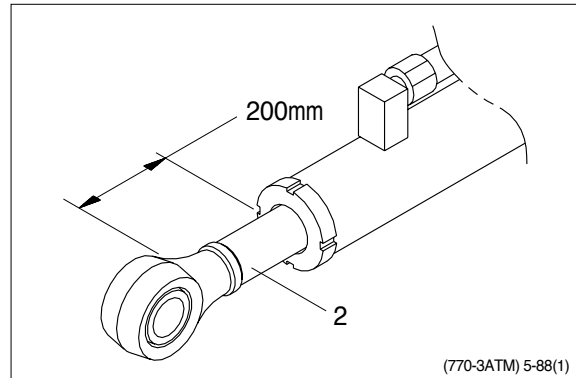

Loosen and remove the gland(3).

Cover the extracted piston rod(2) with rag to prevent it from being accidentally damaged during operation.

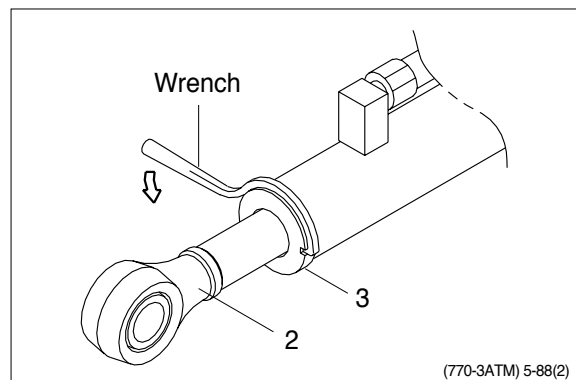

Draw out gland(3) and piston rod (2) assembly together from cylinder tube(1). Since the piston rod assembly is heavy in this case, lift the tip of the piston rod(2) with a crane or some means and draw it out. However, when piston rod(2) has been drawn out to approximately two thirds of its length, lift it in its center to draw it completely.

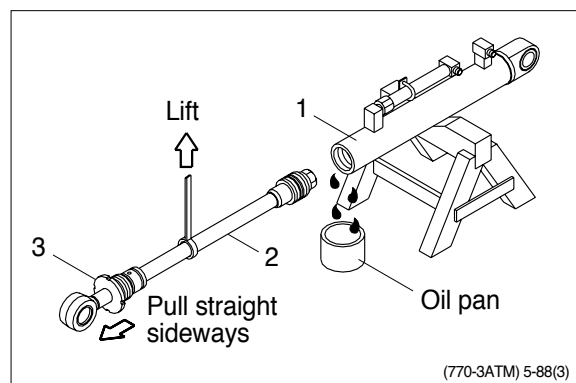

Note that the plated surface of piston rod(2) is to be lifted. For this reason, do not use a wire sling and others that may damage it, but use a strong cloth belt or a rope.

Place the removed piston rod assembly on a wooden V-block that is set level. Cover a V-block with soft rag.

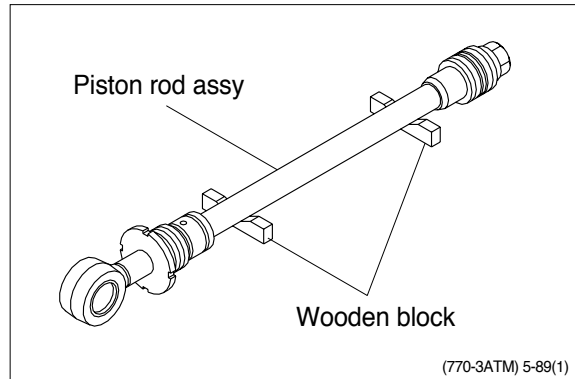

**(2) Remove piston and gland assembly**

Remove the set screw(18).  
 Remove the piston nut(17).  
 Remove piston assembly(13) and O-ring (14).

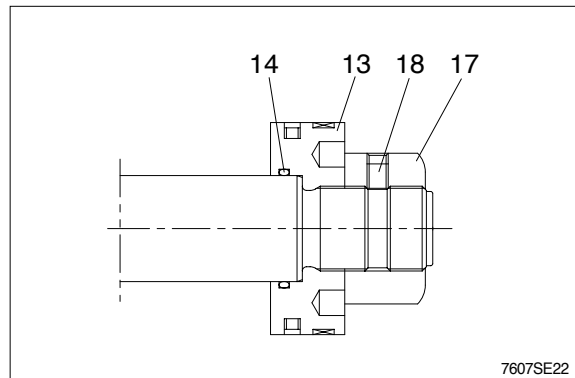

Remove the gland(3) assembly from piston rod(2).

If it is too heavy to move, move it by striking the flanged part of gland(3) with a plastic hammer.

Pull it straight with gland assembly lifted with a crane.

Exercise care so as not to damage the lip of rod bushing(4) and packing (5,6,7,8,9) by the threads of piston rod(2).

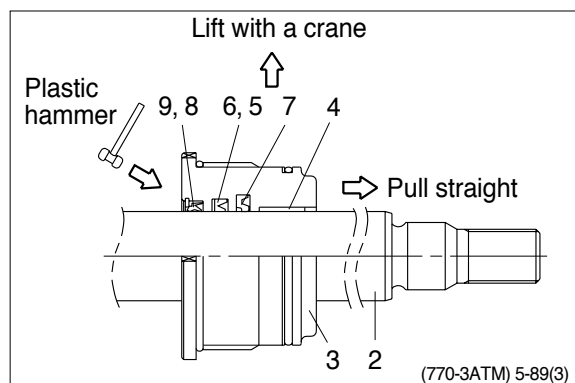

**(3) Disassemble the piston assembly**

Remove wear ring(16).  
Remove piston seal(15).  
Exercise care in this operation not to damage the grooves.

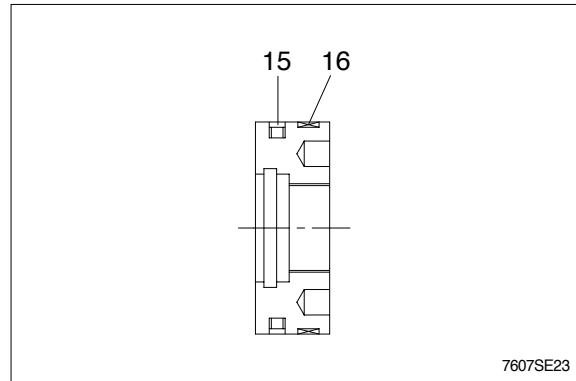

**(4) Disassemble gland assembly**

Remove back up ring(11), and O-ring (10).  
Remove O-ring (12).  
Remove snap ring(9) and dust wiper(8).  
Remove back up ring(6), rod seal(5) and buffer ring(7).  
Exercise care in this operation not to damage the grooves.  
Do not remove seal and ring, if does not damaged.

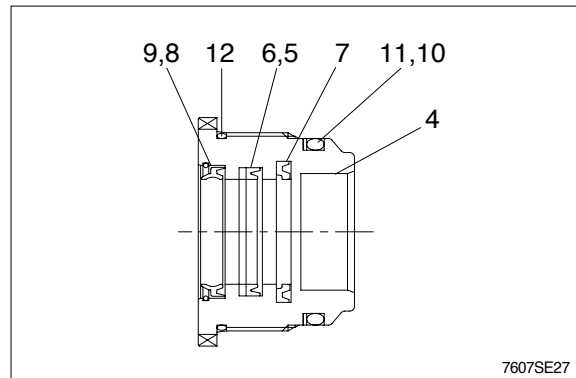

#### 4) ASSEMBLY

##### (1) Assemble gland assembly

Check for scratches or rough surfaces if found smooth with an oil stone.

Coat the inner face of gland(3) with hydraulic oil.

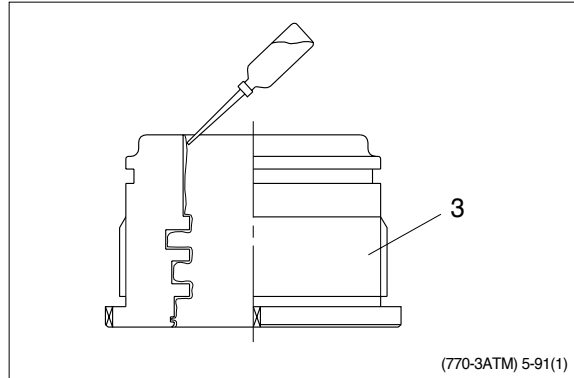

Coat dust wiper(8) with grease and fit dust wiper(8) to the bottom of the hole of dust wiper.

At this time, press a pad metal to the metal ring of dust seal.

Fit snap ring(9) to the stop face.

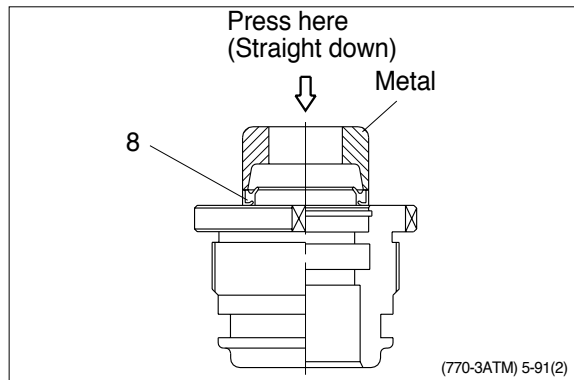

Fit back up ring(6) and rod seal(5), and buffer ring(7) to corresponding grooves, in that order.

Coat each packing with hydraulic oil before fitting it.

Insert the backup ring until outside of it is inserted into groove.

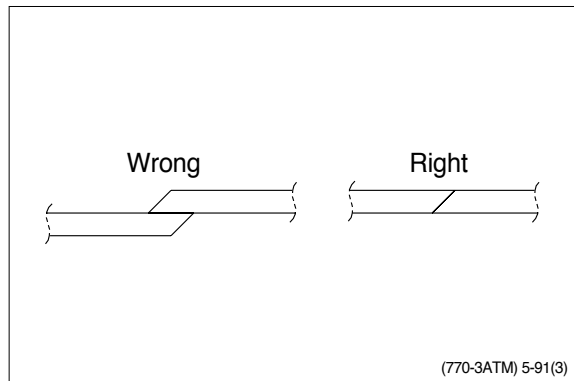

Rod seal(5) has its own fitting direction.

Therefore, confirm it before fitting them.

Fitting rod seal(5) up side down may damage its lip. Therefore check the correct direction that is shown in figure.

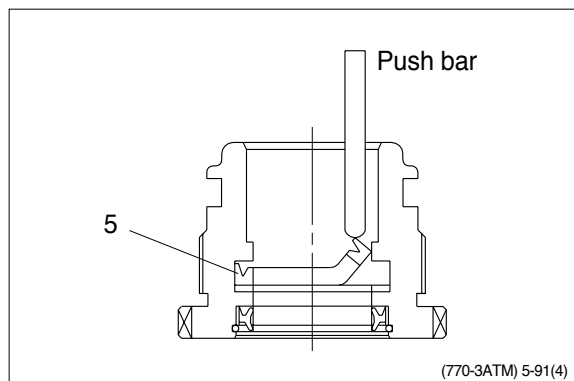

Fit back up ring(11) to gland (3).  
 Put the backup ring in the warm water of 30~50 ℃.  
 Fit O-ring(10) to gland(3).

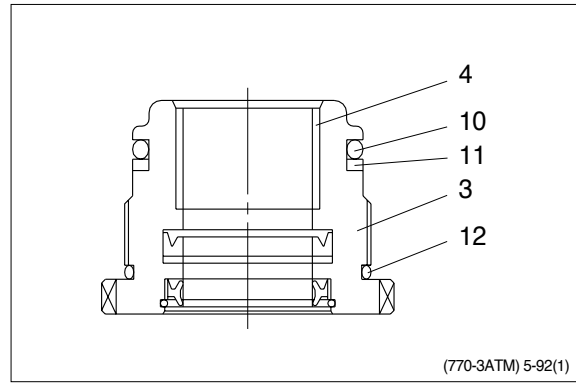

**(2) Assemble piston assembly**

Check for scratches or rough surfaces.  
 If found smooth with an oil stone.  
 Coat the outer face of piston(13) with hydraulic oil.

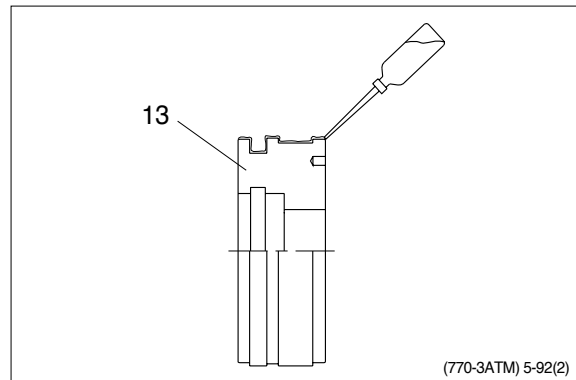

Fit piston seal(15) to piston.  
 Put the piston seal in the warm water of 60~100 ℃ for more than 5 minutes.  
 After assembling the piston seal, press its outer diameter to fit in.

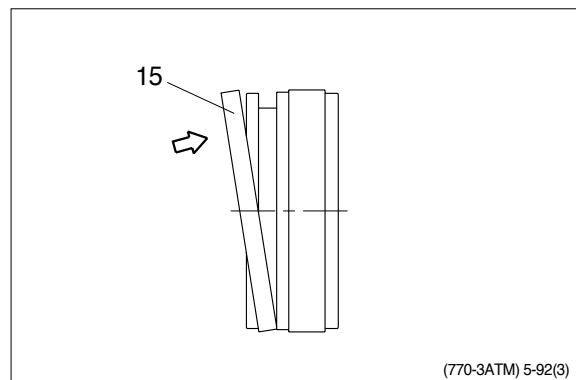

Fit wear ring(16) to piston(13).  
 Fit O-ring(14) to piston(13).

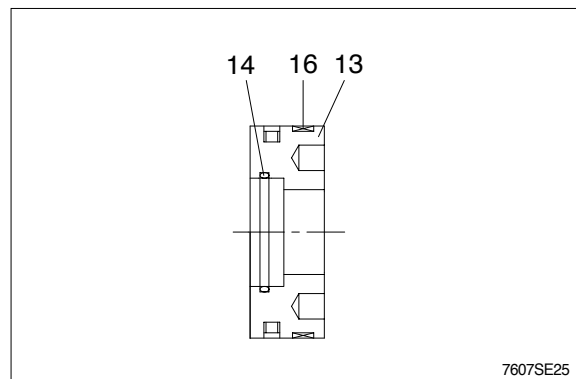

### (3) Install piston and gland assembly

Fix the piston rod assembly to the work bench.

Apply hydraulic oil to the outer surface of piston rod(2), the inner surface of piston and gland.

Insert gland assembly to piston rod(2).

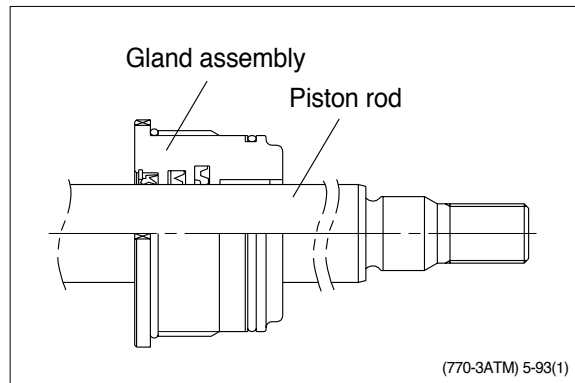

Fit piston assembly to piston rod.

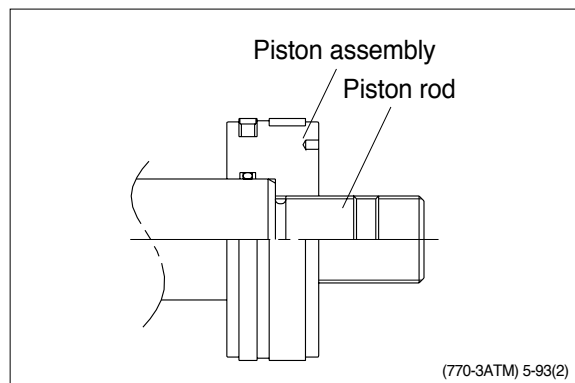

Tighten piston nut(17) to piston rod(2).

- Tightening torque :  $75 \pm 8 \text{ kgf} \cdot \text{m}$   
( $542 \pm 58 \text{ lbf} \cdot \text{ft}$ )

Tighten set screw(18) to piston nut(17).

- Tightening torque :  $5.4 \pm 0.5 \text{ kgf} \cdot \text{m}$   
( $39 \pm 3.6 \text{ lbf} \cdot \text{ft}$ )

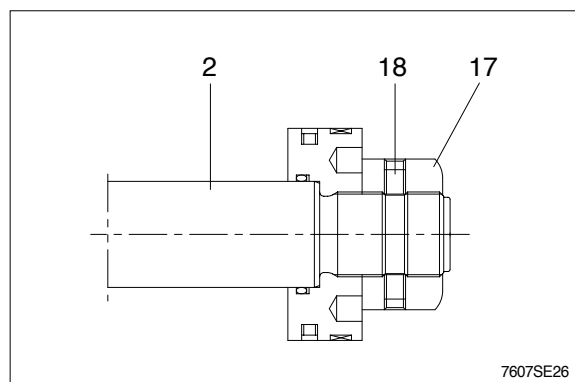

#### (4) Overall assemble

Place a V-block on a rigid work bench.  
Mount the cylinder tube assembly(1) on it  
and fix the assembly by passing a bar  
through the clevis pin hole to lock the  
assembly.

Insert the piston rod assembly in to the  
cylinder tube assembly, while lifting and  
moving the piston rod assembly with a  
crane.

Be careful not to damage piston seal by  
thread of cylinder tube.

Match the bolts holes in the cylinder head  
flange to the tapped holes in the cylinder  
tube assembly and tighten socket bolts to  
a specified torque.

Refer to the table of tightening torque.

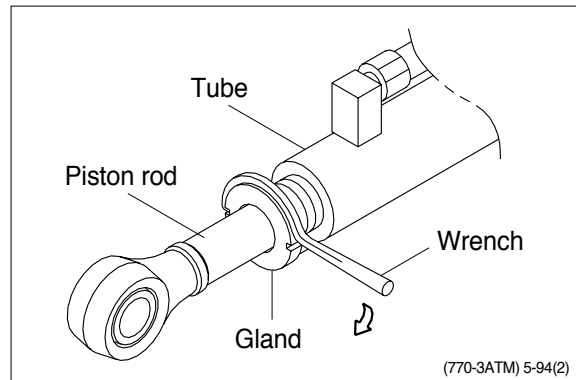
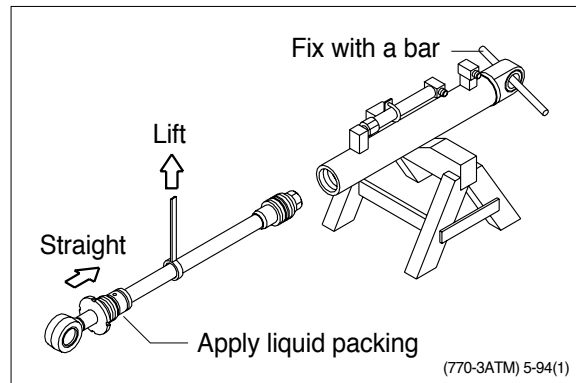

### 3. CENTER PIVOT PIN

#### 1) CONSTRUCTION

Figure shows the construction of the center pivot pin assembly. This assembly serves to connect the front frame with the rear frame; two sets of assemblies are provided, one each for the upper and lower parts. The numbers in parentheses following the parts name denote the item numbers shown in the figure in the disassembly and assembly procedures.

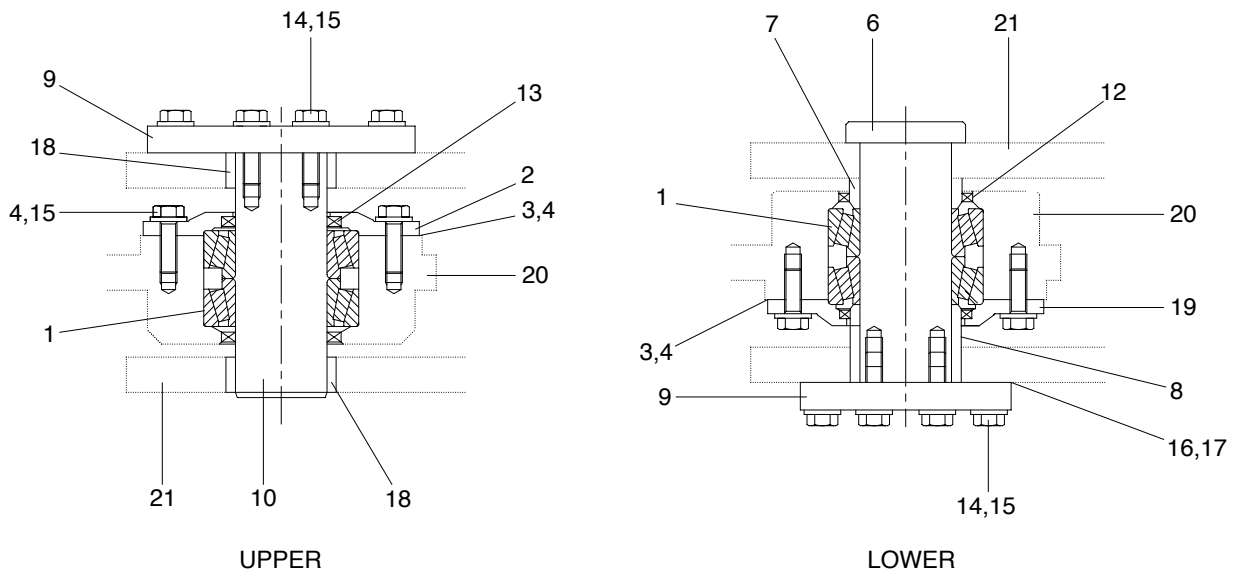

7707SE13

1	Bearing	9	Plate	16	Shim(0.1T)
2	Cover	10	Pin	17	Shim(0.5T)
3	Shim(0.1T)	12	Seal	18	Bushing
4	Shim(0.5T)	13	Seal	19	Cover
6	Pin	14	Hexagon bolt	20	Front frame
7	Collar	15	Hardened washer	21	Rear frame
8	Collar				

## 2) DISASSEMBLY

After supporting the front frame and the rear frame as horizontally as possible using wood blocks and jacks, disassemble as follows: In order to facilitate the disassembly/assembly of the center pivot pins, remove the drive shaft, hydraulic line and steering cylinder first.

- (1) Maintain the horizontal level of front frame(20) and rear frame(21), and then remove hexagon bolt(14) and plate(9).
- (2) Take out upper pin(10) to the downside using a metal punch.

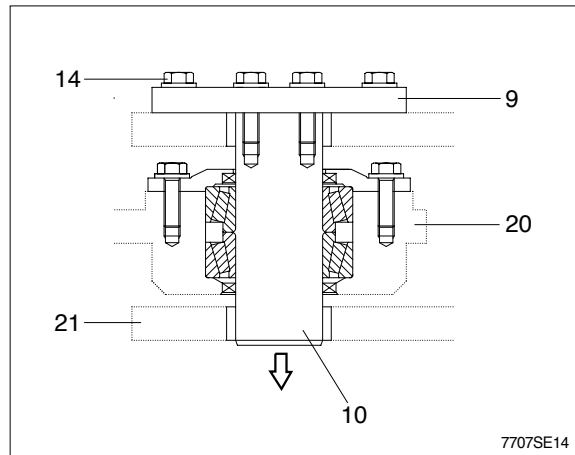

- (3) Maintain the front frame horizontal level, remove hexagon bolts(14) and then remove the plate(9) and shims(16,17).
- (4) Take out lower pin(6) to the upside using a metal punch carefully.
- (5) Jack up or lifting the front frame(20) slightly, the collar(8) protrudes over the rear frame. Remove the collar(8).
- (6) Lift the frame by passing the slinging wire rope at four positions of front frame, in order to separate it from the rear frame.
- (7) Support the front frame safely.

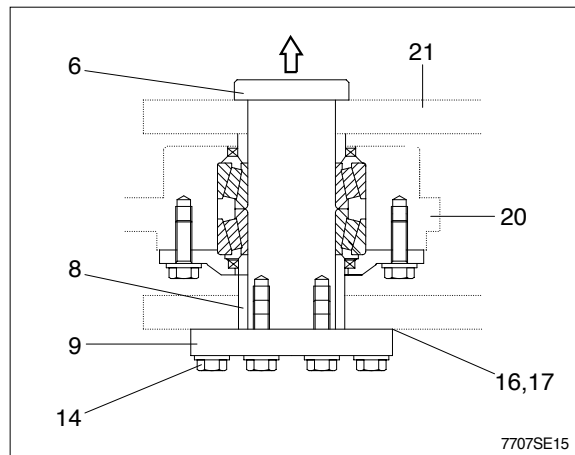

- (8) Remove bolt(14) and then take out cover(2) and shims(3,4).
- (9) Take out dust seal(13) from the cover(2).
- (10) Remove the bearing(1), and dust seal(13).

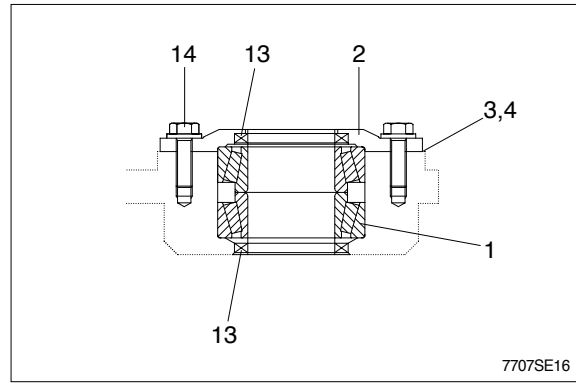

- (11) Remove bolt(14) and then take out cover(19) and shims(3,4).
- (12) Take out the dust seal(12) from the cover(19).
- (13) Remove the bearing(1), collar(7) and dust seal(12).

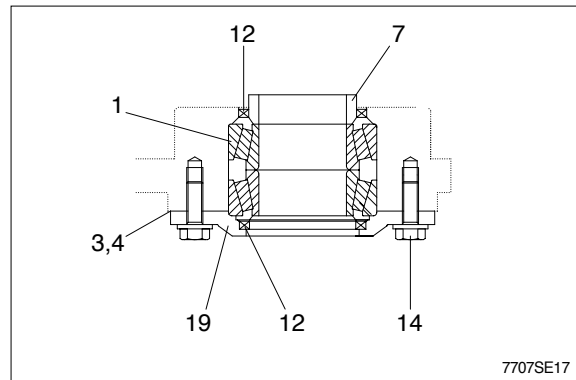

### 3) INSPECTION

- (1) Check the bearing sliding surface for excessive wear, scorching or scratches; replace if necessary.
- (2) Replace all dust seals(12,13) with new ones.
- (3) Grind any pins(6, 10) dented with an oilstone or replace any pins abrasive excessively.
- (4) Check inside cover(2, 19) and collar(7, 8) for dents or scratches; if any damage is found, correct with a grinder or replace.
- (5) The serviceable limit of pins and bushings is shown in the table below.

Unit : mm

Item No.	Name	Std dimension	Serviceable limit			Remedy
			Outer dia	Inner dia	Clearance	
6, 10	Pin	90	89.5	-	0.8	Replace
1	Tapered roller bearing		-	90.5		
7, 8	Collar		-	90.5		
12, 13	Dust seal	When removed			Replace	

#### 4) ASSEMBLY

Assemble the center pivot group by reversing the order of disassembly while paying close attention to the following.

- (1) Put the dust seal(12,13) into cover(2, 19) and front frame(20).  
Apply grease to the lip of the dust seal. Insert the dust seal so that the dust seal lip faces out and punch four places on the outer circumference of the seal to lock it.
- (2) Lower the temperature of the lower bearing cup to  $-75 \pm 5^{\circ}\text{C}$  ( $-103 \pm 9^{\circ}\text{F}$ ) and install it to front frame until it contacts the bottom of the frame.
- (3) Coat lightly with oil and install lower bearing in bore in front frame. Coat lightly with oil and install upper bearing in bore in upper front frame.
- (4) Position the upper cover(2) and hold in place with bolt(14). At this time, adjust shims(3,4) to press the shoulder of bearing(1) against retainer.
  - Shim thickness : 0.1mm, 0.5mm
- (5) Apply grease to lower collar(8) and insert it to the lower of roller bearing.
- (6) After setting the bearing so that its upper surface is horizontal, tighten the bolt.  
After tightening, confirm that tapered roller bearing moves lightly ; if does not move smoothly, add shims(3,4).
  - Tightening Torque : 25.4~34.2kgf · m(184~247lbf · ft)
- (7) Move the front frame and join it to the rear frame so that match the pin hole at the center.
- (8) Apply grease to pin(10), bushing(18) and insert it into tapered roller bearing(1).
- (9) Apply grease to lower collar(8) and insert it to the lower of roller bearing through rear frame(21).
- (10) Apply grease to pin(6) and insert it into tapered roller bearing(1).
- (11) Position the plate(9) and hold in place with bolt(14).
  - Tightening Torque : 25.4~34.2kgf · m(184~247lbf · ft)
  - Apply locktite #242.
- (12) Before tightening bolt(14), adjust shims(16,17) in order to control the clearance between the plate(9) and rear frame(21).
  - Shim thickness : 0.1mm, 0.5mm
  - Tightening Torque : 9.8~15.8kgf · m(70.9~114lbf · ft)
  - Apply Locktite #242.

## 5) TROUBLESHOOTING

Trouble	Probable cause	Remedy
Shock is felt when steering	Capscrew for fixing steering valve is loose	Retighten
	Faulty center pivot pin mounting bolts	Retighten
	Center pivot pins have worn out	Readjust or replace
	Faulty hydraulic system	See hydraulic system
Shock is felt when moving backward or forward	Fault fixing of connecting capscrews	Retighten
	Center pins have worn out	Readjust or replace
	Bearings of support unit have worn out	Retighten
	Drive shaft damaged	See drive system
	Faulty transmission	See transmission system