

GROUP 4 DISASSEMBLY AND ASSEMBLY

1. CONTROL VALVE

1) DISASSEMBLY

- (1) Illustration on the right shows the complete control unit.

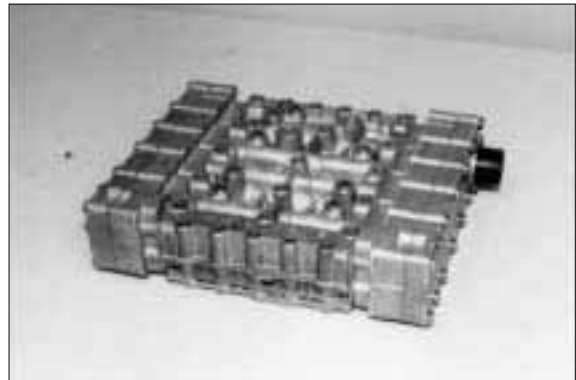

73073CV001

- (2) Mark the installation position of the different covers, the housing and cable harness with the valve housing.

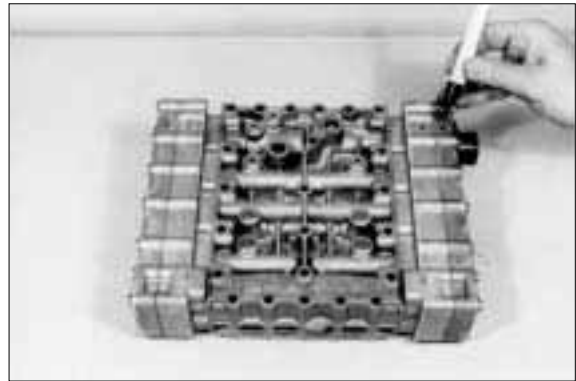

73073CV002

- (3) Loosen socket head screws.
Separate duct plate, 1st gasket, intermediate plate and 2nd gasket from the valve housing.
Box spanner 5873 042 002

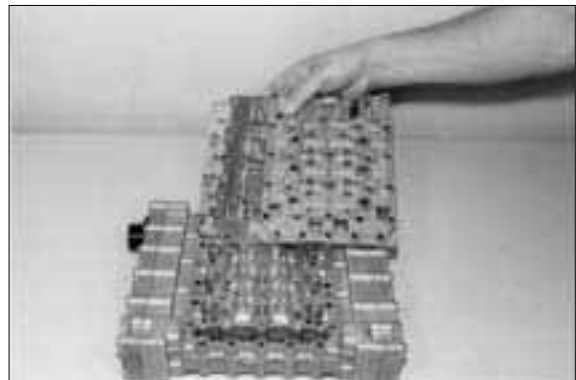

73073CV003

- (4) Remove retaining clip.

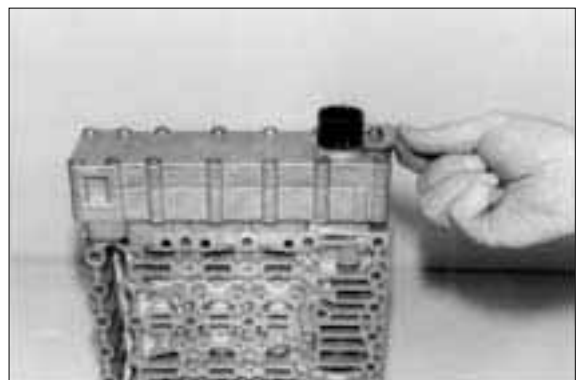

73073CV004

- (5) Loosen socket head screws.
Separate cover from housing and cable harness.
Box spanner 5873 042 002

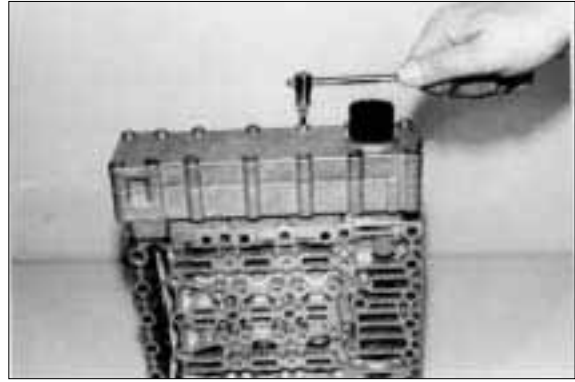

73073CV005

- (6) Disassemble opposite cover.
Disconnect pressure regulator and remove cable harness.

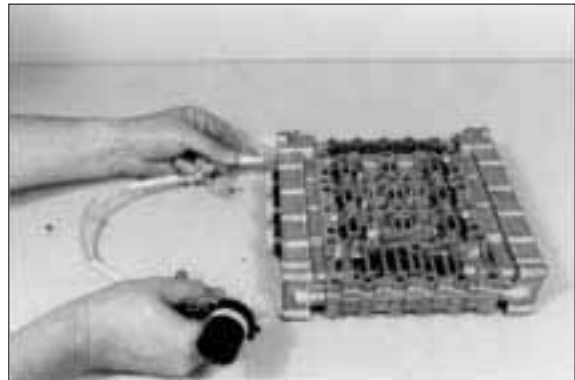

73073CV006

- (7) Loosen socket head screws, remove fixing plate and pressure regulators(3EA).
Box spanner 5873 042 002



73073CV007

- (8) Loosen two socket head screws and locate housing provisionally, using adjusting screws(Housing is under spring preload).
Now, loosen remaining socket head screws.
Box spanner 5873 042 002
Adjusting screws 5870 204 036

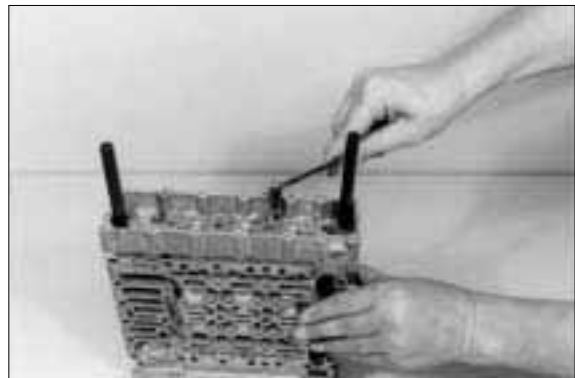

73073CV008

- (9) Separate housing from valve housing by loosening the adjusting screws uniformly.
Adjusting screws 5870 204 036

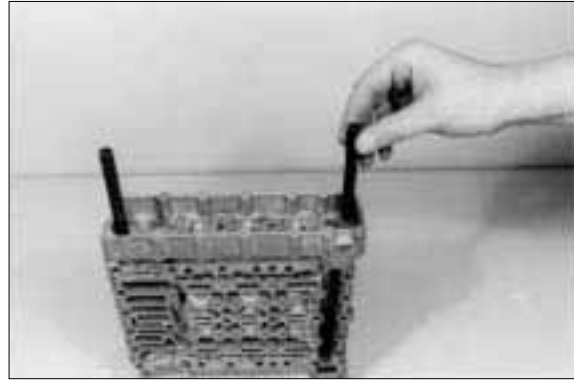

73073CV009

- (10) Remove components.

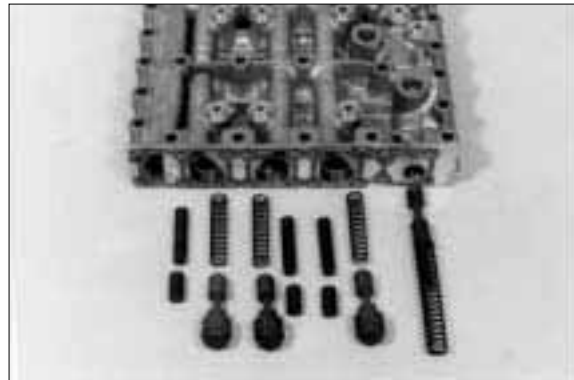

73073CV010

- (11) Remove opposite pressure regulators, housing as well as components according-ly.

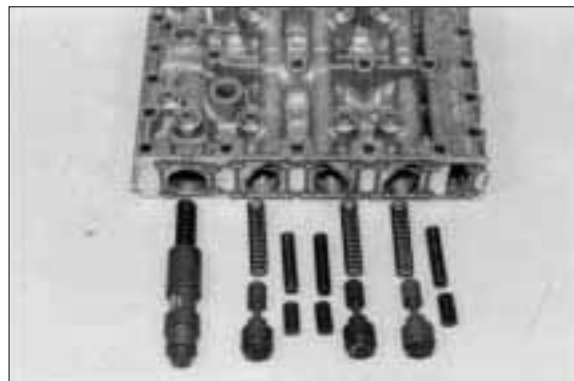

73073CV011

2) ASSEMBLY

- ※ Check all components for damage and renew if necessary.
Prior to the installation, check free travel of all moving parts in the housing.
Spools can be exchanged individually.
Oil the components prior to the assembly.
Insert diaphragms with the concave side showing upward until contact is obtained.
- ※ Installation position, see arrows.

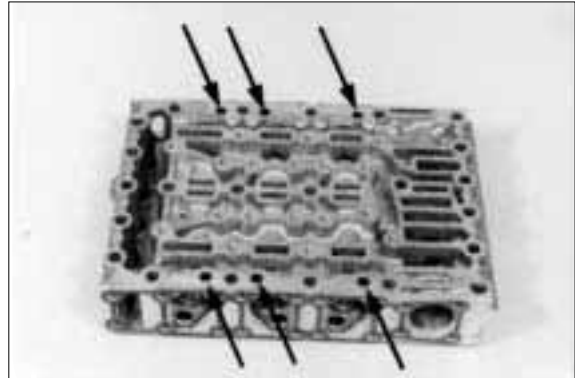

73073CV015

(1) Illustration on the right shows the following components.

- 1 Vibration damper
- 2 Follow-on slide
- 3 Pressure reducing valve

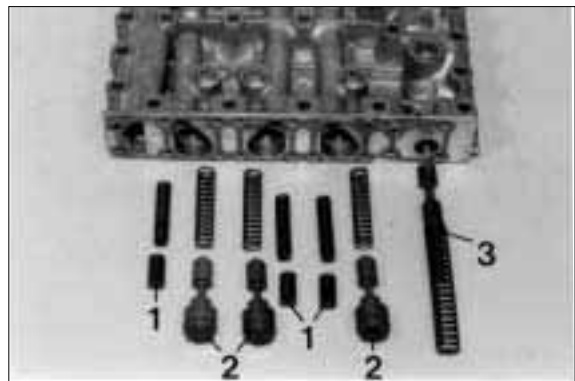

73073CV016

(2) Install components according to figure (1).

- ※ Preload compression spring of the follow-on slides and locate spool provisionally by means of cylindrical pins $\varnothing 5.0\text{mm}$ (Assembly aid), see arrows.

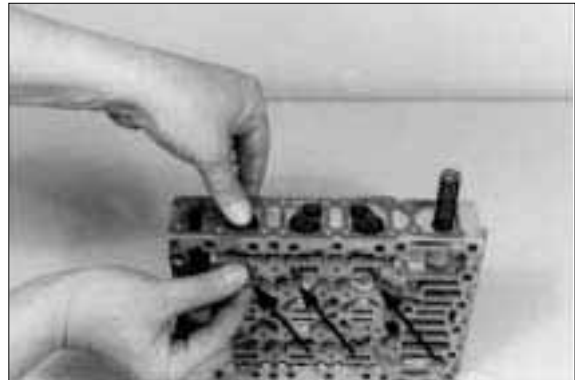

73073CV017

(3) Install two adjusting screws.

Assemble gasket (Arrow 1) and housing cover. Now, position the housing cover uniformly, using adjusting screws, until contact is obtained and remove cylindrical pins (Assembly aid) again (See the next figure).

- ※ Pay attention to the different housing covers. Install recess $\varnothing 15\text{mm}$ (Arrow 2), facing the spring of the pressure reducing valve.

Adjusting screws 5870 204 036

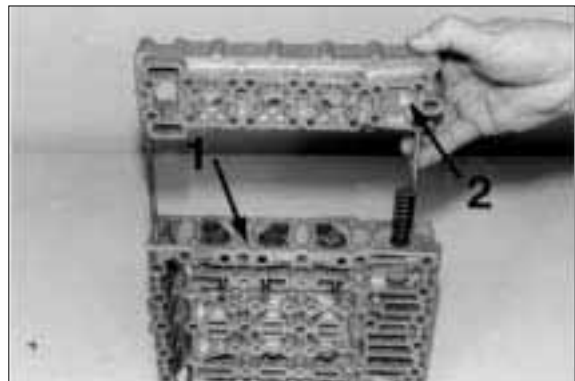

73073CV018

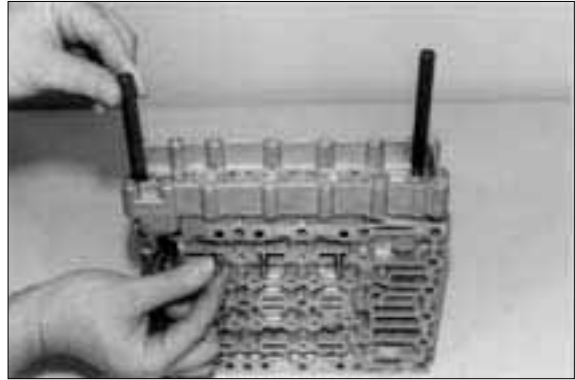

73073CV019

- (4) Fasten housing cover by means of socket head screws.
 · Torque limit : 0.56kgf · m(4.06lbf · ft)
 Box spanner 5873 042 002



73073CV020

- (5) Introduce pressure regulators and fix by means of fixing plates and socket head screws.
 ※ Install fixing plate, with the claw showing downward.
 Pay attention to the radial installation position of the pressure regulators, see figure.
 · Torque limit : 0.56kgf · m(4.06lbf · ft)
 Box spanner 5873 042 002



73073CV021

Pre assemble opposite side

- (6) Illustration on the right shows the following components.
 1 Main pressure valve
 2 Follow on slide
 3 Vibration damper

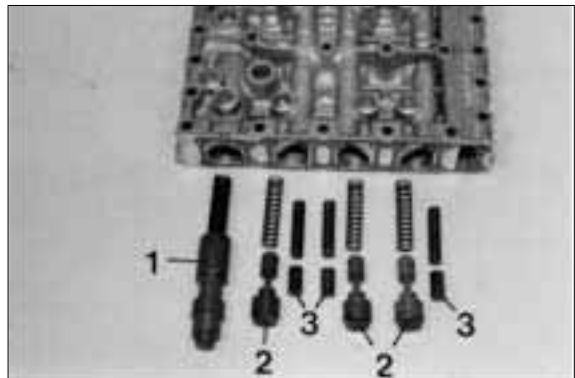

73073CV022

- (7) Install components according to figure (6).
 Preload compression springs of the follow-on slides and locate spool provisionally by means of cylindrical pins \varnothing 5.0mm (Assembly aid), see arrows.
 Install two adjusting screws.
 Assemble gasket (Arrow 1) and housing cover, and position them uniformly against shoulder, using adjusting screws.

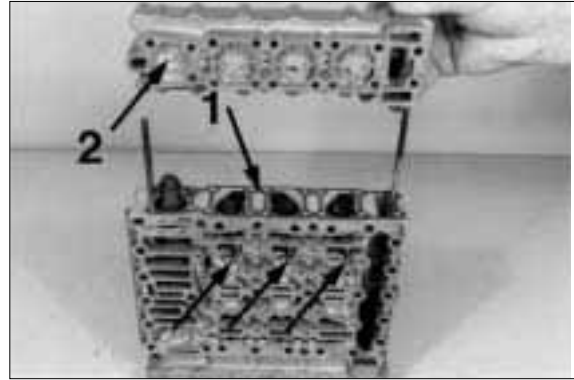

73073CV023

- ※ Pay attention to the different housing covers—install the recess \varnothing 19mm (Arrow 2), facing the main pressure valve.
 Now, fasten housing cover by means of socket head screws.

• Torque limit : 0.56kgf · m (4.06lbf · ft)

Remove cylindrical pins (Assembly aid) again.

Adjusting screws 5870 204 036
 Box spanner 5873 042 002

- (8) Introduce pressure regulators and fix by means of fixing plates and socket head screws.



73073CV024

- ※ Install fixing plates, with the claw showing downward.

Pay attention to the radial installation position of the pressure regulators, see figure.

• Torque limit : 0.56kgf · m (4.06lbf · ft)

Box spanner 5873 042 002

- (9) Introduce cable harness and connect pressure regulators (6EA).

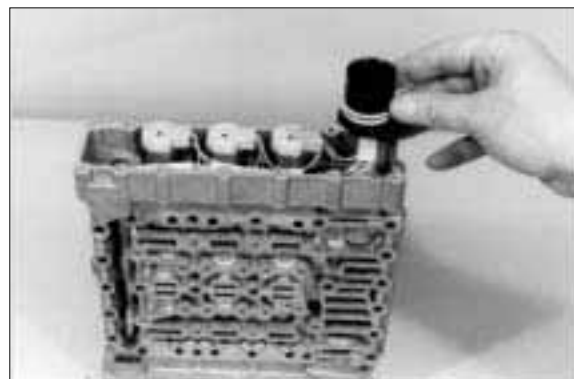

73073CV025

- ※ Pay attention to the installation position of the cable harness, also markings (See figure(2), page 3-80).

(10) Introduce female connector against shoulder, with the groove facing the guide nose of the cover.

Install gasket(Arrow) and fasten cover by means of socket head screws.

· Torque limit : 0.56kgf · m(4.06lbf · ft)

Box spanner 5873 042 002

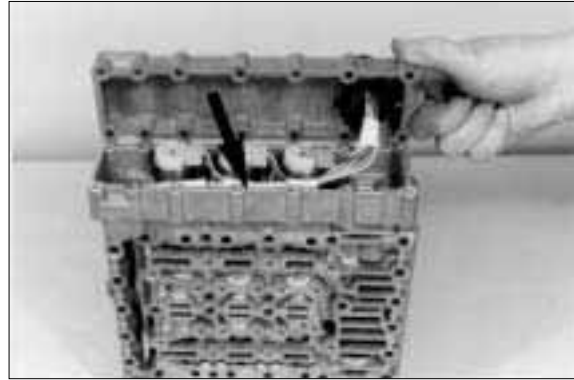

73073CV026

(11) Fix female connector by means of retaining clamp, see figure.

Install opposite cover.



73073CV027

(12) Install two adjusting screws and mount gasket I.

※ Pay attention to the different gaskets, see on the right figure and (15).

Adjusting screws 5870 204 063

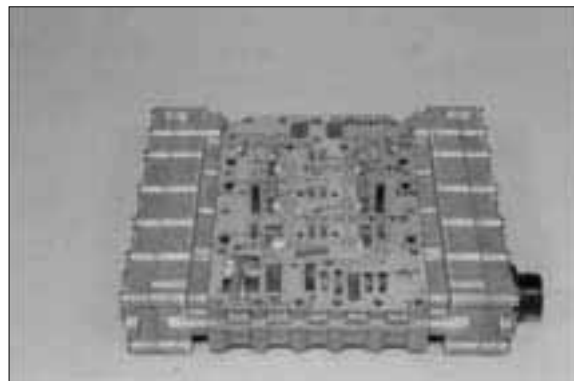

73073CV028

Intermediate plate-Version with screens

(13) Insert screws(6EA) flush mounted into the bore of the intermediate plate, see arrow.

※ Pay attention to the installation position-screws are showing upward(Facing the duct plate).

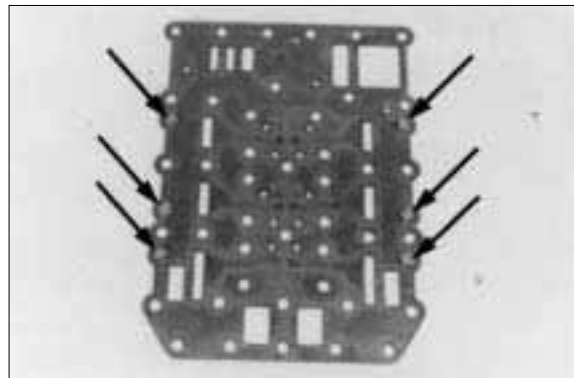

73073CV029

(14) Mount intermediate plate, with the screens showing upward.

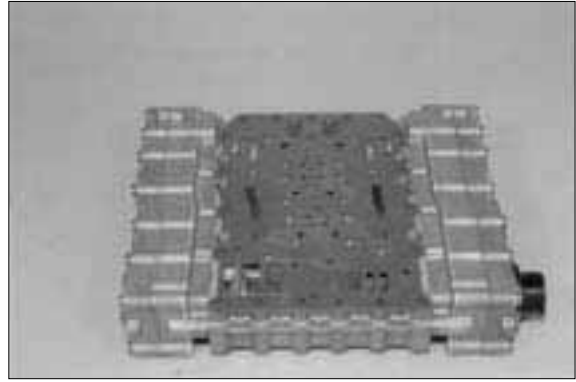

73073CV030

(15) Mount gasket II.

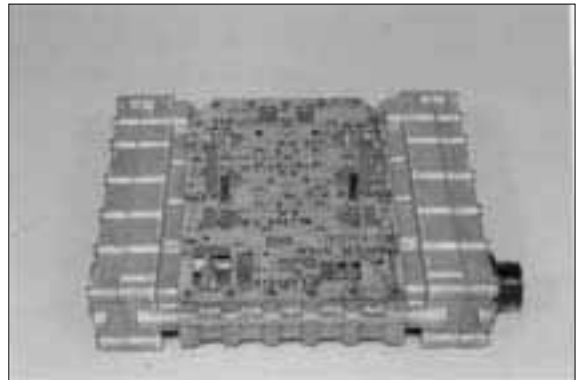

73073CV031

(16) Mount duct plate and fasten it uniformly by means of socket head screws.

· Torque limit : 0.97kgf · m(7.0lbf · ft)

Box spanner 5873 042 002

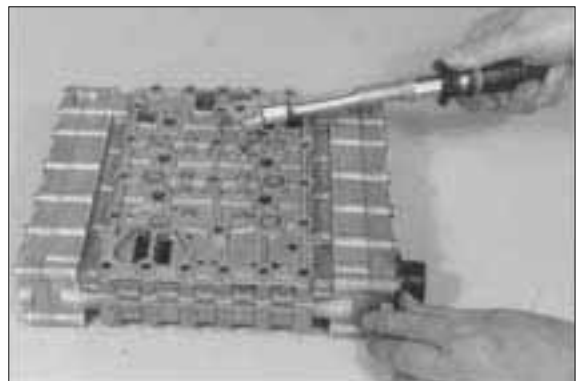

73073CV032

(17) Equip screw plug(8EA) with new O-rings and install them.

· Torque limit : 0.56kgf · m(4.06lbf · ft)

※ The installation of the hydraulic control unit is described, starting from page 3-137.

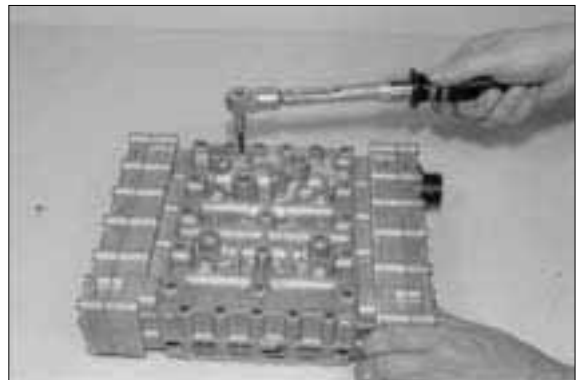

73073CV033

2. POWERSHIFT TRANSMISSION

Fasten transmission of the assembly car.

Assembly car 5870 350 000

Strips 5870 350 063

Support 5870 350 090



75773TM050

1) DISASSEMBLY

(1) Separate hydraulic control unit and duct plate from gearbox housing

- ① Loosen two socket head screws and install adjusting screws.

Now, loosen remaining socket head screws and separate valve housing from duct plate.

Adjusting screws(M6) 5870 204 063

Box spanner 5873 042 002



75773TM051

- ② Remove both gaskets and intermediate plate.

Loosen socket head screws as well as hexagon nuts and separate duct plate from gearbox housing.

Now, remove gasket.

Box spanner 5873 042 004



75773TM052

- ③ Pull converter safety valve out of the housing bore.



75773TM053

(2) Converter

- ① Loosen hexagon head screws and separate diaphragm from the converter.

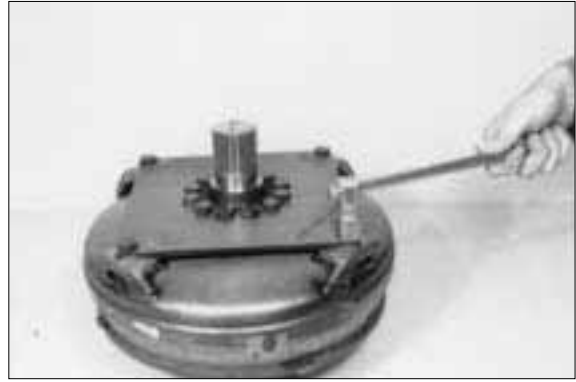

75773TM060

- ② Loosen hexagon head screws and separate drive shaft from the diaphragm.



75773TM061

- ③ Remove inductive transmitter(Engine).



75773TM062

- ④ Loosen hexagon head screws and remove converter bell.



75773TM063

(3) Hydraulic pump

- ① Loosen socket head screws.



75773TM064

- ② Apply separating device on the gear teeth runout of the stator shaft and pull pump(Compl.) by means of two leg puller carefully out of the housing bores.

Separating device 5870 300 024

Two leg puller 5870 970 004



75773TM065

- ③ Separate hydraulic pump from stator shaft.
Separate control disk from pump.

- ※ If traces due to running in should be encountered in the pump housing or on the control disk, the complete pump has to be renewed.

Now, lay on control disk again and fix it by means of grooved pins(2EA).



75773TM066

- ④ Loosen socket head screws as well as two hexagon head screws and remove oil feed housing.
Now, remove gasket.

Box spanner 5873 024 004



75773TM067

(4) Converter back pressure valve

- ① Preload compression spring and remove lock plate.
Remove released components.

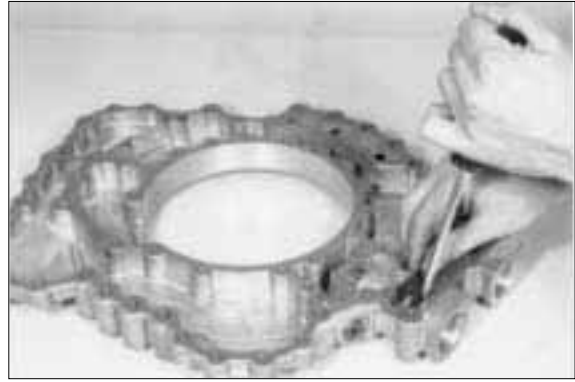

75773TM068

- ② Loosen hexagon head screws.
Remove cover and gasket.



75773TM069

(5) Remove output, input and clutches

- ① Remove lock plate, loosen hexagon head screws and pry converter side output flange off the shaft.
Now, pry shaft seal out of the housing bore.
Tilt transmission 180° and remove rear side output flange accordingly.
Pry bar 5870 345 065

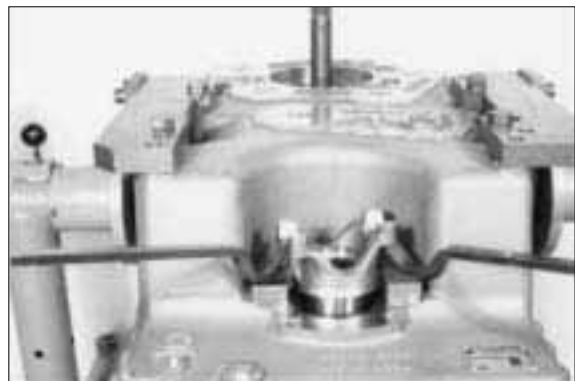

75773TM075

- ② Remove speed sensor as well as both inductive transmitters (Arrows).

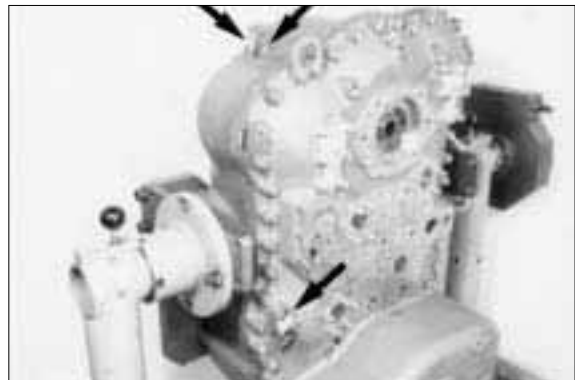

75773TM076

- ③ Loosen hexagon nuts and remove both covers(Arrows).
Loosen screw connection(Housing/
Housing cover).



75773TM077

- ④ Drive both cylindrical pins out(Arrows).



75773TM078

- ※ The following figures show the common removal of all clutches.
The removal of single clutches without use of the special tool(Handle 5870 260 010) is due to the installation conditions extremely difficult.

Besides there is the danger of injuries.

- ⑤ Locate all clutches by means of handles in the housing cover.
Install eye bolts and hang in the lifting device.

Handle(6 pieces needed)	5870 260 010
Eye bolt(M20, 2EA)	0636 804 003
Eye bolt(M16, 1EA)	0636 804 001
Puller device	5870 000 017
Lifting chain	5870 281 047



75773TM080

- ⑥ Separate housing cover along with clutches from the gearbox housing, using lifting device.



75773TM081

- ⑦ Fasten housing cover on the assembly car.

Assembly car 5870 350 000
Clamping bracket 5870 350 089



75773TM082

- ⑧ Loosen socket head screws and remove output shaft as well as the two oil collecting plate.



75773TM083

- ⑨ Pull off tapered roller bearing.
Remove opposite tapered roller bearing accordingly.

Grab sleeve 5873 002 038
Basic set 5873 002 001



75773TM084

⑩ Tilt housing cover 180°.

Illustration on the right shows the arrangement of the single clutches and the input in the housing cover.

AN Input
KV Clutch-Forward
KR Clutch-Reverse
K1 Clutch-1st speed
K2 Clutch-2nd speed
K3 Clutch-3rd speed
K4 Clutch-4th speed

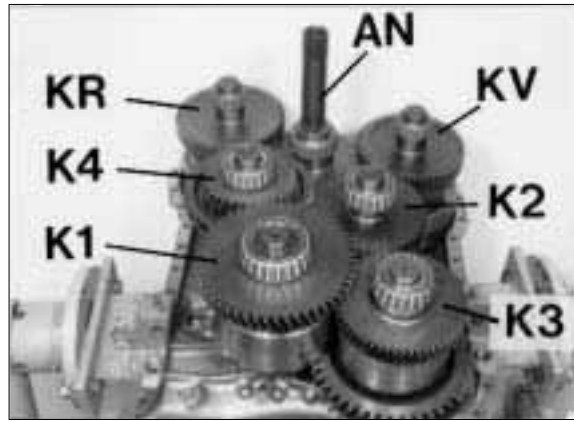

75773TM085

⑪ .Remove handles(See figure).

Handles 5870 260 010



75773TM086

⑫ Lift clutch K4 a bit by means of pry bars and remove clutch K1.

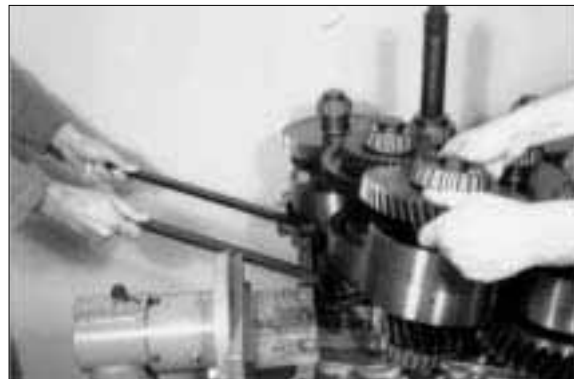

75773TM087

⑬ Remove clutch K2.



75773TM088

⑭ Remove clutch K3.



75773TM089

⑮ Lift clutch KV and KR by means of pry bars and remove clutch K4.

Pry bar 5870 345 065



75773TM090

□ Lift clutch KV and clutch KR as well as input together out of the housing cover. Remove bearing outer races out of the housing bores.

※ If contrary to the recommendation the tapered roller bearings of the clutches as well as of the input and output will not be renewed, the allocation (Bearing inner races to bearing outer races) must at least be maintained.

Mark bearing inner race and bearing outer race accordingly to each other.



75773TM091

□ Tilt housing cover 90°.

Squeeze circlip out and separate pump shaft from housing cover.



75773TM092

- Squeeze rectangular ring out(Arrow) and press ball bearing from the shaft.



75773TM093

(6) Disassemble clutch KV and KR

※ The following figures show the disassembly of clutch KV.

The disassembly of clutch KR is similar.

- ① Squeeze rectangular ring out(Arrow).



75773TM095

- ② Pull tapered roller bearing from the shaft.
Remove opposite tapered roller bearing accordingly.

Grab sleeve 5873 001 057

Grab sleeve 5873 001 059

Basic set 5873 001 000



75773TM096

- ③ Squeeze circlip out.



75773TM097

- ④ Separate plate carrier from the shaft.
Three leg puller 5870 971 003



75773TM098

- ⑤ Squeeze snap ring out and remove plate pack.



75773TM099

- ⑥ Preload compression spring, squeeze snap ring out and remove components.
Assembly aid 5870 345 088



75773TM100

- ⑦ Lift piston by means of compressed air out of the cylinder bore and remove it.



75773TM101

- ⑧ Remove both O-rings(Arrows).

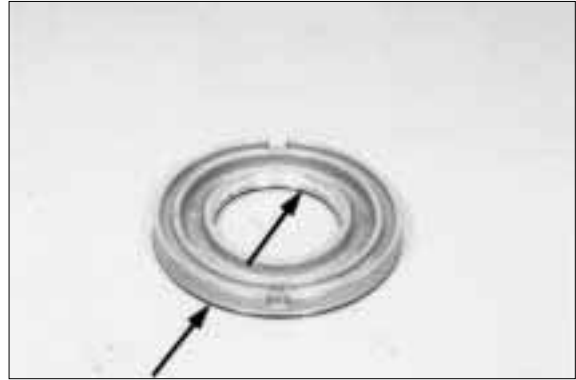

75773TM102

- ⑨ Lift idler gear a bit by means of pry bare.

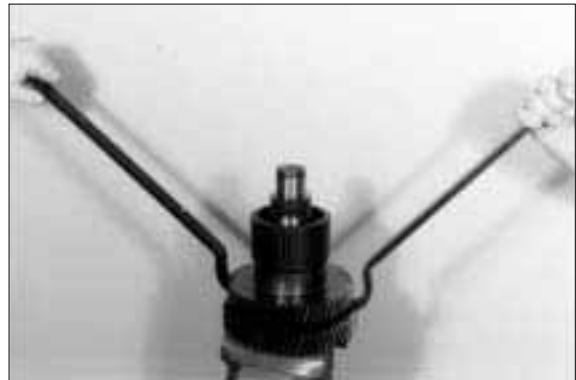

75773TM103

- ⑩ Apply puller and separate idler gear from the clutch shaft.

Pry bar

5870 345 065

Puller

5870 971 003



75773TM104

- ⑪ Squeeze circlip out and remove ball bearing.

- ※ The disassembly of clutch KR has to be carried out accordingly.



75773TM105

(7) Disassemble clutch K1, K2 and K3

※ The following figures show the disassembly of clutch K3.

The disassembly of the clutches K1 and K2 is similar.

① Squeeze rectangular ring out.

Pull tapered roller bearing from the shaft.
Remove the opposite tapered roller bearing accordingly.

Grab sleeve(Bearing 33800) 5873 001 059

Grab sleeve(Bearing 39500) 5873 002 038

Basic set 5873 001 000

Basic set 5873 002 001



75773TM110

② Remove running disk, axial needle cage and axial washer.



75773TM111

③ Remove idler gear.



75773TM112

- ④ Remove both needle bearings as well as the axial bearing(Complete).



75773TM113

- ⑤ Squeeze snap ring out and remove plate pack.



75773TM114

- ⑥ Preload cup-spring pack and squeeze snap ring out.
Remove released components.
Assembly aid 5870 345 088



75773TM115

- ⑦ Squeeze circlip into the groove of the plate carrier.
Apply puller on the circlip and pull plate carrier from the clutch shaft.
Puller 5870 970 004
Circlip 0630 502 053



75773TM116

(8) Disassemble clutch K4

- ① Squeeze rectangular ring out(Arrow).



75773TM120

- ② Pull tapered roller bearing from the shaft.
Remove opposite tapered roller bearing accordingly.

Grab sleeve 5873 001 057

Grab sleeve 5873 001 059

Basic set 5873 001 000



75773TM121

- ③ Squeeze circlip out and separate plate carrier from the shaft.

Three leg puller 5870 971 003



75773TM122

- ④ Squeeze snap ring out and remove plate pack.



75773TM123

- ⑤ Preload cup-spring pack and squeeze snap ring out.
Remove released components.
Remove piston.
Assembly aid 5870 345 008



75773TM124

- ⑥ Lift piston by means of compressed air out of the cylinder bore and remove it.



75773TM125

- ⑦ Take off the idler gear and remove release components.
※ The separation of shaft and gear is not possible(Shrink fit).



75773TM126

(9) Disassemble drive shaft

- ① Squeeze rectangular ring out.
Pull off tapered roller bearing.
Remove opposite tapered roller bearing accordingly.
Grab sleeve 5873 002 045
Basic set 5873 002 001
Basic set 5873 002 006



75773TM130

- ② If necessary, press turbine shaft out of the drive shaft.
※ The turbine shaft is axially fixed with a snap ring which will be destroyed at the pressing out.

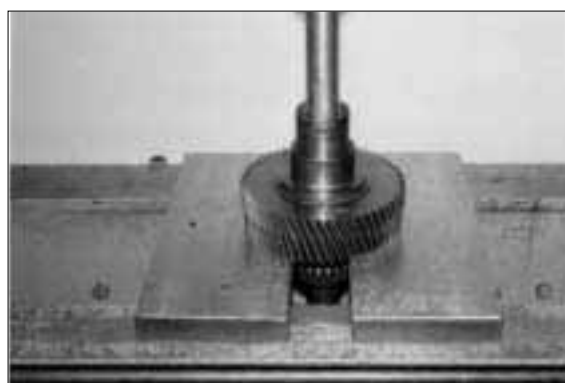

75773TM131

2) REASSEMBLY

(1) Install oil tubes

※ To ensure the correct installation of the oil tubes, the use of the indicated special tool is imperative.

- ① Insert suction pipe(1), pressure pipes(2) and pressure pipelubrication(3) into the housing bores.

Fasten suction and pressure pipes by means of socket head screws.

· Torque limit : 2.3kgf · m(17.0lbf · ft)



75773TM140

- ② Tilt housing 180° .

Roll suction as well as pressure pipes(Arrows) into the housing bores, using special tool.

The pipe end must be maximally plane with the housing face.

If necessary, equalize projection of pipe.

Rolling tool 5870 600 003

Rolling tool 5870 600 005

Rolling tool 5870 600 007

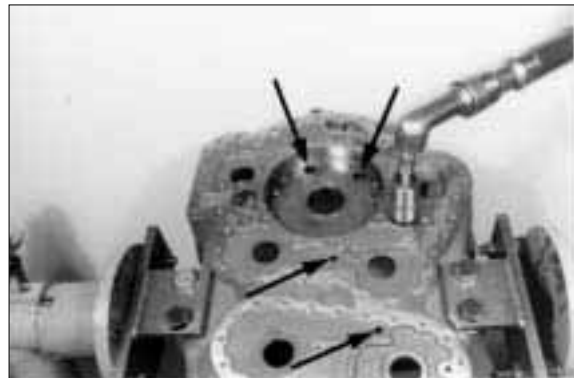

75773TM141

- ③ Insert O-rings(2EA/pipe) into the annular grooves of the two oil tubes and oil them.



75773TM142

(2) Reassemble clutch KV and KR

- ※ The following figure show the reassembly of the clutch KV. The reassembly of the clutch KR has to be carried out accordingly.

Preassemble plate carrier

- ① Check function of the purge valve.
 - ※ Ball must not stick, if necessary, clean with compressed air.

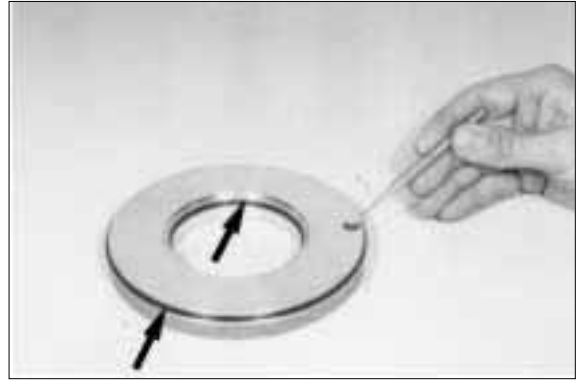

75773TM150

- ② Insert both O-ring(Arrows) scrollfree into the grooves of the piston and oil. Introduce piston until contact is obtained.
 - ※ Pay attention to the installation position, see figure.



75773TM151

- ③ Install disk, compression spring and guide ring.



75773TM152

- ④ Preload compression spring and fix it by means of snap ring.
Assembly aid 5870 345 088



75773TM153

Plate pack KV, KR

- ※ The plate arrangement respectively stacking of clutch KV and KR is identical.
- ⑤ The following draft shows the installation position of the components.

- 1 Plate carrier
- 2 Piston
- 3 Outer plate-one sided coated(1 piece)
- 4 Inner plates(10 pieces)
- 5 Outer plates-coated on both sides (10 pieces)
- 6 Snap ring(Optional s= 2.1~4.2mm)
- 7 End shim

Effective number of friction surfaces = 20

- ※ Install outer plate 3 with the uncoated side facing the piston.
- Install on the end-shim side two outer and inner plates each.

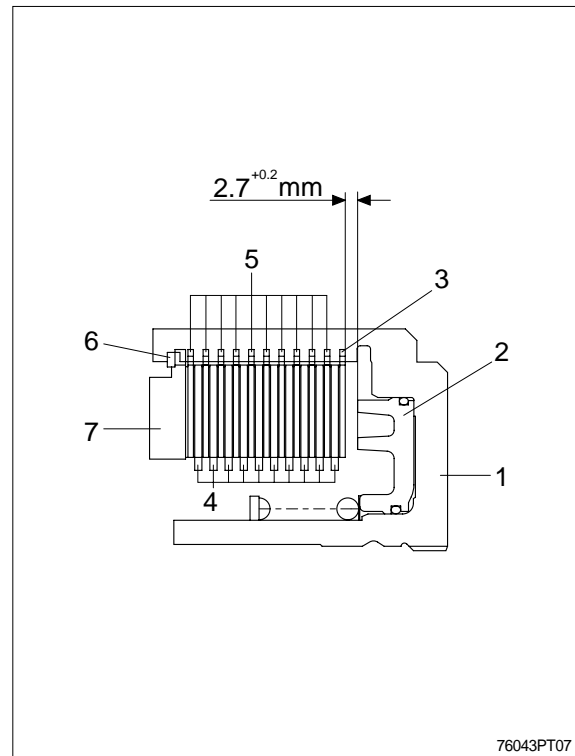

76043PT07

Adjust plate clearance : $2.7+0.2$ mm

- ※ For the adjustment of the plate clearance are snap rings of different thickness available.
- To ensure a faultless measuring result, install plates for the moment without oil.
- ⑥ Introduce plate pack according to the upper draft.



75773TM155

- ⑦ Lay on the end shim and squeeze the snap ring in(e.g. s=2.55mm)



75773TM156

- ⑧ Press on end shim with about 100N (10kg), apply dial indicator and set it at zero.



75773TM157

- ⑨ Now, push the end shim by means of screw driver against snap ring until contact is obtained(Upward) and read plate clearance on the dial indicator.

※ In case of a deviation from the required plate clearance, correct with corresponding snap ring(s=2.1~4.2mm). After the adjustment of the plate clearance has been carried out, remove the plate pack, oil plates and install it again.

※ Use oil SAE 15W-40(API CH-4).

Magnetic stand 5870 200 055

Dial indicator 5870 200 057

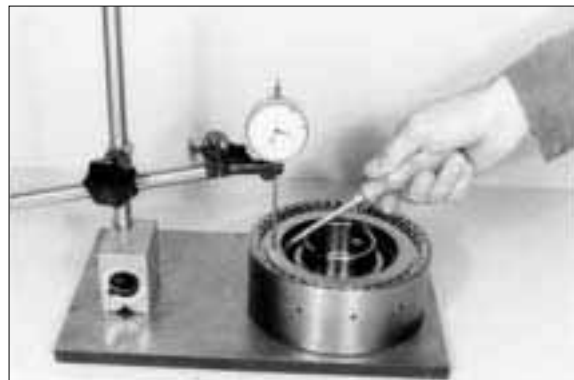

75773TM158

- ⑩ Introduce idler gear until all inner plates are accommodated.

※ This step makes the later assembly of the idler gear easier.

Now, remove the idler gear again.



75773TM159

- ⑪ Mount stud(Arrow).
Wet screw-in thread with loctite(Type No.241).
• Torque limit(M10) : 1.7kgf · m(12.5lbf · ft)



75773TM160

- ⑫ Insert ball bearing until contact is obtained and fix by means of circlip.



75773TM161

- ⑬ Assemble needle bearing.



75773TM162

- ⑭ Press idler gear against shoulder.
※ Support it on the bearing inner race.



75773TM163

- ⑮ Heat inner diameter of plate carrier (About 120°C).

Hot air blower 220V 5870 221 500

Hot air blower 110V 5870 221 501



75773TM164

- Assemble preassembled plate carrier until contact is obtained.



75773TM165

- Locate plate carrier axially by means of circlip.



75773TM166

- Check function of clutch by means of compressed air.
※ At correctly installed components, the closing resp. opening of the clutch is clear audible.



75773TM167

- Press tapered roller bearing against shoulder.
Install opposite tapered roller bearing accordingly.



75773TM168

- Squeeze rectangular rings in(Arrow) and let them snap in.



75773TM169

(3) Reassemble clutch K1, K2 and K3

- ※ The following figures show the reassembly of clutch K3.

The reassembly of the clutches K1 and K2 has to be carried out accordingly.

- ① Install stud(Arrow).

- ※ Wet screw in thread with loctite(Type No. 241).

- Torque limit(M10) : 1.7kgf · m(12.5lbf · ft)



75773TM175

- ② Heat inner diameter of plate carrier.



75773TM176

- ③ Assemble plate carrier until contact is obtained.

Hot air blower 220V 5870 221 500

Hot air blower 110V 5870 221 501



75773TM177

- ④ .Check function of the purge valve

※ Ball must not stick, if necessary clean with compressed air.

Insert both O-rings(Arrows) scrollfree into the grooves of the piston and oil.

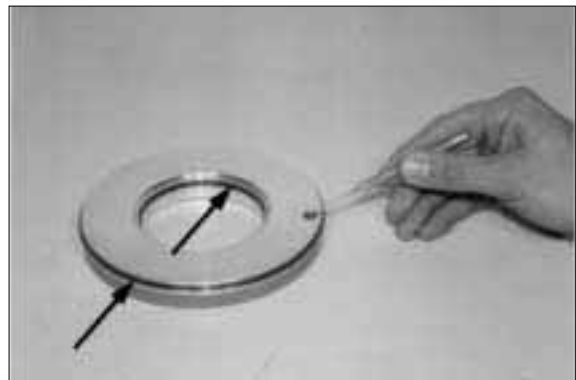

75773TM178

- ⑤ Introduce piston until contact is obtained.

※ Pay attention to the installation position, see figure.



75773TM179

- ⑥ Lay on cup spring pack and guide ring.

※ Pay attention to the stacking of the cup springs, see the next draft.



75773TM180

- ⑦ Preload cup spring pack and fix it by means of snap ring.
 Assembly aid 5870 345 088



75773TM181

- ※ The plate arrangement of clutch K1 is identical with clutch K2 and K3.
 In this connection see the following drafts.

Plate pack K1

- 1 Plate carrier
 - 2 Piston
 - 3 Outer plate-one side coated(1 piece)
 - 4 Inner plates(9 pieces)
 - 5 Outer plates-on both sides coated (9 pieces)
 - 6 Snap ring(Optional s=2.1~4.2mm)
 - 7 End shim
- Effective number of friction surfaces = 18

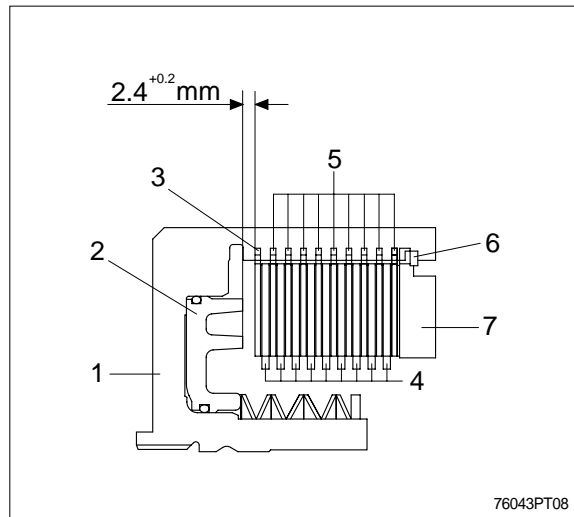

76043PT08

- ※ Install outer plate 3 with the uncoated side facing the piston.

Plate pack K2 and K3

- 1 Plate carrier
 - 2 Piston
 - 3 Outer plate-one side coated(1 piece)
 - 4 Inner plates(7 pieces)
 - 5 Outer plates-on both side coated (7 pieces)
 - 6 Snap ring(Optional s= 2.1~4.2mm)
 - 7 End shim
- Effective number of friction surfaces = 14

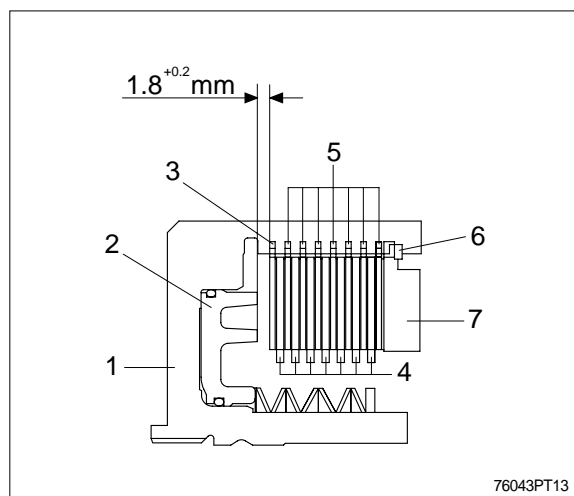

76043PT13

- ※ Install outer plate 3 with the uncoated side facing the piston.
 Install on the end-shim two outer and inner plates each.

Adjust plate clearance

Plate clearance clutch K1 $2.4^{+0.2}\text{mm}$

Plate clearance clutch K2 and K3
 $1.8^{+0.2}\text{mm}$

※ For the adjustment of the plate clearance are snap rings with different thickness available.

To ensure a faultless measuring result, install the plates for the moment without oil.

Introduce plate pack according to drafts / page 3-107.

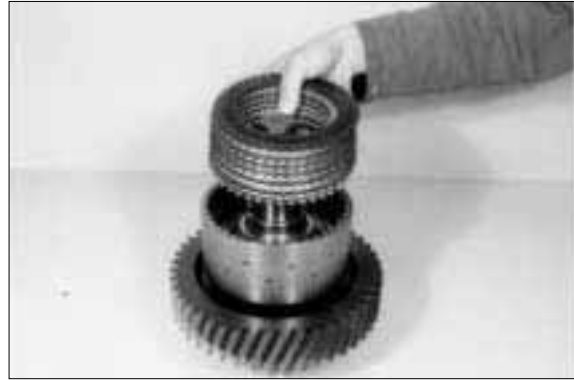

75773TM185

⑧ Lay on the end shim and squeeze circlip in (e.g. $s=3.1\text{mm}$).



75773TM186

⑨ Press on the end shim with about 100N (10kg), apply dial indicator and set it at zero.



75773TM187

⑩ Now, push the end shim by means of screw driver against snap ring until contacts is obtained(Upward) and read plate clearance on the dial indicator.

※ In case of a deviation from the required plate clearance, correct with corresponding snap ring(s=2.1~4.2mm). After the adjustment of the plate clearance has been carried out, remove the plate pack, oil plates and install it again.

Use oil SAE 15W-40(API CH-4).

Magnetic stand 5870 200 055

Dial indicator 5870 200 057

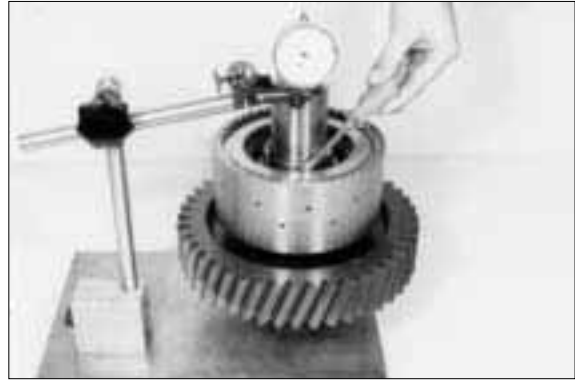

75773TM188

⑪ Assemble running disk 1(55×78×5), axial needle cage 2 and axial washer 3 (55×78×1).

Install running disk 1, with the chamber facing the axial needle cage.



75773TM189

⑫ Assemble both needle bearings.



75773TM190

- ⑬ Introduce idler gear until all inner plates are accommodated.



75773TM191

- ⑭ Assemble axial washer 3(55×78×1), axial needle cage 2 and running disk 1 (55×78×5).
- ※ Install running disk 1, with the chamfer facing the axle needle cage.
 - ※ Only if the running disk in overlapping with the shaft collar is ensured that all inner plates are accommodated.



75773TM192

- ⑮ Press tapered roller bearing against shoulder.
- Press opposite tapered roller bearing against shoulder.



75773TM193

- Check function of the clutch by means of compressed air.
- ※ At correctly installed components, the closing respectively opening of the clutch is clearly audible.



75773TM194

- Squeeze rectangular ring in(Arrow) and let it snap in.
Install opposite rectangular ring accordingly.



75773TM195

(4) Reassemble clutch K4

- ① Undercool shaft(About -80°C), heat gear (About $+120^{\circ}\text{C}$) and assemble it until contact is obtained.



75773TM200

- ② Fix gear axially by means of circlip.
Set of external pliers 5870 900 015



75773TM201

- ③ Install stud(Arrow).
※ Wet screw-in thread with loctite(Type No. 241).
· Torque limit(M10) : $1.7\text{kgf} \cdot \text{m}$ ($12.5\text{lb} \cdot \text{ft}$)



75773TM202

- ④ Check function of the purge valve.
※ Ball must not stick, if necessary clean with compressed air.
Insert both O-ring(Arrow) scrollfree into the grooves of the piston and oil them.

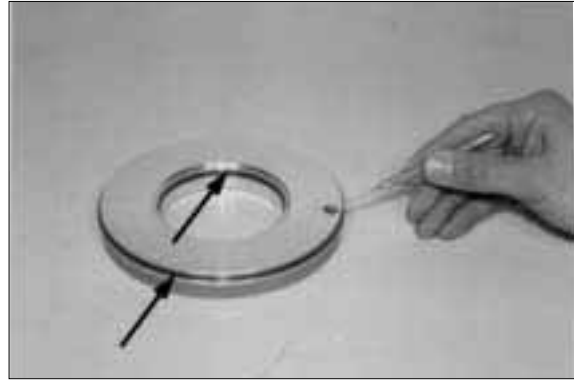

75773TM203

- ⑤ Introduce piston until contact is obtained.
※ Pay attention to the installation position, see figure.



75773TM204

- ⑥ Install cup-spring pack and guide ring.
※ Pay attention to the stacking of the cup springs, see the next draft.



75773TM205

- ⑦ Preload cup-spring pack and fix it by means of snap ring.
Assembly aid 5870 345 088



75773TM206

Plate pack K4

※ The following draft shows the installation position of the components.

- 1 Plate carrier
- 2 Piston
- 3 Outer plate-one side coated(1 piece)
- 4 Inner plates(5 pieces)
- 5 Outer plates-coated on both sides (5 pieces)
- 6 Snap ring(Optional s= 2.1~4.2mm)
- 7 End shim

Effective number of friction surfaces = 10

※ Install outer plate 3 with the uncoated side facing the piston.

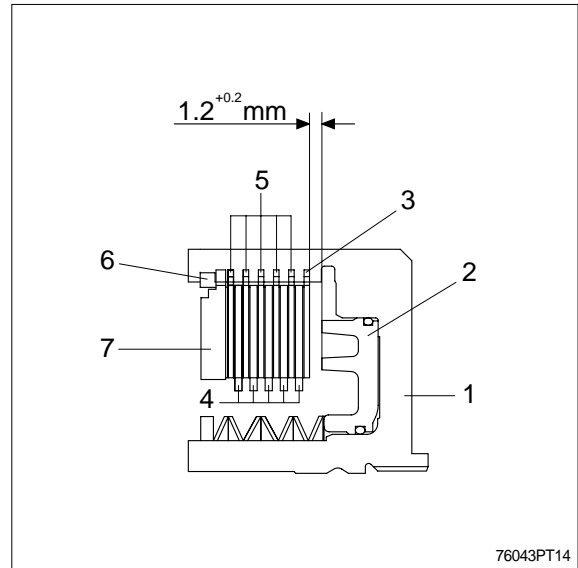

Adjust plate clearance = $1.2^{+0.2}$ mm

※ For the adjustment of the plate clearance are snap rings of different thickness available.

To ensure a faultless measuring result, install plates for the moment without oil.

⑧ Introduce plate pack according to the draft.



⑨ Lay on end shim and squeeze snap ring in(e.g. s= 3.4mm).



- ⑩ Press on the end shim with about 100N (10kg), apply dial indicator and set it at zero.



75773TM212

- ⑪ Now, push the end shim by means of screw driver against snap ring until contacts is obtained(Upward) and read plate clearance on the dial indicator.

※ In case of a deviation from the required plate clearance, correct with corresponding snap ring(s=2.1~4.2mm). After the adjustment of the plate clearance has been carried out, remove the plate pack, oil plates and install it again.

※ Use oil SAE 15W-40(API CH-4).

Magnetic stand 5870 200 055

Dial indicator 5870 200 057

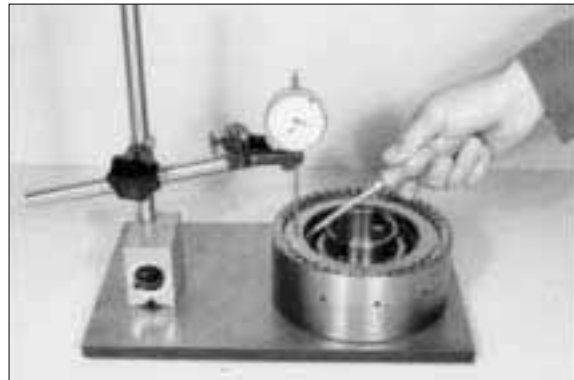

75773TM213

- ⑫ Introduce idler gear until all inner plates are accommodated.

※ This step makes the later assembling of the idler gear easier.

Now, remove idler gear again.



75773TM214

- ⑬ Assemble both axial washers as well as needle case.
※ Upper and lower axial washer have the same thickness(55 × 78 × 1).



75773TM215

- ⑭ Assemble both needle bearings.



75773TM216

- ⑮ Assemble idler gear.



75773TM217

- Assemble axial washer 3(55 × 78 × 1), needle cage 2 and running disk 1(55 × 78 × 5).
※ Install running disk 1, with the chamfer facing the needle cage.



75773TM218

- Heat inner diameter of the plate carrier (About 120°C).
Assemble preassembled plate carrier until all inner plates are accommodated.
- ※ Use safety gloves.



75773TM219

- Fix plate carrier axially by means of circlip.
Set of external pliers 5870 900 015



75773TM220

- Check function of the clutch by means of compressed air.
- ※ At correctly installed components, the closing respectively opening of the clutch is clearly audible.



75773TM221

- Press tapered roller bearing against shoulder.
Install opposite tapered roller bearing.



75773TM222

Squeeze rectangular ring in(Arrow) and let it snap in.
Install opposite rectangular ring.



75773TM223

(5) Preassemble drive shaft

- ① Undercool the drive shaft(About -80°C), heat the gear(About $+120^{\circ}\text{C}$) and assemble it until contact is obtained.



75773TM225

- ② Fix gear axially by means of circlip.



75773TM226

- ③ Squeeze snap ring into groove of the turbine shaft.



75773TM227

- ④ Introduce turbine shaft until the snap ring snaps into the groove of the drive shaft turbine shaft is axially fixed.



75773TM228

- ⑤ Press tapered roller bearing against shoulder.
Now, squeeze rectangular ring into the groove of the drive shaft and let it snap in.
Install opposite tapered roller bearing.



75773TM229

(6) Preassemble and install output

- ① Lay on screening plate



75773TM230

- ② Heat tapered roller bearing and assemble it until contact is obtained.
Install opposite tapered roller bearing accordingly.



75773TM231

③ Insert all bearing outer races into the bearing bores of the housing.
Install O-ring(Arrows).

※ At the use of already run bearings, pay attention to the allocation of the bearing outer races, see also note/page 3-95.

- AN Input
- KV Clutch-Forward
- KR Clutch-Reverse
- K1 Clutch-1st speed
- K2 Clutch-2nd speed
- K3 Clutch-3rd speed
- K4 Clutch-4th speed
- AB Output

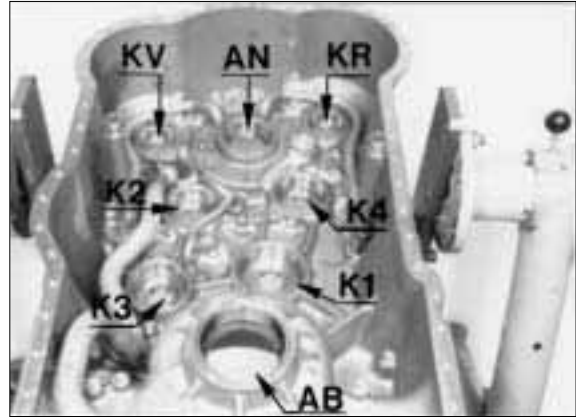

75773TM232

④ Lay on screening plate.



75773TM233

⑤ Insert preassembled output shaft.
Fix screening plates by means of socket head screws.

- Torque limit(M8/8.8) : 2.3kgf · m
(17.0lbf · ft)



75773TM234

(7) Install preassembled drive shaft and clutches

① Insert all bearing outer races into the bearing bores of the housing cover.

※ At the use of already run bearings, pay attention to the allocation of the bearing outer races, see also note/page 3-95.

- AN Input
- KV Clutch-Forward
- KR Clutch-Reverse
- K1 Clutch-1st speed
- K2 Clutch-2nd speed
- K3 Clutch-3rd speed
- K4 Clutch-4th speed
- AB Output

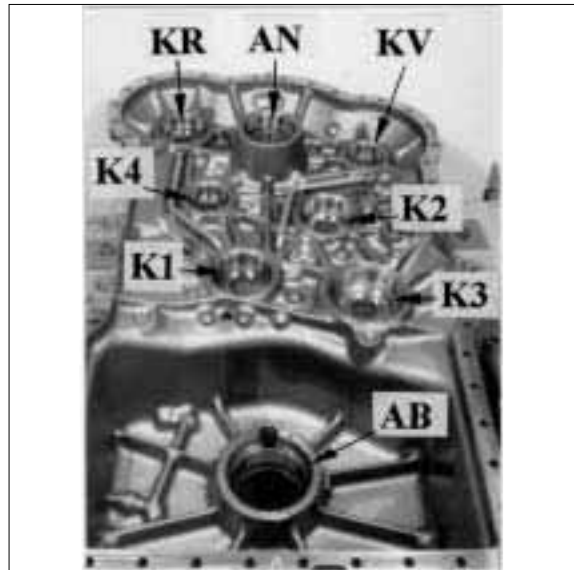

75773TM235

※ Prior to the installation of the clutches and the drive shaft, grease rectangular rings and align them centrally.

② Insert clutch KR, drive shaft and clutch KV together into the housing cover.



75773TM236

③ Lift drive gear and position clutch K4.



75773TM237

④ Install clutch K3.



75773TM238

⑤ Position clutch K2.



75773TM239

⑥ Lift clutch K4 and position clutch K1.



75773TM240

⑦ Illustration on the right shows the installation position of the single clutches in the housing cover. Grease rectangular rings (Arrows) and align them centrally.

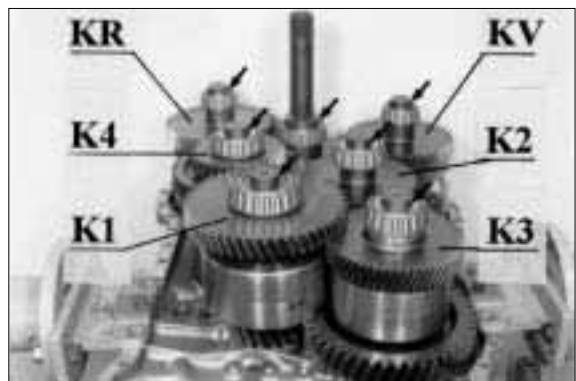

75773TM241

- ⑧ Fix all clutches by means of handles.
 Handle(6 pieces needed) 5870 260 010

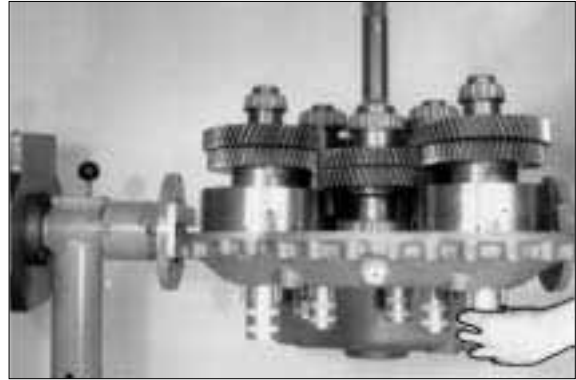

75773TM242

- ⑨ Tilt housing cover 180°.
 Install eye bolts(Arrows).
 Eye bolt(M20, 2EA) 0636 804 003
 Eye bolt(M16, 1EA) 0636 804 001
 Puller device 5870 000 017



75773TM243

- ⑩ Grease O-rings of the two oil tubes.
 Wet mounting face with sealing compound loctite(Type No.574).
 Position preassembled housing cover by means of lifting device carefully on the gearbox housing until contact is obtained.
 ※ Pay attention to the overlapping of the oil tubes with the bores in the housing cover.
 Lifting chain 5870 281 047



75773TM244

- ⑪ Remove handles again.

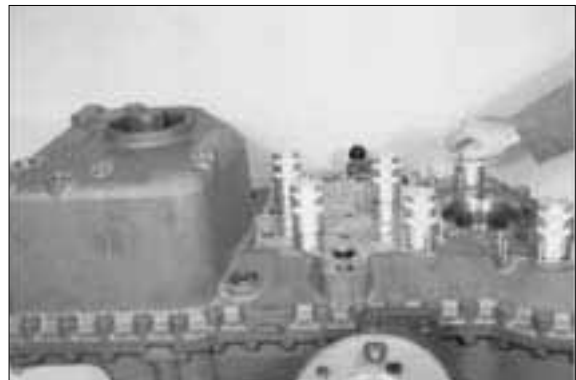

75773TM245

- ⑫ Install both cylindrical pins centrally to the housing face.



75773TM246

- ⑬ Fasten housing cover by means of hexagon head screws.

· Torque limit(M10/8.8) : 4.7kgf · m
(33.9lbf · ft)

- ※ Pay attention to position of the fixing plate, see Arrow.

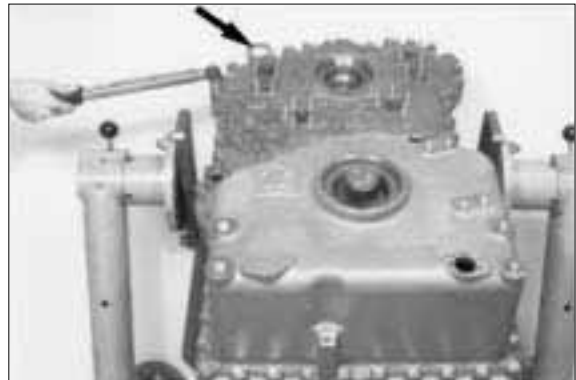

75773TM247

(8) Install pump shaft(Power take off)

- ① Install ball bearing.

Squeeze rectangular ring in(Arrow) and let it snap in.

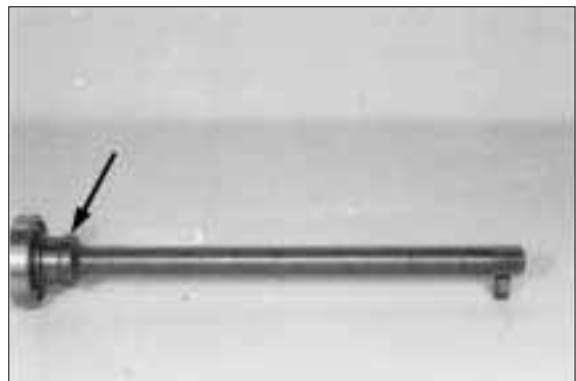

75773TM248

- ② Grease rectangular ring, align it centrally and introduce pump shaft until contact is obtained.



75773TM249

- ③ Fix pump shaft by means of circlip.

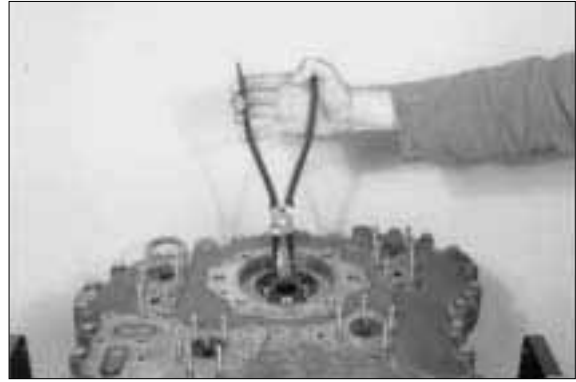

75773TM250

- ④ Insert O-ring(Arrow) into the annular groove of the oil feed covers.

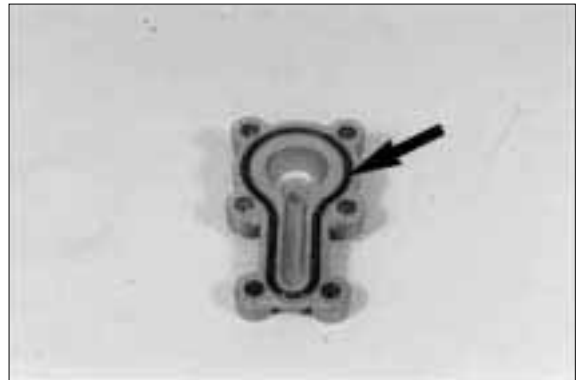

75773TM251

- ⑤ Fasten both covers(Arrows) by means of hexagon nuts(Use plain washers).
• Torque limit : 2.3kgf · m(17.0lbf · ft)



75773TM252

(9) Install output flanges

- ① Install shaft seal with the sealing lip facing the oil chamber.
※ At the use of the prescribed driver, the exact installation position is obtained.
Wet rubber coated outer diameter with spirit.
Grease sealing lip.
Driver 5870 048 213



75773TM255

- ② Assemble output flange.
Insert O-ring(Arrow) into the gap of drive flange and shaft.



75773TM256

- ③ Fasten output flange by means of disk and hexagon head screws.
· Torque limit(M10/8.8) : 4.7kgf · m
(33.9lbf · ft)

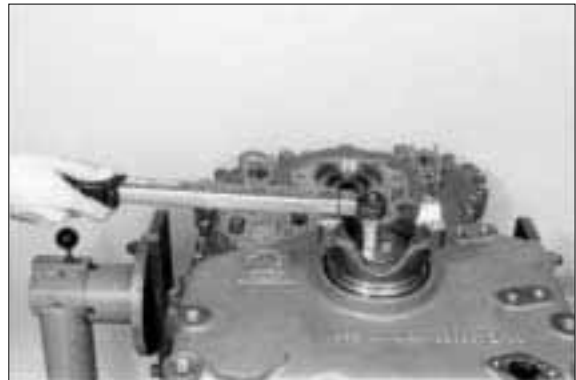

75773TM257

- ④ Fix hexagon head screws by means of lock plate.
Driver 5870 057 009
Handle 5870 260 002
Install converter side output flange accordingly.

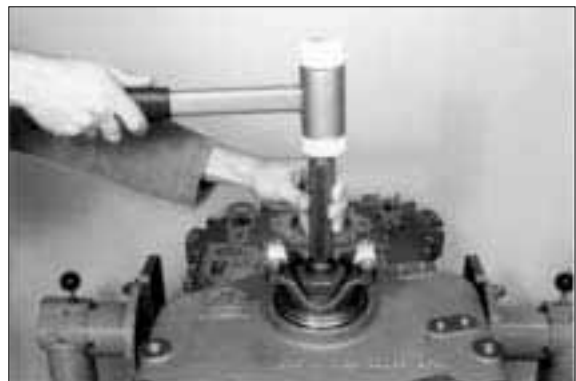

75773TM258

(10) Converter back pressure valve

- ① Illustration on the right shows the components of the converter back pressure valve.

- 1 Piston
- 2 Compression spring
- 3 Pressure plate
- 4 Lock plate

- ※ Install pressure plate with the spigot (∅ 6mm) facing the lock plate.

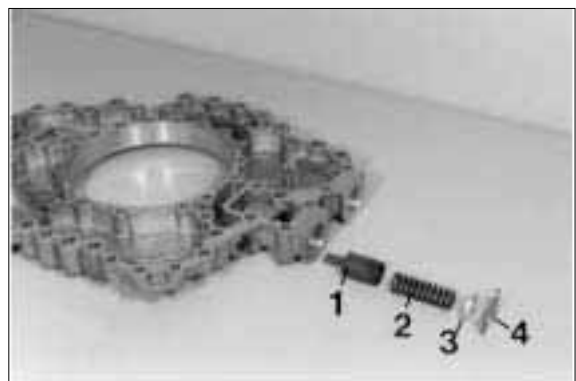

75773TM260

- ② Introduce components according to figure (10) ①, preload and fix by means of lock plate.

Equip plug(Arrow) with new O-ring and install it.

- Torque limit(M14 × 1.5) : 2.5kgf · m
(18.4bf · ft)

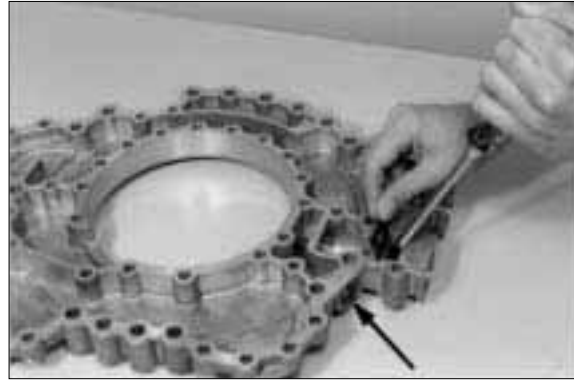

75773TM261

(11) Oil feed housing-Transmission pump

- ① Install two adjusting screws(Arrows) and lay on gasket.

Adjusting screws(M8) 5870 204 011

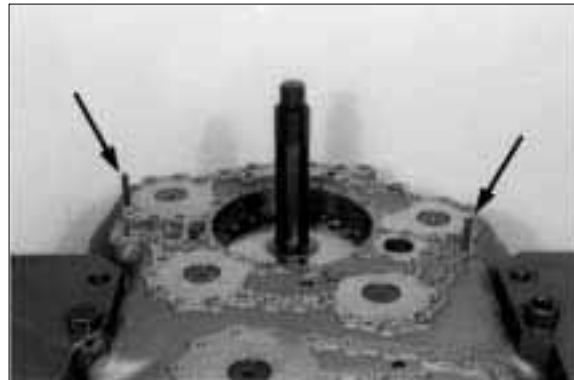

75773TM262

- ② Lay on oil feed housing and fix it provisionally by means of socket head screws.

- ※ Screw socket head screws only in until contact is obtained **do not tighten**.



75773TM263

- ③ Install two adjusting screws and introduce stator shaft until contact is obtained.

- ※ Pay attention to the overlapping of the bores.

Adjusting screws(M10) 5870 204 007

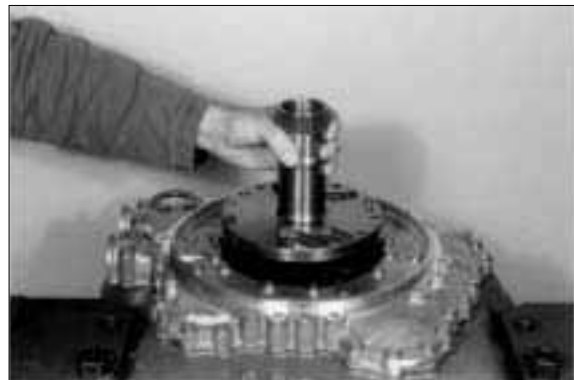

75773TM264

- ④ Insert O-ring(Arrow) into the annular groove and oil it.



75773TM265

- ⑤ Introduce transmission pump(Complete) and put it by means of socket head screws(For the moment without O-rings) evenly against shoulder.
Now, remove socket head screws again.



75773TM266

- ⑥ Equip socket head screws with new O-ring(Arrow).
※ Grease O-rings.

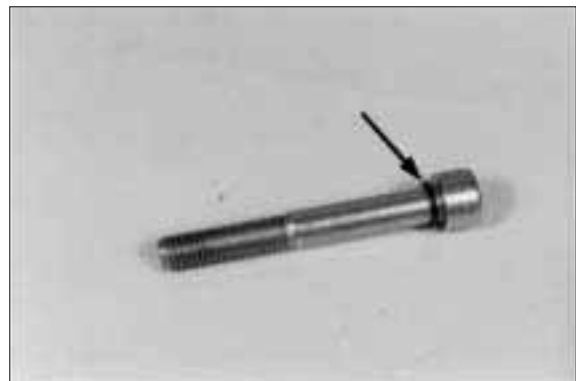

75773TM267

- ⑦ Fasten transmission pump by means of socket head screws.
· Torque limit : 4.7kgf · m(33.9lbf · ft)

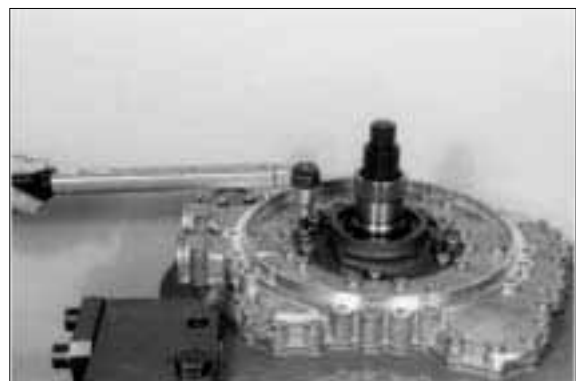

75773TM268

- ⑧ Fasten oil feed housing by means of socket head screws and hexagon head screws(2 pieces).

· Torque limit

- Socket head screw : 2.3kgf · m
(16.6bf · ft)

- Hexagon head screw : 4.7kgf · m
(33.9bf · ft)

- ※ Pay attention to the position of the fixing plate, see Arrow.

Box spanner(Torx, TX-40) 5873 042 004

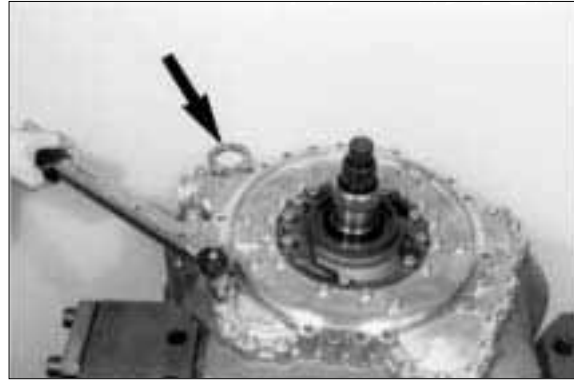

75773TM269

(12) Engine connection-Converter

- ① Fasten converter bell by means of hexagon head screws.

· Torque limit(M10/10.9) : 6.9kgf · m
(50.1bf · ft)



75773TM270

- ② Screw drive shaft and diaphragm together.

· Torque limit(M12/10.9) : 11.7kgf · m
(84.8bf · ft)

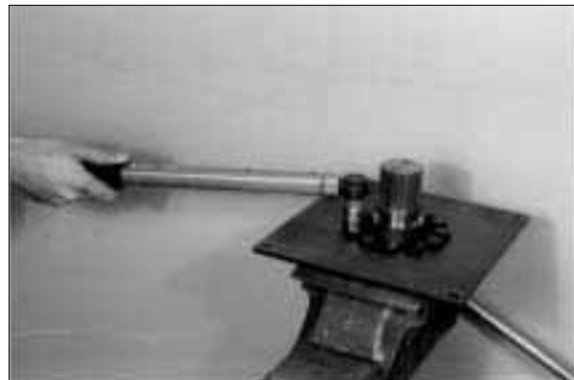

75773TM271

- ③ Fasten diaphragm by means of hexagon head screws on the converter.

· Torque limit(M12/10.9) : 11.7kgf · m
(84.8bf · ft)

- ※ Insert hexagon head screws with loctite (Type No.262).

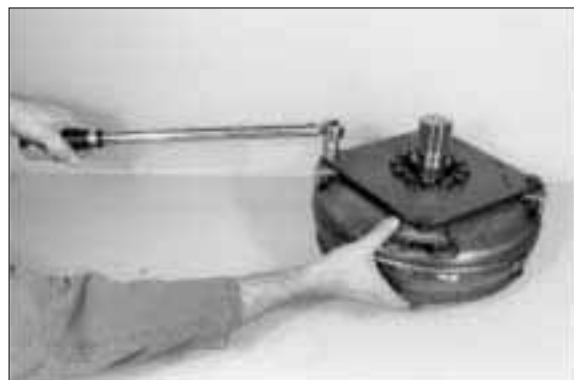

75773TM272

④ Introduce converter until contact is obtained.

※ Pulse disk of the converter must be positioned centrally to the bore of the inductive transmitter, see Arrow.

Only in this way will be ensured that the converter is perfectly introduced.



75773TM273

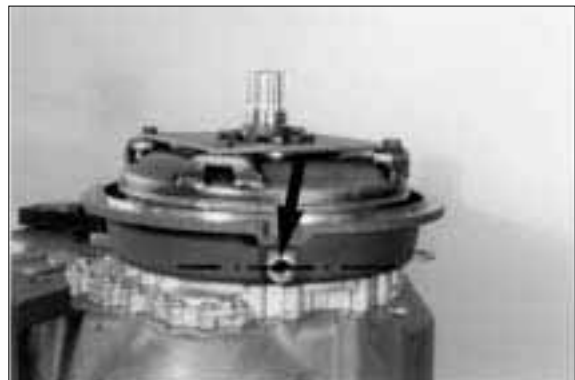

75773TM274

⑤ Insert ball bearing until contact is obtained and fix it by means of circlip.



75773TM275

⑥ Assemble housing cover.

Install drive flange, lay on disk and pull cover by means of hexagon head screws evenly against shoulder.

· Torque limit(M8/10.9) : 3.5kgf · m
(25.1bf · ft)

※ Pay attention to the radial installation position of the cover, see figure.



75773TM276

- ⑦ Fix hexagon head screws by means of lock plate.

Driver 5870 057 010

Handle 5870 260 002



75773TM277

- ⑧ Fasten cover by means of hexagon head screws and nuts on the converter bell.

- Torque limit(M10/838) : 4.7kgf · m
(33.9lbf · ft)

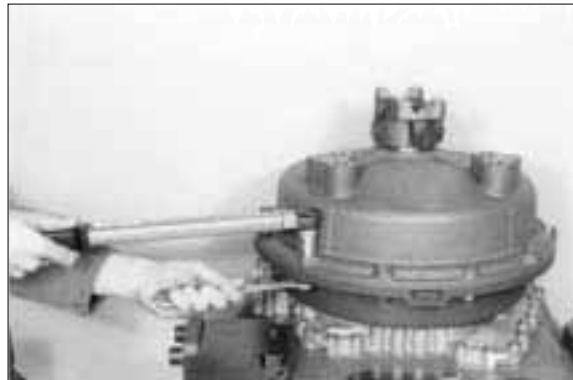

75773TM278

- ⑨ Mount gasket and fasten cover by means of hexagon head screws.

- Torque limit(M8/8.8) : 2.3kgf · m
(17.0lbf · ft)



75773TM279

(13) Converter safety valve

- ① Insert converter safety valve(Complete) into the housing hose.



75773TM280

(14) Mount duct plate and hydraulic control unit

Install components according to the

① following draft.

· Torque limit(M8) : 2.3kgf · m(17.0lbf · ft)

Pay attention to the installation position of

※ the different gaskets, see draft.

- 1 Gasket
- 2 Duct plate
- 3 Gasket
- 4 Intermediate plate
- 5 Gasket

Adjusting screws 5870 204 063

Box spanne 5873 042 004

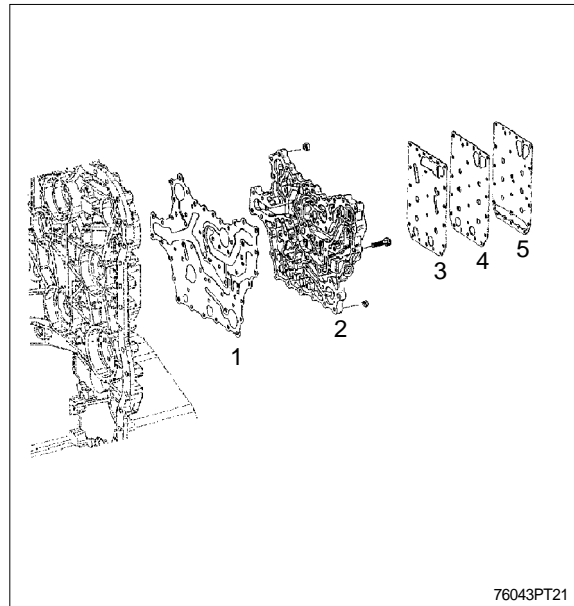

② Equip screw plug(Arrow) with new O-ring and install it.

· Torque limit(M16× 1.5) : 3.0kgf · m
(21.7lbf · ft)

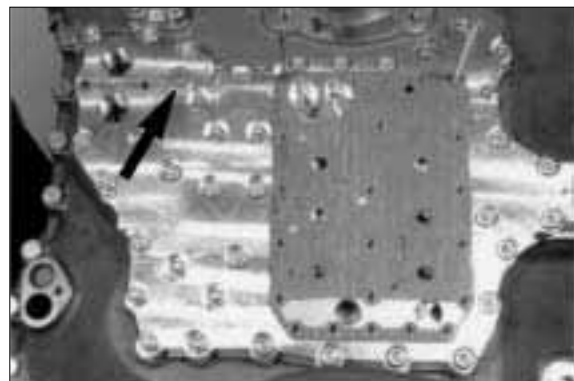

③ Fasten hydraulic control unit(HSG-94) by means of socket head screws.

· Torque limit(M6) : 0.97kgf · m(7.0lbf · ft)

Adjusting screws 5870 204 063

Box spanner(Torx Tx-27) 5873 042 002

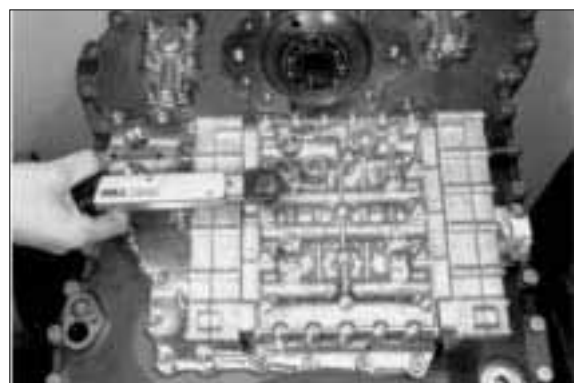

(15) Install plugs and oil level tube

① Equip both plugs(Arrows) with new O-rings and install them.

- Torque limit(M18 × 1.5) : 5.1kgf · m
(36.9lbf · ft)
- Torque limit(M26 × 1.5) : 8.2kgf · m
(59.0lbf · ft)

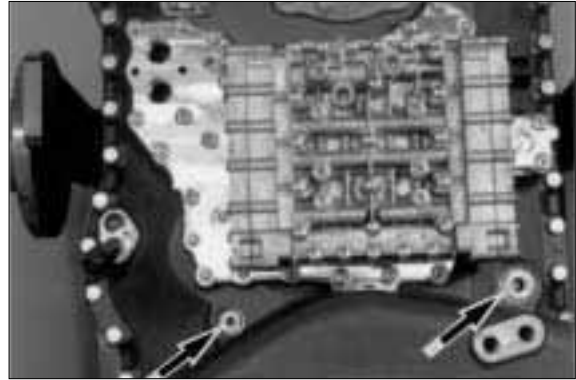

75773TM284

② Install oil level tube(Arrow).

※ Mount new gasket.

- Torque limit(M8/10.9) : 3.5kgf · m
(25.1lbf · ft)

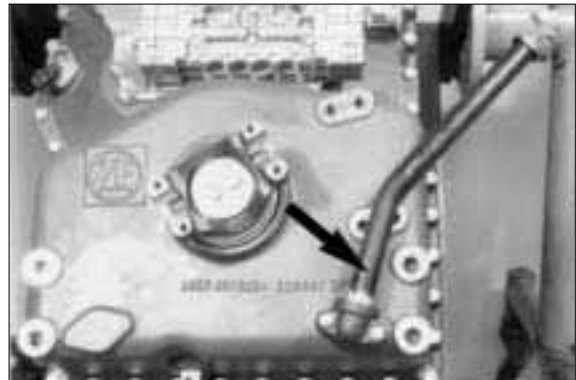

75773TM285

③ Install cover plate(Arrow 1).

※ Install new gasket.

- Torque limit(M8/8.8) : 2.3kgf · m
(17.0lbf · ft)

Equip screw plug(Arrow 2) with new O-ring and install it.

- Torque limit(M38 × 1.5) : 14.3kgf · m
(103lbf · ft)



75773TM286

(16) Speed sensor and inductive transmitters

- ① The figures show the installation position of the single inductive transmitters and the speed sensor.

- 34 Speed sensor
n-Output and speedometer
- 21 Inductive transmitter
n-Turbine
- 47 Inductive transmitter
n-Central gear train
- 48 Inductive transmitter
n-Engine

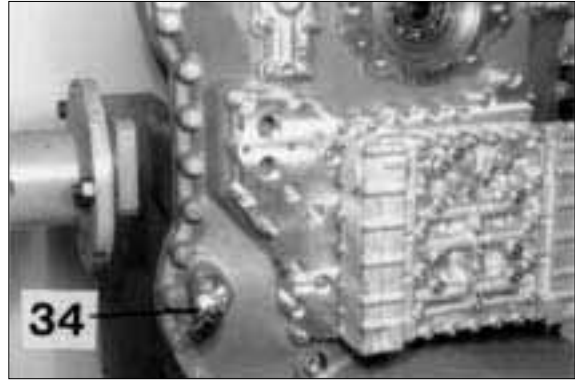

75773TM290

- ② Grease O-rings and install speed sensor as well as inductive transmitters.

- Torque limit : 2.3kgf · m(17.0lbf · ft)
(Socket head screw/Speed sensor)
- Torque limit : 3.1kgf · m(22.1lbf · ft)
(Inductive transmitter)

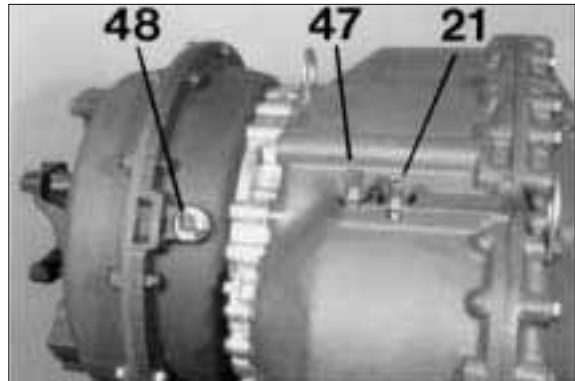

75773TM291

- ③ Install breather(Arrow).

- Torque limit : 1.2kgf · m(8.9lbf · ft)



75773TM292

3. AXLE

1) GENERAL INSTRUCTIONS

(1) SHIMS

All adjustments shall be carried out after all adjustment shims have been selected measuring them one by one with a micrometer gauge and, then, summing up all values measured; don't trust incorrect measurement of pack as a unit or sum of nominal value printed on each shim.

(2) SEALS FOR REVOLVING SHAFTS

Proceed as follows for proper fitting of captioned seals:

- ☐ Prior assembly, seals should be kept, for at least half an hour, in a bath with the same oil to be sealed;
- ☐ Clean thoroughly shaft and make that working surface be not damaged;
- ☐ Position sealing lip against the fluid to be sealed; in case of hydrodynamic lip lines should be oriented so as that, considering direction of revolving shaft, they lead fluid inside of sealing means;
- ☐ Smear sealing lip with a film of lubricant (oil is better than grease) and fill up with grease the space between sealing lip and dust shield lip, if using double sealing lip type seals;
- ☐ Press seal in relevant seat or use a proper fitter with flat contact surface; never use hammer or mallet to mount seal;
- ☐ When press fitting seal make sure that it be correctly driven in relevant seat, i.e., perpendicular with respect to its seat, as fitting is completed make sure, if required, that seal itself be in contact with relevant shoulder;
- ☐ To prevent damage of seal lip when inserting shaft, duly protect component during assembly.

(3) O-RING SEALS

Lubricate O-RING seals at assembly to prevent twisting that would impair correct sealing.

Clean matching surface as follows prior, smearing compound:

- ☐ Remove old deposits using a metal brush;
- ☐ Degrease surfaces by one the following cleaners: trichloroethylene, kerosene or a warm water and soda solution.

(4) BEARINGS

When assembling them it is advisable to proceed as follows:

- ☐ Heat them with 80 to 90 °C before fitting on relevant shafts;
- ☐ Cool them before inserting in relevant external seats.

(5) SPRING PINS

When using split pins be sure that lengthwise cleft be positioned toward stress on pin.

Coil pins don't require specific position.

2) REDUCTION ASSEMBLY

(1) DISASSEMBLY

- Turn the plug toward top position and remove the plug for the air vent. Assemble the plug temporarily.

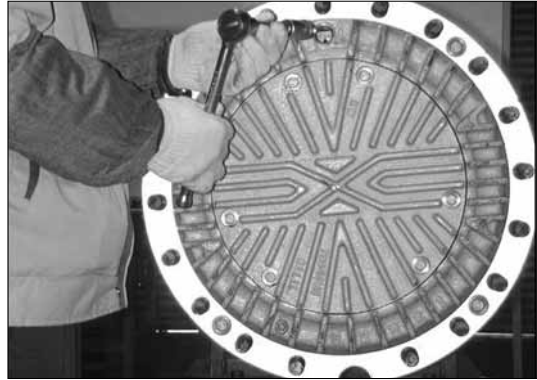

AX001

- Drain oil from final drive unit.

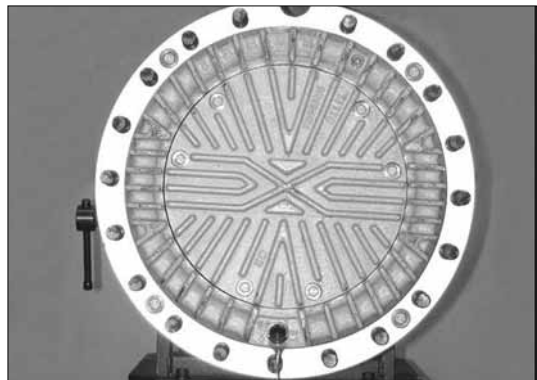

AX002

- Loosen screws securing side gear carrier to wheel hub.

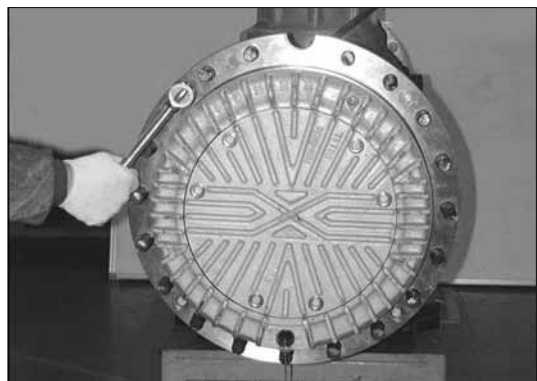

AX003

- Pull out complete side gear carrier.

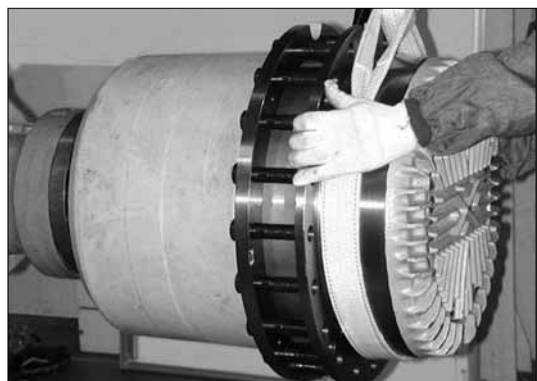

AX004

- ° Pull out wheel shaft with sun gear, discs carrier hub and thrust plate.

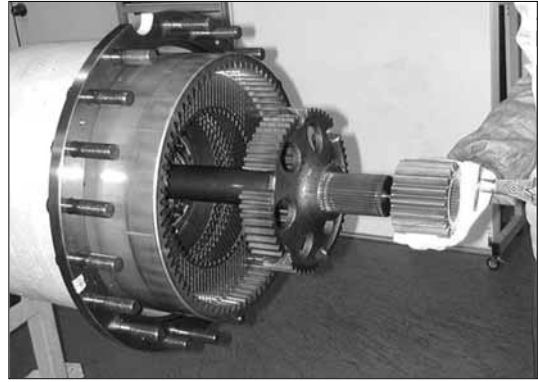

AX005

- Remove brake disc pack.

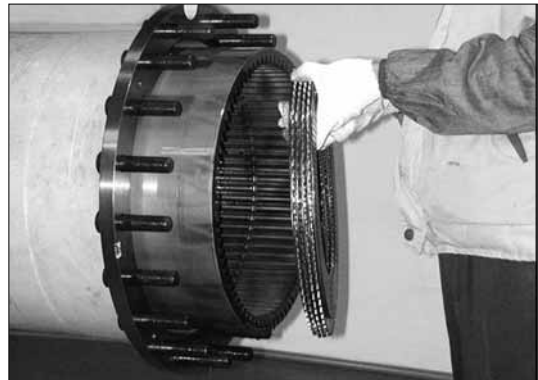

AX006

- Remove lock ring nut locks.

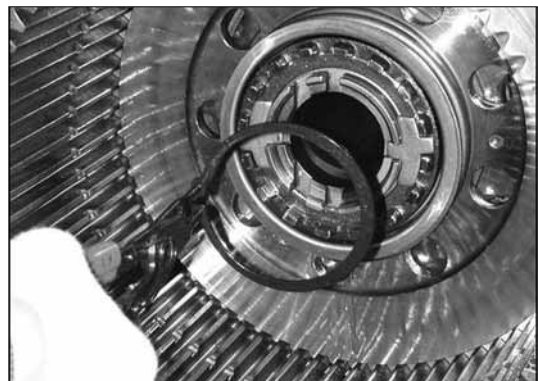

AX007

- Remove locks.

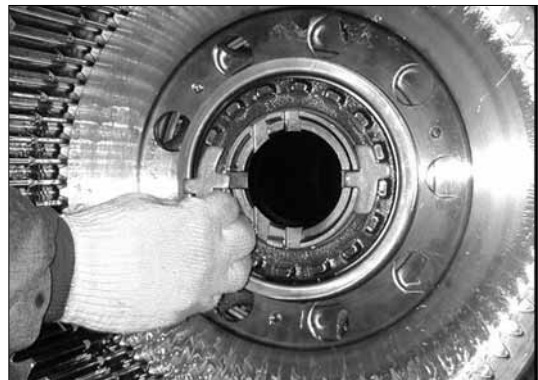

AX008

- Install the proper tool on pressure plate and apply the eye bolt(3EA) temporarily. Tighten the eye bolt tool perfectly.

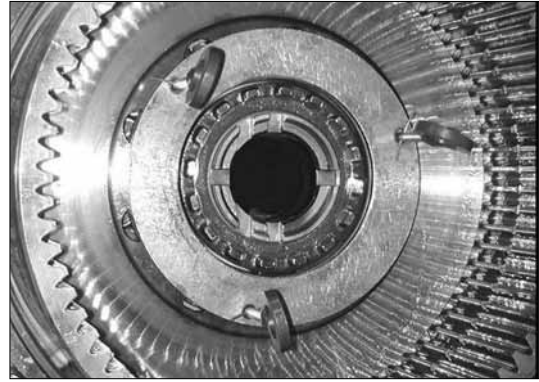

AX009

- Remove the adjusting nut by the use of the special tool.

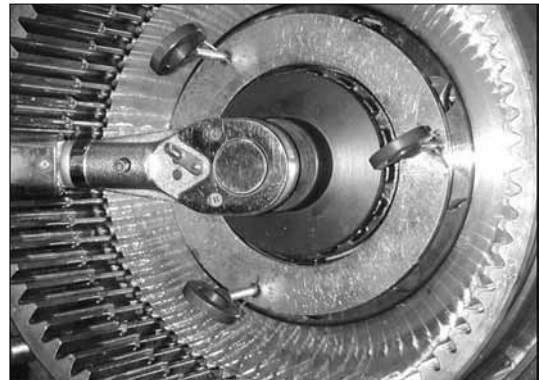

AX0010

- æ Remove the pressure plate, return spring, cover and compression tool.



AX0011

- Remove the ring gear assembly.
- ¡ Attention to the weight.



AX0012

- Pry off lock ring from ring gear by a screw driver and remove ring gear support.



AX0013

- Remove piston, it's easier by blowing compressed air in brake oil delivery ducting.

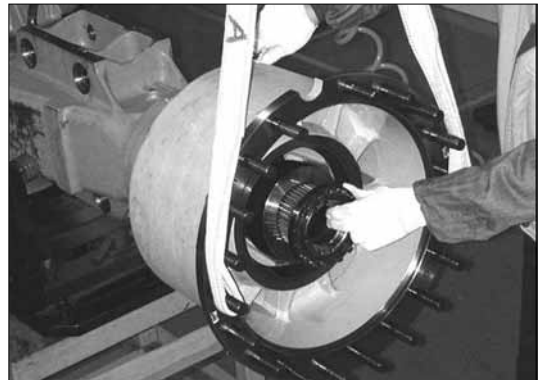

AX0014

- ₁ Remove wheel hub assembly.

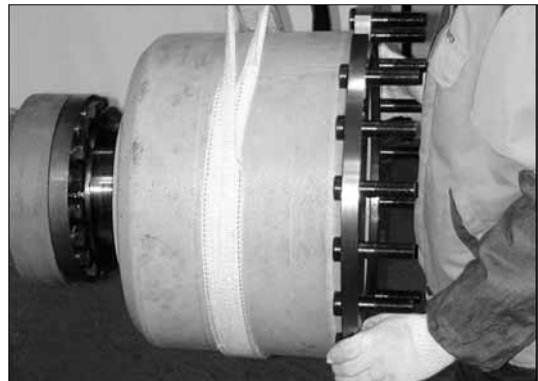

AX0015

- § Pry off wheel hub seal and remove inner race with roller cage of wheel inside bearing. By using a punch remove from wheel hub outer races of inner and outer bearings.



AX0016



AX0017

§æ Remove final drive cover.

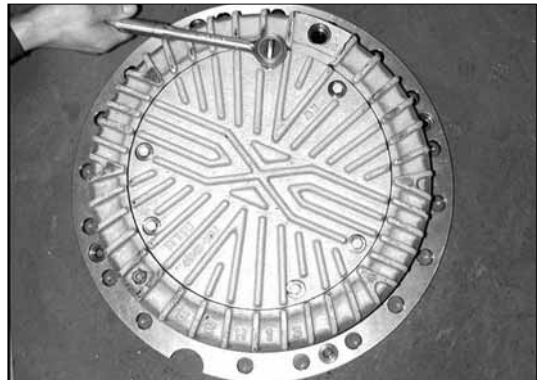

AX0018

§ It is provided with three threaded holes (M10; ± 1.5) to be used for puller screws.

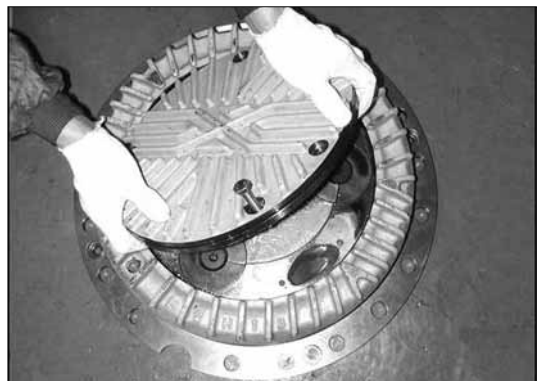

AX0019

§ Remove the planetary pin(3EA) from hub drum(Side gear carrier support) assembly.



AX0020

- § Remove the planetary gear and thrust washer step by step.

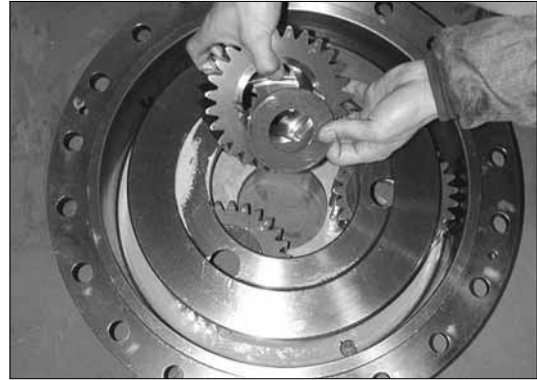

AX0021

(2) ASSEMBLY

- Insert the inner bearing cone.



AX085

- Press fitting lip seal.

- ı Smear loctite 573 or equivalent sealant on outer diameter surface.



AX086

- Support suitably wheel hub while assembling parts to prevent damage of seal; then go on by fitting wheel bearing on hub spindle.

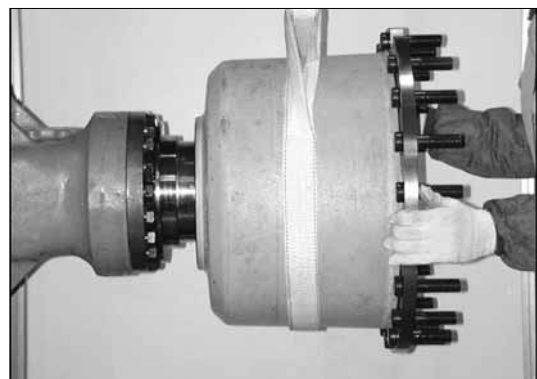

AX087

☒ Replace O-ring seals on piston.

⌋ Cover the oil on O-ring seal enough.



AX088

☒ Insert piston full travel down on hub spindle.



AX089

☒ Insert ring gear support in ring gear, then fit spring ring retaining axle.



AX090

☒ Mount on hub spindle the complete ring gear unit.

⌋ Attention to the weight.



AX091

- Insert into relevant holes the six pins that, for proper operation of whole system, have to be of the same length and however in accordance with relevant drawing.

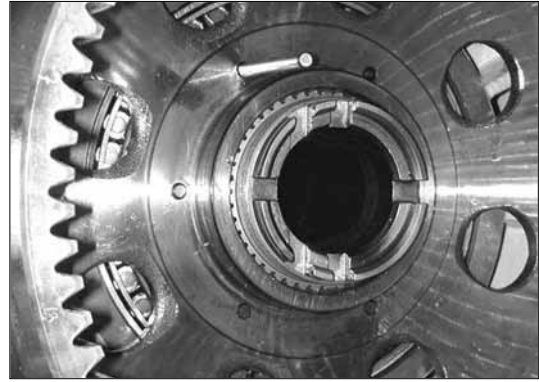

AX092

- Position return spring, cover and spacer on pressure plate, press compression tool. (Front axle only)
- ¡ There is not spacer to the rear axle.



AX093

- Assemble support assembly with spring compression tool on spindle and tighten adjusting nut.



AX094

- æ With proper wrench lock ring so to reach the specified wheel bearing pre-load corresponding to a rotation torque and a rope pull strength on studs included into 15~18kg.

To prevent wrong torque recording, it is advisable to set bearings, by various wheel revolutions, prior performing the check.

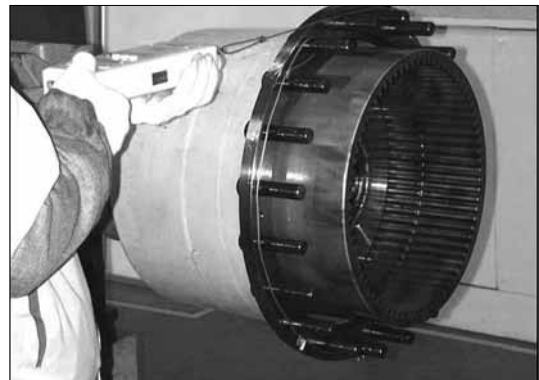

AX095

- Remove spring compression tool.

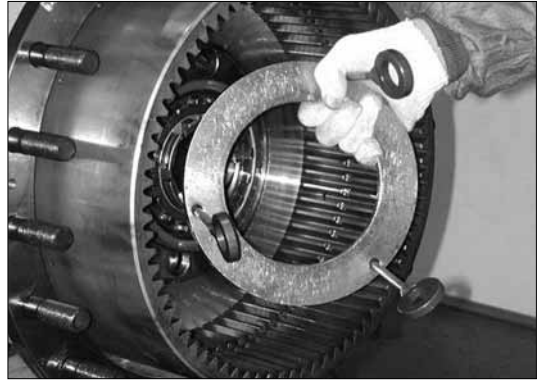

AX096

- Fit plate and assemble retain ring.

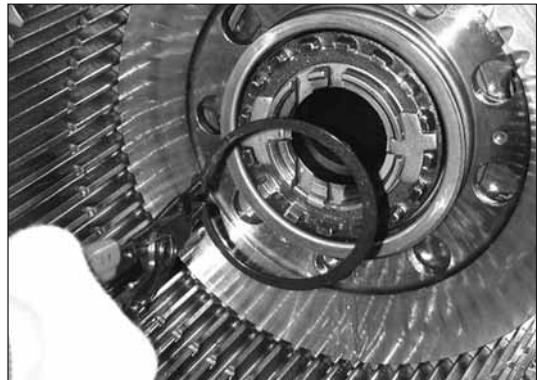

AX097

- Insert wheel shaft on which sequentially mount ; the thrust washer, discs carrier hub, sun gear and lock ring ; then push all components fully down against hub spindle.

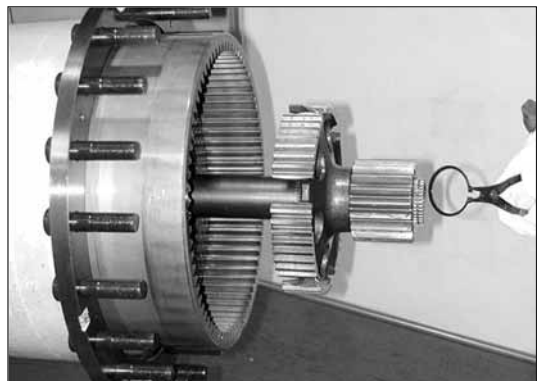

AX098

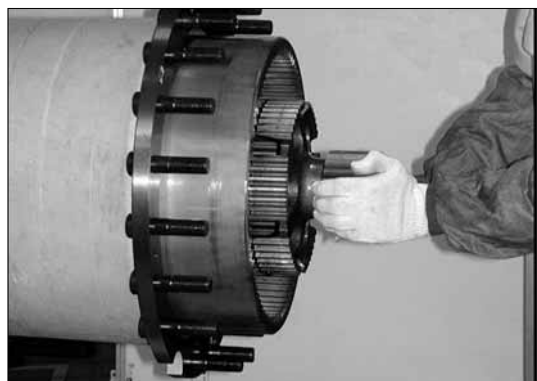

AX099

□₁ Install brake measuring tool on wheel hub.

¡ Distance of brake measuring tool **J**

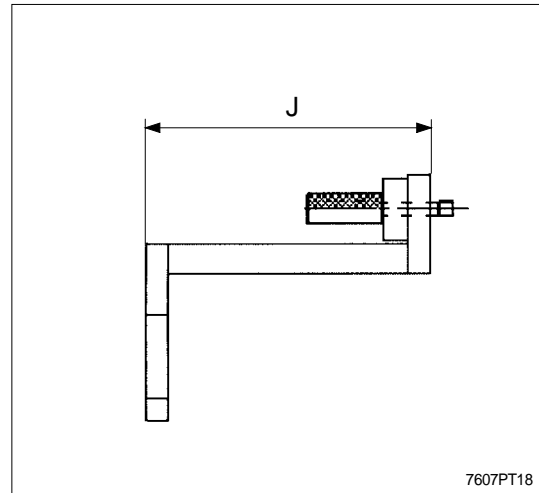

§ Measure **K** between end of measuring tool and pressure plate.

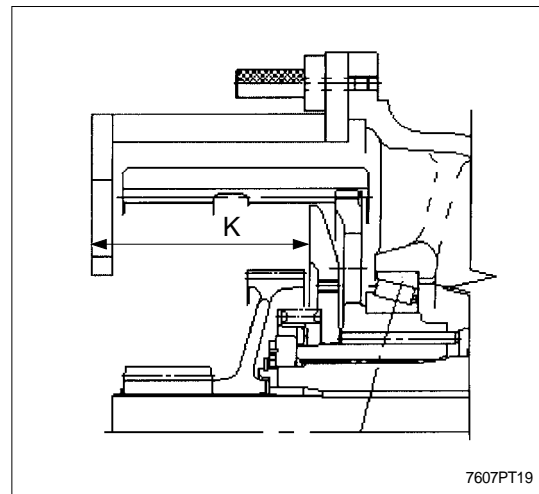

§_æ Install brake measuring tool on hub drum and measure **L**.

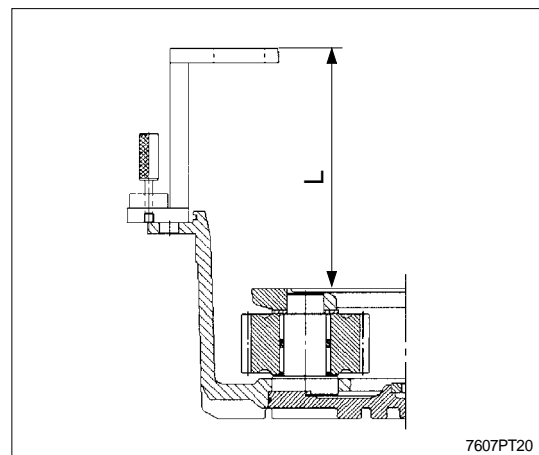

§ To determine thickness of disc pack from previously computed value **M**.

ı Assembly procedure of brake disc pack :
To hub drum from pressure plate **C, B, C, B.....C, B.**(C=disc-count, B=disc-brake)

ı Quantity of brake disc.

ı /Front axle : disc-count 5EA
disc-brake 5EA

ı /Rear axle : disc-count 4EA
disc-brake 4EA

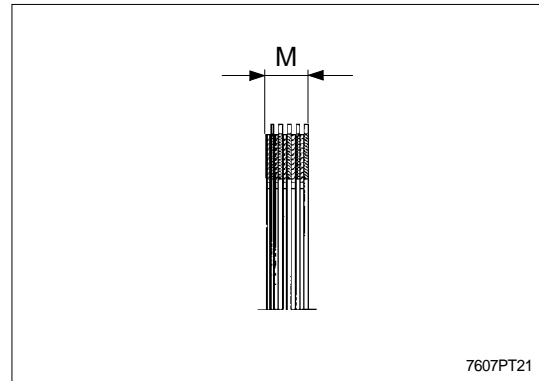

§ Calculate stroke, and if it is not satisfied with the specification, readjust stroke by means of change the thickness of each disc.

$$\text{Stroke} : S=(K+L-2J)-M$$

ı /Stroke

Front axle : 3.5~4.0mm

Rear axle : 3.6~4.0mm

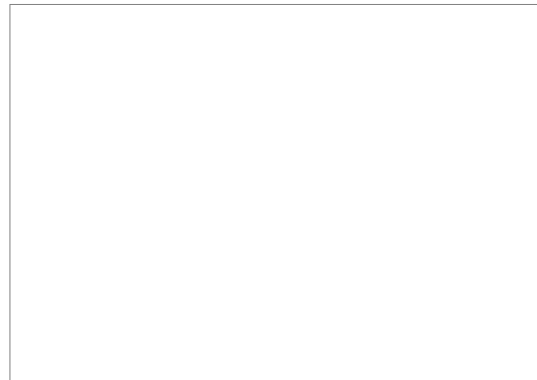

§ Assemble disc pack according to the procedure.

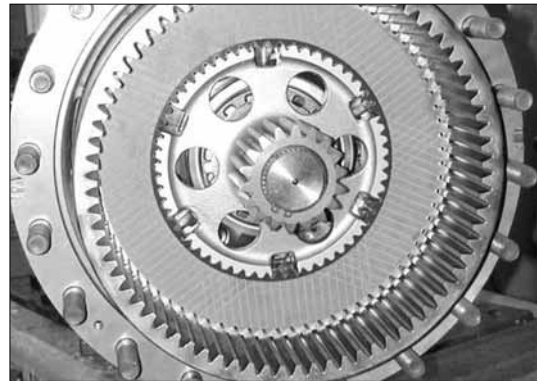

AX104

§₁ Arrange side gear carrier on blocks made of wood and remove pins.

Save needle rollers of filling bearing casings. It is important to keep needle rollers joined with relevant pin for allowance question of pins themselves.



AX105

- § Arrange all the three side gears into relevant seats of side gear carrier, position inner thrust washers and align holes.

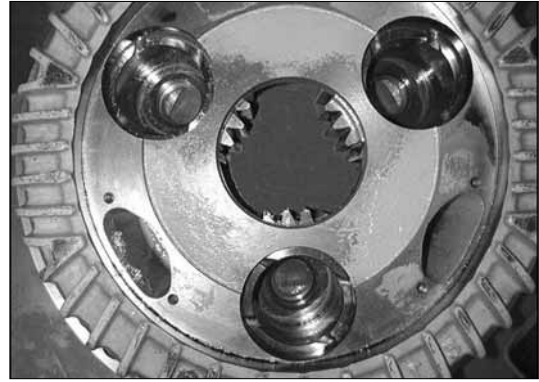

AX106

- § Mount on pins the two needle roller casings. Insert outer thrust washers, grease lower half of pin(head side) and position the first needle roller casing, insert spacer and position the second casing.
- ı In case of needle roller replacement, use needle roller of the same selection class for the two casings of each side gear.



AX107

- § Insert the complete pins, taking care to avoid any bump, cause of needle rollers fall.



AX108

- § Rotate pins so to align them and allow fitting of cover that also prevent pin rotation.

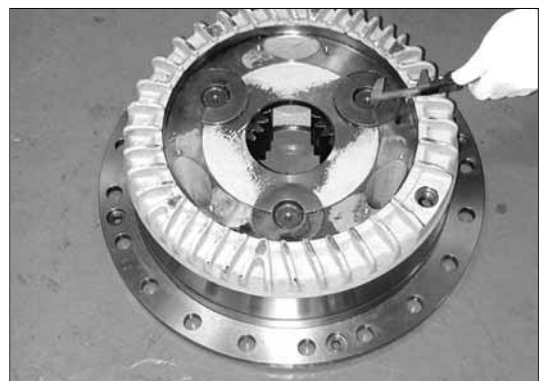

AX109

- §œ Fit O-ring seal on outer side.
- Mount side cover on final drive.
- ¡ Tightening torque
 - Front and rear axle : 2.9~3.6kgf · m
 - (21.0~26.0lbf · ft)

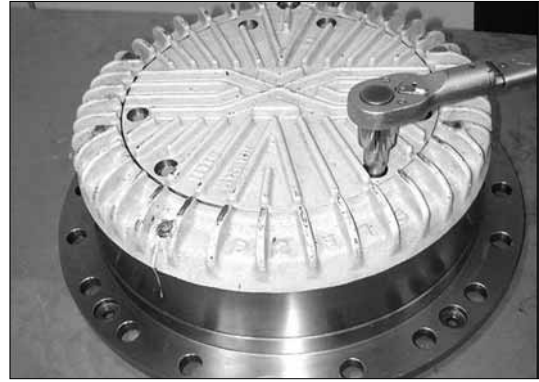

AX110

- §ß Assemble hub drum on wheel hub.

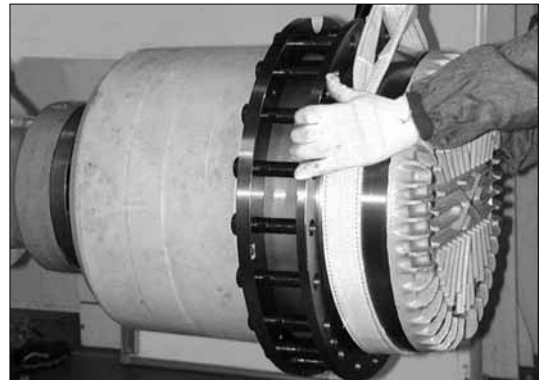

AX111

- § Tight the fixed bolt of hub drum and assemble plug.
- ¡ Tightening torque
 - Front and rear axle : 6.3~6.9kgf · m
 - (45.6~50.0lbf · ft)

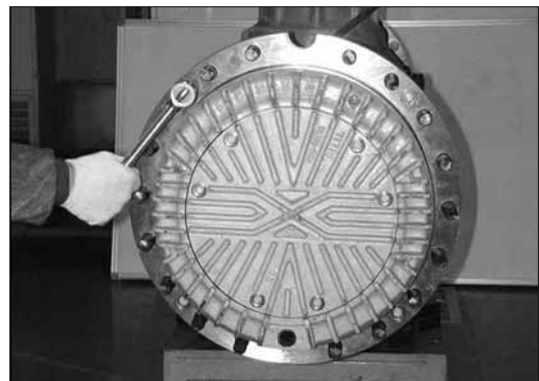

AX112

3) PARKING BRAKE(FRONT AXLE ONLY)

(1) DISASSEMBLY

- Insert through oil adding hole of gripper the pressure of 100~120bar, in order to obtain calipers release.
- Remove the cover bolts of caliper.
- ¡ Brake port size : 7/16¡-20UNF O-ring type



AX022

☞ Release nut and screw.

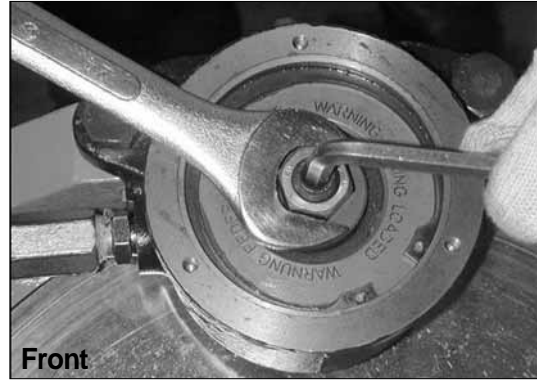

AX023

☞ Remove the split pin and nut of caliper brake. Remove the bolts.

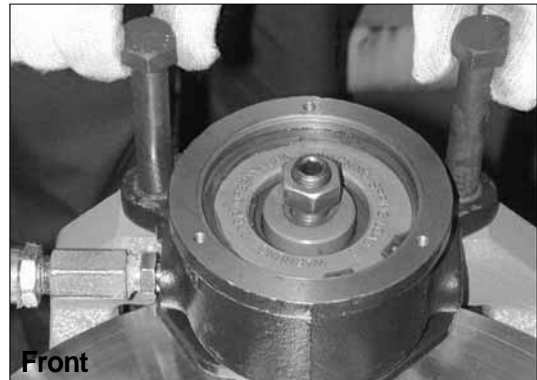

AX024

☞ Remove the caliper brake.

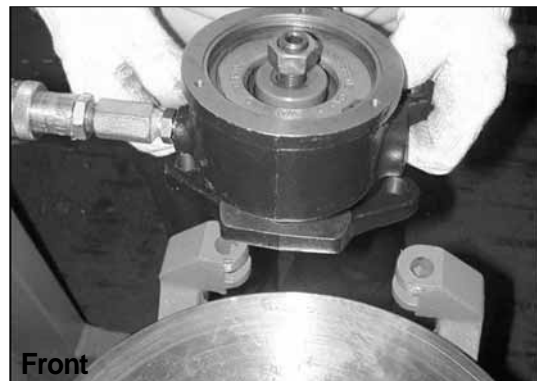

AX025

☞ Remove the disc.

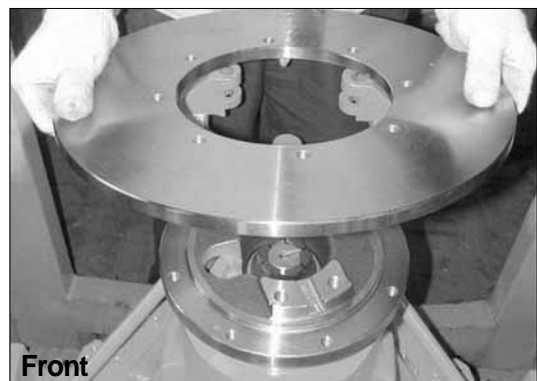

AX026

- Remove the fixed bolts of caliper bracket.



AX027

(2) ASSEMBLY

- Install caliper bracket.
 - ⌋ Tightening torque
14.2~15.7kgf · m(103~114lbf · ft)



AX113

- Fit disc on flange, and tighten bolts.

- ⌋ Tightening torque
6~7kgf · m(43.4~50.6lbf · ft)

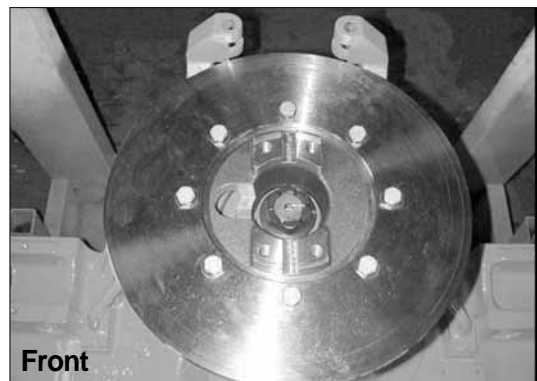

AX114

- Remove cover and O-ring of caliper bracket, and release nut and pin screw.



AX115

- ☐ Release nuts on fixed bolts in order to obtain the maximum opening of gripper.

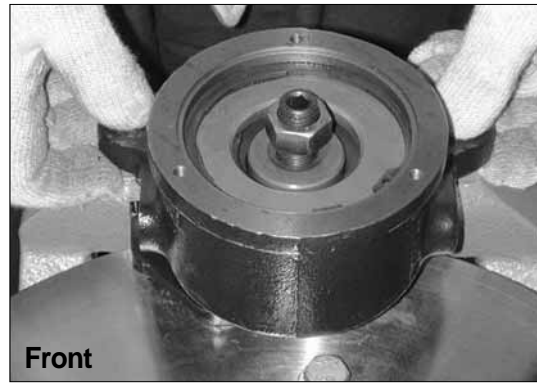

AX116

- ☐ Insert fixed bolts on caliper bracket.

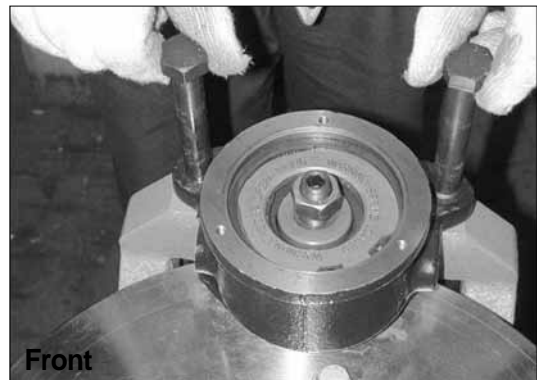

AX117

- ☐ Tighten nuts and split pins.
 - ⌋ Tightening torque
1~3kgf · m(7.2~21.7lb · ft)

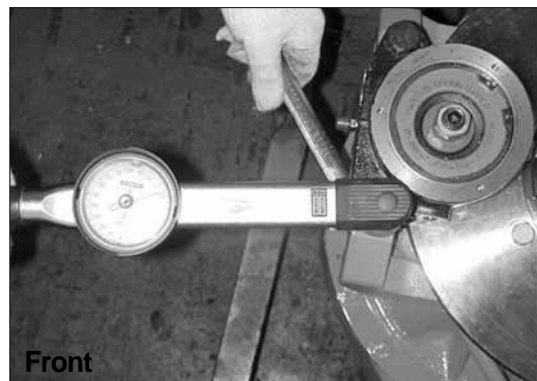

AX118

- ☐ Assemble the bleeder on brake caliper.
 - ⌋ Bleeder tightening torque : 1.4~1.5Kgf · m
(10.1~10.8lb · ft)

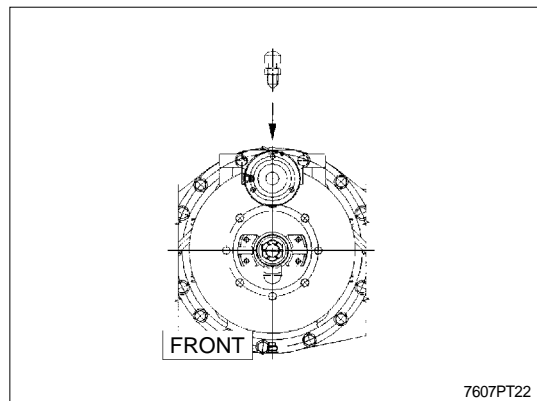

7607PT22

4) DIFFERENTIAL ASSEMBLY

(1) REMOVAL

- Remove screws and take away air recirculation duct from differential support and axle case.(Front axle only)



AX0228

- Loosen the screws retaining differential group, then remove it from axle case.

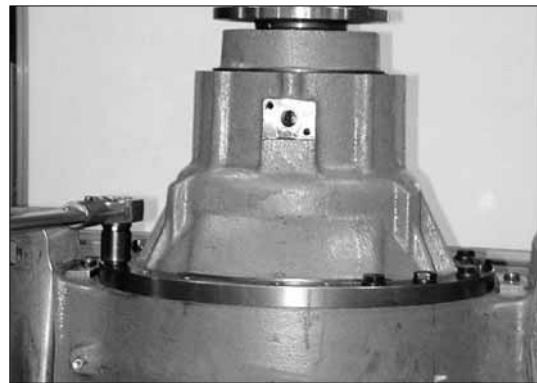

AX029

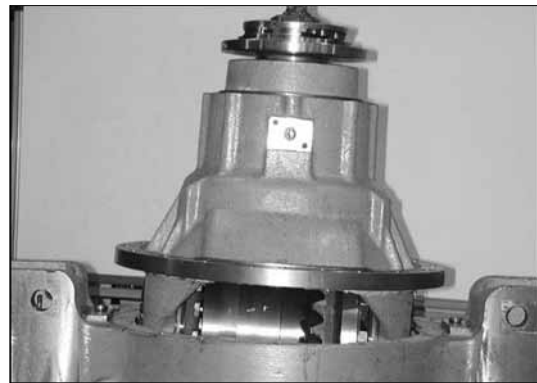

AX030

(2) DISASSEMBLY

- Place differential unit upside down; mark caps position.

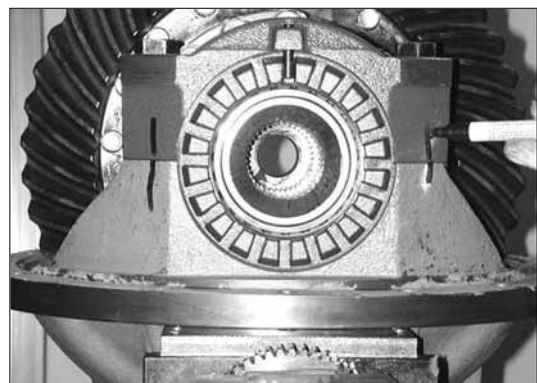

AX031

⊞⊚ Unlock and remove caps fixing screws.

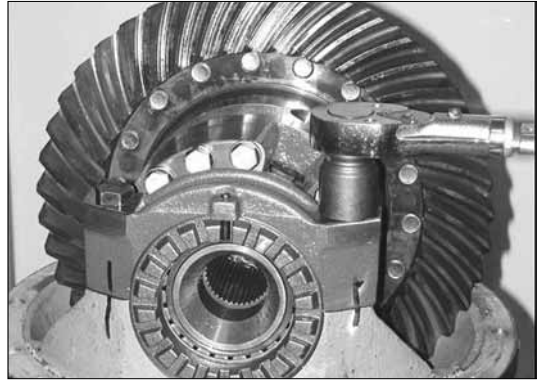

AX032

⊞⊜ Remove lock pin of ring nut, remove caps.



AX033

⊞⊞ Unlock nut and remove screw.
(Rear differential only)



7607AX130

⊞° Remove fixing screws(4EA) of cross beam
assembly. (Rear differential only)

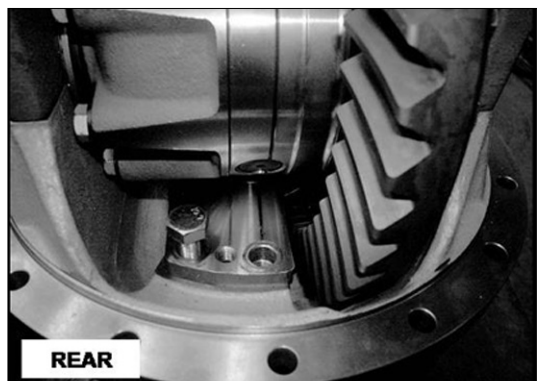

7607AX131

- Install the disassembling bolt on top (M12 x 1.75, 2EA) of cross beam assembly. (Rear differential only)

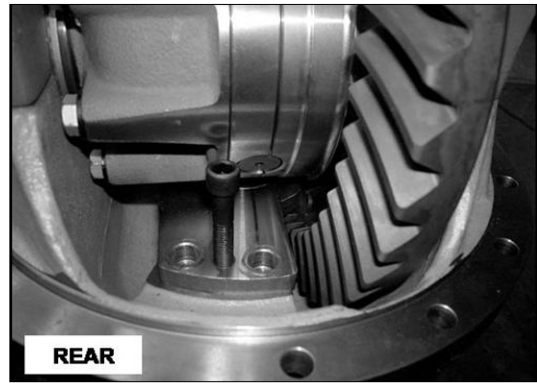

7607AX132

- Lift up differential, cross beam assembly (Rear differential only) from support, by a lifting tool with proper capacity.

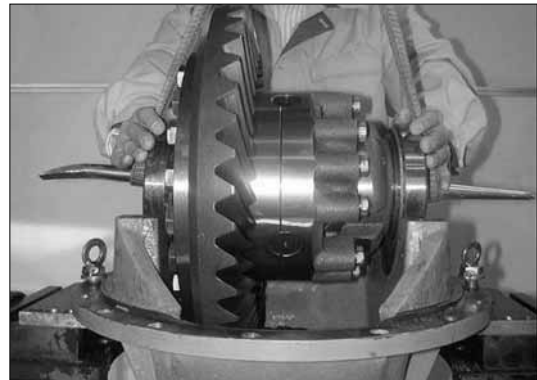

AX034

- Remove pin, washer from cross beam assembly. (Rear differential only)



AX133

- Remove bearing from cross beam. (Rear differential only)



AX134

- Place on proper support and lock the differential. Straighten notches on pinion nut, then position reaction tool on P.T.O. flange and unlock nut; release pinion nut. Remove drive flange from pinion shank.



AX035



AX036

- æ Pry off seal from P.T.O. flange.



AX037

- Drive out bevel pinion from differential support hammering by a proper remover on shank, don't damage thread.



AX038

- Remove the bearing cone.



AX039

- Remove pump and shim.
(Front differential only)



AX135

- ₁ Remove the shim and spacer in removed pinion. (Rear differential only)



AX041

- § Remove shim and bearing cup from differential support, hammer pinion shank by a proper tool, taking care not to damage thread.



AX137

(3) ASSEMBLY

- Measure the dimensions for assembly position of pinion bevel.
Decide the dimension X (shim thickness) by the calculation.

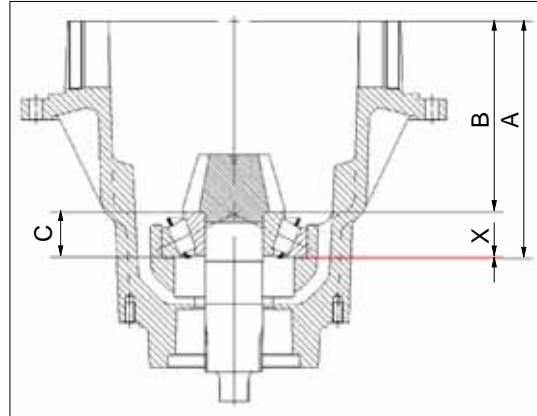

AX043

- Both the bevel pinion and the bevel gear are marked with a number. Confirmed the some numbers both the pinion-bevel and gear-bevel.
- ┆ Number location of bevel set
Bevel pinion : Head surface
Bevel ring : Outer cutting side

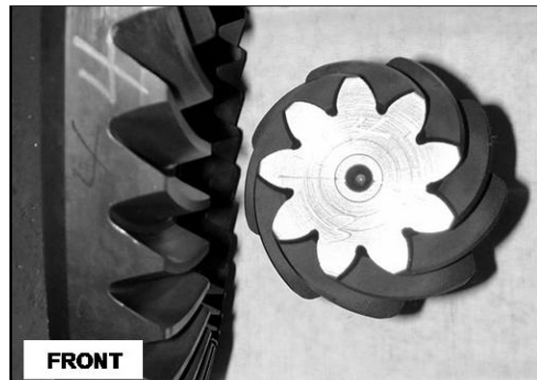

AX138



AX139

- Measure the carrier height **A** by the special tool.

- ┆ Standard value of **A**
 - ┆ Front axle : 263.0mm
 - ┆ Rear axle : 222.0mm

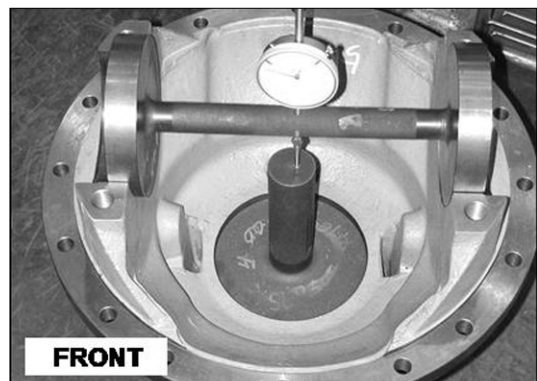

AX140

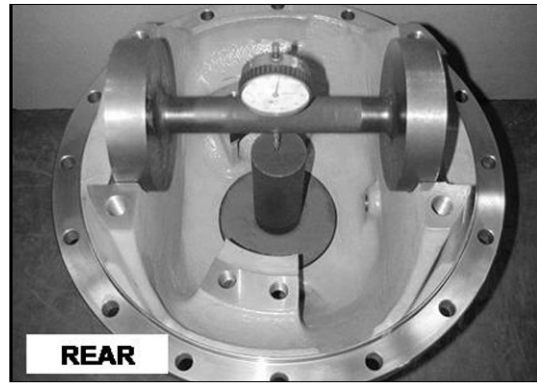

AX141

☐ Decide a value **B** by the carved value of bevel pinion head.

┆ Front axle : $B = 208.0$ ┆ carved value

┆ Rear axle : $B = 184.0$ ┆ carved value

┆ In case, the carved value is -10 , **B** of Front axle $= 208.0 - 0.1 = 207.9\text{mm}$

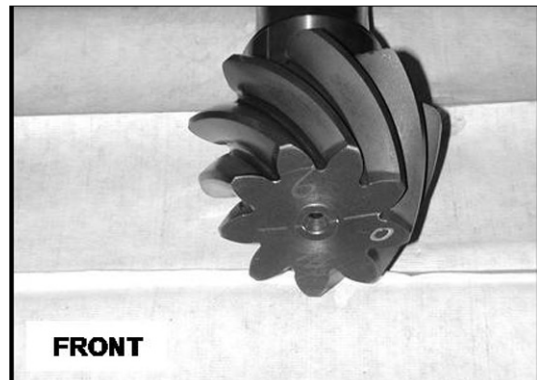

AX142



AX143

☐ Measure the width of bearing **C**.

┆ Standard value of **C**

┆ Front axle : 54.0mm

┆ Rear axle : 37.0mm

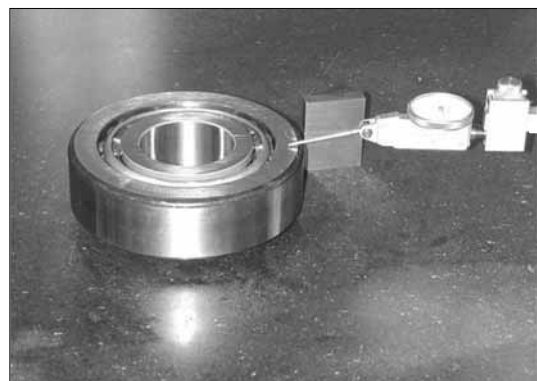

AX047

- Determine shim X thickness for correct axial position of pinion-bevel.

$$X = A - (B + C)$$

- ı Round up or down to the nearest tenth of millimeter the computed thickness.

2.12 rounded down to = 2.1mm

2.18 rounded up to =2.2mm

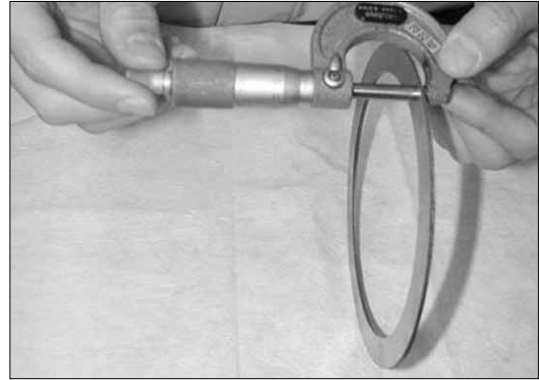

AX144

- Insert adjustment shim for axial position of pinion.

Its value was computed previously ; also, fit outer races of pinion under head and shank bearings.



AX145

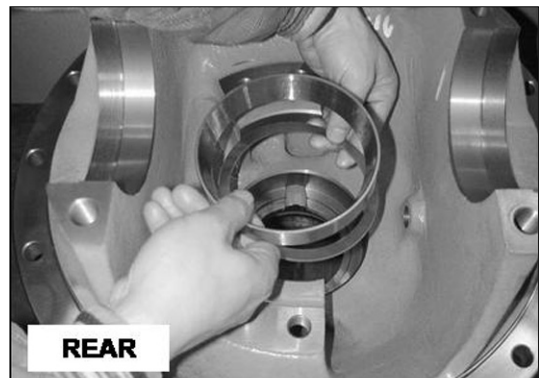

AX146

- Fit in pinion shank inner race of under head bearing, heat or press-in part by installer.



AX049

- Fit in inner race bearing by pressing.

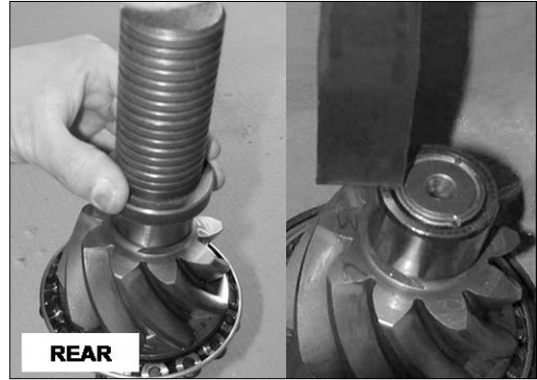

AX147

- Fit in bearing by pressing.
Assemble the pin and washer.
(Rear differential only)



AX148

- æ Assemble the pump and shims(3EA).
(Front differential only)
- Assemble the spacer and shims(2EA).
(Rear differential only)

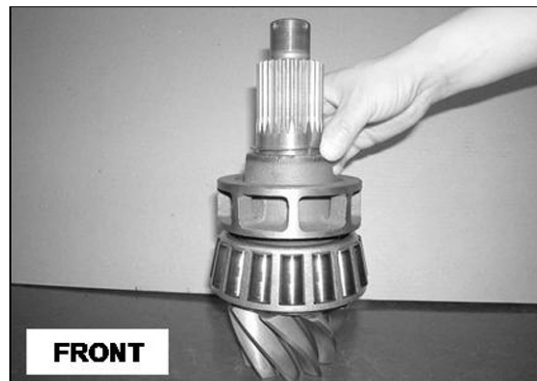

AX149



AX150

□ Turn the carrier upside down and assemble the bevel pinion assembly.

┆ In order to contact between the bearing cone in pinion bevel and the cup bearing of carrier perfectly, support the bevel pinion by preferable tool.

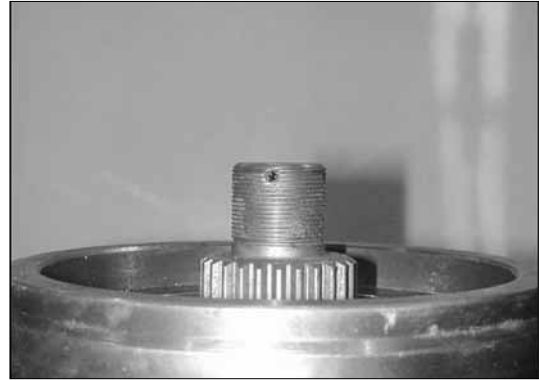

AX052

□ Fit in cone bearing by heating or pressing.



AX055

□ Assemble flange and holder in bevel pinion, and tighten pinion nut.

┆ Don't assemble seal.

┆ Tightening torque : 64~70kgf /m
(463~506lbf /ft)



AX056

□ Measure preload and confirm the follow value.

┆ Bearing preload

┆ Front axle : 0.2~0.4kgf /m

┆ Rear axle : 0.2~0.4kgf /m

┆ Before measuring preload, rotate two or three times. Disassemble and change adjustment shims and spacer(Rear axle only) to eliminate all end play up to reach a pre-load.

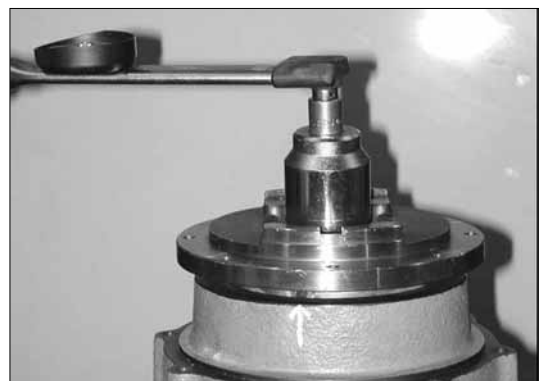

AX057

- § As bearing pre-load has been determined, remove drive flange and pinion nut holder.



AX058

- § Assemble seal.

- ı Cover the seal with retaining compound.
ı Cover the seal lip and the flange with oil.



AX059

- § Assemble the flange and the holder on the bevel pinion, and tighten the pinion nut and the split pin.

- ı Tightening torque : 64~70kgf ; /m
(463~506lbf ; /ft)

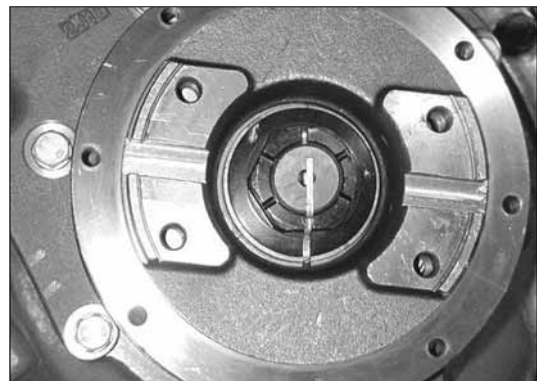

AX060

- § Install cross beam assembly to the location of bolts fixing bevel ring. And then assemble the bearing inner race before mounting differential to carrier.



AX151

§ Tighten the fixing bolt of cross beam assembly.

(Rear differential only)

┆ Tightening torque : 31.3~34.6kgf ; /m
(226~250lbf ; /ft)



AX152

§ 1 Fit in the differential assembly on the carrier, and assemble adjusting nut temporarily.

(Front differential only)

Assemble adjusting nut temporary.

(Rear differential only)



AX061

§ Install caps, care not to reverse position and lock screws fixing to differential support with belows.

┆ Cap tightening torque

┆ Front axle : 63~69kgf ; /m(456~499lbf ; /ft)

┆ Rear axle : 31.3~34.6kgf ; /m(226~250lbf ; /ft)

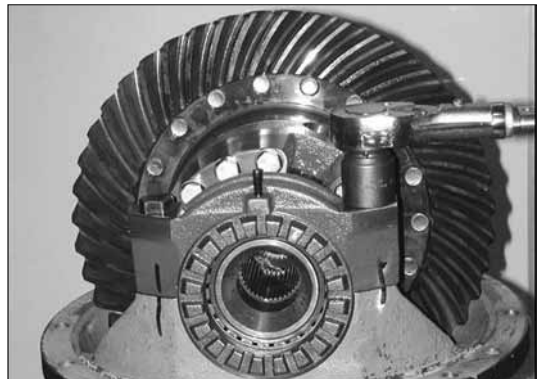

AX062

§ Position a dial gauge perpendicular than ring gear tooth and check, with pinion steady, backlash that has to be of 0.25~ 0.33mm (front) and 0.20~0.28mm(rear).

Otherwise rotate both ring nuts by displacing them of the same number of notches and nearing ring gear to pinion if backlash is excessive, by moving away on the contrary.

┆ Bevel set back lash

┆ Front axle : 0.25~0.33mm

┆ Rear axle : 0.20~0.28mm



AX063

§1 Brush red lead on some ring tooth, rotate to mesh pinion and ring gear repeatedly, so to make evident tooth contact. Proper and correct tooth contact marks are visible on a new bevel gear set as a result of an optimum contact approached on the tester, consequently, a proper axial position of pinion against ring gear will emphasise remarking of previous tester contact markings.

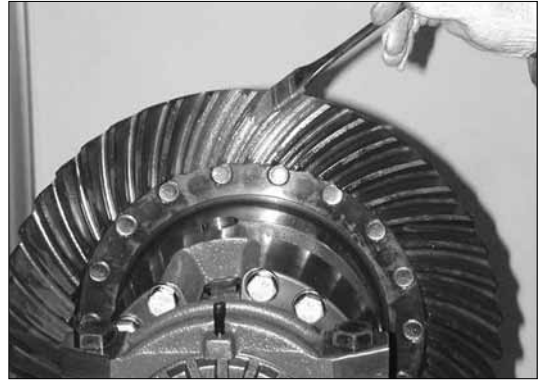

AX064

§2 Fit spring pins locking threaded rings of differential unit.

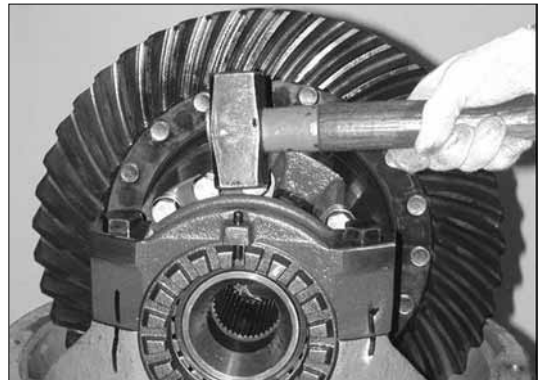

AX065

§3 Apply flange sealant on the screw.
Tighten the screw until contacting the bevel gear and then loosen about 60 ; before tightening nut.

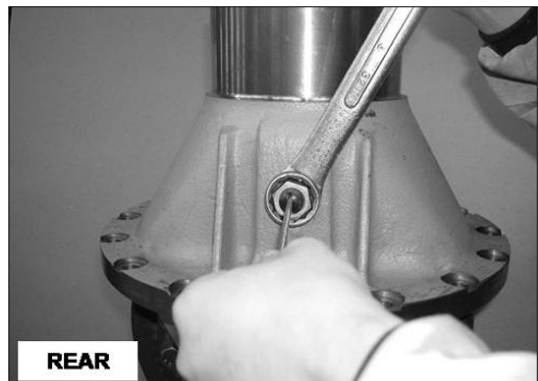

AX153

(4) HOUSING AND DIFFERENTIAL MOUNTING

□ Perform two securing notches on pinion nut.
Clean with care contact surfaces, apply hard locking compound and then install the differential unit on axle case ; lock the connecting screws with a torque of 18.0~20.0Kgf · m(130~145lbf · ft).

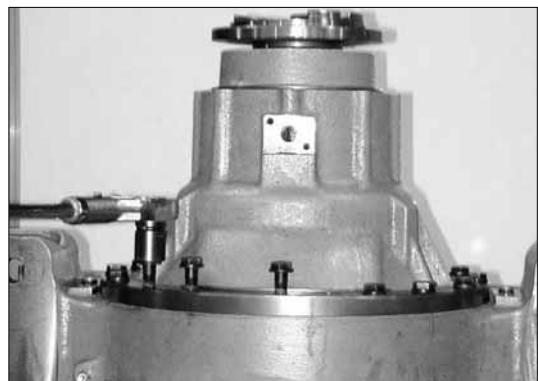

AX065

- ㄤ Assemble O-ring on tube assembly port(3EA).
(Front axle only)

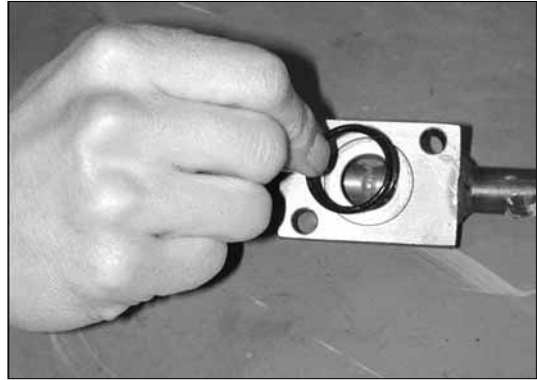

AX083

- 0 Position the tube assembly, fit screws and lock with a torque of 3.0~3.6Kgf · m(21.7~26.0lbf · ft).
(Front axle only)



AX084

5) SUPER MAX TRAC

(1) DISASSEMBLY

- Mark the two half cases(LH/RH).



AX154

- ㄤ Loosen the bolts of the case(RH) and remove the case(LH).



AX155

⊘ Remove the side gear and the thrust washer.



AX156

⊘ Remove spider with the four side gears and relevant bevel thrust washers.



AX157

⊘ Remove the planetary gear with relevant intermediate and shim discs and clutch discs, in half case on bevel gear side.



AX158

⊘ Loosen bevel gear fixing screws.



AX159

(2) ASSEMBLY

- Install gear-bevel on case(LH) by bolts.
- ┆ Tightening torque
 - ┆ /Front axle : 45.6~50.4kgf ; /m(330~365lbf ; /ft)
 - ┆ /Rear axle : 31.3~34.6kgf ; /m(226~250lbf ; /ft)



AX160

- Insert side gear assembly and thrust washer in case(LH).
Assemble spider and side gear according to procedure.



AX079

- Mount the cover, taking care to align the reference marked done before disassembling ; close the two half casings.
Screw in fixing screws and lock a torque of ;
 - ┆ /Front and rear axle : 11.4~12.6kgf ; /m
 - ┆ (82.5~91.1lbf ; /ft)



AX162

6) TOOLS

- Spring compression tool.

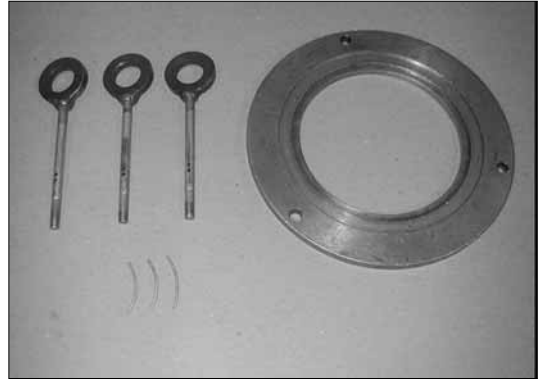

AX124

- Nut adjusting tool of reduction assembly.



AX125