

GROUP 4 DISASSEMBLY AND ASSEMBLY

1. BRAKE PUMP

1) STRUCTURE

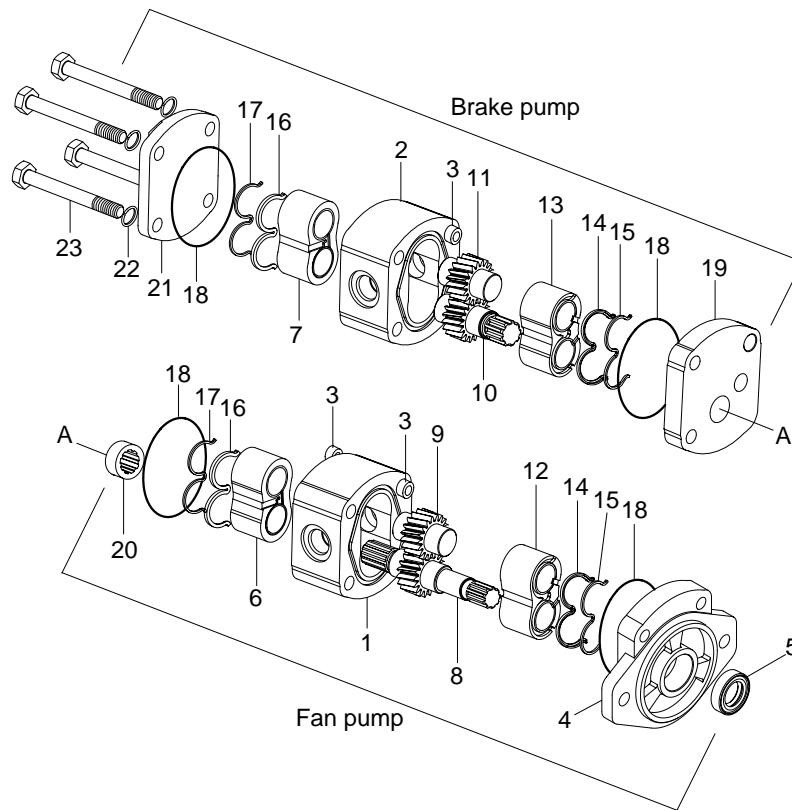

- | | | | | | |
|---|-------------|----|--------------|----|--------------------|
| 1 | Body | 9 | Driven gear | 17 | Backing ring |
| 2 | Body | 10 | Driver gear | 18 | Body O-ring |
| 3 | Dowel pin | 11 | Driven gear | 19 | Intermediate plate |
| 4 | Front cover | 12 | Bushing | 20 | Coupling |
| 5 | Shaft seal | 13 | Bushing | 21 | Rear cover |
| 6 | Bushing | 14 | Bushing seal | 22 | Spring washer |
| 7 | Bushing | 15 | Backing ring | 23 | Screw |
| 8 | Driver gear | 16 | Bushing seal | | |

7707BS19

2) DISASSEMBLY

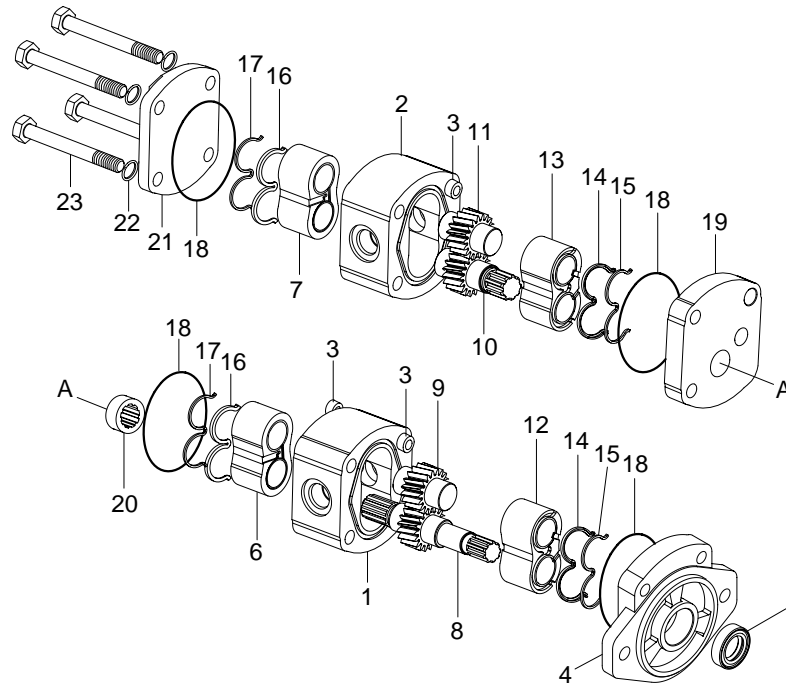

7707BS25

Before disassembling ensure that the unit itself, bench and tools are thoroughly clean.

- (1) Lightly mark the rear cover(21), body(2) and plate(19) to ensure reassembly in the correct position.
- (2) Remove the bolts(23) and separate the brake pump unit from the fan pump using a soft faced hammer.
- (3) Remove splined coupling(20).
- (4) Remove the plate(19) from the body(2), free from plate using a soft faced hammer.
- (5) Remove the backing ring(15), the seal element(14) and the body O-ring(18).
- (6) Remove the rear cover(21) from the body(2).
- (7) Remove the backing ring(17), the seal element(16) and the body O-ring(18).
Before removing the internal components each bushing(7, 13) must be marked to denote its location within the body. On the plain area of the bush away from the seal location, lightly mark.
- (8) With the unit laying on its side grasp hold of the drive shaft(10) and pull it squarely out of the body(2) bringing the bushing(13) with it.
- (9) Remove the driven gear(11) and the remaining bushing(7).

3) INSPECTION AND REPAIR

(1) Assessment

Each components should be thoroughly cleaned, carefully examined and assessed for suitability re-use. Below is a guide for inspecting the various components.

(2) Body

Inspect the body bore cut-in where both gears wipe into the body.

The body can only be re-used if the **cut-in** is bright and polished in appearance and the depth does not exceed 0.15mm(0.006").

The body should be replaced if the surface is scored, has a matt appearance or shows signs that the tip of the gears have dug in and torn away the surface material.

The body should be inspected to ensure that there is no superficial damage which may adversely effect performance or sealing. Pay particular attention to the port threads and body O-ring seal recesses.

(3) Plate and cover

The inner surfaces should be inspected to ensure that there is no unusual wear or scoring in the regions where the body O-rings and backing rings contact, which result in external leakage.

Check the shaft seal recess for scoring or damage that could result in oil leakage around the outer diameter of the shaft seal. Replacement shaft seals can be refitted with Loctite hydraulic sealant to overcome slight damage in this area.

(4) Bushes

The side faces which abut the gears should be perfectly flat showing no sign of scoring. Characteristically there are bright polished areas on this surface caused by loading against the gear side faces, which is often more pronounced on the low pressure side. The bush should be replaced if there is any general scoring or fine scoring with a matt appearance or tearing of the surface material. Often there is a witness where the tips of the opposing gears have wiped an overlap reassembling a half moon shape. There must be no noticeable wear step as it is critical that the bush side face is completely flat to the gear side face.

The bearing liners are acceptable providing that they are not scored or show other damage. The general outside area of the bush should not show any prominent signs of wear.

(5) Gears

The gear side faces should be examined for bruising or scoring. Often operation on contaminated fluid shows scoring between the root of the gear and the journal undercut, which leaves a wear step. If a wear step can be felt, coincidental with the root diameter, by drawing a sharp pointed tool across the surface from the undercut outwards towards the tip of the gear, then the gear is unserviceable.

The gear teeth should then be carefully examined to ensure that there are no signs of bruising or pitting.

The journal bearing surfaces should be completely free from scoring or bruising. The surface should appear highly polished and smooth to touch.

Examine the area where the shaft seal lips run on the drive shaft, this shows up as a polished ring or rings. If a noticeable groove can be felt or there is scoring the shaft should be replaced.

Provided the drive shaft is not damaged from the drive-coupling and the gears have not been harmed as described above, then the gears can be re-used. If, however, the gears are damaged they must be replaced as a matched pair.

As a matter of good practice, when pumps have been disassembled, all the seals should be

4) ASSEMBLY

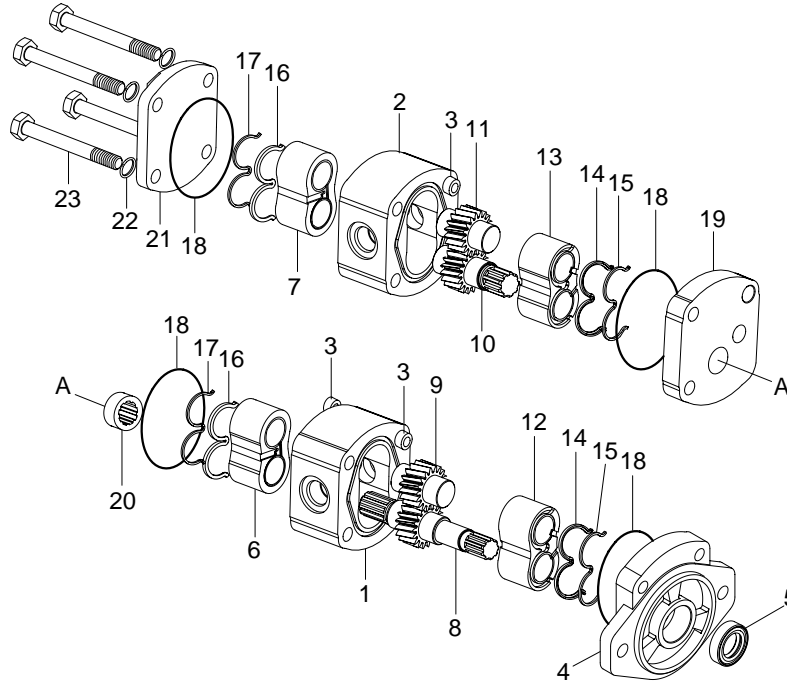

7707BS25

Ensure that all parts are perfectly clean and lightly lubricate the bushes and gears with hydraulic oil (Ensure body O-ring recess and end faces remain free from oil). This will assist with their assembly when they are later fitted into the body.

- (1) Refit the bushing(7) into the undowelled end of the body(2) from where they were removed.
- (2) Place the rear cover(21) against the body(2) and then stand the assembly on the cover so that the hollow dowels are uppermost, i.e. the bushing should be at the bottom with the bushings against the cover.
- (3) Fit the drive shaft(10) and driven gear(11) back into their original positions in the body(2).
- (4) Refit the plate bushing(13) into their original bores.
- (5) Fit the new body O-ring(18).
- (6) Fit the new seal element(14) and backing ring(15) to the bushing.
- (7) Carefully refit the plate(19) to the body(2). If the plate(19) is not fitted squarely the backup seal(14) may become misplaced and trapped, resulting in internal damage if the unit is run in this condition.

ASSEMBLY

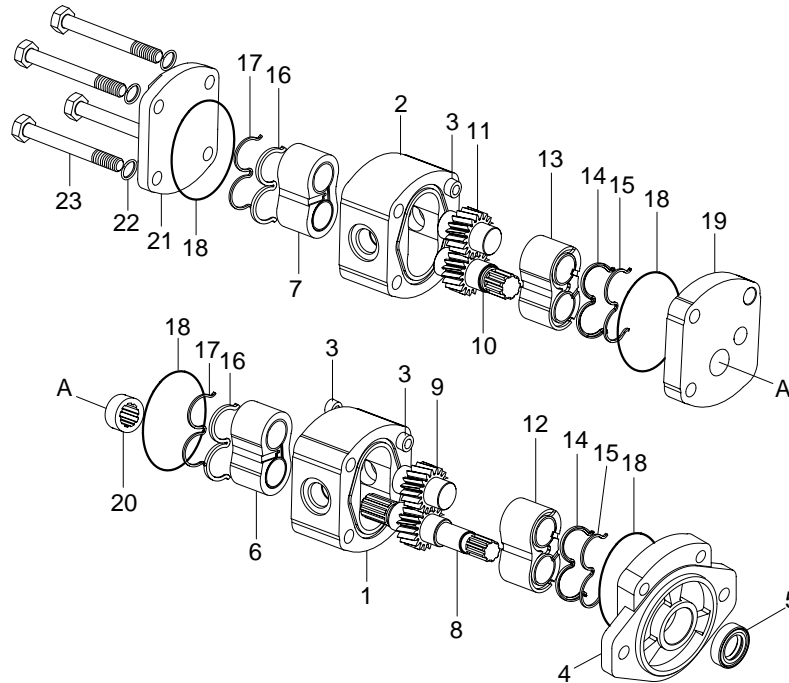

7707BS25

- (8) Fit coupling(20) to the plate(19).
- (9) Holding the whole unit together carefully turn it over, making sure it is supported on the spacer plate(19) not the shaft.
- (10) Slide off the rear over and fit seals as in(5) and (6) above.
- (11) Fit the rear cover(21), taking care not to dislodge the backup seal(16) and bolt(23) the unit together.
 - Tightening torque : 4.8kgf · m(35lb · ft)Pour a small amount of oil into a port and check that the shaft can be rotated without undue force using a smooth jawed hand wrench hooked around the shaft or a suitable half coupling locked against the key.

5) RUNNING-IN

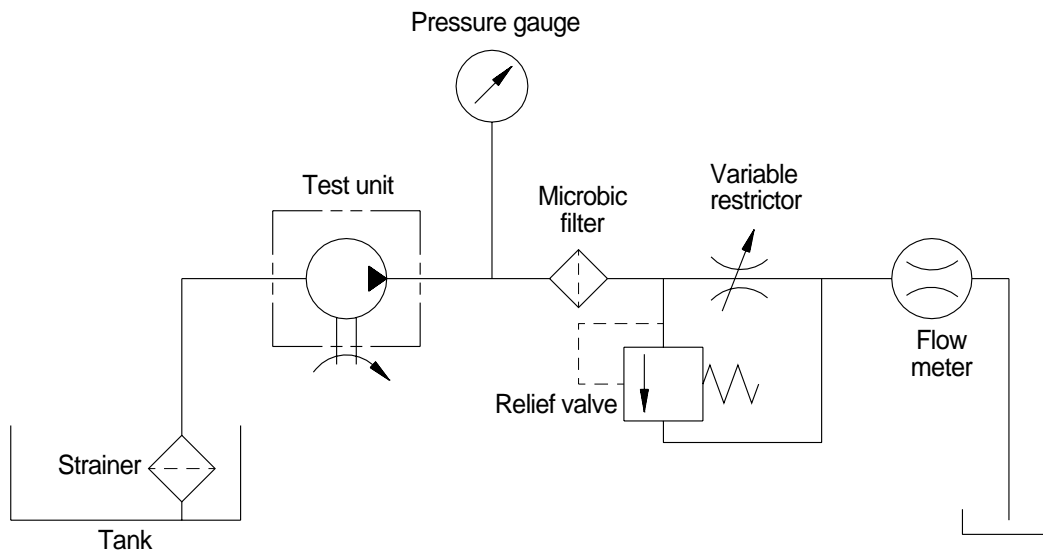

(730TM-3C) 4-48

- (1) A unit which has been re-assembled with either new gears, bushes or body, must be carefully run-in before it is subjected to full working conditions.
- (2) Ideally this should be done on a test rig(See figure) where pressure can be gradually applied and any wipings from the body cut-in arrested by filters.
- (3) It is recommended that the unit is run-in at 1500rpm, initially, at zero pressure for one minute then in stages with the pressure increased by 500psi every minute, until maximum rated pressure has been attained. Frequently check the system temperature, ensuring that it does not exceed the maximum permissible figure of 80 °C. If the temperature exceeds the system or unit specification the test must be delayed and operated off-load until acceptable temperatures are obtained.