

## GROUP 4 DISASSEMBLY AND ASSEMBLY

### 1. CONTROL VALVE

#### 1) DISASSEMBLY

(1) Illustration on the right shows the complete control unit.

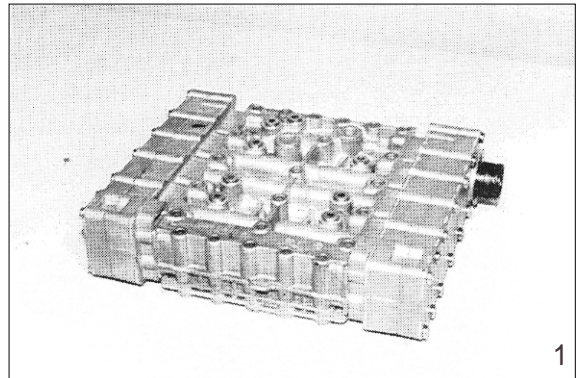

(2) Mark the installation position of the different covers, the housing and cable harness with the valve housing.

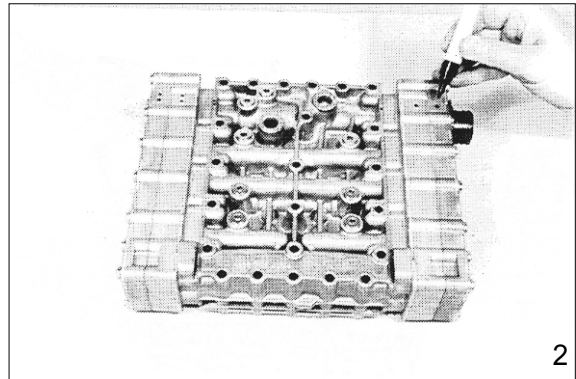

(3) Loosen socket head screws.  
Separate duct plate, 1st gasket, intermediate plate and 2nd gasket from the valve housing.  
Box spanner 5873 042 002

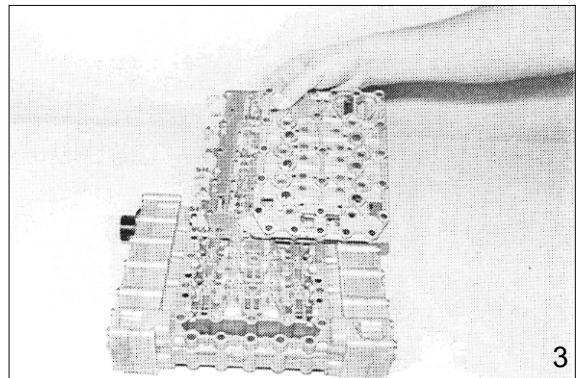

(4) Remove retaining clip.

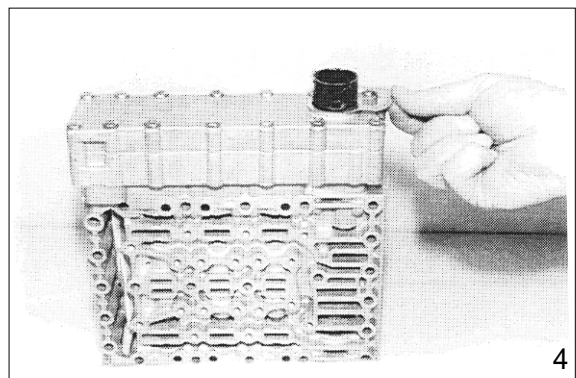

- (5) Loosen socket head screws.  
Separate cover from housing and cable harness.  
Box spanner 5873 042 002

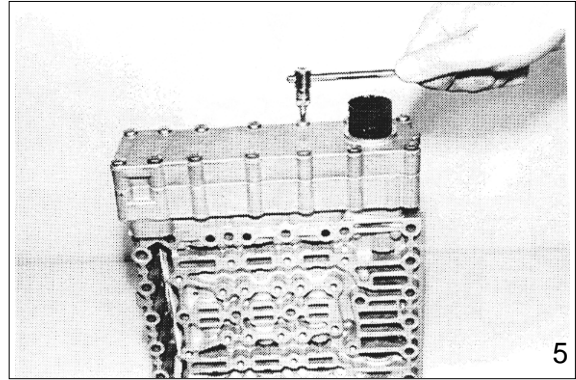

- (6) Disassemble opposite cover.  
Disconnect pressure regulator and remove cable harness.

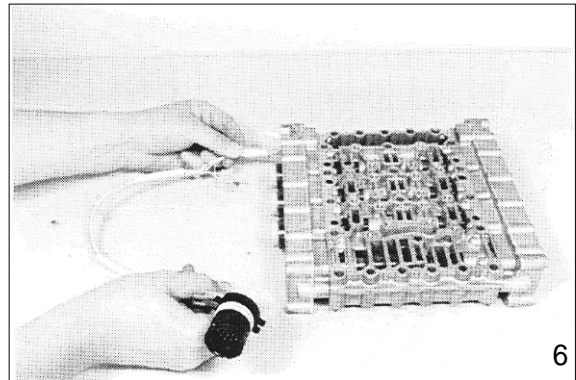

- (7) Loosen socket head screws, remove fixing plate and pressure regulators(3EA).  
Box spanner 5873 042 002

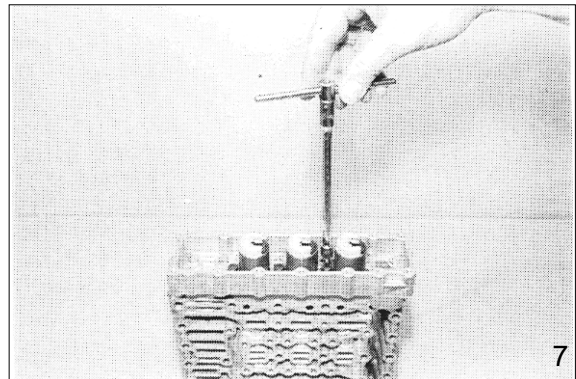

- (8) Loosen two socket head screws and locate housing provisionally, using adjusting screws(Housing is under spring preload).  
Now, loosen remaining socket head screws.  
Box spanner 5873 042 002  
Adjusting screws 5870 204 036

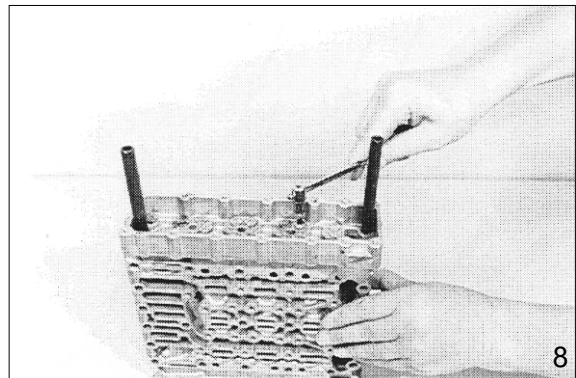

- (9) Separate housing from valve housing by loosening the adjusting screws uniformly.  
Adjusting screws 5870 204 036

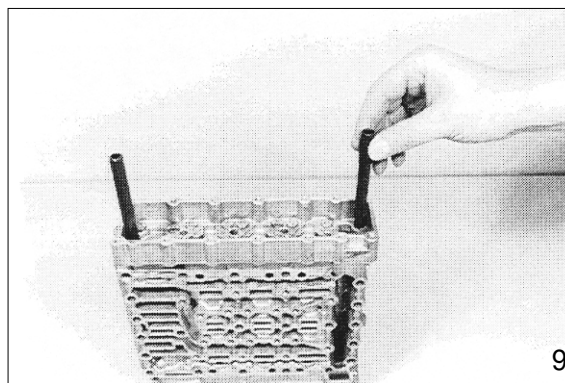

- (10) Remove components.

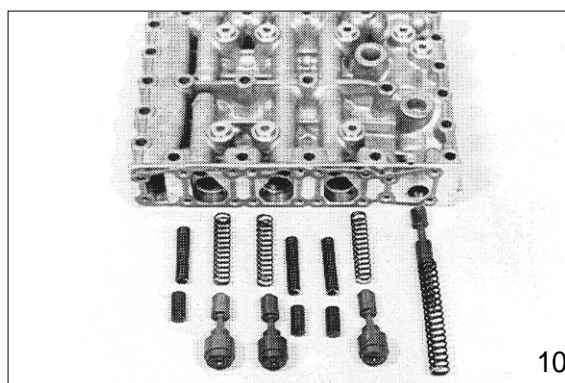

- (11) Remove opposite pressure regulators, housing as well as components accordingly.

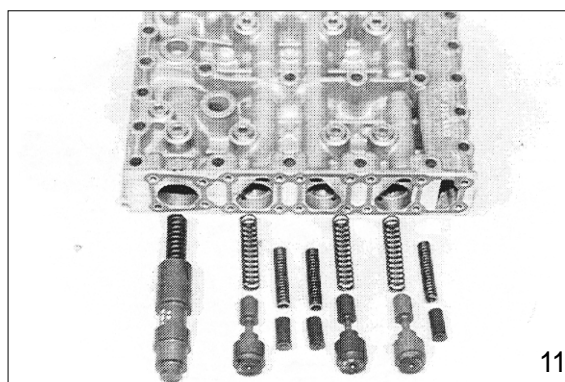

## 2) ASSEMBLY

Check all components for damage and renew if necessary.

Prior to the installation, check free travel of all moving parts in the housing.

Spools can be exchanged individually.

Oil the components prior to the assembly.

Insert diaphragms with the concave side showing upward until contact is obtained.

Installation position, see arrows.

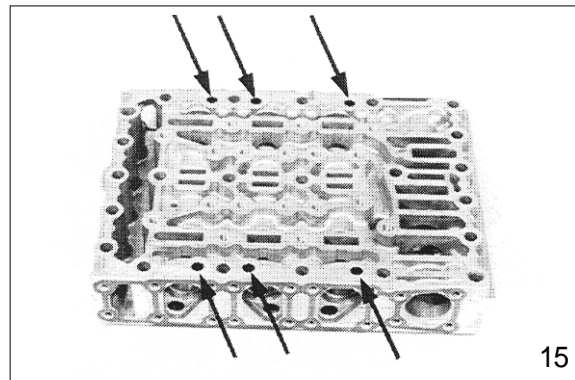

(1) Illustration on the right shows the following components.

- 1 Vibration damper
- 2 Follow-on slide
- 3 Pressure reducing valve

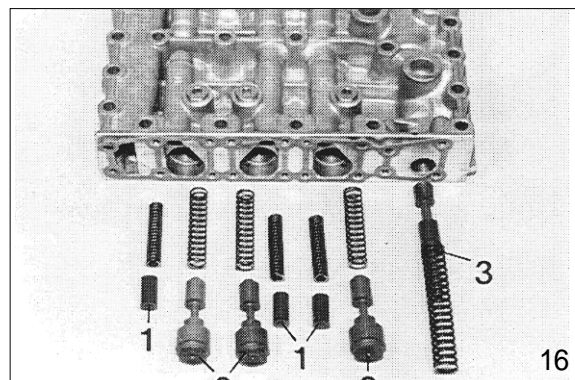

(2) Install components according to figure (1). Preload compression spring of the follow-on slides and locate spool provisionally by means of cylindrical pins  $\varnothing 5.0\text{mm}$  (Assembly aid), see arrows.

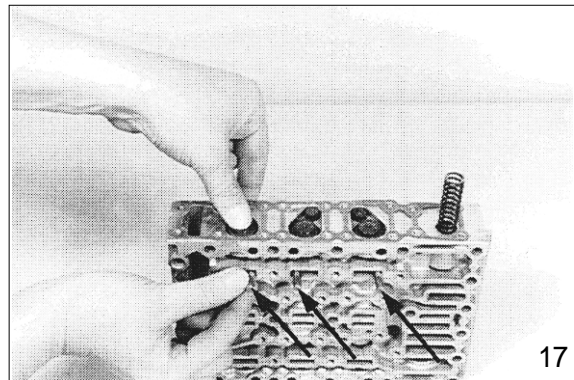

(3) Install two adjusting screws. Assemble gasket (Arrow 1) and housing cover. Now, position the housing cover uniformly, using adjusting screws, until contact is obtained and remove cylindrical pins (Assembly aid) again (See the next figure).

Pay attention to the different housing covers. Install recess  $\varnothing 15\text{mm}$  (Arrow 2), facing the spring of the pressure reducing valve.

Adjusting screws 5870 204 036

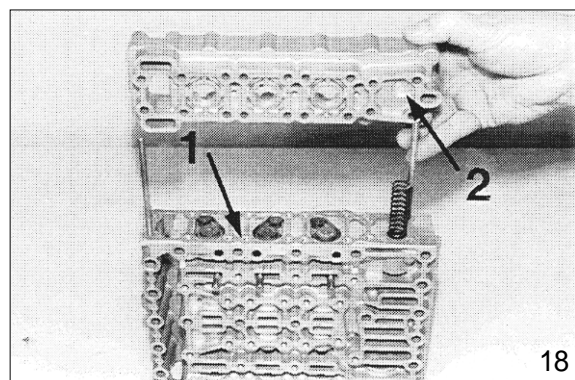

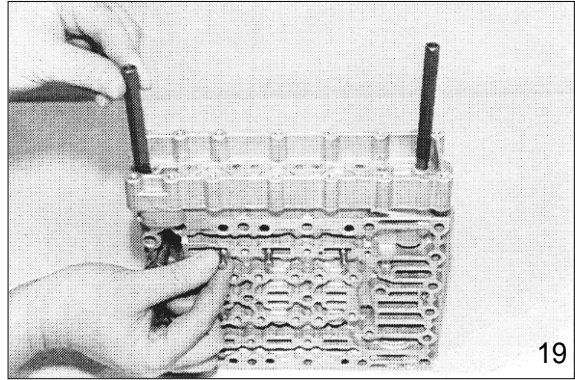

- (4) Fasten housing cover by means of socket head screws.  
 · Torque limit : 0.56kgf · m(4.06lbf · ft)  
 Box spanner 5873 042 002

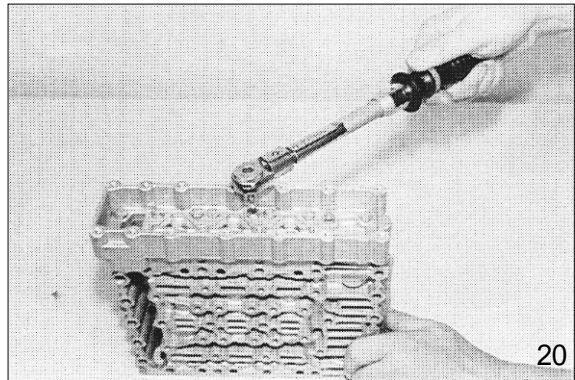

- (5) Introduce pressure regulators and fix by means of fixing plates and socket head screws.  
 Install fixing plate, with the claw showing downward.  
 Pay attention to the radial installation position of the pressure regulators, see figure.  
 · Torque limit : 0.56kgf · m(4.06lbf · ft)  
 Box spanner 5873 042 002

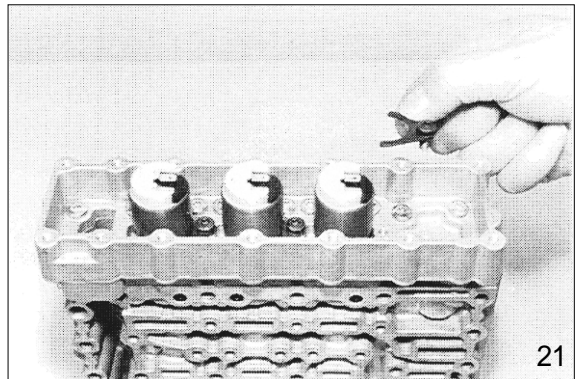

**Pre assemble opposite side**

- (6) Illustration on the right shows the following components.

- 1 Main pressure valve
- 2 Follow on slide
- 3 Vibration damper

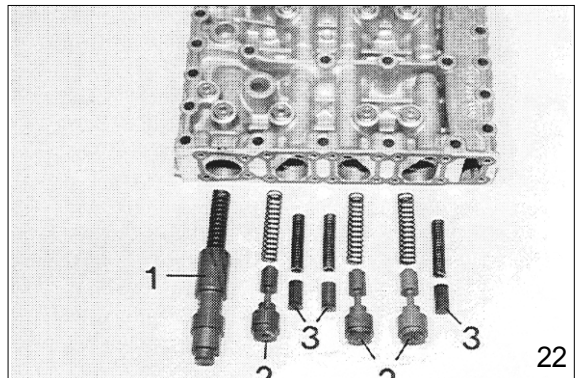

- (7) Install components according to figure (6).  
Preload compression springs of the follow-on slides and locate spool provisionally by means of cylindrical pins  $\varnothing 5.0\text{mm}$  (Assembly aid), see arrows.

Install two adjusting screws.

Assemble gasket (Arrow 1) and housing cover, and position them uniformly against shoulder, using adjusting screws.

Pay attention to the different housing covers—install the recess  $\varnothing 19\text{mm}$  (Arrow 2), facing the main pressure valve.

Now, fasten housing cover by means of socket head screws.

· Torque limit :  $0.56\text{kgf} \cdot \text{m}$  ( $4.06\text{lbf} \cdot \text{ft}$ )

Remove cylindrical pins (Assembly aid) again.

Adjusting screws                      5870 204 036

Box spanner                              5873 042 002

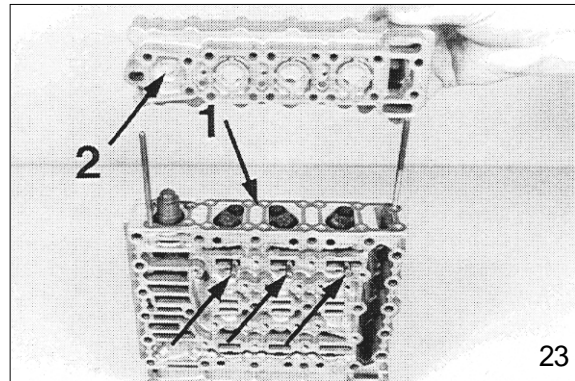

- (8) Introduce pressure regulators and fix by means of fixing plates and socket head screws.

Install fixing plates, with the claw showing downward.

Pay attention to the radial installation position of the pressure regulators, see figure.

· Torque limit :  $0.56\text{kgf} \cdot \text{m}$  ( $4.06\text{lbf} \cdot \text{ft}$ )

Box spanner                              5873 042 002

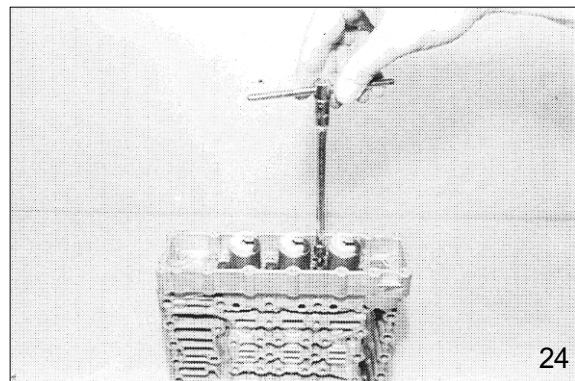

- (9) Introduce cable harness and connect pressure regulators (6EA).

Pay attention to the installation position of the cable harness, also markings (See figure(2), page 3-74).

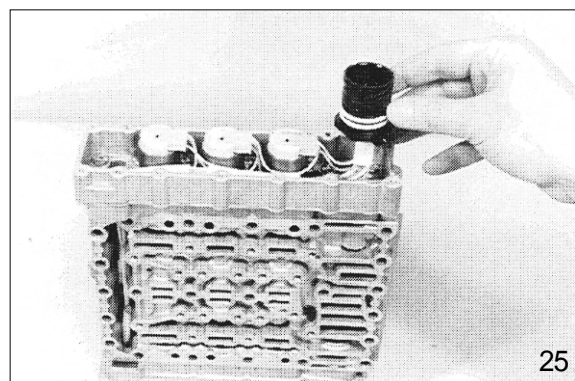

(10) Introduce female connector against shoulder, with the groove facing the guide nose of the cover.

Install gasket (Arrow) and fasten cover by means of socket head screws.

· Torque limit : 0.56kgf · m(4.06lbf · ft)

Box spanner 5873 042 002

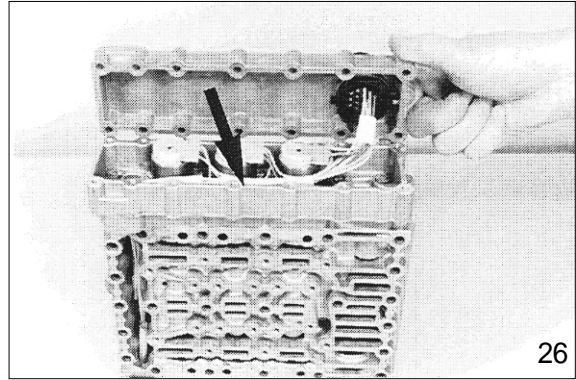

(11) Fix female connector by means of retaining clamp, see figure.

Install opposite cover.

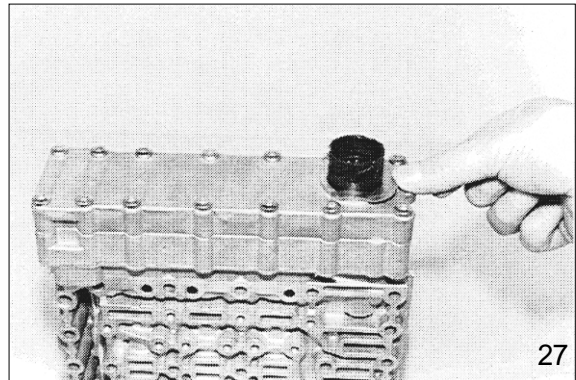

(12) Install two adjusting screws and mount gasket .

Pay attention to the different gaskets, see on the right figure and (15).

Adjusting screws 5870 204 063

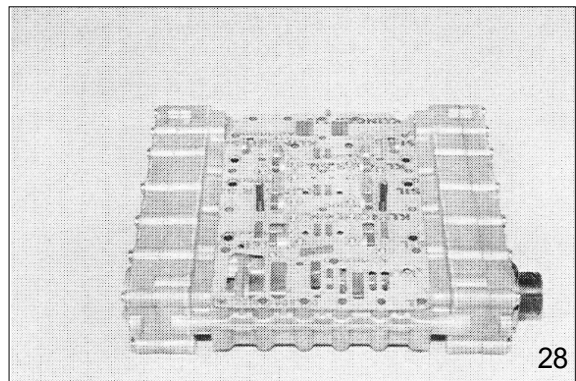

### Intermediate plate-Version with screens

(13) Insert screws(6EA) flush mounted into the bore of the intermediate plate, see arrow.

Pay attention to the installation position-screws are showing upward(Facing the duct plate).

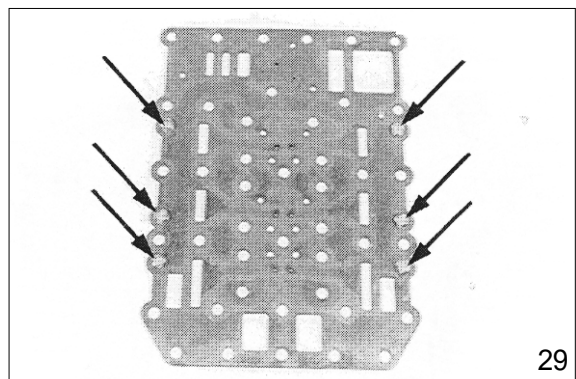

(14) Mount intermediate plate, with the screens showing upward.

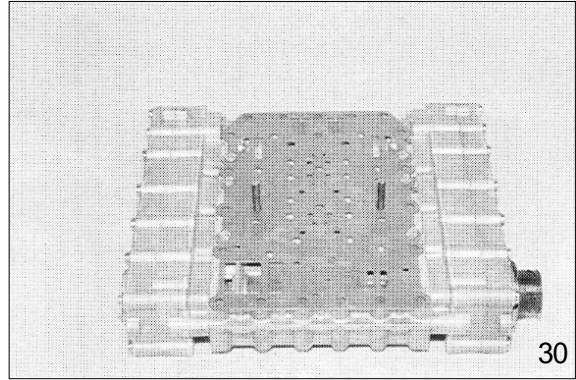

(15) Mount gasket

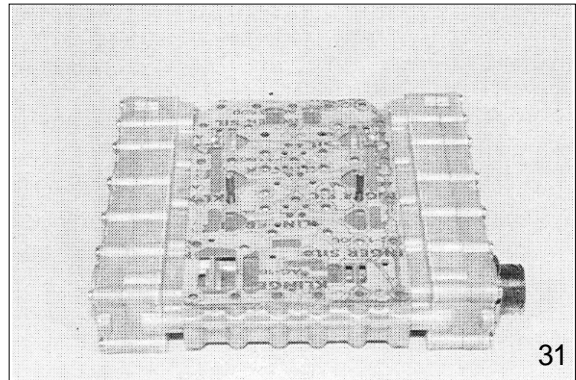

(16) Mount duct plate and fasten it uniformly by means of socket head screws.

· Torque limit : 0.97kgf · m(7.0lbf · ft)

Box spanner 5873 042 002

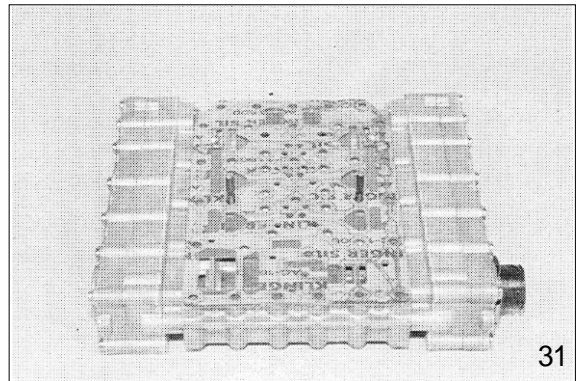

(17) Equip screw plug(8EA) with new O-rings and install them.

· Torque limit : 0.56kgf · m(4.06lbf · ft)

The installation of the hydraulic control unit is described, starting from page 3-131.

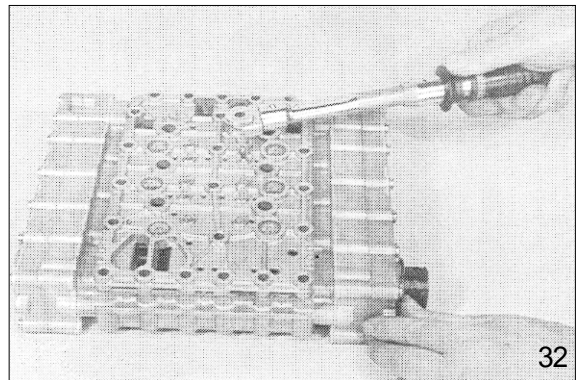

## 2. POWERSHIFT TRANSMISSION

Fasten transmission of the assembly car.

Assembly car	5870 350 000
Strips	5870 350 063
Support	5870 350 090

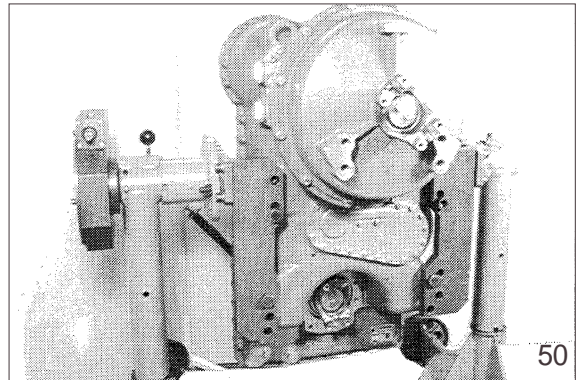

### 1) DISASSEMBLY

#### (1) Separate hydraulic control unit and duct plate from gearbox housing

Loosen two socket head screws and install adjusting screws.

Now, loosen remaining socket head screws and separate valve housing from duct plate.

Adjusting screws(M6)	5870 204 063
Box spanner	5873 042 002

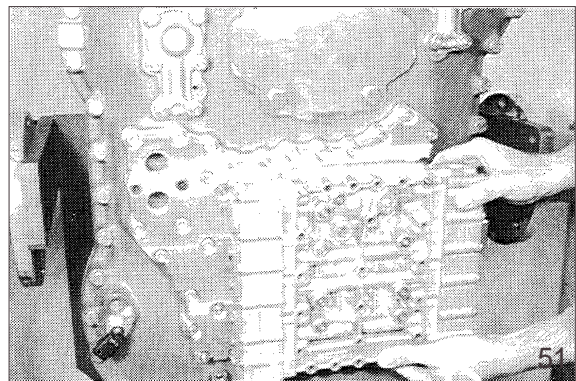

Remove both gaskets and intermediate plate.

Loosen socket head screws as well as hexagon nuts and separate duct plate from gearbox housing.

Now, remove gasket.

Box spanner	5873 042 004
-------------	--------------

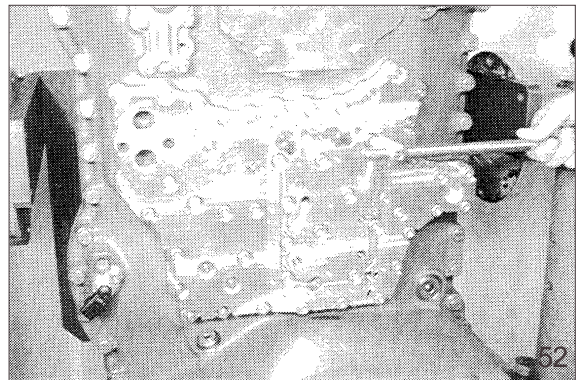

Pull converter safety valve out of the housing bore.

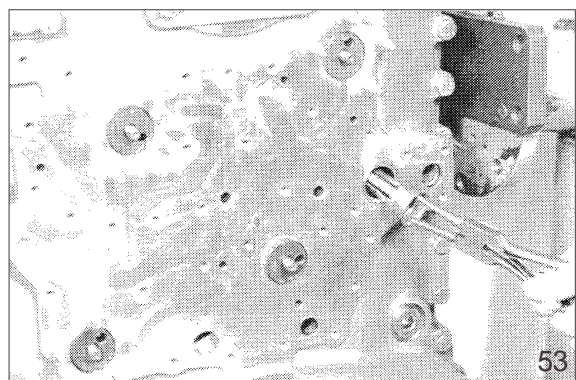

**(2) Converter**

Loosen hexagon head screws and separate diaphragm from the converter.

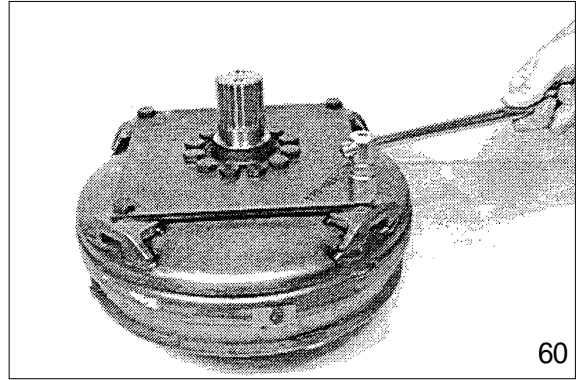

Loosen hexagon head screws and separate drive shaft from the diaphragm.

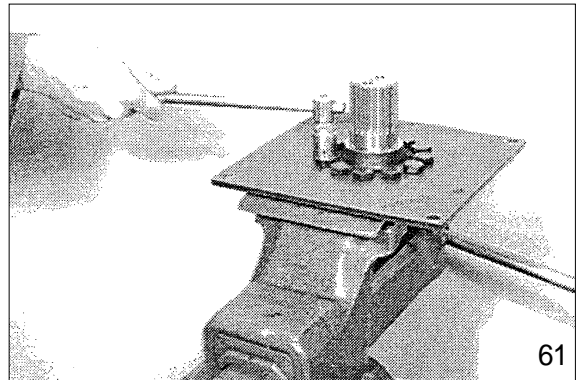

Remove inductive transmitter(Engine).

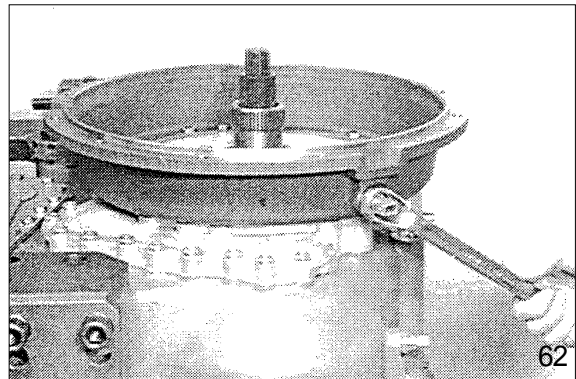

Loosen hexagon head screws and remove converter bell.

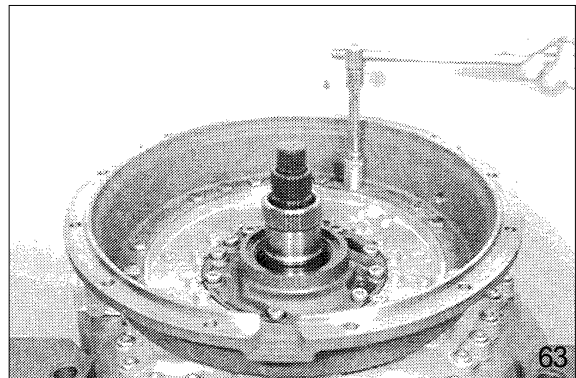

### (3) Hydraulic pump

Loosen socket head screws.

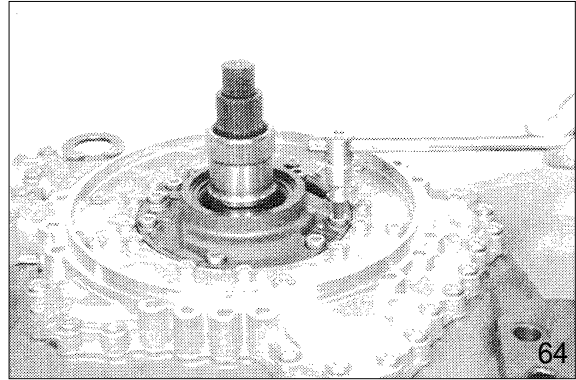

Apply separating device on the gear teeth runout of the stator shaft and pull pump(Compl.) by means of two leg puller carefully out of the housing bores.

Separating device            5870 300 024  
Two leg puller                5870 970 004

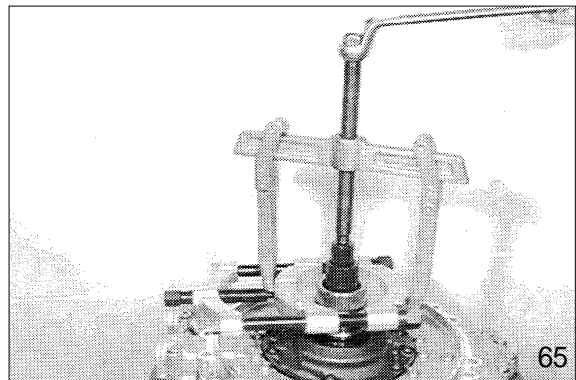

Separate hydraulic pump from stator shaft.

Separate control disk from pump.

If traces due to running in should be encountered in the pump housing or on the control disk, the complete pump has to be renewed.

Now, lay on control disk again and fix it by means of grooved pins(2EA).

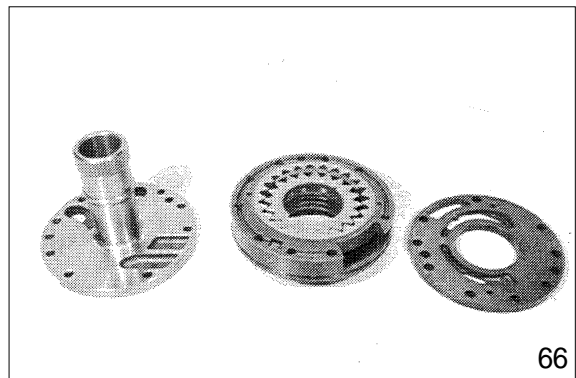

Loosen socket head screws as well as two hexagon head screws and remove oil feed housing.

Now, remove gasket.

Box spanner                    5873 024 004

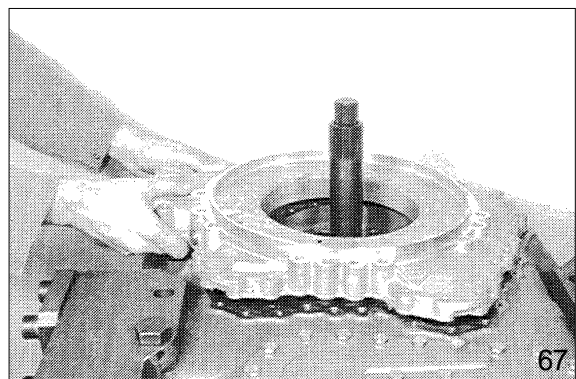

**(4) Converter back pressure valve**

Preload compression spring and remove lock plate.

Remove released components.

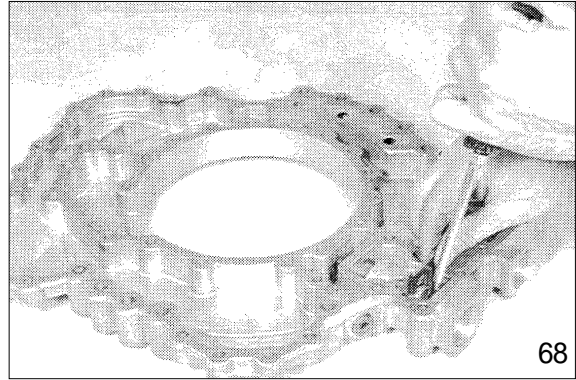

Loosen hexagon head screws.

Remove cover and gasket.

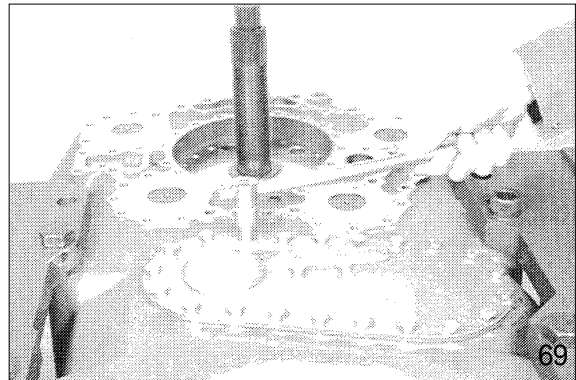

**(5) Remove output, input and clutches**

Remove lock plate, loosen hexagon head screws and pry converter side output flange off the shaft.

Now, pry shaft seal out of the housing bore.

Tilt transmission 180. and remove rear side output flange accordingly.

Pry bar 5870 345 065

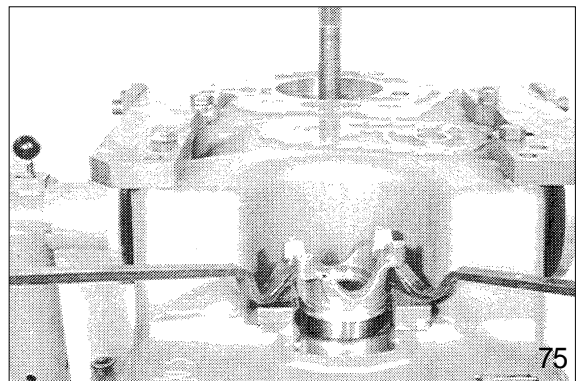

Remove speed sensor as well as both inductive transmitters(Arrows).

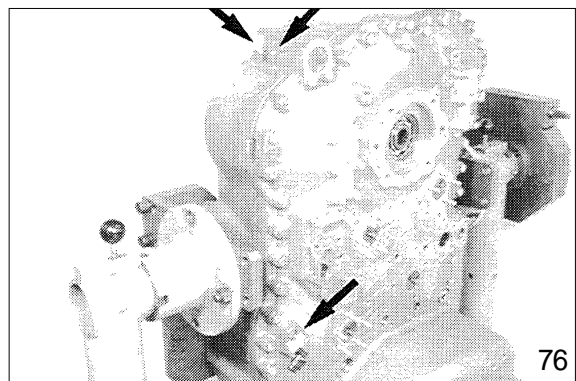

Loosen hexagon nuts and remove both covers(Arrows).

Loosen screw connection(Housing/  
Housing cover).

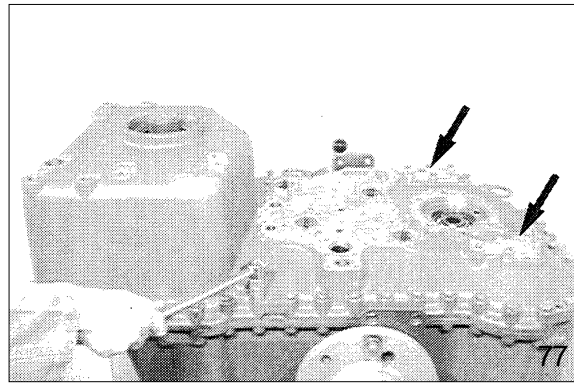

Drive both cylindrical pins out(Arrows).

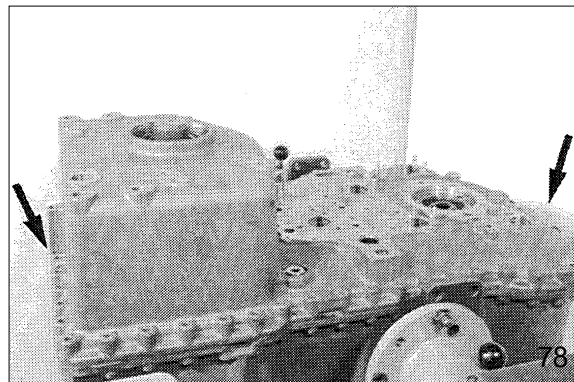

The following figures show the common removal of all clutches.

The removal of single clutches without use of the special tool(Handle 5870 260 010) is due to the installation conditions extremely difficult.

**Besides there is the danger of injuries.**

Locate all clutches by means of handles in the housing cover.

Install eye bolts and hang in the lifting device.

Handle(6 pieces needed) 5870 260 010

Eye bolt(M20, 2EA) 0636 804 003

Eye bolt(M16, 1EA) 0636 804 001

Puller device 5870 000 017

Lifting chain 5870 281 047

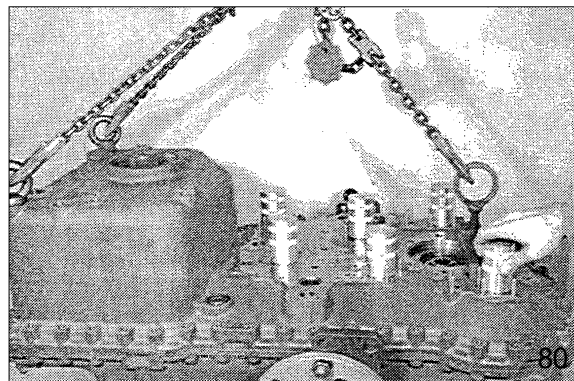

Separate housing cover along with clutches from the gearbox housing, using lifting device.

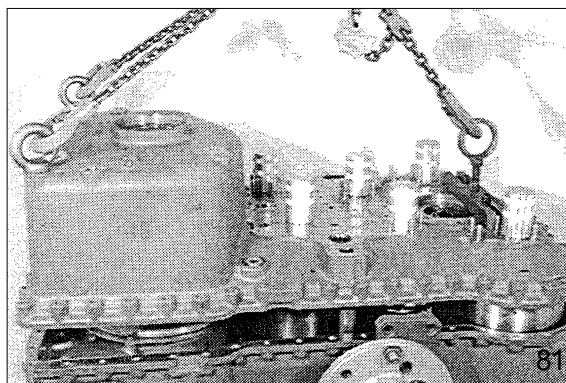

Fasten housing cover on the assembly car.

Assembly car 5870 350 000  
Clamping bracket 5870 350 089

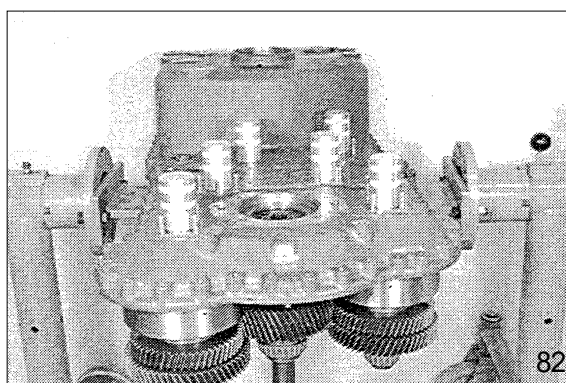

Loosen socket head screws and remove output shaft as well as the two oil collecting plate.

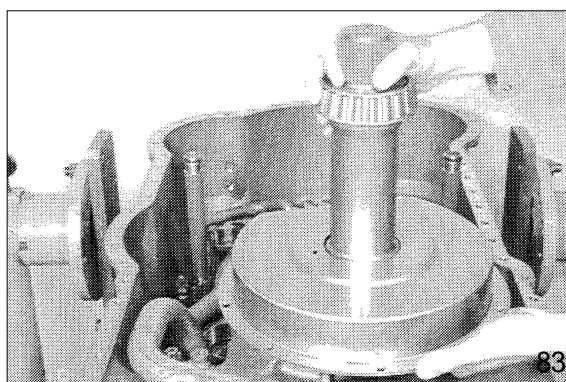

Pull off tapered roller bearing.  
Remove opposite tapered roller bearing accordingly.  
Grab sleeve 5873 002 038  
Basic set 5873 002 001

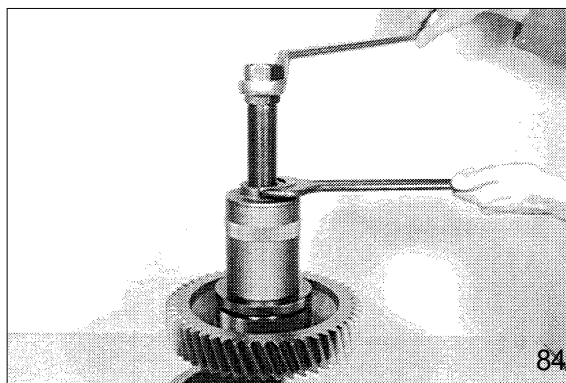

Tilt housing cover 180°.

Illustration on the right shows the arrangement of the single clutches and the input in the housing cover.

- AN Input
- KV Clutch-Forward
- KR Clutch-Reverse
- K1 Clutch-1st speed
- K2 Clutch-2nd speed
- K3 Clutch-3rd speed
- K4 Clutch-4th speed

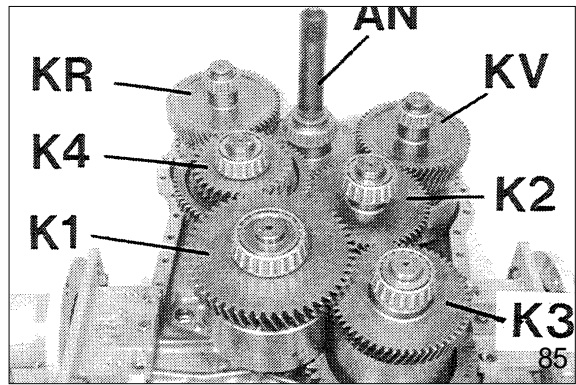

.Remove handles(See figure).

Handles 5870 260 010

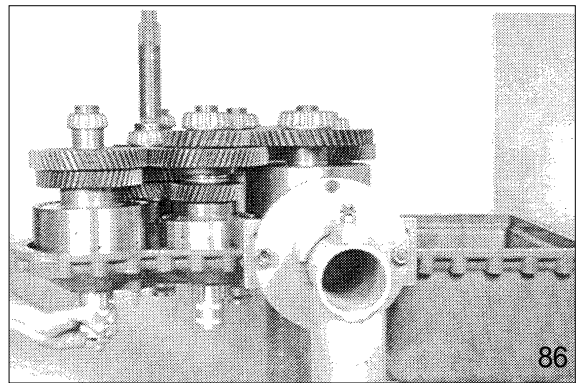

Lift clutch K4 a bit by means of pry bars and remove clutch K1.

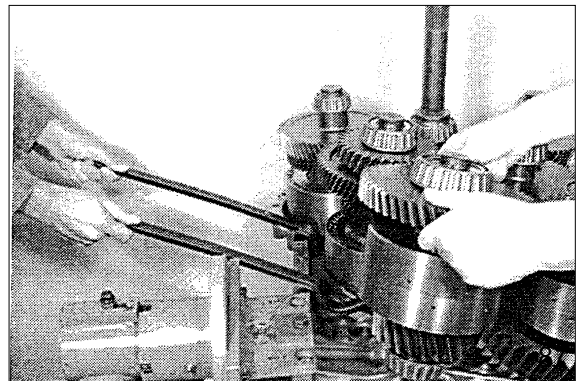

Remove clutch K2.

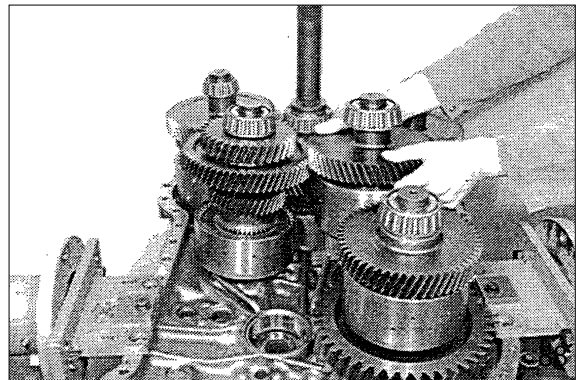

Remove clutch K3.

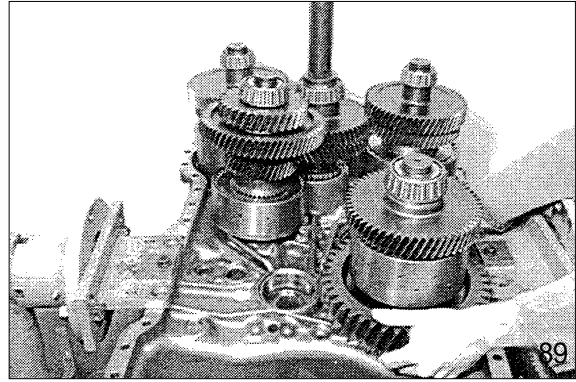

Lift clutch KV and KR by means of pry bars and remove clutch K4.

Pry bar

5870 345 065

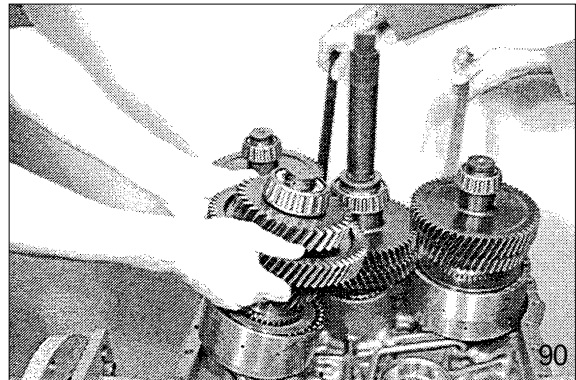

Lift clutch KV and clutch KR as well as input together out of the housing cover.  
Remove bearing outer races out of the housing bores.

If contrary to the recommendation the tapered roller bearings of the clutches as well as of the input and output will not be renewed, the allocation (Bearing inner races to bearing outer races) must at least be maintained.

Mark bearing inner race and bearing outer race accordingly to each other.

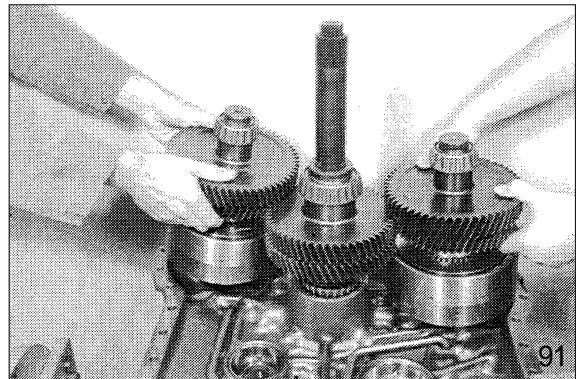

Tilt housing cover 90°.

Squeeze circlip out and separate pump shaft from housing cover.

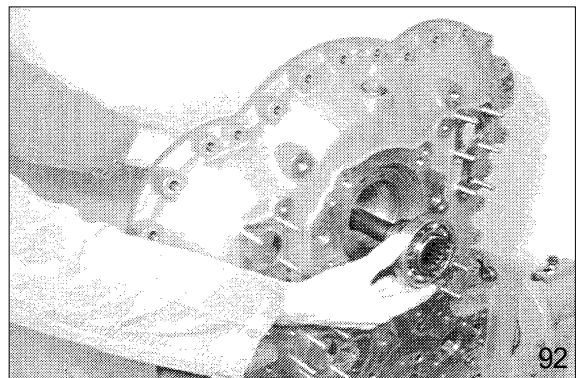

Squeeze rectangular ring out(Arrow) and press ball bearing from the shaft.

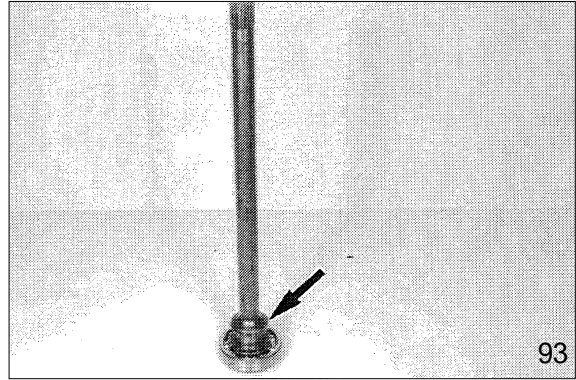

**(6) Disassemble clutch KV and KR**

The following figures show the disassembly of clutch KV.

The disassembly of clutch KR is similar.

Squeeze rectangular ring out(Arrow).

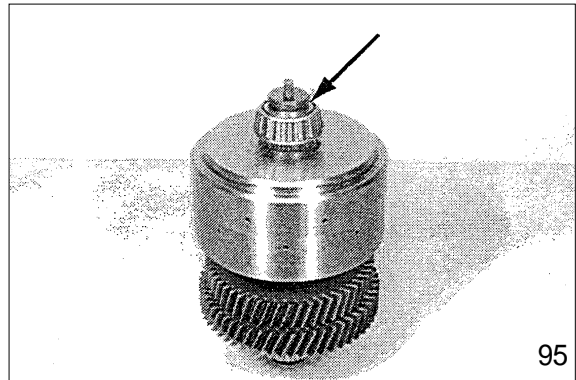

Pull tapered roller bearing from the shaft.  
Remove opposite tapered roller bearing accordingly.

Grab sleeve 5873 001 057

Grab sleeve 5873 001 059

Basic set 5873 001 000

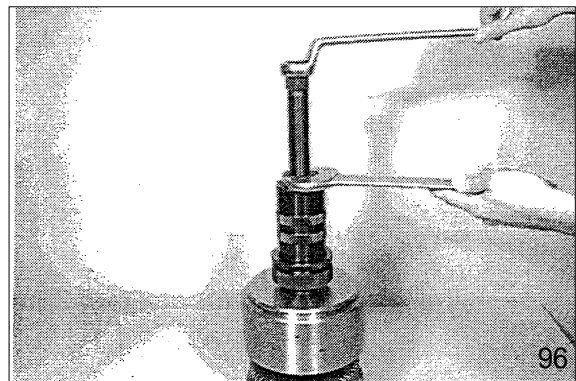

Squeeze circlip out.

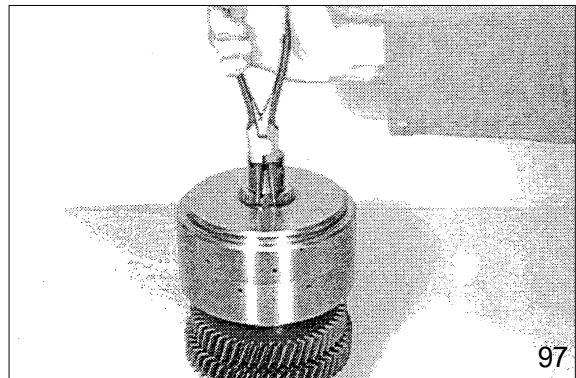

Separate plate carrier from the shaft.  
Three leg puller 5870 971 003

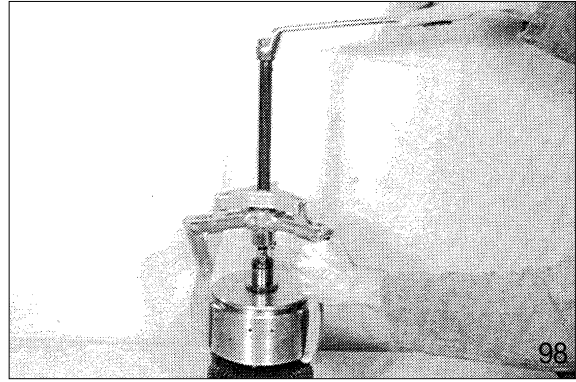

Squeeze snap ring out and remove plate pack.

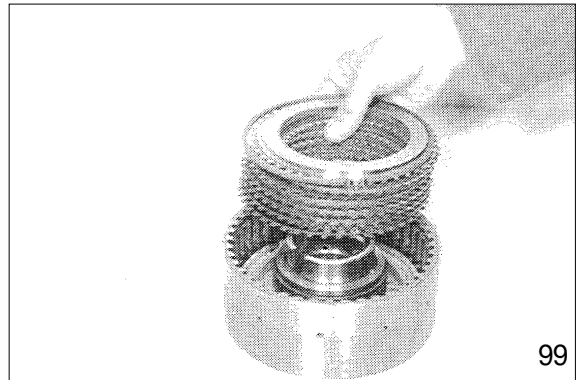

Preload compression spring, squeeze  
snap ring out and remove components.  
Assembly aid 5870 345 088

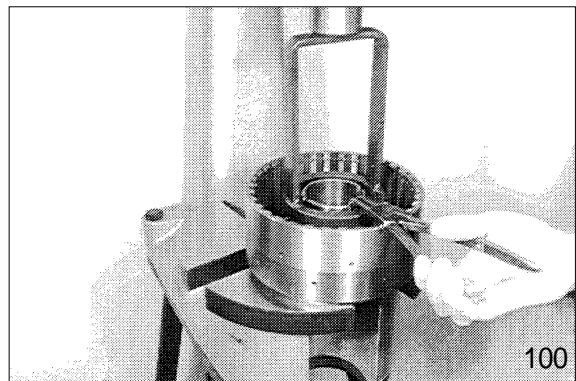

Lift piston by means of compressed air  
out of the cylinder bore and remove it.

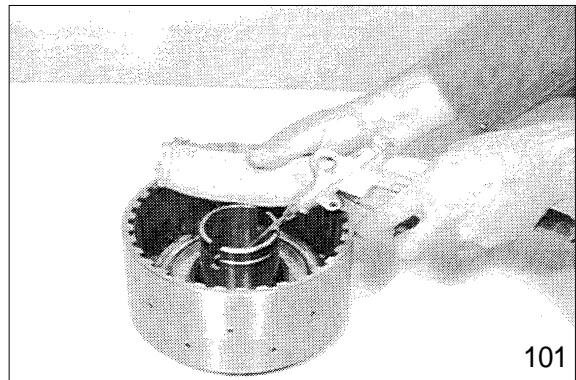

Remove both O-rings(Arrows).

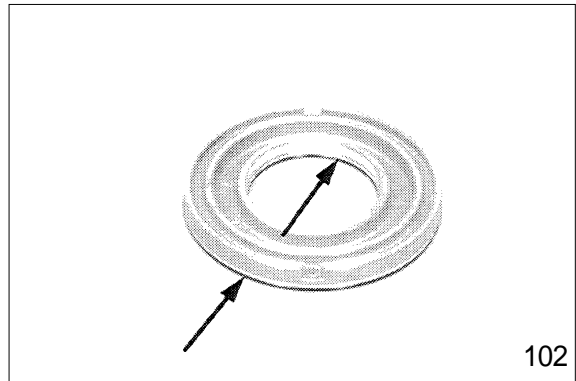

Lift idler gear a bit by means of pry bare.

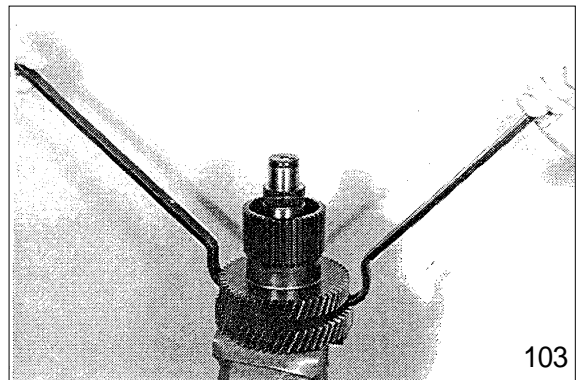

Apply puller and separate idler gear from the clutch shaft.

Pry bar 5870 345 065  
Puller 5870 971 003

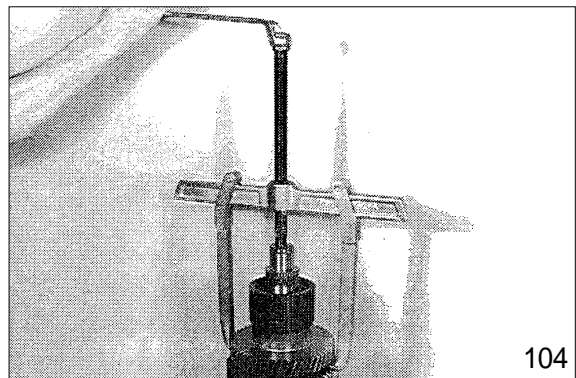

Squeeze circlip out and remove ball bearing.

The disassembly of clutch KR has to be carried out accordingly.

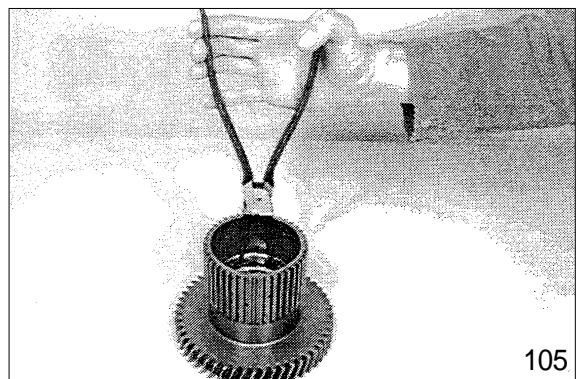

**(7) Disassemble clutch K1, K2 and K3**

The following figures show the disassembly of clutch K3.

The disassembly of the clutches K1 and K2 is similar.

Squeeze rectangular ring out.

Pull tapered roller bearing from the shaft.

Remove the opposite tapered roller bearing accordingly.

Grab sleeve(Bearing 33800) 5873 001 059

Grab sleeve(Bearing 39500) 5873 002 038

Basic set 5873 001 000

Basic set 5873 002 001

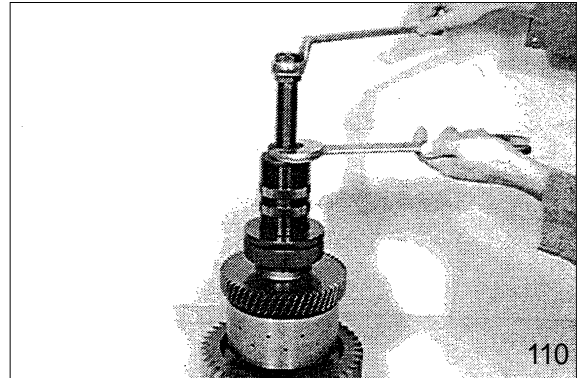

Remove running disk, axial needle cage and axial washer.

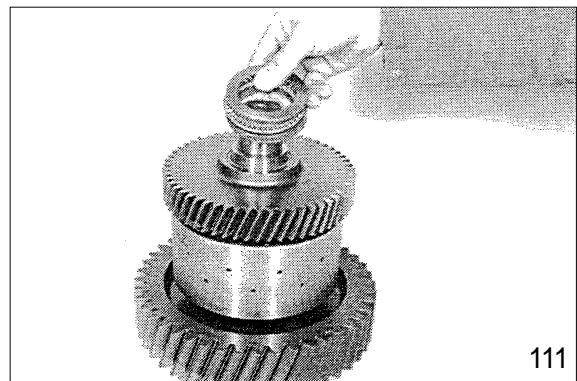

Remove idler gear.

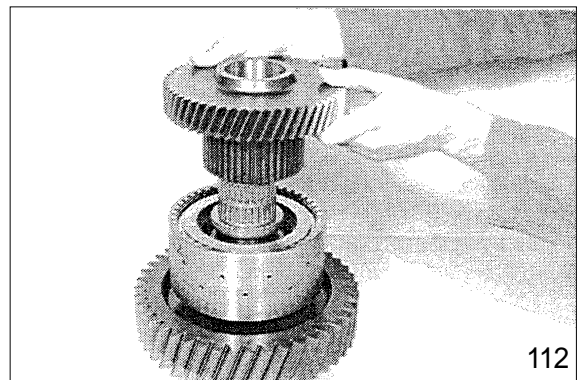

Remove both needle bearings as well as the axial bearing(Complete).

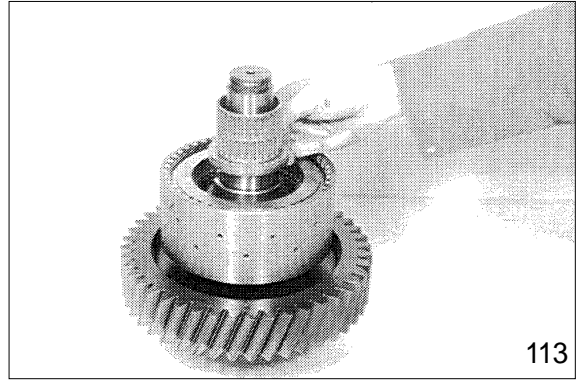

Squeeze snap ring out and remove plate pack.

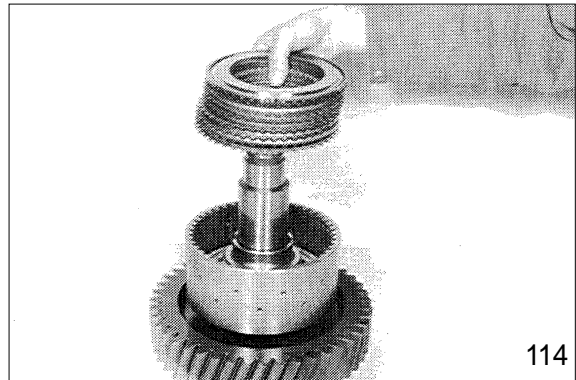

Preload cup-spring pack and squeeze snap ring out.  
Remove released components.  
Assembly aid 5870 345 088

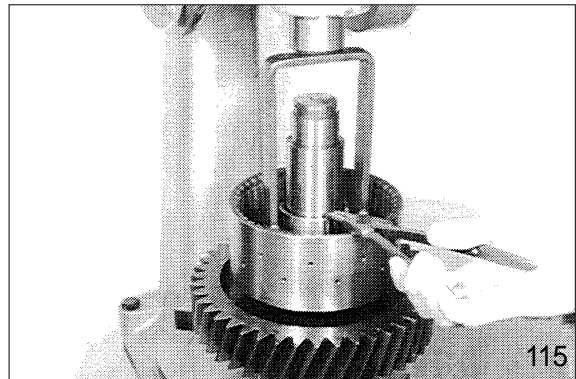

Squeeze circlip into the groove of the plate carrier.  
Apply puller on the circlip and pull plate carrier from the clutch shaft.  
Puller 5870 970 004  
Circlip 0630 502 053

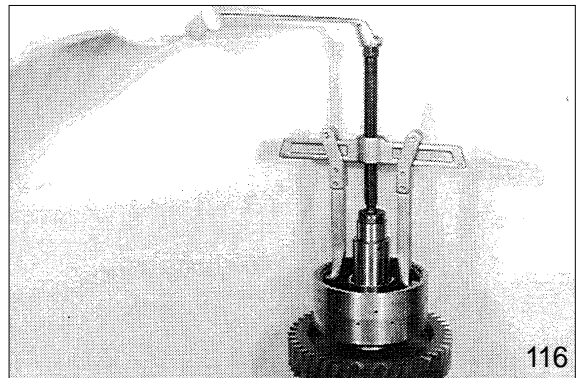

**(8) Disassemble clutch K4**

Squeeze rectangular ring out(Arrow).

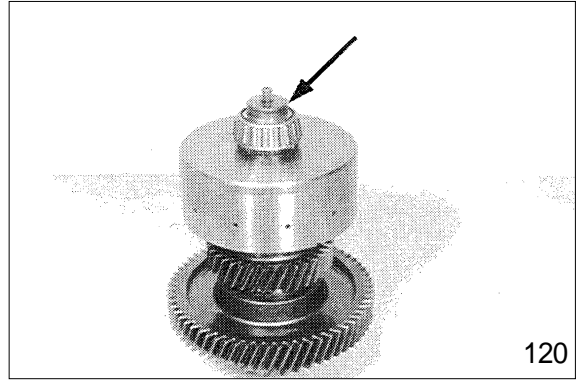

Pull tapered roller bearing from the shaft.  
Remove opposite tapered roller bearing accordingly.

Grab sleeve 5873 001 057

Grab sleeve 5873 001 059

Basic set 5873 001 000

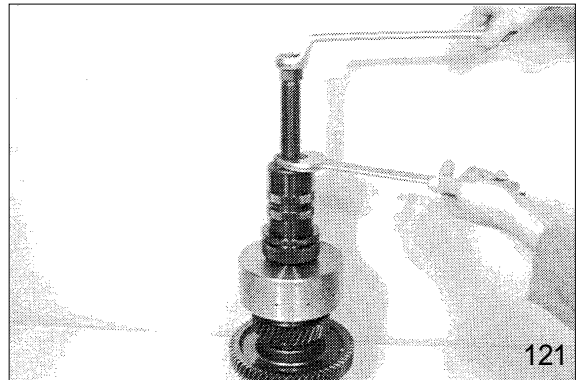

Squeeze circlip out and separate plate carrier from the shaft.

Three leg puller 5870 971 003

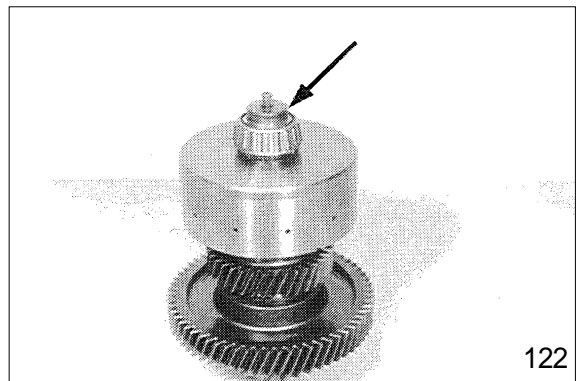

Squeeze snap ring out and remove plate pack.

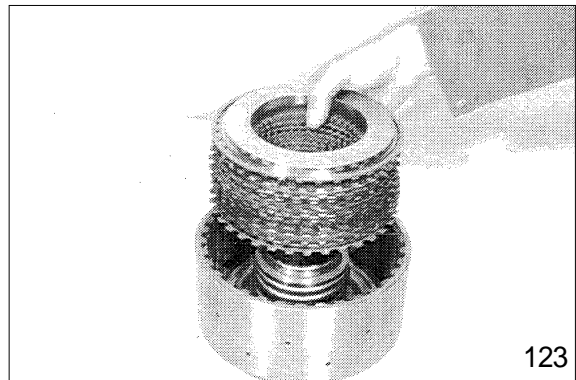

Preload cup-spring pack and squeeze snap ring out.  
Remove released components.  
Remove piston.  
Assembly aid 5870 345 008

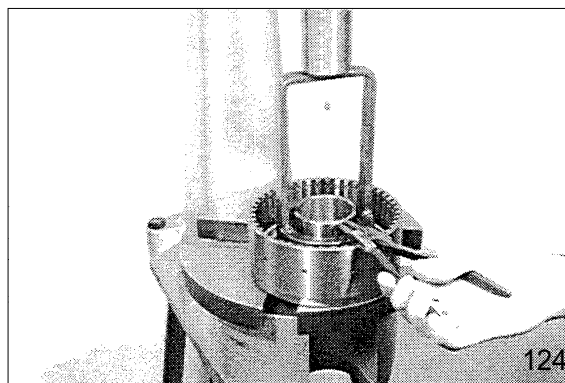

Lift piston by means of compressed air out of the cylinder bore and remove it.

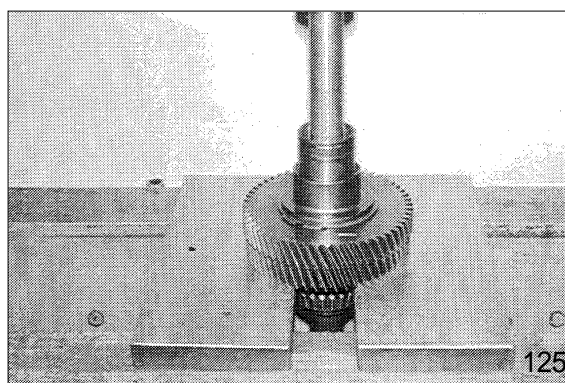

Take off the idler gear and remove release components.  
The separation of shaft and gear is not possible (Shrink fit).

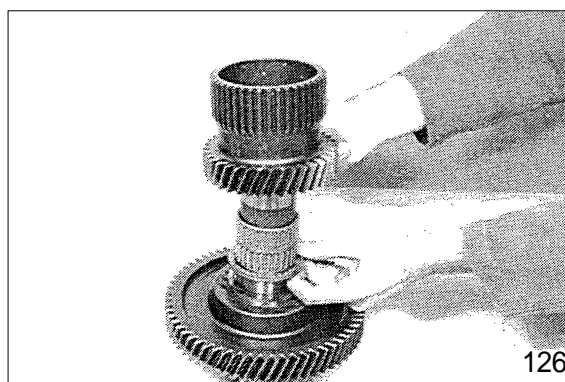

**(9) Disassemble drive shaft**

Squeeze rectangular ring out.

Pull off tapered roller bearing.

Remove opposite tapered roller bearing accordingly.

Grab sleeve 5873 002 045

Basic set 5873 002 001

Basic set 5873 002 006

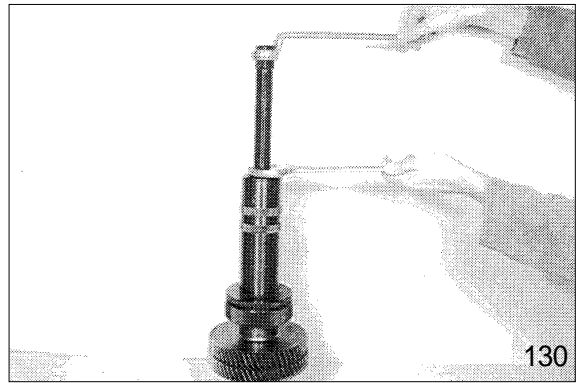

If necessary, press turbine shaft out of the drive shaft.

The turbine shaft is axially fixed with a snap ring which will be destroyed at the pressing out.

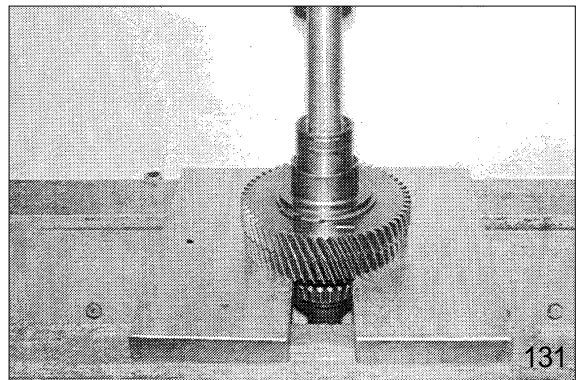

## 2) REASSEMBLY

### (1) Install oil tubes

To ensure the correct installation of the oil tubes, the use of the indicated special tool is imperative.

Insert suction pipe(1), pressure pipes(2) and pressure pipelubrication(3) into the housing bores.

Fasten suction and pressure pipes by means of socket head screws.

- Torque limit : 2.3kgf · m(17.0lbf · ft)

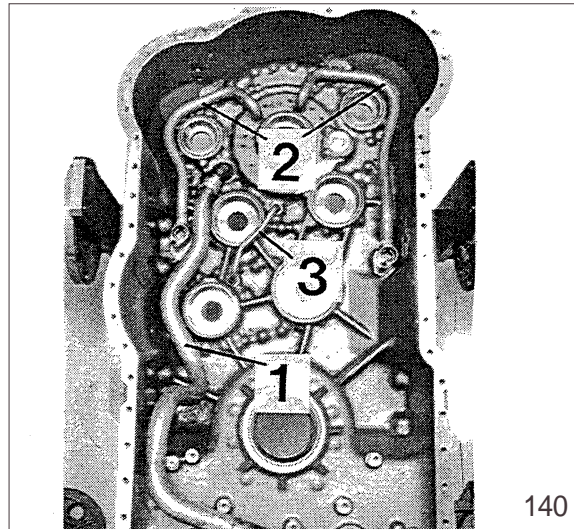

140

Tilt housing 180°.

Roll suction as well as pressure pipes(Arrows) into the housing bores, using special tool.

The pipe end must be maximally plane with the housing face.

If necessary, equalize projection of pipe.

Rolling tool 5870 600 003

Rolling tool 5870 600 005

Rolling tool 5870 600 007

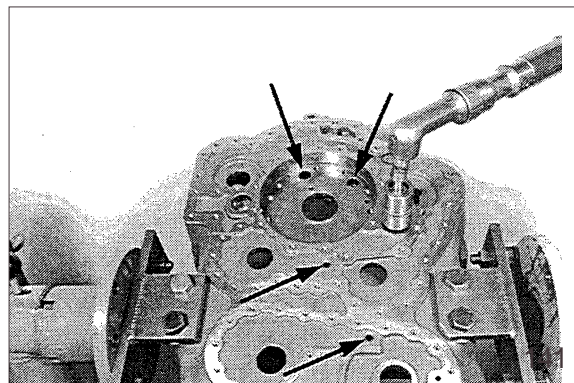

Insert O-rings(2EA/pipe) into the annular grooves of the two oil tubes and oil them.

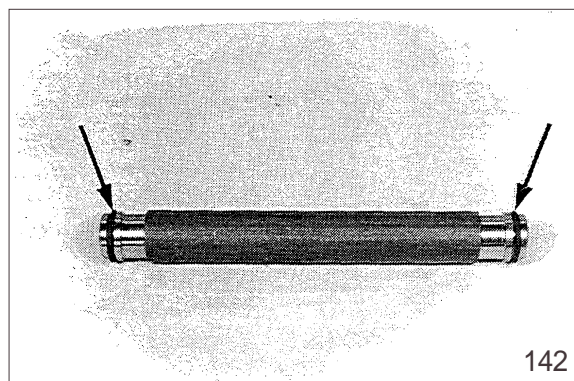

142

Assemble both oil tubes(Arrows) until contact is obtained.

Equip screw plug with new O-ring and install it.

- Torque limit : 14.3kgf · m(103lbf · ft)

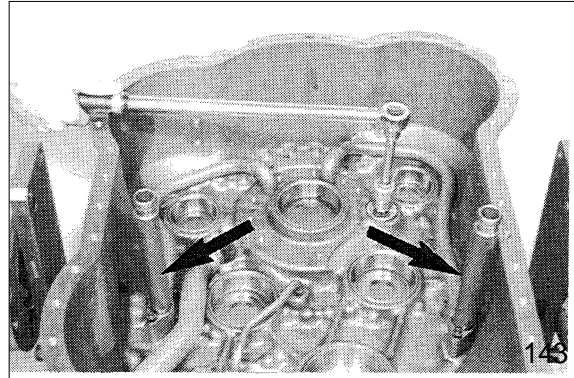

Insert both oil tubes(Arrows) into the housing cover, tilt housing cover 180, and roll oil tubes into the housing bores.

The tube end must be maximally plane with the housing face.

If necessary, equalize projection of the tube.

Rolling tool 5870 600 008

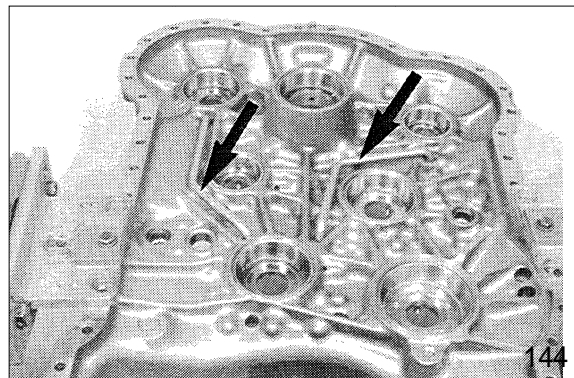

Mount studs(M8 x 25).

- Torque limit : 0.92kgf · m(6.64lbf · ft)

Wet screw in thread with loctite(Type No. 262).

Equip plugs(Arrows) with new O-rings and install them

- Torque limit(M16 x 1.5) : 4.1kgf · m  
(29.5lbf · ft)
- Torque limit(M18 x 1.5) : 5.1kgf · m  
(36.9lbf · ft)
- Torque limit(M26 x 1.5) : 8.2kgf · m  
(59.0lbf · ft)

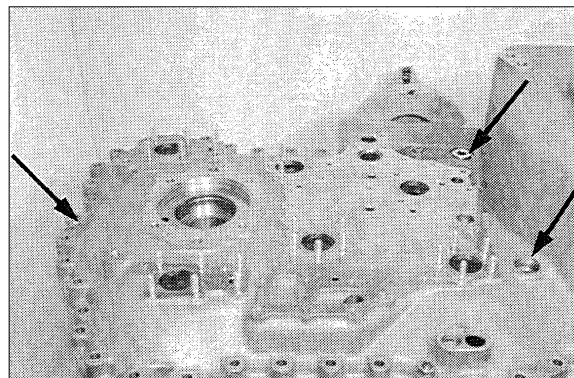

Insert sealing cover, with the recess showing upward.

Wet contact face with loctite(Type No. 262).

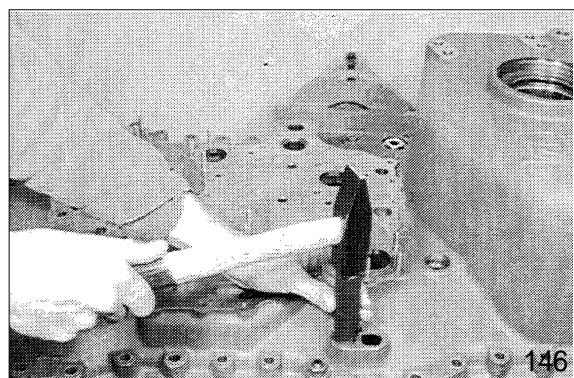

**(2) Reassemble clutch KV and KR**

The following figure show the reassembly of the clutch KV. The reassembly of the clutch KR has to be carried out accordingly.

**Preassemble plate carrier**

Check function of the purge valve.

Ball must not stick, if necessary, clean with compressed air.

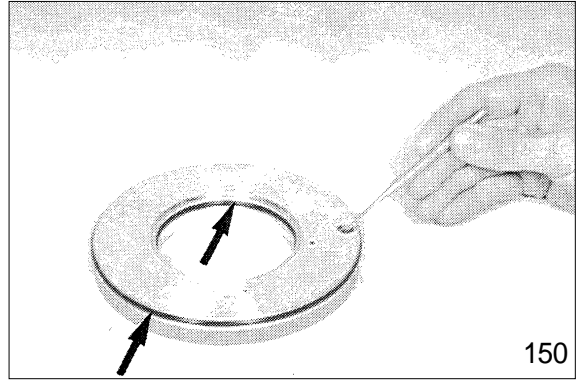

Insert both O-ring(Arrows) scrollfree into the grooves of the piston and oil.

Introduce piston until contact is obtained.

Pay attention to the installation position, see figure.

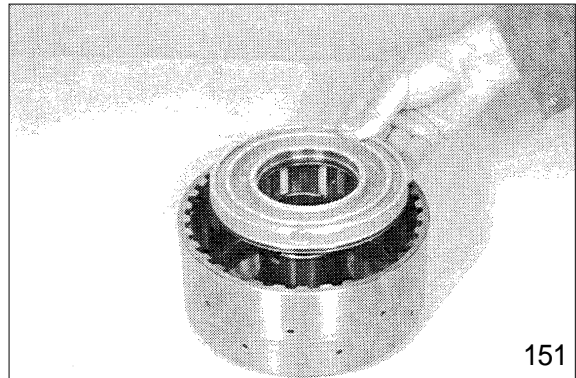

Install disk, compression spring and guide ring.

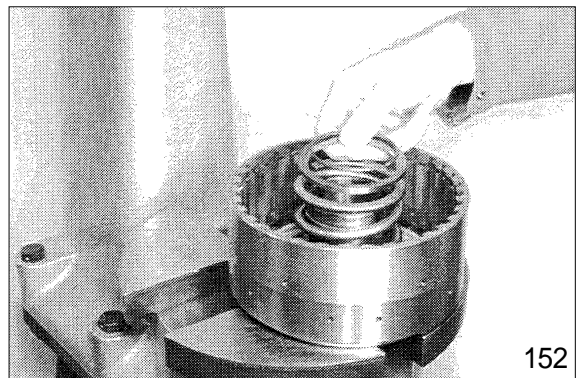

Preload compression spring and fix it by means of snap ring.

Assembly aid

5870 345 088

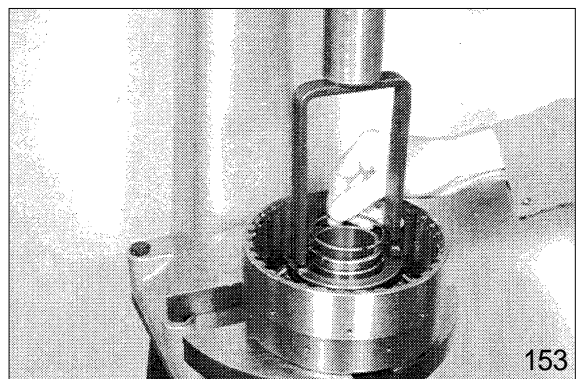

### Plate pack KV, KR

The plate arrangement respectively stacking of clutch KV and KR is identical.

The following draft shows the installation position of the components.

- 1 Plate carrier
- 2 Piston
- 3 Outer plate-one sided coated(1 piece)
- 4 Inner plates(10 pieces)
- 5 Outer plates-coated on both sides (10 pieces)
- 6 Snap ring(Optional s= 2.1~4.2mm)
- 7 End shim

Effective number of friction surfaces = 20

Install outer plate 3 with the uncoated side facing the piston.

Install on the end-shim side two outer and inner plates each.

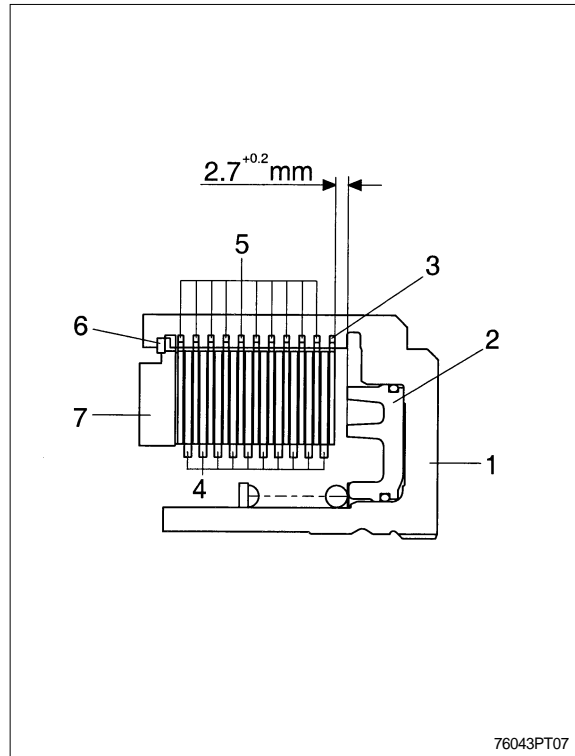

### Adjust plate clearance : $2.7+0.2$ mm

For the adjustment of the plate clearance are snap rings of different thickness available.

To ensure a faultless measuring result, install plates for the moment without oil.

Introduce plate pack according to the upper draft.

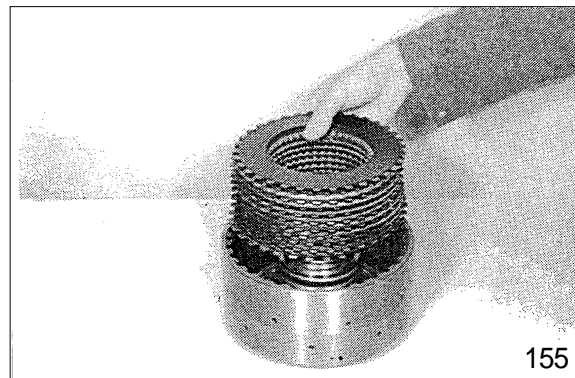

Lay on the end shim and squeeze the snap ring in(e.g. s=2.55mm)

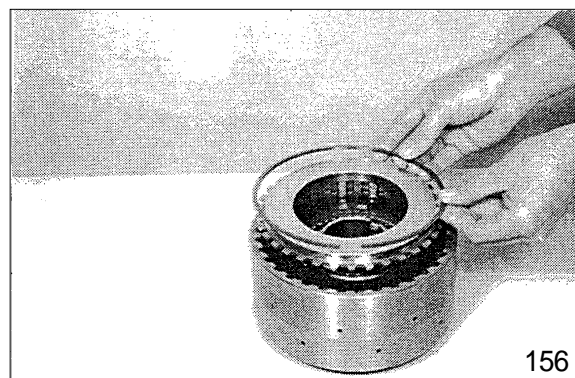

Press on end shim with about 100N (10kg), apply dial indicator and set it at zero.

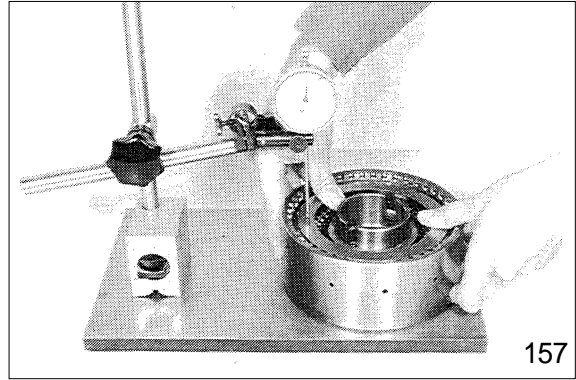

Now, push the end shim by means of screw driver against snap ring until contact is obtained(Upward) and read plate clearance on the dial indicator.

In case of a deviation from the required plate clearance, correct with corresponding snap ring(s=2.1~4.2mm).

After the adjustment of the plate clearance has been carried out, remove the plate pack, oil plates and install it again.

Use oil Dexron- D, /Mercon-M.

Magnetic stand 5870 200 055

Dial indicator 5870 200 057

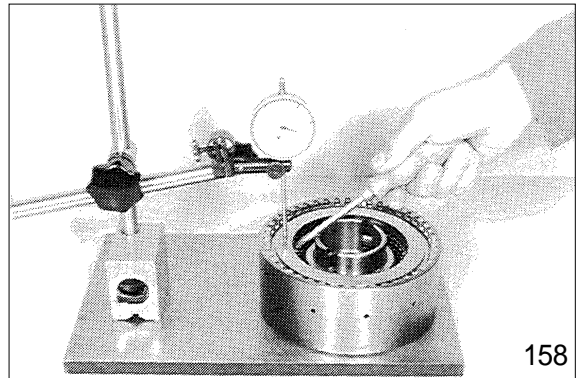

Introduce idler gear until all inner plates are accommodated.

This step makes the later assembly of the idler gear easier.

Now, remove the idler gear again.

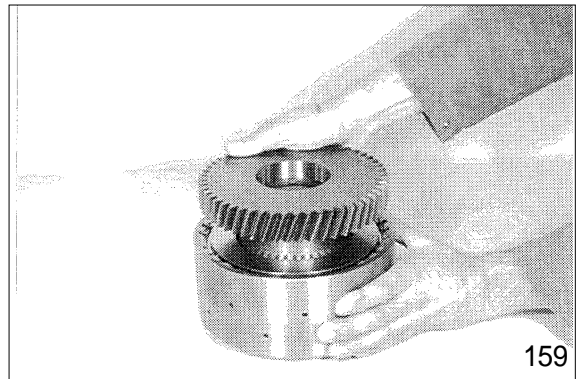

Mount stud(Arrow).  
Wet screw-in thread with loctite(Type No.241).  
· Torque limit(M10) : 1.7kgf · m(12.5lbf · ft)

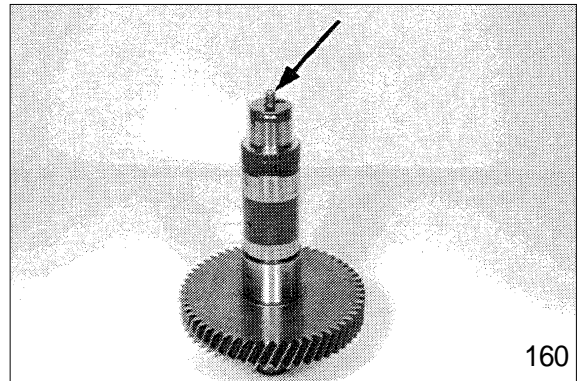

Insert ball bearing until contact is obtained and fix by means of circlip.

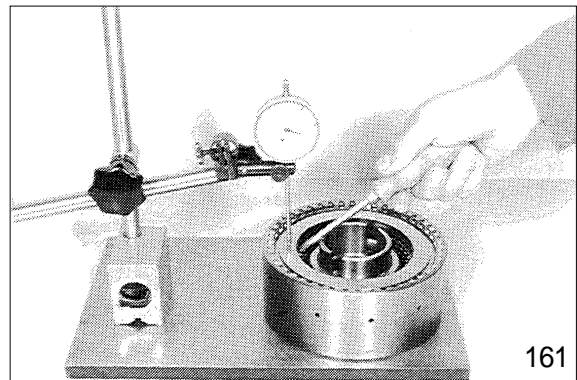

Assemble needle bearing.

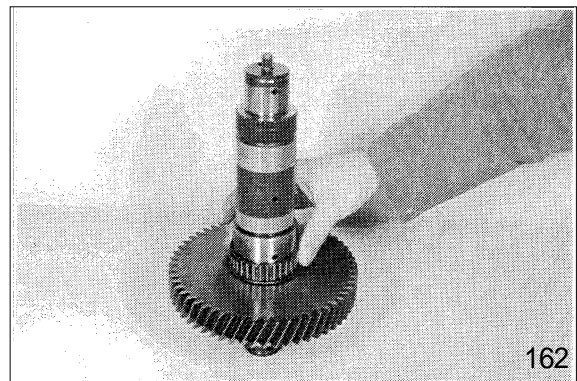

Press idler gear against shoulder.  
Support it on the bearing inner race.

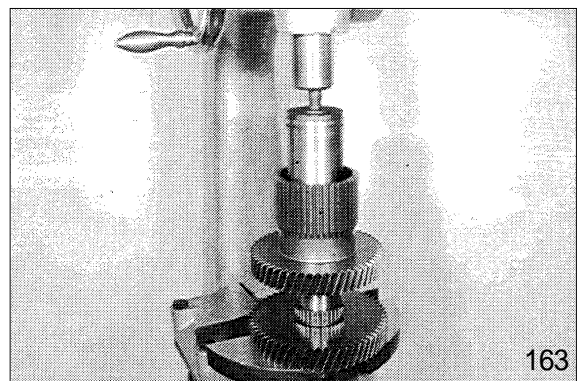

Heat inner diameter of plate carrier (About 120°C).

Hot air blower 220V            5870 221 500

Hot air blower 110V        5870 221 501

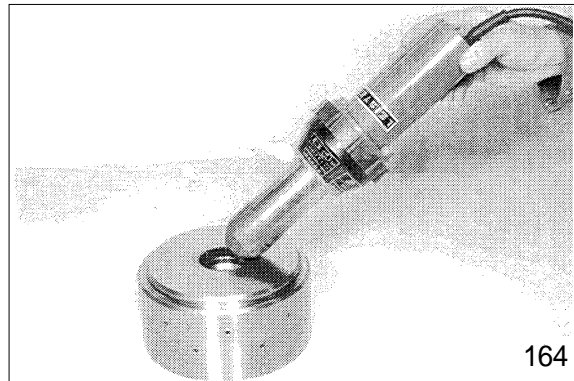

Assemble preassembled plate carrier until contact is obtained.

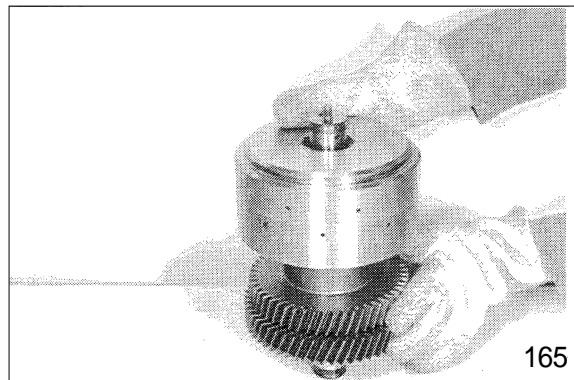

Locate plate carrier axially by means of circlip.

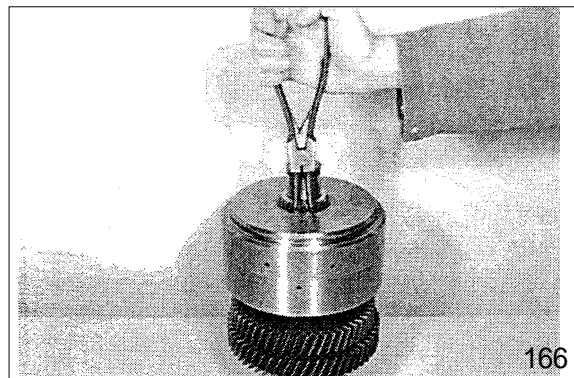

Check function of clutch by means of compressed air.

At correctly installed components, the closing resp. opening of the clutch is clear audible.

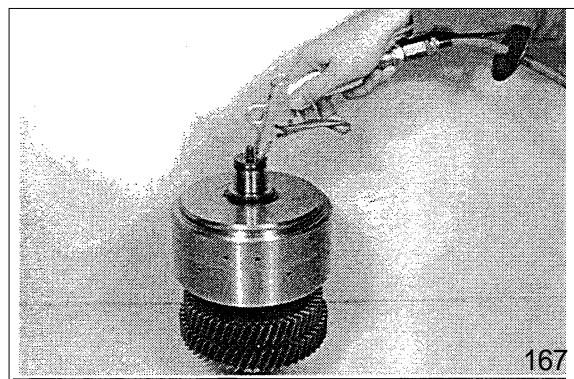

Press tapered roller bearing against shoulder.  
Install opposite tapered roller bearing accordingly.

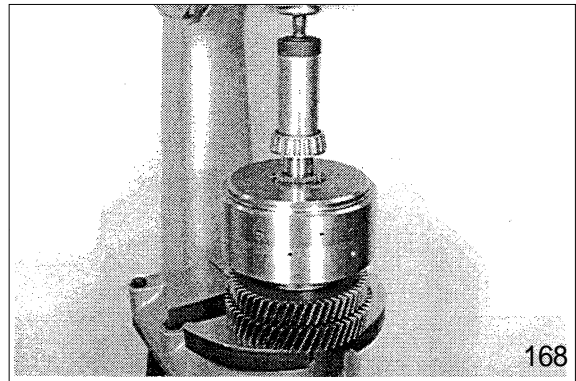

Squeeze rectangular rings in(Arrow) and let them snap in.

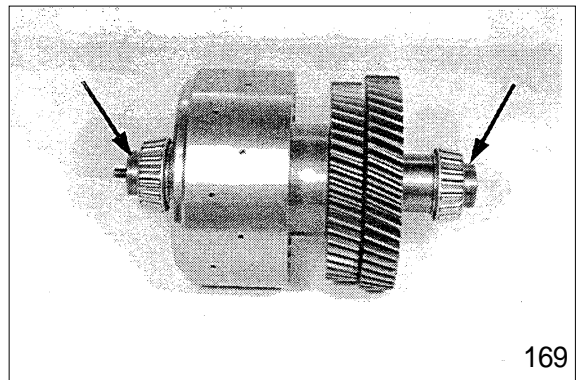

**(3) Reassemble clutch K1, K2 and K3**

The following figures show the reassembly of clutch K3.

The reassembly of the clutches K1 and K2 has to be carried out accordingly.

Install stud(Arrow).

Wet screw in thread with loctite(Type No. 241).

- Torque limit(M10) : 1.7kgf · m(12.5lbf · ft)

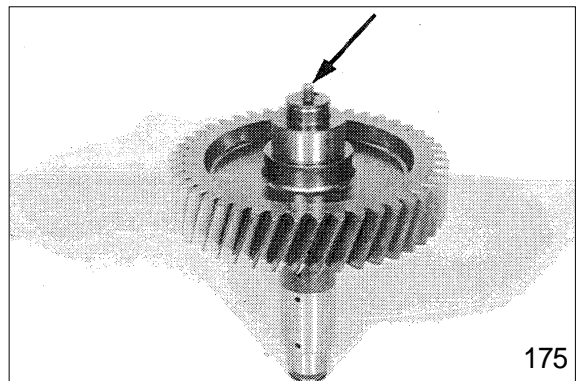

Heat inner diameter of plate carrier.

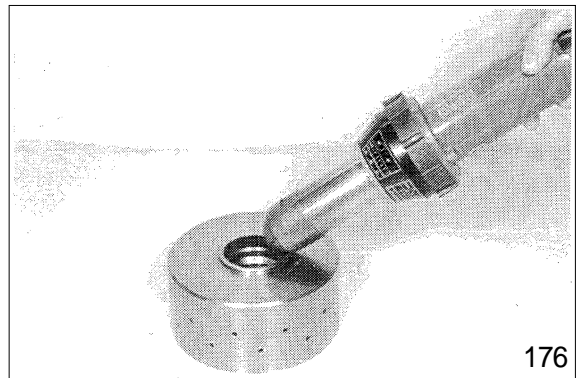

Assemble plate carrier until contact is obtained.

Hot air blower 220V      5870 221 500

Hot air blower 110V      5870 221 501

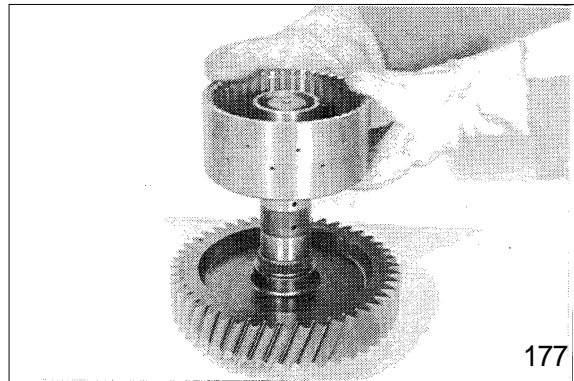

.Check function of the purge valve

Ball must not stick, if necessary clean with compressed air.

Insert both O-rings(Arrows) scrollfree into the grooves of the piston and oil.

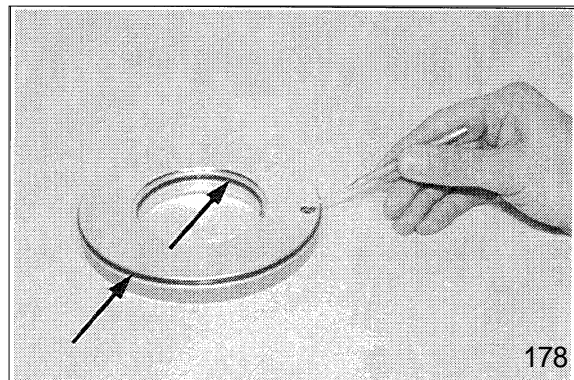

Introduce piston until contact is obtained.

Pay attention to the installation position, see figure.

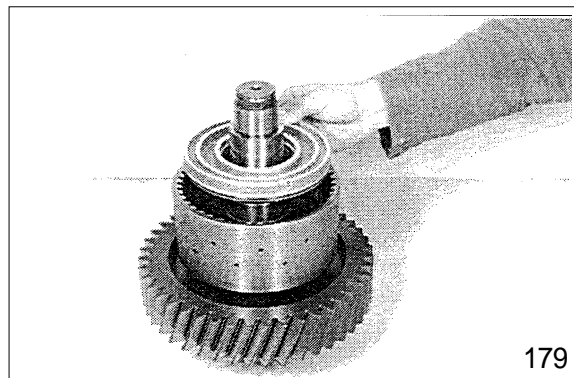

Lay on cup spring pack and guide ring.

Pay attention to the stacking of the cup springs, see the next draft.

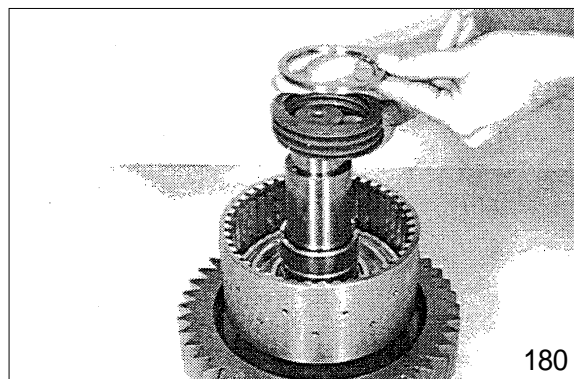

Preload cup spring pack and fix it by means of snap ring.

Assembly aid

5870 345 088

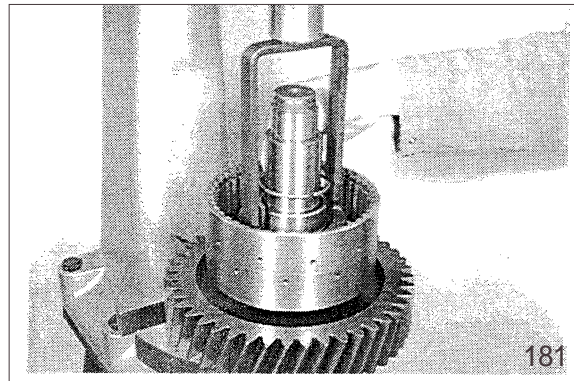

The plate arrangement of clutch K1 is identical with clutch K2 and K3.

In this connection see the following drafts.

### Plate pack K1

- 1 Plate carrier
- 2 Piston
- 3 Outer plate-one side coated(1 piece)
- 4 Inner plates(9 pieces)
- 5 Outer plates-on both sides coated (9 pieces)
- 6 Snap ring(Optional  $s=2.1\sim 4.2\text{mm}$ )
- 7 End shim

Effective number of friction surfaces = 18

Install outer plate 3 with the uncoated side facing the piston.

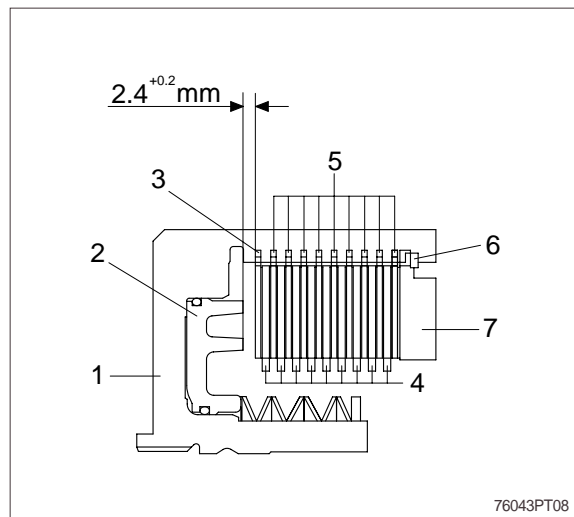

### Plate pack K2 and K3

- 1 Plate carrier
- 2 Piston
- 3 Outer plate-one side coated(1 piece)
- 4 Inner plates(7 pieces)
- 5 Outer plates-on both side coated (7 pieces)
- 6 Snap ring(Optional  $s= 2.1\sim 4.2\text{mm}$ )
- 7 End shim

Effective number of friction surfaces = 14

Install outer plate 3 with the uncoated side facing the piston.

Install on the end-shim two outer and inner plates each.

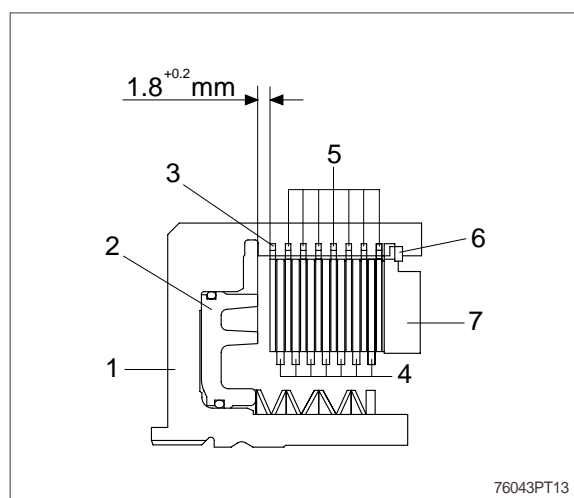

### Adjust plate clearance

Plate clearance clutch K1  $2.4^{+0.2}\text{mm}$

Plate clearance clutch K2 and K3  
 $1.8^{+0.2}\text{mm}$

For the adjustment of the plate clearance are snap rings with different thickness available.

To ensure a faultless measuring result, install the plates for the moment without oil.

Introduce plate pack according to drafts / page 3-107.

Lay on the end shim and squeeze circlip in (e.g.  $s=3.1\text{mm}$ ).

Press on the end shim with about 100N (10kg), apply dial indicator and set it at zero.

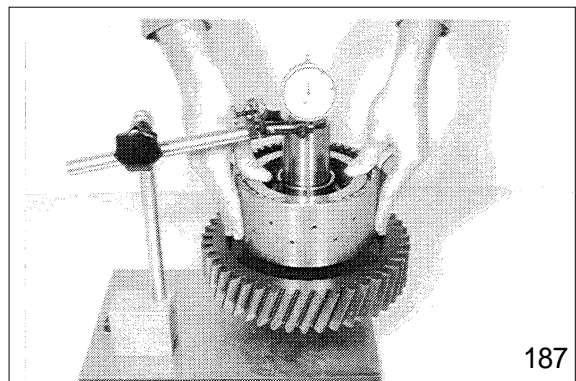
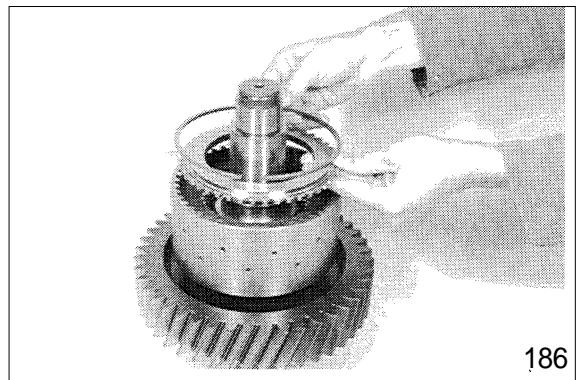
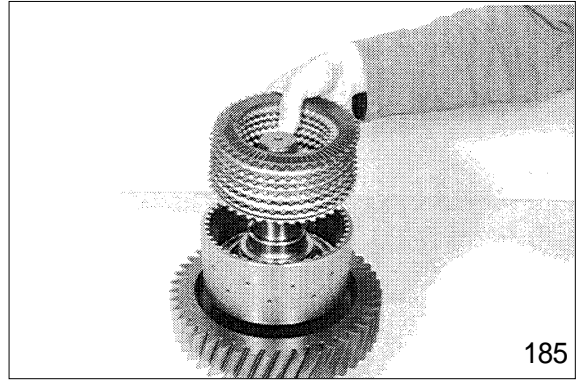

Now, push the end shim by means of screw driver against snap ring until contacts is obtained(Upward) and read plate clearance on the dial indicator.  
 In case of a deviation from the required plate clearance, correct with corresponding snap ring(s=2.1~4.2mm).  
 After the adjustment of the plate clearance has been carried out, remove the plate pack, oil plates and install it again.

Use oil Dexron- D, /Mercon-M.

Magnetic stand 5870 200 055

Dial indicator 5870 200 057

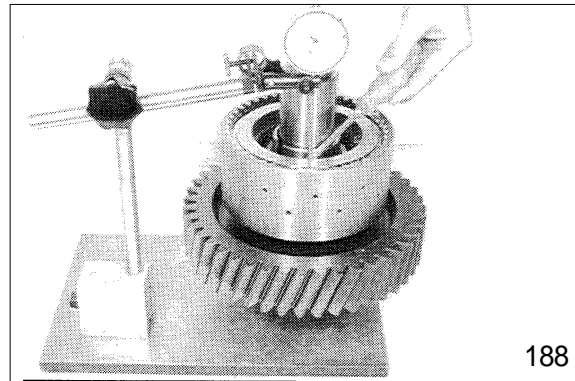

Assemble running disk 1(55 x 78 x 5), axial needle cage 2 and axial washer 3 (55 x 78 x 1).

Install running disk 1, with the chamber facing the axial needle cage.

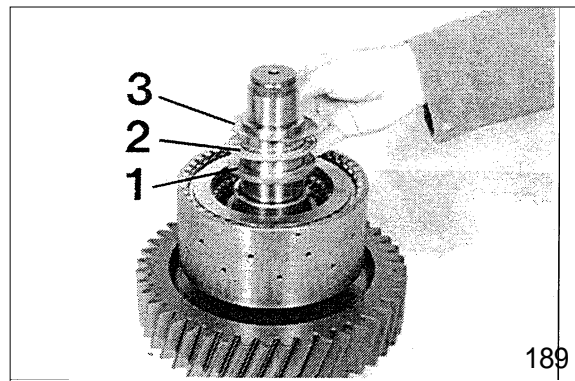

Assemble both needle bearings.

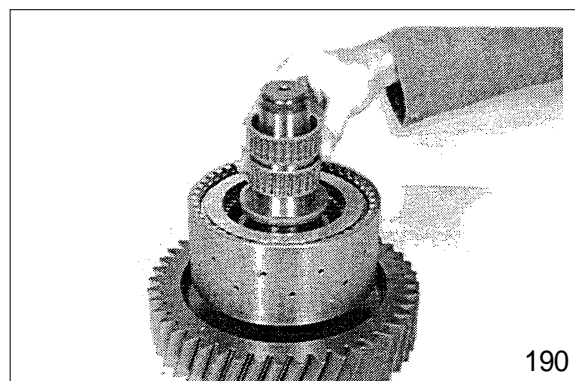

Introduce idler gear until all inner plates are accommodated.

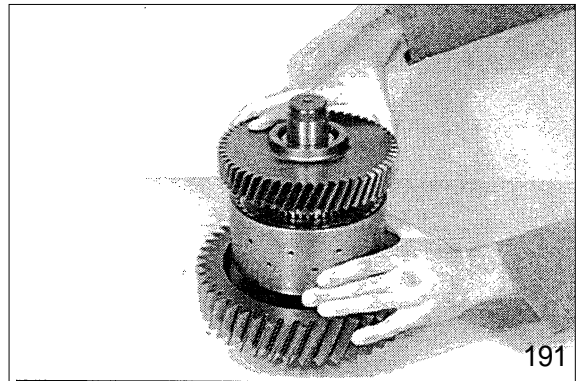

Assemble axial washer 3(55 × 78 × 1), axial needle cage 2 and running disk 1 (55 × 78 × 5).

Install running disk 1, with the chamfer facing the axle needle cage.

Only if the running disk in overlapping with the shaft collar is ensured that all inner plates are accommodated.

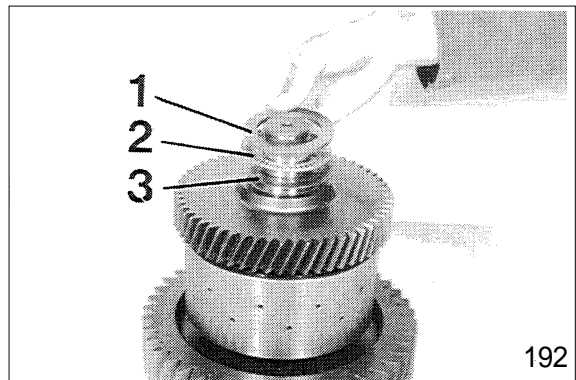

Press tapered roller bearing against shoulder.

Press opposite tapered roller bearing against shoulder.

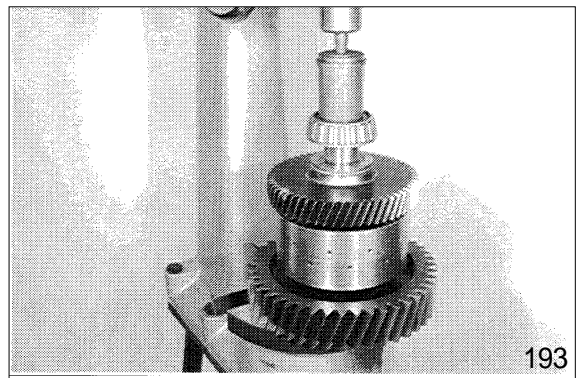

Check function of the clutch by means of compressed air.

At correctly installed components, the closing respectively opening of the clutch is clearly audible.

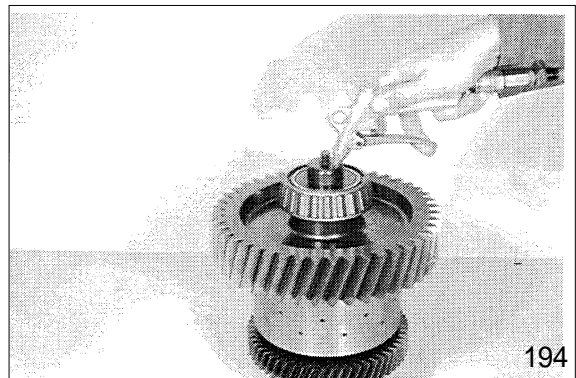

Squeeze rectangular ring in(Arrow) and let it snap in.  
Install opposite rectangular ring accordingly.

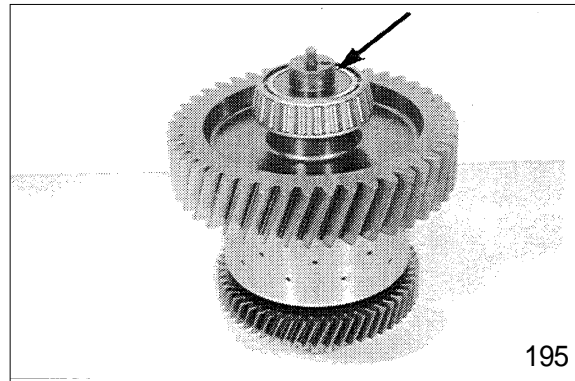

#### (4) Reassemble clutch K4

Undercool shaft(About  $-80^{\circ}\text{C}$ ), heat gear (About  $+120^{\circ}\text{C}$ ) and assemble it until contact is obtained.

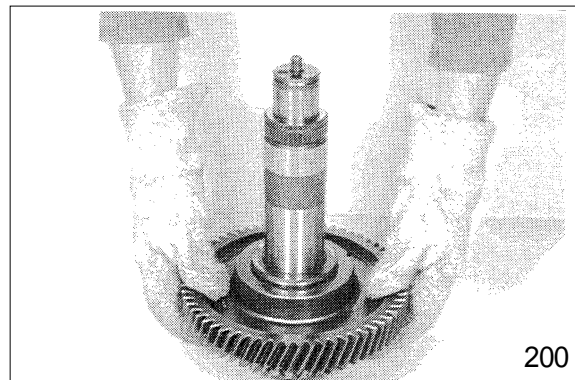

Fix gear axially by means of circlip.  
Set of external pliers 5870 900 015

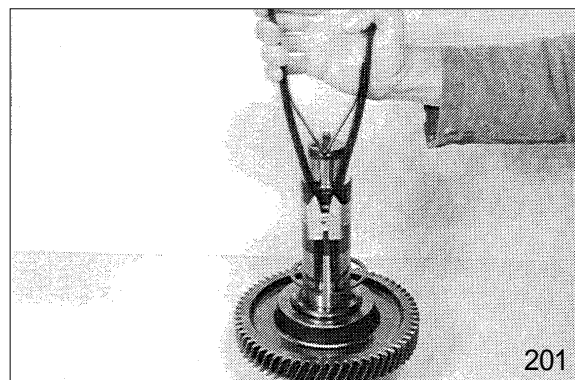

Install stud(Arrow).  
Wet screw-in thread with loctite(Type No. 241).  
• Torque limit(M10) :  $1.7\text{kgf} \cdot \text{m}$  ( $12.5\text{bf} \cdot \text{ft}$ )

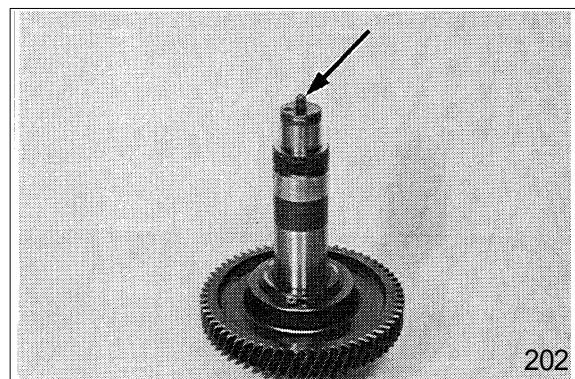

Check function of the purge valve.  
Ball must not stick, if necessary clean  
with compressed air.  
Insert both O-ring(Arrow) scrollfree into  
the grooves of the piston and oil them.

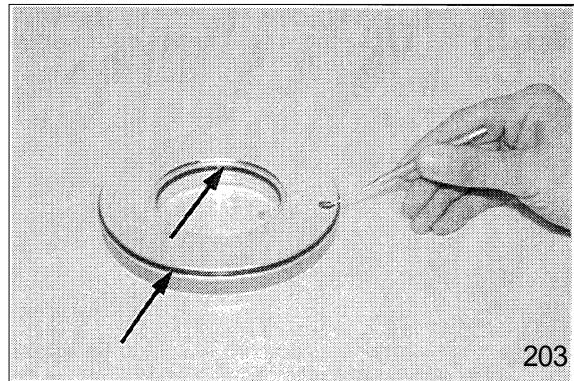

Introduce piston until contact is obtained.  
Pay attention to the installation position,  
see figure.

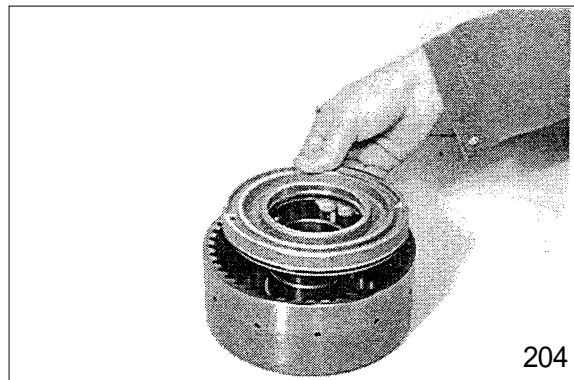

Install cup-spring pack and guide ring.  
Pay attention to the stacking of the cup  
springs, see the next draft.

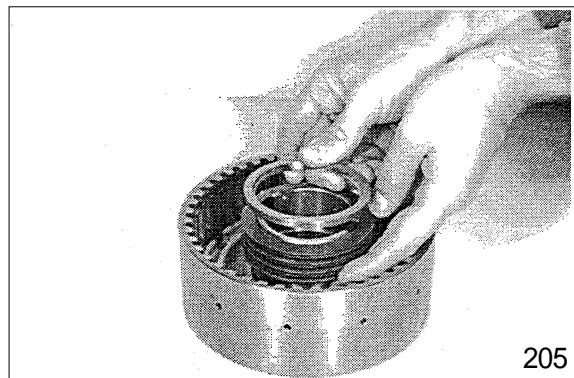

Preload cup-spring pack and fix it by  
means of snap ring.  
Assembly aid 5870 345 088

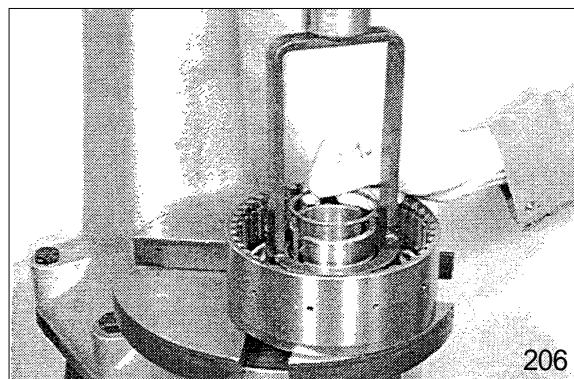

### Plate pack K4

The following draft shows the installation position of the components.

- 1 Plate carrier
- 2 Piston
- 3 Outer plate-one side coated(1 piece)
- 4 Inner plates(5 pieces)
- 5 Outer plates-coated on both sides (5 pieces)
- 6 Snap ring(Optional s= 2.1~4.2mm)
- 7 End shim

Effective number of friction surfaces = 10

Install outer plate 3 with the uncoated side facing the piston.

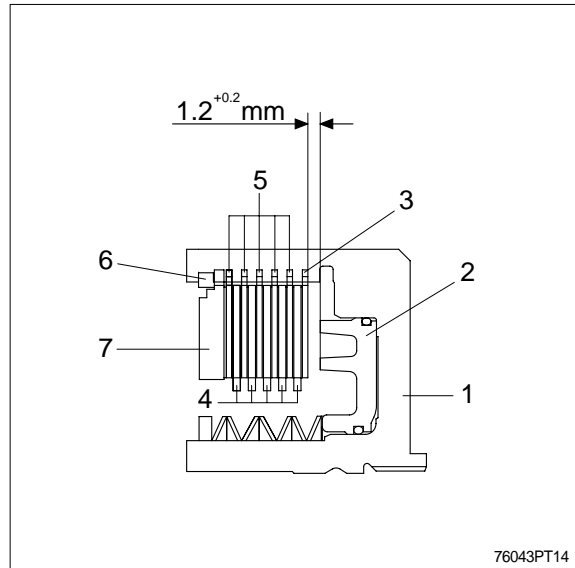

### Adjust plate clearance = $1.2^{+0.2}$ mm

For the adjustment of the plate clearance are snap rings of different thickness available.

To ensure a faultless measuring result, install plates for the moment without oil. Introduce plate pack according to the draft.

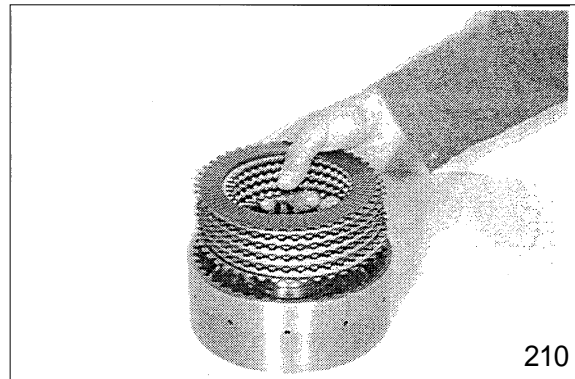

Lay on end shim and squeeze snap ring in(e.g. s= 3.4mm).



Press on the end shim with about 100N (10kg), apply dial indicator and set it at zero.

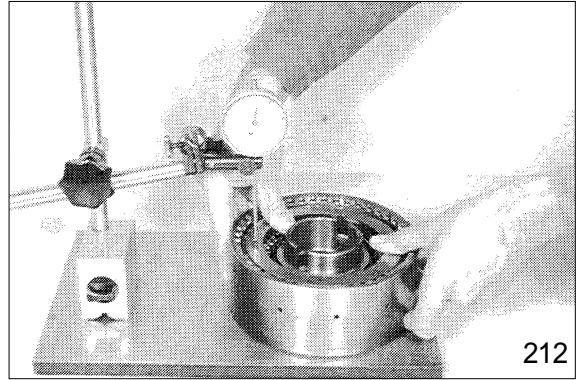

Now, push the end shim by means of screw driver against snap ring until contacts is obtained(Upward) and read plate clearance on the dial indicator.

In case of a deviation from the required plate clearance, correct with corresponding snap ring(s=2.1~4.2mm).

After the adjustment of the plate clearance has been carried out, remove the plate pack, oil plates and install it again.

Use oil Dexron- D, /Mercon-M.

Magnetic stand 5870 200 055

Dial indicator 5870 200 057

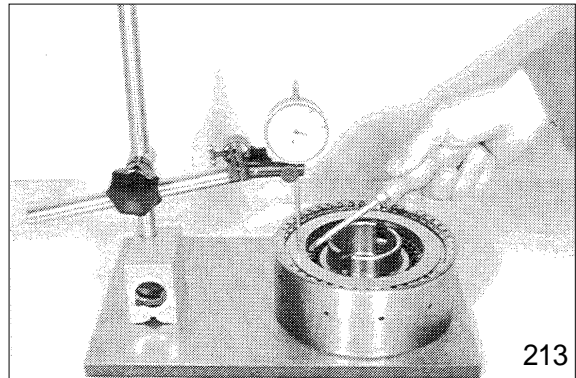

Introduce idler gear until all inner plates are accommodated.

This step makes the later assembling of the idler gear easier.

Now, remove idler gear again.

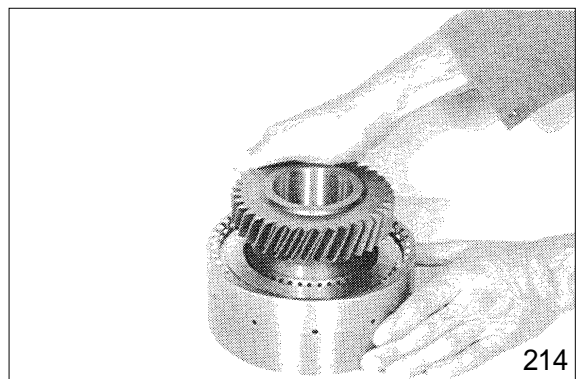

Assemble both axial washers as well as needle case.

Upper and lower axial washer have the same thickness(55 x 78 x 1).

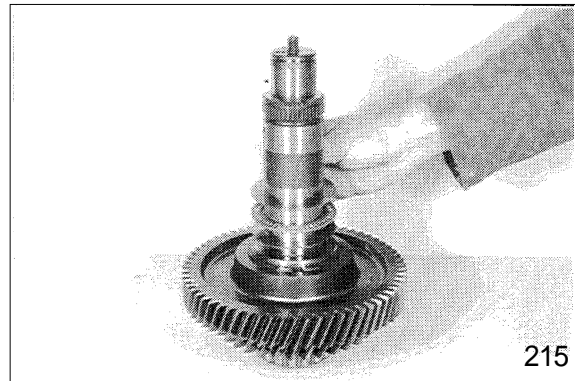

Assemble both needle bearings.

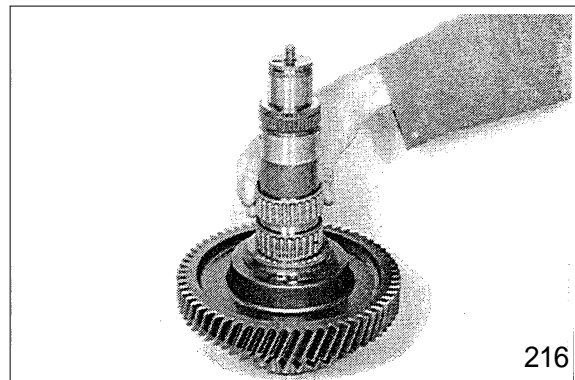

Assemble idler gear.

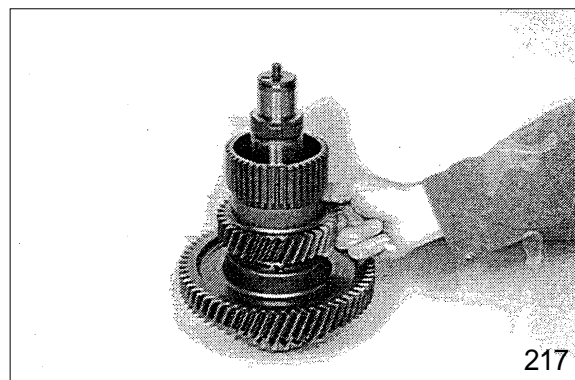

Assemble axial washer 3(55 x 78 x 1), needle cage 2 and running disk 1(55 x 78 x 5).

Install running disk 1, with the chamfer facing the needle cage.

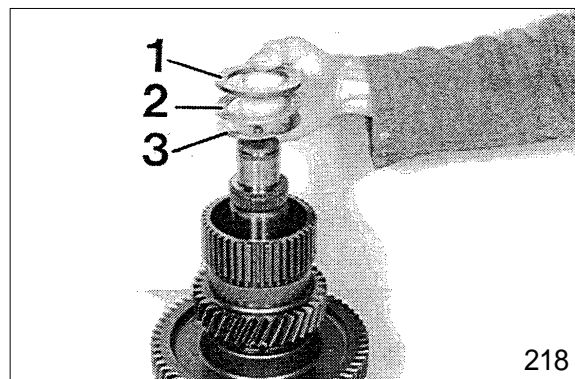

Heat inner diameter of the plate carrier  
(About 120°C).

Assemble preassembled plate carrier  
until all inner plates are accommodated.

Use safety gloves.

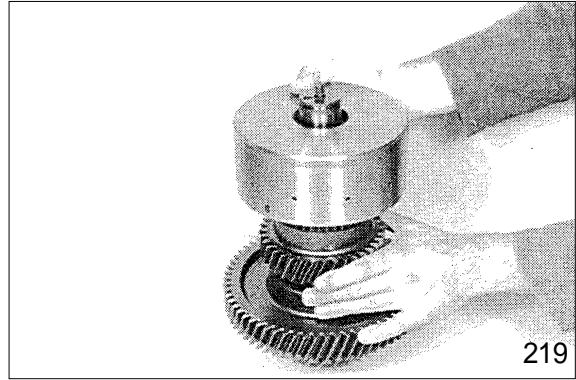

Fix plate carrier axially by means of  
circlip.

Set of external pliers 5870 900 015

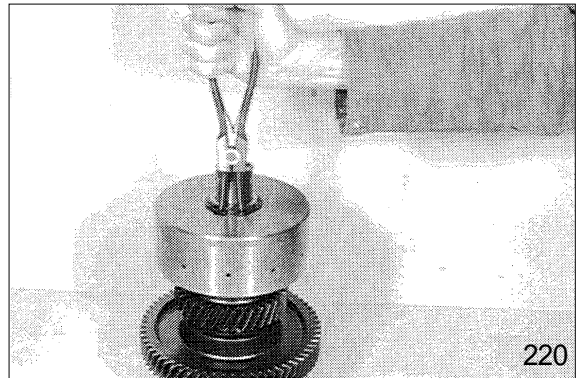

Check function of the clutch by means of  
compressed air.

At correctly installed components, the  
closing respectively opening of the clutch  
is clearly audible.

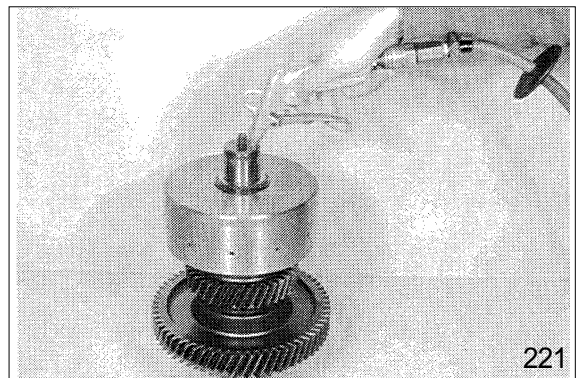

Press tapered roller bearing against  
shoulder.

Install opposite tapered roller bearing.

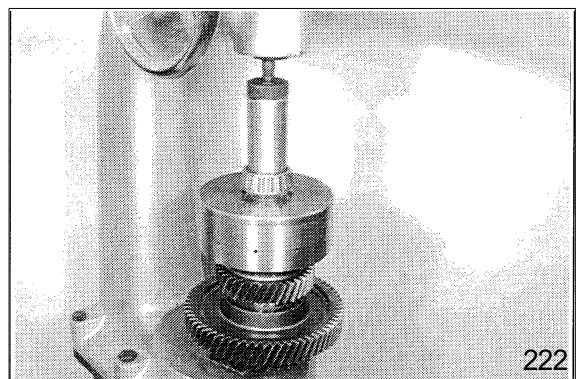

- ) Squeeze rectangular ring in(Arrow) and let it snap in.  
Install opposite rectangular ring.

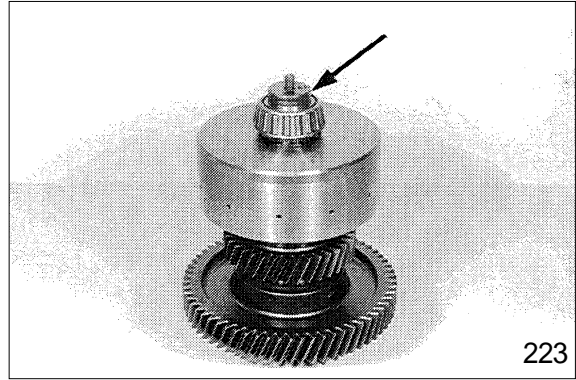

**(5) Preassemble drive shaft**

Undercool the drive shaft(About  $-80^{\circ}\text{C}$ ),  
heat the gear(About  $+120^{\circ}\text{C}$ ) and  
assemble it until contact is obtained.

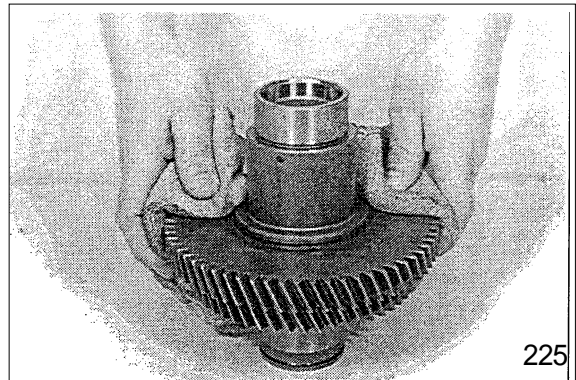

Fix gear axially by means of circlip.

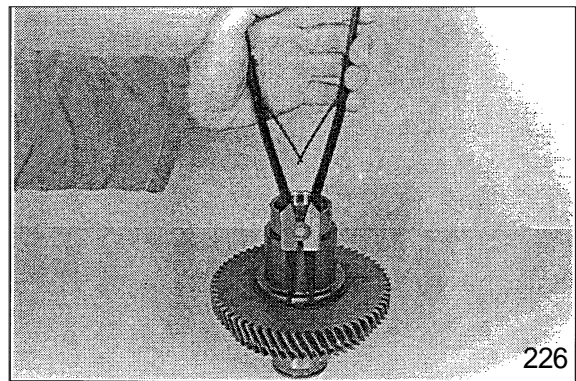

Squeeze snap ring into groove of the  
turbine shaft.

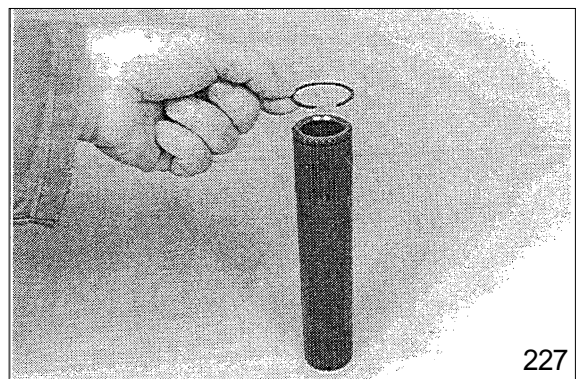

Introduce turbine shaft until the snap ring snaps into the groove of the drive shaft  
turbine shaft is axially fixed.

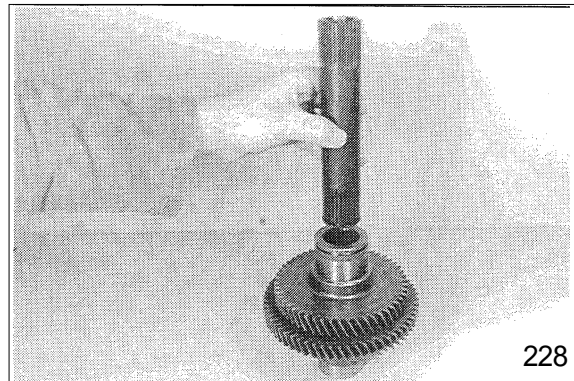

Press tapered roller bearing against shoulder.  
Now, squeeze rectangular ring into the groove of the drive shaft and let it snap in.  
Install opposite tapered roller bearing.

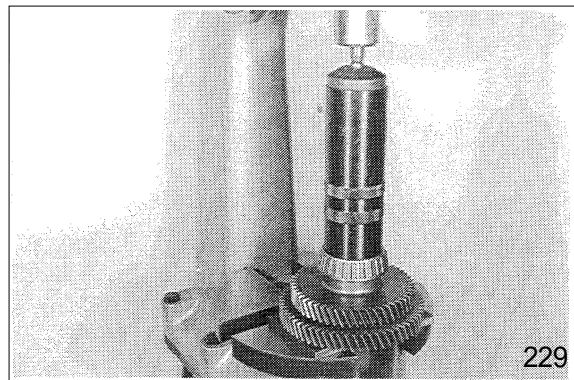

**(6) Preassemble and install output**

Lay on screening plate

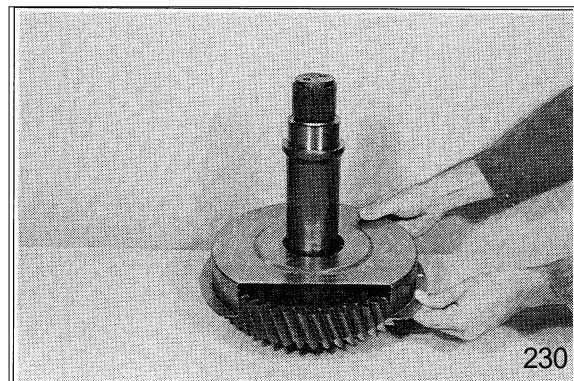

Heat tapered roller bearing and assemble it until contact is obtained.  
Install opposite tapered roller bearing accordingly.

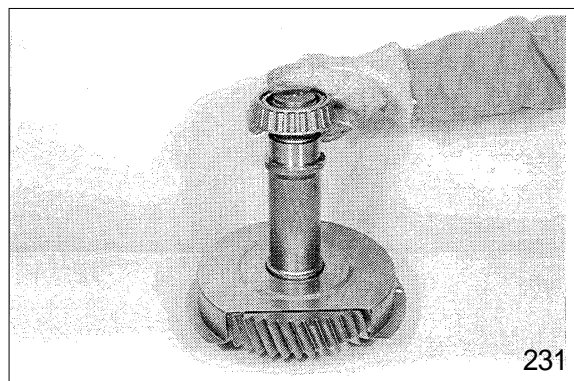

Insert all bearing outer races into the bearing bores of the housing.

Install O-ring(Arrows).

At the use of already run bearings, pay attention to the allocation of the bearing outer races, see also note/page 3-89.

- AN Input
- KV Clutch-Forward
- KR Clutch-Reverse
- K1 Clutch-1st speed
- K2 Clutch-2nd speed
- K3 Clutch-3rd speed
- K4 Clutch-4th speed
- AB Output

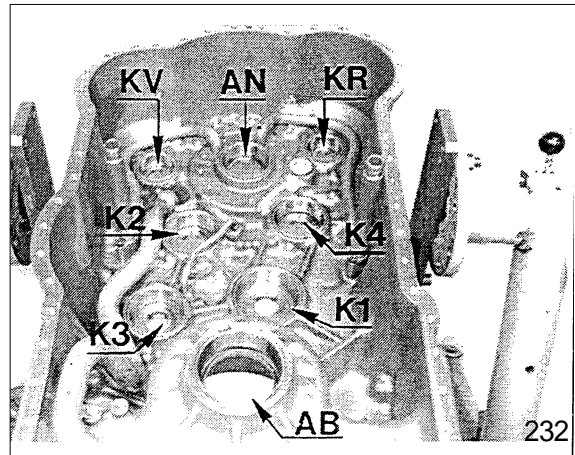

Lay on screening plate.

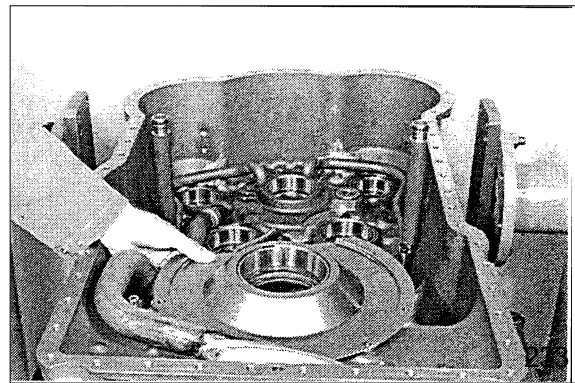

Insert preassembled output shaft.

Fix screening plates by means of socket head screws.

- Torque limit(M8/8.8) : 2.3kgf · m  
(17.0lbf · ft)

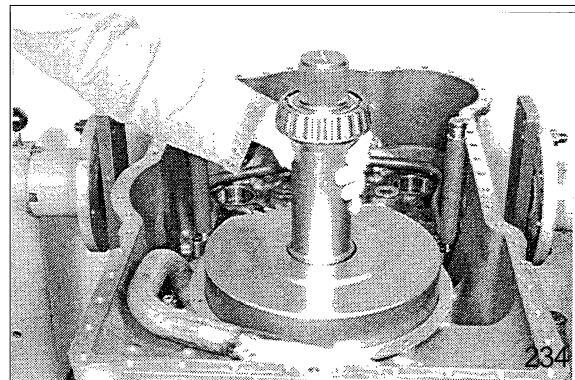

**(7) Install preassembled drive shaft and clutches**

Insert all bearing outer races into the bearing bores of the housing cover.

At the use of already run bearings, pay attention to the allocation of the bearing outer races, see also note/page 3-89.

- AN Input
- KV Clutch-Forward
- KR Clutch-Reverse
- K1 Clutch-1st speed
- K2 Clutch-2nd speed
- K3 Clutch-3rd speed
- K4 Clutch-4th speed
- AB Output

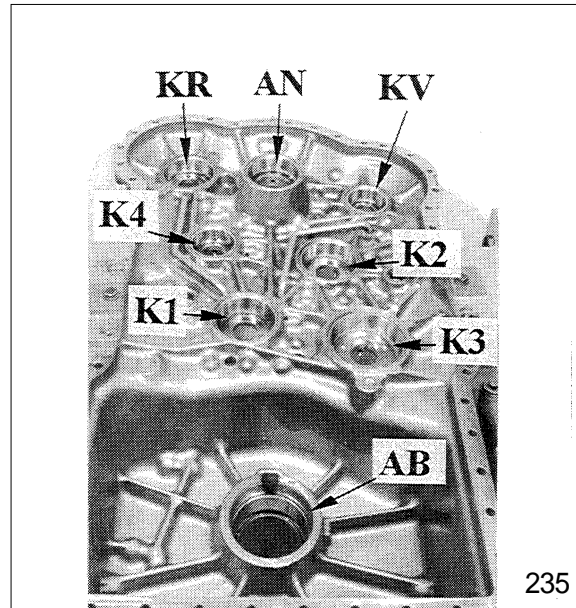

Prior to the installation of the clutches and the drive shaft, grease rectangular rings and align them centrally.

Insert clutch KR, drive shaft and clutch KV together into the housing cover.

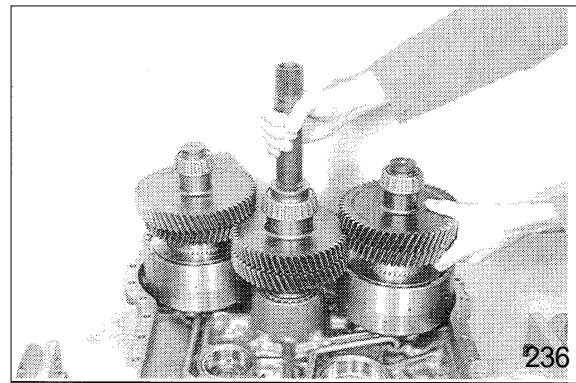

Lift drive gear and position clutch K4.

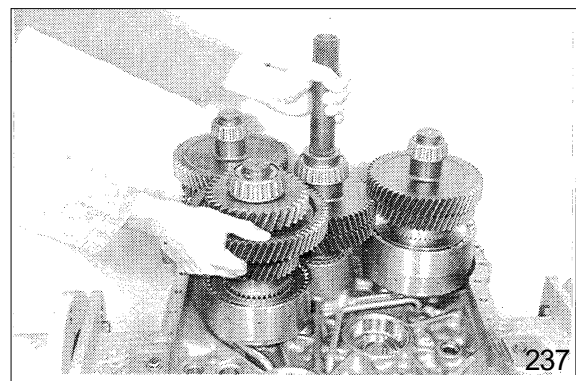

Install clutch K3.

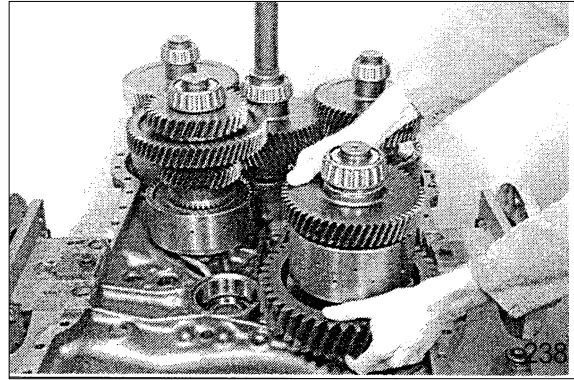

Position clutch K2.

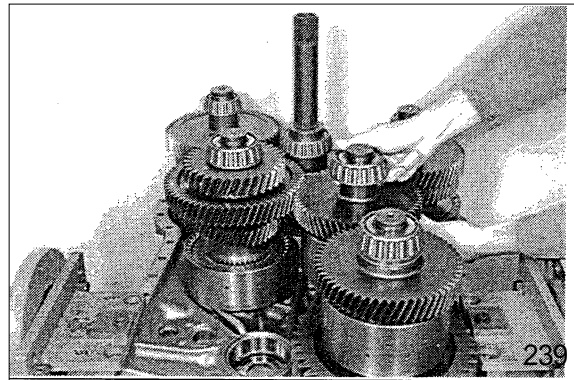

Lift clutch K4 and position clutch K1.

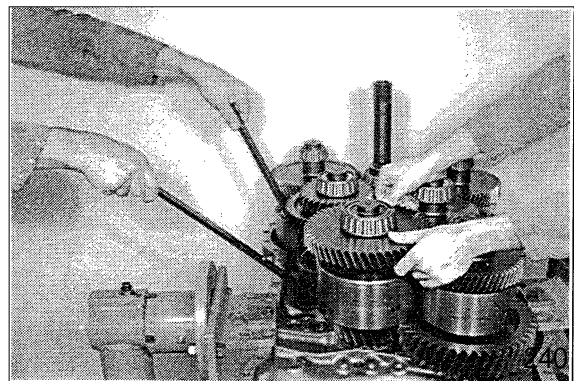
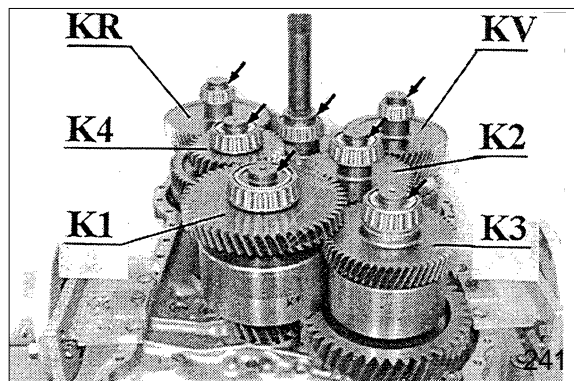
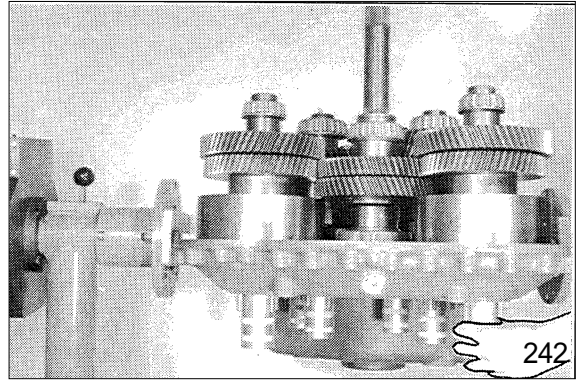

Illustration on the right shows the installation position of the single clutches in the housing cover. Grease rectangular rings (Arrows) and align them centrally.



Fix all clutches by means of handles.  
Handle(6 pieces needed) 5870 260 010



Tilt housing cover 180°.  
Install eye bolts(Arrows).

Eye bolt(M20, 2EA) 0636 804 003  
Eye bolt(M16, 1EA) 0636 804 001  
Puller device 5870 000 017

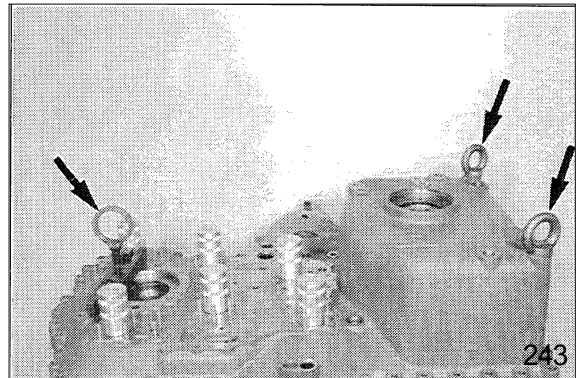

Grease O-rings of the two oil tubes.  
Wet mounting face with sealing compound loctite(Type No.574).  
Position preassembled housing cover by means of lifting device carefully on the gearbox housing until contact is obtained.  
Pay attention to the overlapping of the oil tubes with the bores in the housing cover.  
Lifting chain 5870 281 047

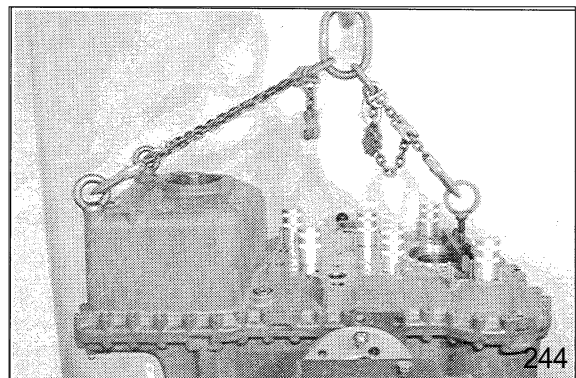

Remove handles again.

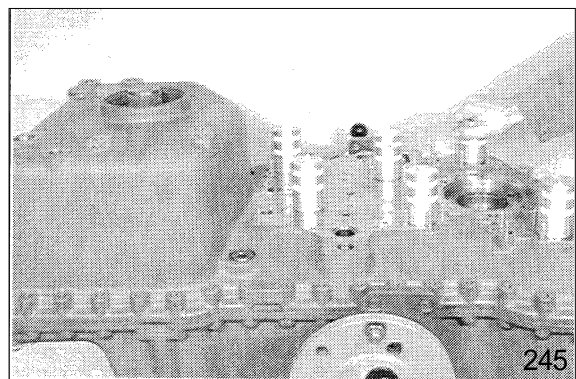

Install both cylindrical pins centrally to the housing face.

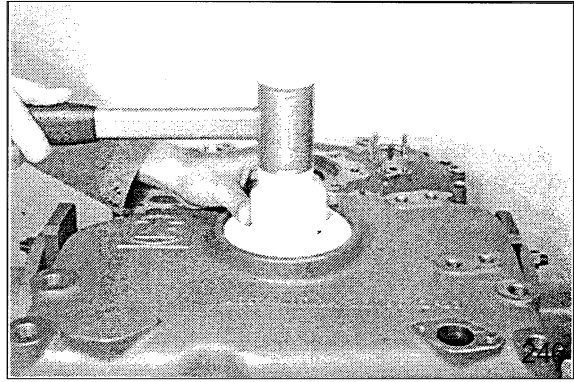

Fasten housing cover by means of hexagon head screws.

- Torque limit(M10/8.8) : 4.7kgf · m  
(33.9lbf · ft)

Pay attention to position of the fixing plate, see Arrow.

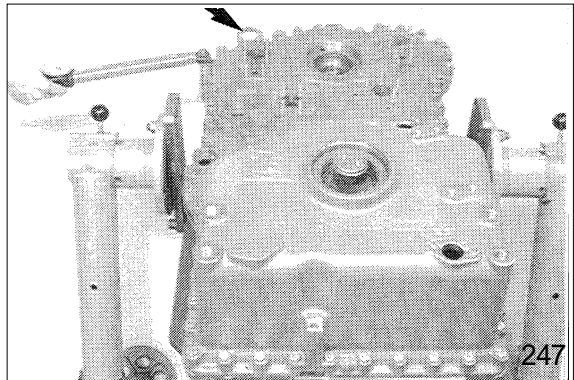

**(8) Install pump shaft(Power take off)**

Install ball bearing.

Squeeze rectangular ring in(Arrow) and let it snap in.

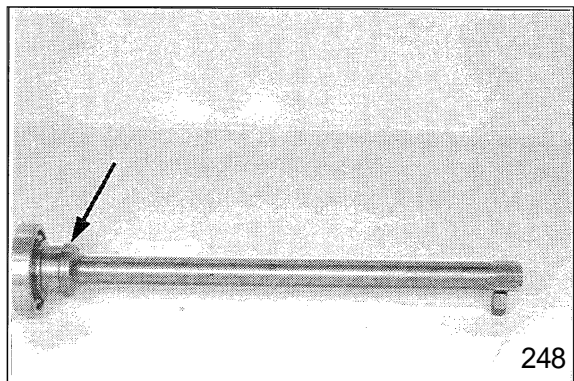

Grease rectangular ring, align it centrally and introduce pump shaft until contact is obtained.

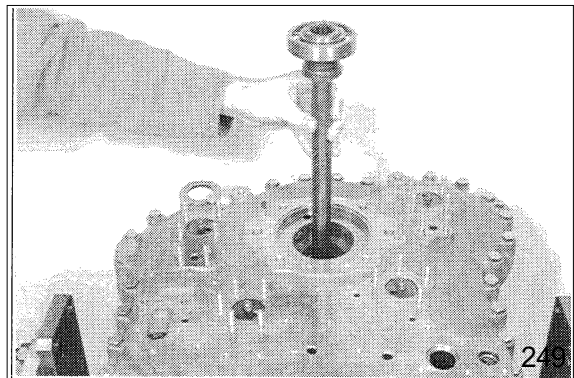

Fix pump shaft by means of circlip.

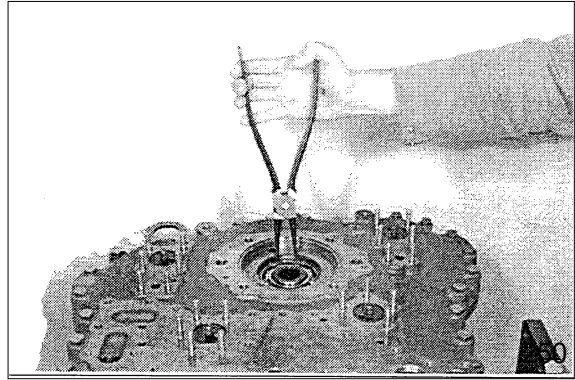

Insert O-ring(Arrow) into the annular groove of the oil feed covers.

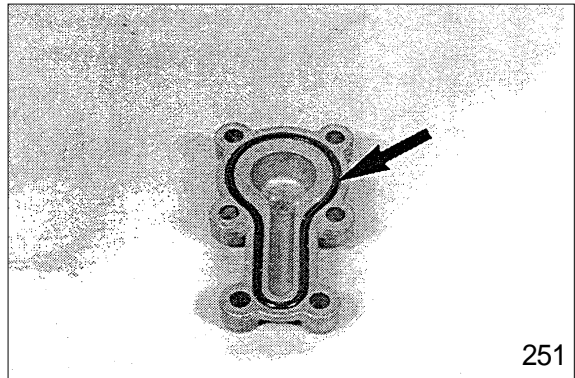

Fasten both covers(Arrows) by means of hexagon nuts(Use plain washers).  
· Torque limit : 2.3kgf · m(17.0lbf · ft)

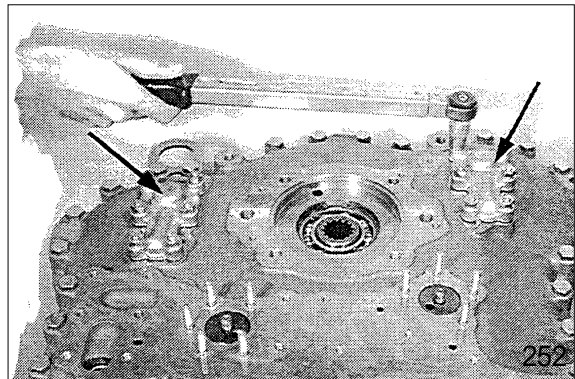

### (9) Install output flanges

Install shaft seal with the sealing lip facing the oil chamber.

At the use of the prescribed driver, the exact installation position is obtained.

Wet rubber coated outer diameter with spirit.

Grease sealing lip.

Driver

5870 048 213

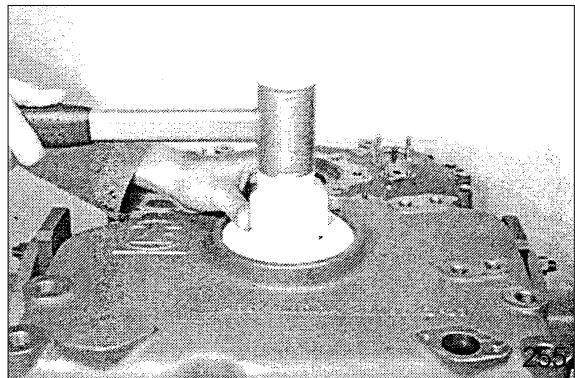

Assemble output flange.  
 Insert O-ring(Arrow) into the gap of drive flange and shaft.

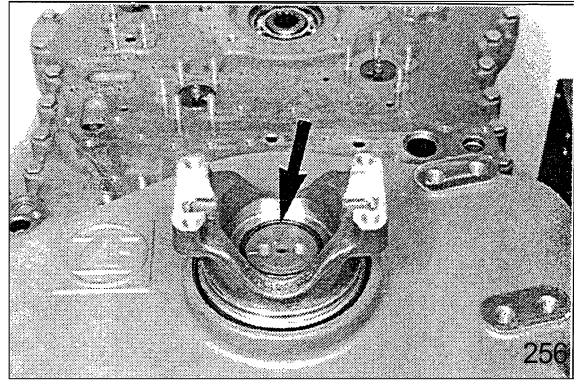

Fasten output flange by means of disk and hexagon head screws.  
 · Torque limit(M10/8.8) : 4.7kgf · m  
 (33.9lbf · ft)

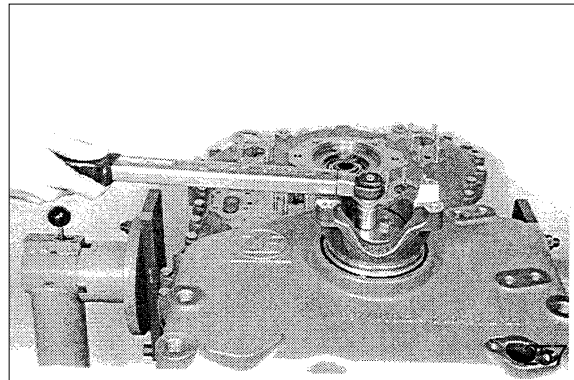

Fix hexagon head screws by means of lock plate.  
 Driver 5870 057 009  
 Handle 5870 260 002  
 Install converter side output flange accordingly.

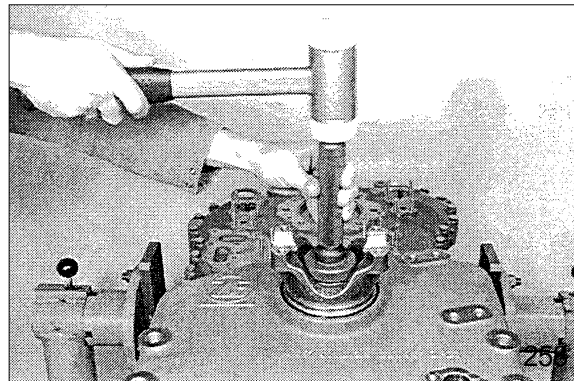

**(10) Converter back pressure valve**

Illustration on the right shows the components of the converter back pressure valve.

- 1 Piston
- 2 Compression spring
- 3 Pressure plate
- 4 Lock plate

Install pressure plate with the spigot (Ø6mm) facing the lock plate.

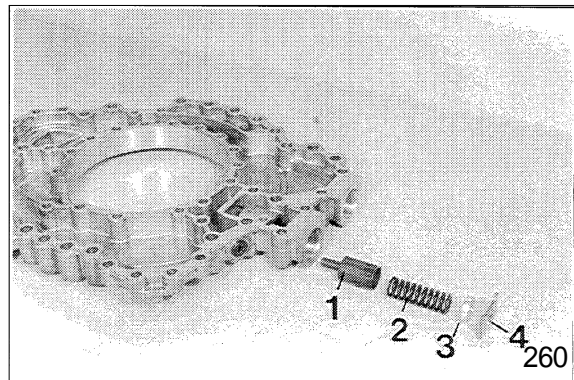

Introduce components according to figure (10) ①, preload and fix by means of lock plate.

Equip plug(Arrow) with new O-ring and install it.

- Torque limit(M14 x 1.5) : 2.5kgf · m  
(18.4bf · ft)

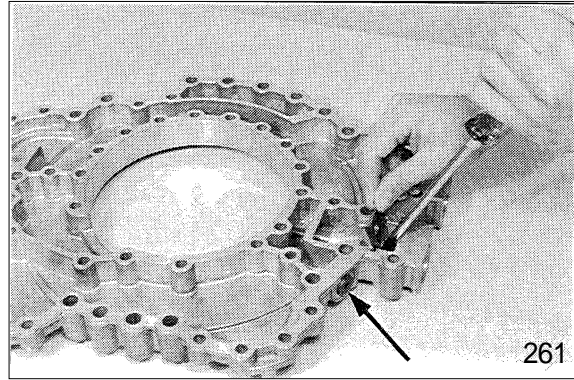

#### (11) Oil feed housing-Transmission pump

Install two adjusting screws(Arrows) and lay on gasket.

Adjusting screws(M8) 5870 204 011

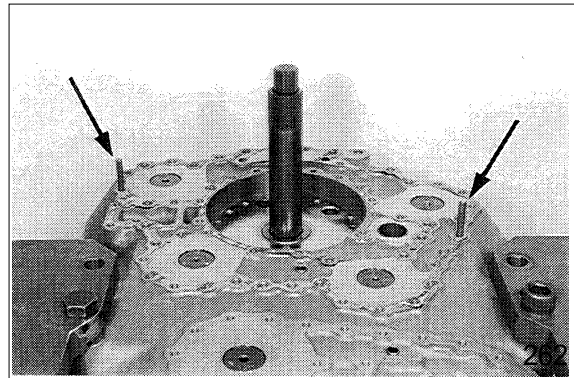

Lay on oil feed housing and fix it provisionally by means of socket head screws.

Screw socket head screws only in until contact is obtained **do not tighten.**

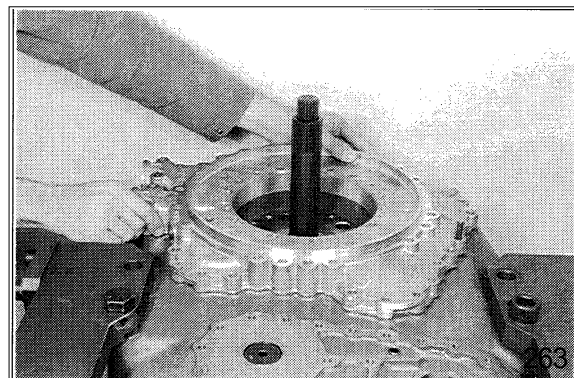

Install two adjusting screws and introduce stator shaft until contact is obtained.

Pay attention to the overlapping of the bores.

Adjusting screws(M10) 5870 204 007

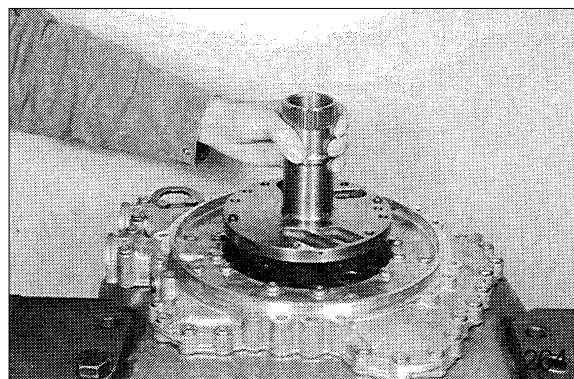

Insert O-ring(Arrow) into the annular groove and oil it.

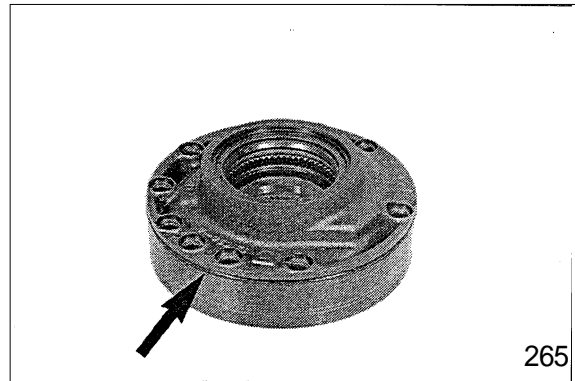

Introduce transmission pump(Complete) and put it by means of socket head screws(For the moment without O-rings) evenly against shoulder. Now, remove socket head screws again.

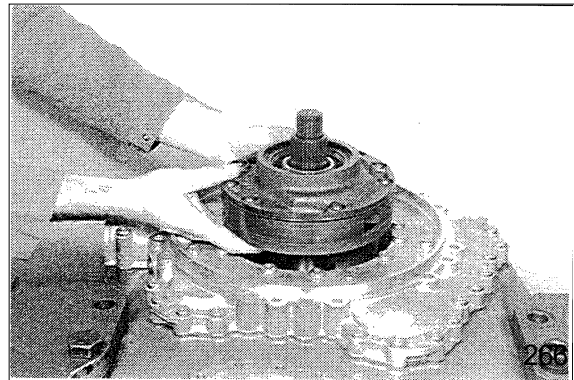

Equip socket head screws with new O-ring(Arrow). Grease O-rings.

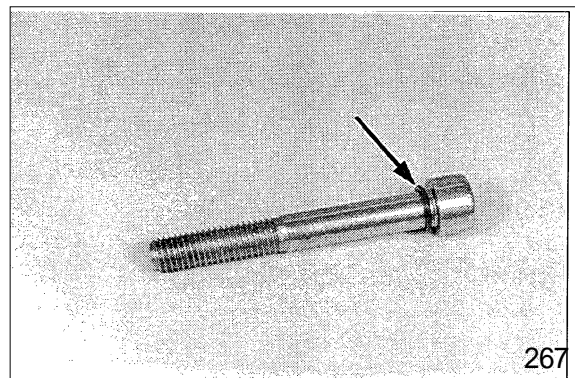

Fasten transmission pump by means of socket head screws.

- Torque limit : 4.7kgf · m(33.9lbf · ft)

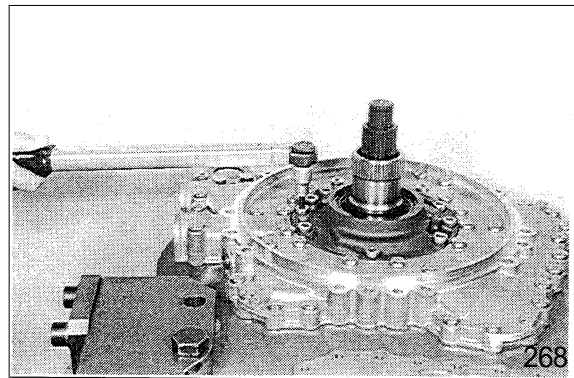

Fasten oil feed housing by means of socket head screws and hexagon head screws(2 pieces).

- Torque limit
  - Socket head screw : 2.3kgf · m  
(16.6bf · ft)
  - Hexagon head screw : 4.7kgf · m  
(33.9bf · ft)

Pay attention to the position of the fixing plate, see Arrow.

Box spanner(Torx, TX-40) 5873 042 004

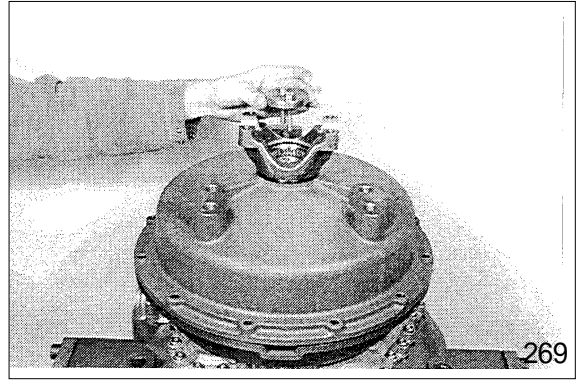

### (12) Engine connection-Converter

Fasten converter bell by means of hexagon head screws.

- Torque limit(M10/10.9) : 6.9kgf · m  
(50.1bf · ft)

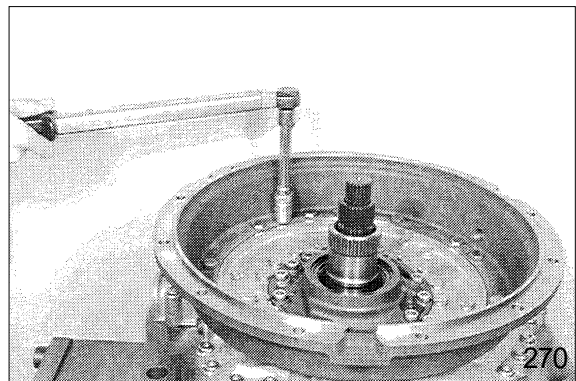

Screw drive shaft and diaphragm together.

- Torque limit(M12/10.9) : 11.7kgf · m  
(84.8bf · ft)

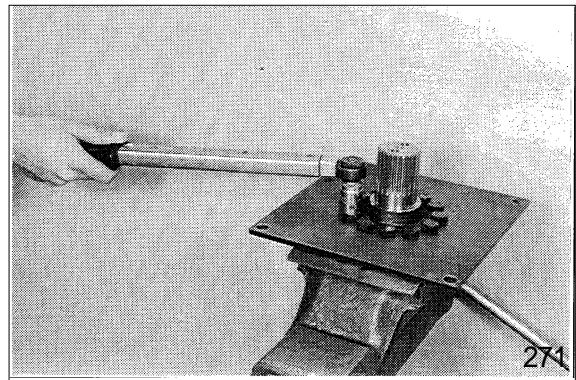

Fasten diaphragm by means of hexagon head screws on the converter.

- Torque limit(M12/10.9) : 11.7kgf · m  
(84.8bf · ft)

Insert hexagon head screws with loctite (Type No.262).

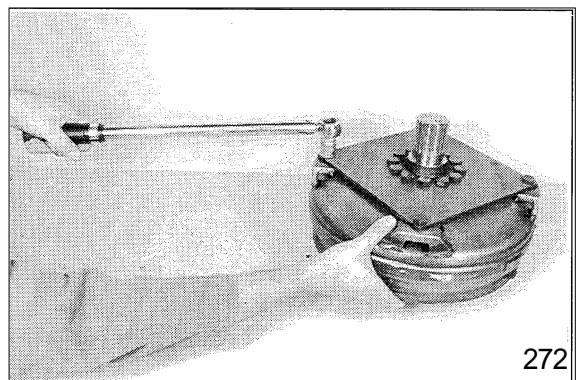

Introduce converter until contact is obtained.

Pulse disk of the converter must be positioned centrally to the bore of the inductive transmitter, see Arrow.

Only in this way will be ensured that the converter is perfectly introduced.

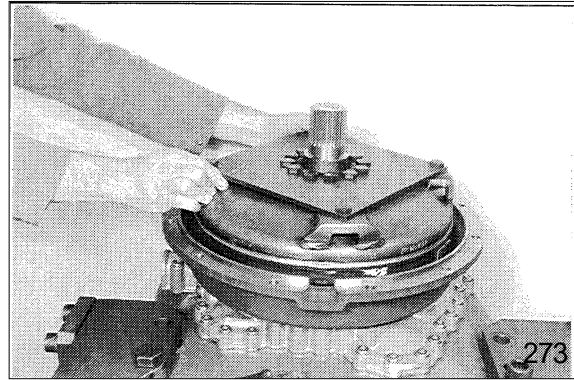

Insert ball bearing until contact is obtained and fix it by means of circlip.

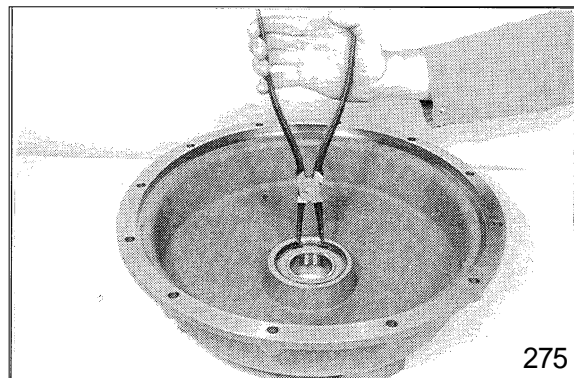

Assemble housing cover.

Install drive flange, lay on disk and pull cover by means of hexagon head screws evenly against shoulder.

- Torque limit(M8/10.9) : 3.5kgf · m  
(25.1bf · ft)

Pay attention to the radial installation position of the cover, see figure.



Fix hexagon head screws by means of lock plate.

Driver 5870 057 010

Handle 5870 260 002

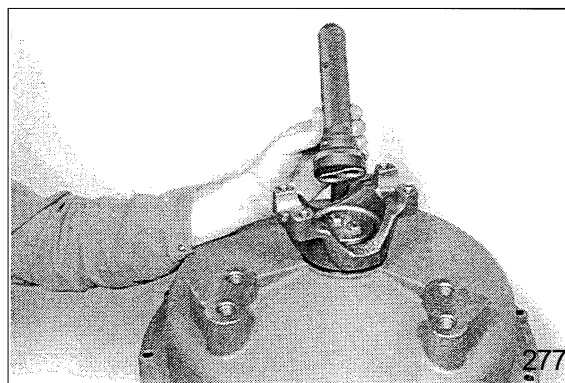

Fasten cover by means of hexagon head screws and nuts on the converter bell.

- Torque limit(M10/838) : 4.7kgf · m  
(33.9lbf · ft)

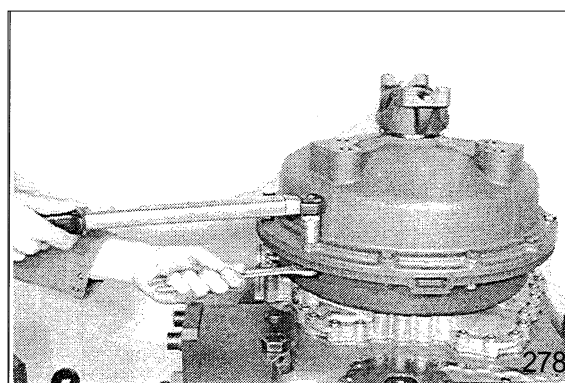

Mount gasket and fasten cover by means of hexagon head screws.

- Torque limit(M8/8.8) : 2.3kgf · m  
(17.0lbf · ft)

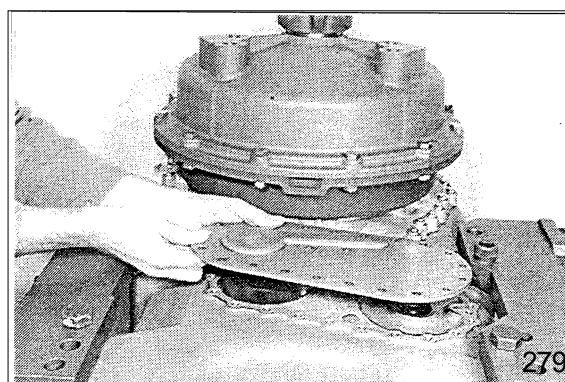

### (13) Converter safety valve

Insert converter safety valve(Complete) into the housing hose.

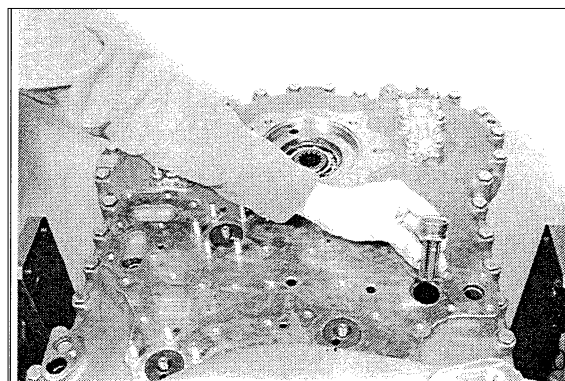

**(14) Mount duct plate and hydraulic control unit**

Install components according to the following draft.

- Torque limit(M8) : 2.3kgf · m(17.0lbf · ft)

Pay attention to the installation position of the different gaskets, see draft.

- 1 Gasket
- 2 Duct plate
- 3 Gasket
- 4 Intermediate plate
- 5 Gasket

Adjusting screws                    5870 204 063

Box spanne                         5873 042 004

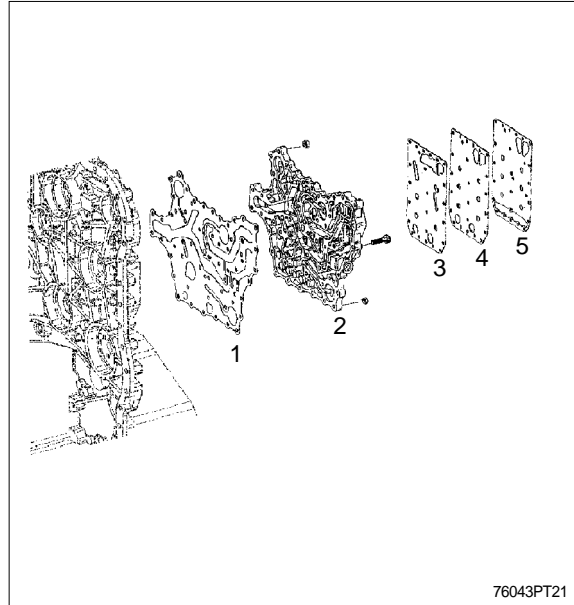

Equip screw plug(Arrow) with new O-ring and install it.

- Torque limit(M16 × 1.5) : 3.0kgf · m  
(21.7lbf · ft)

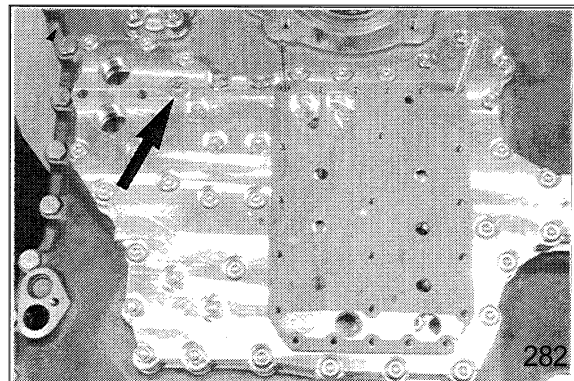

Fasten hydraulic control unit(HSG-94) by means of socket head screws.

- Torque limit(M6) : 0.97kgf · m(7.0lbf · ft)

Adjusting screws                    5870 204 063

Box spanner(Torx Tx-27)       5873 042 002

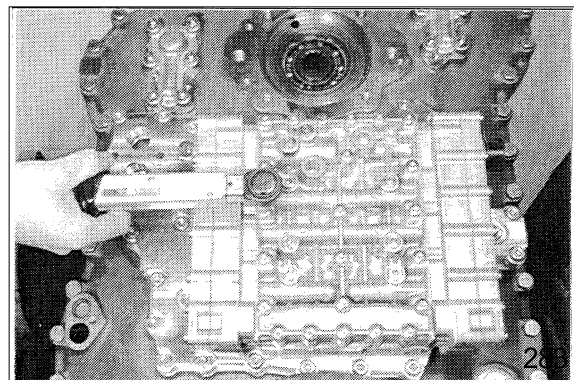

**(15) Install plugs and oil level tube**

Equip both plugs(Arrows) with new O-rings and install them.

- Torque limit(M18 × 1.5) : 5.1kgf · m  
(36.9lbf · ft)
- Torque limit(M26 × 1.5) : 8.2kgf · m  
(59.0lbf · ft)

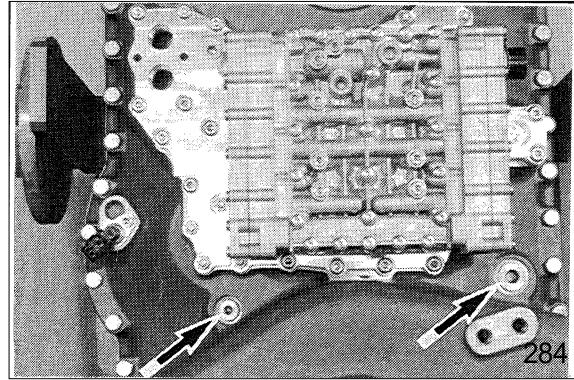

Install oil level tube(Arrow).  
Mount new gasket.

- Torque limit(M8/10.9) : 3.5kgf · m  
(25.1lbf · ft)

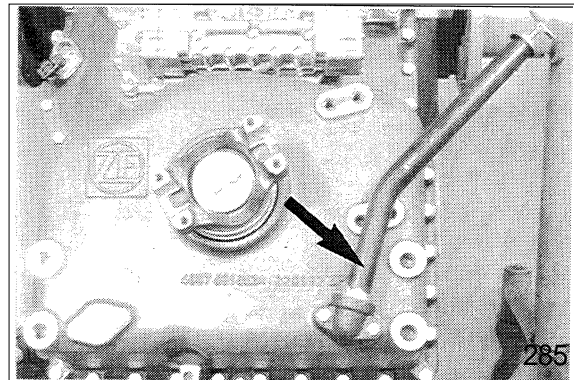

Install cover plate(Arrow 1).  
Install new gasket.

- Torque limit(M8/8.8) : 2.3kgf · m  
(17.0lbf · ft)

Equip screw plug(Arrow 2) with new O-ring and install it.

- Torque limit(M38 × 1.5) : 14.3kgf · m  
(103lbf · ft)

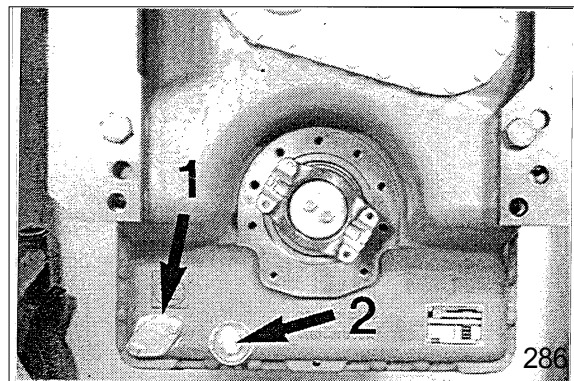

**(16) Speed sensor and inductive transmitters**

The figures show the installation position of the single inductive transmitters and the speed sensor.

- 34 Speed sensor  
n-Output and speedometer
- 21 Inductive transmitter  
n-Turbine
- 47 Inductive transmitter  
n-Central gear train
- 48 Inductive transmitter  
n-Engine

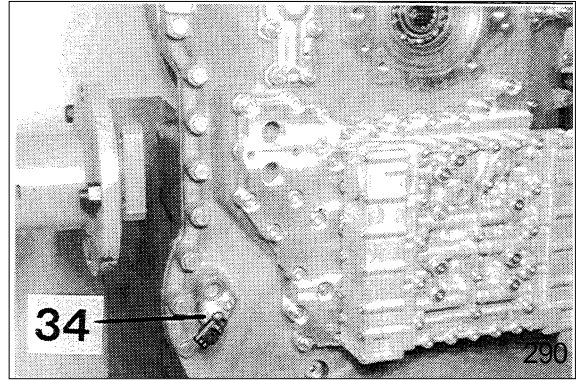

Grease O-rings and install speed sensor as well as inductive transmitters.

- Torque limit : 2.3kgf · m(17.0lbf · ft)  
(Socket head screw/Speed sensor)
- Torque limit : 3.1kgf · m(22.1lbf · ft)  
(Inductive transmitter)

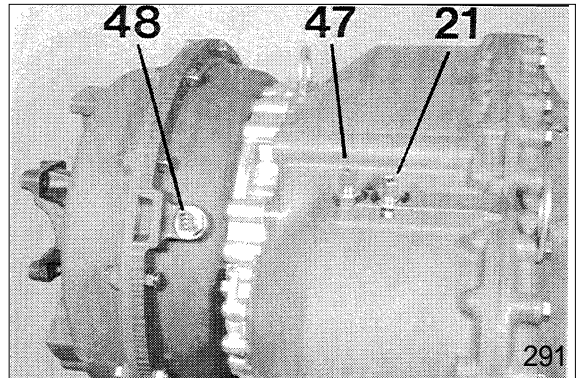

Install breather(Arrow).

- Torque limit : 1.2kgf · m(8.9lbf · ft)

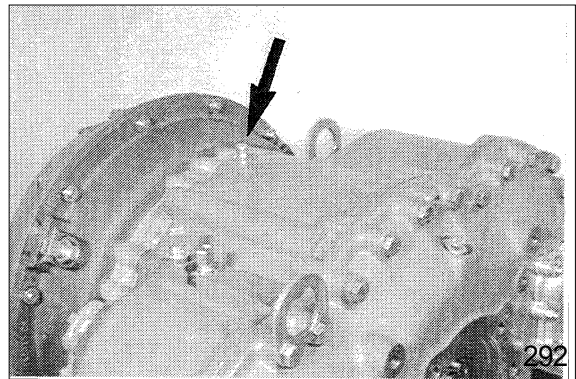

### **3. AXLE**

#### **1) GENERAL INSTRUCTIONS**

##### **(1) SHIMS**

All adjustments shall be carried out after all adjustment shims have been selected measuring them one by one with a micrometer gauge and, then, summing up all values measured; don't trust incorrect measurement of pack as a unit or sum of nominal value printed on each shim.

##### **(2) SEALS FOR REVOLVING SHAFTS**

Proceed as follows for proper fitting of captioned seals:

Prior assembly, seals should be kept, for at least half an hour, in a bath with the same oil to be sealed;

Clean thoroughly shaft and make that working surface be not damaged;

Position sealing lip against the fluid to be sealed; in case of hydrodynamic lip lines should be oriented so as that, considering direction of revolving shaft, they lead fluid inside of sealing means;

Smear sealing lip with a film of lubricant(oil is better than grease) and fill up with grease the space between sealing lip and dust shield lip, if using double sealing lip type seals;

Press seal in relevant seat or use a proper fitter with flat contact surface; never use hammer or mallet to mount seal;

When press fitting seal make sure that it be correctly driven in relevant seat, i.e., perpendicular with respect to its seat, as fitting is completed make sure, if required, that seal itself be in contact with relevant shoulder;

To prevent damage of seal lip when inserting shaft, duly protect component during assembly.

##### **(3) O-RING SEALS**

Lubricate O-RING seals at assembly to prevent twisting that would impair correct sealing.

Clean matching surface as follows prior, smearing compound:

Remove old deposits using a metal brush;

Degrease surfaces by one the following cleaners: trichloroethylene, kerosene or a warm water and soda solution.

##### **(4) BEARINGS**

When assembling them it is advisable to proceed as follows:

Heat them with 80 to 90°C before fitting on relevant shafts;

Cool them before inserting in relevant external seats.

##### **(5) SPRING PINS**

When using split pins be sure that lengthwise cleft be positioned toward stress on pin.

Coil pins don't require specific position.

## 2) REDUCTION ASSEMBLY

### (1) DISASSEMBLY

Turn the plug toward top position and remove the plug for the air vent.  
Assemble the plug temporarily.

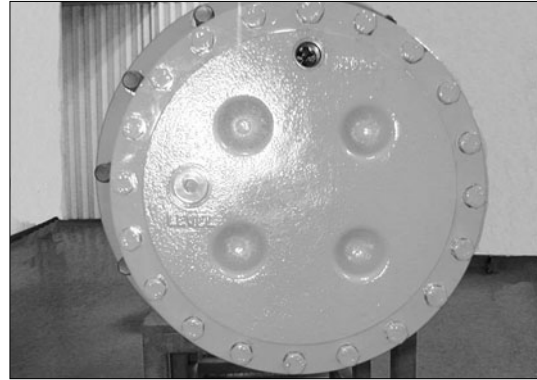

757AX01

Drain oil from final drive unit.

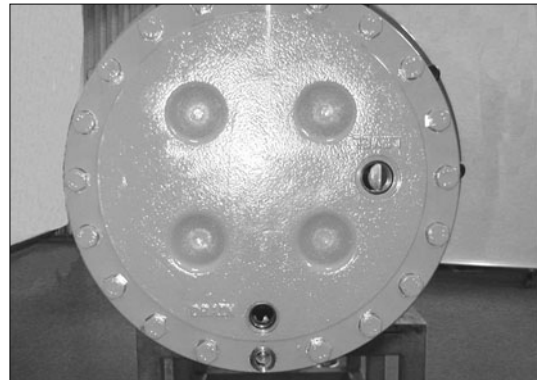

757AX02

It is provided with two threaded holes (M14 x 2) to be used for puller screws.

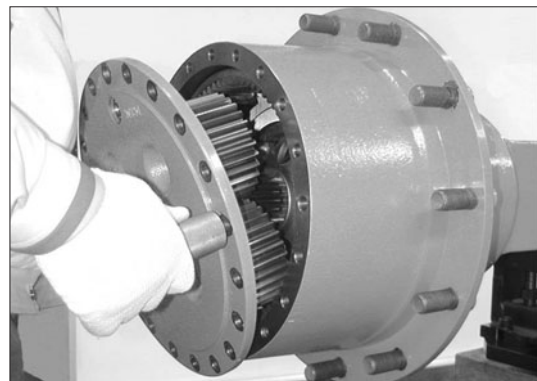

757AX03

Remove retain ring.

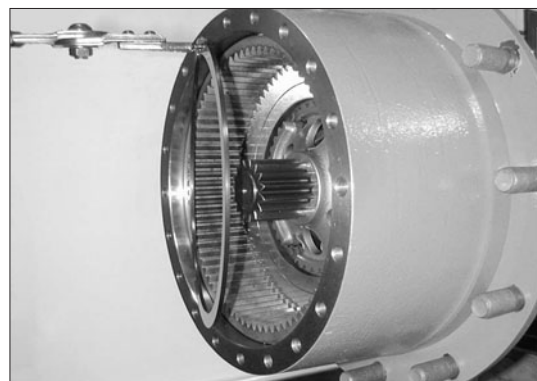

757AX04

Pull out shaft assy with shaft, drum and washer.

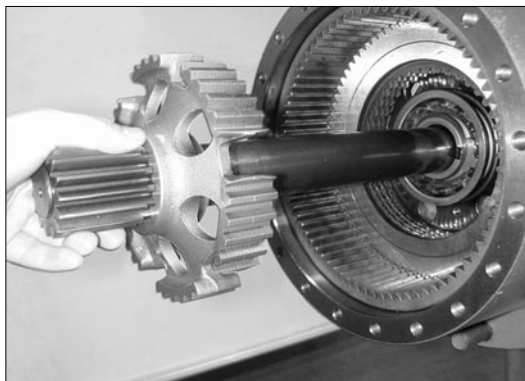

757AX05

Remove brake plate.

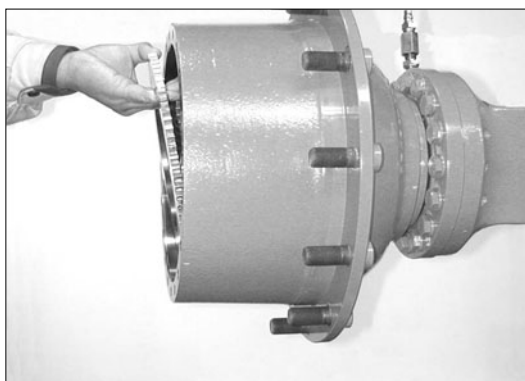

757AX06

Remove brake disc pack.

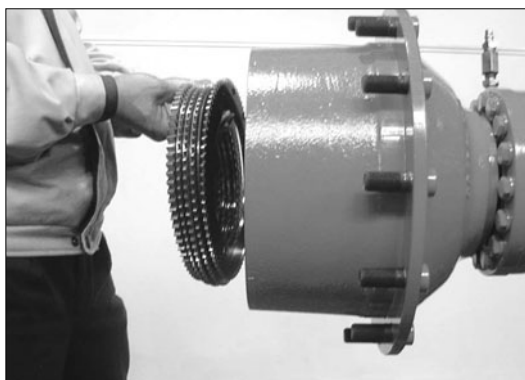

757AX07

Remove lock ring nut locks.



757AX08

Remove locks.

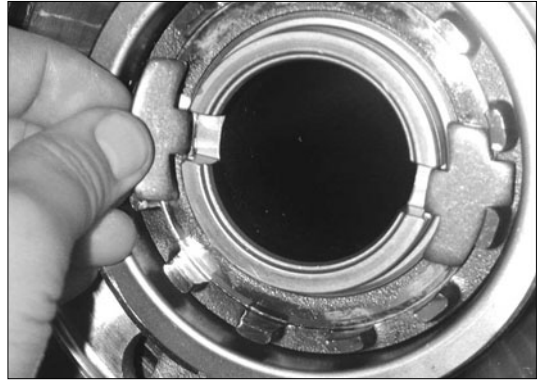

757AX09

Install the proper tool on pressure plate and apply the eye bolt(3EA) temporarily. Tighten the eye bolt tool perfectly.

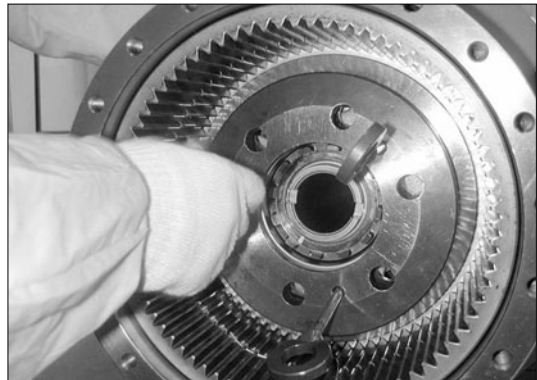

757AX10

Remove the adjusting nut by the use of the special tool.

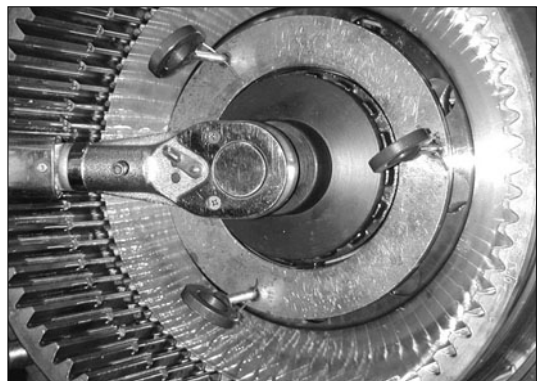

757AX11

Remove the pressure plate, return spring, cover and compression tool.

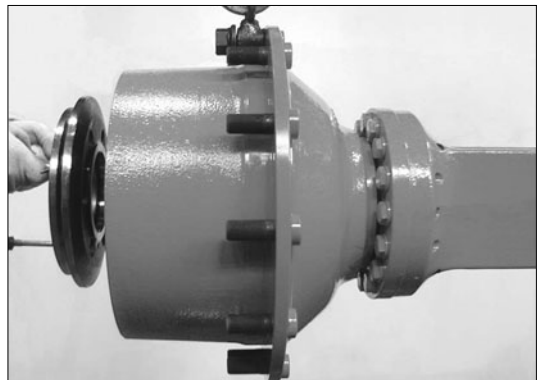

757AX12

Remove the ring gear assembly.  
Attention to the weight.



757AX13

Pry off lock ring from ring gear by a screw driver and remove ring gear support.

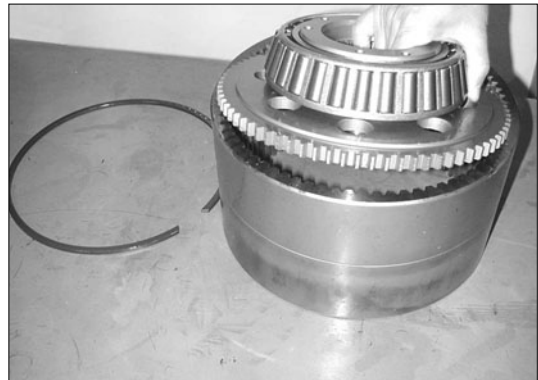

757AX14

Remove piston, it's easier by blowing compressed air in brake oil delivery ducting.

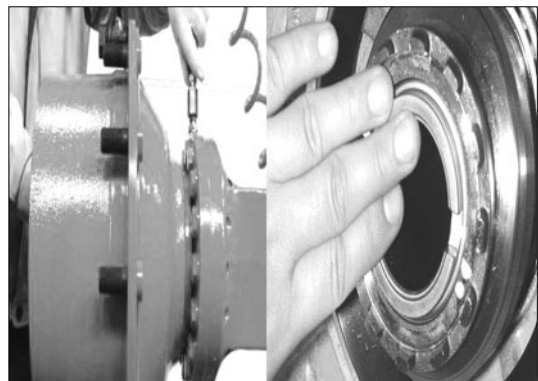

757AX15

Remove wheel hub assembly.

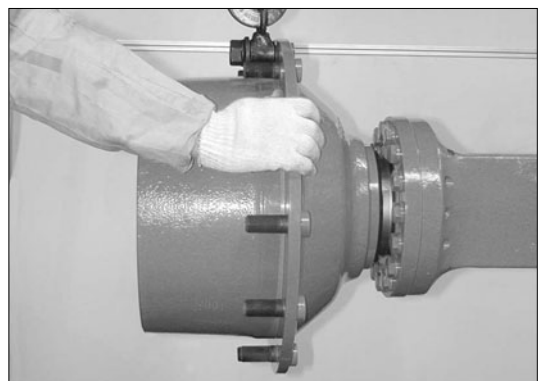

757AX16

Pry off wheel hub seal and remove inner race with roller cage of wheel inside bearing. By using a punch remove from wheel hub outer races of inner and outer bearings.



757AX17



757AX18

Remove bearing cup.



757AX19

Remove O-ring from brake piston.

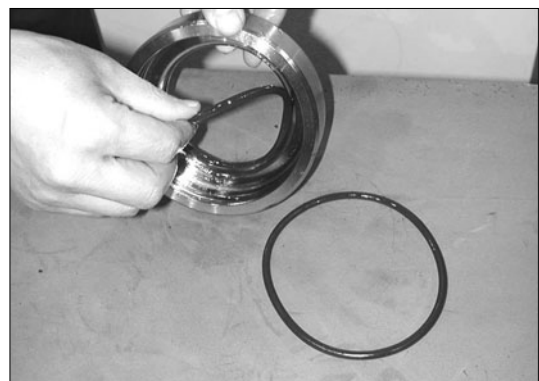

757AX20

Remove O-ring from cover assembly.

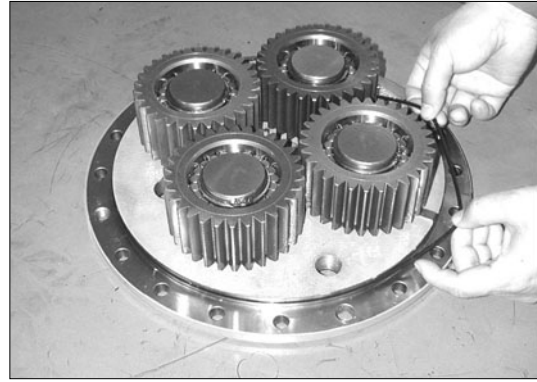

757AX21

## (2) ASSEMBLY

Insert the inner bearing cone.



757AX22

Press fitting lip seal.

Smear loctite 573 or equivalent sealant on outer diameter surface.



757AX23

Support suitably wheel hub while assembling parts to prevent damage of seal; then go on by fitting wheel bearing on hub spindle.

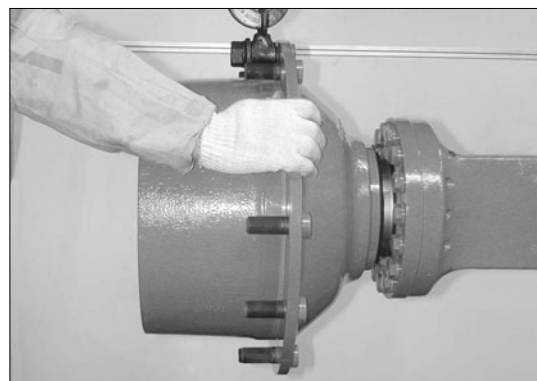

757AX24

Replace O-ring seals on piston.  
Cover the oil on O-ring seal enough.



757AX25

Insert piston full travel down on hub spindle.

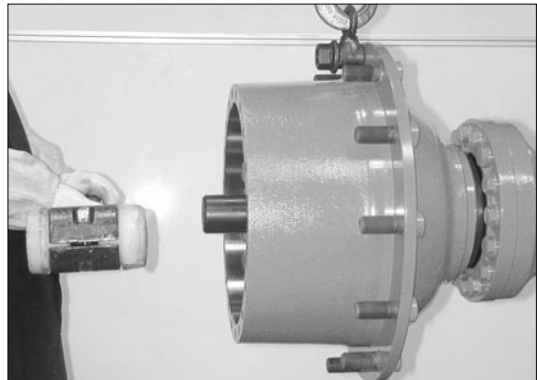

757AX26

Insert ring gear support in ring gear, then fit  
spring ring retaining axle.



757AX27

Mount on hub spindle the complete ring gear  
unit.  
Attention to the weight.



757AX28

Insert into relevant holes the six pins that, for proper operation of whole system, have to be of the same length and however in accordance with relevant drawing.

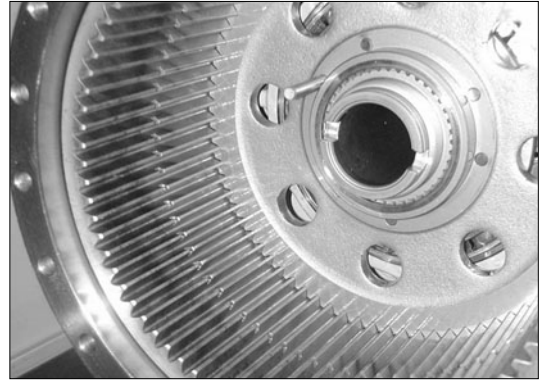

757AX29

Position return spring, cover and spacer on pressure plate, press compression tool.

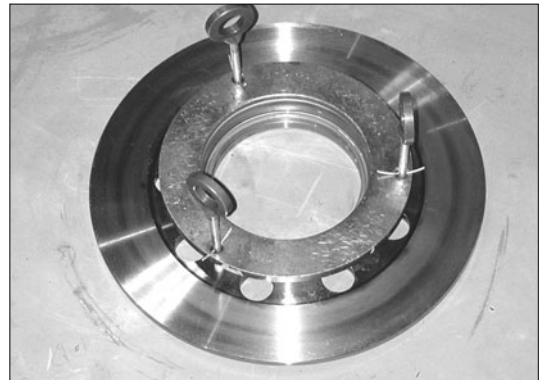

757AX30

Assemble support assembly with spring compression tool on spindle and tighten adjusting nut.

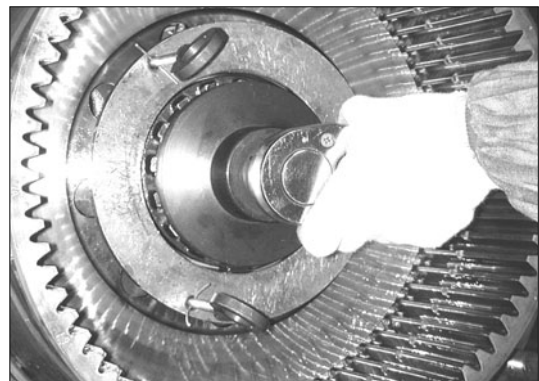

757AX31

With proper wrench lock ring so to reach the specified wheel bearing pre-load corresponding to a rotation torque and a rope pull strength on studs included into 15~18kg.

To prevent wrong torque recording, it is advisable to set bearings, by various wheel revolutions, prior performing the check.

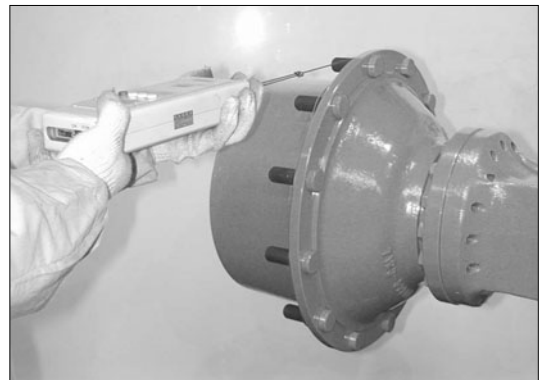

757AX32

Remove spring compression tool.

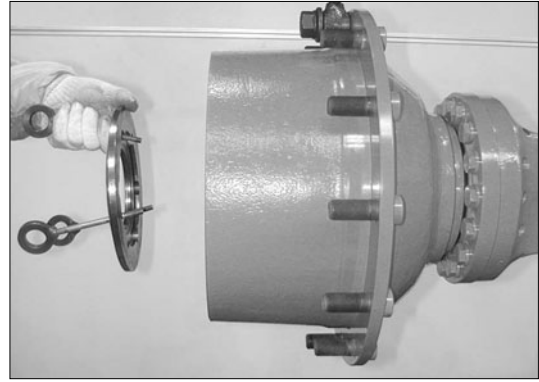

757AX33

Fit plate and assemble retain ring.

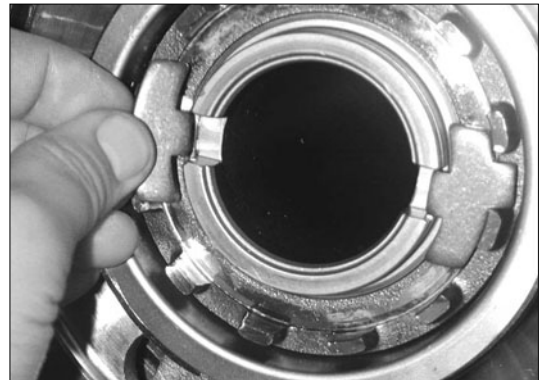

757AX34



757AX035

Assemble shaft assembly with drum and washer.

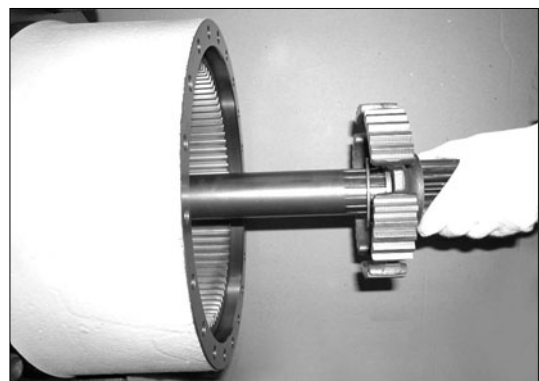

757AX036

Assemble disc pack according to the procedure.

Assembly procedure of brake disc pack :  
To hub drum from pressure plate **C, B, C, B.....C, B.**(C=disc-count, B=disc-brake)

Quantity of brake disc.

- Front axle : disc-count 4EA  
disc-brake 4EA
- Rear axle : disc-count 4EA  
disc-brake 4EA

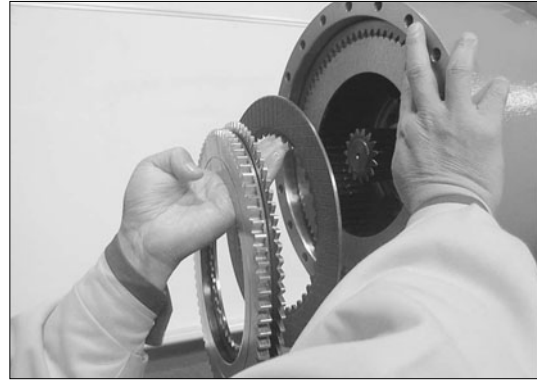

757AX37

Assemble brake plate.

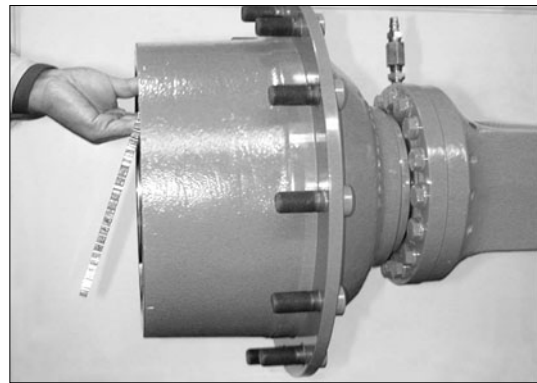

757AX38

Assemble retain ring.

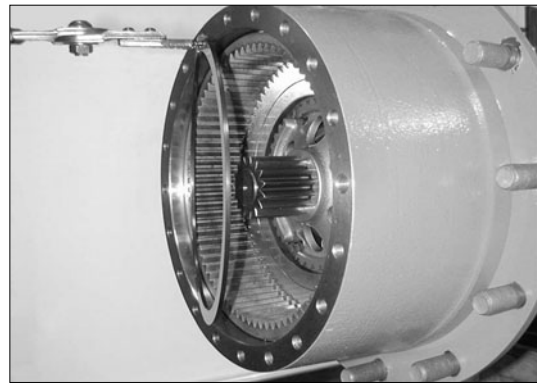

757AX39

Put the dial gauge vertically on the brake plate face.

After applying brake pressure, reset the dial gauge zero point.

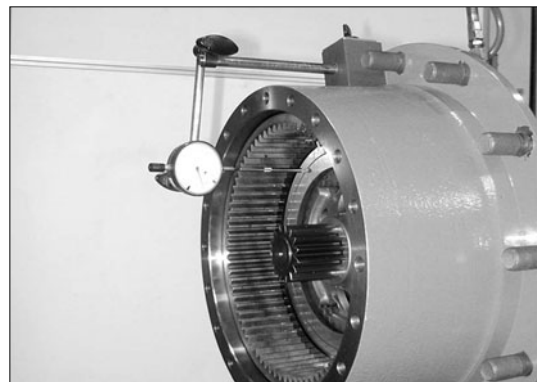

757AX40

Push the brake plate to the end and then read the dial gauge to confirm that the brake stroke satisfies the specification stroke.

Front axle : 3.8~4.2mm

Rear axle : 3.8~4.2mm



757AX41

Replace O-ring cover assembly.

Cover the oil on O-ring seal enough.

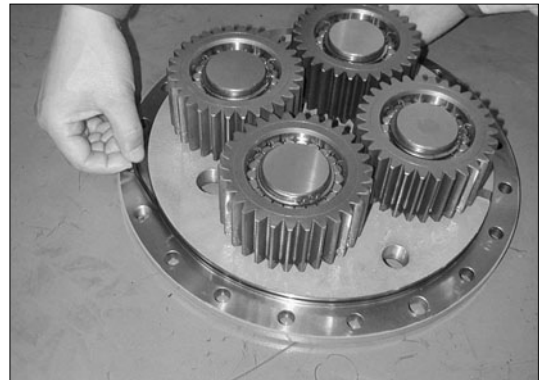

757AX42

) After aligning the drain hole and tab hole, assemble cover into wheel hub.

Make sure brake disc not to escape from drum.

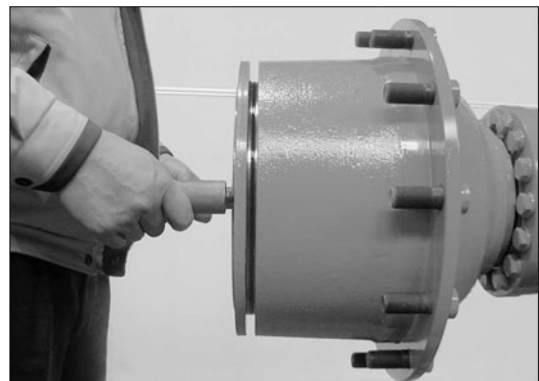

757AX43

) Tighten the screw for oil drain after applying sealant.

· Tightening torque(1EA) : 16.5~20kgf · m  
(119~145lbf · ft)



757AX44

- ) Tight the fixed bolt of cover assembly.
  - Tightening torque : 14.2~15.7kgf · m  
(103~114lbf · ft)

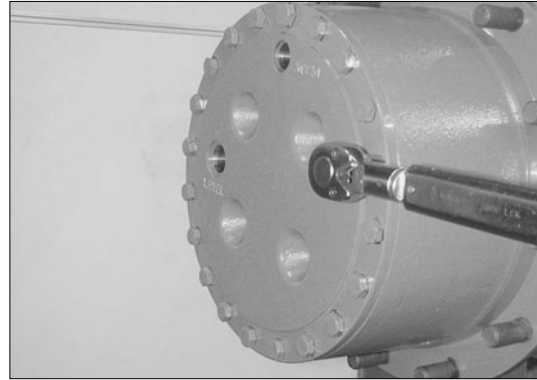

757AX45

### 3) PARKING BRAKE(FRONT AXLE ONLY)

#### (1) DISASSEMBLY

Insert through oil adding hole of gripper the pressure of 100~120bar, in order to obtain calipers release.

Remove the cover bolts of caliper.

- Brake port size : 7/16 -20UNF O-ring type



Front

7707AX022

Release nut and screw.

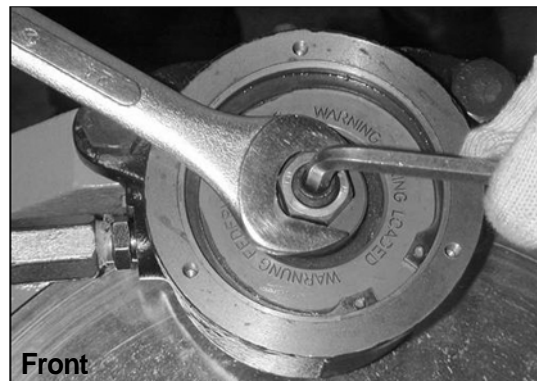

Front

7707AX023

Remove the split pin and nut of caliper brake. Remove the bolts.

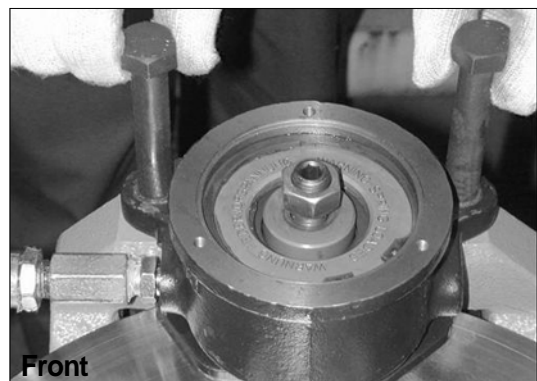

Front

7707AX024

Remove the caliper brake.

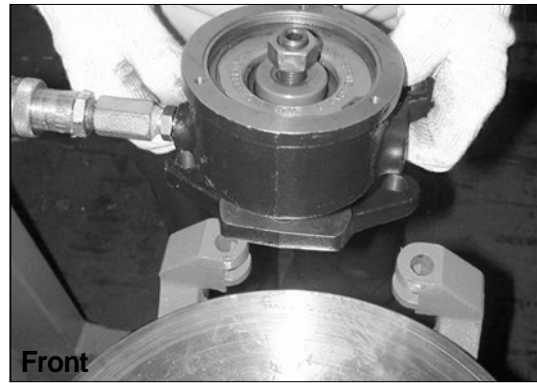

Remove the disc.

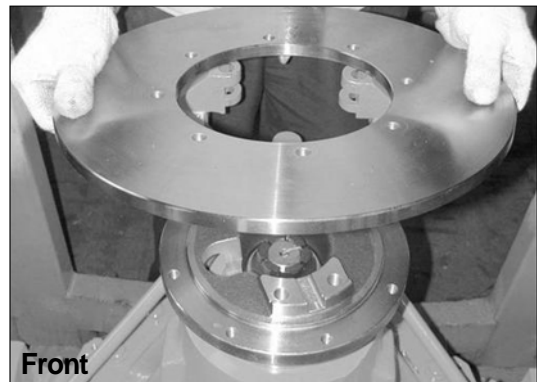

## (2) ASSEMBLY

Fit disc on flange, and tighten bolts.

- Tightening torque  
6~7kgf · m(43.4~50.6lbf · ft)

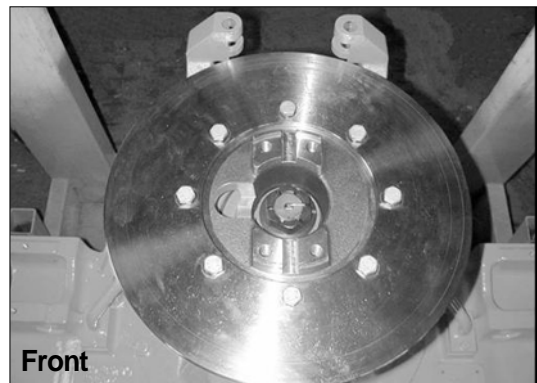

Remove cover and O-ring of caliper bracket,  
and release nut and pin screw.

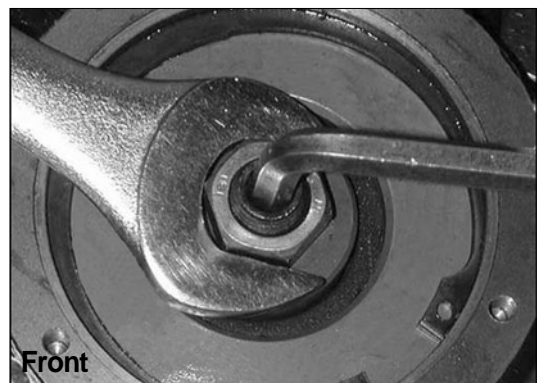

Release nuts on fixed bolts in order to obtain the maximum opening of gripper.

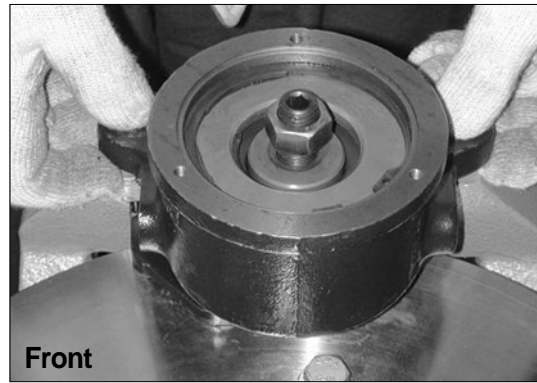

7707AX116

Insert fixed bolts on caliper bracket.

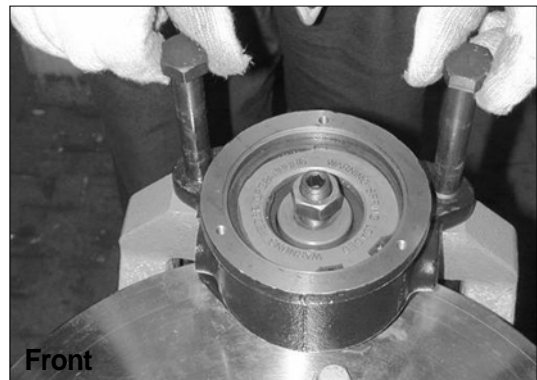

7707AX117

Tighten nuts and split pins.

- Tightening torque  
1~3kgf · m(7.2~21.7lb · ft)

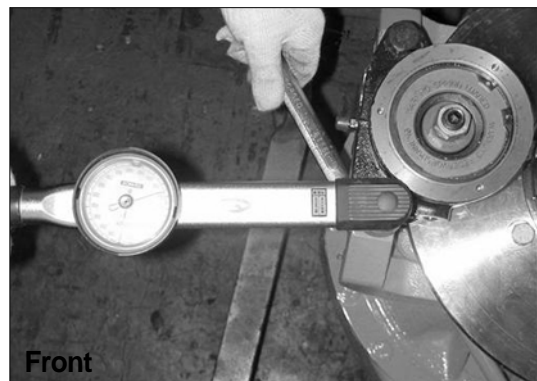

7707AX118

Assemble the bleeder on brake caliper.

- Bleeder tightening torque : 1.4~1.5Kgf · m  
(10.1~10.8lb · ft)

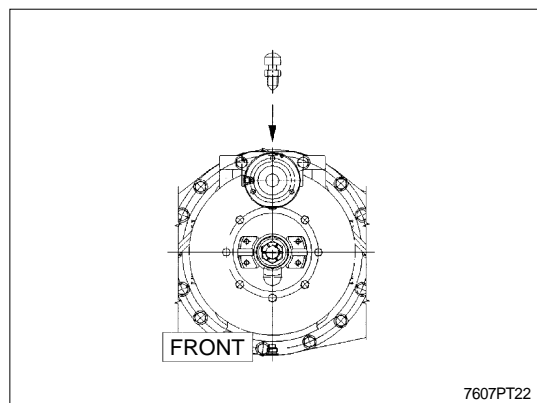

7607PT22

Press 110~120bar in brake port and close  
adhesion pad on disc by means of tightening  
screw pin.

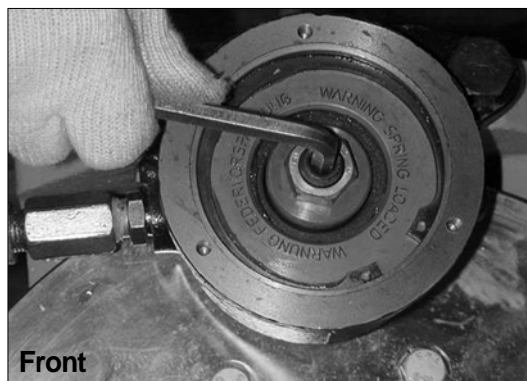

7707AX120

Check the gap between discs after unscrew-  
ing pin screw 1/8~1/4turn.

Disc gap : Each 0.125~0.25mm

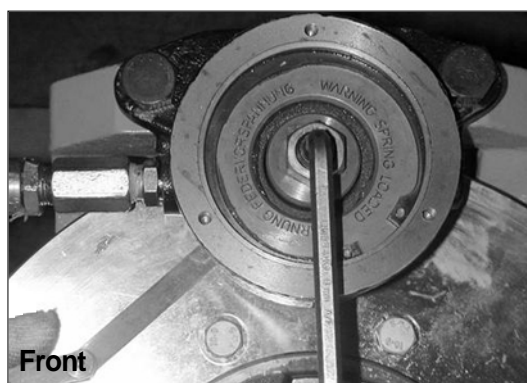

7707AX121

Tighten nut.

- Tightening torque : 14~16kgf · m  
(101~116lbf · ft)

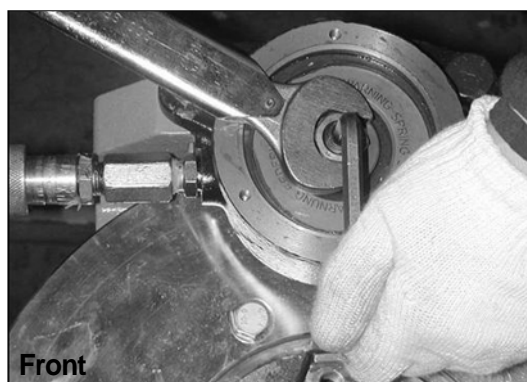

7707AX122

Tighten bolts after assembling O-ring on cover.

- Tightening torque : 1.3~1.5kgf · m  
(9.4~10.8lbf · ft)

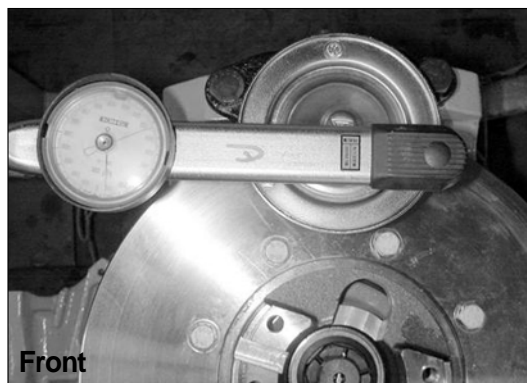

7707AX123

#### 4) DIFFERENTIAL ASSEMBLY

##### (1) REMOVAL

Loosen the screws retaining differential group, then remove it from axle case.

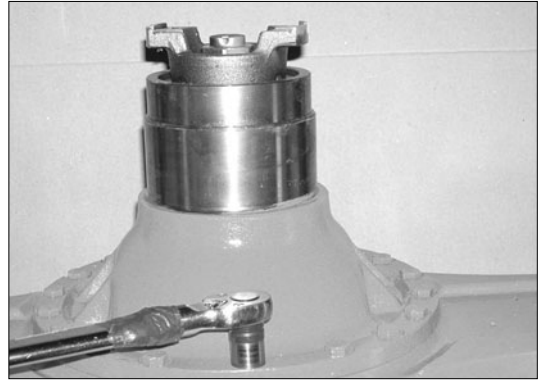

757AX46

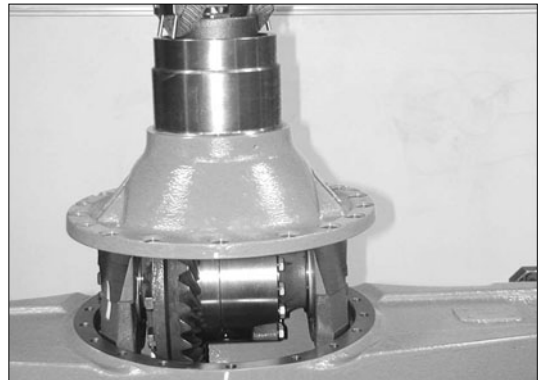

757AX47

##### (2) DISASSEMBLY

Place differential unit upside down; mark caps position.

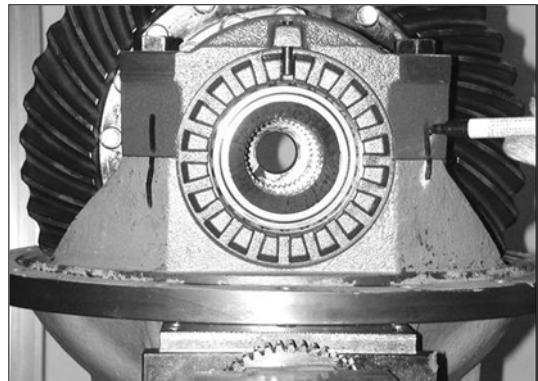

7707AX031

Unlock and remove caps fixing screws.

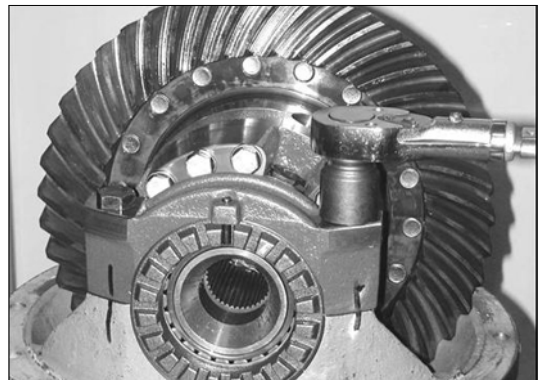

7707AX032

Remove lock pin of ring nut, remove caps.

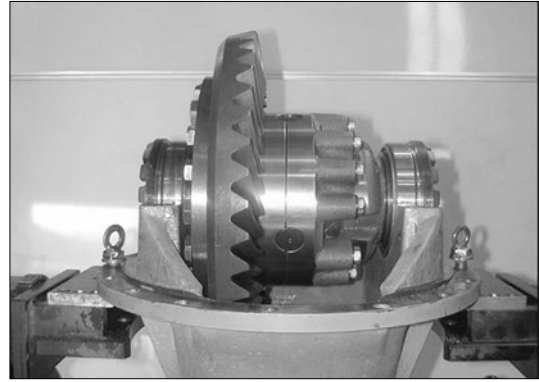

7707AX033

Lift up differential and cross beam assembly from support, by a lifting tool with proper capacity.

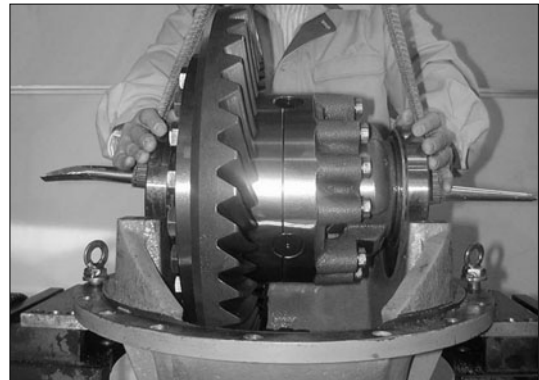

757AX48

Put the carrier upright and then spread the caulked parts with a proper tool.



757AX49

Remove pinion nut.

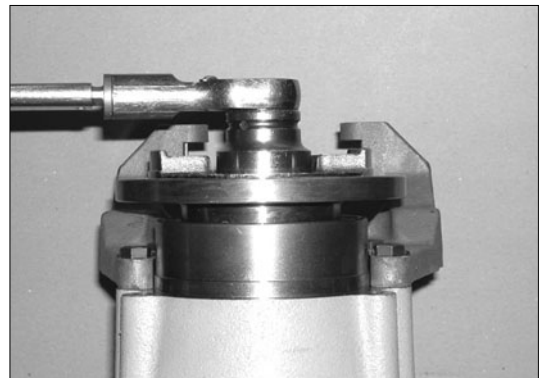

757AX50

Remove pinion nut and holder.

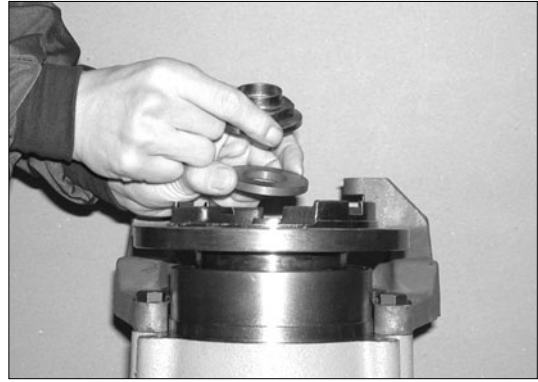

757AX51

Remove flange assembly.



757AX52

Loosen caliper bracket fixing bolts and  
remove caliper bracket.  
(Front differential only)

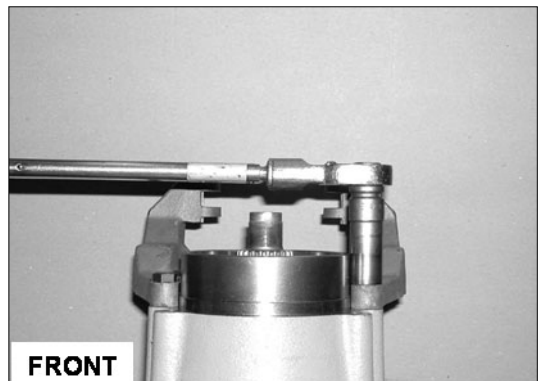

757AX53

Pry off seal from P.T.O. flange.



7707AX037

Drive out bevel pinion from differential support hammering by a proper remover on shank, don't damage thread.

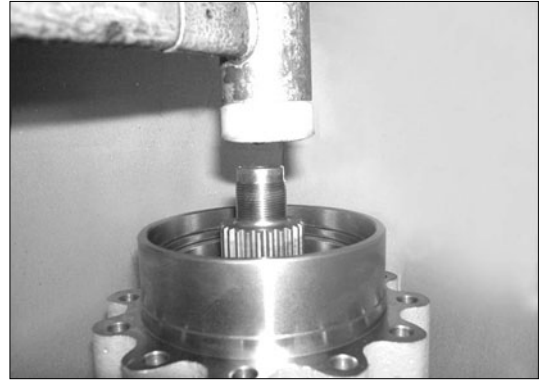

Remove the bearing cone.



Remove the shim and spacer in removed pinion.



Remove shim and bearing cup from differential support, hammer pinion shank by a proper tool, taking care not to damage thread.



### (3) ASSEMBLY

Measure the dimensions for assembly position of pinion bevel.

Decide the dimension X(shim thickness) by the calculation.

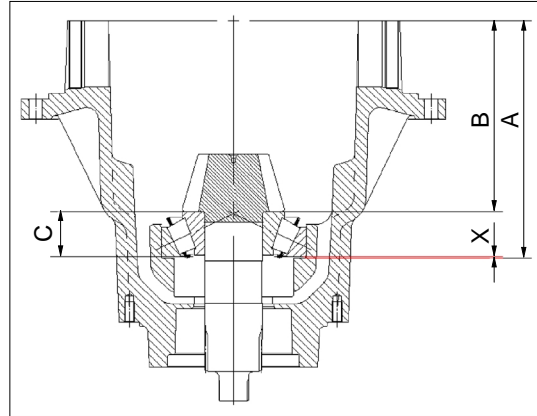

7707AX043

Both the bevel pinion and the bevel gear are marked with a number. Confirmed the some numbers both the pinion-bevel and gear-bevel.

Number location of bevel set

Bevel pinion : Head surface

Bevel ring : Outer cutting side



757AX73

Measure the carrier height **A** by the special tool.

Standard value of **A**

- Front axle : 210mm
- Rear axle : 203mm

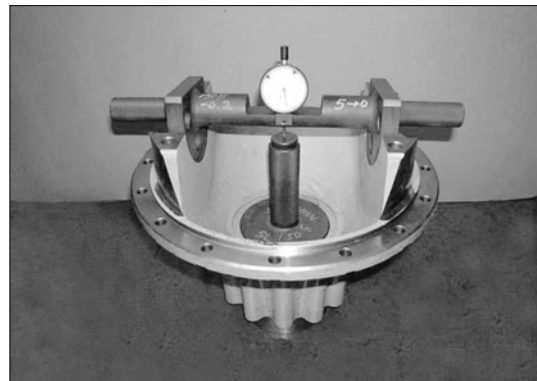

757AX57

Decide a value **B** by the carved value of bevel pinion head.

- Front axle :  $B = 165 \pm \text{carved value}$
- Rear axle :  $B = 158 \pm \text{carved value}$

In case, the carved value is -10, **B** of

Front axle =  $165 - 0.1 = 164.9\text{mm}$

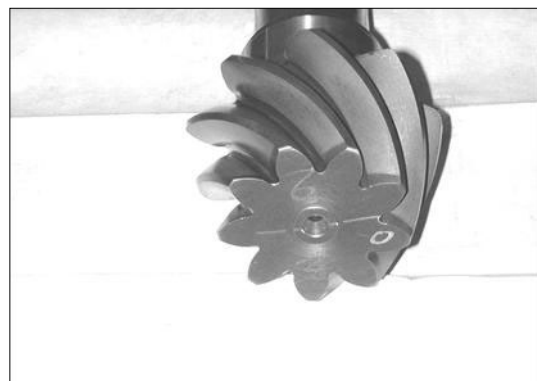

757AX74

Measure the width of bearing **C**.

Standard value of **C**

- Front axle : 44.45mm
- Rear axle : 44.45mm

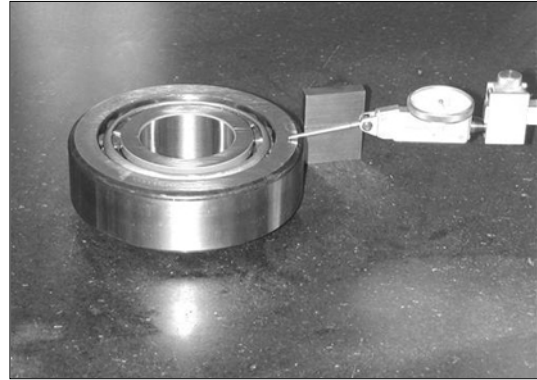

7707AX047

Determine shim X thickness for correct axial position of pinion-bevel.

$$X = A - (B + C)$$

Round up or down to the nearest tenth of millimeter the computed thickness.

2.12 rounded down to = 2.1mm

2.18 rounded up to =2.2mm

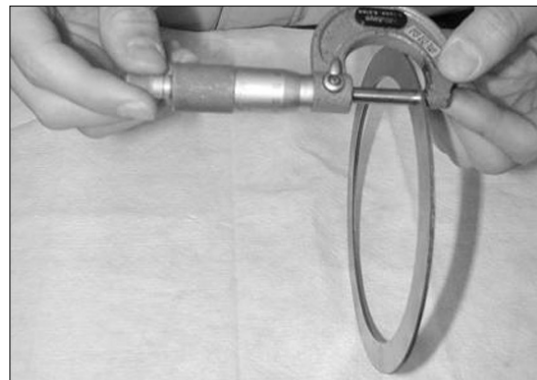

7707AX144

Insert adjustment shim for axial position of pinion.

Its value was computed previously ; also, fit outer races of pinion under head and shank bearings.

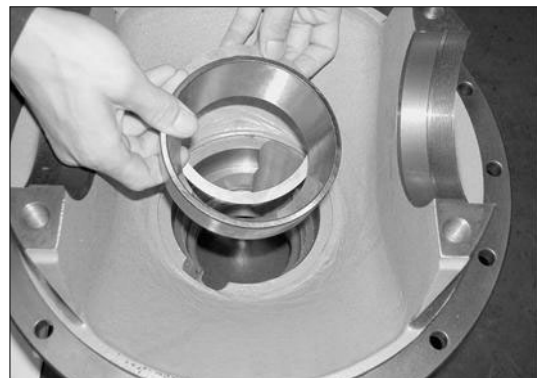

757AX75

Fit in pinion shank inner race of under head bearing, heat or press-in part by installer.



757AX58

Assemble the spacer and shims(2EA).

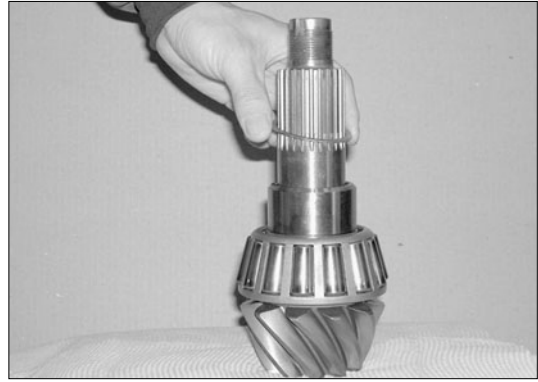

757AX59

Turn the carrier upside down and assemble the bevel pinion assembly.

In order to contact between the bearing cone in pinion bevel and the cup bearing of carrier perfectly, support the bevel pinion by preferable tool.

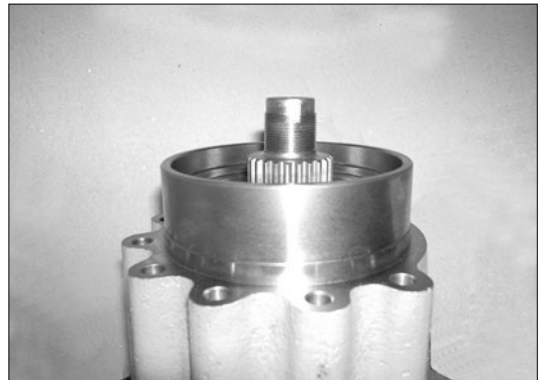

757AX60

Fit in cone bearing by heating or pressing.

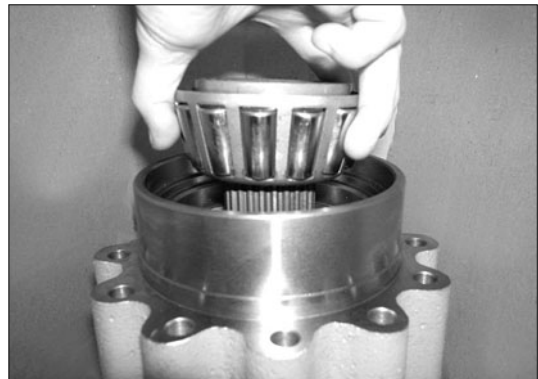

757AX61

Assemble dust seal by pressing.

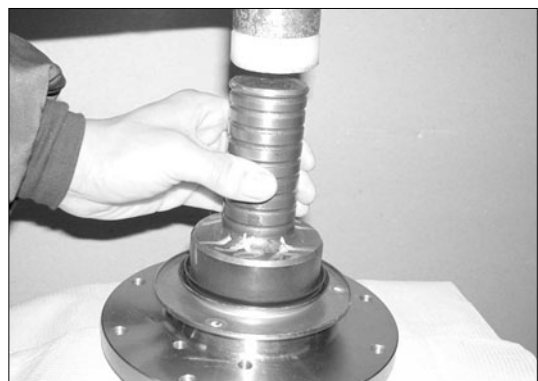

757AX62

Assemble flange and holder in bevel pinion, and tighten pinion nut.

Don't assemble seal.

- Tightening torque : 58~64kgf · m  
(420~463lb · ft)



757AX63

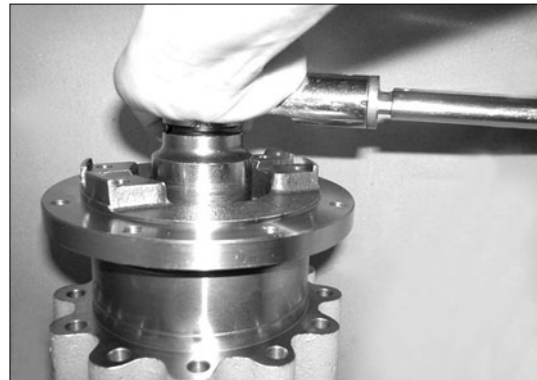

757AX64

Measure preload and confirm the follow value.

Bearing preload

- Front axle : 0.2~0.4kgf · m
- Rear axle : 0.2~0.4kgf · m

Before measuring preload, rotate two or three times. Disassemble and change adjustment shims to eliminate all end play up to reach a pre-load. (Front axle)

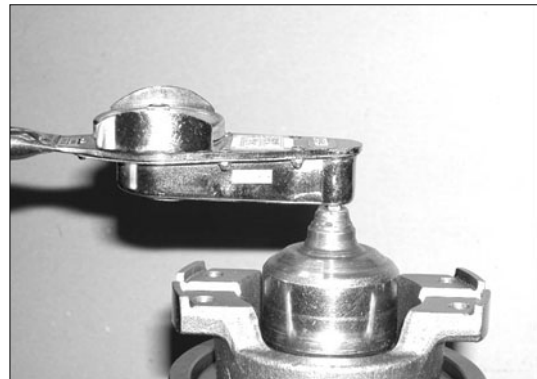

757AX65

As bearing pre-load has been determined, remove drive flange and pinion nut holder.

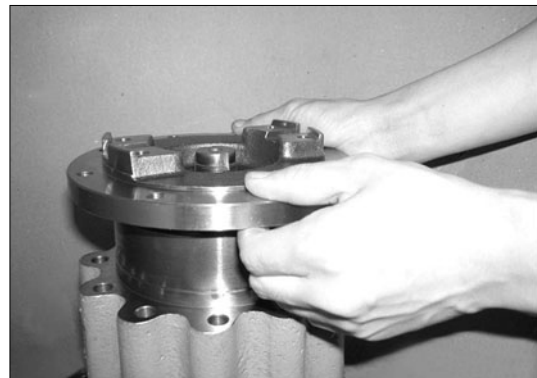

757AX66

Assemble seal.

Cover the seal with retaining compound.  
Cover the seal lip and the flange with oil.

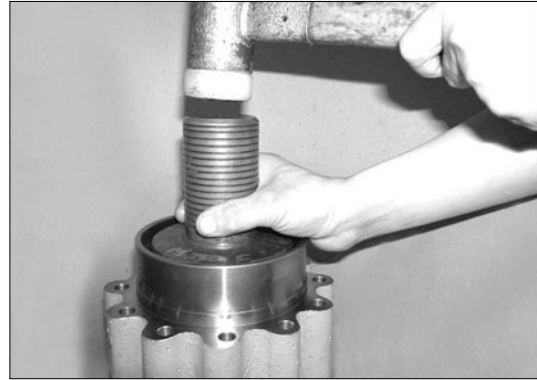

757AX67

Fit caliper bracket and tighten bolts.

- Tightening torque : 14.2~15.7kgf · m  
(103~113lb · ft)

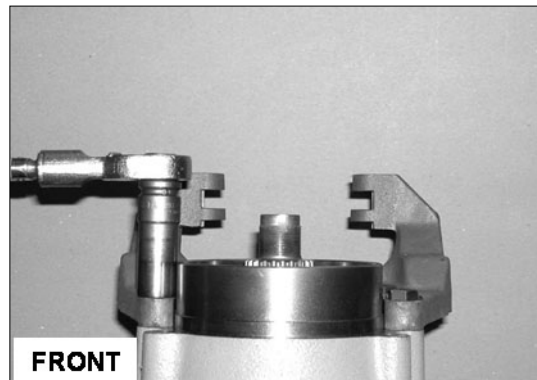

757AX68

Assemble flange assembly.

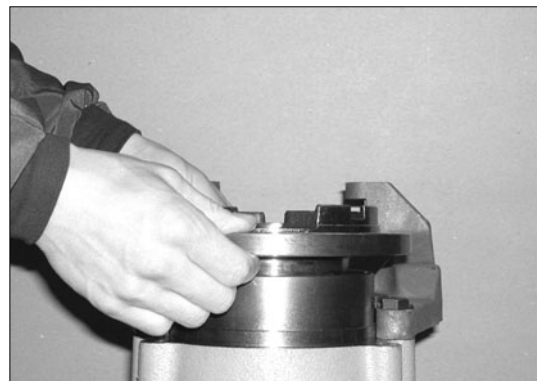

757AX69

Tighten pinion nut.

- Tightening torque : 58~64kgf · m  
(420~463lb · ft)

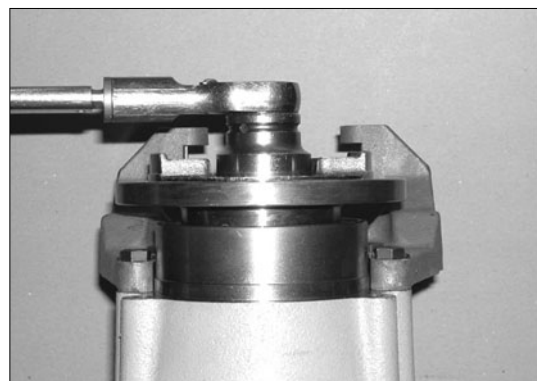

757AX70

Assemble bevel pinion and thghten the pinion nut and the split pin.(2EA)

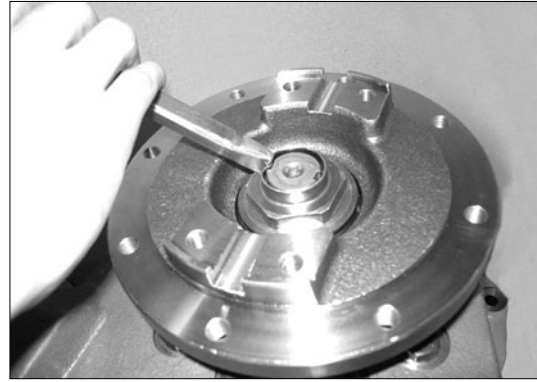

757AX71

- ) Fit in the differential assembly on the carrier, and assemble adjusting nut temporarily.

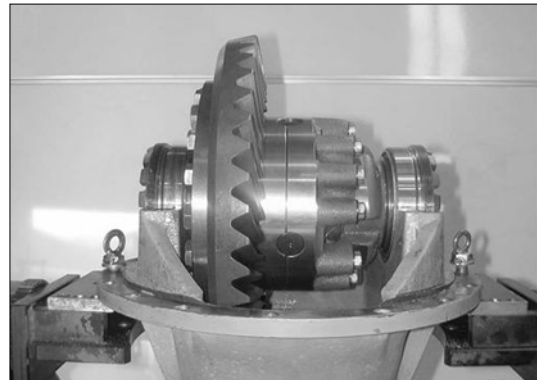

7707AX061

- ) Install caps, care not to reverse position and lock screws fixing to differential support with belows.

Cap tightening torque :

31.3~34.6kgf · m(226~250lbf · ft)

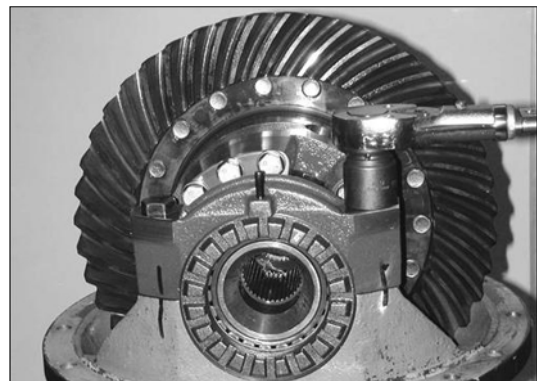

7707AX062

- ) Position a dial gauge perpendicular than ring gear tooth and check, with pinion steady, backlash that has to be of 0.20~0.28mm. Otherwise rotate both ring nuts by displacing them of the same number of notches and nearing ring gear to pinion if backlash is excessive, by moving away on the contrary.

Bevel set back lash : 0.20~0.28mm

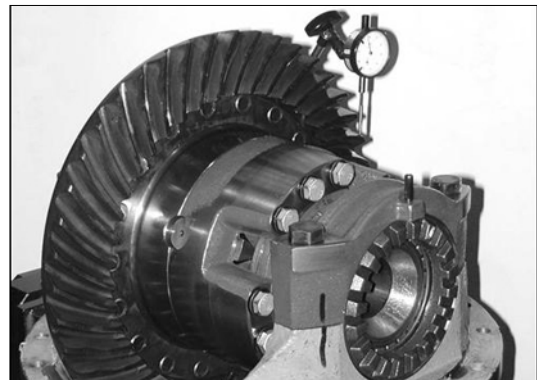

7707AX063

) Brush red lead on some ring tooth, rotate to mesh pinion and ring gear repeatedly, so to make evident tooth contact. Proper and correct tooth contact marks are visible on a new bevel gear set as a result of an optimum contact approached on the tester, consequently, a proper axial position of pinion against ring gear will emphasise remarking of previous tester contact markings.

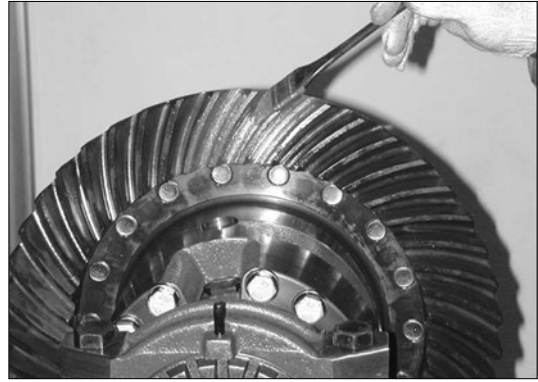

7707AX064

) Fit spring pins locking threaded rings of differential unit.

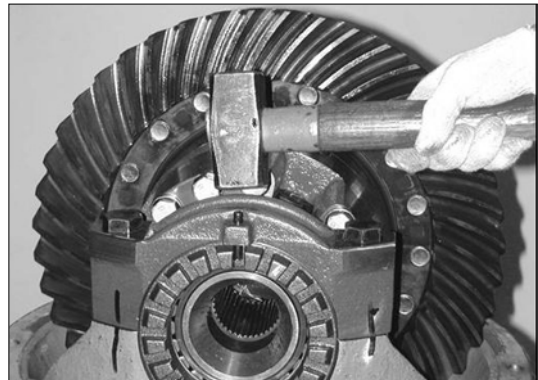

7707AX065

#### 4) SUPER MAX TRAC

##### (1) DISASSEMBLY

Mark the two half cases(LH/RH).



7607AX154

Loosen the bolts of the case(RH) and remove the case(RH).



7607AX155

Remove the side gear and the thrust washer.

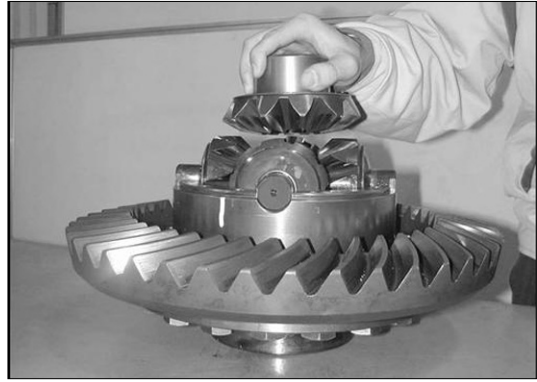

7607AX156

Remove spider with the four side gears and relevant bevel thrust washers.



7607AX157

Remove the planetary gear with relevant intermediate and shim discs and clutch discs, in half case on bevel gear side.



7607AX158

Loosen bevel gear fixing screws.



7607AX159

## (2) ASSEMBLY

Install gear-bevel on case(LH) by bolts.

Tightening torque :

31.3~34.6kgf · m(226~250lbf · ft)



7607AX160

Insert side gear assembly and thrust washer in case(LH).

Assemble spider and side gear according to procedure.



7707AX079

Mount the cover, taking care to align the reference marked done before disassembling ; close the two half casings.

Screw in fixing screws and lock a torque of ;

- Front axle : 11.4~12.6kgf · m  
(82.5~91.1lbf · ft)
- Rear axle : 5.8~7.2kgf · m  
(42~52lbf · ft)



7607AX162

**5) TOOLS**

Spring compression tool.

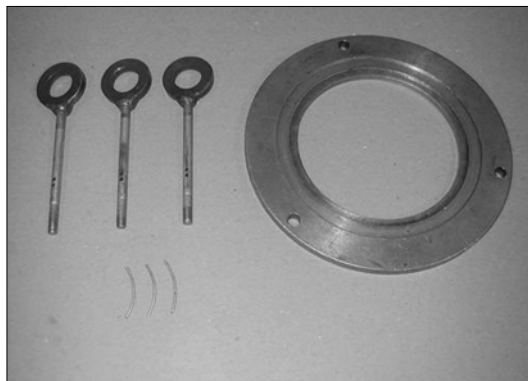

7707AX124

Nut adjusting tool of reduction assembly.

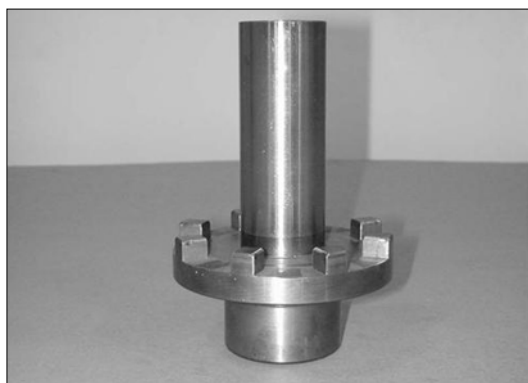

7707AX125

Cover assembly tool.

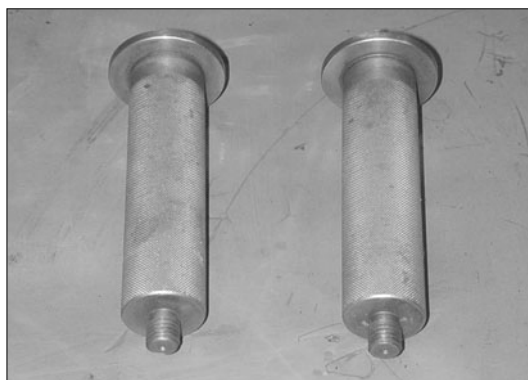

757AX72