

SECTION 4 BRAKE SYSTEM

Group 1 Structure and Function	4-1
Group 2 Operational Checks and Troubleshooting	4-21
Group 3 Tests and Adjustments	4-28
Group 4 Disassembly and Assembly	4-31

SECTION 4 BRAKE SYSTEM

GROUP 1 STRUCTURE AND FUNCTION

1. OUTLINE

- ※ The brakes are operated by a pressure compensated, closed center hydraulic system.
Flow is supplied by a fixed displacement, gear type brake pump.

BRAKE SYSTEM

The fixed displacement brake pump supplies flow to the cut-off valve for service brake circuit and park brake circuits. It flows to three accumulator. The accumulator has a gas precharge and an inlet check valve to maintain a pressurized volume of oil for reserve brake applications.

Oil through the accumulator flows to the brake valves. The brake valve is a closed center design, dual circuit operated by a pedal.

The front and rear brakes will operate simultaneously with only one brake pedal depressed.

The differential contains annular brake piston and double sided disk.

Main pump flow through the main control valve goes to the parking brake solenoid valve in cut-off valve.

The brake system contains the following components:

- Brake pump
- Parking brake solenoid valve in cut-off valve
- Cut-off valve
- Brake valve
- Accumulators
- Pressure switches

FULL POWER HYDRAULIC BRAKE SYSTEM

ADVANTAGES - The full power hydraulic brake system has several advantages over traditional brake actuation systems. These systems are capable of supplying fluid to a range of very small and large volume service brakes with actuation that is faster than air brake systems. Figure represents a time comparison between a typical air/hydraulic and full power hydraulic brake actuation system.

Full power systems can supply significantly higher brake pressures with relatively low reactive pedal forces. The reactive pedal force felt by the operator will be proportional to the brake line pressure being generated. This is referred to as brake pressure modulation.

Another key design feature of full power systems is the ability to control maximum brake line pressure. In addition, because these systems operate with hydraulic oil, filtration can be utilized to provide long component life and low maintenance operation.

Because these systems are closed center, by using a properly sized accumulator, emergency power-off braking that is identical to power-on braking can be achieved. These systems can be either dedicated, where the brake system pump supplies only the demands of the brake system or non-dedicated, where the pump supplies the demands of the brake system as well as some secondary down stream hydraulic device.

Another important note is that all seals within these system must be compatible with the fluid medium being used.

**Response time
Full power brake actuation VS
Air/Hydraulic brake actuation**

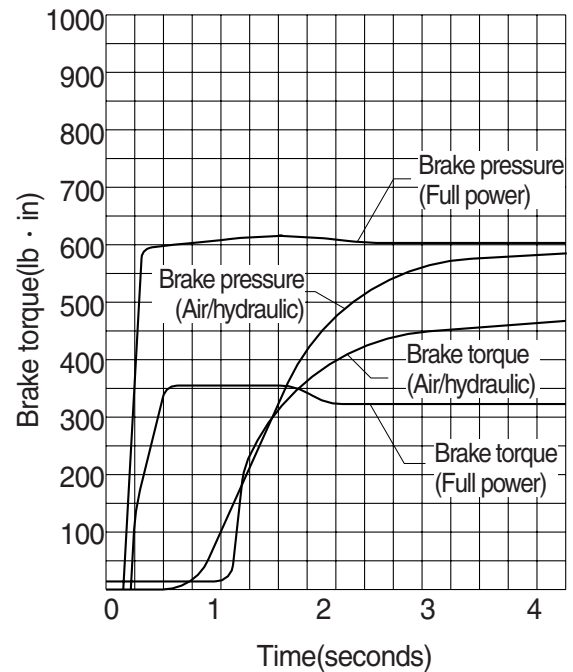

2. HYDRAULIC CIRCUIT

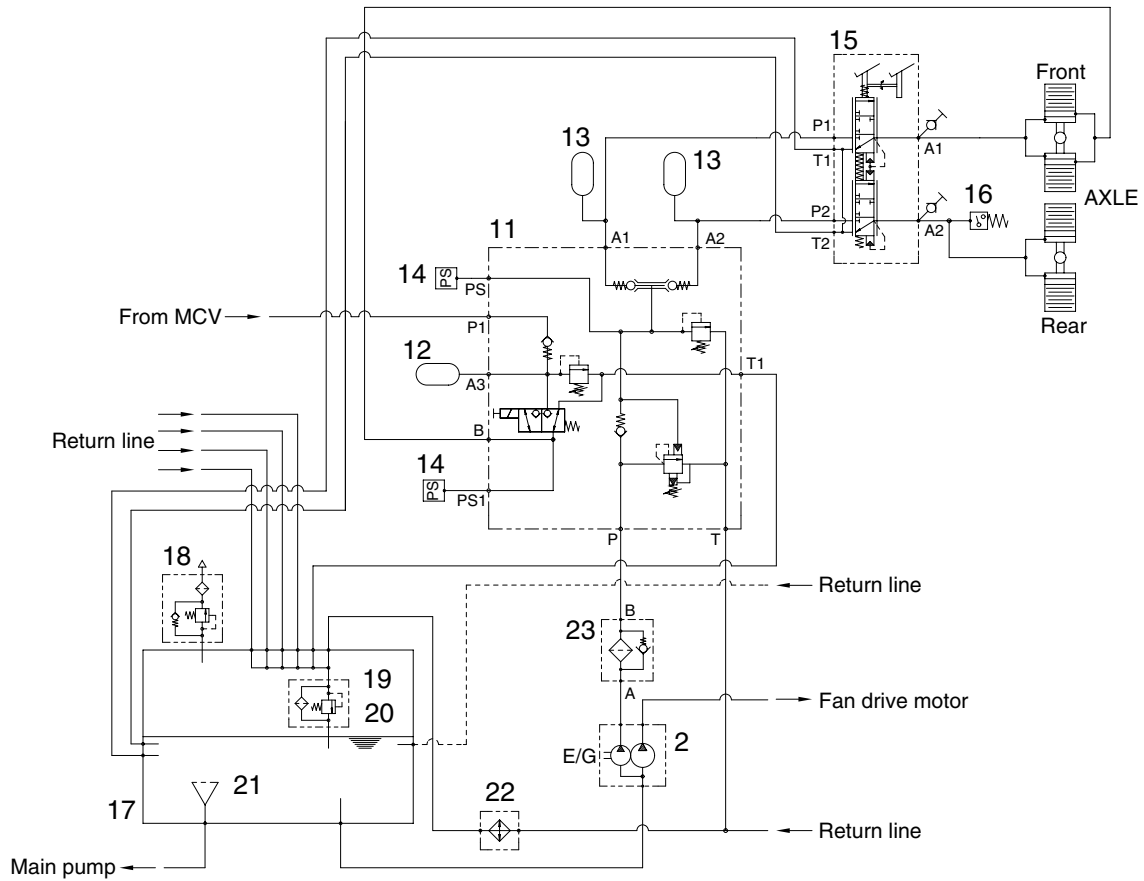

74094BS01

- | | | | | | |
|----|------------------|----|-----------------|----|-----------------|
| 2 | Fan & brake pump | 15 | Brake valve | 20 | Bypass valve |
| 11 | Cut off valve | 16 | Pressure switch | 21 | Strainer |
| 12 | Accumulator | 17 | Hydraulic tank | 22 | Oil cooler |
| 13 | Accumulator | 18 | Air breather | 23 | Pressure filter |
| 14 | Pressure switch | 19 | Return filter | | |

1) SERVICE BRAKE RELEASED

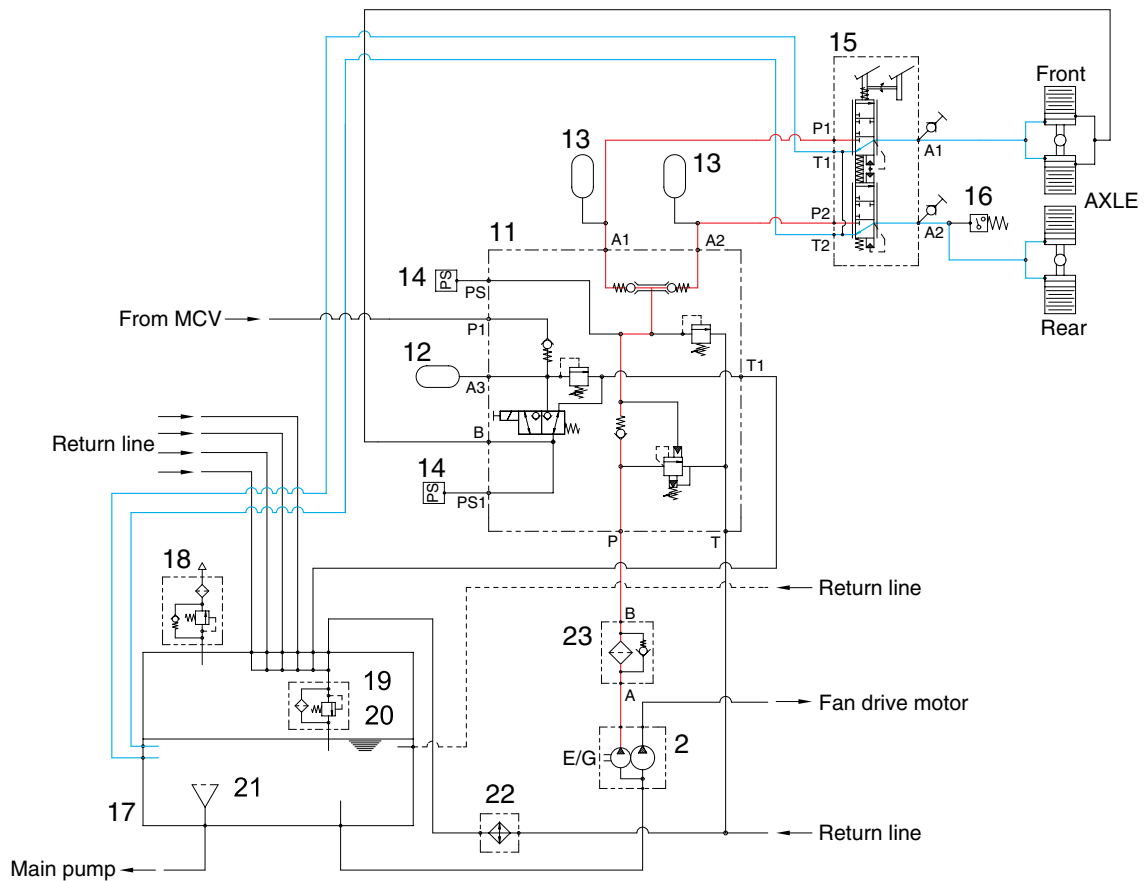

74094BS02

When the pedal of brake valve (15) is released, the operating force is eliminated by the force of the spring, and the spool is returned.

When the spool removes up, the drain port is opened and the hydraulic oil in the piston of axles return to the tank (17).

Therefore, the service brake is kept released.

2) SERVICE BRAKE OPERATED

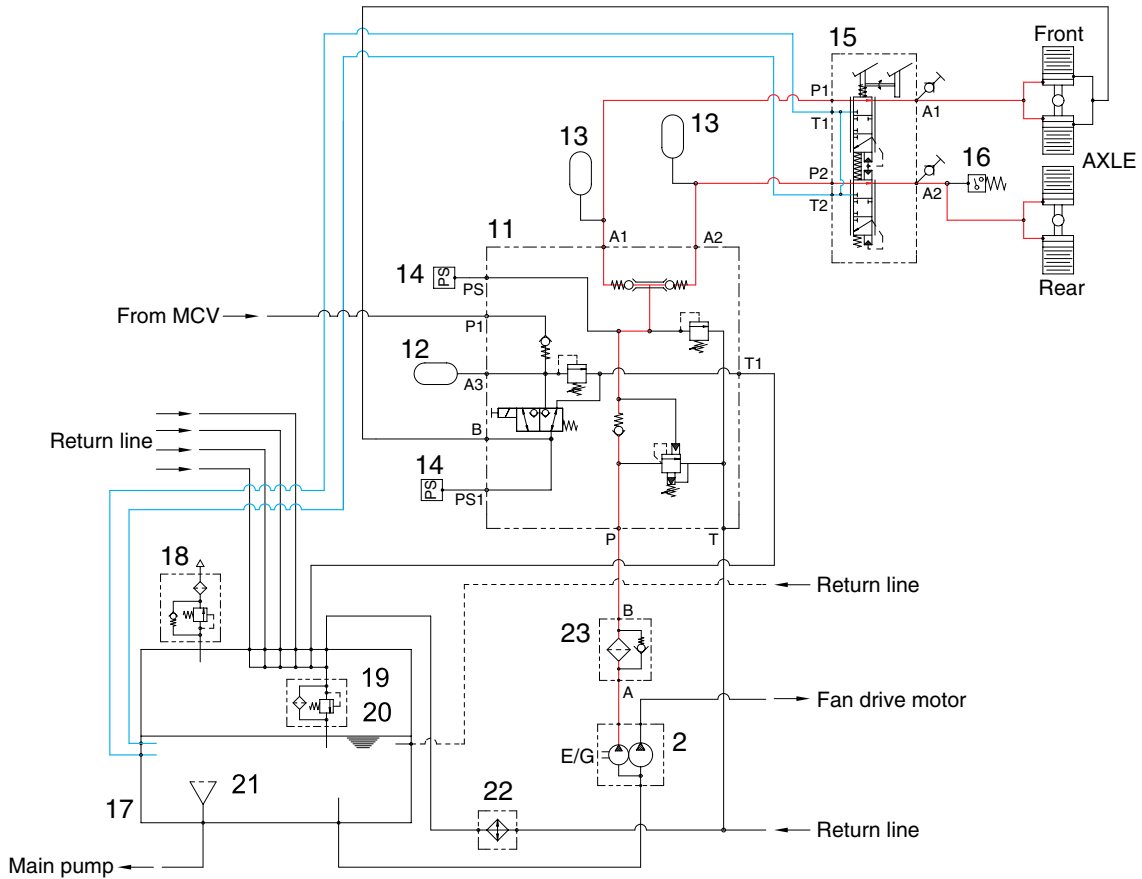

74094BS03

When the pedal of brake valve (15) is depressed, the operating force overcomes the force of the spring, and is transmitted to the spool. When the spool moves down, the inlet port is opened, and at the same time the hydraulic oil controlled the pressure level by the cut-off valve (11) enters the piston in the front and rear axles. Therefore, the service brake is applied.

3) PARKING BRAKE RELEASED

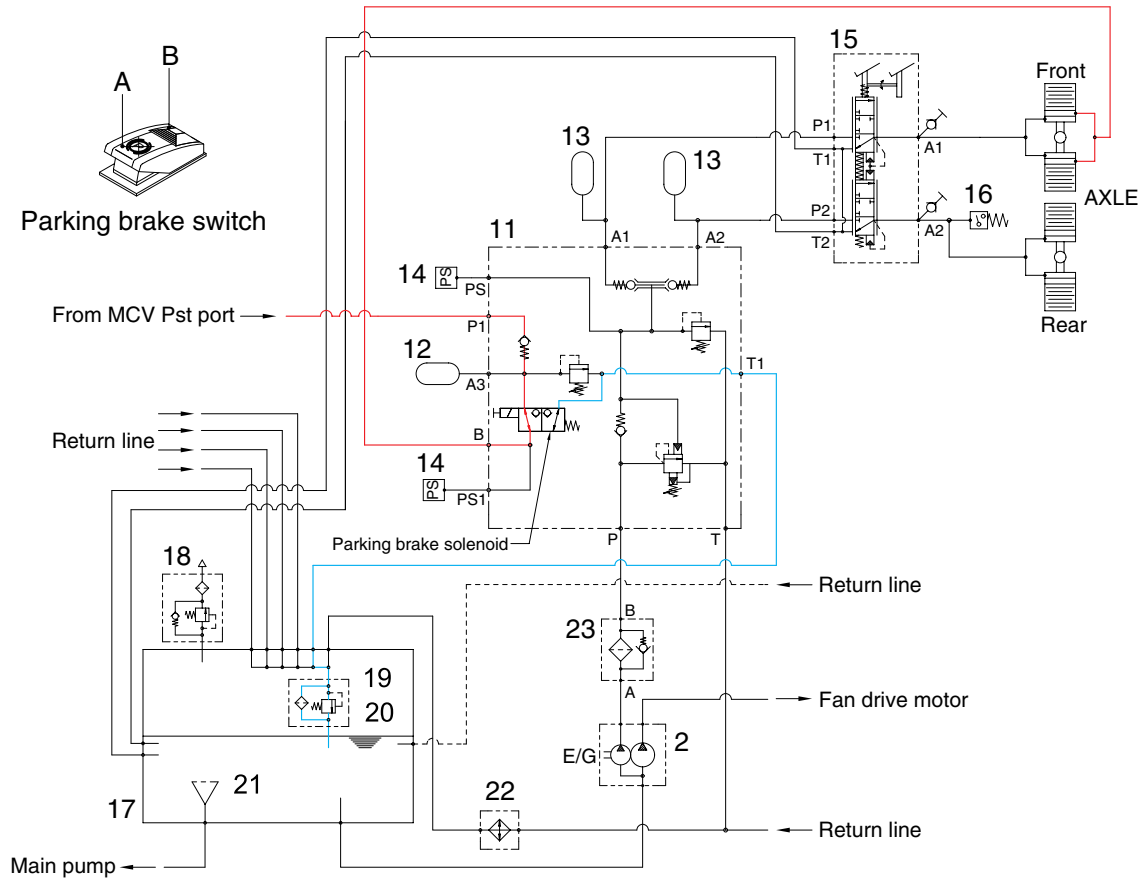

74094BS04

When the parking brake switch is pressed A position, the solenoid valve is energized and the hydraulic oil enters the front axle. It overcomes the force of the spring and pushes the piston rod. This releases the parking brake. Therefore, the hydraulic oil pressure is applied to the parking brake piston in front axle through the solenoid valve and the parking brake is kept released.

4) PARKING BRAKE OPERATED

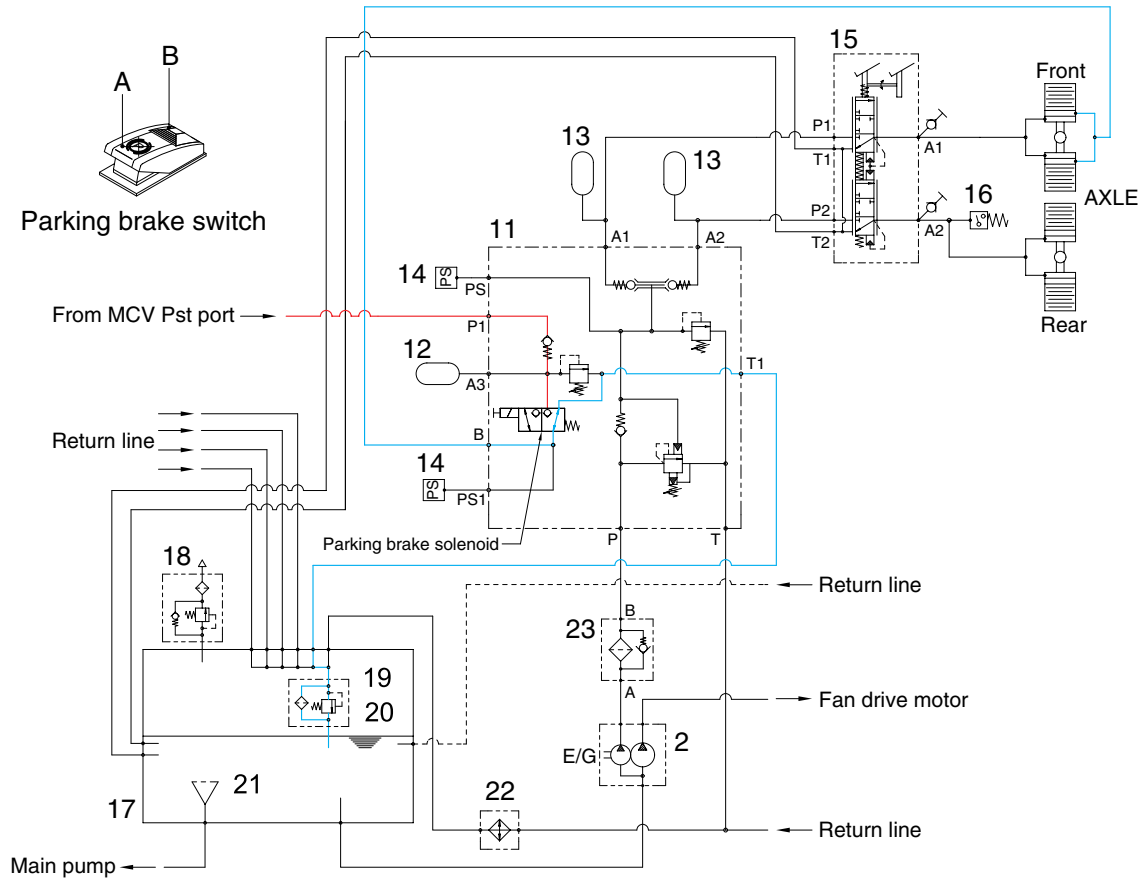

74094BS05

When the parking brake switch is pressed B position, the solenoid valve is deenergized and the valve open the drain port.

At the same time, the hydraulic oil in the parking brake return to the tank through the solenoid valve. When the piston rod is returned by the force of the spring, the parking brake is applied.

3. BRAKE PUMP (+FAN PUMP)

1) STRUCTURE

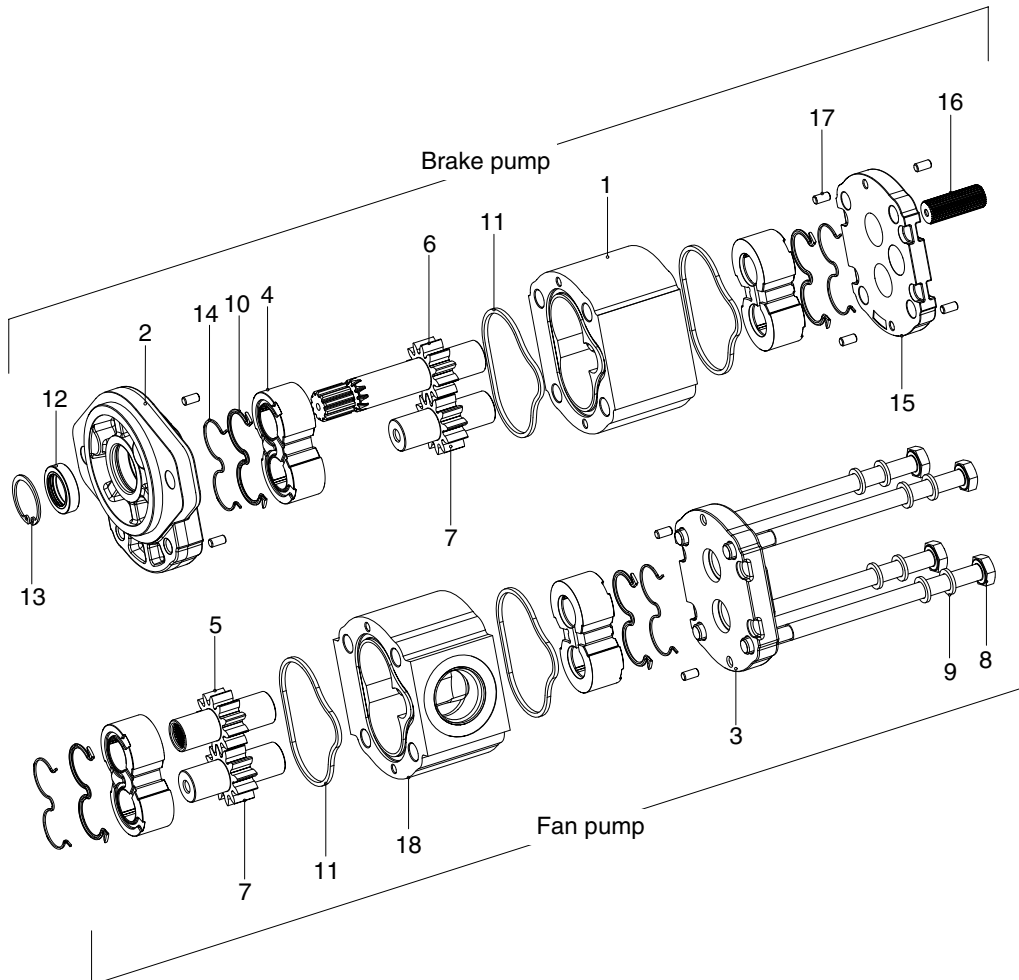

74094BS20

1	Housing	7	Driven gear	13	Ring
2	Front cover	8	Bolt	14	Backing ring
3	Rear cover	9	Washer	15	Flange
4	Thrust plate	10	Seal	16	Splined shaft
5	Drive gear	11	Seal	17	Dowel pin
6	Drive shaft	12	Shaft seal	18	Housing

This gear pump have a maximum delivery pressure of 150 kgf/cm².

The pressure loaded type gear pump is designed so that the clearance between the gear and the bushing can be automatically adjusted according to the delivery pressure. Therefore, the oil leakage from the bushing is less than that in the case of the fixed bushing type under a high discharge pressure. Consequently, no significant reduction of the pump delivery occurs, even when the pump is operated under pressure.

2) PRINCIPLE OF OPERATION

(1) Mechanism for delivering oil

The drawing at right shows the operational principle of an external gear pump in which two gears are rotating in mesh.

The oil entering through the suction port is trapped in the space between two gear teeth, and is delivered to the discharge port as the gear rotates.

Except for the oil at the bottom of the gear teeth, the oil trapped between the gear teeth, is prevented from returning to the suction side with the gears in mesh.

Since the gears are constantly delivering oil, the oil delivered to the discharge port is forced out of the port.

The amount of discharge increases with the speed of rotation of the gear.

If there is no resistance in the oil passage into which the discharged oil flows, the oil merely flows through the passage, producing no increase in pressure.

If however, the oil passage is blocked with something like a hydraulic cylinder, there will be no other place for the oil to flow, so the oil pressure will rise. But the pressure which rises in this way will never go higher, once the hydraulic cylinder piston starts moving because of the oil pressure.

As described earlier, the pump produces the oil flow, but not the oil pressure. We can therefore conclude that pressure is a consequence of load.

In other words, the pressure depends on a counterpart.

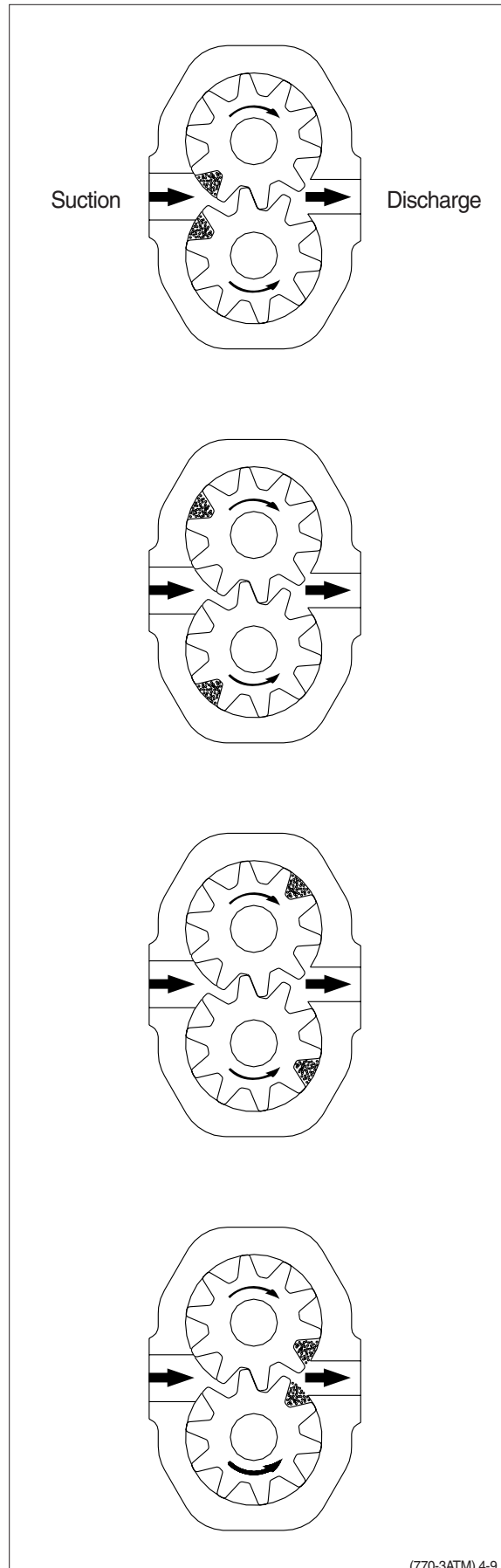

(2) Internal oil leakage

Oil leaks from a place under higher pressure to a place under lower pressure, provided that a gap or a clearance exists in between.

In the gear pump, small clearances are provided between the gear and the case and between the gear and the side plate to allow the oil to leak out and to serve as a lubricant so that the pump will be protected from seizure and binding.

The drawing at right shows how the leaked oil flows in the pump. As such, there is always oil leakage in the pump from the discharge side (under higher pressure) to the suction side. The delivery of the pump is reduced by an amount equal to the pump discharge.

In addition, the delivery of the pump will also decrease as the amount of oil leakage increases because of expanded radial clearance resulting from the wear of pump parts, the lower oil viscosity resulting from increases in the oil temperature, and the initial use of low viscosity oil.

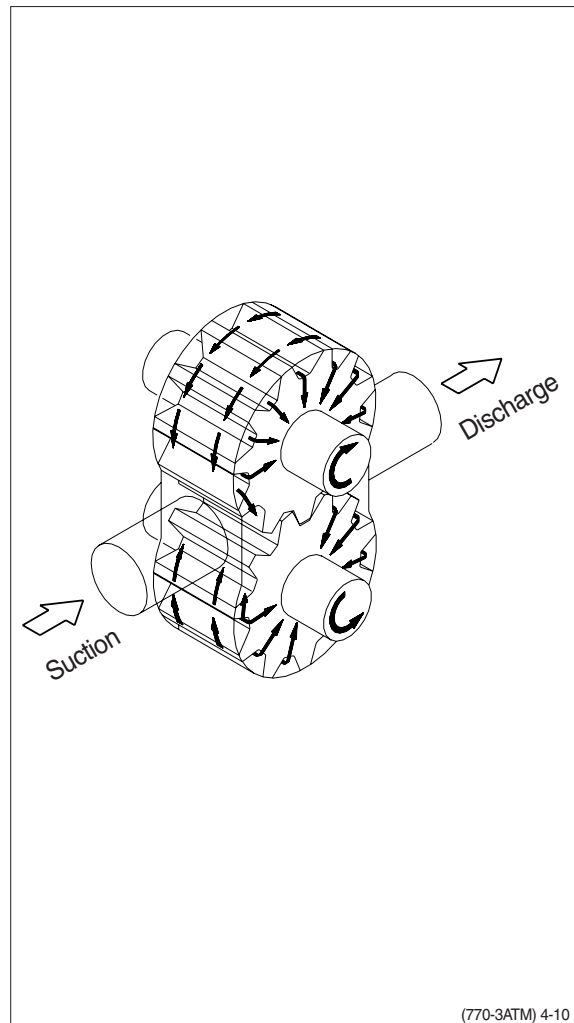

(3) Forces acting on the gear

The gear, whose outer surface is subjected to oil pressure, receives forces jointing towards its center.

Due to the action of the delivery pressure, the oil pressure is higher on the delivery side of the pump, and due to suction pressure, is lower on the suction side. In the intermediate section, the pressure will gradually lower as the position moves from the delivery side to the suction side.

This phenomenon is shown in the drawing at right.

In addition, the gears in mesh will receive interacting forces.

These forces pushing the gears toward the suction side are received by the bearings. Since the gears are pressed toward the suction side by these forces, the radial clearance becomes smaller on the suction side in the case. In some pumps, the clearance may become zero, thus allowing the gear teeth and the case to come into light contact.

For this reason, an excessive increase in the delivery pressure must be avoided, since it will produce a large force which will act on the gears, placing an overload on the bearings, and resulting in a shortened service life of the bearing or interference of the gear with the case.

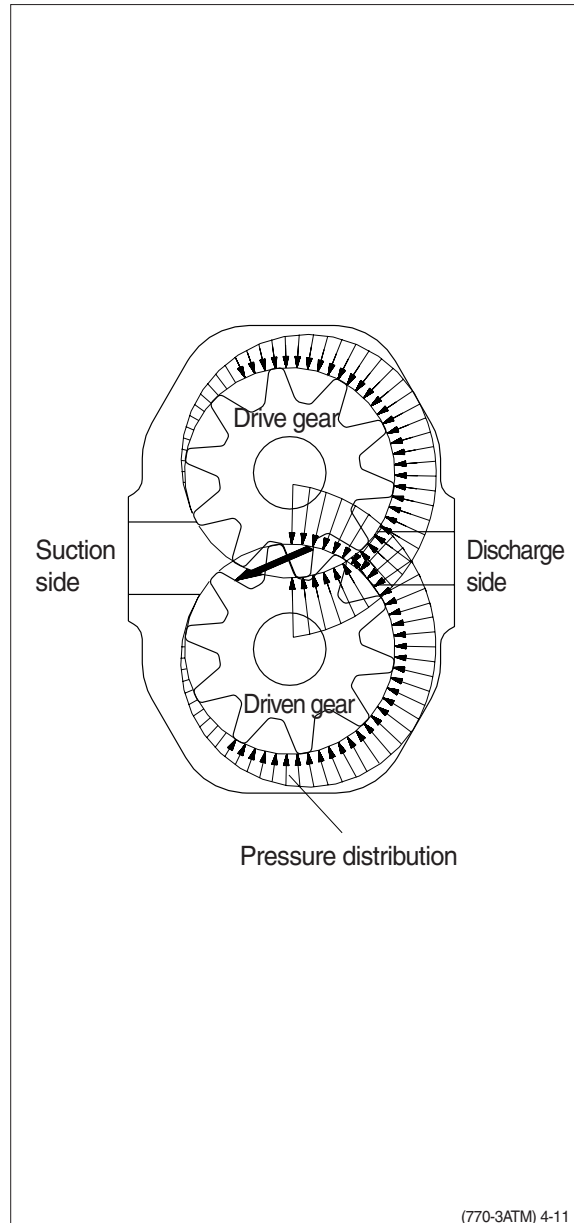

4. BRAKE VALVE

1) STRUCTURE

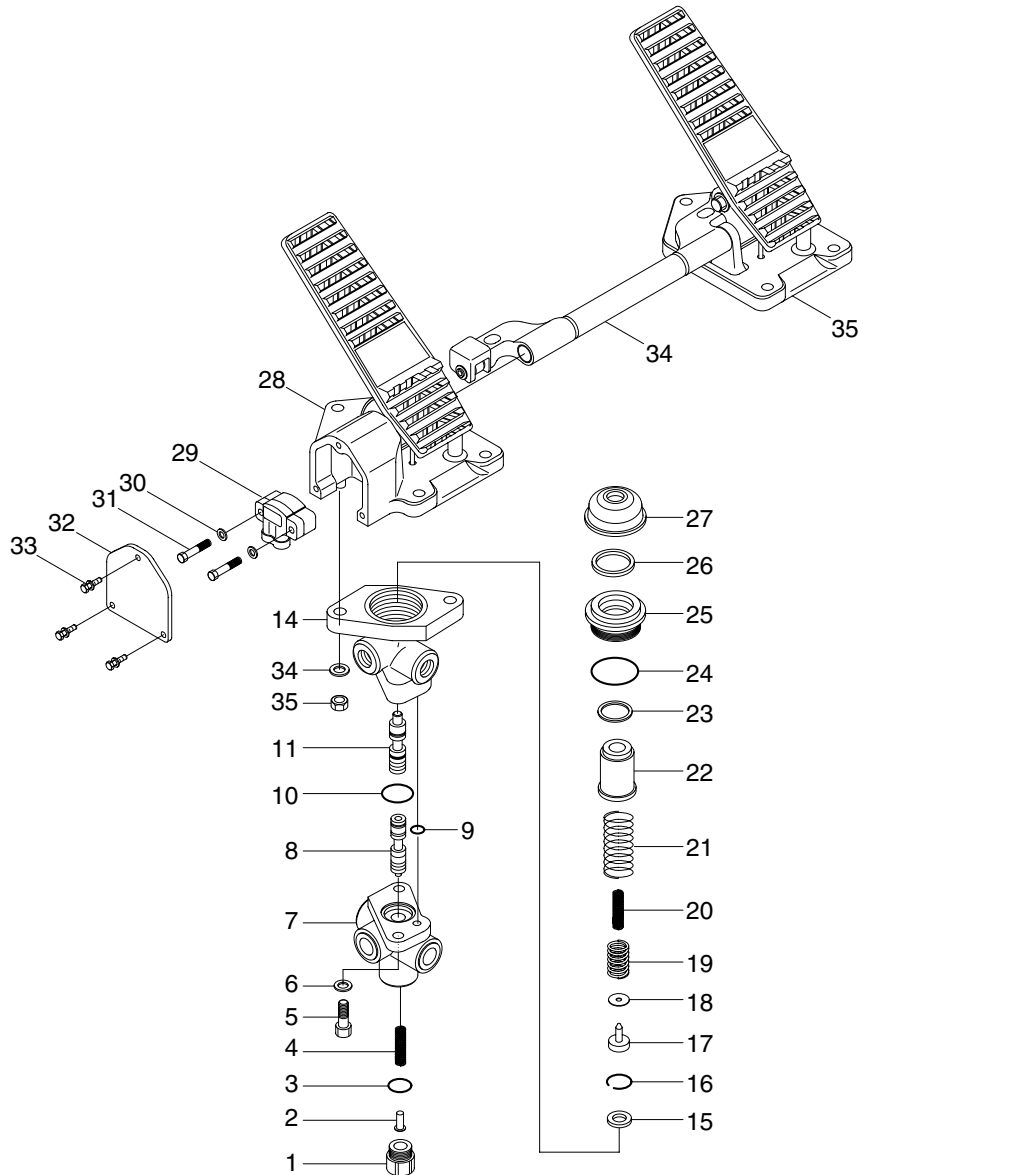

75794BS07

- | | | |
|----------------|-------------------|---------------------------------------|
| 1 Plug | 15 Spacer | 27 Boot |
| 2 Retainer | 16 Retaining ring | 28 Left pedal and base assy |
| 3 O-ring | 17 Retainer | 29 Sensor |
| 4 Spring | 18 Shim | 30 Washer |
| 5 Cap screw | 19 Spring | 31 Cap screw |
| 6 Washer | 20 Spring | 32 Cover |
| 7 Housing | 21 Spring | 33 Screw |
| 8 Lower spool | 22 Piston | 34 Lever assy (option) |
| 9 O-ring | 23 Quad ring | 35 Right pedal and base assy (option) |
| 10 O-ring | 24 O-ring | |
| 11 Upper spool | 25 Retainer | |
| 14 Housing | 26 Cup | |

2) OPERATION

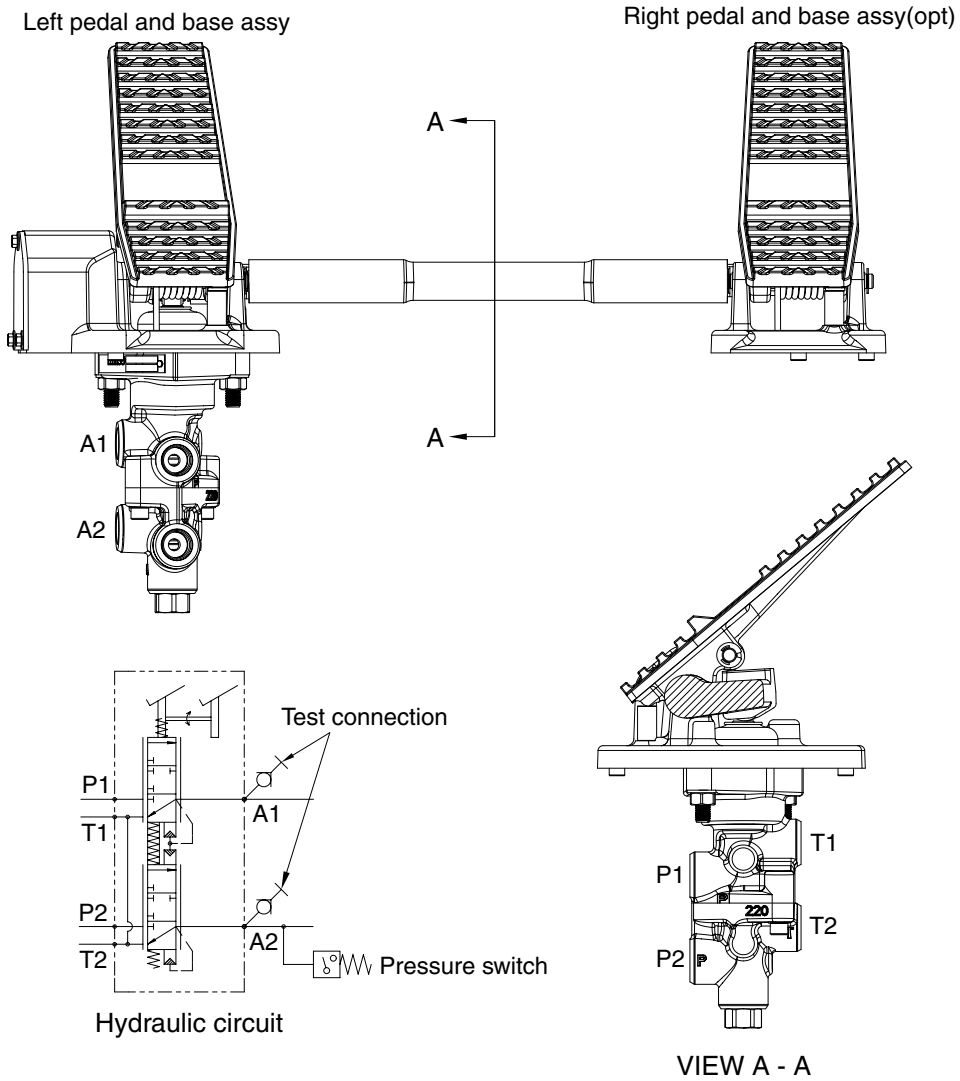

Port	Port name	Port size
P1, P2	Pressure port	3/4-16UNF
T1, T2	Return port	3/4-16UNF
A1, A2	Brake cylinder port	3/4-16UNF

· Brake pressure specification : 55 ± 5 bar (800 ± 70 psi)

75794BS08

(1) Purpose

The purpose of the brake valve is to sensitively increase and decrease the braking pressure when the brake pedal is actuated.

(2) Ready position

When the braking system is ready for operation, its accumulator pressure acts directly on ports (P1, P2) of the brake valve. A connection is established between ports (A1, A2) and ports (T1, T2) so that the wheel brake ports (A1, A2) are pressureless via the returns ports (T1, T2).

(3) Partial braking

When the brake valve is actuated, an amount of hydraulic pressure is output as a ratio of the foot force applied.

The spring assembly (21) beneath base (28) is designed in such a way that the braking pressure changes depending on the angle. In the lower braking pressure range, the machine can be slowed sensitively.

When the braking process is commenced, the upper spool is mechanically actuated via spring assembly (21), and the lower spool is actuated hydraulically by spool. As spools (11, 8) move downward, they will first close returns (T1, T2) via the control edges, thus establishing a connection between accumulator ports (P1, P2) and ports (A1, A2) for the wheel brake cylinders. The foot force applied now determines the output braking pressure. The control spools(11, 8) are held in the control position by the force applied (Spring assembly above the spools and the hydraulic pressure below the spool (Balance of forces).

After output of the braking pressure, spools (11, 8) are in a partial braking position, causing ports (P1, P2) and ports (T1, T2) to close and holding the pressure in ports (A1, A2).

(4) Full braking position

When pedal is fully actuated, end position of the brakes is reached and a connection established between accumulator ports (P1, P2) and brake cylinder ports (A1, A2). Returns (T1, T2) are closed at this point.

When the braking process is ended, a connection is once again established between brake cylinder ports (A1, A2) and return ports (T1, T2), closing accumulator ports (P1, P2).

The arrangement of spools in the valve ensures that even if one braking circuit fails the other remains fully operational. This is achieved by means of the mechanical actuation of both spools and requires slightly more pedal travel.

(5) Failure of a circuit

In the event of the lower circuit failing, the upper circuit will remain operational. Spring assembly (21) will mechanically actuate spool. In the event of the upper circuit failing, the lower circuit will remain operational since the lower spool (8) is mechanically actuated by spring assembly (21) and spool (11).

(6) Installation requirements

Return lines (T1, T2) must be connected directly to the tank.

The connecting lines must be installed in such a way as to permit proper bleeding.

(7) Maintenance of the brake valve

No special maintenance beyond the legal requirements is necessary.

When using high-pressure cleaners on the machine, please make sure that the water jet is not aimed directly at the brake valve (to prevent damaging the bellows).

△ **For safety reasons the whole of the brake valve must be replaced if parts other than those listed above are damaged.**

(8) Repair work

△ When working on the braking system, always make sure that there is absolutely no pressure in the system. Even when the engine is switched off there will be some residual pressure in the system.

※ When doing repair work, make sure your environment is very clean.
Immediately close all open ports on the components and on pipes using plugs.

(9) Replacing the complete actuating mechanism

Carefully clamp the unit vertically in a fixture. The actuating mechanism can be removed by taking out the three bolts. Make sure that spring assembly (21) does not fall out. When installing the new actuating mechanism, make sure that spring assembly (21) is fitted in the right order. Tighten the three bolts (5).

5. CUT-OFF VALVE

1) STRUCTURE

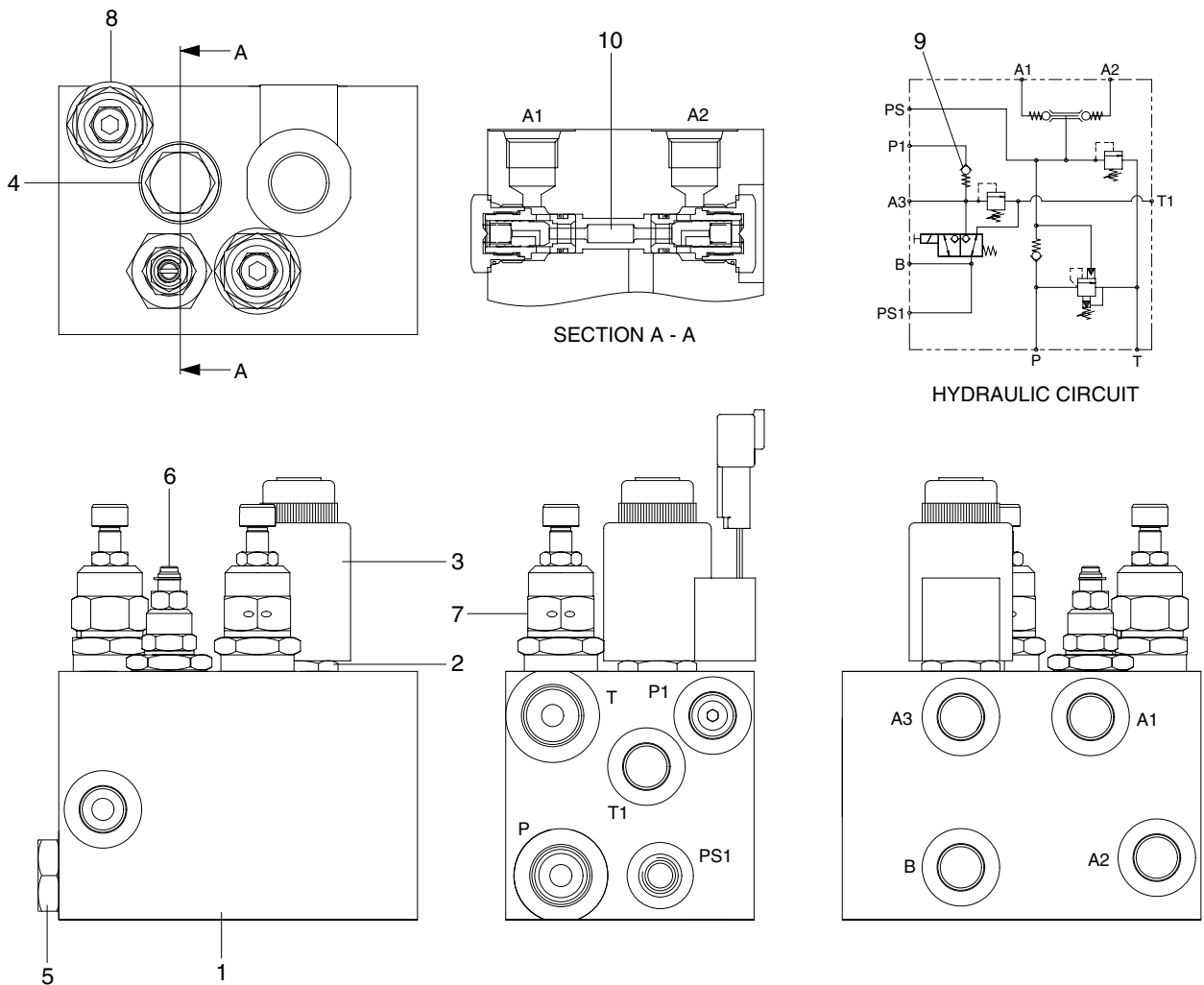

74094BS21

- | | | | |
|---|----------------|----|---------------|
| 1 | Manifold | 6 | Cut-off valve |
| 2 | Solenoid valve | 7 | Relief valve |
| 3 | Coil | 8 | Relief valve |
| 4 | Check valve | 9 | Check valve |
| 5 | Check valve | 10 | Spool bar |

Port name	Port size
P, T	PF 1/2
A1, A2, A3, B, T1, PS, P1	PF 3/8
PS1	PF 1/4

2) OPERATION

When the pump works, the oil under the pressure flows into P port.

The oil in P port is stored in the accumulator on A3 port.

As the pressure on P line rises to 150bar, the cut off valve (6) starts cut-offting and the oil in the P port is unloaded. The pressure on P line goes down 120 bar by the minute leakage from valve and other factors.

At this pressure, the cut-off valve starts cut-ining.

This process is repeated in the regular period of 30~40 seconds.

6. BRAKE ACCUMULATOR

1) STRUCTURE

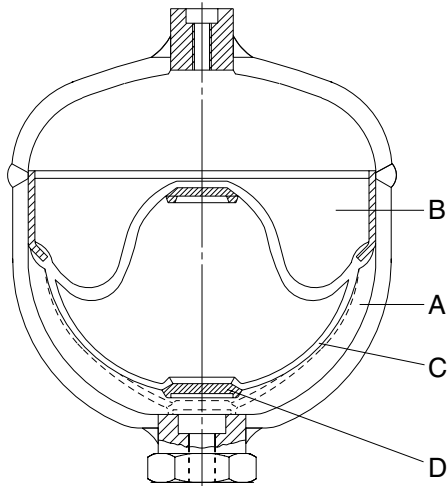

Item	81L1-0004 (item13)	31EC-02190 (item12)
Diameter	121 mm	136 mm
Mounting height	146 mm	160 mm
Norminal volume	0.75 ℓ	1.0 ℓ
Priming pressure	50 kgf/cm ²	50 kgf/cm ²
Operating medium	Oil	Oil
Operating pressure	Max 210 kgf/cm ²	Max 200 kgf/cm ²
Thread	M18 × 1.5	M18 × 1.5
Priming gas	Nitrogen	Nitrogen

A Fluid portion C Diaphragm
 B Gas portion D Valve disk

75794BS09

2) OPERATION

(1) Purpose

Fluids are practically incompressible and are thus incapable of accumulating pressure energy. In hydropneumatic accumulators, the compressibility of a gas is utilized to accumulate fluid. The compressible medium used in the accumulators is nitrogen.

In braking systems, the purpose of the accumulators is to store the energy supplied by the hydraulic pump. They are also used as an energy reserve when the pump is not working, as a compensator for any losses through leakage, and as oscillation dampers.

(2) Operation

The accumulator consists of a fluid portion (A) and a gas portion (B) with a diaphragm (C) as a gas-tight dividing element. The fluid portion (A) is connected to the hydraulic circuit, causing the diaphragm accumulator to be filled and the gas volume to be compressed as the pressure rises.

When the pressure falls, the compressed gas volume will expand, thus displacing the accumulated pressure fluid into the circuit.

The diaphragm bottom contains a valve disk (D) which, if the diaphragm accumulator is completely empty, closes the hydraulic outlet, thus preventing damage to the diaphragm.

(3) Installation requirements

The accumulators can be fitted in the hydraulic circuit, directly on a component or in blocks on suitable consoles.

They should be fitted in as cool a location as possible.

Installation can be in any position.

(4) Maintenance of the accumulator

No special maintenance beyond the legal requirements is necessary.

The accumulator should be checked annually. It should be replaced if the initial gas pressure has fallen by more than 30% (please refer to Performance testing and checking of the accumulator).

(5) Disposal of the accumulator

Before the accumulator is scrapped, its gas filling pressure must be reduced. For this purpose, drill a hole through gas chamber (B) using a drill approx. 3mm in diameter. The gas chamber is located on the side opposite the threaded port above the welding seam around the center of the accumulator.

※ Wear safety goggles when doing this job.

(6) Performance testing and checking of the accumulator

The accumulator is gradually pressurized via the test pump; until the initial gas pressure is reached, the hydraulic pressure in the accumulator will rise abruptly. This is apparent from gauge **M**. If the initial gas pressure is more than 30% below the prescribed value, the accumulator needs to be replaced. If the measuring process needs to be repeated, wait for intervals of 3 minutes between the individual tests. Any accumulator whose initial gas pressure is insufficient must be scrapped following the instructions under **Disposal of the accumulator**.

The amount of initial gas pressure can also be checked from the vehicle. Start the vehicle's engine. The pump will now supply oil to the accumulators. Until the initial gas pressure is reached, the hydraulic pressure in the accumulator will rise abruptly. This is apparent from the gauge in the cab. If the initial gas pressure is more than 30% below the prescribed value, that initial pressure lies outside the permissible range for **at least one** of the accumulators fitted in the vehicle. This accumulator can be traced only by using the method described above, i.e. all accumulators have to be individually tested. The accumulator whose initial gas pressure is insufficient must be replaced and scrapped following the instruction under **Disposal of the accumulator**.

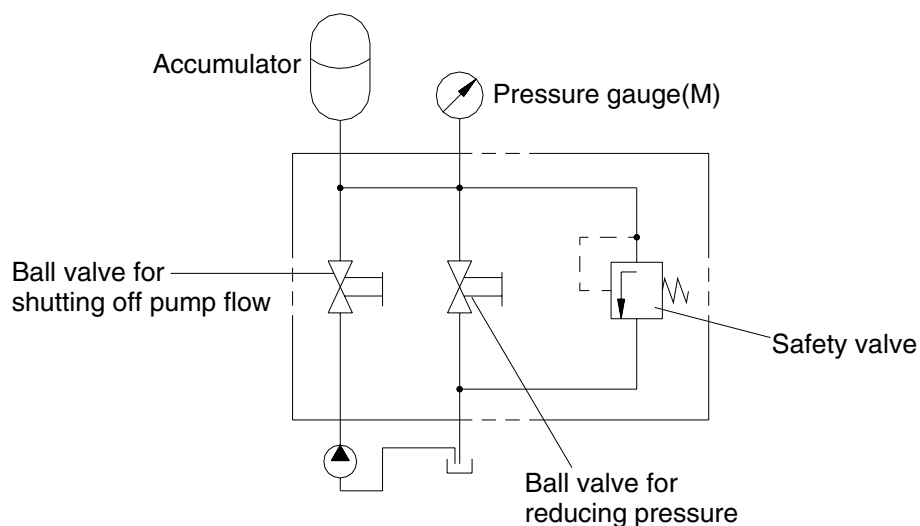

75794BS10

(7) Repair work

△ When working on the braking system, always make sure that there is absolutely no pressure in the system. Even when the engine is switched off there will be some residual pressure in the system.

※ When doing repair work, make sure your environment is very clean.

Immediately close all open ports on the components and on pipes using plugs.

△ For safety reasons the accumulators need to be replaced as a whole if damaged.

7. PRESSURE SENSOR AND SWITCH

1) STRUCTURE

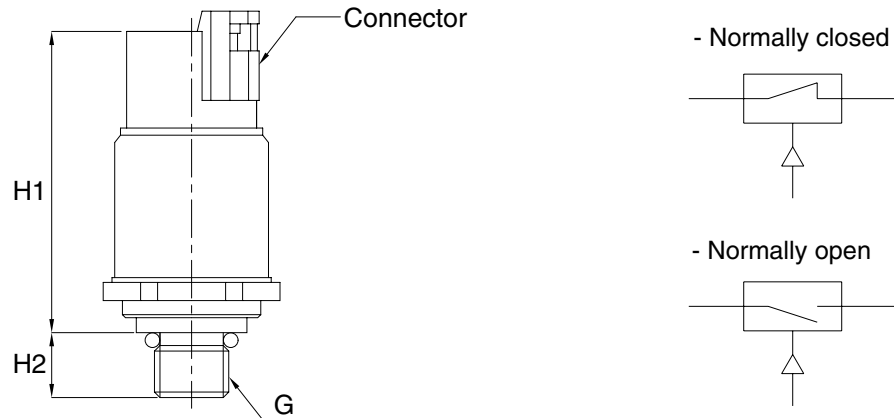

75794BS11

2) Technical data

Item	Type	Medium	G	H1 mm	H2 mm	Adjusting range kgf/cm ²	Actuating pressure kgf/cm ²	Voltage V
Parking pressure sensor	NC	Oil	PF 1/4"	49.6	11	0 ~ 200	17 ± 2	Max 30
Charging pressure sensor	NC	Oil	PF 1/4"	49.6	11	0 ~ 200	100 ± 5	Max 30
Brake stop pressure switch	NO	Oil	PF 1/4"	49.6	11	-	5 ± 1	Max 32

NC : Normally closed NO : Normally open

2) OPERATION

(1) Purpose

The pressure switches are used to visually or audibly warn the driver of the pressure within the system.

(2) Make contact / circuit closer

The pressure switch can be fitted in the braking system or directly on one of its components.

The system pressure acts on an absorption area within the switch, making an electrical contact as the pressure on that area is increased. The resulting current is used to activate a warning facility, for instance.

(3) Break contact / circuit breaker

The pressure switch can be fitted in the braking system or directly on one of its components.

The system pressure acts on a absorption area within the switch, breaking an electrical contact as the pressure on that area is increased. The current is now broken, e.g. to deactivate a warning facility.

(4) Installation requirements

No special measures need to be taken.

(5) Maintenance of the pressure switch

No special maintenance beyond the legal requirements is necessary.

When using high-pressure cleaners on the vehicle, please make sure that the water jet is not directed at the pressure switch (corrosion of contacts).

(6) Repair work

△ When working on the braking system, always make sure that there is absolutely no pressure in the system. Even when the engine is switched off there will be some residual pressure in the system.

※ When doing repair work, make sure your environment is very clean.

Immediately close all open ports on the components and on pipes using plugs.

※ For safety reasons the pressure switch needs to be replaced as a whole if damaged.