

GROUP 4 DISASSEMBLY AND ASSEMBLY

1. CONTROL VALVE

1) DISASSEMBLY

- (1) Illustration on the right shows the complete control unit.

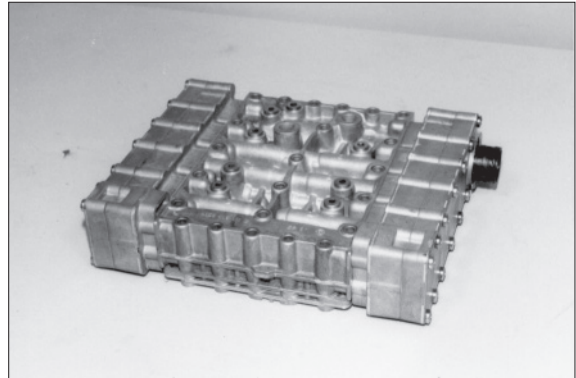

73073CV001

- (2) Mark the installation position of the different covers, the housing and cable harness with the valve housing.

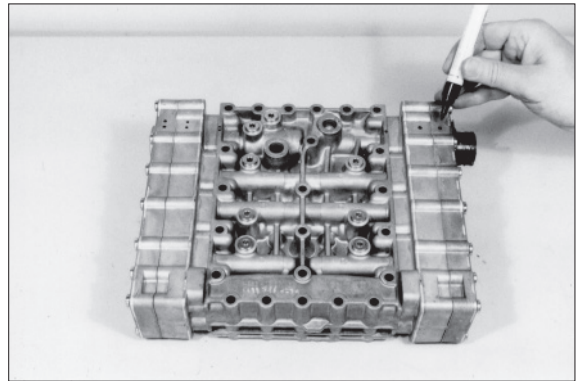

73073CV002

- (3) Loosen socket head screws.
Separate duct plate, 1st gasket, intermediate plate and 2nd gasket from the valve housing.
Box spanner 5873 042 002

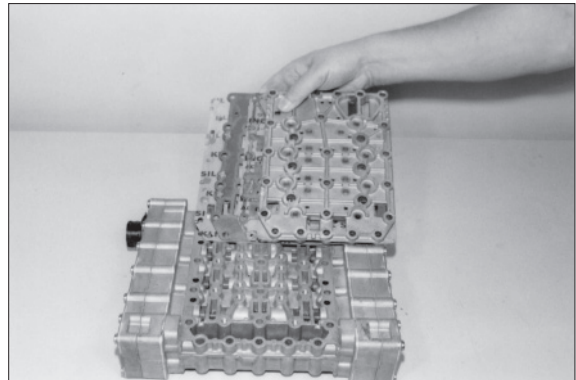

73073CV003

- (4) Remove retaining clip.

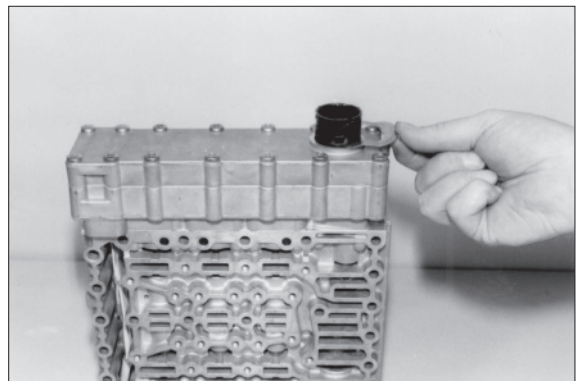

73073CV004

- (5) Loosen socket head screws.
Separate cover from housing and cable harness.
Box spanner 5873 042 002

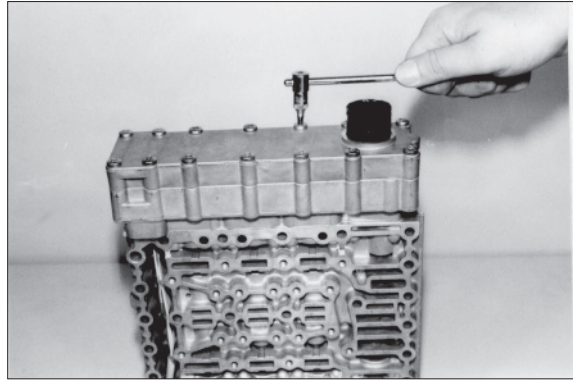

73073CV005

- (6) Disassemble opposite cover.
Disconnect pressure regulator and remove cable harness.

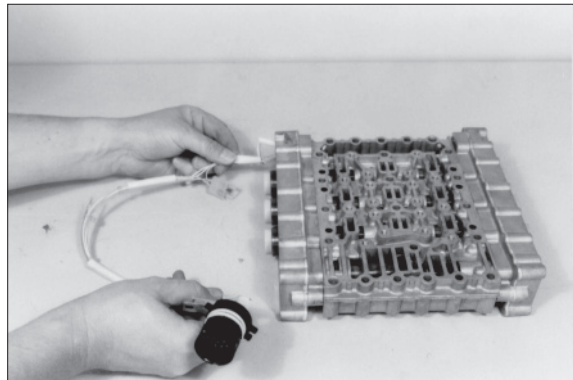

73073CV006

- (7) Loosen socket head screws, remove fixing plate and pressure regulators (3EA).
Box spanner 5873 042 002

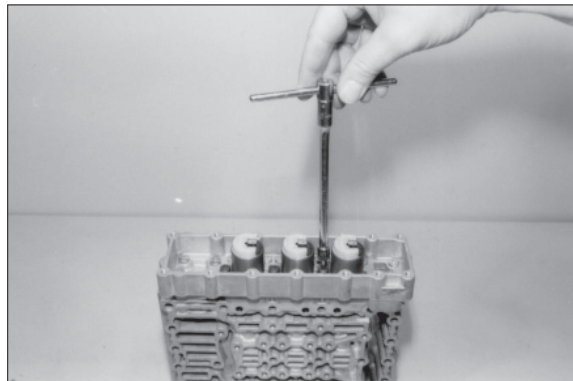

73073CV007

- (8) Loosen two socket head screws and locate housing provisionally, using adjusting screws (housing is under spring preload).
Now, loosen remaining socket head screws.
Box spanner 5873 042 002
Adjusting screws 5870 204 036

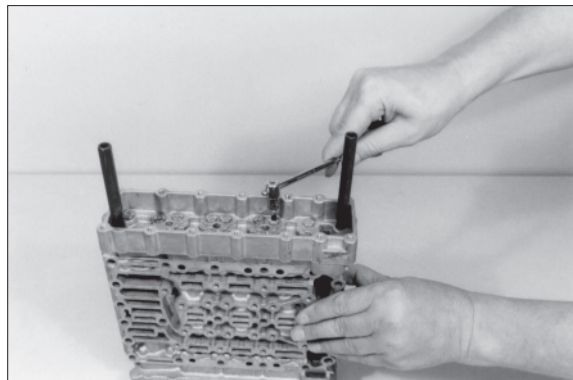

73073CV008

- (9) Separate housing from valve housing by loosening the adjusting screws uniformly.
Adjusting screws 5870 204 036

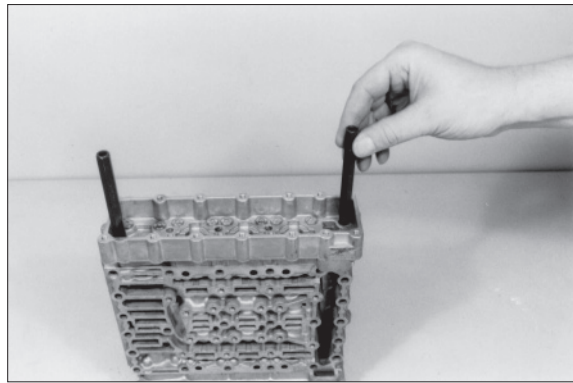

73073CV009

- (10) Remove components.

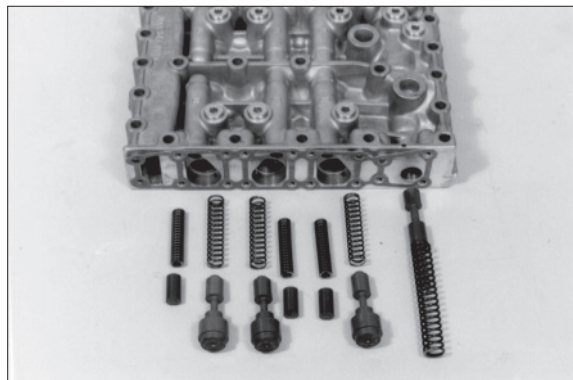

73073CV010

- (11) Remove opposite pressure regulators, housing as well as components accordingly.

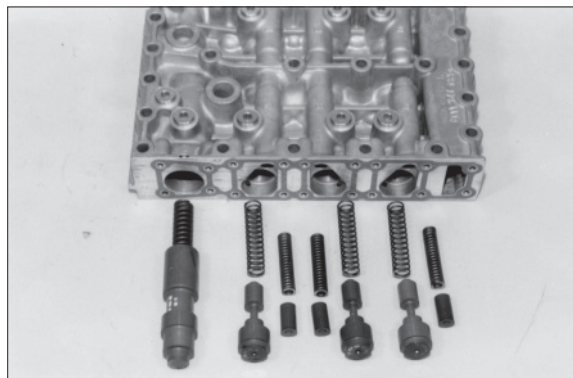

73073CV011

2) ASSEMBLY

- ※ Check all components for damage and renew if necessary.
Prior to the installation, check free travel of all moving parts in the housing.
Spools can be exchanged individually.
Oil the components prior to the assembly.
Insert diaphragms with the concave side showing upward until contact is obtained.
- ※ Installation position, see arrows.

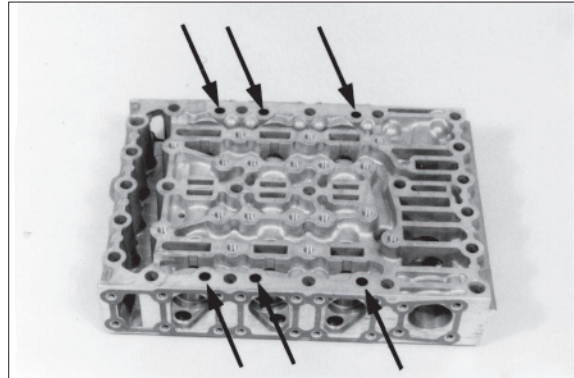

73073CV015

(1) Illustration on the right shows the following components.

- 1 Vibration damper
- 2 Follow-on slide
- 3 Pressure reducing valve

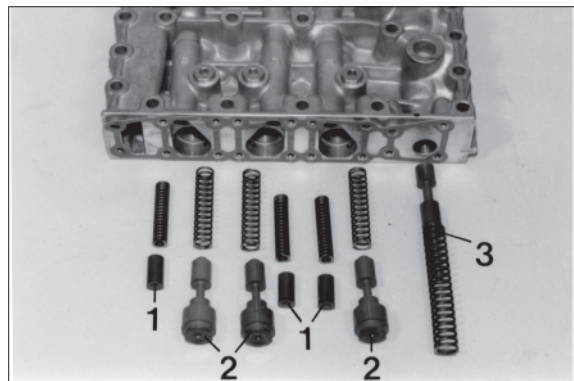

73073CV016

(2) Install components according to figure (1).

- ※ Preload compression spring of the follow-on slides and locate spool provisionally by means of cylindrical pins $\varnothing 5.0$ mm (assembly aid), see arrows.

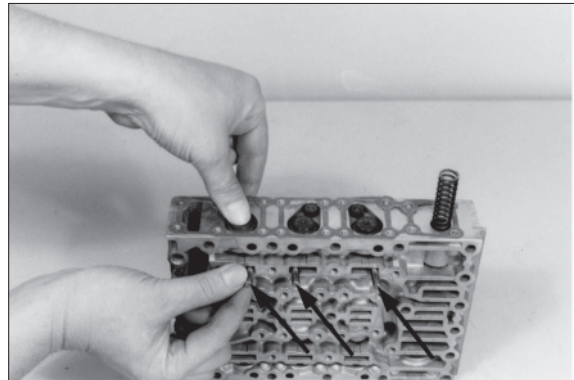

73073CV017

(3) Install two adjusting screws.

Assemble gasket (arrow 1) and housing cover. Now, position the housing cover uniformly, using adjusting screws, until contact is obtained and remove cylindrical pins (assembly aid) again (see the next figure).

- ※ Pay attention to the different housing covers.
Install recess $\varnothing 15$ mm (arrow 2), facing the spring of the pressure reducing valve.
Adjusting screws 5870 204 036

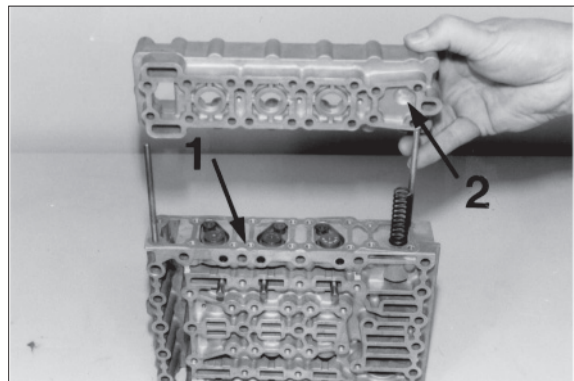

73073CV018

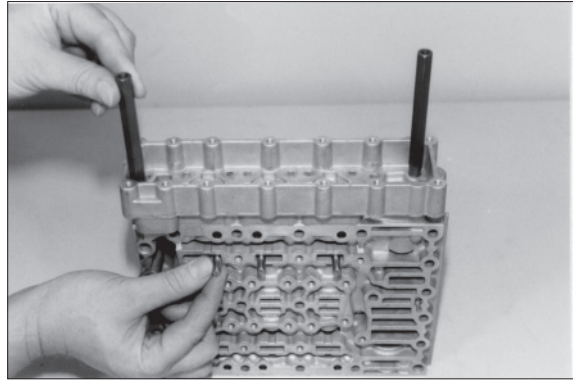

73073CV019

- (4) Fasten housing cover by means of socket head screws.
 · Torque limit : 0.56 kgf · m (4.06 lbf · ft)
 Box spanner 5873 042 002

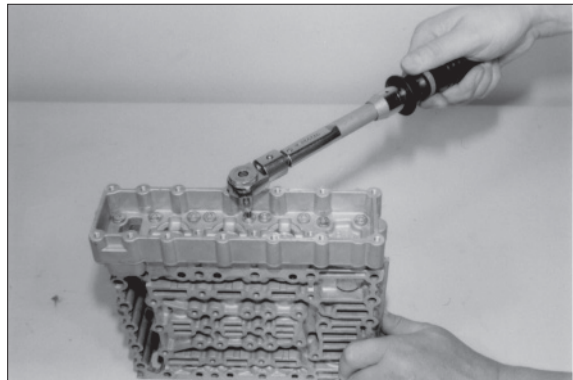

73073CV020

- (5) Introduce pressure regulators and fix by means of fixing plates and socket head screws.
 ※ Install fixing plate, with the claw showing downward.
 Pay attention to the radial installation position of the pressure regulators, see figure.
 · Torque limit : 0.56 kgf · m (4.06 lbf · ft)
 Box spanner 5873 042 002

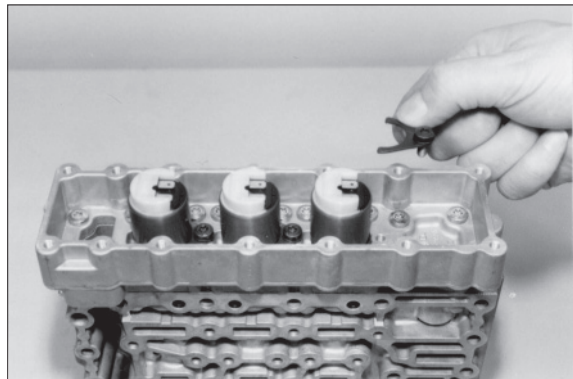

73073CV021

Pre assemble opposite side

- (6) Illustration on the right shows the following components.
 1 Main pressure valve
 2 Follow on slide
 3 Vibration damper

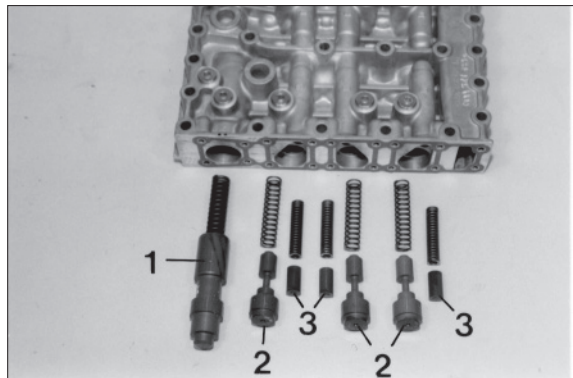

73073CV022

- (7) Install components according to figure (6).
Preload compression springs of the follow-on slides and locate spool provisionally by means of cylindrical pins $\varnothing 5.0$ mm (assembly aid), see arrows.
Install two adjusting screws.

Assemble gasket (arrow 1) and housing cover, and position them uniformly against shoulder, using adjusting screws.

- ※ Pay attention to the different housing covers-install the recess $\varnothing 19$ mm (arrow 2), facing the main pressure valve.
Now, fasten housing cover by means of socket head screws.

· Torque limit : 0.56 kgf · m (4.06 lbf · ft)

Remove cylindrical pins (assembly aid) again.

Adjusting screws 5870 204 036

Box spanner 5873 042 002

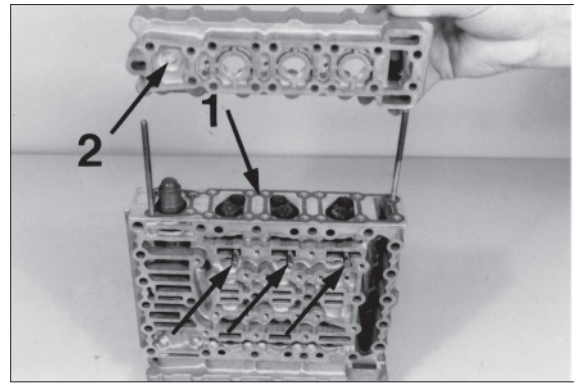

73073CV023

- (8) Introduce pressure regulators and fix by means of fixing plates and socket head screws.

- ※ Install fixing plates, with the claw showing downward.

Pay attention to the radial installation position of the pressure regulators, see figure.

· Torque limit : 0.56 kgf · m (4.06 lbf · ft)

Box spanner 5873 042 002



73073CV024

- (9) Introduce cable harness and connect pressure regulators (6EA).

- ※ Pay attention to the installation position of the cable harness, ass also markings (See figure (2), page 3-74).

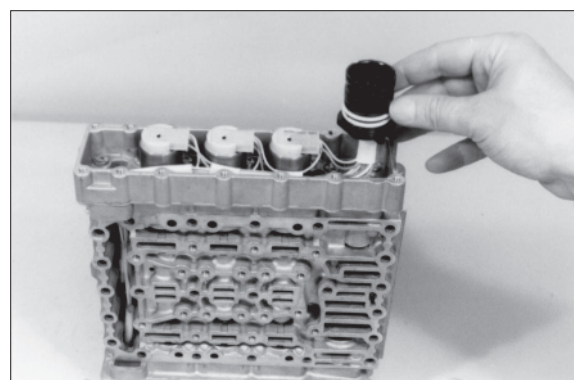

73073CV025

(10) Introduce female connector against shoulder, with the groove facing the guide nose of the cover.

Install gasket (arrow) and fasten cover by means of socket head screws.

· Torque limit : 0.56 kgf · m (4.06 lbf · ft)

Box spanner 5873 042 002

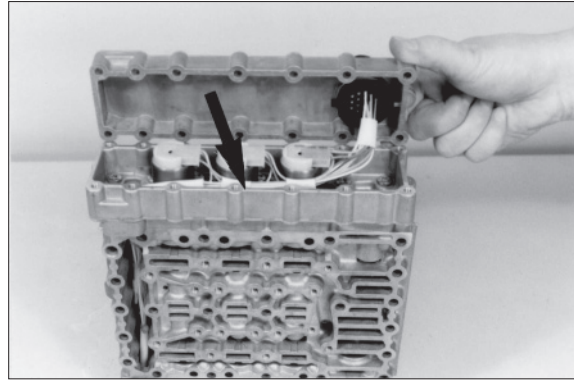

73073CV026

(11) Fix female connector by means of retaining clamp, see figure.

Install opposite cover.

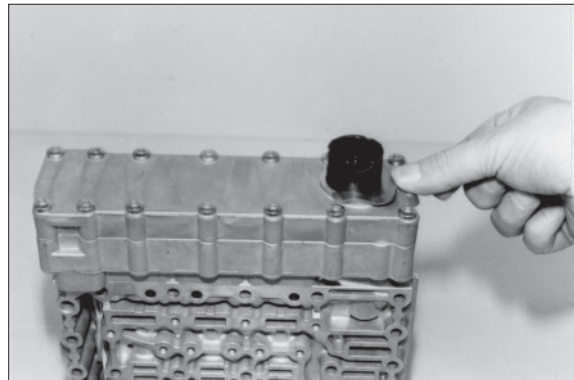

73073CV027

(12) Install two adjusting screws and mount gasket I.

※ Pay attention to the different gaskets, see on the right figure and (15).

Adjusting screws 5870 204 063

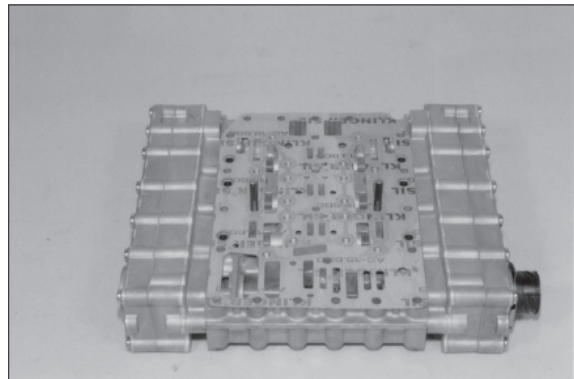

73073CV028

Intermediate plate-Version with screens

(13) Insert screws (6EA) flush mounted into the bore of the intermediate plate, see arrow.

※ Pay attention to the installation position-screws are showing upward (facing the duct plate).

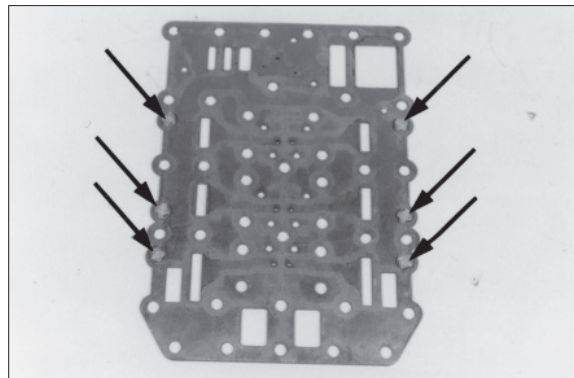

73073CV029

(14) Mount intermediate plate, with the screens showing upward.

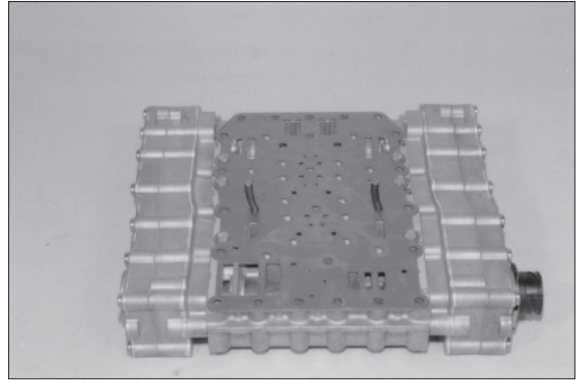

73073CV030

(15) Mount gasket II.

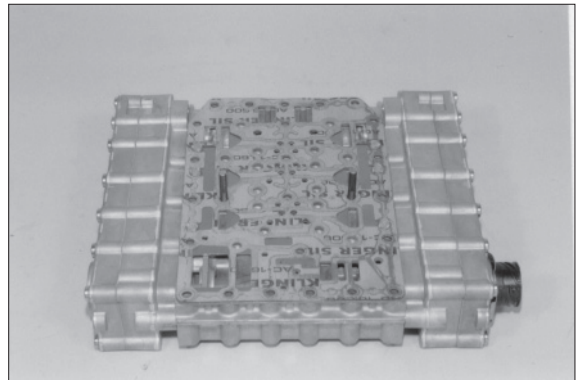

73073CV031

(16) Mount duct plate and fasten it uniformly by means of socket head screws.

· Torque limit : 0.97 kgf · m (7.0 lbf · ft)

Box spanner 5873 042 002

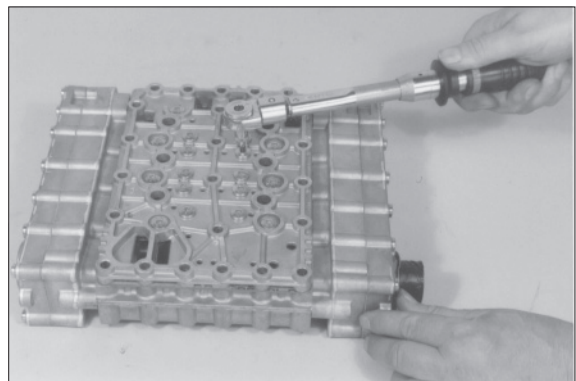

73073CV032

(17) Equip screw plug (8EA) with new O-rings and install them.

· Torque limit : 0.56 kgf · m (4.06 lbf · ft)

※ The installation of the hydraulic control unit is described, starting from page 3-135.

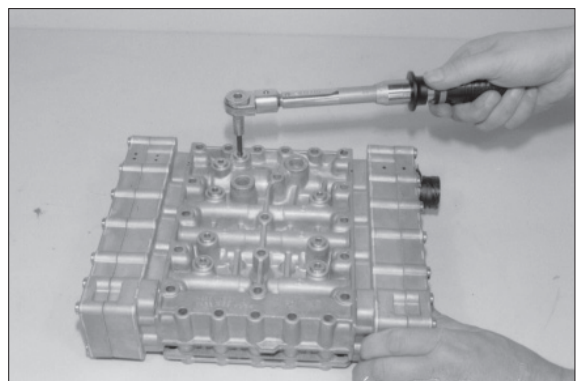

73073CV033

2. TRANSMISSION

1) DISASSEMBLY

(1) Remove filter unit

- ① Demount warning switch (arrow) from filter head.

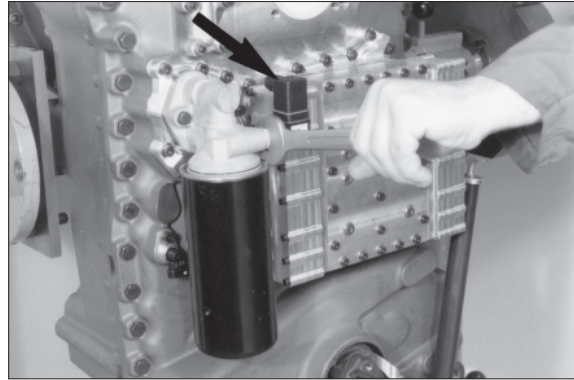

73073TM002

- ② Separate oil filter from filter head.

※ Special tool

Belt spanner 5870 105 005

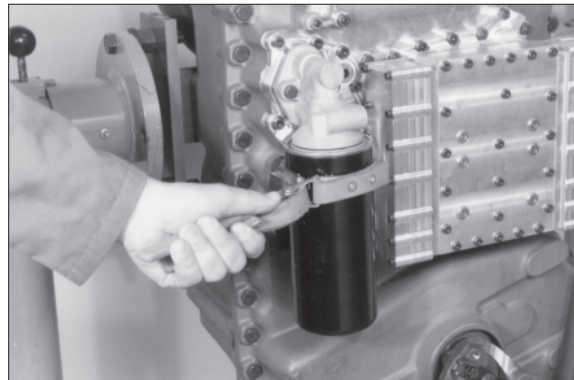

73073TM003

- ③ Loosen hexagon head screws and separate filter head from duct plate.

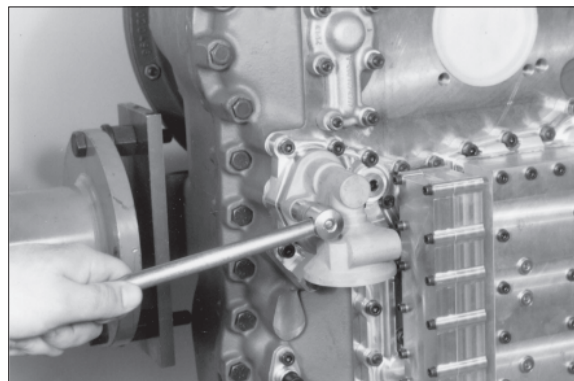

73073TM004

(2) Separate hydraulic control unit and duct plate from gearbox housing

- ① Loosen socket head screws, install two adjusting screws and separate control unit from duct plate.

※ Special tool

Adjusting screw 5870 204 031

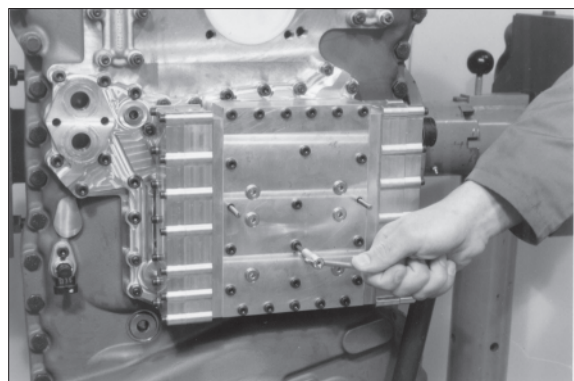

73073TM004

② Remove both gaskets as well as intermediate plate.

※ Special tool

Adjusting screws 5870 204 031

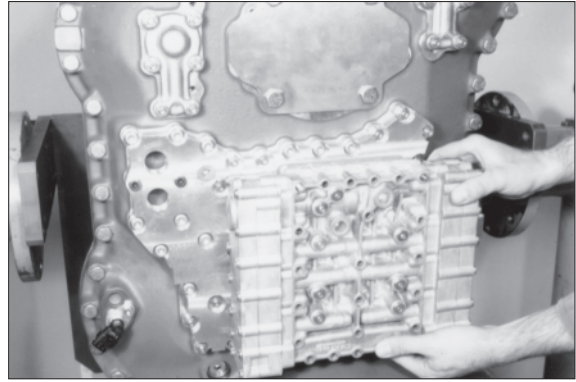

75773TM051

③ Loosen socket head screws and hexagon nuts and separate duct plate from gearbox housing.
Now, remove flat gasket.

※ Special tool

Adjusting screws 5870 204 031

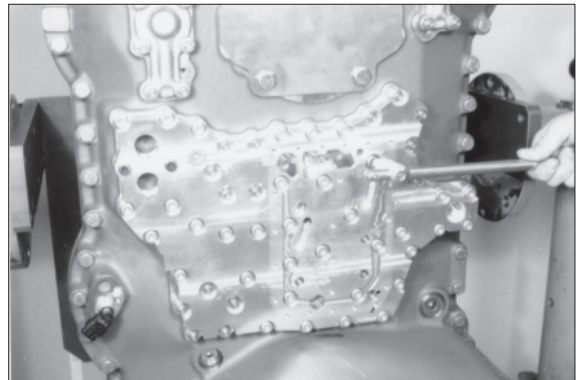

75773TM052

(3) Remove and disassemble converter safety valve

① Pull converter safety valve out of the housing bore.

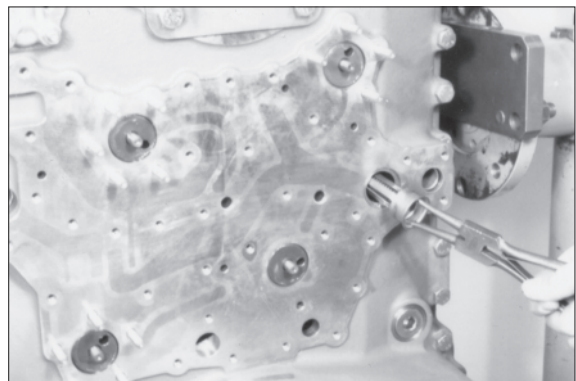

75773TM053

② Illustration on the right shows the required special tool for the disassembling of the converter safety valve.

1 Converter safety valve

※ Special tool

Assembly aid 5870 345 084

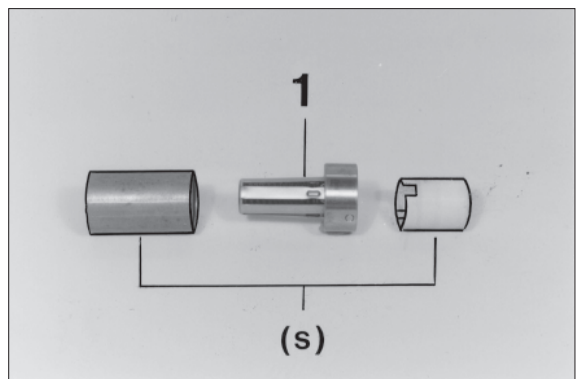

73073TM009

- ③ Preload compression spring carefully, remove cylindrical pin (see on the right figure) and demount components (see on the below figure).

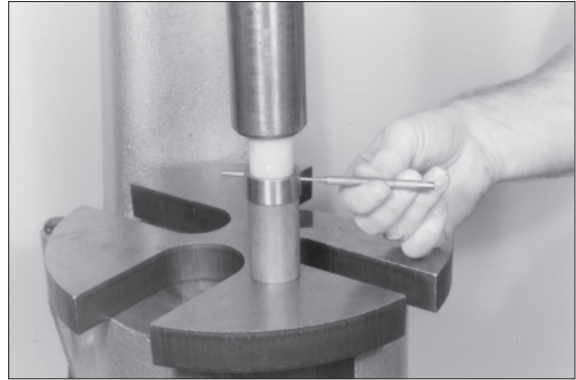

73073TM010

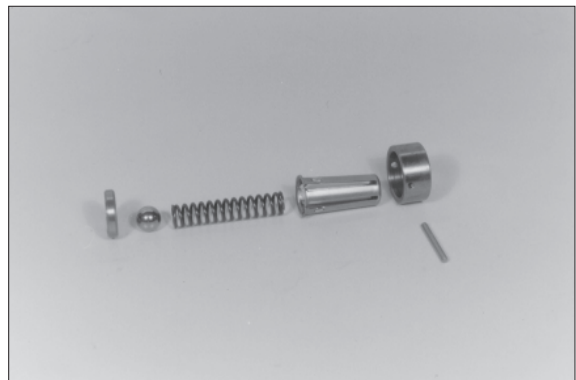

73073TM011

(4) Engine connection-Converter

- ① Remove lock plate and loosen hexagon head screws.
Remove disk and pry input flange from the shaft.

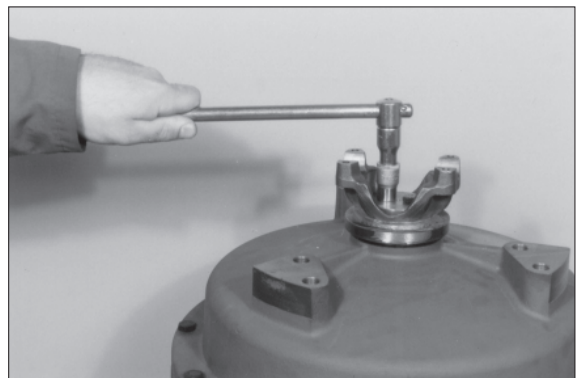

73073TM015

- ① Loosen screw connection.
※ Mark radial installation position of the housing cover.

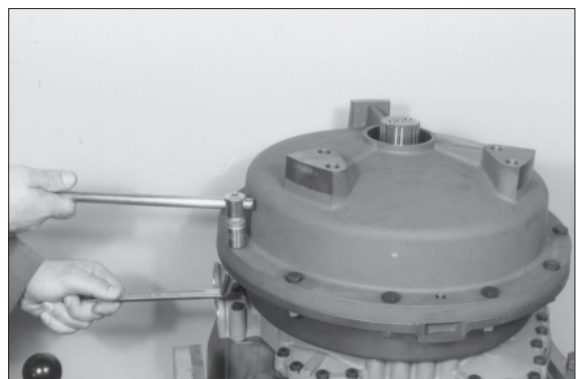

73073TM016

- ③ Separate cover along with converter from the transmission, using lifting device.

※ Special tool

Set of eye bolts 5870 204 002

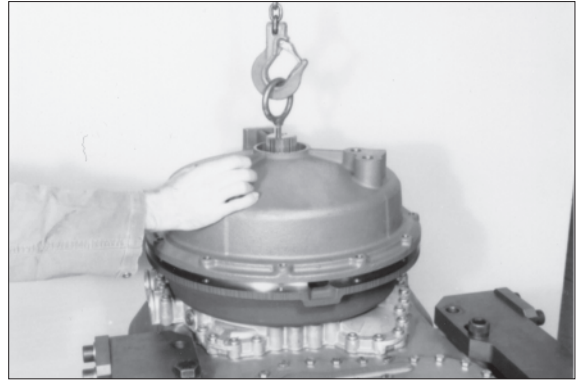

75773TM057

- ④ Press input shaft, respectively converter out of the cover (ball bearing).

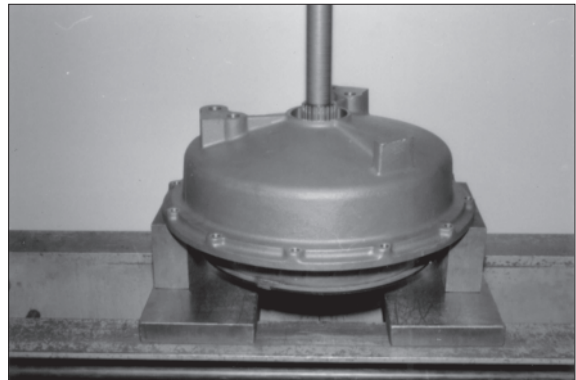

75773TM058

- ⑤ Squeeze circlip out and remove ball bearing.

※ Special tool

Set of internal pliers 5870 900 013



75773TM059

- ⑥ Loosen hexagon head screws and separate membrane from converter.

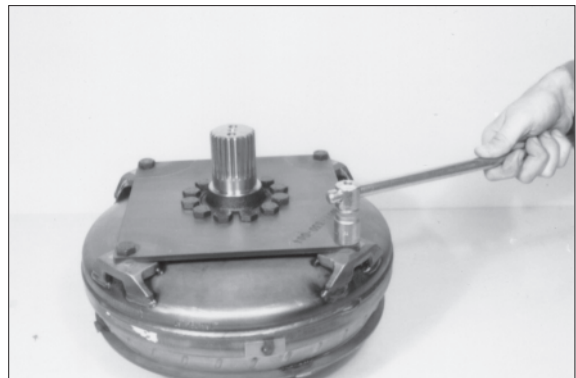

75773TM060

- ⑦ Loosen hexagon head screws and separate input shaft from the membrane.

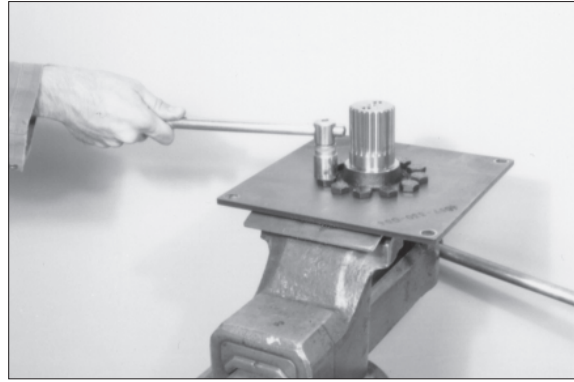

75773TM061

- ⑧ Remove inductive transmitter (n Enging).

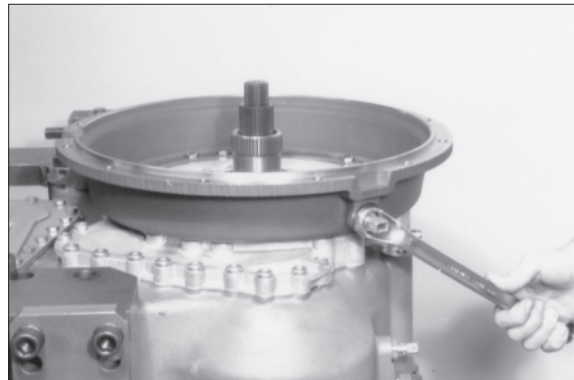

75773TM062

- ⑨ Loosen hexagon head screws and remove converter housing.



75773TM063

(5) Remove transmission pump

- ① Loosen socket head screws.

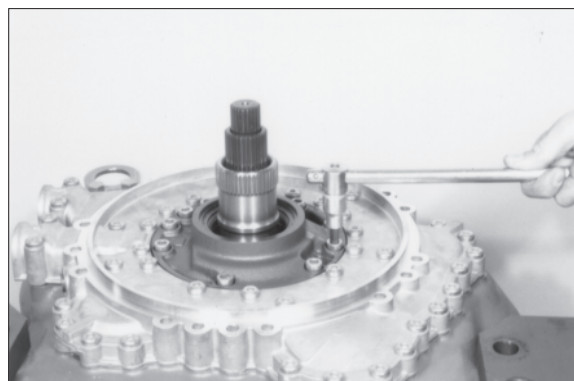

75773TM064

- ② Apply separating device on the splines runout of the stator shaft and pull pump out of the housing bores, using two-leg puller.

※ Special tool

Separating device 5870 300 024

Two-leg puller 5870 970 004

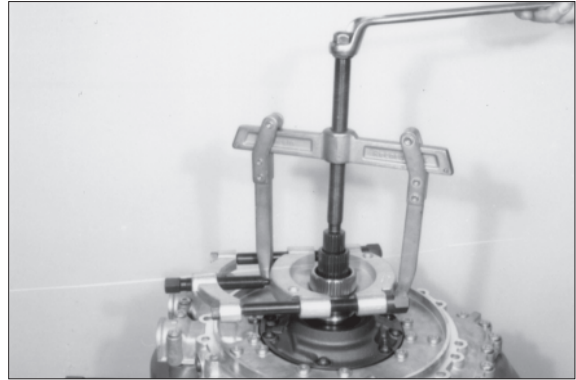

75773TM065

- ③ Separate transmission pump from stator.
Separate cam plate from pump.

※ If traces of wear should be encountered in the pump housing or the cam disk, the complete pump has to be renewed.

Now, fit cam disk again and fix it by means of grooved pins (2EA).



75773TM066

- ④ Loosen hexagon head screws and remove oil feed housing.
Now, remove flat gasket.

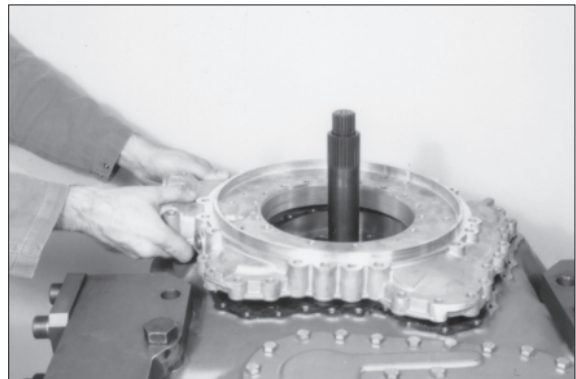

75773TM067

(6) Converter pressure valve

- ① Pull converter pressure valve out of the housing bore.

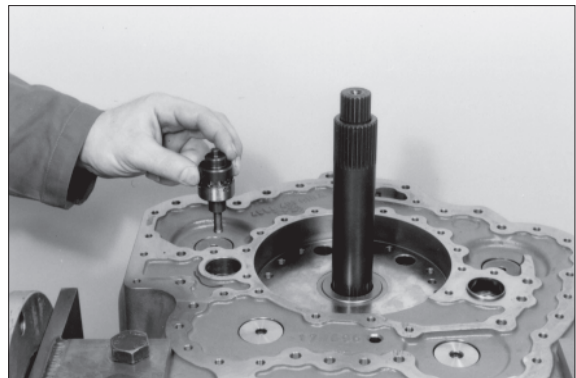

73073TM028

- ② Illustration on the right shows the special tool required for the disassembling of the converter pressure valve.

1 Converter pressure valve

- ※ Special tool

Assembly aid 5870 345 084

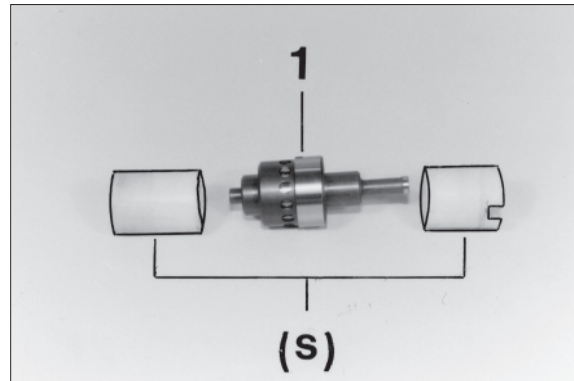

73073TM029

- ③ Preload compression spring carefully, drive roll pin out and remove components.

- ※ Special tool

Assembly aid 5870 345 084

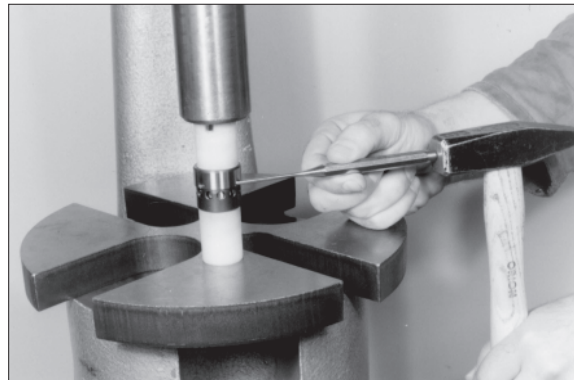

73073TM030

- ④ Loosen hexagon head screws, demount cover and remove flat gasket.

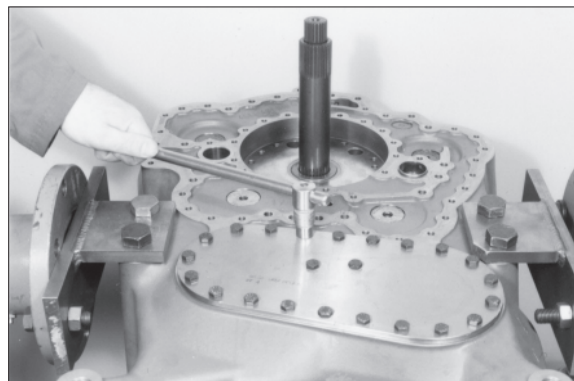

73073TM031

(7) Demount output, input and clutches

- ① Remove lock plate, loosen hexagon head screws, and pry the converter-side output flange from the shaft.

Now, pry shaft seal out of the housing bore.

Tilt gearbox 180° and remove rear output flange accordingly.

- ※ Special tool

Pry bar 5870 345 065

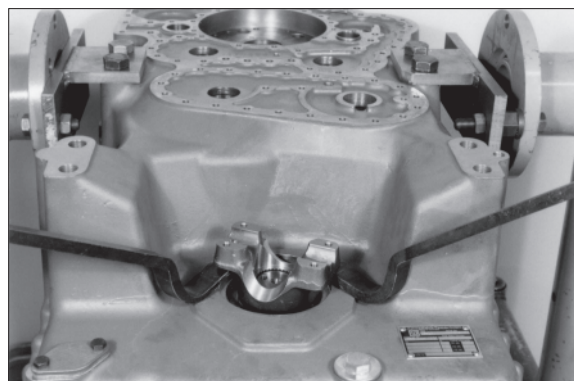

73073TM035

- ② Demount speed sensor as well as both inductive transmitters (Arrows).

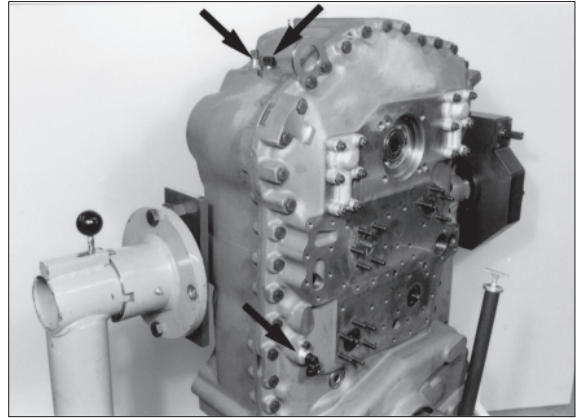

73073TM036

- ③ Loosen hexagon nuts and remove the two covers (Arrows).
Loosen screw connection.

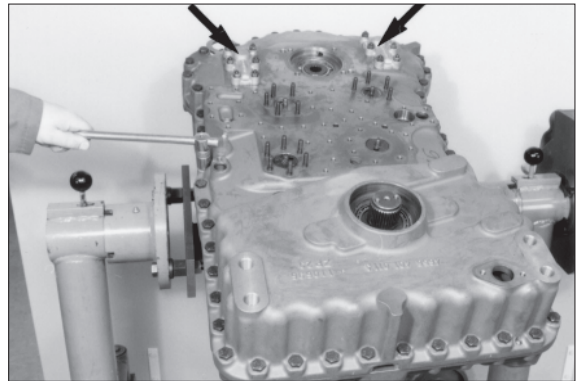

73073TM037

- ④ Drive both cylindrical pins (Arrows) out.

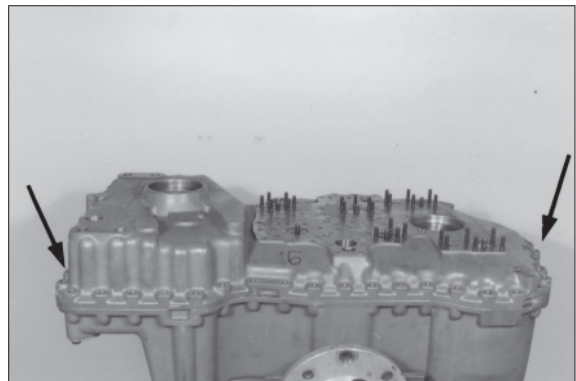

73073TM038

- ⑤ Separate housing cover carefully from gearbox housing, using lifting device.
※ Special tool
Lifting chain 5870 281 047

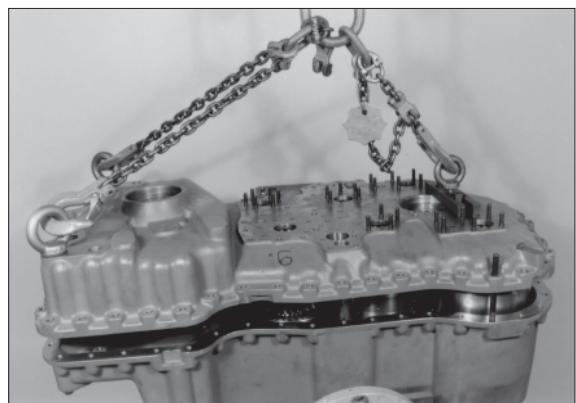

73073TM039

- ⑥ On the right figure shows the installation position of the single clutches as well as of the input and output.

KV Forward clutch

KR Reverse clutch

K1 1st speed clutch

K2 2nd speed clutch

K3 3rd speed clutch

K4 4th speed clutch

AN Input

AB Output

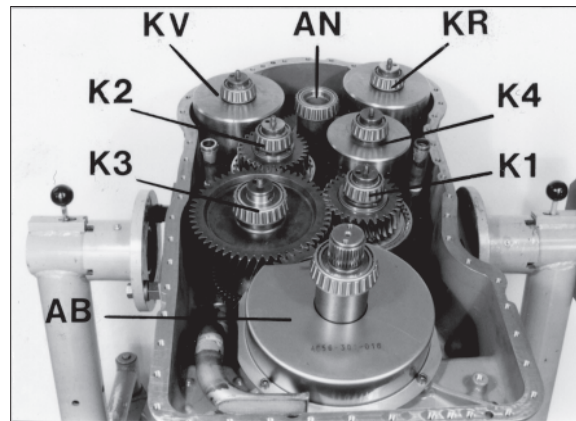

73073TM040

- ※ The following figures describe the common removal of all clutches.

For this purpose, the housing cover, combined with special tool is necessary.

The removal of single clutches without help of the housing cover and the handles is extremely difficult because of the installation condition.

Besides, there is the danger of injuries.

- ※ Prior to the common removal of the clutches, the output shaft must be removed, see the below figure.

- ⑦ Loosen socket head screws and remove output shaft as well as both oil baffle plates.

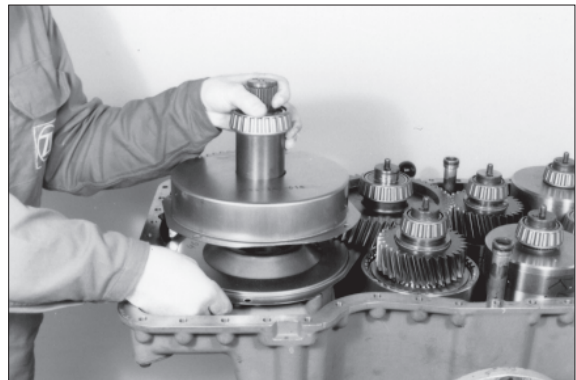

73073TM042

- ⑧ Assemble housing cover carefully until contact is obtained.
Fix all clutches in the housing cover, using handles.

※ Special tool
Handle(6EA needed) 5870 260 010

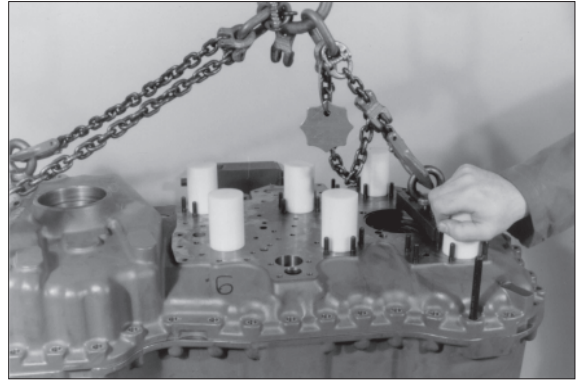

73073TM201

- ⑨ Separate housing cover along with clutches from gearbox housing, using lifting device.

※ Special tool
Handle(6EA needed) 5870 260 010

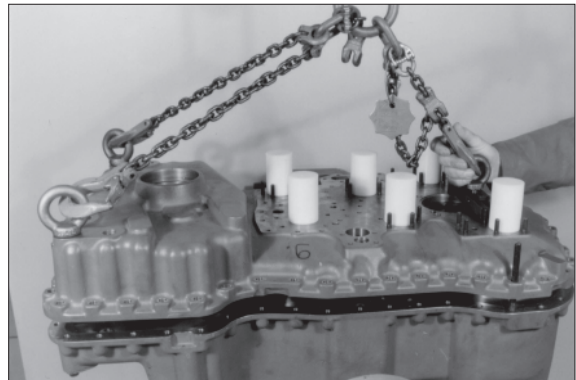

73073TM200

- ⑩ Fasten housing cover on assembly car.

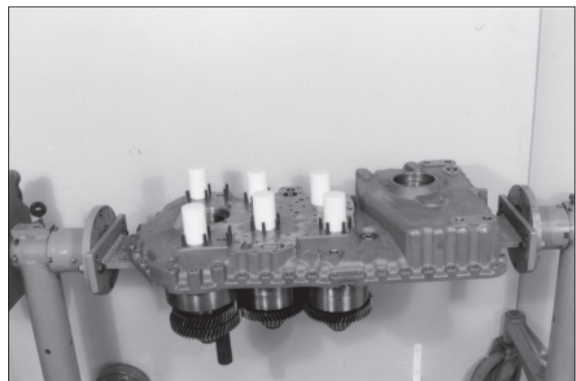

73073TM045

- ⑪ Tilt housing cover 180° .
Remove handles.

※ Special tool
Handle(6EA needed) 5870 260 010

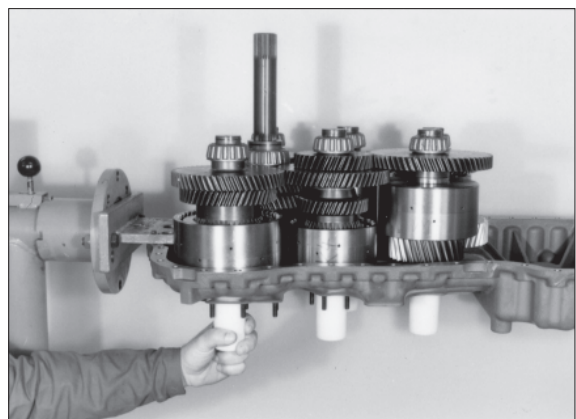

73073TM046

⑫ Remove K2 clutch.

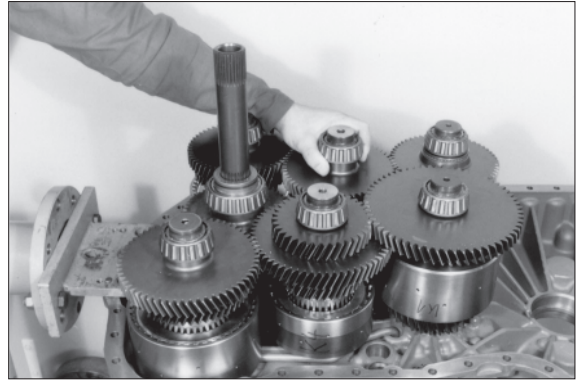

73073TM047

⑬ Remove K1 clutch, at the same time, lift K4 clutch.



73073TM048

⑭ Lift K3 clutch out of the housing cover.

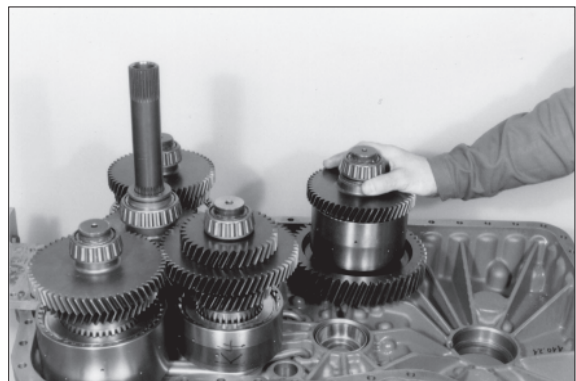

73073TM049

⑮ Remove K4 clutch, at the same time lift input slightly.

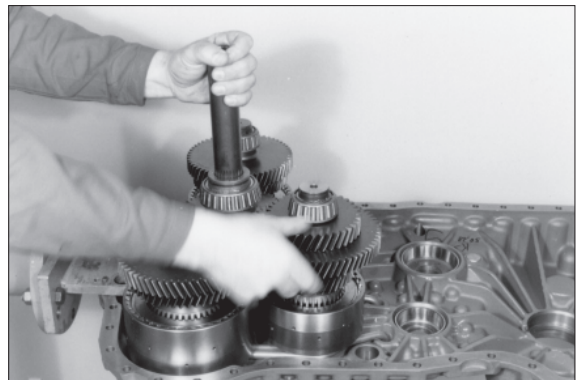

73073TM050

- ⑩ Separate KV and KR clutches together with input from the housing cover.

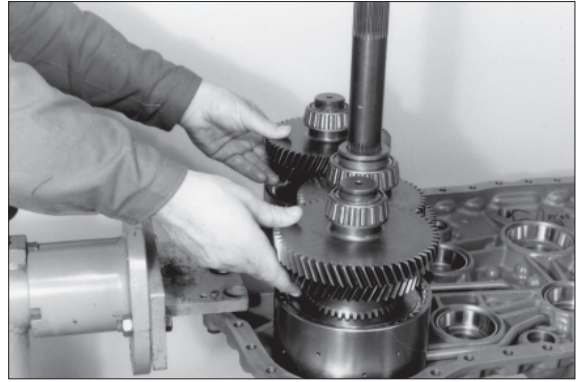

73073TM051

- ⑪ Remove bearing outer race and pull output shaft (power take-off) out of the housing bore.



73073TM180

- ⑫ Squeeze rectangular ring (arrow) out and separate ball bearing from shaft.

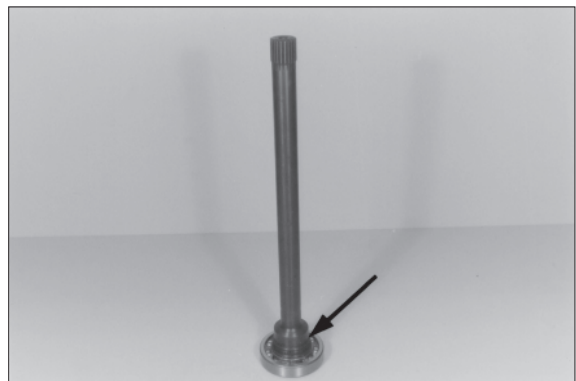

73073TM179

- ※ If contrary to the recommendation, the tapered roller bearings of the clutches as well as of the input and output would not be renewed, the allocation of the inner and outer races to the single assemblies must at least be maintained.
- ※ Mark bearing inner and outer races accordingly.

(8) Disassemble KV and KR clutch

※ The following figures show the disassembly of the KV clutch.

The disassembly of the KR clutch is analogous.

① Squeeze rectangular ring (arrow) out.

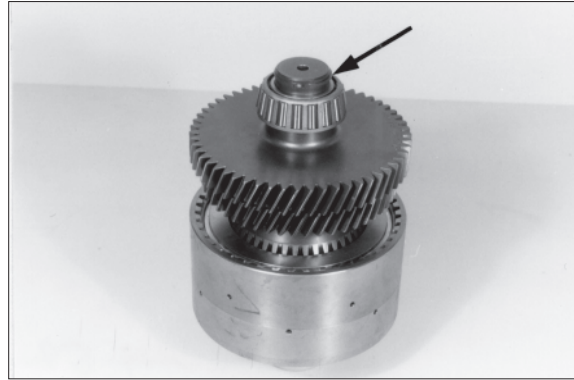

73073TM54

② Pull tapered roller bearing from the shaft.
Demount opposite tapered roller bearing accordingly.

※ Special tool

Grab sleeve 5873 001 057

Basic set 5873 001 000



73073TM55

③ Separate plate carrier from shaft.

※ Special tool

Hammer 5870 280 004



73073TM56

④ Squeeze snap ring out and remove plate pack.



73073TM57

- ⑤ Preload compression spring, squeeze circlip out and remove components.

※ Special tool

Assembly aid 5870 345 086

Set of external pliers 5870 900 015



73073TM58

- ⑥ Lift piston by means of compressed air out of the cylinder bore and remove it.

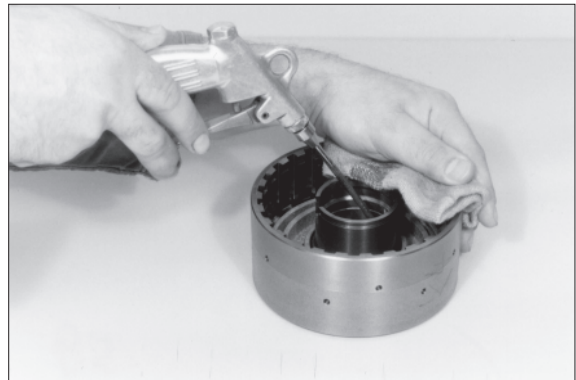

73073TM59

- ⑦ Remove both O-rings.

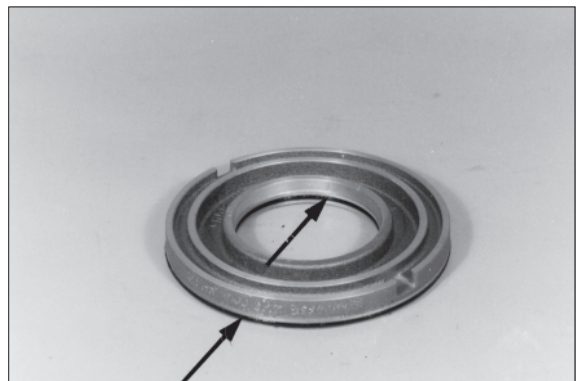

73073TM60

- ⑧ Squeeze inner circlip (shaft) out.

※ Special tool

Set of external pliers 5870 900 015



73073TM61

- ⑨ Locate idler gear by means of separating device(See on the right figure) and press it from the shaft(See on the below figure).
Remove released needle bearing.

※ Special tool

Separating device 5870 300 028

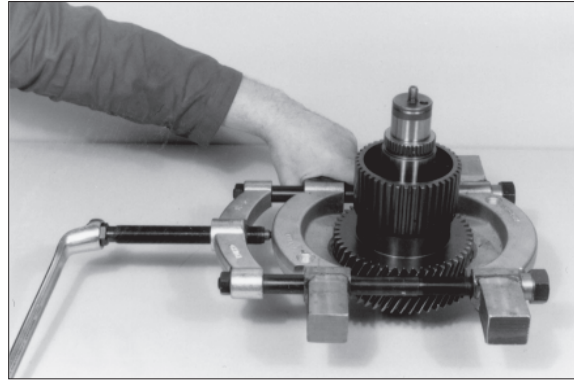

73073TM62

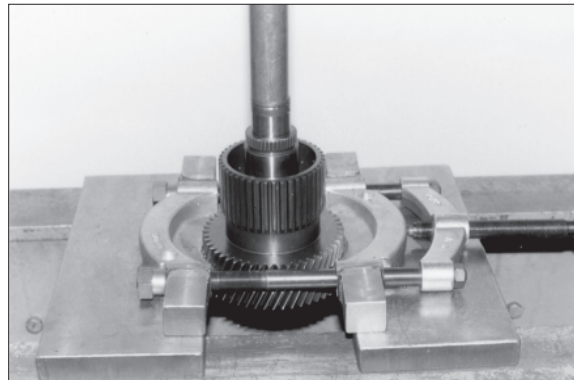

73073TM63

- ⑩ Squeeze circlip out and remove ball bearing.

※ The disassembly of the KR clutch has to be carried out accordingly.

※ Special tool

Set of internal pliers 5870 900 013

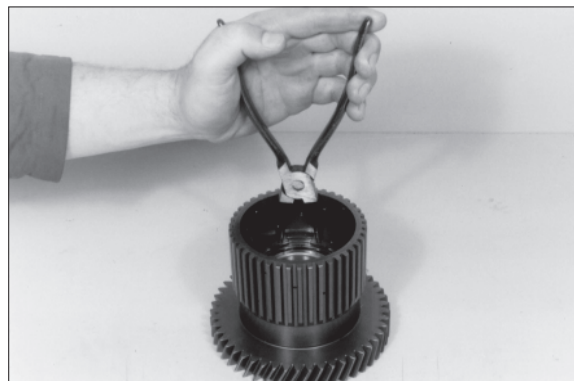

73073TM64

(9) Disassemble K1, K2 and K3 clutch

※ The following Figures show the disassembly of the K3 clutch.

The disassembly of the K1 and K2 clutches is analogous.

- ① Squeeze rectangular ring(Arrow) out.



73073TM65

- ② Pull tapered roller bearing from the shaft.
Remove opposite tapered roller bearing accordingly, see Figure ① , ②.

※ Special tool

Grab sleeve 5873 001 057

Grab sleeve 5873 001 058

(K3 on output side)

Basic set 5873 001 000

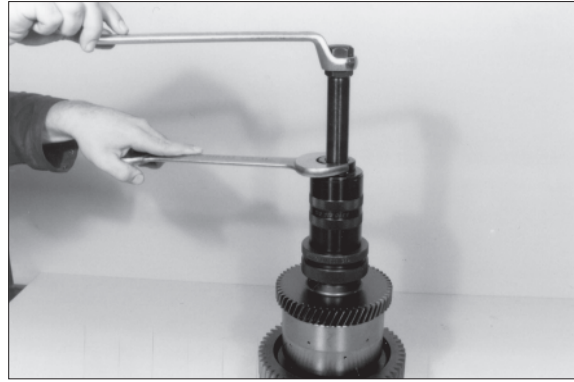

73073TM66

- ③ Remove running disk, axial needle cage and axial washer.

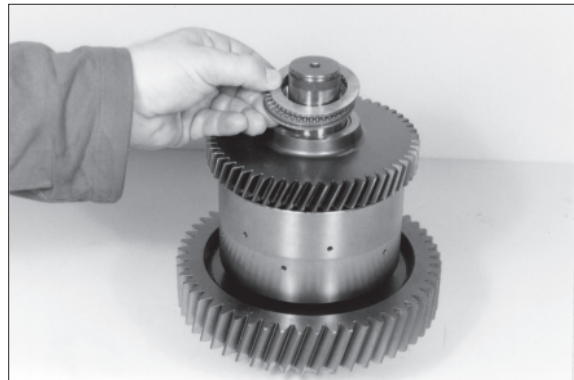

73073TM67

- ④ Remove idler gear.



73073TM68

- ⑤ Remove both needle bearings as well as axial bearing.

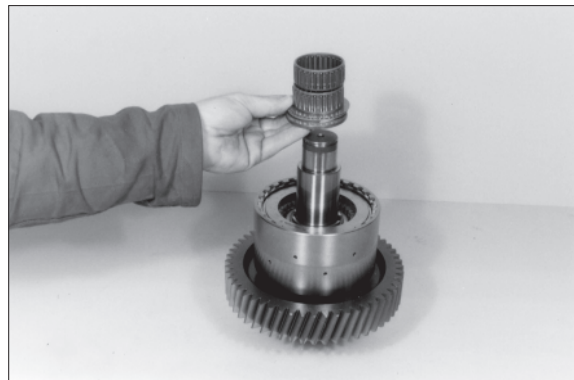

73073TM69

- ⑥ Squeeze snap ring out and remove plate pack.

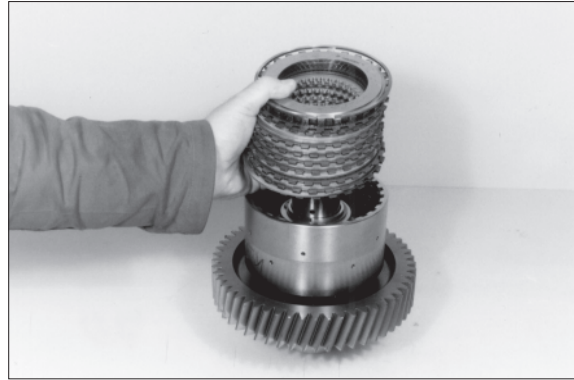

73073TM70

- ⑦ Preload compression spring, squeeze circlip out and remove components.

※ Special tool

Assembly aid(K2 and K3) 5870 345 085

Assembly aid(K1) 5870 345 086

Set of external pliers 5870 900 015



73073TM71

- ⑧ Press piston out of the plate carrier, using compressed air.

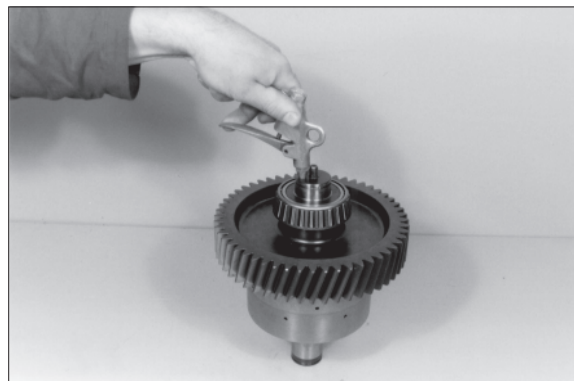

73073TM72

- ⑨ Pry plate carrier from the shaft.

※ Special tool

Pry bar 5870 345 065



73073TM73

(10) Disassemble K4 clutch

- ① Squeeze rectangular ring out and pull tapered roller bearing from the shaft.
Remove opposite tapered roller bearing accordingly.

※ Special tool

Grab sleeve 5873 001 057

Basic set 5873 001 000

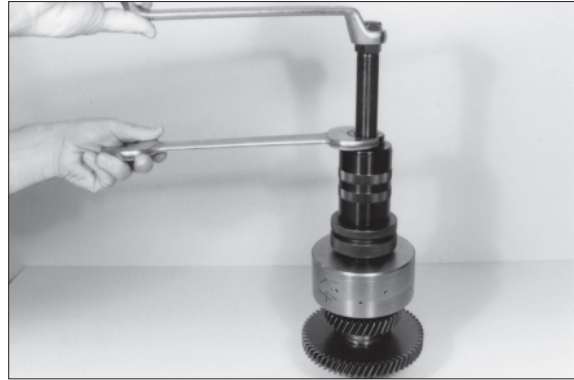

73073TM74

- ② Squeeze circlip out and separate plate carrier from the shaft.

※ Special tool

Assembly aid 5870 345 085

Set of external pliers 5870 900 015



73073TM75

- ③ Squeeze snap ring out and demount plate pack.

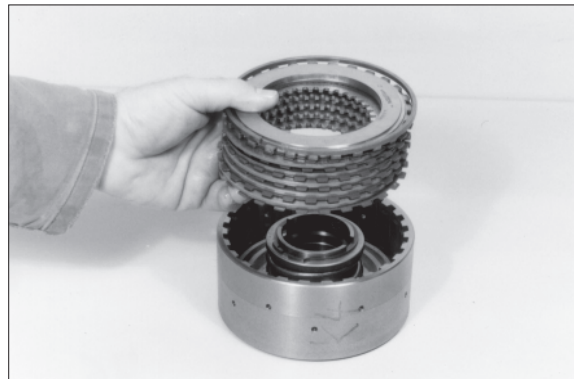

73073TM76

- ④ Preload compression spring, squeeze circlip out and remove components.
Demount piston.

※ The separation of shaft and gear is not possible (shrink fit).

※ Special tool

Assembly aid 5870 345 085



73073TM77

(11) Disassemble input shaft

- ① If necessary, press turbine shaft out of the input shaft.
- ※ The turbine shaft is axially fixed by means of a snap ring which will be destroyed at the pressing out.

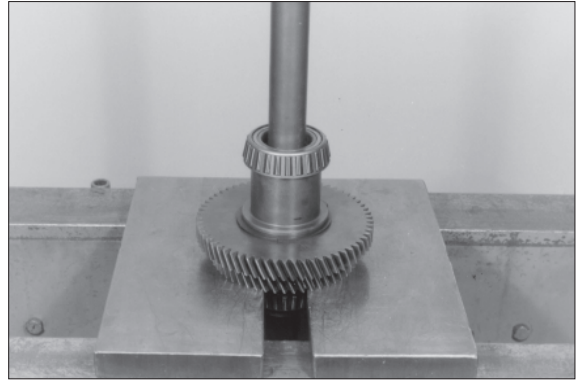

73073TM78

- ② Squeeze rectangular ring out and pull off the tapered roller bearing.
Pull off the opposite tapered roller bearing.
- ※ The separation of input shaft 1 and gear 2 is not possible (shrink fit).
- ※ Special tool
 - Grab sleeve 5873 001 058
 - Basic set 5873 001 000

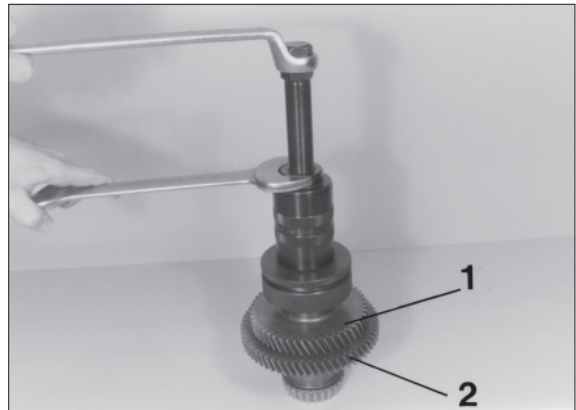

73073TM79

2) ASSEMBLY

- ※ If contrary to the recommendation, the tapered roller bearings of the clutches as well as of the input and output would not be renewed, the allocation of the inner and outer races to the single assemblies must at least be maintained.

(1) Mount oil pipes

- ※ To ensure the correct assembly of the oil pipes, the use of the specified special tool is imperative.

① Install studs (arrows).

- Torque limit : 0.92 kgf · m (6.64 lbf · ft)

- ※ Insert studs with loctite.

② Place distance tubes over the studs.

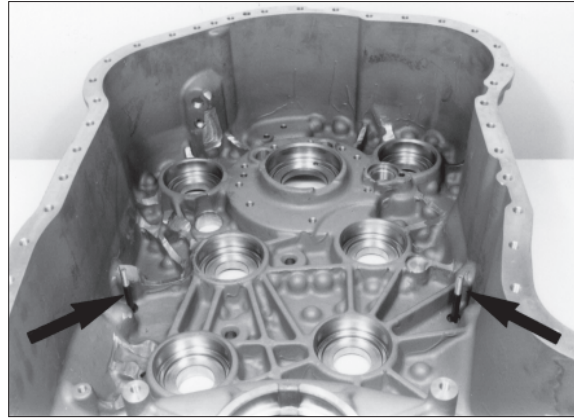

73073TM090



73073TM091

③ Insert suction tube 1, pressure pipe 2 and pressure pipe lubrication 3 into the housing bores.

Fasten suction tube 1 and pressure pipes 2 provisionally by means of socket head screw and hexagon nuts.

- Torque limit : 2.35 kgf · m (17.0 lbf · ft)

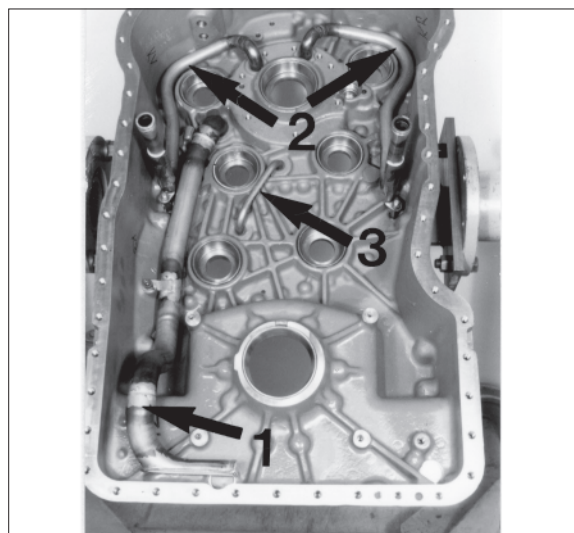

73073TM092

④ Locate both pressure pipes by means of special device.

※ Special tool

Tension bar

5870 654 030

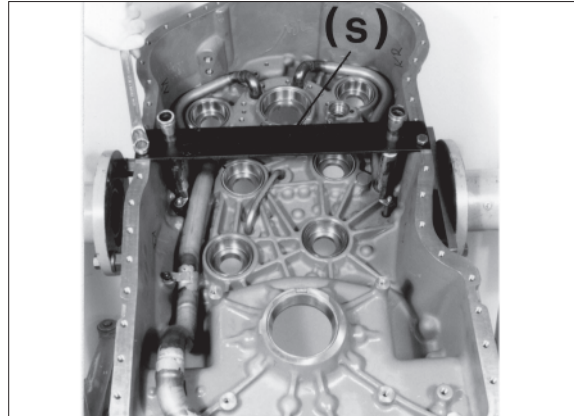

73073TM093

⑤ Tilt housing 180°.

Roll in suction tubes as well as pressure pipes (arrows) into the housing bores, using special tool.

※ Pipe end of pressure pipes (arrows) must be slightly below the housing plane face, if necessary equalize.

※ Special tool

Rolling tool

5870 600 003

Rolling too

5870 600 004

Rolling too

5870 600 005

Rolling too

5870 600 006

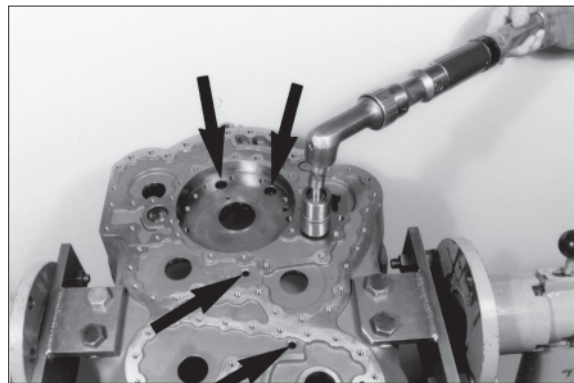

73073TM094

⑤ Tilt housing 180°.

Check installation position of the two pressure pipes and correct if necessary.

※ Pipes must be located in the special device without play and pressure.

Now, remove special device.

※ Special tool

Tension bar

5870 654 030

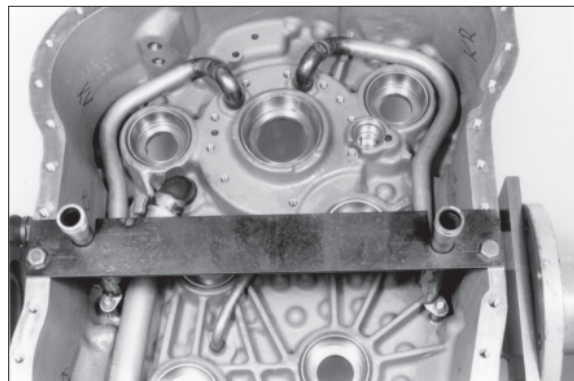

73073TM095

⑥ Equip screw plug with new O-ring and install it.

· Torque limit : 5.2 kgf · m (37.6 lbf · ft)

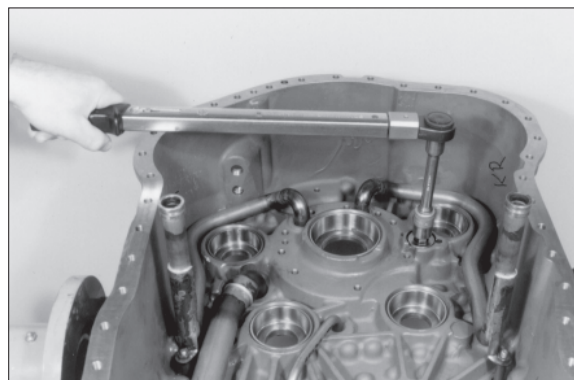

73073TM096

⑦ Insert all bearing outer races into the housing bore.

※ In the case that already run bearings are reused, pay attention to the allocation of the bearing outer races, see also Note, page 3-101.

※ Pay attention to the corresponding markings.

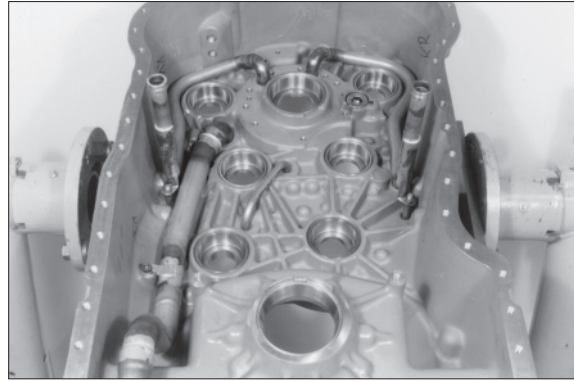

73073TM097

⑧ Insert both oil pipes (Arrows) into the housing cover, tilt housing cover 180° and roll in oil pipes into the housing bores.

※ The pipe end must be situated slightly below the housing plane face.

※ Special tool

Rolling tool 5870 600 005

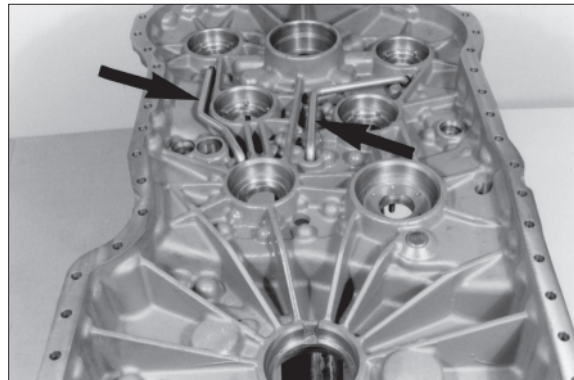

73073TM098

⑨ Install studs (M8 × 25, 27EA) according to the figure on the right.

· Torque limit : 0.92 kgf · m (6.64 lbf · ft)

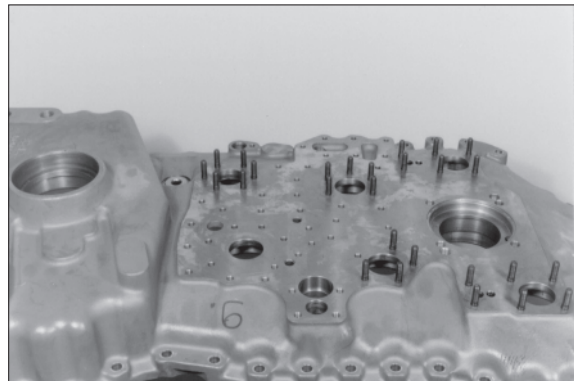

73073TM099

⑩ Insert set screws (2EA) into the housing bores (arrows).

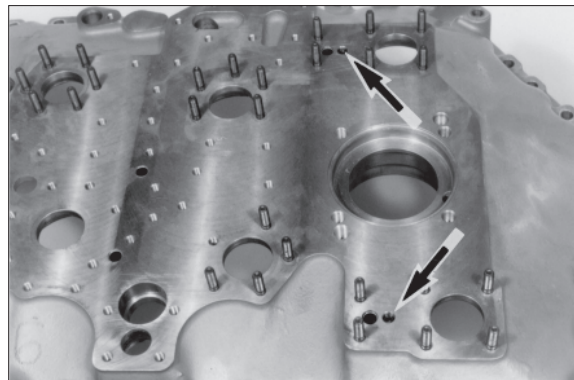

73073TM099A

Assemble KV and KR clutch

The following figures describe the assembly of the KV clutch.

Pre-assemble plate carrier (figure ⑪~⑭)

⑪ Check function of the drain valve.

※ Ball may not seize, if necessary clean by means of compressed air.

Insert both O-rings (arrows) scroll free into the recesses of the piston and oil them.

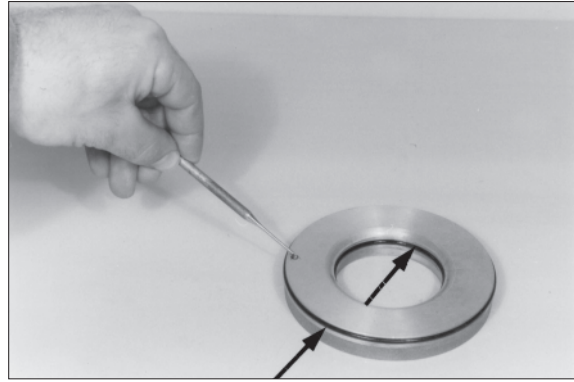

73073TM100

⑫ Assemble piston until contact is obtained.

※ Pay attention to the installation position, see on the right figure.

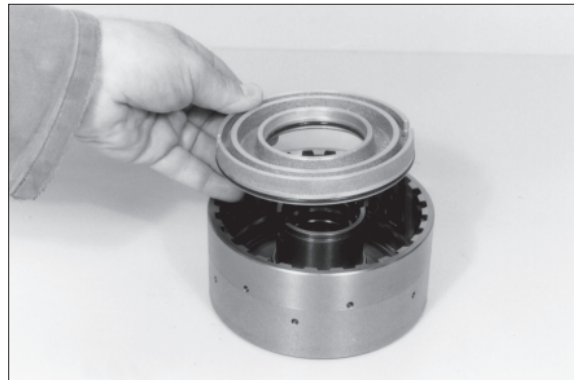

73073TM101

⑬ Introduce compression spring along with spring cup (2EA).

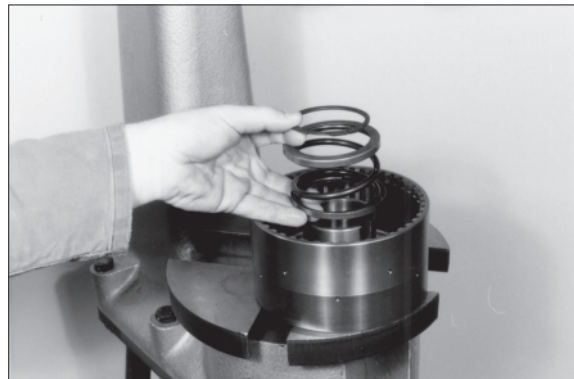

73073TM102

⑭ Preload compression spring and fix it by means of circlip.

※ Special tool

Assembly aid

5870 345 086



73073TM103

KV, KR plate pack

- ※ The plate equipment, respectively stacking of KV and KR clutch is identical. The following draft shows the installation position of the components.

- 1 Plate carrier
- 2 Piston
- 3 Outer plate-one-sided coated
- 4 Inner plates
- 5 Outer plates-coated on both sides
- 6 Snap ring (optional $s = 2.1 \sim 4.2$ mm)
- 7 End shim

- ※ Install outer plate 3 with the uncoated side facing the piston, respectively the end shim.

Install on the end shim side two outer and inner plates each.

- Effective number of friction surfaces = 20.

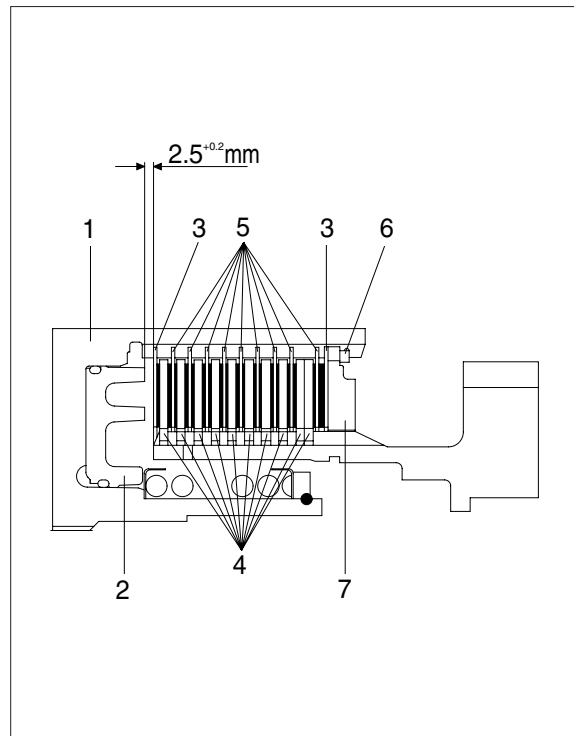

73033TM13

- ⑮ Adjust plate clearance = $2.5^{+0.2}$ mm.

- ※ For the adjustment of the plate clearance there are snap rings of different thickness available.

To ensure a faultless measuring result, install plates for the moment without oil.

- ※ Introduce plate pack according to the upper draft.

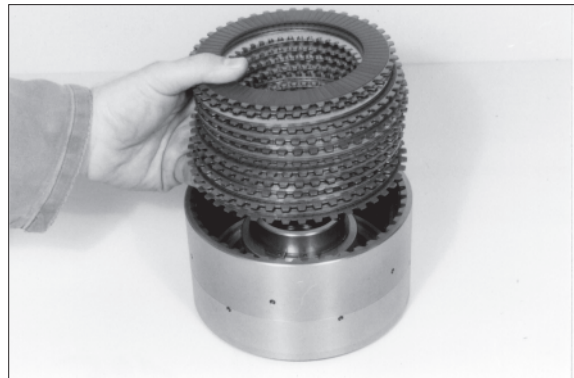

73073TM105

- ⑩ Mount end shim and squeeze snap ring (e.g. $s = 3.0$ mm) in.

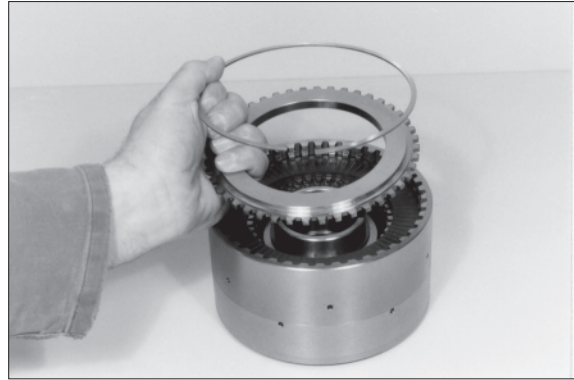

73073TM106

- ⑪ Press end shim on with about 10kg and measure Dimension I from the end face/plate carrier to the end shim.

Dimension I e.g. 7.25 mm

- ※ Special tool

Digital-Depth gauge 5870 200 072

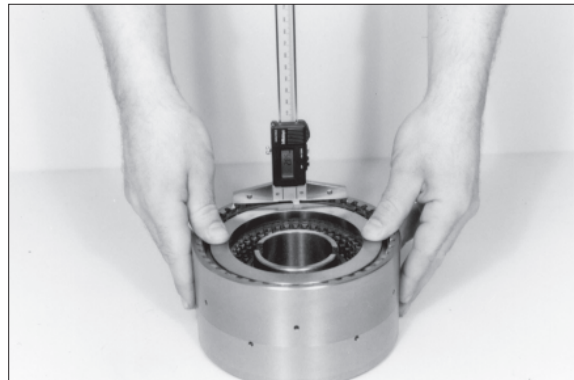

73073TM107

- ⑫ Press end shim against snap ring (Upward) until contact is obtained and determine Dimension II.

Dimension II e.g. 4.75 mm

- ※ Special tool

Digital-Depth gauge 5870 200 072

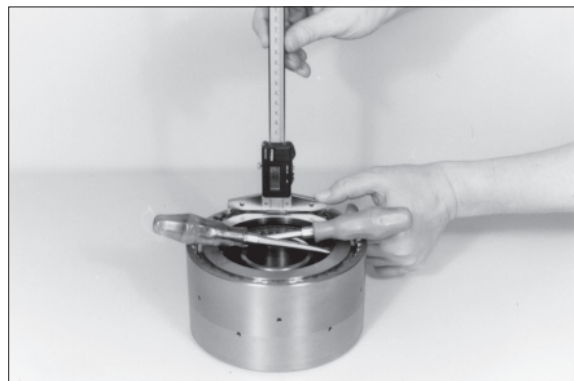

73073TM108

EXAMPLE

Dimension I 7.25 mm

Dimension II - 4.75 mm

Difference = Plate clearance = 2.50 mm

- ※ In case of deviations from the required plate clearance, correct by means of corresponding snap ring ($s = 2.1 \sim 4.2$ mm).

Now, remove plate pack, oil and install it again.

- ①⑨ Introduce idler gear until all inner plates are accommodated.
※ This step makes the later assembling of the idler gear easier.
Now, remove idler gear again.

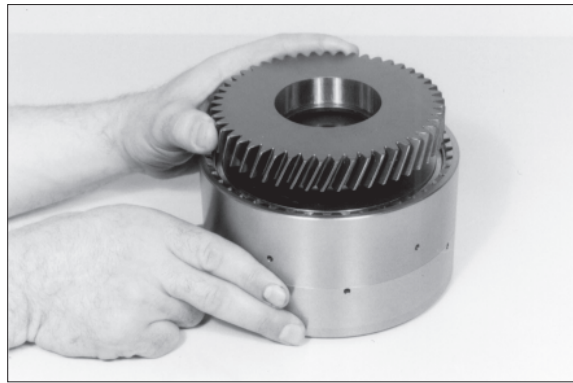

73073TM109

- ②⑩ Install stud (arrow).
※ Use loctite.
• Torque limit : 1.73 kgf · m (12.5 lbf · ft)



73073TM110

- ②⑪ Insert ball bearing until contact is obtained and fix it by means of circlip.



73073TM111

- ②⑫ Assemble needle bearing.

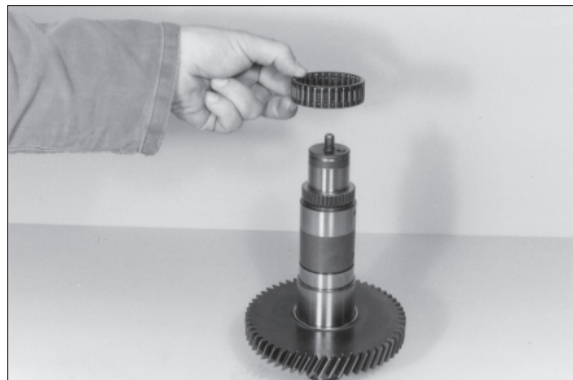

73073TM112

- ②③ Press idler gear against shoulder.
※ Support it on the bearing inner race.



73073TM113

- ②④ Fix idler gear axially by means of circlip.
※ At KR clutch there is no recess in the shaft-assembly circlip until contact on the bearing inner race is obtained.
※ Special tool
Set of internal pliers 5870 900 013

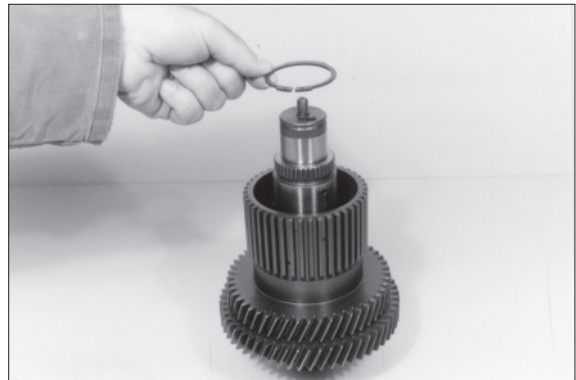

73073TM114

- ②⑤ Assemble pre-assembled plate carrier until contact is obtained.
※ Only if the plate carrier plane face is overlapping with the shaft collar, the accommodation of all inner plates is ensured, see on the below figure.



73073TM115

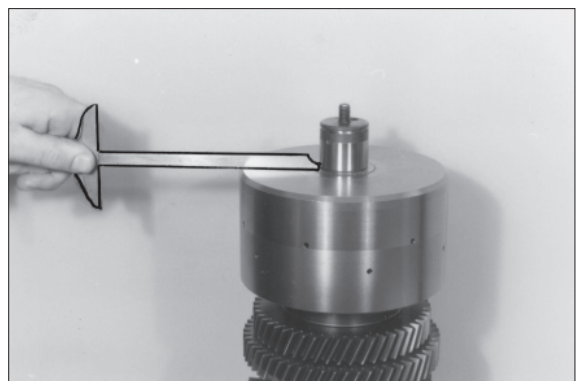

73073TM116

- ②⑥ Press tapered roller bearing against shoulder.
Install opposite tapered roller bearing.



73073TM117

- ②⑦ Check function of clutch by means of compressed air.
※ At correctly installed components, the closing, respectively opening of the clutch is clearly audible.

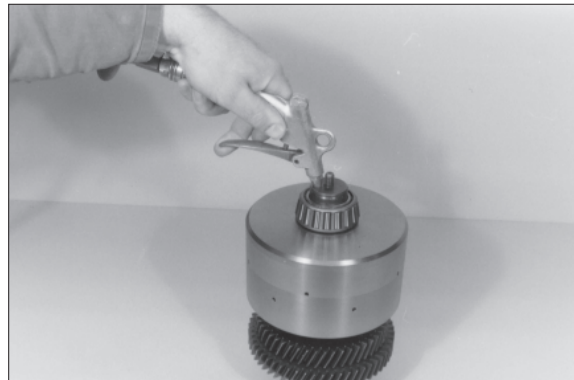

73073TM118

(2) Assemble K1, K2 and K3 clutch

- ※ The following figures describe the assemble of the K3 clutch.
The assembly of the K1 and K2 clutches has to be carried out accordingly.

- ① Install stud (arrow).
※ Use loctite.
· Torque limit : 1.73 kgf · m (12.5 lbf · ft)



73073TM125

- ② Assemble plate carrier until contact is obtained.

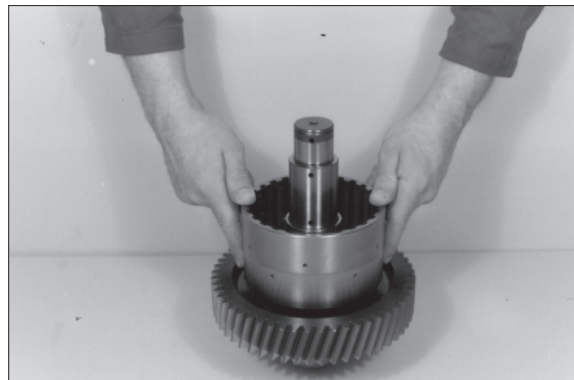

73073TM126

- ③ Check function of the drain valve.
- ※ Ball may not seize, if necessary clean by means of compressed air.
- Insert both O-rings (arrows) scroll free into the piston recesses and oil them.

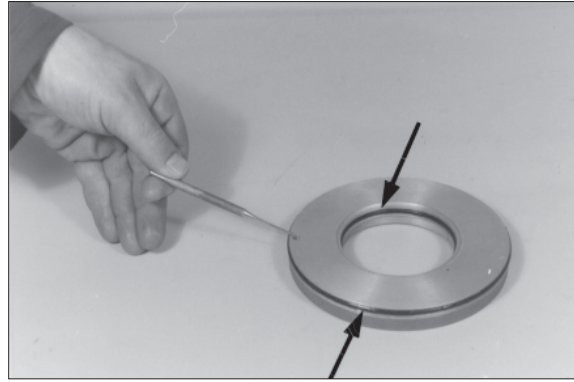

73073TM127

- ④ Introduce piston until contact is obtained.
- ※ Pay attention to the installation position, see on the right figure.

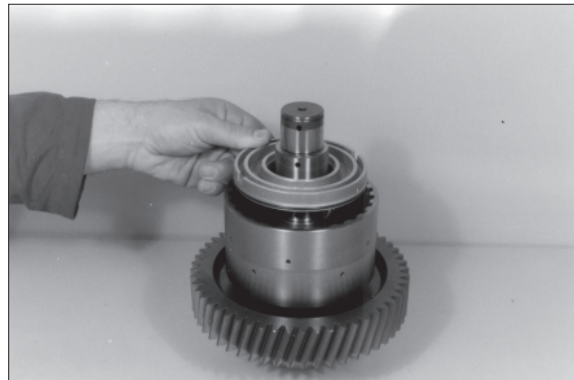

73073TM128

- ⑤ Introduce compression spring along with spring cup (2EA).

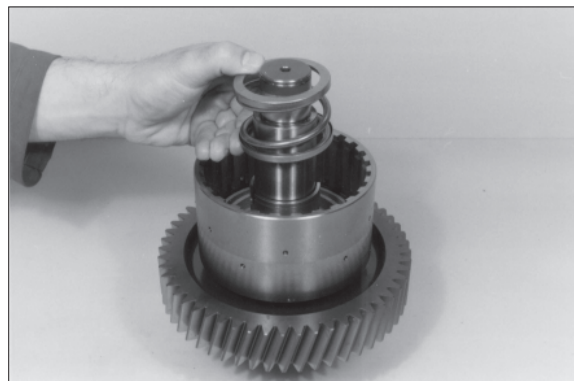

73073TM129

- ⑥ Preload compression spring and fix it by means of circlip.
- ※ Special tool
- Assembly aid(K2 and K3) 5870 345 085
- Assembly aid(K1) 5870 345 086



73073TM130

K1, K2 and K3 plate pack

- ※ The K1, K2 and K3 plate stacking of clutches are identical.

The following draft shows the installation position of the components.

- 1 Plate carrier
- 2 Piston
- 3 Outer plate-one-sided coated
- 4 Inner plates
- 5 Outer plates-coated on both sides
- 6 Snap ring(Optional $s = 2.1\sim 4.2\text{mm}$)
- 7 End shim

- ※ Install outer plate 3 with the uncoated side facing the piston.
 - Effective number of the friction surfaces = 16.

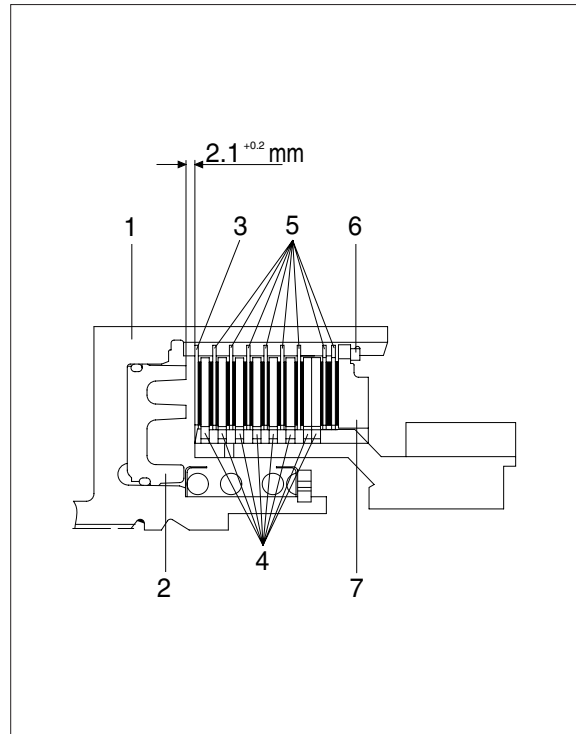

73033TM15

- ⑦ Adjust plate clearance = $2.1^{+0.2}$ mm :

- ※ For the plate clearance adjustment there are snap rings of different thickness available.

To ensure a faultless measuring result, install the plates for the moment without oil.

- ※ Introduce plate pack according to the upper draft.

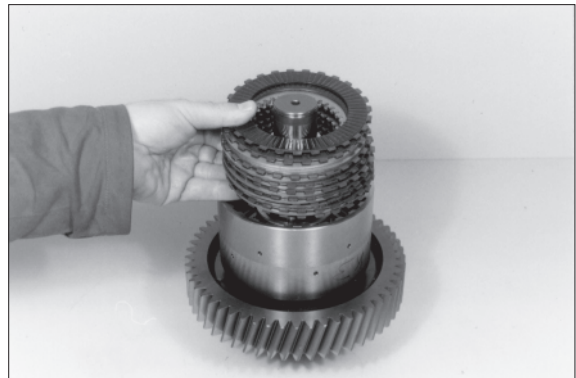

73073TM135

- ⑧ Fit end shim and squeeze snap ring (e.g. 3.0 mm) in.



73073TM136

- ⑨ Press end shim on with about 10kg, and measure Dimension I from the end face/plate carrier to the end shim.

Dimension I e.g. 8.20 mm

※ Special tool

Digital-Depth gauge 5870 200 072

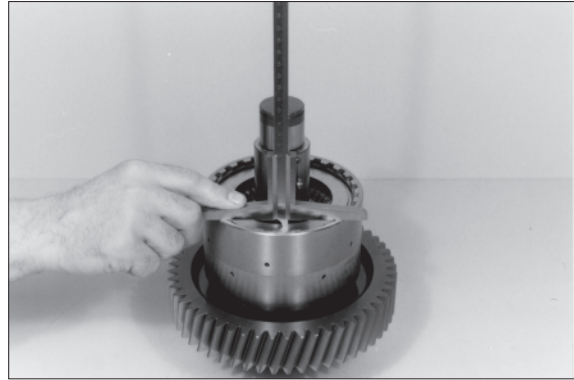

73073TM137

- ⑩ Press end shim against snap ring(Upward) until contact is obtained, and determine Dimension II .

Dimension II e.g. 6.00 mm

※ Special tool

Digital-Depth gauge 5870 200 072

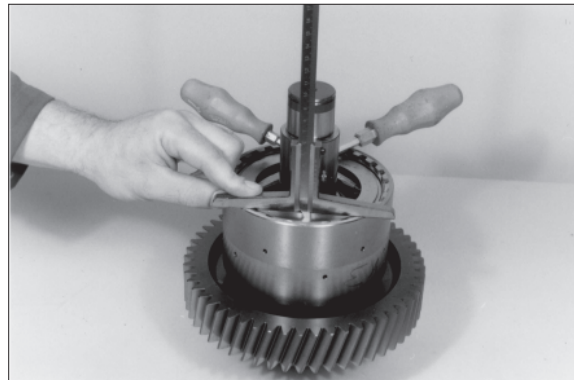

73073TM138

EXAMPLE :

Dimension I e.g. 8.20 mm

Dimension II e.g. - 6.00 mm

Difference = Plate clearance = 2.20 mm

- ※ In case of deviations from the required plate clearance, correct by means of corresponding snap ring(S =2.1~4.2 mm).
 ※ Now, demount plate pack, oil and install it again.

- ⑪ Assemble running disk 1(50×70×4), axial needle cage 2 and axial washer 3 (50×70×1).

※ Install running disk 1 with the chamfer facing the axial needle cage.

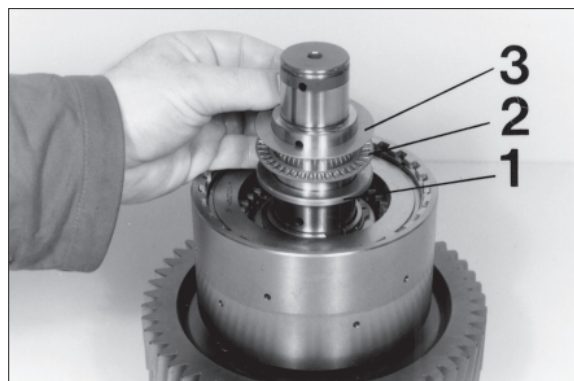

73073TM139

⑫ Assemble both needle bearings.



73073TM140

⑬ Introduce idler gear until all inner plates are accommodated.



73073TM141

⑭ Assemble axial washer 3(50×70×1), axial needle cage 2 and running disk 1 (50×70×4).

- ※ Install running disk 1 with the chamfer facing the axial needle cage.
- ※ Only if the running disk is overlapping with the shaft collar, the accommodation of all inner plates is ensured.

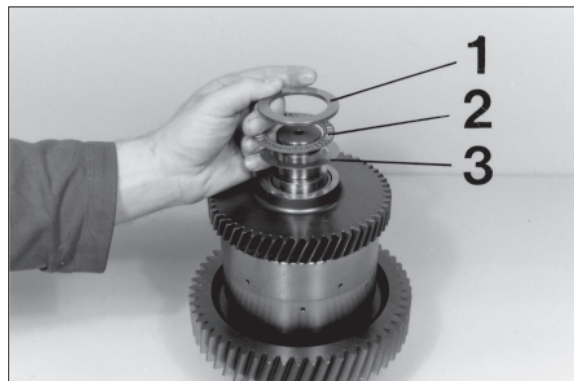

73073TM142

⑮ Press tapered roller bearing against shoulder.

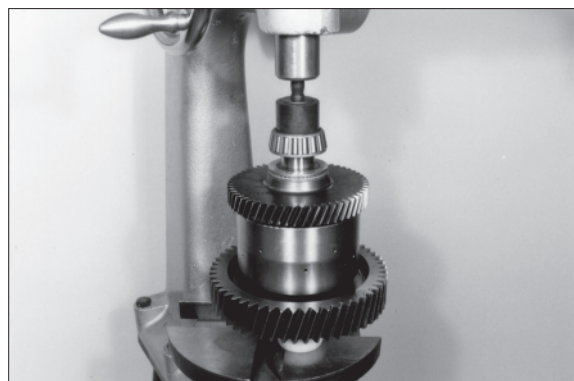

73073TM143

- ⑩ Press tapered roller bearing against shoulder.

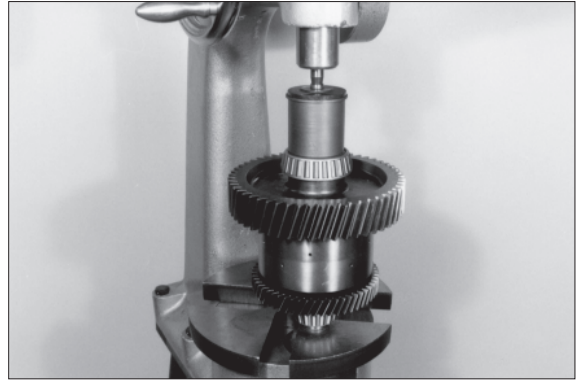

73073TM144

- ⑪ Check function of the clutch by means of compressed air.
- ※ At correctly installed components, the closing, respectively opening of the clutch is clearly audible.

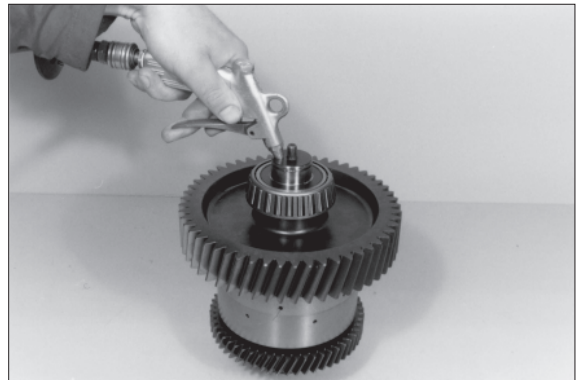

73073TM145

(3) Assemble K4 clutch

- ① Undercool shaft (about -80°C), heat gear (about $+120^{\circ}\text{C}$) and assemble it until contact is obtained.

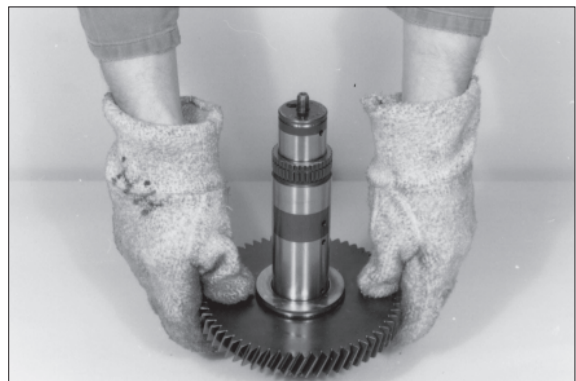

73073TM150

- ② Locate gear axially by means of circlip.
- ※ Special tool
Set of external pliers 5870 900 015



73073TM151

③ Install stud (arrow).

※ Use loctite.

• Torque limit : 1.73 kgf · m (12.5 lbf · ft)



73073TM152

④ Check function of the drain valve.

※ Ball may not seize, if necessary clean by means of compressed air.

Insert both O-rings (arrows) scroll free into the piston recesses and oil them.

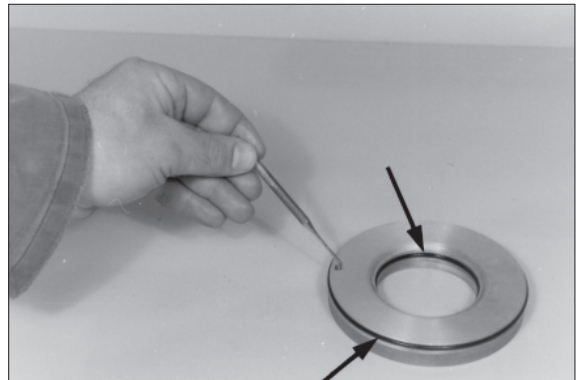

73073TM153

⑤ Introduce piston until contact is obtained.

※ Pay attention to the installation position, see on the right figure.

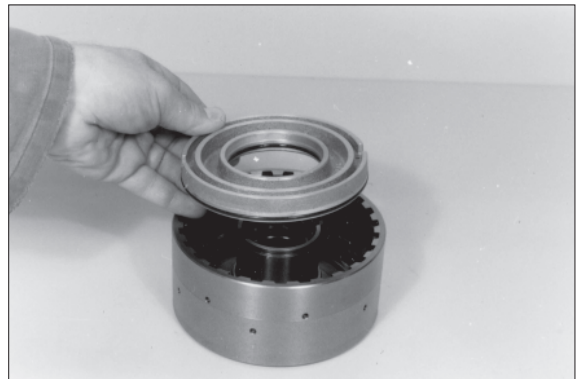

73073TM154

⑥ Install compression spring and spring cup (2EA), preload and fix by means of circlip.

※ Special tool

Assembly aid

5870 345 085



73073TM155

K4 plate pack

The following draft shows the installation position of the components.

- 1 Plate carrier
- 2 Piston
- 3 Outer plate-one-sided coated
- 4 Inner plates
- 5 Outer plates-coated on both sides
- 6 Snap ring (optional $s = 2.1\sim 4.2$ mm)
- 7 End shim

- ※ Install outer plate 3 with the uncoated side facing the piston.
 - Effective number of friction surfaces = 10.

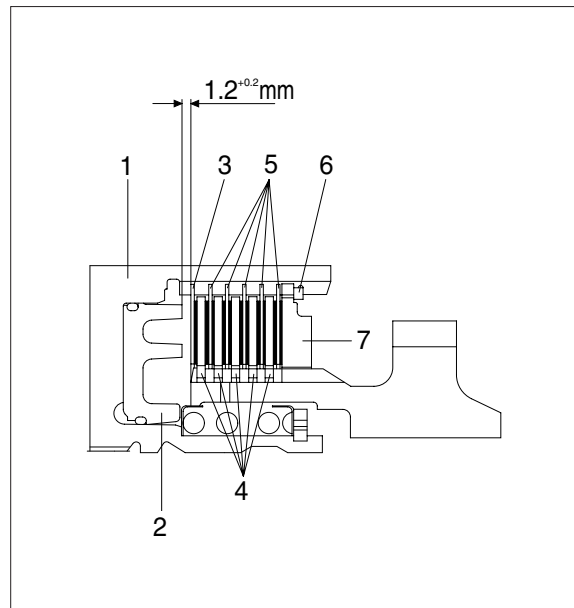

73033TM16

- ⑦ Adjust plate clearance = $1.2^{+0.2}$ mm :

- ※ For the plate clearance adjustment there are snap rings of different thickness available.

To ensure a faultless measuring result, install the plates for the moment without oil.

Introduce plate pack according to the draft (see the preceding page).

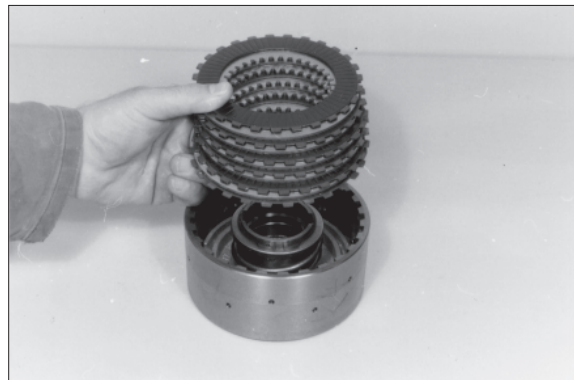

73073TM160

- ⑧ Fit end shim and squeeze circlip (e.g. $s = 3.0$ mm) in.

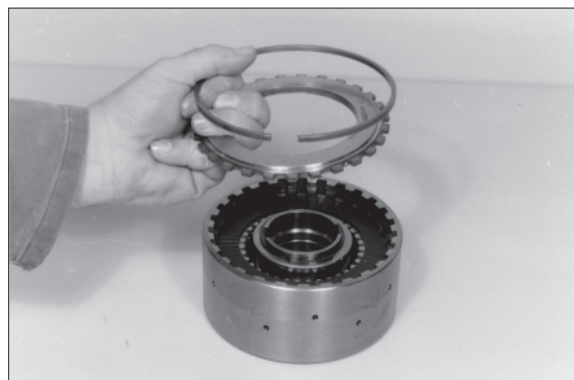

73073TM161

- ⑨ Press end shim on with about 10kg and measure Dimension I from the end face/plate carrier to the end shim.

Dimension I e.g. 7.20 mm

※ Special tool

Digital-Depth gauge 5870 200 072

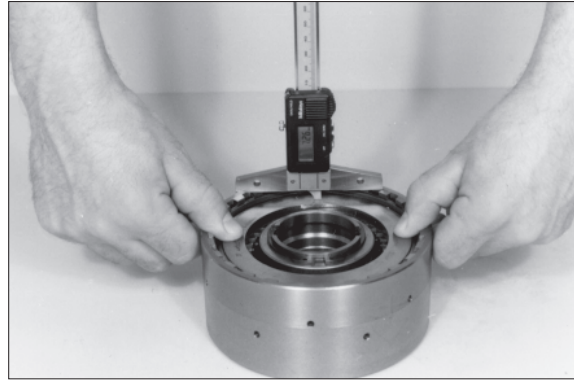

73073TM162

- ⑩ Press end shim against snap ring (Upward) until contact is obtained and determine Dimension II.

Dimension II e.g. 6.00 mm

※ Special tool

Digital-Depth gauge 5870 200 072

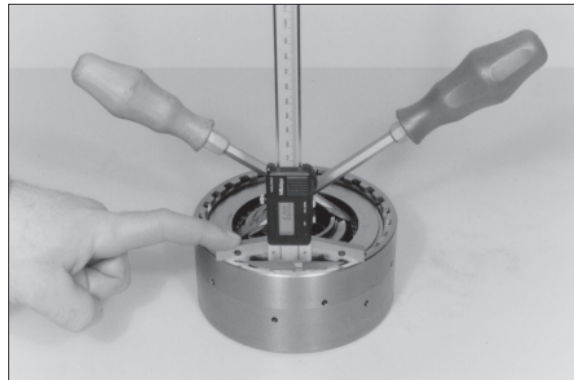

73073TM163

EXAMPLE

Dimension I e.g. 7.20 mm

Dimension II e.g. - 6.00 mm

Difference = Plate clearance = 1.20 mm

- ※ In case of deviations from the required plate clearance, correct by means of corresponding snap ring (S = 2.1~4.2 mm).

- ⑪ Introduce idler gear until all inner plates are accommodated.

- ※ This step makes the later assembling of the idler gear easier.

Now, remove idler gear again.

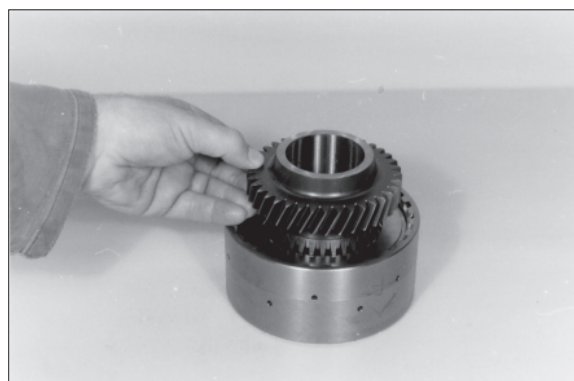

73073TM164

- ⑫ Assemble both axial washers as well as needle cage.
- ※ Upper and lower axial washer have the same thickness(50×70×1).

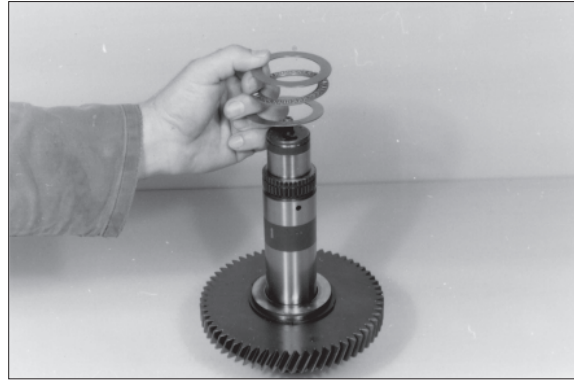

73073TM165

- ⑬ Assemble both needle bearings.

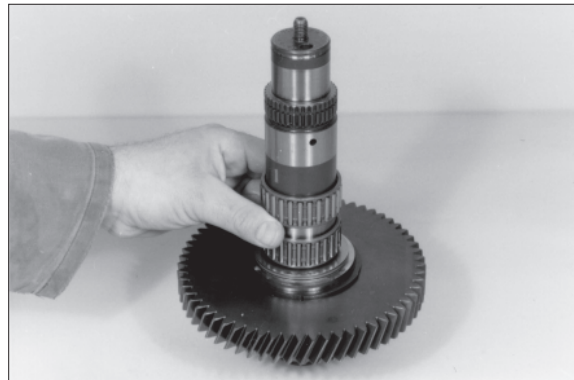

73073TM166

- ⑭ Assemble idler gear.

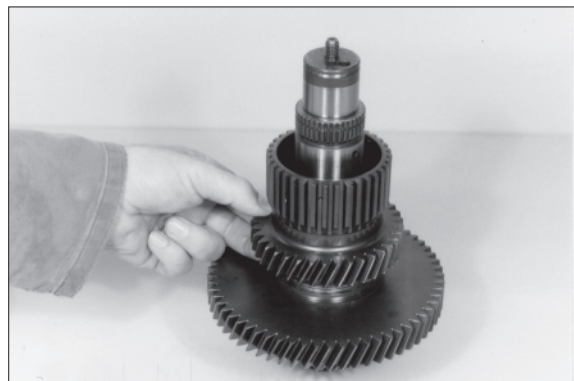

73073TM167

- ⑮ Assemble axial washer 3 (50×70×1) needle cage 2 and running disk 1 (50×70×4).
- ※ Install running disk 1 with the chamfer facing the needle cage.

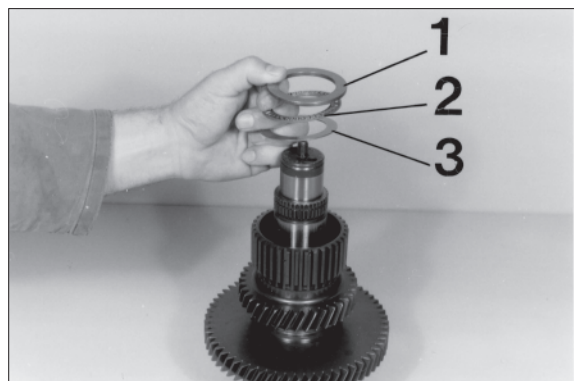

73073TM168

- ⑩ Assemble pre-assembled plate carrier until all inner plates are accommodated.

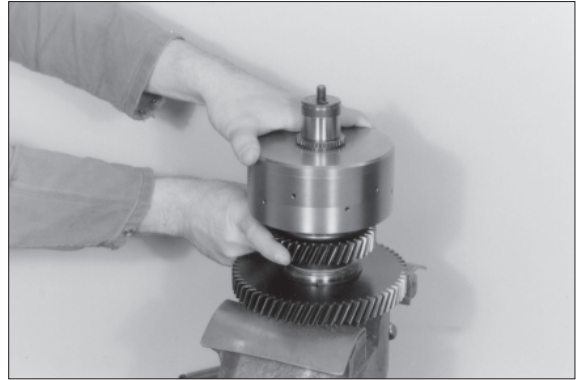

73073TM169

- ⑪ Fix plate carrier axially by means of circlip.

※ Special tool

Set of external pliers 5870 900 015

Handle 5870 260 010



73073TM170

- ⑫ Press tapered roller bearing against shoulder.
Install opposite tapered roller bearing.

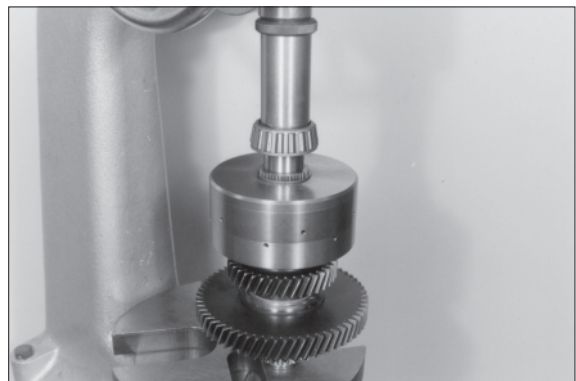

73073TM171

- ⑬ Check function of the clutch by means of compressed air.

※ At correctly installed components, the closing, respectively opening of the clutch is clearly audible.



73073TM173

(4) Pre-assemble input shaft

- ① Undercool the input shaft (about -80°C), heat gear (about $+120^{\circ}\text{C}$) and assemble it until contact is obtained.

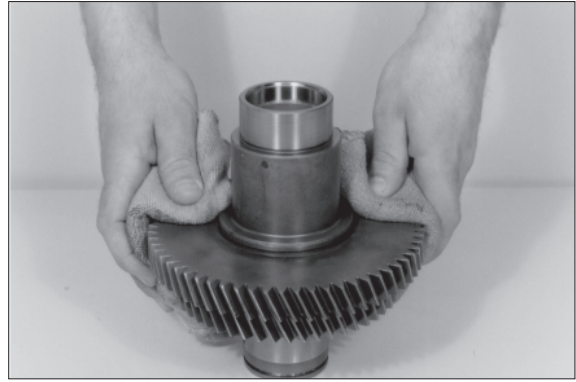

73073TM174

- ② Fix gear axially by means of circlip.

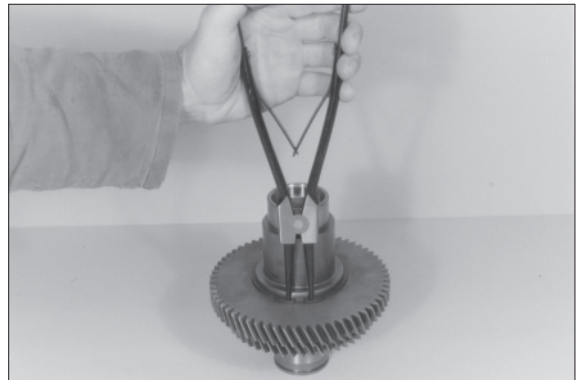

73073TM175

- ③ Squeeze snap ring into the recess of the turbine shaft.



73073TM176

- ④ Introduce turbine shaft until the snap ring snaps into the recess of the input shaft-turbine shaft is axially fixed.



73073TM177

- ⑤ Press both bearing inner races against shoulder.

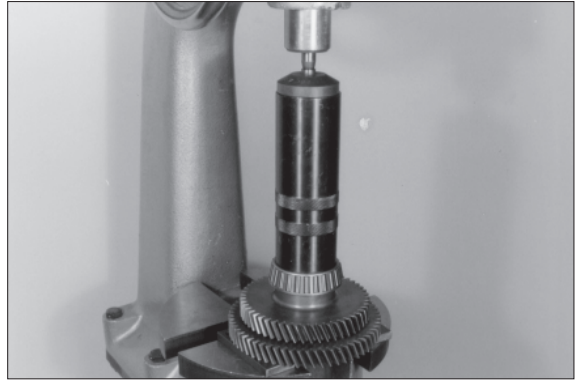

73073TM178

- ⑥ Install ball bearing.
Squeeze rectangular ring (arrow) in and hook it in.

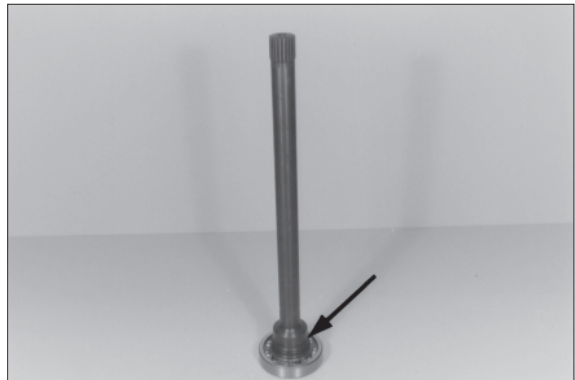

73073TM179

- ⑦ Insert output shaft into the housing bore until contact is obtained.



73073TM180

(5) Install pre-assembled output shaft and clutches

※ The following figures describe the common installation of all clutches.

For it, the housing cover, combined with special tool is needed.

The assembly of single clutches without housing cover and handles is extremely difficult because of the installation conditions.

▲ Besides, there is the danger of injury.

① Insert all bearing outer races into the housing cover until contact is obtained.

※ In the case that already run bearings are reused, pay attention to the allocation of the bearing outer races, see also Note, page 3-101.

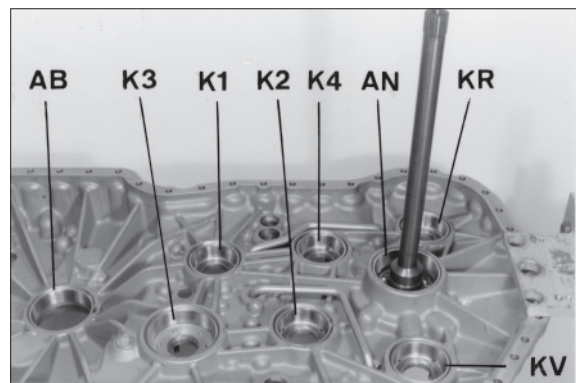

② Insert KR clutch, input shaft and KV clutch together into the housing cover.

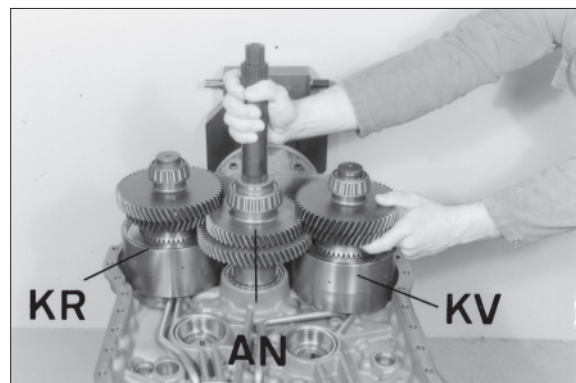

③ Install K4 clutch.

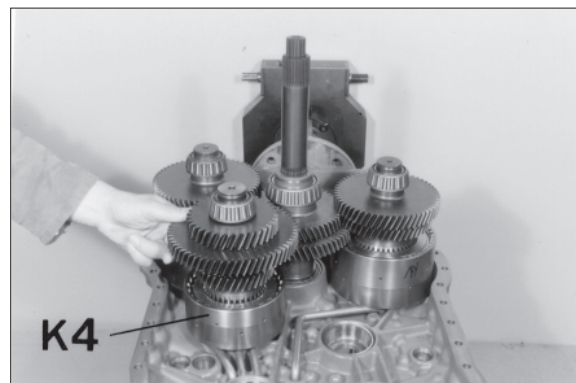

④ Install K3 clutch.

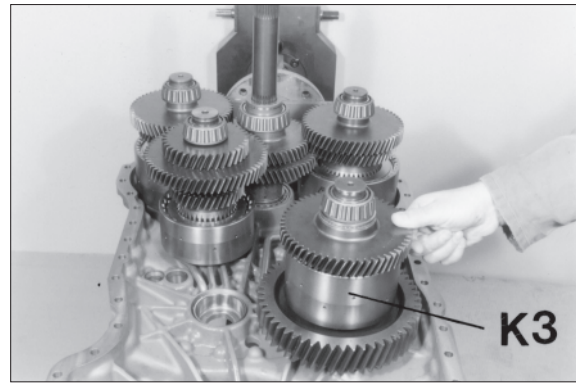

73073TM193

⑤ Position K1 clutch.



73073TM194

⑥ Insert K2 clutch.

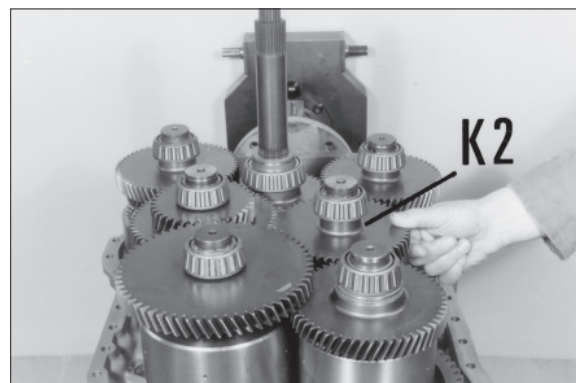

73073TM195

⑦ Figure on the right shows the installation position of the single clutches in the housing cover.

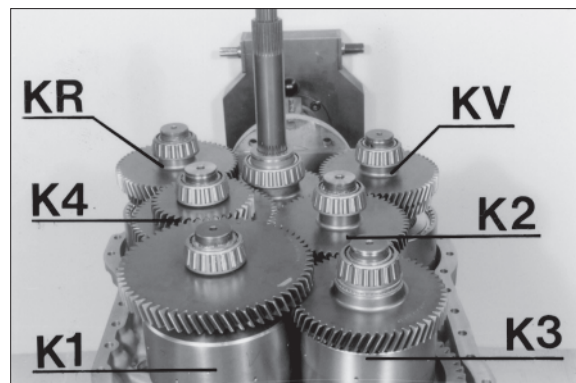

73073TM196

- ⑧ Locate all clutches by means of handles.
- ※ Special tool
Handle(6EA needed) 5870 260 010

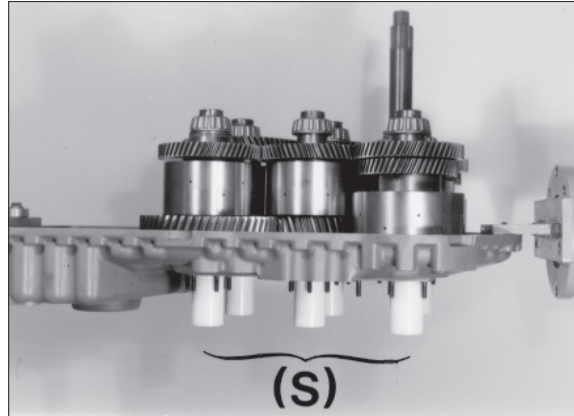

73073TM197

- ⑨ Squeeze rectangular rings (7 pieces, see arrows) in and hook them in.
Now, grease rectangular rings and align them centrally.

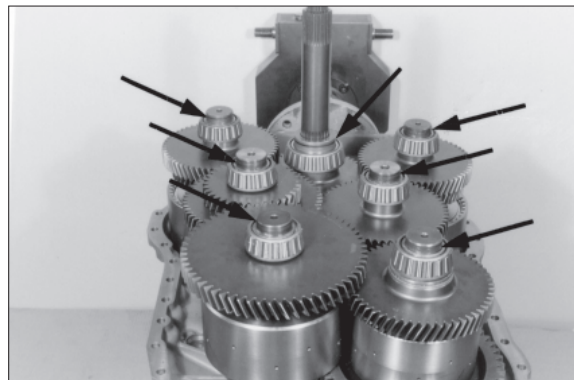

73073TM198

- ⑩ Tilt housing cover 180°.
Mount eye bolts, see Arrows.
- ※ Special tool
Eye bolt M20 (2EA) 0636 804 003
Eye bolt M16 (1EA) 0636 804 001
Puller device 5870 000 017

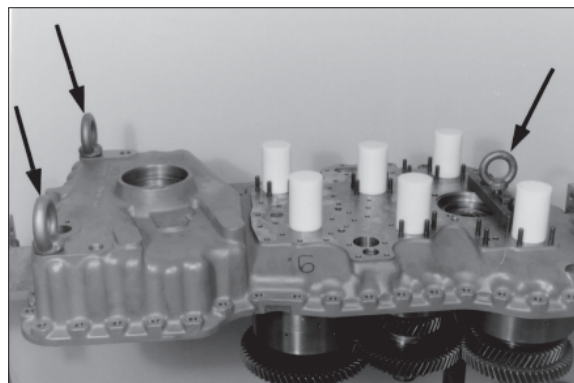

73073TM199

- ⑪ Install adjusting screws.
Position housing cover by means of lifting device carefully on the gearbox housing until contact is obtained, respectively position the clutches in the gearbox housing.
- ※ Pay attention to the overlapping of the oil pipes with the bores in the housing cover.
- ※ Special tool
Lifting chain 5870 281 047
Adjusting screws 5870 204 007

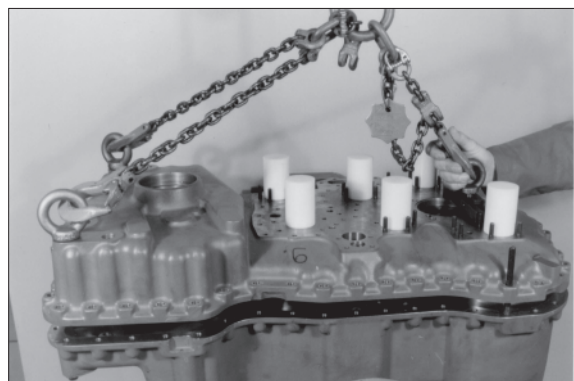

73073TM200

⑫ Remove handles again.

- ※ Special tool
- Lifting chain

5870 281 047

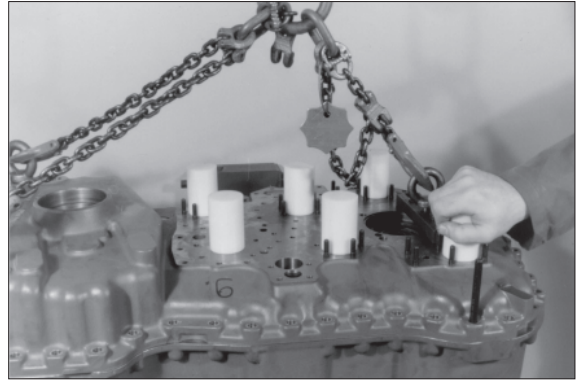

73073TM201

⑬ Separate housing cover from gearbox housing, using lifting device.

- ※ Special tool
- Lifting chain

5870 281 047

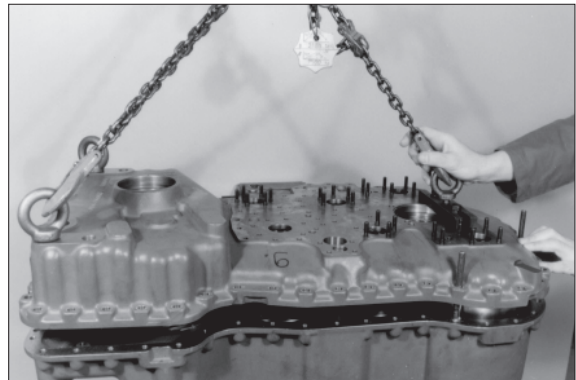

73073TM202

(6) Output

① Assemble sheet and press both bearing inner races against shoulder until contact is obtained.

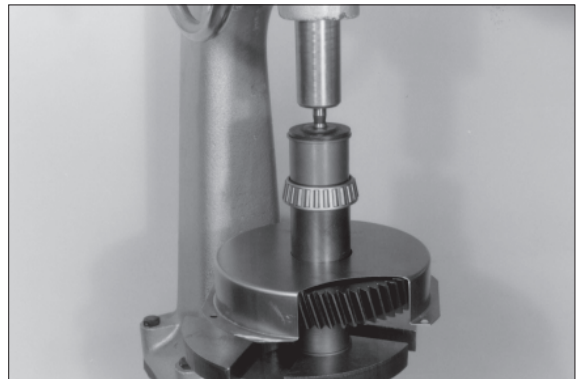

73073TM203

② Insert bearing outer race (Arrow) into the housing bore until contact is obtained.

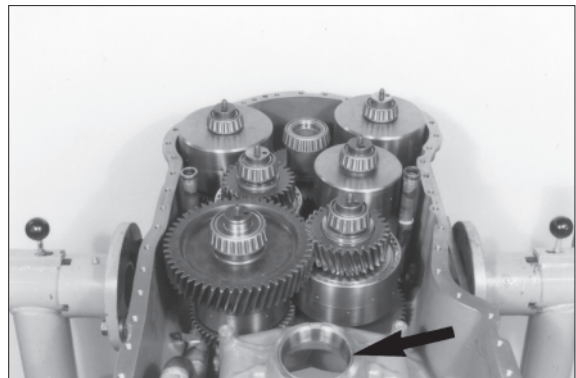

73073TM204

- ③ Position screening plate.

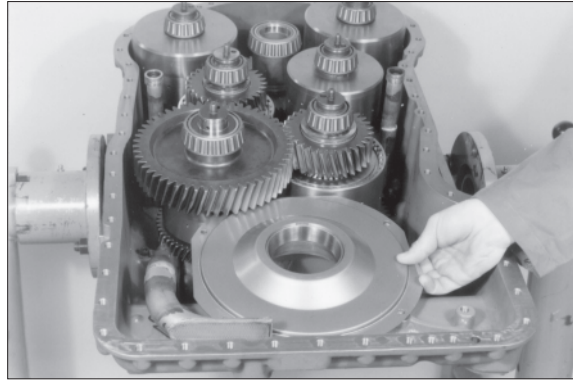

73073TM205

- ④ Insert output shaft.

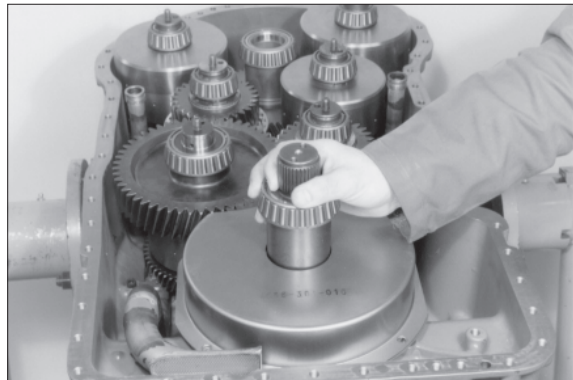

73073TM206

- ⑤ Fasten both sheets by means of socket head screws (4EA).

- ※ Insert socket head screws with loctite.
· Torque limit : 2.35 kgf · m (17.0 lbf · ft)

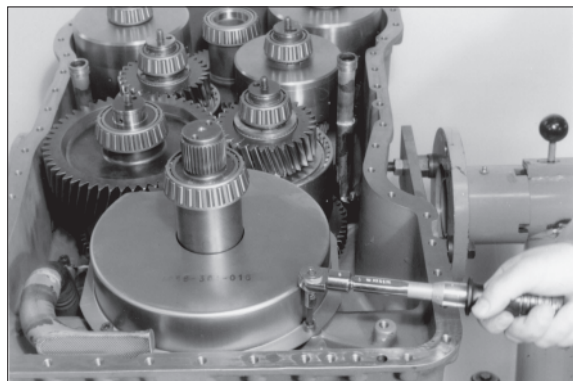

73073TM207

- ⑥ Squeeze rectangular rings (6EA) into the recesses of the clutch shafts and hook them in.

Now, grease rectangular rings and align them centrally.

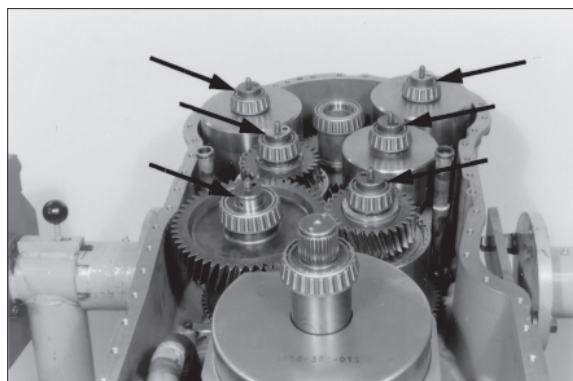

73073TM208

- ⑦ Insert both O-rings (arrows) into the annular groove of the oil pipes and grease them.

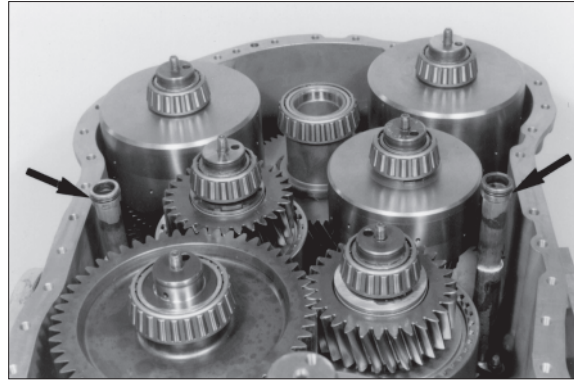

73073TM209

- ⑧ Cover mounting face with sealing compound loctite.
Install adjusting screws (S) and position housing cover carefully against gearbox housing until contact is obtained, using lifting device.

※ Pay attention to the overlapping of the oil pipe with the bores in the housing cover.

※ Special tool

Adjusting screws 5870 204 007

Lifting chain 5870 281 047

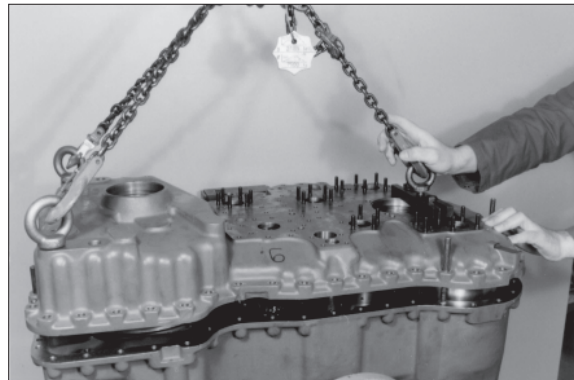

73073TM210

- ⑨ Install both cylindrical pins.

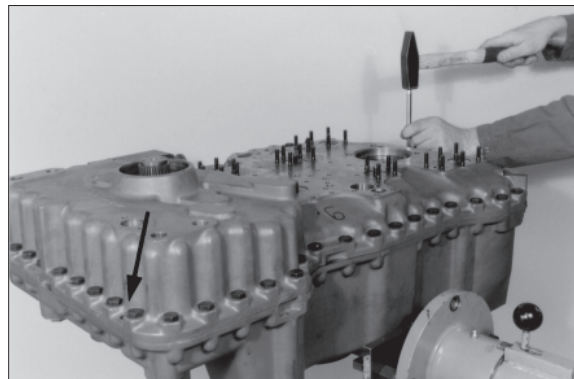

73073TM211

- ⑩ Fasten housing cover by means of hexagon head screws.

· Torque limit : 4.69 kgf · m (33.9 lbf · ft)

※ Pay attention to the position of the fixing plate, see arrow.

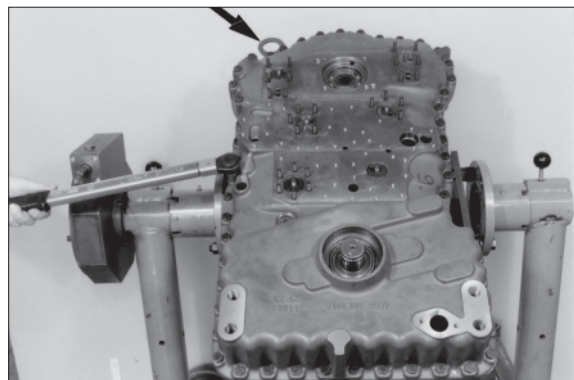

73073TM212

⑪ Install shaft seal, with the sealing lip facing the oil chamber.

※ By application of the prescribed driver, the exact installation position is obtained. Wet rubber-coated outer diameter with spirit.

Grease sealing lip.

※ Special tool

Driver 5870 048 057

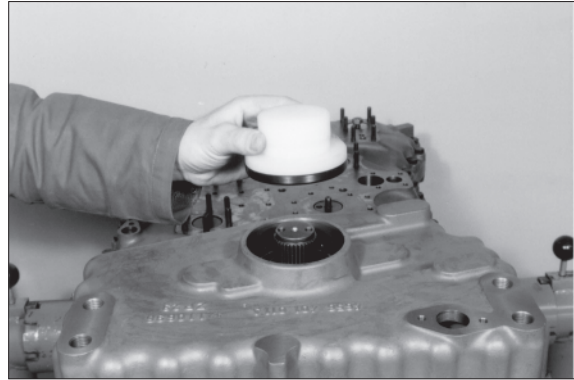

73073TM213

⑫ Heat the output flange (maximum 90°C), assemble it and fix it by means of washer and hexagon head screws.

※ Wet contact area of washer with sealing compound loctite.

· Torque limit : 3.47 kgf · m (25.1 lbf · ft)

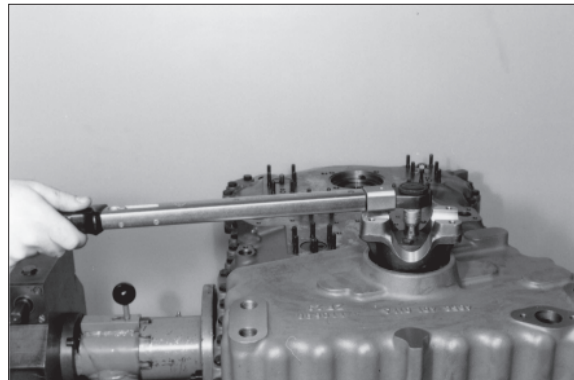

73073TM214

⑬ Fix hexagon head screws by means of lock plate.

Install output flange on the converter side accordingly (figure ⑪~⑬).

※ Special tool

Driver 5870 057 011

Handle 5870 260 002

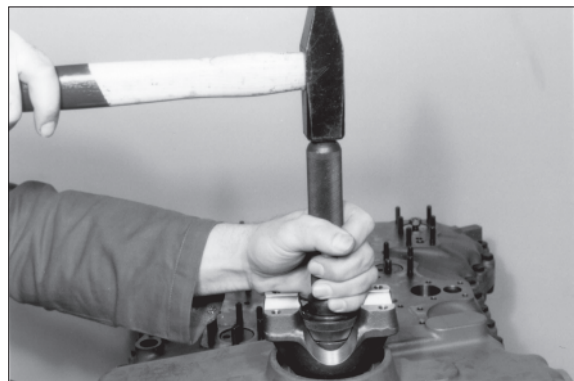

73073TM215

(7) Converter pressure valve

① The illustration on the right shows the components of the converter pressure valve.

- 1 Piston
- 2 Compression spring
- 3 Valve insert
- 4 Roll pin

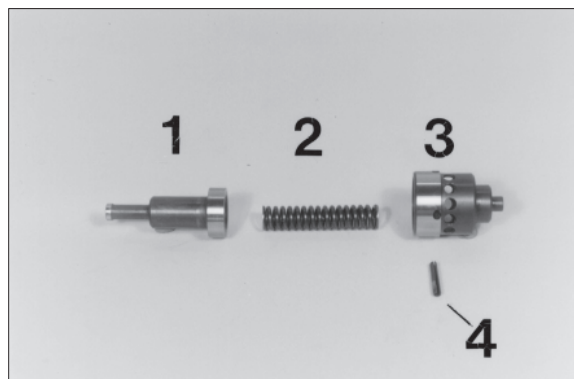

73073TM220

- ② Introduce compression spring and piston, preload and fix them by means of roll pin.

※ Special tool
Assembly aid

5870 345 084

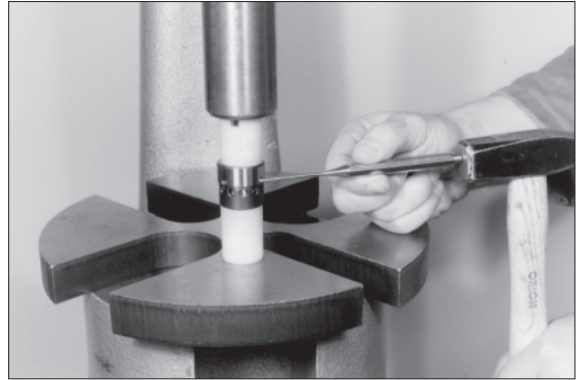

73073TM221

- ③ Insert pre-assembled converter pressure valve into the housing bore.

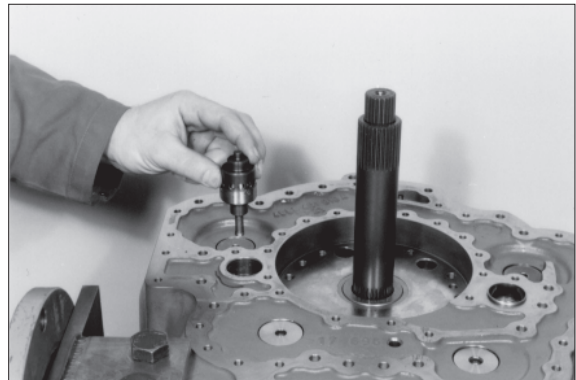

73073TM222

- (8) Oil feed housing-Transmission pump

- ① Install two adjusting screws (arrows) and mount flat gasket.

※ Special tool
Adjusting screws

5870 204 011

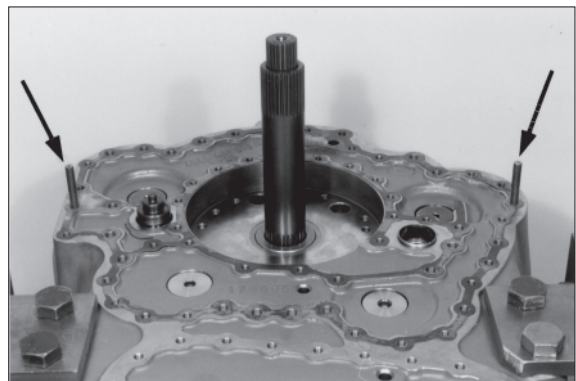

73073TM223

- ② Mount oil feed housing and fix it provisionally by means of washers and hexagon head screws.

※ Screw the hexagon head screws in only until contact is obtained-do not tighten.

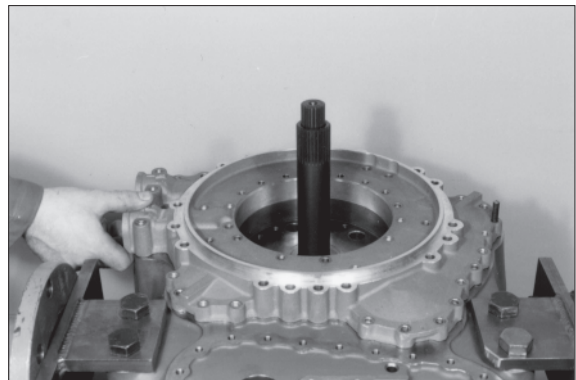

73073TM224

③ Install two adjusting screws and introduce stator shaft until contact is obtained.

※ Pay attention to the overlapping of the bores.

※ Special tool

Adjusting screws 5870 204 007

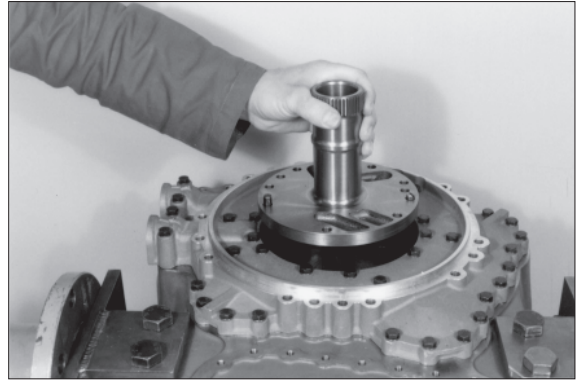

73073TM225

④ Install O-ring (arrow) and oil it.

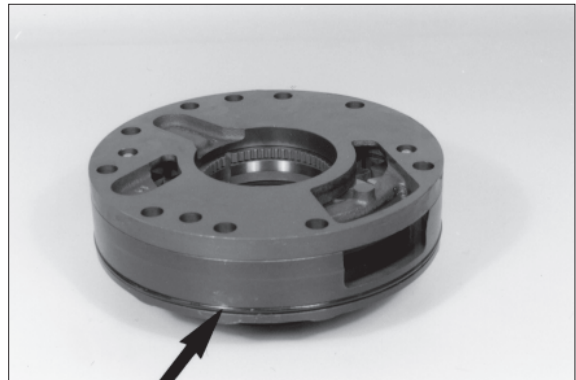

73073TM226

⑤ Introduce transmission pump until contact is obtained.

※ Pay attention to the overlapping of the bores.

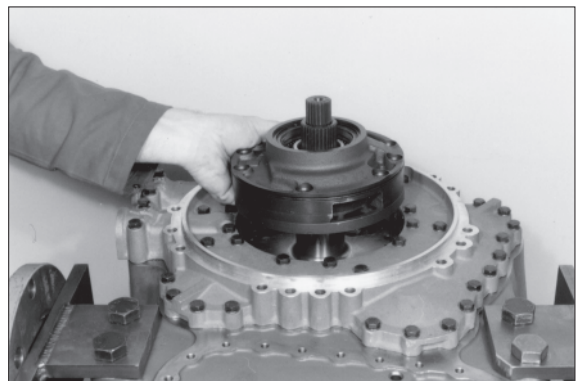

73073TM227

⑥ Equip socket head screws with new O-rings (arrow).

※ Grease O-rings.

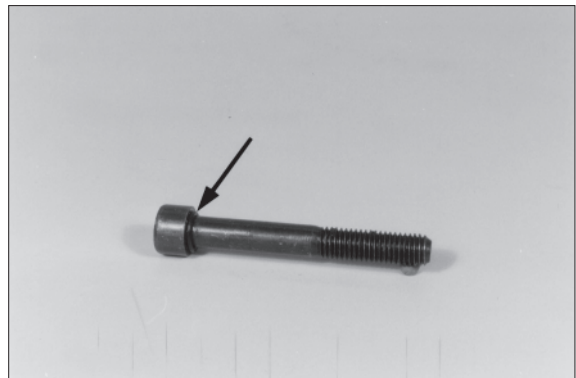

73073TM228

- ⑦ Fasten transmission pump by means of socket head screws.
· Torque limit : 4.69 kgf · m (33.9 lbf · ft)

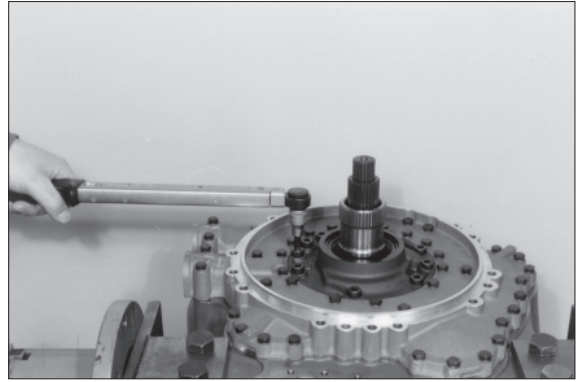

73073TM229

- ⑧ Fix oil feed housing finally by means of hexagon head screws (mount flat washers).
· Torque limit : 2.55 kgf · m (18.4 lbf · ft)
※ Pay attention to the installation position of the fixing plate (arrow), see the next figure.

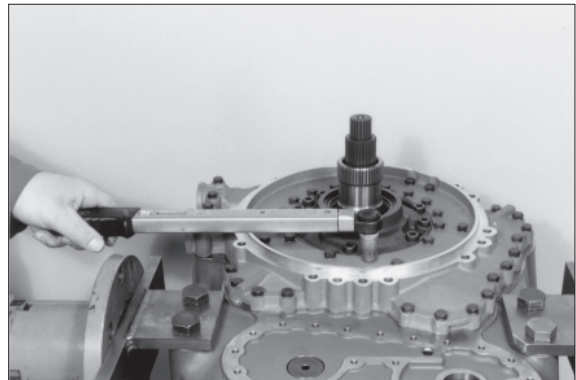

73073TM230

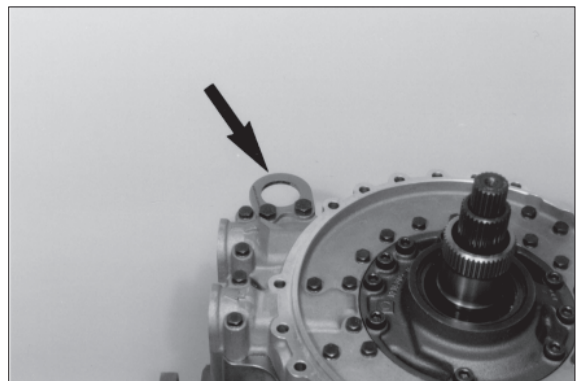

73073TM231

- ⑨ Fit flat gasket and fasten cover by means of hexagon head screws.
· Torque limit : 2.35 kgf · m (17.0 lbf · ft)

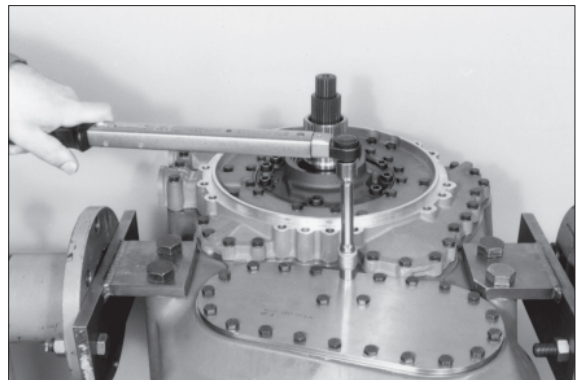

73073TM232

(9) Engine connection-Converter

- ① Fasten converter housing by means of hexagon head screws.
· Torque limit : 6.93 kgf · m (50.2 lbf · ft)

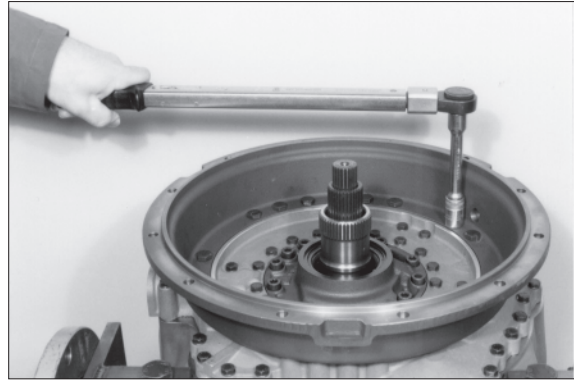

73073TM233

- ② Fasten input shaft, membrane and disk by means of hexagon head screws.
· Torque limit : 11.7 kgf · m (84.8 lbf · ft)

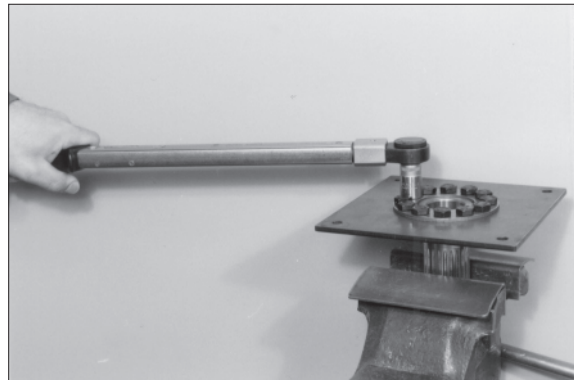

73073TM234

- ③ Fasten membrane on the converter, using hexagon head screws(Mount flat washers).
· Torque limit : 11.7 kgf · m (84.8 lbf · ft)
※ Insert hexagon head screws with loctite.

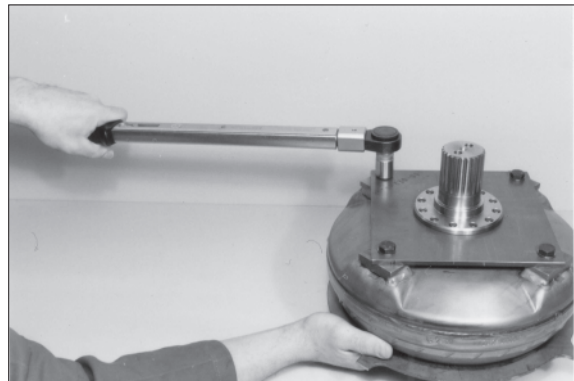

73073TM235

- ④ Introduce converter until contact is obtained.
※ Impulse disk of the converter must be centrally to the bore of the inductive transmitter, see on the below figure.
Only in this way it is ensured that the converter has been completely introduced.



73073TM236

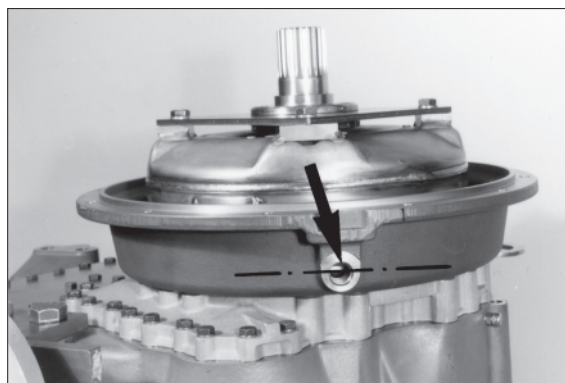

73073TM237

- ⑤ Insert ball bearing until contact is obtained and fix it by means of circlip.

※ Special tool

Set of internal pliers 5870 900 013



73073TM238

- ⑥ Assemble housing cover.

Install input flange, fit disk and pull cover by means of hexagon head screws evenly against shoulder.

※ Pay attention to the radial installation position of the cover.

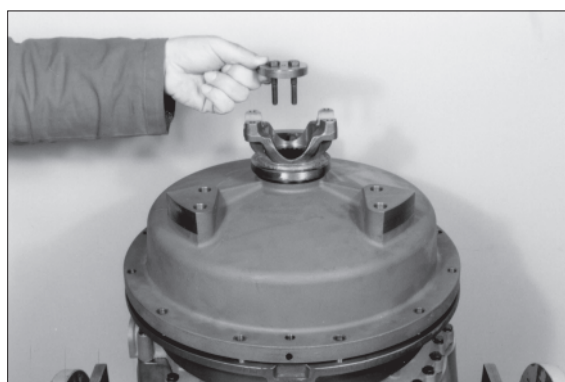

73073TM239

- ⑦ Fasten cover by means of hexagon head screws and nuts on the converter housing.

• Torque limit : 4.69 kgf · m (33.9 lbf · ft)

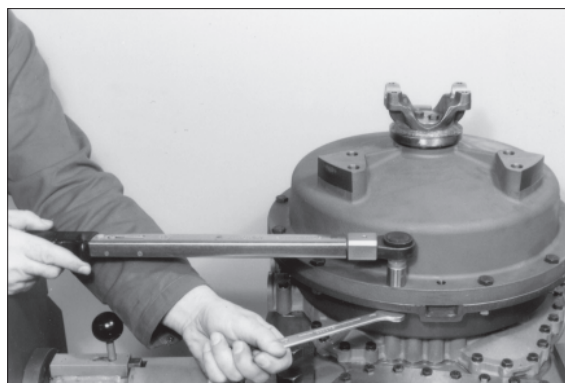

73073TM240

- ⑧ Fasten input flange finally and fix hexagon head screws by means of lock plate.

· Torque limit : 3.47 kgf · m (25.1 lbf · ft)

※ Special tool

Driver 5870 057 010

Handle 5870 260 002



73073TM241

(10) Converter safety valve

- ① The illustration on the right shows the components of the converter safety valve.

- 1 Plate
- 2 Ball
- 3 Compression spring
- 4 Valve insert
- 5 Valve sleeve
- 6 Cylindrical pin

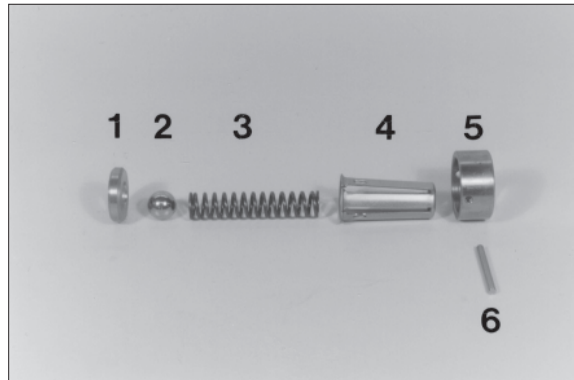

73073TM245

- ② Assemble components according to figure ①, preload and fix by means of cylindrical pin.

※ Special tool

Assembly aid 5870 345 084

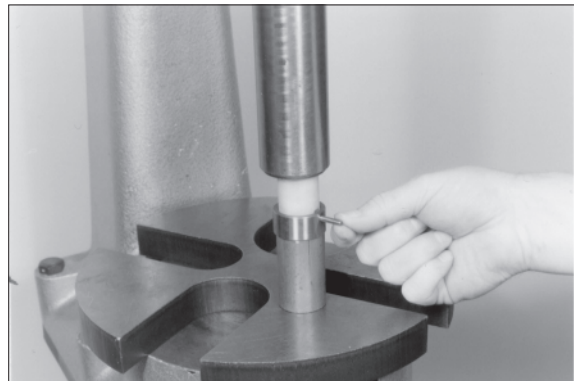

73073TM246

- ③ Insert converter safety valve into the housing bore until contact is obtained.

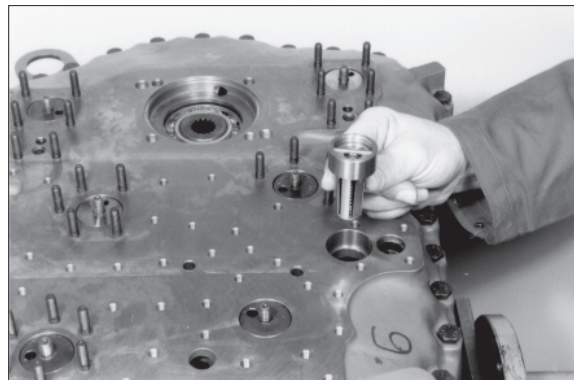

73073TM247

(11) Fit duct plate

- ① Install both screw plugs (arrows),
- ※ Install new sealing rings.

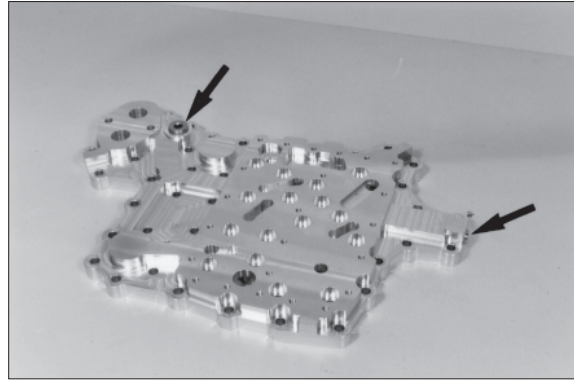

73073TM248

- ② Install gasket, place duct plate against shoulder and fasten it by means of socket head screws and hexagon nuts (mount flat washers).

• Torque limit : 2.55 kgf · m (18.4 lbf · ft)

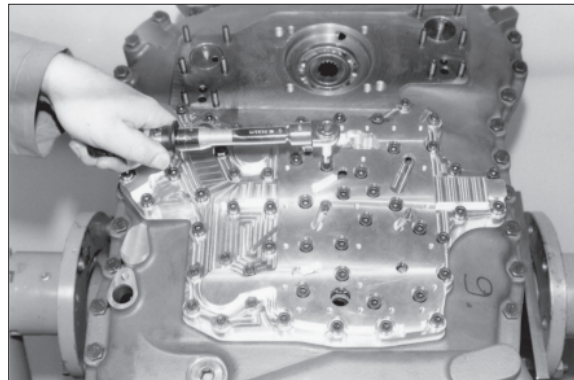

73073TM249

(12) Fit hydraulic control unit

- ① Install two adjusting screws.
Mount gasket 1, intermediate plate 2 and gasket 3.
- ※ Pay attention to the installation position of the different gaskets, see also the following draft.
- ※ Special tool
Adjusting screws 5870 204 031

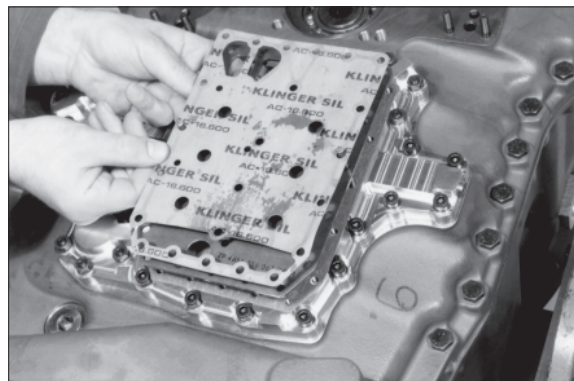

73073TM250

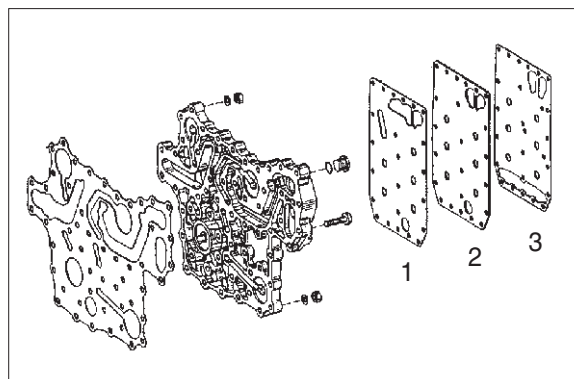

3-135(4) (740-7)

- ② Fasten complete control unit on the duct plate, using socket head screws.
· Torque limit : 0.97 kgf · m (7.01 lbf · ft)

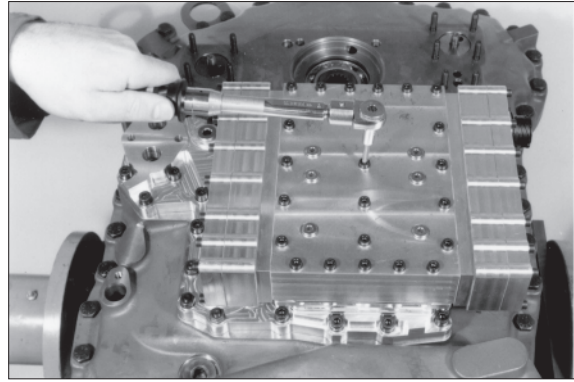

73073TM251

(13) Filter

- ① The illustration on the right shows the components of the filter unit.
※ Install new O-rings (arrows)

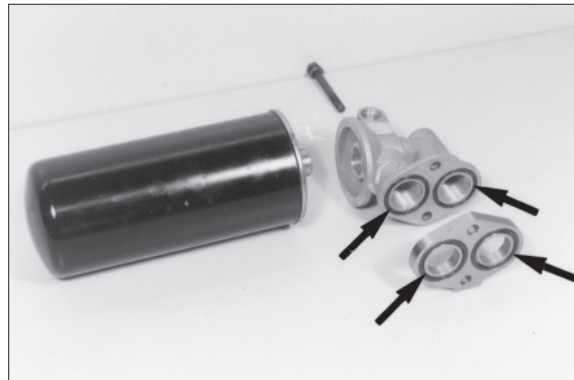

73073TM252

- ② Fasten intermediate plate and filter head by means of hexagon head screws (mount flat washers).
· Torque limit : 2.55 kgf · m (18.4 lbf · ft)

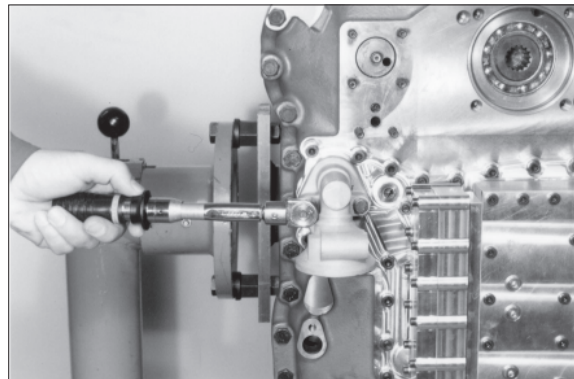

73073TM253

- ③ Oil gasket and tighten exchange filter hand-tight.

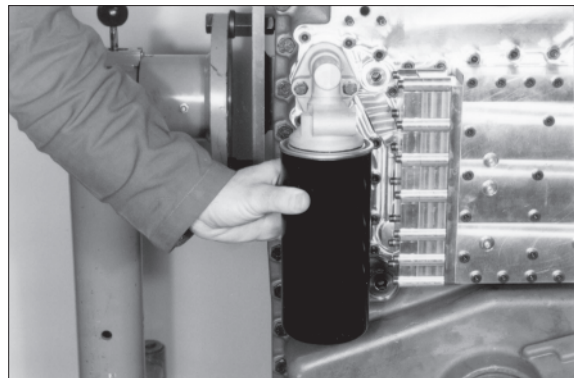

73073TM254

- ④ If necessary, install warning switch (according to the version).

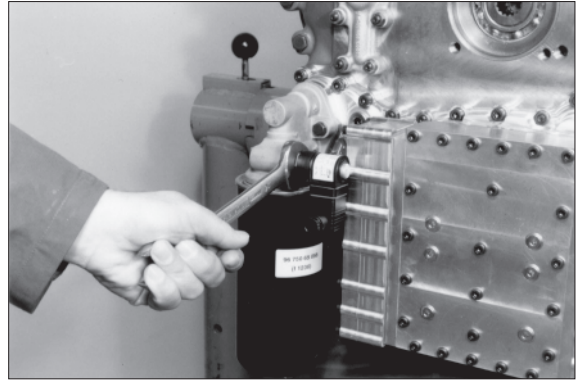

73073TM255

- ⑤ Insert O-ring (arrow) into the annular groove of the oil feed covers.



73073TM256

- ⑥ Fasten the two covers (arrows) by means of hexagon nuts (mount flat washers) on the housing.
• Torque limit : 2.55 kgf · m (18.4 lbf · ft)

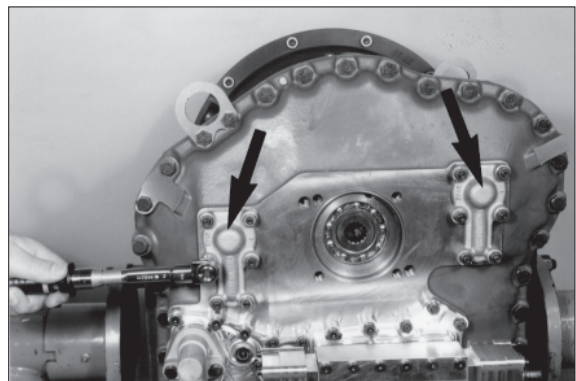

73073TM257

- ⑦ Mount oil level tube.
Install screw plug (arrow).
※ Install new gaskets.
• Torque limit : 2.35 kgf · m (17.0 lbf · ft)
• Torque limit (screw plug M26 × 1.5) :
8.16 kgf · m (59.0 lbf · ft)

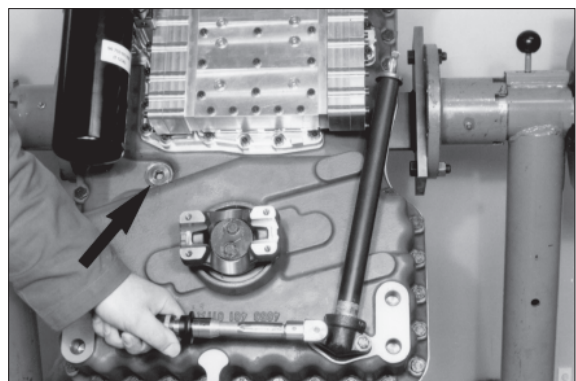

73073TM258

(14) Speed sensor and inductive transmitter

- ① Grease O-ring, introduce speed sensor (arrow) and fasten it by means of socket head screw.

· Torque limit : 2.35 kgf · m (17.0 lbf · ft)

34 Speed-output and -speedometer

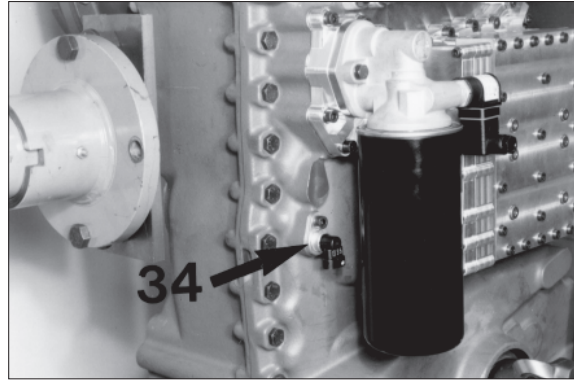

73073TM259

- ② Equip the inductive transmitters with new O-rings and install them.

· Torque limit : 3.06 kgf · m (22.1 lbf · ft)

48 Speed-engine

47 Speed-central gear train

21 Speed-turbine

Install breather (Arrow).

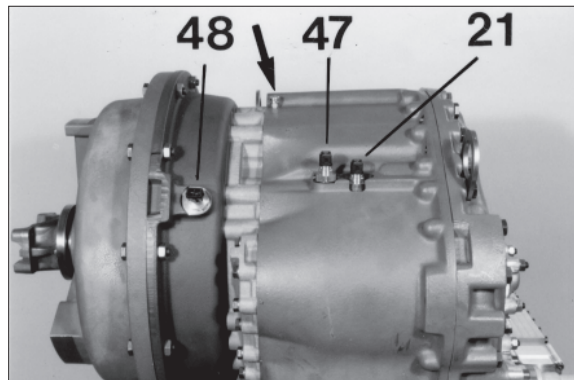

73073TM260

- ③ Install gasket and cover plate, arrow 1.

· Torque limit : 2.35 kgf · m (17.0 lbf · ft)

Equip screw plug (arrow 2) with new O-ring and install it.

· Torque limit : 14.3 kgf · m (103.3 lbf · ft)

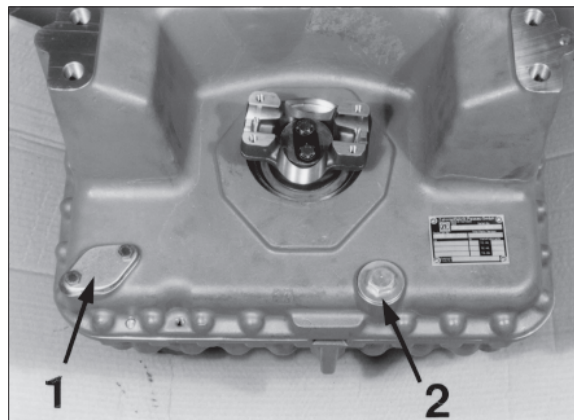

73073TM261

3. FRONT AXLE

1) HOW TO DISASSEMBLY THE PLANETARY REDUCTION AND AXLE SHAFT

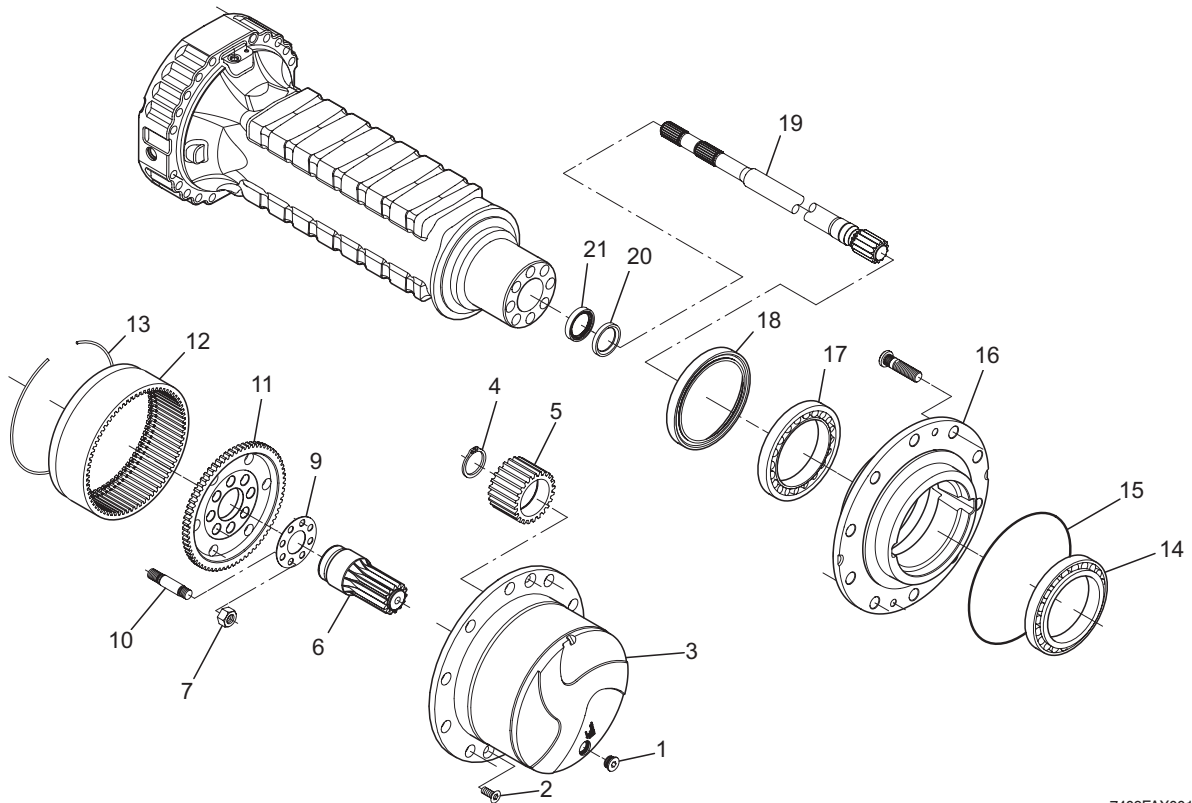

7409FAX001

(1) Remove oil-level plug (1) and drain oil.

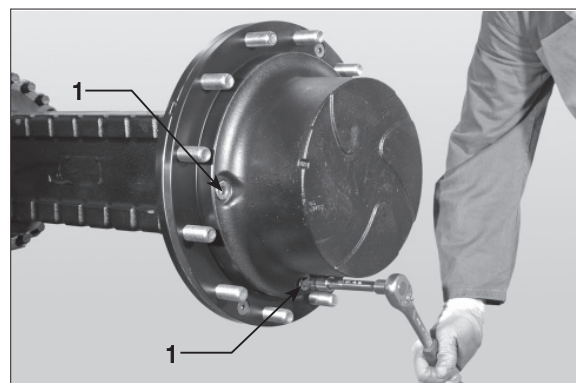

7409FAX002

(2) Remove the locking screws (2) of planetary cover (3).

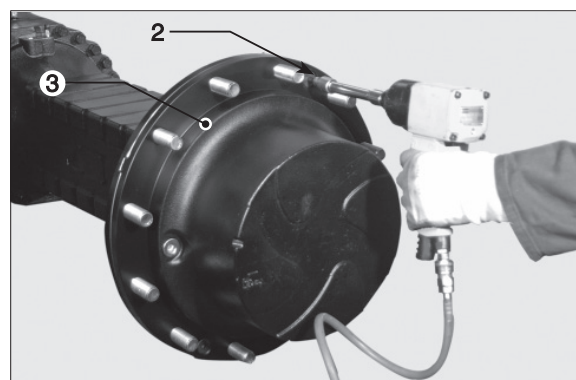

7409FAX003

- (3) Using two screwdrivers or two levers inserted in the slots provided, disjoin the planetary cover (3) away from the wheel hub (16).



7409FAX004

- (4) Remove the cover (3).

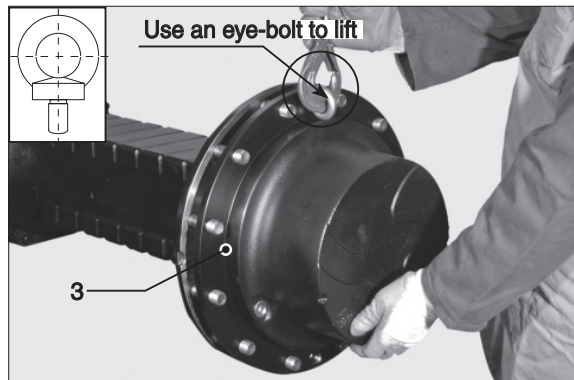

7409FAX005

- (5) Remove the sun gear (6).

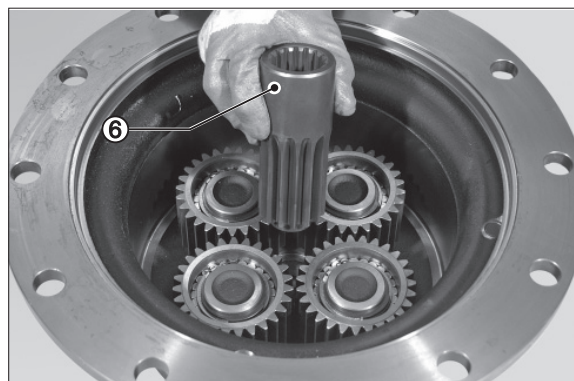

7409FAX006

- (6) Remove the safety spring rings (4) of the planetary gears (5).

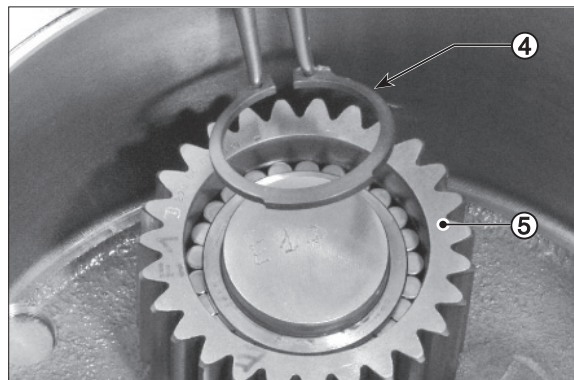

7409FAX007

(7) Remove the planetary gears (5).

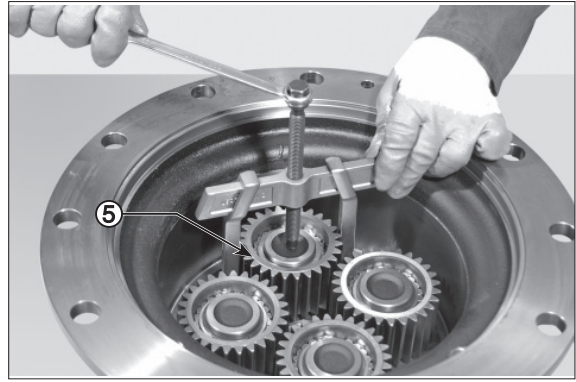

7409FAX008

(8) Insert air pressure to maintain in correct position the brake discs.

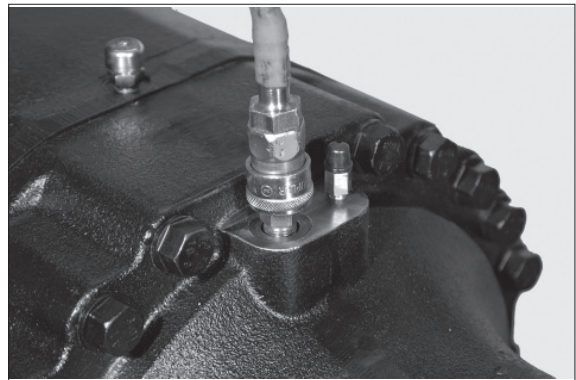

7409FAX009

(9) Remove the axle shaft (19).

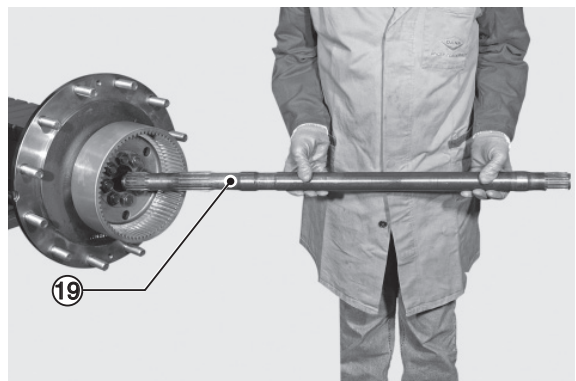

7409FAX010

(10) Using an extractor, remove seal ring (21) and guide ring (20).

※ Note down the direction of assembly of snap ring.

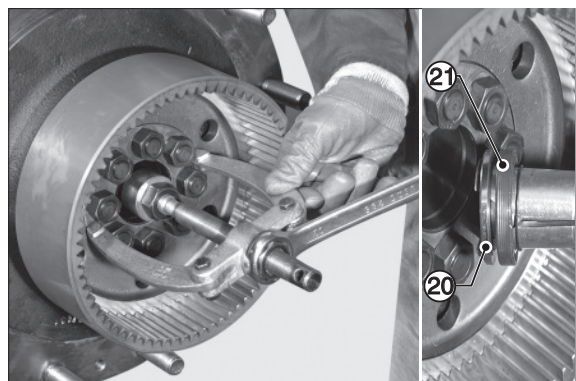

7409FAX011

(11) Loosen the nuts (7) and remove them.

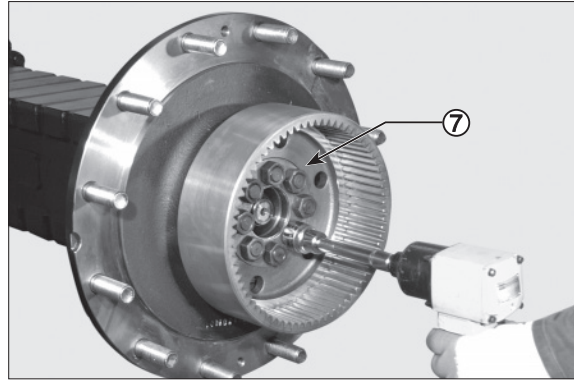

7409FAX012

(12) Remove the safety flange (9).

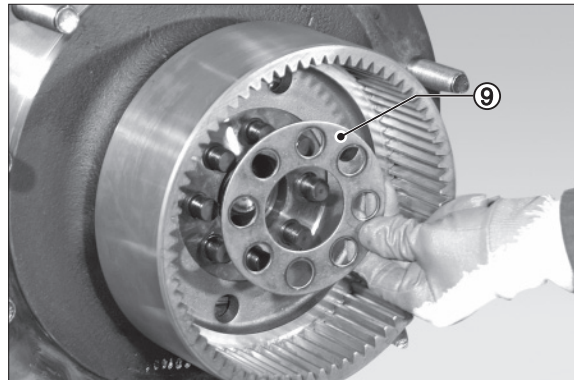

7409FAX013

(13) Using two screwdrivers or two levers inserted in the slots provided, disengage the crown wheel (11) from the hub (16). Remove the crown (11).

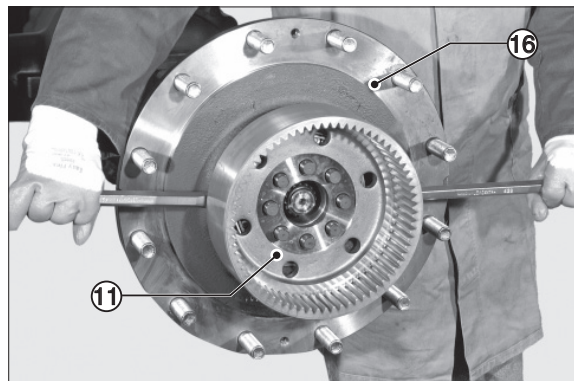

7409FAX014

(14) Remove the snap ring (13) from the crown (12).

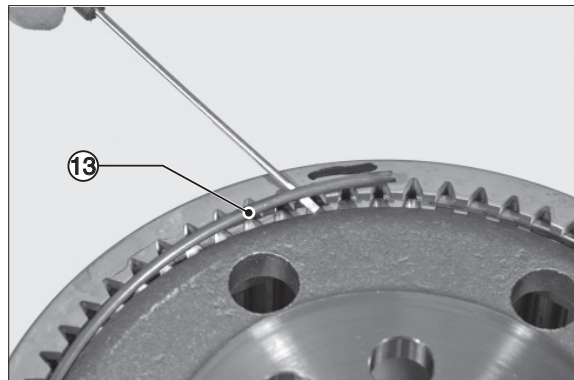

7409FAX015

(15) Remove the crown flange (11).

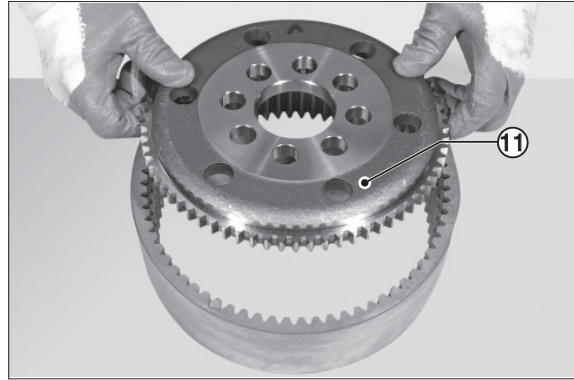

7409FAX016

(16) With the help of a hammer, shift the hub (16) and the external bearing (13).

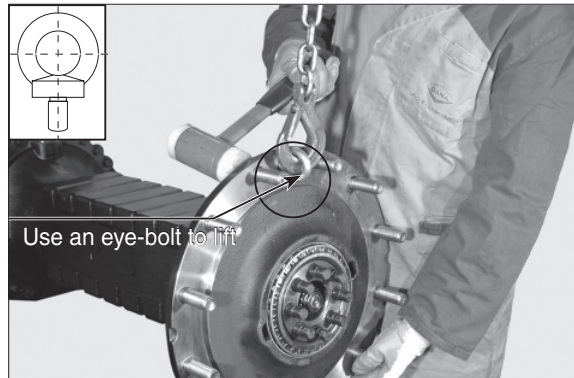

7409FAX017

(17) Remove the seal ring (18) from the hub (16).

- ※ Note down direction of assembly.
- ※ The seal ring may not be reused.

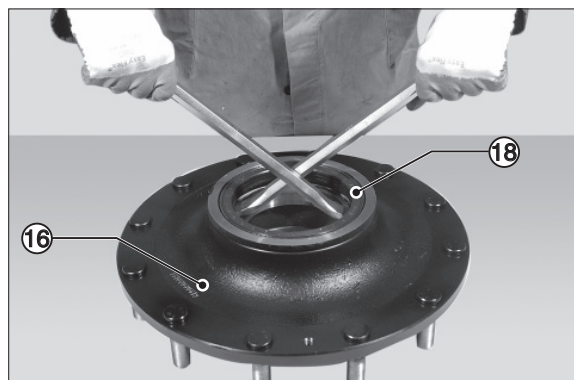

7409FAX018

(18) Remove the internal bearing (8).

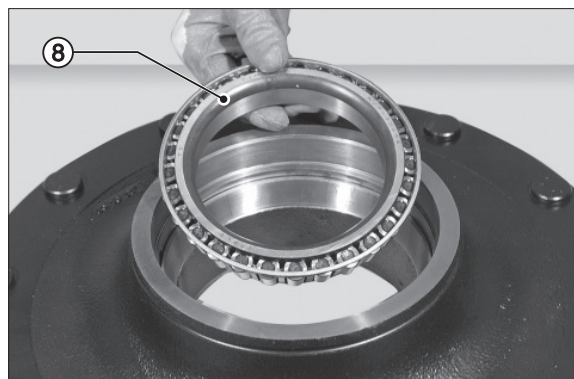

7409FAX019

(19) Remove the external thrust blocks of bearings (14) and (17), using a pin driver.

※ Hammer in an alternate sequence to prevent crawling and deformation of the thrust blocks.

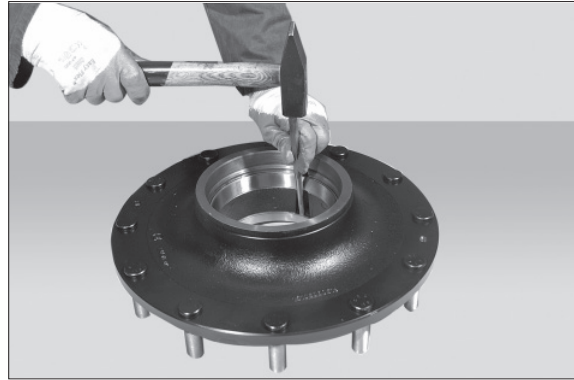

7409FAX020

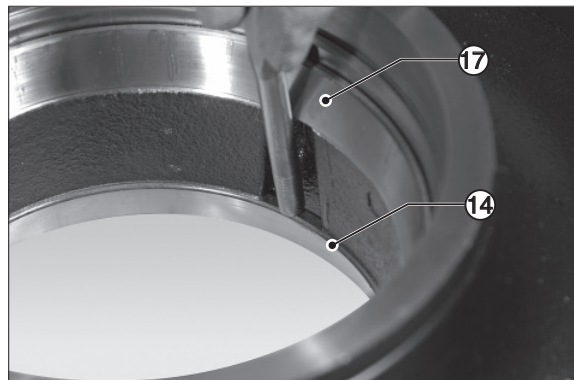

7409FAX021

2) ASSEMBLING THE PLANETARY REDUCTION AND AXLE SHAFT

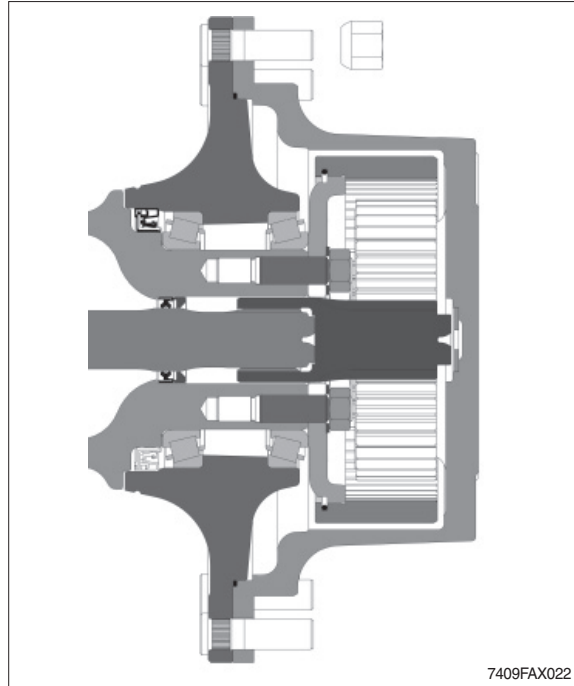

- (1) Position the wheel hub (16) under a press; lubricate the seat of the bearing cones (14)(17) and, using tool T1, install the bearing cup of the bearing cone (14)(17).

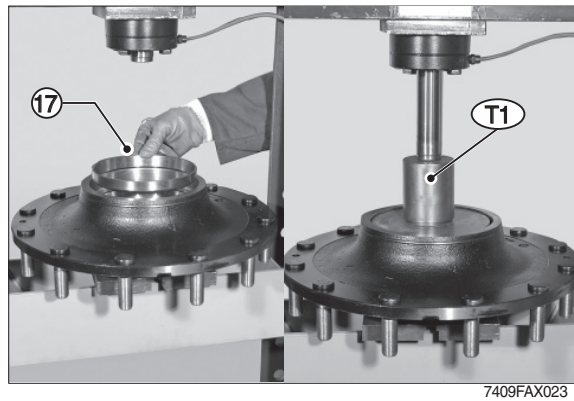

- (2) Fit the bearing (17) and seal ring (18) into the internal thrust block.

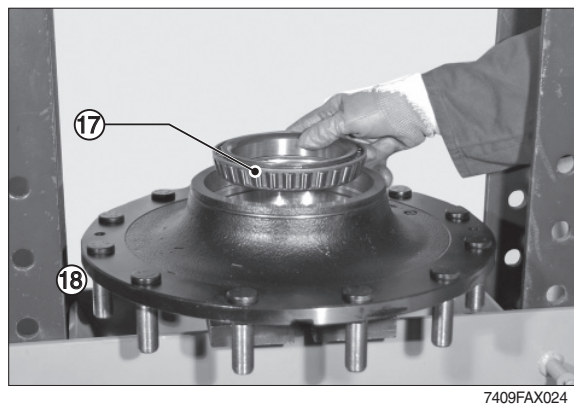

- (3) Using special tool apply a jointing compound for seals to the outer surface of the sealing ring (18).
Position the sealing ring (18) in the hub (16).

※ Check that the ring (18) is correctly oriented.

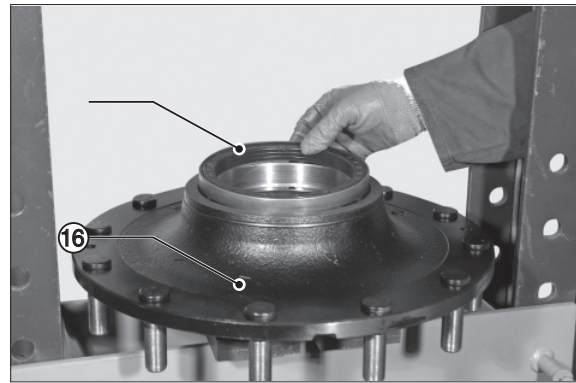

- (4) Position tool T2 and press the sealing ring (19) into its seat.

※ Install the seal ring, taking care to maintain the predefined distance of $7.00 \text{ mm} \pm 0.5$.
Check the flatness of seal ring.

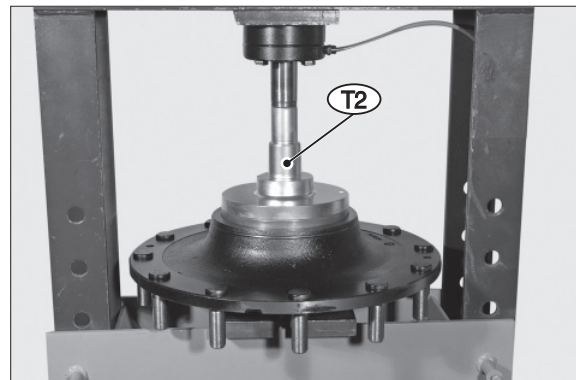

- (5) Install the wheel hub (16).

※ Move the bearing cone to the limit stop by hammering lightly all around the edge.

If insertion is difficult, use a punch with a suitable diameter to drive it seat.

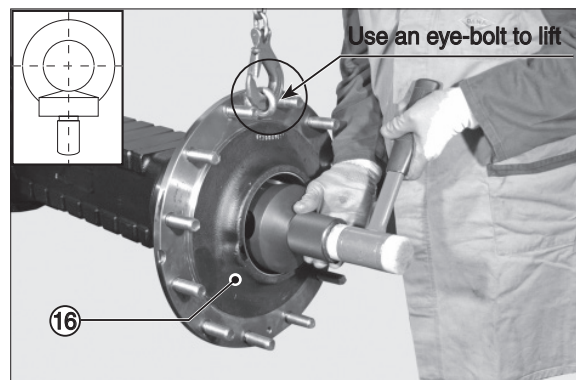

- (6) Install the external bearing cone (14).

※ Using a plastic hammer, drive the bearing cone to the limit stop by lightly hammering around the edge.

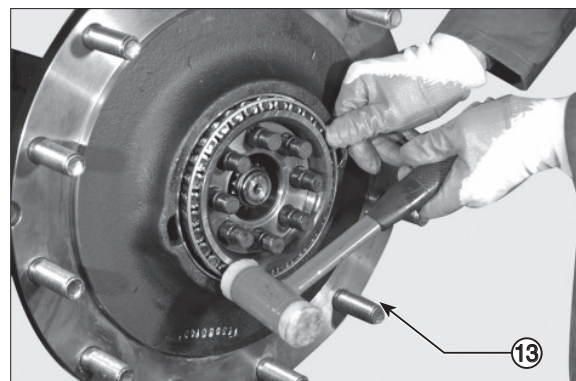

- (7) Install the crown wheel flange (11).
Insert the snap ring (13) in order to fix the flange (11) in the crown (13).

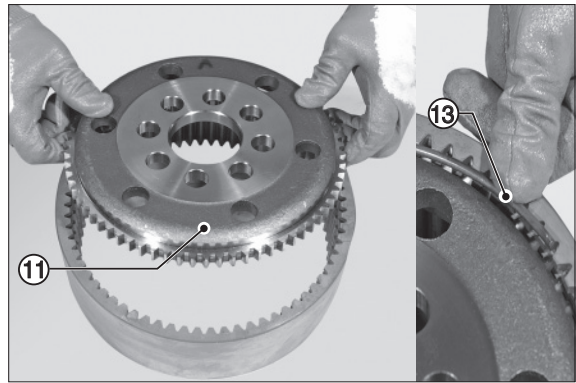

7409FAX029

- (8) Fit the complete crown flange (11).

- ※ In order to fasten the flange (11), use a plastic hammer and alternately hammer on several equidistant points.



7409FAX030

- (9) Install the security flange (9).

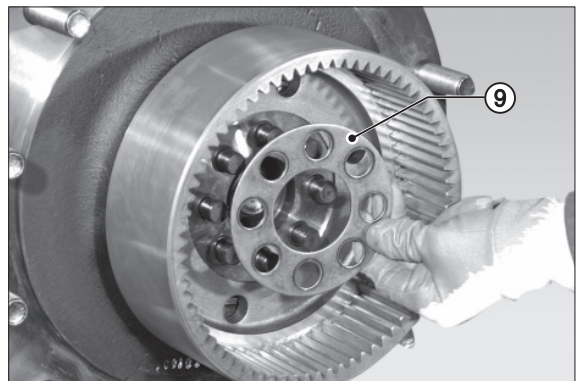

7409FAX031

- (10) Coat the nuts (7) with loctite 242 and screw them.

Tighten nuts (7) in two stages, using the criss-cross method.

- Initial torque wrench setting :
33.7 kgf · m (243 lbf · ft)
- Final torque wrench setting :
39.3 kgf · m (284 lbf · ft)

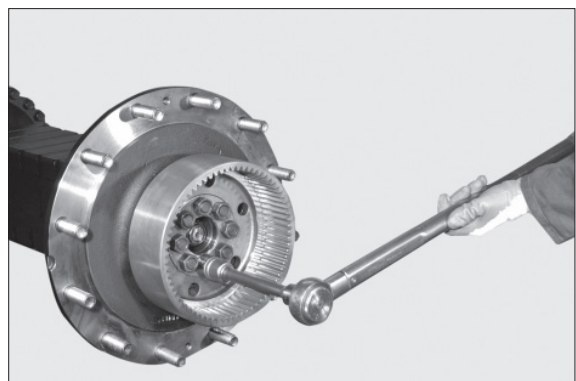

7409FAX032

(11) Lubricate and fit the seal ring (21) and guide ring (20) onto tool T3 ; install the rings into the arm.

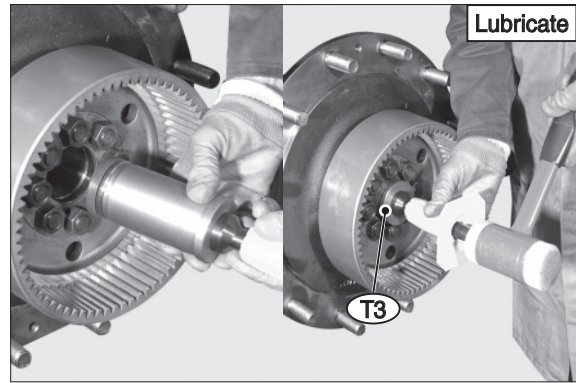

※ Pay particular attention to the direction of assembly of the rings.

(12) Grease sealing face of axle shaft (19).
Install the axle shaft (19) making sure it is properly engaged in the braking disks and in the differential unit.

※ Be very careful not to damage the seal ring (21).

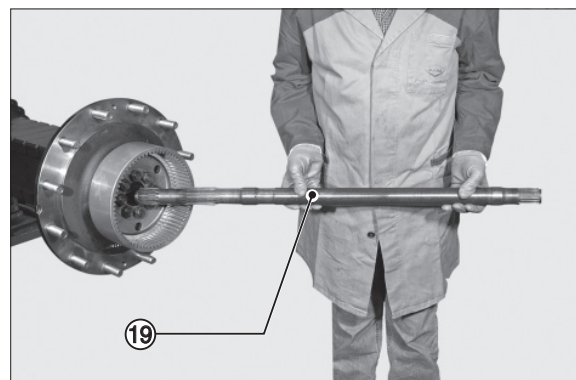

(13) Substitute the O-ring (15).
Lubricate the O-ring before fitting.

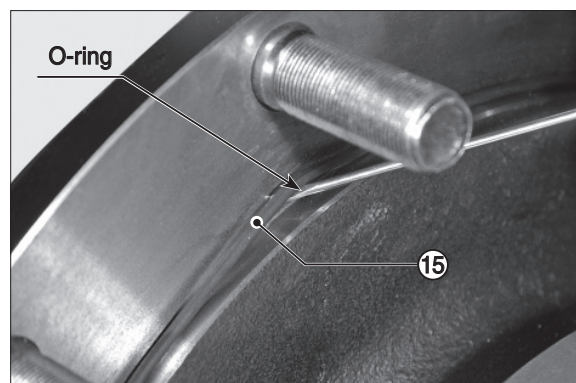

(14) Accurately check the orientation.

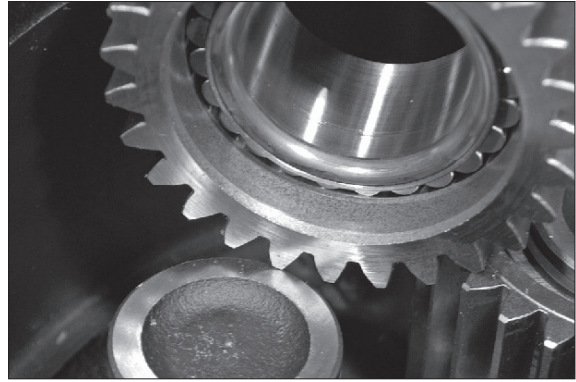

7409FAX036

(15) Insert the planet wheel gears (5) into the cover (3).
Lock gears (5) into position by installing the snap rings.

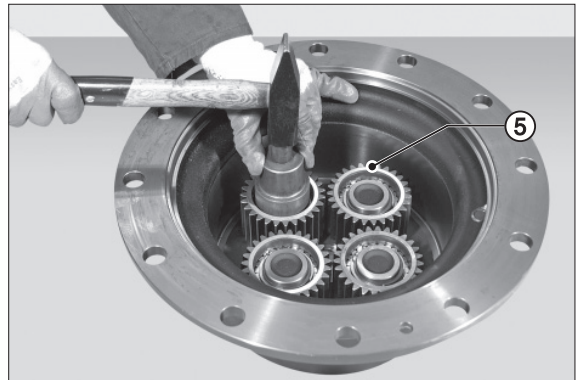

7409FAX037

(16) Fit the planetary carrier cover (3) onto the hub (16).

※ Check that the O-ring is in good condition and in position.

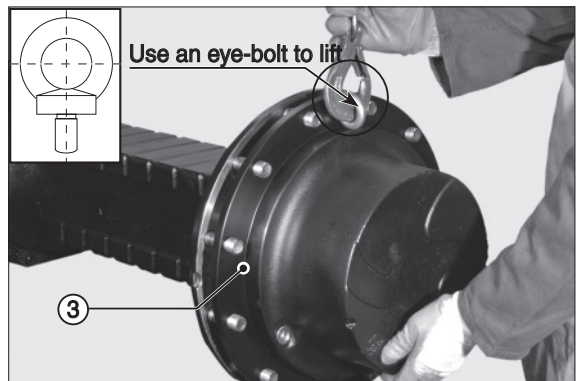

7409FAX038

(17) Lock the planetary carrier cover (3) by tightening the screws (2).

• Torque wrench setting for screws :
18.6~20.6 kgf · m (135~149 lbf · ft)

Install the oil-level plug (1).

• Torque wrench setting for screws :
9.18 kgf · m (66.4 lbf · ft)

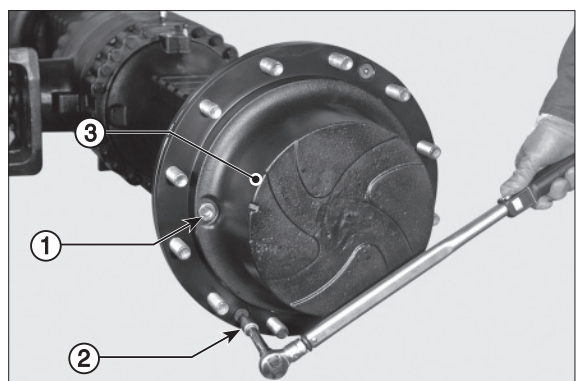

7409FAX039

3) DISASSEMBLY SERVICE BRAKE

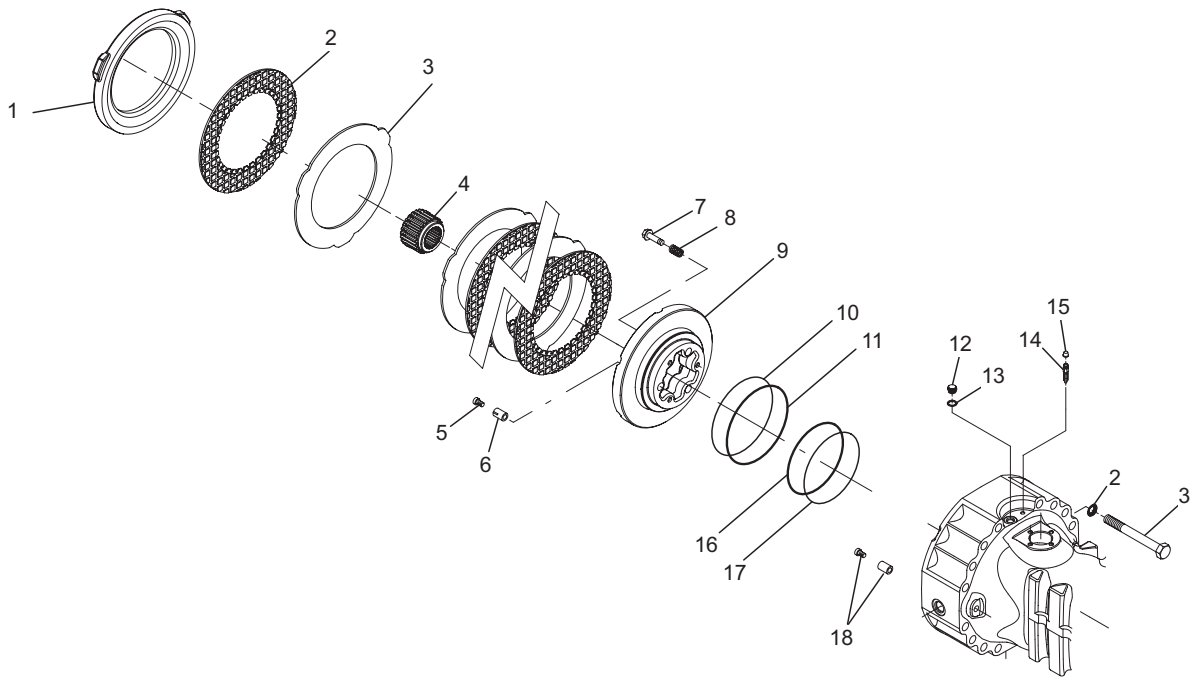

7409FAX040

- (1) If axle is positioned on an overhaul bench, place a safety anti-tilting stand "B" under the arm that remains connected and block wheels, if any.

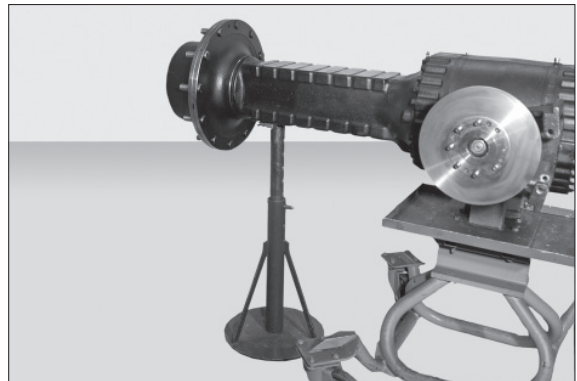

7409FAX041

- (2) Sling the arm to be removed and connect it to a hoist. Remove the retainer screws (3) and relative washers (2).

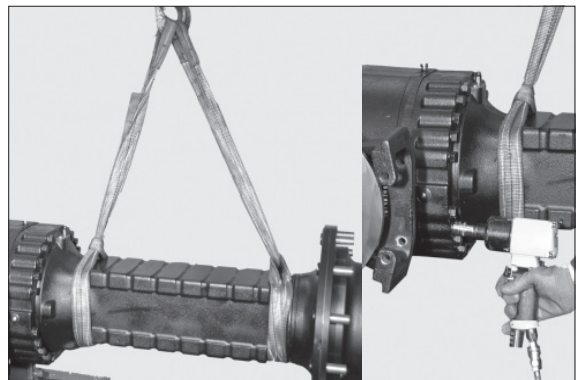

7409FAX042

- (3) Note down their order of assembly and remove the counterwasher (1).

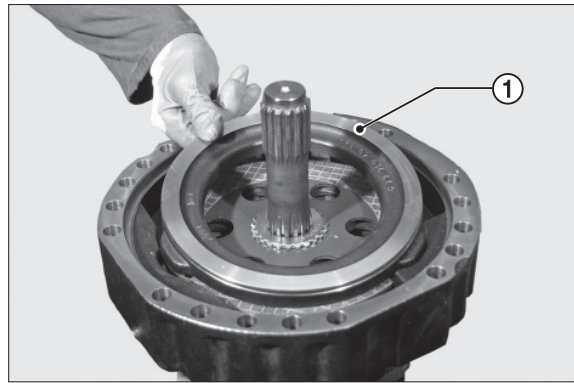

7409FAX043

- (4) Remove braking discs (2)(3), noting down direction of assembly.

※ If disks are not to be replaced, avoid changing their position.

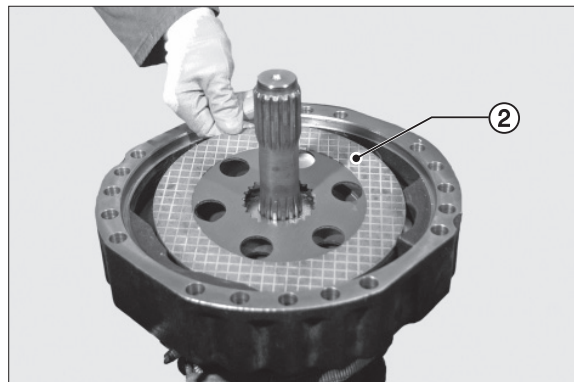

7409FAX044

- (5) Remove the flange (4) complete with the discs.
Noting down direction of assembly.

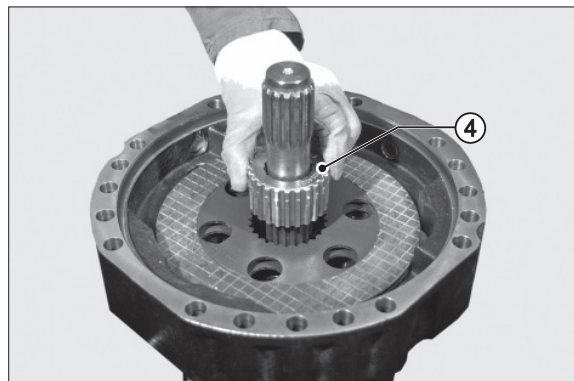

7409FAX045

- (6) Remove the axle shaft.

※ Be very careful not to damage the seal ring.



7409FAX046

(7) Remove the reversal springs (8) and screws (7).

※ If the springs (8) are weak or deformed they must be replaced.

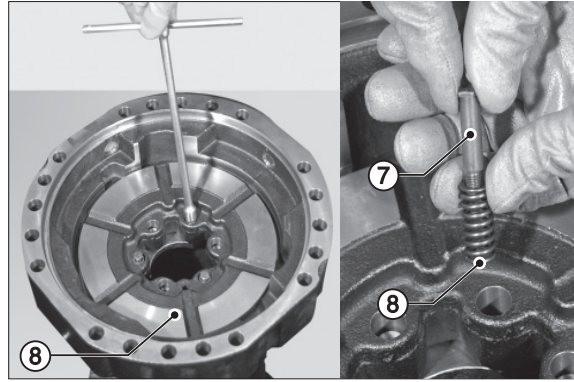

7409FAX047

(8) Remove the adjusting screws (5).

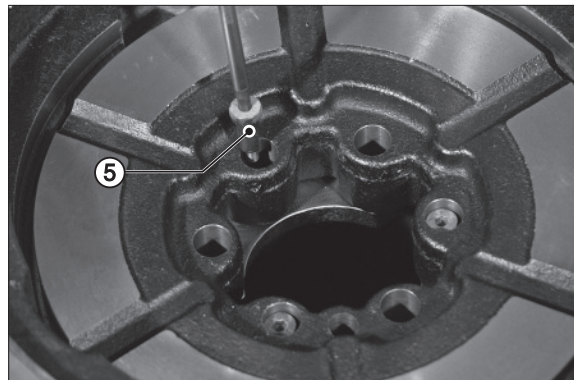

7409FAX048

(9) Slowly introduce low-pressure compressed air through the connection member for the service brake (P1), in order to extract the piston (9).

※ Hold the piston (9) back, as it may be suddenly ejected and damaged.

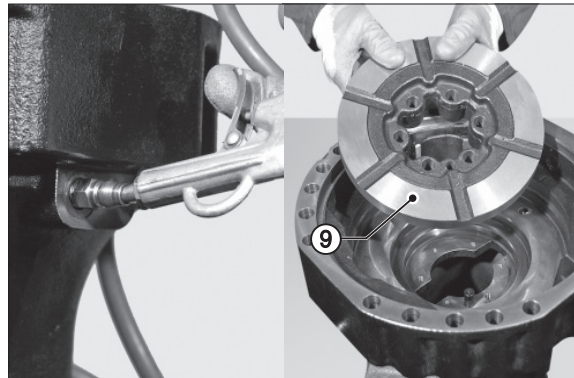

7409FAX049

4) ASSEMBLY SERVICE BRAKE

UPPER VIEW

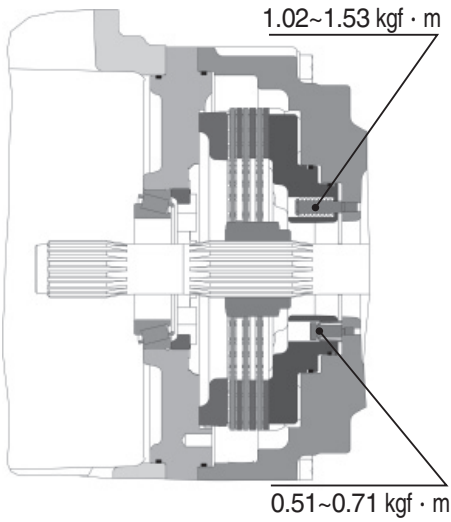

SIDE VIEW

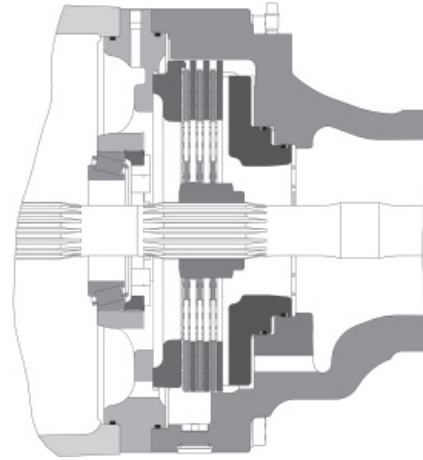

- (1) Insert the stroke automatic regulation springs (6); place them in line with the piston (9).

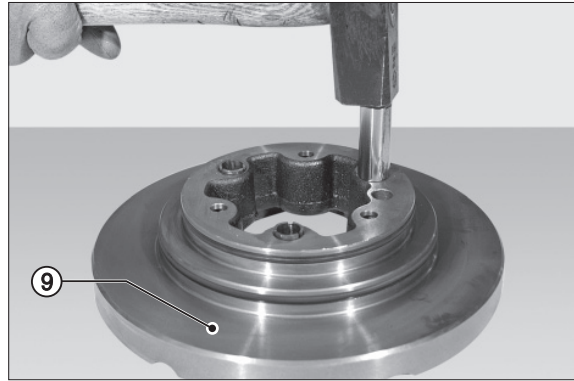

- (2) Fit O-ring (11)(16) and back-up ring (10) (17) onto the piston (11). Lubricate the piston and the O-rings and install the unit into the arm.

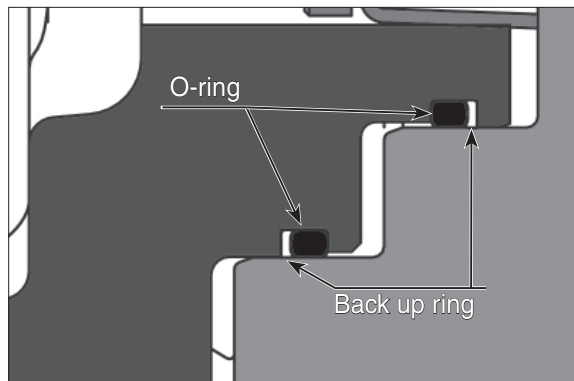
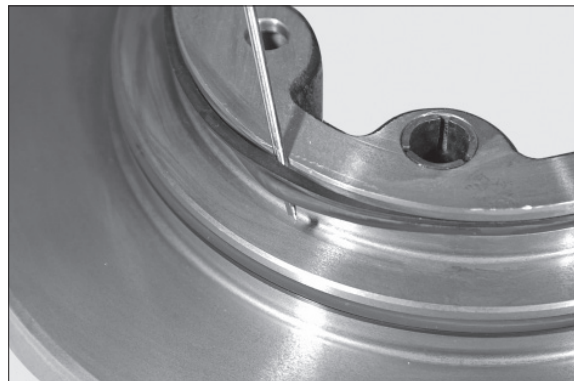

(3) Using a plastic hammer, ram the piston (9) into the arm.

※ Lightly hammer all around the edge in an alternate sequence.

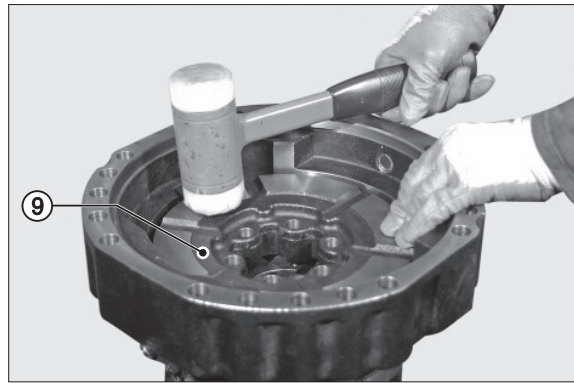

7409FAX055

(4) Fit the adjusting screws (5).
Apply loctite 270 to the thread.

• Torque wrench setting :
0.51 kgf · m (3.69 kgf · m)

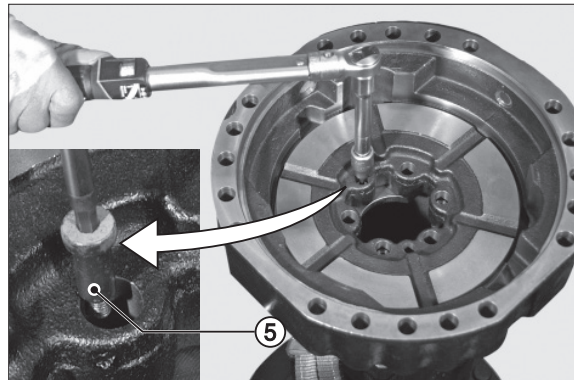

7409FAX056

(5) Fit the reversal springs (8) on the piston (9).

Apply loctite 242 to the thread of the screw.

Tighten with torque wrench setting of
0.51 kgf · m (3.69 lbf · ft).

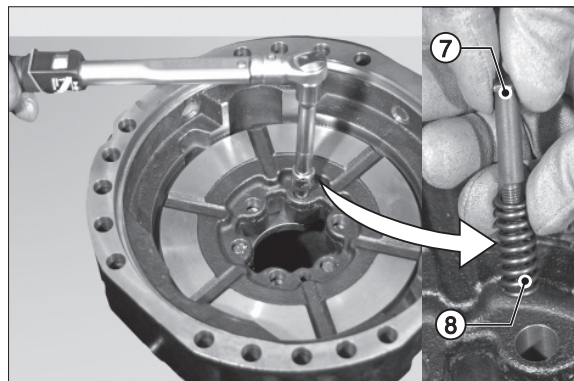

7409FAX057

(6) Grease sealing face "A" of axle shaft .

※ Be very careful not to damage the snap ring .

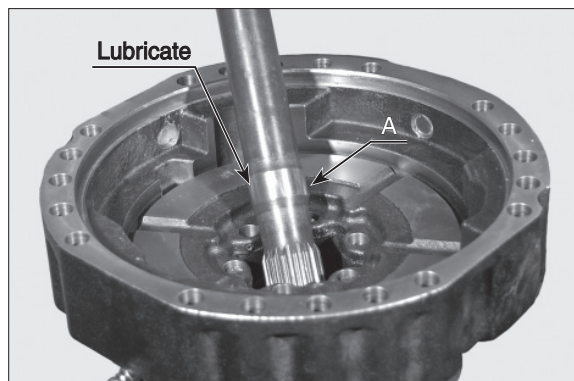

7409FAX058

(7) Insert the brake discs in the right sequence.

※ The first brake disc (3) to be inserted must be of steel material.

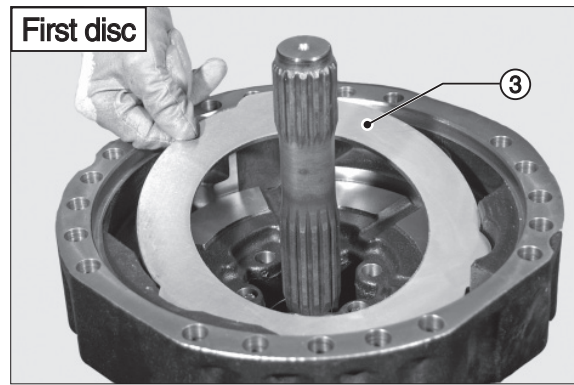

7409FAX059

※ The second brake disc (2) to be inserted must be of friction material.

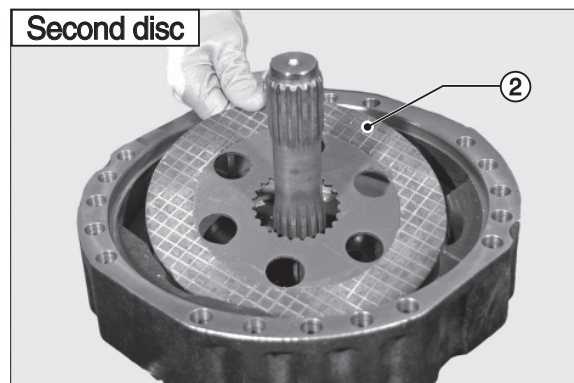

7409FAX060

(8) Install the flange (4) on the arm.

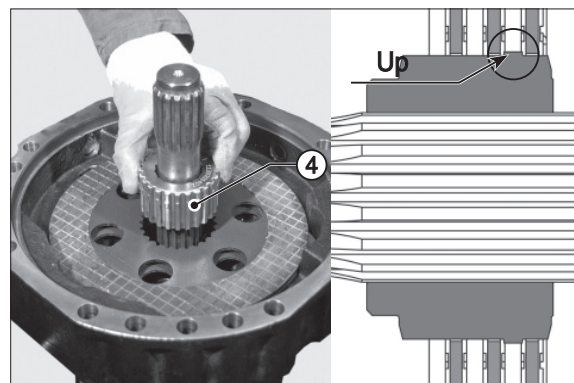

7409FAX061

(9) Insert the intermediate disk (1). Before installing the last brake disc and the intermediate disk, spread grease over the contact surfaces to hold them in position while mounting on the central housing.

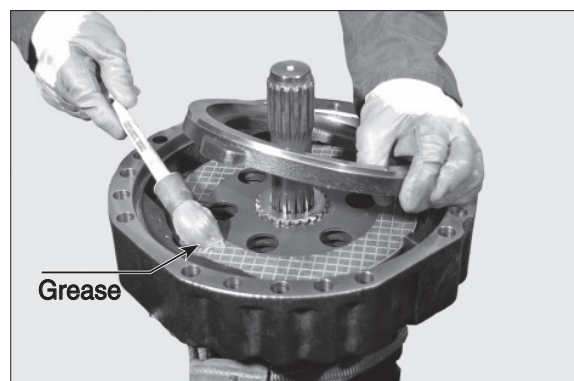

7409FAX062

(10) Check integrity and position of the cylinder's O-ring.

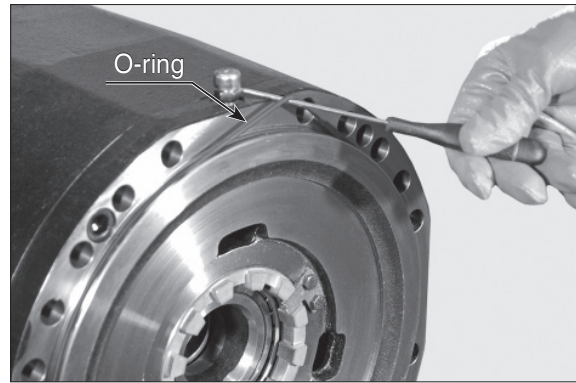

7409FAX063

(11) Temporarily lock the arm with nuts previously coated with loctite 242; tighten lightly to make the unit touch the main body.

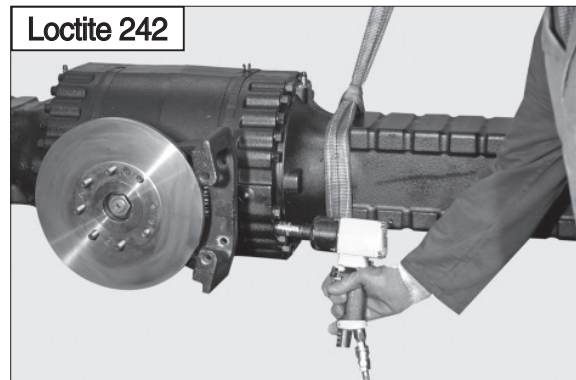

7409FAX064

(12) Check the flatness of the arms, using tool T11; then lock the arms into their final position, using screws adequately coated with loctite 242.

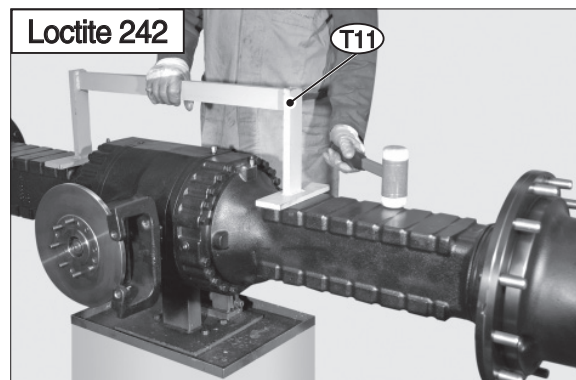

7409FAX065

(13) Secure in position with the screws (3) and relative washers (2), tightening to a torque of 30.4 kgf · m (220 lbf · ft).

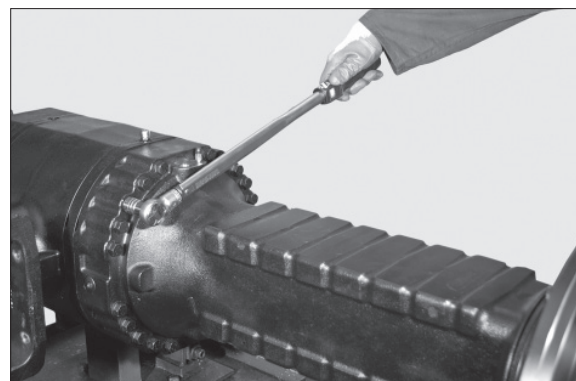

7409FAX066

5) DISASSEMBLY SERVICE BRAKE AND NEGATIVE PARKING BRAKE

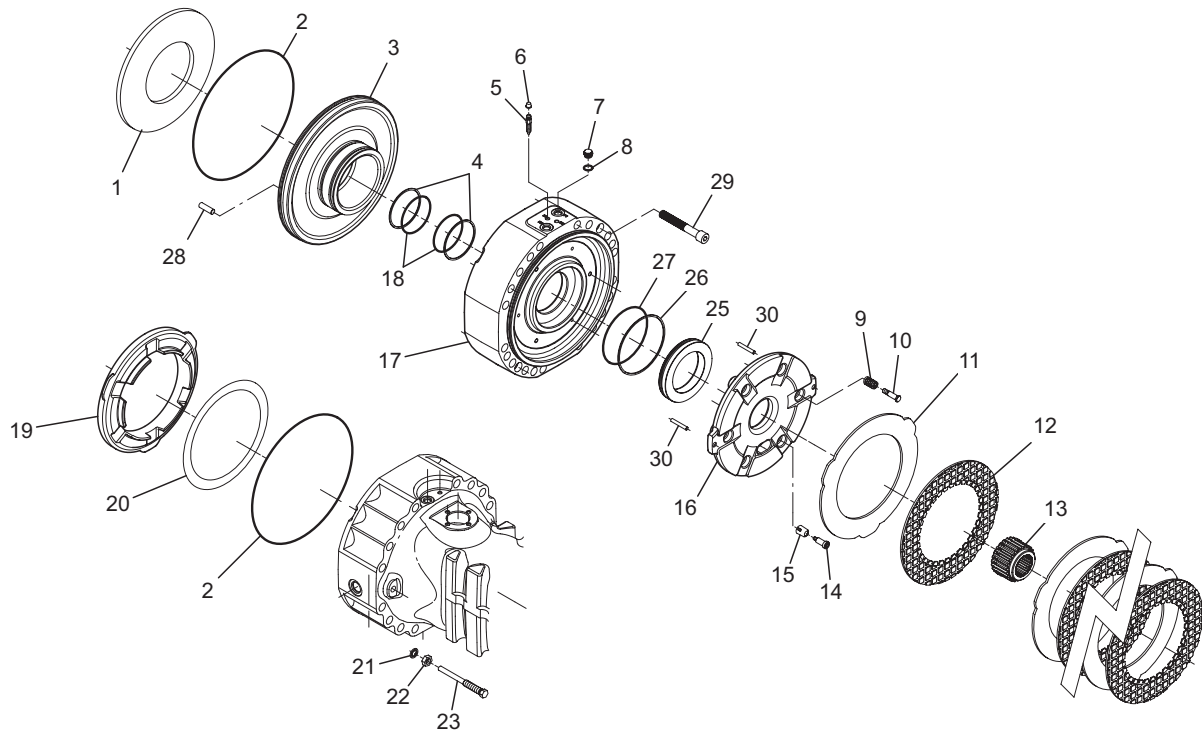

7409FAX067

Manual emergency release

- (1) Loosen nuts (30) of screws (31) provided for the mechanical and manual release of the braking units, then move the nuts backwards by approx. 8 mm.

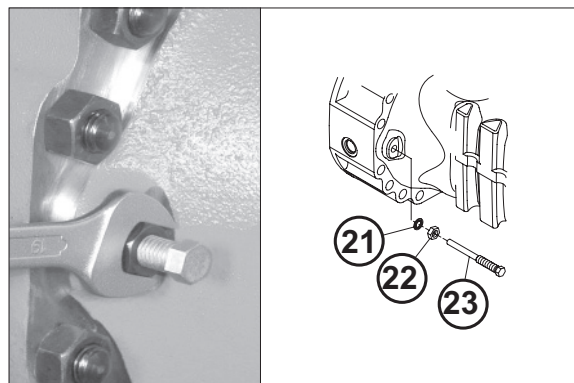

7409FAX068

- (2) Tighten screws (23) so as to fasten them onto the pressure plate (16).

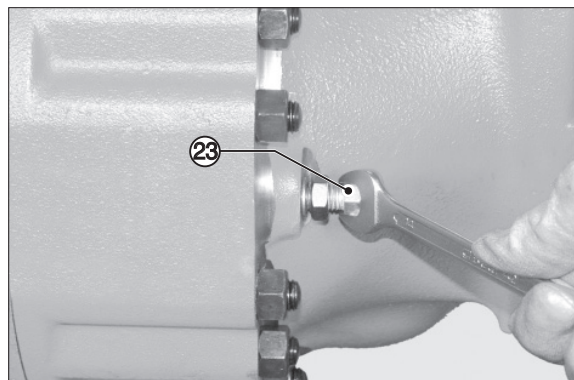

7409FAX069

- (3) Using a wrench, tighten the screws (23) in an alternate sequence by 1/4 turn at a time so as to compress the belleville washers (1) and disengage the braking disks.

※ Tighten max. by one turn.

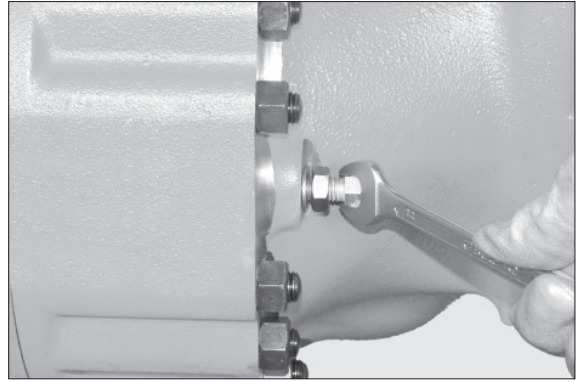

7409FAX070

Adjustment after manual release

- (4) Remove screws complete with nuts and seals. Replace seals, apply silicone-based grease to the screws and install all parts into the arm.

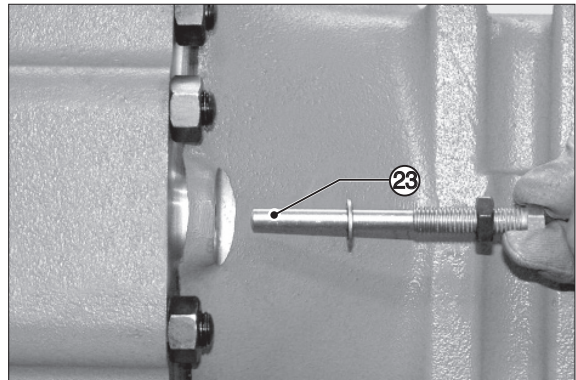

7409FAX071

- (5) Adjust screws (23) to obtain a jut of 30 mm in relation to the arm.

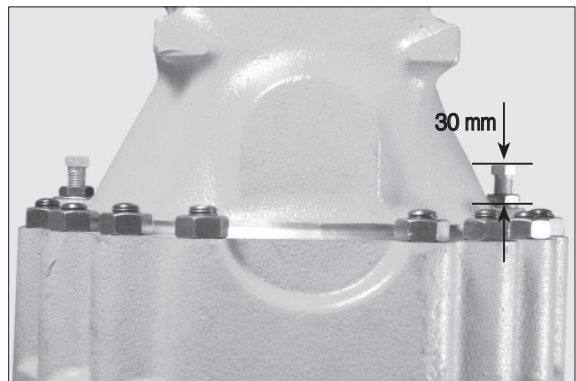

7409FAX072

- (6) Lock into position with nuts (22).

※ Hold screws (23) into position while locking the nuts (22); after locking, check the jut of screws (23) once more.

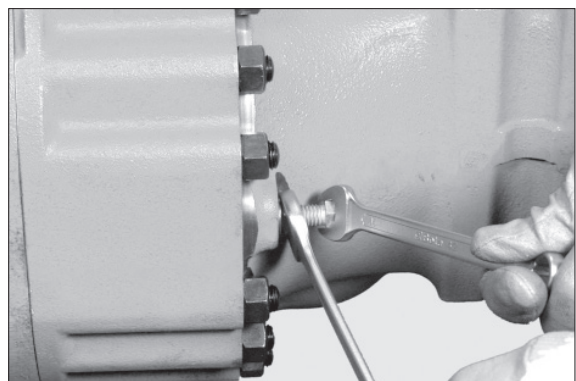

7409FAX073

- (7) Remove fastening screws from the reduction unit.

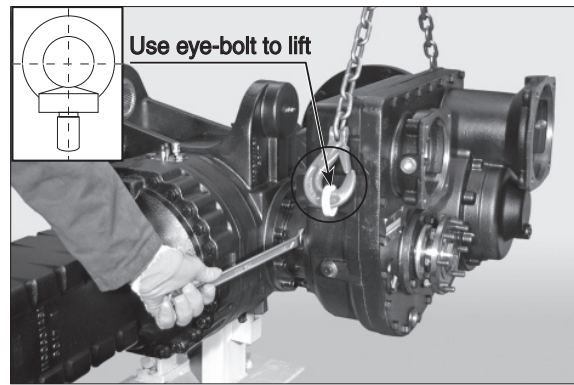

7409FAX074

- (8) Disjoin the entire reduction unit from the axle and place it on a bench.

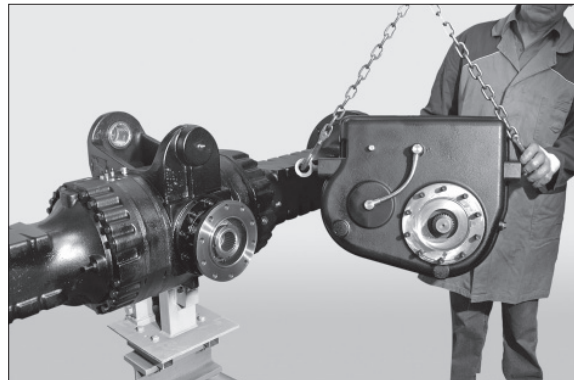

7409FAX075

- (9) Connect an external pump to the union piece "P1" of the negative brake and introduce a pressure of 21.4~35.7 kgf/cm² (304~508 psi) bar to eliminate the pressure of the belleville washers (1).

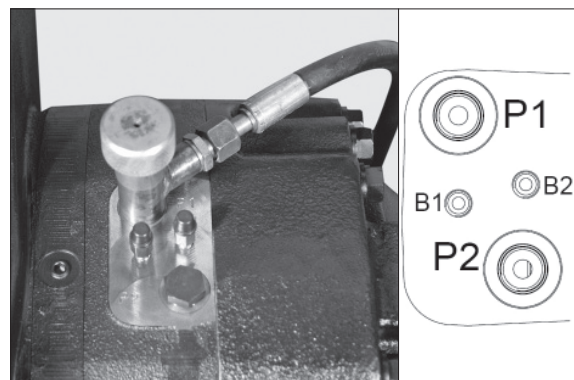

7409FAX076

Checking wear

- ※ The same operations must be carried out on both arms.
- (10) Remove the oil level plug.
Apply the brakes once and, while keeping the pressure up, check thickness "S" between the intermediate brake discs.
Minimum "S" value : 5.2 mm.
- ※ If necessary, replace brake discs and intermediate discs on both sides.

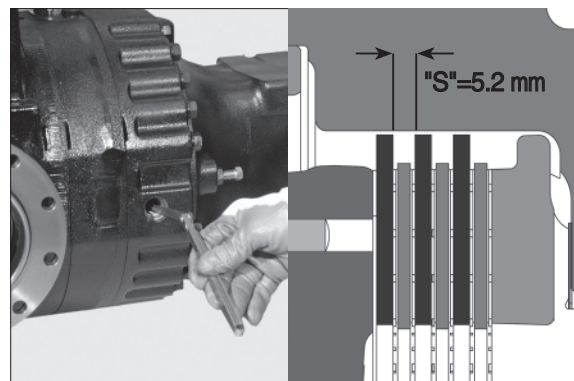

7409FAX077

- ※ If axle is positioned on an overhaul bench, place a safety antitilting stand “B” under the arm that remains connected and block wheels, if any.

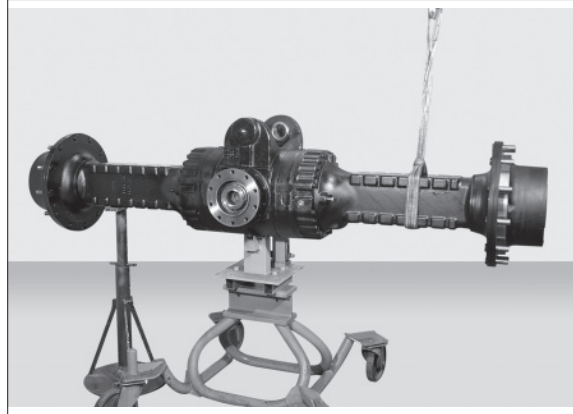

7409FAX078

- (11) Sling the arm to be removed and connect it to a hoist.
Remove the retainer screws and relative washers.

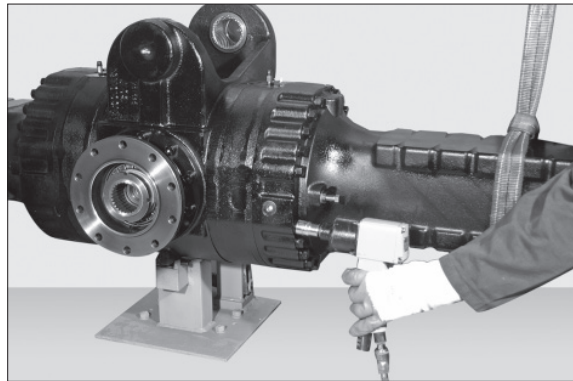

7409FAX079

- (12) Remove arm together with brakes and axle shafts; lay down the arm vertically.
Release pressure.

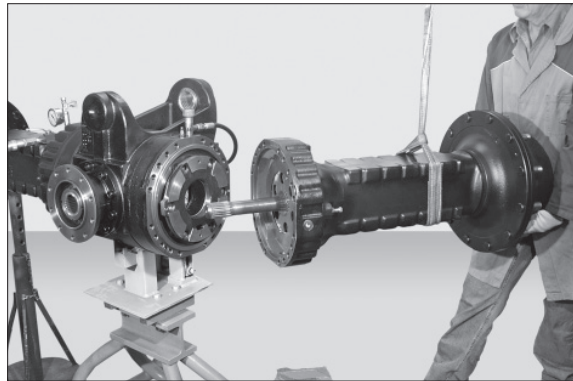

7409FAX080

- (13) Remove braking discs (11)(12), noting down direction of assembly.
 - ※ If disks are not to be replaced, avoid changing their position.

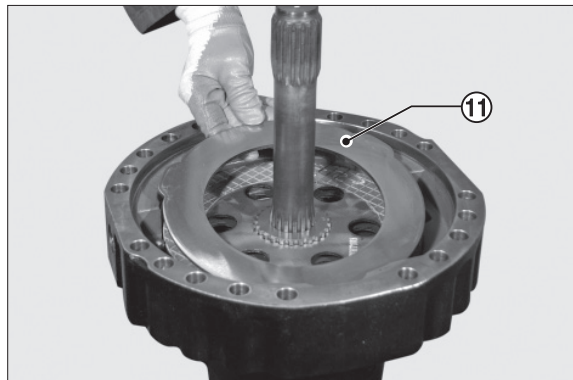

7409FAX081

- (14) Remove the flange (13) complete with the discs.
Noting down direction of assembly.

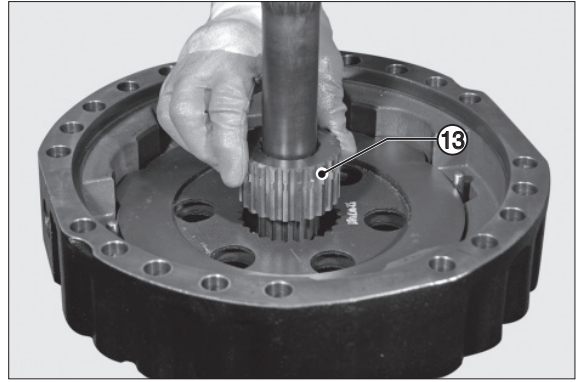

7409FAX082

- (15) Remove distance piece-braking discs (19) and shims (20), noting down direction of assembly.

- ※ Build a stack of washers and check the measure.

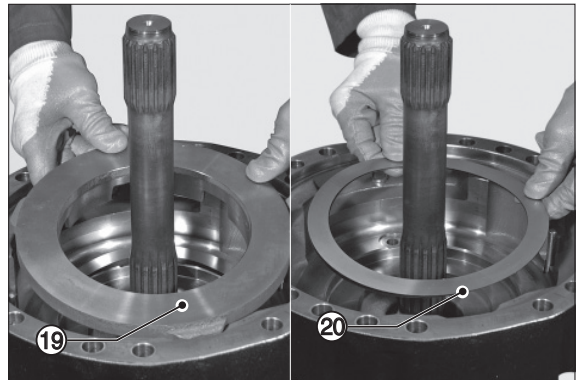

7409FAX083

- (16) Remove the adjusting screws (14) from the counterwasher (16).

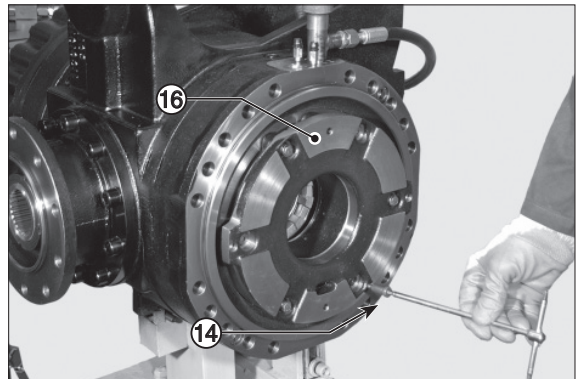

7409FAX084

- (17) Remove the reversal springs (9) and screws (10).

- ※ If the springs (9) are weak or deformed they must be replaced.

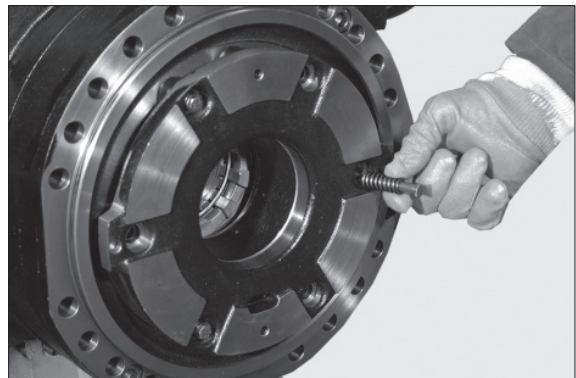

7409FAX085

(18) Note down their order of assembly and remove the counterwasher (16).

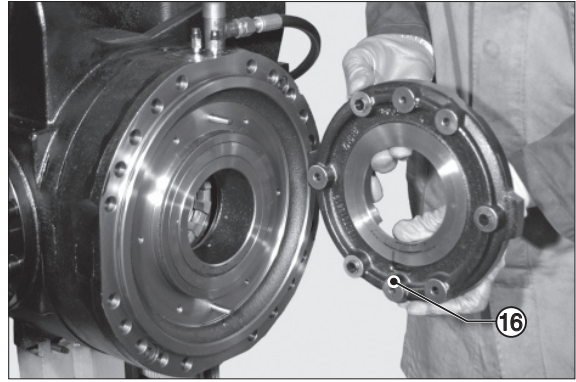

7409FAX086

(19) Loosen the fixing screws (29) in an alternate manner and remove them.

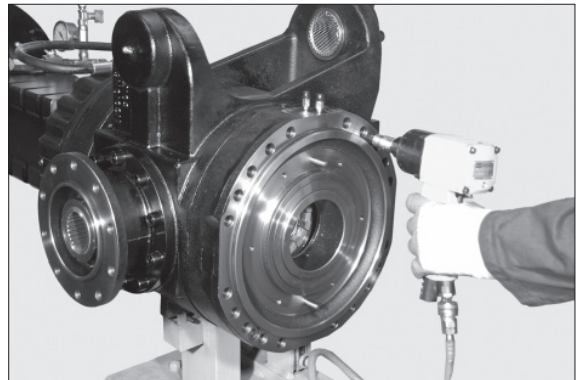

7409FAX087

(20) Remove the brake cylinder (17).

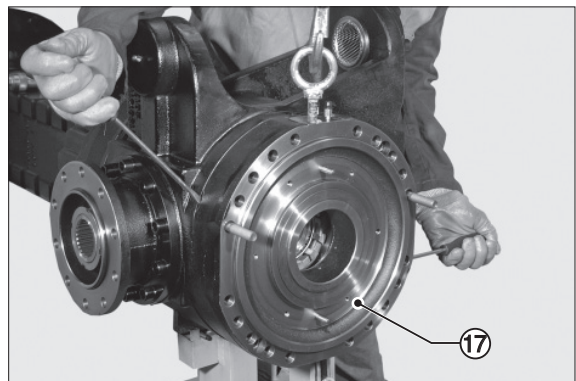

7409FAX088

(21) Move the cylinder (17) outwards while supporting the belleville washers (1). Remove the belleville washers (1) and note down direction of assembly.

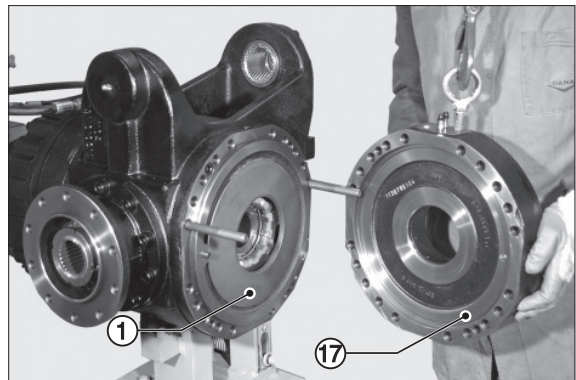

7409FAX089

(22) Slowly introduce low-pressure compressed air through the connection member for the service brake (P2), in order to extract the piston (25).

- ※ Hold the piston (25) back, as it may be suddenly ejected and damaged.

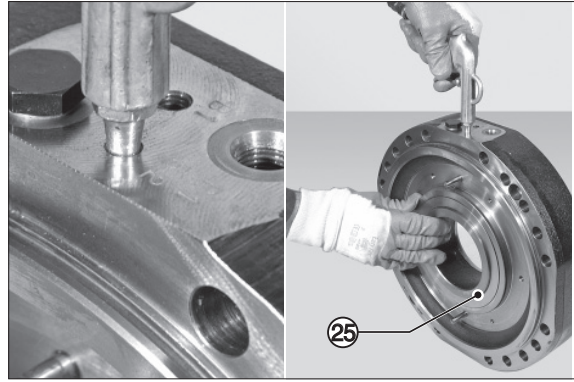

7409FAX090

(23) Slowly introduce low-pressure compressed air through the connection member for the negative brake (P1), in order to extract the piston (3).

- ※ Hold the piston (3) back, as it may be suddenly ejected and damaged. Note down their order of assembly.

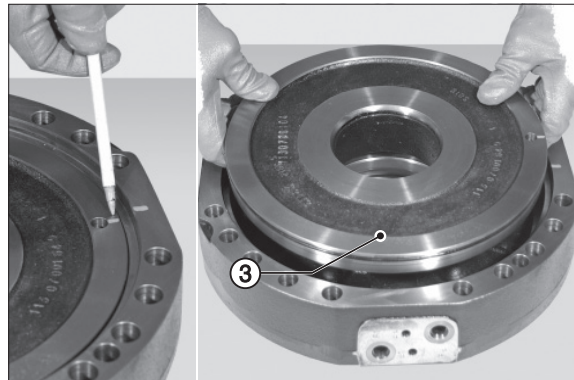

7409FAX091

6) ASSEMBLY SERVICE BRAKE AND NEGATIVE PARKING BRAKE

UPPER VIEW 1.02~1.53 kgf · m, loctite 242

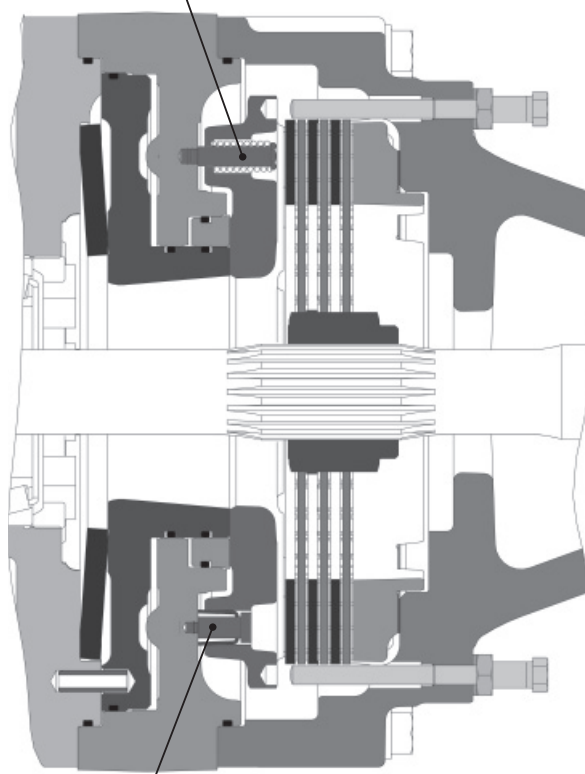

0.51~0.71 kgf · m, loctite 270

7409FAX092

SIDE VIEW

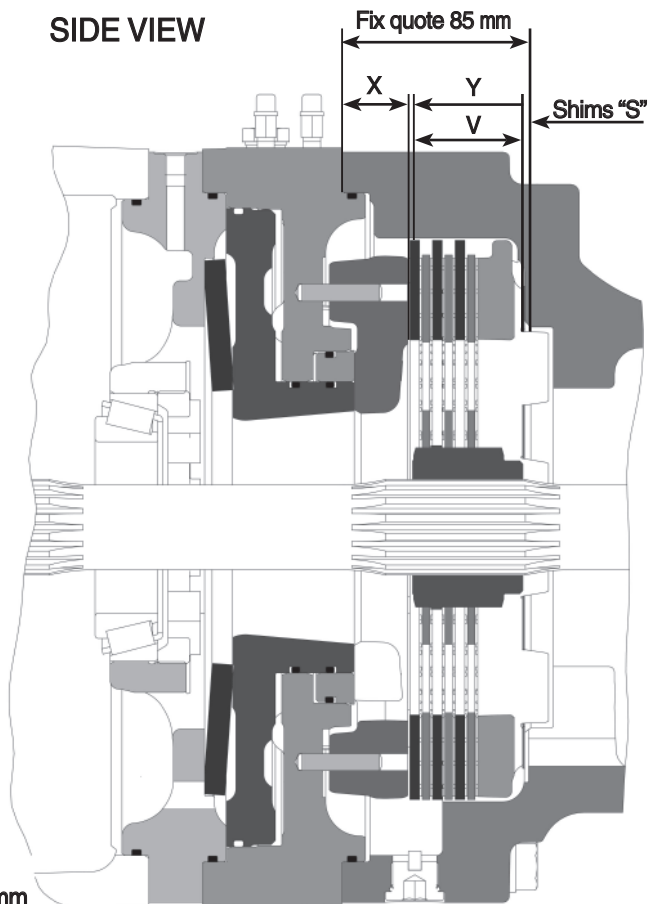

85 mm = arm fix quote

Y = 1 mm brake gap

Example :

X = 30.6 mm

V = 52.9 mm

$S = 85 \text{ mm} - (x + y + v)$

$S = 85 - (30.6 + 1 + 52.9) = 0.5 \text{ mm}$

7409FAX093

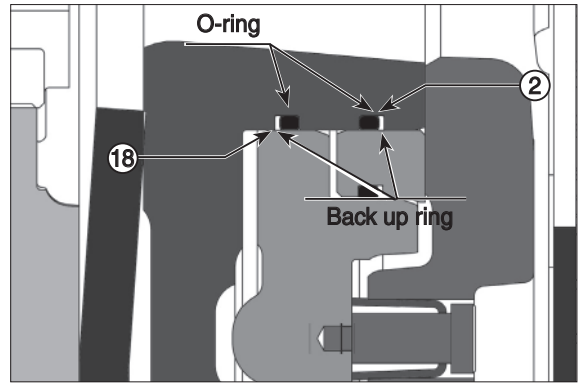

7409FAX094

- (1) Fit O-ring (2) and (4) and anti-extrusion ring (18) onto the piston (3).

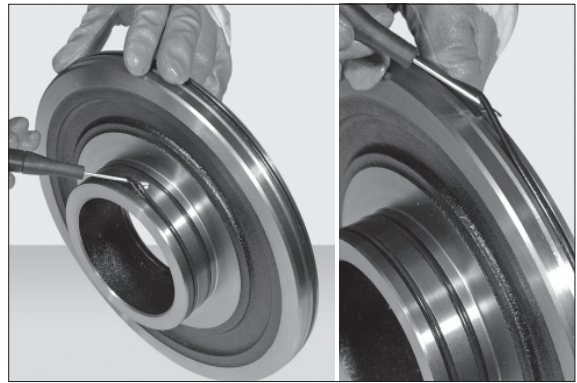

7409FAX095

- (2) Check the position of the anti-extrusion (18) and O-rings (2) and (4).
Lubricate the piston and the O-rings and install the unit (3) into the cylinder (17) .

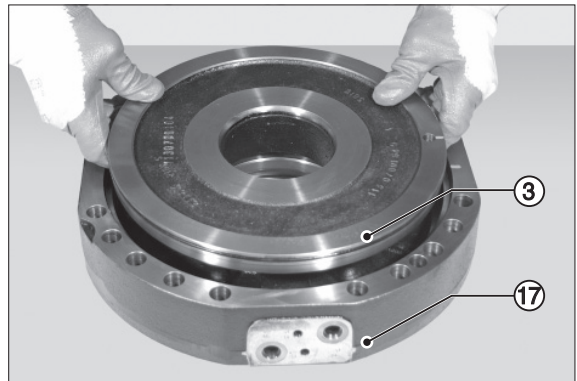

7409FAX096

- (3) Using a plastic hammer, ram the piston (3) into the cylinder (17).

- ※ Lightly hammer all around the edge in an alternate sequence.

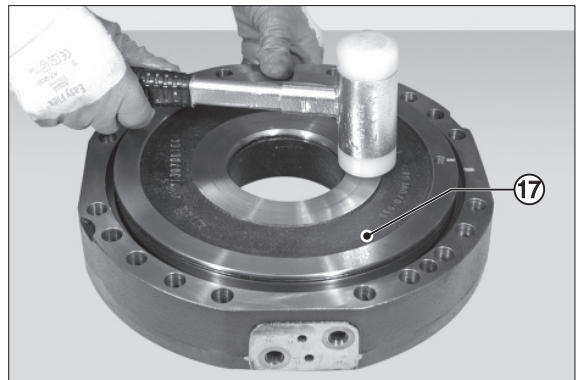

7409FAX097

- (4) Fit O-ring (27) and anti-extrusion ring (26) onto the piston (25).

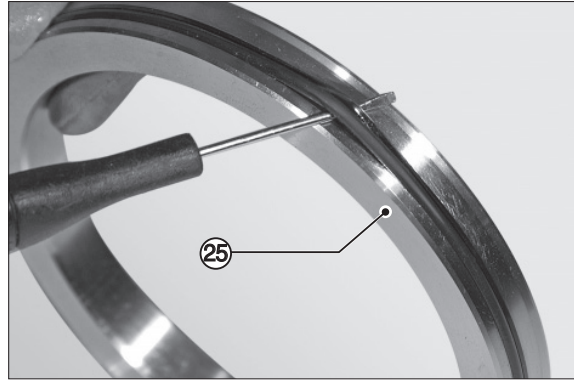

7409FAX098

- ※ The O-rings always have to be assembled from the pressure facing side.

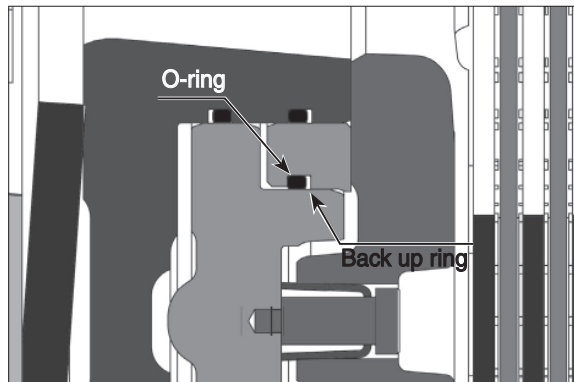

7409FAX099

- (5) Lubricate the piston and the O-rings and install the unit (25) into the cylinder (17) .

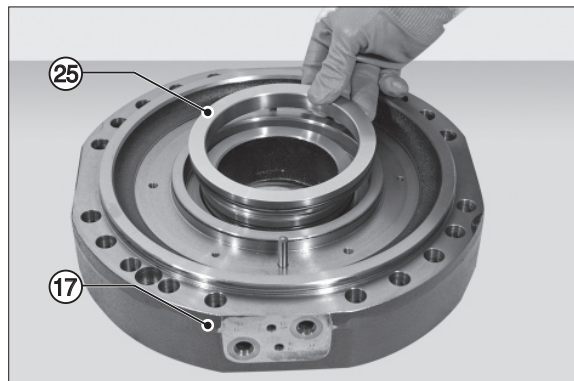

7409FAX100

- (6) Using a plastic hammer, ram the piston (25) into the cylinder (17).

- ※ Lightly hammer all around the edge in an alternate sequence.

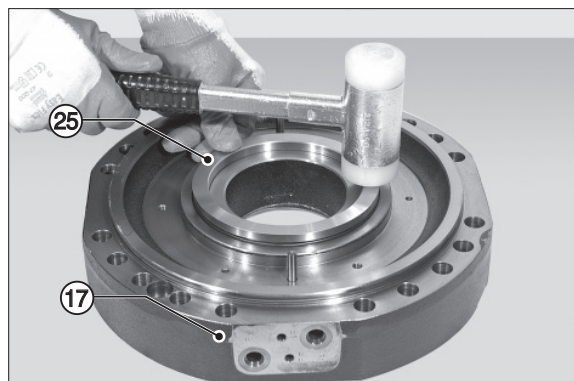

7409FAX101

(7) Assembly the breather (5).

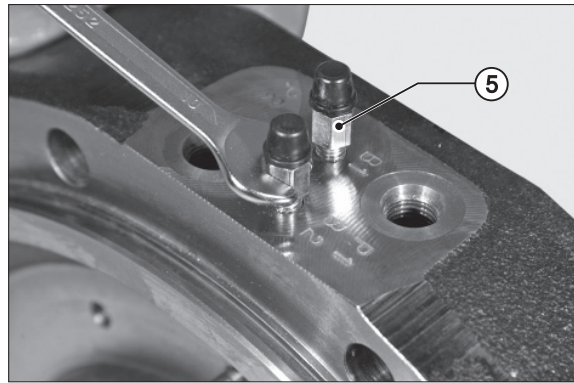

7409FAX102

(8) Check integrity and position of the cylinder's O-ring (2).

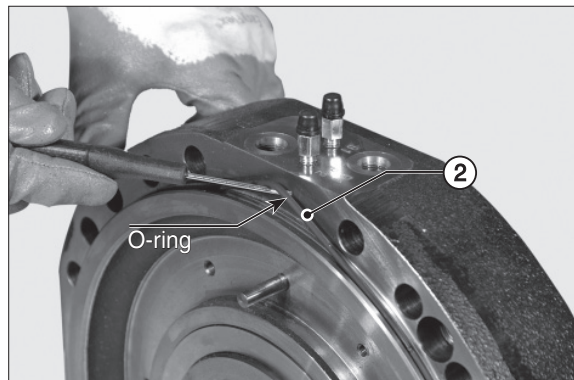

7409FAX103

(9) Position the belleville washers (1) and engage the cylinder, spread grease over the contact surfaces to hold them in position while mounting on the central housing.

※ Check the sense of direction of belleville washers (1) and relative centring.

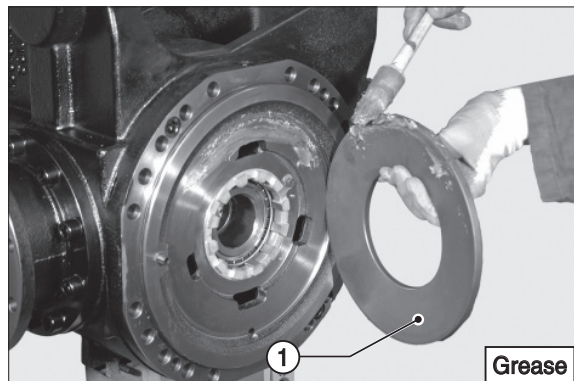

7409FAX104

(10) Engage the cylinder (17).

※ Check the sense of direction of washers (1) and relative centring.

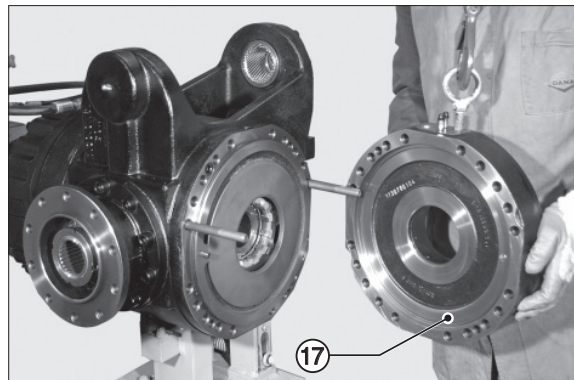

7409FAX105

- (11) Insert the screws (29) and tighten them alternately.
Lock the cylinder (17).

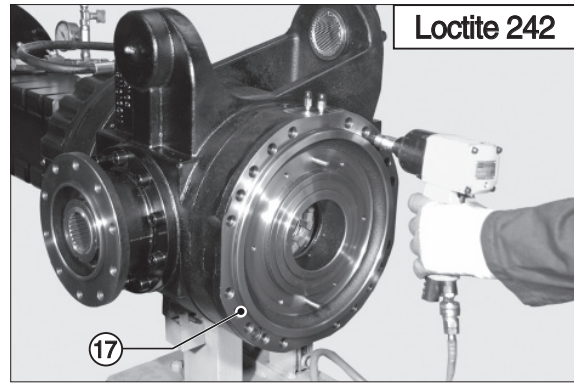

7409FAX106

- (12) Tightening the screws (29) with a dynamometric wrench set to a torque of 3.1~3.57 kgf · m (22.4~25.8 lbf · ft).

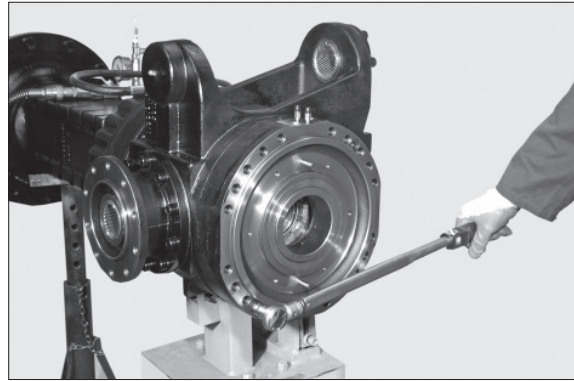

7409FAX107

- (13) Insert the stroke automatic regulation springs (15); place them in line with the intermediate disc (19).

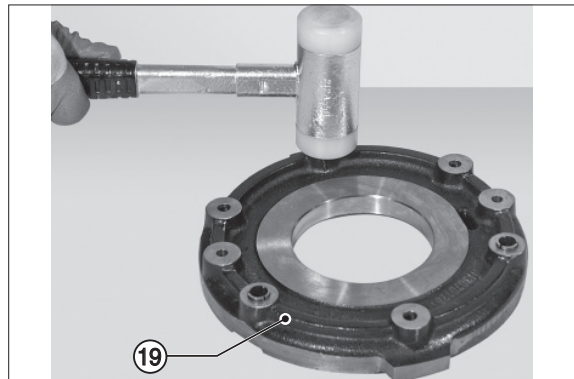

7409FAX108

- (14) Insert the intermediate disc (19).
Connect an external pump to the negative brake and introduce pressure to 20.4~35.7 kgf/cm² (290~507 psi)

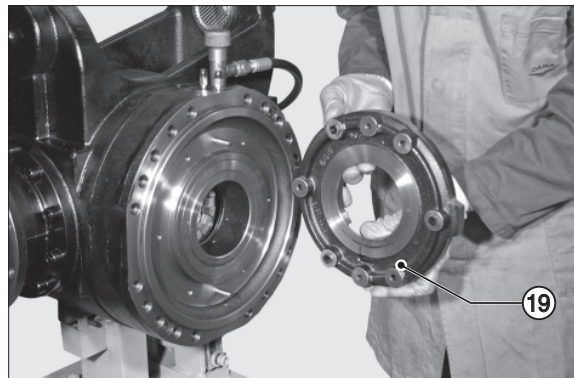

7409FAX109

- (15) Fit the reversal springs (9) and screws (10) on the intermediate disk (16).
 Apply loctite 242 to the thread of the fixing screw.
 Tighten with torque wrench setting of 1.02~1.53 kgf · m (7.38~11.1 lbf · ft)

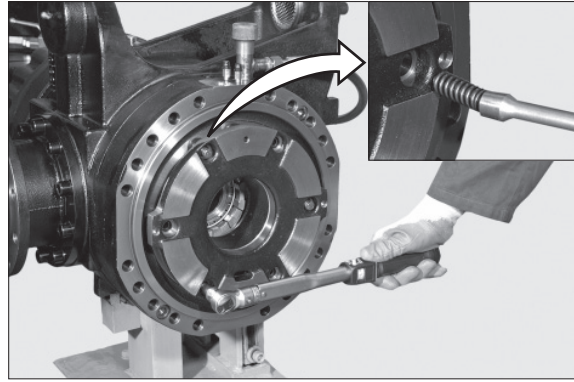

7409FAX110

- (16) Fit the adjusting screws (14).
 Apply loctite 270 to the thread.
 · Torque wrench setting :
 0.51~0.71 kgf · m (3.69~5.14 lbf · ft)

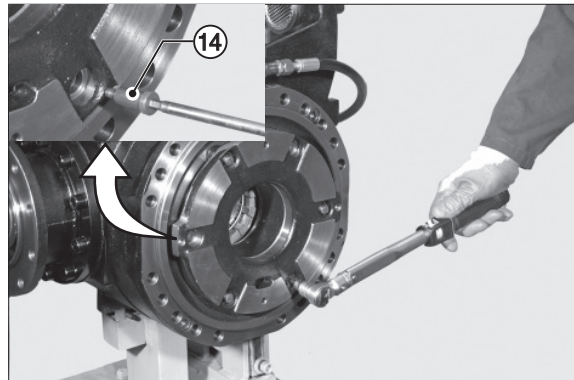

7409FAX111

- (17) Take the measure from the surface of the intermediate disk to the cover sealing surface with 20.4~35.7 kgf/m² (290~507 psi) of pressure introduced.

Example : X = 30.6 mm

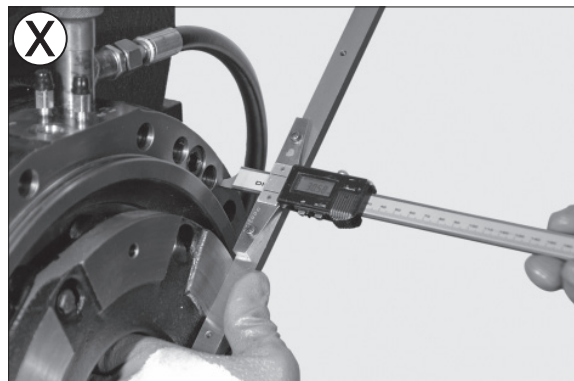

7409FAX112

- (18) Put the brake disc pack including the shim under a press, load with 1000 kg and take the measure "V".

Example : V = 52.9 mm

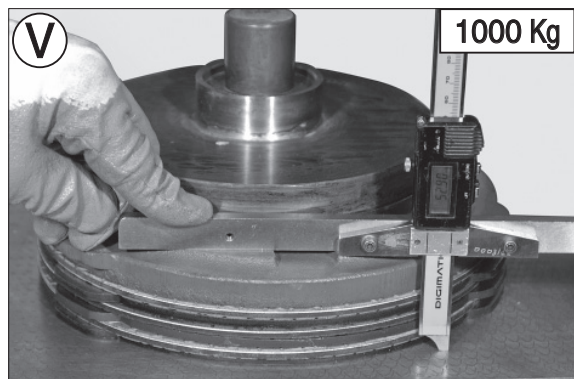

7409FAX113

(19) Arm fix quote = 85 mm

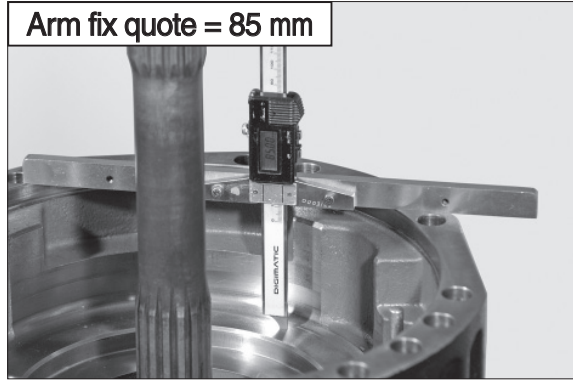

7409FAX114

(20) $S = 85 \text{ mm} - (x + y + v) =$ Thickness of shims to insert under the shim washer.

Example :

$$85 \text{ mm} - (30.6 + 52.9 + 1) = S = 0.5 \text{ mm}$$

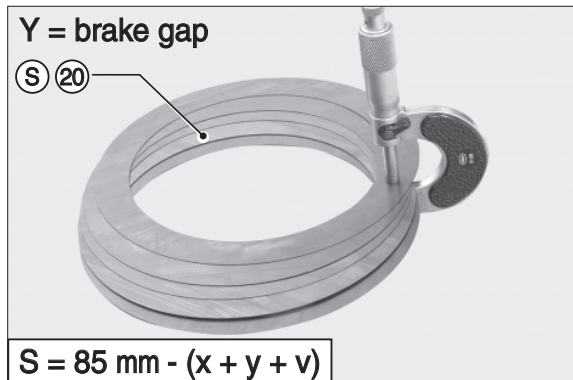

7409FAX115

(21) Insert under the shim washer a thickness of shims (20).

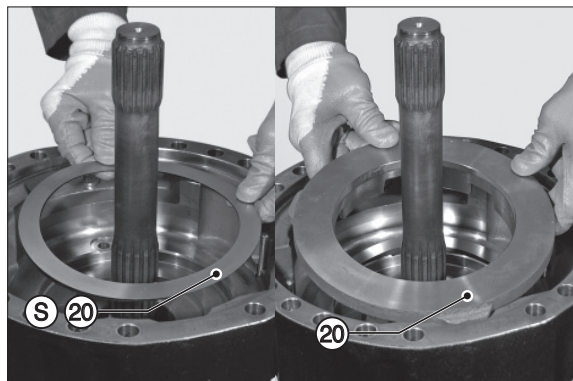

7409FAX116

(22) Slightly lubricate the braking disks (11) and (12) and fit them in the arm following the correct sequence; orient them so that the oil circulation holes and the marks "B" are perfectly lined up.

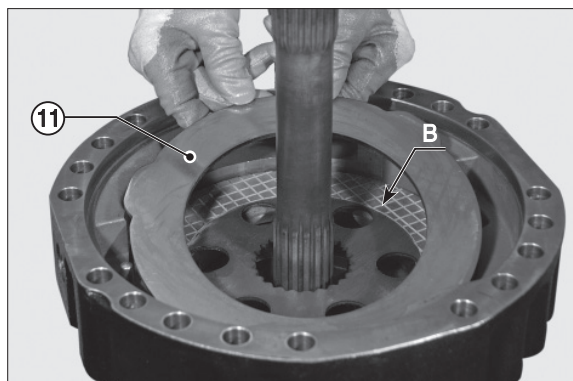

7409FAX117

(23) Install the flange (13) on the arm.

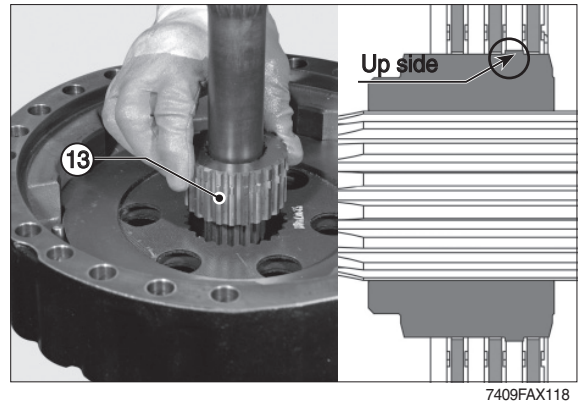

(24) Insert the brake discs (11) and (12) in the right sequence.

※ The last brake disc to be inserted must be in metal.

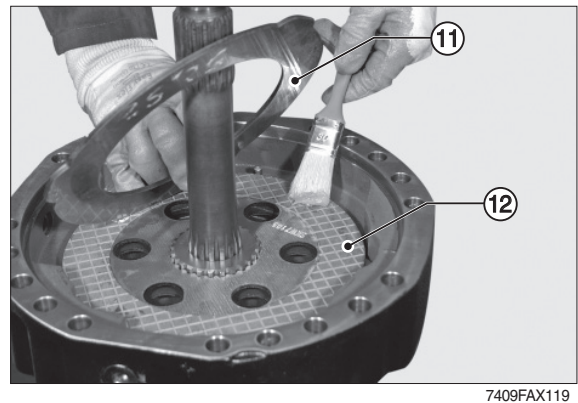

(25) Check integrity and position of the arm's O-ring; install the complete arm.

※ To assist axle shaft centring, slightly move the wheel hub.

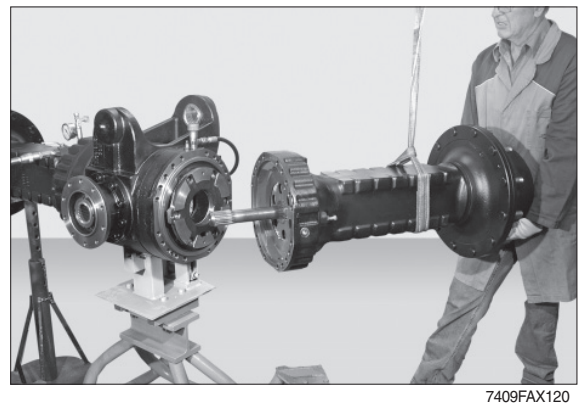

7409FAX120

(26) Temporarily lock the arm with nuts previously coated with loctite 242; tighten lightly to make the unit touch the main body.

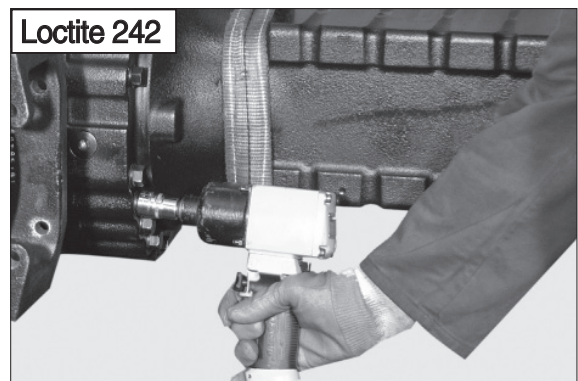

(27) Check the flatness of the arms, using tool T11; then lock the arms into their final position, using screws adequately coated with loctite 242.

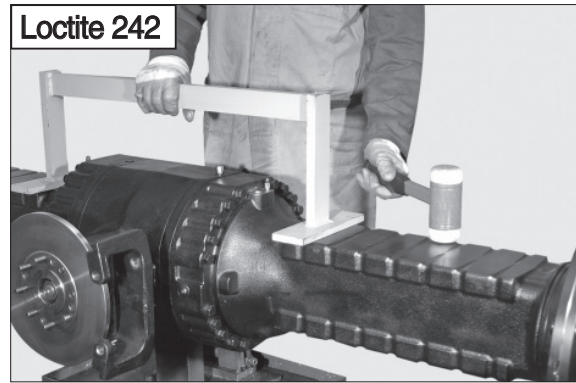

7409FAX122

(28) Secure in position with the screws and relative washers, tightening to a torque of 30.4 kgf · m (220 lbf · ft).

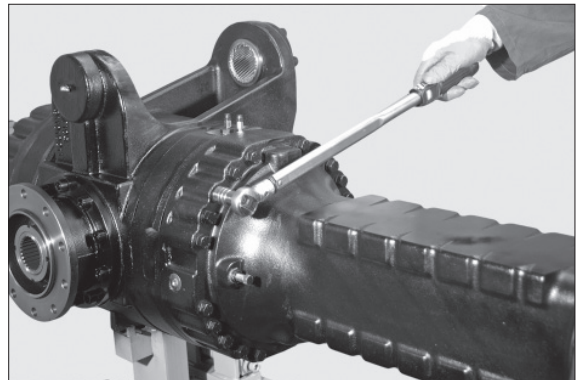

7409FAX123

7) DISASSEMBLY LIMITED SLIP 45% DIFFERENTIAL UNIT

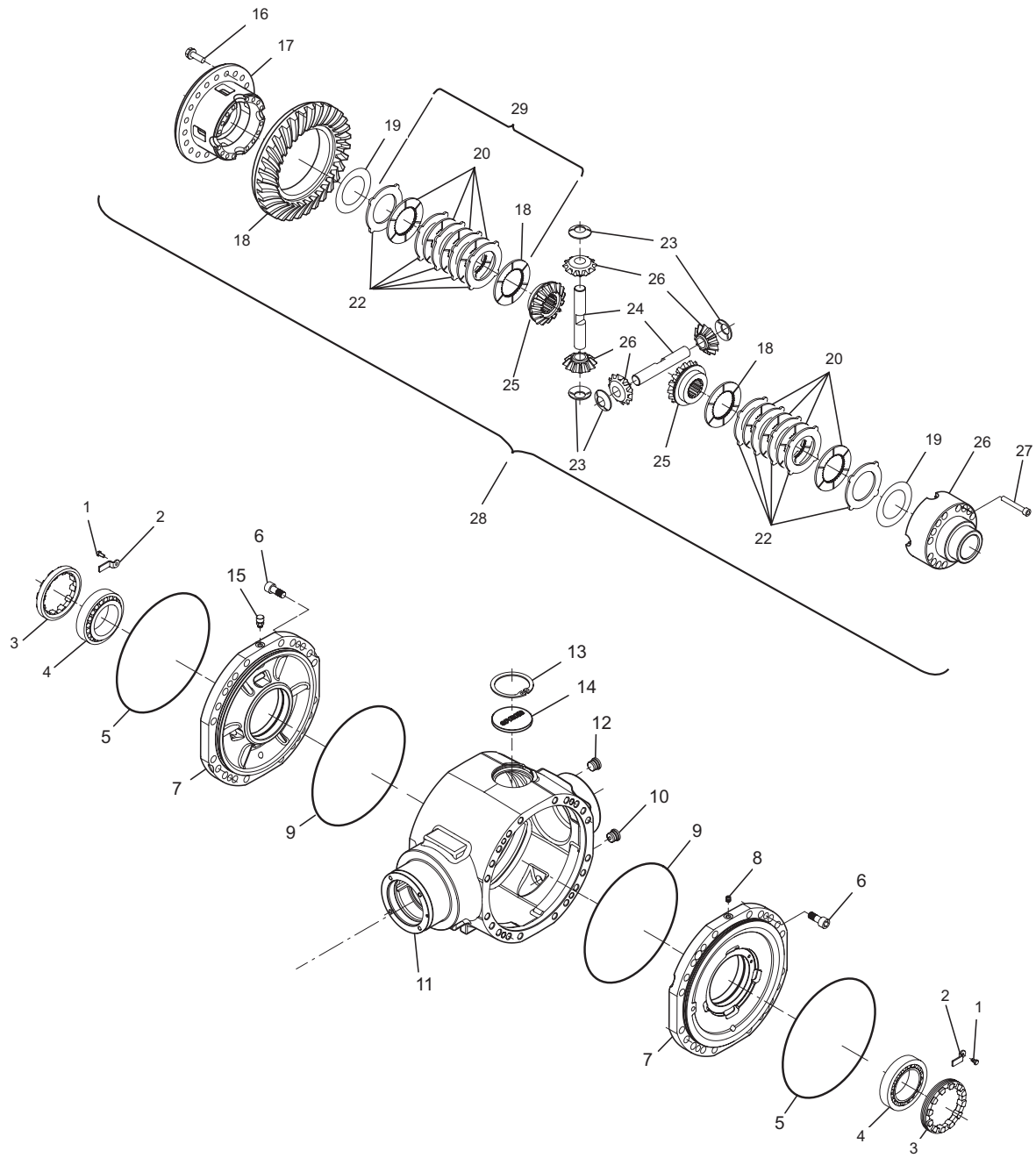

7409FAX124

- (1) Sling the arm to be removed and connect it to a hoist.
Remove the retainer screws and relative washers.

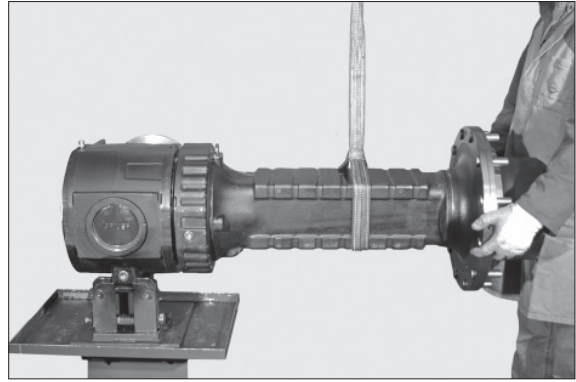

7409FAX125

- (2) Only if need removing or adjusting.
Mark the position of the ring nuts (3).
Remove screws (1) and ring nut checks (2).

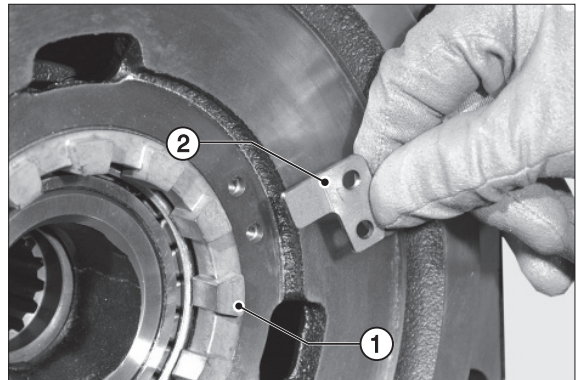

7409FAX126

- (3) Only if need removing or adjusting. Using tool T4, loosen and remove the ring nuts (3).

※ Accurately remove any trace of sealant from the threads of ring nuts and intermediate covers.

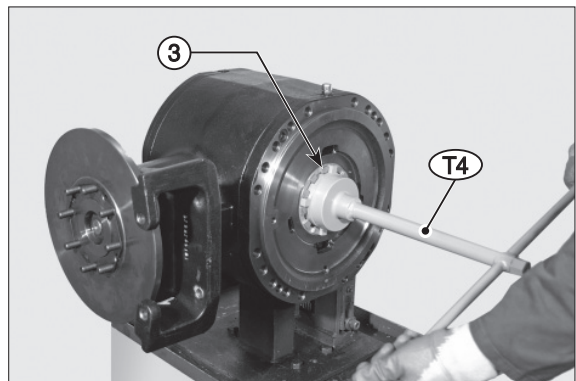

7409FAX127

- (4) Tighten two safety M16 studs in the main body.
Loosen and remove the check screws (6) of intermediate cover (7) on gear ring side.

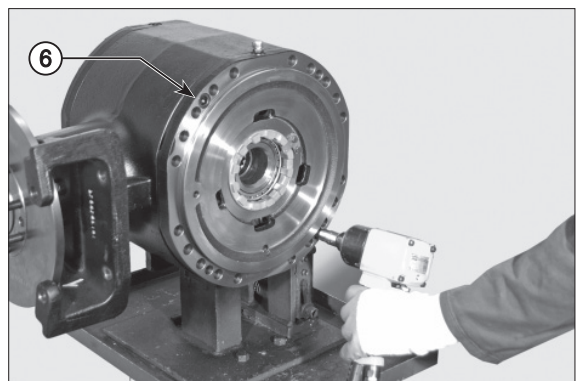

7409FAX128

(5) Disjoin the cover (7) crown side.

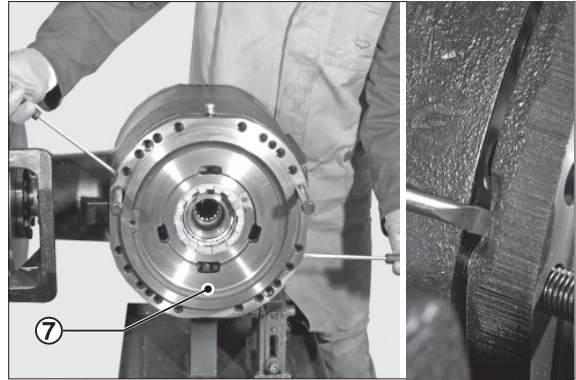

(6) Remove the cover and studs.

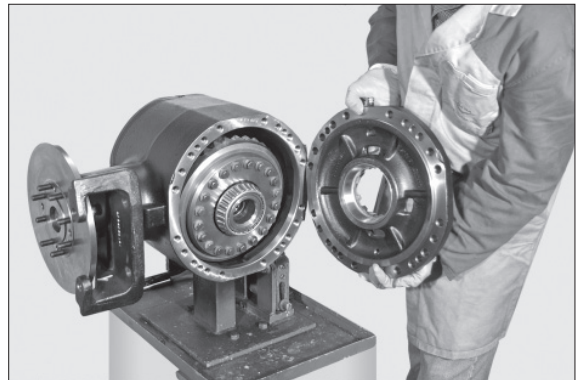

(7) Extract the whole differential unit (28).

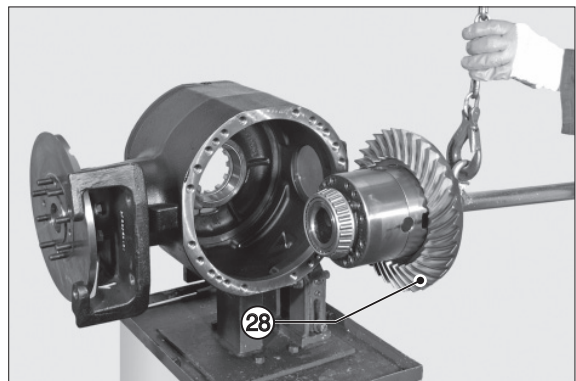

(8) Tighten two safety M16 studs in the main body.

Loosen and remove the check screws (6) of intermediate cover (4) on gear ring side.

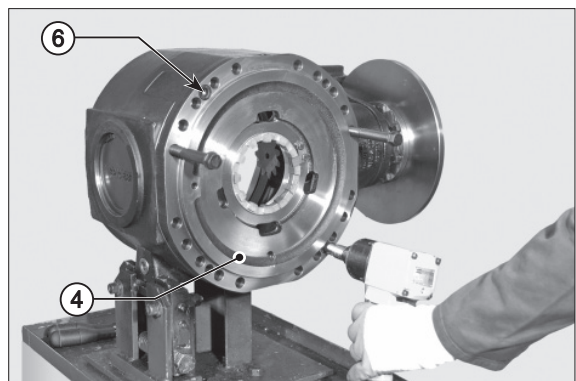

(9) Remove the snap ring (13).

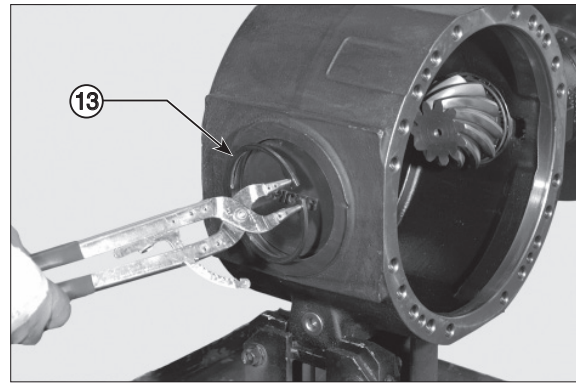

7409FAX133

(10) Remove the cap (14).

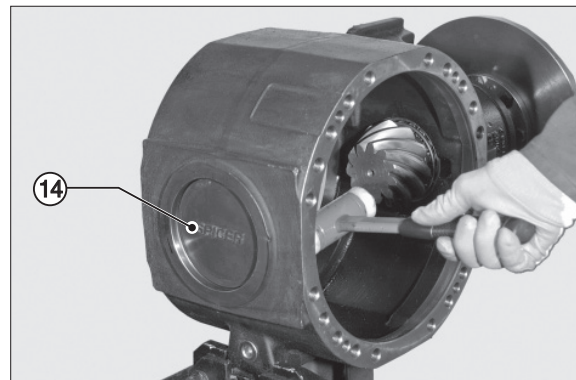

7409FAX134

(11) If the bearings need replacing, extract the external thrust blocks of the bearings (4) from middle cover (7).

※ Accurately check the O-ring (9).

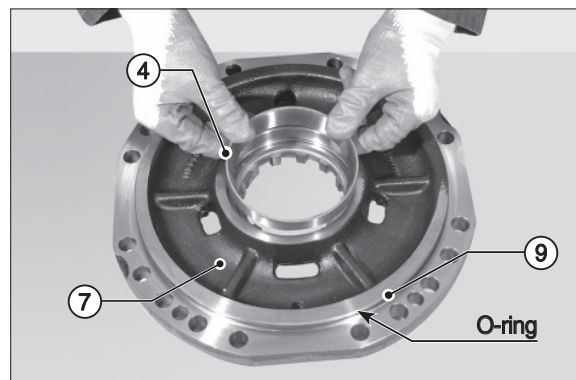

7409FAX135

(12) If the bearing need replacing, extract the bearings (4) from the differential carrier (28).

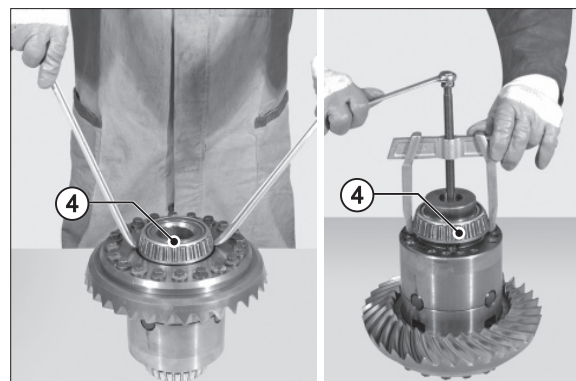

7409FAX136

(13) Remove the fitting screws (16) of the crown (18).

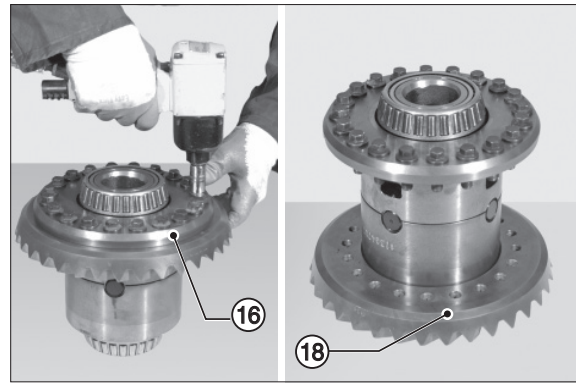

(14) Remove the screws (27) jointing the differential unit half box.

※ Note down the coupling marks.

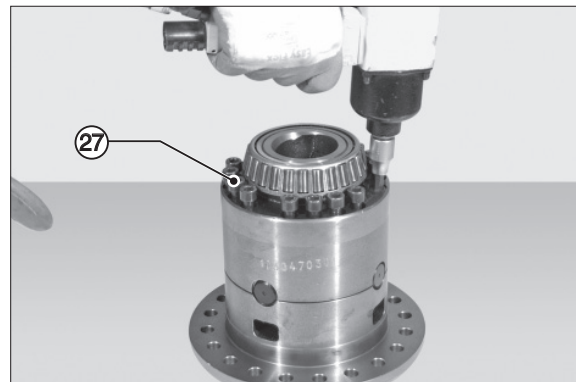

(15) Remove the upper half box (26) and pull out shims (19) and clutch pack (29).

※ If the clutch pack does not need replacing, avoid swapping discs position.

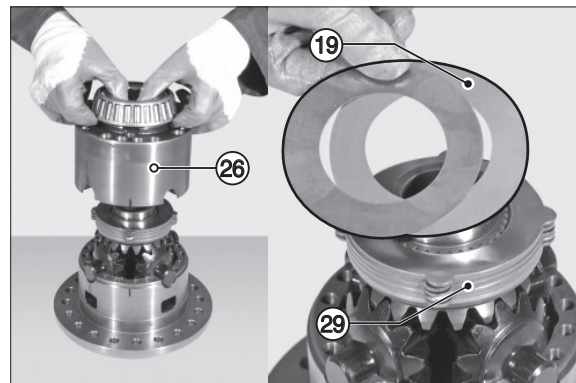

(16) Remove the planet gear (25).

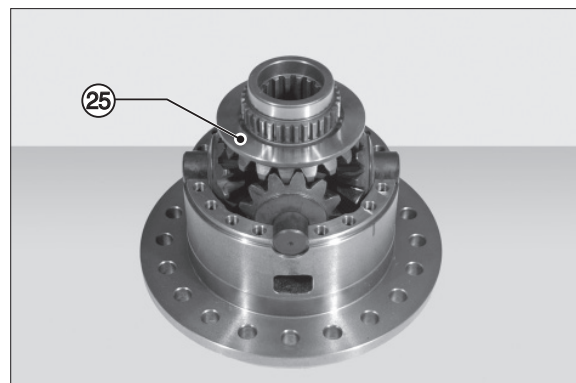

(17) Remove shafts (24), complete with planet wheels (26) and spherical shoulder washers (23).

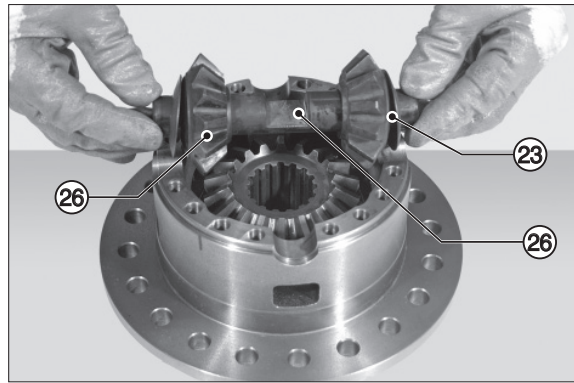

7409FAX141

(18) Extract from the differential unit (17) the two final planet gears (26), the 2nd planet gear (25).

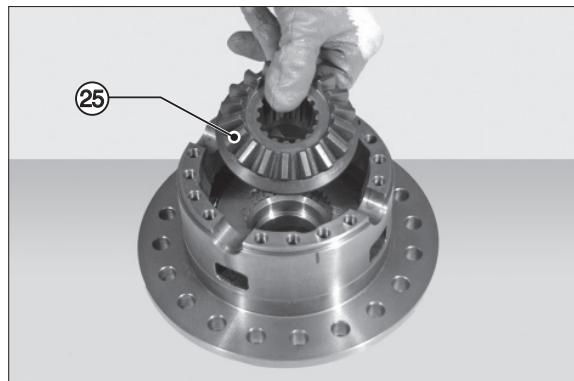

7409FAX142

(19) Remove the 2nd clutch pack (29) and shim set (19).

※ If the clutch pack does not need replacing, avoid swapping discs position.

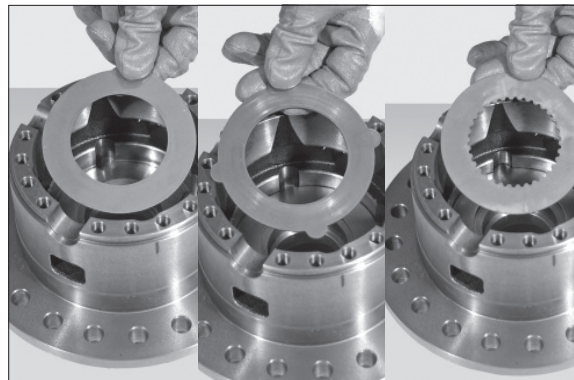

7409FAX143

8) ASSEMBLY LIMITED SLIP DIFFERENTIAL UNIT 45%

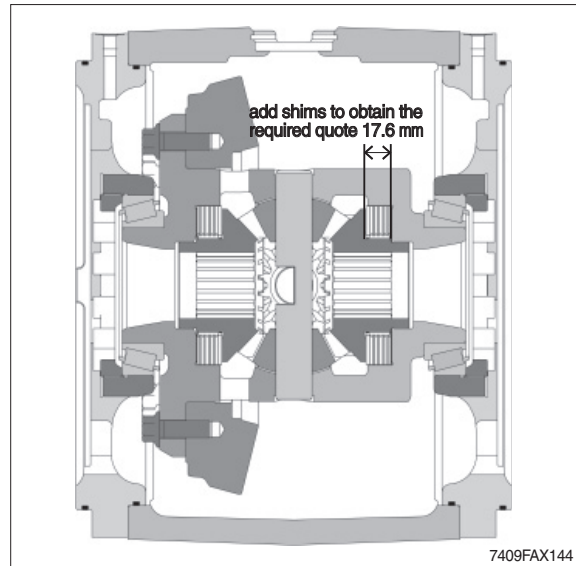

- (1) Only in case of clutch pack replacement: make up the packs with increased shims (18), clutch discs (20), intermediate discs (22) and shims (19).

※ Add shims (19) until a total size of 17.6 mm is obtained.

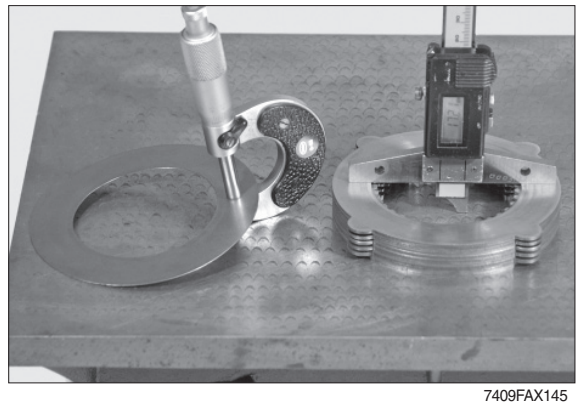

- (2) Fit shims (19) and clutch pack (29) sequentially.

※ When installing the increased disc, place shim so that it leans against the crown wheel (25).

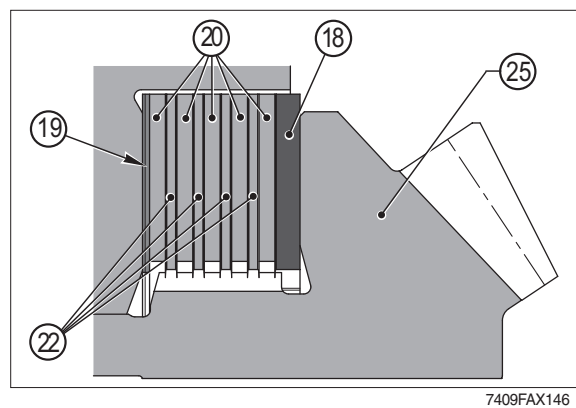

(3) Install crown wheel (25).

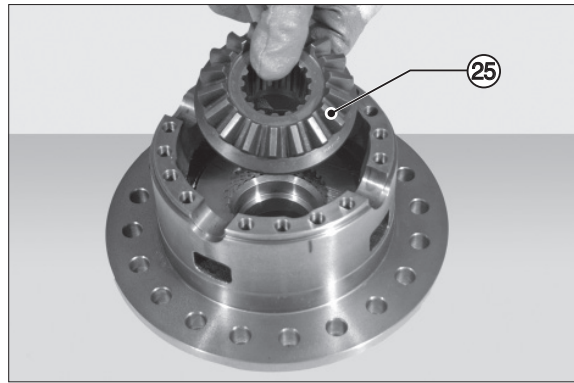

7409FAX147

(4) Install the planetary gears (26) and spherical shoulder washers (25) onto the bolts (24).
Install the planetary set.

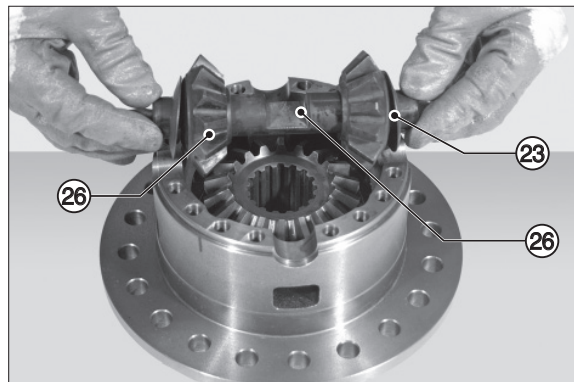

7409FAX148

(5) Install crown wheel (25).

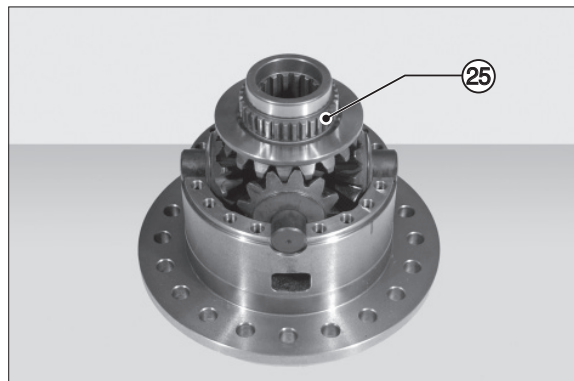

7409FAX149

(6) Fit increased disc (18), clutch pack (29) and shims (6) onto the crown wheel (25).
Fit the upper half box (26) and make sure that the match marks line up.

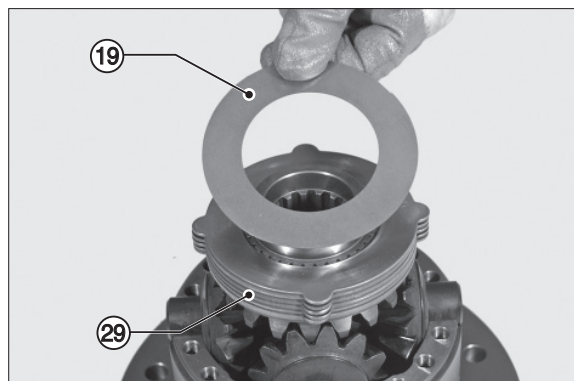

7409FAX150

(7) Lock the half box with screws (27) coated with loctite 242.

- ※ 1. The match marks on the two half-boxes must correspond.
- 2. Use only new screws.

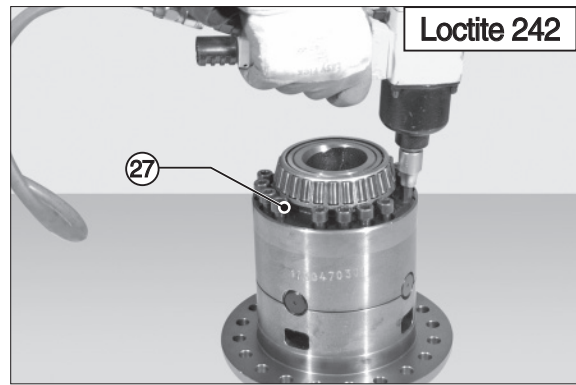

7409FAX151

(8) Fit the complete differential unit in a vice and tighten the screws (27) holding the two half boxes together to a torque of 7.29~8.0 kgf · m (52.7~57.9 lbf · ft).

- ※ Tighten screws using the alternate and criss-cross method.



7409FAX152

(9) Mount the gear ring (18) and fasten it to the differential box with screws (16).

- ※ Use only new screws.

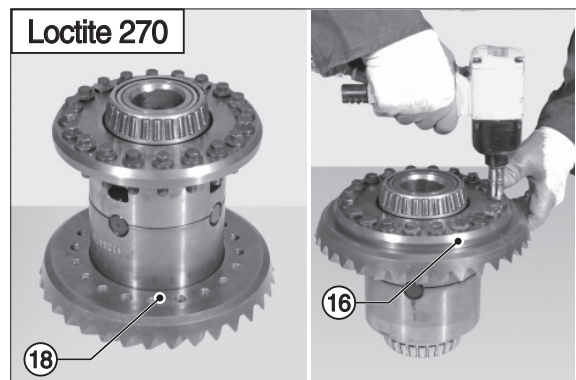

7409FAX153

(10) Lock the gear ring (6) by tightening the screws (4) to a torque of 14.2~15.7 kgf · m (103~114 lbf · ft)

- ※ Use the alternate and criss-cross tightening method.



7409FAX154

Installation of the differential unit

- (11) Position the differential unit under a press and, using a driver with an adequate diameter, install the first bearing (4).

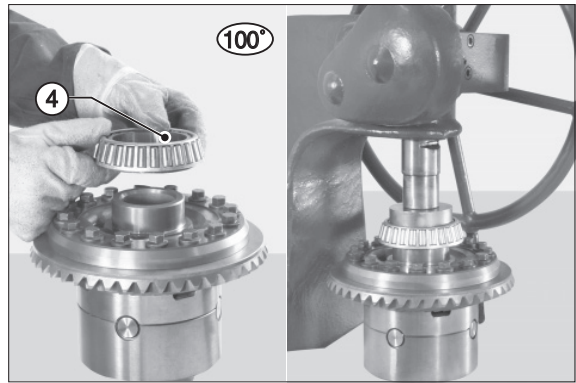

- (12) Turn the unit upside down and install the second bearing (4).

- ※ Pay particular attention; position a shim with adequate diameter in order to engage the internal ring of bearing without engaging the cage.

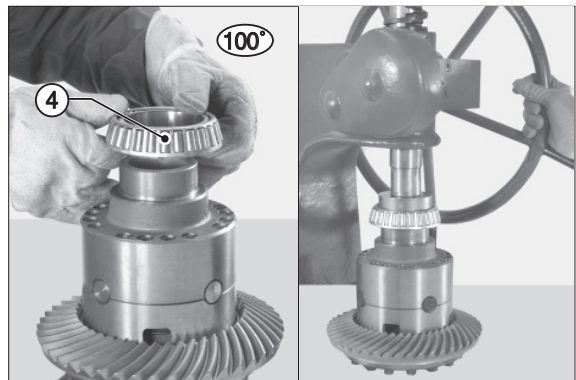

(13) Only if bearings are replaced

- Insert the thrust blocks of the bearings (4) into the intermediate covers (7).

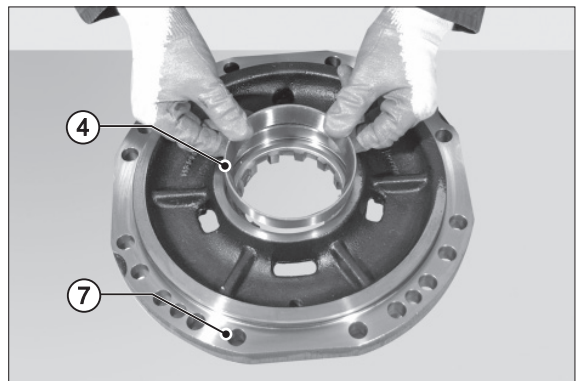

- ※ Thoroughly check the state of the O-ring (9).

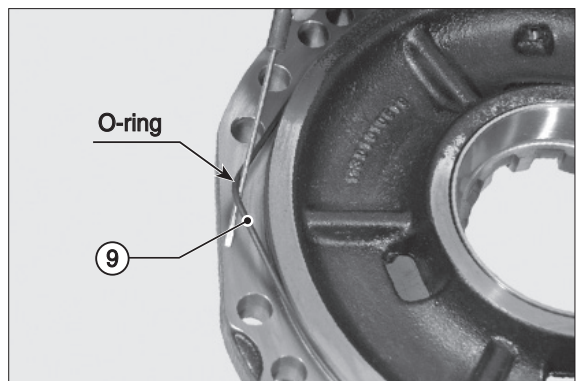

- (14) Fit the intermediate cover (7) on opposite side of ring gears : lock cover with screws (6) coated with loctite 242.

Tighten screws to a torque of 13.2~14.6 kgf · m (95.5~106 lbf · ft).

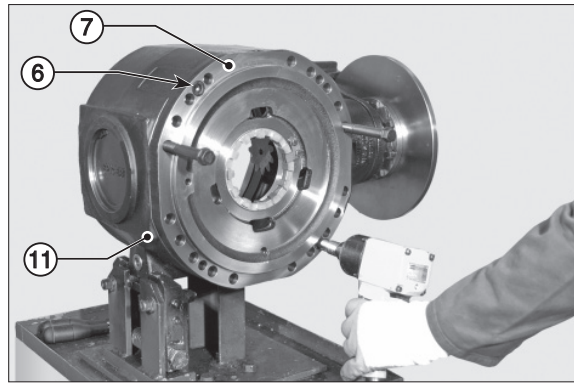

- (15) Position the differential unit (10) in the central body with the help of a bar and fit the middle cover.

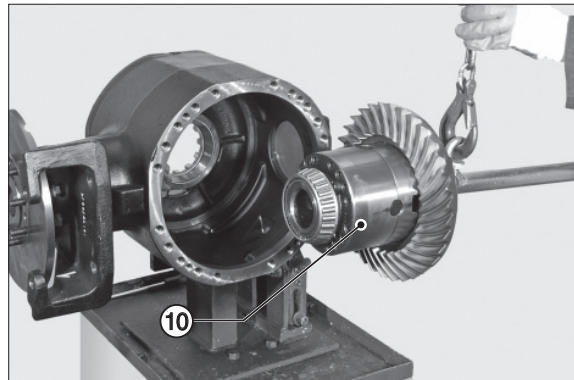

- (16) Tighten the two safety screws "C" into the main body (11) and install the intermediate cover (7).

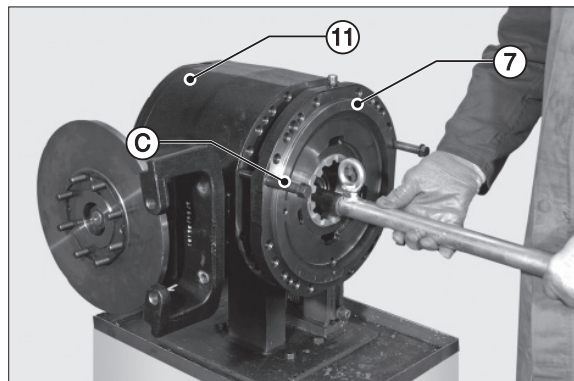

- (17) Tighten screws (6) to a torque of 13.2~14.6 kgf · m (95.5~106 lbf · ft).

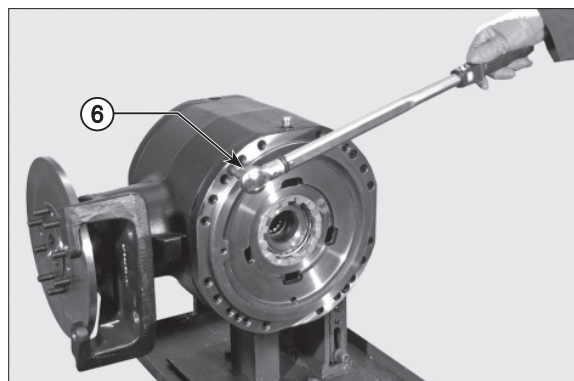

(18) Only if ring nuts have been removed

Tighten the ring nut (3) on gear ring side until clearances between pinion and gear ring are zeroed. Then, loosen by about 1/4 turn.

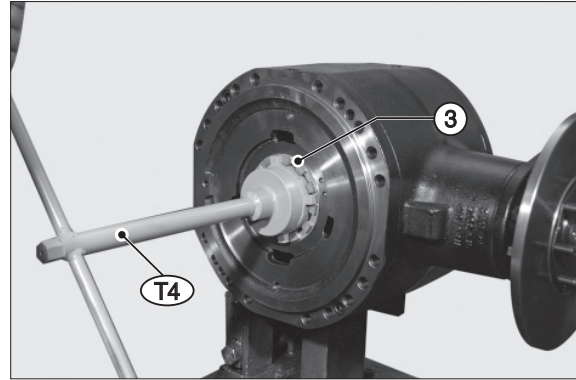

7409FAX163

(19) Only if ring nuts have been removed.

Preload bearings with ring nut (26) on non-gear ring side in order to increase the torque of the pinion.

- ※ In the case of used bearings, check thrust torque; in the case of new bearings, check continuous torque.

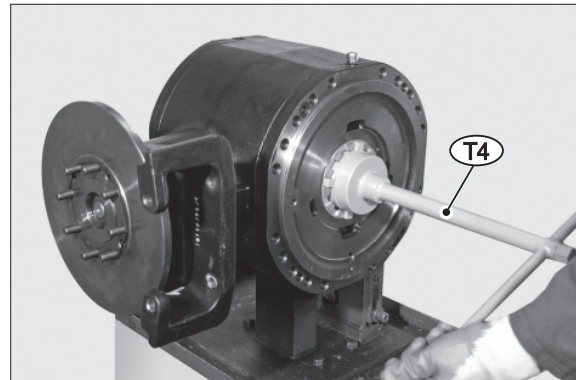

7409FAX164

(20) Apply torque meter TM to pinion nut and check that torque will increase by 20-40 Ncm as a result of differential bearing preload.

Example :

- Pinion torque : 12.2~18.4 kgf · cm
- Pinion + differential torque :
14.3~19.4 kgf · cm

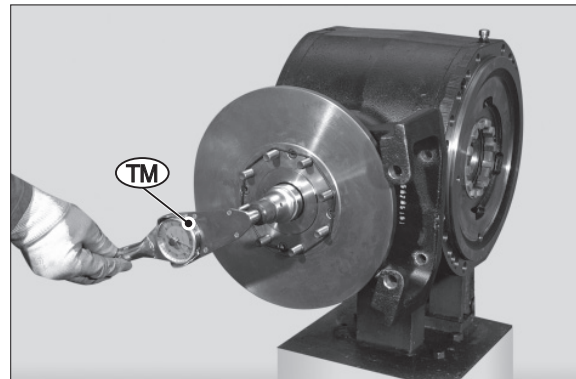

7409FAX165

(21) Introduce a comparator "A" with long tracer through the hole provided for the cap. Position the tracer on the side of a tooth of the gear ring, approximately 5 mm from the outer rim; preload by about 1 mm and zero the comparator.

As you hold the pinion in position, move the gear ring manually in both directions to check clearance between pinion and gear ring.

Standard clearance : 0.25 - 0.35 mm

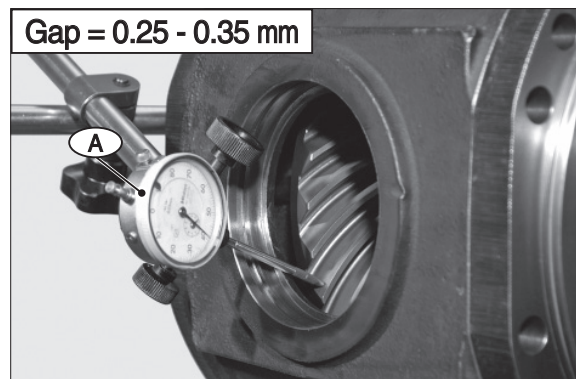

7409FAX166

(22) Adjusting clearance between pinion and gear ring.

To INCREASE : loosen the ring nut on gear ring side and tighten the ring nut on non-gear ring side by the same measure.

To DECREASE : perform the same operations inversely.

To rotate ring nuts, use special wrench T4.

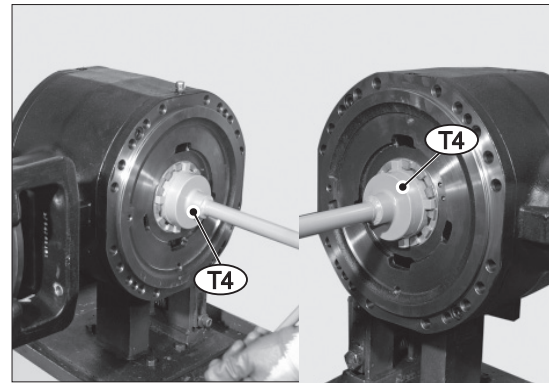

7409FAX167

(23) Install in correct position the safety plate (2).

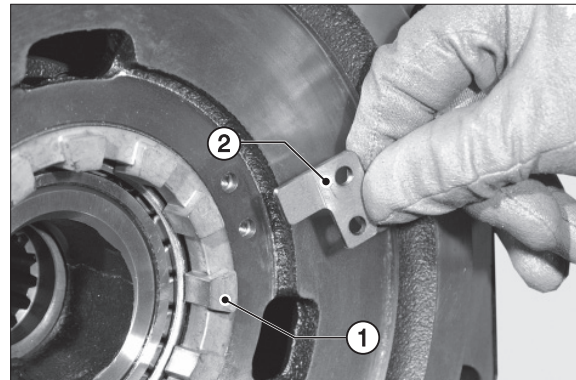

7409FAX168

(24) Engage screw (1) in the slot next to the holes provided for the check screws.

Coat screws with loctite 270 and tighten to a torque of 1.12 kgf · m (8.11 lbf · ft).

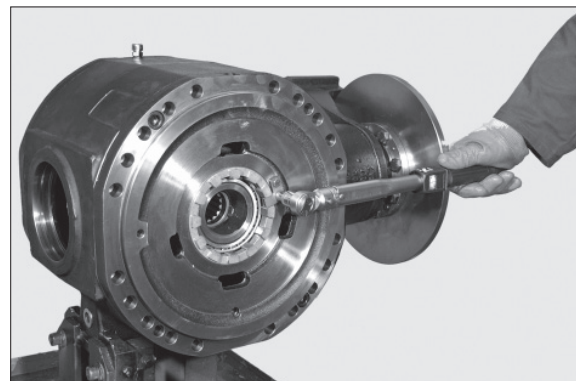

7409FAX169

(25) Using a driver, fit the cap (14) and position it in its seat with the snap ring (13).

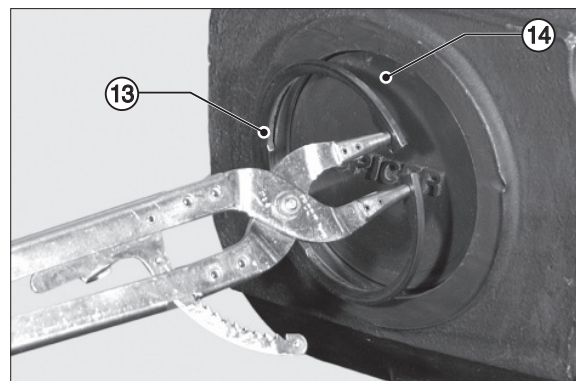

7409FAX170

(26) Check that the positioning of the sealing ring on the arm is intact; install the complete arm. Lock it into position using two facing screws and washers.

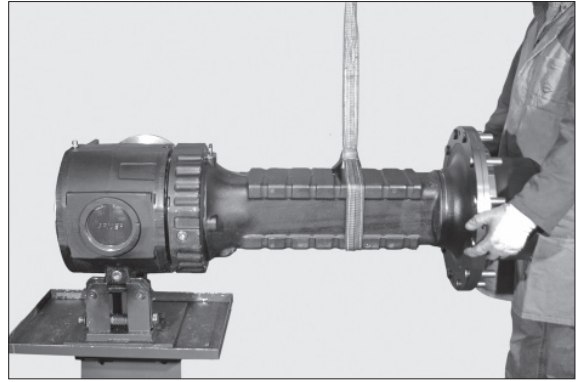

7409FAX171

(27) Temporarily lock the arm with screws previously coated with loctite 242; tighten lightly to make the unit touch the main body.

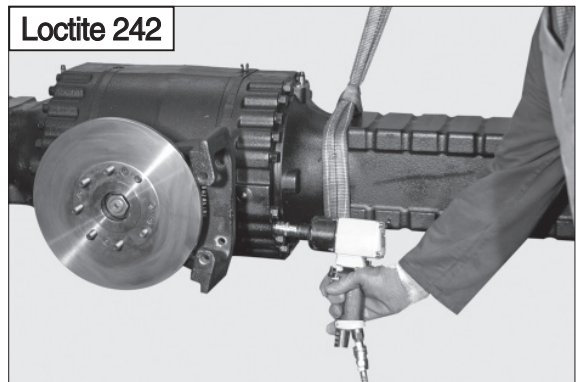

7409FAX172

(28) Check the flatness of the arms, using tool T11; then lock the arms into their final position, using screws adequately coated with loctite 242.

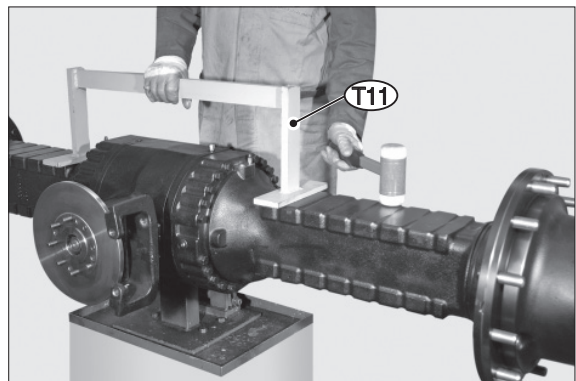

7409FAX173

(29) Cross tighten the nuts in two stages.

- Torque wrench setting :
30.4 kgf · m (219 lbf · ft)

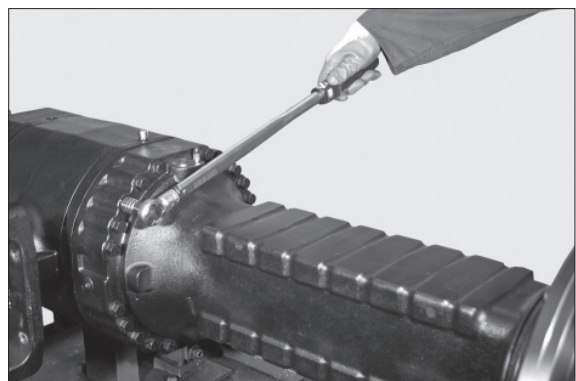

7409FAX174

9) HOW TO REMOVE THE BEVEL PINION WITH SUPPORT BRAKING DISK

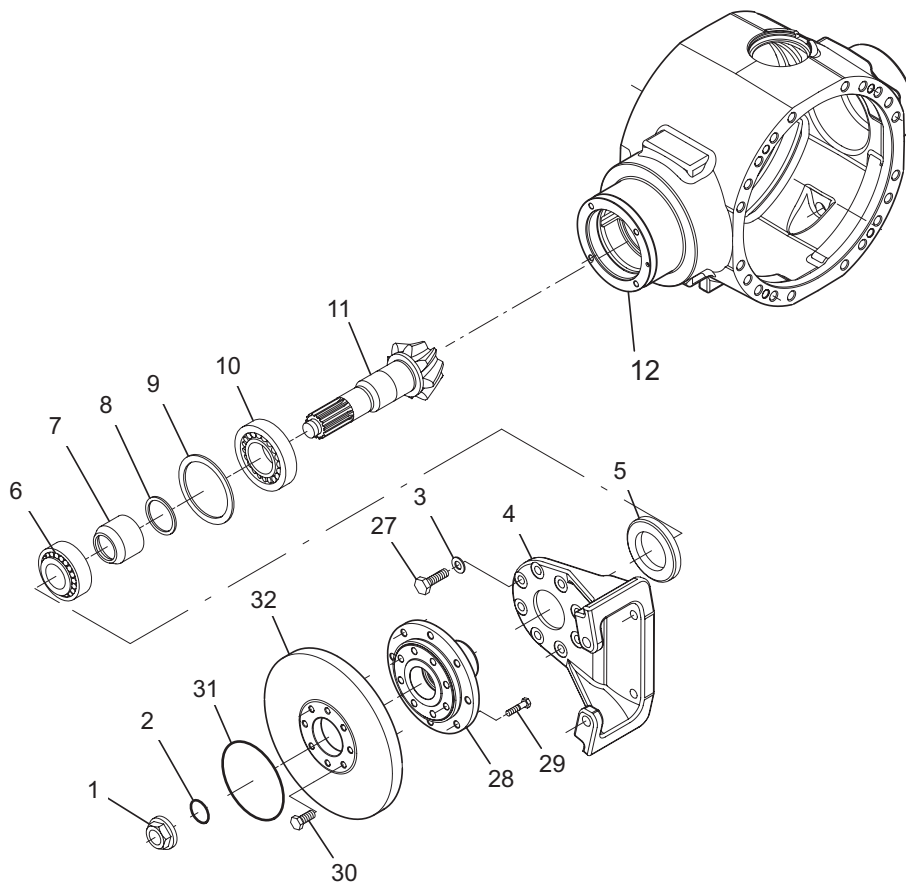

7409FAX175

- (1) Remove the intermediate cover and the whole differential unit.
For details, see HOW TO REMOVE THE DIFFERENTIAL UNIT.

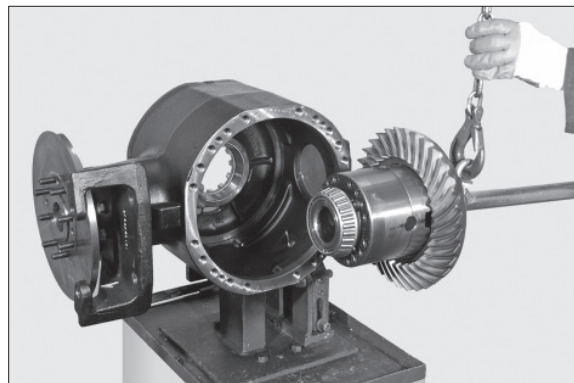

7409FAX176

- (2) Remove the snap ring.

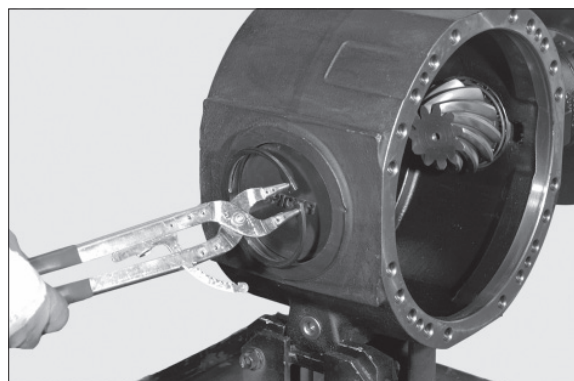

7409FAX177

(3) Remove the cap.

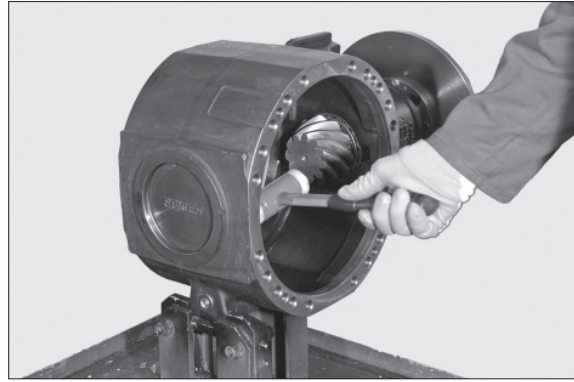

7409FAX178

(4) Draw out the screws (30) and remove the disk (32).

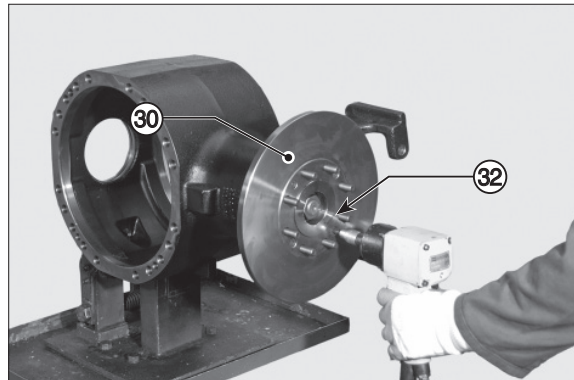

7409FAX179

(5) Position tool T13, so as to avoid pinion rotation.
Unloose and remove the nut (1); also remove the O-ring (2).

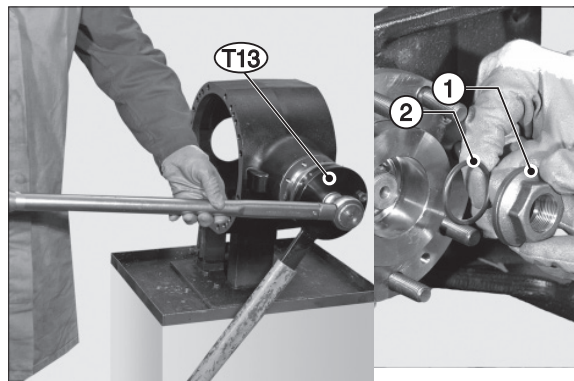

7409FAX180

(6) Remove the flange (28).

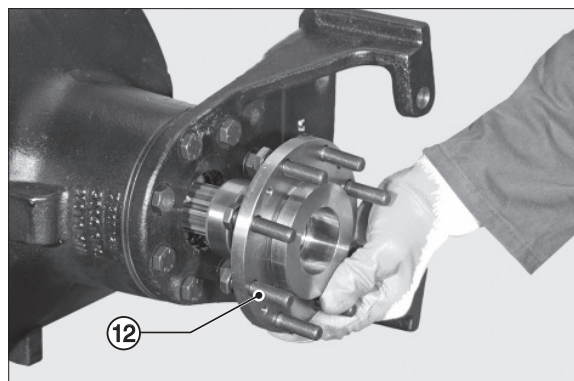

7409FAX181

(7) Remove the retainer screws (23) and relative washers (3).

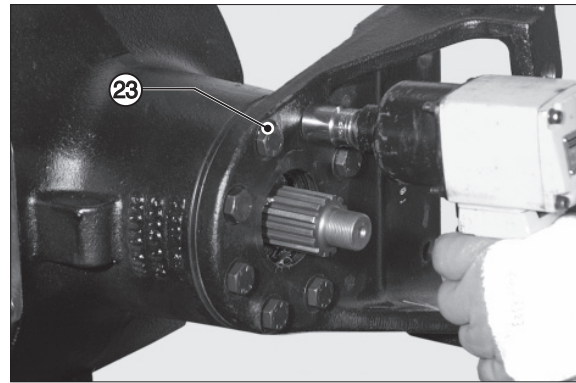

7409FAX182

(8) Remove the brake support (4).

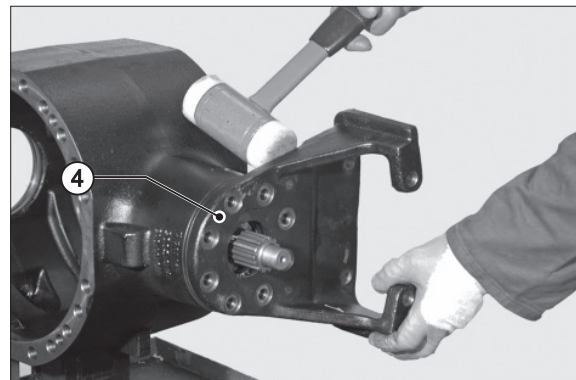

7409FAX183

(9) Remove the sealing ring (5).

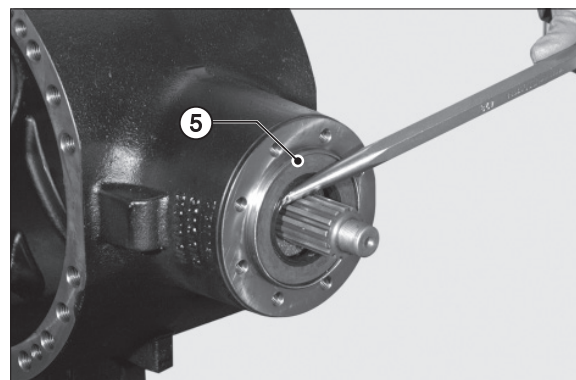

7409FAX184

(10) Extract the pinion (11) complete with the internal bearing cone (10), the distance piece (7) and shims (8).

※ The bearing cups of the bearing cones remain in the central body.

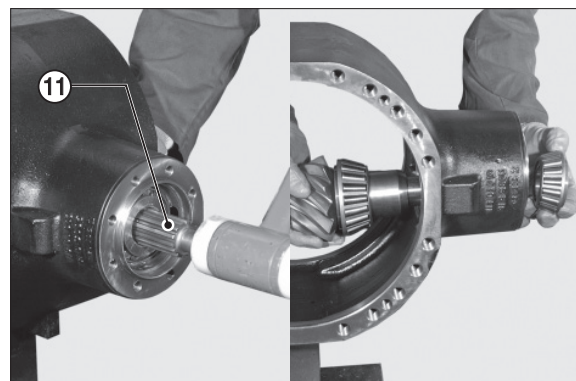

7409FAX185

(11) Refer and keep to the positions marked during disassembly.

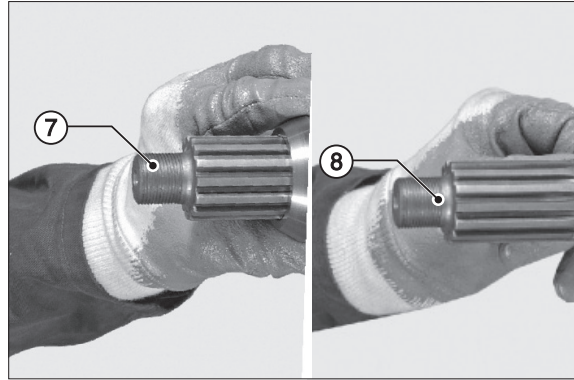

7409FAX186

(12) Using a puller and a press, remove the inner bearing cone (10) from the pinion (11).

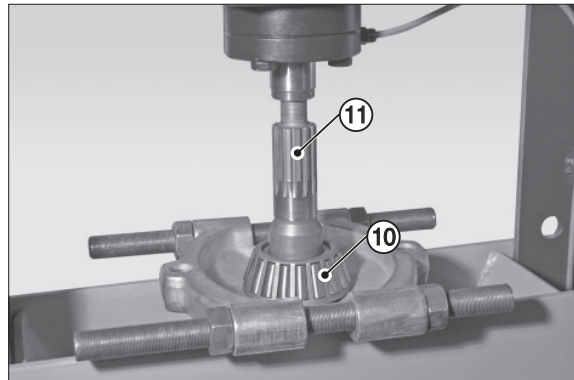

7409FAX187

(13) Remove the bearing cup of the tail bearing cone (6).

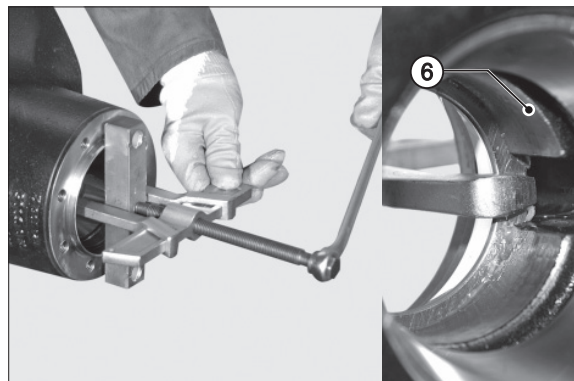

7409FAX188

(14) Remove the bearing cup of the internal bearing cone (10) as well as the shim washers (8).

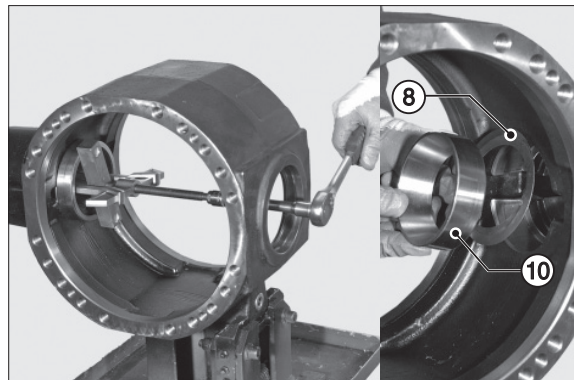

7409FAX189

10) HOW TO INSTALL AND ADJUST THE BEVEL PINION WITH SUPPORT BRAKING DISK

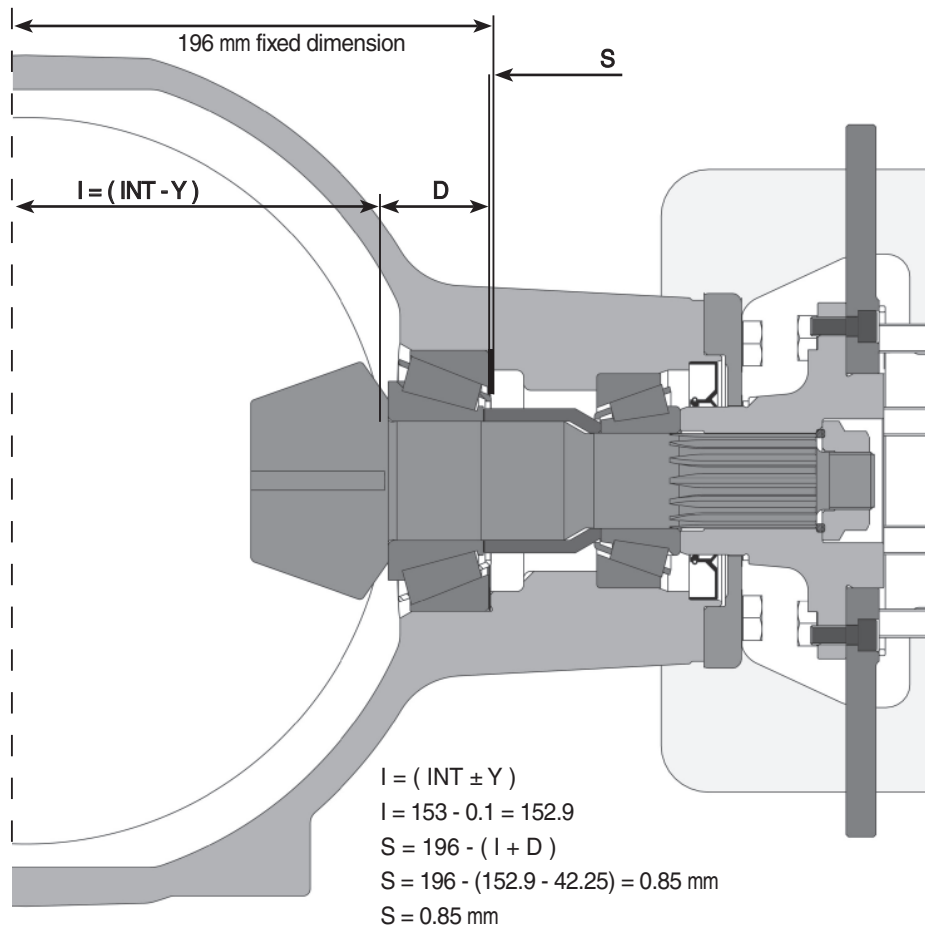

7409FAX190

- (1) Reset a centesimal digital depth gauge on a calibrated block (whose known thickness is 20 mm).

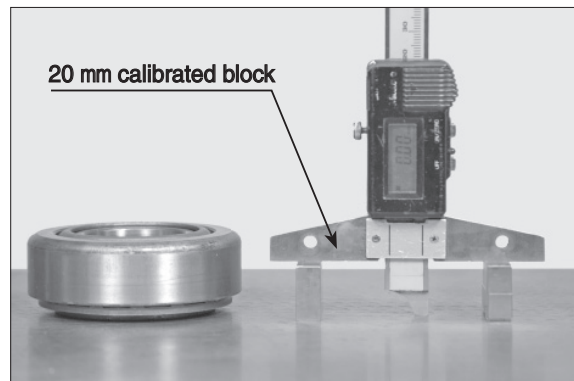

7409FAX191

- (2) With a calibrated block on a faceplate, allow the bearing cone to set by rotating them in both directions and by applying a vertical thrust position the calibrated block on the external bearing cups. Check overall thickness of bearing.

$$D = 42.25 \text{ mm}$$

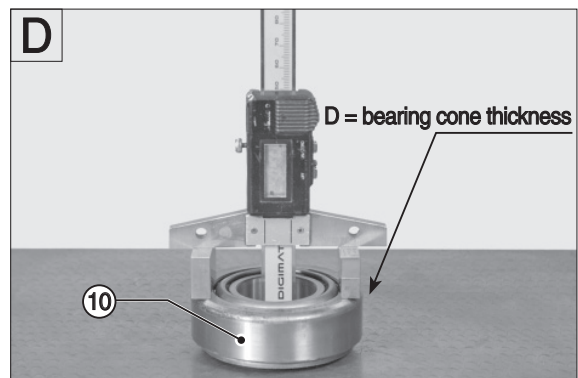

7409FAX192

- (3) Check nominal dimension "INT" as marked on the pinion.

Add up to or subtract from "INT" the variation indicated as "Y" to obtain the actual center distance "I".

Example :

$$I = (INT - Y) = 153 - 0.1 = 152.9 \text{ mm}$$

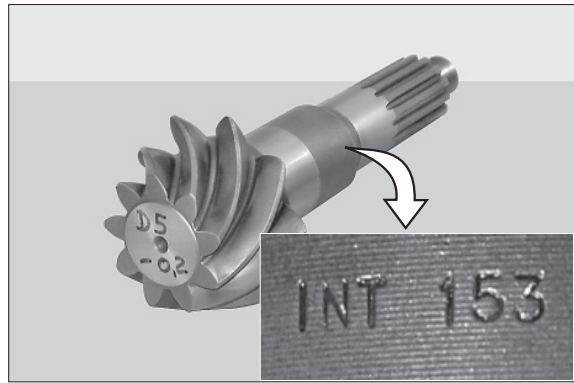

7409FAX193

- (4) Calculate shims "S" for insertion under the bearing cup of the inner bearing cone using the following formula :

$$S = 196 - (I + D)$$

where: 196 = fixed dimension

I = actual pinion center distance

D = Total bearing thickness;

Example :

$$S = 196 - (152.9 + 42.25) = 0.85 \text{ mm}$$

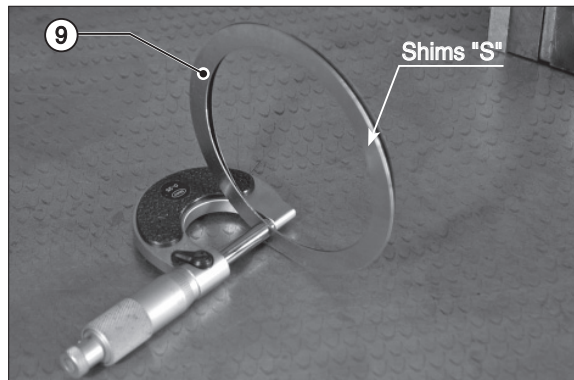

7409FAX194

- (5) Using special tool T6.
Partially insert the bearing cup of the bearing cones (6) and (10) and shims (9).

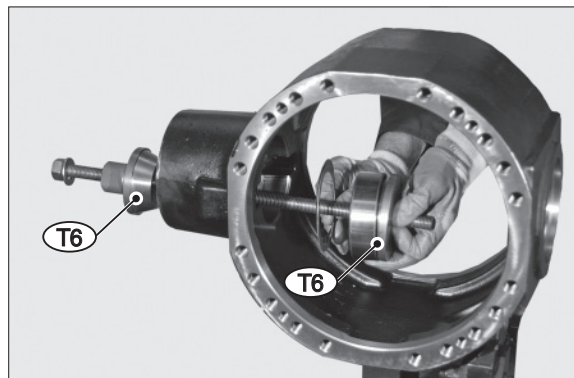

7409FAX195

- (6) Connect the tension rod to the press and move the bearing cup of bearing cones (6) and (10) into the seats.
Disconnect the press and remove the tension rod.

※ Before starting the next stage, make sure that the bearing cup has been completely inserted into its seat.

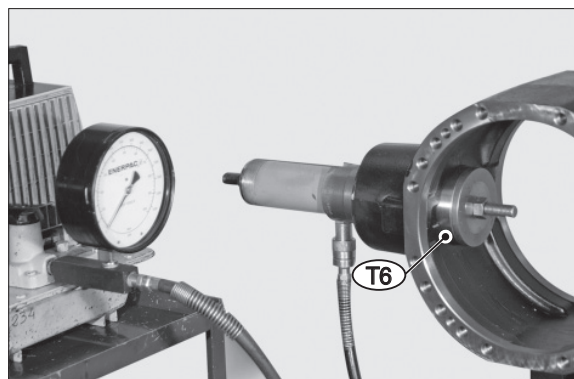

7409FAX196

Calculation pinion bearings rolling torque

- (7) Introduce tool T5 complete with bearings (6) and (10) into the central housing; tighten by hand until to eliminate the axial gap.

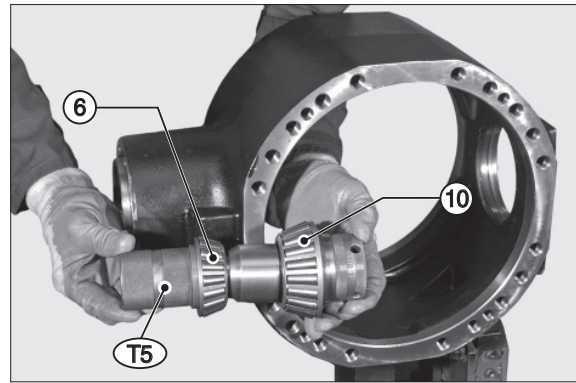

7409FAX197

- (8) Introduce the tracer of a dept comparator 'DDG' into either side hole of tool T5. Reset the comparator with a preload of about 3 mm.

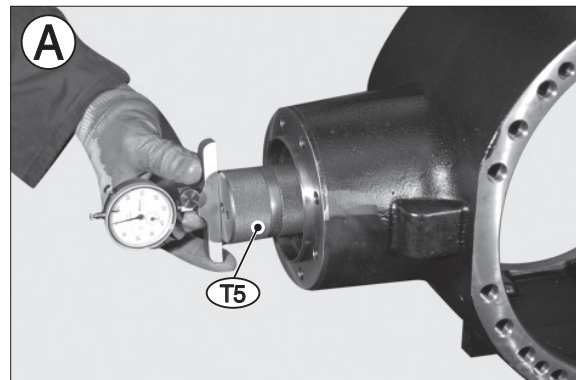

7409FAX198

- (9) Remove the comparator and take out tool and bearing cone kits from the main body. Reinstall every part, also introducing a distance piece (7) between bearing cones (10) and (6). Tighten the entire pack by hand.

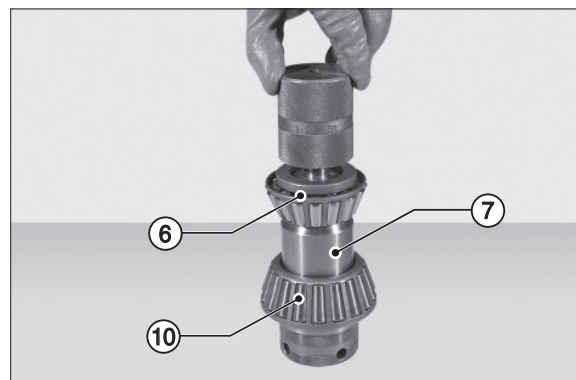

7409FAX199

- (10) Introduce depth comparator "DDG" in tool T5 and measure deviation "H" from the previous reset.

Example :

$$H = A - B = 1.8 \text{ mm}$$

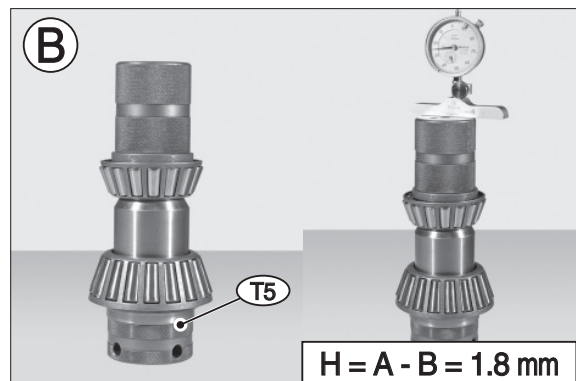

7409FAX200

- (11) Deviation “H” must be added to a set value of **0.10 mm** to make up the pack of shims “S1” (8) for insertion between pinion (6) and distance piece (7). Dimension “S1” must be rounded off to the higher 5/100.

Example :

$$S1 = H + X = 1.8 + 0.1 = 1.9 \text{ mm}$$

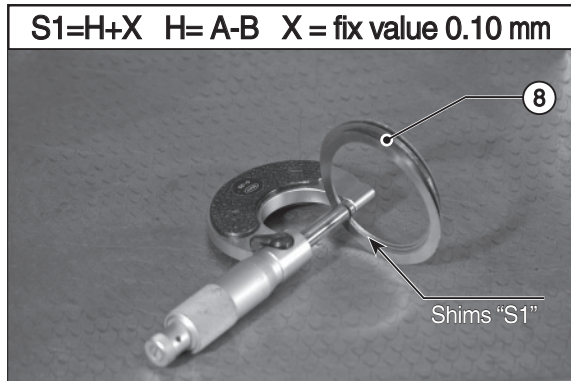

- (12) Position the internal bearing (10) and the pinion (11) under a press; force the bearing onto the pinion.

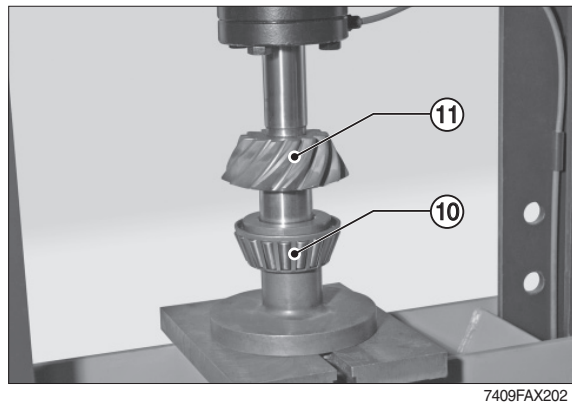

- (13) Insert the external bearing (6) in the central body in order to complete the pack arranged as in the figure.

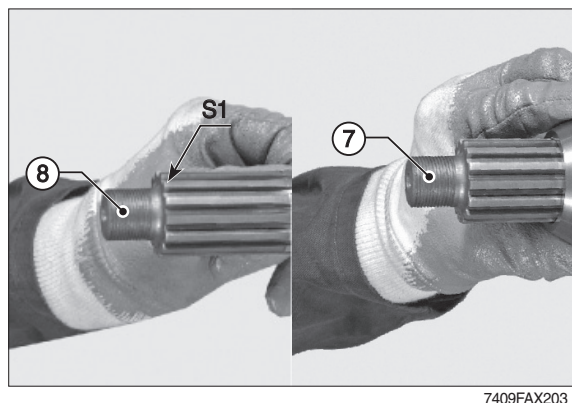

- (14) Fit the pinion (11), shim “S1” (9) and distance piece (7) in the main body (12).

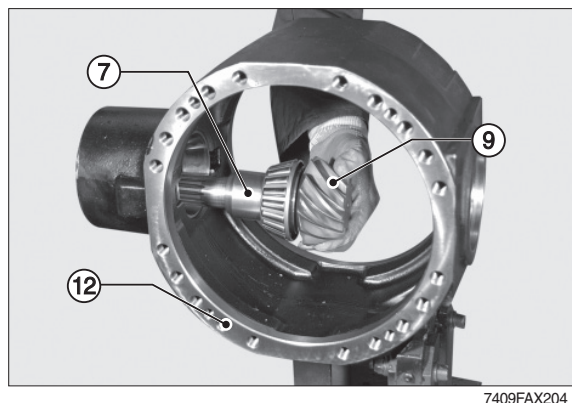

(15) Heat the external bearing cone (6) to a temperature of about 100°C and fit it on to the pinion (11) so as to complete the pack as shown in the figure.

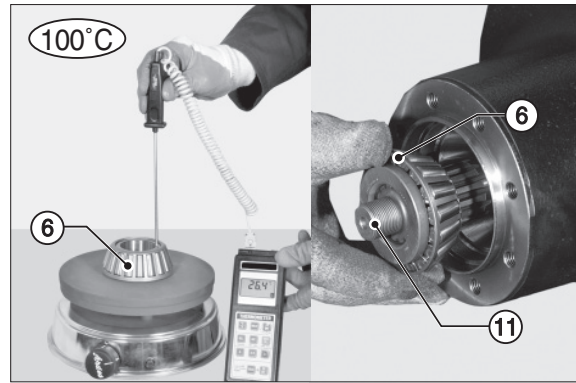

7409FAX205

(16) Install the flange (28) onto the pinion (11) without sealing ring.

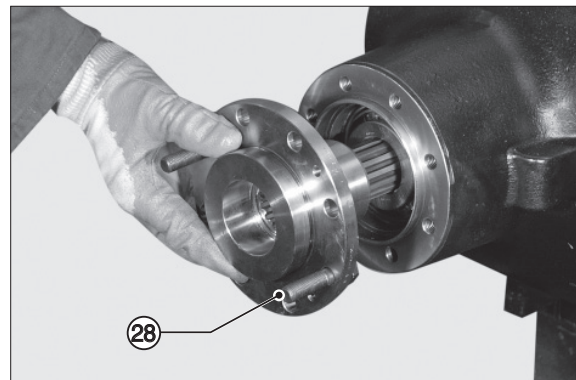

7409FAX206

(17) Apply wrench to the ring nut (1) and special tool T5 to the pinion (11). Lock the wrench T5 and rotate the pinion using a dynamometric wrench, up to a minimum required torque setting of 89.7~112 kgf · m (649~810 lbf · ft).



7409FAX207

(18) Apply onto the pinion (11) the bar-hold and with the help of a torque meter, check the torque of the pinion (11).

· Torque : 12.2~18.4 kgf · cm

※ If torque exceeds the maximum value, then the size of shim “S1” (9) between the bearing cone (10) and the distance piece (7) needs to be increased.

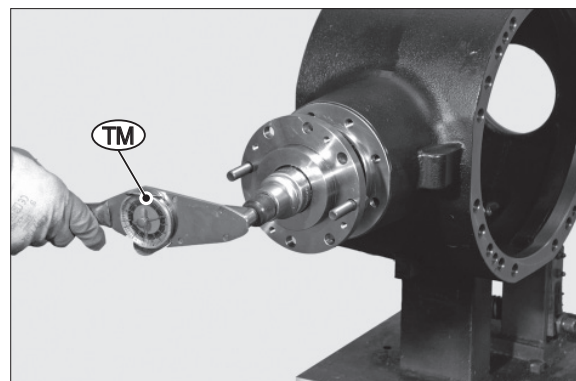

7409FAX208

(19) If torque does not reach the set value, increase the torque setting of the ring nut (3) in different stages to obtain a maximum value of 89.7~112 kgf · m (649~810 lbf · ft).

※ If torque does not reach the minimum value, then the size of shim “S1” (9) needs to be reduced.

※ When calculating the increase or decrease in size of shim “S1”, bear in mind that a variation of shim (9) of 0.01 mm corresponds to a variation of 6.12 kgf · cm in the torque of the pinion (11).

(20) Remove nut (1) and flange (28)

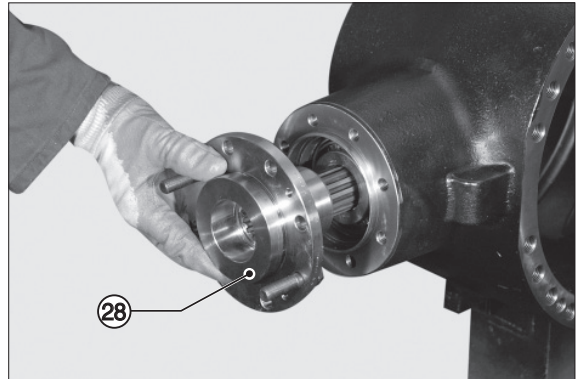

7409FAX209

(21) Apply Arexons rubber cement to the outer surface of the new seal ring (5) and fit ring in the main body using driver T7.

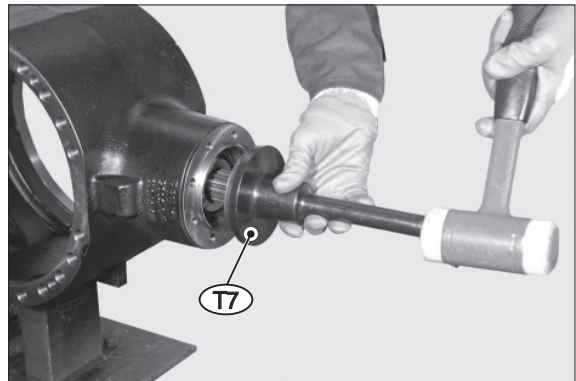

7409FAX210

(22) Lubricate the coupling surfaces and position the brake support (4).

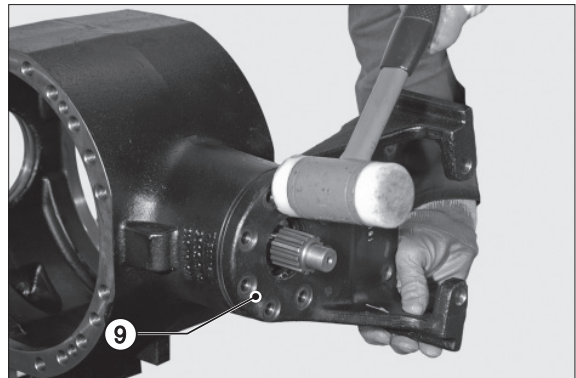

7409FAX211

(23) Apply loctite 242 to the screws (13) and tighten using the crisscross method.

- Torque wrench setting :
 $11.8 \pm 13.1 \text{ kgf} \cdot \text{m}$ ($85.3 \pm 94.4 \text{ lbf} \cdot \text{ft}$)

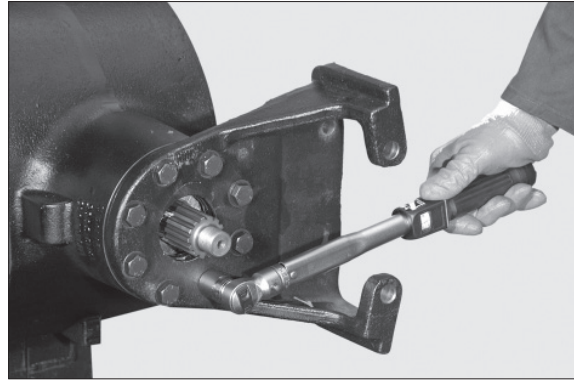

7409FAX212

(24) Oil seal ring lips and install flange (28).
Mount O-ring (2) and apply loctite 242 to pinion tang; tighten nut (1).

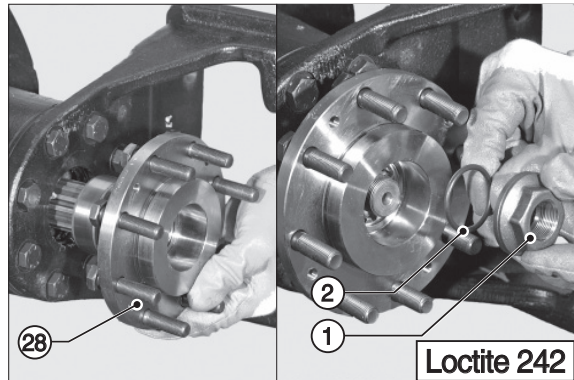

7409FAX213

(25) Apply wrench to the ring nut (1) and special tool T5 to the pinion (11).
Lock the wrench T5 and rotate the pinion using a dynamometric wrench, up to a minimum required torque setting of $89.7 \sim 112 \text{ kgf} \cdot \text{m}$ ($649 \sim 810 \text{ lbf} \cdot \text{ft}$).

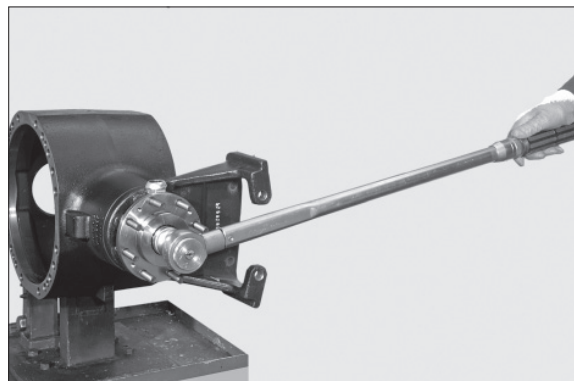

7409FAX214

(26) Install disk (3) and keep it into position with screws (19) and nuts (4).

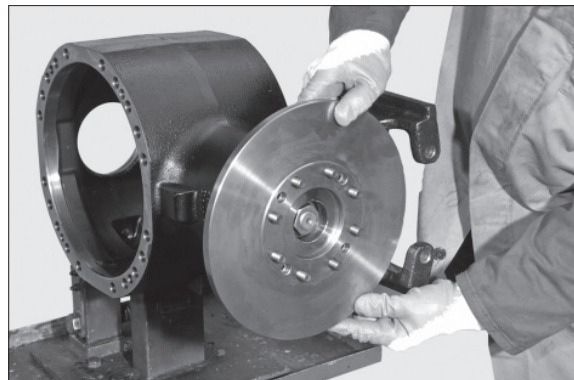

7409FAX215

(27) Tighten using a dynamometric wrench to a tightening torque of $13.1 \pm 14.5 \text{ kgf} \cdot \text{m}$ ($94.8 \pm 105 \text{ lbf} \cdot \text{ft}$).

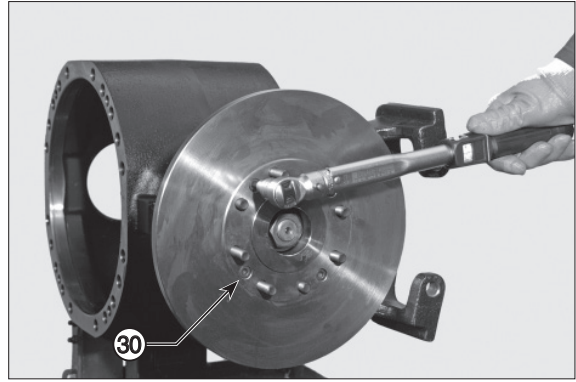

7409FAX216

(28) Using a driver, fit the cap and position it in its seat with the snap ring.

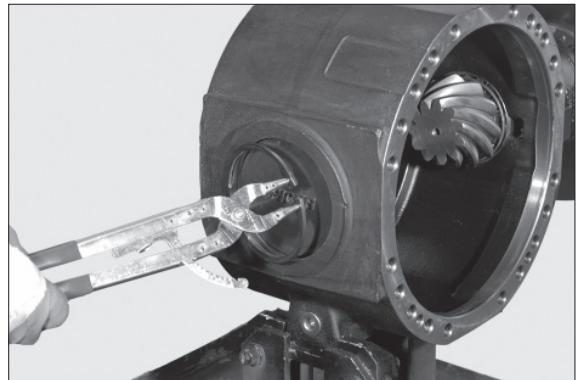

7409FAX217

(29) Reinstall the differential unit and the intermediate cover.

※ If the crown and pinion has been replaced, reinstate clearances.

For details, see HOW TO ASSEMBLE AND ADJUST THE DIFFERENTIAL UNIT.

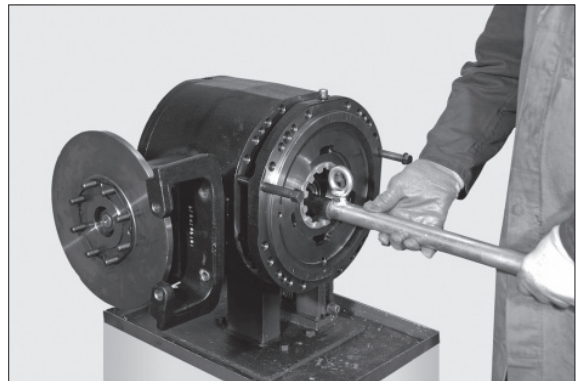

7409FAX218

11) HOW TO REMOVE THE FLANGED BEVEL PINION

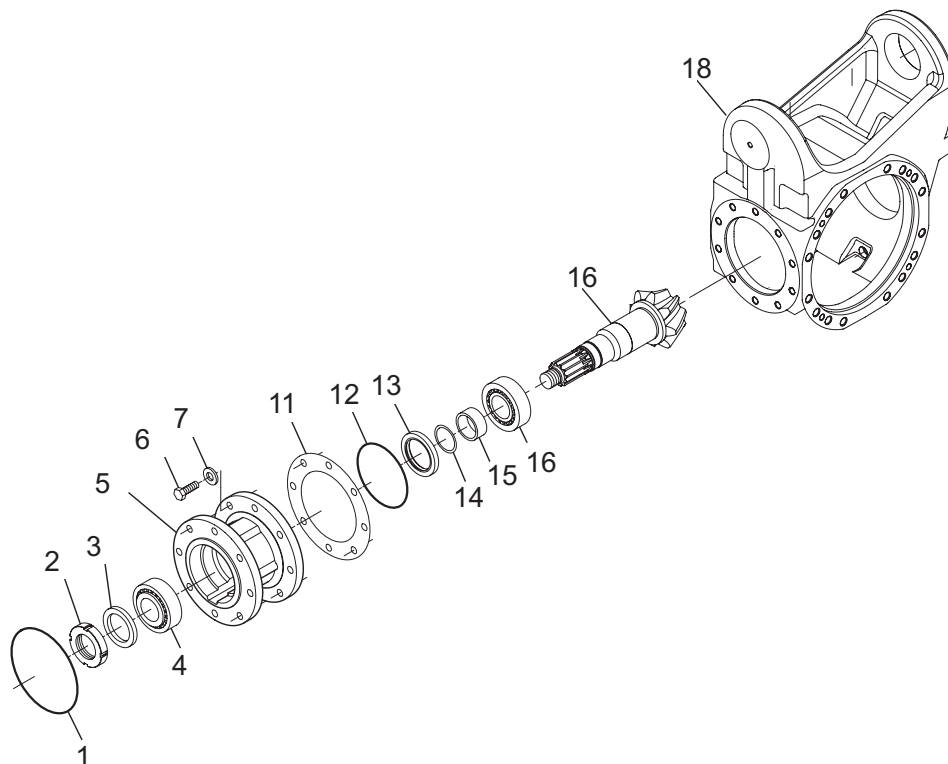

7409FAX219

- (1) Remove the retainer screws (6) and relative washers (7).

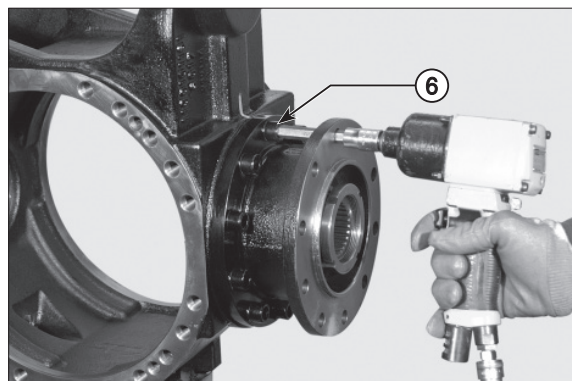

7409FAX220

- (2) Remove shims (11) and pinion support (5). Refer and keep to the positions marked during disassembly.

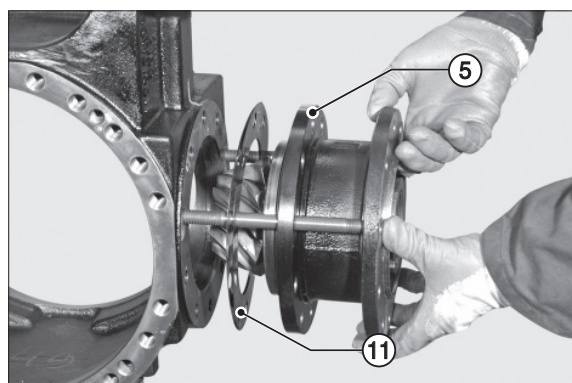

7409FAX221

- (3) Stop wrench and rotate the pinion so as to release and remove the ring nut (2).

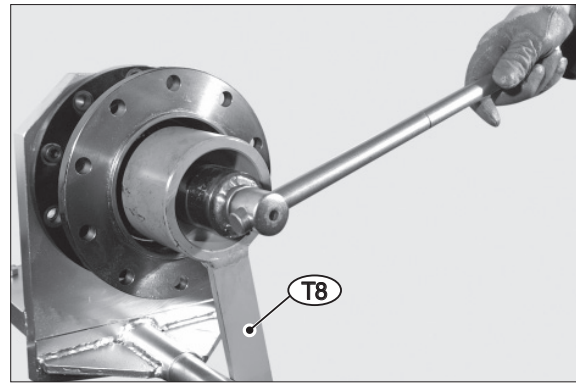

7409FAX222

- (4) Remove pinion ring nut (2).

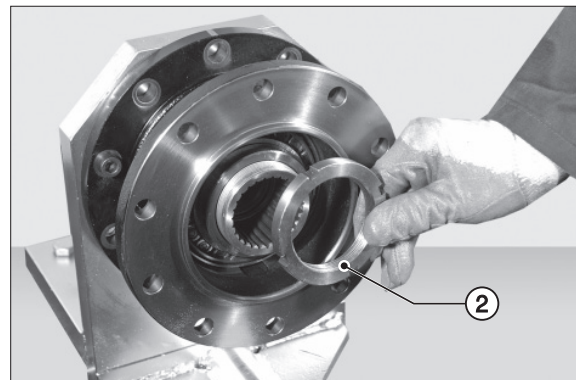

7409FAX223

- (5) Position the cover under a press, extract the pinion (18) complete with the internal bearing (16), the distance piece (15) and shims (14).

※ The thrust blocks of the bearings remain in the central body (5).

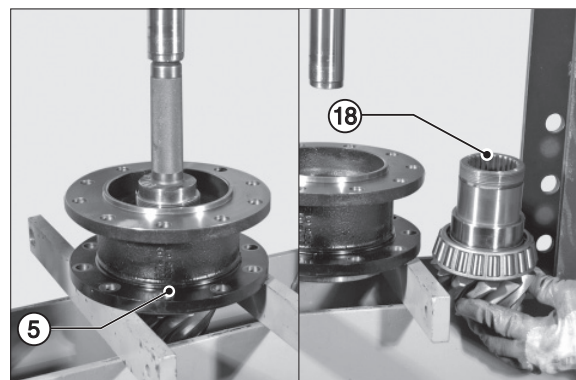

7409FAX224

- (6) Remove sealing ring (13) and bearing (4).

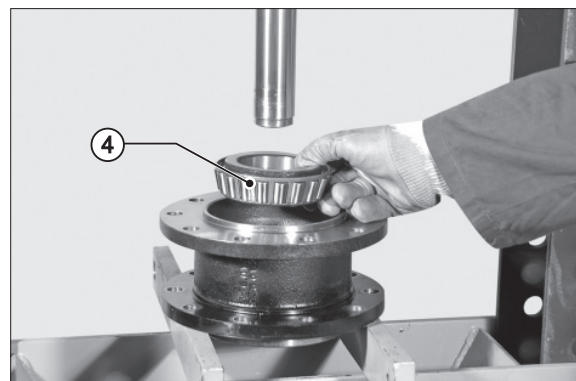

7409FAX225

(7) Remove spacer (15) and shims (14).

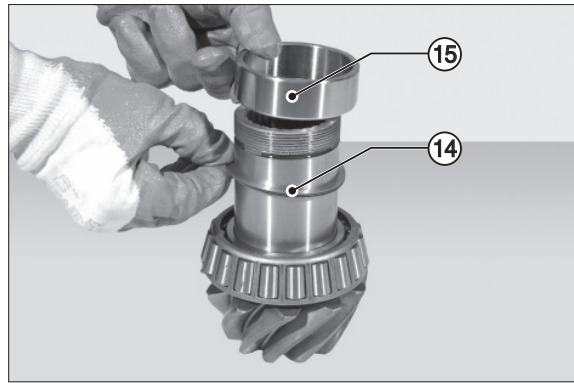

7409FAX226

(8) Position the pinion (18) under a press, remove the bearing (16).

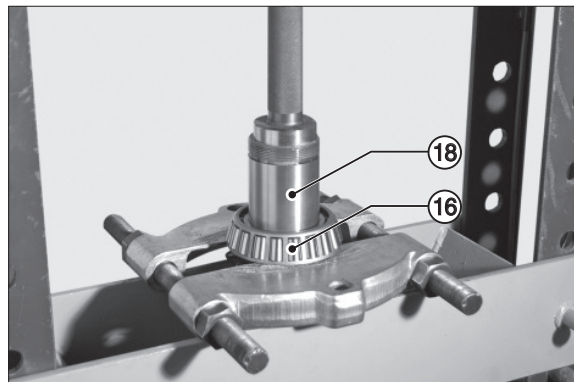

7409FAX227

(9) With the help of an extractor, remove the thrust blocks (4)(16).

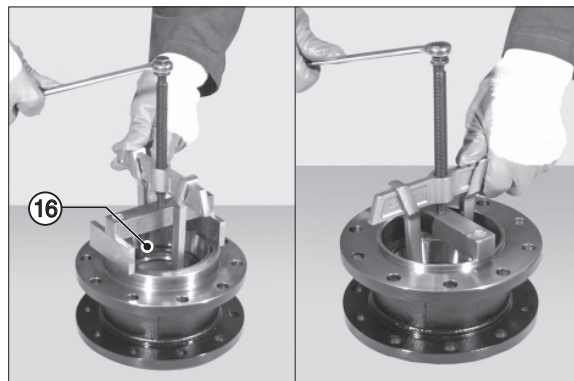

7409FAX228

(10) Remove sealing ring (13).

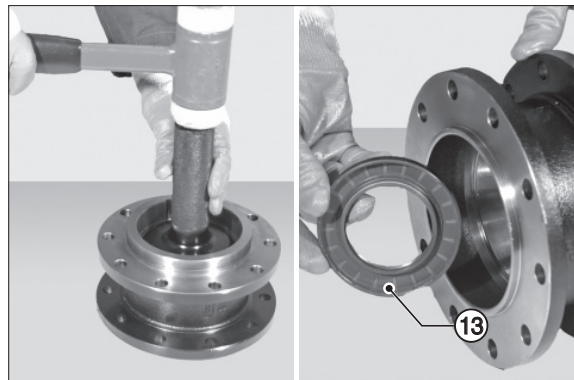

7409FAX229

12) HOW TO INSTALL AND ADJUST THE FLANGED BEVEL PINION

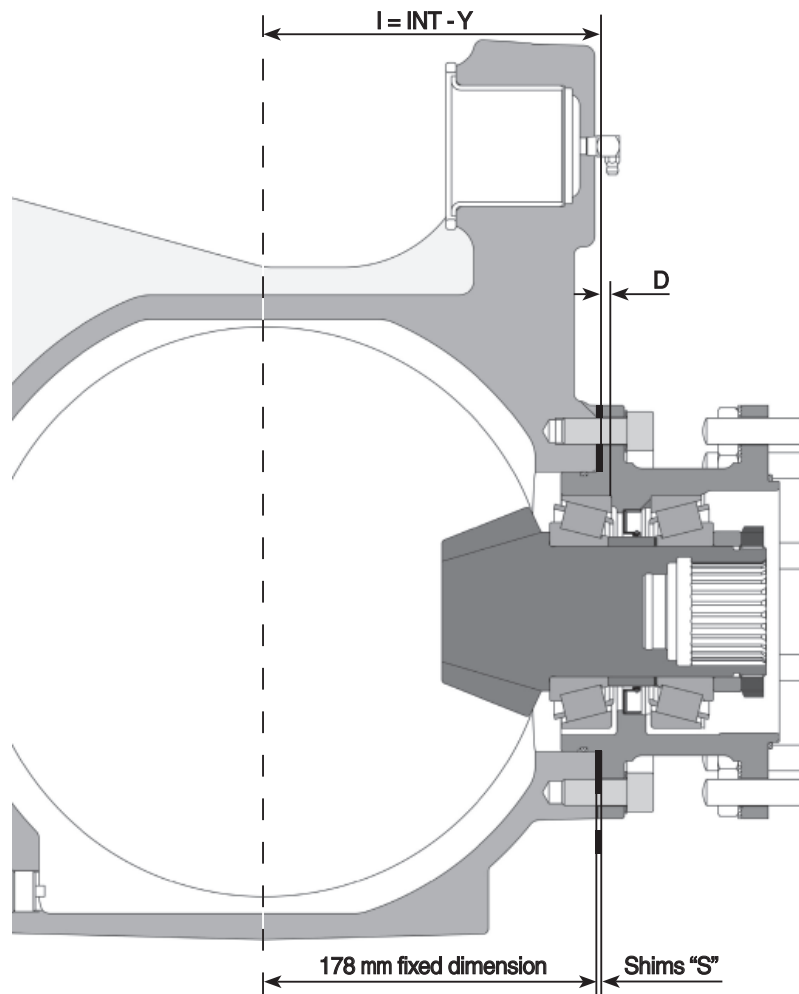

$$I = (INT \pm Y)$$

$$I = 153 - 0.1 = 152.9$$

$$S = 178 - (I + D)$$

$$S = 178 - (152.9 - 25.8) = 0.7\text{mm}$$

$$S = 0.7\text{mm}$$

7409FAX230

- (1) Lubricate the outer surface of the new sealing ring (13) and fit it onto the cover (5) using tool T9.

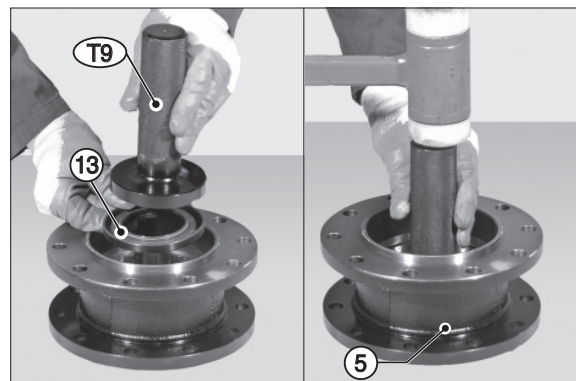

7409FAX231

- (2) Using tool T10, insert the thrust blocks of bearing (4)(16).

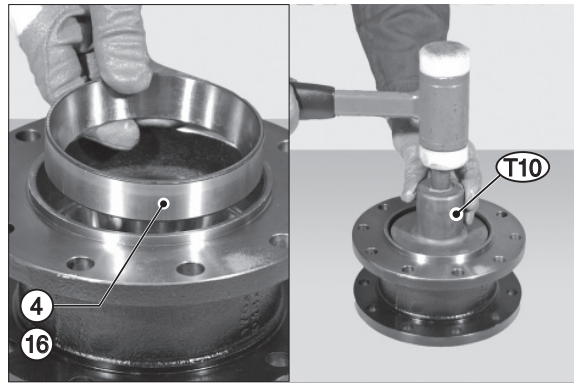

7409FAX232

- (3) Reset the digital dept gauge on pinion bearings (4)(16) and pinion spacer arranged (15) as in the figure.

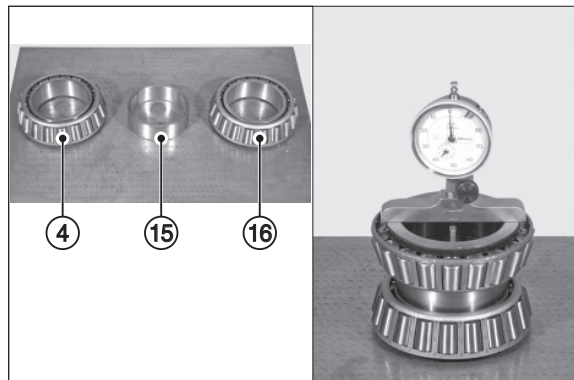

7409FAX233

- (4) Using a surface plate, position the pinion support (5) on the outer bearing (16) and then insert the outer bearing (4) in the pinion support (5).

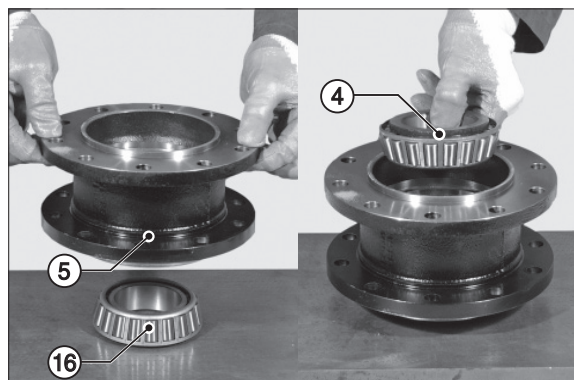

7409FAX234

- (5) Arrange accurately the pinion bearings.

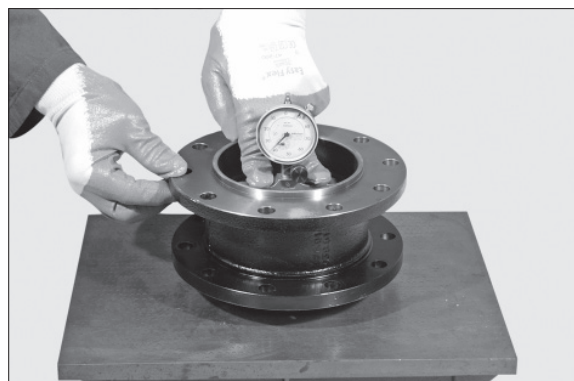

7409FAX235

- (6) Insert depth comparator “DDG” into pinion support (5) and measure variation “H” in relation to the zero setting performed back at point C.

$H = 1.7 \text{ mm}$

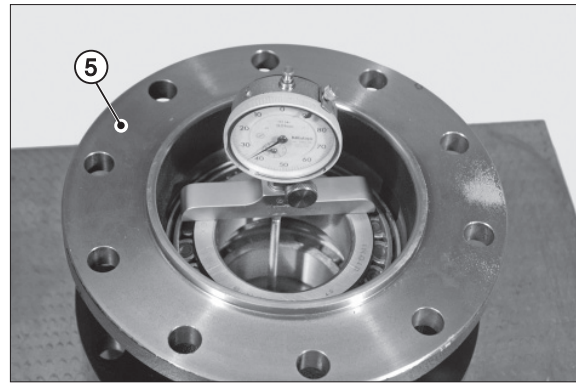

7409FAX236

- (7) Heat the inner bearing (16) to about 100 °C and fit it to the pinion (18).

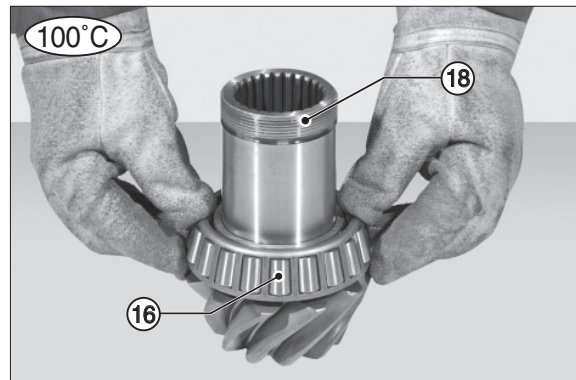

7409FAX237

- (8) Deviation “H” must be added to a set value of 0.10 mm to make up the pack of shims “S1” (14) for insertion between inner bearing cone (4) and distance piece (15).

Dimension “S1” must be rounded off to the higher 5/100.

Example :

$$S1 = H + X = 1.7 + 0.1 = 1.8 \text{ mm}$$

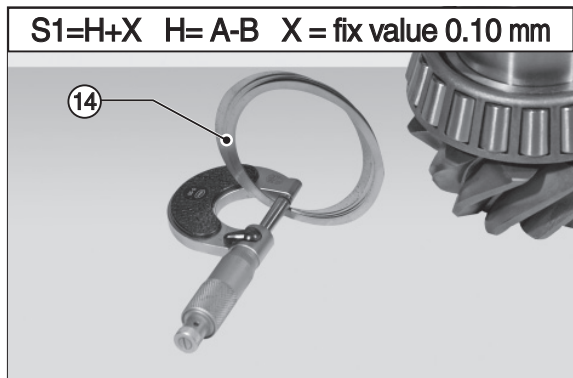

7409FAX238

- (9) Insert distance piece (27) and shims “S1” (26).

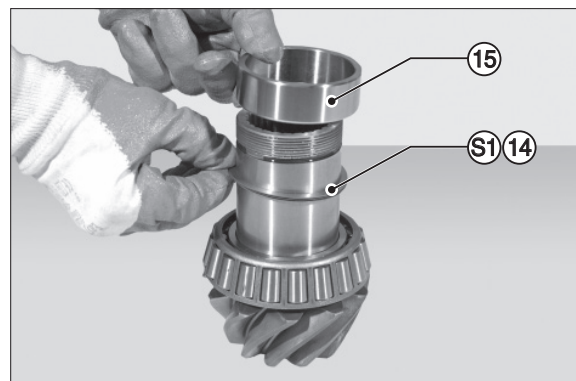

7409FAX239

(10) Oil seal ring lips.

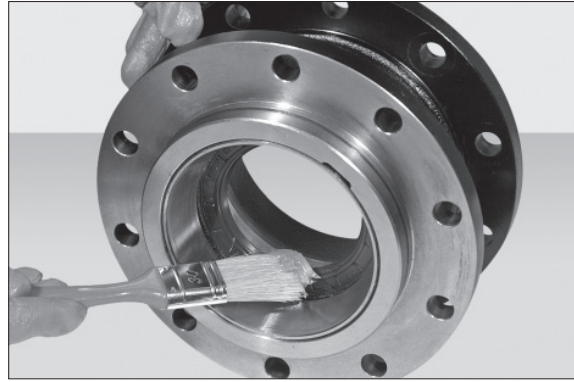

7409FAX240

(11) Insert the cover (5).

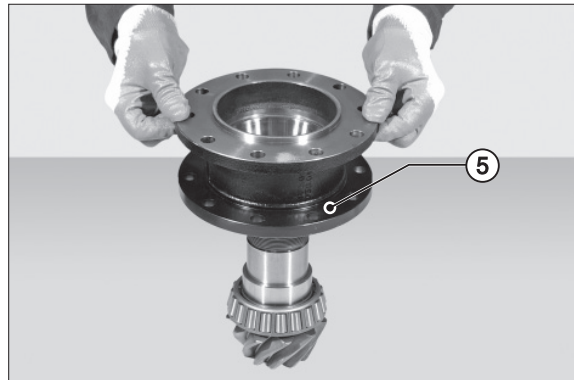

7409FAX241

(12) Heat the outer bearing (2) to about 100 °C and fit it to the pinion (1).

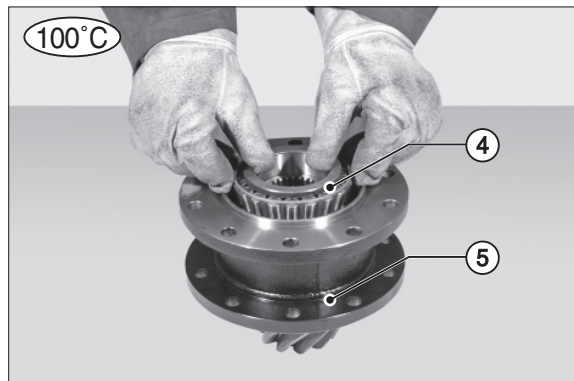

7409FAX242

(13) Insert distance piece (3)

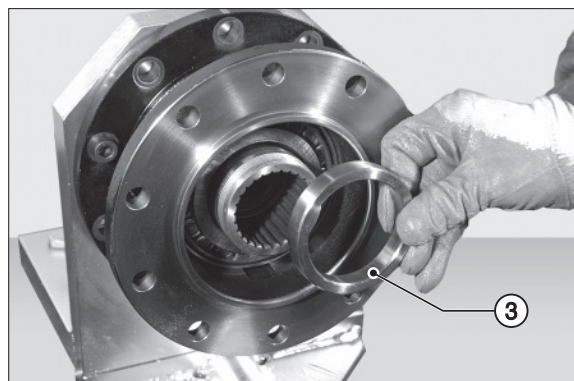

7409FAX243

- (14) Apply Loctite 242 to the thread of the pinion ring nut (10) and screw the nut onto the pinion.

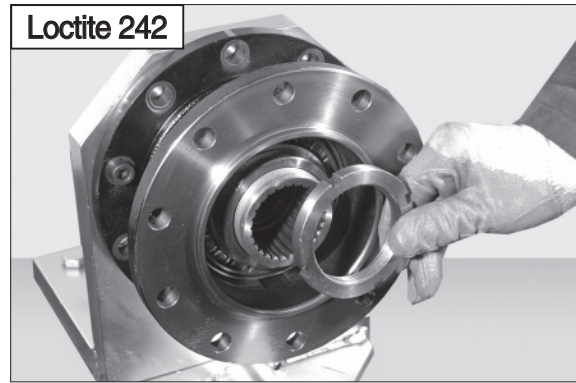

7409FAX244

- (15) Lock the wrench T8, rotate the pinion using a dynamometric wrench, up to a minimum required torque setting of 61.2~81.6 kgf · m (443~590 lbf · ft).



7409FAX245

- (16) Apply onto the pinion (18) the special tool T8 and with the help of a torque meter, check the torque of the pinion (18).

· Torque : 14.3~19.4 kgf · cm

- ※ If torque exceeds the maximum value, then the size of shim "S1" (14) between the bearing (4) and the distance piece (15) needs to be increased.

If torque does not reach the set value, increase the torque setting of the ring nut (10) in different stages to obtain a maximum value of 61.2~81.6 kgf · m (443~590 lbf · ft)

- ※ If torque does not reach the minimum value, then the size of shim "S1" (14) needs to be reduced.

- ※ When calculating the increase or decrease in size of shim "S1", bear in mind that a variation of shim of 0.01 mm corresponds to a variation of 6.12 kgf · cm in the torque of the pinion (18).

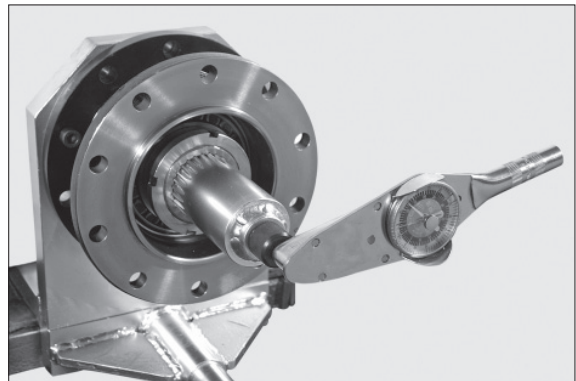

7409FAX246

Calculating pinion center distance

- (17) Using a faceplate, reset a centesimal comparator "DG" on a calibrated block (whose known thickness is 25 mm).

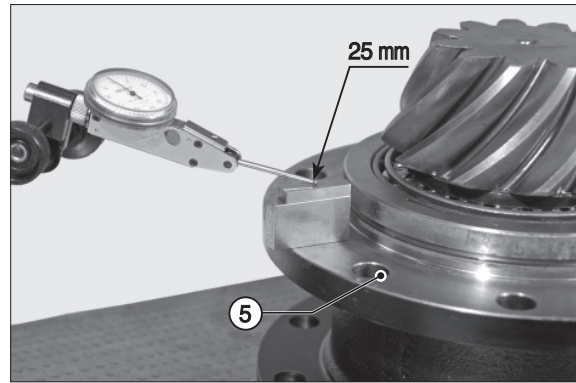

7409FAX247

- (18) Bring internal bearing (2) under comparator "DG", test the difference for calculating of D

$$D = 25 + H = 25 + 0.5 = 25.8 \text{ mm}$$

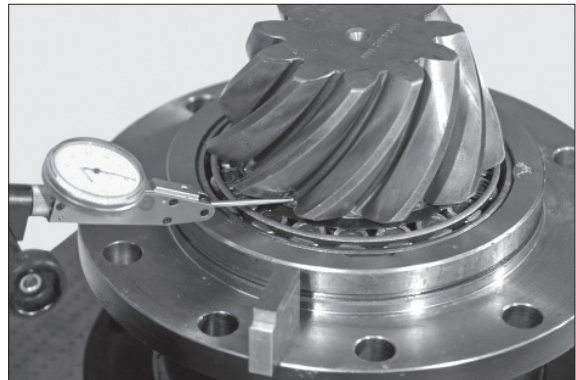

7409FAX248

- (19) Check nominal dimension "I" as marked on the pinion. Add up to or subtract from "I" the variation indicated as "Y" to obtain the actual center distance "I".

Example :

$$I = \text{INT} \pm Y = 153 - 0.1 = 152.9 \text{ mm}$$

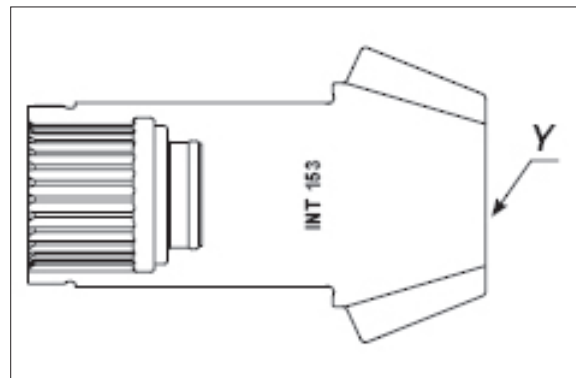

7409FAX249

- (20) Shims "S" for insertion :

$$S = (I + D) - X = (152.9 + 25.5) - 178 = 0.7 \text{ mm}$$

I = Actual pinion center distance

D = Bearing distance

X = 178 mm = Fix dimension

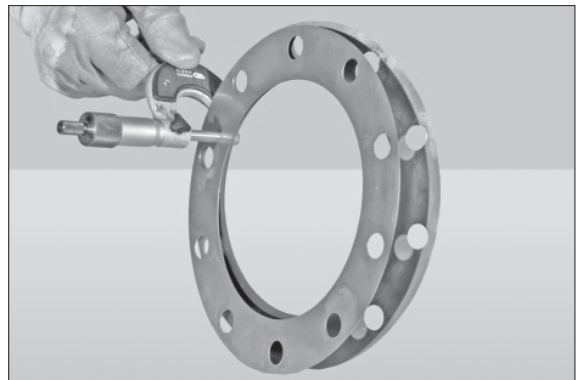

7409FAX250

- (21) Install a new seal ring (12).
Lubricate the seal ring before fitting.

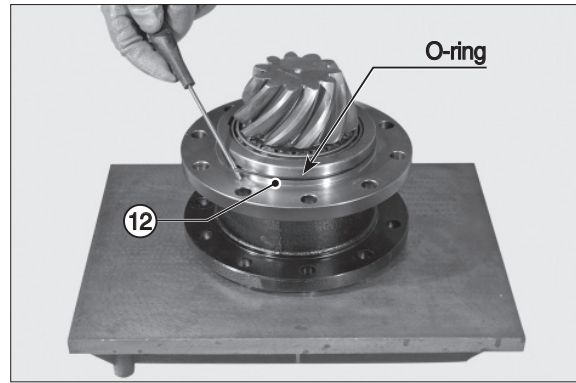

7409FAX251

- (22) Install shims (11) and cover (5).

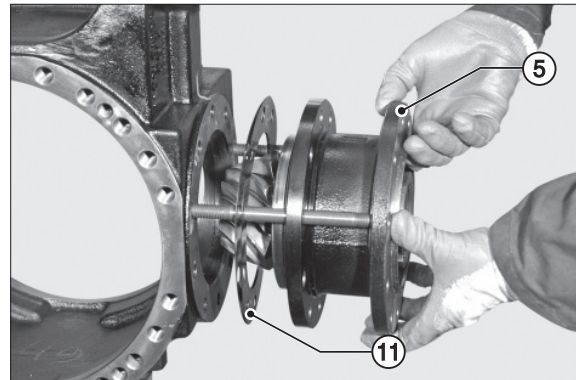

7409FAX252

- (23) Secure in position with the screws (6) and relative washers (7), coated with loctite 270.

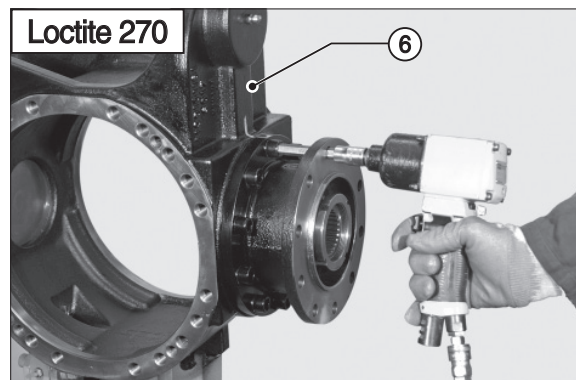

7409FAX253

- (24) Using the criss-cross method and a tightening torque of 13.2~14.6 kgf · m (95.5~106 lbf · ft)

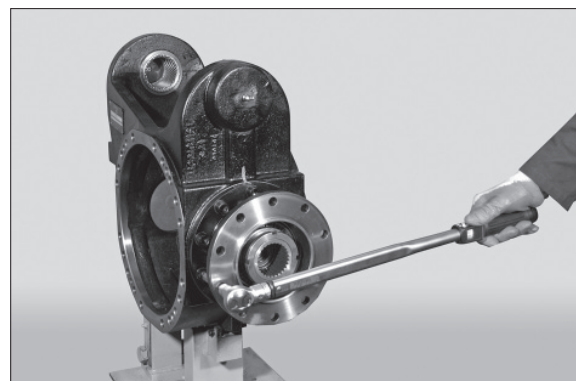

- (25) Install a new seal ring (1).
Lubricate the seal ring before fitting.

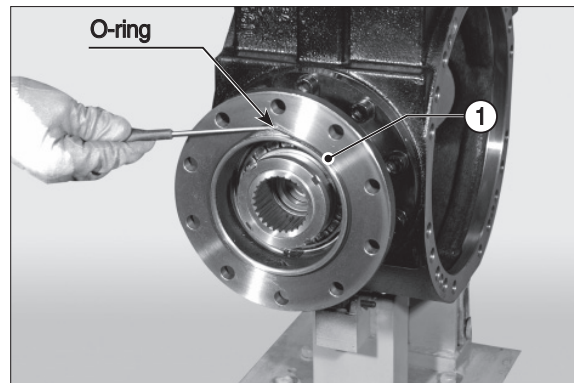

7409FAX255

- (26) Refit the reduction unit onto the axle.
Fasten the support planes (turn flange to assist assembly).
Insert nuts by applying loctite 242.
Tighten nuts using a torque wrench setting of 13.2~14.6 kgf · m (95.5~106 lbf · ft).

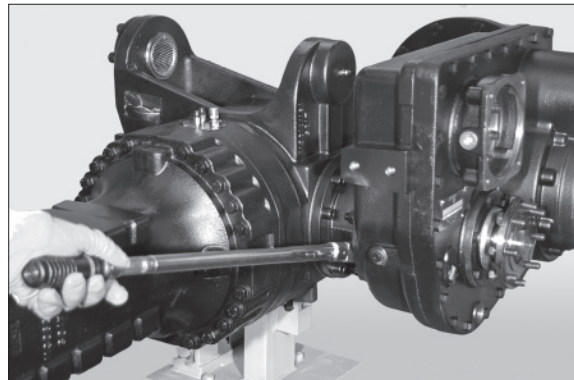

7409FAX256

13) REMOVING AND DISASSEMBLING THE HYDRAULIC DIFFERENTIAL UNIT

Removal

- (1) Pull out the arms.
For details, see CHECKING WEAR AND REPLACING THE BRAKE DISCS.

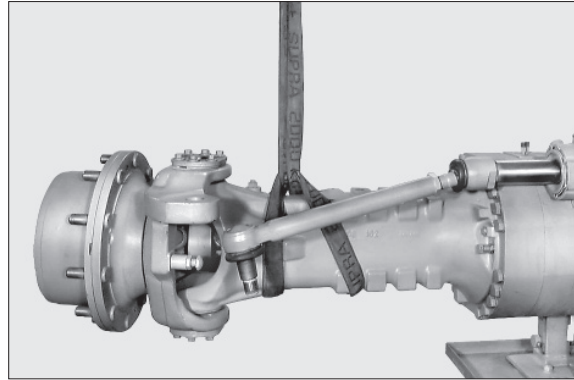

7409FAX257

- (2) Remove both guard (1) and differential-lock-enabled microswitch indicator (2).

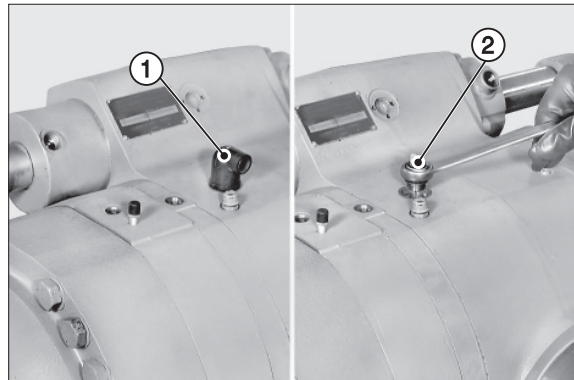

7409FAX258

- (3) Tighten two safety studs "A" (M16) in two opposing holes in the main body (3). Loosen and remove the screws (4).

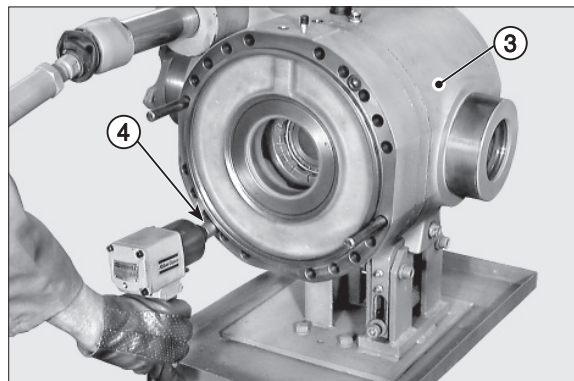

7409FAX259

- (4) Connect to a hoist and remove the whole brake cylinders (5).

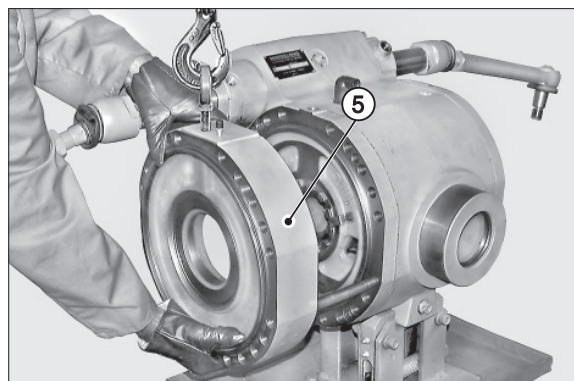

7409FAX260

- (5) Remove screws (6) and safety stops (7) from adjustment ring nuts (8).

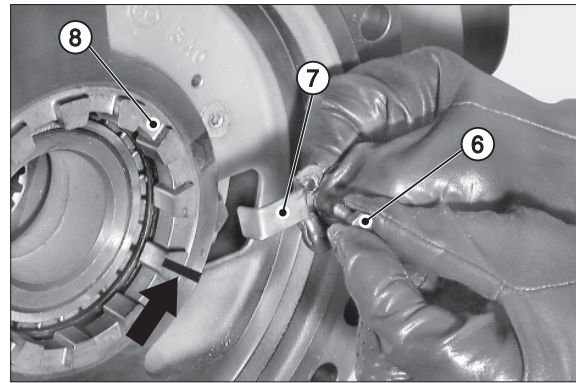

7409FAX261

- (6) **Only if locking piston seal is replaced :** make positional match marks across the adjustment ring nut on non-gear ring side. Loosen the ring nut (8) by about 6 mm (4 turns).

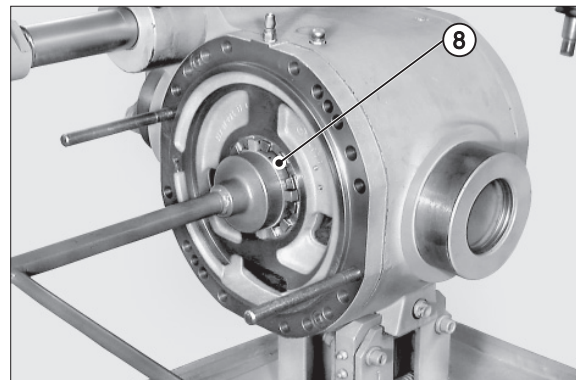

7409FAX262

- (7) Loosen and remove check screws (9) from intermediate cover (10) and apply a compressed air connection "B" to the lock's pressure intake hole.

Thread : M14 X 1.5

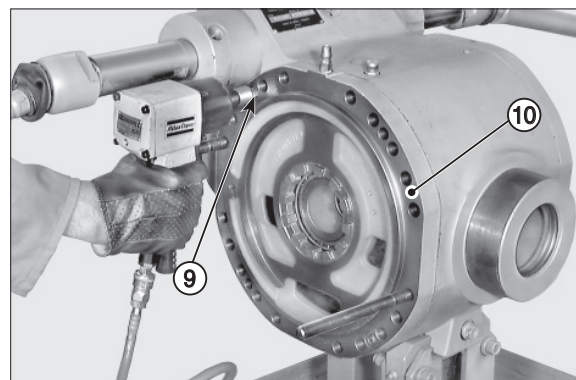

7409FAX263

- (8) Introduce low-pressure compressed air through connection "B" and make sure that the lock control piston comes out at end of stroke. Remove safety studs, rotate cover (10) to an angle of about 45° and remove cover.

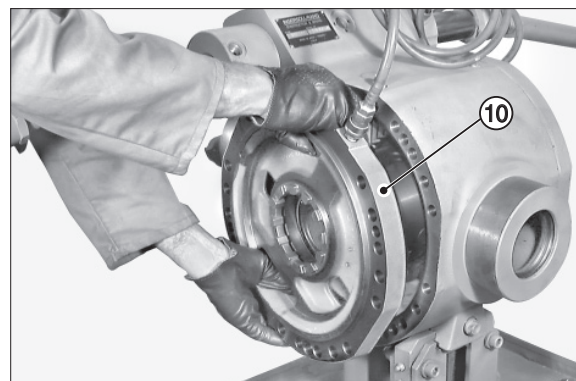

7409FAX264

- (9) Tighten two safety studs "A" (M16) in the main body.
Loosen and pull out check screws (9) from intermediate cover (11) on gear ring side.

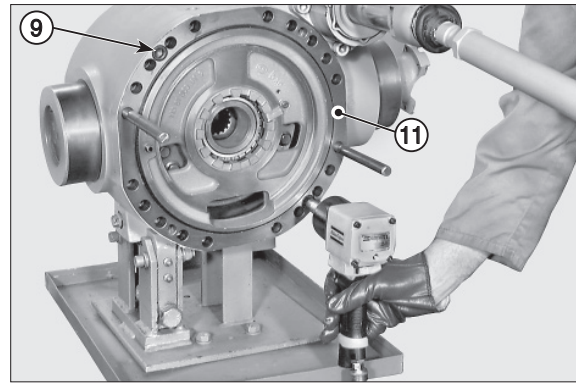

- (10) Support the differential unit and disconnect intermediate cover (11) from main body (3).
Pull out cover (11).

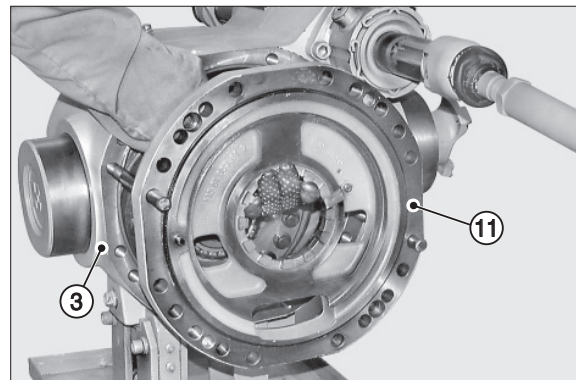

- (11) Remove the differential unit by using tool T13; position the unit on a workbench.

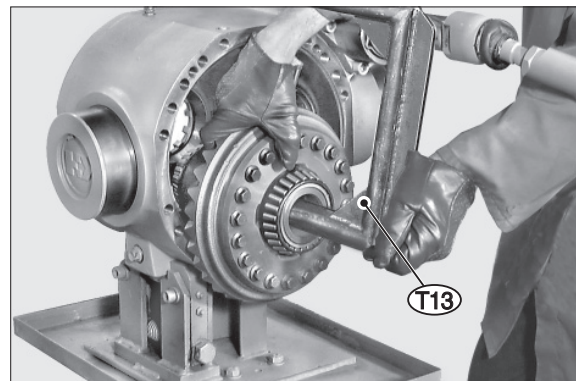

- (12) Remove the snap ring (12) and locking cap (13).

※ Replace the cap at each disassembly.

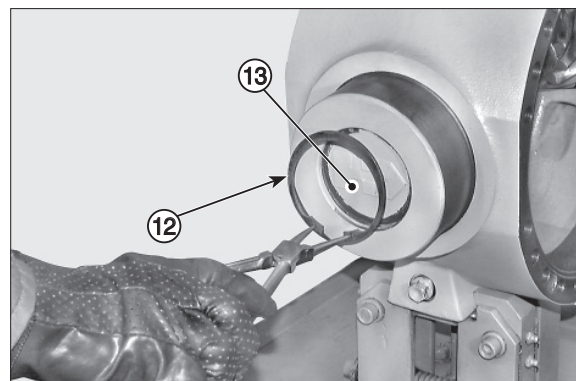

Control disassembly

- (13) As you hold piston (14) in position, loosen check nut (15) of fork (16).
Remove nut (15) and spring washer (21).

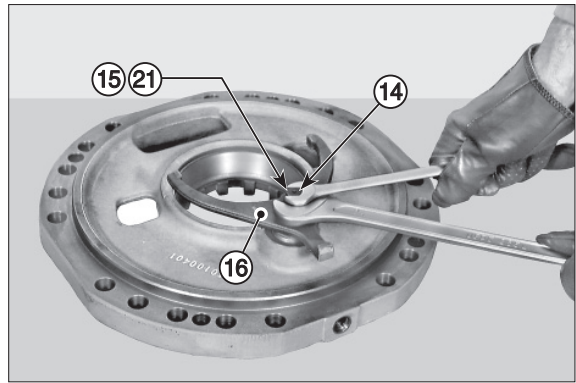

7409FAX269

- (14) Remove fork (16).
※ Note down direction of installation and thoroughly inspect pad for wear.

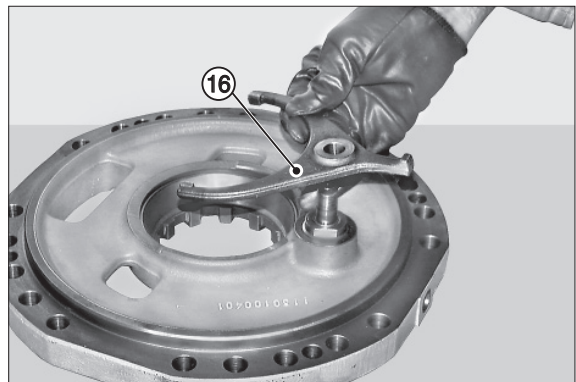

7409FAX270

- (15) Loosen piston stop ring nut (17); remove ring nut and spring (18).

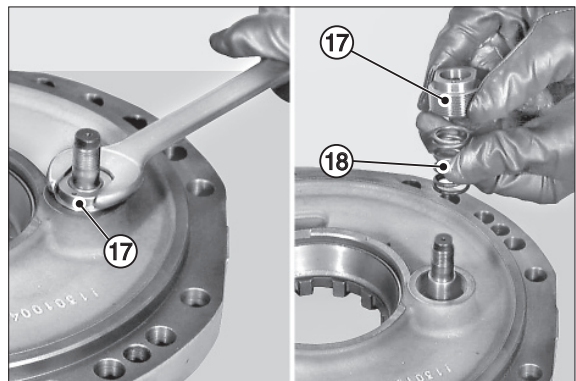

7409FAX271

- (16) Remove piston (14) complete with O-ring (19) and guide pad (21).
※ Replace pad and O-ring at each disassembly.

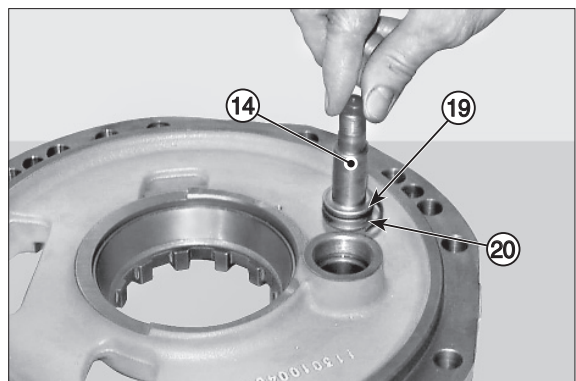

7409FAX272

- (17) If bearings need replacing, remove the outer thrust blocks of bearings (44) from intermediate covers (10) and (11).

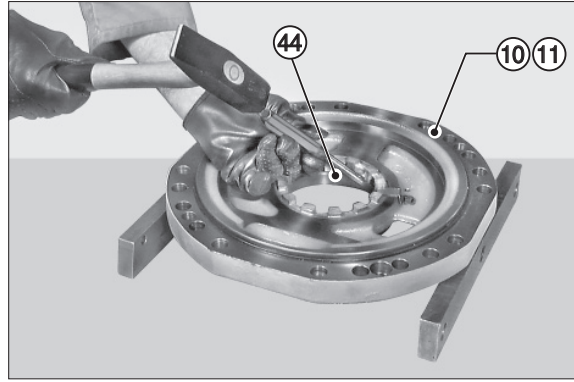

7409FAX273

Disassembling the brake piston

- (18) Gently introduce low-pressure compressed air through the connection of the working brake line and eject the whole piston (22).

※ Replace seals (23) and (24) and anti-extrusion rings at each disassembly.

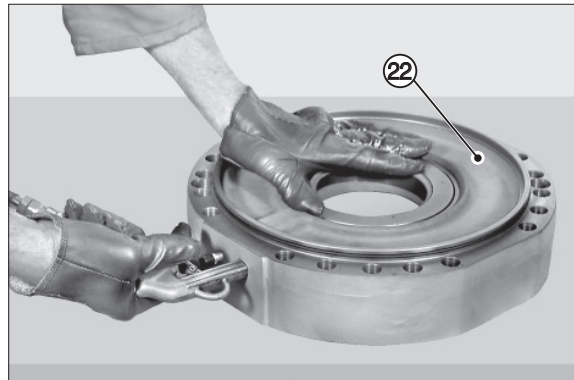

7409FAX274

Disassembling the differential gear

- (19) With a puller applied under coupling (25), pull out bearing (44) and shoulder (26) for coupling (25).

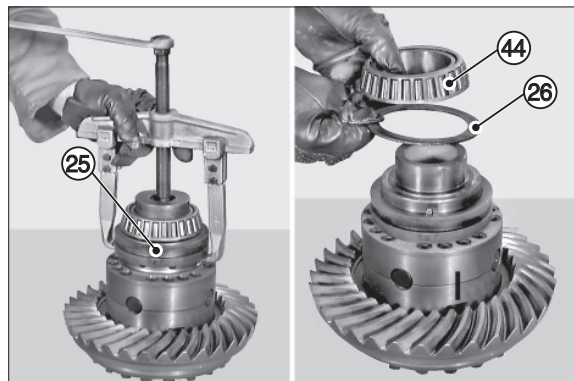

7409FAX275

- (20) Remove coupling (25) and collect the drive balls (27).

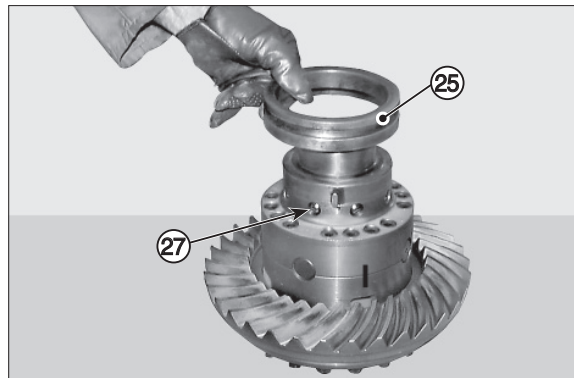

7409FAX276

(21) **Only if necessary** : remove guide key (28) from coupling (25).

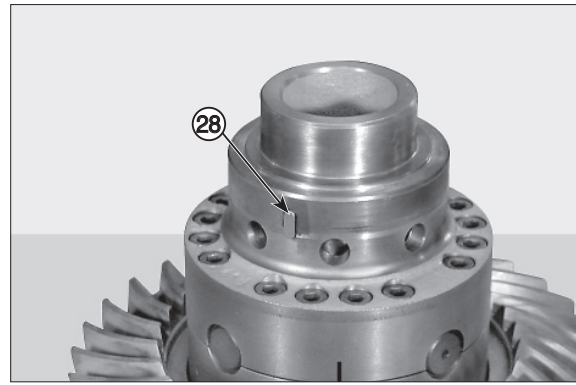

7409FAX277

(22) Make positional marks on the half-boxes of differential (29); loosen and remove joining screws (30).

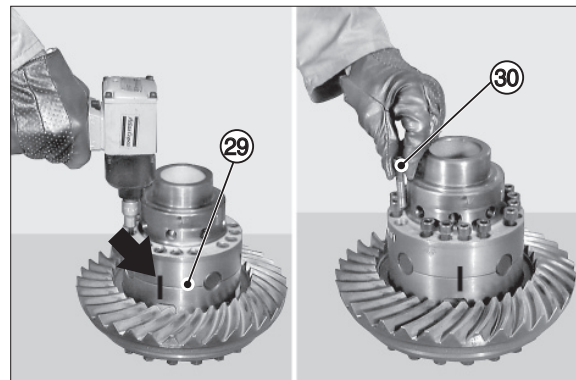

7409FAX278

(23) Remove upper half box (31), and then pull out shoulder ring (32) and crown wheel (33).

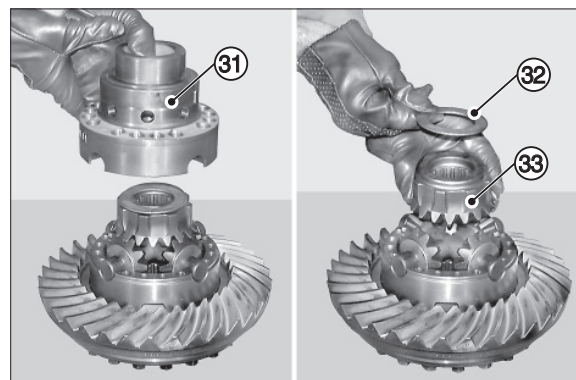

7409FAX279

(24) Complete differential disassembly procedure by following the instructions given in REMOVING AND DISASSEMBLING THE DIFFERENTIAL UNIT.

Replacing the brake discs

- (25) Loosen and then remove lock nuts (34) (3EA) ; also remove seal washers (35).

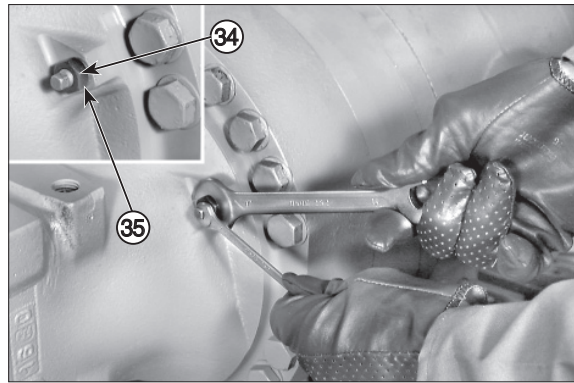

7409FAX280

- (26) Remove screws (36), springs (37) and pressure plate (38).
Proceed by removing the brake discs.
(for details, see REPLACING DISCS AND BRAKE SEALS).

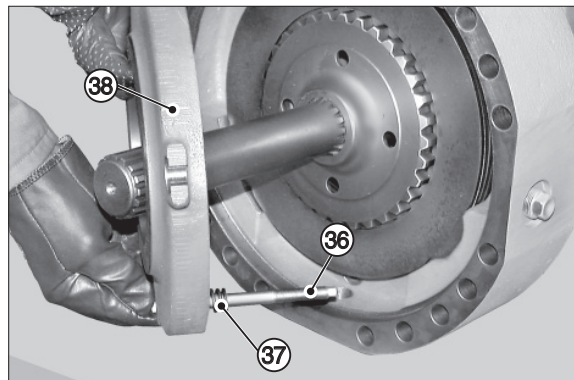

7409FAX344

14) ASSEMBLING AND INSTALLING THE HYDRAULIC DIFFERENTIAL UNIT

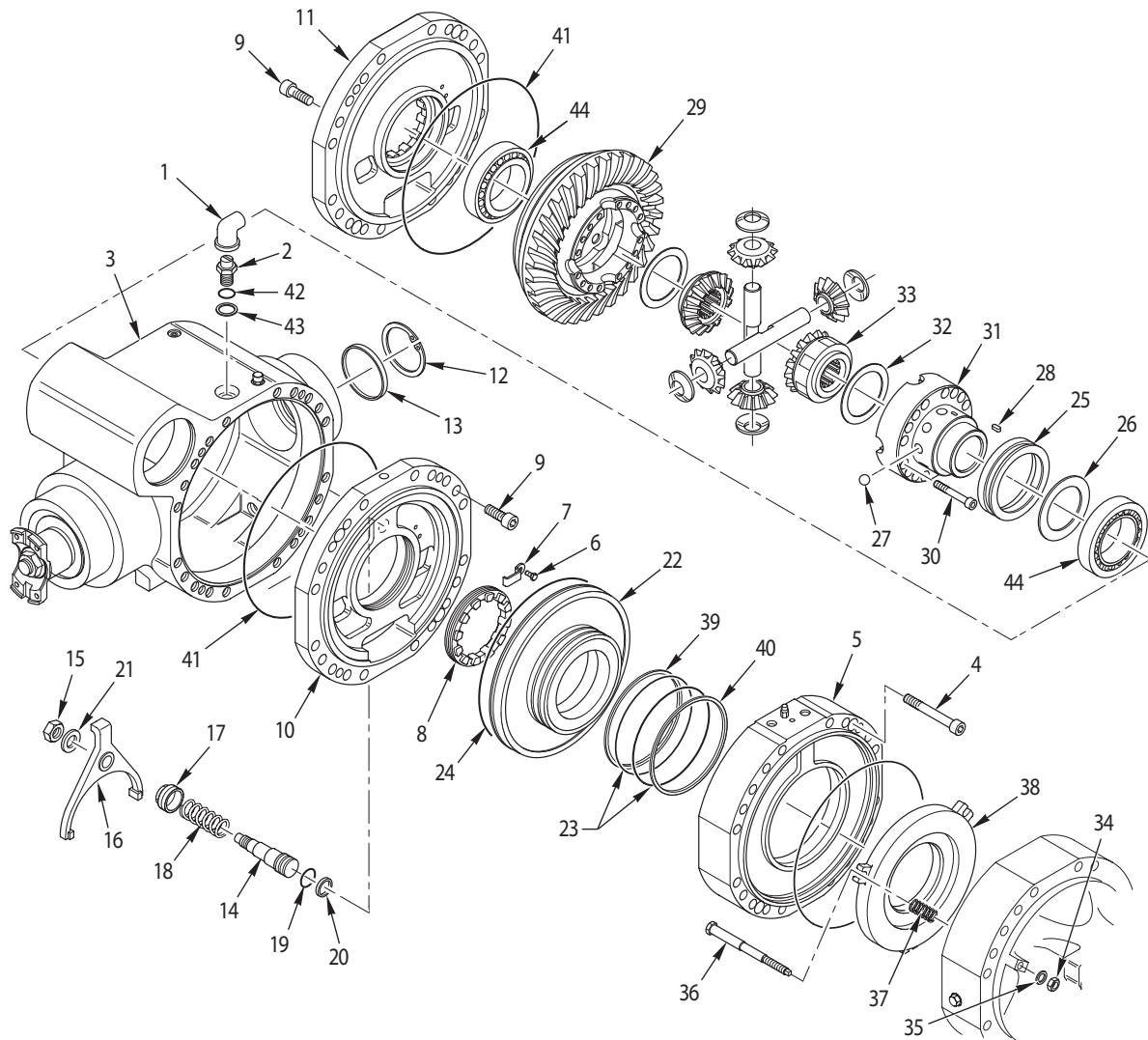

7409FAX281

Only if differential has been disassembled

- (1) Assemble the differential unit (29).
For details, see ASSEMBLING THE DIFFERENTIAL UNIT.
Put the guide key (28) of coupling (25) in place.

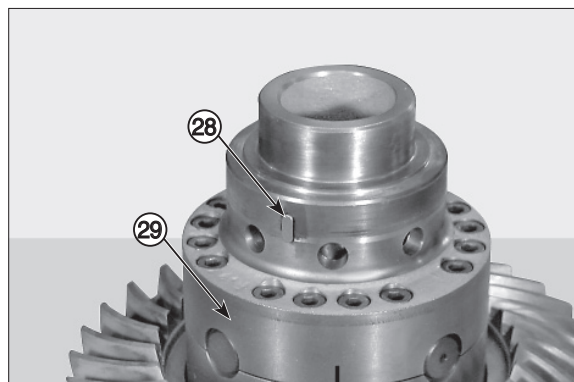

7409FAX282

- (2) Grease the ball slots and fit in the balls (27), coupling (25) and shoulder (26).

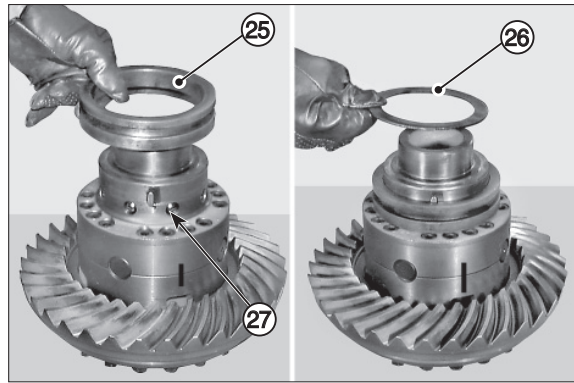

7409FAX283

- (3) Heat bearing (44) to approx. 90°C and install on the differential.

※ Make sure that the bearing is securely engaged.



7409FAX284

Assembling lock control

- (4) Fit O-ring (19) and guide ring (20) onto piston (14).
Lubricate the seals and introduce the unit in tool T19.

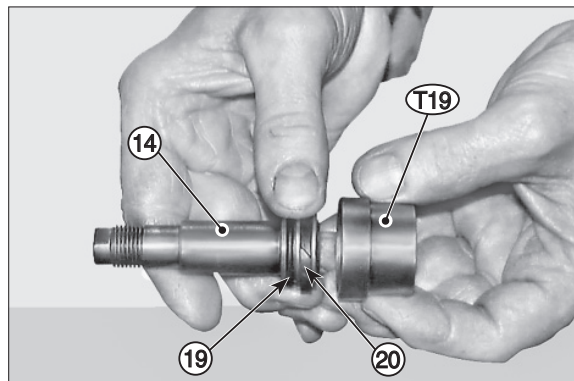

7409FAX285

- (5) Place tool T19 on the intermediate cover (10) and push piston (14) into its seat.

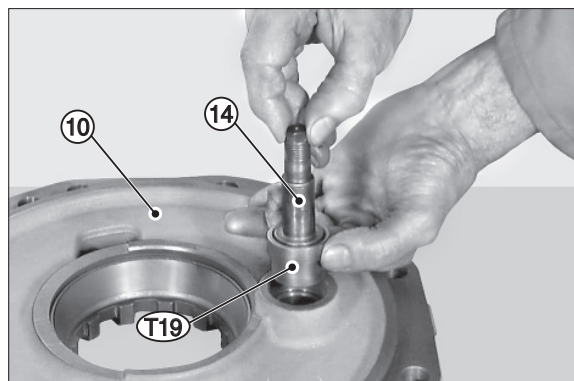

7409FAX286

- (6) Fit spring (18) and ring nut (17) on piston (14). Tighten the ring nut by a few turns, apply a coat of loctite 242 to the ring nut and tighten to a torque of MAX 5.1 kgf · m (36.9 lbf · ft) using a dynamometric wrench.

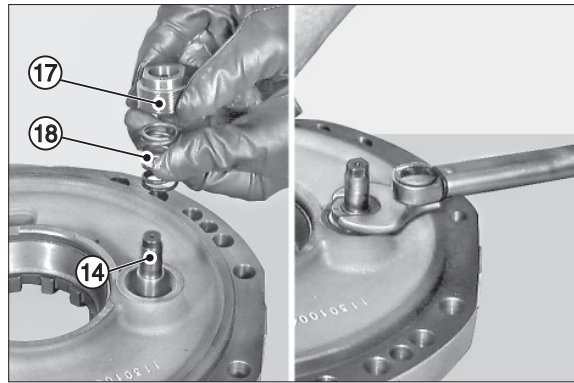

7409FAX287

- (7) Fit fork (16) on piston (14) and make sure fork orientation is correct.

※ Microswitch activation cam "A" must face upwards.

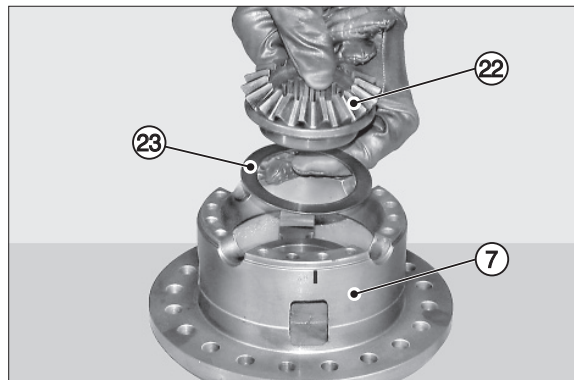

7409FAX288

- (8) Secure fork (16) with snap washer (21) and nut (15).

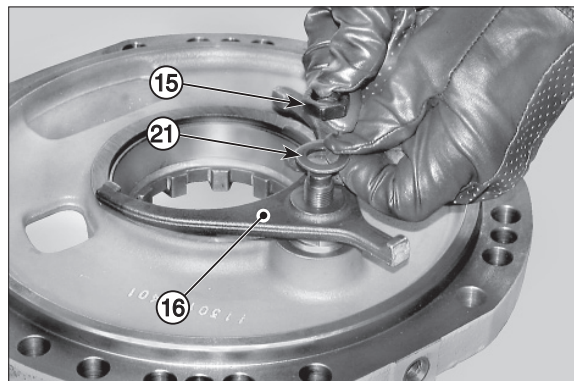

7409FAX289

- (9) As you hold piston (14) in position, lock the nut (15) with a dynamometric wrench.

· Tightening torque : 22.9~23.5 kgf · m
(166~170 lbf · ft)

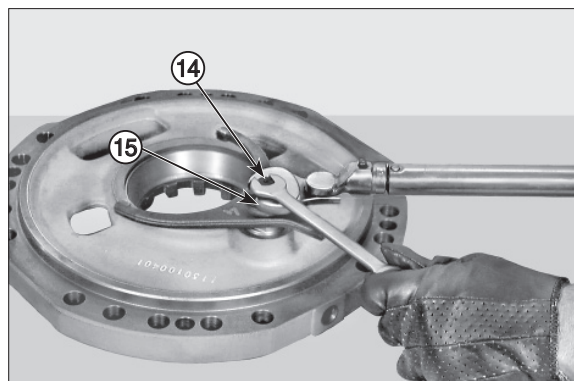

7409FAX290

Assembling the brake piston

(10) Fit O-rings (23), (24) and anti-extrusion rings (39) and (40) on piston (22).

- ※ Thoroughly check the positioning of anti-extrusion rings (39) and (40). Lubricate the seals and introduce piston (22) into cylinder (5).

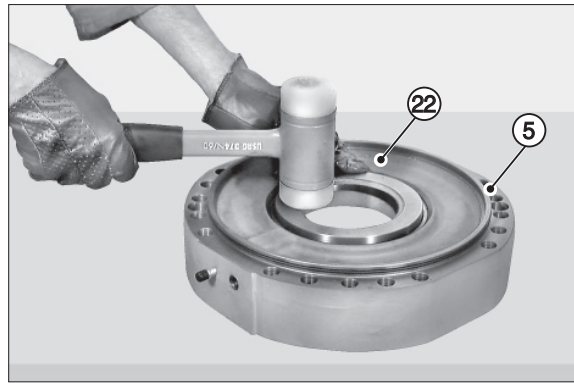

7409FAX291

Installation

(11) Using tool T13, introduce the whole differential (3) into the main body (29).

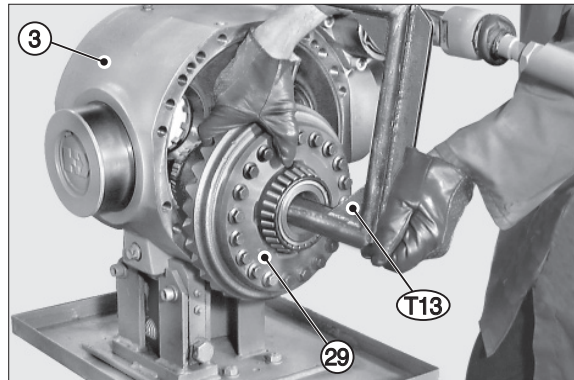

7409FAX292

(12) Tighten two safety studs in the main body (3) and install the intermediate cover (11). Lock in position with screws "V" tightened to a matching torque.

- Tightening torque : 13.3~14.6 kgf · m
(96.2~106 lbf · ft)

- ※ Check the state of the O-ring (41).

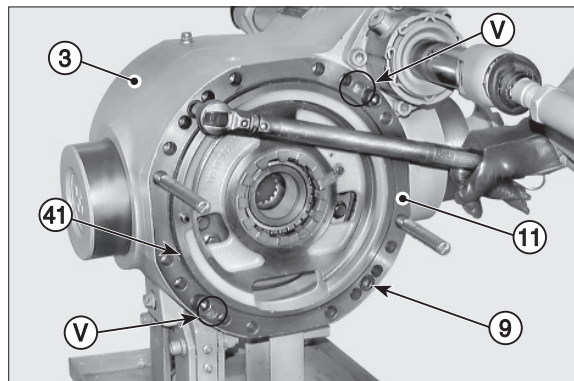

7409FAX293

(13) Introduce low-pressure compressed air through connection "B" and make sure that the lock control piston comes out at the end of stroke.

Rotate the intermediate cover (10) to an angle of about 45°; engage the fork (16) in the lock control coupling (25).

- ※ Check the condition of the O-ring (41).

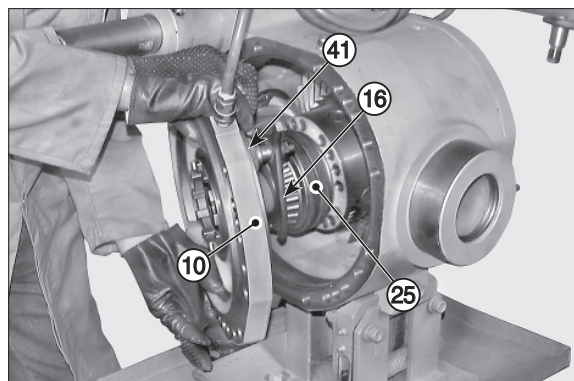

7409FAX294

(14) As you hold the fork in position (16), rotate the intermediate cover into its final position (10).

To lock into position, tighten two safety studs "A" in two opposing holes.

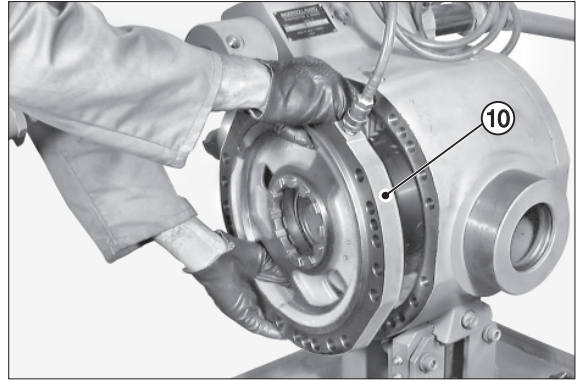

7409FAX295

(15) Clear any compressed air and finally move the intermediate cover (10) into its seat. Lock into position with nuts "V" tightened to matching torque.

- Tightening torque : 13.3~14.6 kgf · m
(96.2~106 lbf · ft)

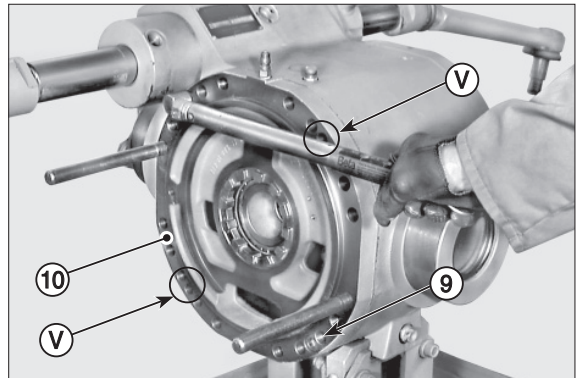

7409FAX296

(16) If necessary, adjust differential clearances (see ASSEMBLING THE DIFFERENTIAL UNIT).

Fit the cap (13) and snap ring (12).

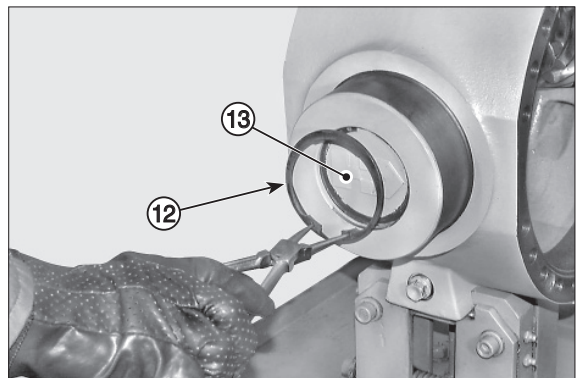

7409FAX297

(17) Fit the microswitch (2) complete with the O-ring (42) and the relative retainer ring (43).

Install the arms (see CHECKING WEAR AND REPLACING THE BRAKING DISCS).

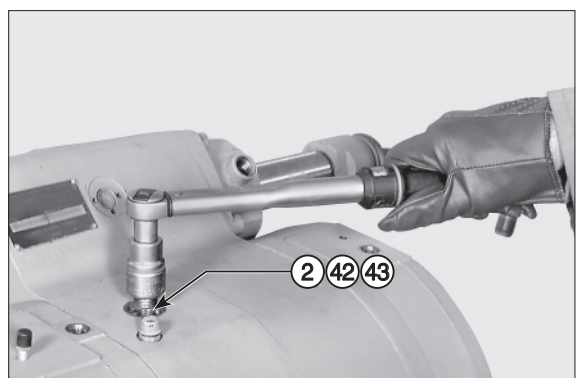

7409FAX298

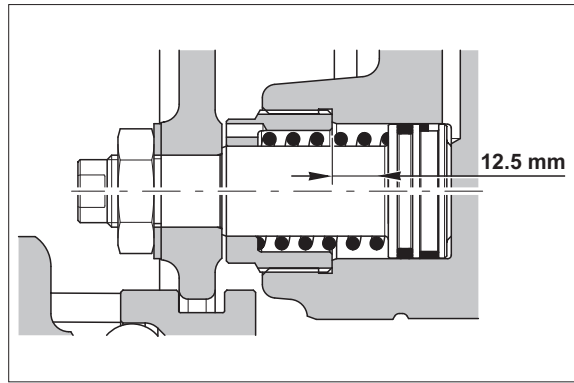

7409FAX299

15) ADJUSTING THE SERVICE BRAKE

※ Perform brake adjustment on both sides of the axle.

- (1) Loosen the lock nuts (34) and unscrew by a few turns.

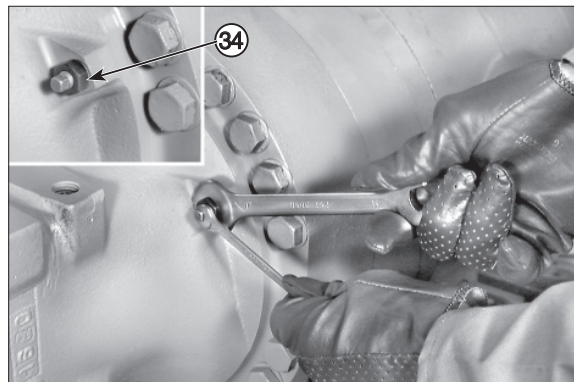

7409FAX300

- (2) Introduce pressure at 20.4~30.6 kgf/cm² (290~435 psi) bar into the service brake. Turn the adjusting screws (36) anti-clockwise until they lean against the pressure plate.

Clearance between discs = 0 mm

※ Turn the screws gradually and by the same measure until a max. torque of 1.02 kgf · m (7.38 lbf · ft) is obtained.

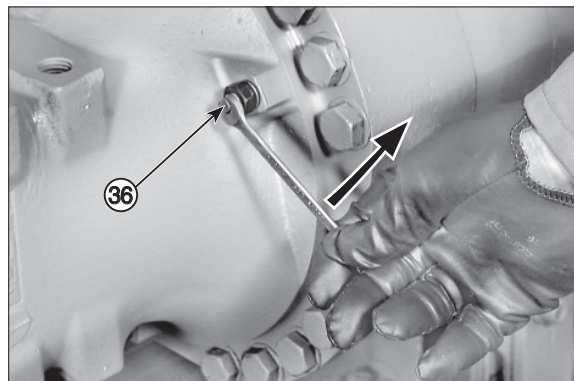

7409FAX301

- (2) Once the jut of the three screws (36) has been checked and found to be equivalent, turn the screws clockwise to restore disc clearance :

1 turn = 1 mm

3/4 of a turn = 0.75 mm

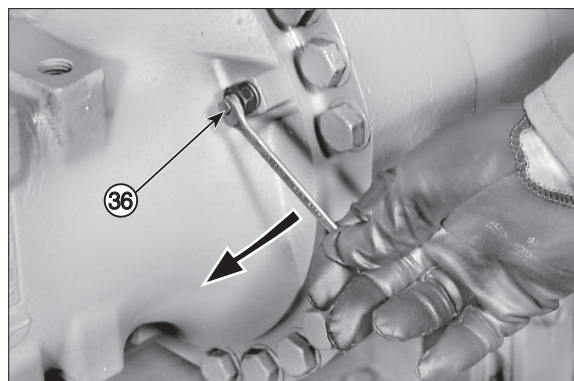

7409FAX302

(3) As you hold the screws (36) in position, lock the nuts (34).

- Nut tightening torque : max 1.53 kgf · m
(11.1 lbf · ft)

Release pressure from service brake.

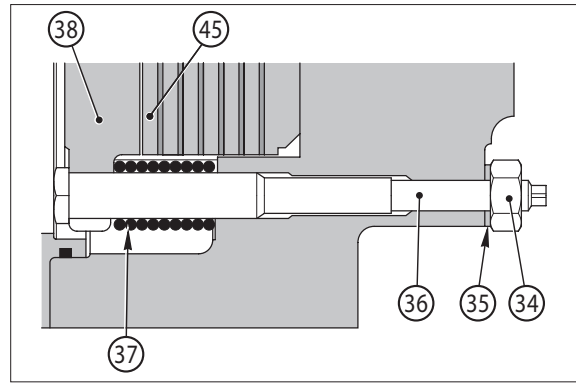

7409FAX303

16) REMOVING AND DISASSEMBLING THE LIMITED SLIP (45%) DIFFERENTIAL

(1) Remove the whole differential unit (2) from the main body (1).
(for details, see REMOVING THE DIFFERENTIAL UNIT).

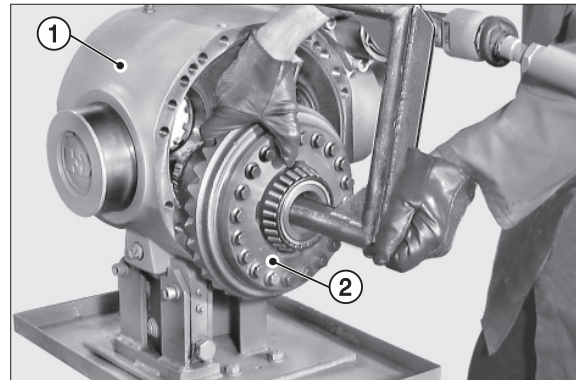

7409FAX304

※ The following section includes clutch replacement procedures only; for gear ring replacement, see DISASSEMBLING THE DIFFERENTIAL UNIT.

(2) Using a puller, remove bearing (3).



7409FAX305

(3) Make positional match marks on the half boxes of the differential gear (2); loosen and pull out joining screws (4).

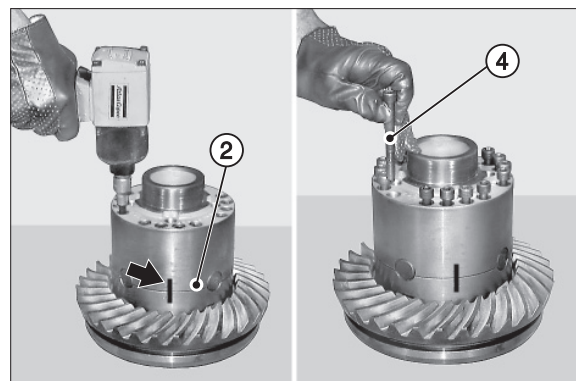

7409FAX306

(4) Remove the upper half box (5) and pull out shims (6) and clutch pack (7).

※ If the clutch pack does not need replacing, avoid swapping discs position.

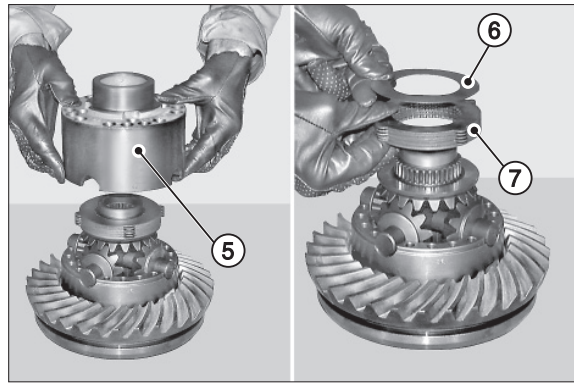

7409FAX307

(5) Remove the crown wheel (8) and planet wheels set (9).

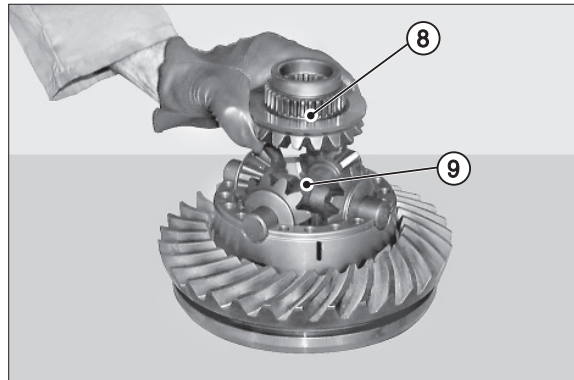

7409FAX308

(6) Remove the 2nd crown wheel (10).

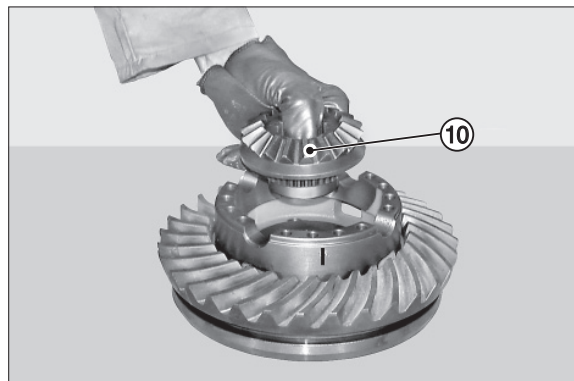

7409FAX309

(7) Remove the 2nd clutch pack (11) and shim set (6).

※ If the clutch pack does not need replacing, avoid swapping discs position.

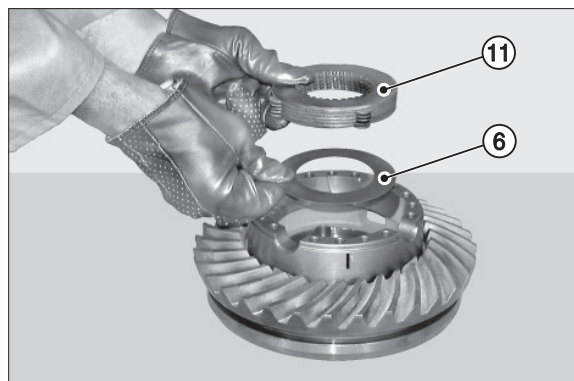

7409FAX310

17) REMOVING AND DISASSEMBLING THE DIFFERENTIAL UNIT

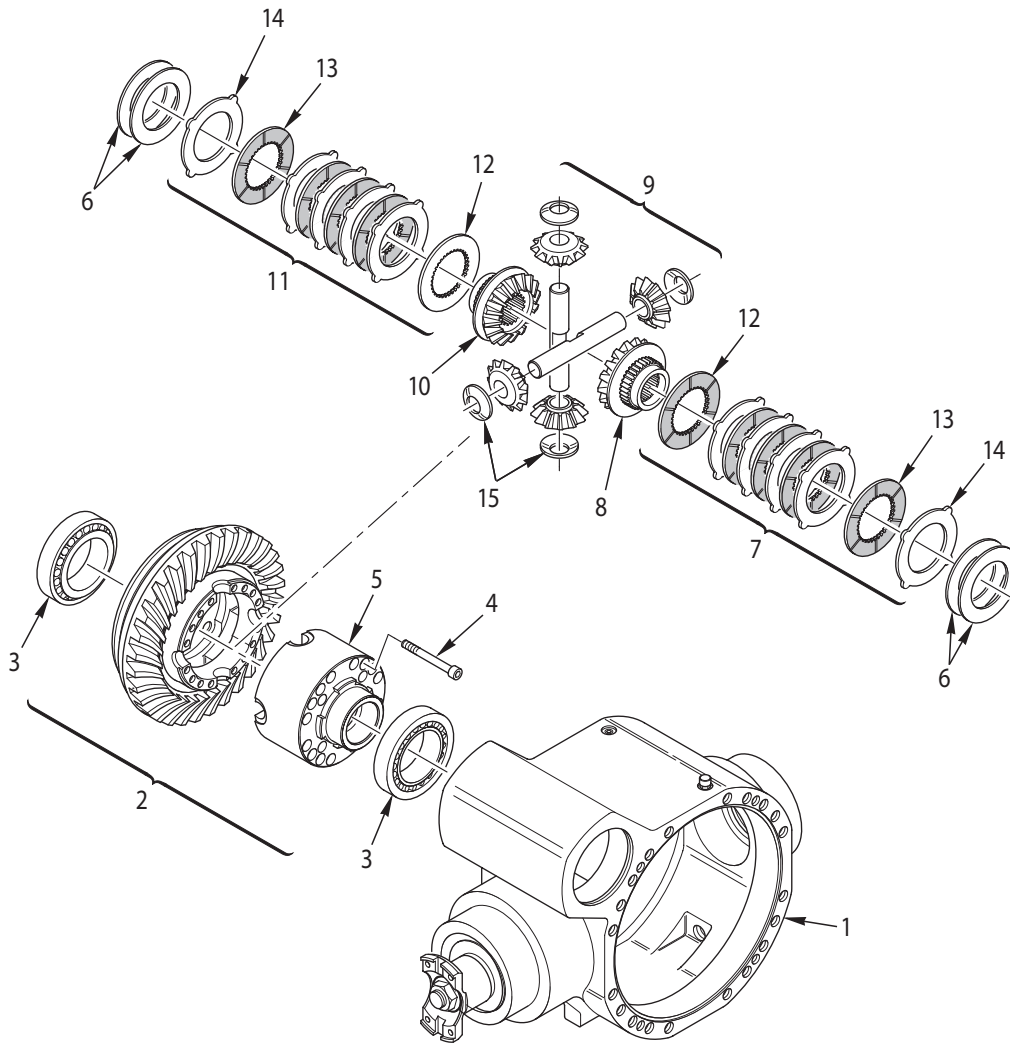

7409FAX311

Removal

- (1) Remove the entire arms and negative brake cylinders.
For details, see CHECKING WEAR-REPLACING DISCS AND BRAKE SEALS.

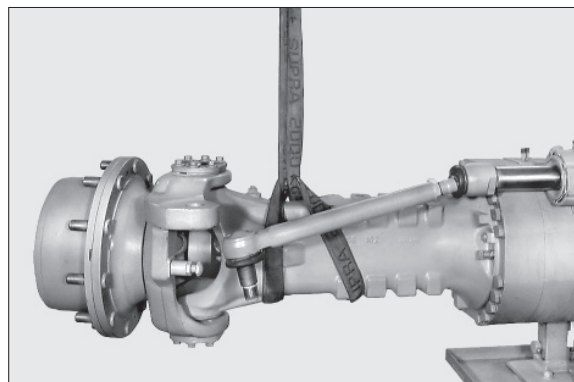

7409FAX312

- Only if need removing or adjusting**
- (2) Mark the position of the ring nuts (1).
Remove screws (3) and ring nut checks (2).

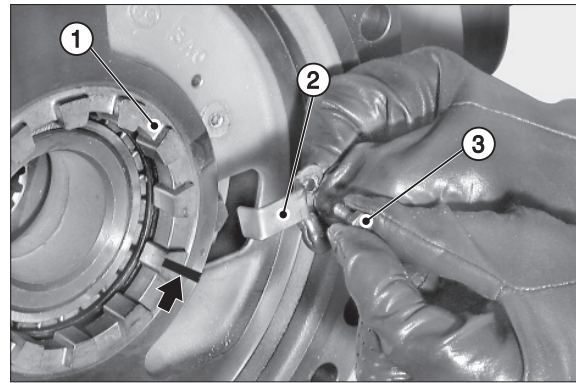

7409FAX313

- Only if need removing or adjusting**
- (3) Heat the ring nuts (1) uniformly to a temperature of about 80°C.

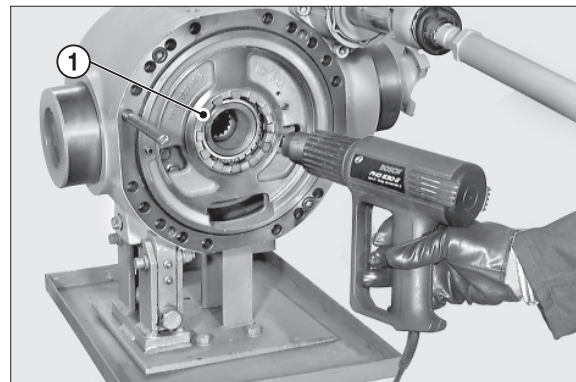

7409FAX314

- Only if need removing or adjusting**
- (4) Using tool T12, loosen and remove the ring nuts (1).
- ※ Accurately remove any trace of sealant from the threads of ring nuts and intermediate covers.

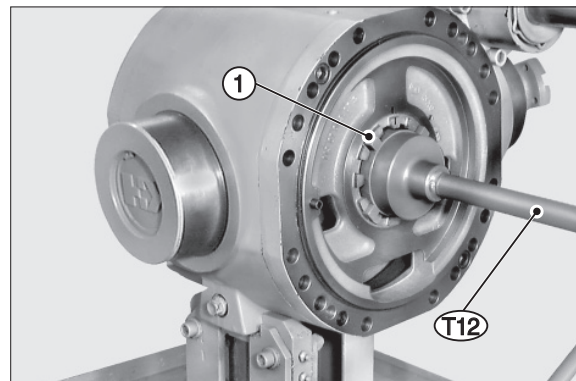

7409FAX315

- (5) Tighten two safety M16 studs in the main body.
Loosen and remove the check screws (5) of intermediate cover (4) on gear ring side.

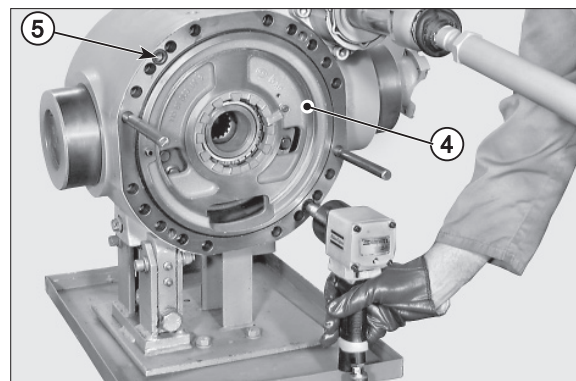

7409FAX316

- (6) Support the differential unit and separate the intermediate cover (4) from the main body (6).
Remove cover (4).

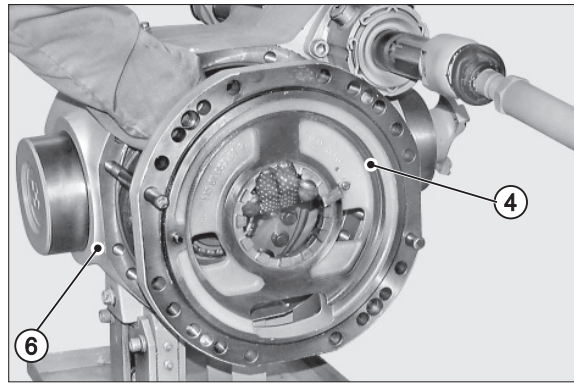

7409FAX317

- (7) Remove the differential unit (7) and place it on a work bench.
※ Use the tool T13 to ease removal.

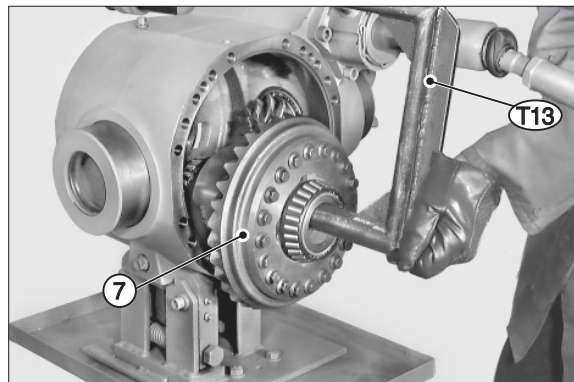

7409FAX318

- (8) If bearings need replacing, remove the outer thrust blocks of bearings (9) from intermediate covers (4) and (8).
※ Carefully check the O-rings (10).

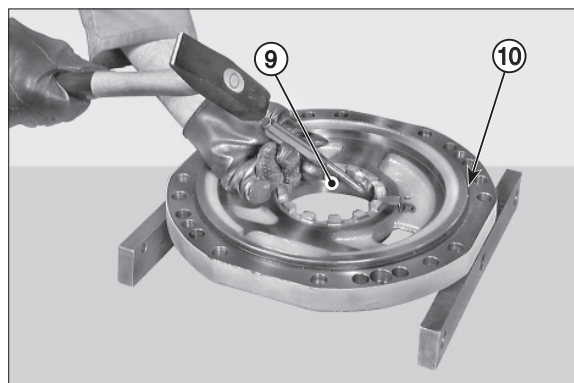

7409FAX319

- (9) Remove snap ring (11) and cap (12).
※ Replace cap at each disassembly.

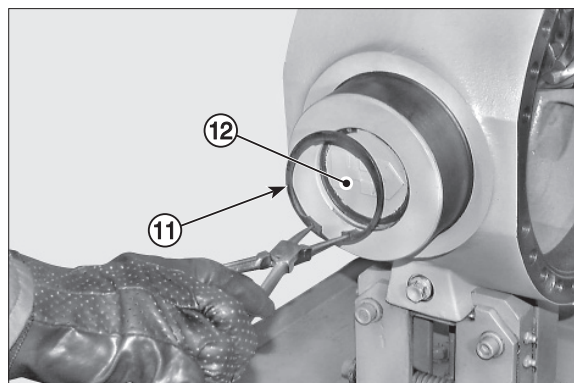

7409FAX320

Disassembly

(10) Using two levers, lift bearing (9) on gear ring side by about 8 mm.

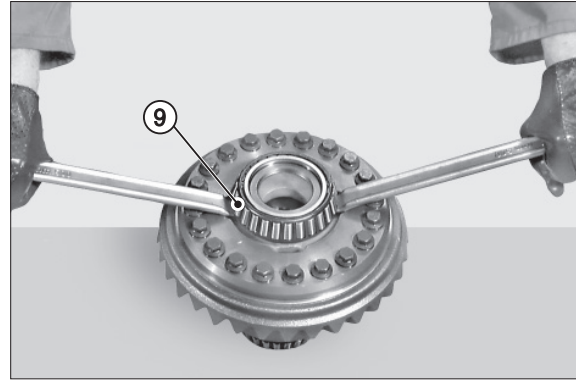

7409FAX321

(11) Loosen and remove the check screws (13) of gear ring (14).

※ The screws must be replaced at each disassembly.

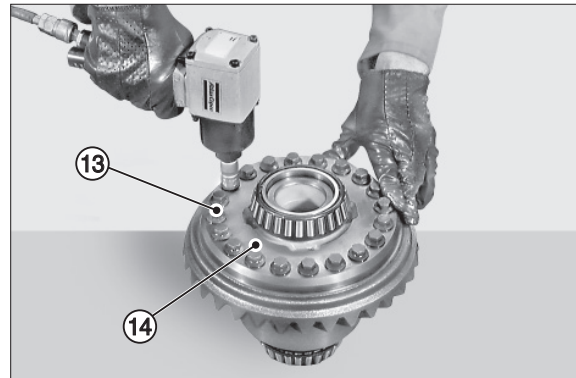

7409FAX322

(12) Remove the gear ring (14).

※ If necessary, use a plastic hammer.



7409FAX323

(13) Using a puller, remove bearings from gear ring (9) side.

※ Fit puller in connection with the slots provided.

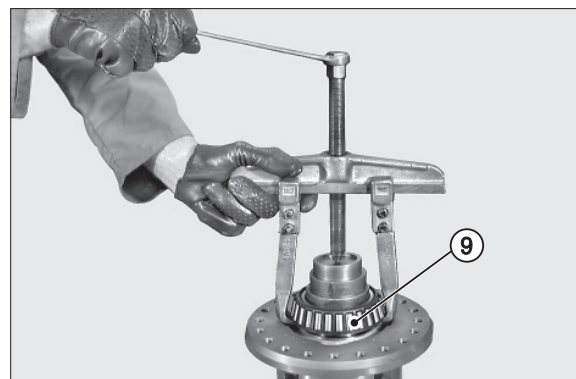

7409FAX324

(14) Using a separator and a puller, remove bearing from non gear ring side.

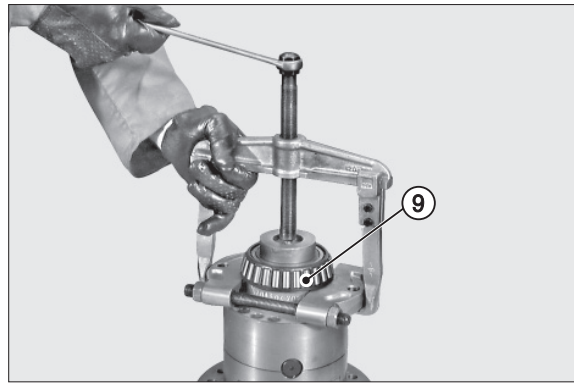

7409FAX325

(15) Loosen and remove check screws (15) from differential box (16).

※ The screws must be replaced at each disassembly.

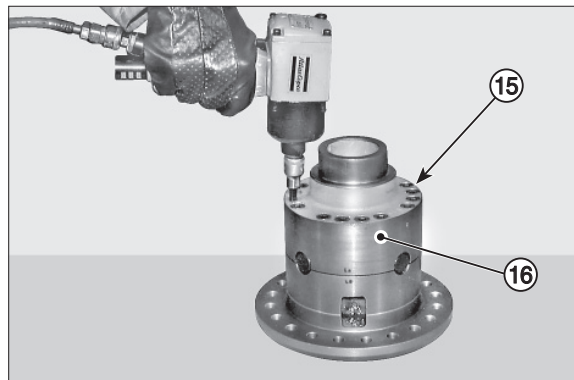

7409FAX326

(16) Remove half-box (16).

※ Note down reference marks for joining the two halves.

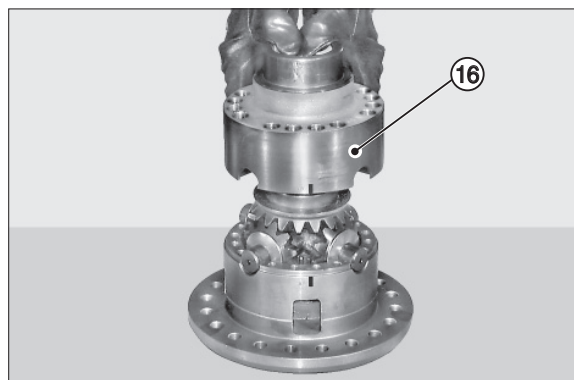

7409FAX327

(17) Remove shoulder (17) and first planetary gear (18).

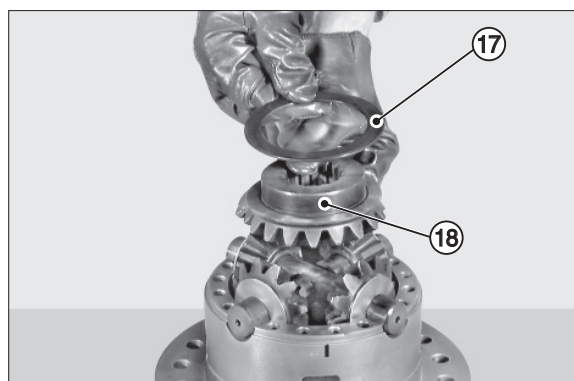

7409FAX328

(18) Remove shafts (19), complete with planet wheels (20) and spherical shoulder washers (21).

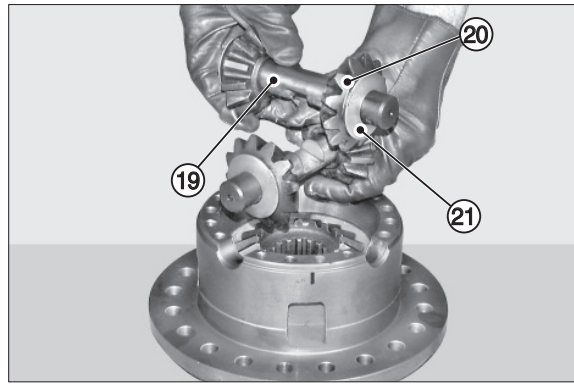

7409FAX329

(19) Remove the 2nd planetary gear (22) and shoulder ring (23).

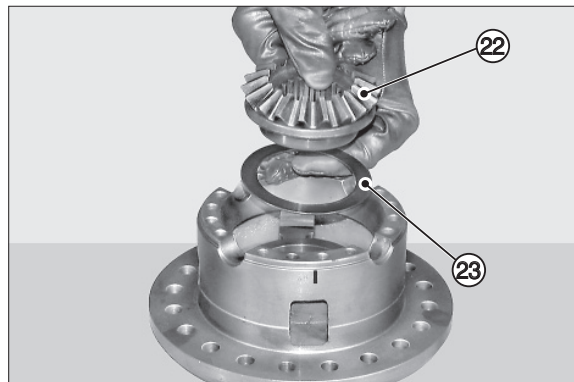

7409FAX330

18) ASSEMBLING AND INSTALLATION THE DIFFERENTIAL UNIT

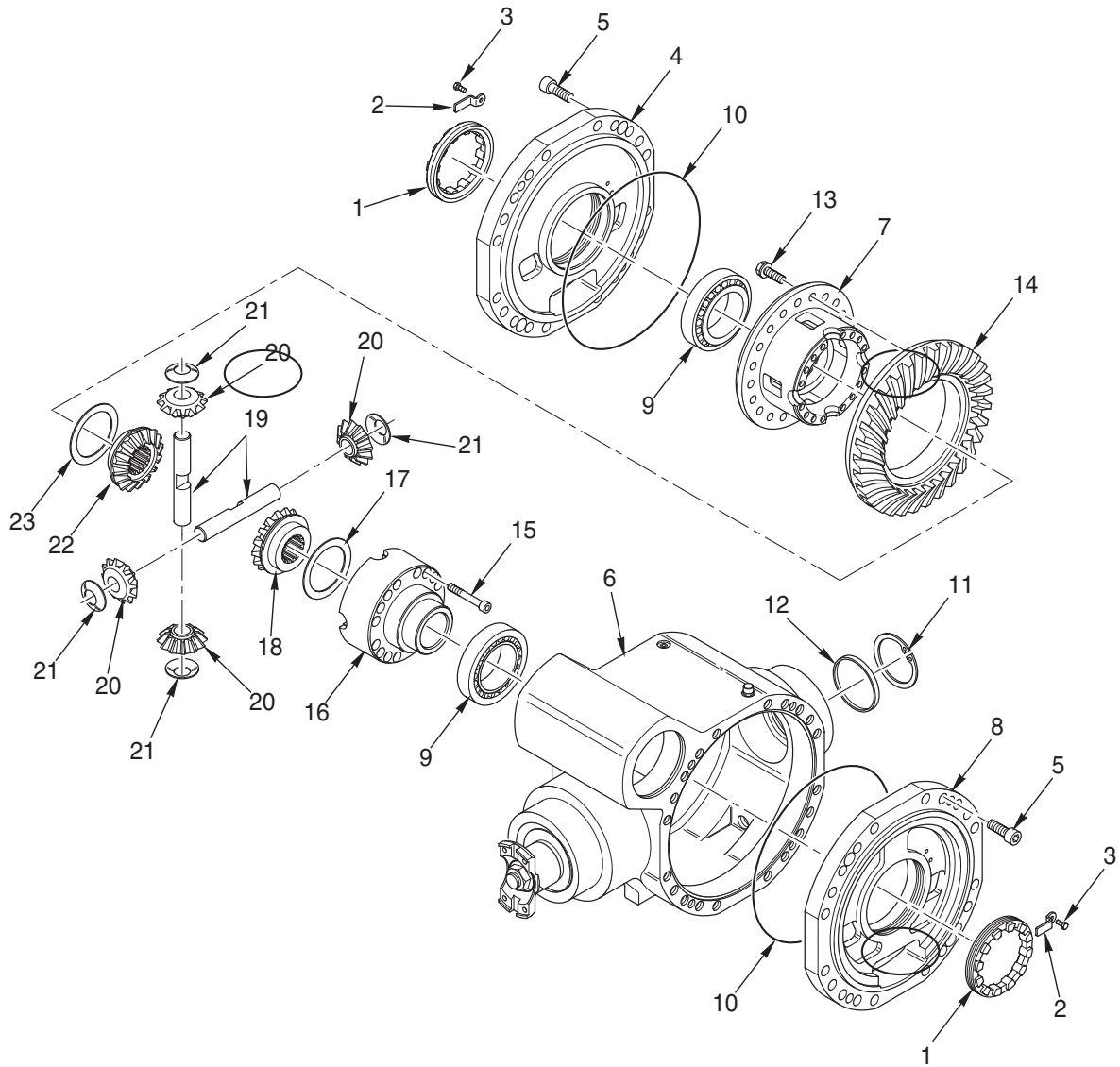

7409FAX331

Assembly

- (1) Install the shoulder ring (23) and planetary gear (22) into the half-box (7).

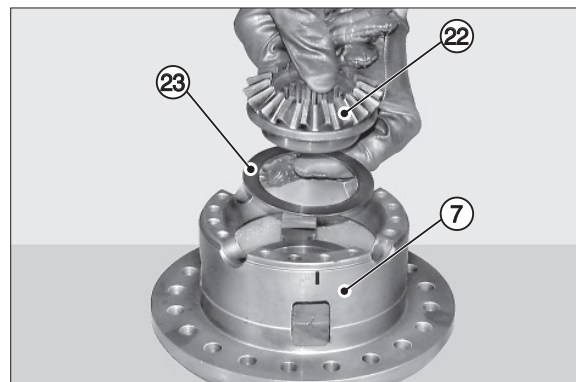

7409FAX332

- (2) Install the planetary gears (20) and spherical shoulder washers (21) onto the shafts (19).
Install the assemblies in the half-box (7).

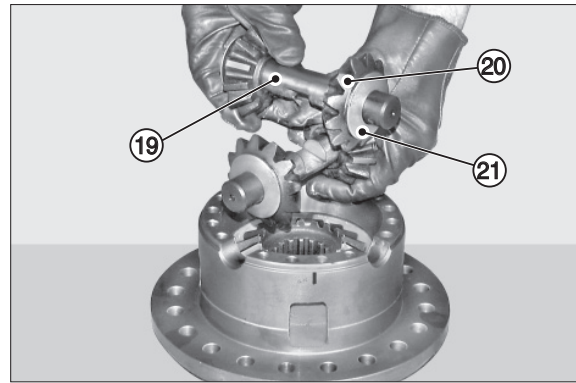

7409FAX333

- (3) Install the planetary gear (18) and shoulder ring (17).

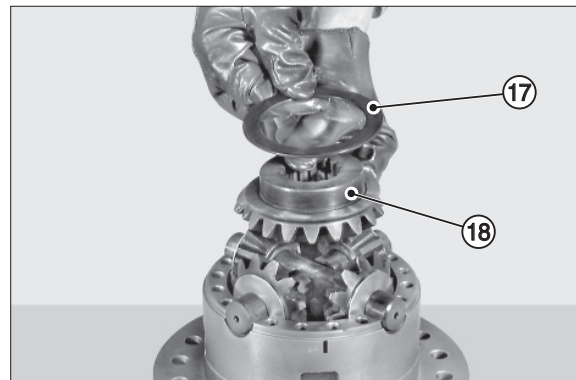

7409FAX334

- (4) Mount the locking half-box (16) onto the half-box (7) and lock it with screws (15) coated with loctite 270. Tighten provisionally by hand.

- ※ 1. The match marks on the two half-boxes must correspond.
- 2. Use only new screws.

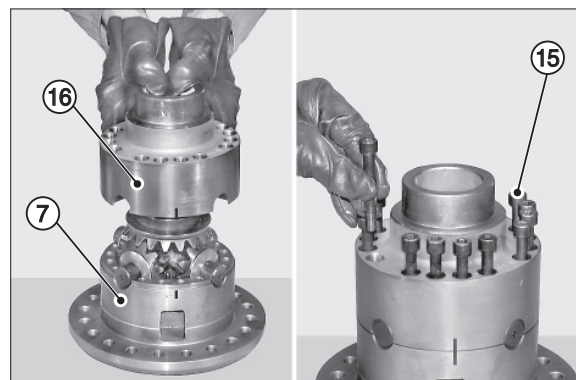

7409FAX335

- (5) Mount the gear ring (14) and fasten it to the differential box (7) with screws (13) tightened provisionally by hand.

- ※ Use only new screws.

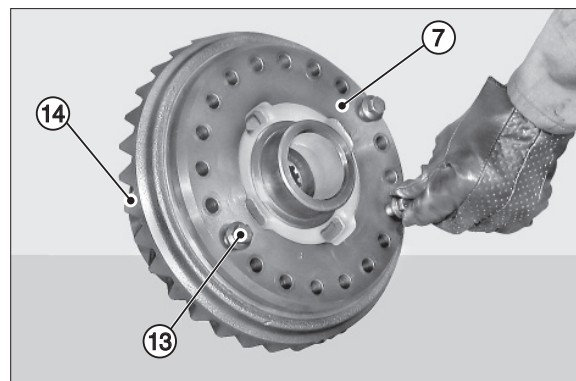

7409FAX336

- (6) Fit the complete differential unit in a vice and tighten the screws (15) holding the two half boxes together to a torque of 14.3~15.7 kgf · m (103~114 lbf · ft).

※ Tighten screws using the alternate and criss-cross method.

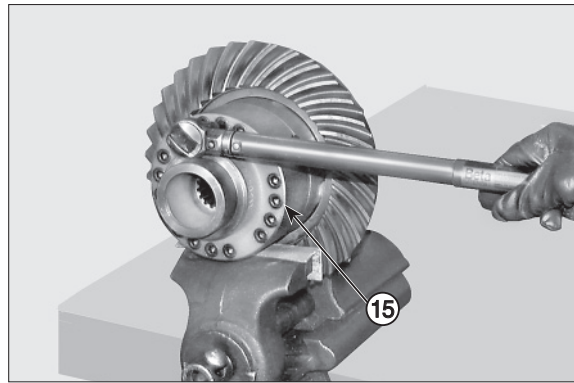

7409FAX337

- (7) Lock the gear ring (14) by tightening the screws (13) to a torque of 11.7~14.5 kgf · m (84.6~105 lbf · ft).

※ Use the alternate and criss-cross tightening method.

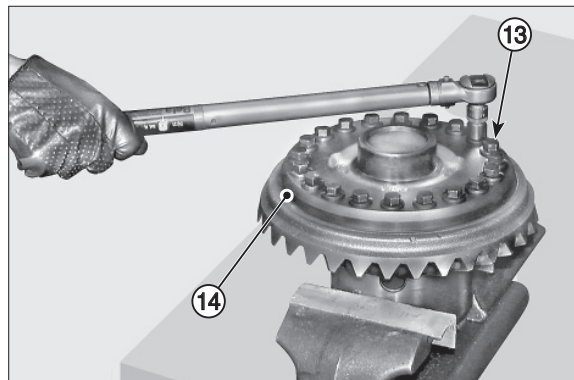

7409FAX338

- (8) Position the differential unit under a press and fit it with bearings (9) using tool T14.

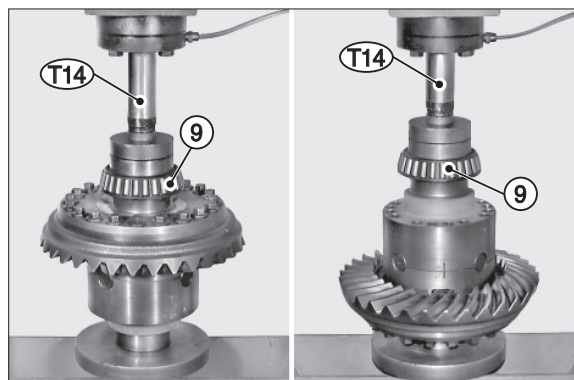

7409FAX339

Installation

※ If bearings (9) are replaced, introduce the thrust blocks into intermediate covers (4) and (8).

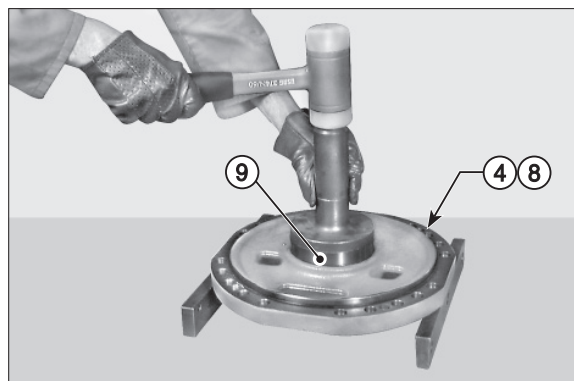

7409FAX340

(9) Fit the non-gear ring side of main body (6) complete of pinion with intermediate cover (8); lock cover with screws (5) coated with loctite 242 and with two service screws "V" (M16X50) tightened to the same torque. Tighten screws to a torque of 13.3~14.6 kgf · m (96.2~106 lbf · ft).

※ Check the state of the O-ring (10).

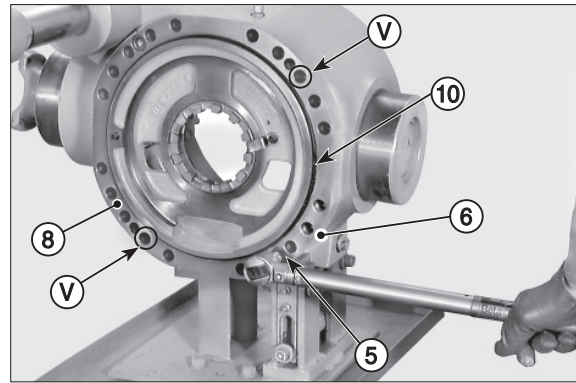

7409FAX341

(10) Using tool T13, position the differential unit (7) into the main body (6).

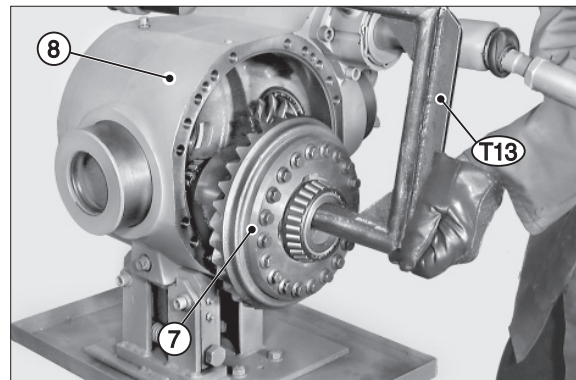

7409FAX342

(11) Tighten the two safety studs "C" into the main body (6) and install the intermediate cover (4).

Lock into position with screws (5) treated with loctite 242 and two service screws "V" (M16X50) locked to the same torque. Tighten screws to a torque of 13.3~14.6 kgf · m (96.2~106 lbf · ft).

※ Check the state of O-ring (10).

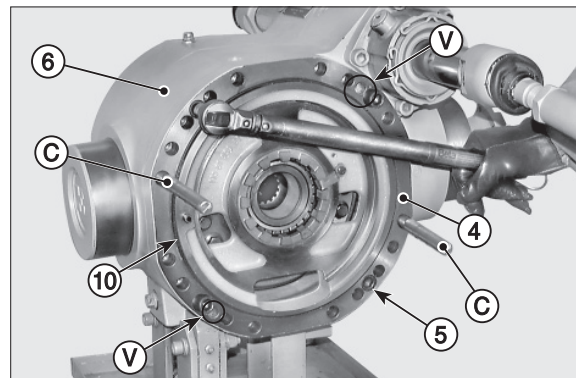

7409FAX343

4. REAR AXLE

1) SERVICE BRAKE DISASSEMBLY

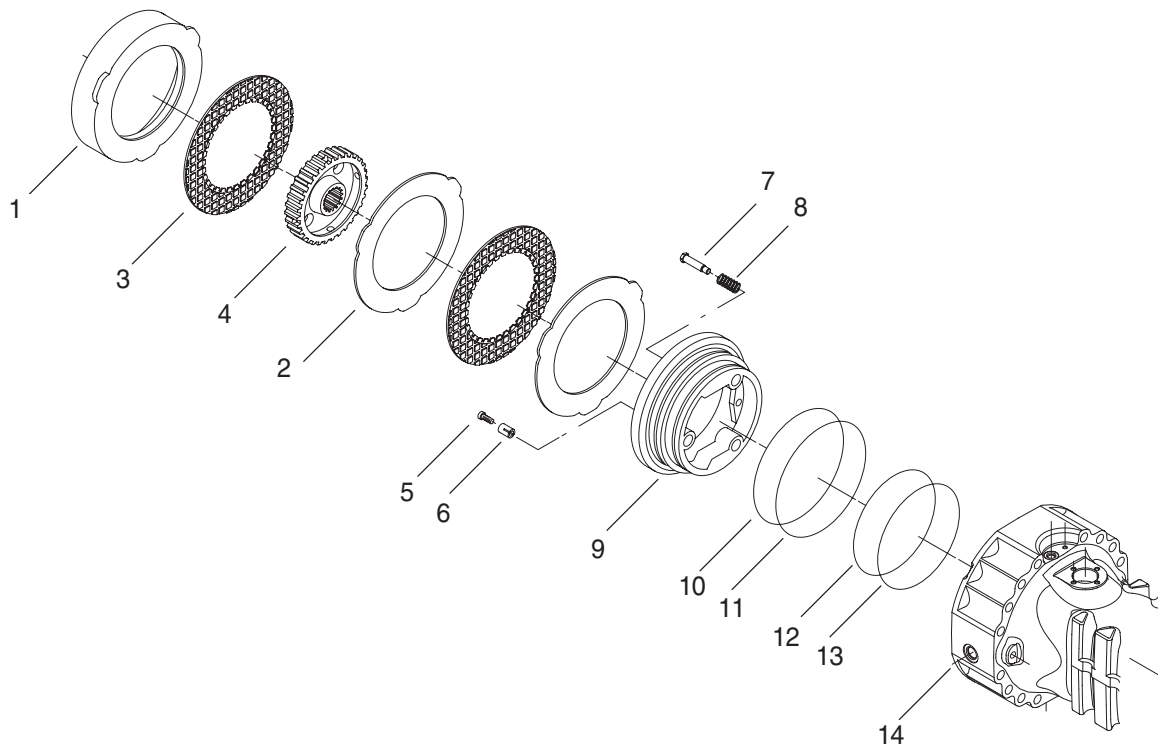

7409RAX001

- (1) Sling the arm to be removed and connect it to a hoist.
Loosen and remove screws.

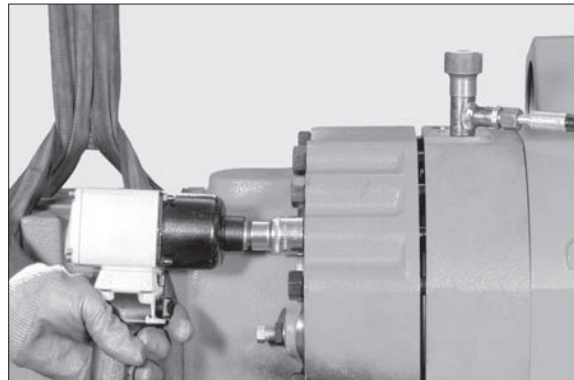

7409RAX002

- (2) Note down their order of assembly and remove the counterwasher (1).

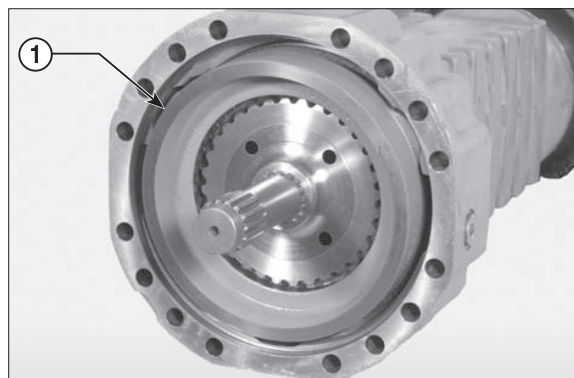

7409RAX003

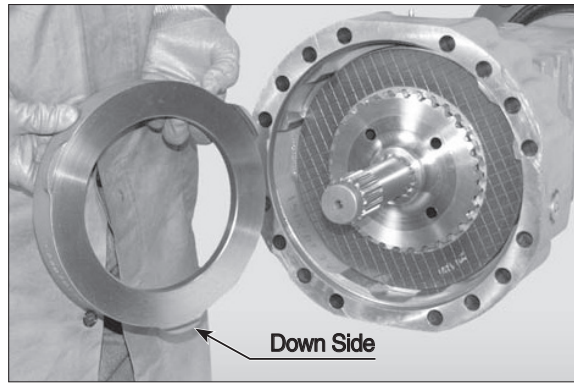

7409RAX004

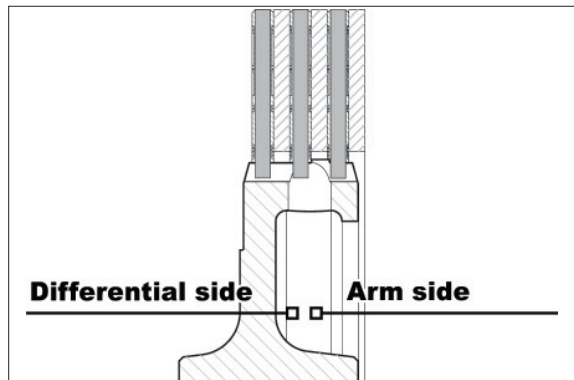

7409RAX005

(3) Remove braking discs (2)(3), noting down direction of assembly.

※ If disks are not to be replaced, avoid changing their position.

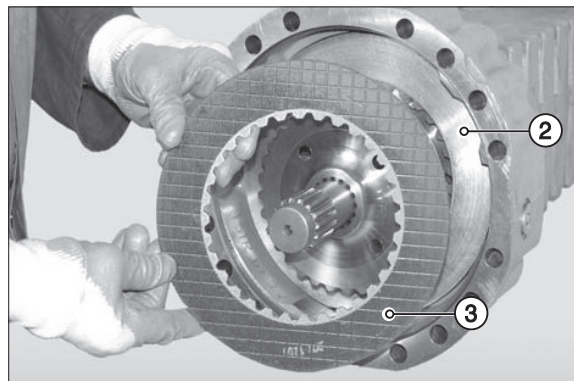

7409RAX006

(4) Remove the flange (4) complete with the discs.

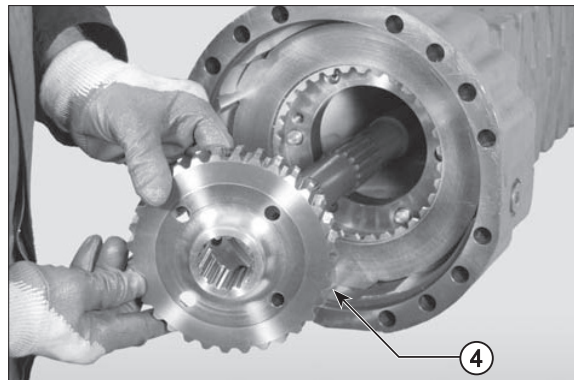

7409RAX007

(5) Noting down direction of assembly.

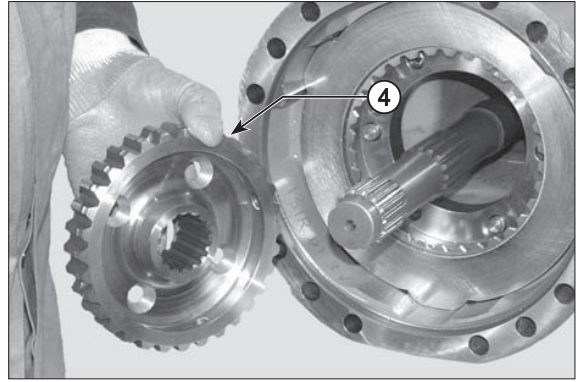

7409RAX008

(6) Remove braking discs, noting down direction of assembly.

※ If disks are not to be replaced, avoid changing their position.



7409RAX009

(7) Remove the reversal springs (7)

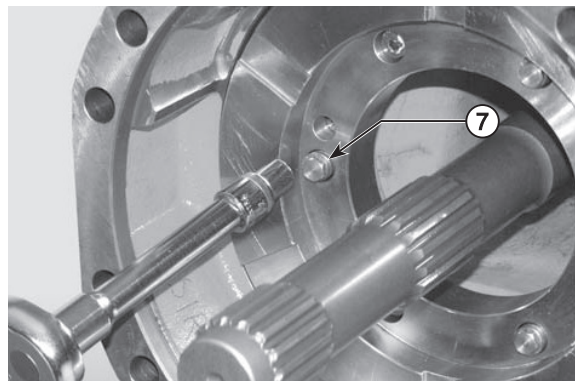

7409RAX010

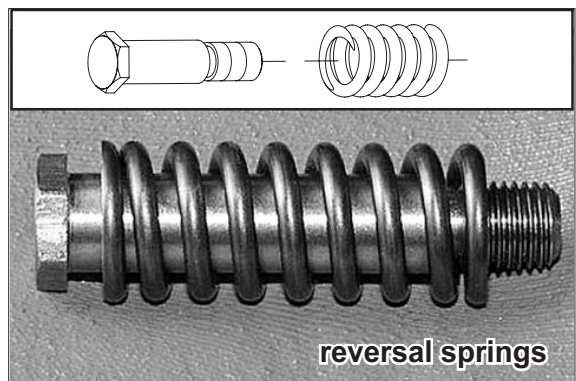

7409RAX011

(8) Remove the adjusting screws (5)

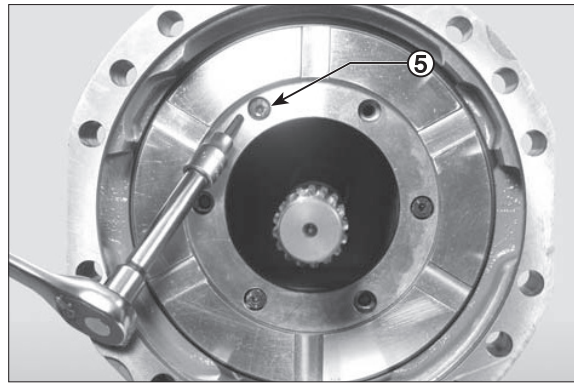

7409RAX012

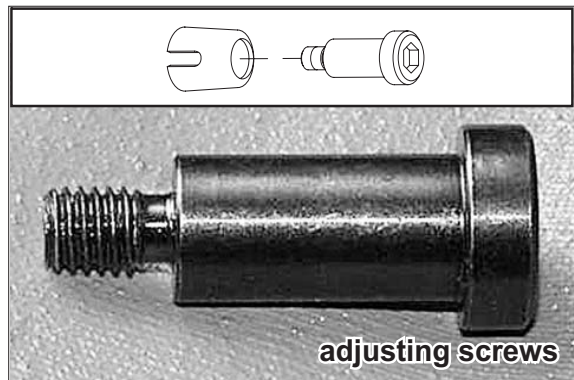

7409RAX013

(9) Slowly introduce low-pressure compressed air through the connection member for the service brake (P1), in order to extract the piston (9).

※ Hold the piston (9) back, as it may be suddenly ejected and damaged.

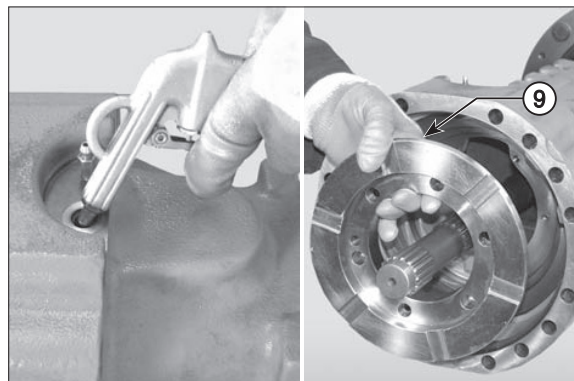

7409RAX014

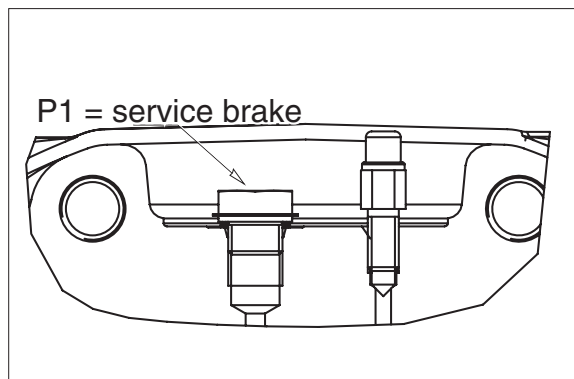

7409RAX015

2) SERVICE BRAKE ASSEMBLING

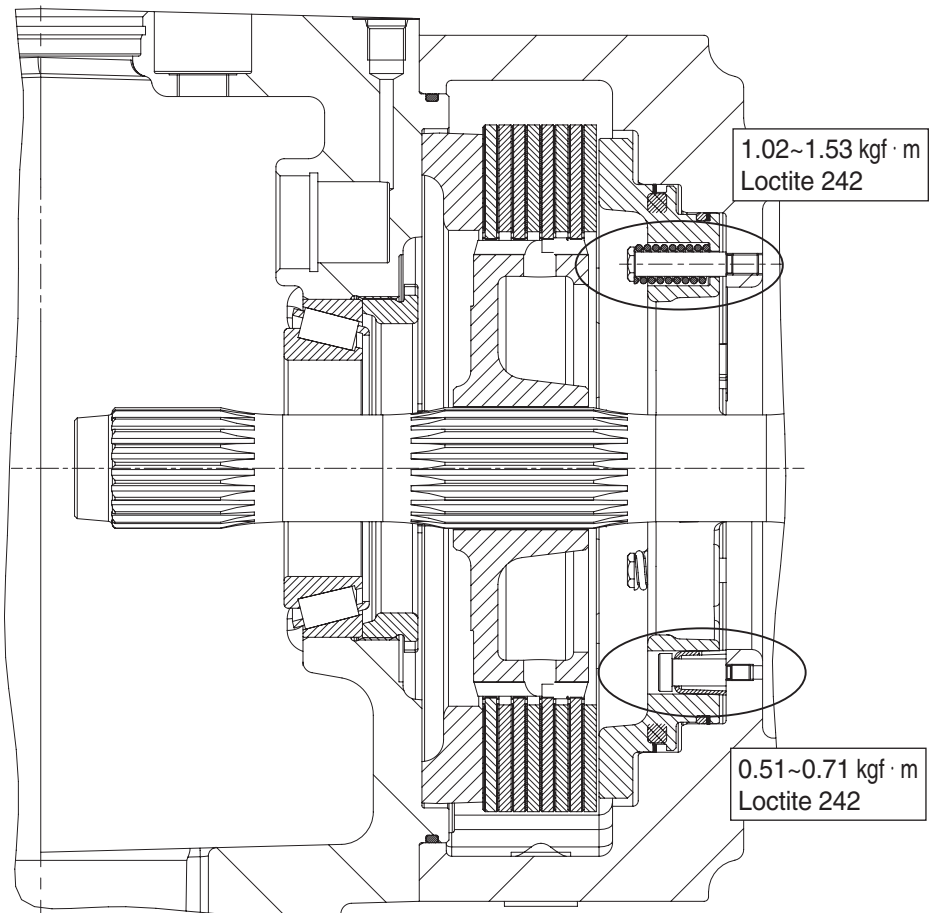

7409RAX016

- (1) Insert the stroke automatic regulation springs (6); place them in line with the piston (9).

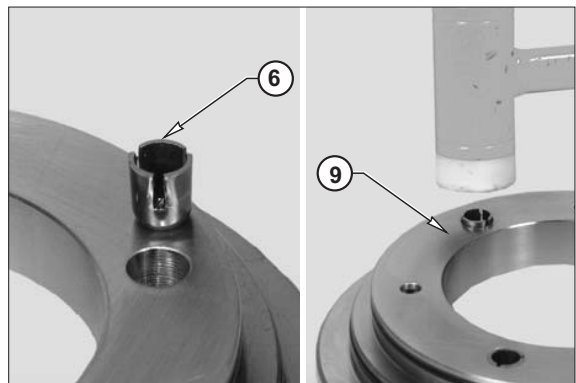

7409RAX017

- (2) Fit O-ring (11)(12) and back-up ring (10) (13) onto the piston (11).
Lubricate the piston and the O-rings and install the unit into the arm (14).

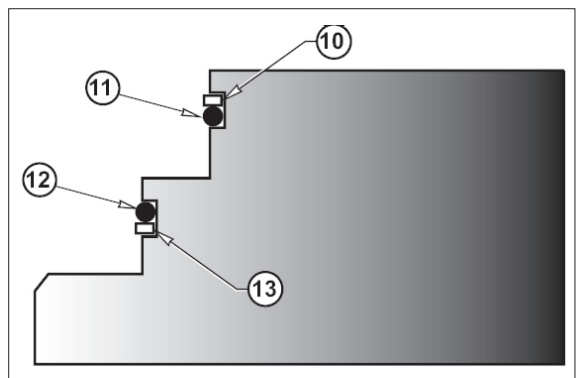

7409RAX018

(3) Using a plastic hammer, ram the piston (9) into the arm (14).

※ Lightly hammer all around the edge in an alternate sequence.

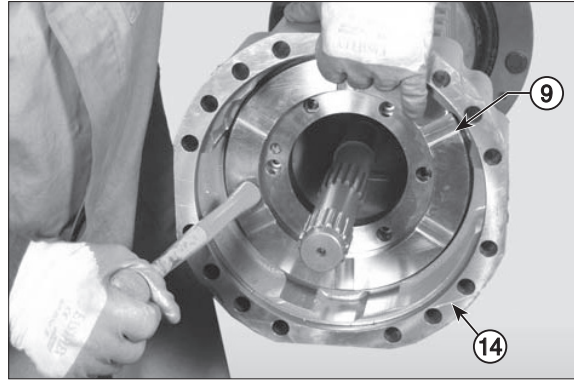

7409RAX019

(4) Fit the reversal springs (7) on the piston (9).

Apply loctite 242 to the thread of the adjustment screw.

Tighten with torque wrench setting of 0.51~0.71 kgf · m (3.69~5.14 lbf · ft).

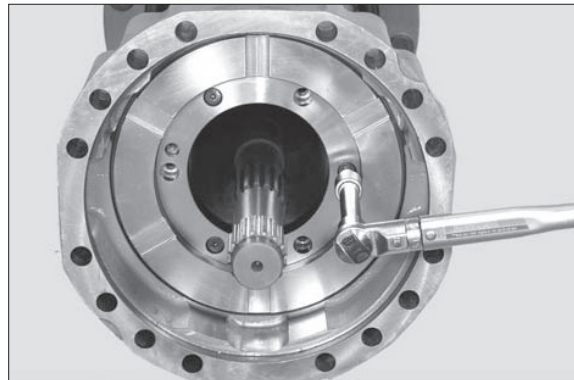

7409RAX020

(5) Fit the adjusting screws (5).

Apply loctite 270 to the thread.

· Torque wrench setting :
0.51~0.71 kgf · m (3.69~5.14 lbf · ft)

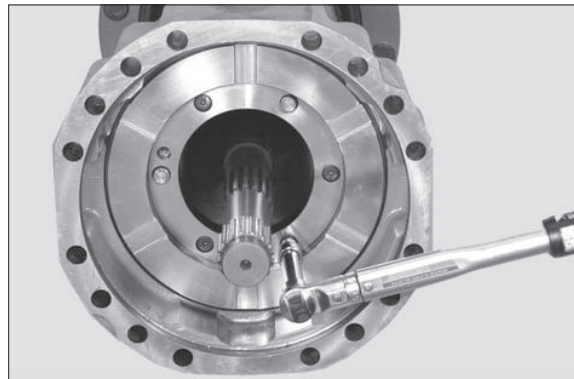

7409RAX021

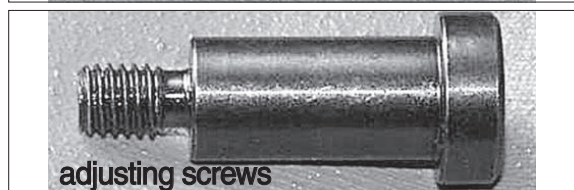
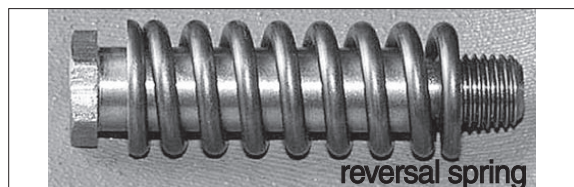

7409RAX022

(6) Insert the brake discs in the right sequence.

※ The first brake disc (2) to be inserted must be of metal material.

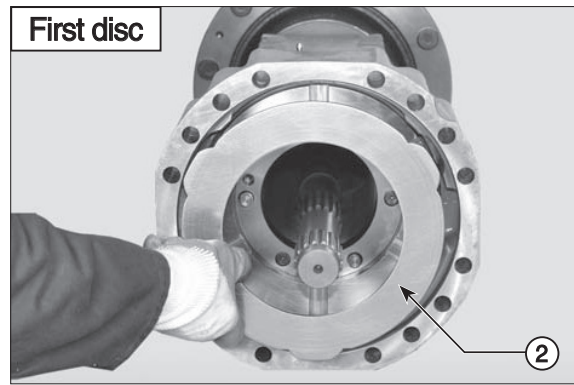

※ The second brake disc (3) to be inserted must be of friction material.

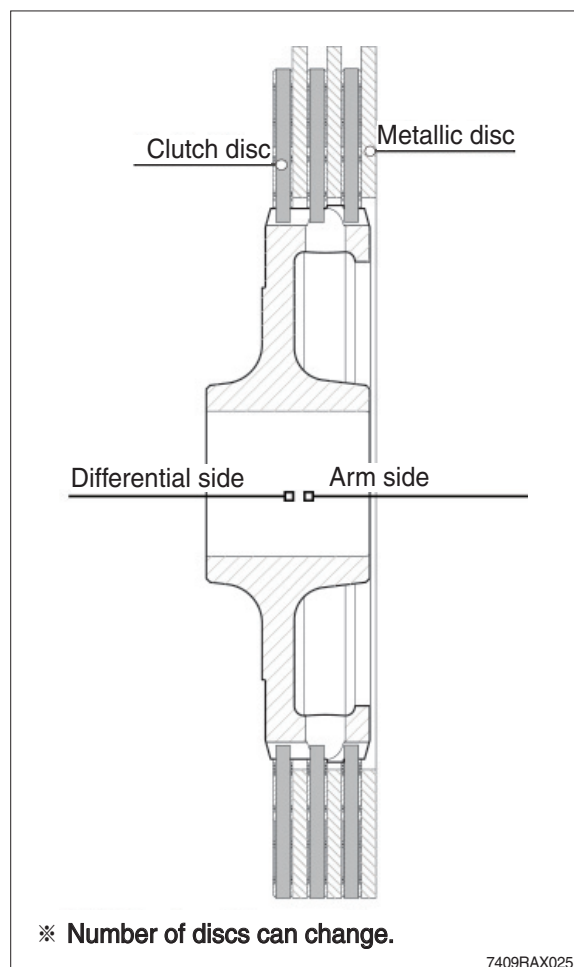
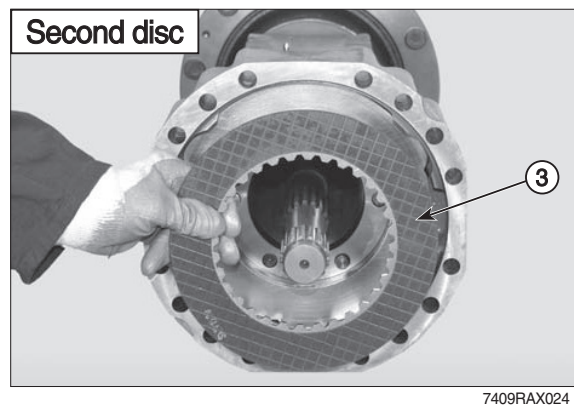

(7) Install the flange (4) on the arm.

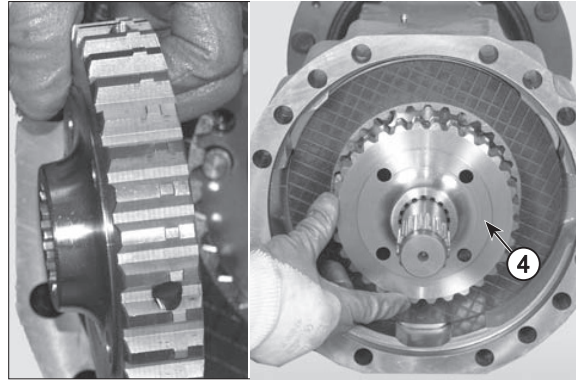

7409RAX026

(8) Insert the brake discs (2)(3) in the right sequence.

※ The last brake disc to be inserted must be of friction material.

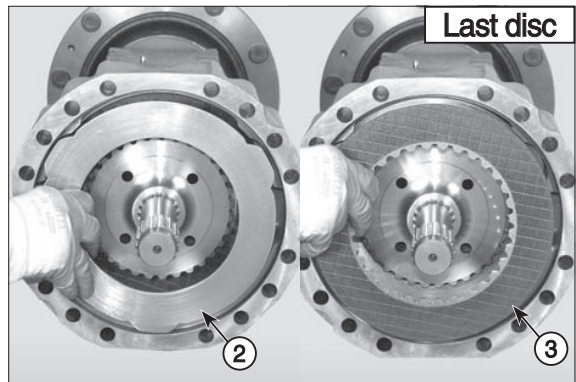

7409RAX027

(9) Insert the intermediate disk (1).

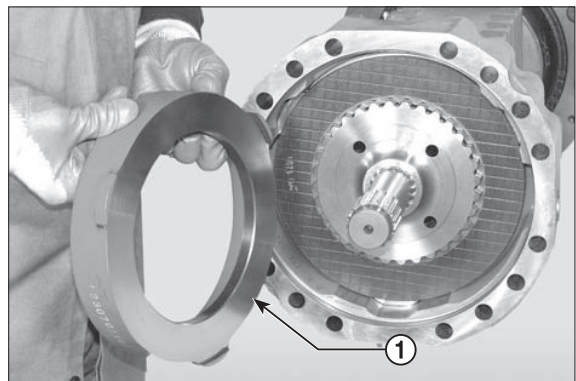

7409RAX028

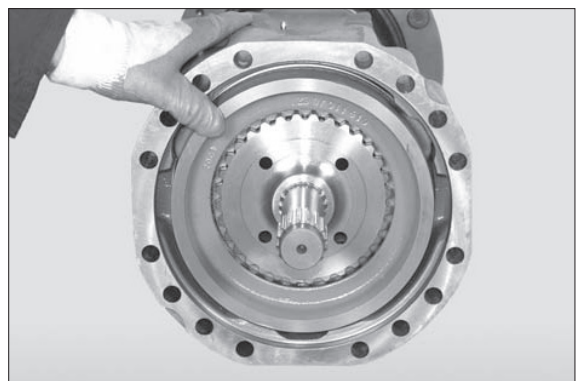

7409RAX029

(10) Check integrity and position of the cylinder's O-ring.

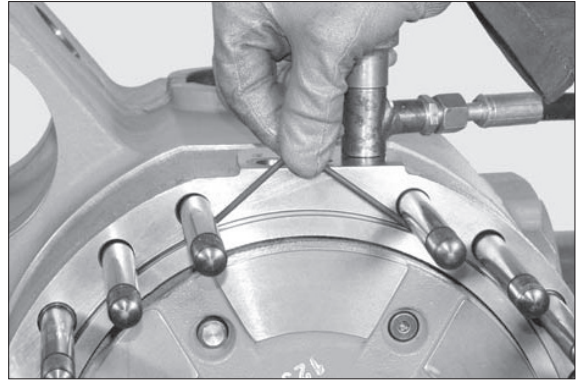

7409RAX030

(11) Cross tighten the nuts in two stages.

- Torque wrench setting :
20.4~22.5 kgf · m (148~163 lbf · ft)

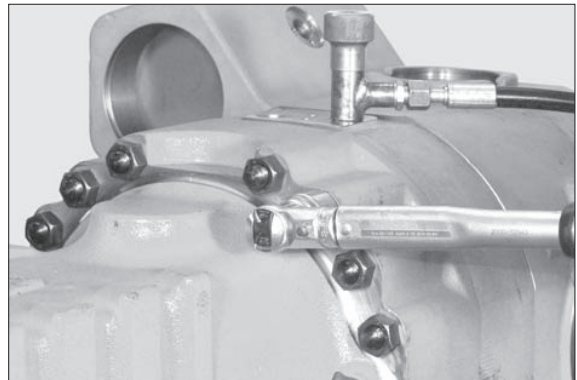

7409RAX031

3) HOW TO DISASSEMBLE THE PLANETARY REDUCTION

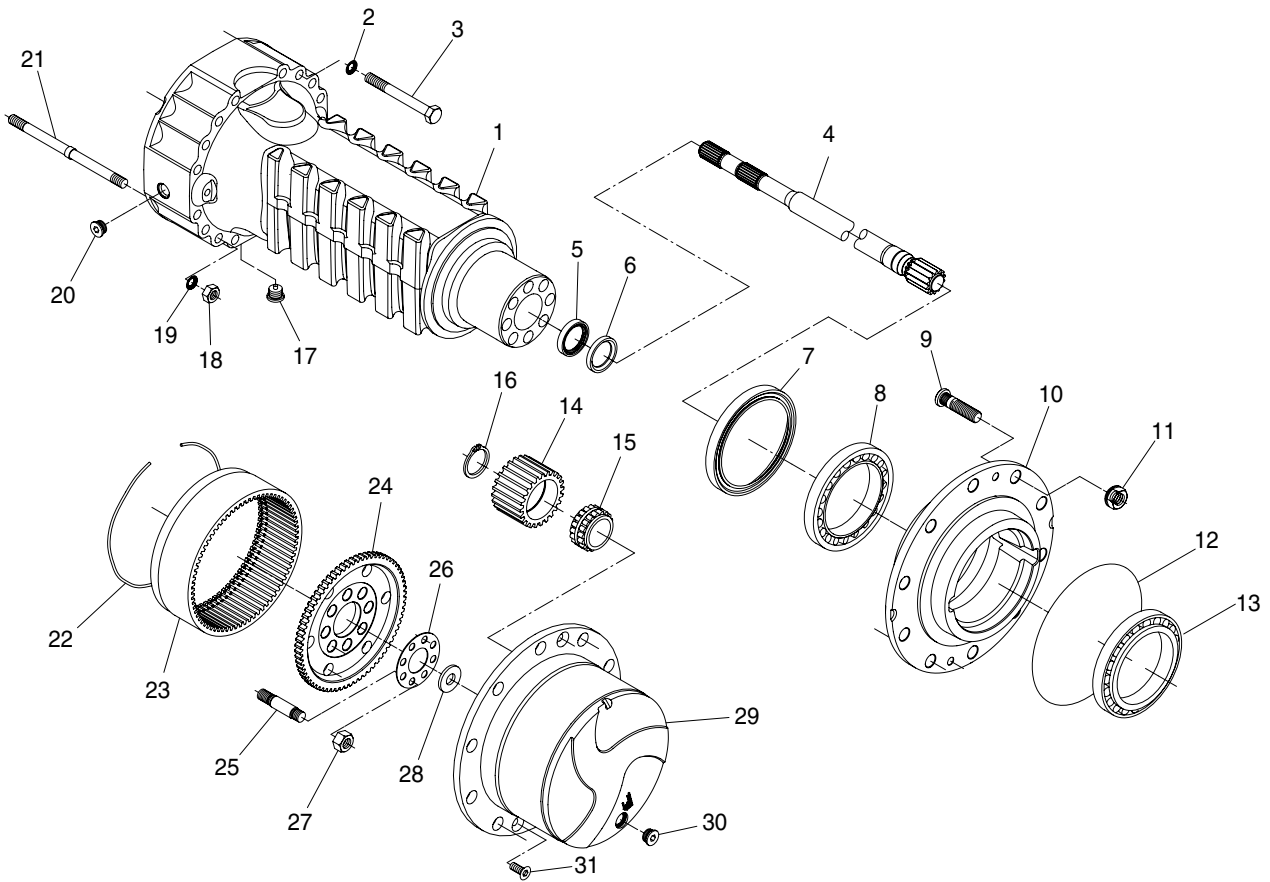

7409RAX032

(1) Remove oil-level plug (30) and the oil.

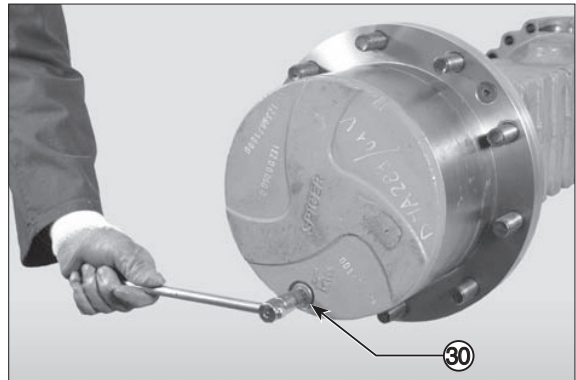

7409RAX033

(2) Remove the locking screws (31) of planetary cover (29).

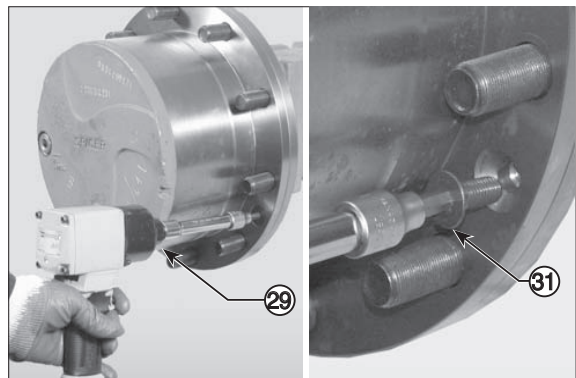

7409RAX034

- (3) Using two screwdrivers or two levers inserted in the slots provided, pry the planetary cover (29) away from the wheel hub (10).

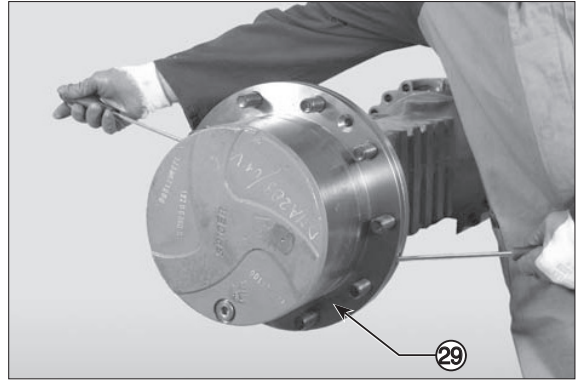

7409RAX035

- (4) Remove the cover (29).

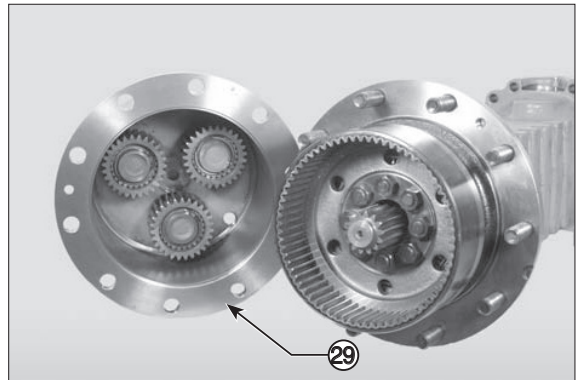

7409RAX036

- (5) Remove the axle half shaft (4).

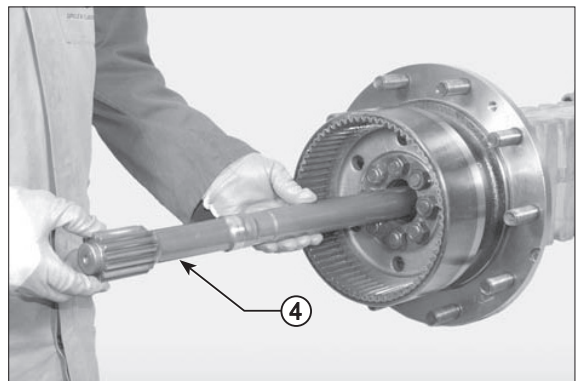

7409RAX037

- (6) Remove the safety spring rings (16) of the planetary gears (14).

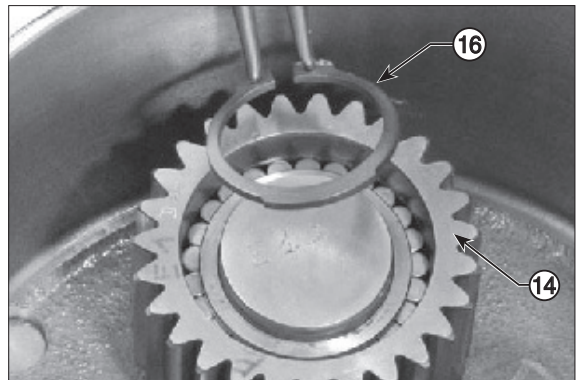

7409RAX038

(7) Remove the planetary gears (14).

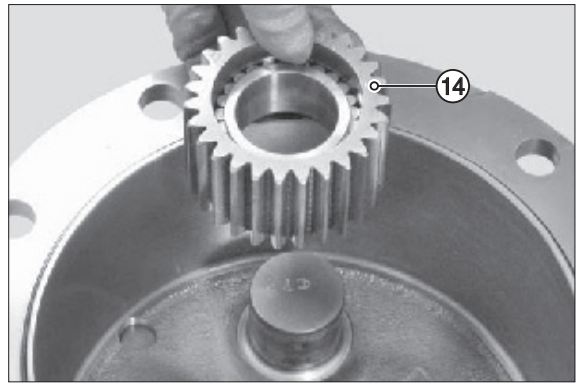

7409RAX039

※ Note down direction of assembly of planetary gears.

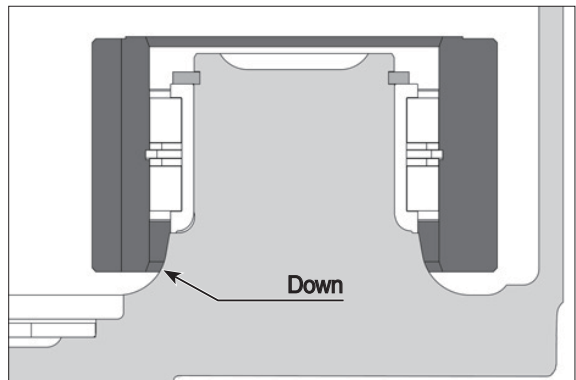

7409RAX040

(8) Check the wear of the shim washer (28) .

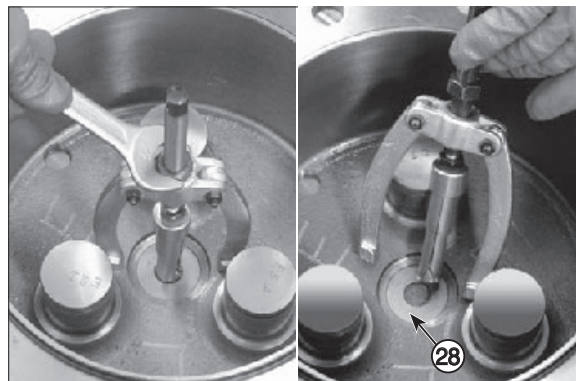

7409RAX041

(9) Accurately check the O-ring (22).

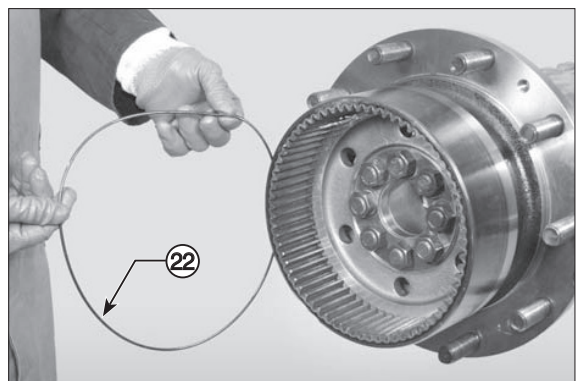

7409RAX042

(10) Loosen the nuts (27) and remove them.

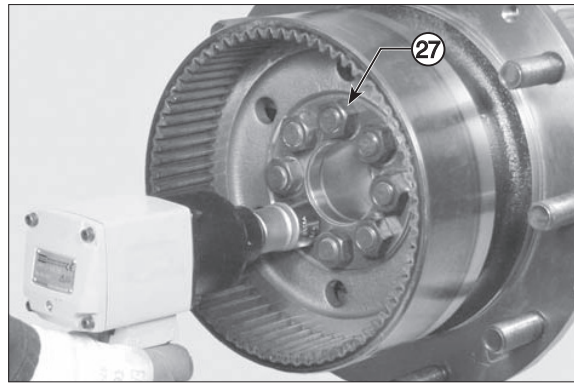

7409RAX043

(11) Remove the safety flange (26).



7409RAX044

(12) Using an extractor and applying a counter pressure to the screws (25), disengage the crown wheel (23) from the hub (10).

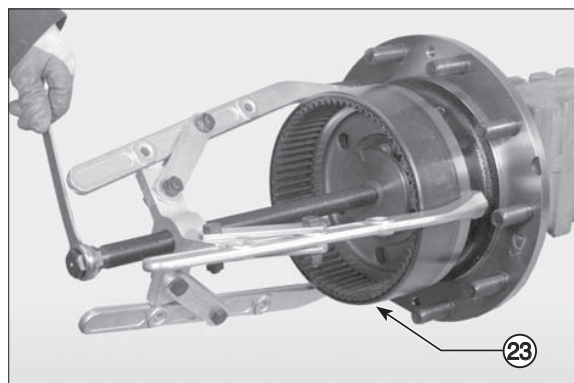

7409RAX045

(13) Remove the crown (23).

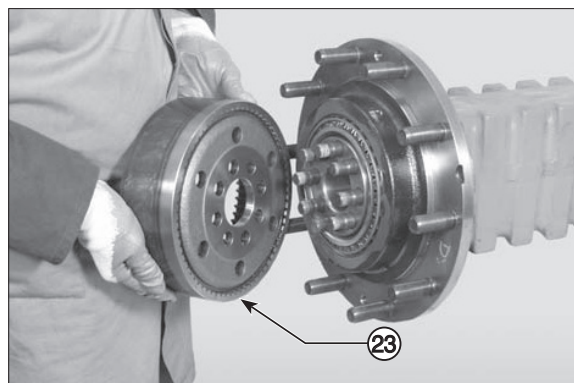

7409RAX046

(14) With the help of a hammer, shift the hub (10) and the external bearing (13).

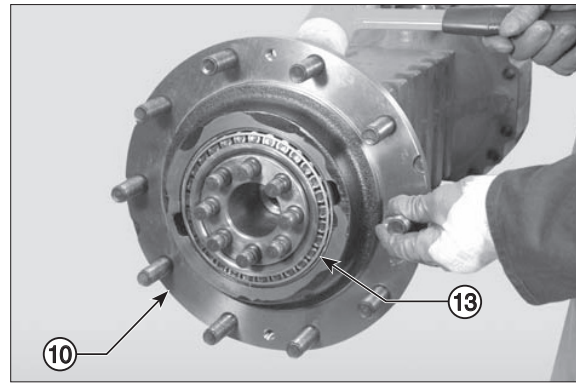

(15) Extract the external bearing (13).

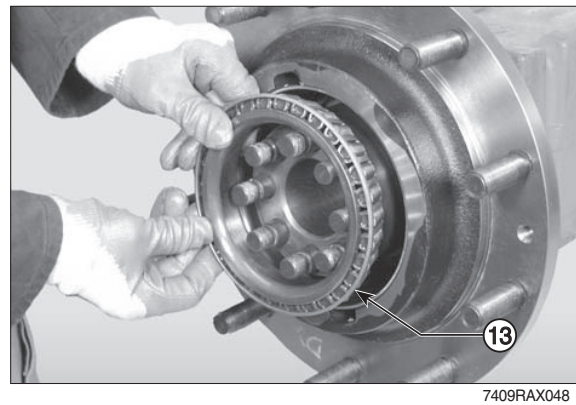

(16) Using an extractor and applying a counter pressure to the screws disengage the hub (10).

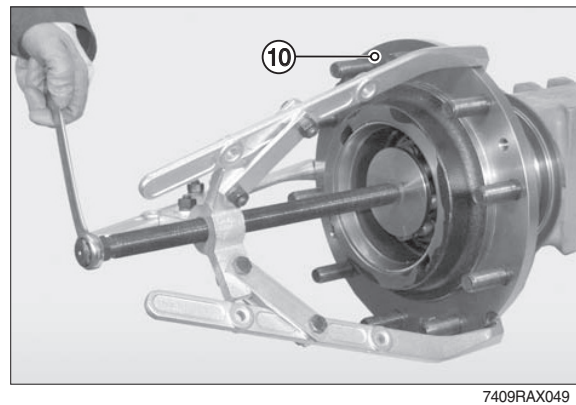

(17) Remove the internal bearing (8) and the hub (10).

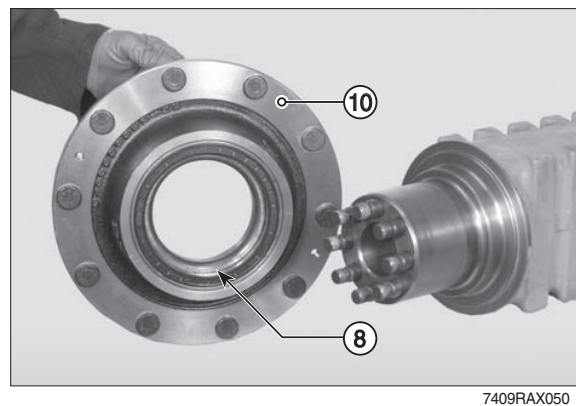

(18) Remove the seal ring (7) from the hub (10).

※ Note down direction of assembly.

※ The seal ring may not be reused.

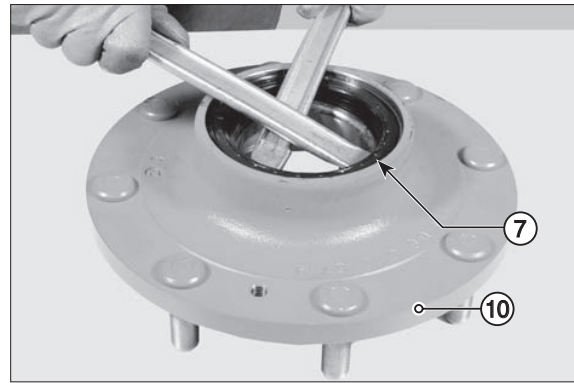

7409RAX051

(19) Remove the internal bearing (8) and sealing ring (7).

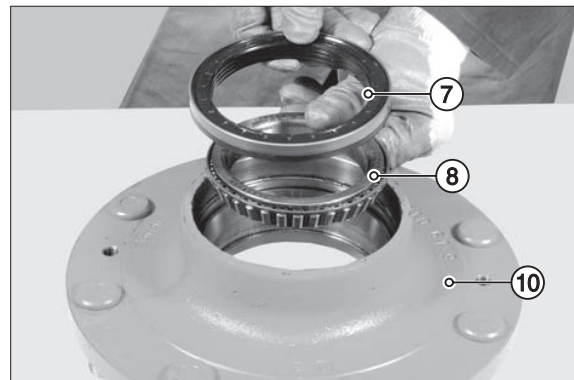

7409RAX052

(20) Remove the external thrust blocks of bearings, using a pindriver.

※ Hammer in an alternate sequence to prevent crawling and deformation of the thrust blocks.



7409RAX053

(21) Remove the external thrust blocks of bearings, using a pindriver.

※ Hammer in an alternate sequence to prevent crawling and deformation of the thrust blocks.



7409RAX054

(22) Using an extractor, remove seal ring (5) and guide ring(6).

※ Note down the direction of assembly of snap ring.

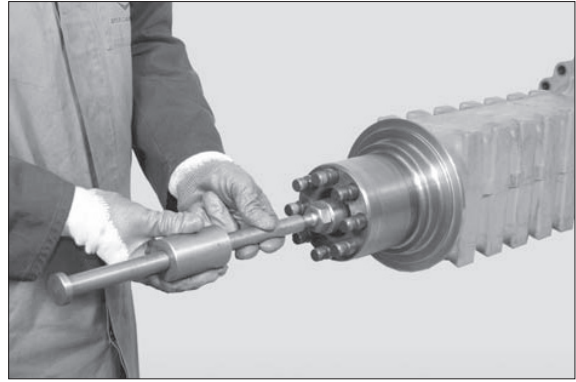

7409RAX055

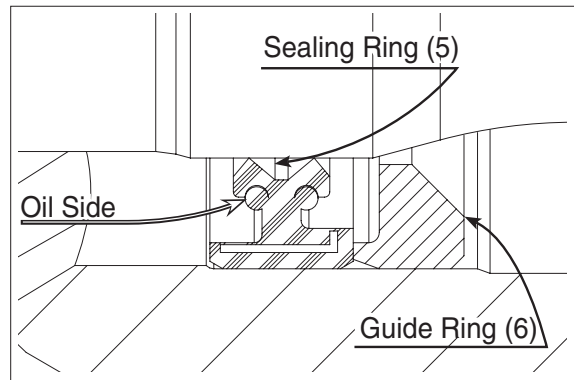

7409RAX056

4) ASSEMBLING THE PLANETARY REDUCTION

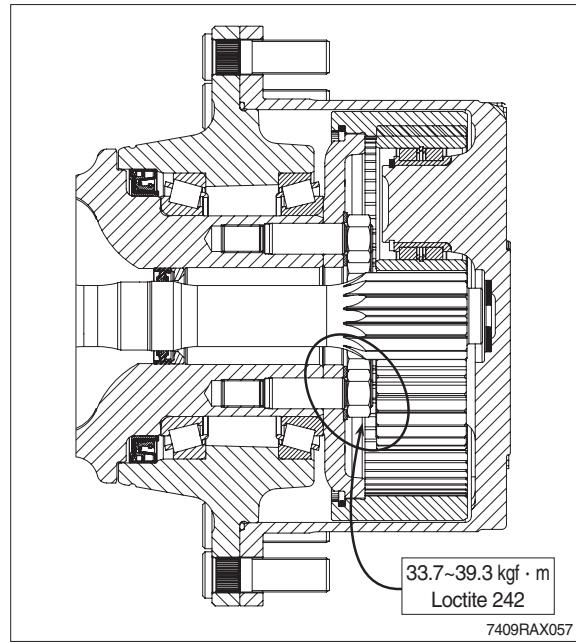

- (1) Lubricate and fit the seal ring (5) and guide ring(6) onto tool T3; install the rings into the arm.

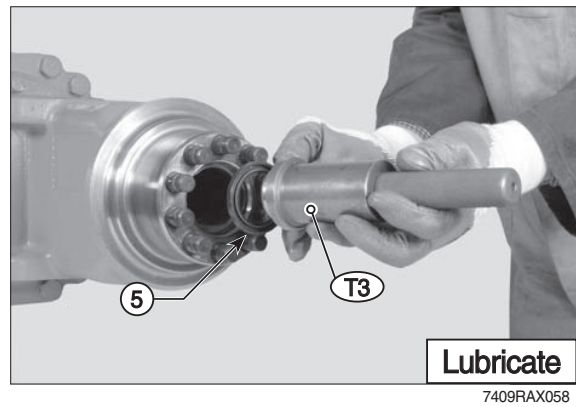

- ※ Pay particular attention to the direction of assembly of the rings.

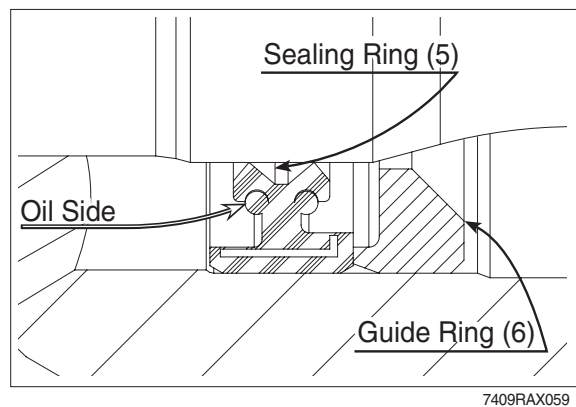

- (2) Position the lower part of tool T1 and the thrust block of the external bearing (13).

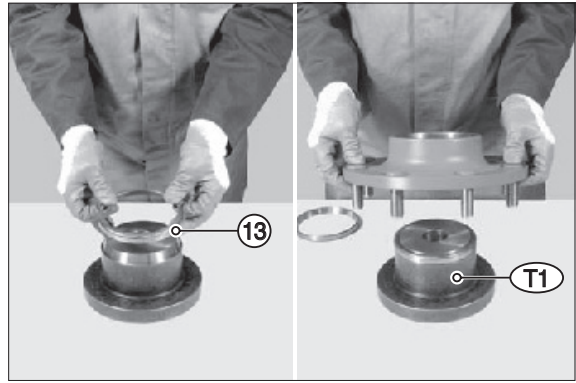

- (3) Lubricate the seats of the bearings and position the hub (10) on tool T1; position the thrust block of the internal bearing (8).

※ Check that the thrust block is correctly oriented.

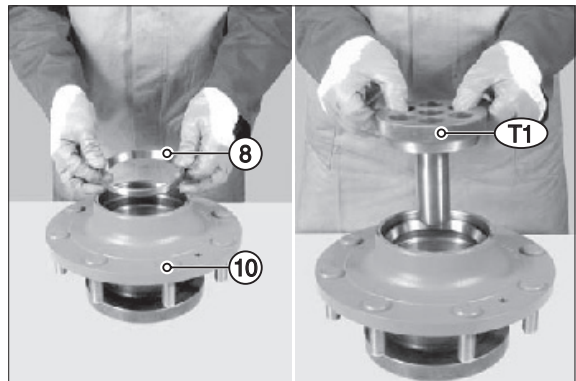

- (4) Fit the bearing (8) and seal ring (7) into the internal thrust block.

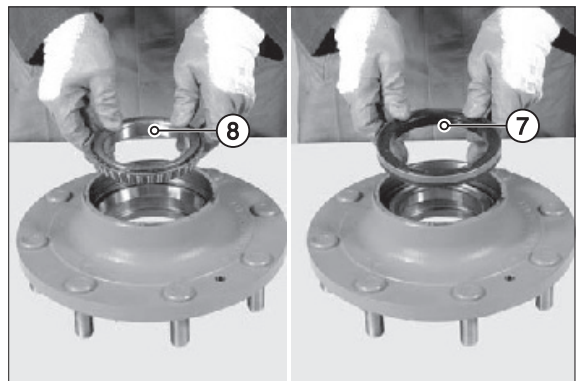

- (5) Using special tool apply a repositionable jointing compound for seals to the outer surface of the sealing ring (7). Position the sealing ring (7) in the hub (10).

※ Check that the ring (7) is correctly oriented.



(6) Install the wheel hub.

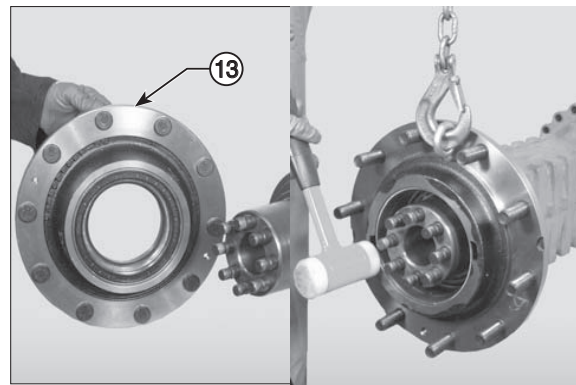

7409RAX064

(7) Install the external bearing (13).

- ※ Move the bearing to the limit stop by hammering lightly all around the edge.

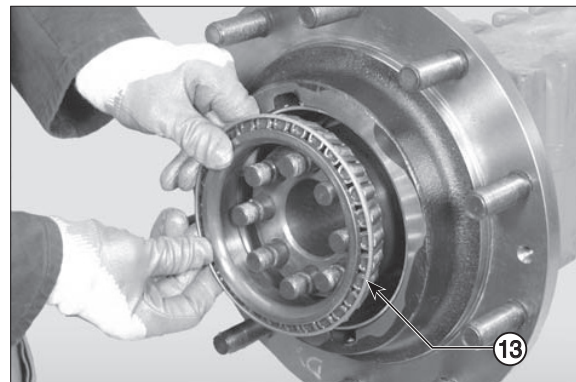

7409RAX065

(8) Install the crown wheel (23).

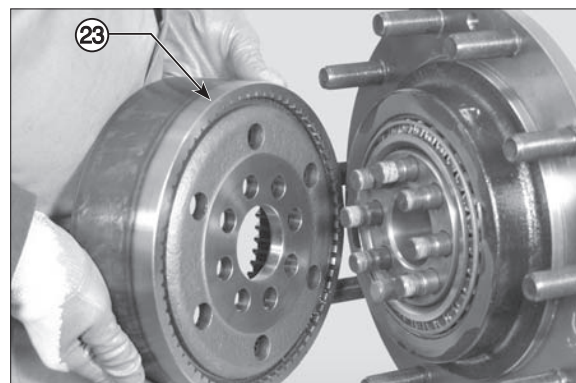

7409RAX066

(9) Fit the complete crown flange (23).

- ※ In order to fasten the flange (23), use a plastic hammer and alternately hammer on several equidistant points.

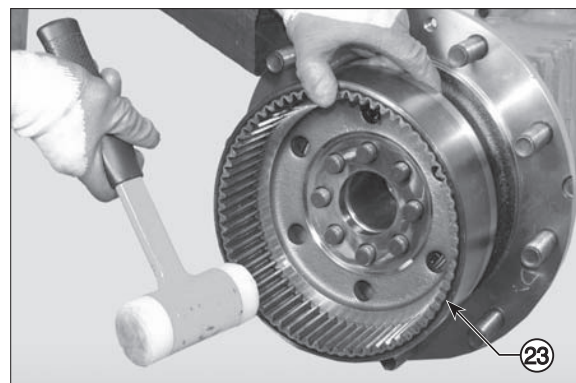

7409RAX067

- (10) Install the security flange (26).
Using grease the surface of the safety flange (26) that touches the crown wheel.

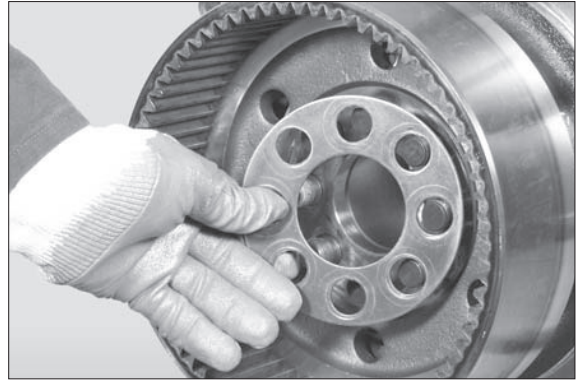

7409RAX068

- (11) Coat the nuts (27) with loctite 242 and screw them.
Tighten nuts (27) in two stages, using the criss-cross method.

- Initial torque wrench setting :
33.7 kgf · m (244 lbf · ft)
- Final torque wrench setting :
39.3 kgf · m (284 lbf · ft)

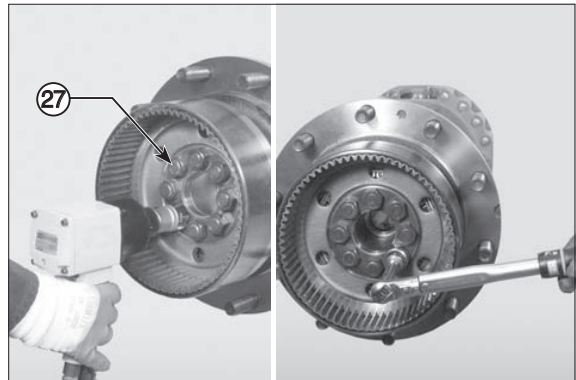

7409RAX069

- ※ Check the condition and position of the O-ring (12).

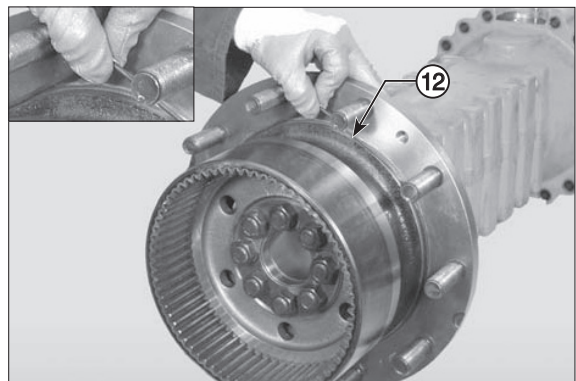

7409RAX070

- (12) Fit shim washer (28) into spider cover (29).

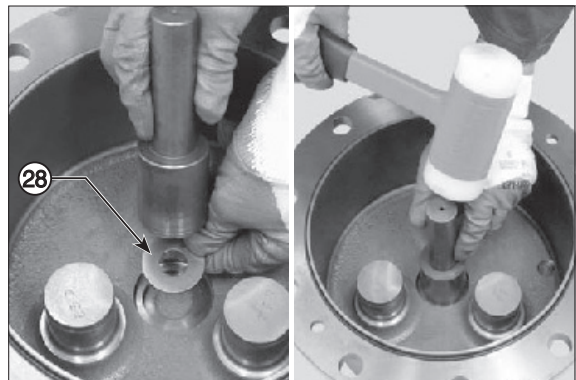

7409RAX071

- (13) Insert the planet wheel gears (14) into the cover (29).
Lock gears (14) into position by installing the snap rings.

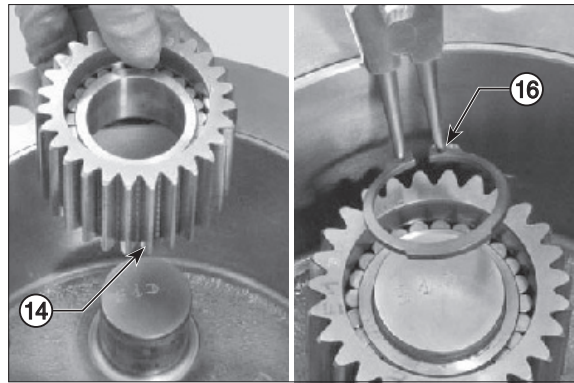

7409RAX072

- (14) Accurately check the orientation.

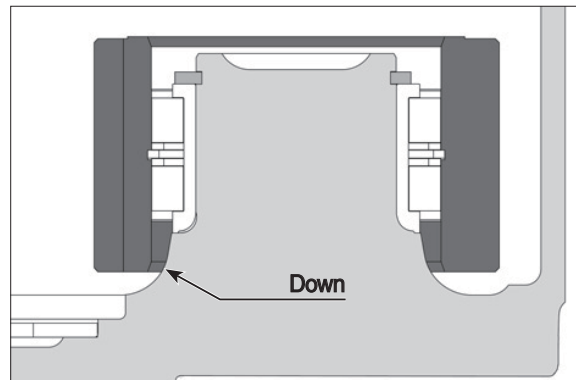

7409RAX073

- (15) Fit the planetary carrier cover onto the hub.
※ Check that the O-ring is in good condition and in position.

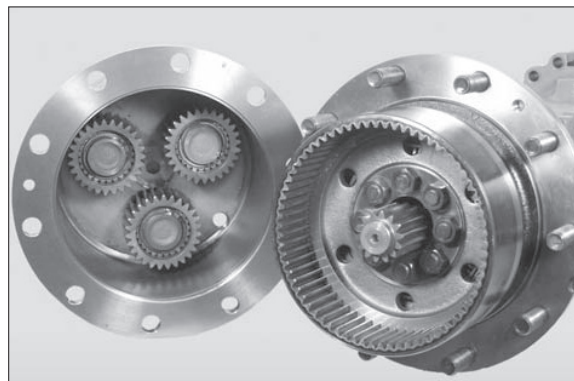

7409RAX074

- (16) Lock the planetary carrier cover by tightening the screws.

- Torque wrench setting for screws :
3.57~5.1 kgf · m (25.8~36.9 lbf · ft)

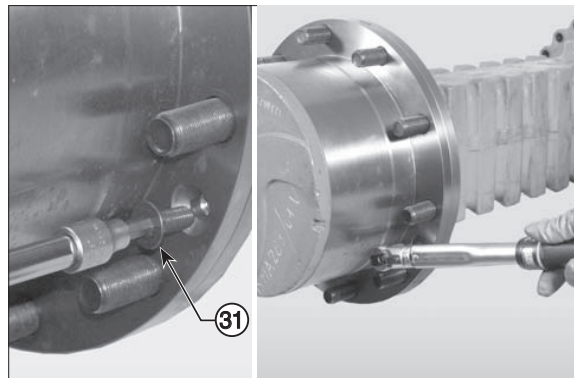

7409RAX075

5) HOW TO REMOVE AND DISASSEMBLE THE DIFFERENTIAL UNIT

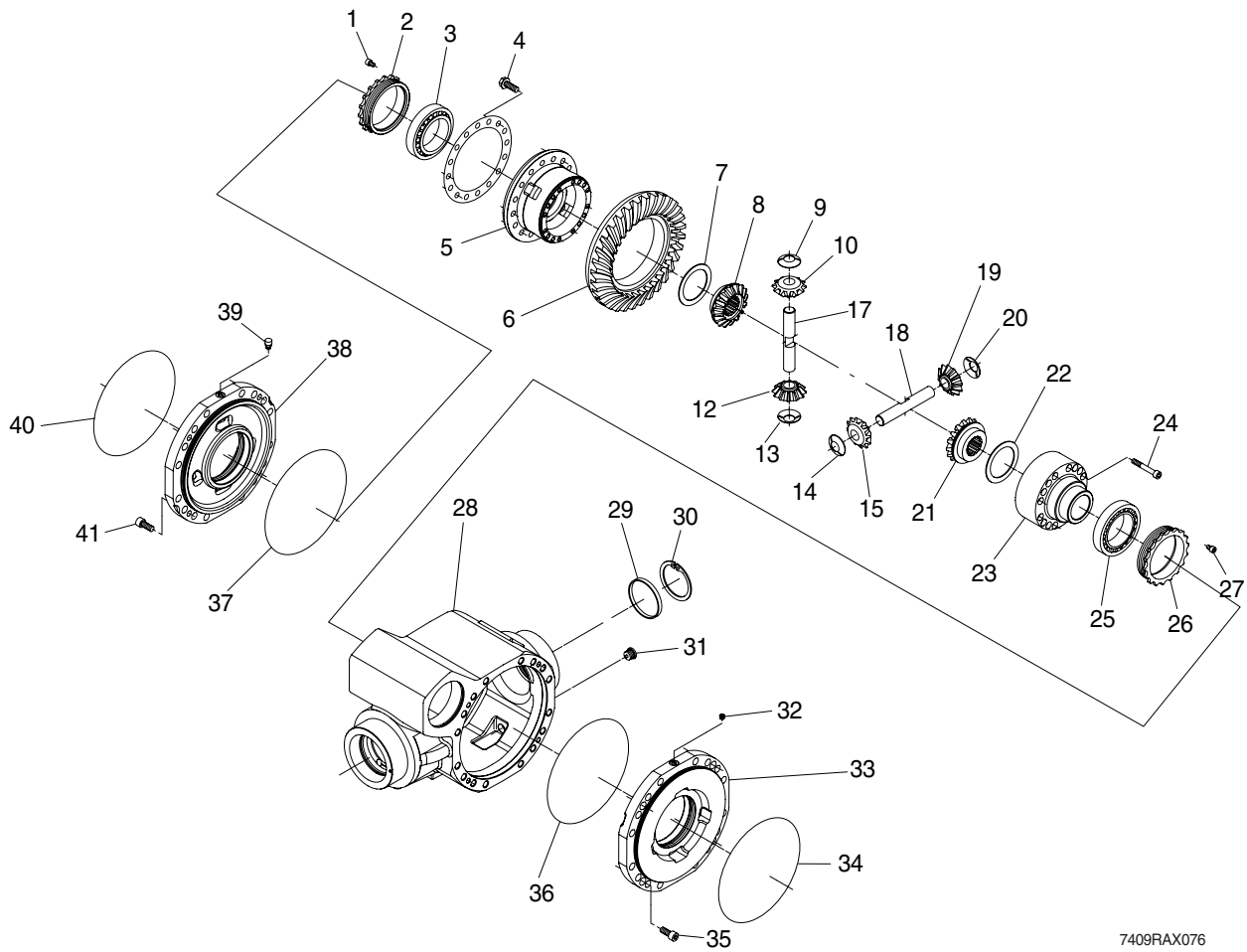

7409RAX076

- (1) Sling the arm to be removed and connect it to a hoist.
Loosen and remove screws and nuts.

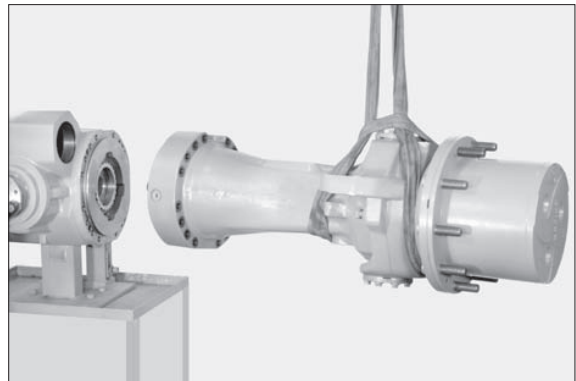

7409RAX077

- (2) Only if need removing or adjusting.
Remove the screw (27).

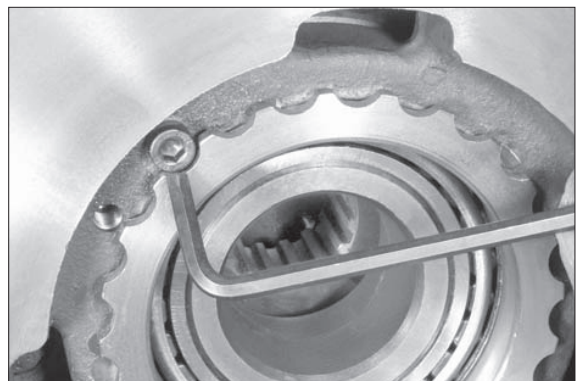

7409RAX078

- (3) Only if need removing or adjusting.
Uniformly heat the ring nuts up to a temperature of 80°C.

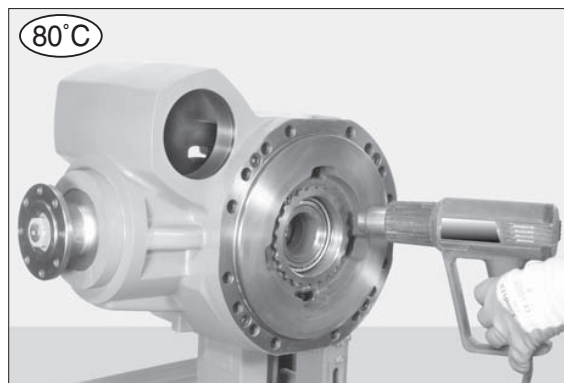

7409RAX079

- (4) Only if need removing or adjusting.
Using special tool T4 mark the position of the ring nuts (2) (26).

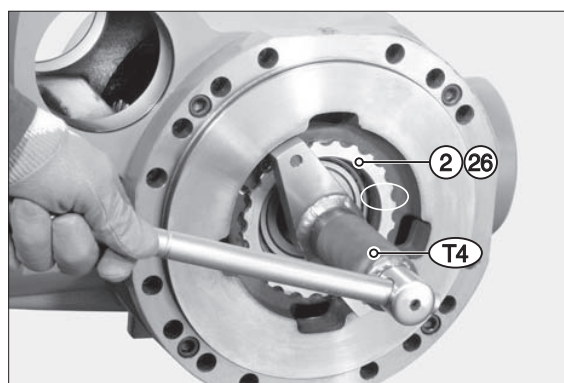

7409RAX080

- (5) Loose he stud bolts (35)(41) and remove two of them.

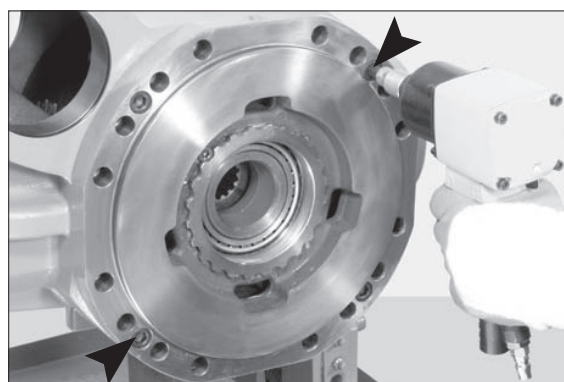

7409RAX081

- (6) Disjoin the cover (38)(33) crown side.

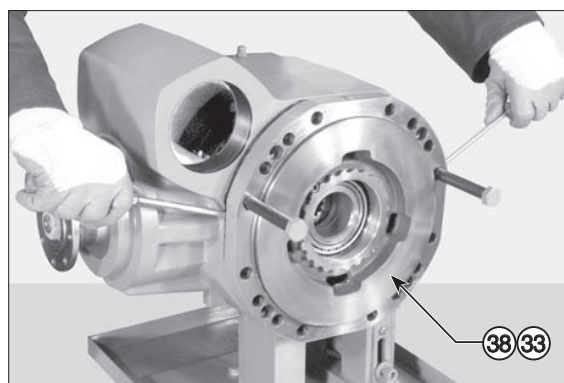

7409RAX082

(7) Remove the cover and studs.

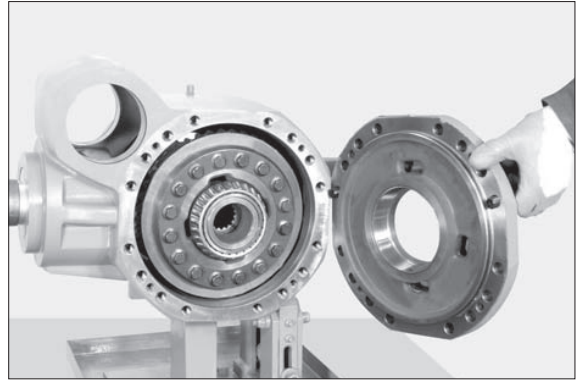

7409RAX083

(8) Extract the whole differential unit.

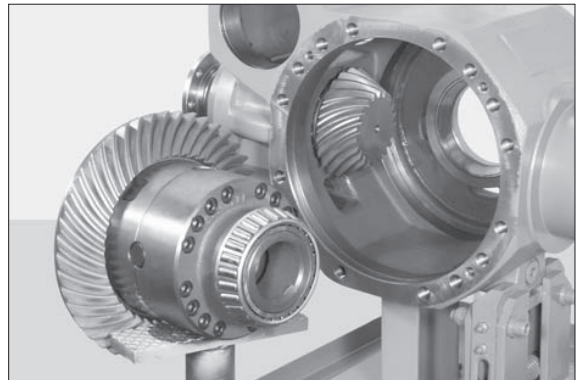

7409RAX084

(9) Remove the snap ring (30).

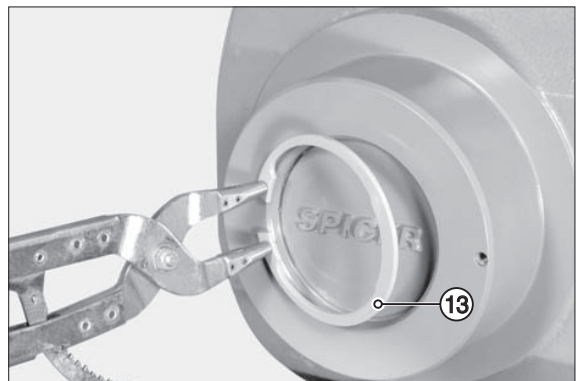

7409RAX085

(10) Remove the cap (29).

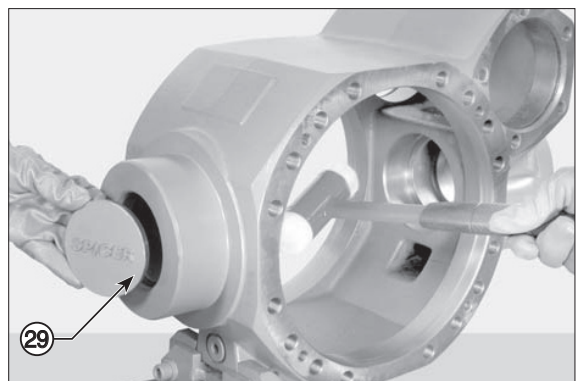

7409RAX086

(11) If the bearings need replacing, extract the external thrust blocks of the bearings (3) and (25) from middle cover (33)(38).

※ Accurately check the O-ring (37)(36).

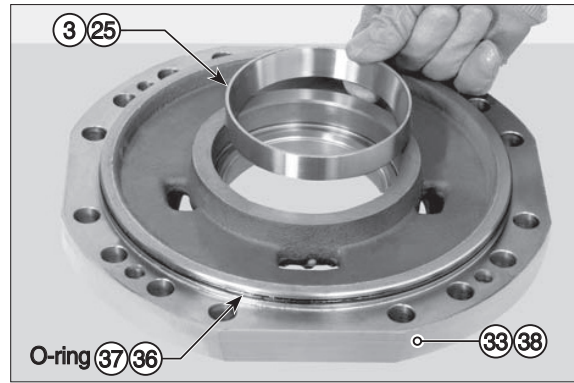

7409RAX087

(12) If the bearing need replacing, extract the bearing (3).



7409RAX088

(13) If the bearing need replacing, extract the bearing (25) from the differential carrier (23).

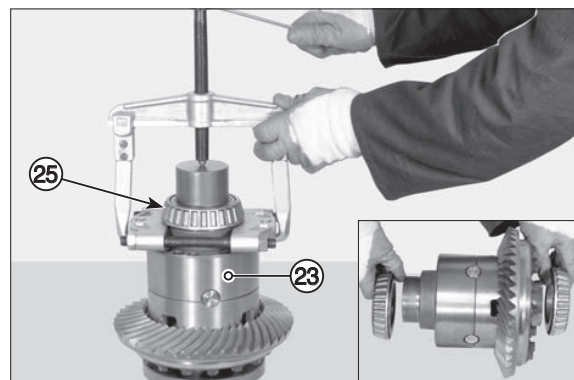

7409RAX089

(14) Remove the fitting screws (4) of the crown (6).



7409RAX090

(15) Remove the spacer (42) and the crown (6).

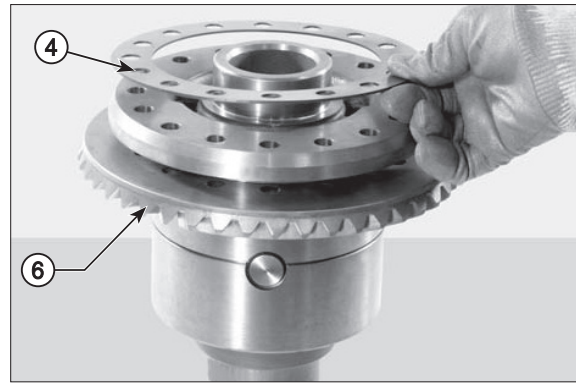

7409RAX091

(16) Remove the screws (24) jointing the differential unit half box .

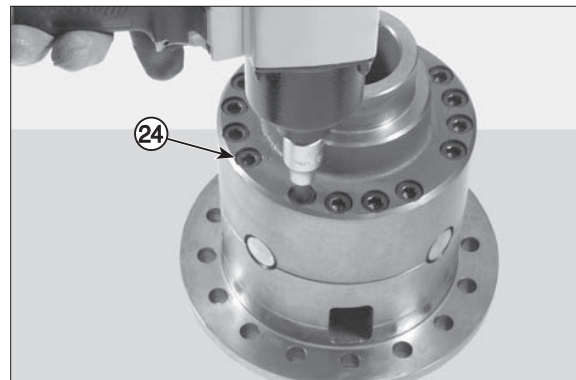

7409RAX092

(17) Using a plastic hammer, take the half box (23)(5) to pieces.

※ Note down the coupling marks.



7409RAX093

(18) Remove the upper half box (23).

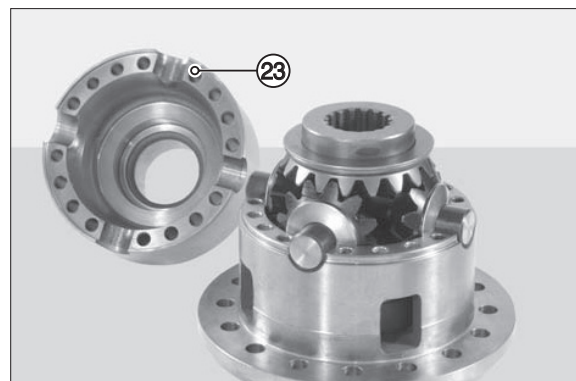

7409RAX094

(19) Remove shoulder (22) and first planetary gear (21).

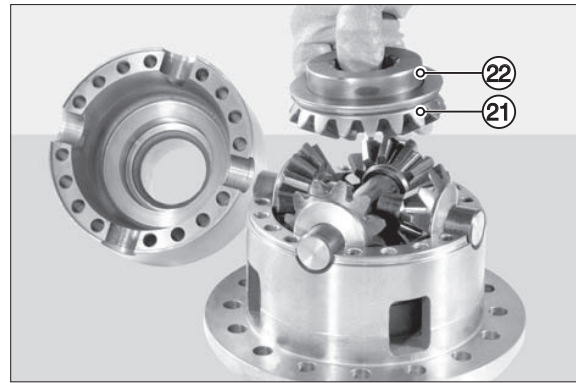

7409RAX095

(20) Remove shafts (18), complete with planet wheels (15)(19) and spherical shoulder washers (14)(20).

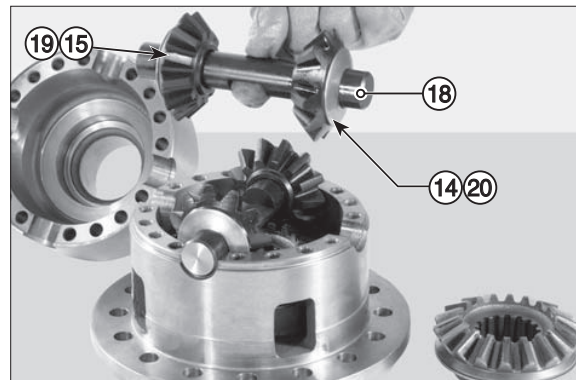

7409RAX096

(21) Remove shafts (17), complete with planet wheels (10)(12) and spherical shoulder washers (9)(13).

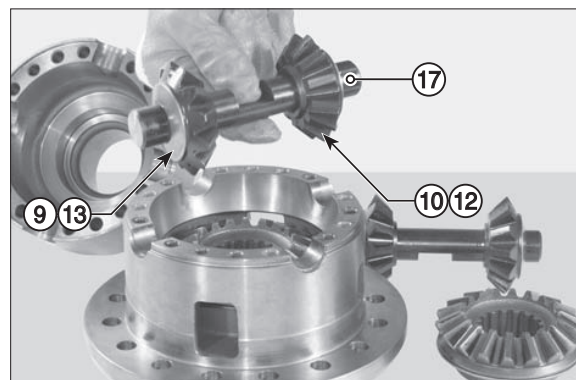

7409RAX097

(22) Remove the 2nd planetary gear (8) and shoulder ring (7).

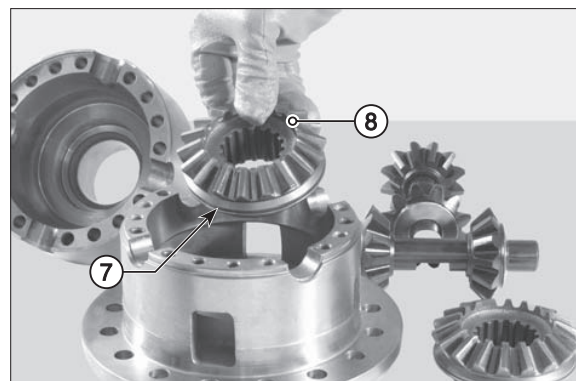

7409RAX098

(23) The differential unit.

Sh = shafts (18)(17)

SW = spherical shoulder washers (9)(13)
(14)(20)

P = planetary gears (8)(21)

SR = shoulder ring (22)(7)

23 = upper half box

5 = half box crown side

S = planet wheels (10)(12)(15)(19)

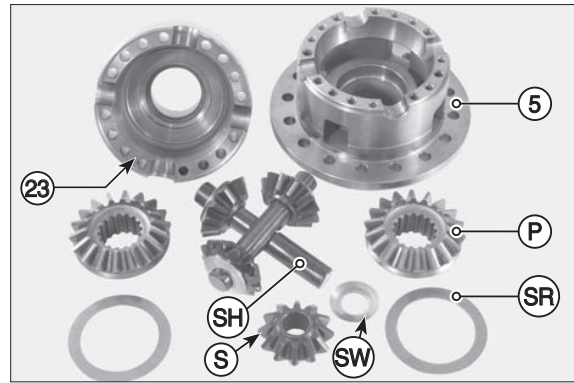

7409RAX099

6) HOW TO ASSEMBLE AND INSTALL THE DIFFERENTIAL UNIT

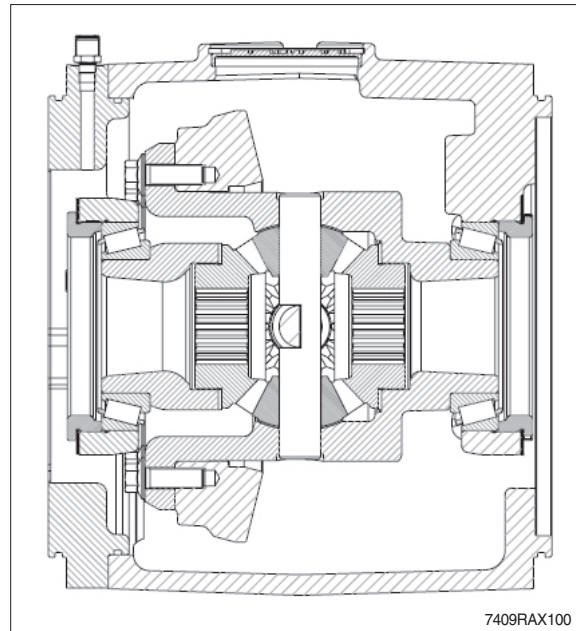

- (1) Install the shoulder ring (7) and planetary gear (8) into the halfbox (5).

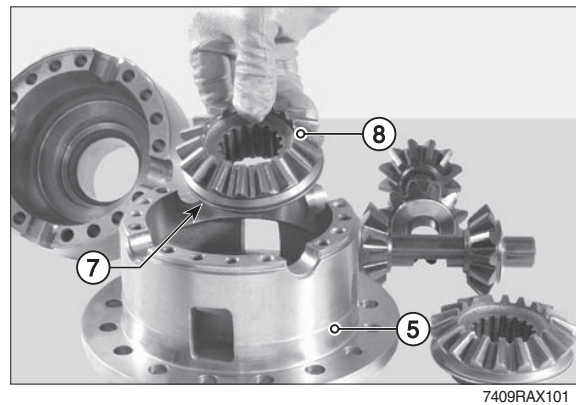

- (2) Install the planetary gears (10)(12) and spherical shoulder washers (9)(13) onto the shafts (17).
Install the planetary set.

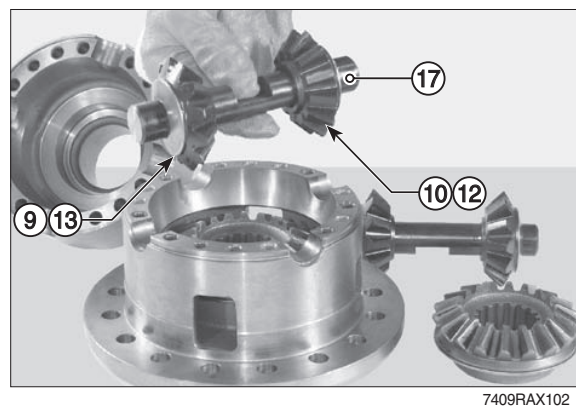

- (3) Install the planetary gears (15)(19) and spherical shoulder washers (14)(20) onto the shafts (18).
Install the planetary set.

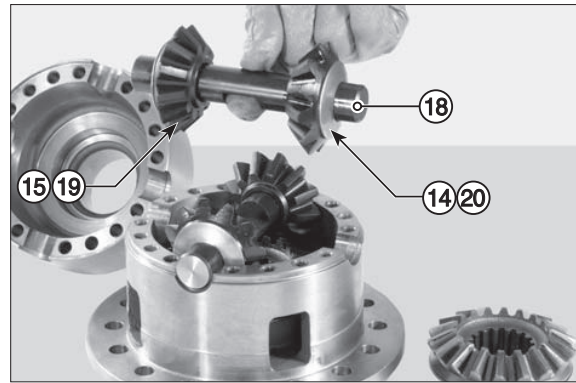

- (4) Install the planetary gear (21) and shoulder ring (22).

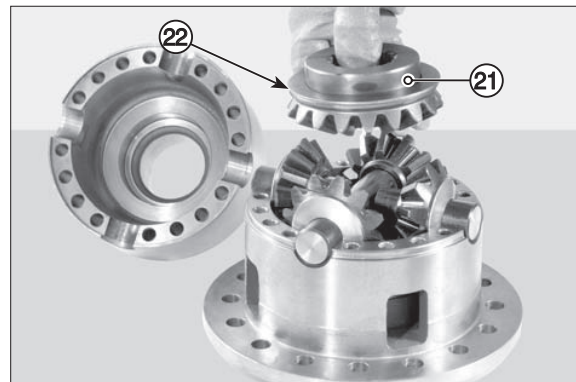

- (5) Mount the locking half-box (5) onto the half-box (23)

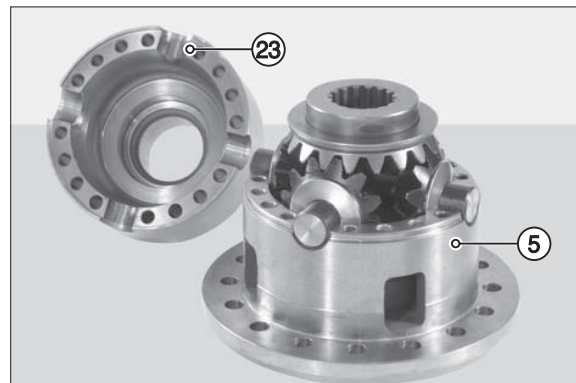

- (6) Lock the half box with screws (24) coated with loctite 270.

- ※ 1. The match marks on the two half-boxes must correspond.
- 2. Use only new screws.

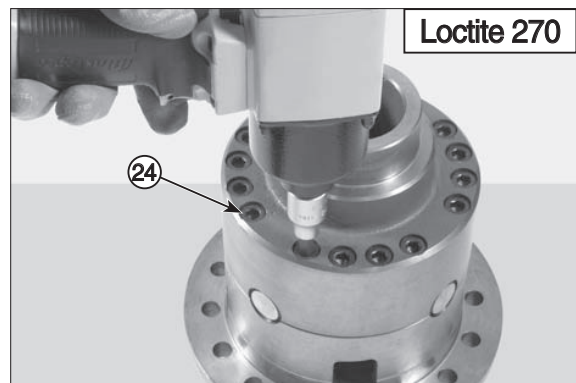

(7) Fit the complete differential unit in a vice and tighten the screws (24) holding the two half boxes together to a torque of 8.16 kgf · m (59 lbf · ft).

※ Tighten screws using the alternate and criss-cross method.

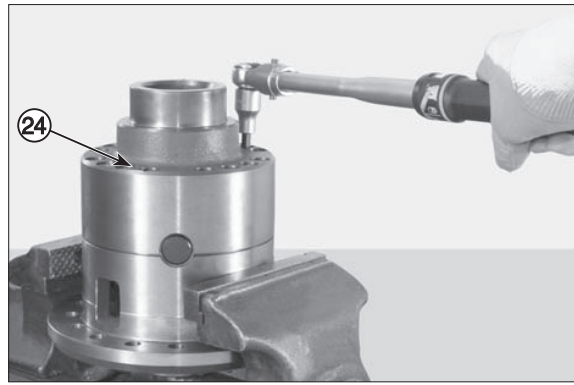

7409RAX107

(8) Install the spacer (4) and the crown (6).

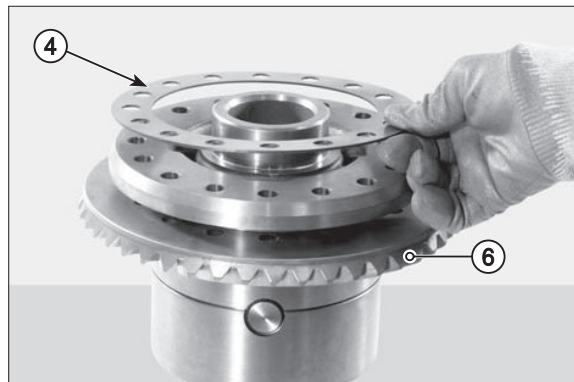

7409RAX108

(9) Mount the gear ring (6) and fasten it to the differential box with screws (4).

※ Use only new screws.

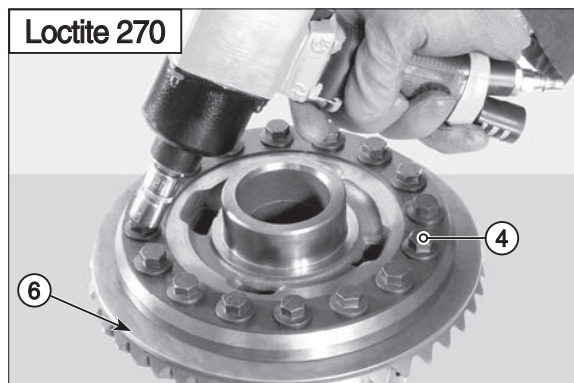

7409RAX109

(10) Lock the gear ring (6) by tightening the screws (4) to a torque of 15.3 kgf · m (111 lbf · ft).

※ Use the alternate and criss-cross tightening method.

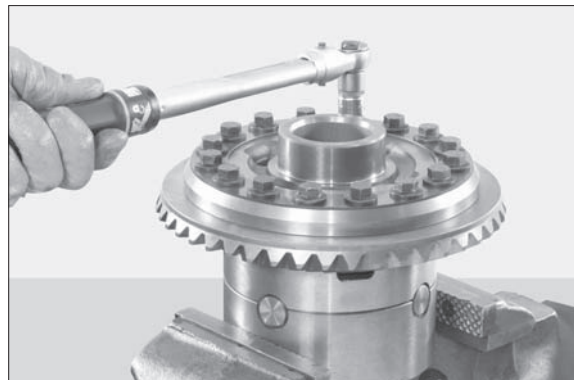

7409RAX110

Installation of the differential unit

- (11) Position the differential unit under a press and, using a driver with an adequate diameter, install the first bearing (3).

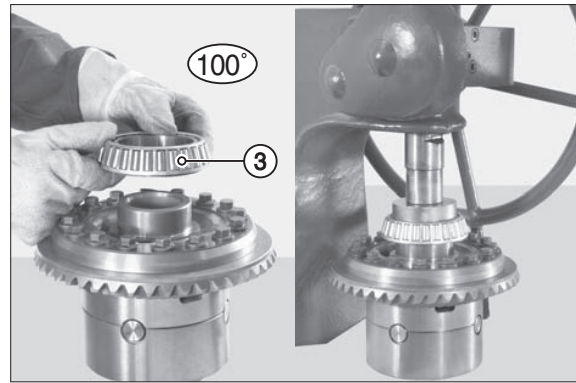

7409RAX111

- (12) Turn the unit upside down and install the second bearing (25).

- ※ Pay particular attention; position a shim with adequate diameter in order to engage the internal ring of bearing without engaging the cage.

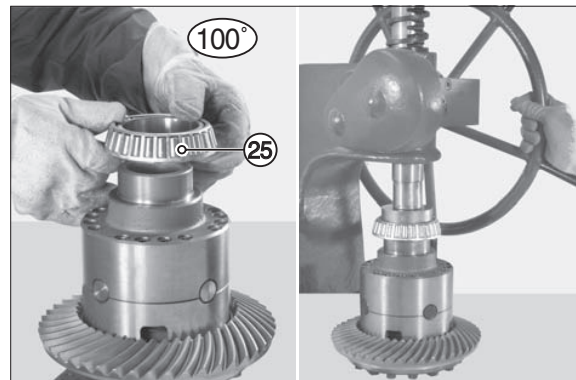

7409RAX112

- (13) Only if bearings are replaced.
Insert the thrust blocks of the bearings into the intermediate covers.

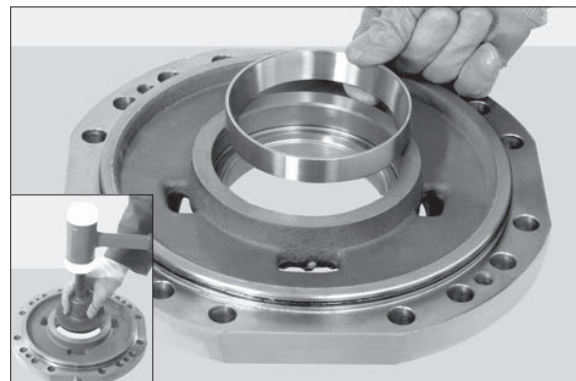

7409RAX113

- ※ Thoroughly check the state of the O-ring (36)(37).

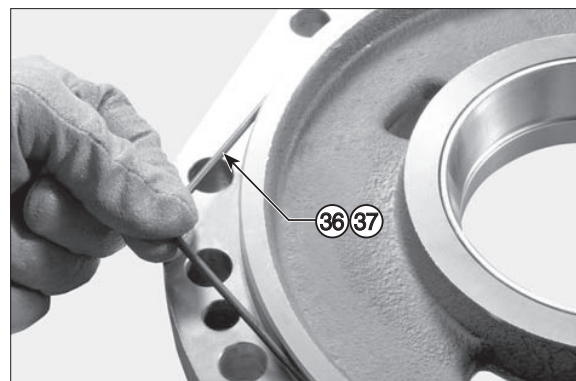

7409RAX114

- (14) Fit the intermediate cover (33) on opposite side of ring gears :
lock cover with screws (35) coated with loctite 242.
Tighten screws to a torque of 14.3 kgf · m
(103 lbf · ft).

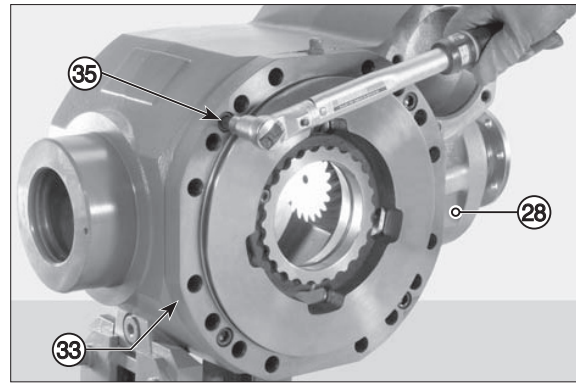

- (15) Position the differential unit in the central body with the help of a bar and fit the middle cover.

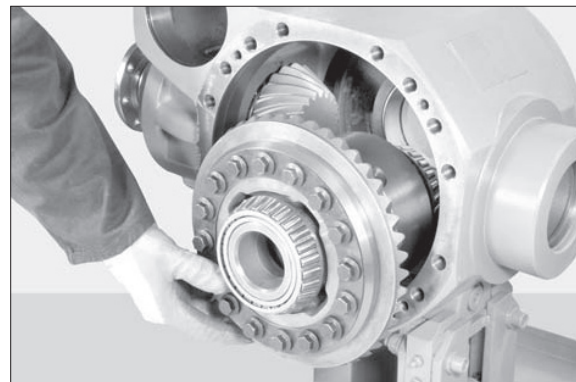

- (16) Tighten the two safety screws "C" into the main body (28) and install the intermediate cover (38).

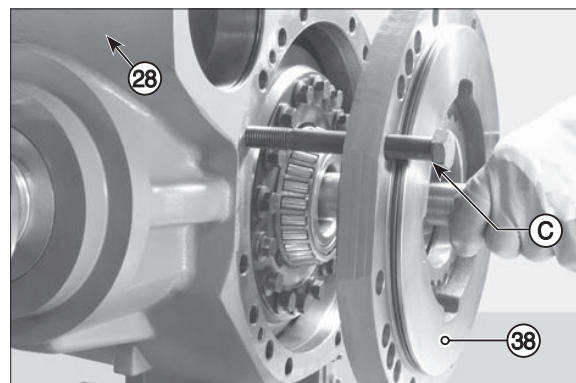

- (17) Tighten screws to a torque of 14.3 kgf · m
(103 lbf · ft).

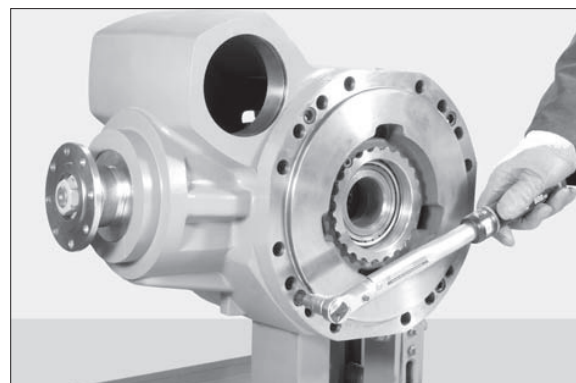

- (18) Only if ring nuts have been removed.
Tighten the ring nut (2) on gear ring side until clearances between pinion and gear ring are zeroed. Then, loosen by about 1/4 turn.

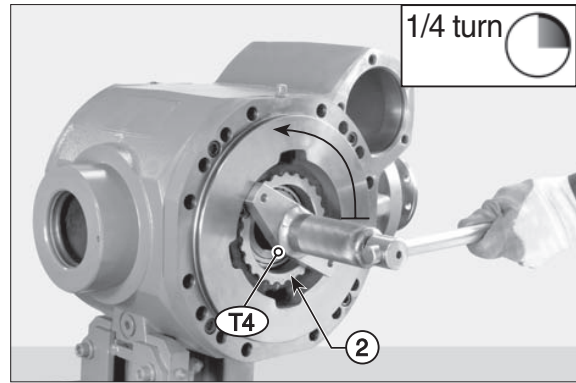

7409RAX119

- (19) Only if ring nuts have been removed.
Preload bearings with ring nut (26) on non-gear ring side in order to increase the torque of the pinion.

※ In the case of used bearings, check thrust torque ; in the case of new bearings, check continuous torque.

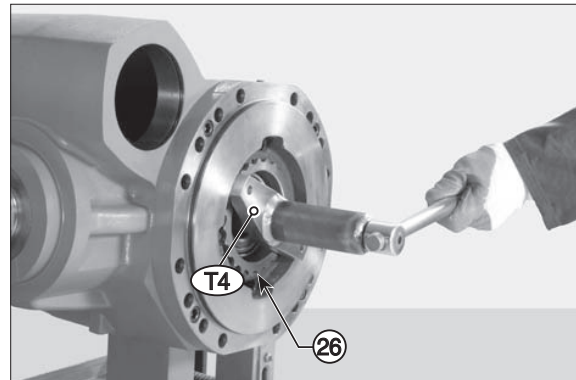

7409RAX120

- (20) Apply torque meter TM to pinion nut and check that torque will increase by 2.04~4.08 kgf · cm as a result of differential bearing preload.

- Example : pinion torque :
12.2~13.3 kgf · cm
- Pinion + differential torque :
14.3~17.3 kgf · cm

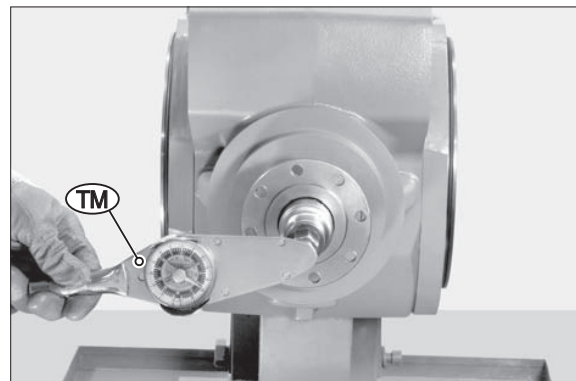

7409RAX121

- (21) Introduce a comparator "A" with long tracer through the hole provided for the cap.
Position the tracer on the side of a tooth of the gear ring, approximately 5 mm from the outer rim; preload by about 1 mm and zero the comparator.



7409RAX122

(22) As you hold the pinion in position, move the gear ring manually in both directions to check clearance between pinion and gear ring.

Standard clearance : 0.25 - 0.33 mm

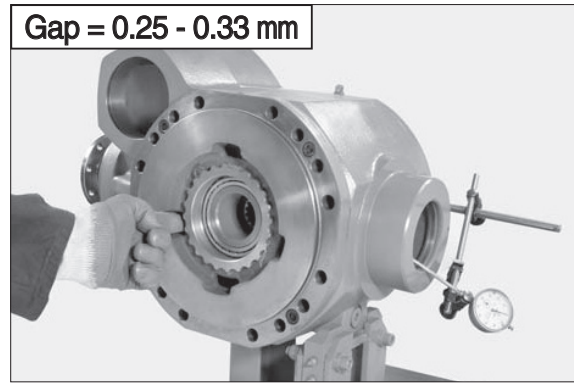

7409RAX123

(23) If torque and/or pinion-gear ring clearance is not within tolerance values and the ring nuts have not been removed, mark the position of the ring nuts (2)(26) and remove the safety stops (1)(27).

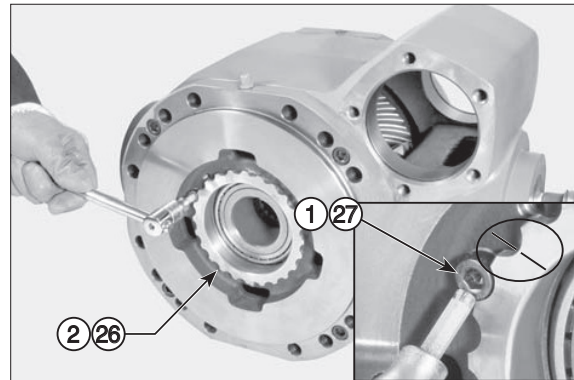

7409RAX124

(24) Adjusting clearance between pinion and gear ring.

To INCREASE: loosen the ring nut on gear ring side and tighten the ring nut on non-gear ring side by the same measure.

To DECREASE: perform the same operations inversely.

To rotate ring nuts, use special wrench T4.

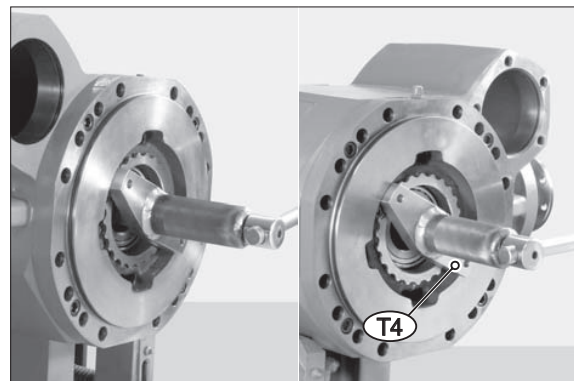

7409RAX125

(25) Engage screw (27) in the slot next to the holes provided for the check screws.

Coat screws (27) with loctite 242 and tighten to a torque of 2.45~2.65 kgf · m (17.7~19.2 lbf · ft).

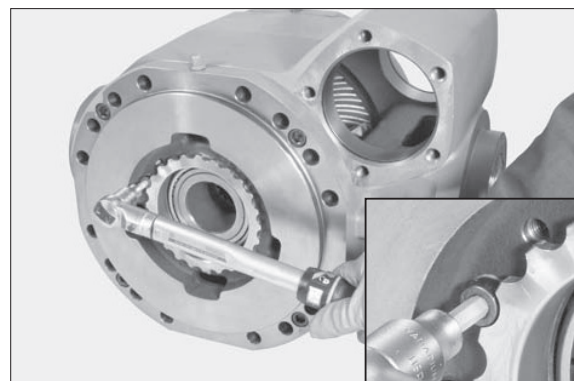

7409RAX126

- (26) Fit the top plug after applying repositionable jointing compound for seals to the rims.
Install the snap ring.



7409RAX127

- (27) Install the complete arm.

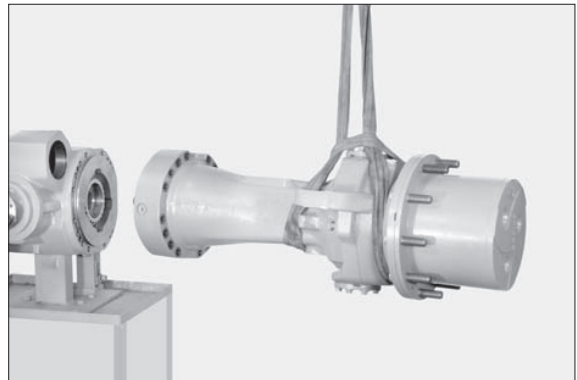

7409RAX128

- (28) Torque wrench setting :
28.9~31.8 kgf · m (209~230 lbf · ft)
※ Tighten using the criss-cross method.

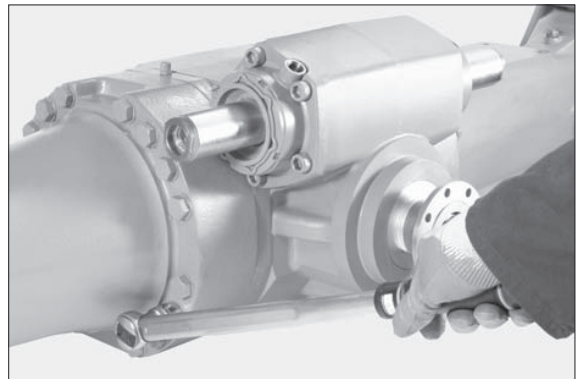

7409RAX129

7) DISASSEMBLY OF THE PINION

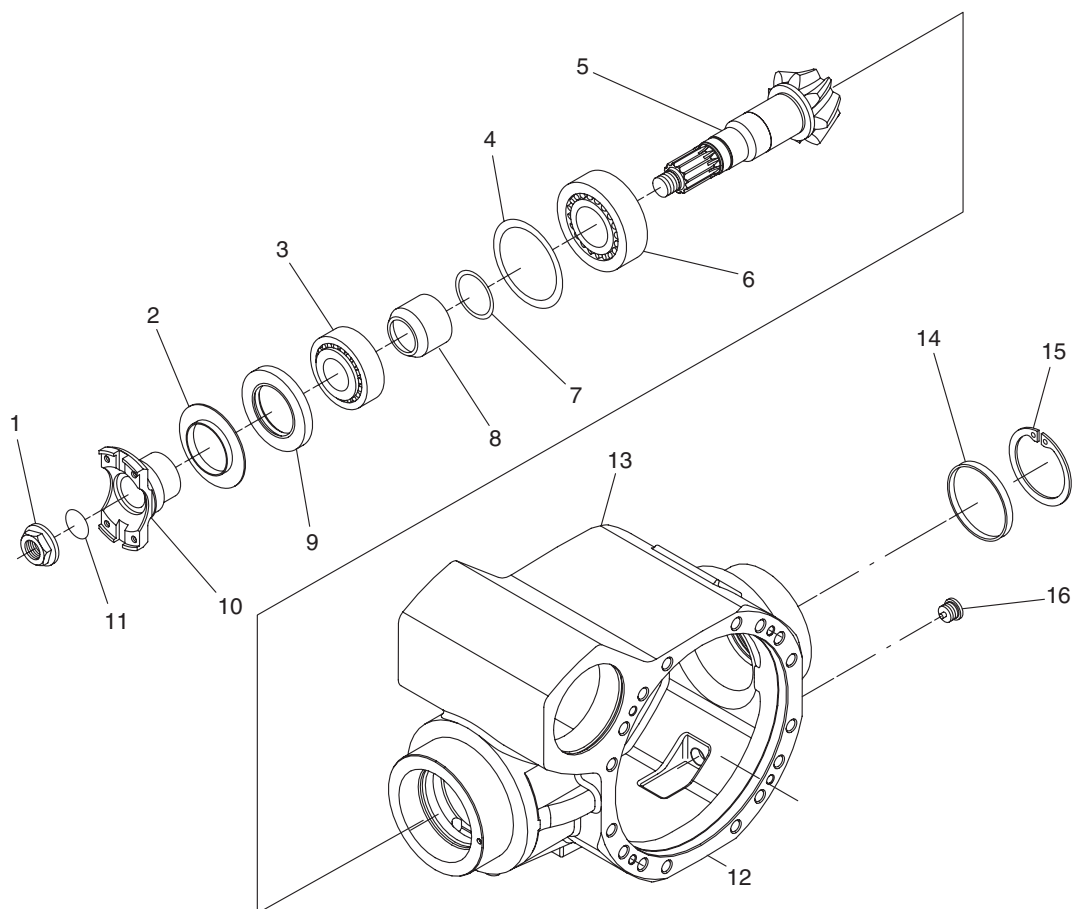

7409RAX130

(1) Remove both axle arms.

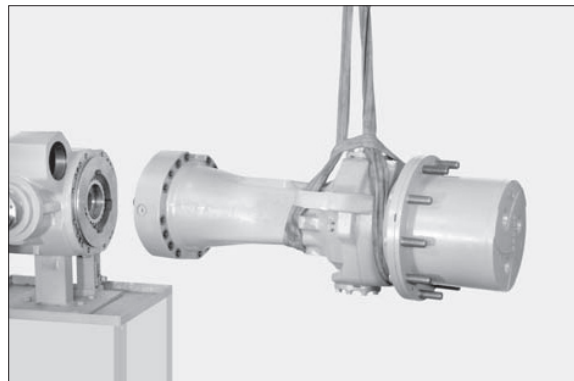

7409RAX131

(2) If disassembly is awkward, heat the check nut (1) of the flange (10) at 80°C.

※ Heating is meant to unloose the setting of loctite on the nut (1).

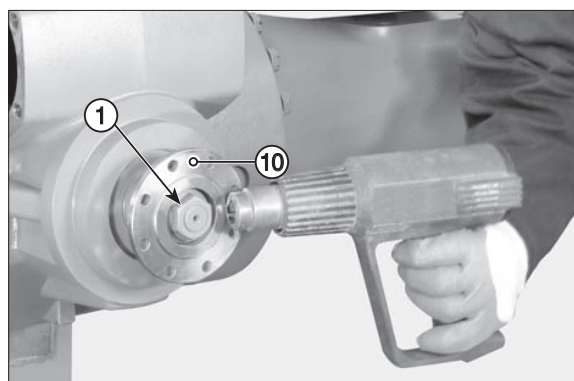

7409RAX132

- (3) Position tool T12, so as to avoid pinion rotation.
Unloose and remove the nut (1); also remove the O-ring (11).

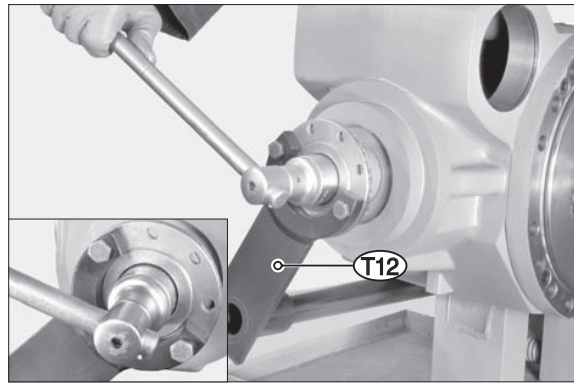

7409RAX133

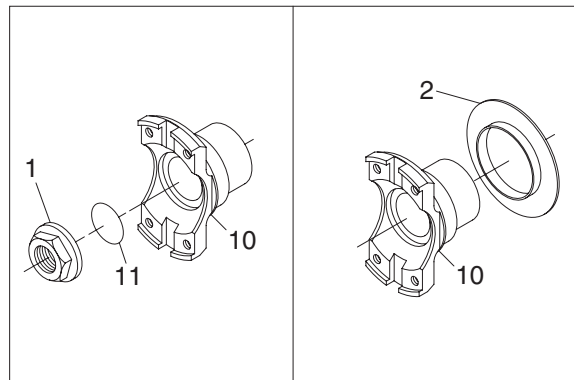

7409RAX134

- (4) Remove the flange (10) complete with guard (2).

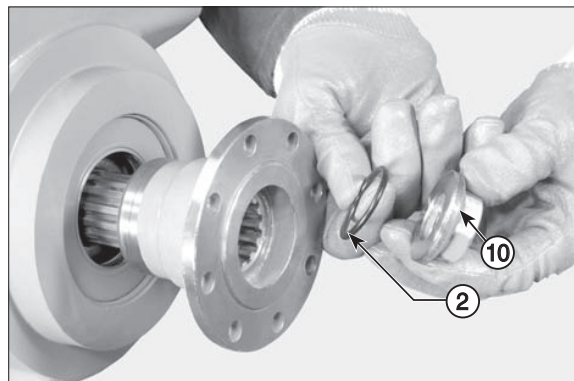

7409RAX135

- (5) Remove the sealing ring (9).

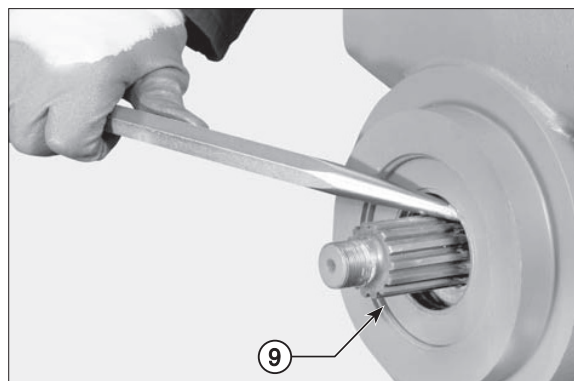

7409RAX136

(6) Apply blocks T15 and, with the help of a puller, extract the pinion (5) complete with the internal bearing (6), the distance piece (8) and shims (4)(7).

※ The thrust blocks of the bearings remain in the central body (12).

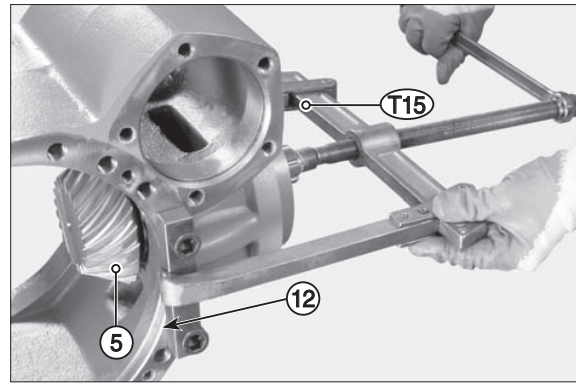

7409RAX137

(7) Refer and keep to the positions marked during disassembly.

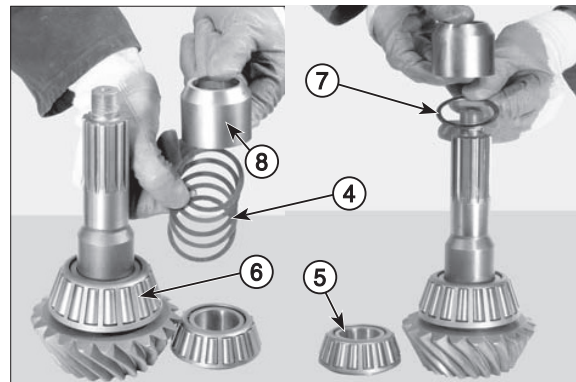

7409RAX138

(8) Using a puller and a press, remove the inner bearing (5) from the pinion (6).

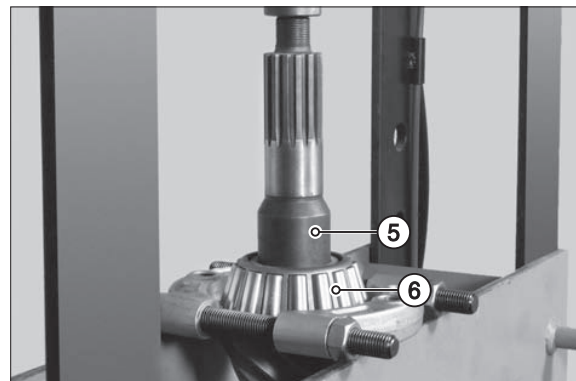

7409RAX139

(9) Remove the thrust block of the external bearing (3).

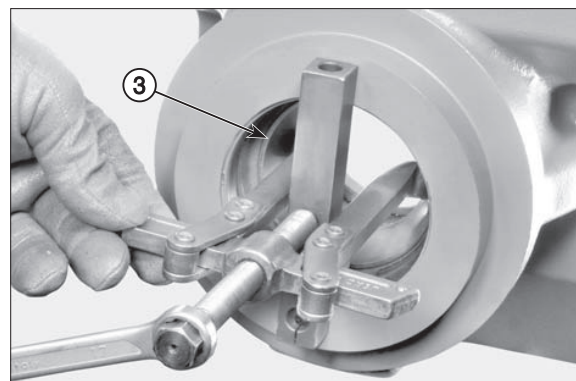

7409RAX140

(10) Insert a drift in the appropriate holes.

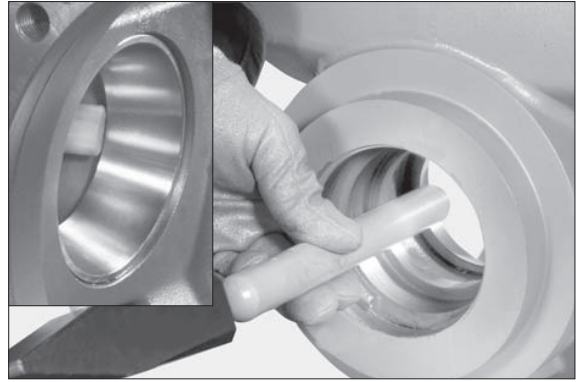

7409RAX141

(11) Remove the thrust block of the internal bearing (6) as well as the shim washers (4).

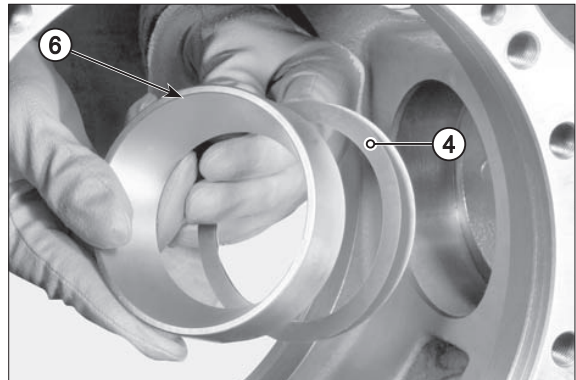

7409RAX142

(12) Remove the snap ring (15).

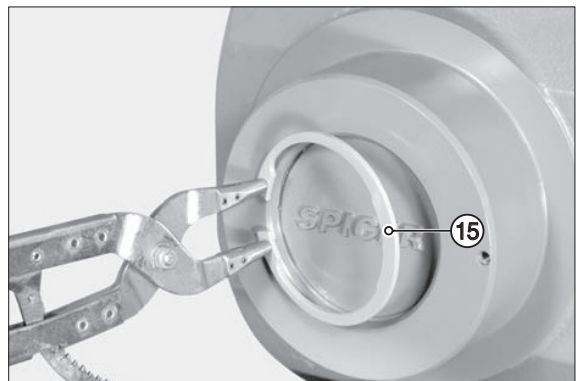

7409RAX143

(13) Remove the cap (14).

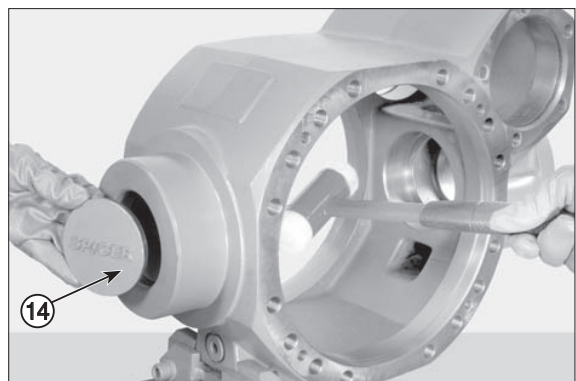

7409RAX144

8) ASSEMBLY OF THE PINION

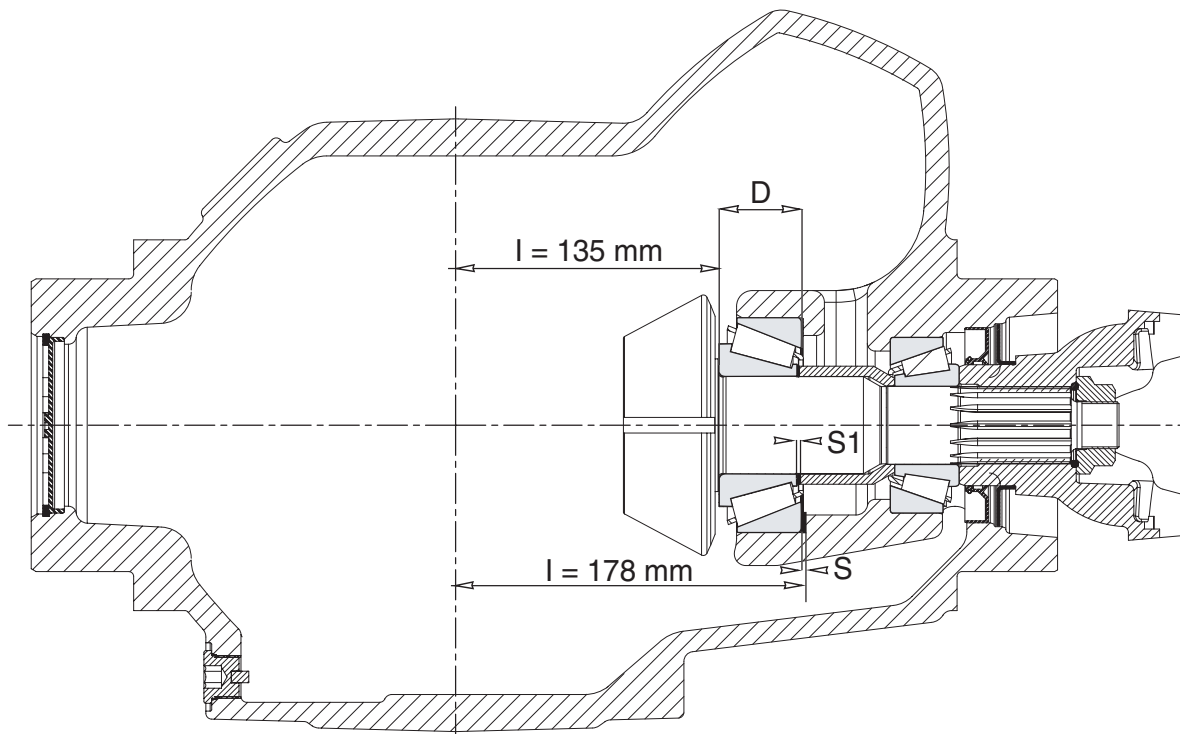

$$S = 178 - (I + D) \quad S = \text{shims } \varnothing 110 \text{ mm}$$

$$S1 = \text{shims } \varnothing 50 \text{ mm}$$

7409RAX145

Calculating pinion center distance

- (1) Using a faceplate, reset a centesimal comparator "DG" on a calibrated block (whose known thickness is 42 mm). Preload the comparator by about 3 mm.

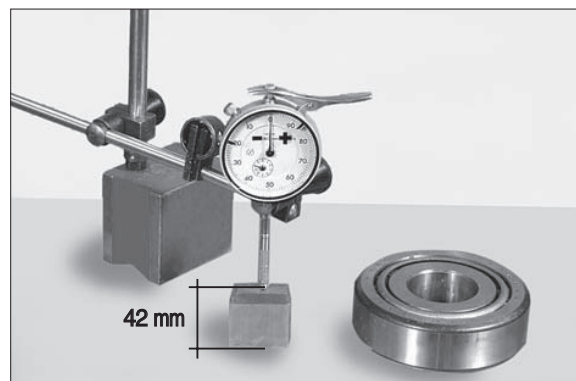

7409RAX146

- (2) Bring inner bearing (6), complete with thrust block, under comparator "DG".

※ Press the thrust block centrally and carry out several measurements by rotating the thrust block.

Example : $42 + 0.5 = 42.5 = "D"$.

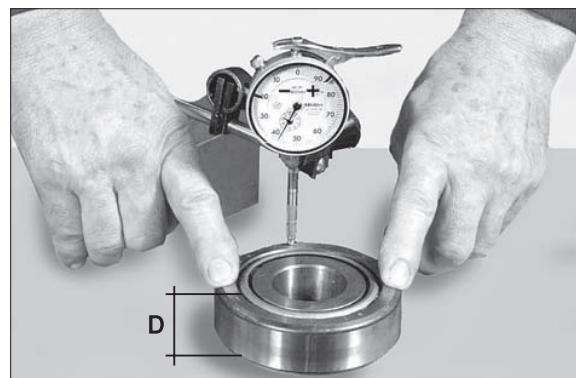

7409RAX147

- (3) Check nominal dimension “I” as marked on the pinion. Add up to or subtract from “I” the variation indicated as “Y” to obtain the actual center distance “I”.

Example : $I = 135 - 0.1 = 134.9$

※ M5 = Match part number

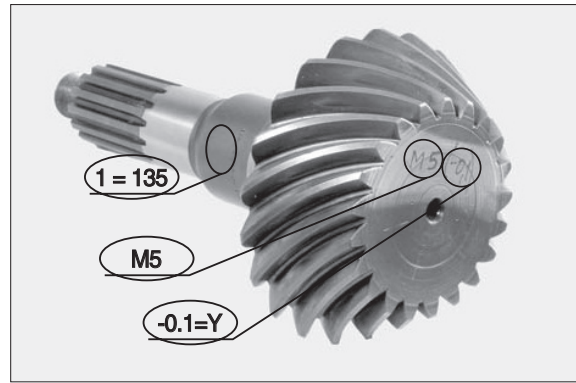

7409RAX148

- (4) Calculate shims “S” for insertion under the thrust block of the inner bearing using the following formula :

$S = 178 - (I + D)$ where : 178 = fixed dimension

I = actual pinion center distance

D = total bearing thickness ;

Example :

$S = 178 - (134.9 + 42.5) = 0.6 \text{ mm.}$

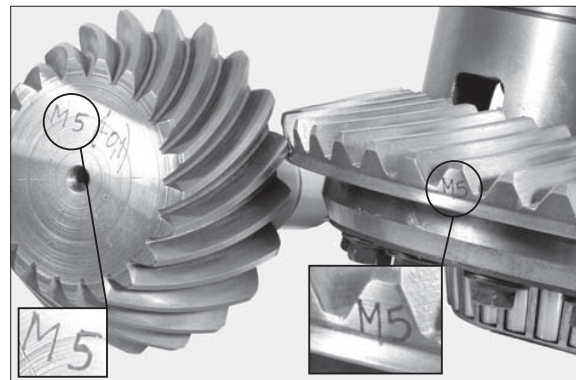

7409RAX149

- (5) Using special tool T10.
Partially insert the thrust block of the bearings (3) (6) and shims (4) .

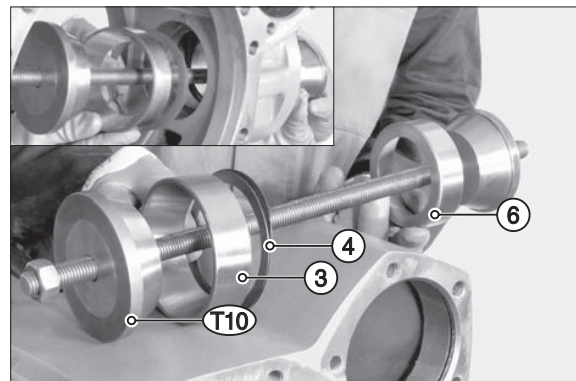

7409RAX150

- (6) Connect the tension rod to the press and move the thrust block of bearings (3) (6) into the seats.
Disconnect the press and remove the tension rod.

※ Before starting the next stage, make sure that the thrust block has been completely inserted into its seat.

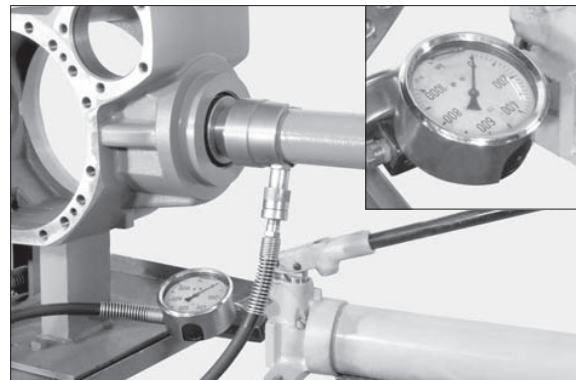

7409RAX151

Calculating pinion bearings rolling torque

- (7) Introduce tool T11 complete with bearings (3) and (6) into the main body (12); tighten by hand until a rolling torque is definitely obtained.

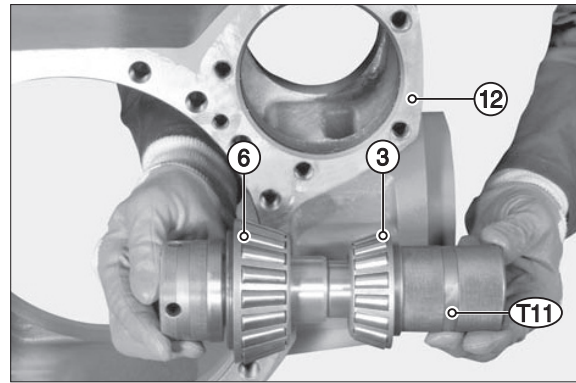

7409RAX152

- (8) Introduce the tracer of a depth comparator “DDG” into either side hole of tool T11. Reset the comparator with a preload of about 3 mm.

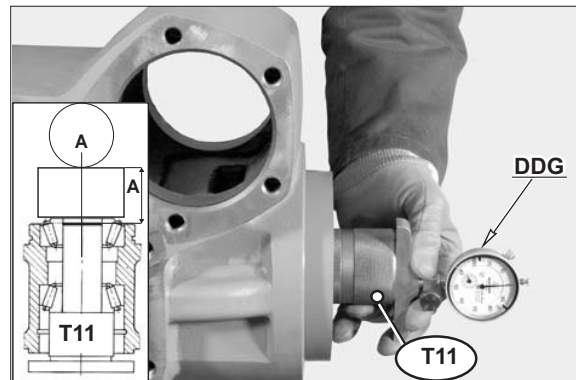

7409RAX153

- (9) Remove the comparator and take out tool and bearing kits from the main body. Reinstall every part, also introducing a distance piece between bearings (3) and (6). Tighten the entire pack by hand.

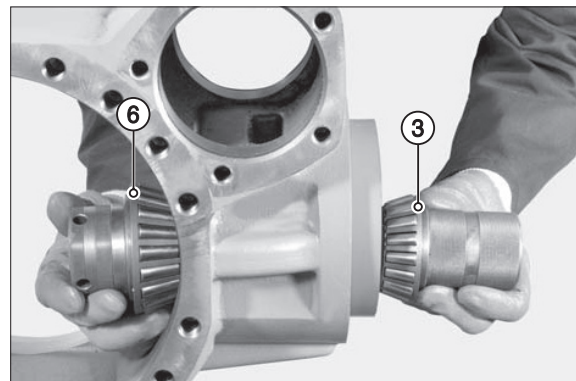

7409RAX154

- (10) Introduce depth comparator “DDG” in tool T11 and measure deviation “H” from the previous reset.

Example : $H = A - B = 1.19 \text{ mm}$.

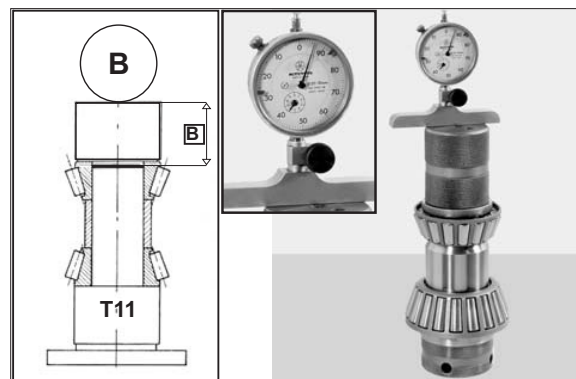

7409RAX155

(11) Deviation “H” must be added to a set value of 0.12~0.13 mm (X) to make up the pack of shims “S1” (4) for insertion between inner bearing (6) and distance piece (8).

Dimension “S1” must be rounded off to the higher 5/100.

$$\text{Example : } S1 = H + X = 1.19 + (0.12 \sim 0.13) \\ = 1.33 \sim 1.35 \text{ mm.}$$

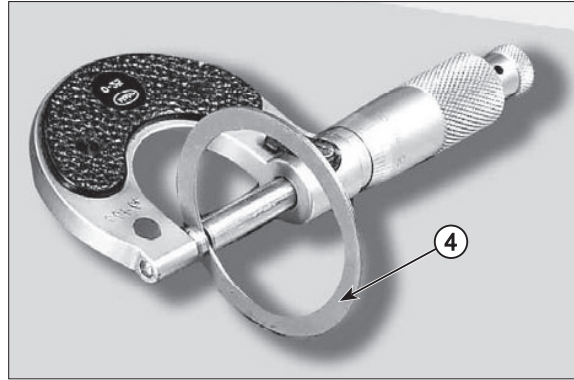

7409RAX156

(12) Heat the inner bearing (6) to about 100°C and fit it to the pinion (5).

※ Once the bearing has cooled down, lightly lubricate bearing (6) with SAE 85W90 oil.



7409RAX157

(13) Make sure that the bearing (6) is well set.

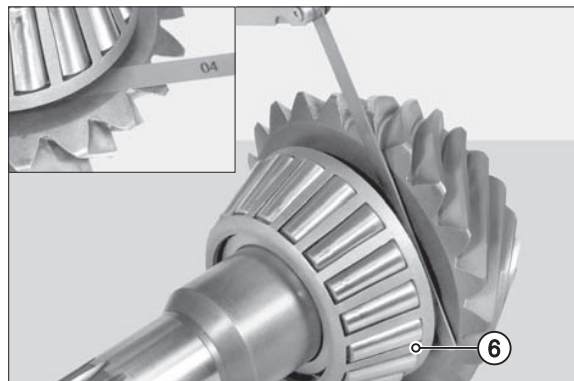

7409RAX158

(14) Refer and keep to the positions marked during disassembly.

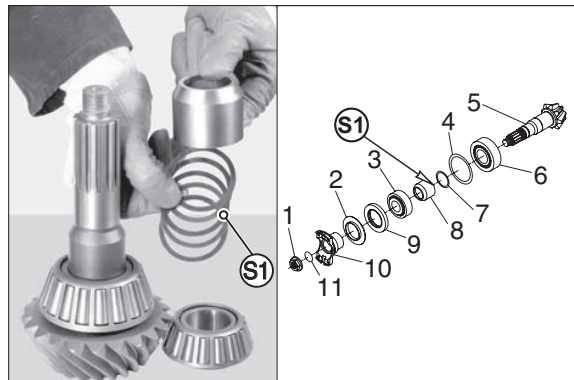

7409RAX159

(15) Fit the pinion (5), shim "S1" (7) and distance piece (8) in the main body (12).

※ The finer shims must be placed in-between the thicker ones.

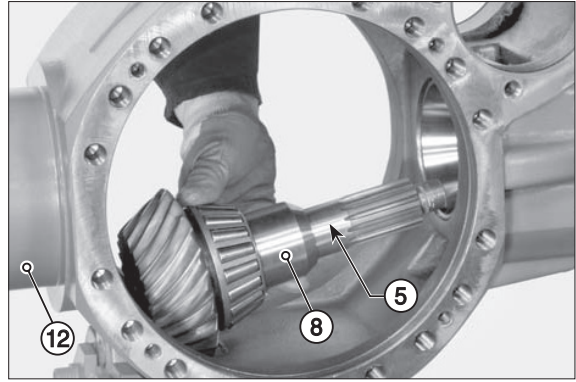

(16) Heat the external bearing (3) to a temperature of about 100°C and fit it on to the pinion (5) so as to complete the pack as shown in the figure.

※ Lightly lubricate bearing (3) with SAE 85W90 oil.

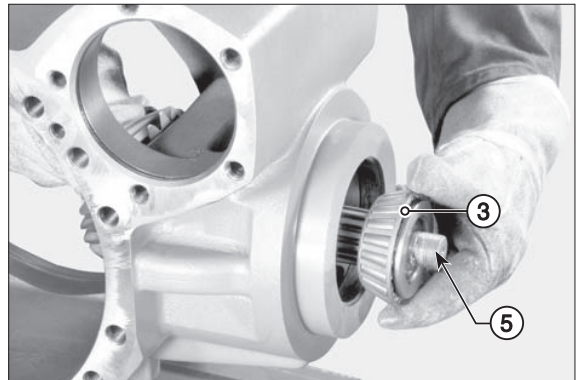

(17) Install the flange (10) onto the pinion (5) without sealing ring.

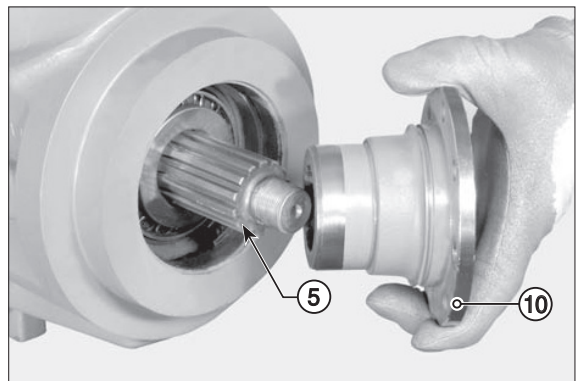

(18) Apply wrench to the ring nut (1) and bar-hold T12 to the pinion (5).

Lock the wrench T12 and rotate the pinion using a dynamometric wrench, up to a minimum required torque setting of 81.6~102 kgf · m (590~738 lbf · ft)

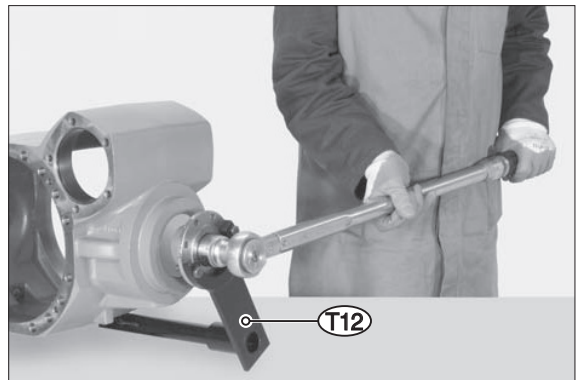

(19) Apply onto the pinion (5) the bar-hold and with the help of a torque meter, check the torque of the pinion (5).

· Torque : 12.2~18.4 kgf · cm

※ If torque exceeds the maximum value, then the size of shim “S1” (7) between the bearing (6) and the distance piece (8) needs to be increased.

If torque does not reach the set value, increase the torque setting of the ring nut (1) in different stages to obtain a maximum value of 81.6~102 kgf · m (590~738 lbf · ft).

※ If torque does not reach the minimum value, then the size of shim “S1” (7) needs to be reduced.

※ When calculating the increase or decrease in size of shim “S1”, bear in mind that a variation of shim (4) of 0.01 mm corresponds to a variation of 6.12 kgf · cm in the torque of the pinion (5).

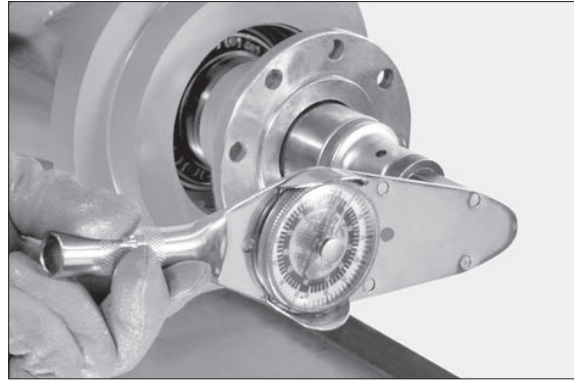

7409RAX164

(20) Make positional marks across nut (1) and pinion (5) tang ; then remove nut and flange (10)

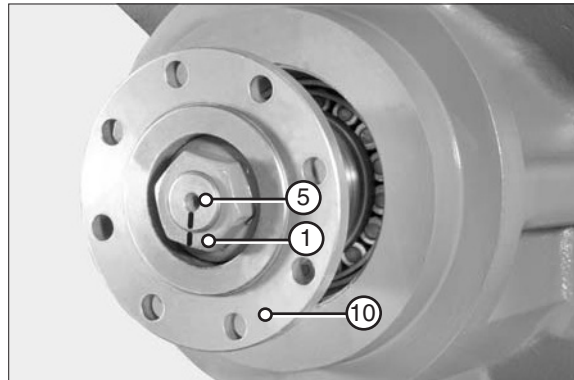

7409RAX165

(21) Apply Arexons rubber cement to the outer surface of the new seal ring (9) and fit ring in the main body (12) using driver T13.

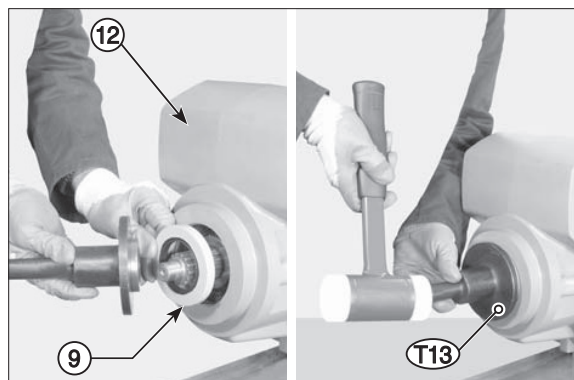

7409RAX166

(22) Fit the safety flange (2).

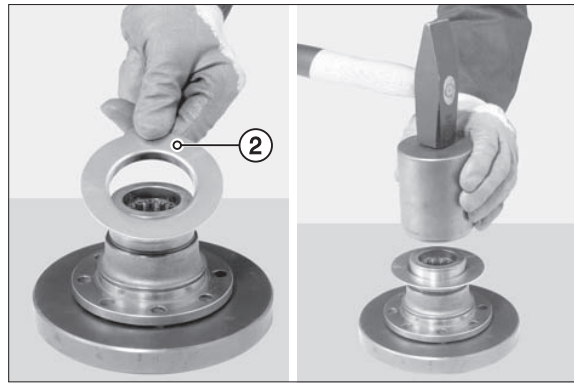

(23) Oil seal ring lips and install flange (10).
Mount O-ring (11) and apply loctite 242 to pinion tang; tighten nut (1).

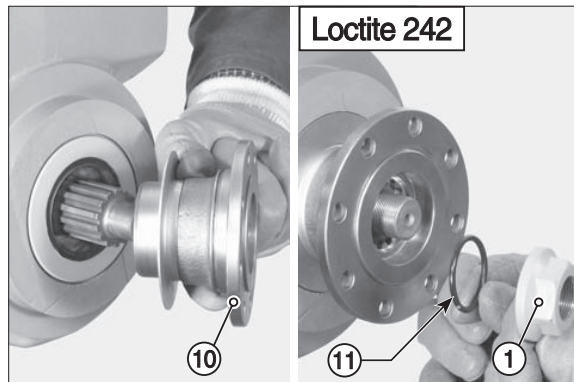

(24) Tighten the nut until the match marks made at stage "a" line up.

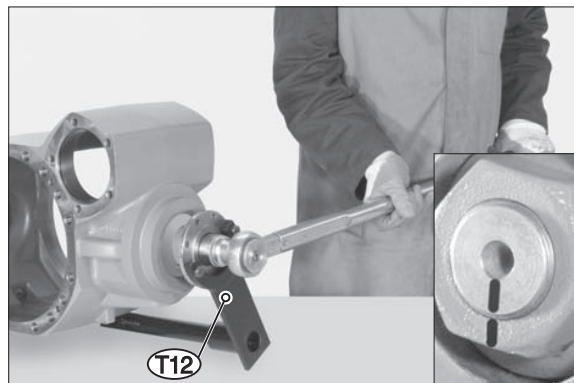

9) DISASSEMBLE THE SWINGING SUPPORT

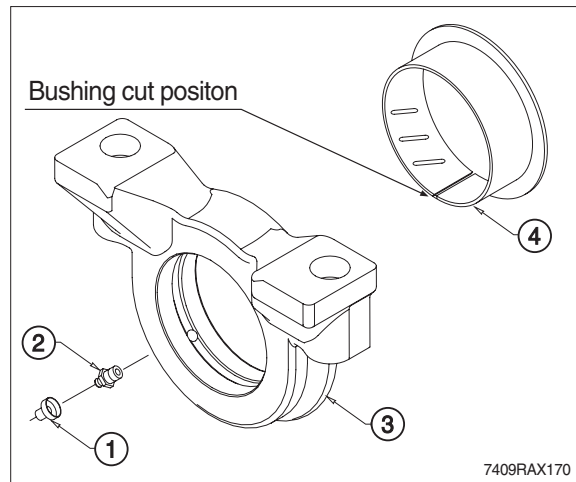

(1) Remove the swinging support (3).



(2) Remove the swinging support (3) on the side opposite the drive.

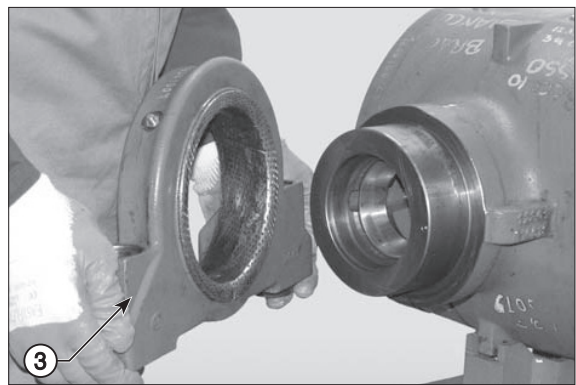

(3) Position the swinging support (3) under a press and remove the complete bushing (4).

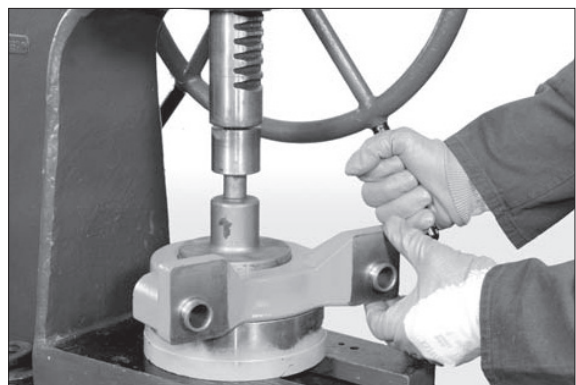

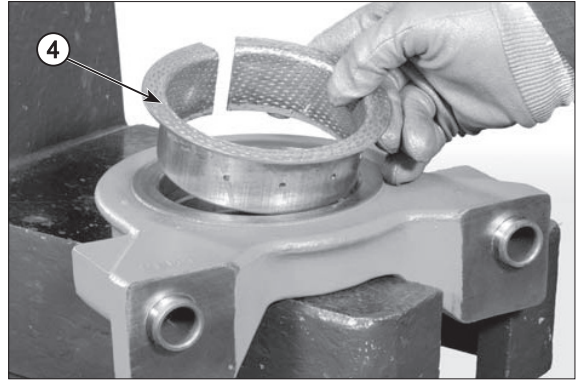

7409RAX174

(4) Remove the screws.

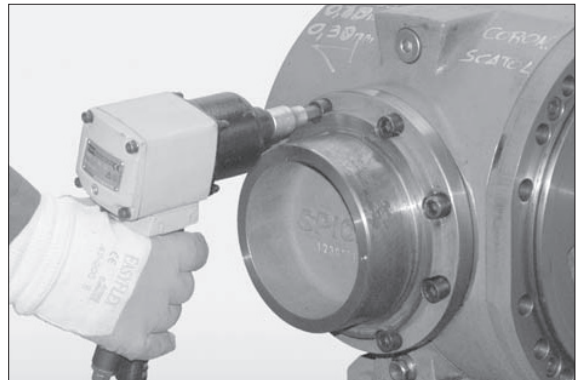

7409RAX175

(5) Disjoin the cover from the differential box by alternatively forcing a screwdriver into the appropriate slots.

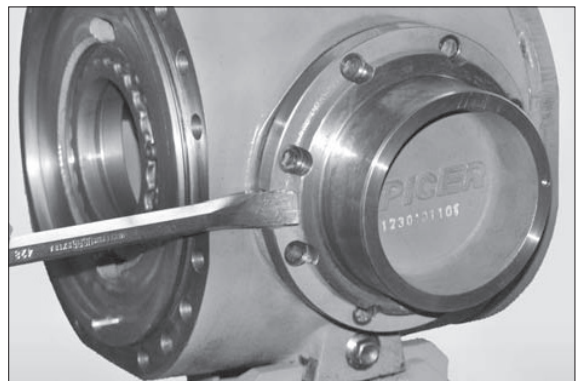

7409RAX176

(6) Check integrity and position of the cylinder's O-ring.

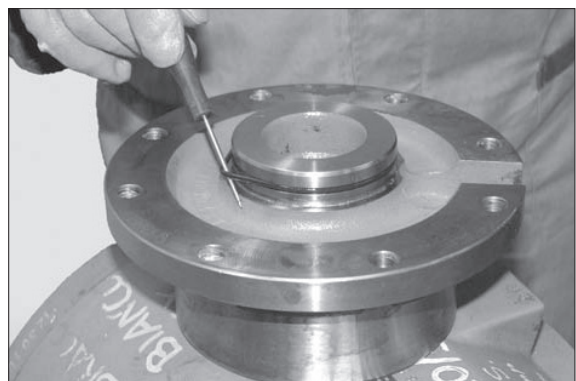

7409RAX177

10) ASSEMBLY THE SWINGING SUPPORT

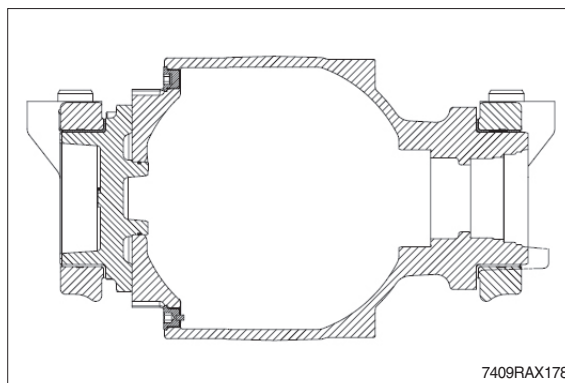

(1) Install the cover.

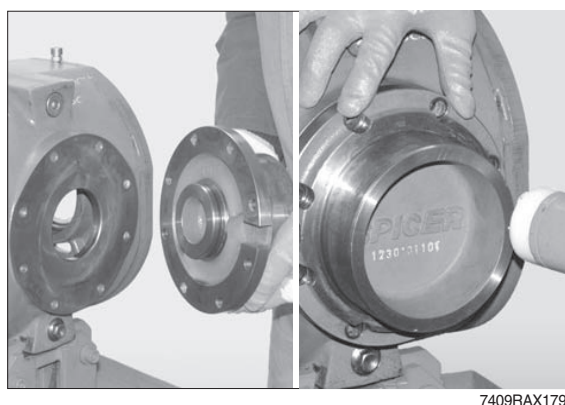

(2) Lock the cover by tightening the screws.

Torque wrench setting for screws :

4.08~5.1 kgf · m (29.5~36.9 lbf · ft)

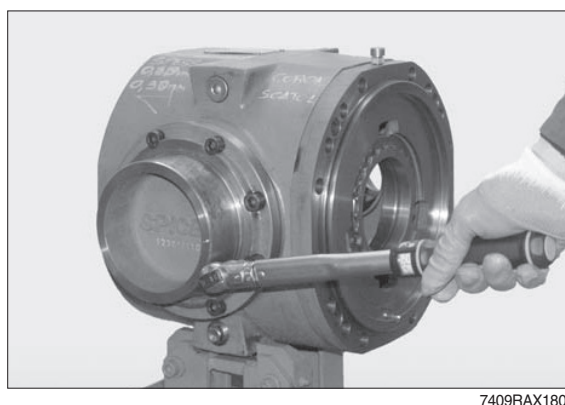

※ If the bushing (4) is worn and needs replacing, note down the assembly side of the connection notch "A".

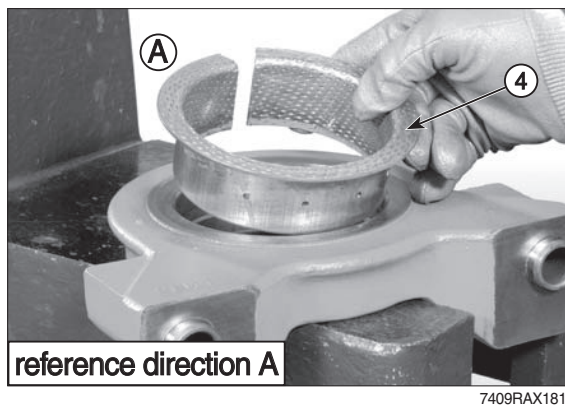

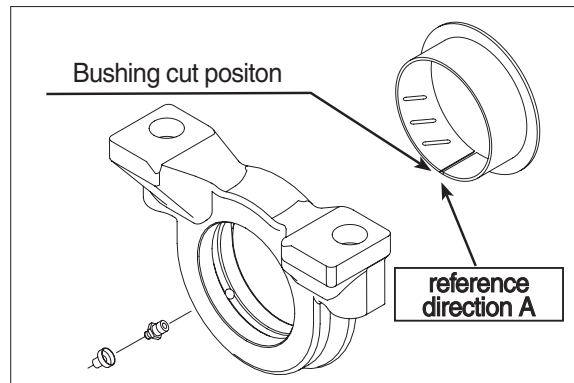

7409RAX182

- (3) Position the swinging support (3) under a press and insert the complete bushing (4).

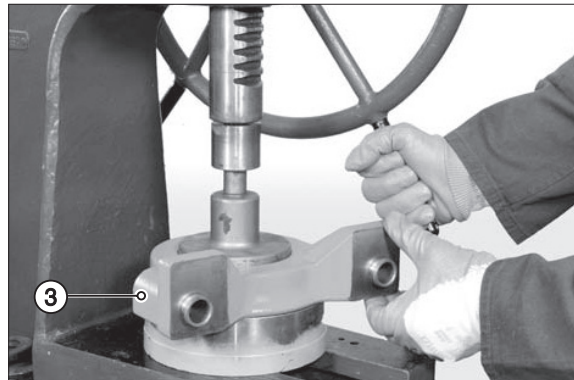

7409RAX183

- (4) Install the swinging support (3).
 ※ Check that it is properly oriented.

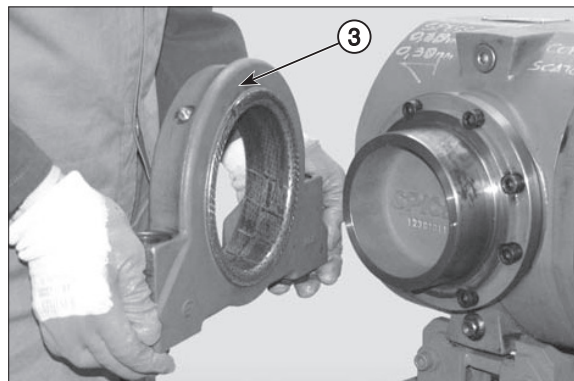

7409RAX184

- (5) Install the swinging support (4) on the side opposite the drive.

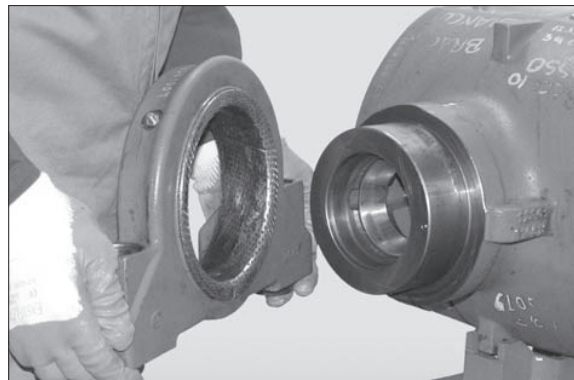

7409RAX185

11) NEGATIVE BRAKE : ASSEMBLING NEGATIVE BRAKE DISKS

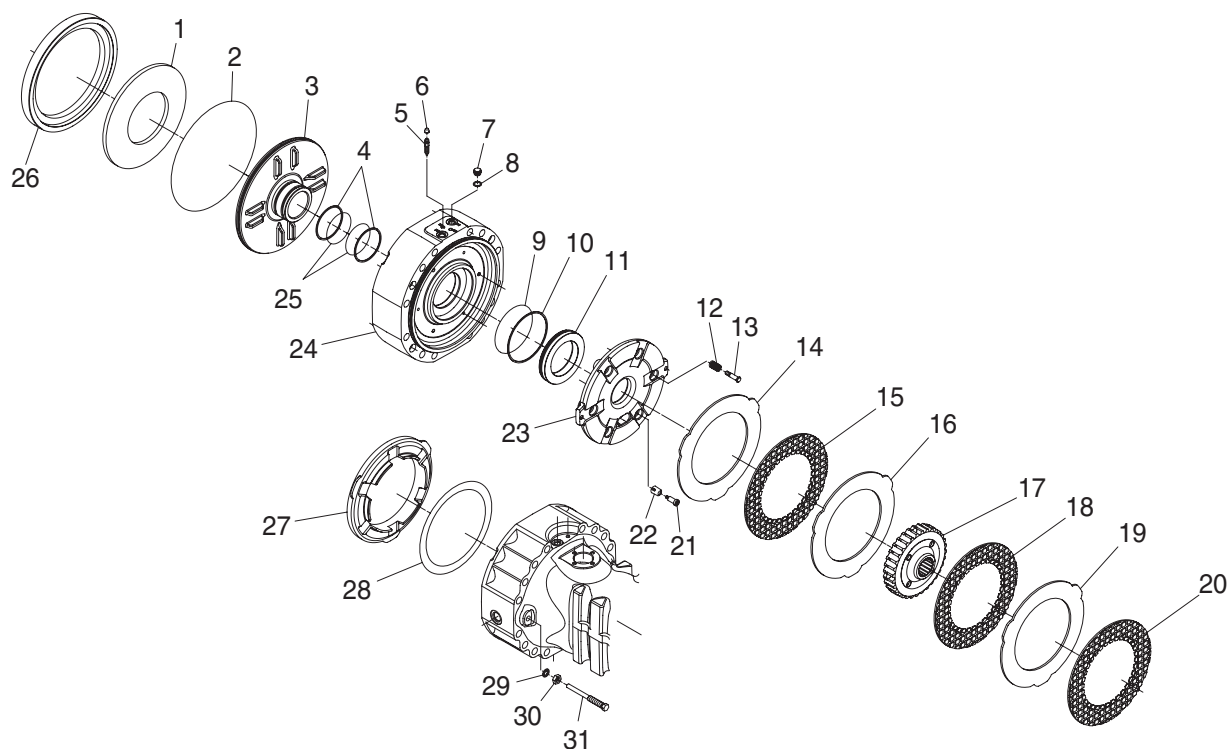

7409RAX186

Manual emergency release

- (1) Loosen nuts (30) of screws (31) provided for the mechanical and manual release of the braking units, then move the nuts backwards by approx. 8 mm.

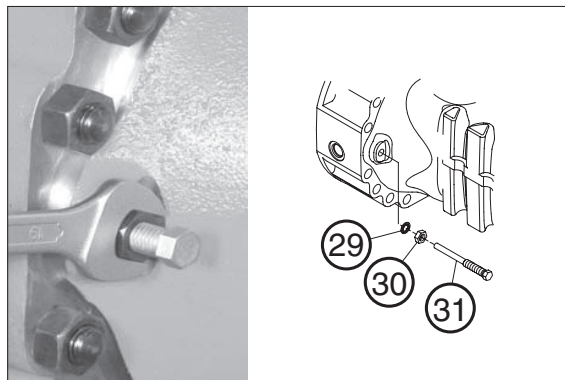

7409RAX187

- (2) Tighten screws (31) so as to fasten them onto the pressure plate (23).

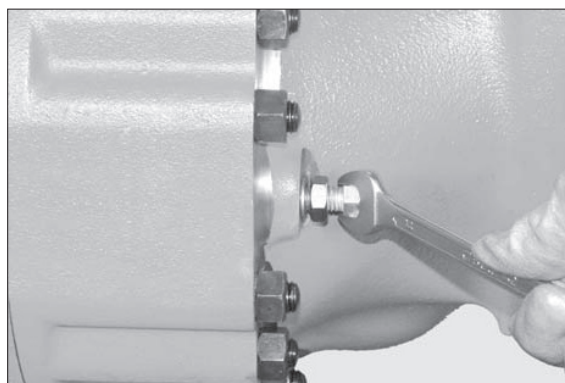

7409RAX188

- (3) Using a wrench, tighten the screws (31) in an alternate sequence by 1/4 turn at a time so as to compress the belleville washers (1) and disengage the braking disks.

※ Tighten max. by one turn.

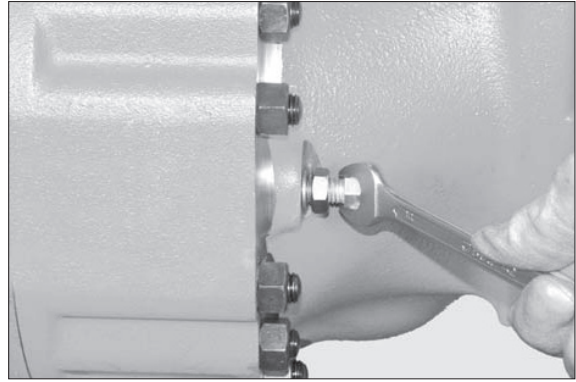

7409RAX189

Adjustment after manual release

- (4) Remove screws complete with nuts and seals.

Replace seals, apply grease to the screws and install all parts into the arm.

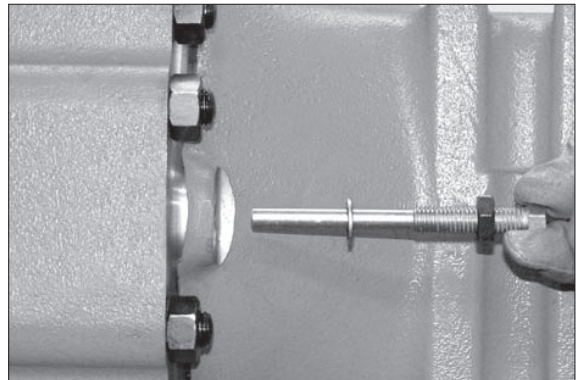

7409RAX190

- (5) Adjust screws (31) to obtain a jut of 30 ± 0.5 mm in relation to the arm.

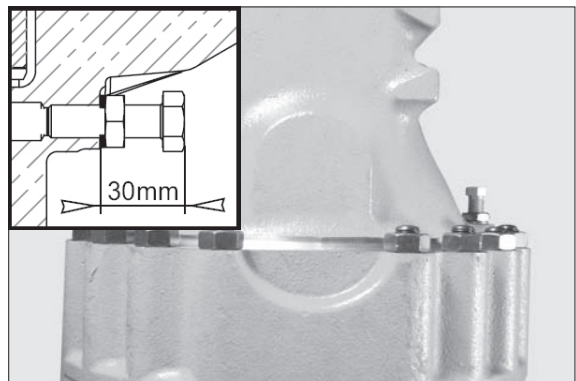

7409RAX191

- (6) Lock into position with nuts (30).

※ Hold screws (31) into position while locking the nuts (30); after locking, check the jut of screws (31) once more.

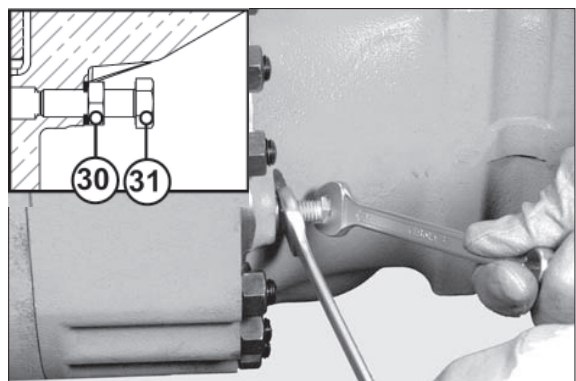

7409RAX192

11) NEGATIVE BRAKE : DISASSEMBLING

- (1) Connect an external pump to the union piece "P1" of the negative brake and introduce a pressure of 21.4~35.7 kgf/cm² (304~508 psi) to eliminate the pressure of the belleville washers (1).

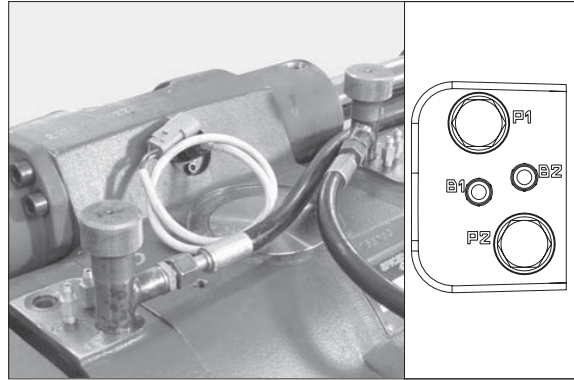

7409RAX193

- (2) Sling the arm to be removed and connect it to a hoist.
Loosen and remove screws (31).

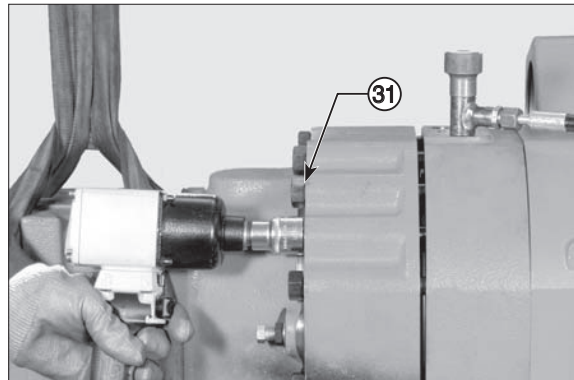

7409RAX194

- (3) Remove arm together with brakes and axle shafts; lay down the arm vertically.
Release pressure.

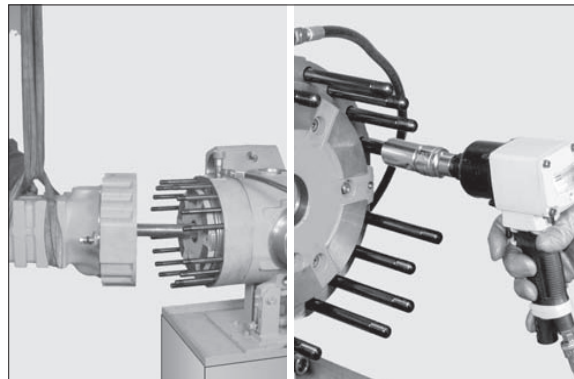

7409RAX195

- (4) Remove the reversal springs (13)

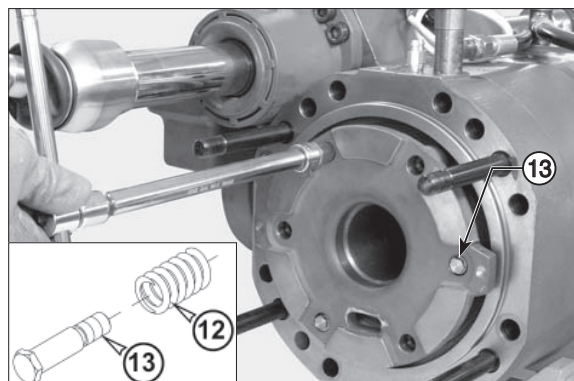

7409RAX196

- (5) Remove the adjusting screws (21) from the counterwasher (23).

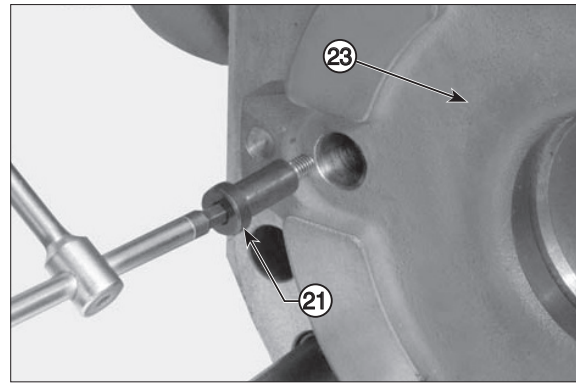

7409RAX197

- (6) Note down their order of assembly and remove the counterwasher (23).

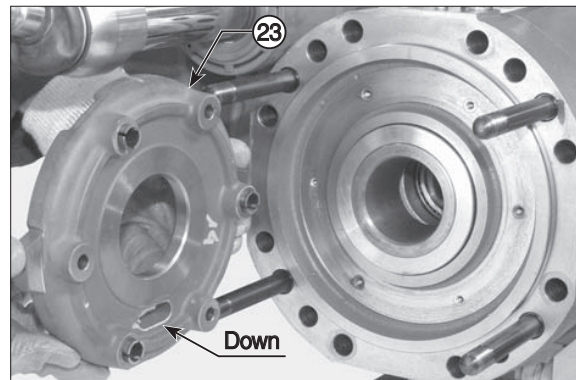

7409RAX198

- (7) Loosen the studs in an alternate manner and remove them.

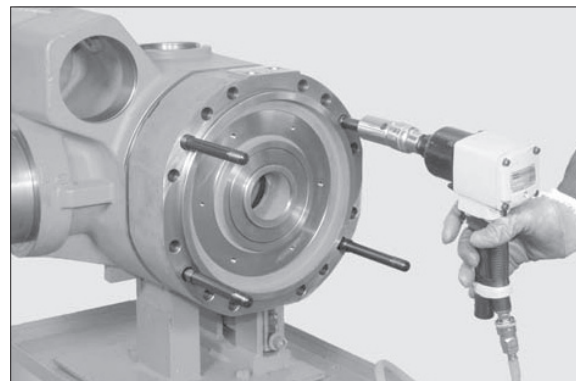

7409RAX199

- (8) Remove the cylinder (24).

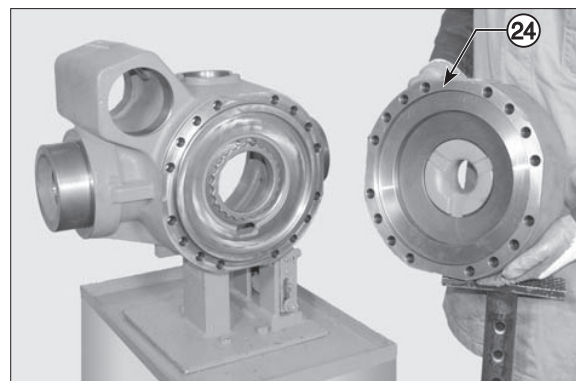

7409RAX200

(9) Remove the centering device (26) in the cylinder.

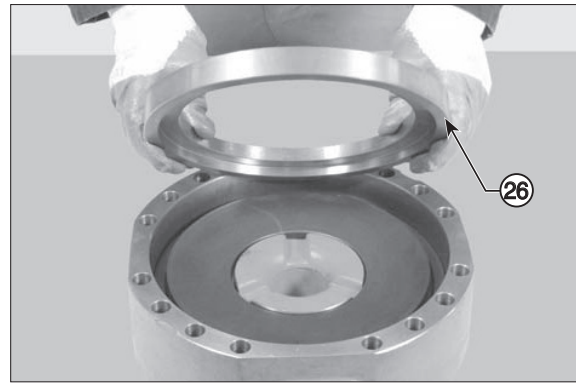

7409RAX201

(10) Remove the Belleville washers (1).

※ Check the sense of direction of washers (1).

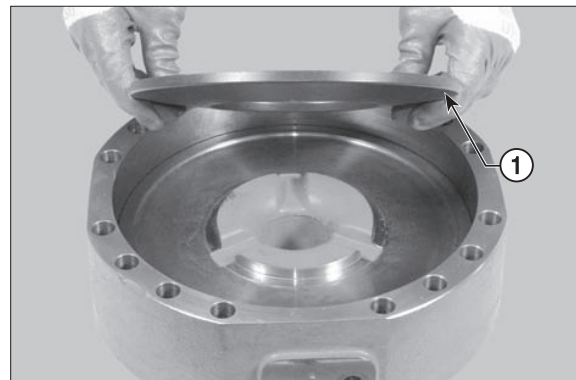

7409RAX202

※ The O-rings (2) must be replaced each time the unit is disassembled.

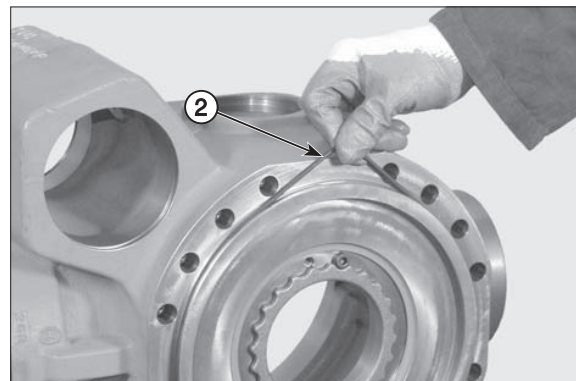

7409RAX203

(11) Slowly introduce low-pressure compressed air through the connection member for the service brake (P2), in order to extract the piston (11).

※ Hold the piston (11) back, as it may be suddenly ejected and damaged.

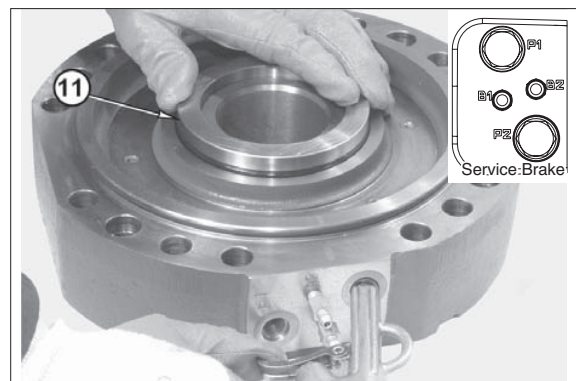

7409RAX204

(12) Note down their order of assembly.

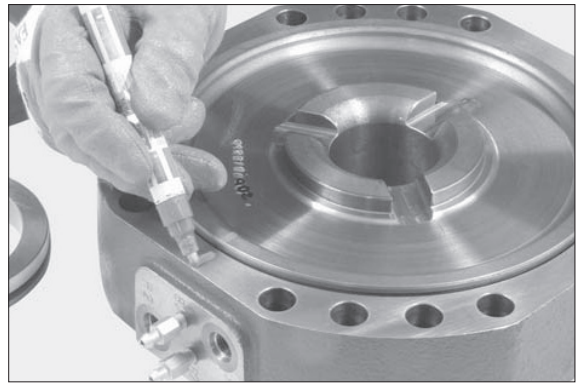

7409RAX205

(13) Slowly introduce low-pressure compressed air through the connection member for the service brake (P1), in order to extract the piston (3).

※ Hold the piston (3) back, as it may be suddenly ejected and damaged.

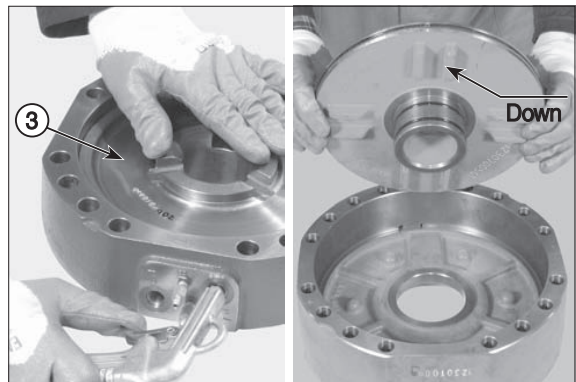

7409RAX206

(14) Remove braking discs (14)(15)(16), noting down direction of assembly.

※ If disks are not to be replaced, avoid changing their position.

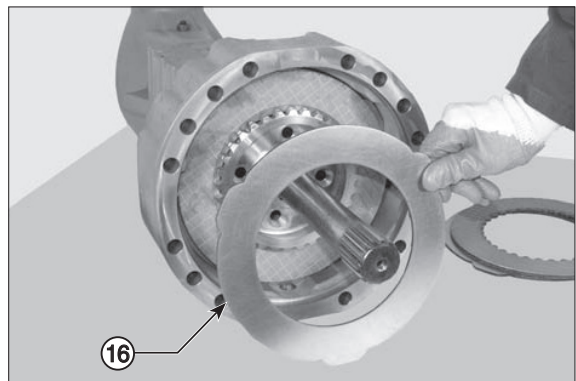

7409RAX207

(15) Remove the flange (17) complete with the discs (20)(19)(18).

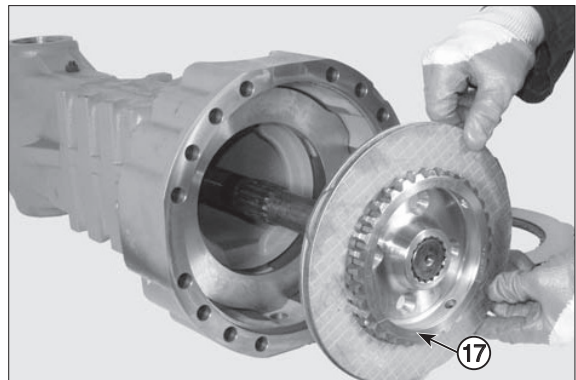

7409RAX208

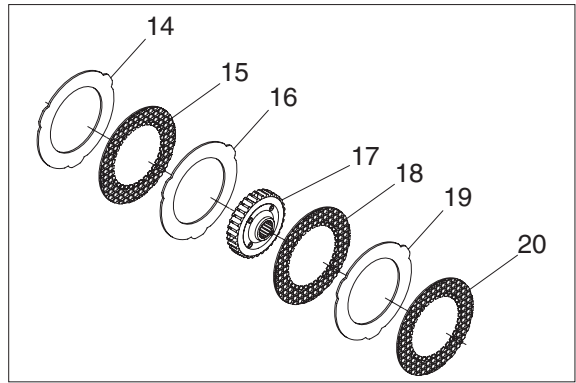

7409RAX209

(16) Remove distance piece-braking discs (27) and shims (28), noting down direction of assembly.

※ Build a stack of washers and check the measure.

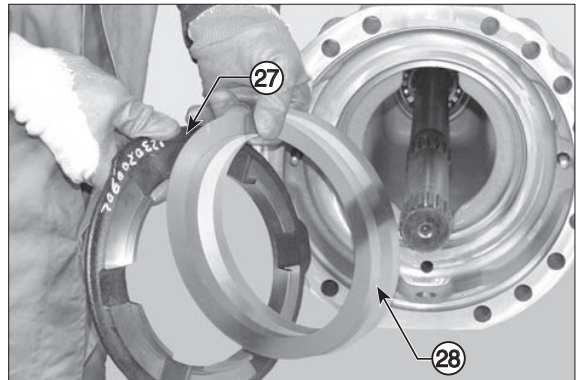

7409RAX210

13) NEGATIVE BRAKE : ASSEMBLING

SERVICE BRAKE AND SAHR

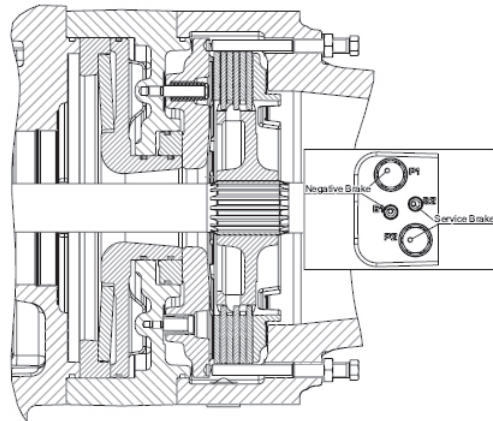

7409RAX211

SERVICE BRAKE

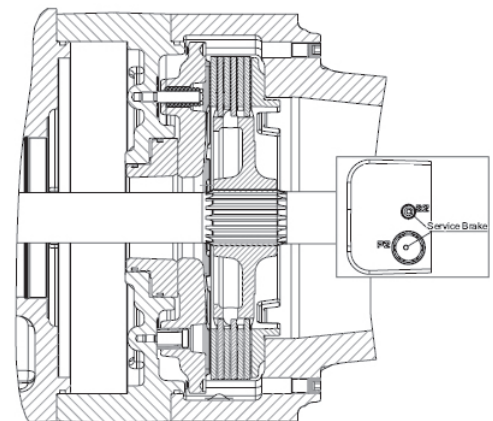

7409RAX212

Fix quote = 74.00 mm

Y = brake gap = 0.75 mm - 1.00 mm - 1.25 mm - 1.70 mm
(depending on axle configuration)

X = intermediate disc distance example = 29.00 mm

V = brake discs pack example = 42.33 mm

S = adjust. shims = 74 mm - (x + y + v) =

example =
74 - (29 + 1.25 + 42.33)
= 74 - 72.58
= 1.42 mm = S

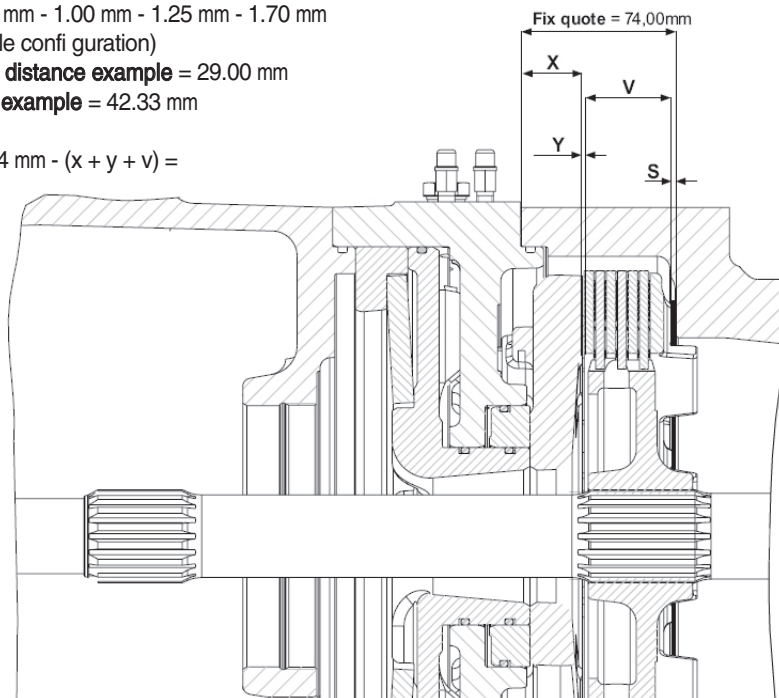

7409RAX213

(1) Complete the O-rings and anti-extrusion rings on all pistons.

※ The O-rings always have to be assembled from the pressure facing side.

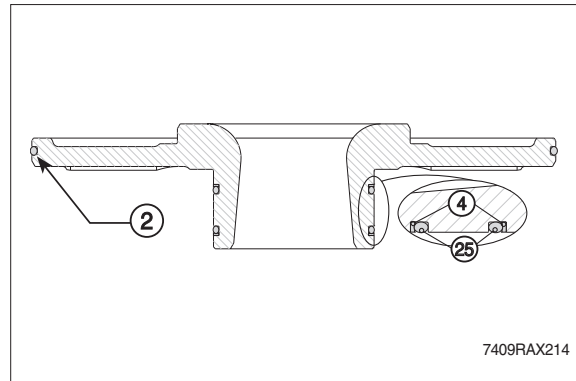

(2) Check the position of the anti-extrusion (4) and O-rings (2) (25).

Lubricate the piston and the O-rings and install the unit (3) into the cylinder (24) .

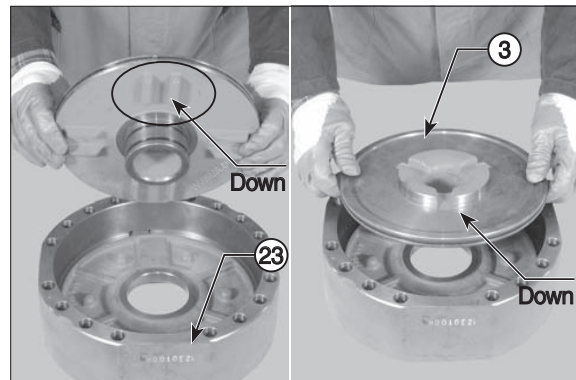

(3) Using a plastic hammer, ram the piston (3) into the cylinder (24).

※ Lightly hammer all around the edge in an alternate sequence.

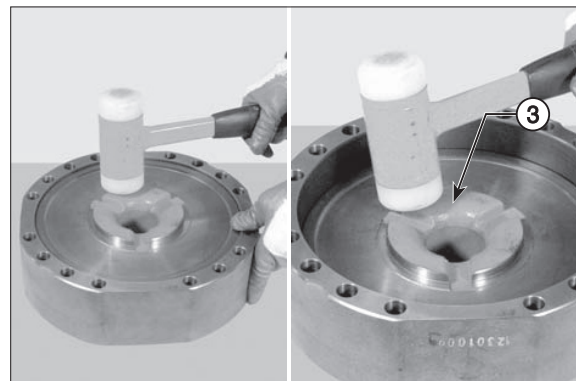

(4) Fit O-ring (9) and anti-extrusion ring (10) onto the piston (11).

Lubricate the piston and the O-rings and install the unit into the cylinder (24).

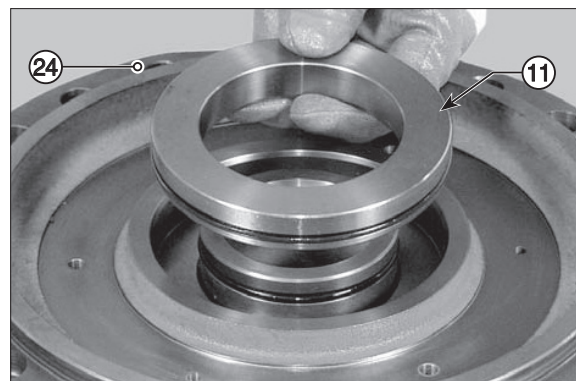

- ※ The O-rings always have to be assembled from the pressure facing side.

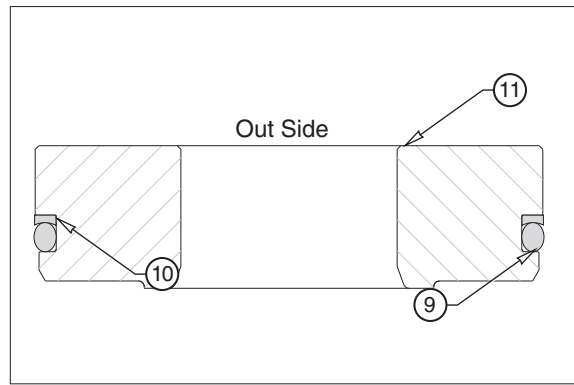

- (6) Using a plastic hammer, ram the piston (11) into the cylinder (24).
- ※ Lightly hammer all around the edge in an alternate sequence.

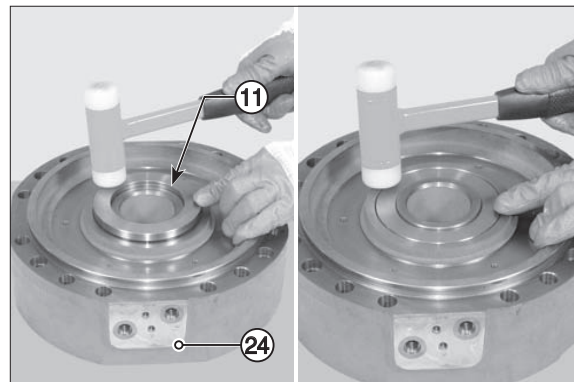

- (7) Position the belleville washers (1) and engage the cylinder (24).
- ※ Check the sense of direction of belleville washers (1) and relative centering.

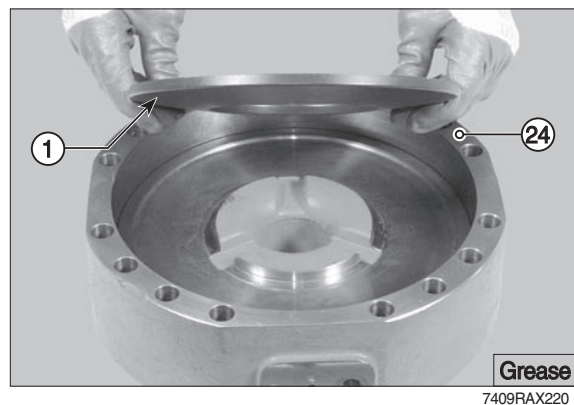

- (8) Install the centering device (26) in the cylinder.

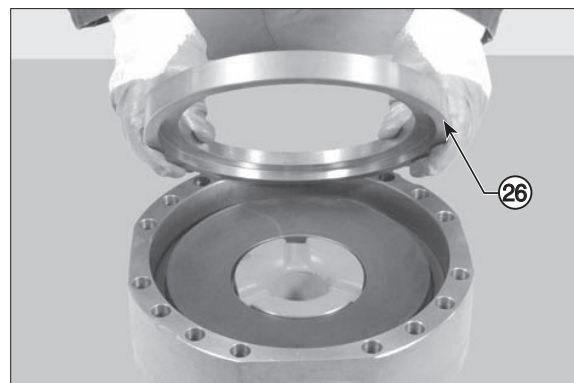

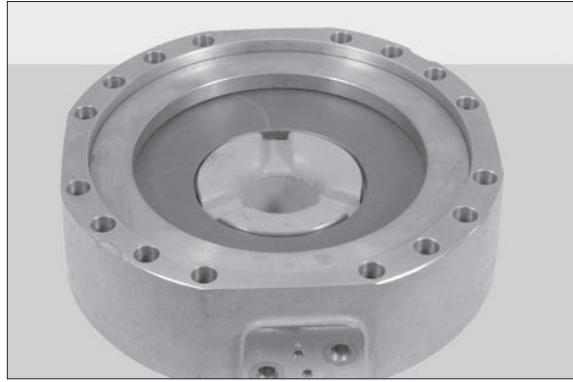

7409RAX222

(9) Check integrity and position of the cylinder's O-ring (2).

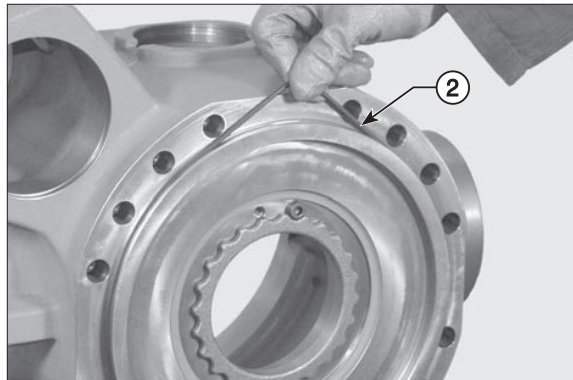

7409RAX223

(10) Engage the cylinder (24).

※ Check the sense of direction of washers (1) and relative centering.

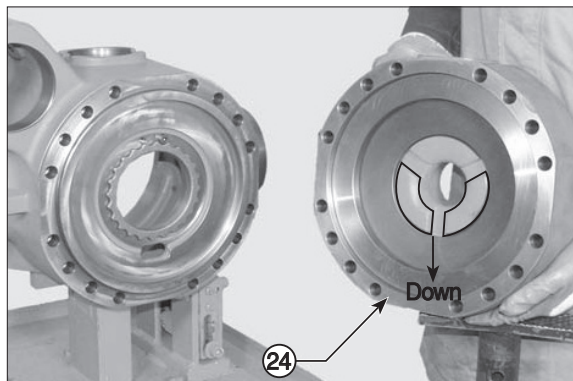

7409RAX224

(11) Insert the screws and tighten them alternately.
Lock the cylinder.

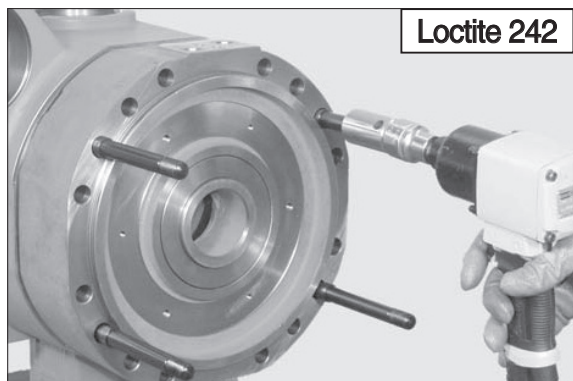

7409RAX225

(12) Tightening the studs with a dynamometric wrench set to a torque of 3.06~3.57 kgf · m (22.1~25.8 lbf · ft).

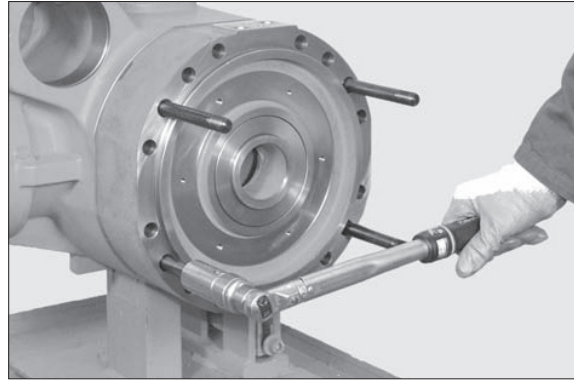

7409RAX226

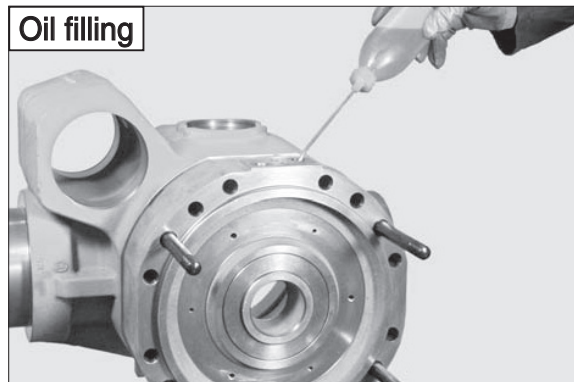

7409RAX227

(13) Connect an external pump to the negative brake and introduce pressure to 21.4~35.7 kgf/cm² (304~508 psi).

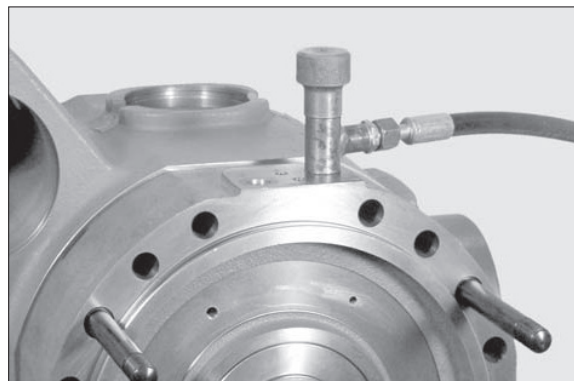

7409RAX228

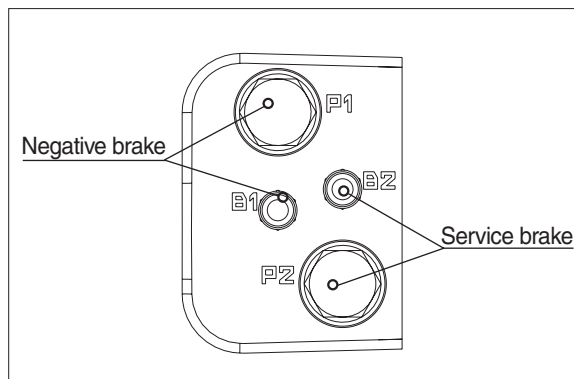

7409RAX229

- (14) Insert the stroke automatic regulation springs (22); place them in line with the piston (23).

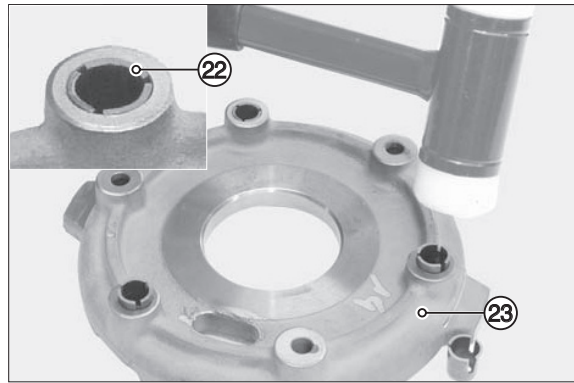

7409RAX230

- (15) Insert the intermediate disk (23).



7409RAX231

- (16) Fit the reversal springs (12)(13) on the intermediate disk (23).

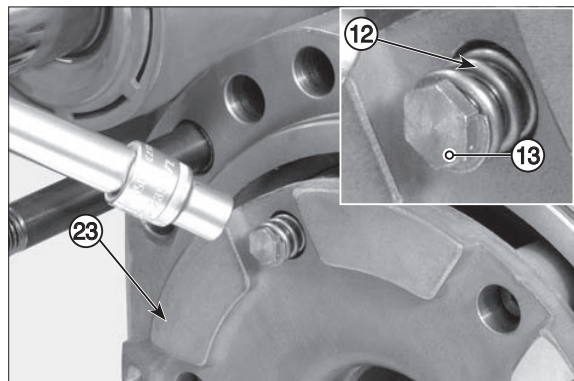

7409RAX232

- (17) Apply loctite 242 to the thread of the adjustment screw.
Tighten with torque wrench setting of 1.02~1.53 kgf · m (7.38~11.1 lbf · ft).

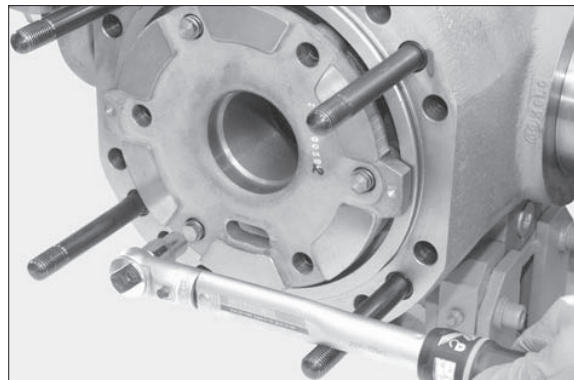

7409RAX233

- (18) Y=brake gap
 (0.75 mm 1.00 mm 1.25 mm 1.50 mm)
 depending on axle configuration.

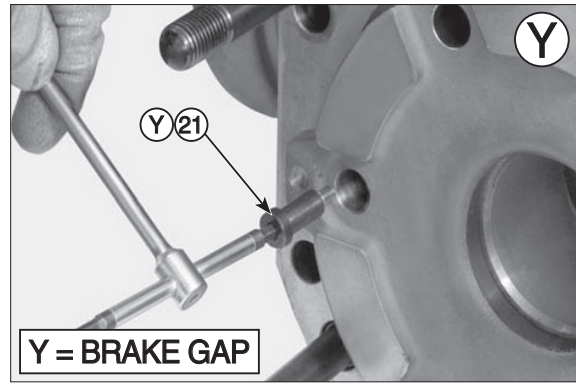

7409RAX234

- (19) Fit the pin screws.
 Apply loctite 270 to the thread.
- Torque wrench setting :
 0.51~0.71 kgf · m (3.69~5.16 lbf · ft)

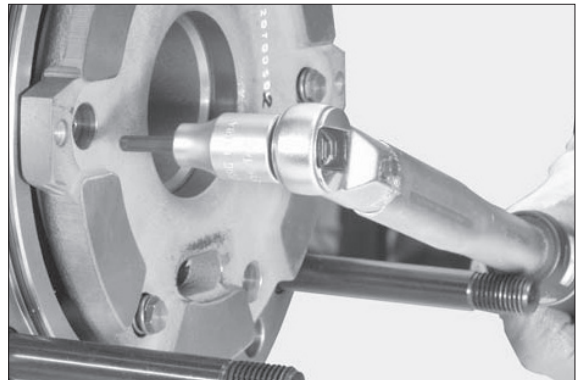

7409RAX235

- (20) Take the measure from the surface of the intermediate disk to the cover sealing surface with 30.6 kg/cm² (435 psi) of pressure introduced.

Example : 29 mm

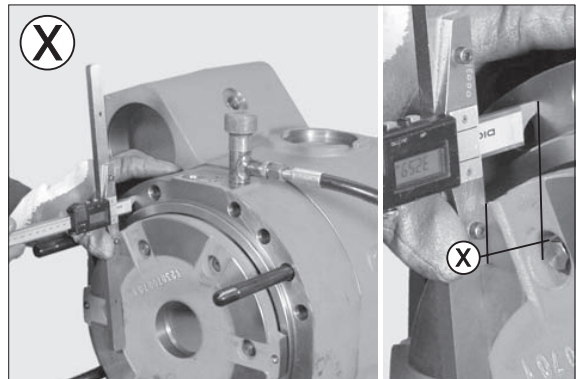

7409RAX236

- (21) Put the brake disc pack including the shim under a press, load with 1000 kg and take the measure "V".

Example : V = 42.33 mm

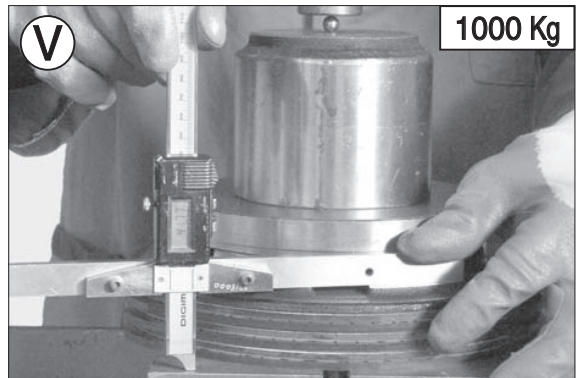

7409RAX237

(22) Arm fix quote = 74 mm

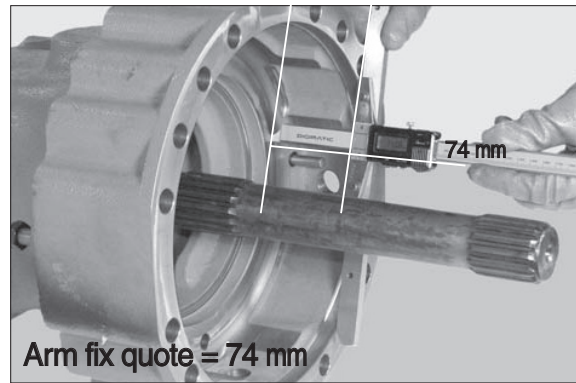

7409RAX238

(23) $S = 74 \text{ mm} - (x + y + v)$ = Thickness of shims to insert under the shim washer.

Example :

$$74 \text{ mm} - (29 + 42.33 + 1.25) = S = 1.42 \text{ mm}$$

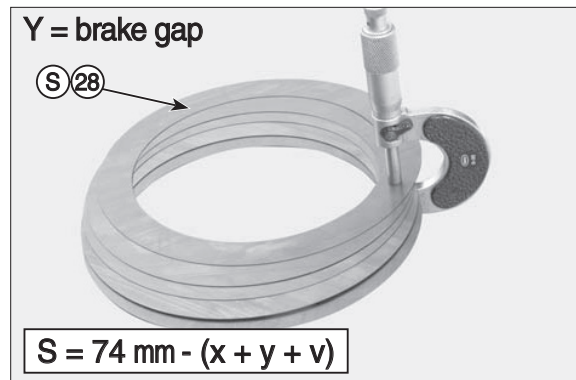

7409RAX239

(24) Insert under the shim washer a thickness of shims (28).

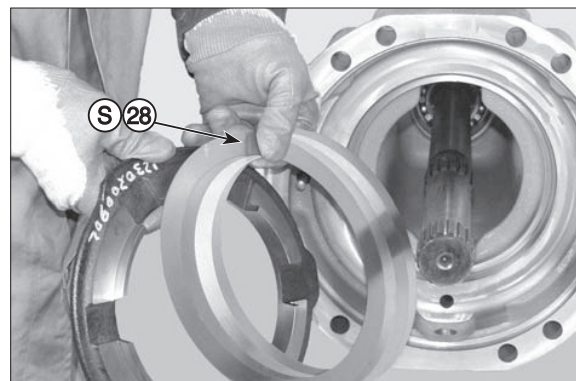

7409RAX240

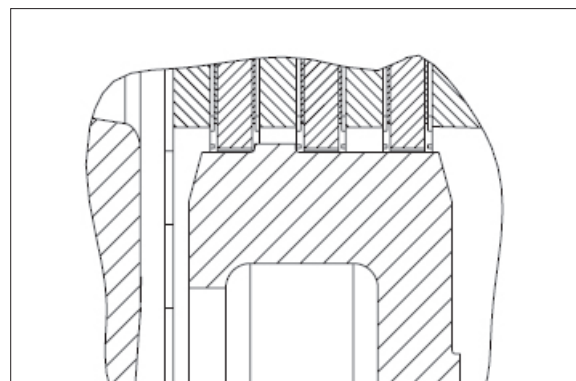

7409RAX241

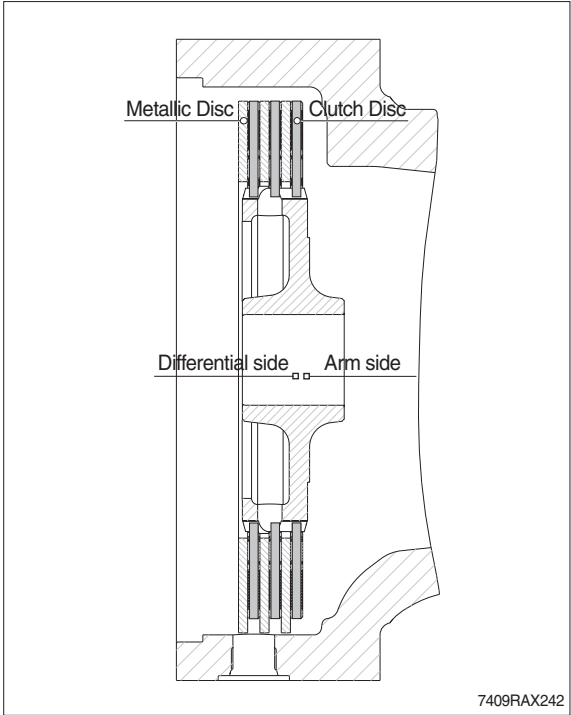

(25) Install the friction disc (18) on the flange (17) from arm side.

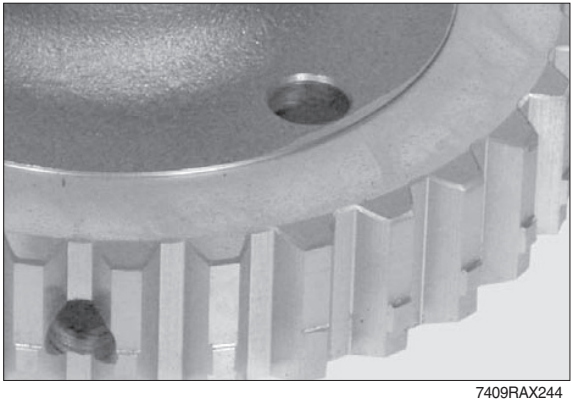
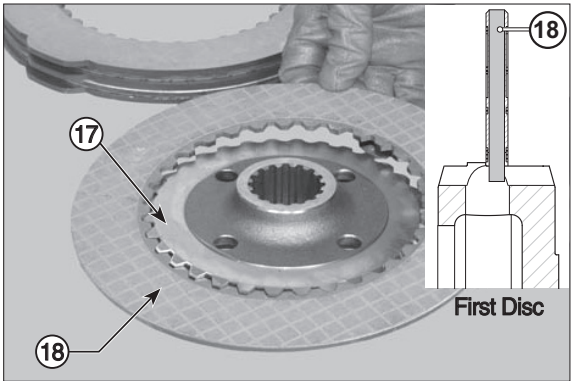

(26) Install the metal disc (19) on the flange (17) from arm side.

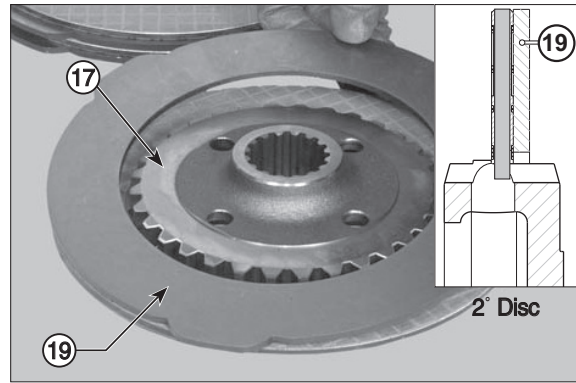

(27) Install the friction disc (18) on the flange from arm side and insert the group on the u-joint.

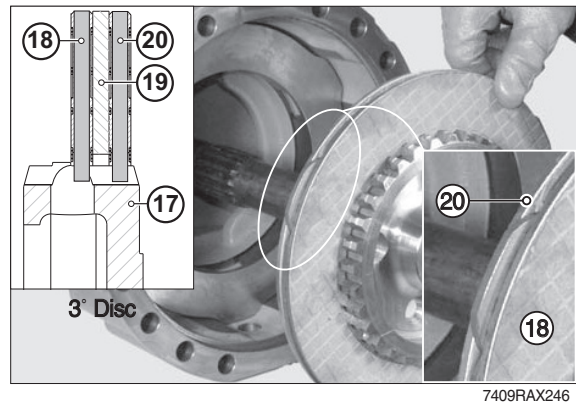

(28) Insert on the flange the discs (16)(15) (14).

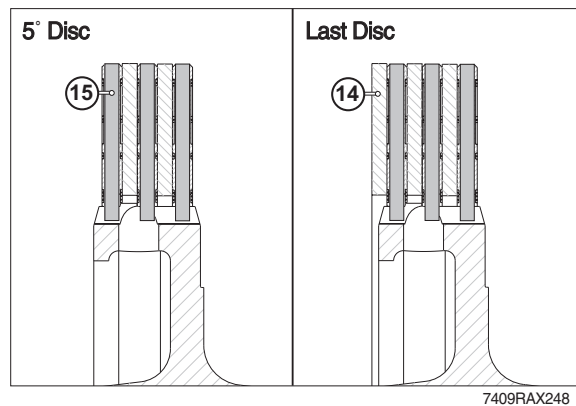
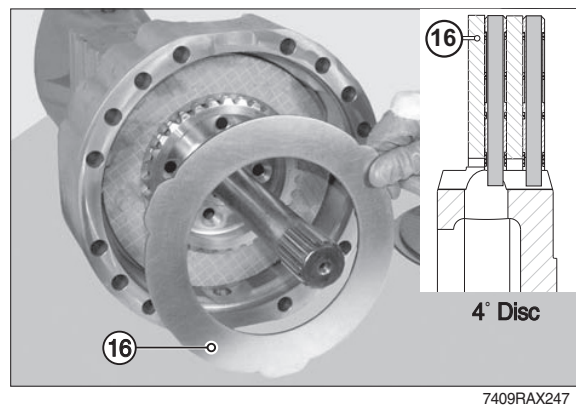

(29) Check the alignment of last disc (14) and flange.

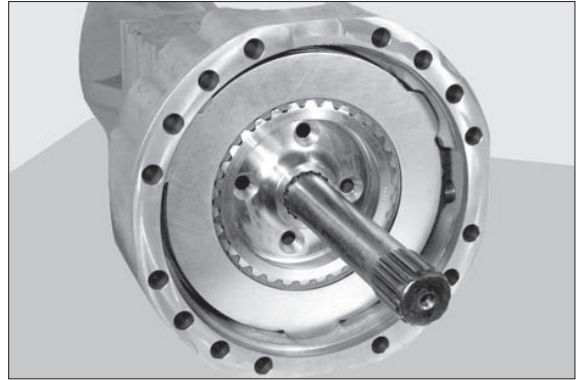

7409RAX249

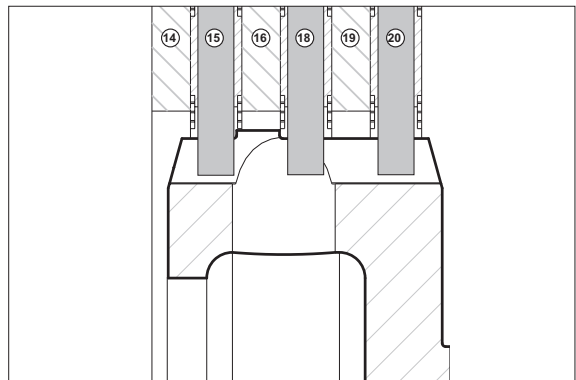

7409RAX250

(30) Apply loctite 242 to the studs and tighten it using a dynamometric wrench.

- Torque wrench setting :
3.06~3.57 kgf · m (22.1~25.8 lbf · ft)

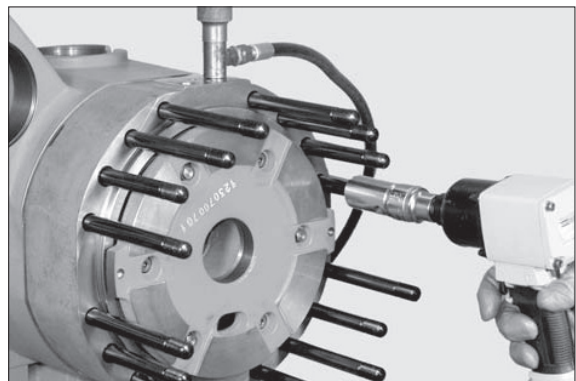

7409RAX251

(31) Check integrity and position of the cylinder's O-ring.

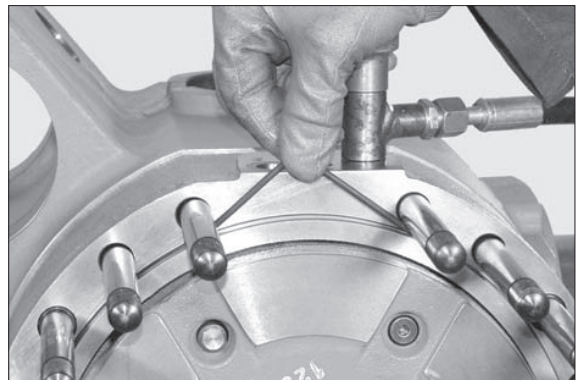

7409RAX252

(32) Check integrity and position of the arm's O-ring; install the complete arm.

※ To assist axle shaft centering, slightly move the wheel hub.

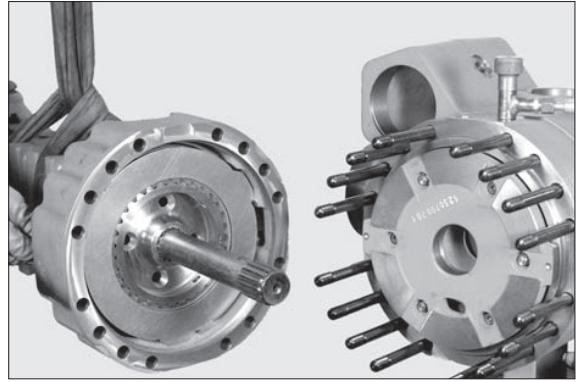

7409RAX253

(33) Apply loctite 242 to the nuts and cross tighten it in two stages.

- Torque wrench setting :
20.4~22.5 kgf · m (148~163 lbf · ft)

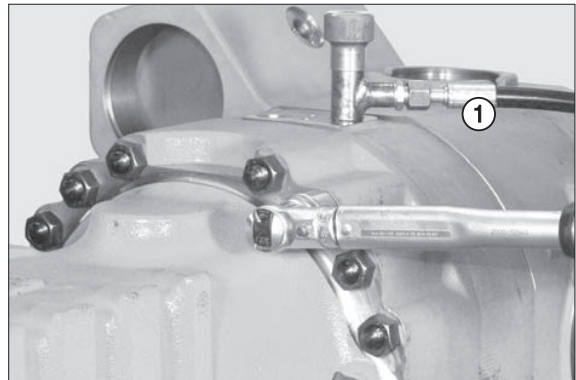

7409RAX254