

SECTION 2 ENGINE

Group 1 Structure and Function	2-1
Group 2 Fuel warmer system	2-7
Group 3 Engine speed and Stall rpm	2-8

SECTION 2 ENGINE

GROUP 1 STRUCTURE AND FUNCTION

1. STRUCTURE

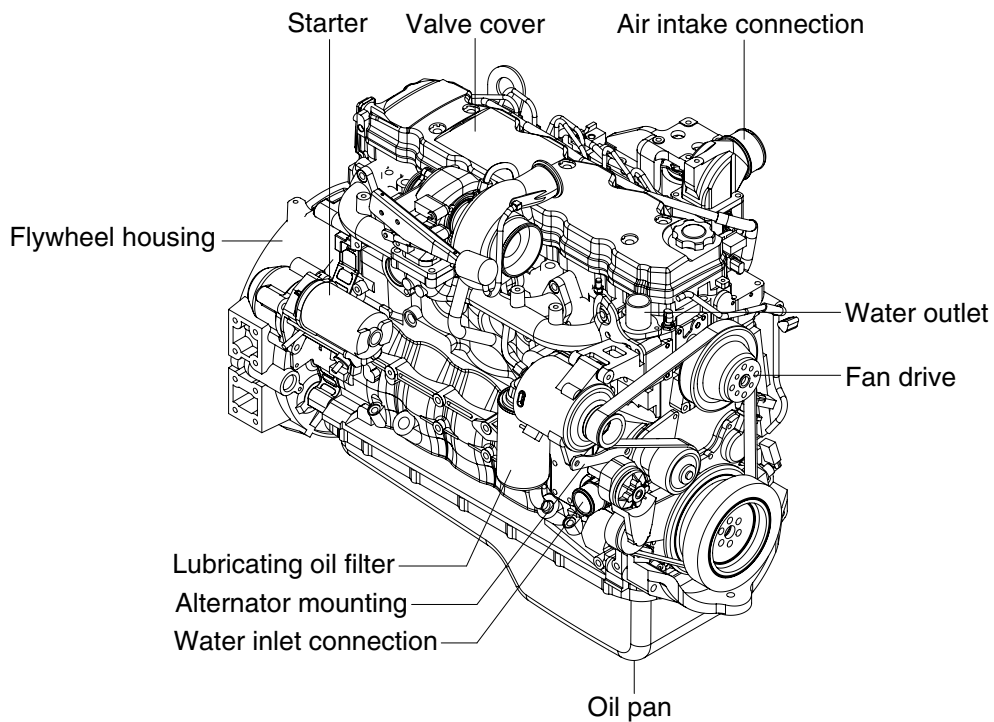
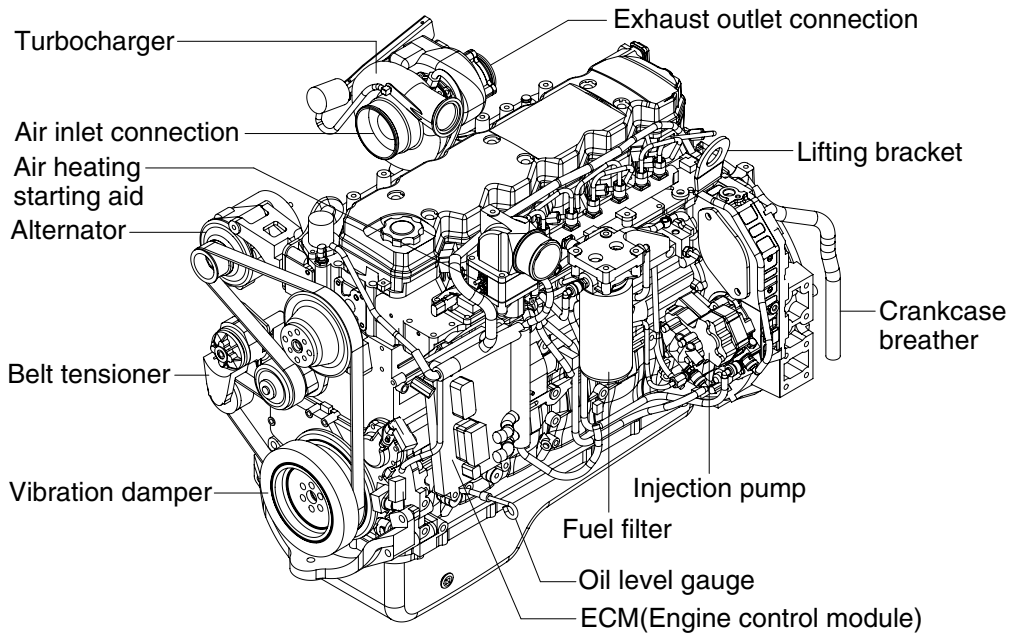

7577AEG01

- Direct 4-stroke, 6-cylinders, water-cooling and charge air cooled diesel engine in installed, cylinder block and cylinder head are made of case iron and turbocharger is attached.

2. SYSTEM DIAGRAMS

The following drawings show the flow through the engine systems.

1) FUEL SYSTEM

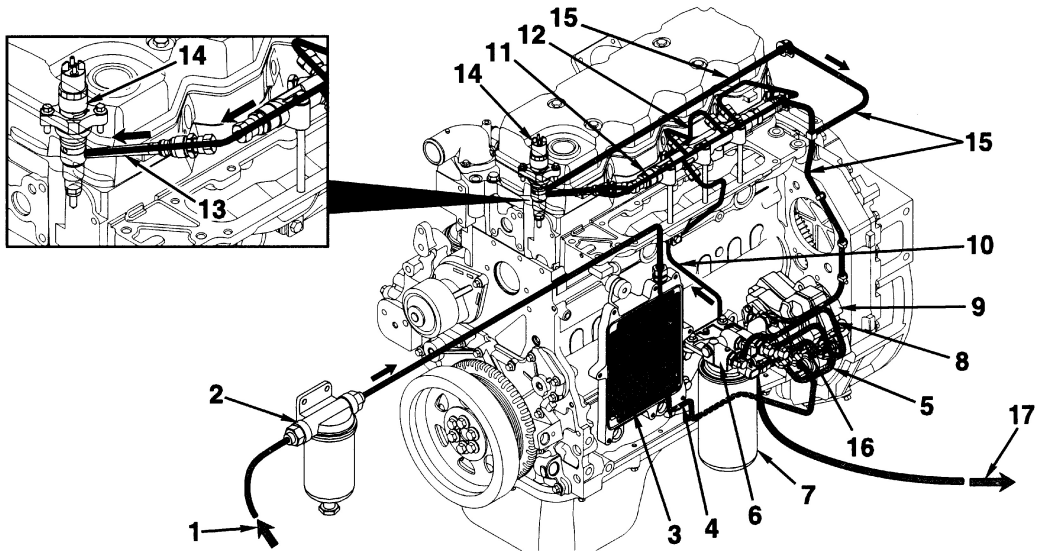

7607AEG02

- | | | | |
|----|--|----|--|
| 1 | From fuel tank | 11 | Fuel rail |
| 2 | Water/fuel separator (not mounted on engine) | 12 | To injectors |
| 3 | ECM cooling plate | 13 | High-pressure connector |
| 4 | To fuel gear pump | 14 | Injector |
| 5 | To fuel filter | 15 | Fuel return from injectors and fuel rail to fuel filter head |
| 6 | Fuel filter head | 16 | Fuel return from high-pressure pump to fuel filter head |
| 7 | Fuel filter | 17 | To fuel tank |
| 8 | To high-pressure pump | | |
| 9 | High-pressure pump | | |
| 10 | To fuel rail | | |

2) LUBRICATING OIL SYSTEM

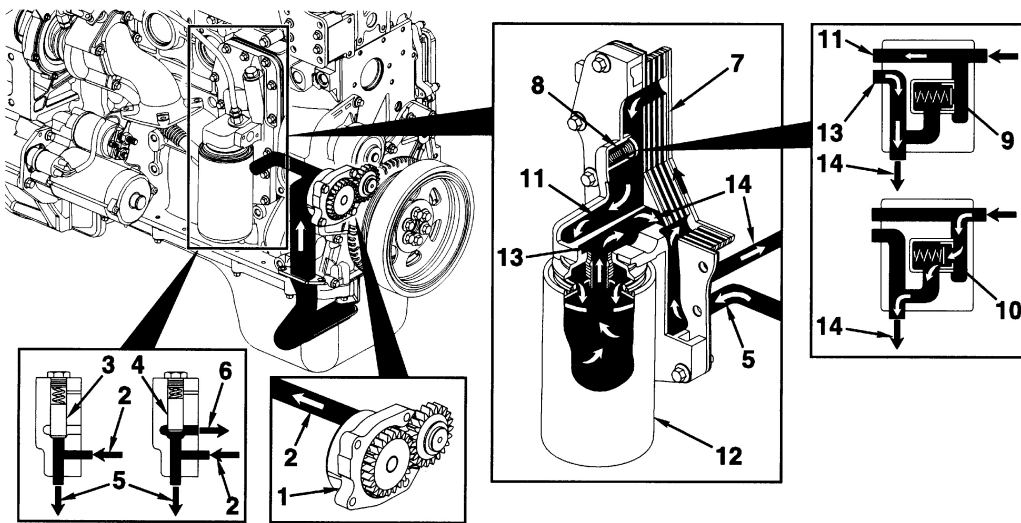

7607AEG03

- | | |
|------------------------------------|-------------------------------------|
| 1 Gerotor lubricating oil pump | 8 Filter bypass valve |
| 2 From lubricating oil pump | 9 Filter bypass valve closed |
| 3 Pressure regulating valve closed | 10 Filter bypass valve open |
| 4 Pressure regulating valve open | 11 To lubricating oil filter |
| 5 To lubricating oil cooler | 12 Full-flow lubricating oil filter |
| 6 To lubricating oil pump supply | 13 From lubricating oil filter |
| 7 Lubricating oil cooler | 14 Main lubricating oil rifle |

(1) Lubrication for the turbocharger

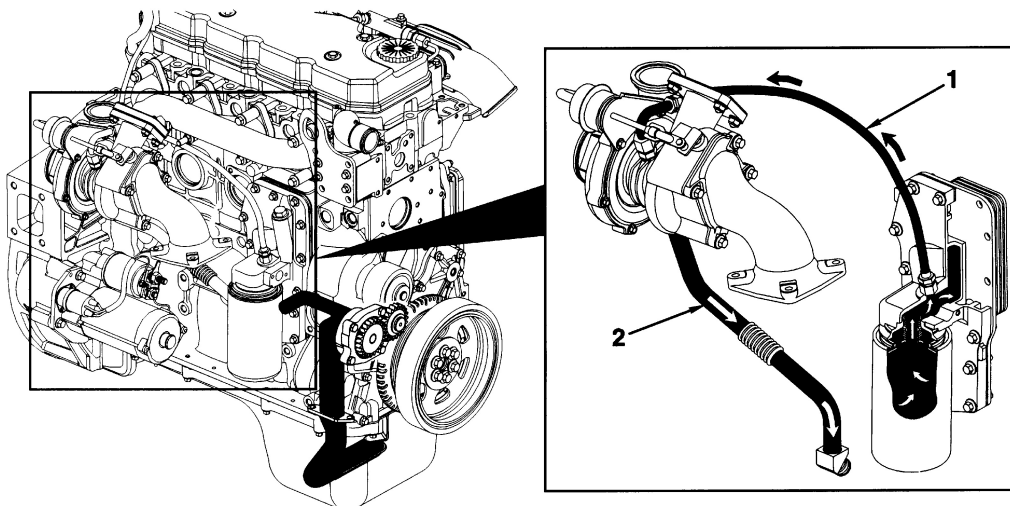

7607AEG04

- | | |
|---------------------------------------|--------------------------------------|
| 1 Turbocharger lubricating oil supply | 2 Turbocharger lubricating oil drain |
|---------------------------------------|--------------------------------------|

(2) Lubrication for the power components

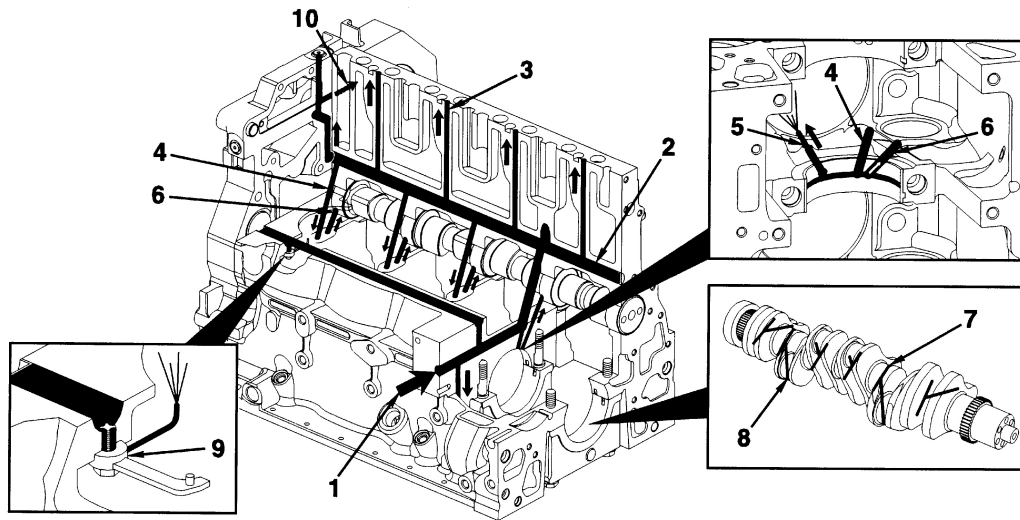

7607AEG05

- | | | | |
|---|---------------------------------|----|---|
| 1 | From lubricating oil cooler | 6 | To camshaft |
| 2 | Main lubricating oil rifle | 7 | Crankshaft main journal |
| 3 | To valve train | 8 | Oil supply to rod bearings |
| 4 | From main lubricating oil rifle | 9 | Directed piston-cooling nozzle |
| 5 | To piston-cooling nozzle | 10 | To internal lubrication of air compressor |

(3) Lubrication for the overhead

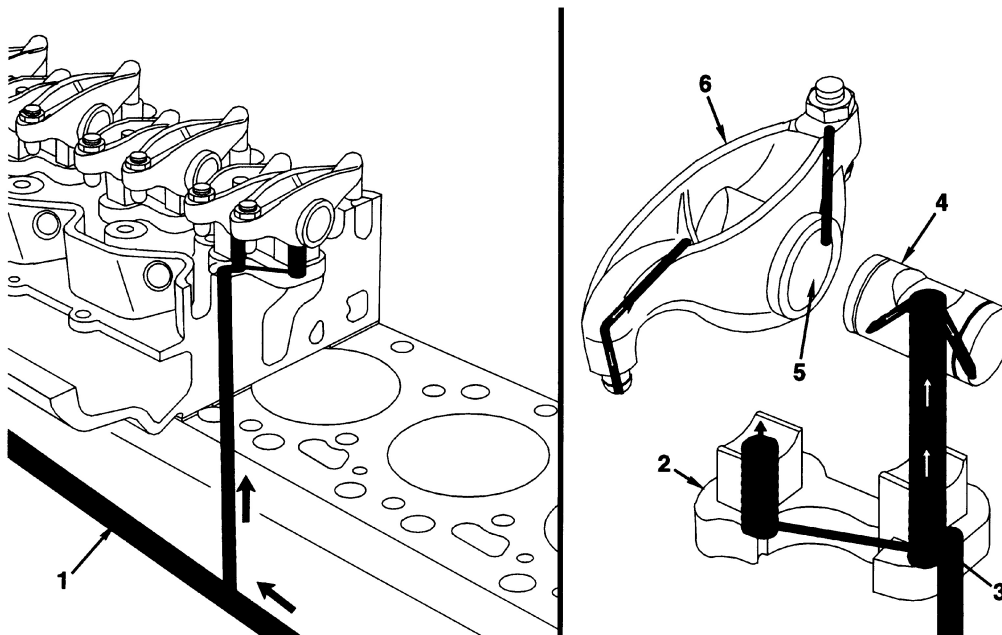

7607AEG06

- | | | | |
|---|----------------------------|---|--------------------|
| 1 | Main lubricating oil rifle | 4 | Rocker lever shaft |
| 2 | Rocker lever support | 5 | Rocker lever bore |
| 3 | Transfer slot | 6 | Rocker lever |

3) COOLING SYSTEM

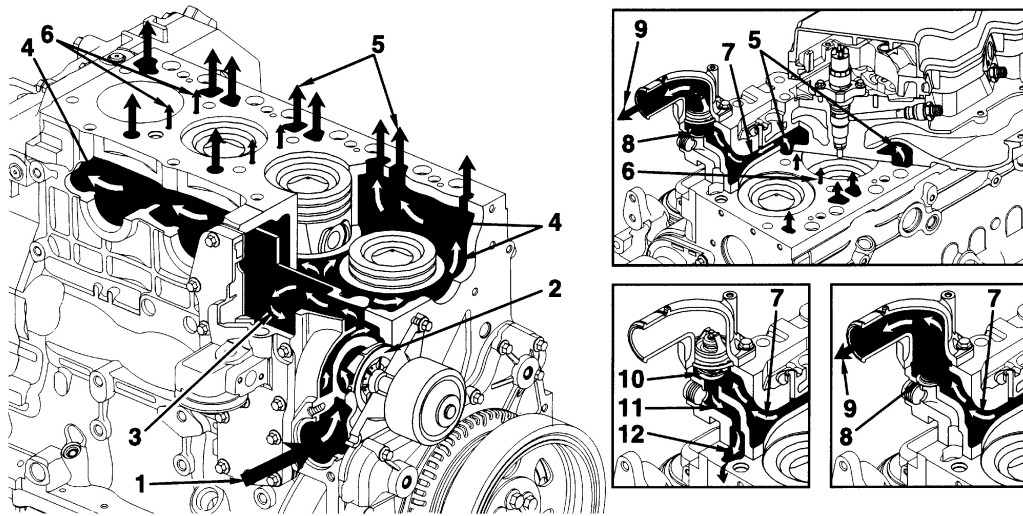

7607AEG07

- | | | | |
|---|---|----|------------------------------------|
| 1 | Coolant inlet | 7 | Coolant flow to thermostat housing |
| 2 | Pump Impeller | 8 | Coolant bypass passage |
| 3 | Coolant flow past lubricating oil cooler | 9 | Coolant flow back to radiator |
| 4 | Coolant flow past cylinders | 10 | Bypass closed |
| 5 | Coolant flow from cylinder block to cylinder head | 11 | Coolant bypass in cylinder head |
| 6 | Coolant flow between cylinders | 12 | Coolant flow to water pump inlet |

4) AIR INTAKE SYSTEM

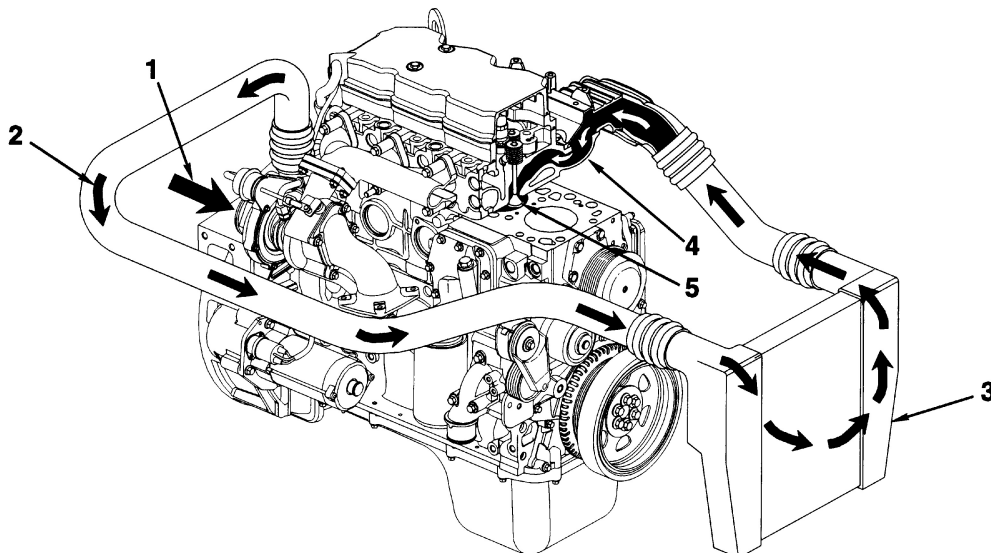

7607AEG08

- | | | | |
|---|---------------------------------------|---|---|
| 1 | Intake air inlet to turbocharger | 4 | Intake manifold
(Integral part of cylinder head) |
| 2 | Turbocharger air to charge air cooler | 5 | Intake valve |
| 3 | Charge air cooler | | |

5) EXHAUST SYSTEM

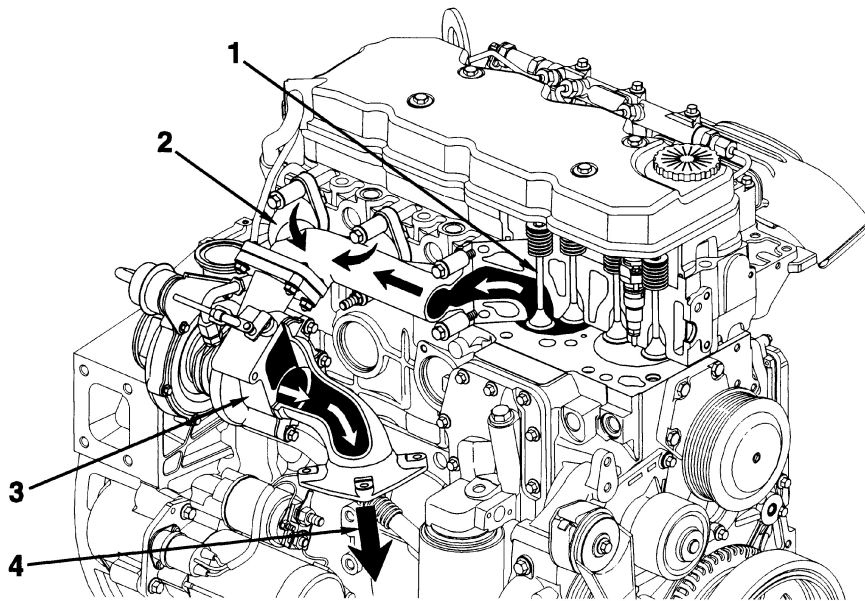

7607AEG09

- | | | | |
|---|------------------|---|-----------------------------|
| 1 | Exhaust valve | 3 | Turbocharger |
| 2 | Exhaust manifold | 4 | Turbocharger exhaust outlet |