

## GROUP 2 SPECIFICATION

### 1. MAJOR COMPONENT (HL740-9, HL740XTD-9)

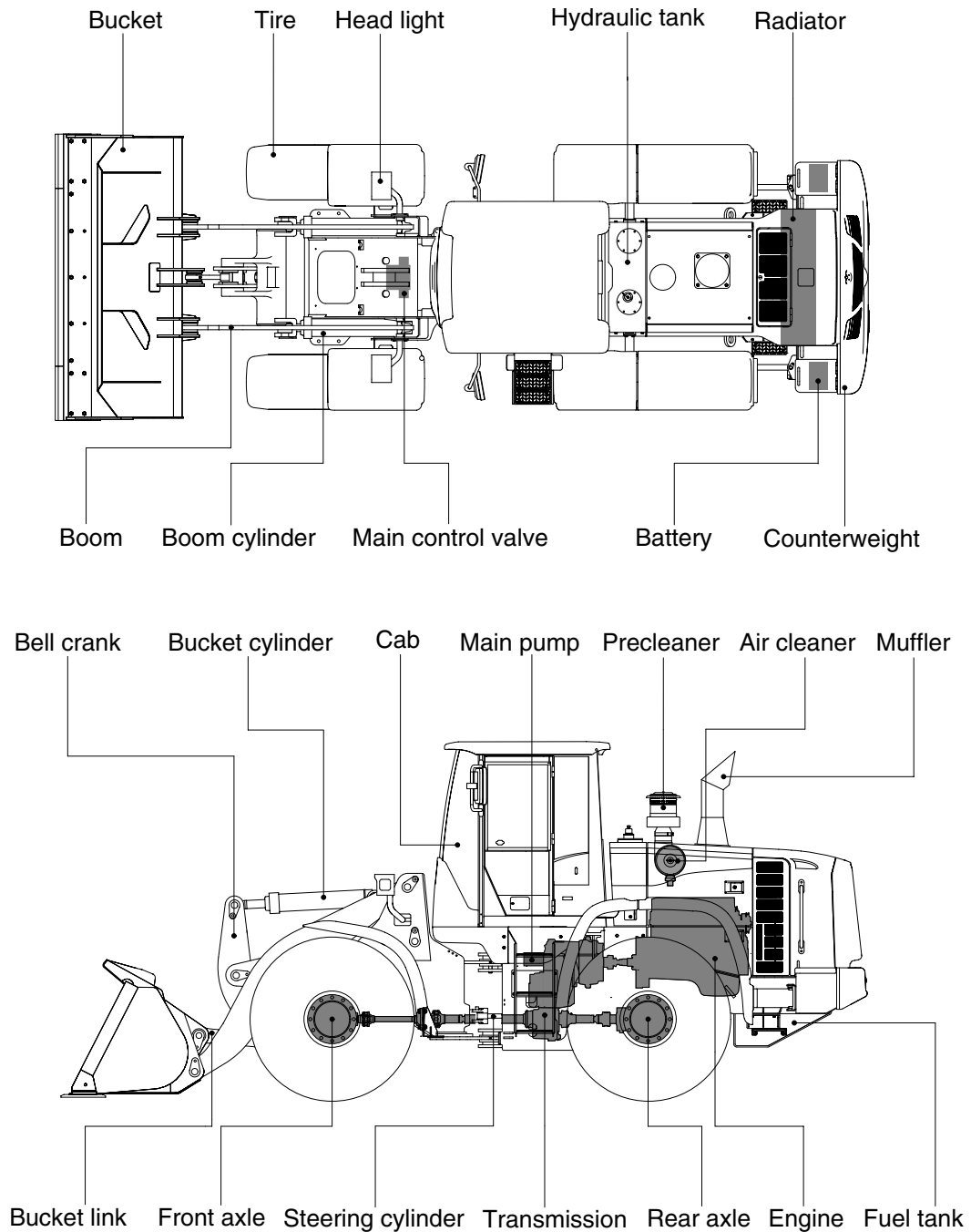

74092SP05

# MAJOR COMPONENT (HL740TM-9)

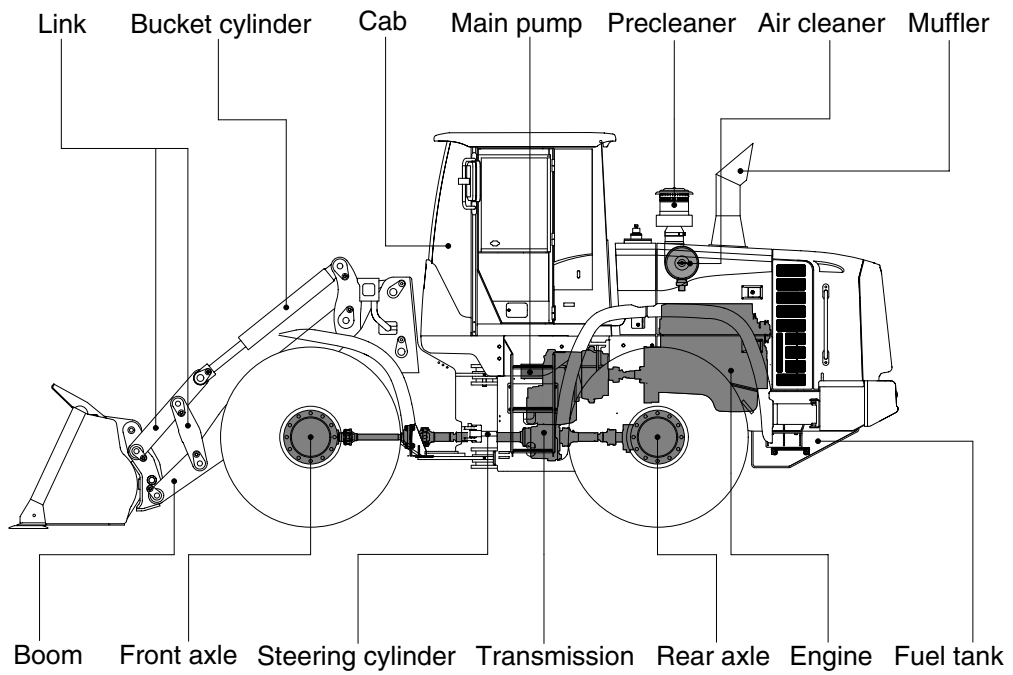
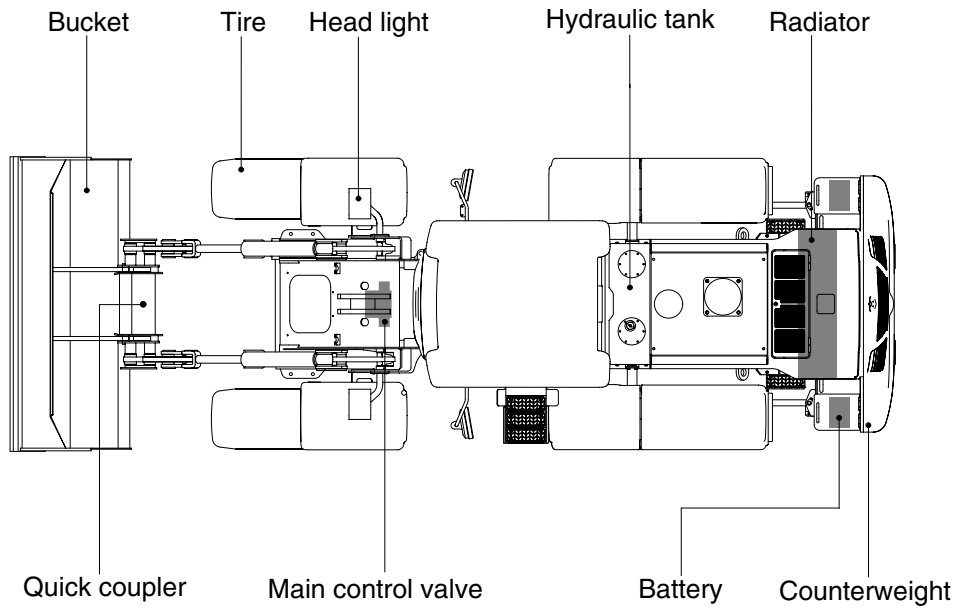

740TM92SP05

## 2. SPECIFICATIONS

### 1) WITH BOLT-ON CUTTING EDGE TYPE BUCKET (HL740-9)

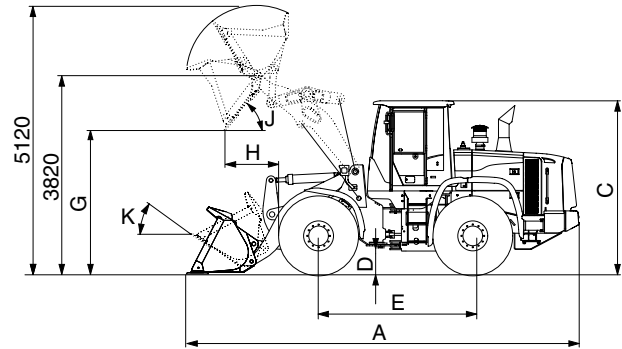
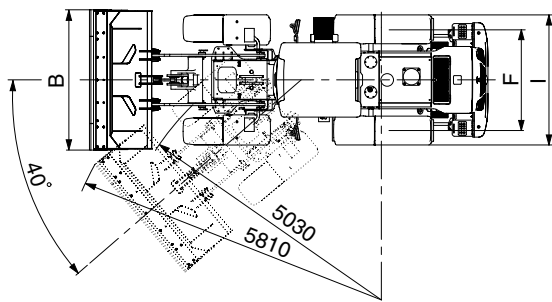

74092SP01

Description		Unit	Specification	
Operating weight		kg (lb)	12000 (26460)	
Bucket capacity	Struck	m <sup>3</sup> (yd <sup>3</sup> )	2.0 (2.6)	
	Heaped		2.3 (3.0)	
Overall length	A	mm (ft-in)	7380 (24' 3")	
Overall width	B		2600 (8' 6")	
Overall height	C		3260 (10' 8")	
Ground clearance	D		417 (1' 4")	
Wheelbase	E		2900 (9' 6")	
Tread	F		1900 (6' 3")	
Dump clearance at 45°	G		2785 (9' 2")	
Dump reach (full lift)	H		1025 (3' 4")	
Width over tires	I		2430 (8' 0")	
Dump angle	J		degree (°)	48
Roll back angle (carry position)	K			47
Cycle time	Lift (with load)	sec	5.5	
	Dump (with load)		1.1	
	Lower (empty)		3.0	
Maximum travel speed		km/hr (mph)	39.0 (24.3)	
Braking distance		m (ft-in)	12 (39' 4")	
Minimum turning radius (center of outside tire)			5.03 (16' 6")	
Gradeability		degree (°)	30	
Travel speed	Forward	First gear	6.7 (4.2)	
		Second gear	12.2 (7.6)	
		Third gear	23.8 (14.8)	
		Fourth gear	39.0 (24.3)	
	Reverse	First gear	7.1 (4.4)	
		Second gear	12.9 (8.0)	
Third gear		25.1 (15.6)		

**WITH BOLT-ON CUTTING EDGE TYPE BUCKET (HL740XTD-9)**

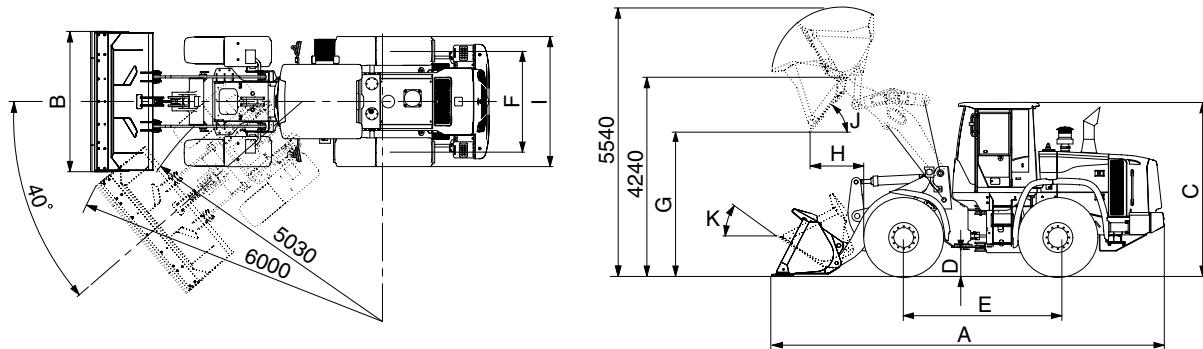

74092SP02

Description		Unit	Specification	
Operating weight		kg (lb)	12300 (27100)	
Bucket capacity	Struck	m <sup>3</sup> (yd <sup>3</sup> )	2.0 (2.6)	
	Heaped		2.3 (3.0)	
Overall length	A	mm (ft-in)	7830 (25' 8")	
Overall width	B		2600 (8' 6")	
Overall height	C		3260 (10' 8")	
Ground clearance	D		417 (1' 4")	
Wheelbase	E		2900 (9' 6")	
Tread	F		1900 (6' 3")	
Dump clearance at 45°	G		3210 (10' 6")	
Dump reach (full lift)	H		1020 (3' 4")	
Width over tires	I		2430 (8' 0")	
Dump angle	J		degree (°)	47
Roll back angle (carry position)	K			49
Cycle time	Lift (with load)	sec	5.5	
	Dump (with load)		1.1	
	Lower (empty)		3.0	
Maximum travel speed		km/hr (mph)	39.0 (24.3)	
Braking distance		m (ft-in)	12 (39' 4")	
Minimum turning radius (center of outside tire)			5.03 (16' 6")	
Gradeability		degree (°)	30	
Travel speed	Forward	First gear	6.7 (4.2)	
		Second gear	12.2 (7.6)	
		Third gear	23.8 (14.8)	
		Fourth gear	39.0 (24.3)	
	Reverse	First gear	7.1 (4.4)	
		Second gear	12.9 (8.0)	
Third gear		25.1 (15.6)		

**WITH BOLT-ON CUTTING EDGE TYPE BUCKET (HL740TM-9)**

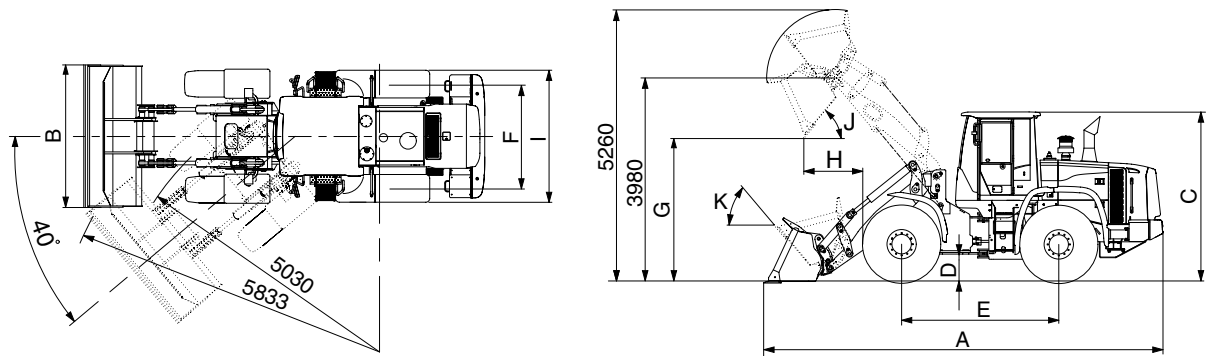

740TM92SP02

Description		Unit	Specification	
Operating weight		kg (lb)	12600 (27780)	
Bucket capacity	Struck	m <sup>3</sup> (yd <sup>3</sup> )	2.0 (2.6)	
	Heaped		2.3 (3.0)	
Overall length	A	mm (ft-in)	7660 (25' 2")	
Overall width	B		2550 (8' 4")	
Overall height	C		3260 (10' 8")	
Ground clearance	D		417 (1' 4")	
Wheelbase	E		2900 (9' 6")	
Tread	F		1900 (6' 3")	
Dump clearance at 45°	G		2840 (9' 4")	
Dump reach (full lift)	H		1330 (4' 4")	
Width over tires	I		2430 (8' 0")	
Dump angle	J		degree (°)	50
Roll back angle (carry position)	K			54
Cycle time	Lift (with load)	sec	5.5	
	Dump (with load)		1.6	
	Lower (empty)		3.0	
Maximum travel speed		km/hr (mph)	39.0 (24.3)	
Braking distance		m (ft-in)	12 (39' 4")	
Minimum turning radius (center of outside tire)			5.03 (16' 6")	
Gradeability		degree (°)	30	
Travel speed	Forward	First gear	6.7 (4.2)	
		Second gear	12.2 (7.6)	
		Third gear	23.8 (14.8)	
		Fourth gear	39.0 (24.3)	
	Reverse	First gear	7.1 (4.4)	
		Second gear	12.9 (8.0)	
Third gear		25.1 (15.6)		

## 2) WITH TOOTH TYPE BUCKET (HL740-9)

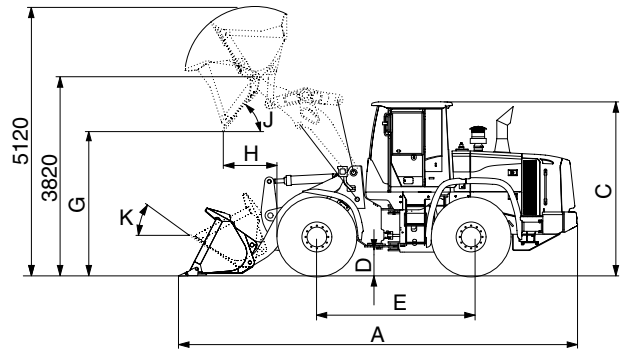
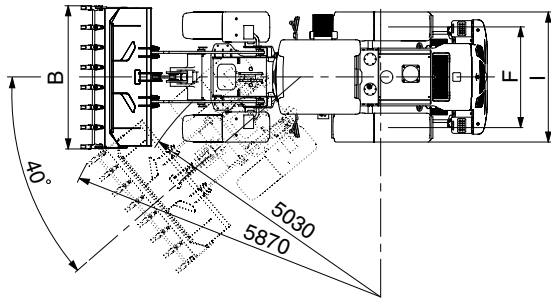

74092SP03

Description		Unit	Specification	
Operating weight		kg (lb)	12000 (26400)	
Bucket capacity	Struck	m <sup>3</sup> (yd <sup>3</sup> )	1.9 (2.5)	
	Heaped		2.2 (2.9)	
Overall length	A	mm (ft-in)	7500 (24' 7")	
Overall width	B		2650 (8' 8")	
Overall height	C		3260 (10' 8")	
Ground clearance	D		417 (1' 4")	
Wheelbase	E		2900 (9' 6")	
Tread	F		1900 (6' 3")	
Dump clearance at 45°	G		2695 (8' 10")	
Dump reach (full lift)	H		1100 (3' 7")	
Width over tires	I		2430 (8' 0")	
Dump angle	J		degree (°)	48
Roll back angle (carry position)	K			47
Cycle time	Lift (with load)	sec	5.5	
	Dump (with load)		1.1	
	Lower (empty)		3.0	
Maximum travel speed		km/hr (mph)	39.0 (24.3)	
Braking distance		m (ft-in)	12 (39' 4")	
Minimum turning radius (center of outside tire)			5.03 (16' 6")	
Gradeability		degree (°)	30	
Travel speed	Forward	First gear	6.7 (4.2)	
		Second gear	12.2 (7.6)	
		Third gear	23.8 (14.8)	
		Fourth gear	39.0 (24.3)	
	Reverse	First gear	7.1 (4.4)	
		Second gear	12.9 (8.0)	
Third gear		25.1 (15.6)		

**WITH TOOTH TYPE BUCKET (HL740XTD-9)**

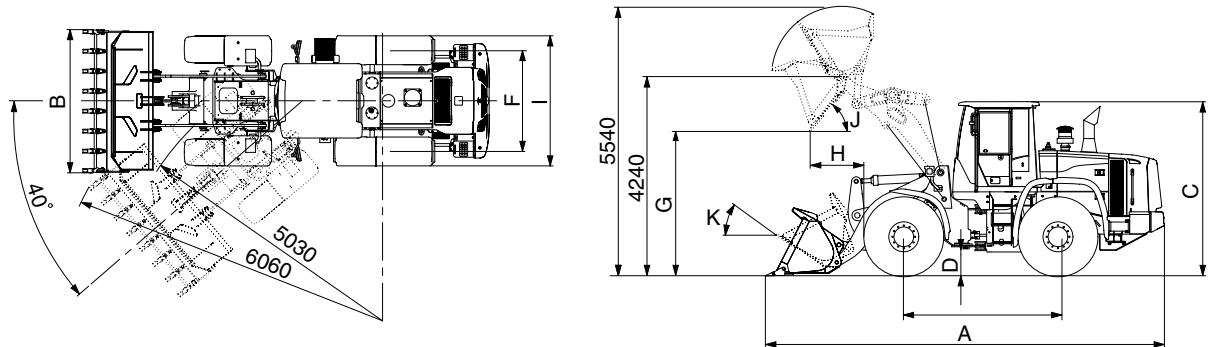

74092SP04

Description		Unit	Specification	
Operating weight		kg (lb)	12300 (27100)	
Bucket capacity	Struck	m <sup>3</sup> (yd <sup>3</sup> )	1.9 (2.5)	
	Heaped		2.2 (2.9)	
Overall length	A	mm (ft-in)	7950 (26' 1")	
Overall width	B		2650 (8' 8")	
Overall height	C		3260 (10' 8")	
Ground clearance	D		417 (1' 4")	
Wheelbase	E		2900 (9' 6")	
Tread	F		1900 (6' 3")	
Dump clearance at 45°	G		3120 (10' 3")	
Dump reach (full lift)	H		1100 (3' 7")	
Width over tires	I		2430 (8' 0")	
Dump angle	J		degree (°)	47
Roll back angle (carry position)	K			49
Cycle time	Lift (with load)	sec	5.5	
	Dump (with load)		1.1	
	Lower (empty)		3.0	
Maximum travel speed		km/hr (mph)	39.0 (24.3)	
Braking distance		m (ft-in)	12 (39' 4")	
Minimum turning radius (center of outside tire)			5.03 (16' 6")	
Gradeability		degree (°)	30	
Travel speed	Forward	km/hr (mph)	First gear	6.7 (4.2)
			Second gear	12.2 (7.6)
			Third gear	23.8 (14.8)
			Fourth gear	39.0 (24.3)
	Reverse		First gear	7.1 (4.4)
			Second gear	12.9 (8.0)
Third gear		25.1 (15.6)		

### 3. WEIGHT

Item		kg	lb
Front frame assembly	HL740-9/XTD-9	904	1990
	HL740TM-9	978	2160
Rear frame assembly		1313	2890
Front fender (LH & RH)		31	68
Counterweight	HL740-9	700	1540
	HL740XTD-9/TM-9	900	1980
Cab assembly		700	1540
Engine assembly		485	1070
Transmission assembly		397	875
Drive shaft (front)		18	40
Drive shaft (center)		16	35
Drive shaft (rear)		13	29
Drive shaft (upper)		7	15
Front axle (include differential)		575	1270
Rear axle (include differential)		560	1240
Tire (20.5-25, 16PR, L3)		203	448
Hydraulic tank assembly		212	467
Fuel tank assembly		290	639
Main pump assembly		28	62
Fan & brake pump assembly		7	15
Main control valve (2/3 spool)		34/41	75/90
Boom assembly	HL740-9	725	1600
	HL740XTD-9	815	1800
	HL740TM-9	670	1480
Bell crank assembly		230	510
Bucket link		37	80
2.3 m <sup>3</sup> bucket, with bolt on cutting edge		1055	2330
2.2 m <sup>3</sup> bucket, with tooth		1000	2200
Boom cylinder assembly	HL740-9/XTD-9	90	198
	HL740TM-9	97	214
Bucket cylinder assembly	HL740-9/XTD-9	111	245
	HL740TM-9	47	100
Steering cylinder assembly		19	42
Seat		40	88
Battery		28	62

#### 4. SPECIFICATION FOR MAJOR COMPONENTS

##### 1) ENGINE

Item	Specification
Model	Cummins QSB6.7
Type	4-cycle turbocharged and charge air-cooled diesel engine.
Cooling method	Water cooling
Number of cylinders and arrangement	6 cylinders, in-line
Firing order	1-5-3-6-2-4
Combustion chamber type	Direct injection type
Cylinder bore × stroke	107 × 124 mm (4.2" × 4.9")
Piston displacement	6730 cc (409 cu in)
Compression ratio	17.2 : 1
Rated gross horse power	145 hp at 2100 rpm
Maximum gross torque at 1400rpm	69 kgf · m (499 lbf · ft)
Engine oil quantity	18 l (4.8 U.S. gal)
Dry weight	485 kg (1069 lb)
High idling speed	2230 ± 50rpm
Low idling speed	950 ± 25 rpm
Rated fuel consumption (at rated)	254 g/kw · hr
Starting motor	Nippondenso 228000-7902 (24 V-3.7 kW)
Alternator	Delco Remy 24SI (24V-70Amp)
Battery	2 × 12V × 80Ah

## 2) MAIN PUMP

Item	Specification
Type	Variable piston pump
Capacity	74 cc/rev
Maximum operating pressure	280 kgf/cm <sup>2</sup> (3980 psi)
Rated operating speed	2100 rpm
Rated output flow	155 l /min (40.9 U.S.gpm)

## 3) FAN AND BRAKE PUMP

Item	Specification	
	Fan	Brake
Type	Fixed displacement tandem helical gear pump	
Capacity	9.1 cc/rev	9.1 cc/rev
Maximum operating pressure	150 kgf/cm <sup>2</sup> (2130 psi)	
Rated operating speed	2100 rpm	
Rated output flow	19 l /min (5.0 U.S.gpm)	19 l /min (5.0 U.S.gpm)

## 4) MAIN CONTROL VALVE

Item	Specification
Type	2 spool (sectional block)
Operating method	Hydraulic pilot assist
Main relief valve set pressure	280 kgf/cm <sup>2</sup> (3980 psi)
Overload relief valve set pressure	340 kgf/cm <sup>2</sup> (4840 psi) / *300 kgf/cm <sup>2</sup> (4270 psi)

\* : Bucket dump

## 5) REMOTE CONTROL VALVE

Item	Specification	
Type	Joystick (or with aux lever)	
Control pressure	Minimum	3.7 kgf/cm <sup>2</sup> (52.6 psi)
	Maximum	30 kgf/cm <sup>2</sup> (427 psi)

## 6) CYLINDER

Item	Specification
Boom cylinder	Bore dia × Rod dia × Stroke ø 110 × ø 65 × 738 mm
Bucket cylinder	Bore dia × Rod dia × Stroke ø 125 × ø 70 × 505 mm
*Bucket cylinder	Bore dia × Rod dia × Stroke ø 95 × ø 50 × 745 mm
Steering cylinder	Bore dia × Rod dia × Stroke ø 65 × ø 40 × 429 mm

\* : HL740TM-9

## 7) DYNAMIC POWER TRANSMISSION DEVICES

Item		Specification
Torque converter	Model	ZF 4WG160
	Type	Single-stage, single-phase
	Ratio	2.348 : 1
Transmission	Type	Full-automatic power shift
	Gear shift	Forward fourth gear, reverse third gear
	Control	Electrical single lever type, kick-down system
	Pump rated flow	85 ℓ /min (22.5 U.S.gpm) at 2000 rpm
Axle	Drive devices	4-wheel drive
	Front	Front fixed location
	Rear	Oscillation $\pm 12^\circ$ of center pin-loaded
Wheels	Tires	20.5-25, 16PR (L3)
Brakes	Travel	Four-wheel, wet-disc type, full hydraulic
	Parking	Spring applied, hydraulic released brake on front axle
Steering	Type	Full hydraulic, articulated
	Steering angle	40° to both right and left angle, respectively

## 5. TIGHTENING TORQUE OF MAJOR COMPONENT

No.	Descriptions	Bolt size	Torque		
			kgf · m	lbf · ft	
1	Engine	Engine mounting bolt, nut (rubber, 2EA)	M16×2.0	29.7 ± 4.5	215 ± 32.5
2		Engine mounting bolt (bracket, 8EA)	M12×1.75	10.7 ± 1.6	77.4 ± 11.6
3		Radiator mounting bolt	M16×2.0	29.7 ± 4.5	215 ± 32.5
4		Fuel tank mounting bolt, nut	M16×2.0	29.7 ± 4.5	215 ± 32.5
5		Air cleaner mounting bolt	M10×1.5	6.9 ± 1.4	50 ± 10.1
6		Muffler mounting nut	M12×1.75	10.7 ± 1.6	77.4 ± 11.6
7	Hydraulic system	Main pump housing mounting bolt	M16×2.0	29.7 ± 4.5	215 ± 32.5
8		Fan & brake pump housing mounting bolt	M10×1.5	6.9 ± 1.4	50 ± 10.1
9		Main control valve mounting bolt	M10×1.5	6.9 ± 1.4	50 ± 10.1
10		Steering unit mounting bolt	M10×1.5	6.9 ± 1.4	50 ± 10.1
11		Stop valve	M10×1.5	6.9 ± 1.4	50 ± 10.1
12		Cushion valve	M8×1.25	2.5 ± 0.5	18.1 ± 3.6
13		Brake valve mounting bolt	M8×1.25	2.5 ± 0.5	18.1 ± 3.6
14		Cut-off valve mounting bolt	M12×1.75	12.8 ± 3.0	92.6 ± 21.7
15		Remote control lever mounting bolt	M6×1.0	1.1 ± 0.2	8.0 ± 1.4
16		Safety valve	M10×1.5	6.9 ± 1.4	50 ± 10.1
17		Hydraulic oil tank mounting bolt	M16×2.0	29.7 ± 4.5	215 ± 32.5
18	Power train system	Transmission mounting bolt, nut (rubber, 4EA)	M20×2.5	57.9 ± 8.7	419 ± 63
19		Transmission mounting bolt (bracket)	M16×2.0	18.4 ± 2.0	133 ± 14.5
20		Front axle mounting bolt, nut	M24×2.0	100 ± 15	723 ± 108
21		Rear axle support mounting bolt, nut	M24×2.0	100 ± 15	723 ± 108
22		Tire mounting nut	M22×1.5	79 ± 2.5	571 ± 18.1
23		Drive shaft joint mounting bolt, nut	3/8-24UNF	6.0 ± 0.8	43.4 ± 5.8
24	Others	Counterweight mounting bolt	M30×3.5	199 ± 30	1439 ± 216
25		Operator's seat mounting bolt	M8×1.25	3.4 ± 0.8	24.6 ± 5
26		ROPS Cab mounting bolt (4EA)	M20×2.5	58 ± 8.7	419 ± 63

## 6. TORQUE CHART

Use following table for unspecified torque.

### 1) BOLT AND NUT

#### (1) Coarse thread

Bolt size	8T		10T	
	kg · m	lb · ft	kg · m	lb · ft
M 6 × 1.0	0.85 ~ 1.25	6.15 ~ 9.04	1.14 ~ 1.74	8.2 ~ 12.6
M 8 × 1.25	2.0 ~ 3.0	14.5 ~ 21.7	2.73 ~ 4.12	19.5 ~ 29.8
M10 × 1.5	4.0 ~ 6.0	28.9 ~ 43.4	5.5 ~ 8.3	39.8 ~ 60
M12 × 1.75	7.4 ~ 11.2	53.5 ~ 79.5	9.8 ~ 15.8	71 ~ 114
M14 × 2.0	12.2 ~ 16.6	88.2 ~ 120	16.7 ~ 22.5	121 ~ 167
M16 × 2.0	18.6 ~ 25.2	135 ~ 182	25.2 ~ 34.2	182 ~ 247
M18 × 2.5	25.8 ~ 35.0	187 ~ 253	35.1 ~ 47.5	254 ~ 343
M20 × 2.5	36.2 ~ 49.0	262 ~ 354	49.2 ~ 66.6	356 ~ 482
M22 × 2.5	48.3 ~ 63.3	350 ~ 457	65.8 ~ 98.0	476 ~ 709
M24 × 3.0	62.5 ~ 84.5	452 ~ 611	85.0 ~ 115	615 ~ 832
M30 × 3.0	124 ~ 168	898 ~ 1214	169 ~ 229	1223 ~ 1655
M36 × 4.0	174 ~ 236	1261 ~ 1703	250 ~ 310	1808 ~ 2242

#### (2) Fine thread

Bolt size	8T		10T	
	kg · m	lb · ft	kg · m	lb · ft
M 8 × 1.0	2.17 ~ 3.37	15.7 ~ 24.3	3.04 ~ 4.44	22.0 ~ 32.0
M10 × 1.25	4.46 ~ 6.66	32.3 ~ 48.2	5.93 ~ 8.93	42.9 ~ 64.6
M12 × 1.25	7.78 ~ 11.58	76.3 ~ 83.7	10.6 ~ 16.0	76.6 ~ 115
M14 × 1.5	13.3 ~ 18.1	96.2 ~ 130	17.9 ~ 24.1	130 ~ 174
M16 × 1.5	19.9 ~ 26.9	144 ~ 194	26.6 ~ 36.0	193 ~ 260
M18 × 1.5	28.6 ~ 43.6	207 ~ 315	38.4 ~ 52.0	278 ~ 376
M20 × 1.5	40.0 ~ 54.0	289 ~ 390	53.4 ~ 72.2	386 ~ 522
M22 × 1.5	52.7 ~ 71.3	381 ~ 515	70.7 ~ 95.7	512 ~ 692
M24 × 2.0	67.9 ~ 91.9	491 ~ 664	90.9 ~ 123	658 ~ 890
M30 × 2.0	137 ~ 185	990 ~ 1338	182 ~ 248	1314 ~ 1795
M36 × 3.0	192 ~ 260	1389 ~ 1879	262 ~ 354	1893 ~ 2561

**2) PIPE AND HOSE (FLARE type)**

Thread size	Width across flat (mm)	kgf · m	lbf · ft
1/4"	19	4	28.9
3/8"	22	5	36.2
1/2"	27	9.5	68.7
3/4"	36	18	130
1"	41	21	152
1-1/4"	50	35	253

**3) PIPE AND HOSE (ORFS type)**

Thread size	Width across flat (mm)	kgf · m	lbf · ft
9/16-18	19	4	28.9
11/16-16	22	5	36.2
13/16-16	27	9.5	68.7
1-3/16-12	36	18	130
1-7/16-12	41	21	152
1-11/16-12	50	35	253

**4) FITTING**

Thread size	Width across flat (mm)	kgf · m	lbf · ft
1/4"	19	4	28.9
3/8"	22	5	36.2
1/2"	27	9.5	68.7
3/4"	36	18	130
1"	41	21	152
1-1/4"	50	35	253

## 7. RECOMMENDED LUBRICANTS

Use only oils listed below or equivalent.

Do not mix different brand oil.

Service point	Kind of fluid	Capacity l (U.S. gal)	Ambient temperature °C ( °F)						
			-20 (-4)	-10 (14)	0 (32)	10 (50)	20 (68)	30 (86)	40 (104)
Engine oil pan	Engine oil	18 (4.8)	SAE 30						
			SAE 10W						
			SAE 10W-30						
			SAE 15W-40						
Transmission	Engine oil	25 (6.6)	SAE 10W-30						
			SAE 15W-40						
Axle	Gear oil	Front : 21.8 (5.8) Rear : 21.8 (5.8)	SAE80W-90LS/API GL-5						
Hydraulic tank	Hydraulic oil	Tank: 151 (39.8) System: 184 (48.6)	ISO VG 32						
			ISO VG 46						
			ISO VG 68						
Fuel tank	Diesel fuel	220 (58.1)	ASTM D975 NO.1						
			ASTM D975 NO.2						
Fitting (grease nipple)	Grease	As required	NLGI NO.1						
			NLGI NO.2						
Radiator	Mixture of antifreeze and water 50 : 50	34 (9.0)	Ethylene glycol base permanent type						

· SAE : Society of Automotive Engineers

· API : American Petroleum Institute

· ISO : International Organization for Standardization

· NLGI : National Lubricating Grease Institute

· ASTM : American Society of Testing and Material