

SECTION 3 POWER TRAIN SYSTEM

Group 1 Structure and Function	3-1
Group 2 Operational Checks and Troubleshooting	3-64
Group 3 Tests and Adjustments	3-75
Group 4 Disassembly and Assembly	3-78

SECTION 3 POWER TRAIN SYSTEM

GROUP 1 STRUCTURE AND FUNCTION

1. POWER TRAIN COMPONENT OVERVIEW

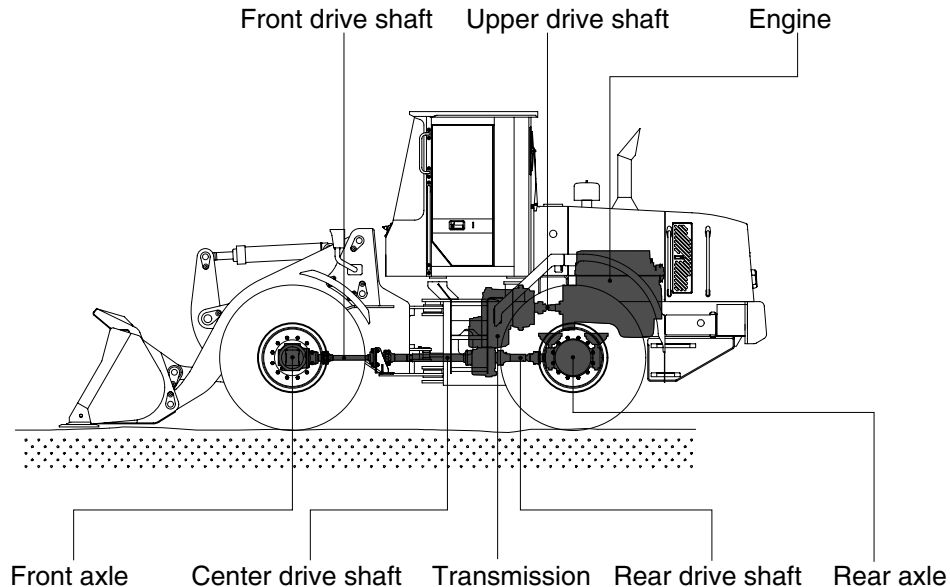

7407APT01

The power train consists of the following components :

- Transmission
- Front, upper, center and rear drive shafts
- Front and rear axles

Engine power is transmitted to the transmission through the torque converter.

The transmission is a hydraulically engaged four speed forward, three speed reverse counter shaft type power shift transmission. A disk type parking brake is located in the front axle.

The transmission outputs through universal joints to three drive shaft assemblies. The front drive shaft is a telescoping shaft which drives the front axle. The front axle is mounted directly to the loader front frame. The front axle is equipped with limited slip differential.

The rear axle is mounted on an oscillating pivot. The rear axle is equipped with conventional differential.

The power transmitted to front axle and rear axle is reduced by the pinion gear and ring gear of differential. It then passes from the differential to the sun gear shaft(Axle shaft) of final drive.

The power of the sun gear is reduced by a planetary mechanism and is transmitted through the planetary hub to the wheel.

HYDRAULIC CIRCUIT

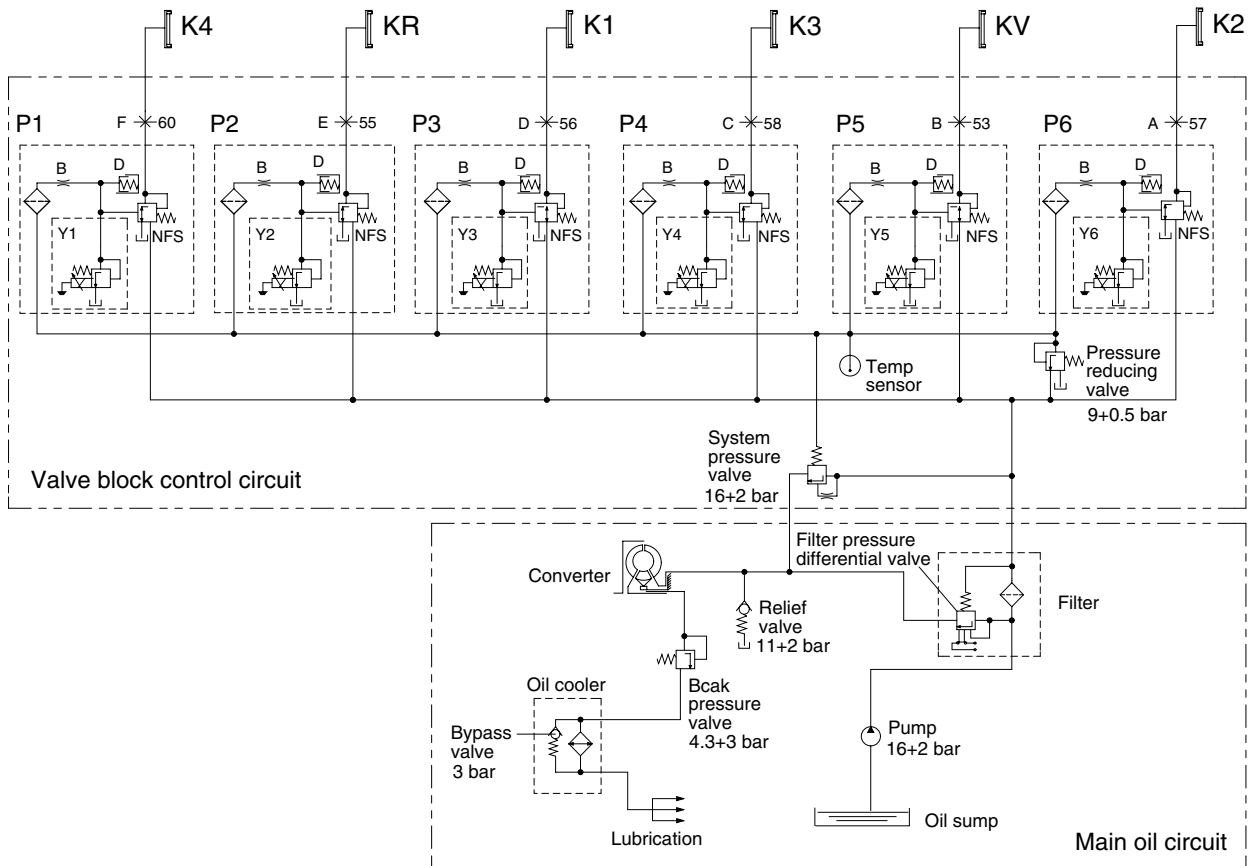

7607APT18

NFS Follow-on slide
 D Vibration damper
 B Orifice
 P1 Proportional valve K4
 P2 Proportional valve KR

P3 Proportional valve K1
 P4 Proportional valve K3
 P5 Proportional valve KV
 P6 Proportional valve K2
 Y1~Y6 Pressure regulator

Speed	Forward				Reverse			Neutral	Engaged clutch	Positions on the valve block	Current No. of the measuring points
	1	2	3	4	1	2	3				
Y1				X					K4	F	60
Y2					X	X	X		KR	E	55
Y3	X				X				K1	D	56
Y4			X	X			X		K3	C	58
Y5	X	X	X						KV	B	53
Y6		X				X			K2	A	57
Engaged clutch	K1,KV	KV,K2	K3,KV	K4,K3	KR,K1	KR,K2	KR, K3		-	-	-

X : Pressure regulator under voltage

2. TORQUE CONVERTER

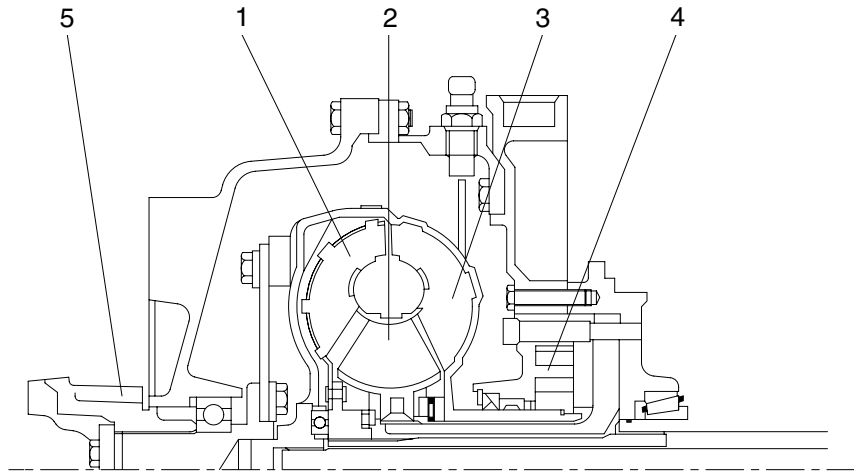

73033TM00

- | | | | | | |
|---|--------|---|-------------------|---|--------------|
| 1 | Pump | 3 | Turbine | 5 | Input flange |
| 2 | Stator | 4 | Transmission pump | | |

The converter is working according to the Trilok-system, i.e. it assumes at high turbine speed the characteristics, and with it the favorable efficiency of a fluid clutch.

The converter is designed according to the engine power so that the most favorable operating conditions are obtained for each installation case.

The Torque converter is composed of 3 main components :
Pump wheel - turbine wheel - stator(Reaction member)

These 3 impeller wheels are arranged in such a ring-shape system that the fluid is streaming through the circuit components in the indicated order.

Pressure oil from the transmission pump is constantly streaming through the converter. In this way, the converter can fulfill its task to multiply the torque of the engine and at the same time, the heat created in the converter is dissipated via the escaping oil.

The oil which is streaming out of the pump wheel, enters the turbine wheel and is there inversed in the direction of flow.

According to the rate of reversion, the turbine wheel and with it also the output shaft is receiving a more or less high reaction torque. The stator(Reaction member), following the turbine, has the task to reverse the oil streaming out of the turbine once more and to deliver it under the suitable discharge direction to the pump wheel.

Due to the reversion, the stator receiving a reaction torque.

The relation turbine torque/pump torque is called torque multiplication. This is the higher, the greater the speed difference of pump wheel and turbine wheel will be.

Therefore, the maximum torque multiplication is created at stationary turbine wheel.

With increasing output speed, the torque multiplication is decreasing. The adaption of the output speed to a certain required output torque will be infinitely variable and automatically achieved by the torque converter.

when the turbine speed is reaching about 80% of the pump speed, the torque multiplication becomes 1.0 i.e. the turbine torque becomes equal to that of the pump torque.
 From this point on, the converter is working similar to a fluid clutch.

A stator freewheel serves to improve the efficiency in the upper driving range, in the torque multiplication range it is backing-up the torque upon the housing, and is released in the clutch range.
 In this way, the stator can rotate freely.

Function of a hydrodynamic torque converter(Schematic view)

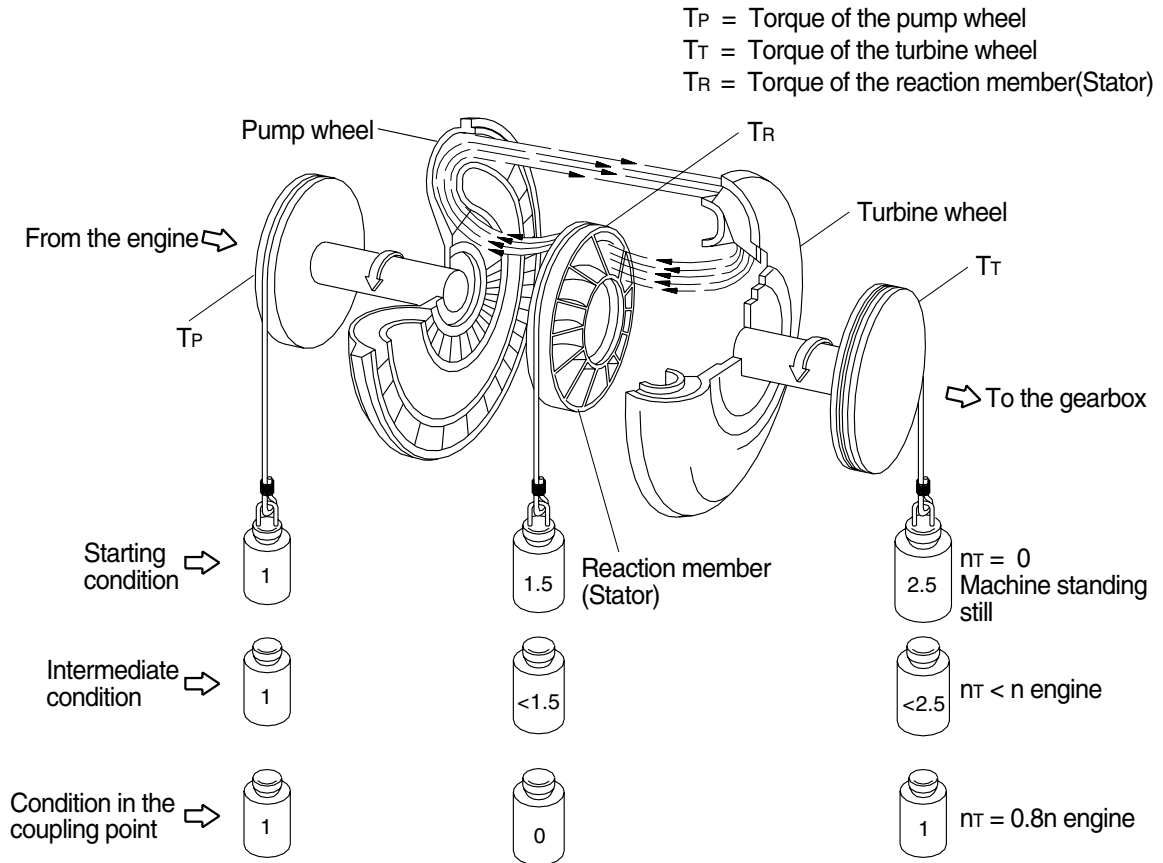

7577APT100

3. TRANSMISSION

1) LAYOUT

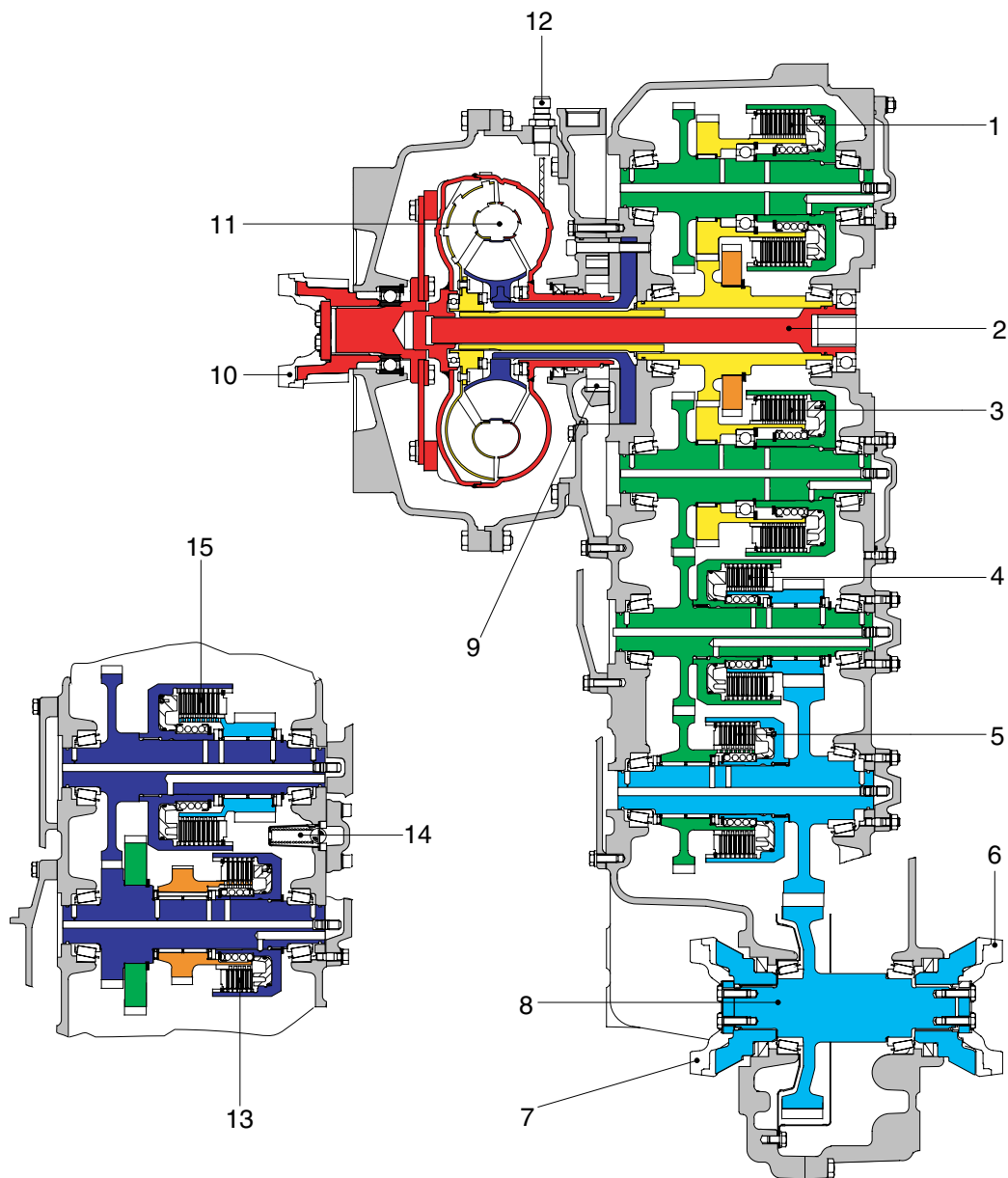

7407APT03

- | | | | | | |
|---|---------------------------------|----|------------------------------|----|--|
| 1 | Reverse clutch(KR) | 6 | Rear output flange | 11 | Converter |
| 2 | Engine-dependent power take-off | 7 | Converter side output flange | 12 | Inductive transmitter for engine speed |
| 3 | Forward clutch(KV) | 8 | Output shaft | 13 | 4th clutch(K4) |
| 4 | 2nd clutch(K2) | 9 | Transmission pump | 14 | Converter relief valve |
| 5 | 3rd clutch(K3) | 10 | Input flange | 15 | 1st clutch(K1) |

2) INSTALLATION VIEW

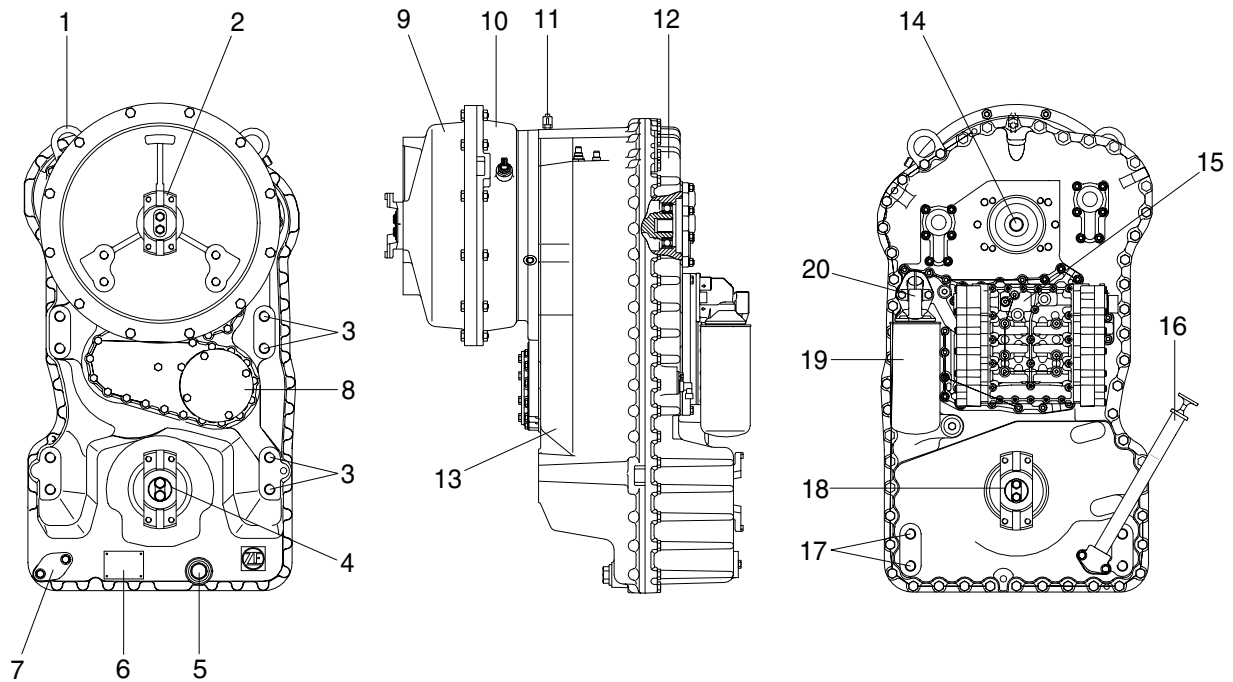

7407PT02

- | | | | |
|----|--|----|--|
| 1 | Lifting lugs | 11 | Breather |
| 2 | Input flange-input through universal shaft | 12 | Transmission-case cover |
| 3 | Transmission suspension threads M20 | 13 | Transmission case |
| 4 | Output flange-converter side | 14 | Power take-off; Coaxial;
Engine-dependent |
| 5 | Oil drain plug with magnetic insert M38 × 1.5 | 15 | Electro-hydraulic control |
| 6 | Model identification plate | 16 | Oil level tube with oil dipstick |
| 7 | Attachment possibility for oil level tube
with oil dipstick(Converter side) | 17 | Transmission suspension threads M20 |
| 8 | Attachment possibility for emergency
steering pump | 18 | Output flange-rear |
| 9 | Cover | 19 | Exchange filter(Fine filter) |
| 10 | Converter bell housing | 20 | Filter head with connection for filter
restriction switch |

3) OPERATION OF TRANSMISSION

(1) Forward

① Forward 1st

In 1st forward, forward clutch and 1st clutch are engaged.

Forward clutch and 1st clutch are actuated by the hydraulic pressure applied to the clutch piston.

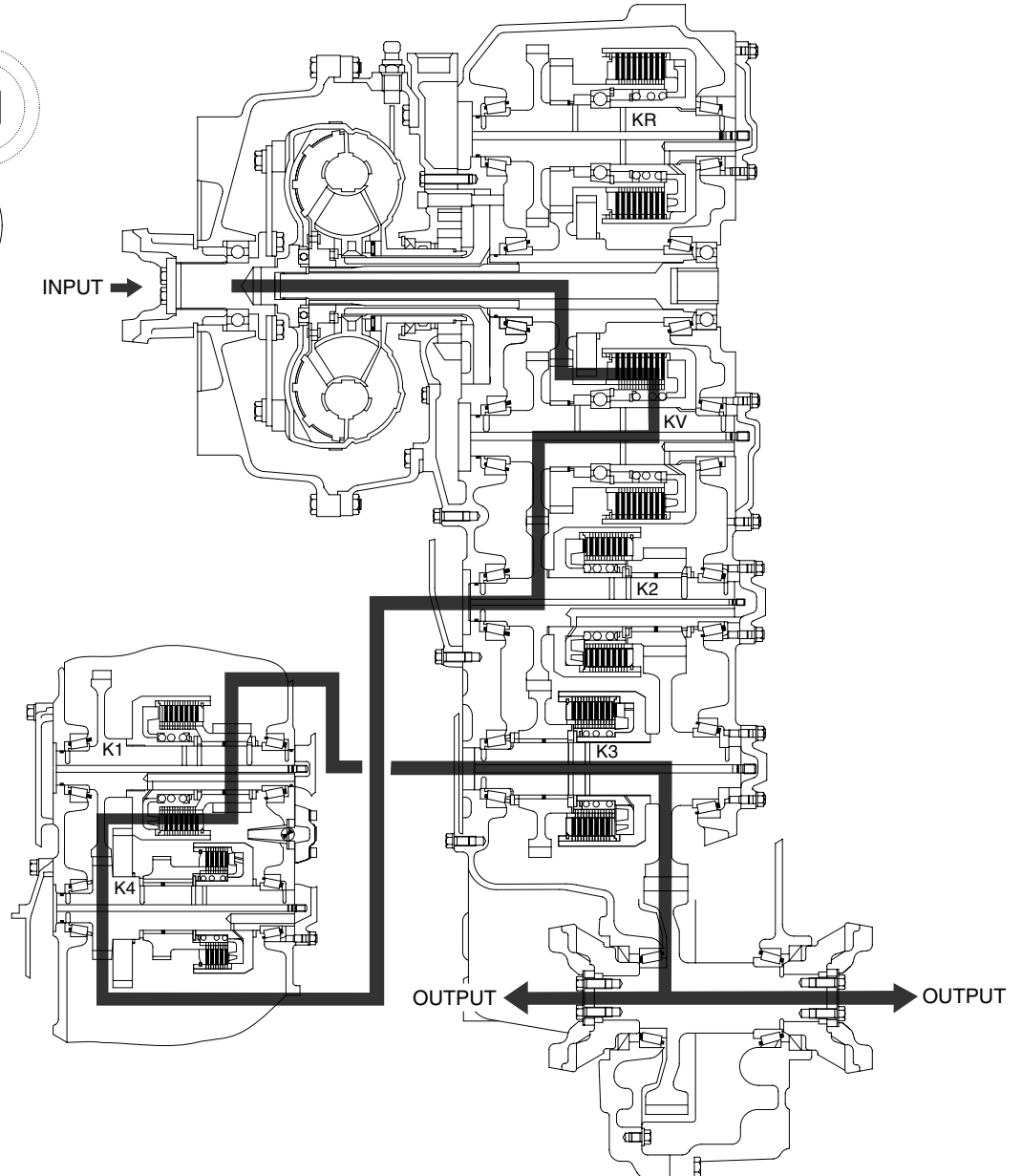
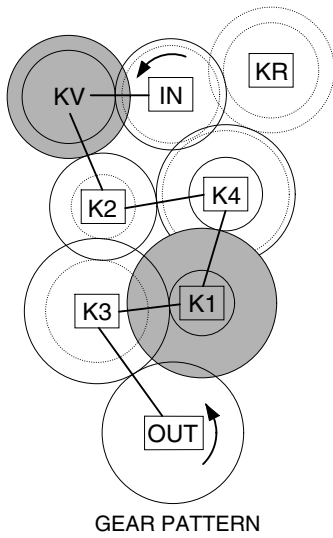

7607PT04

② **Forward 2nd**

In 2nd forward, forward clutch and 2nd clutch are engaged.

Forward clutch and 2nd clutch are actuated by the hydraulic pressure applied to the clutch piston.

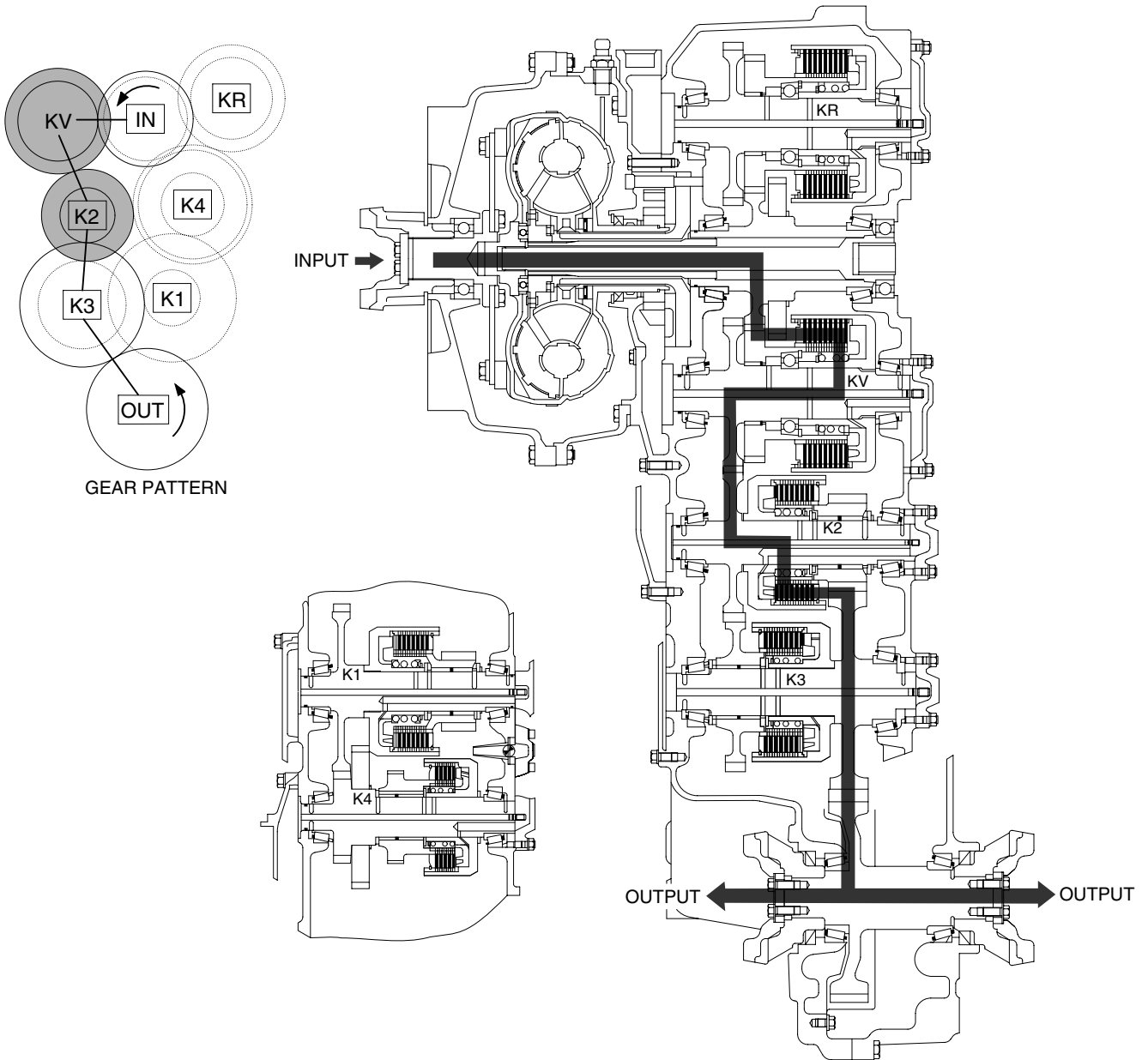

7607PT05

③ Forward 3rd

In 3rd forward, forward clutch and 3rd clutch are engaged.

Forward clutch and 3rd clutch are actuated by the hydraulic pressure applied to the clutch piston.

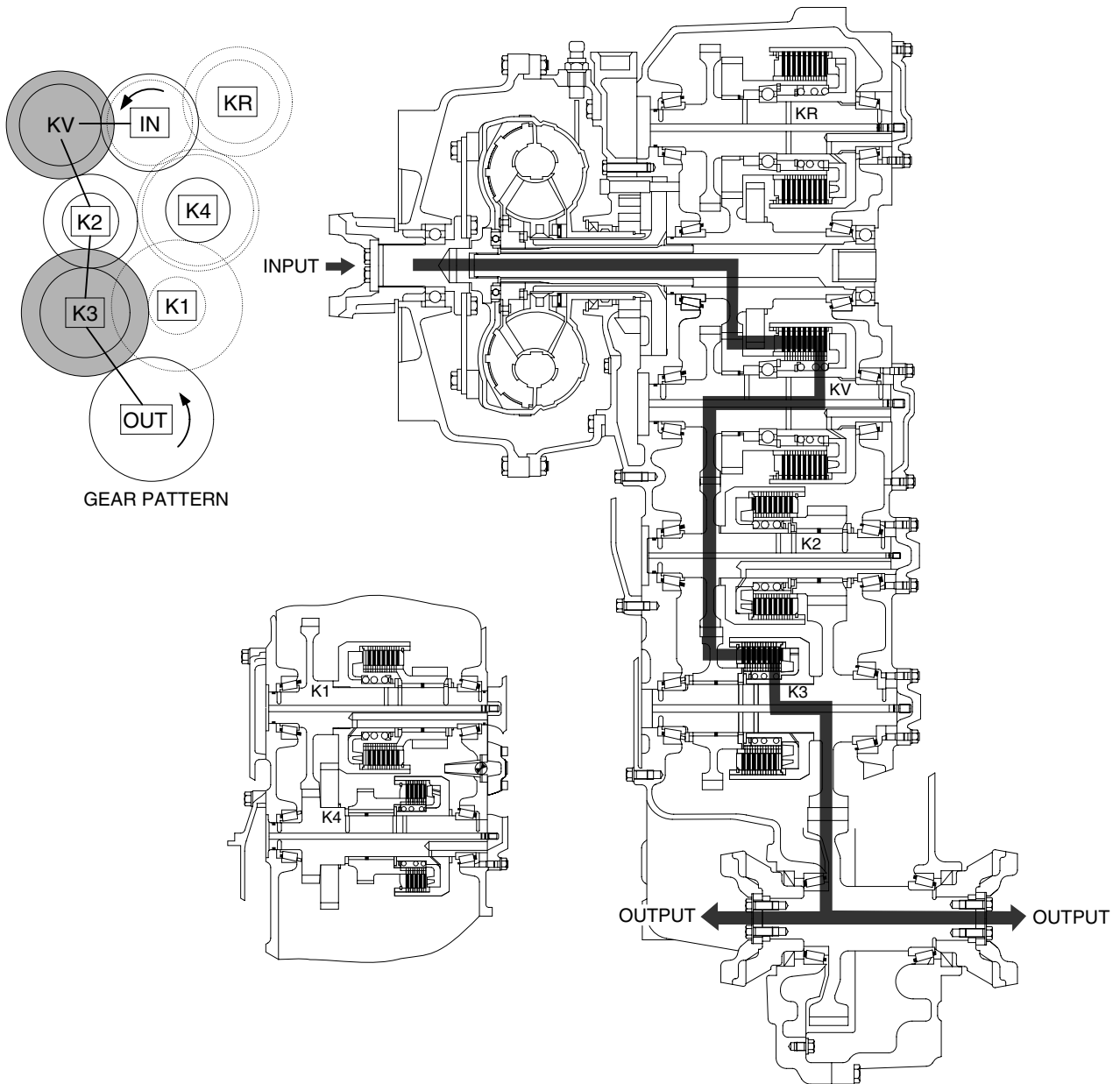

7607PT06

④ **Forward 4th**

In 4th forward, 4th clutch and 3rd clutch are engaged.

4th clutch and 3rd clutch are actuated by the hydraulic pressure applied to the clutch piston.

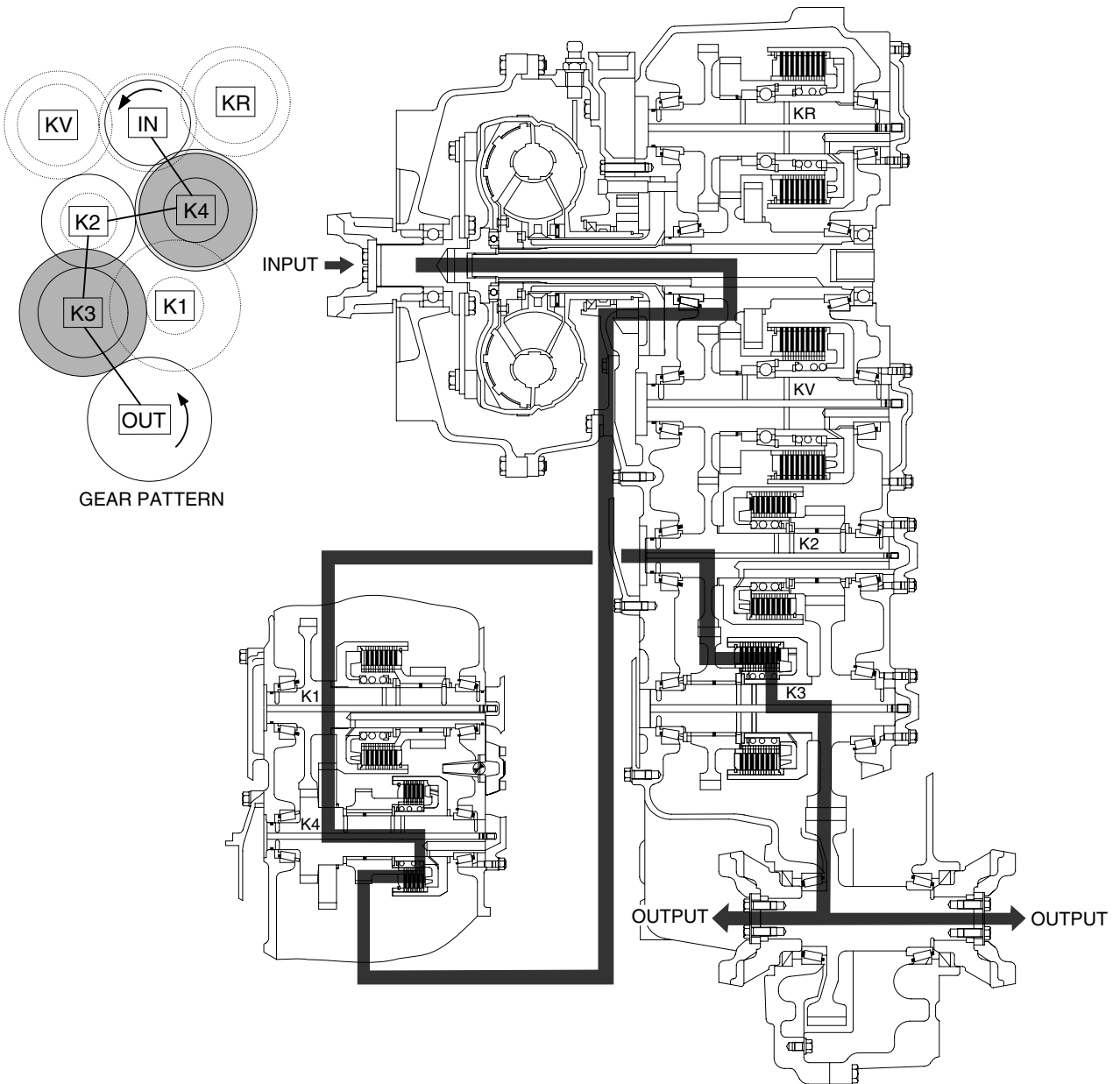

7607PT07

(2) Reverse

① Reverse 1st

In 1st reverse, reverse clutch and 1st clutch are engaged.

Reverse clutch and 1st clutch are actuated by the hydraulic pressure applied to the clutch piston.

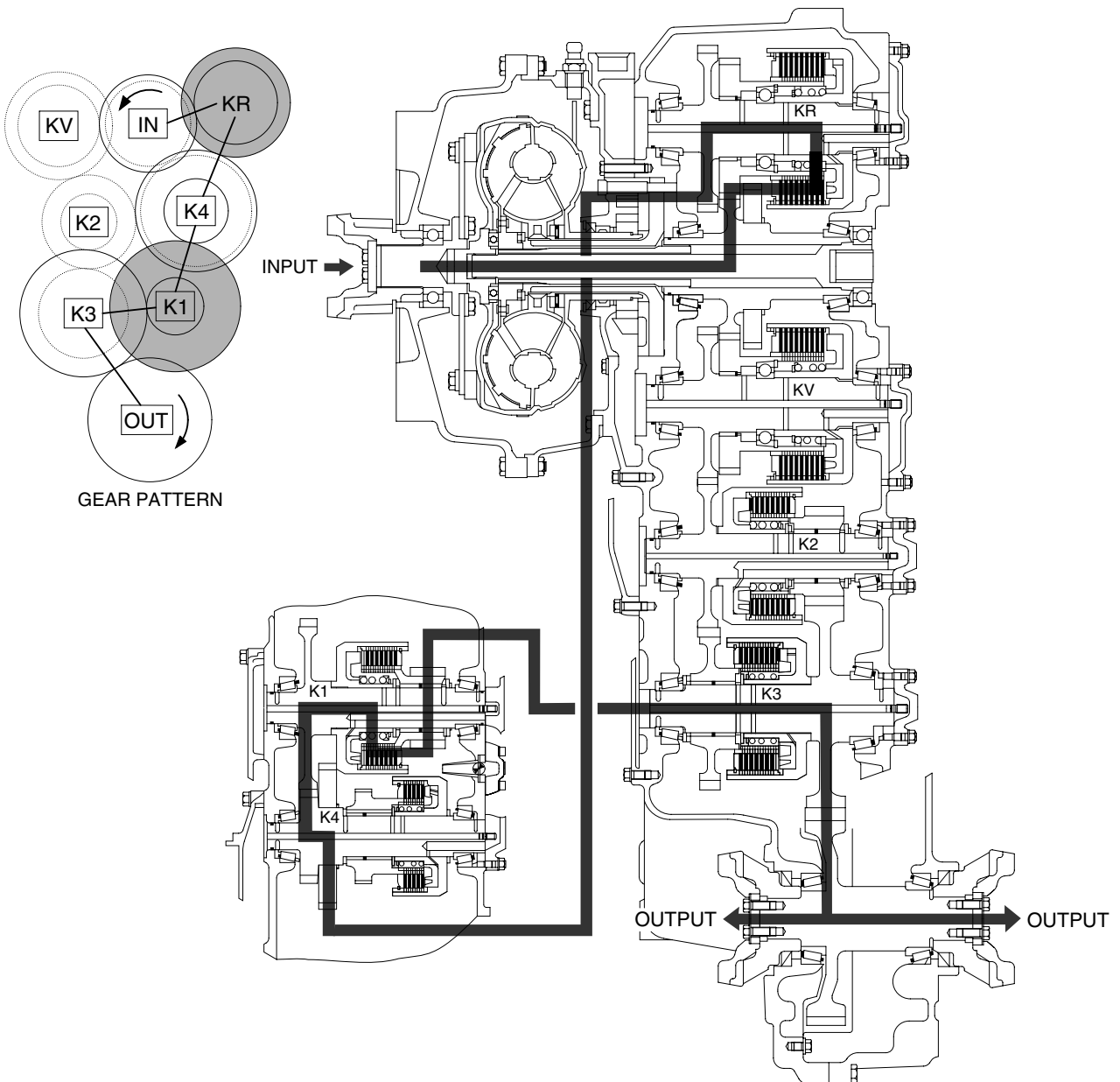

7607PT08

② **Reverse 2nd**

In 2nd reverse, reverse clutch and 2nd clutch are engaged.

Reverse clutch and 2nd clutch are actuated by the hydraulic pressure applied to the clutch piston.

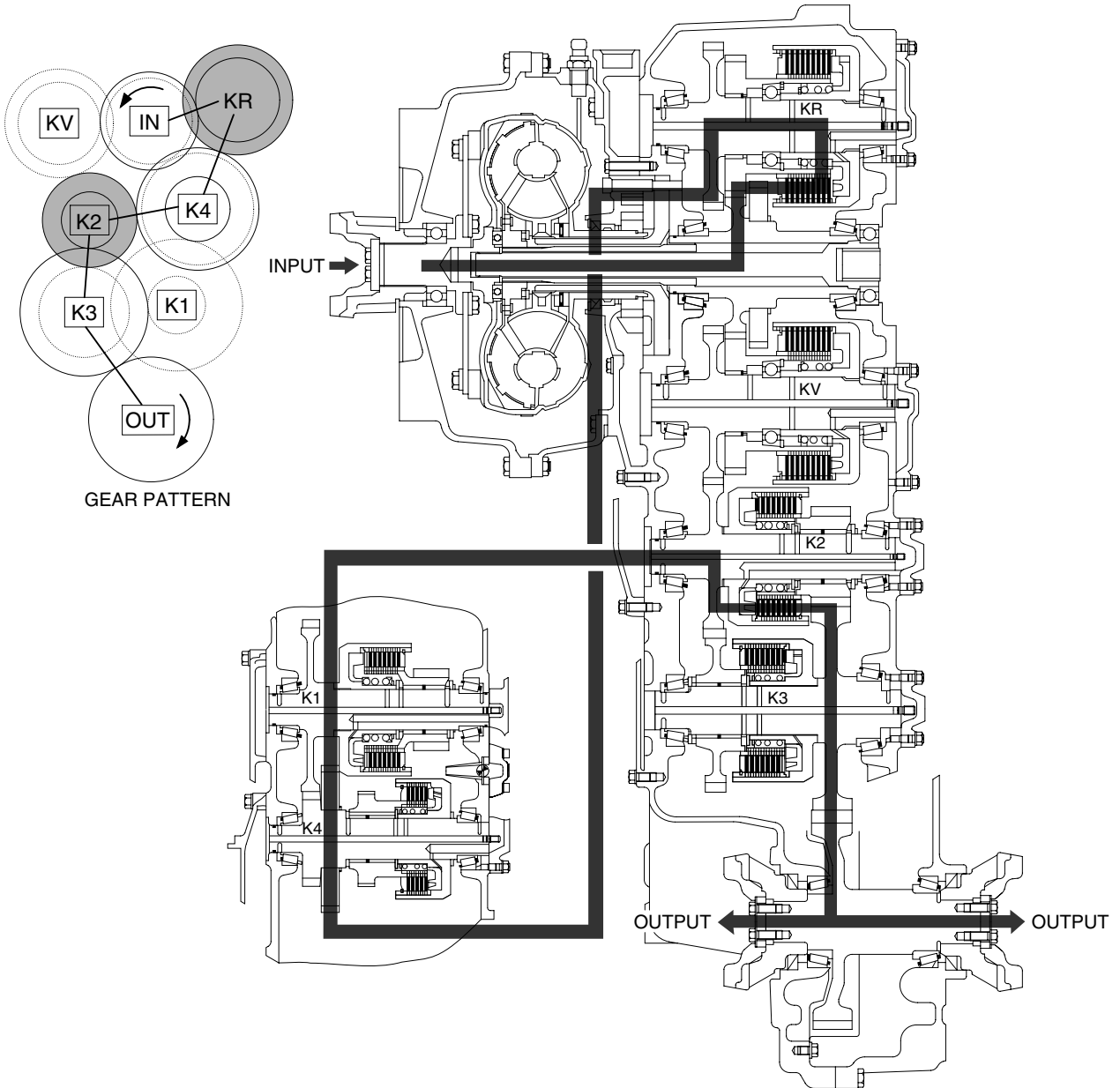

7607PT09

③ Reverse 3rd

In 3rd reverse, reverse clutch and 3rd clutch are engaged.

Reverse clutch and 3rd clutch are actuated by the hydraulic pressure applied to the clutch piston.

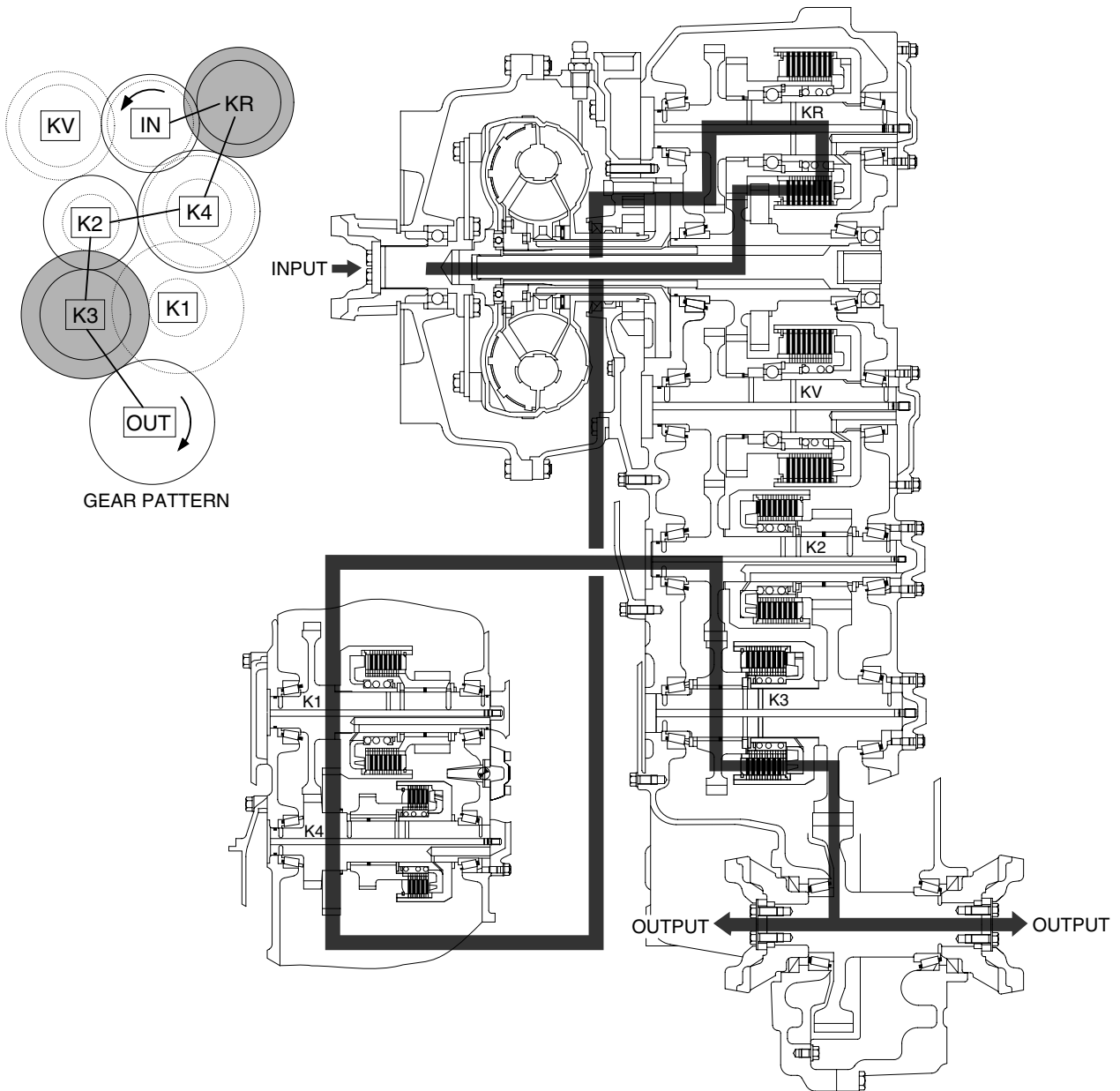

7607PT10

4) ELECTRO-HYDRAULIC SHIFT CONTROL WITH PROPORTIONAL VALVE

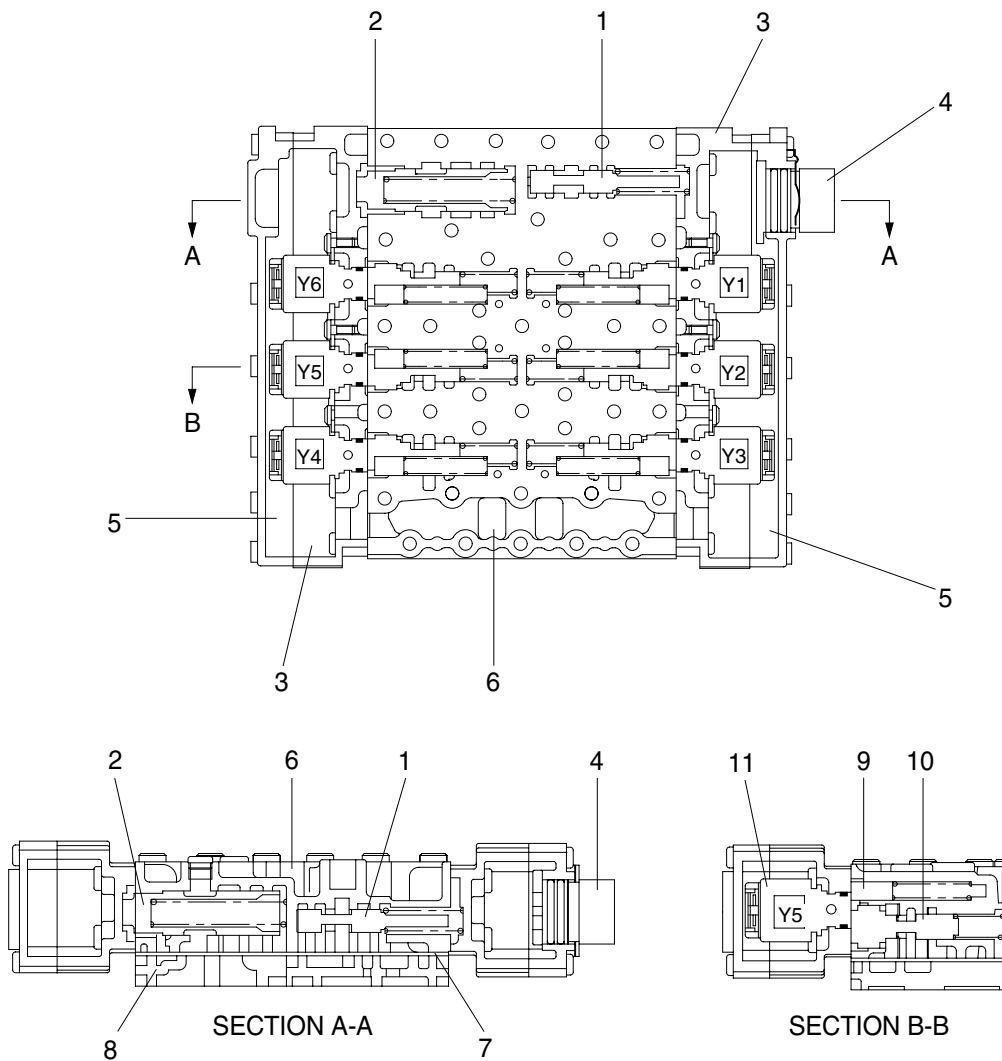

73033CV01

- | | | | |
|---|--------------------------------|----|--------------------|
| 1 | Pressure reducing valve(9bar) | 7 | Intermediate sheet |
| 2 | System pressure valve(16+2bar) | 8 | Duct plate |
| 3 | Housing | 9 | Oscillation damper |
| 4 | Cable harness | 10 | Follow-on slide |
| 5 | Cover | 11 | Pressure regulator |
| 6 | Valve block | | |

Transmission control, see schedule of hydraulic circuit, electro-hydraulic control unit and measuring points at page 3-2, 3-14 and 3-76.

The six clutches of the transmission are selected via the 6 proportional valves P1 to P6. The proportional valve(Pressure regulator unit) is composed of pressure regulator(e.g. Y1), follow-on slide and vibration damper.

The control pressure of 9 bar for the actuation of the follow-on slides is created by the pressure reducing valve. The pressure oil (16+2bar) is directed via the follow-on slide to the respective clutch.

Due to the direct proportional selection with separated pressure modulation for each clutch, the pressures to the clutches, which are engaged in the gear change, will be controlled. In this way, a hydraulic intersection of the clutches to be engaged and disengaged becomes possible.

This is creating spontaneous shiftings without traction force interruption.

At the shifting, the following criteria are considered:

- Speed of engine, turbine, central gear train and output.
- Transmission temperature.
- Shifting mode(Up-, down-, reverse shifting and speed engagement out of neutral).
- Load condition(Full and part load, traction, overrun inclusive consideration of load cycles during the shifting).

The main pressure valve is limiting the maximum control pressure to 16+2 bar and releases the main stream to the converter and lubricating circuit.

In the inlet to the converter, a converter safety valve is installed which protects the converter from high internal pressures(Opening pressure 11bar).

Within the converter, the oil serves to transmit the power according to the well-known hydrodynamic principle(See torque converter, page 3-3).

To avoid cavitation, the converter must be always completely filled with oil.

This is achieved by a converter back pressure back-up valve, rear-mounted to the converter, with an opening pressure of at least 4.3bar.

The oil, escaping out of the converter, is directed to a oil cooler.

The oil is directed from the oil cooler to the transmission and from there to the lubricating oil circuit, so that all lubricating points are supplied with cooled oil.

In the electro-hydraulic control unit are 6 pressure regulators installed.

5) GEAR SELECTOR(DW-3)

The gear selector is designed for the mounting on the left side of the steering column. The positions(Speeds) 1 to 4 are selected by a rotary motion, the driving direction Forward(F)-Neutral(N)-Reverse(R) by tilting the gear selector lever.

The gear selector is also available with integrated kickdown push button.

For the protection from unintended start off, a neutral interlock is installed.

Position **N** - Gear selector lever blocked in this position.

Position **D** - Driving.

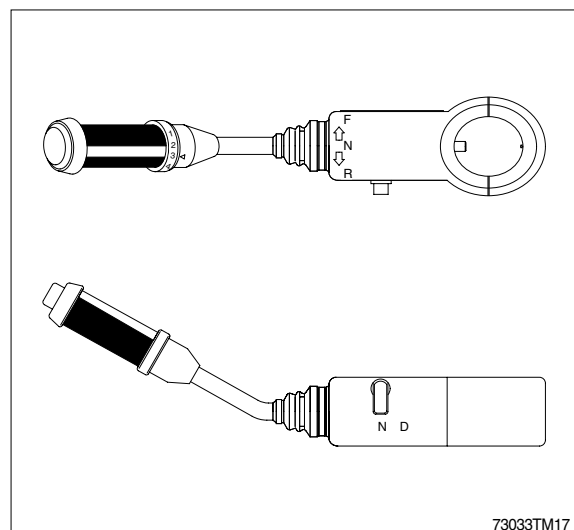

6) LCD

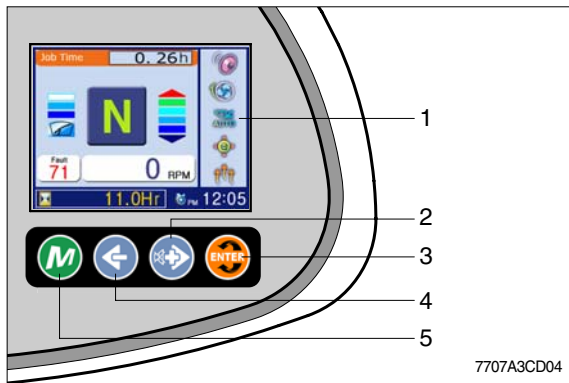

- 1 LCD
- 2 Right, Buzzer stop
Move to the next selection
- 3 Select(Enter)
Activate the currently chosen item
- 4 Escape
Return to the previous menu
- 5 Main, Menu
- Display menu
- Return to the main display

(1) Main display

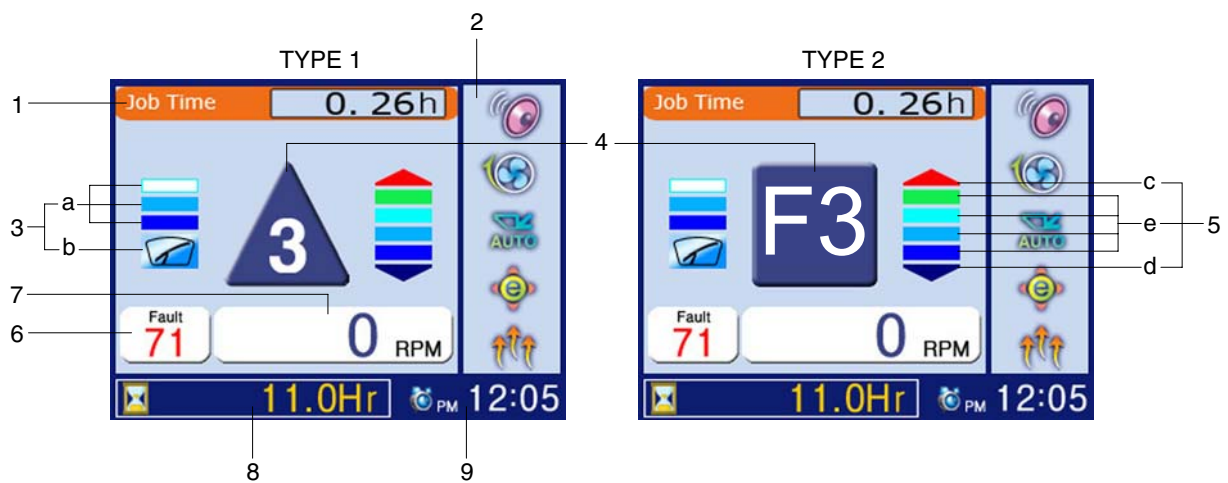

7707A3CD10







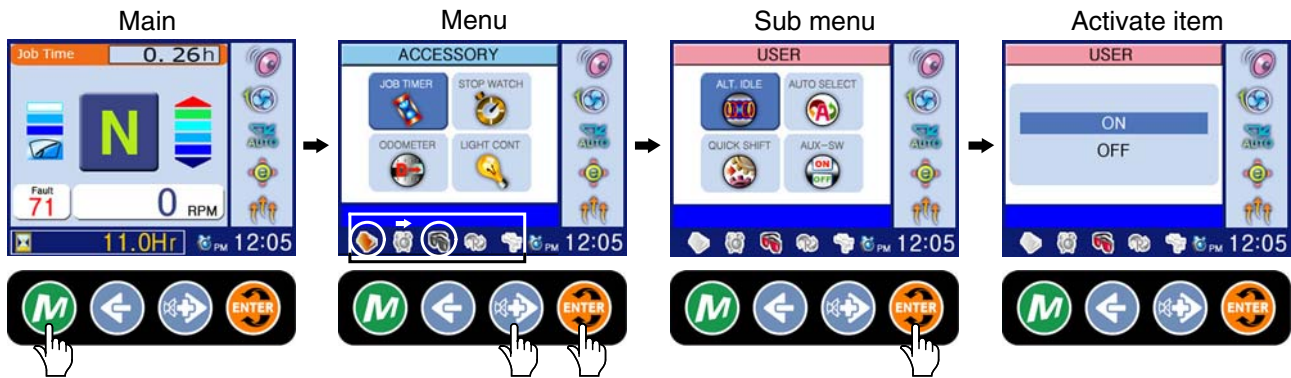



No	Symbol	Meaning	Remark
1		Monitoring information	Job timer, Odometer, Hydraulic temperature, Battery voltage, Coolant temperature, T/M oil temperature.
2		State information	Buzzer, Fan state, Ride state(option), Steering joystic(option), Warming up
3	a b	Wiper display	When operating intermittently, it shows an operating time interval Wiper motor intermittently operating
4		Actual gear display	Forward, reverse, neutral
	F, R, N		Forward, reverse, neutral
	1, 2, 3, 4		Actual gear
	P		Parking brake mode active
5	c, d	Select gear display	Up and down shifting c: Forward, d: Reverse
	e		Pre-selected gear
6		Fault code display	Fault code state display
7		Engine rpm display	Now engine rpm state display
8		Hour meter display	Hour meter state display
9		Timer & alarm display	Now time & alarm state display

※ Both type1 and type2 are LCD modes and they can be changed each other by operator's selection.
(Adjustment/Display, see page 3-18)











(2) Display map



7707A3CD11

Main group	Sub group	Meaning	Display on LCD	
Accessory 	Job timer	<ul style="list-style-type: none"> Measure the various job time. Press ENTER : Display ON, OFF or RESET 	Job Time <input type="text" value="1.26h"/>	
	Stop watch	<ul style="list-style-type: none"> Measures time in seconds. Press ENTER : Start. Press ENTER again : Stop. 	-	
	Odometer	Latest	Distance until recent times.	Latest <input type="text" value="20.5 Km"/>
		Total	Total distance.	Total <input type="text" value="30.5 Km"/>
Light control		<ul style="list-style-type: none"> Control of LCD display luminosity. Brightness control :  	-	
Clock 	Time set	<ul style="list-style-type: none"> When 12H or 24H is selected, the current hour appears.  : input, ENTER : setting. 	PM 22:05	
	Clock ON/OFF	<ul style="list-style-type: none"> ENTER : Clock display ON or OFF. 		
	Alarm	1	<ul style="list-style-type: none"> Alarm setting. It is possible to set 3 alarms. Stop alarming :  	
		2		
3				
User 	Alternate idle	ON	<ul style="list-style-type: none"> Raise the idle rpm to 1200rpm automatically to warm up the engine. 	-
		OFF		
	Auto select	Mode 1 (1st-4th)	Automatic travelling speed is applied from 1st to 4th gear.	-
		Mode 2 (2nd-4th)	Automatic travelling speed is applied from 2nd to 4th gear.	-
	Quick shift	Mode 1 (Down/Up)	Press button once : Shift down, press button again ; shift up.	-
		Mode 2 (Down only)	Press button every time : Shift to lower gear respectively.	-
	Aux-sw	Auto select	<ul style="list-style-type: none"> ON : Transmission auto condition. OFF : Transmission semi-auto condition. 	
		Clutch cut-off	<ul style="list-style-type: none"> ON : Clutch cut-off is activated. OFF : Clutch cut-off is cancelled. 	-
Fan control	Forward	Forward active		
	Reverse	Reverse active*		

★Reverse mode cleans out quickly dirt and dust on radiator and cooler by reverse rotation of cooling fan.

Main group	Sub group		Meaning	Display on LCD
Adjustment 	Unit	MKS	<ul style="list-style-type: none"> Choose between metric and inch unit display. 	Total 50.7 Km
		ENG		Total 31.5 Mile
	Wiper Intermittence		<ul style="list-style-type: none"> When using the intermittent function of wiper motor, it regulates operation time. 	
	Alternate RPM		<ul style="list-style-type: none"> Regulate idle rpm. Press  : Adjust idle rpm increments (or decrement) by 25rpm. 	-
	Pulse		<ul style="list-style-type: none"> Press  : Modification. 	-
	AEB		<ul style="list-style-type: none"> It controls the disk interval of the transmission, automatically. 	ST
	Model		<ul style="list-style-type: none"> It is set at the factory, so there's no need to change. 	-
	ENG/KOR		<ul style="list-style-type: none"> English : Display in English. Korean : Display in Korean. 	-
Display 1/2		<ul style="list-style-type: none"> Type 1 : Indicate with the symbol. Type 2 : Indicate with a letter. 	 , 	
Diagnostics 	Machine	Fault code	<ul style="list-style-type: none"> Error code display. Refer to page 3-19. 	-
		Monitor	<ul style="list-style-type: none"> Hydraulic temperature and battery voltage display. Press  : Display ON or OFF. 	HYD temp 100.6°C Bat Volt 27.5 V
	Engine	Fault code	<ul style="list-style-type: none"> Error code display. Consult a Hyundai dealer to error code. 	-
		Monitor	<ul style="list-style-type: none"> Engine coolant temperature display. Press  : Display ON or OFF. 	Coolant Temp 57.6°C
	Transmission	Fault code	<ul style="list-style-type: none"> Error code display. Consult a Hyundai dealer to error code. 	-
		Monitor	<ul style="list-style-type: none"> Transmission oil temperature display. Press  : Display ON or OFF. 	Oil Temp 37.6°C
Version		<ul style="list-style-type: none"> Display the controller(MCU) and cluster version. 	-	

(3) Machine fault code

When selecting the fault code menu, it shows all of the fault codes which mean abnormal conditions of present time.

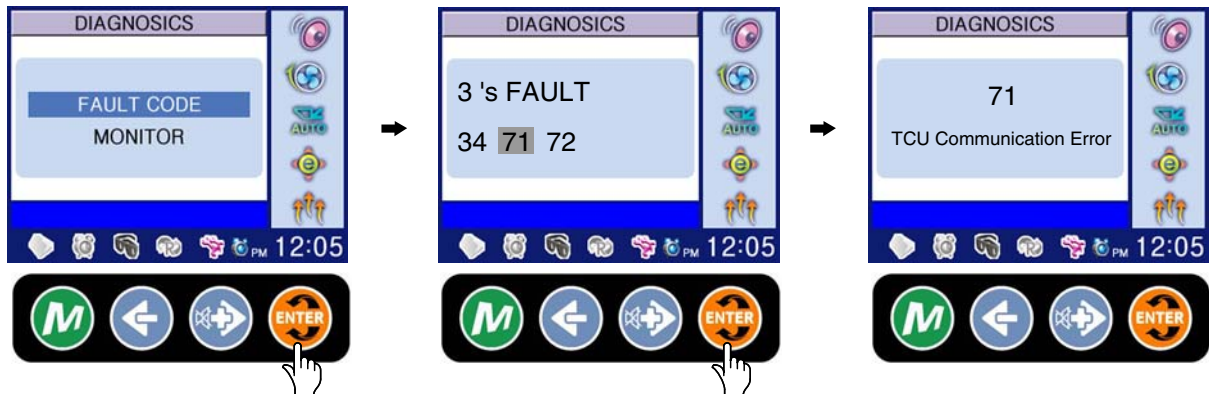

7707A3CD36

※ To go out from fault explanation window, press button.

(Press , to go out to main.)

※ **No error** will be indicated in case that there's no fault.

Description	Code	Meaning	Remark
Electrical system	010	Power input voltage low	Below 18V
	011	Power input voltage high	Above 38V
	012	Alternator voltage low	Below 5V
	013	Alternator voltage high	Above 36V
	014	Buzzer circuit open or short to ground	
	015	Buzzer circuit short to power	
Hydraulic system	020	Hydraulic oil temperature sensor open or short to power	
	021	Hydraulic oil temperature sensor short to ground	
Engine system	030	Fuel level sensor open or short to power	
	031	Fuel level sensor short to ground	
	034	Cooling fan driving valve open or short to ground	
	035	Cooling fan driving valve short to power	
T/M system	050	Auto select switch supply power open or short to power	
	051	Auto select switch supply power short to ground	
	052	Clutch cutoff supply power open or short to power	
	053	Clutch cutoff supply power short to ground	
Steering system	060	Emergency steering relay open or short to ground	Option
	061	Emergency steering relay short to power	Option
Communication	070	MCU communication error	
	071	TCU communication error	
	072	ECM communication error	

MCU : Machine control unit TCU : Transmission control unit ECM : Engine control module

(4) Transmission warning

Symbol	Meaning	Remarks
LF, LR	Limp home gear	-
F/R/△/▽ flashing	Direction F or R selected while turbine speed is too high, CAUTION gear will engage if turbine speed drops	-
	Oil temperature too low, no gear available	Warm up engine / transmission
WS	Warning sump temperature	Changes between actual gear/direction while driving, in neutral only displayed if no fault is detected
WT	Warning torque converter temperature	Changes between actual gear/direction while driving, in neutral only displayed if no fault is detected
WE	Warning high engine speed	Changes between actual gear/direction while driving, in neutral only displayed if no fault is detected

(5) Display during AEB mode

Symbol	Meaning	Remarks
K1~K4, KV, KR	Calibrating clutch K1~K4, KV or KR respectively	
- And Kx	Wait for start, initialization of clutch Kx, x : 1, 2, 3, 4, V, R	
≡ And Kx	Fast fill time determination of clutch Kx	
= And Kx	Compensating pressure determination of clutch Kx	
OK	Calibration for all clutches finished	Transmission stays in neutral, you have to restart the TCU(Ignition off/on)
STOP	AEB canceled(Activation stopped)	Transmission stays in neutral, you have to restart the TCU(Ignition off/on)
STOP and Kx	AEB stopped, clutch Kx can't be calibrated	Transmission stays in neutral, you have to restart the TCU(Ignition off/on)
Spanner and Kx	Kx couldn't be calibrated, AEB finished	Transmission stays in neutral, you have to restart the TCU(Ignition off/on)
△E	Engine speed too low, - Raise engine speed	
▽E	Engine speed too high, - Lower engine speed	
△T	Transmission oil temperature too low, - Heat up transmission	
▽T	Transmission oil temperature too high, - Cool down transmission	
FT	Transmission temperature not in defined range during calibration	Transmission stays in neutral, you have to restart the TCU(Ignition off/on)
FB	Operating mode not NORMAL or transmission temperature sensor defective or storing of calibrated values to EEPROM has failed	Transmission stays in neutral, you have to restart the TCU(Ignition off/on)
FO	Output speed not zero	Transmission stays in neutral, you have to restart the TCU(Ignition off/on)
FN	Shift lever not in neutral position	Transmission stays in neutral, you have to restart the TCU(Ignition off/on)
FP	Park brake not applied	Transmission stays in neutral, you have to restart the TCU(Ignition off/on)

※ **AEB mode** : It controls the disk internal of the transmission, automatically.

(6) Engine fault codes

Fault code No.	Reason	Effect (only when fault code is active)
111	Engine control module critical internal failure - Bad intelligent device or component. Error internal to the ECM related to memory hardware failures or internal ECM voltage supply circuits.	Possible no noticeable performance effects, engine dying, or hard starting.
115	Engine magnetic crankshaft speed/position lost both of two signals - Data erratic, intermittent, or incorrect. The ECM has detected that the primary engine speed sensor and the backup engine speed sensor signals are reversed.	Fueling to injectors is disabled and the engine can not be started.
122	Intake manifold 1 pressure sensor circuit - Voltage above normal, or shorted to high source. High signal voltage detected at the intake manifold pressure circuit.	Engine power derate.
123	Intake manifold 1 pressure sensor circuit - Voltage below normal, or shorted to low Source. Low signal voltage or open circuit detected at the intake manifold pressure circuit.	Engine power derate.
124	Intake manifold 1 pressure - Data valid but above normal operational range - Moderately severe level. Intake manifold pressure has exceeded the maximum limit for the given engine rating.	Engine power derate.
131	Accelerator pedal or lever position sensor 1 circuit - Voltage above normal, or shorted to high source. High voltage detected at accelerator pedal position circuit.	Severe derate in power output of the engine. Limp home power only.
132	Accelerator pedal or lever position sensor 1 circuit - Voltage below normal, or shorted to low source. Low voltage detected at accelerator pedal position signal circuit.	Severe derate in power output of the engine. Limp home power only.
133	Remote accelerator pedal or lever position sensor 1 circuit - Voltage above normal, or shorted to high source. High voltage detected at remote accelerator pedal position circuit.	Remote accelerator will not operate. Remote accelerator position will be set to zero percent.
134	Remote accelerator pedal or lever position sensor 1 circuit - Voltage below normal, or shorted to low source. Low voltage detected at remote accelerator pedal position signal circuit.	Remote accelerator will not operate. Remote accelerator position will be set to zero percent.
135	Engine oil rifle pressure 1 sensor circuit - Voltage above normal, or shorted to high source. High signal voltage detected at the engine oil pressure circuit.	None on performance. No engine protection for oil pressure.
141	Engine oil rifle pressure 1 sensor circuit - Voltage below normal, or shorted to low source. Low signal voltage detected at engine oil pressure circuit.	None on performance. No engine protection for oil pressure.
143	Engine oil rifle pressure - Data valid but below normal operational range - Moderately severe level.	None on performance.
144	Engine coolant temperature 1 sensor circuit - Voltage above normal, or shorted to high source. High signal voltage or open circuit detected at engine coolant temperature circuit.	Possible white smoke. Fan will stay ON if controlled by ECM. No engine protection for engine coolant temperature.

Fault code No.	Reason	Effect (only when fault code is active)
145	Engine Coolant Temperature 1 Sensor Circuit - Voltage Below Normal, or Shorted to Low Source. Low signal voltage detected at engine coolant temperature circuit.	Possible white smoke. Fan will stay ON if controlled by ECM. No engine protection for engine coolant temperature.
146	Engine Coolant Temperature - Data Valid but Above Normal Operational Range - Moderately Severe Level. Engine coolant temperature signal indicates engine coolant temperature is above engine protection warning limit.	Progressive power derate increasing in severity from time of alert.
147	Accelerator Pedal or Lever Position 1 Sensor Circuit Frequency - Data Valid but Below Normal Operational Range - Most Severe Level. A frequency of less than 100 Hz has been detected at the frequency throttle input to the ECM.	Severe derate in power output of the engine. Limp home power only.
148	Accelerator Pedal or Lever Position Sensor 1 - Data Valid but Above Normal Operational Range - Most Severe Level. A frequency of more than 1500 Hz has been detected at the frequency throttle input to the ECM.	Severe derate in power output of the engine. Limp home power only.
151	Engine Coolant Temperature - Data Valid but Above Normal Operational Range - Most Severe Level. Engine coolant temperature signal indicates engine coolant temperature above engine protection critical limit.	Progressive power derate increasing in severity from time of alert. If Engine Protection Shutdown feature is enabled, engine will shut down 30 seconds after Red Stop Lamp starts flashing.
153	Intake Manifold 1 Temperature Sensor Circuit - Voltage Above Normal, or Shorted to High Source. High signal voltage detected at intake manifold air temperature circuit.	Possible white smoke. Fan will stay ON if controlled by ECM. No engine protection for intake manifold air temperature.
154	Intake Manifold 1 Temperature Sensor Circuit - Voltage Below Normal, or Shorted to Low Source. Low signal voltage detected at intake manifold air temperature circuit.	Possible white smoke. Fan will stay ON if controlled by ECM. No engine protection for intake manifold air temperature.
155	Intake Manifold 1 Temperature - Data Valid but Above Normal Operational Range - Most Severe Level. Intake manifold air temperature signal indicates intake manifold air temperature above engine protection critical limit.	Progressive power derate increasing in severity from time of alert. If Engine Protection Shutdown feature is enabled, engine will shut down 30 seconds after Red Stop Lamp starts flashing.
187	Sensor Supply 2 Circuit - Voltage Below Normal, or Shorted to Low Source. Low voltage detected at the sensor supply number 2 circuit.	Engine power derate.
195	Coolant Level Sensor 1 Circuit - Voltage Above Normal, or Shorted to High Source. High signal voltage detected at engine coolant level circuit.	None on performance.
196	Coolant Level Sensor 1 Circuit - Voltage Below Normal, or Shorted to Low Source. Low signal voltage detected at engine coolant level circuit.	None on performance.
197	Coolant Level - Data Valid but Below Normal Operational Range - Moderately Severe Level. Low coolant level has been detected.	None on performance.
221	Barometric Pressure Sensor Circuit - Voltage Above Normal, or Shorted to High Source. High signal voltage detected at barometric pressure circuit.	Engine power derate.

Fault code No.	Reason	Effect (only when fault code is active)
222	Barometric Pressure Sensor Circuit - Voltage Below Normal, or Shorted to Low Source. Low signal voltage detected at barometric pressure circuit.	Engine power derate.
234	Engine Crankshaft Speed/Position - Data Valid but Above Normal Operational Range - Most Severe Level. Engine speed signal indicates engine speed above engine protection limit.	Fuel injection disabled until engine speed falls below the overspeed limit.
235	Coolant Level - Data Valid but Below Normal Operational Range - Most Severe Level. Low engine coolant level detected.	Progressive power derate increasing in severity from time of alert. If Engine Protection Shutdown feature is enabled, engine will shut down 30 seconds after Red Stop Lamp starts flashing.
237	External Speed Command Input (Multiple Unit Synchronization) - Data Erratic, Intermittent, or Incorrect. Communication between multiple engines may be intermittent.	
238	Sensor Supply 3 Circuit - Voltage Below Normal, or Shorted to Low Source. Low voltage detected on the +5 volt sensor supply circuit to the engine speed sensor.	Possible hard starting and rough running.
241	Wheel-based vehicle speed - Data erratic, intermittent, or incorrect. The ECM lost the vehicle speed signal.	Engine speed limited to ,mximum engine speed without VSS parameter value. Cruise control, gear-down protection, and road speed governor will not work.
242	Wheel-based vehicle speed sensor circuit tampering has been detected - Abnormal rate of change. Signal indicates an intermittent connection or VSS tampering.	Engine speed limited to maximum engine speed without VSS parameter value. Cruise control, gear-down protection, and road speed g+H53overnor will not work.
245	Fan control circuit - Voltage below normal, or shorted to low source. Low signal voltage detected at the fan control circuit when commanded on.	The fan may stay on continuously or not run at all.
271	Fuel pump pressurizing assembly 1 circuit - Voltage below normal, or shorted to low source. Low signal voltage detected at the fuel pump actuator circuit.	Engine will run poorly at idle. Engine will have low power. Fuel pressure will be higher than commanded.
272	Fuel pump pressurizing assembly 1 circuit - Voltage above normal, or shorted to high source. High signal voltage or open circuit detected at the fuel pump actuator circuit.	Engine will not run or engine will run poorly.
281	Fuel pump pressurizing assembly 1 - Mechanical system not responding properly or out of adjustment.	Engine will not run or possible low power.
285	SAE J1939 multiplexing PGN timeout error - Abnormal update rate. The ECM expected information from a multiplexed device but did not receive it soon enough or did not receive it at all.	At least one multiplexed device will not operate properly.
286	SAE J1939 multiplexing configuration error - Out of calibration. The ECM expected information from a multiplexed device but only received a portion of the necessary information.	At least one multiplexed device will not operate properly.
287	SAE J1939 multiplexed accelerator pedal or lever sensor system - received network data In error. The OEM vehicle electronic control unit (VECU) detected a fault with its accelerator pedal.	Engine may only idle or engine will not accelerate to full speed.

Fault code No.	Reason	Effect (only when fault code is active)
288	SAE J1939 Multiplexing Remote Accelerator Pedal or Lever Position Sensor Circuit - Received Network Data In Error. The OEM vehicle electronic control unit (VECU) detected a fault with the remote accelerator.	The engine will not respond to the remote throttle. Engine may only idle. The primary or cab accelerator may be able to be used.
292	Auxiliary temperature Sensor Input 1 - Special instructions.	Possible engine power derate.
293	Auxiliary temperature sensor input 1 circuit - Voltage above normal, or shorted to high source. High signal voltage or open circuit detected at the OEM auxiliary temperature circuit.	None on performance.
294	Auxiliary temperature sensor input 1 circuit - Voltage below normal, or shorted to low source. Low signal voltage detected at the OEM auxiliary temperature circuit.	None on performance.
296	Auxiliary pressure sensor input 1 - Special instructions.	Possible engine power derate.
297	Auxiliary pressure sensor input 1 circuit - Voltage above normal, or shorted to high source. High signal voltage detected at the OEM pressure circuit.	None on performance.
298	Auxiliary pressure sensor input 1 circuit - Voltage below normal, or shorted to low source. Low signal voltage or open circuit detected at the OEM pressure circuit.	None on performance.
319	Real time clock power interrupt - Data erratic, intermittent, or incorrect. Real time clock lost power.	None on performance. Data in the ECM will not have accurate time and date information.
322	Injector solenoid driver cylinder 1 circuit - Current below normal, or open circuit. High resistance detected on injector number 1 circuit or no current detected at number 1 injector driver or return pin when the voltage supply at the harness is on.	Engine can possibly misfire or run rough.
323	Injector solenoid driver cylinder 5 circuit - Current below normal, or open circuit. High resistance detected on injector number 5 circuit or no current detected at number 5 injector driver or return pin when the voltage supply at the harness is on.	Engine can possibly misfire or run rough.
324	Injector solenoid driver cylinder 3 circuit - Current below normal, or open circuit. High resistance detected on injector number 3 circuit or no current detected at number 3 injector driver or return pin when the voltage supply at the harness is on.	Engine can possibly misfire or run rough.
325	Injector solenoid driver cylinder 6 circuit - Current below normal, or open circuit. High resistance detected on injector number 6 circuit or no current detected at number 6 injector driver or return pin when the voltage supply at the harness is on.	Engine can possibly misfire or run rough.

Fault code No.	Reason	Effect (only when fault code is active)
331	Injector solenoid driver cylinder 2 circuit - Current below normal, or open circuit. High resistance detected on injector number 2 circuit or no current detected at number 2 injector driver or return pin when the voltage supply at the harness is on.	Engine can possibly misfire or run rough.
332	Injector solenoid driver cylinder 4 circuit - Current below normal, or open circuit. High resistance detected on injector number 4 circuit or no current detected at number 4 injector driver or return pin when the voltage supply at the harness is on.	Engine can possibly misfire or run rough.
334	Engine coolant temperature - Data erratic, intermittent, or incorrect. The engine coolant temperature reading is not changing with engine operating conditions.	The ECM will estimate engine coolant temperature.
342	Electronic calibration code incompatibility - Out of calibration. An incompatible calibration has been detected in the ECM.	Possible no noticeable performance effects, engine dying, or hard starting.
343	Engine control module warning internal hardware failure - Bad intelligent device or component. Internal ECM failure.	No performance effects or possible severe power derate.
351	Injector power supply - Bad intelligent device or component. The ECM measured injector boost voltage is low.	Possible smoke, low power, engine misfire, and/or engine will not start.
352	Sensor supply 1 circuit - Voltage below normal, or shorted to low source. Low voltage detected at sensor supply number 1 circuit.	Engine power derate.
386	Sensor supply 1 circuit - Voltage above normal, or shorted to high source. High voltage detected at sensor supply number 1 circuit.	Engine power derate.
415	Engine oil rifle pressure - Data valid but below normal operational range - Most severe level. Oil pressure signal indicates oil pressure below the engine protection critical limit.	Progressive power derate increasing in severity from time of alert. If engine protection shutdown feature is enabled, engine will shut down 30 seconds after red stop lamp starts flashing.
418	Water in fuel indicator - Data valid but above normal operational range - Least severe level. water has been detected in the fuel filter.	Possible white smoke, loss of power, or hard starting.
428	Water in fuel indicator sensor circuit - Voltage above normal, or shorted to high source. High voltage detected at the water in fuel circuit.	None on performance. No water in fuel warning available.
429	Water in fuel indicator sensor circuit - Voltage below normal, or shorted to low source. Low voltage detected at the water in fuel circuit.	None on performance. No water in fuel warning available.
431	Accelerator pedal or lever idle validation switch - Data erratic, intermittent, or incorrect. Voltage detected simultaneously on both idle validation and off-idle validation switches.	Engine will only idle.
432	Accelerator pedal or lever idle validation circuit - Out of calibration. Voltage at idle validation on-idle and off-idle circuit does not match accelerator pedal position.	Engine will only idle.
435	Engine oil rifle pressure - Data erratic, intermittent, or incorrect. An error in the engine oil pressure switch signal was detected by the ECM.	None on performance. No engine protection for oil pressure.

Fault code No.	Reason	Effect (only when fault code is active)
441	Battery 1 voltage - Data valid but below normal operational range - Moderately severe level. ECM supply voltage is below the minimum system voltage level.	Engine may stop running or be difficult to start.
442	Battery 1 Voltage - Data valid but above normal operational range - Moderately severe level. ECM supply voltage is above the maximum system voltage level.	Possible electrical damage to all electrical components.
449	Injector metering rail 1 pressure - Data valid but above normal operational range - Most severe level.	None or possible engine noise associated with higher injection pressures (especially at idle or light load). Engine power is reduced.
451	Injector metering rail 1 pressure sensor circuit - Voltage above normal, or shorted to high source. High signal voltage detected at the rail fuel pressure sensor circuit.	Power and or speed derate.
452	Injector metering rail 1 pressure sensor circuit - Voltage below normal, or shorted to low source. Low signal voltage detected at the rail fuel pressure sensor circuit.	Power and or speed derate.
488	Intake manifold 1 temperature - Data valid but above normal operational range - Moderately severe level. Intake manifold air temperature signal indicates intake manifold air temperature is above the engine protection warning limit.	Progressive power derate increasing in severity from time of alert.
497	Multiple unit synchronization switch - Data erratic, intermittent, or incorrect.	
523	Auxiliary intermediate (PTO) speed switch validation - Data erratic, intermittent, or incorrect.	None on performance.
527	Auxiliary input/output 2 circuit - Voltage above normal, or shorted to high source. High signal voltage or open circuit has been detected at the auxiliary input/output 2 circuit.	None on performance.
528	Auxiliary alternate torque validation switch - Data erratic, intermittent, or incorrect.	None on performance.
529	Auxiliary input/output 3 circuit - Voltage above normal, or shorted to high source. Low signal voltage has been detected at the auxiliary input/output 2 circuit.	
553	Injector metering rail 1 pressure - Data valid but above normal operational range - Moderately severe level. The ECM has detected that fuel pressure is higher than commanded pressure.	The ECM will estimate fuel pressure and power is reduced.
554	Injector metering rail 1 pressure - Data erratic, Intermittent, or incorrect. The ECM has detected that the fuel pressure signal is not changing.	Possibly hard to start, low power, or engine smoke.
559	Injector metering rail 1 pressure - Data Valid but Below Normal Operational Range - Moderately Severe Level. The ECM has detected that fuel pressure is lower than commanded pressure.	Either the engine will not start or the engine will not have starter lockout protection.
584	Starter relay driver circuit - Voltage above normal, or shorted to high source. Open circuit or high voltage detected at starter lockout circuit.	The engine will not have starter lockout protection.

Fault code No.	Reason	Effect (only when fault code is active)
585	Starter relay driver circuit - Voltage below normal, or shorted to low source. Low voltage detected at starter lockout circuit.	Engine power derate. The ECM uses an estimated turbocharger speed.
595	Turbocharger 1 speed - Data valid but above normal operational range - Moderately severe level. High turbocharger speed has been detected.	Amber lamp will light until high battery voltage condition is corrected.
599	Auxiliary commanded dual output shutdown - Special instructions.	None or possible engine noise associated with higher injection pressures (especially at idle or light load). Engine power is reduced.
687	Turbocharger 1 speed - Data valid but below normal operational range - Moderately severe level. Low turbocharger speed detected by the ECM.	Engine can run rough. Possibly poor starting capability. Engine runs using backup speed sensor. Engine power is reduced.
689	Engine crankshaft speed/position - Data erratic, intermittent, or incorrect. Loss of signal from crankshaft sensor.	Engine power derate.
691	Turbocharger 1 compressor inlet temperature circuit - Voltage above normal, or shorted to high source. High signal voltage detected at turbocharger compressor inlet air temperature circuit.	Engine power derate.
692	Turbocharger 1 compressor inlet temperature circuit - Voltage below normal, or shorted to low source. Low signal voltage detected at turbocharger compressor inlet air tempera	Engine will run derated. Excessive black smoke, hard start, and rough idle possible.
731	Engine speed / position camshaft and crankshaft misalignment - Mechanical system not responding properly or out of adjustment. mechanical misalignment between the crankshaft and camshaft engine speed sensors.	Possible no noticeable performance effects, engine dying, or hard starting.
757	Electronic control module data lost - Condition exists. Severe loss of data from the ECM.	Possible poor starting. Engine power derate.
778	Engine camshaft speed / position sensor - Data erratic, intermittent, or incorrect. The ECM has detected an error in the camshaft position sensor signal.	Possible engine power derate.
779	Auxiliary equipment sensor input 3 - Root cause not known.	Possible no noticeable performance effects or engine dying or hard starting. Fault information, trip information, and maintenance monitor data may be inaccurate.
1117	Power supply lost with ignition on - Data erratic, intermittent, or incorrect. Supply voltage to the ECM fell below 6.2 volts momentarily, or the ECM was not allowed to power down correctly (retain battery voltage for 30 seconds after key OFF).	Engine will shut down.
1633	OEM datalink cannot transmit - Data erratic, intermittent, or incorrect. Communications within the OEM datalink network is intermittent.	Engine will only idle.
2185	Sensor supply 4 circuit - Voltage above normal, or shorted to high source. High voltage detected at +5 volt sensor supply circuit to the accelerator pedal position sensor.	Engine will only idle.

Fault code No.	Reason	Effect (only when fault code is active)
2186	Sensor supply 4 circuit - Voltage below normal, or shorted to low source. Low voltage detected at +5 volt sensor supply circuit to the accelerator pedal position sensor.	Possibly hard to start, low power, or engine smoke.
2249	Injector metering rail 1 pressure - Data valid but below normal operational range - Most severe level. The ECM has detected that fuel pressure is lower than commanded pressure.	Engine may be difficult to start.
2265	Electric lift pump for engine fuel supply circuit - Voltage above normal, or shorted to high source. High voltage or open detected at the fuel lift pump signal circuit.	Engine may be difficult to start.
2266	Electric lift pump for engine fuel supply circuit - Voltage below normal, or shorted to low source. Low signal voltage detected at the fuel lift pump circuit.	Possible low power.
2311	Electronic fuel injection control valve circuit - Condition exists. Fuel pump actuator circuit resistance too high or too low.	Engine may exhibit misfire as control switches from the primary to the backup speed sensor. Engine power is reduced while the engine operates on the backup speed sensor.
2321	Engine crankshaft speed/position - Data erratic, intermittent, or incorrect. crankshaft engine speed sensor intermittent synchronization.	Possible low power.
2322	Engine camshaft speed / position sensor - Data erratic, intermittent, or incorrect. Camshaft engine speed sensor intermittent synchronization.	Engine power derate.
2345	Turbocharger 1 Speed - Abnormal rate of change. The turbocharger speed sensor has detected an erroneous speed value.	Engine power derate.
2346	Turbocharger turbine inlet temperature (Calculated) - Data valid but above normal operational range - Least severe level. Turbocharger turbine inlet temperature has exceeded the engine protection limit.	Engine power derate.
2347	Turbocharger compressor outlet temperature (Calculated) - Data valid but above normal operational range - Least severe level.	Engine brake on cylinders 1, 2, and 3 can not be activated or exhaust brake will not operate.
2377	Fan control circuit - Voltage above normal, or shorted to high source. Open circuit or high voltage detected at the fan control circuit.	Variable geometry turbocharger will go to the open position.
2384	VGT actuator driver circuit - Voltage below normal, or shorted to low source. Low voltage detected at turbocharger control valve circuit.	Variable geometry turbocharger may be in either the open or closed position.
2385	VGT actuator driver circuit - Voltage above normal, or shorted to high source. Open circuit or high voltage detected at turbocharger control valve circuit.	The intake air heaters may be ON or OFF all the time.
2555	Intake air heater 1 circuit - Voltage above normal, or shorted to high source. High voltage detected at the intake air heater signal circuit.	The intake air heaters may be ON or OFF all the time.
2556	Intake air heater 1 circuit - Voltage below normal, or shorted to low source. Low voltage detected at the intake air heater signal circuit.	Can not control transmission.
2557	Auxiliary PWM driver 1 circuit - Voltage above normal, or shorted to high source. High signal voltage detected at the analog torque circuit.	Can not control transmission.

Fault code No.	Reason	Effect (only when fault code is active)
2558	Auxiliary PWM driver 1 circuit - Voltage below normal, or shorted to low source. Low signal voltage detected at the analog torque circuit.	Power derate and possible engine shutdown if engine protection shutdown feature is enabled.
2973	Intake manifold 1 pressure - Data erratic, intermittent, or incorrect. The ECM has detected an intake manifold pressure signal that is too high or low for current engine operating conditions.	

(7) DEFINITION OF OPERATING MODES

① Normal

There's no failure detected in the transmission system or the failure has no or slight effects on transmission control. TCU will work without or in special cases with little limitations.(See following table)

② Substitute clutch control

TCU can't change the gears or the direction under the control of the normal clutch modulation. TCU uses the substitute strategy for clutch control. All modulations are only time controlled. (Comparable with EST 25)

③ Limp-home

The detected failure in the system has strong limitations to transmission control. TCU can engage only one gear in each direction. In some cases only one direction will be possible. TCU will shift the transmission into neutral at the first occurrence of the failure. First, the operator must shift the gear selector into neutral position.

If output speed is less than a threshold for neutral to gear and the operator shifts the gear selector into forward or reverse, the TCU will select the limp-home gear.

If output speed is less than a threshold for reversal speed and TCU has changed into the limp-home gear and the operator selects a shuttle shift, TCU will shift immediately into the limp-home gear of the selected direction.

If output speed is greater than the threshold, TCU will shift the transmission into neutral. The operator has to slow down the vehicle and must shift the gear selector into neutral position.

④ Transmission-shutdown

TCU has detected a severe failure that disables control of the transmission.

TCU will shut off the solenoid valves for the clutches and also the common power supply(VPS1).

Transmission shifts to neutral. The park brake will operate normally, also the other functions which use ADM1 to ADM8.

The operator has to slow down the vehicle. The transmission will stay in neutral.

⑤ TCU-shutdown

TCU has detected a severe failure that disables control of system.

TCU will shut off all solenoid valves and also both common power supplies(VPS1, VPS2). The park brake will engage, also functions are disabled which use ADM 1 to ADM 8.

The transmission will stay in neutral.

※ Abbreviations

OC : Open circuit

SC : Short circuit

OP mode : Operating mode

TCU : Transmission control unit

EEC : Electronic engine controller

PTO : Power take off

(8) Transmission fault codes

Fault code (Hex)	Meaning of the fault code possible reason for fault detection	Reaction of the TCU	Possible steps to repair
11	Logical error at gear range signal TCU detected a wrong signal combination for the gear range <ul style="list-style-type: none"> • Cable from shift lever to TCU is broken • Cable is defective and is contacted to battery voltage or vehicle ground • Shift lever is defective 	TCU shifts transmission to neutral OP-mode : Transmission shutdown	<ul style="list-style-type: none"> • Check the cables from TCU to shift lever • Check signal combinations of shift lever positions for gear range ※ Failure cannot be detected in systems with DW2/DW3 shift lever. Fault is taken back if TCU detects a valid signal for the position
12	Logical error at direction select signal TCU detected a wrong signal combination for the direction <ul style="list-style-type: none"> • Cable from shift lever to TCU is broken • Cable is defective and is contacted to battery voltage or vehicle ground • Shift lever is defective 	TCU shifts transmission to neutral OP-Mode : Transmission shutdown	<ul style="list-style-type: none"> • Check the cables from TCU to shift lever • Check signal combinations of shift lever positions F-N-R ※ Fault is taken back if TCU detects a valid signal for the direction at the shift lever
13	Logical error at engine derating device TCU detected no reaction of engine while derating device active	After selecting neutral, TCU change to OP mode limp home	<ul style="list-style-type: none"> • Check engine derating device ※ This fault is reset after power up of TCU
15	Logical error at direction select signal 2 shift lever TCU detected a wrong signal combination for the direction <ul style="list-style-type: none"> • Cable from shift lever 2 to TCU is broken • Cable is defective and is contacted to battery voltage or vehicle ground • Shift lever is defective 	TCU shifts transmission to neutral if selector active OP mode : Transmission shutdown if selector active	<ul style="list-style-type: none"> • Check the cables from TCU to shift lever 2 • Check signal combinations of shift lever positions F-N-R ※ Fault is taken back if TCU detects a valid neutral signal for the direction at the shift lever
16	Logical error at axle connection Feedback axle connection measured by TCU and output signal axle connection don't fit <ul style="list-style-type: none"> • Axle can't be connected or disconnected due to mechanical problem • One of the cables from feedback axle connection switch to TCU is broken 	OP mode : Normal	<ul style="list-style-type: none"> • Check the cables from TCU to feedback axle connection switch • Check signals of the feedback axle connection switch
21	S.C. to battery voltage at clutch cut off input The measured voltage is too high: <ul style="list-style-type: none"> • Cable is defective and is contacted to battery voltage • Clutch cut off sensor has an internal defect • Connector pin is contacted to battery voltage 	Clutch cut off function is disabled OP mode : Normal	<ul style="list-style-type: none"> • Check the cable from TCU to the sensor • Check the connectors • Check the clutch cut off sensor
22	S.C. to ground or O.C. at clutch cut off input The measured voltage is too low: <ul style="list-style-type: none"> • Cable is defective and is contacted to vehicle ground • Cable has no connection to TCU • Clutch cut off sensor has an internal defect • Connector pin is contacted to vehicle ground or is broken 	Clutch cut off function is disabled OP mode : Normal	<ul style="list-style-type: none"> • Check the cable from TCU to the sensor • Check the connectors • Check the clutch cut off sensor

Fault code (Hex)	Meaning of the fault code possible reason for fault detection	Reaction of the TCU	Possible steps to repair
23	<p>S.C. to battery voltage at load sensor input</p> <p>The measured voltage is too high:</p> <ul style="list-style-type: none"> • Cable is defective and is contacted to battery voltage • Load sensor has an internal defect • Connector pin is contacted to battery voltage 	<p>Retarder function is affected</p> <p>TCU uses default load</p> <p>OP mode : Normal</p>	<ul style="list-style-type: none"> • Check the cable from TCU to the sensor • Check the connectors • Check the load sensor • Check the assembly tolerances of load sensor <p>※ Availability of retarder depends on default load</p>
24	<p>S.C. to ground or O.C. at load sensor input</p> <p>The measured voltage is too low:</p> <ul style="list-style-type: none"> • Cable is defective and is contacted to vehicle ground • Cable has no connection to TCU • Load sensor has as internal defect • Connector pin is contacted to vehicle ground or is broken 	<p>Retarder function is affected</p> <p>TCU use default load</p> <p>OP mode : Normal</p>	<ul style="list-style-type: none"> • Check the cable from TCU to the sensor • Check the connectors • Check the load sensor • Check the assembly tolerances of load sensor <p>※ Availability of retarder depends on default load</p>
25	<p>S.C. to battery voltage or O.C. at transmission sump temperature sensor input</p> <p>The measured voltage is too high:</p> <ul style="list-style-type: none"> • Cable is defective and is contacted to battery voltage • Cable has no connection to TCU • Temperature sensor has an internal defect • Connector pin is contacted to battery voltage or is broken 	<p>No reaction, TCU use default temperature</p> <p>OP mode : Normal</p>	<ul style="list-style-type: none"> • Check the cable from TCU to the sensor • Check the connectors • Check the temperature sensor
26	<p>S.C. to battery voltage or O.C. at transmission sump temperature sensor input</p> <p>The measured voltage is too low:</p> <ul style="list-style-type: none"> • Cable is defective and is contacted to vehicle ground • Temperature sensor has an internal defect • Connector pin is contacted to vehicle ground 	<p>No reaction, TCU uses default temperature</p> <p>OP mode : Normal</p>	<ul style="list-style-type: none"> • Check the cable from TCU to the sensor • Check the connectors • Check the temperature sensor
27	<p>S.C. to battery voltage or O.C. at retarder temperature sensor input</p> <p>The measured voltage is too high:</p> <ul style="list-style-type: none"> • Cable is defective and is contacted to battery voltage • Cable has no connection to TCU • Temperature sensor has an internal defect • Connector pin is contacted to battery voltage or is broken 	<p>No reaction, TCU uses default temperature</p> <p>OP mode : Normal</p>	<ul style="list-style-type: none"> • Check the cable from TCU to the sensor • Check the connectors • Check the temperature sensor

Fault code (Hex)	Meaning of the fault code possible reason for fault detection	Reaction of the TCU	Possible steps to repair
28	<p>S.C. to ground at retarder temperature sensor input</p> <p>The measured voltage is too low:</p> <ul style="list-style-type: none"> • Cable is defective and is contacted to vehicle ground • Temperature sensor has an internal defect • Connector pin is contacted to vehicle ground 	<p>No reaction, TCU uses default temperature</p> <p>OP mode : Normal</p>	<ul style="list-style-type: none"> • Check the cable from TCU to the sensor • Check the connectors • Check the temperature sensor
29	<p>S.C. to battery voltage or O.C. at converter output temperature sensor input</p> <p>The measured voltage is too high:</p> <ul style="list-style-type: none"> • Cable is defective and is contacted to battery voltage • Cable has no connection to TCU • Temperature sensor has an internal defect • Connector pin is contacted to battery voltage or is broken 	<p>No reaction, TCU uses default temperature</p> <p>OP mode : Normal</p>	<ul style="list-style-type: none"> • Check the cable from TCU to the sensor • Check the connectors • Check the temperature sensor
30	<p>S.C. to ground at converter output temperature sensor input</p> <p>The measured voltage is too low:</p> <ul style="list-style-type: none"> • Cable is defective and is contacted to vehicle ground • Temperature sensor has an internal defect • Connector pin is contacted to vehicle ground 	<p>No reaction, TCU uses default temperature</p> <p>OP mode : Normal</p>	<ul style="list-style-type: none"> • Check the cable from TCU to the sensor • Check the connectors • Check the temperature sensor
31	<p>S.C. to battery voltage or O.C. at engine speed input</p> <p>TCU measures a voltage higher than 7.00V at speed input pin</p> <ul style="list-style-type: none"> • Cable is defective and is contacted to battery voltage • Cable has no connection to TCU • Speed sensor has an internal defect • Connector pin is contacted to battery voltage or has no contact 	<p>OP mode : Substitute clutch control</p>	<ul style="list-style-type: none"> • Check the cable from TCU to the sensor • Check the connectors • Check the speed sensor
32	<p>S.C. to ground at engine speed input</p> <p>TCU measures a voltage less than 0.45V at speed input pin</p> <ul style="list-style-type: none"> • Cable/connector is defective and is contacted to vehicle ground • Speed sensor has an internal defect 	<p>OP mode : Substitute clutch control</p>	<ul style="list-style-type: none"> • Check the cable from TCU to the sensor • Check the connectors • Check the speed sensor

Fault code (Hex)	Meaning of the fault code possible reason for fault detection	Reaction of the TCU	Possible steps to repair
33	<p>Logical error at engine speed input TCU measures a engine speed over a threshold and the next moment the measured speed is zero</p> <ul style="list-style-type: none"> • Cable/connector is defective and has bad contact • Speed sensor has an internal defect • Sensor gap has the wrong size 	OP mode : Substitute clutch control	<ul style="list-style-type: none"> • Check the cable from TCU to the sensor • Check the connectors • Check the speed sensor • Check the sensor gap <p>※ This fault is reset after power up of TCU</p>
34	<p>S.C. to battery voltage or O.C. at turbine speed input TCU measures a voltage higher than 7.00V at speed input pin</p> <ul style="list-style-type: none"> • Cable is defective and is contacted to vehicle battery voltage • Cable has no connection to TCU • Speed sensor has an internal defect • Connector pin is contacted to battery voltage or has no contact 	OP mode : Substitute clutch control If a failure is existing at output speed, TCU shifts to neutral OP mode : Limp home	<ul style="list-style-type: none"> • Check the cable from TCU to the sensor • Check the connectors • Check the speed sensor
35	<p>S.C. to ground at turbine speed input TCU measures a voltage less than 0.45V at speed input pin</p> <ul style="list-style-type: none"> • Cable/connector is defective and is contacted to vehicle ground • Speed sensor has an internal defect 	OP mode : Substitute clutch control If a failure is existing at output speed, TCU shifts to neutral OP mode : Limp home	<ul style="list-style-type: none"> • Check the cable from TCU to the sensor • Check the connectors • Check the speed sensor <p>※ This fault is reset after power up of TCU</p>
36	<p>Logical error at turbine speed input TCU measures a turbine speed over a threshold and at the next moment the measured speed is zero</p> <ul style="list-style-type: none"> • Cable/connector is defective and has bad contact • Speed sensor has an internal defect • Sensor gap has the wrong size 	OP mode : Substitute clutch control If a failure is existing at output speed, TCU shifts to neutral OP mode : Limp home	<ul style="list-style-type: none"> • Check the cable from TCU to the sensor • Check the connectors • Check the speed sensor • Check the sensor gap
37	<p>S.C. to battery voltage or O.C. at internal speed input TCU measures a voltage higher than 7.00V at speed input pin</p> <ul style="list-style-type: none"> • Cable is defective and is contacted to vehicle battery voltage • Cable has no connection to TCU • Speed sensor has an internal defect • Connector pin is contacted to battery voltage or has no contact 	OP mode : Substitute clutch control	<ul style="list-style-type: none"> • Check the cable from TCU to the sensor • Check the connectors • Check the speed sensor
38	<p>S.C. to ground at turbine speed input TCU measures a voltage less than 0.45V at speed input pin</p> <ul style="list-style-type: none"> • Cable/connector is defective and is contacted to vehicle ground • Speed sensor has an internal defect 	OP mode : Substitute clutch control	<ul style="list-style-type: none"> • Check the cable from TCU to the sensor • Check the connectors • Check the speed sensor

Fault code (Hex)	Meaning of the fault code possible reason for fault detection	Reaction of the TCU	Possible steps to repair
39	<p>Logical error at internal speed input TCU measures a internal speed over a threshold and at the next moment the measured speed is zero</p> <ul style="list-style-type: none"> • Cable/connector is defective and has bad contact • Speed sensor has an internal defect • Sensor gap has the wrong size 	OP mode : Substitute clutch control	<ul style="list-style-type: none"> • Check the cable from TCU to the sensor • Check the connectors • Check the speed sensor • Check the sensor gap <p>※ This fault is reset after power up of TCU</p>
3A	<p>S.C. to battery voltage or O.C. at output speed input TCU measures a voltage higher than 12.5V at speed input pin</p> <ul style="list-style-type: none"> • Cable is defective and is contacted to battery voltage • Cable has no connection to TCU • Speed sensor has an internal defect • Connector pin is contacted to battery voltage or has no contact 	<p>Special mode for gear selection OP mode : Substitute clutch control</p> <p>If a failure is existing at turbine speed, TCU shifts to neutral OP mode : lamp home</p>	<ul style="list-style-type: none"> • Check the cable from TCU to the sensor • Check the connectors • Check the speed sensor
3B	<p>S.C. to ground at output speed input TCU measures a voltage less than 1.00V at speed input pin</p> <ul style="list-style-type: none"> • Cable/connector is defective and is contacted to vehicle ground • Speed sensor has an internal defect 	<p>Special mode for gear selection OP mode : Substitute clutch control</p> <p>If a failure is existing at turbine speed, TCU shifts to neutral OP mode : lamp home</p>	<ul style="list-style-type: none"> • Check the cable from TCU to the sensor • Check the connectors • Check the speed sensor
3C	<p>Logical error at output speed input TCU measures a turbine speed over a threshold and at the next moment the measured speed is zero</p> <ul style="list-style-type: none"> • Cable/connector is defective and has bad contact • Speed sensor has an internal defect • Sensor gap has the wrong size 	<p>Special mode for gear selection OP mode : Substitute clutch control</p> <p>If a failure is existing at turbine speed, TCU shifts to neutral OP mode : lamp home</p>	<ul style="list-style-type: none"> • Check the cable from TCU to the sensor • Check the connectors • Check the speed sensor • Check the sensor gap <p>※ This fault is reset after power up of TCU</p>
3D	Turbine speed zero doesn't fit to other speed signals	-	※ Not used
3E	<p>Output speed zero doesn't fit to other speed signals If transmission is not neutral and the shifting has finished, TCU measures output speed zero and turbine speed or internal speed not equal to zero.</p> <ul style="list-style-type: none"> • Speed sensor has an internal defect • Sensor gap has the wrong size 	<p>Special mode for gear selection OP mode : Substitute clutch control</p> <p>If a failure is existing at turbine speed, TCU shifts to neutral OP mode : lamp home</p>	<ul style="list-style-type: none"> • Check the sensor signal of output speed sensor • Check the sensor gap of output speed sensor • Check the cable from TCU to the sensor <p>※ This fault is reset after power up of TCU</p>

Fault code (Hex)	Meaning of the fault code possible reason for fault detection	Reaction of the TCU	Possible steps to repair
71	<p>S.C. to battery voltage at clutch K1 The measured resistance value of the valve is out of limit, the voltage at K1 valve is too high</p> <ul style="list-style-type: none"> • Cable/connector is defective and has contact to battery voltage • Cable/connector is defective and has contact to another regulator output of the TCU • Regulator has an internal defect 	<p>TCU shifts to neutral OP mode : Limp home If failure at another clutch is pending TCU shifts to neutral OP mode : TCU shutdown</p>	<ul style="list-style-type: none"> • Check the cable from TCU to the gearbox • Check the connectors from TCU to the gearbox • Check the regulator resistance* • Check internal wire harness of the gearbox <p>* See page 3-52</p>
72	<p>S.C. to ground at clutch K1 The measured resistance value of the valve is out of limit, the voltage at K1 valve is too low</p> <ul style="list-style-type: none"> • Cable/connector is defective and has contact to vehicle ground • Regulator has an internal defect 	<p>TCU shifts to neutral OP mode : Limp home If failure at another clutch is pending TCU shifts to neutral OP mode : TCU shutdown</p>	<ul style="list-style-type: none"> • Check the cable from TCU to the gearbox • Check the connectors from gearbox to TCU • Check the regulator resistance* • Check internal wire harness of the gearbox <p>* See page 3-52</p>
73	<p>O.C. at clutch K1 The measured resistance value of the valve is out of limit</p> <ul style="list-style-type: none"> • Cable/connector is defective and has no contact to TCU • Regulator has an internal defect 	<p>TCU shifts to neutral OP mode : Limp home If failure at another clutch is pending TCU shifts to neutral OP mode : TCU shutdown</p>	<ul style="list-style-type: none"> • Check the cable from TCU to the gearbox • Check the connectors from gearbox to TCU • Check the regulator resistance* • Check internal wire harness of the gearbox <p>* See page 3-52</p>
74	<p>S.C. to battery voltage at clutch K2 The measured resistance value of the valve is out of limit, the voltage at K2 valve is too high</p> <ul style="list-style-type: none"> • Cable/connector is defective and has contact to battery voltage • Cable/connector is defective and has contact to another regulator output of the TCU • Regulator has an internal defect 	<p>TCU shifts to neutral OP mode : Limp home If failure at another clutch is pending TCU shifts to neutral OP mode : TCU shutdown</p>	<ul style="list-style-type: none"> • Check the cable from TCU to the gearbox • Check the connectors from gearbox to TCU • Check the regulator resistance* • Check internal wire harness of the gearbox <p>* See page 3-52</p>
75	<p>S.C. to ground at clutch K2 The measured resistance value of the valve is out of limit, the voltage at K2 valve is too low</p> <ul style="list-style-type: none"> • Cable/connector is defective and has contact to vehicle ground • Regulator has an internal defect 	<p>TCU shifts to neutral OP mode : Limp home If failure at another clutch is pending TCU shifts to neutral OP mode : TCU shutdown</p>	<ul style="list-style-type: none"> • Check the cable from TCU to the gearbox • Check the connectors from gearbox to TCU • Check the regulator resistance* • Check internal wire harness of the gearbox <p>* See page 3-52</p>
76	<p>O.C. at clutch K2 The measured resistance value of the valve is out of limit</p> <ul style="list-style-type: none"> • Cable/connector is defective and has no contact to TCU • Regulator has an internal defect 	<p>TCU shifts to neutral OP mode : Limp home If failure at another clutch is pending TCU shifts to neutral OP mode : TCU shutdown</p>	<ul style="list-style-type: none"> • Check the cable from TCU to the gearbox • Check the connectors from gearbox to TCU • Check the regulator resistance* • Check internal wire harness of the gearbox <p>* See page 3-52</p>

Fault code (Hex)	Meaning of the fault code possible reason for fault detection	Reaction of the TCU	Possible steps to repair
77	<p>S.C. to battery voltage at clutch K3 The measured resistance value of the valve is out of limit, the voltage at K3 valve is too high</p> <ul style="list-style-type: none"> • Cable/connector is defective and has contact to battery voltage • Cable/connector is defective and has contact to another regulator output of the TCU • Regulator has an internal defect 	<p>TCU shifts to neutral OP mode : Limp home If failure at another clutch is pending TCU shifts to neutral OP mode : TCU shutdown</p>	<ul style="list-style-type: none"> • Check the cable from TCU to the gearbox • Check the connectors from gearbox to TCU • Check the regulator resistance* • Check internal wire harness of the gearbox <p>* See page 3-52</p>
78	<p>S.C. to ground at clutch K3 The measured resistance value of the valve is out of limit, the voltage at K3 valve is too low</p> <ul style="list-style-type: none"> • Cable/connector is defective and has contact to vehicle ground • Regulator has an internal defect 	<p>TCU shifts to neutral OP mode : Limp home If failure at another clutch is pending TCU shifts to neutral OP mode : TCU shutdown</p>	<ul style="list-style-type: none"> • Check the cable from TCU to the gearbox • Check the connectors from gearbox to TCU • Check the regulator resistance* • Check internal wire harness of the gearbox <p>* See page 3-52</p>
79	<p>O.C. at clutch K2 The measured resistance value of the valve is out of limit Cable/connector is defective and has no contact to TCU Regulator has an internal defect</p>	<p>TCU shifts to neutral OP mode : Limp home If failure at another clutch is pending TCU shifts to neutral OP mode : TCU shutdown</p>	<ul style="list-style-type: none"> • Check the cable from TCU to the gearbox • Check the connectors from gearbox to TCU • Check the regulator resistance* • Check internal wire harness of the gearbox <p>* See page 3-52</p>
7A	S.C. to battery voltage at converter clutch	-	-
7B	S.C. to ground at converter clutch	-	-
7C	O.C. at converter clutch	-	※ Not used
7D	<p>S.C. ground at engine derating device</p> <ul style="list-style-type: none"> • Cable is defective and is contacted to vehicle ground • Engine derating device has an internal defect • Connector pin is contacted to vehicle ground 	<p>Engine derating will be on until TCU power down even if fault vanishes(Loose connection) OP mode : Normal</p>	<ul style="list-style-type: none"> • Check the cable from TCU to the engine derating device • Check the connectors from engine derating device to TCU • Check the resistance* of engine derating device <p>※ Not used * See page 3-52</p>
7E	<p>S.C. battery voltage at engine derating device</p> <ul style="list-style-type: none"> • Cable/connector is defective and is contacted to battery voltage • Engine derating device has an internal defect 	<p>No reaction OP mode : Normal</p>	<ul style="list-style-type: none"> • Check the cable from TCU to the engine derating device • Check the connectors from backup alarm device to TCU • Check the resistance* of backup alarm device <p>* See page 3-52</p>

Fault code (Hex)	Meaning of the fault code possible reason for fault detection	Reaction of the TCU	Possible steps to repair
7F	<p>O.C. at engine derating device TCU detected a wrong voltage at the output pin, that looks like a O.C. for this output pin</p> <ul style="list-style-type: none"> • Cable is defective and has no connection to TCU • Engine derating device has an internal defect • Connector has no connection to TCU 	<p>No reaction OP mode : Normal</p>	<ul style="list-style-type: none"> • Check the cable from TCU to the engine derating device • Check the connectors from engine derating device to TCU • Check the resistance* of engine derating device <p>* See page 3-52</p>
81	<p>S.C. to battery voltage at clutch K4 The measured resistance value of the valve is out of limit, the voltage at K4 valve is too high</p> <ul style="list-style-type: none"> • Cable/connector is defective and has contact to battery voltage • Cable/connector is defective and has contact to another regulator output of the TCU • Regulator has an internal defect 	<p>TCU shifts to neutral OP mode : Limp home If failure at another clutch is pending TCU shifts to neutral OP mode : TCU shutdown</p>	<ul style="list-style-type: none"> • Check the cable from TCU to the gearbox • Check the connectors from gearbox to TCU • Check the regulator resistance* • Check internal wire harness of the gearbox <p>* See page 3-52</p>
82	<p>S.C. to ground at clutch K4 The measured resistance value of the valve is out of limit, the voltage at K4 valve is too low</p> <ul style="list-style-type: none"> • Cable/connector is defective and has contact to vehicle ground • Regulator has an internal defect 	<p>TCU shifts to neutral OP mode : Limp home If failure at another clutch is pending TCU shifts to neutral OP mode : TCU shutdown</p>	<ul style="list-style-type: none"> • Check the cable from TCU to the engine derating device • Check the connectors from gearbox to TCU • Check the regulator resistance* • Check internal wire harness of the gearbox <p>* See page 3-52</p>
83	<p>O.C. at clutch K4 The measured resistance value of the valve is out of limit</p> <ul style="list-style-type: none"> • Cable/connector is defective and has contact to TCU • Regulator has an internal defect 	<p>TCU shifts to neutral OP mode : Limp home If failure at another clutch is pending TCU shifts to neutral OP mode : TCU shutdown</p>	<ul style="list-style-type: none"> • Check the cable from TCU to the gearbox • Check the connectors from gearbox to TCU • Check the regulator resistance* • Check internal wire harness of the gearbox <p>* See page 3-52</p>
84	<p>S.C. to battery voltage at clutch K4 The measured resistance value of the valve is out of limit, the voltage at K4 valve is too high</p> <ul style="list-style-type: none"> • Cable/connector is defective and has contact to battery voltage • Cable/connector is defective and has contact to another regulator output of the TCU • Regulator has an internal defect 	<p>TCU shifts to neutral OP mode : Limp home If failure at another clutch is pending TCU shifts to neutral OP mode : TCU shutdown</p>	<ul style="list-style-type: none"> • Check the cable from TCU to the gearbox • Check the connectors from gearbox to TCU • Check the regulator resistance* • Check internal wire harness of the gearbox <p>* See page 3-52</p>
85	<p>S.C. to ground at clutch KV The measured resistance value of the valve is out of limit, the voltage at K4 valve is too low</p> <ul style="list-style-type: none"> • Cable/connector is defective and has contact to vehicle ground • Regulator has an internal defect 	<p>TCU shifts to neutral OP mode : Limp home If failure at another clutch is pending TCU shifts to neutral OP mode : TCU shutdown</p>	<ul style="list-style-type: none"> • Check the cable from TCU to the gearbox • Check the connectors from gearbox to TCU • Check the regulator resistance* • Check internal wire harness of the gearbox <p>* See page 3-52</p>

Fault code (Hex)	Meaning of the fault code possible reason for fault detection	Reaction of the TCU	Possible steps to repair
86	<p>O.C. at clutch KV The measured resistance value of the valve is out of limit</p> <ul style="list-style-type: none"> • Cable/connector is defective and has contact to TCU • Regulator has an internal defect 	<p>TCU shifts to neutral OP mode : Limp home If failure at another clutch is pending TCU shifts to neutral OP mode : TCU shutdown</p>	<ul style="list-style-type: none"> • Check the cable from TCU to the gearbox • Check the connectors from gearbox to TCU • Check the regulator resistance* • Check internal wire harness of the gearbox <p>* See page 3-52</p>
87	<p>S.C. to battery voltage at clutch KR The measured resistance value of the valve is out of limit, the voltage at KR valve is too high</p> <ul style="list-style-type: none"> • Cable/connector is defective and has contact to battery voltage • Cable/connector is defective and has contact to another regulator output of the TCU • Regulator has an internal defect 	<p>TCU shifts to neutral OP mode : Limp home If failure at another clutch is pending TCU shifts to neutral OP mode : TCU shutdown</p>	<ul style="list-style-type: none"> • Check the cable from TCU to the gearbox • Check the connectors from gearbox to TCU • Check the regulator resistance* • Check internal wire harness of the gearbox <p>* See page 3-52</p>
88	<p>S.C. to ground at clutch KR The measured resistance value of the valve is out of limit, the voltage at KR valve is too low</p> <ul style="list-style-type: none"> • Cable/connector is defective and has contact to vehicle ground • Regulator has an internal defect 	<p>TCU shifts to neutral OP mode : Limp home If failure at another clutch is pending TCU shifts to neutral OP mode : TCU shutdown</p>	<ul style="list-style-type: none"> • Check the cable from TCU to the gearbox • Check the connectors from gearbox to TCU • Check the regulator resistance* • Check internal wire harness of the gearbox <p>* See page 3-52</p>
89	<p>O.C. at clutch KR The measured resistance value of the valve is out of limit</p> <ul style="list-style-type: none"> • Cable/connector is defective and has no contact to TCU • Regulator has an internal defect 	<p>TCU shifts to neutral OP mode : Limp home If failure at another clutch is pending TCU shifts to neutral OP mode : TCU shutdown</p>	<ul style="list-style-type: none"> • Check the cable from TCU to the gearbox • Check the connectors from gearbox to TCU • Check the regulator resistance* • Check internal wire harness of the gearbox <p>* See page 3-52</p>
91	<p>S.C. to ground at relay reverse warning alarm TCU detected a wrong voltage at the output pin, that looks like a S.C. to vehicle ground</p> <ul style="list-style-type: none"> • Cable is defective and is contact to vehicle ground • Backup alarm device has an internal defect • Connector pin is contacted to vehicle ground 	<p>Backup alarm will be on until TCU power down even if fault vanishes(Loose connection) OP mode : Normal</p>	<ul style="list-style-type: none"> • Check the cable from TCU to the backup alarm device • Check the connectors from backup alarm device to TCU • Check the resistance* of backup alarm device <p>* See page 3-52</p>

Fault code (Hex)	Meaning of the fault code possible reason for fault detection	Reaction of the TCU	Possible steps to repair
92	<p>S.C. to battery voltage at relay reverse warning alarm TCU detected a wrong voltage at the output pin, that looks like a S.C. to battery voltage</p> <ul style="list-style-type: none"> • Cable is defective and is contacted to battery voltage • Backup alarm device has an internal defect • Connector pin is contacted to battery voltage 	No reaction OP mode : Normal	<ul style="list-style-type: none"> • Check the cable from TCU to the backup alarm device • Check the connectors from backup alarm device to TCU • Check the resistance* of backup alarm device <p>* See page 3-52</p>
93	<p>O.C. at relay reverse warning alarm TCU detected a wrong voltage at the output pin, that looks like a O.C. for this output pin</p> <ul style="list-style-type: none"> • Cable is defective and has no connection to TCU • Backup alarm device has an internal defect • Connector has no connection to TCU 	No reaction OP mode : Normal	<ul style="list-style-type: none"> • Check the cable from TCU to the backup alarm device • Check the connectors from backup alarm device to TCU • Check the resistance* of backup alarm device <p>* See page 3-52</p>
94	<p>S.C. to ground at relay starter interlock TCU detected a wrong voltage at the output pin, that looks like a S.C. to vehicle ground</p> <ul style="list-style-type: none"> • Cable is defective and is connection to vehicle ground • Starter interlock relay has an internal defect • Connector pin is contacted to vehicle ground 	No reaction OP mode : Normal	<ul style="list-style-type: none"> • Check the cable from TCU to the stater interlock relay • Check the connectors from starter interlock relay to TCU • Check the resistance* of starter interlock relay <p>* See page 3-52</p>
95	<p>S.C. to battery voltage at relay starter interlock TCU detected a wrong voltage at the output pin, that looks like a S.C. to battery voltage</p> <ul style="list-style-type: none"> • Cable is defective and has no connection to battery voltage • Starter interlock relay has an internal defect • Connector pin is contacted to battery voltage 	No reaction OP mode : Normal	<ul style="list-style-type: none"> • Check the cable from TCU to the starter interlock relay • Check the connectors from starter interlock relay to TCU • Check the resistance* of starter interlock relay <p>* See page 3-52</p>
96	<p>O.C. at relay starter interlock TCU detected a wrong voltage at the output pin, that looks like a O.C. for this output pin</p> <ul style="list-style-type: none"> • Cable is defective and has no connection to TCU • Starter interlock relay has an internal defect • Connector has no connection to TCU 	No reaction OP mode : Normal	<ul style="list-style-type: none"> • Check the cable from TCU to the starter interlock relay • Check the connectors from starter interlock relay to TCU • Check the resistance* of starter interlock relay <p>* See page 3-52</p>

Fault code (Hex)	Meaning of the fault code possible reason for fault detection	Reaction of the TCU	Possible steps to repair
97	<p>S.C. to ground at park brake solenoid TCU detected a wrong voltage at the output pin, that looks like a S.C. to vehicle ground</p> <ul style="list-style-type: none"> • Cable is defective and is connection to vehicle ground • Park brake solenoid has an internal defect • Connector pin is contacted to vehicle ground 	<p>No reaction OP mode : Normal</p>	<ul style="list-style-type: none"> • Check the cable from TCU to the park brake solenoid • Check the connectors from park brake solenoid to TCU • Check the resistance* of park brake solenoid * See page 3-52
98	<p>S.C. to battery voltage at park brake solenoid TCU detected a wrong voltage at the output pin, that looks like a S.C. to battery voltage</p> <ul style="list-style-type: none"> • Cable is defective and is connection to battery voltage • Park brake solenoid has an internal defect • Connector pin is contacted to battery voltage 	<p>No reaction Optional : (Some customers) TCU shifts to neutral caused by park brake feed back OP mode : Normal</p>	<ul style="list-style-type: none"> • Check the cable from TCU to the park brake solenoid • Check the connectors from park brake solenoid to TCU • Check the resistance* of park brake solenoid * See page 3-52
99	<p>O.C. at park brake solenoid TCU detected a wrong voltage at the output pin, that looks like a O.C. for this output pin</p> <ul style="list-style-type: none"> • Cable is defective and has no connection to TCU • Park brake solenoid has an internal defect • Connector has no connection to TCU 	<p>No reaction Optional : Some customers TCU shifts to neutral caused by park brake feed back OP mode : Normal</p>	<ul style="list-style-type: none"> • Check the cable from TCU to the park brake solenoid • Check the connectors from park brake solenoid to TCU • Check the resistance* of park brake solenoid * See page 3-52
9A	<p>S.C. to ground at converter lock up clutch solenoid TCU detected a wrong voltage at the output pin, that looks like a S.C. to vehicle ground</p> <ul style="list-style-type: none"> • Cable is defective and is contacted to vehicle ground • Converter clutch solenoid has an internal defect • Connector pin is contacted to vehicle ground 	<p>No reaction OP mode : Normal</p>	<ul style="list-style-type: none"> • Check the cable from TCU to the converter clutch solenoid • Check the connectors from converter clutch solenoid to TCU • Check the resistance* of park brake solenoid * See page 3-52
9B	<p>O.C. at converter lock up clutch solenoid TCU detected a wrong voltage at the output pin, that looks like a O.C. for this output pin</p> <ul style="list-style-type: none"> • Cable is defective and has no connection to TCU • Converter clutch solenoid has an internal defect • Connector has no connection to TCU 	<p>Converter clutch always open, retarder not available OP mode : Normal</p>	<ul style="list-style-type: none"> • Check the cable from TCU to the converter clutch solenoid • Check the connectors from converter clutch solenoid to TCU • Check the resistance* of park brake solenoid * See page 3-52

Fault code (Hex)	Meaning of the fault code possible reason for fault detection	Reaction of the TCU	Possible steps to repair
9C	<p>S.C. to battery voltage at converter lock up clutch solenoid TCU detected a wrong voltage at the output pin, that looks like a S.C. to battery voltage</p> <ul style="list-style-type: none"> • Cable is defective and has no contacted to battery voltage • Converter clutch solenoid has an internal defect • Connector pin is contacted to battery voltage 	<p>No reaction OP mode : Normal</p>	<ul style="list-style-type: none"> • Check the cable from TCU to the converter clutch solenoid • Check the connectors from converter clutch solenoid to TCU • Check the resistance* of converter clutch solenoid <p>* See page 3-52</p>
9D	<p>S.C. to ground at retarder solenoid TCU detected a wrong voltage at the output pin, that looks like a S.C. to vehicle ground</p> <ul style="list-style-type: none"> • Cable is defective and is contacted to vehicle ground • Retarder solenoid has an internal defect • Connector pin is contacted to vehicle ground 	<p>No reaction OP mode : Normal</p>	<ul style="list-style-type: none"> • Check the cable from TCU to the retarder solenoid • Check the connectors from retarder solenoid to TCU • Check the resistance* of retarder solenoid <p>* See page 3-52</p>
9E	<p>O.C. at retarder solenoid TCU detected a wrong voltage at the output pin, that looks like a O.C. for this output pin</p> <ul style="list-style-type: none"> • Cable is defective and has no connection to TCU • Retarder solenoid has an internal defect • Connector has no connection to TCU 	<p>No reaction OP mode : Normal</p>	<ul style="list-style-type: none"> • Check the cable from TCU to the retarder solenoid • Check the connectors from retarder solenoid to TCU • Check the resistance* of retarder solenoid <p>* See page 3-52</p>
9F	<p>S.C. to battery voltage at retarder solenoid TCU detected a wrong voltage at the output pin, that looks like a S.C. to battery voltage</p> <ul style="list-style-type: none"> • Cable is defective and has no connection to battery voltage • Retarder solenoid has an internal defect • Connector pin is contacted to battery voltage 	<p>No reaction OP mode : Normal</p>	<ul style="list-style-type: none"> • Check the cable from TCU to the retarder solenoid • Check the connectors from retarder solenoid to TCU • Check the resistance* of retarder solenoid <p>* See page 3-52</p>

Fault code (Hex)	Meaning of the fault code possible reason for fault detection	Reaction of the TCU	Possible steps to repair
A1	<p>S.C. to ground at difflock or axle connection solenoid</p> <p>TCU detected a wrong voltage at the output pin, that looks like a S.C. to vehicle ground</p> <ul style="list-style-type: none"> • Cable is defective and is contacted to vehicle ground • Difflock solenoid has an internal defect • Connector pin is contacted to vehicle ground 	No reaction OP mode : Normal	<ul style="list-style-type: none"> • Check the cable from TCU to the difflock solenoid • Check the connectors from difflock solenoid to TCU • Check the resistance* of difflock solenoid <p>* See page 3-52</p>
A2	<p>S.C. to battery voltage at difflock or axle connection solenoid</p> <p>TCU detected a wrong voltage at the output pin, that looks like a S.C. to battery voltage</p> <ul style="list-style-type: none"> • Cable is defective and has no connection to battery voltage • Difflock solenoid has an internal defect • Connector pin is contacted to battery voltage 	No reaction OP mode : Normal	<ul style="list-style-type: none"> • Check the cable from TCU to the difflock solenoid • Check the connectors from difflock solenoid to TCU • Check the resistance* of difflock solenoid <p>* See page 3-52</p>
A3	<p>O.C. at difflock or axle connection solenoid</p> <p>TCU detected a wrong voltage at the output pin, that looks like a O.C. for this output pin</p> <ul style="list-style-type: none"> • Cable is defective and has no connection to TCU • Difflock solenoid has an internal defect • Connector has no connection to TCU 	No reaction OP mode : Normal	<ul style="list-style-type: none"> • Check the cable from TCU to the difflock solenoid • Check the connectors from difflock solenoid to TCU • Check the resistance* of difflock solenoid <p>* See page 3-52</p>
A4	<p>S.C. to ground at warning signal output</p> <p>TCU detected a wrong voltage at the output pin, that looks like a S.C. to vehicle ground</p> <ul style="list-style-type: none"> • Cable is defective and is contacted to vehicle ground • Warning device has an internal defect • Connector pin is contacted to vehicle ground 	No reaction OP mode : Normal	<ul style="list-style-type: none"> • Check the cable from TCU to the warning device • Check the connectors from warning device to TCU • Check the resistance* of warning device <p>* See page 3-52</p>
A5	<p>O.C. voltage at warning signal output</p> <p>TCU detected a wrong voltage at the output pin, that looks like a O.C. for this output pin</p> <ul style="list-style-type: none"> • Cable is defective and has no connection to TCU • Warning device has an internal defect • Connector has no connection to TCU 	No reaction OP mode : Normal	<ul style="list-style-type: none"> • Check the cable from TCU to the warning device • Check the connectors from warning device to TCU • Check the resistance* of warning device <p>* See page 3-52</p>
A6	<p>S.C. to battery voltage at warning signal output</p> <p>TCU detected a wrong voltage at the output pin, that looks like a S.C. to battery voltage</p> <ul style="list-style-type: none"> • Cable is defective and has is contacted to battery voltage • Warning device has an internal defect • Connector pin is contacted to battery voltage 	No reaction OP mode : Normal	<ul style="list-style-type: none"> • Check the cable from TCU to the warning device • Check the connectors from warning device to TCU • Check the resistance* of warning device <p>* See page 3-52</p>

Fault code (Hex)	Meaning of the fault code possible reason for fault detection	Reaction of the TCU	Possible steps to repair
B1	<p>Slippage at clutch K1 TCU calculates a differential speed at closed clutch K1. If this calculated value is out of range, TCU interprets this as slipping clutch</p> <ul style="list-style-type: none"> • Low pressure at clutch K1 • Low main pressure • Wrong signal at internal speed sensor • Wrong signal at output speed sensor • Wrong size of the sensor gap • Clutch is defective 	<p>TCU shifts to neutral OP mode : Limp home If failure at another clutch is pending TCU shifts to neutral OP mode : TCU shutdown</p>	<ul style="list-style-type: none"> • Check pressure at clutch K1 • Check main pressure in the system • Check sensor gap at internal speed sensor • Check sensor gap at output speed sensor • Check signal at internal speed sensor • Check signal at output speed sensor • Replace clutch
B2	<p>Slippage at clutch K2 TCU calculates a differential speed at closed clutch K2. If this calculated value is out of range, TCU interprets this as slipping clutch</p> <ul style="list-style-type: none"> • Low pressure at clutch K2 • Low main pressure • Wrong signal at internal speed sensor • Wrong signal at output speed sensor • Wrong size of the sensor gap • Clutch is defective 	<p>TCU shifts to neutral OP mode : Limp home If failure at another clutch is pending TCU shifts to neutral OP mode : TCU shutdown</p>	<ul style="list-style-type: none"> • Check pressure at clutch K2 • Check main pressure in the system • Check sensor gap at internal speed sensor • Check sensor gap at output speed sensor • Check signal at internal speed sensor • Check signal at output speed sensor • Replace clutch
B3	<p>Slippage at clutch K3 TCU calculates a differential speed at closed clutch K3. If this calculated value is out of range, TCU interprets this as slipping clutch</p> <ul style="list-style-type: none"> • Low pressure at clutch K3 • Low main pressure • Wrong signal at internal speed sensor • Wrong signal at output speed sensor • Wrong size of the sensor gap • Clutch is defective 	<p>TCU shifts to neutral OP mode : Limp home If failure at another clutch is pending TCU shifts to neutral OP mode : TCU shutdown</p>	<ul style="list-style-type: none"> • Check pressure at clutch K3 • Check main pressure in the system • Check sensor gap at internal speed sensor • Check sensor gap at output speed sensor • Check signal at internal speed sensor • Check signal at output speed sensor • Replace clutch
B4	<p>Slippage at clutch K4 TCU calculates a differential speed at closed clutch K4. If this calculated value is out of range, TCU interprets this as slipping clutch</p> <ul style="list-style-type: none"> • Low pressure at clutch K4 • Low main pressure • Wrong signal at internal speed sensor • Wrong signal at turbine speed sensor • Wrong size of the sensor gap • Clutch is defective 	<p>TCU shifts to neutral OP mode : Limp home If failure at another clutch is pending TCU shifts to neutral OP mode : TCU shutdown</p>	<ul style="list-style-type: none"> • Check pressure at clutch K4 • Check main pressure in the system • Check sensor gap at internal speed sensor • Check sensor gap at turbine speed sensor • Check signal at internal speed sensor • Check signal at turbine speed sensor • Replace clutch

Fault code (Hex)	Meaning of the fault code possible reason for fault detection	Reaction of the TCU	Possible steps to repair
B5	<p>Slippage at clutch KV TCU calculates a differential speed at closed clutch KV. If this calculated value is out of range, TCU interprets this as slipping clutch</p> <ul style="list-style-type: none"> • Low pressure at clutch KV • Low main pressure • Wrong signal at internal speed sensor • Wrong signal at turbine speed sensor • Wrong size of the sensor gap • Clutch is defective 	<p>TCU shifts to neutral OP mode : Limp home If failure at another clutch is pending TCU shifts to neutral OP mode : TCU shutdown</p>	<ul style="list-style-type: none"> • Check pressure at clutch KV • Check main pressure in the system • Check sensor gap at internal speed sensor • Check sensor gap at turbine speed sensor • Check signal at internal speed sensor • Check signal at turbine speed sensor • Replace clutch
B6	<p>Slippage at clutch KR TCU calculates a differential speed at closed clutch KR. If this calculated value is out of range, TCU interprets this as slipping clutch</p> <ul style="list-style-type: none"> • Low pressure at clutch KR • Low main pressure • Wrong signal at internal speed sensor • Wrong signal at turbine speed sensor • Wrong size of the sensor gap • Clutch is defective 	<p>TCU shifts to neutral OP mode : Limp home If failure at another clutch is pending TCU shifts to neutral OP mode : TCU shutdown</p>	<ul style="list-style-type: none"> • Check pressure at clutch KR • Check main pressure in the system • Check sensor gap at internal speed sensor • Check sensor gap at turbine speed sensor • Check signal at internal speed sensor • Check signal at turbine speed sensor • Replace clutch
B7	<p>Overtemp sump TCU measured a temperature in the oil sump that is over the allowed threshold.</p>	<p>No reaction OP mode : Normal</p>	<ul style="list-style-type: none"> • Cool down machine • Check oil level • Check temperature sensor
B8	<p>Overtemp retarder TCU measured a temperature in the retarder oil that is over the allowed threshold</p>	<p>TCU disables retarder OP mode : Normal</p>	<ul style="list-style-type: none"> • Cool down machine • Check oil level • Check temperature sensor
B9	<p>Overspend engine</p>	<p>Retarder applies OP mode : Normal</p>	-
BA	<p>Differential pressure oil filter TCU measured a voltage at differential pressure switch out of the allowed range</p> <ul style="list-style-type: none"> • Oil filter is polluted • Cable/connector is broken or cable/connector is contacted to battery voltage or vehicle ground • Differential pressure switch is defective 	<p>No reaction OP mode : Normal</p>	<ul style="list-style-type: none"> • Check oil filter • Check wiring from TCU to differential pressure switch • Check differential pressure switch(Measure resistance)

Fault code (Hex)	Meaning of the fault code possible reason for fault detection	Reaction of the TCU	Possible steps to repair
BB	<p>Slippage at converter lockup clutch TCU calculates a differential speed at closed converter lockup clutch. If this calculated value is out of range, TCU interprets this as slipping clutch</p> <ul style="list-style-type: none"> • Low pressure at converter lockup clutch • Low main pressure • Wrong signal at engine speed sensor • Wrong signal at turbine speed sensor • Wrong size of the sensor gap • Clutch is defective 		<ul style="list-style-type: none"> • Check pressure at converter lockup clutch • Check main pressure in the system • Check sensor gap at engine speed sensor • Check sensor gap at turbine speed sensor • Check signal at engine speed sensor • Check signal at turbine speed sensor • Replace clutch
BD	<p>S.C. to ground at engine brake solenoid TCU detected a wrong voltage at the output pin, that looks like a S.C. to vehicle ground</p> <ul style="list-style-type: none"> • Cable is defective and is contacted to vehicle ground • Engine brake solenoid has an internal defect • Connector pin is contacted to vehicle ground 	No reaction OP mode : Normal	<ul style="list-style-type: none"> • Check the cable from TCU to engine brake solenoid • Check the connectors from engine brake solenoid to TCU • Check the resistance* of engine brake solenoid * See page 3-52
BE	<p>S.C. to battery voltage at engine brake TCU detected a wrong voltage at the output pin, that looks like a S.C. to battery voltage</p> <ul style="list-style-type: none"> • Cable is defective and is contacted to battery voltage • Engine brake solenoid has an internal defect • Connector pin is contacted to battery voltage 	No reaction OP mode : Normal	<ul style="list-style-type: none"> • Check the cable from TCU to the engine brake solenoid • Check the connectors from engine brake solenoid to TCU • Check the resistance* of engine brake solenoid * See page 3-52
BF	<p>O.C. at engine brake TCU detected a wrong voltage at the output pin, that looks like a O.C. for this output pin</p> <ul style="list-style-type: none"> • Cable is defective and has no connection to TCU • Engine brake solenoid has an internal defect • Connector has no connection to TCU 	No reaction OP mode : Normal	<ul style="list-style-type: none"> • Check the cable from TCU to the engine brake solenoid • Check the connectors from engine brake solenoid to TCU • Check the resistance* of engine brake solenoid * See page 3-52

Fault code (Hex)	Meaning of the fault code possible reason for fault detection	Reaction of the TCU	Possible steps to repair
C3	<p>Overtemp converter output TCU measured a oil temperature at the converter output that is the allowed threshold</p>	<p>No reaction OP mode : Normal</p>	<ul style="list-style-type: none"> • Cool down machine • Check oil level • Check temperature sensor
C4	<p>S.C. to ground at joystick status indicator TCU detected a wrong voltage at the output pin, that looks like a S.C. to vehicle ground</p> <ul style="list-style-type: none"> • Cable is defective and is contacted to vehicle ground • Joystick status indicator has an internal defect • Connector pin is contacted to vehicle ground 	<p>No reaction OP mode : Normal</p>	<ul style="list-style-type: none"> • Check the cable from TCU to joystick status indicator • Check the connectors from joystick status indicator to TCU • Check the resistance* of joystick status indicator * See page 3-52
C5	<p>S.C. to battery voltage at joystick status indicator TCU detected a wrong voltage at the output pin, that looks like a S.C. to battery voltage</p> <ul style="list-style-type: none"> • Cable is defective and is contacted to battery voltage • Joystick status indicator has an internal defect • Connector pin is contacted to battery voltage 	<p>No reaction OP mode : Normal</p>	<ul style="list-style-type: none"> • Check the cable from TCU to joystick status indicator • Check the connectors from joystick status indicator to TCU • Check the resistance* of joystick status indicator * See page 3-52
C6	<p>O.C. at joystick status indicator TCU detected a wrong voltage at the output pin, that looks like a O.C. for this output pin</p> <ul style="list-style-type: none"> • Cable is defective and has no connection to TCU • Joystick status indicator has an internal defect • Connector pin has no connection to TCU 	<p>No reaction OP mode : Normal</p>	<ul style="list-style-type: none"> • Check the cable from TCU to joystick status indicator • Check the connectors from joystick status indicator to TCU • Check the resistance* of joystick status indicator * See page 3-52

Fault code (Hex)	Meaning of the fault code possible reason for fault detection	Reaction of the TCU	Possible steps to repair
D1	S.C. to battery voltage at power supply for sensors TCU measures more than 6V at the pin AU1 (5V sensor supply)	See fault codes No.21 to 2C	<ul style="list-style-type: none"> • Check cables and connectors to sensors, which are supplied from AU1 • Check the power supply at the pin AU1(Should be appx. 5V) ※ Fault codes No.21 to No.2C may be reaction of this fault
D2	S.C. to ground at power supply for sensors TCU measures less than 4V at the pin AU1 (5V sensor supply)	See fault codes No.21 to 2C	<ul style="list-style-type: none"> • Check cables and connectors to sensors, which are supplied from AU1 • Check the power supply at the pin AU1(Should be appx. 5V) ※ Fault codes No.21 to No.2C may be reaction of this fault
D3	Low voltage at battery Measured voltage at power supply is lower than 18V(24V device)	Shift to neutral OP mode : TCU shutdown	<ul style="list-style-type: none"> • Check power supply battery • Check cables from batteries to TCU • Check connectors from batteries to TCU
D4	High voltage at battery Measured voltage at power supply is higher than 32.5V(24V device)	Shift to neutral OP mode : TCU shutdown	<ul style="list-style-type: none"> • Check power supply battery • Check cables from batteries to TCU • Check connectors from batteries to TCU
D5	Error at valve power supply VPS1 TCU switched on VPS1 and measured VPS1 is off or TCU switched off VPS1 and measured VPS1 is still on <ul style="list-style-type: none"> • Cable or connectors are defect and are contacted to battery voltage • Cable or connectors are defect and are contacted to vehicle ground • Permanent power supply KL30 missing • TCU has an internal defect 	Shift to neutral OP mode : TCU shutdown	<ul style="list-style-type: none"> • Check fuse • Check cables from gearbox to TCU • Check connectors from gearbox to TCU • Replace TCU
D6	Error at valve power supply VPS2 TCU switched on VPS2 and measured VPS2 is off or TCU switched off VPS2 and measured VPS2 is still on <ul style="list-style-type: none"> • Cable or connectors are defect and are contacted to battery voltage • Cable or connectors are defect and are contacted to vehicle ground • Permanent power supply KL30 missing • TCU has an internal defect 	Shift to neutral OP mode : TCU shutdown	<ul style="list-style-type: none"> • Check fuse • Check cables from gearbox to TCU • Check connectors from gearbox to TCU • Replace TCU

Fault code (Hex)	Meaning of the fault code possible reason for fault detection	Reaction of the TCU	Possible steps to repair
E1	S.C. battery voltage at speedometer output	-	※ Not used
E2	S.C. to ground or O.C at speedometer output	-	※ Not used
E3	S.C. to battery voltage at display output TCU sends data to the display and measures always a high voltage level on the connector <ul style="list-style-type: none"> • Cable or connectors are defective and are contacted to battery voltage • Display has an internal defect 	No reaction OP mode : Normal	<ul style="list-style-type: none"> • Check the cable from TCU to the display • Check the connectors at the display • Change display
E4	S.C. to ground at display output TCU sends data to the display and measures always a high voltage level on the connector <ul style="list-style-type: none"> • Cable or connectors are defective and are contacted to battery voltage • Display has an internal defect 	No reaction OP mode : Normal	<ul style="list-style-type: none"> • Check the cable from TCU to the display • Check the connectors at the display • Change display
E5	Communication failure on DeviceNet	Shift to neutral OP mode : TCU shutdown	<ul style="list-style-type: none"> • Check Omron master • Check wire of DeviceNet-Bus • Check cable to Omron master
E5	DISPID1 timeout Timeout of CAN-massage DISPID1 from display controller <ul style="list-style-type: none"> • Interference on CAN-Bus • CAN wire/connector is defective • Can wire/connector is defective and has contact to vehicle ground or battery voltage 	TCU select parameter set with ID0 OP mode : Limp home	<ul style="list-style-type: none"> • Check display controller • Check wire of CAN-Bus • Check cable display controller

Fault code (Hex)	Meaning of the fault code possible reason for fault detection	Reaction of the TCU	Possible steps to repair
F1	General EEPROM fault TCU can't read non volatile memory · TCU is defective	No reaction OP mode : Normal	· Replace TCU ※ Often shown together with fault code F2
F2	Configuration lost TCU has lost the correct configuration and can't control the transmission · Interference during saving data on non volatile memory · TCU is brand new or from another vehicle	Transmission stay neutral OP mode : TCU shutdown	· Reprogram the correct configuration for the vehicle (e.g. with cluster controller,...)
F3	Application error Something of this application is wrong	Transmission stay neutral OP mode : TCU shutdown	· Replace TCU ※ This fault occurs only if an test engineer did something wrong in the application of the vehicle
F5	Clutch failure AEB was not able to adjust clutch filling parameters · One of the AEB-Values is out of limit	Transmission stay neutral OP mode : TCU shutdown	· Check clutch ※ TCU shows also the affected clutch on the display
F6	Clutch adjustment data lost TCU was not able to read correct clutch adjustment parameters · Interference during saving data on non volatile memory · TCU is brand new	No reaction, Default values : 0 for AEB Offsets used OP mode : Normal	· Execute AEB

(9) Measuring of resistance at actuator/sensor and cable

① Actuator

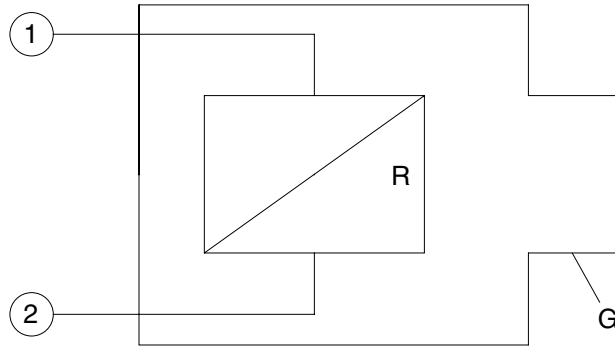

76043PT19

Open circuit	$R_{12} = R_{1G} = R_{2G} = \infty$
Short cut to ground	$R_{12} = R$; $R_{1G} = 0, R_{2G} = R$ or $R_{1G} = R, R_{2G} = 0$ (For S.C. to ground, G is connected to vehicle ground)
Short cut to battery	$R_{12} = R$; $R_{1G} = 0, R_{2G} = R$ or $R_{1G} = R, R_{2G} = 0$ (For S.C. to battery, G is connected to battery voltage)

② Cable

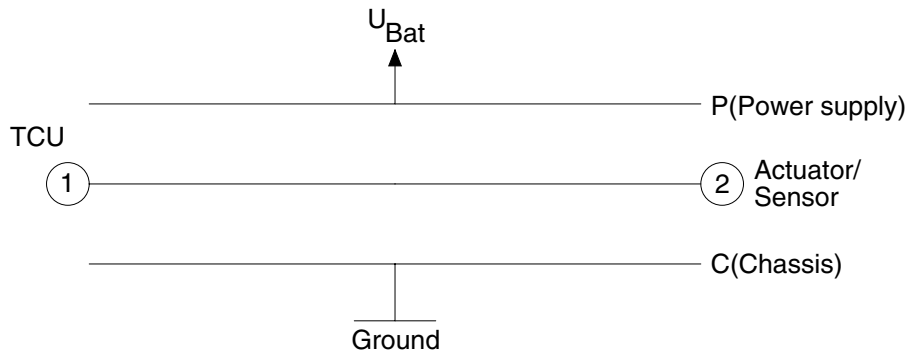

76043PT20

Open circuit	$R_{12} = R_{1P} = R_{1C} = R_{2P} = R_{2C} = \infty$
Short cut to ground	$R_{12} = 0$; $R_{1C} = R_{2C} = 0, R_{1P} = R_{2P} = \infty$
Short cut to battery	$R_{12} = 0$; $R_{1C} = R_{2C} = 0, R_{1P} = R_{2P} = 0$

7) ELECTRIC CONTROL UNIT

(1) Complete system

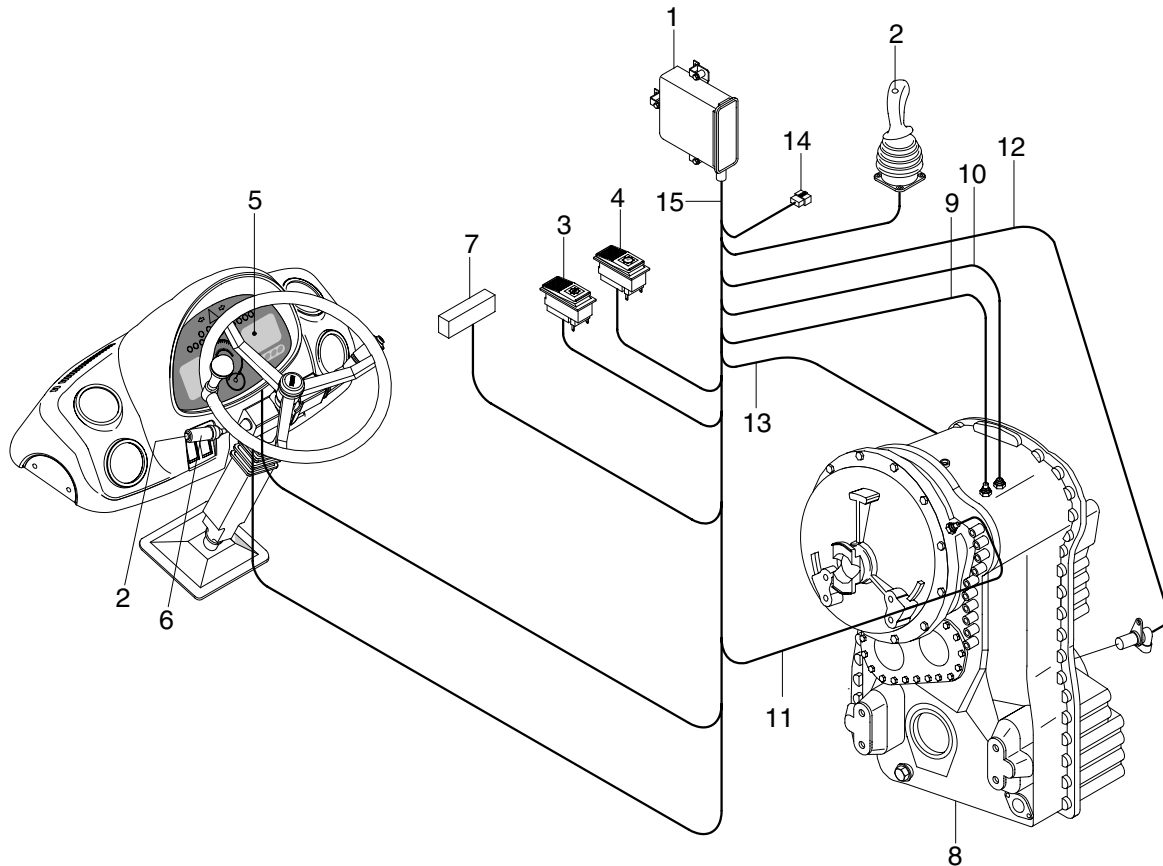

7407APT11

- 1 Transmission control unit(EST-37A)
- 2 Kickdown switch
- 3 Clutch cut off switch
- 4 Full automatic switch
- 5 LCD
- 6 Gear selector(DW-3) with integrated kickdown switch
- 7 Power supply connection
- 8 Transmission
- 9 Cable to inductive transmitter - speed central gear train
- 10 Cable to inductive transmitter - speed turbine
- 11 Cable to inductive transmitter - speed engine
- 12 Cable to speed sensor output and speedometer
- 13 Cable to plug connection on the electro - hydraulic control unit
- 14 CAN-Connection
- 15 Wiring

(2) Description of the basic functions

The powershift transmissions is equipped is electronic transmission control unit(EST-37A), developed for it.

The system is processing the desire of the driver according to the following criteria.

- Gear determination depending on controller position, driving speed and load condition.

- Protection from operating errors as far as necessary, is possible via electronic protection (programming).
- Protection from over-speeds(On the basis of engine and turbine speed).
- Automatic reversing(Driving speed-dependent).
- Pressure cut-off possible(Disconnecting of the drive train for maximum power on the power take-off).
- Change-over possibility for Auto-/Manual mode.
- Kick down functions possible.

(3) Driving and shifting

- Neutral position :

Neutral position will be selected via the controller.

After the ignition is switched on, the electronics remains in the waiting state. By the position NEUTRAL of the controller, resp. by pressing the pushbutton NEUTRAL, the EST-37A becomes ready for operation.

Now, a gear can be engaged.

- Starting :

The starting of the engine has always to be carried out in the NEUTRAL POSITION of the controller.

For safety reasons it is to recommend to brake the machine securely in position with the parking brake prior to start the engine.

After the starting of the engine and the preselection of the driving direction and the gear, the machine can be set in motion by acceleration.

At the start off, the converter takes over the function of a master clutch.

On a level road it is possible to start off also in higher gears.

- Upshifting under load

Upshifting under load will be then realized if the machine can still accelerate by it.

- Downshifting under load

Downshifting under load will be realized if more traction force is needed.

- Upshifting in overrunning condition

In the overrunning mode, the upshifting will be suppressed by accelerator pedal idling position, if the speed of the machine on a downgrade should not be further increased.

- Downshifting in overrunning condition

Downshiftings in overrunning mode will be then carried out if the machine should be retarded.

If the machine will be stopped and is standing with running engine and engaged transmission, the engine cannot be stalled. On a level and horizontal roadway it is possible that the machine begins to crawl, because the engine is creating at idling speed a slight drag torque via the converter.

It is convenient to brake the machine at every stop securely in position with the parking brake.

At longer stops, the controller has to be shifted to the NEUTRAL POSITION.

At the start off, the parking brake has to be released. We know from experience that at a converter transmission it might not immediately be noted to have forgotten this quite normal operating step because a converter, due to its high ratio, can easily overcome the braking torque of the parking brake.

Temperature increases in the converter oil as well as overheated brakes will be the consequences to be find out later.

Neutral position of the selector switch at higher machine speeds(above stepping speed) is not admissible.

Either a suitable gear is to be shifted immediately, or the machine must be stopped at once.

(4) Independent calibration of the shifting elements(AEB)

The AEB has the task to compensate tolerances(plate clearance and pressure level) which are influencing the filling procedure of the clutches. For each clutch, the correct filling parameters are determined in one test cycle for :

- Period of the quick-filling time
- Level of the filling compensating pressure

The filling parameters are stored, together with the AEB-program and the driving program in the transmission electronics. Because the electronics will be separately supplied, the AEB-cycle must be started only after the installation of both components in the machine, thus ensuring the correct mating(Transmission and electronics).

※ It is imperative, to respect the following test conditions :

- Shifting position neutral
- Engine in idling speed
- Parking brake actuated
- Transmission in operating temperature

※ After a replacement of the transmission, the electrohydraulic control or the TCU in the machine, the AEB-cycle must be as well carried out again.

The AEB-cycle continues for about 3 to 4 minutes. The determined filling parameters are stored in the EEPROM of the electronics. In this way, the error message F6 shown on the display will be cancelled also at non-performed AEB.

(5) Pressure cut-off

In order to provide the full engine power for the hydraulic system, the control can be enlarged for the function of a pressure cut-off in the 1st and 2nd speed. In this way, the pressure in the powershift clutches will be cut-off, and the torque transmission in the drive train will be eliminated by it. This function will be released at the actuation of a switch, arranged on the brake pedal.

For a soft restart, the pressure will be build-up via a freely programmable characteristic line.

2) SECTION OF FRONT AXLE DIFFERENTIAL(LIMITED SLIP)

(1) Structure

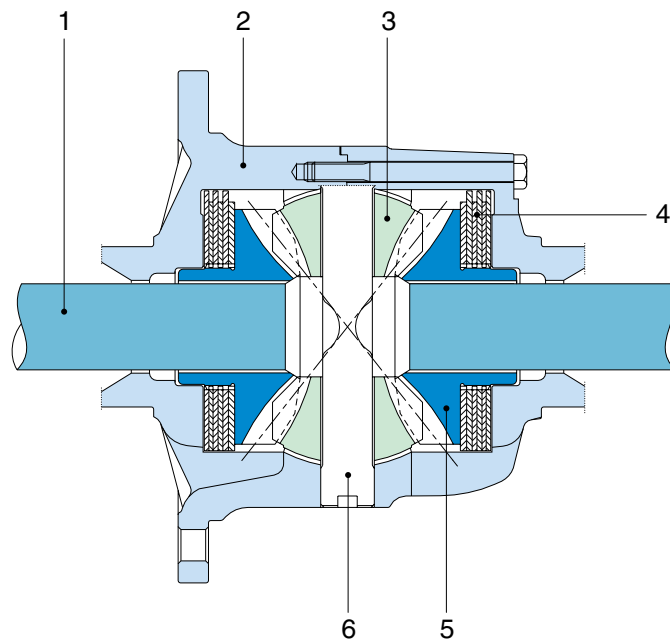

7803ASPT15

- | | | | |
|---|-------------|---|--------------|
| 1 | Axle shaft | 4 | Clutch |
| 2 | Case | 5 | Side gear |
| 3 | Pinion gear | 6 | Pinion shaft |

2) Operation

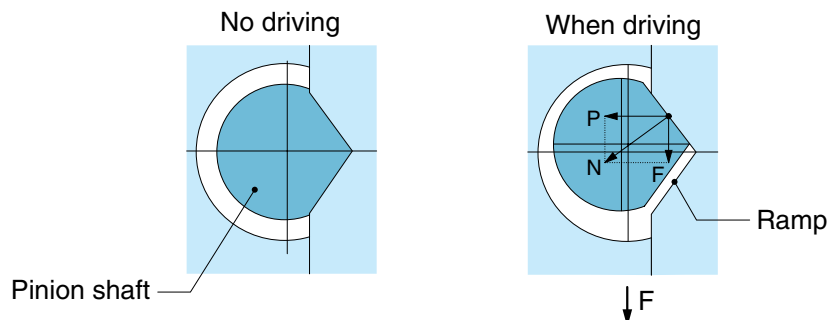

7803ASPT16

When the differential case is rotated, pinion shaft is moved up on the ramp by the resistance force of tires as the figure, and then force P is generated. This force P becomes the engaging force of clutch.

- ① When travelling straight(equal resistance from road surface to left and right tires). Under this condition, both clutches are engaged and the left and right side gears are driven with the same force.
- ② When travelling on soft ground(Resistance from road surface to right tire is smaller). At rotating speed of right tire becomes faster than left due to the smaller resistance of right tire, right clutch is engaged and torque of faster rotating right axle shaft is added to left axle shaft through differentiating gear case.

3) SECTION OF REAR AXLE DIFFERENTIAL(CONVENTIONAL)

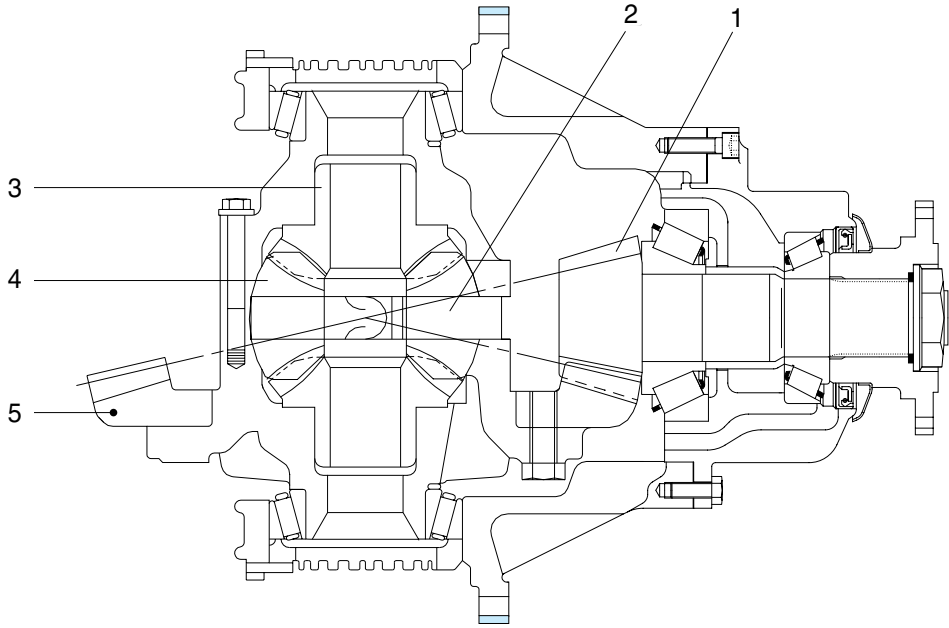

76043PT19

- | | | | | | |
|---|--------------|---|-------------------------|---|------------|
| 1 | Bevel pinion | 3 | Side gear(Differential) | 5 | Bevel gear |
| 2 | Shaft | 4 | Sun gear | | |

4) DIFFERENTIAL

(1) Description

When the machine makes a turn, the outside wheel must rotate faster than the inside wheel. A differential is a device which continuously transmits power to the right and left wheels while allowing them to turn a different speeds, during a turn.

The power from the drive shaft passes through bevel pinion(1) and is transmitted to the bevel gear(2). The bevel gear changes the direction of the motive force by 90 degree, and at the same time reduces the speed.

It then transmits the motive force through the differential(3) to the axle gear shaft(4).

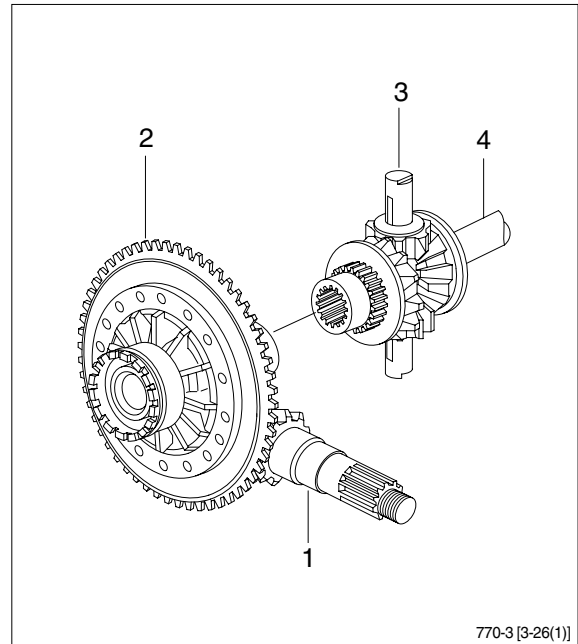

(2) When driving straight forward

When the machine is being driven straight forward and the right and left wheels are rotating at the same speed, so the pinion gear inside the differential assembly do not rotate. The motive force of the carrier is send through the pinion gear and the side gear, therefore the power is equally transmitted to the left and right axle gear shaft.

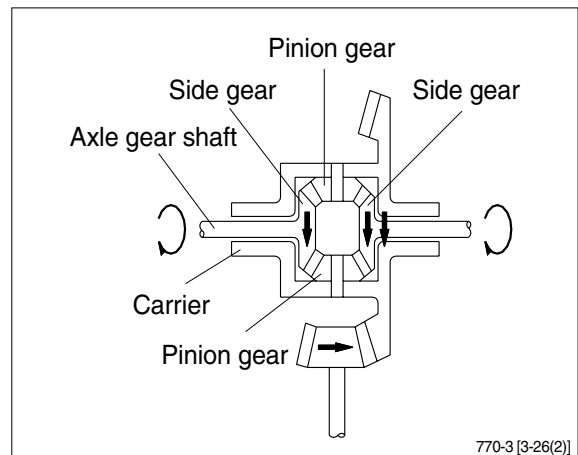

(3) When turning

When turning, the rotating speed of the left and right wheels is different, so the pinion gear and side gear inside the differential assembly rotate in accordance with the difference between the rotating speed of the left and right wheels.

The power of the carrier is then transmitted to the axle gear shafts.

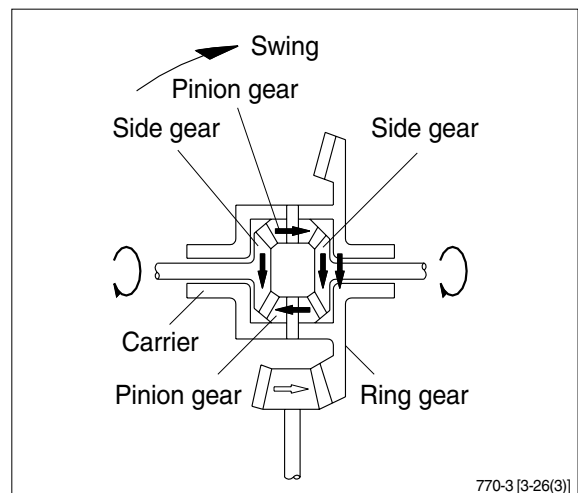

5) TORQUE PROPORTIONING DIFFERENTIAL

(1) Function

- ① Because of the nature of their work, 4-wheel-drive loaders have to work in places where the road surface is bad. In such places, if the tires slip, the ability to work as a loader is reduced, and also the life of the tire is reduced. The torque proportioning differential is installed to overcome this problem. In structure it resembles the differential of an automobile, but the differential pinion gear has an odd number of teeth. Because of the difference in the resistance from the road surface, the position of meshing of the pinion gear and side gear changes, and this changes the traction of the left and right tires.

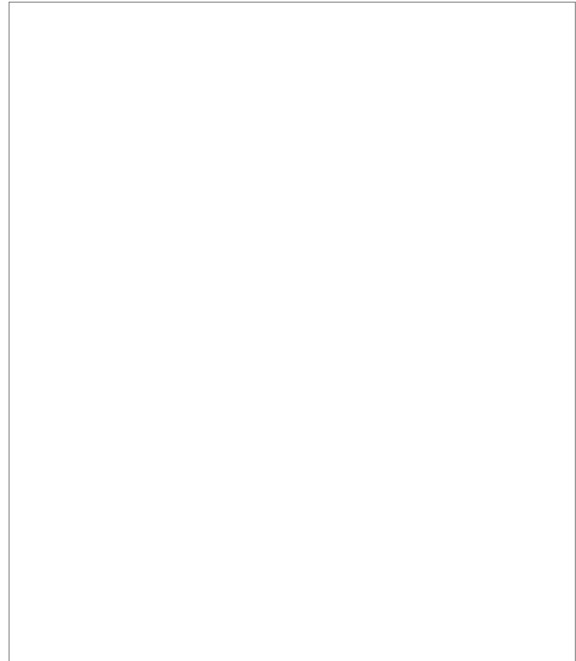

(2) Operation

- ① **When traveling straight**(Equal resistance from road surface to left and right tires)
Under this condition, the distances involving the engaging points between right and left side gears and pinion-a and b-are equal and the pinion is balanced as $FL \times a = FR \times b$. Thus, $FL = FR$, and the right and left side gears are driven with the same force.

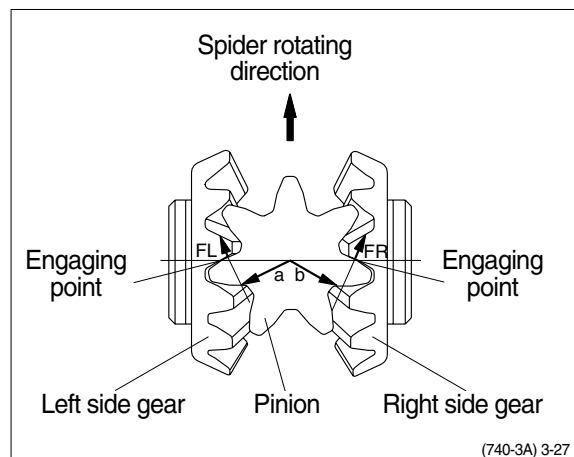

② **When traveling on soft ground**
(Resistance from road surface to left and right tires is different)

If the road resistance to the left wheel is smaller, the left side gear tends to rotate forward, and this rotation changes the engaging points between the side gears and pinion. As a result, the distances involving the engaging points becomes $a > b$. The pinion now is balanced as $FL \times a = FR \times b$, where $FL > FR$. The right side gear is driven with a greater force than the left side gear. The torque can be increased by up to about 30% for either side gear.

The pinion therefore does not run idle and driving power is transmitted to both side gears until the difference between road resistance to the right and left wheels reaches about 30%.

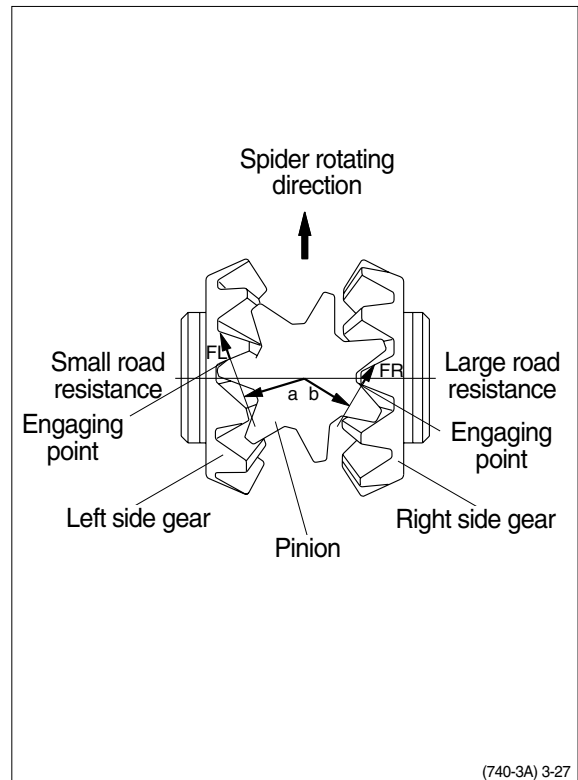

6) FINAL DRIVE(Front & rear)

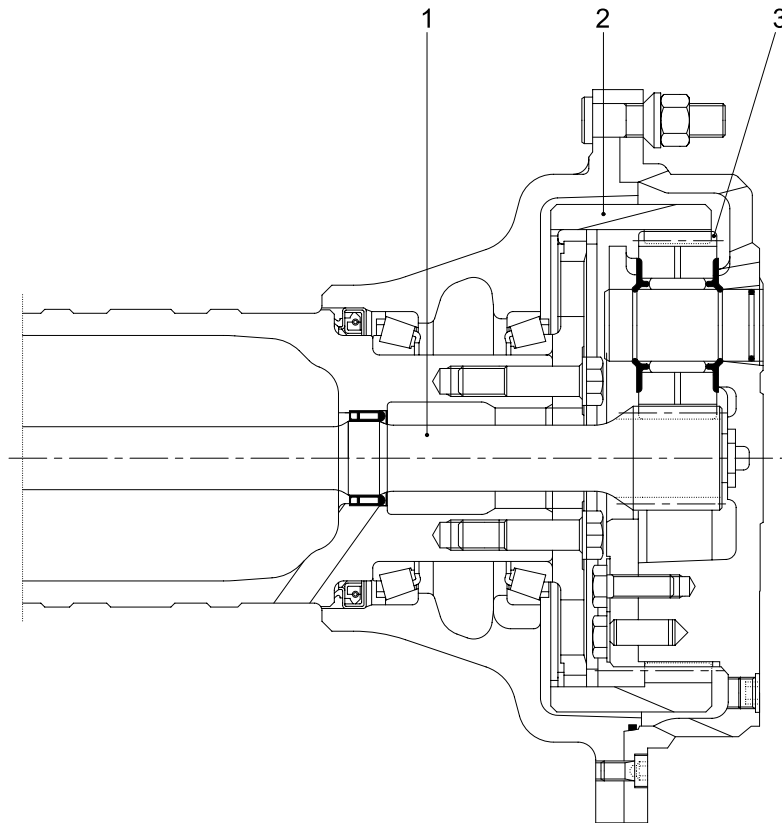

7403APT03

1 Axle shaft

2 Ring gear

3 Planetary gear

(1) To gain a large drive force, the final drive uses a planetary gear system to reduce the speed and send drive force to the tires.

(2) The power transmitted from the differential through axle shaft(1) is transmitted to planetary gear(2). The planetary gear rotates around the inside of a fixed ring gear(3) and in this way transmits rotation at a reduced speed to the planetary carrier.

This power is then sent to the wheels which are installed to the planetary carriers.

6. TIRE AND WHEEL

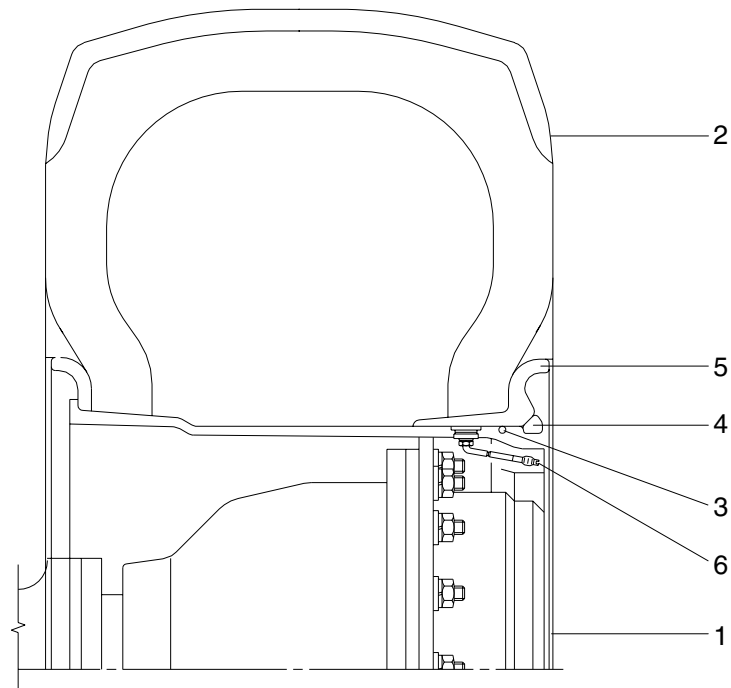

7407APT10

- | | | | | | |
|---|-----------|---|-----------|---|----------------|
| 1 | Wheel rim | 3 | O-ring | 5 | Side ring |
| 2 | Tire | 4 | Lock ring | 6 | Valve assembly |

- 1) The tire acts to absorb the shock from the ground surface to the machine, and at the same time they must rotate in contact with the ground to gain the power which drives the machine.
- 2) Various types of tires are available to suit the purpose. Therefore it is very important to select the correct tires for the type of work and bucket capacity.