

## SECTION 5 STEERING SYSTEM

Group 1	Structure and Function	5-1
Group 2	Operational Checks and Troubleshooting	5-14
Group 3	Tests and Adjustments	5-21
Group 4	Disassembly and Assembly	5-28

# SECTION 5 STEERING SYSTEM

## GROUP 1 STRUCTURE AND FUNCTION

### 1. OUTLINE

The steering system of this machine consists of a fixed-displacement pump supplying a load sensing steering system and an open center loader system.

The components of the steering system are :

- Steering pump(1st pump)
- Steering unit
- Overload valve block
- Priority valve
- Steering cylinders

The steering pump, the first pump of main pump, draws hydraulic oil from the hydraulic tank.

Outlet flow from the pump flows to the priority valve. The priority valve preferentially supplies flow, on demand, to the steering unit. When the machine is steered, the steering unit routes flow to the steering cylinders to articulate the machine.

When the machine is not being steered, or if pump flow is greater than steering flow, the priority valve supplies flow to the loader system.

That is, output flow from the steering pump enters into the first pump of main pump for the operation of the attachment.

## 2. HYDRAULIC CIRCUIT

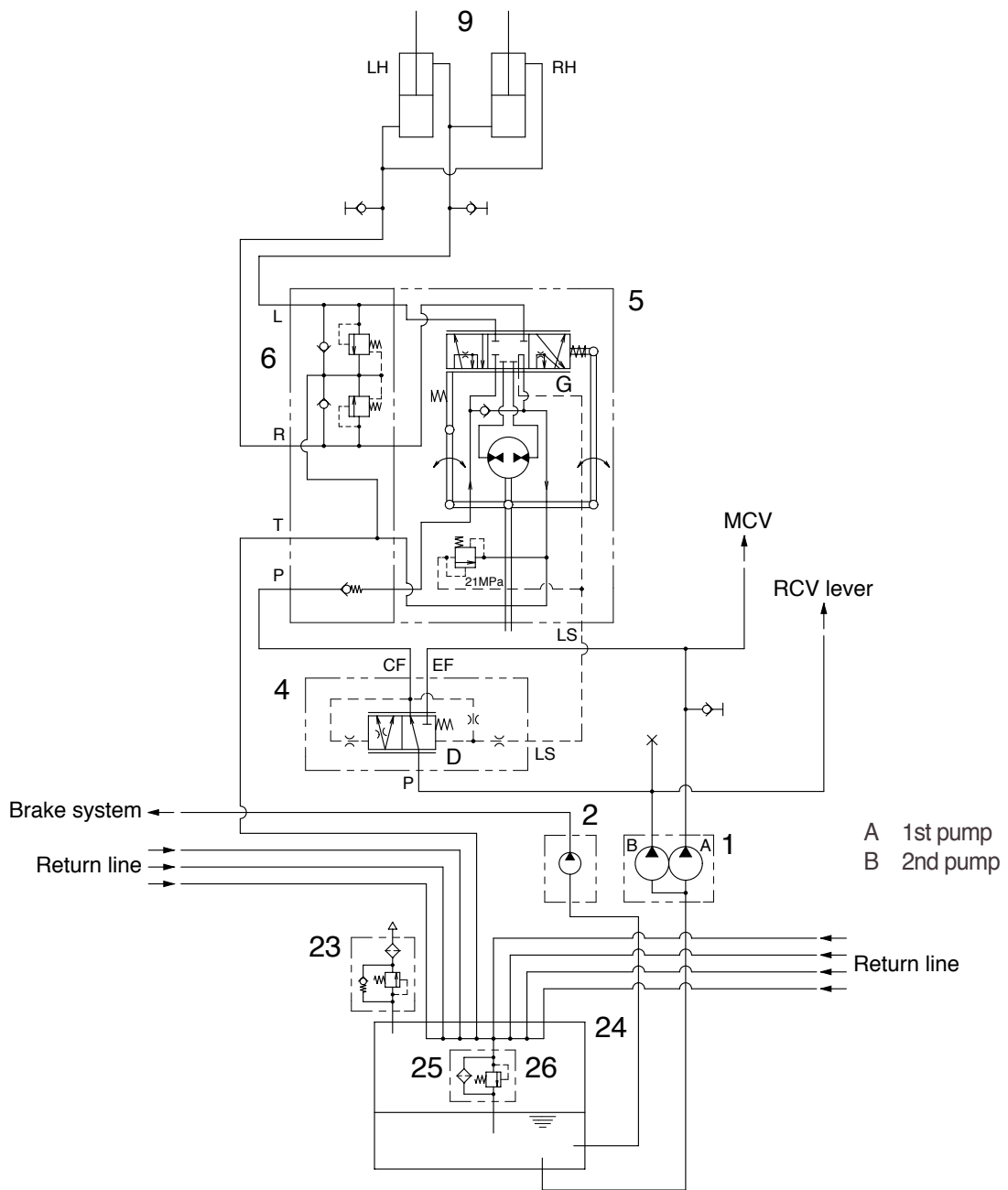

- |   |                |    |                      |    |                |
|---|----------------|----|----------------------|----|----------------|
| 1 | Main pump      | 6  | Overload valve block | 24 | Hydraulic tank |
| 2 | Brake pump     | 9  | Steering cylinder    | 25 | Return filter  |
| 4 | Priority valve | 23 | Air breather         | 26 | Bypass valve   |
| 5 | Steering unit  |    |                      |    |                |



## 2) LEFT TURN

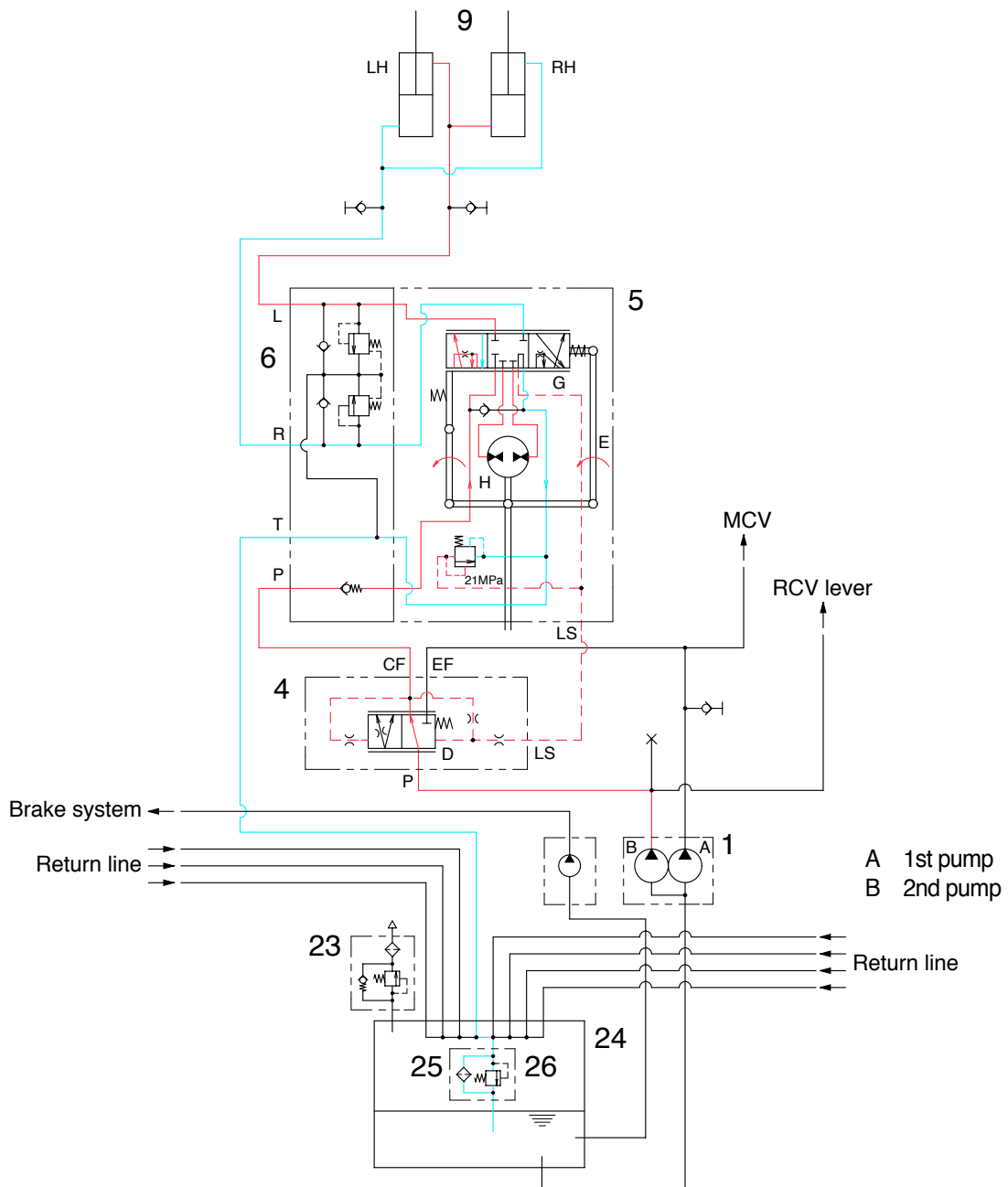

When the steering wheel(E) is turned to the left, the spool(G) within the steering unit(5) connected with steering column turns in left hand direction.

At this time, the oil discharged from the steering pump flows into the spool(G) of the steering unit(5) through the spool(D) of priority valve and flows into the gerotor(H).

Oil flow from the gerotor flows back into the spool(G) where it is directed out the left work port(L) to the respective chamber of the steering cylinders(9).

Oil returned from left and right cylinder returns to hydraulic tank through the spool of the steering unit.

When the above operation is completed, the machine turns to the left.

### 3) RIGHT TURN

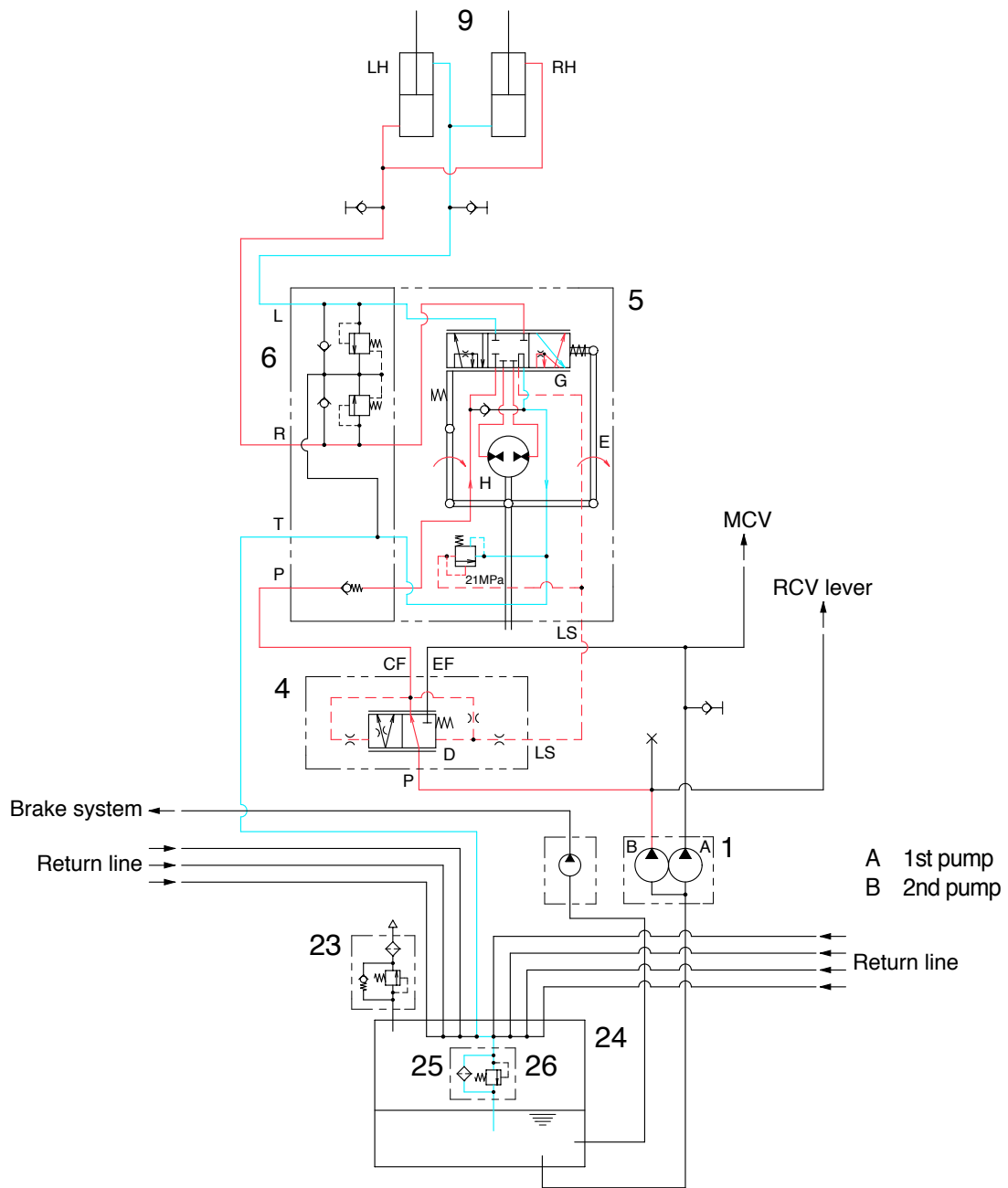

When the steering wheel(E) is turned to the right, the spool(G) within the steering unit(5) connected with steering column turns in right hand direction.

At this time, the oil discharged from the steering pump flows into the spool(G) of the steering unit(5) through the spool(D) of priority valve and flows into the gerotor(H).

Oil flow from the gerotor flows back into the spool(G) where it is directed out the right workport to the respective chamber of the steering cylinders(9).

Oil returned from left and right cylinder returns to hydraulic tank through the spool of the steering unit.

When the above operation is completed, the machine turns to the right.

### 3. PRIORITY VALVE

#### 1) STRUCTURE

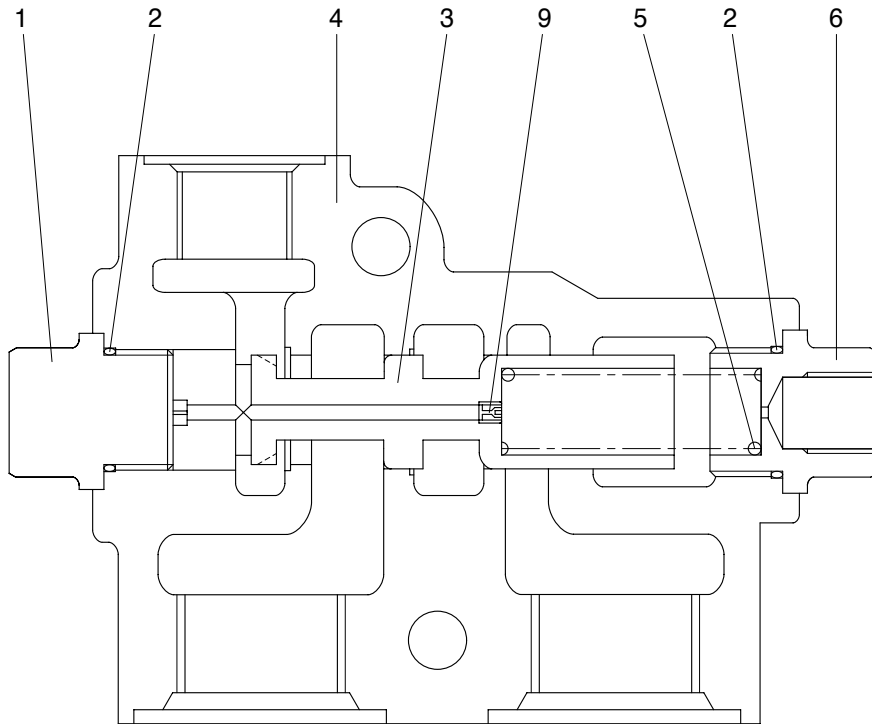

- 1 Plug
- 2 O-ring
- 3 Spool

- 4 Housing
- 5 Spring
- 6 Plug

- 8 Drive screw
- 9 Orifice

## 2) OPERATION

### (1) Neutral

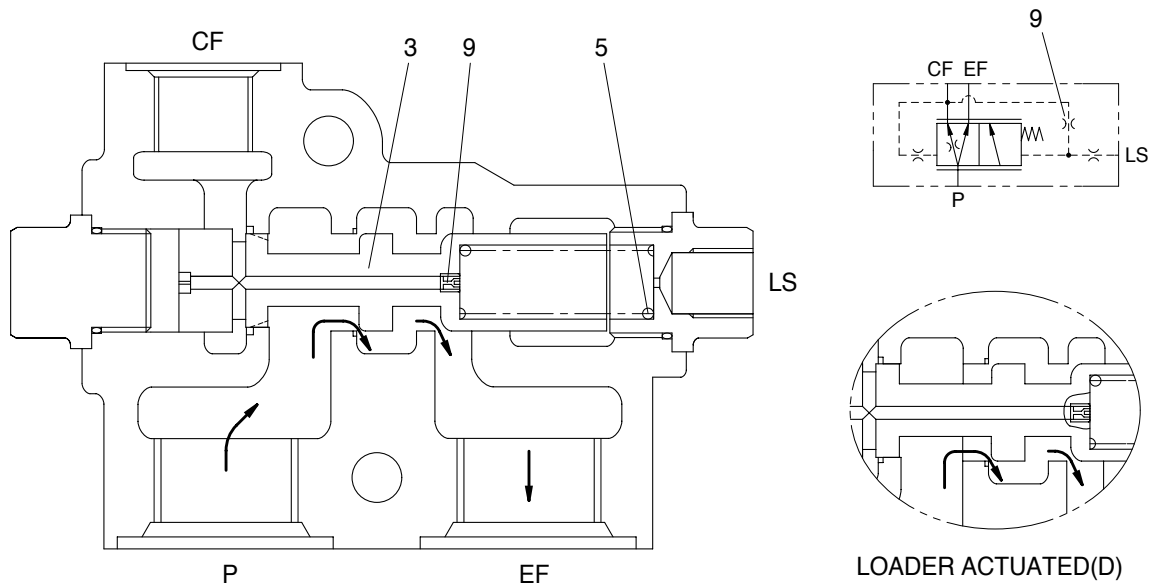

The priority valve is a pressure control valve that maintains priority pressure to the closed center steering valve. With the steering valve in neutral, flow through is blocked and all flow through the priority valve is directed out the EF port to the main control valve.

With the engine off, the spool(3) is pushed to the left(Viewed from sectional drawing at previous page) by the spring(5). The passage to the EF port is blocked while the passage to the CF port is open.

When the machine is first started, all pump flow is routed to the steering valve which blocks the flow. With the flow blocked, the pressure increases.

Steering inlet pressure is supplied through the pilot orifice to the left end of the spool. This causes the priority valve spool(3) to shift to the right against the spring and open the EF port.

As long as the steering valve is in neutral, just enough pressure is maintained at the steering valve to keep the priority valve spool shifted to the right.

The operating pressure in the loader system has no effect on the operation of the priority valve. With the loader actuated in relief(D) the priority valve will not shift until the machine is steered.

Flow through the priority valve spool passes from the CF port through the orifice(9) and into the LS port. It flows through the steering valve LS passage which is routed to return when the steering valve is in neutral. This provides a warm-up circuit for the steering valve to prevent binding of the steering valve due to oil temperature extremes.

## (2) Midturn

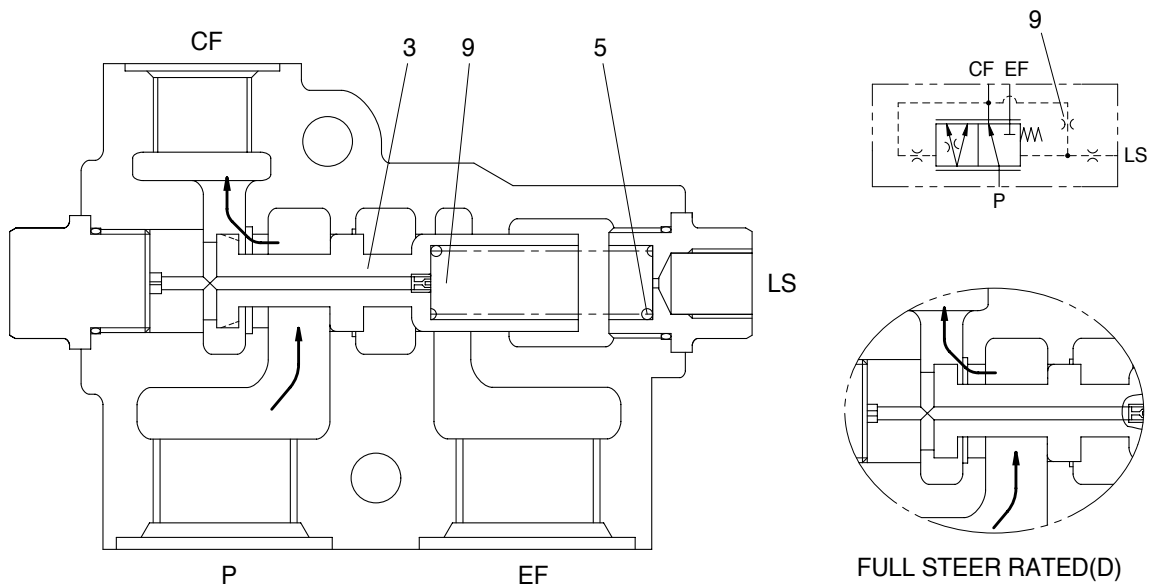

When the machine is steered, load sensing pressure from the steering valve flows through the orifices LS port in the priority valve. Load sensing pressure plus spring(5) force move the spool(3) to the right against the pilot pressure on the left end of the spool. This restricts flow to the loader through the EF port while the CF port is opened to the steering valve.

The load sensing circuit is a control circuit that routes steering workport pressure to the spring side of the priority valve spool. It allows the priority valve spool to sense the pressure that is required to steer the unit under varying conditions.

During normal steering conditions, oil is entered into the load sensing circuit through an orifice in the steering valve. When steering at the full steer rate(D), the orifice opens to an unrestricted passage. At low engine speed, the spool will shift to the full left position, directing all flow to the steering valve. At high idle, the steering system can use about one-half of the pump flow. Therefore, the excess oil flows to the main control valve.

The load-sensing circuit receives the majority of its flow from the load sensing orifice in the steering valve. Some flow is also supplied from the CF port through orifice(9) in the priority valve spool.

### (3) Full turn

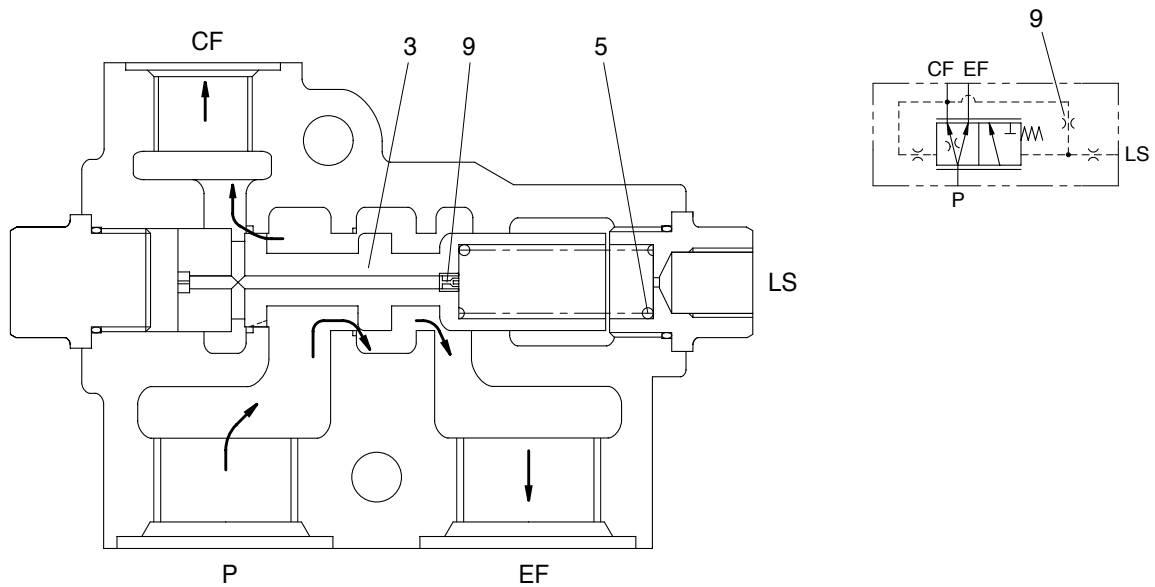

When the machine is steered to a full turn, the frames bottom against the steering stops.

Pressure to the steering valve (Pilot pressure), which is sensed at the left end of the priority valve spool (3), continues to increase until it can move the spool to the right against the load sensing pressure plus spring force. At this time, all oil flows out of the EF port to the loader control valve.

If the loader attachment is being operated while steering, the loader function will slow until the machine reaches the steering stops. At that time, the loader cycle speed will increase until the machine is steered again.

## 4. STEERING UNIT

### 1) STRUCTURE

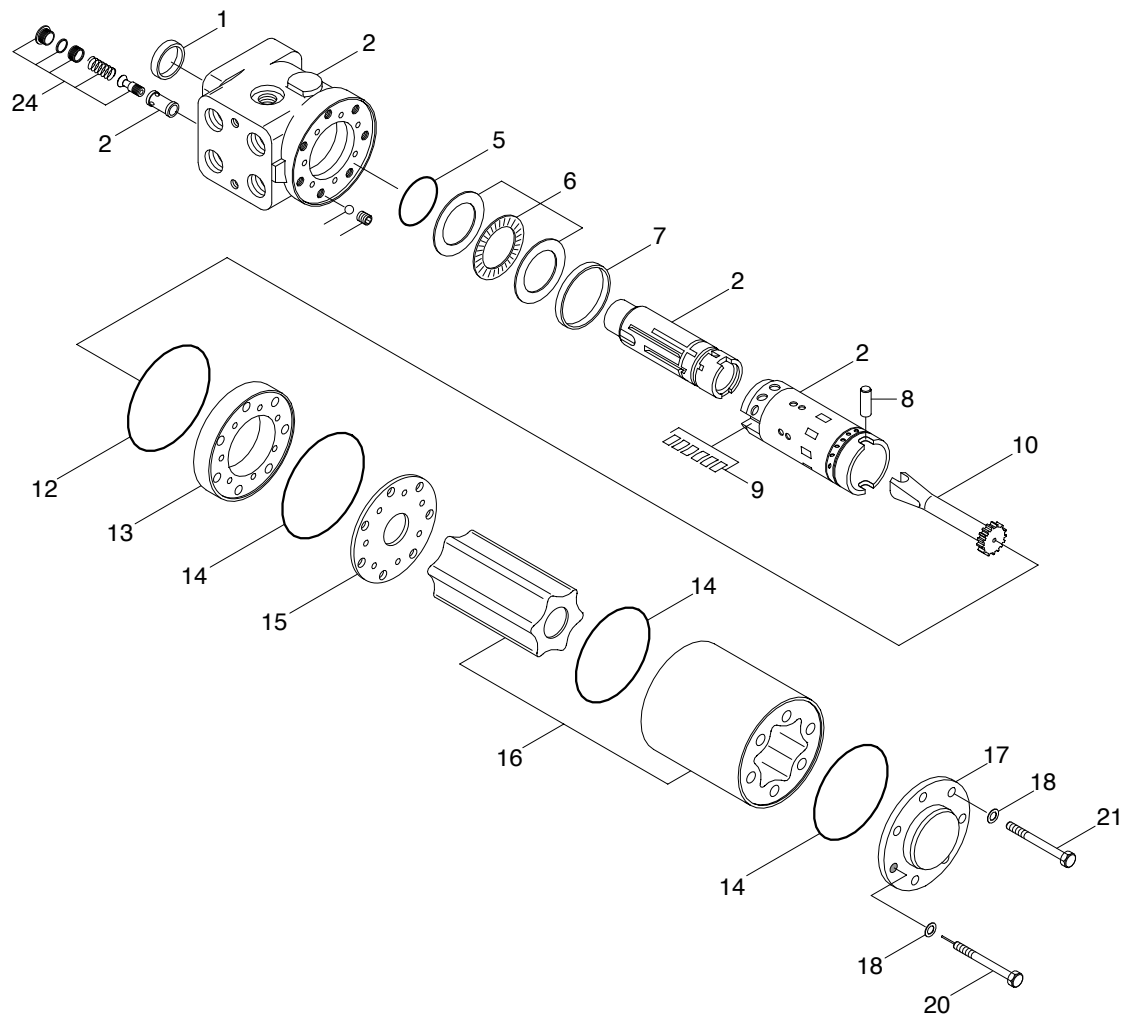

- |   |              |    |                    |    |                    |
|---|--------------|----|--------------------|----|--------------------|
| 1 | Dust seal    | 8  | Cross pin          | 16 | Gearwheel set      |
| 2 | Housing assy | 9  | Spring set         | 17 | End cover          |
| 3 | Ball         | 10 | Cardan shaft       | 18 | Washer             |
| 4 | Bushing      | 12 | O-ring             | 20 | Pin screw          |
| 5 | O-ring       | 13 | Intermediate plate | 21 | Screw              |
| 6 | Bearing assy | 14 | O-ring             | 24 | Pilot relief valve |
| 7 | Ring         | 15 | Distributor plate  |    |                    |

## 2) OPERATION

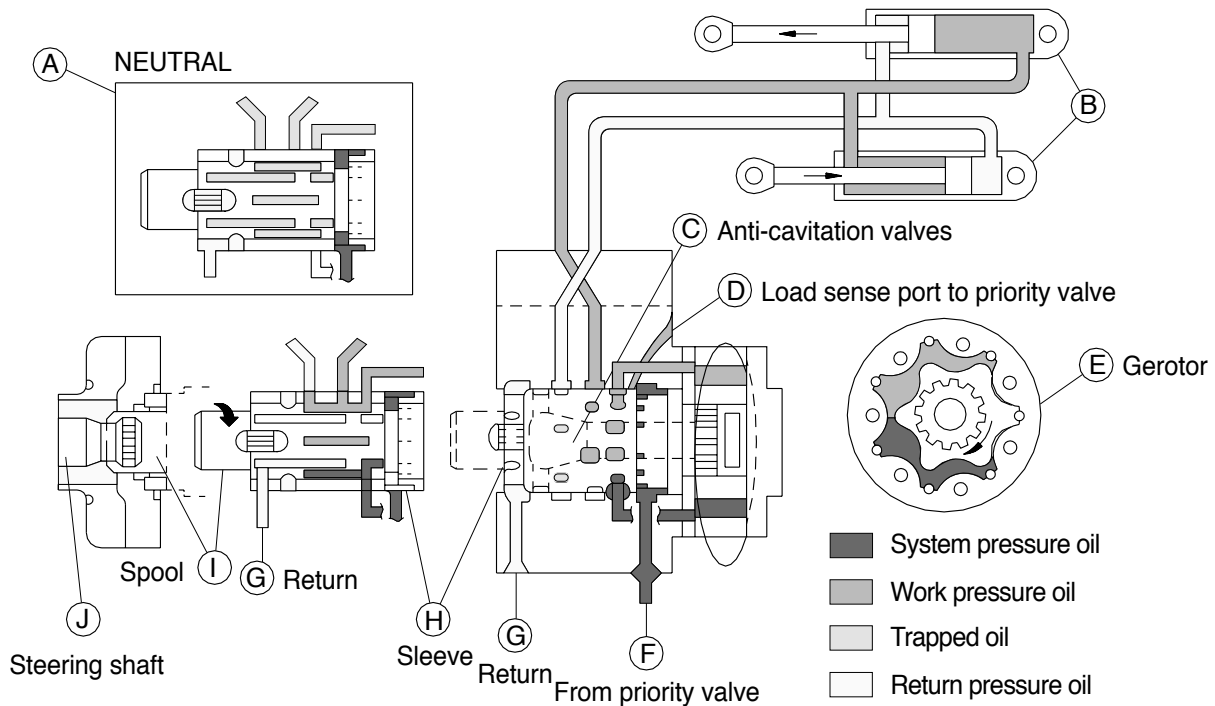

The steering valve consists of a spool(I) inside a sleeve(H) within a housing. When steering wheel is not moving, the valve is in the neutral(A) position. In neutral, the spool and sleeve are aligned so that oil flow through the valve is blocked. The steering cylinder(B) are held stationary by trapped oil in the left and right workports.

When the steering valve is turned to the right, the spool rotates relative to the sleeve, and opens passages which allow pump flow through the spool and sleeve assembly. Oil flows to the gerotor(E) causing the gerotor gear to rotate. Oil flow from the gerotor flows back into the valve where it is directed out the right workport to the respective ends of the steering cylinders.

A bypass orifice is machined into the spool and sleeve assembly. It is a variable orifice that introduces a small leak into the pressure side of the steering valve. Its purpose is to dampen the initial pressure surge when the steering wheel is partially turned. When the steering wheel is fully turned, the leak is closed off.

Return oil flows back in through the left workport through the spool and sleeve assembly to return. The load sensing orifice is located between the sleeve and the gerotor. This orifice feeds the load sensing circuit between the steering valve and the priority valve through the LS port.

When the rotation of the steering wheel stops, the gerotor gear continues to move, turning the sleeve, until the sleeve stops the flow to the gerotor. At this point, the valve is back in the neutral position and will remain there until the steering wheel is moved again.

The valve has a variable steering which is proportional to the speed the steering wheel is rotated. A variable orifice bypasses oil around the gerotor. Turning the steering wheel slowly takes approximately seven turn(Variable orifice small) lock to lock versus four turns(Variable orifice large) when turning the steering wheel quickly.

## 5. OVERLOAD VALVE

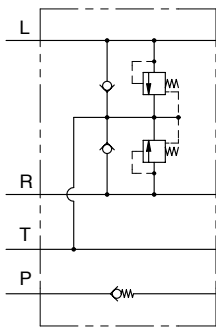
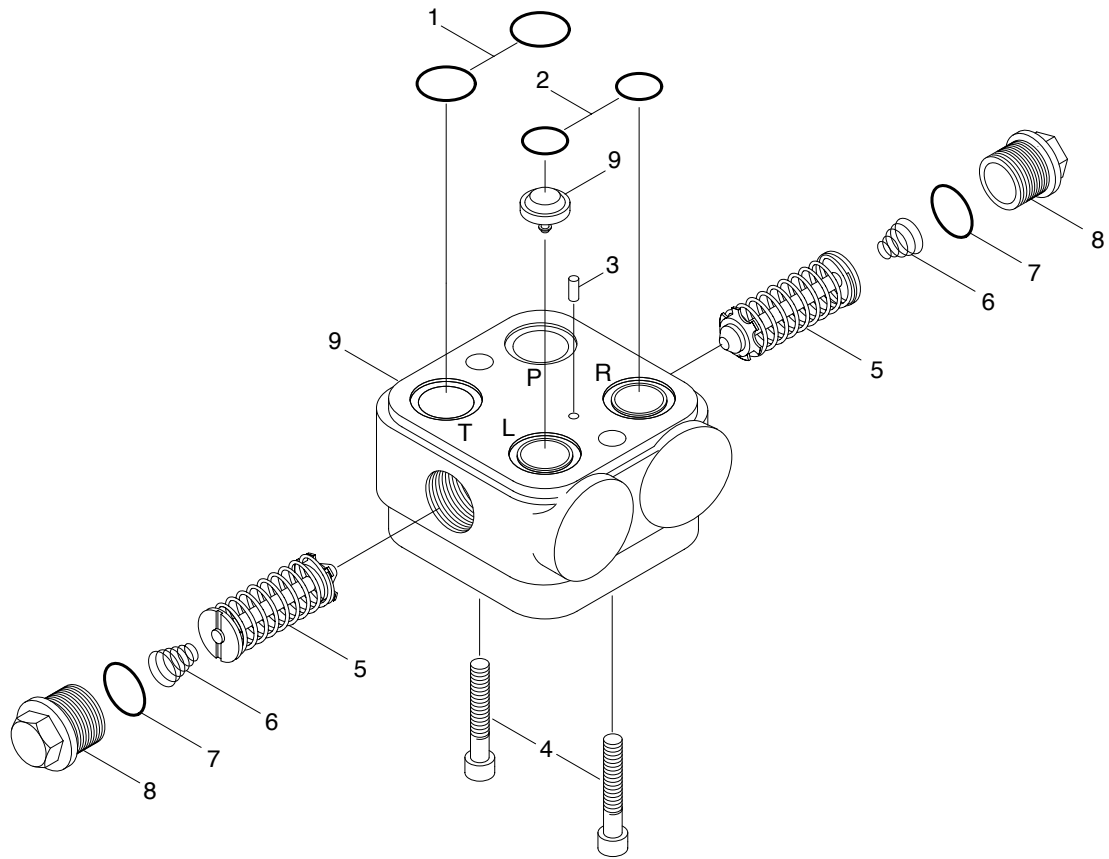

HYDRAULIC CIRCUIT

P, T, L, R port	3/4-16 UNF
Shock valves	270-290 bar
Screw	M10 x 1 x 46

- |   |             |   |             |   |                              |
|---|-------------|---|-------------|---|------------------------------|
| 1 | O-rings set | 4 | Screw       | 7 | O-ring                       |
| 2 | O-rings set | 5 | Shock valve | 8 | Plug                         |
| 3 | Rolled pin  | 6 | Spring      | 9 | Housing assy,<br>Cheek valve |

## 6. STEERING CYLINDER

### 1) STRUCTURE

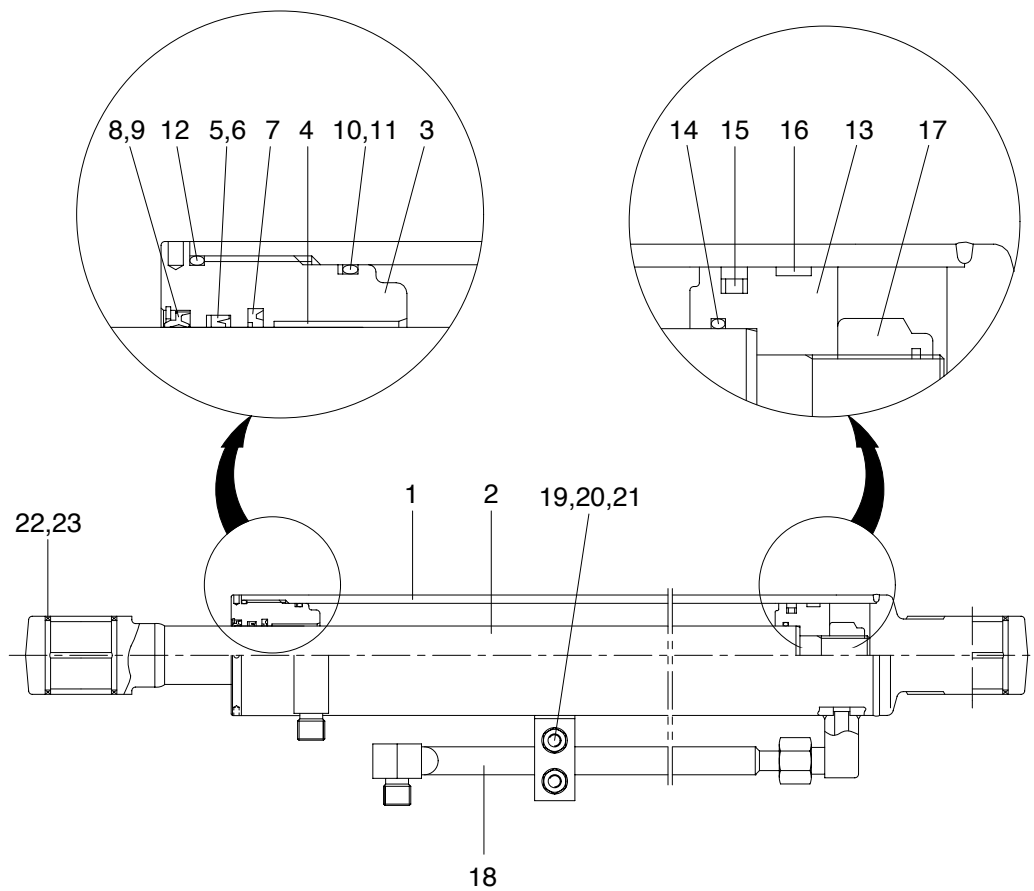

1	Tube assy	9	Snap ring	17	Nylon nut
2	Rod assy	10	O-ring	18	Pipe assy
3	Gland	11	Back up ring	19	U-bolt
4	Du bushing	12	O-ring	20	Hexagon nut
5	Rod seal	13	Piston	21	Spring washer
6	Back up ring	14	O-ring	22	Bushing
7	Buffer ring	15	Piston seal	23	Dust seal
8	Dust wiper	16	Wear ring		

### 2) OPERATION

This machine use to cross connected cylinder for steering operation.

The steering cylinder use a gland(3) to remove piston and sealed seals. Dust wiper(8) located on the in side of the gland protects cylinder inner parts from dust. The piston(13) is fastened to the rod(2) by a nut(17).

The piston uses a single wear ring(16) with a piston seal(15) to seal between the piston and tube. The gland seals against the tube with two O-rings. The rod is sealed against the gland with a rod seal(5).