

SECTION 4 BRAKE SYSTEM

Group 1	Structure and Function	4-1
Group 2	Operational Checks and Troubleshooting	4-23
Group 3	Tests and Adjustments	4-31
Group 4	Disassembly and Assembly	4-33

SECTION 4 BRAKE SYSTEM

GROUP 1 STRUCTURE AND FUNCTION

1. OUTLINE

The brakes are operated by a pressure compensated, closed center hydraulic system.

Flow is supplied by a fixed displacement, gear type brake pump.

BRAKE SYSTEM

The fixed displacement brake pump supplies flow to service brake circuit and park brake circuits. It flows to four accumulator. The accumulator has a gas precharge and an inlet check valve to maintain a pressurized volume of oil for reserve brake applications.

Oil through the accumulator flows to the brake valves. The brake valve is a closed center design, dual circuit operated by a pedal.

The front and rear brakes will operate simultaneously with only one brake pedal depressed.

The differential contains annular brake piston and double sided disk.

Brake pump flow also goes to the parking brake solenoid valve.

The brake system contains the following components:

- Brake pump
- Parking brake solenoid valve
- Brake valve
- Accumulators
- Pressure switches

FULL POWER HYDRAULIC BRAKE SYSTEM

ADVANTAGES - The full power hydraulic brake system has several advantages over traditional brake actuation systems. These systems are capable of supplying fluid to a range of very small and large volume service brakes with actuation that is faster than air brake systems. Figure represents a time comparison between a typical air/hydraulic and full power hydraulic brake actuation system.

Full power systems can supply significantly higher brake pressures with relatively low reactive pedal forces. The reactive pedal force felt by the operator will be proportional to the brake line pressure being generated. This is referred to as brake pressure modulation.

Another key design feature of full power systems is the ability to control maximum brake line pressure. In addition, because these systems operate with hydraulic oil, filtration can be utilized to provide long component life and low maintenance operation.

Because these systems are closed center, by using a properly sized accumulator, emergency power-off braking that is identical to power-on braking can be achieved. These systems can be either dedicated, where the brake system pump supplies only the demands of the brake system or non-dedicated, where the pump supplies the demands of the brake system as well as some secondary down stream hydraulic device.

Another important note is that all seals within these system must be compatible with the fluid medium being used.

**Response time
Full power brake actuation VS
Air/Hydraulic brake actuation**

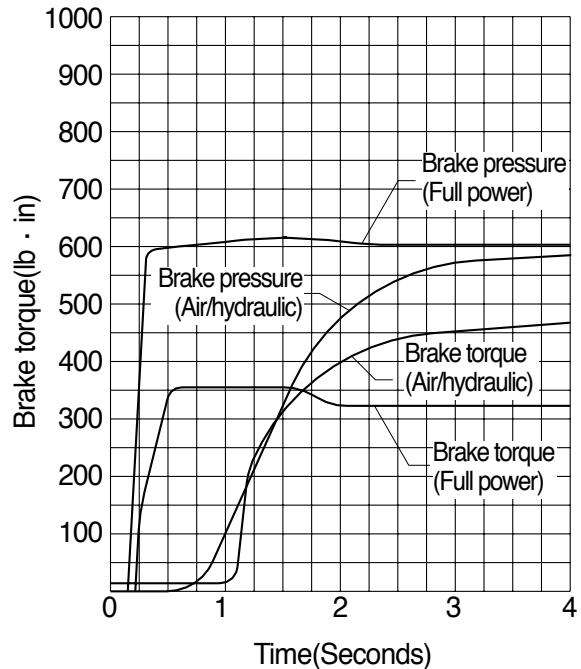

2. HYDRAULIC CIRCUIT

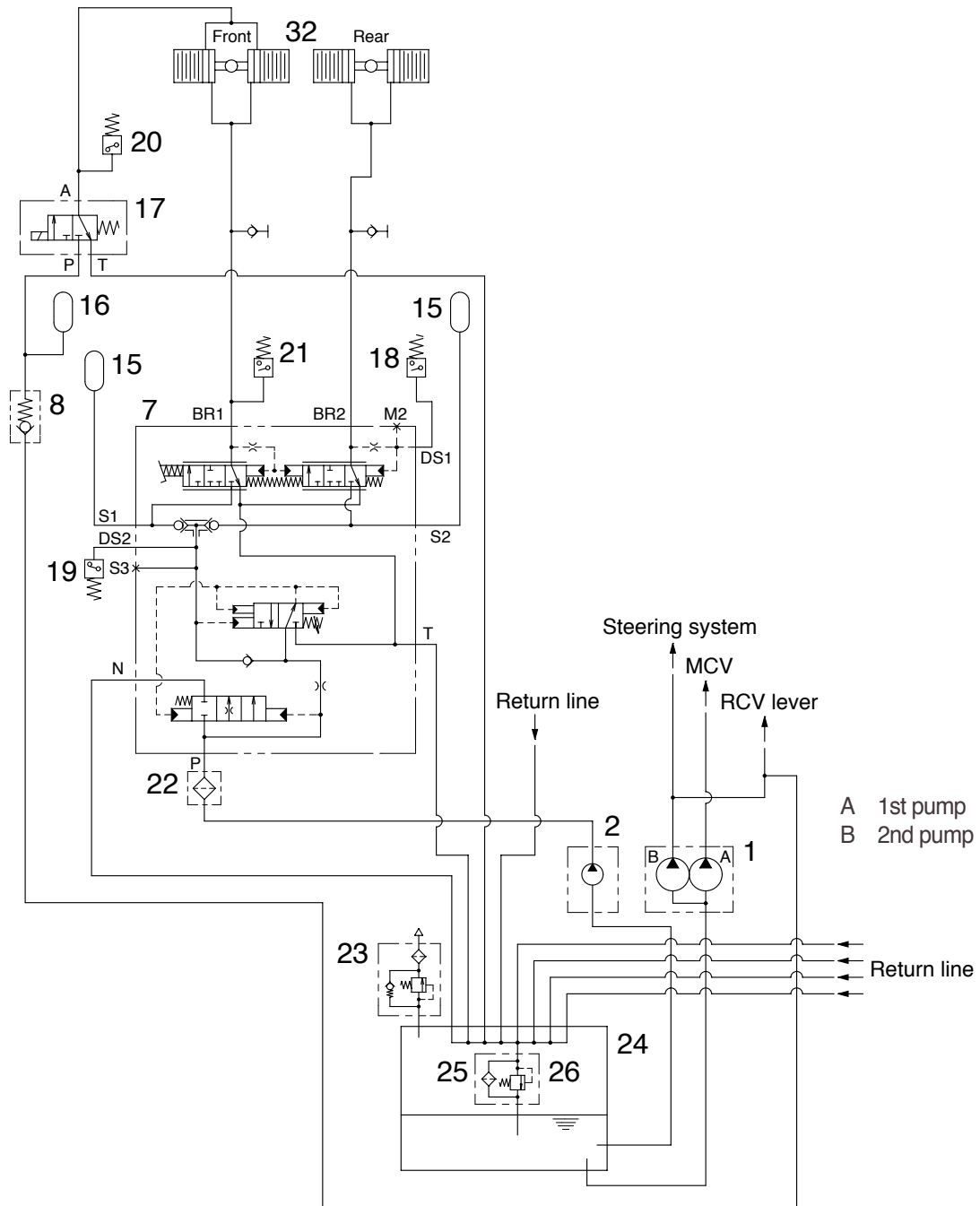

- | | | | | | |
|----|-------------|----|-----------------|----|----------------|
| 1 | Main pump | 17 | Solenoid valve | 23 | Air breather |
| 2 | Brake pump | 18 | Pressure switch | 24 | Hydraulic tank |
| 7 | Brake valve | 19 | Pressure switch | 25 | Return filter |
| 8 | Check valve | 20 | Pressure switch | 26 | Bypass valve |
| 15 | Accumulator | 21 | Pressure switch | 32 | Axle |
| 16 | Accumulator | 22 | Line filter | | |

1) SERVICE BRAKE RELEASED

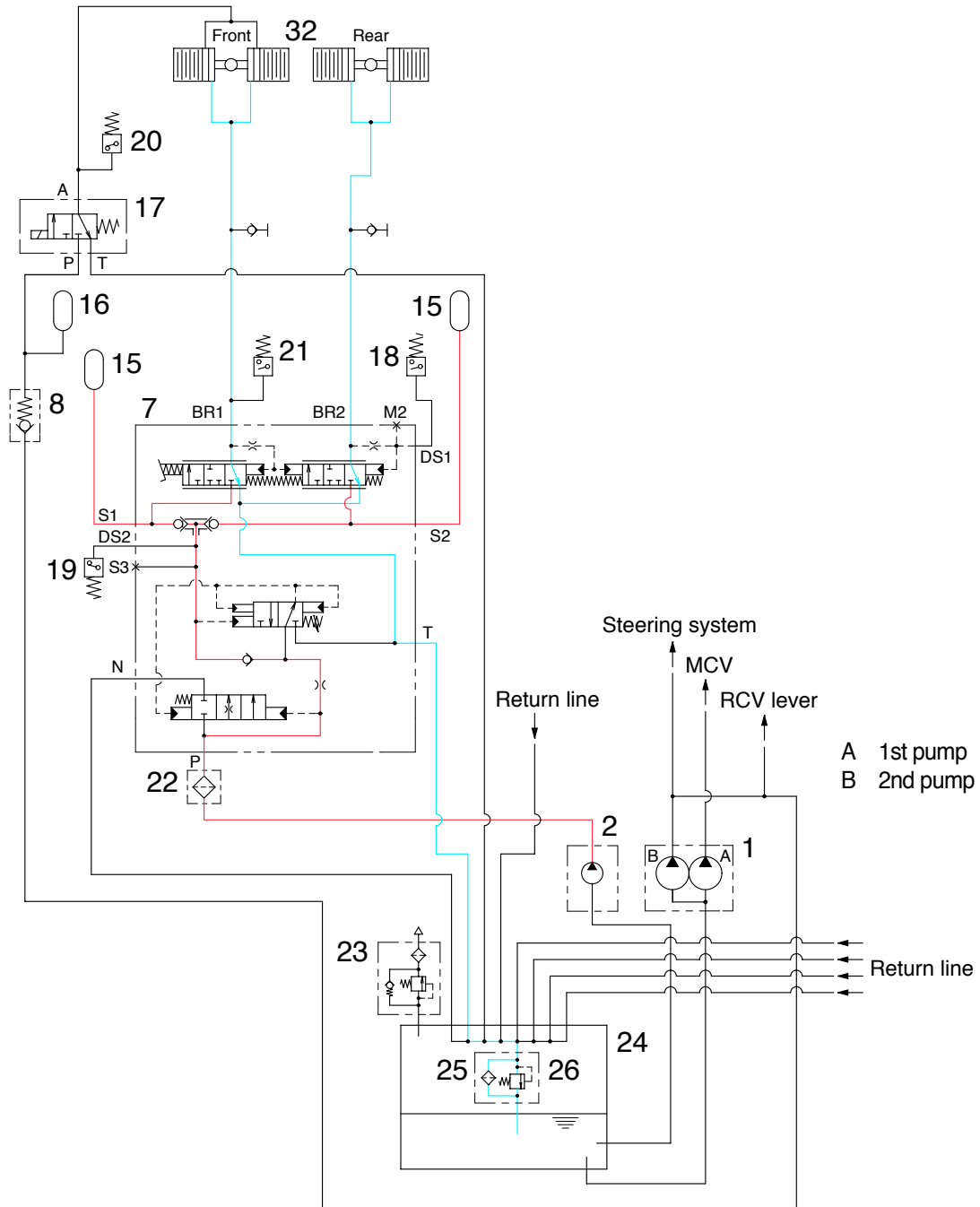

When the pedal of brake valve(7) is released, the operating force is eliminated by the force of the spring, and the spool is returned.

When the spool removes up, the exhaust port is opened and the hydraulic oil in the piston of axles (32) return to the tank(24).

Therefore, the service brake is kept released.

2) SERVICE BRAKE OPERATED

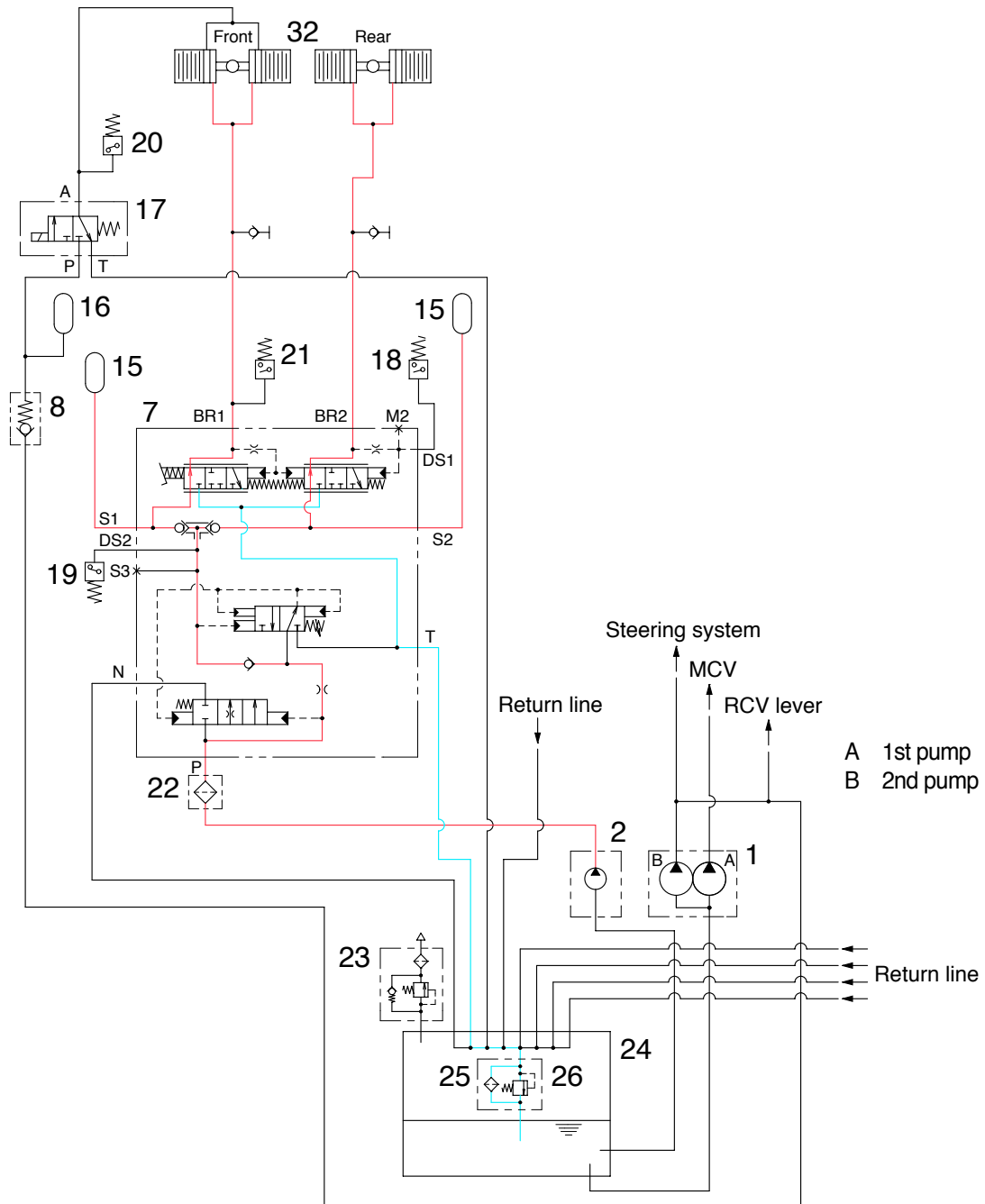

When the pedal of brake valve(7) is depressed, the operating force overcomes the force of the spring, and is transmitted to the spool. When the spool moves down, the inlet port is opened, and at the same time the hydraulic oil controlled the pressure level by the other spool in the brake valve enters the piston in the front and rear axles. Therefore, the service brake is applied.

3) PARKING BRAKE RELEASED

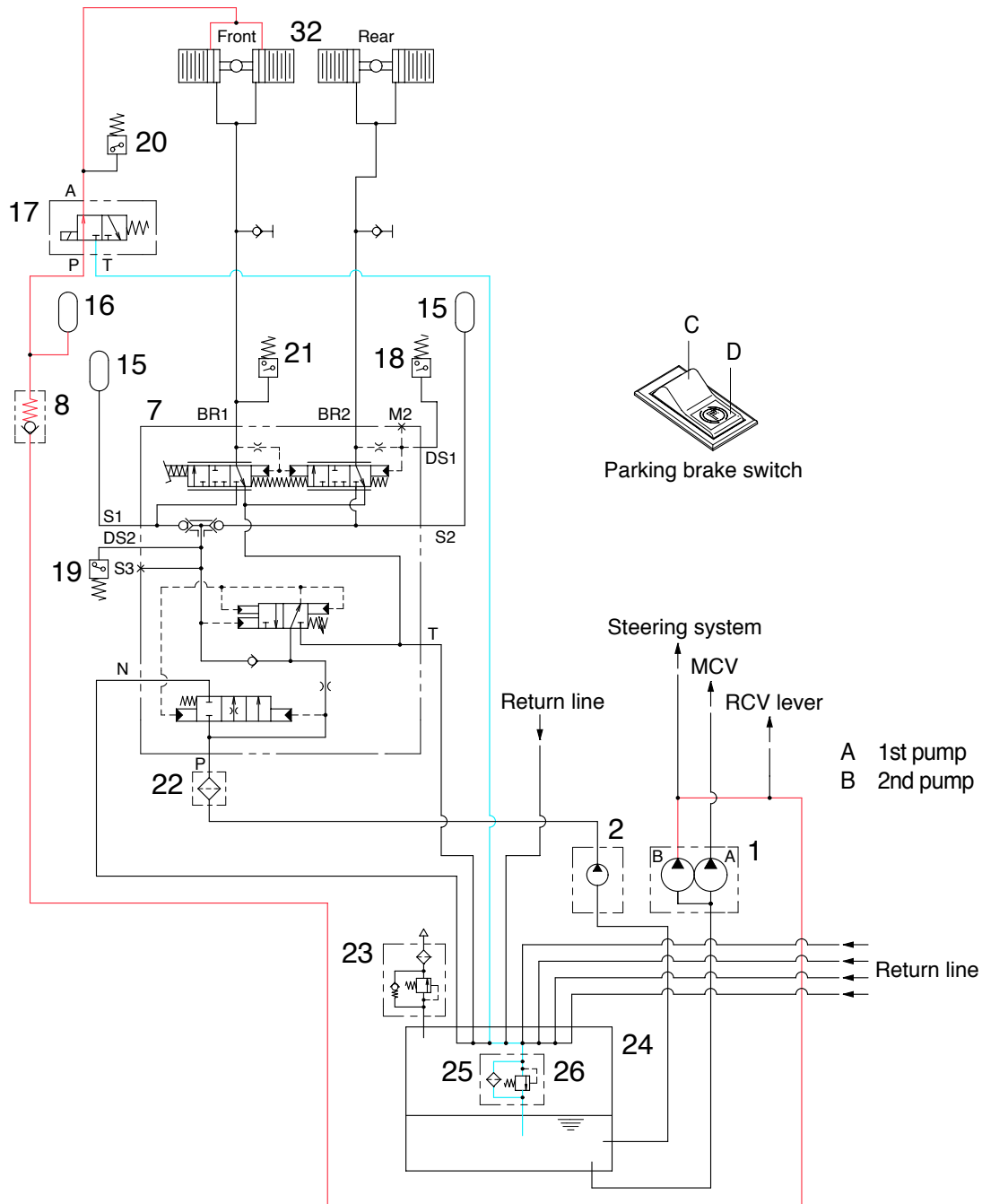

When the parking brake switch is pushed D position, the solenoid valve(17) is energized and the hydraulic oil enters the front axle. It overcomes the force of the spring and pushes the piston. This releases the brake.

Therefore, the hydraulic oil pressure is applied to the parking brake piston in front axle through the solenoid valve(17) and the parking brake is kept released.

4) PARKING BRAKE OPERATED

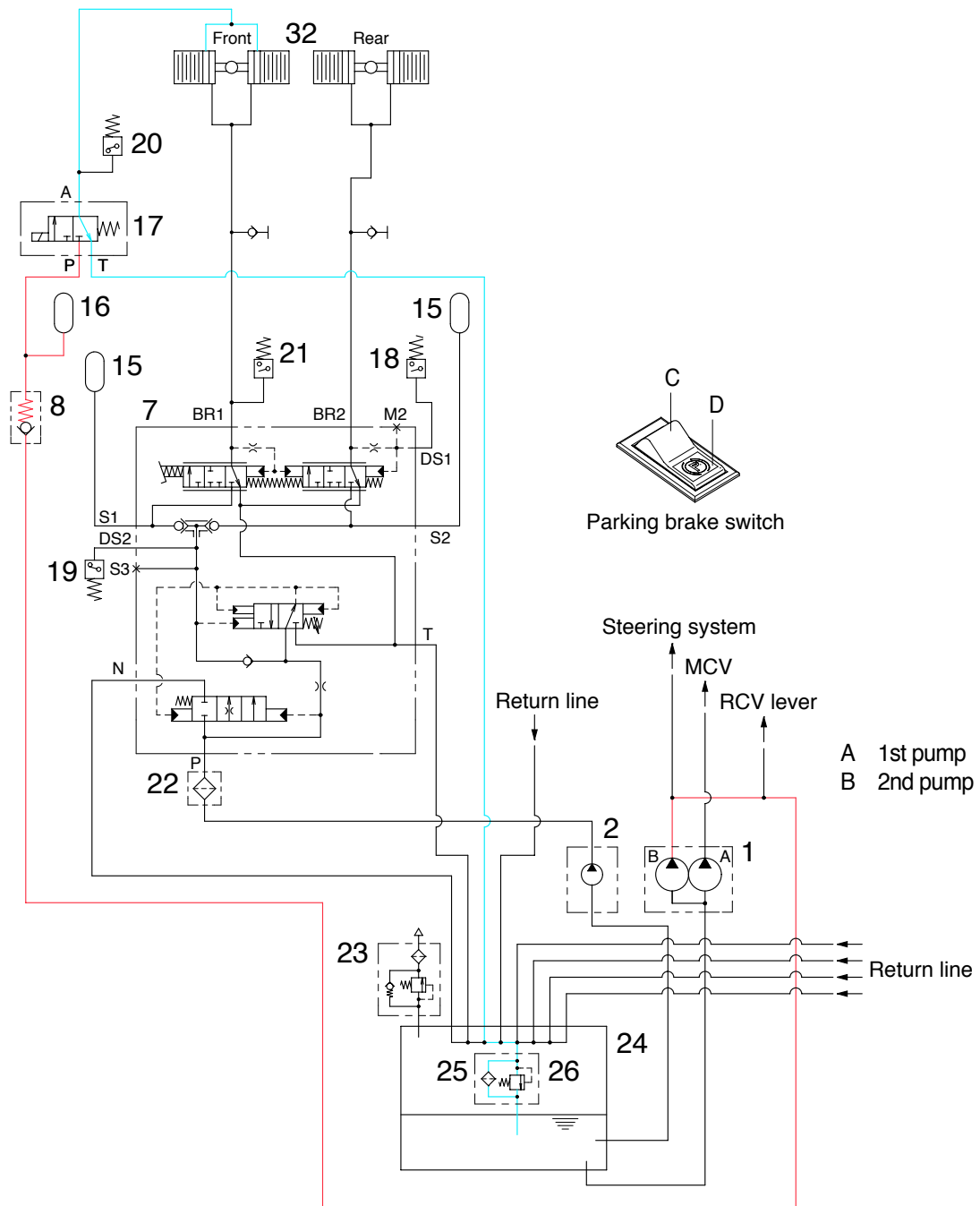

When the parking brake switch is pushed C position, the solenoid valve(17) is deenergized and the valve open the exhaust port.

At the same time, the hydraulic oil return to the tank through the solenoid valve(17). When the piston is returned by the force of the spring, the parking brake is applied.

3. BRAKE PUMP

1) STRUCTURE

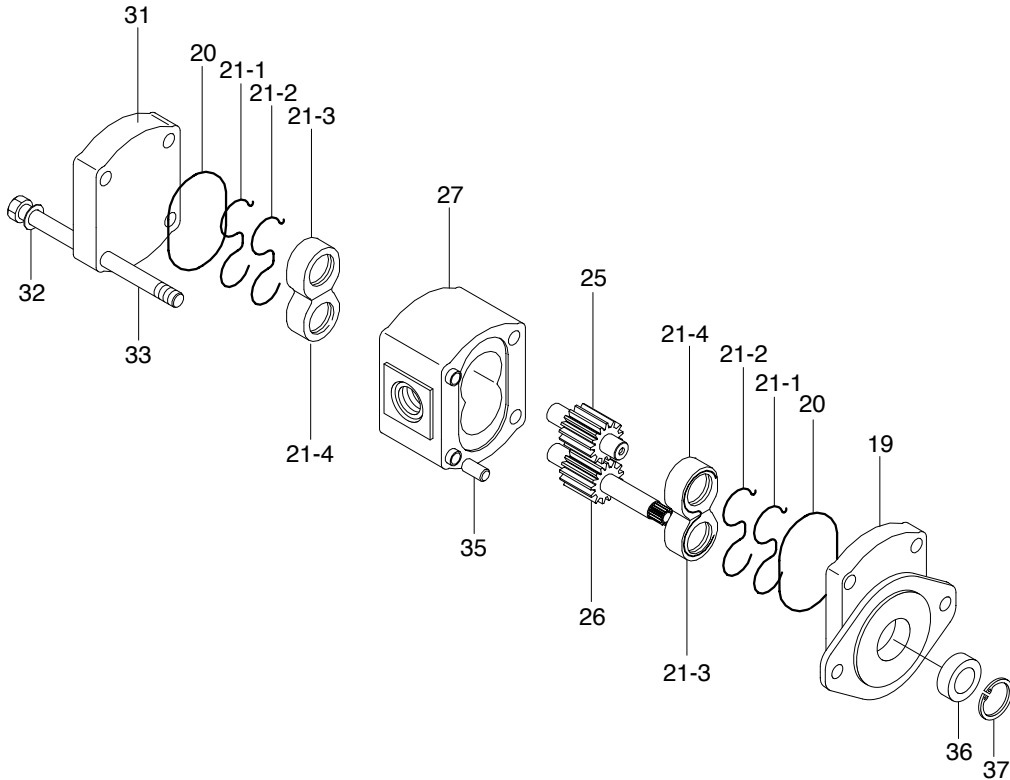

19	Flange	21-4	Rear bushing	32	Spring washer
20	O-ring	25	Driven gear	33	Bolt
21	Bushing block assy	26	Drive gear	35	Dowel
21-1	Back up seal	27	Body	36	Shaft seal
21-2	Bushing seal	31	Cover	37	Circlip
21-3	Rear bushing				

Hydraulic pumps used for the work equipment hydraulic units on construction machinery are pressure loaded type gear pumps. This gear pump have a maximum delivery pressure of 150kgf/cm²(2130psi). The pressure loaded type gear pump is designed so that the clearance between the gear and the side plate can be automatically adjusted according to the delivery pressure. Therefore, the oil leakage from the side plate is less than that in the case of the fixed side plate type under a high discharge pressure. Consequently, no significant reduction of the pump delivery occurs, even when the pump is operated under pressure.

2) PRINCIPLE OF OPERATION

(1) Mechanism for delivering oil

The drawing at right shows the operational principle of an external gear pump in which two gears are rotating in mesh.

The oil entering through the suction port is trapped in the space between two gear teeth, and is delivered to the discharge port as the gear rotates.

Except for the oil at the bottom of the gear teeth, the oil trapped between the gear teeth, is prevented from returning to the suction side with the gears in mesh.

Since the gears are constantly delivering oil, the oil delivered to the discharge port is forced out of the port.

The amount of discharge increases with the speed of rotation of the gear.

If there is no resistance in the oil passage into which the discharged oil flows, the oil merely flows through the passage, producing no increase in pressure.

If however, the oil passage is blocked with something like a hydraulic cylinder, there will be no other place for the oil to flow, so the oil pressure will rise. But the pressure which rises in this way will never go higher, once the hydraulic cylinder piston starts moving because of the oil pressure. As described earlier, the pump produces the oil flow, but not the oil pressure. We can therefore conclude that pressure is a consequence of load.

In other words, the pressure depends on a counterpart.

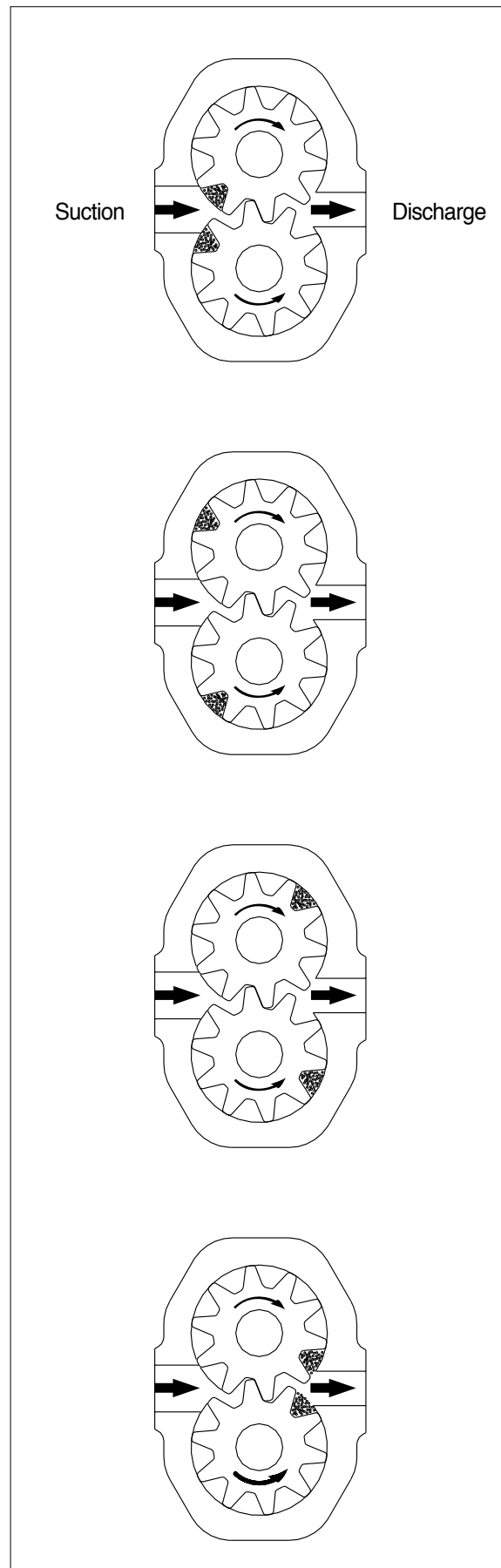

(2) Internal oil leakage

Oil leaks from a place under higher pressure to a place under lower pressure, provided that a gap or a clearance exists in between.

In the gear pump, small clearances are provided between the gear and the case and between the gear and the side plate to allow the oil to leak out and to serve as a lubricant so that the pump will be protected from seizure and binding.

The drawing at right shows how the leaked oil flows in the pump. As such, there is always oil leakage in the pump from the discharge side (Under higher pressure) to the suction side. The delivery of the pump is reduced by an amount equal to the pump discharge.

In addition, the delivery of the pump will also decrease as the amount of oil leakage increases because of expanded radial clearance resulting from the wear of pump parts, the lower oil viscosity resulting from increases in the oil temperature, and the initial use of low viscosity oil.

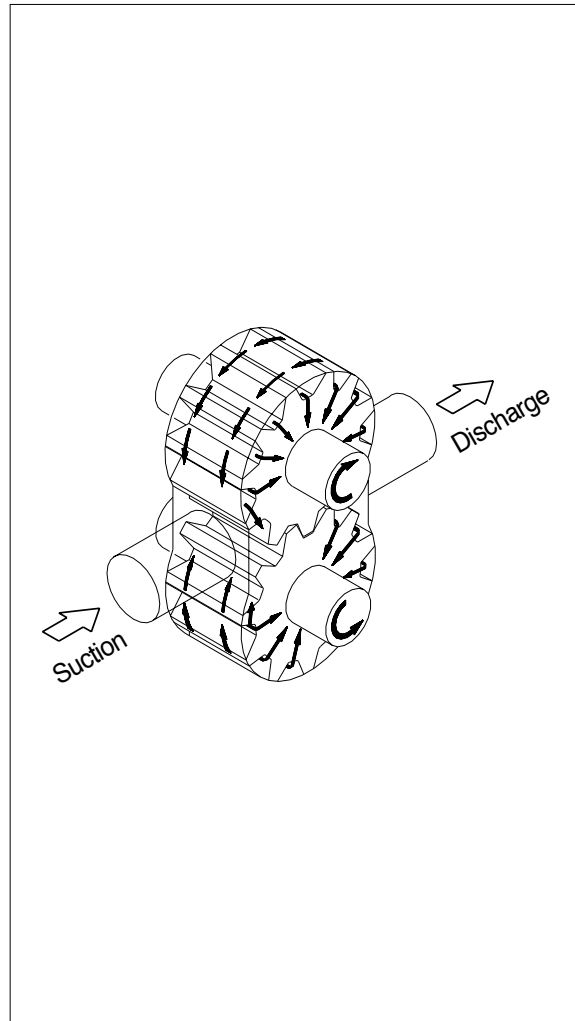

(3) Forces acting on the gear

The gear, whose outer surface is subjected to oil pressure, receives forces jointing towards its center.

Due to the action of the delivery pressure, the oil pressure is higher on the delivery side of the pump, and due to suction pressure, is lower on the suction side. In the intermediate section, the pressure will gradually lower as the position moves from the delivery side to the suction side.

This phenomenon is shown in the drawing at right.

In addition, the gears in mesh will receive interacting forces.

These forces pushing the gears toward the suction side are received by the bearings. Since the gears are pressed toward the suction side by these forces, the radial clearance becomes smaller on the suction side in the case. In some pumps, the clearance may become zero, thus allowing the gear teeth and the case to come into light contact.

For this reason, an excessive increase in the delivery pressure must be avoided, since it will produce a large force which will act on the gears, placing an overload on the bearings, and resulting in a shortened service life of the bearing or interference of the gear with the case.

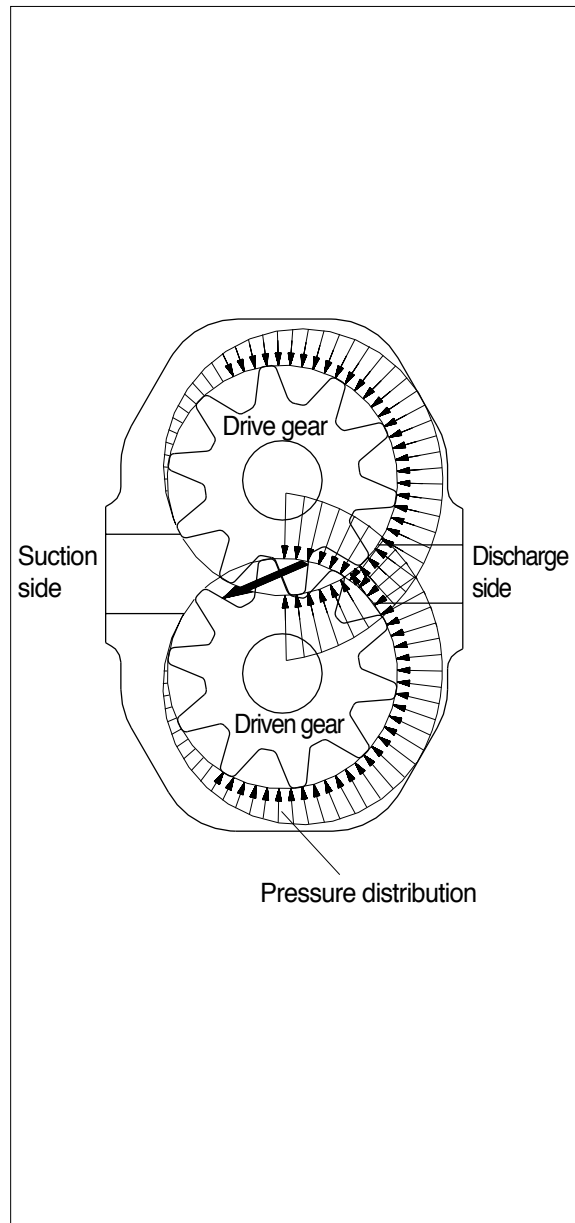

(4) "Trapping" phenomenon of the oil

When a gear pump is rotating with the gears in mesh as shown in the drawing at right, in some instances two sets of gear teeth are in mesh while in other instances only one set of the gear teeth is in mesh. When two sets of the teeth are in mesh simultaneously, the oil in the space between the meshed gear teeth will be trapped inside-the front and rear exits will be completely shut.

This is called the "trapping" phenomenon of oil.

The space in which the oil is trapped moves from the suction side to the delivery side as the gears rotate. The volume of the space gradually decreases from the start of trapping until the space reaches the center section, and then gradually increases after leaving the center section until the end of trapping.

Since the oil itself is non-shrinkable, a reduction of the volume of space will greatly increase the oil pressure, unless some provision is made to relieve oil pressure. The high pressure oil will cause the pump to make noise and vibrate.

To prevent this, relief notches are provided on the side plates to release the oil to the delivery side.

As shown in the drawing at right, the relief notches are provided in such a way that the oil can be relieved from the trapping space to the delivery side when the volume of the space is reduced.

Relief notches are also provided on the suction side to prevent the formation of a vacuum in the space by allowing the oil to enter the space from the suction side when the space is reduced.

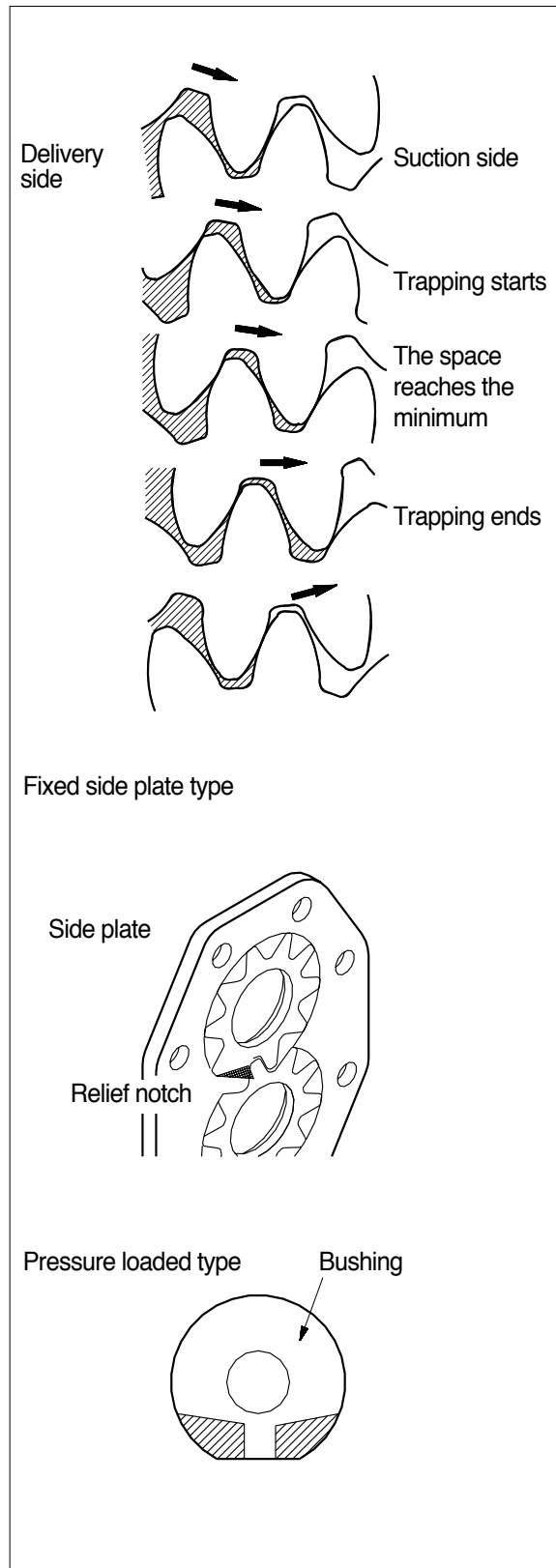

4. BRAKE VALVE

1) STRUCTURE

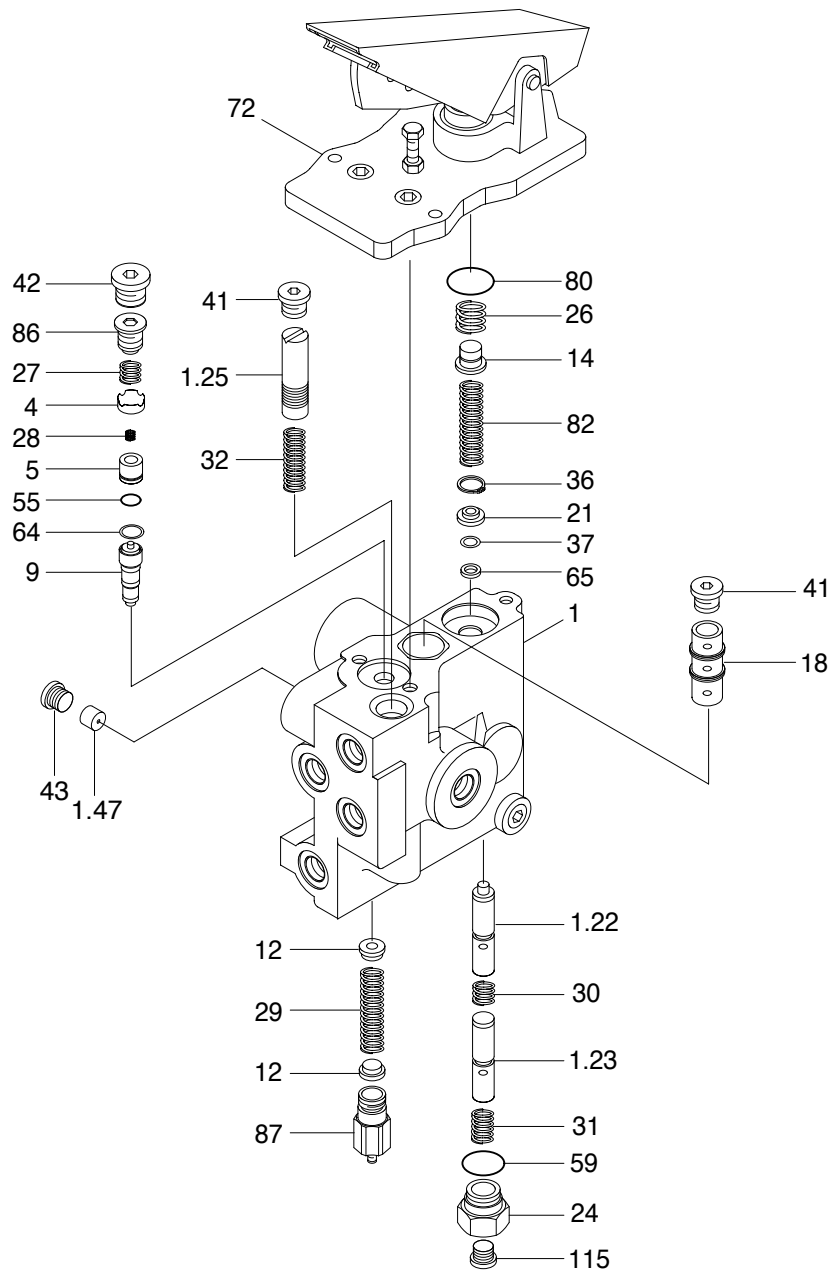

1	Housing	24	Reducer	43	Locking screw
1.22	Spool	26	Spring	55	O-ring
1.23	Spool	27	Spring	59	O-ring
1.25	Spool	28	Spring	64	Thrust ring
1.47	Spool	29	Spring	65	Shaft seal
4	Sleeve	30	Spring	72	Pedal unit
5	Sleeve	31	Spring	80	O-ring
9	Sleeve	32	Spring	82	Spring
12	Spring retainer	36	Circlip	86	Unit RV
14	Spring retainer	37	Circlip	87	Sleeve
18	Unit WVI	41	Locking screw	115	Locking screw
21	Spring retainer	42	Locking screw		

2) OPERATION

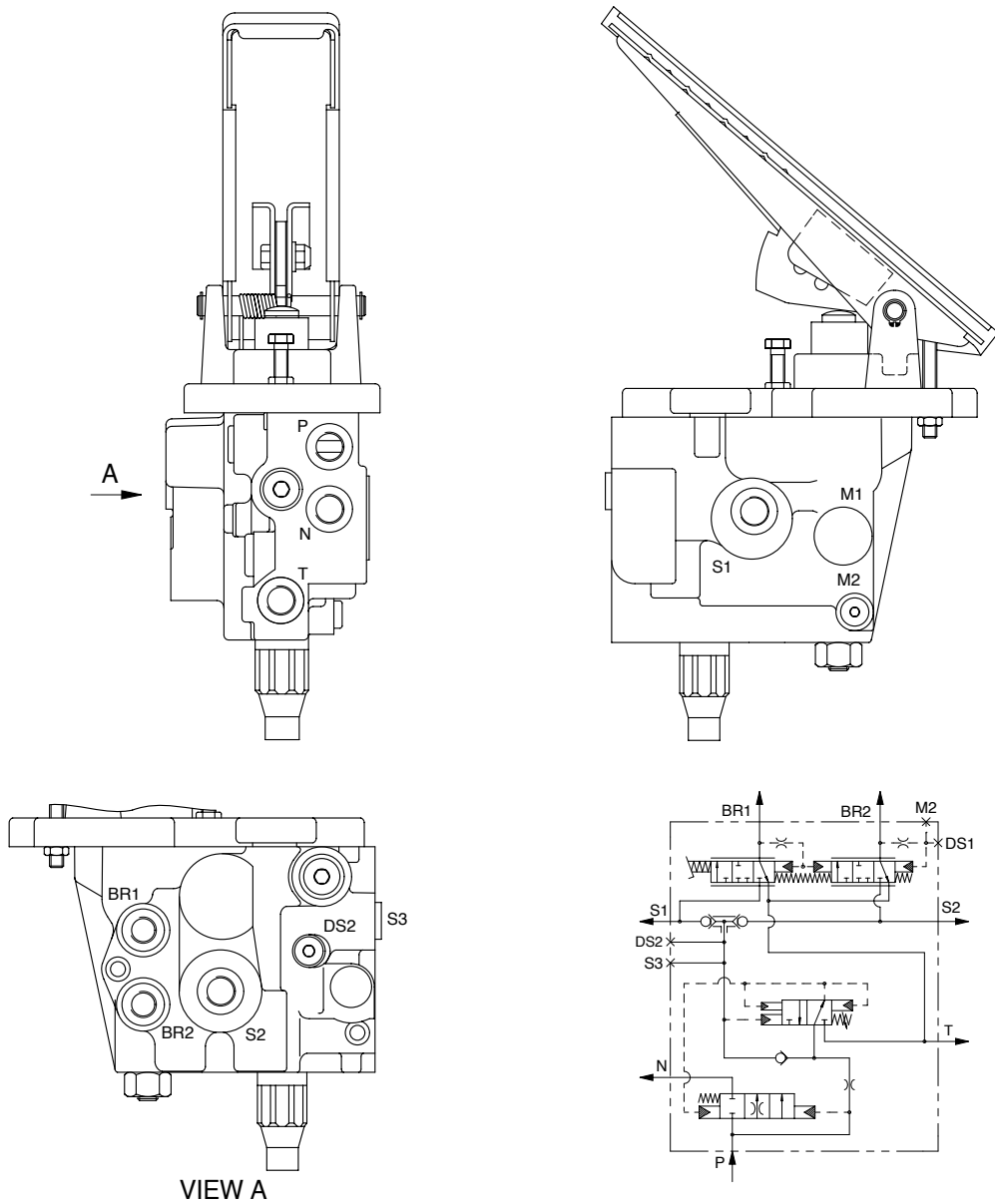

Port	Port name	Size
P	From main pump	M18 x 1.5
N	To hydraulic tank	M18 x 1.5
BR1	To service brake in front axle	M16 x 1.5
BR2	To service brake in rear axle	M16 x 1.5
DS1	Pressure switch stop light	M12 x 1.5
DS2	Pressure switch accumulator pressure	M12 x 1.5
S1	Accumulator service brake	M18 x 1.5
S2	Accumulator service brake	M18 x 1.5
S3	Accumulator parking brake	M16 x 1.5
M2	Accumulator parking brake	M12 x 1.5
T	To hydraulic tank	M16 x 1.5

(1) Accumulator charging valve

The accumulator loading valve or pressure switch-off valve has the purpose to keep a pressure level within certain limit values (Switch-off pressure, switch-on pressure) in an accumulator circuit. The switching pressure difference is approx 18% of the switch-off pressure.

If actuators (N) downstream from the pump produce a higher pressure than the switch-off pressure of the accumulator loading valve the accumulator circuit is raised to this pressure level.

The valve consists mainly of pilot control with pressure setting element (1), pressure compensator (2) and check valve (3).

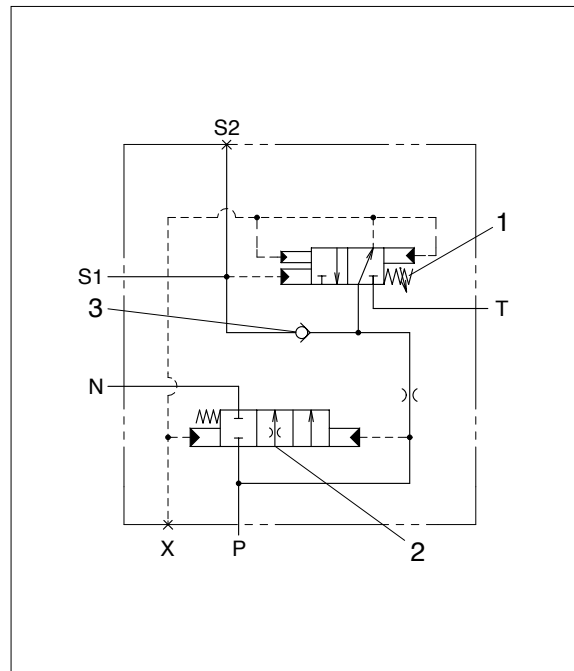

Switching over of pump flow from accumulator load into neutral circulation

The pump delivers into the accumulator circuit via the check valve (3) during the loading procedure. For this the pressure is passed to the load signal side of the pressure compensator (2) via the control line and pilot control. This throttles the pump flow until the pressure, which builds up in the accumulator circuit, overcomes the spring force of the pressure setting element (1).

The pilot control element switches the load signal line of the pressure compensator (2) from S1 to T. The pressure compensator (2) then switches the pump flow from P to N and the check valve (3) closes. The loading pressure is complete and the pump flow flows with low p through the loading valve.

Switching over of pump flow from neutral circulation into accumulator load

If the pressure in the accumulator circuit decreases to the lower switching point (Adding pressure) P is connected to the load signal chamber of the pressure compensator (2) and the pump delivers again into the accumulator circuit.

(2) 2 circuit brake valve

The 2-circuit remotely powered braking valve is direct controlled pressure relief valve in 3-way design with infinite mechanical operation.

It has a maximum pressure relief of secondary circuits and infinite adjustability of pressure in the secondary circuits (Braking circuits) proportional to the direction of the operating element(4).

With failure of one braking circuit the second braking circuit remains fully functional because of the mechanical contact of both spools(2).

The operating force at the pedal remains unchanged.

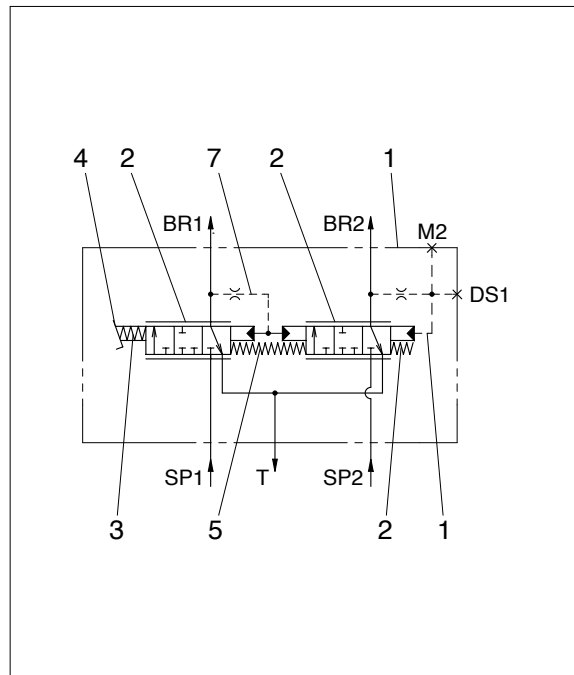

The 2-circuit remotely powered brake valve consists mainly of housing(1) and control spool(2), main compression spring(3), operating element(4) and the return springs(5) and (6).

The valve is operated via the operating element(4). It pushes the main control spring(3) against both control spools(2). First the control edges close at channel T, afterwards the flow from SP and BR is released in both braking circuits.

The pressure building up in the brake lines pushes simultaneously via the pilot oil drillings(7) behind the control spool against the main compression spring(3) so that the braking pressure(Secondary pressure) rises proportional to the operating element kept constant the control spools(2) moves into control position and holds the controlled pressure in channels BR1 and BR2 constant. The operating force of the operating element is proportional to its deflection.

When the main compression spring(3) is unloaded the pressure springs and the control spools move in such a way that they close SP towards BR and open BR towards T and thus close the secondary circuits(Braking circuits).

5. BRAKE ACCUMULATOR

1) STRUCTURE

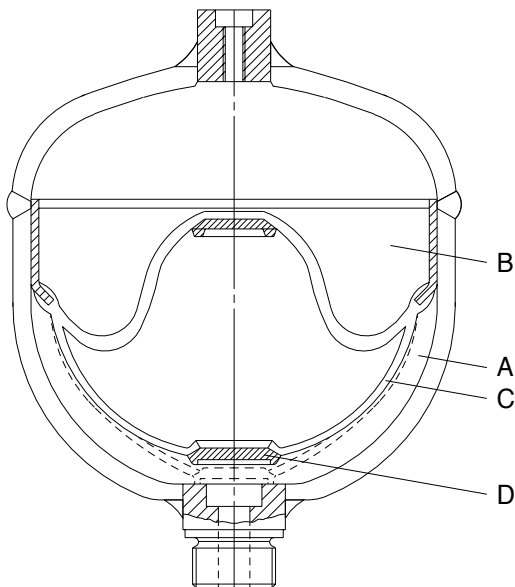

Item	31EC-0219 (Item16)	81L1-0004 (Item15)
Diameter	121mm	121mm
Mounting height	145mm	151mm
Norminal volume	0.075m ³	0.075m ³
Priming pressure	7kgf/cm ²	50kgf/cm ²
Operating medium	Oil	Oil
Operating pressure	Max 56kgf/cm ²	Max 180kgf/cm ²
Thread	M18 x 1.5	M18 x 1.5
Operating temperature range	-30 ~ 80, C	-30 ~ 80, C
Priming gas	Nitrogen	Nitrogen

A Fluid portion

B Gas portion

C Diaphragm

D Valve disk

2) OPERATION

(1) Purpose

Fluids are practically incompressible and are thus incapable of accumulating pressure energy. In hydropneumatic accumulators, the compressibility of a gas is utilized to accumulate fluid. The compressible medium used in the accumulators is nitrogen.

In braking systems, the purpose of the accumulators is to store the energy supplied by the hydraulic pump. They are also used as an energy reserve when the pump is not working, as a compensator for any losses through leakage, and as oscillation dampers.

(2) Operation

The accumulator consists of a fluid portion(A) and a gas portion(B) with a diaphragm(C) as a gas-tight dividing element. The fluid portion(A) is connected to the hydraulic circuit, causing the diaphragm accumulator to be filled and the gas volume to be compressed as the pressure rises.

When the pressure falls, the compressed gas volume will expand, thus displacing the accumulated pressure fluid into the circuit.

The diaphragm bottom contains a valve disk(D) which, if the diaphragm accumulator is completely empty, closes the hydraulic outlet, thus preventing damage to the diaphragm.

(3) Installation requirements

The accumulators can be fitted in the hydraulic circuit, directly on a component or in blocks on suitable consoles.

They should be fitted in as cool a location as possible.

Installation can be in any position.

(4) Maintenance of the accumulator

No special maintenance beyond the legal requirements is necessary.

The accumulator should be checked annually. It should be replaced if the initial gas pressure has fallen by more than 30% (Please refer to **Performance testing and checking of the accumulator**).

(5) Disposal of the accumulator

Before the accumulator is scrapped, its gas filling pressure must be reduced. For this purpose, drill a hole through gas chamber (B) using a drill approx. 3mm in diameter. The gas chamber is located on the side opposite the threaded port above the welding seam around the center of the accumulator.

Wear safety goggles when doing this job.

(6) Performance testing and checking of the accumulator

The accumulator is gradually pressurized via the test pump; until the initial gas pressure is reached, the hydraulic pressure in the accumulator will rise abruptly. This is apparent from gauge **M**. If the initial gas pressure is more than 30% below the prescribed value, the accumulator needs to be replaced. If the measuring process needs to be repeated, wait for intervals of 3 minutes between the individual tests. Any accumulator whose initial gas pressure is insufficient must be scrapped following the instructions under **Disposal of the accumulator**.

The amount of initial gas pressure can also be checked from the vehicle. Start the vehicle's engine. The pump will now supply oil to the accumulators. Until the initial gas pressure is reached, the hydraulic pressure in the accumulator will rise abruptly. This is apparent from the gauge in the cab. If the initial gas pressure is more than 30% below the prescribed value, that initial pressure lies outside the permissible range for **at least one** of the accumulators fitted in the vehicle. This accumulator can be traced only by using the method described above, i.e. all accumulators have to be individually tested. The accumulator whose initial gas pressure is insufficient must be replaced and scrapped following the instruction under **Disposal of the accumulator**.

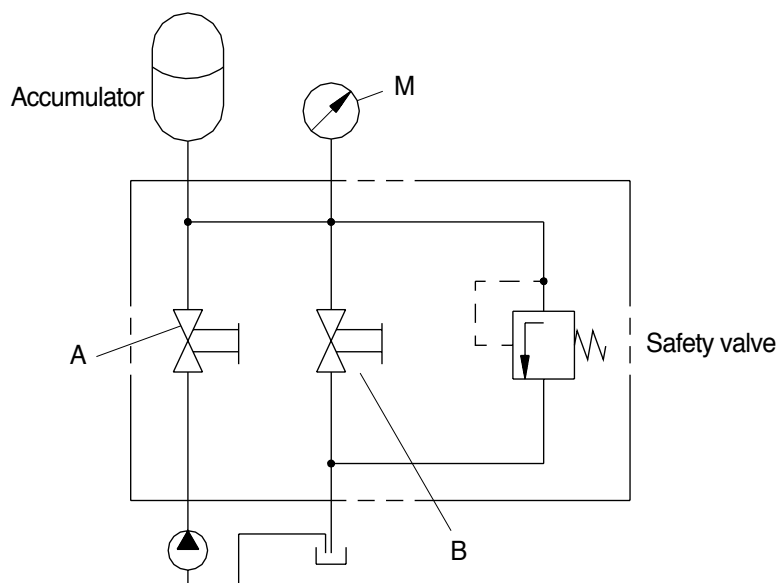

(7) Repair work

△ **When working on the braking system, always make sure that there is absolutely no pressure in the system. Even when the engine is switched off there will be some residual pressure in the system.**

When doing repair work, make sure your environment is very clean.

Immediately close all open ports on the components and on pipes using plugs.

△ **For safety reasons the accumulators need to be replaced as a whole if damaged.**

6. PRESSURE SWITCHES

1) STRUCTURE

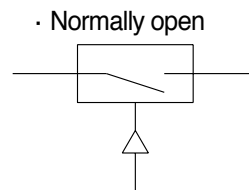
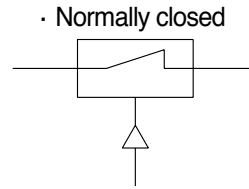
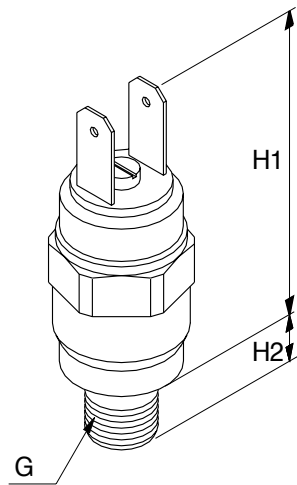

· Technical data

Item	Type	Medium	G	H1 mm	H2 mm	Adjusting range kg/cm ²	Adjusting pressure kg/cm ²	Voltage V
Parking	NC	Oil	M12 × 1.5	55	9	10 ~ 20	13 ± 1	Max 42
Charging	NC	Oil	M12 × 1.5	55	9	20 ~ 50	45 ± 2	Max 42
Brake stop	NO	Oil	M12 × 1.5	55	9	1 ~ 10	5 ± 1	Max 42
Clutch cut off	NO	Oil	M10 × 1.0	55	9	20 ~ 50	25 ± 1	Max 42

NC : Normally closed

NO : Normally open

2) OPERATION

(1) Purpose

The pressure switches are used to visually or audibly warn the driver of the pressure within the system.

(2) Make contact / circuit closer

The pressure switch can be fitted in the braking system or directly on one of its components. The system pressure acts on an absorption area within the switch, making an electrical contact as the pressure on that area is increased. The resulting current is used to activate a warning facility, for instance.

(3) Break contact / circuit breaker

The pressure switch can be fitted in the braking system or directly on one of its components. The system pressure acts on a absorption area within the switch, breaking an electrical contact as the pressure on that area is increased. The current is now broken, e.g. to deactivate a warning facility.

(4) Installation requirements

No special measures need to be taken.

(5) Maintenance of the pressure switch

No special maintenance beyond the legal requirements is necessary.

When using high-pressure cleaners on the vehicle, please make sure that the water jet is not directed at the pressure switch (Corrosion of contacts).

(6) Repair work

△ **When working on the braking system, always make sure that there is absolutely no pressure in the system. Even when the engine is switched off there will be some residual pressure in the system.**

When doing repair work, make sure your environment is very clean.

Immediately close all open ports on the components and on pipes using plugs.

For safety reasons the pressure switch needs to be replaced as a whole if damaged.

(7) Adjusting and testing pressure switch

The adjusting screw located between the two contact plugs can be set to the desired value within a certain range. For adjusting range, please refer to the table **Technical data** on the previous page.

After making the adjustment, the adjusting screw should be secured using wax or a similar material.

