

**SECTION 2 ENGINE**



Group 1 Structure and Function ----- 2-1

# SECTION 2 ENGINE

## GROUP 1 STRUCTURE AND FUNCTION

### 1. STRUCTURE

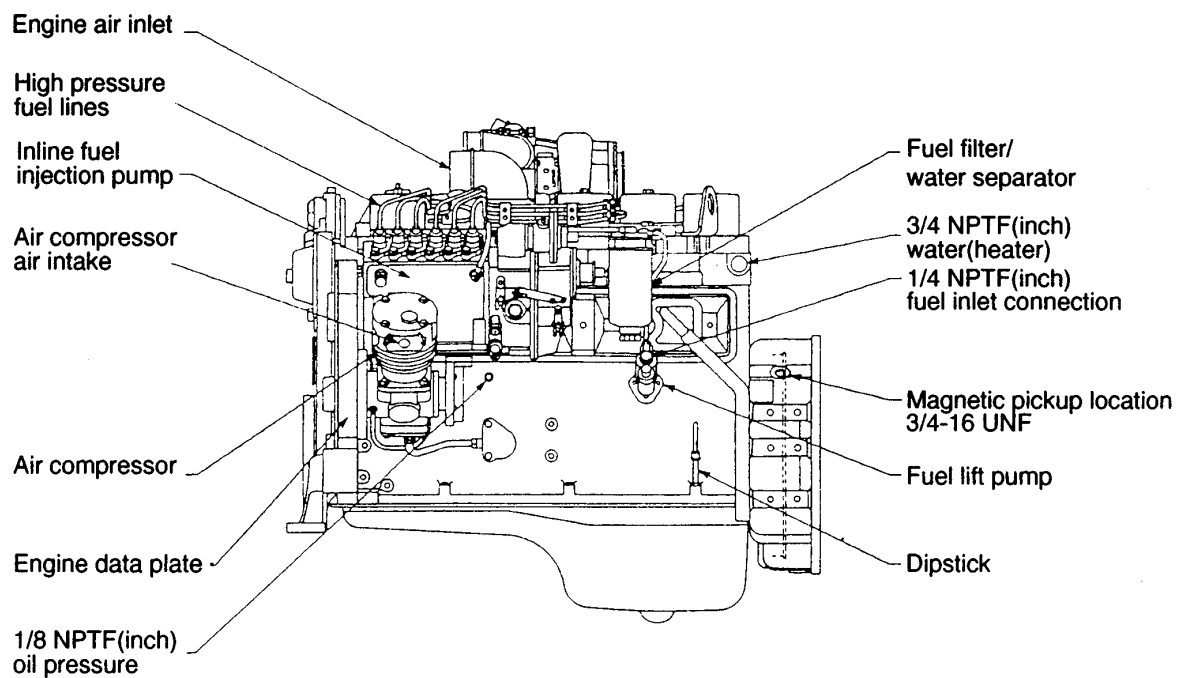
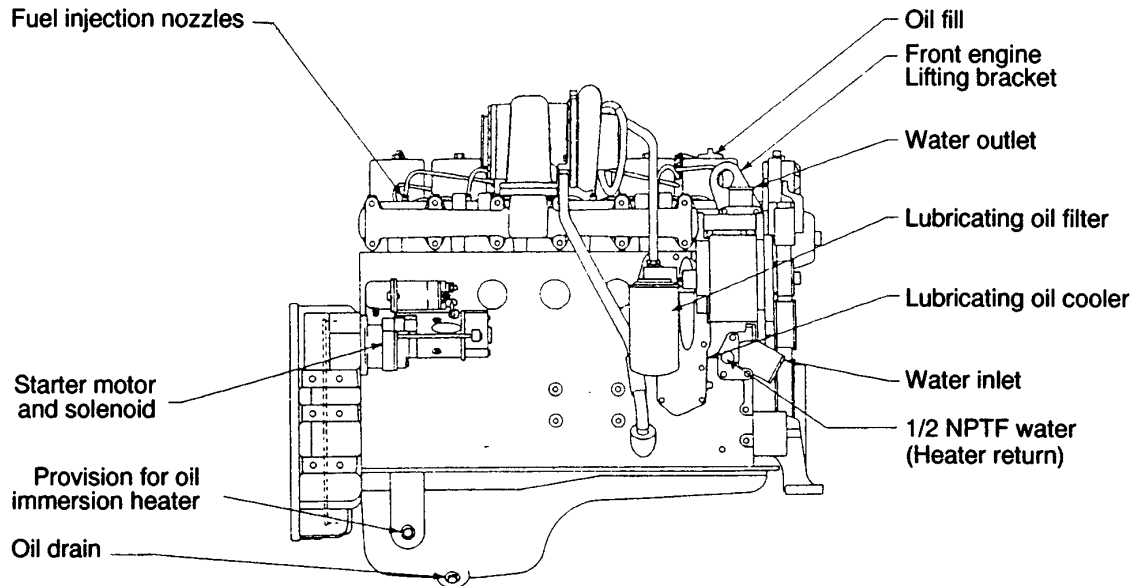

- Direct 4-stroke, 6-cylinders, water-cooling diesel engine in installed, cylinder block and cylinder head are made of case iron and turbocharger is attached.
- Gears in engine gear case are manufactured as helical gear to reduce the noise and arranged in the manner of smooth power transmitting.
- Cylinder block is designed for the oil cooler and cooling pump to be built in each passage for lubrication and cooling water are formed as a set.
- Fan belt is poly V-belt improving the life, and manual tension adjuster of fan belt in installed.

## 2. COOLING SYSTEM

1) Coolant is drawn from the radiator by the integrally mounted water pump. The output from the water pump empties into the oil cooler cavity of the cylinder block.

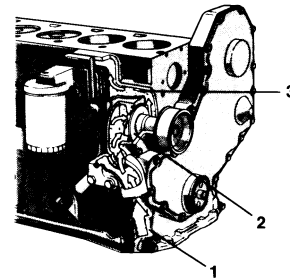

2) The coolant then circulates around each cylinder and crosses the block to the fuel pump side of the engine.

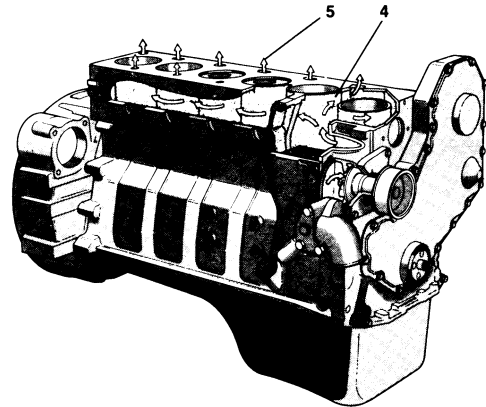

### Cylinder block

- 1 Coolant inlet
- 2 Pump impeller
- 3 Coolant flow past oil cooler
- 4 Coolant flow past cylinders
- 5 Coolant to cylinder head

3) Coolant then flows up into the cylinder head, crosses over the valve bridges and down the exhaust manifold side of the engine to the integral thermostat housing.

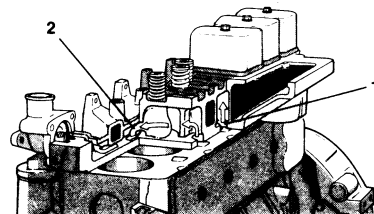

### Cylinder head

- 1 Coolant flow from cylinder block
- 2 Coolant to thermostat housing

4) As the coolant flows across the head toward the thermostat housing, it provides cooling for the injector nozzle.

When the engine is below operating temperature, the thermostat is closed, and the coolant flow bypasses the radiator and goes to the water pump inlet via internal drillings in the block and cylinder head.

### Thermostat

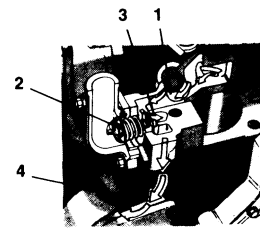

### Closed

- 1 Coolant flow past injector
- 2 Thermostat
- 3 Coolant bypass passage
- 4 Coolant flow to pump inlet

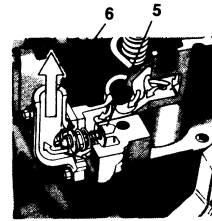

### Open

- 5 Bypass closed
- 6 Coolant flow back to radiator

### 3. FUEL SYSTEM

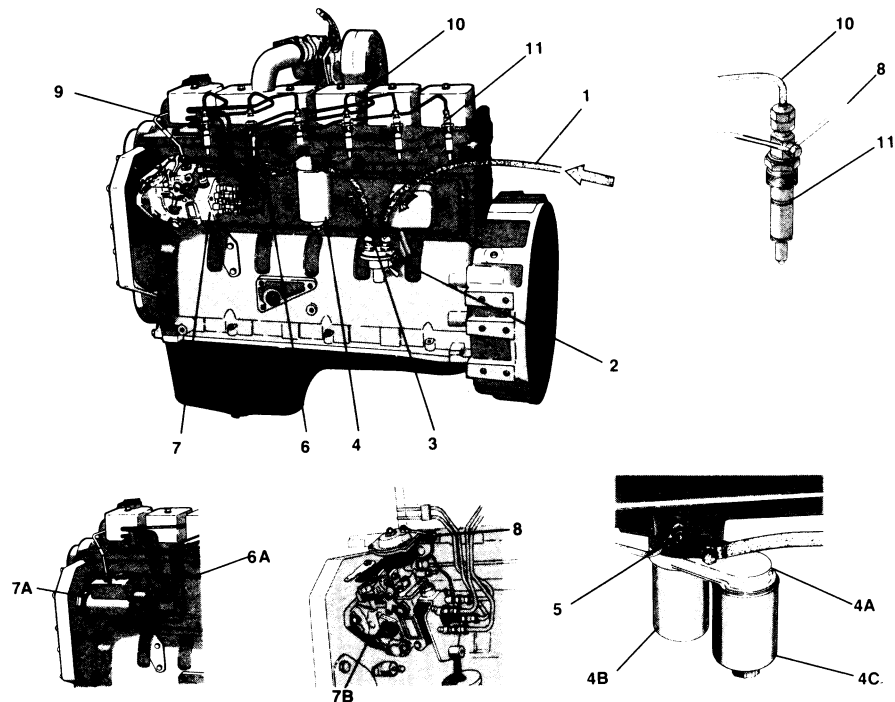

- |    |                              |    |   |    |  |
|----|------------------------------|----|---|----|--|
| 1  | Fuel from supply tank        | 6  | Low pressure supply line                                  | 8  | Turbo boost control line                               |
| 2  | Lift pump                    |    | (Robert bosch)  | 9  | Fuel drain manifold                                    |
| 3  | Low pressure supply line     | 6A | Low pressure supply line                                  | 10 | High pressure lines                                    |
| 4  | Fuel water separator/ filter |    | (Lucas CAV)   | 11 | Robert bosch, 17mm, closed nozzle, hole type injectors |
| 4A | Dual filter adapter          | 7  | Robert bosch VE distributor type injection pump           |    |  |
| 4B | Fuel filter                  |    |   |    |  |
| 4C | Fuel water separator /filter | 7A | Lucas CAV DPA distributor type injection pump, automotive |    |  |
| 5  | Bleed screw                  |    |   |    |  |

The engine will be equipped with a cam-actuated lift pump. Fuel flow begins as the lift pump pulls fuel from the supply tank. The pump supplies low-pressure fuel(21-35kPa, 3-5psi) to the fuel filter head, through the filter and then to the distributor injection pump.

The engine uses distributor-type fuel pumps supplied by Robert Bosch.

The distributor pump builds the high injection pressure required for combustion, and routes the fuel through individual high-pressure fuel lines to each injector.

When the high-pressure fuel reaches the injector, the pressure lifts the needle valve against the spring tension to let the fuel enter the combustion chamber.

Any leakage past the needle valve enters the fuel drain manifold. The fuel drain manifold routes controlled venting from the distributor injection pump and leakage from the injectors back into the fuel tank.

## 4. LUBRICATING SYSTEM

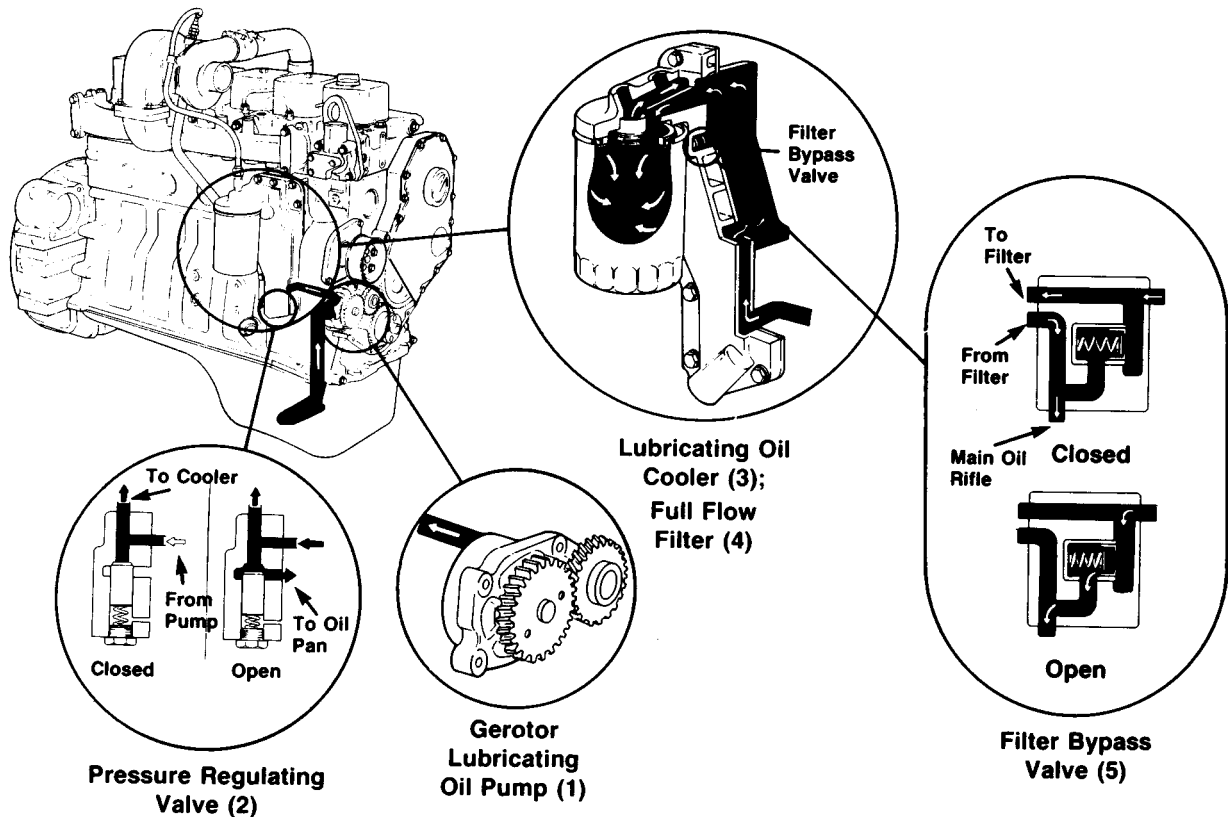

### LUBRICATING OIL PUMP

The engine use gerotor type oil pumps(1).

### PRESSURE REGULATING VALVE

The pressure regulating valve(2) is designed to keep the oil pressure from exceeding 414kPa(60psi). When the oil pressure from the pump is greater than 414kPa(60psi), the valve opens uncovering the dump port so part of the oil is routed to the oil pan. Because of manufacturing tolerances of the components and the oil passages, the oil pressure can differ as much as 69kPa(10psi) between engines.

## **OIL COOLERS**

The engine uses full flow, plate type oil coolers (3). The oil flows through a cast passage in the cooler cover and through the element where it is cooled by engine coolant flowing past the plates of the element.

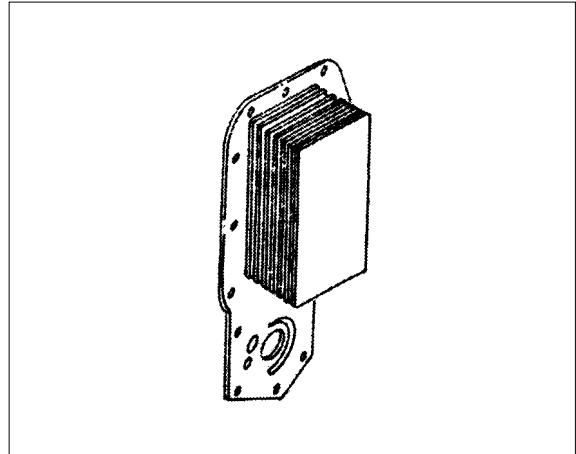

## **OIL FILTERS**

After the oil is cooled, it flows through the full flow oil filter(4).

### **OIL FILTER BYPASS VALVE**

The oil cooler cover contains a bypass valve(5) that will let the oil flow bypass a plugged filter. The valve is designed to open when the pressure drop across the filter is more than 138kPa(20psi), as with a plugged filter, and lets the oil continue on through the engine. When a filter becomes plugged, an oil pressure decrease of 60kPa(10psi) or less from the normal operating pressure can be observed on the machine oil pressure gauge.

## 5. INTAKE AND EXHAUST SYSTEM

### Intake system

- 1 Intake air inlet to turbocharger
- 2 Air to intake manifold
- 3 Intake manifold
- 4 Intake valve

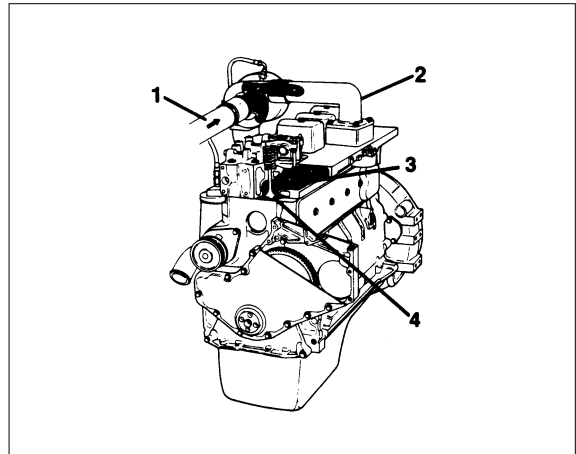

### Exhaust system

- 1 Exhaust valve
- 2 Exhaust manifold
- 3 Turbocharger inlet
- 4 Turbocharger exhaust outlet

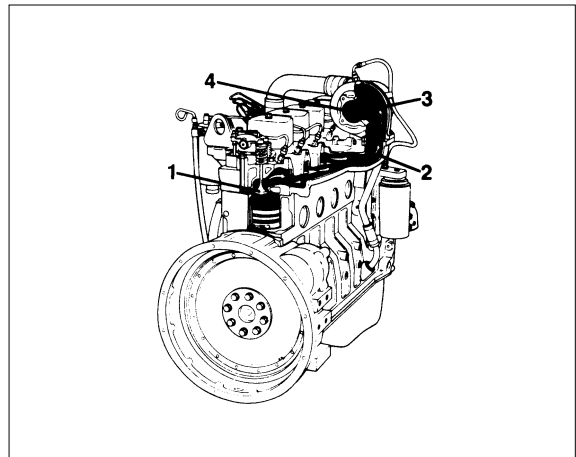

The engine is available in turbocharged.

Air is pulled into the engine from an air filter. Clean air is very important to the life of the engine. Ingested dust and dirt can damage the cylinders very quickly.

The air flow is from the filter to the turbocharger, and then through the crossover tube to the manifold. From the intake manifold, air is forced into the cylinder and used for combustion. The exhaust gases flow through the turbocharger to rotate the turbine and impeller, thereby utilizing exhaust energy to force more air into the cylinders. The additional air provided by the turbocharger allows more fuel to be injected to increase the power output from the engine. Thus, the power-to-weight ratio for the engine is increased significantly with the addition of the turbocharger.