

SECTION 5 STEERING SYSTEM

Group 1 Structure and Function	5-1
Group 2 Operational Checks and Troubleshooting	5-11
Group 3 Tests and Adjustments	5-17
Group 4 Disassembly and Assembly	5-23

SECTION 5 STEERING SYSTEM

GROUP 1 STRUCTURE AND FUNCTION

1. OUTLINE

The steering system of this machine consists of a variable piston pump supplying a load sensing steering system and an closed center loader system.

The components of the steering system are :

- Main pump
- Steering unit
- Cushion valve
- Steering cylinders

The main pump draws hydraulic oil from the hydraulic tank.

Outlet flow from the pump flows to the priority valve in main control valve. The priority valve in main control valve preferentially supplies flow, on demand, to the steering unit. When the machine is steered, the steering unit routes flow to the steering cylinders to articulate the machine.

When the machine is not being steered, or if pump flow is greater than steering flow, the priority valve supplies flow to the loader system.

That is, output flow from the pump enters into the main control valve for the operation of the attachment.

2. HYDRAULIC CIRCUIT

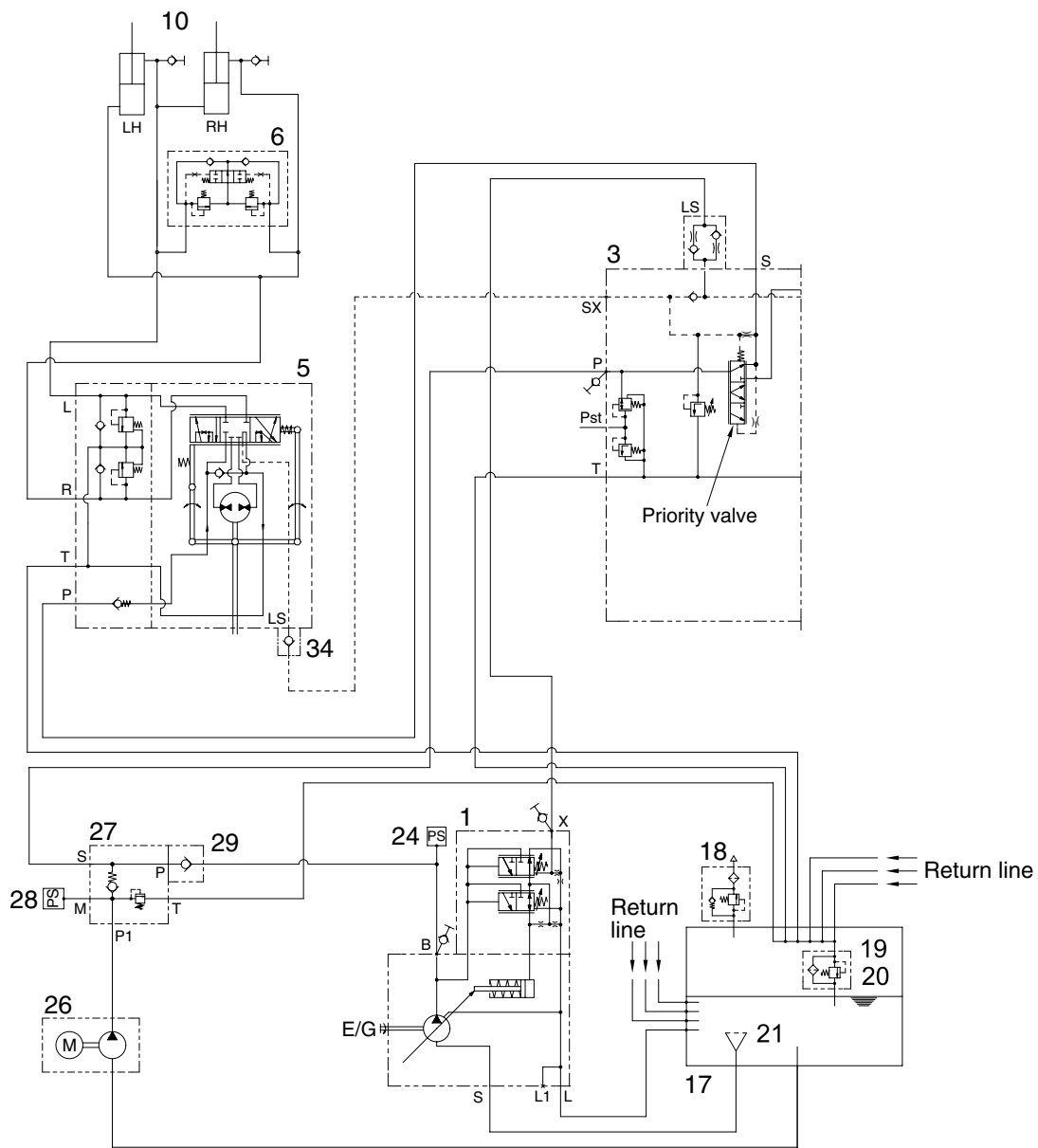

73095SE01

- | | | | | | |
|----|--------------------|----|---------------------|----|--------------------------|
| 1 | Main pump | 18 | Air breather | 27 | Check block (option) |
| 3 | Main control valve | 19 | Return filter | 28 | Pressure sensor (option) |
| 5 | Steering unit | 20 | Bypass valve | 29 | Check valve (option) |
| 6 | Cushion valve | 21 | Strainer | 34 | Check valve |
| 10 | Steering cylinder | 24 | Pressure sensor | | |
| 17 | Hydraulic tank | 26 | Motor pump (option) | | |

1) NEUTRAL

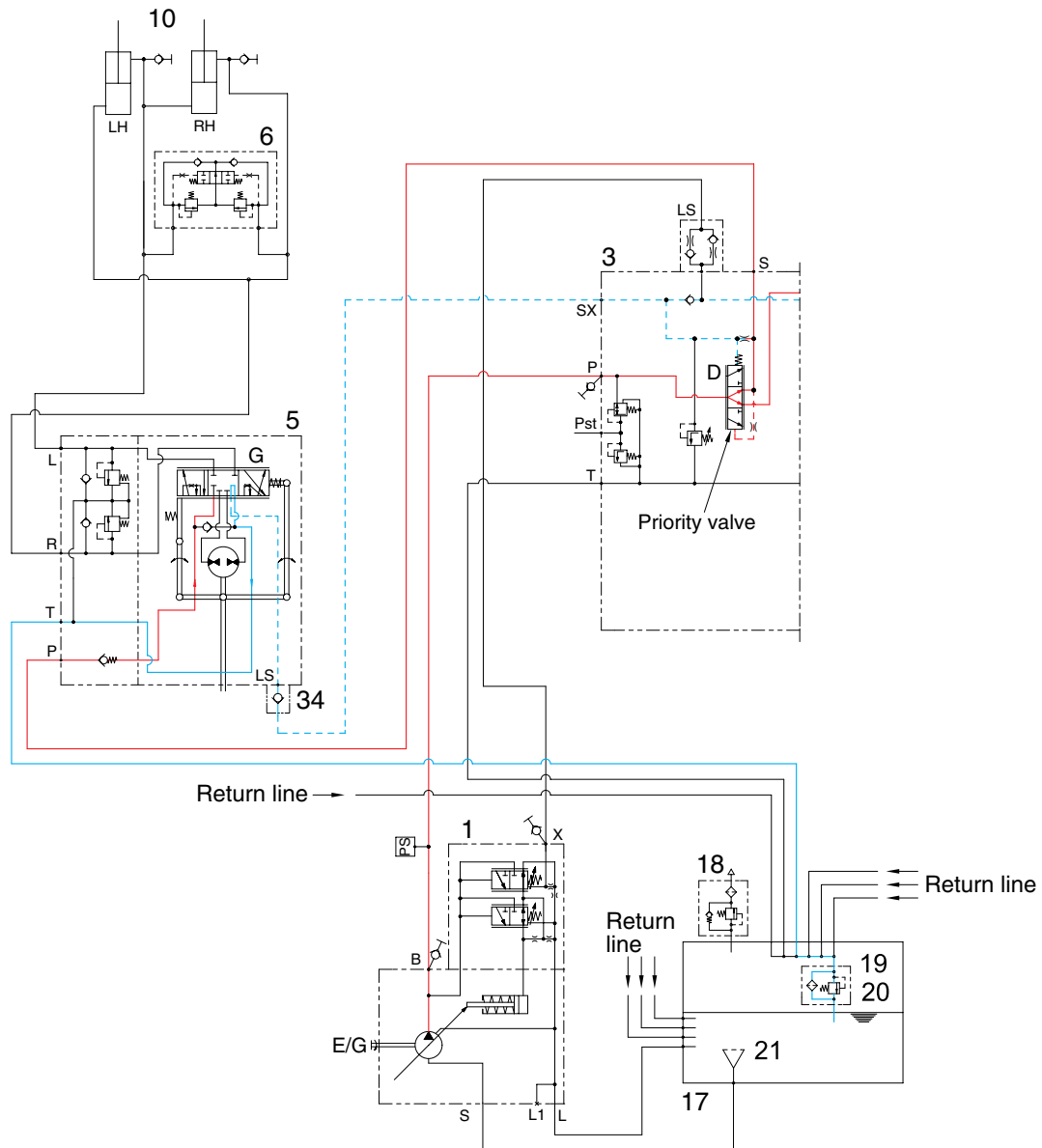

73095SE02

The steering wheel is not being operated so control spool (G) does not move.

The oil from the pump enters port P of the priority valve in main control valve and the inlet pressure oil moves the spool (D).

Almost all of pump flow goes to the loader system and partly flows into the hydraulic tank (17) through the spool (G).

2) LEFT TURN

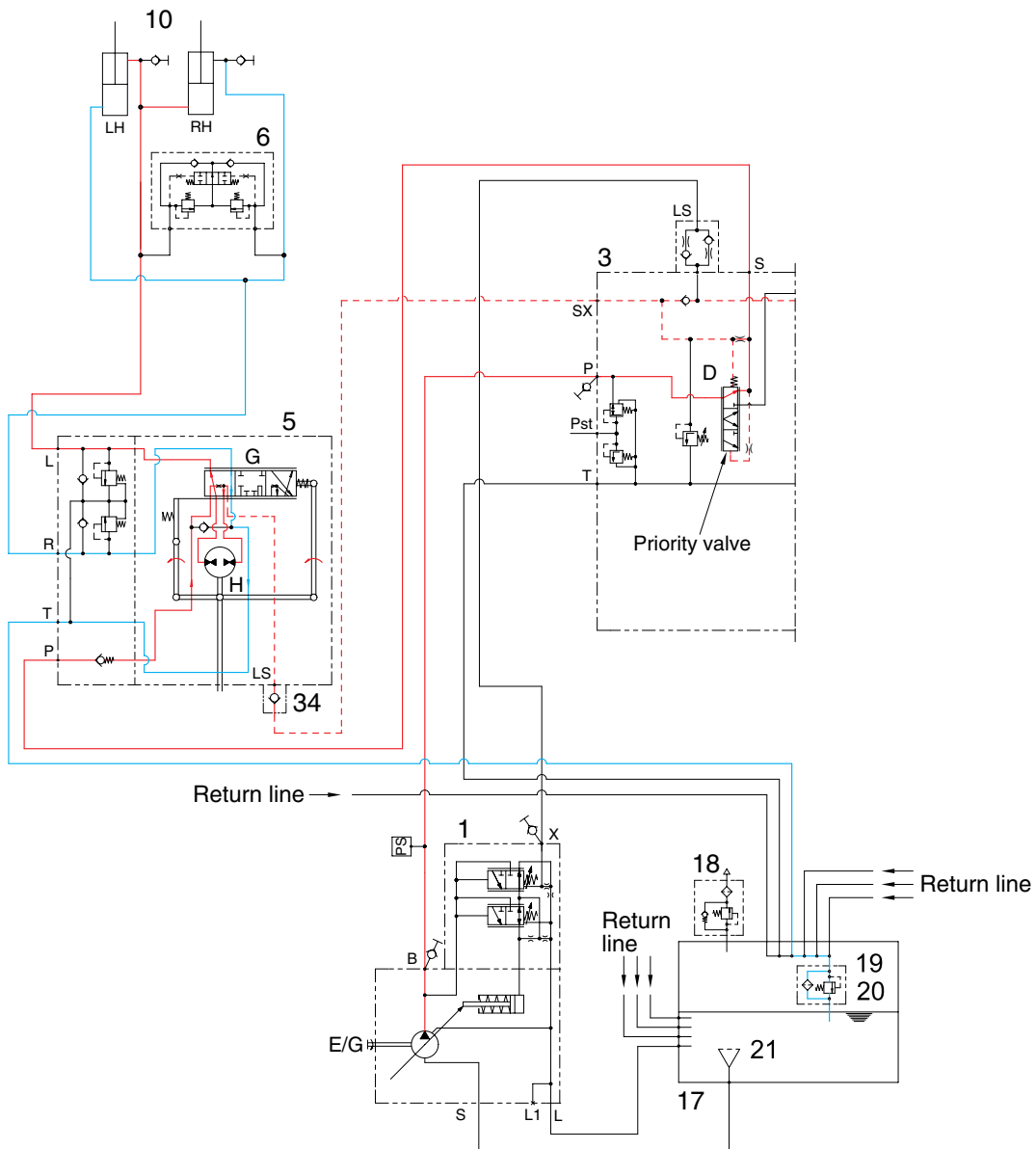

73095SE03

When the steering wheel is turned to the left, the spool (G) within the steering unit (5) connected with steering column turns in left hand direction.

At this time, the oil discharged from the pump flows into the spool (G) of the steering unit (5) through the spool (D) of priority valve in main control valve and flows into the gerotor (H).

Oil flow from the gerotor flows back into the spool (G) where it is directed out the left work port (L) to the respective chamber of the steering cylinders (10).

Oil returned from left and right cylinder returns to hydraulic tank through the spool (G) of the steering unit.

When the above operation is completed, the machine turns to the left.

3) RIGHT TURN

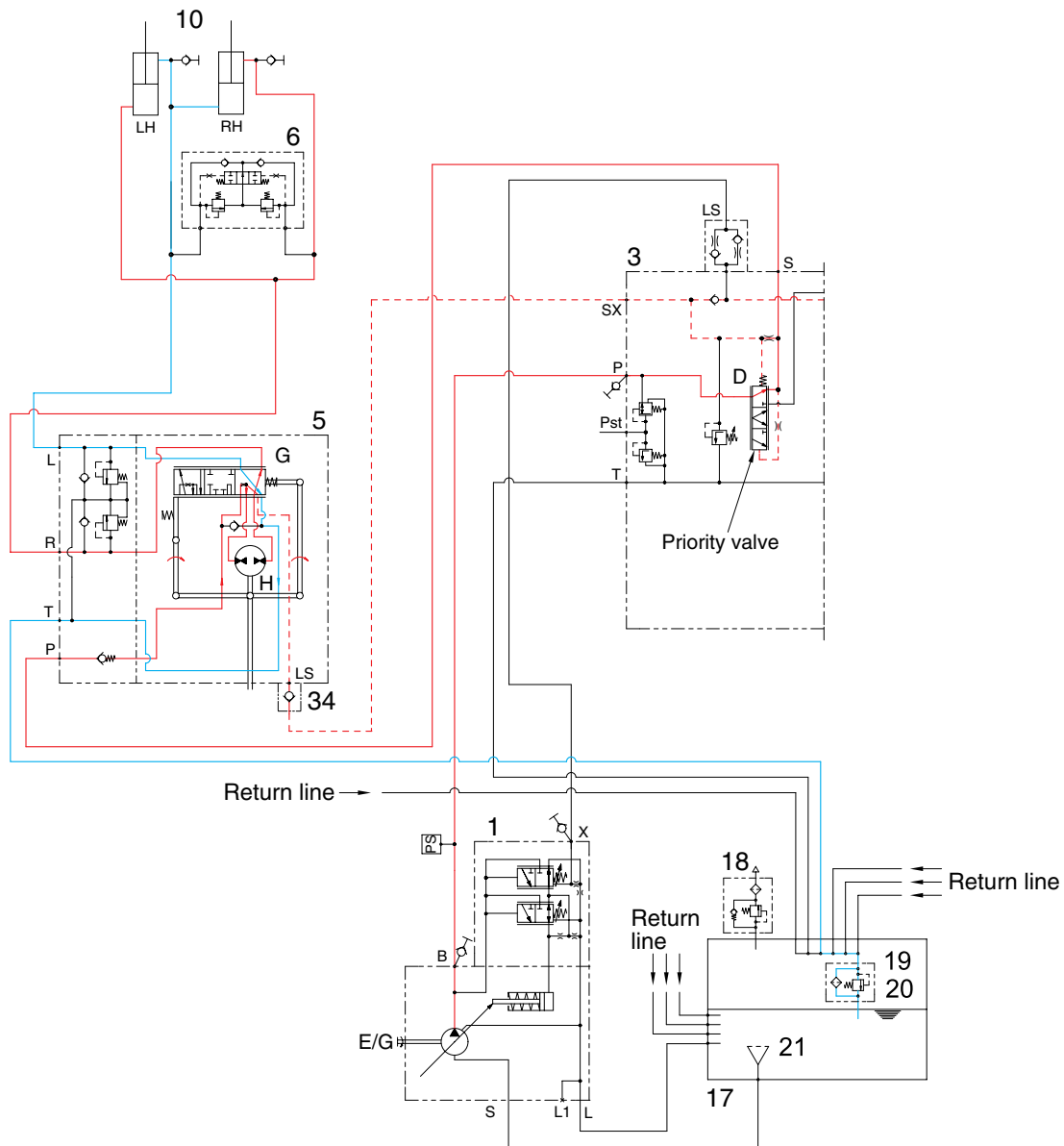

73095SE04

When the steering wheel is turned to the right, the spool (G) within the steering unit (5) connected with steering column turns in right hand direction.

At this time, the oil discharged from the pump flows into the spool (G) of the steering unit (5) through the spool (D) of priority valve in main control valve and flows into the gerotor (H).

Oil flow from the gerotor flows back into the spool (G) where it is directed out the right workport to the respective chamber of the steering cylinders (10).

Oil returned from left and right cylinder returns to hydraulic tank through the spool (G) of the steering unit.

When the above operation is completed, the machine turns to the right.

3. STEERING UNIT

1) STRUCTURE

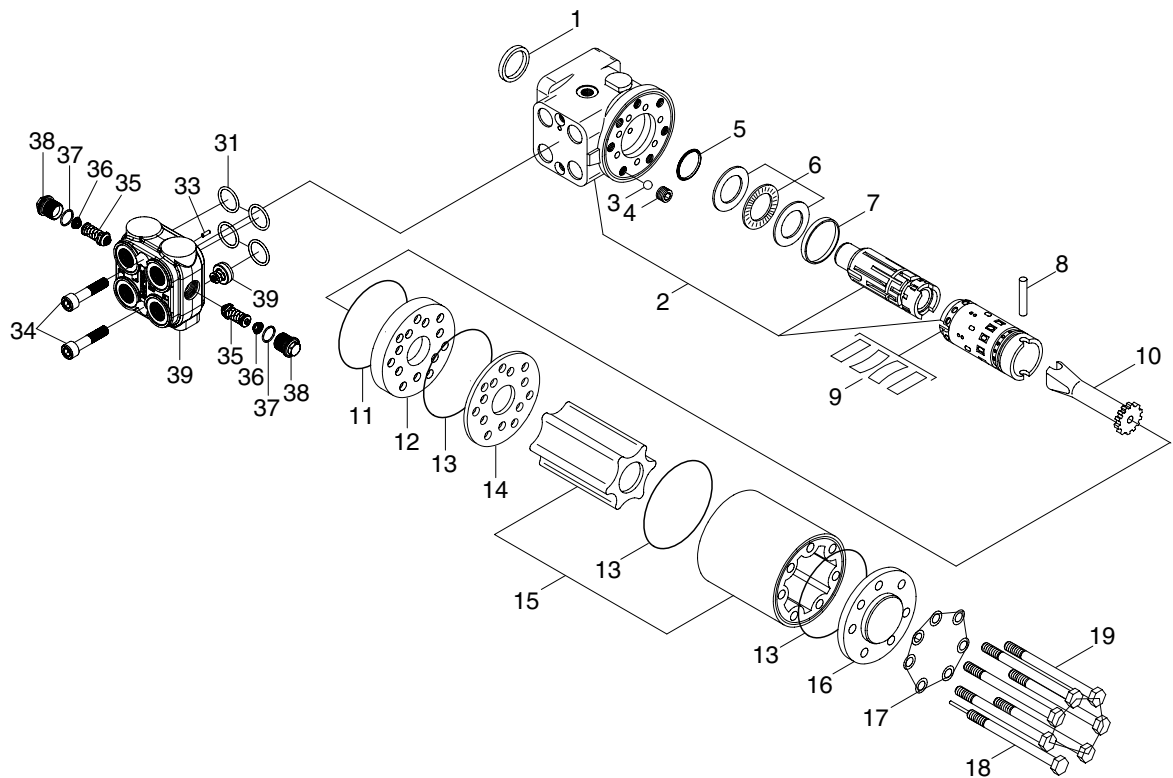

74095SE05

- | | | | | | |
|---|------------------------|----|--------------------|----|----------------------|
| 1 | Dust seal ring | 10 | Cardan shaft | 19 | Screw |
| 2 | Housing, spool, sleeve | 11 | O-ring | 31 | Set of O-rings |
| 3 | Ball | 12 | Intermediate plate | 33 | Rolled pin |
| 4 | Thread bushing | 13 | O-ring | 34 | Screw |
| 5 | Roto glyd ring | 14 | Distributor plate | 35 | Shock valve |
| 6 | Bearing assembly | 15 | Gearwheel set | 36 | Spring |
| 7 | Ring | 16 | End cover | 37 | O-ring |
| 8 | Cross pin | 17 | Washer | 38 | Plug |
| 9 | Set of spring | 18 | Screw with pin | 39 | Housing, check valve |

2) OPERATION

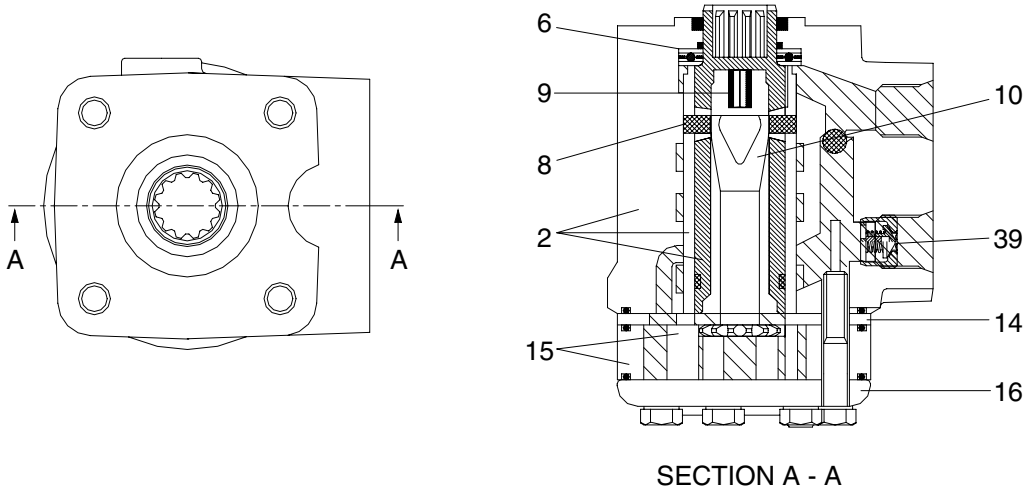

7407SE06

The steering unit consists of a rotary valve and a rotary meter.

Via a steering column the steering unit is connected to the steering wheel of the machine.

When the steering wheel is turned, oil is directed from the steering system pump via the rotary valve (spool and sleeve) and rotary meter (gear wheel set) to the cylinder ports L or R, depending on the direction of turn. The rotary meter meters the oil flow to the steering cylinder in proportion to the angular rotation of the steering wheel.

Spool is connected directly to the drive shaft (10) of steering wheel. It is connected to sleeve by cross pin (8) (not in contact with the spool when the steering wheel is at neutral) and neutral position spring (9).

Cardan shaft (10) is meshed at the top with cross pin (8) and forms one unit with sleeve.

At the same time, it is meshed with gear rim of the gerotor set by spline.

There are four ports in valve body. They are connected to the pump circuit, tank circuit, and the head, and left and right steering cylinder. In addition, the pump port and tank port are connected inside the body by the check valve. Therefore, if there is any failure in the pump of engine, oil can be sucked in directly from the tank through the check valve.

4. CUSHION VALVE

1) STRUCTURE

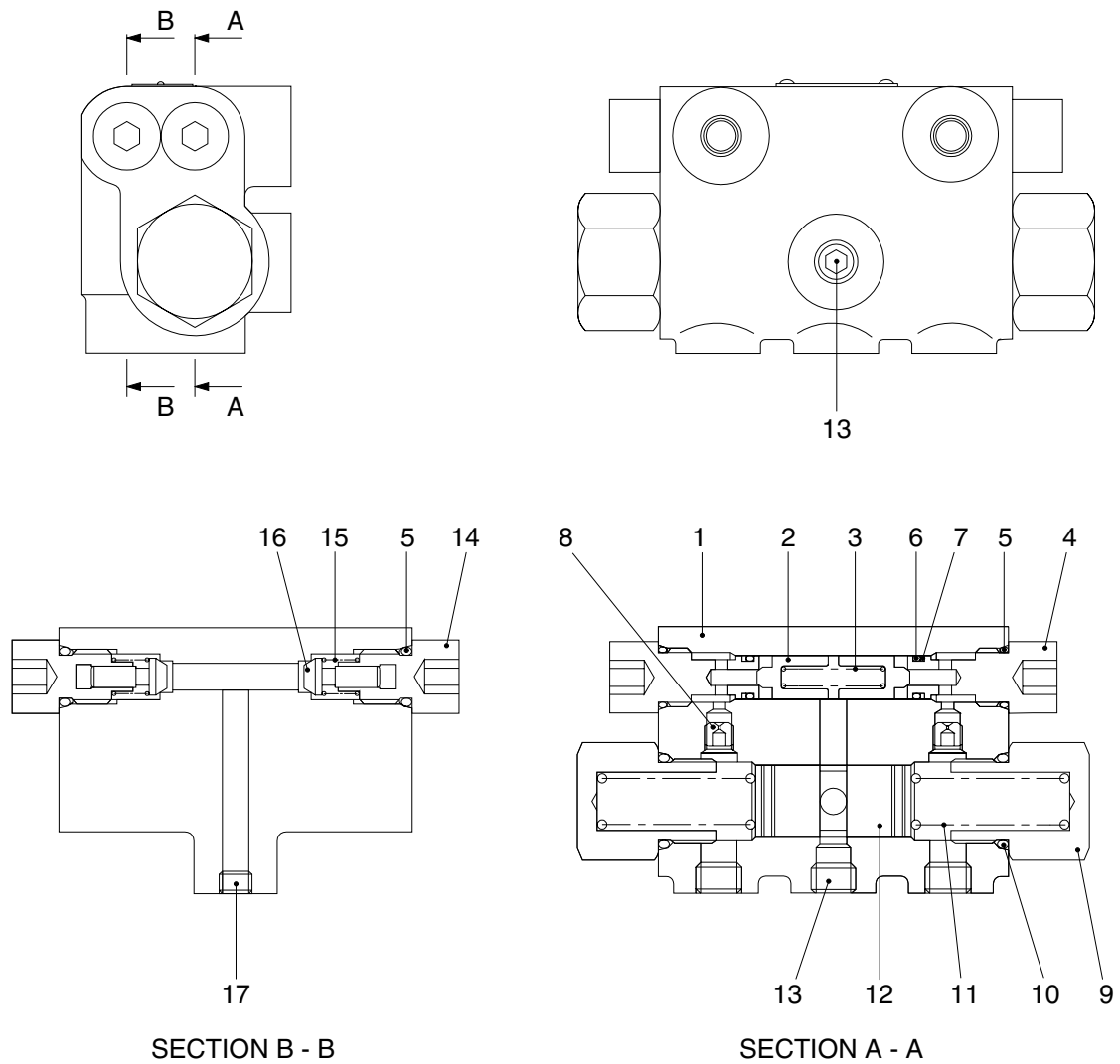

7607SE18

- | | | | | | |
|---|------------|----|-----------|----|--------|
| 1 | Housing | 7 | Back ring | 13 | Plug |
| 2 | Poppet | 8 | Orifice | 14 | Plug |
| 3 | Spring | 9 | Plug | 15 | Spring |
| 4 | Valve seat | 10 | O-ring | 16 | Poppet |
| 5 | O-ring | 11 | Spring | 17 | Plug |
| 6 | O-ring | 12 | Spool | | |

2) OPERATION

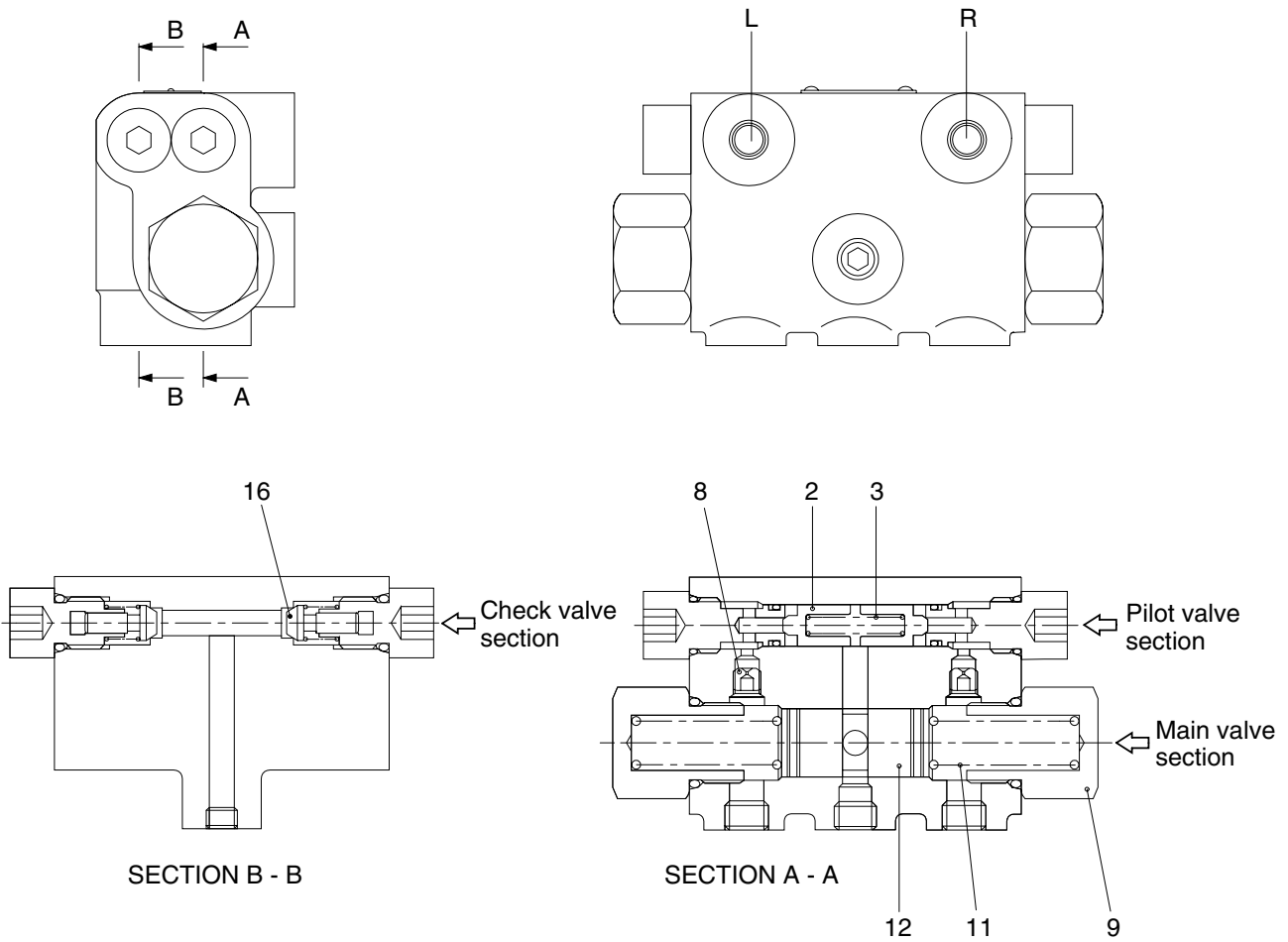

7607SE19

The cushion valve is a valve that eliminates steering jerk motion. It makes a higher pressurized oil to flow into another line in order to prevent the shock on steering system.

The pressure by rapid supplied pressurized oil from R port is higher than the spring (3) force, so it press and open the poppet (2). Then the oil flows to the central groove of the spool (12), and flows to L port through the poppet of the check valve (16) on L port side.

At this time, this pressurized oil flows to the pressure area of the plug (9) through the orifice (8), and this force is higher than the spring (11) force plus the oil pressure on L port side, so the spool (12) is shifted to the right. The flow of the supplied oil to L port side through the poppet (2) from R port side is trapped. The flow of this instant oil makes the function of the cushion. After this operation, the normal steering operation is not affected because this valve is not operated any longer.

Also, for the response of the pressure when the operation is slow as a cushion effect is not required, the spool (12) is closed before the poppet (2) is opened, so this valve is not operated.

5. STEERING CYLINDER

1) STRUCTURE

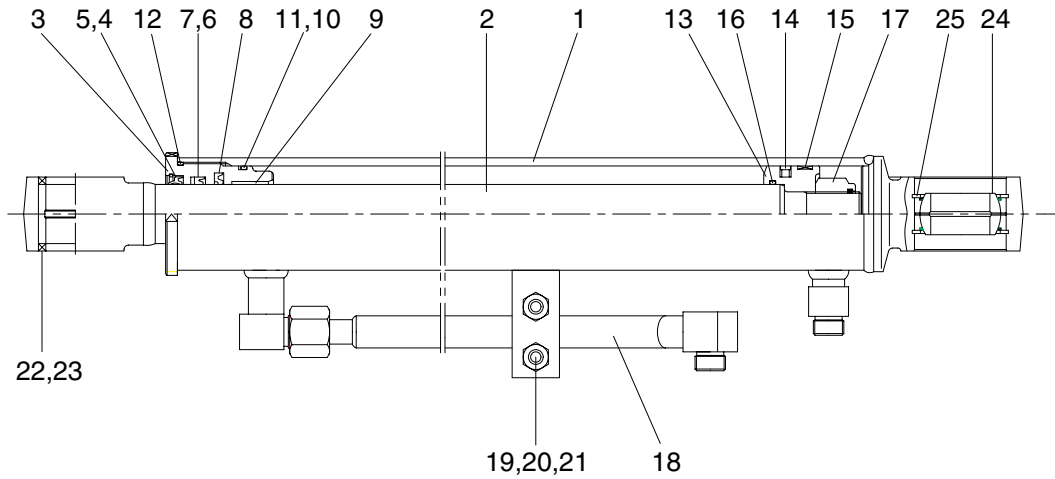

73095SE07

1	Tube assy	10	O-ring	19	U-bolt
2	Rod assy	11	Back up ring	20	Hexagon nut
3	Gland	12	O-ring	21	Spring washer
4	Dust wiper	13	Piston	22	Bushing
5	Retaining ring	14	Piston seal	23	Dust seal
6	Rod seal	15	Wear ring	24	Spherical bearing
7	Back up ring	16	O-ring	25	Retaining ring
8	Step seal	17	Nylon nut		
9	Du bushing	18	Pipe assy		

2) OPERATION

This machine use to cross connected cylinder for steering operation.

The steering cylinder use a gland (3) to remove piston and sealed seals. Dust wiper (4) located on the in side of the gland protects cylinder inner parts from dust. The piston (13) is fastened to the rod (2) by a nut (17).

The piston uses a single wear ring (15) with a piston seal (14) to seal between the piston and tube. The gland seals against the tube with two O-rings. The rod is sealed against the gland with a rod seal (6).