

GROUP 4 DISASSEMBLY AND ASSEMBLY

1. PRIORITY VALVE

1) STRUCTURE

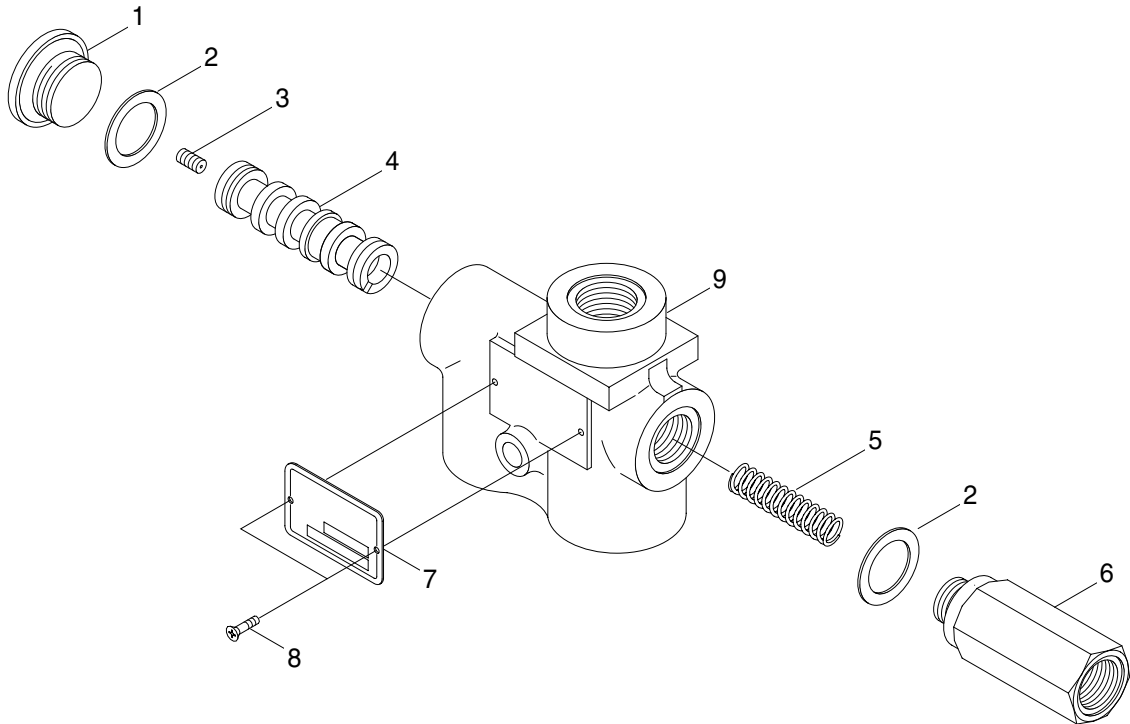

73035PR01

- | | | | | | |
|---|-----------|---|--------|---|-------------|
| 1 | Plug | 4 | Spool | 7 | Name plate |
| 2 | Seal ring | 5 | Spring | 8 | Drive screw |
| 3 | Orifice | 6 | Plug | 9 | Housing |

2) TOOLS

- Open-end spanner 22mm.
- Nylon pin.
- Hexagon socket spanner 8mm.
- Torque wrench.
- Socket spanner 22mm.
- Hexagon socket spanner insert 8mm.

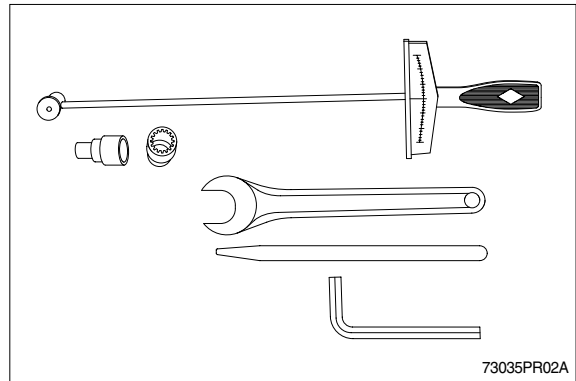

3) DISASSEMBLY

- ※ Cleanliness is the primary means of assuring satisfactory the priority valve life. Select clean place. Before removing the piping, clean the surrounding area of valve ports.

- (1) Screw out the PP plug using the 8mm hexagon socket spanner. Remove the seal ring.

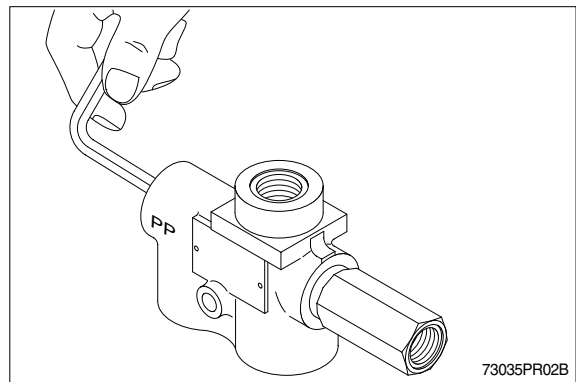

- (2) Loosen the LS plug using the 22mm open-end spanner.

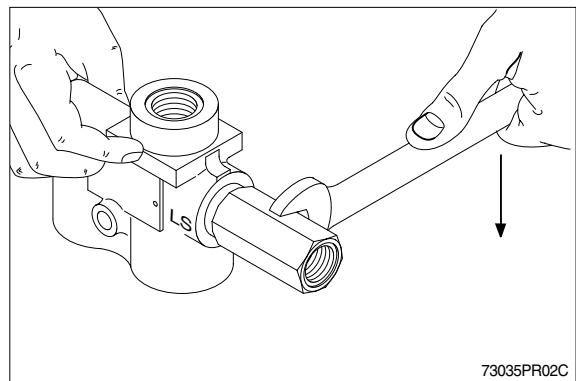

(3) Pull out the plug with seal ring and spring.

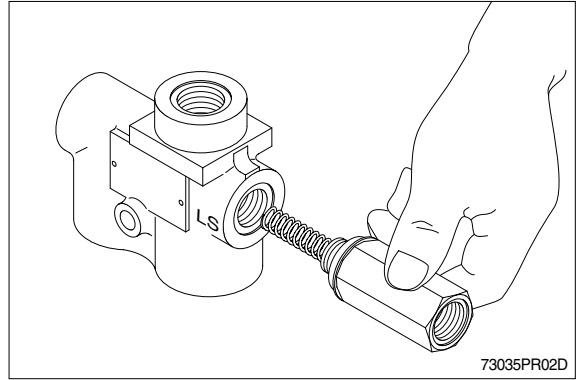

(4) Press out the spool using the nylon pin.

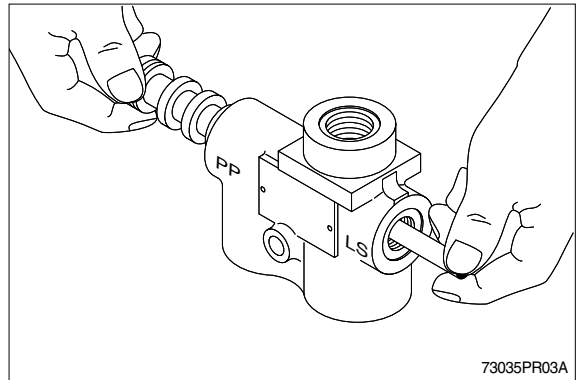

(5) Disassembled priority valve.

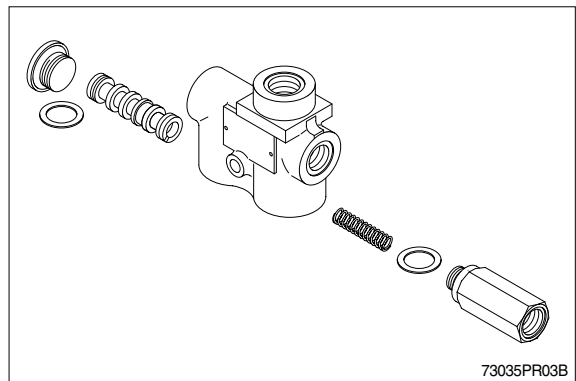

4) MODIFICATION

- (1) The control spring pressure can be altered by replacing the spring(See table below). Replace name plate so that code no. and control spring pressure match each other again.

Control spring pressure(bar)	d(mm)	Di(mm)	L(mm)
4	1.8	6.9	54
7	2.0	6.5	55

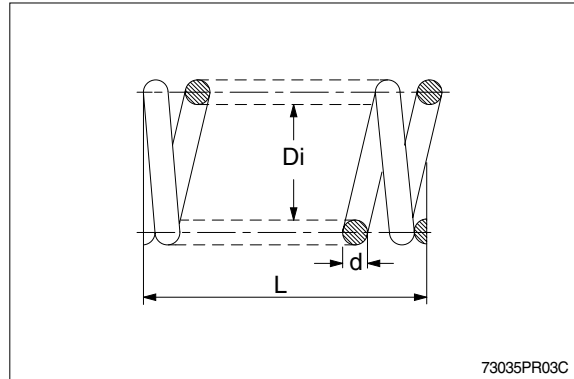

(2) Cleaning

Clean all parts carefully in low aromatic kerosene.

(3) Inspection and replacement

Check all parts carefully and make any replacements necessary. All seal rings must be replaced.

(4) Lubrication

Before assembly, lubricate all parts with hydraulic oil.

5) ASSEMBLY

- (1) Guide the spool into the bore. Use the nylon pin to center the spool in the bore.

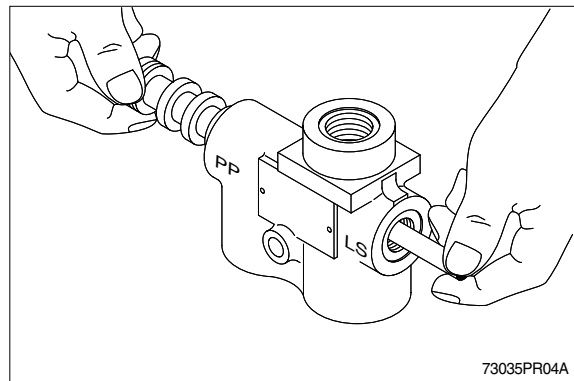

- (2) Put in the PP plug.
Remember seal ring.

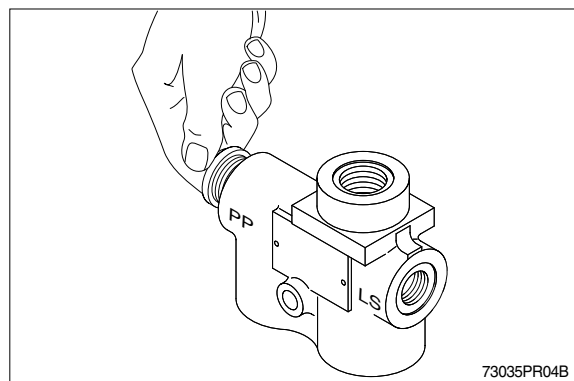

- (3) Guide the spring and LS plug into the bore.
Remember seal ring.

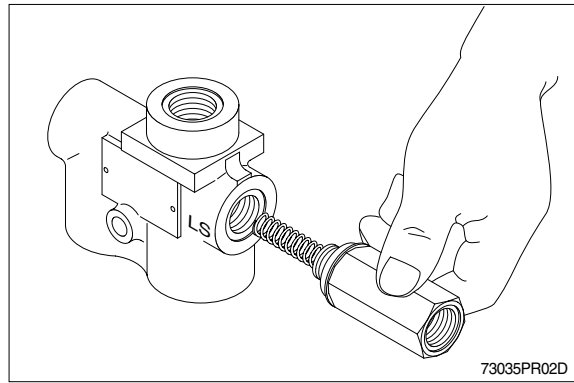

- (4) Tighten the LS plug with torque wrench using a 22 socket spanner insert.
· Tighten torque : $5.1 \pm 1 \text{kgf} \cdot \text{m}$
($36.9 \pm 7.2 \text{lbf} \cdot \text{ft}$)

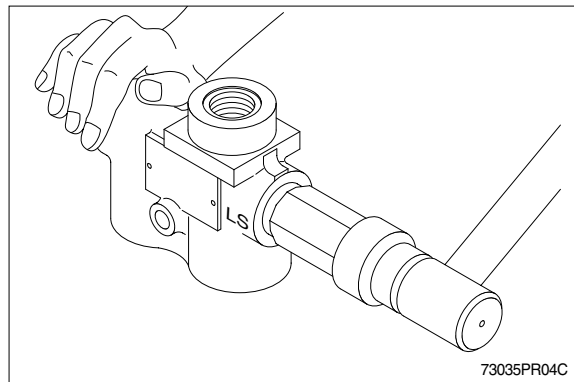

- (5) Tighten the PP plug with a torque wrench using a 8mm hexagon socket spanner insert.
· Tighten torque : $5.1 \pm 1 \text{kgf} \cdot \text{m}$
($36.9 \pm 7.2 \text{lbf} \cdot \text{ft}$)

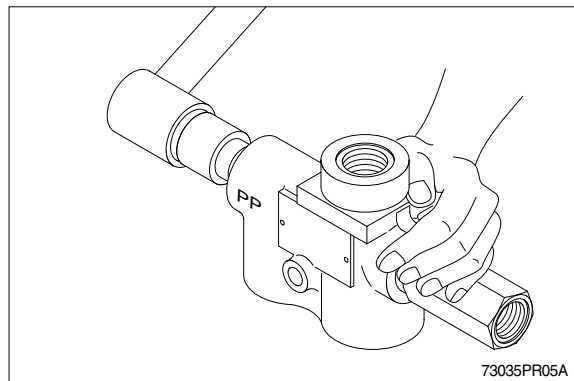

- (6) The priority valve is now assembled.

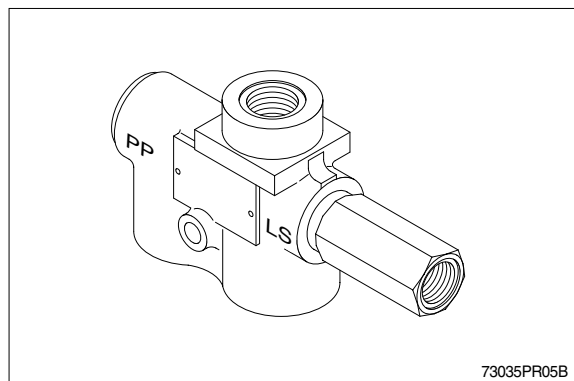

6) TROUBLESHOOTING

Problem	Cause	Remedy
<p>Steering wheel is heavy</p> <p>(Steering wheel is heavy at engine low idle)</p> <p>(Steering speed is not high at engine high idle)</p>	<ol style="list-style-type: none"> 1. Relief valve of steering unit is clogged with dirt. 2. Spool is stuck. 3. Orifice of plug and spool is clogged. <ol style="list-style-type: none"> a. Pump is faulty. b. Control pressure is low. c. Piping is faulty. d. Pump is faulty. 	<p>Disassembly, clean and reassembly.</p> <p>Disassembly, clean and reassembly or replace.</p> <p>Disassembly, clean and reassembly.</p> <p>Check pump.</p> <p>Reset control pressure.</p> <p>Replace piping.</p> <p>Check pump.</p>
Abnormal noise	<ol style="list-style-type: none"> 1. Relief valve of steering unit is clogged with dirt. 2. Spool is stuck. 	<p>Disassembly, clean and reassembly.</p> <p>Disassembly, clean and reassembly or replace.</p>
Leakage	<ol style="list-style-type: none"> 1. Loosen the plug. 2. O-ring is damaged. 	<p>Retighten the specified torque.</p> <p>Replace.</p>

2. STEERING UNIT

1) STRUCTURE

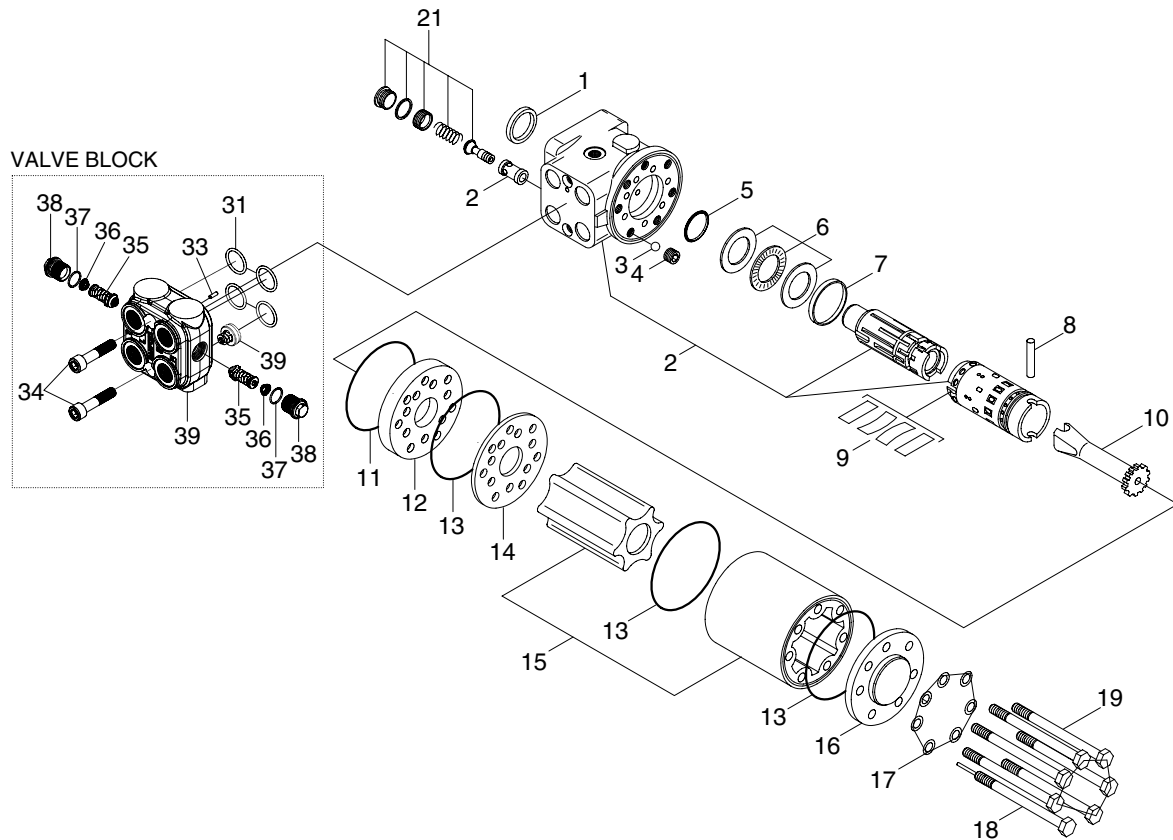

7407SE11

1	Dust seal ring	11	O-ring	21	Complete relief valve without seat
2	Housing, spool, sleeve	12	Intermediate plate	31	Set of o-rings
3	Ball	13	O-ring	33	Rolled pin
4	Thread bushing	14	Distributor plate	34	Screw
5	Roto glyd ring	15	Gearwheel set	35	Shock valve
6	Bearing assembly	16	End cover	36	Spring
7	Ring	17	Washer	37	O-ring
8	Cross pin	18	Screw with pin	38	Plug
9	Set of spring	19	Screw	39	Housing, check valve
10	Cardan shaft				

2) TOOLS

(1) Holding tool.

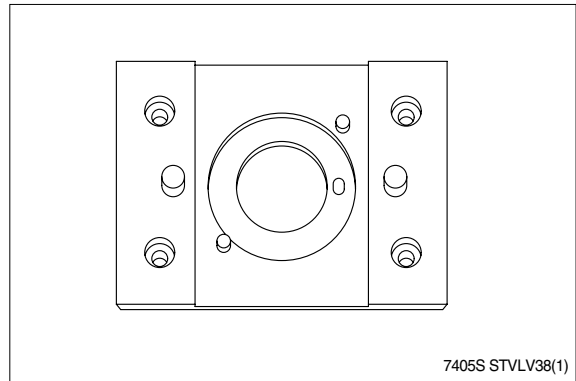

(2) Assembly tool for O-ring and kin-ring.

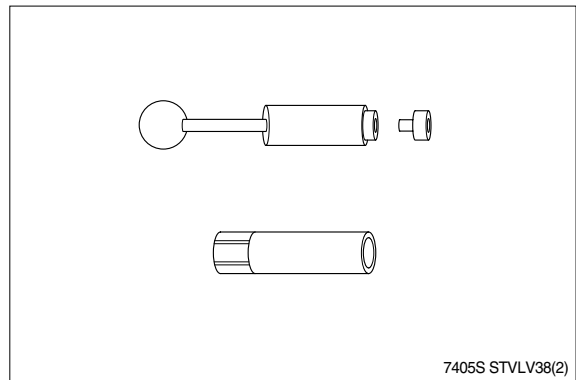

(3) Assembly tool for dust seal.

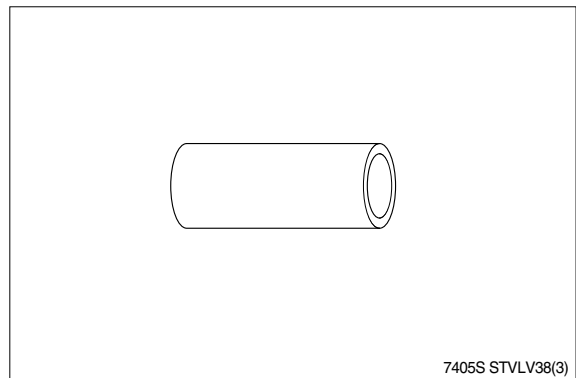

(4) Torque wrench 0-7.1kgf · m(0-51.6lb · ft).

13mm socket spanner

12mm screwdriver

6mm screwdriver

2mm screwdriver

Plastic hammer

Ratchet spanner

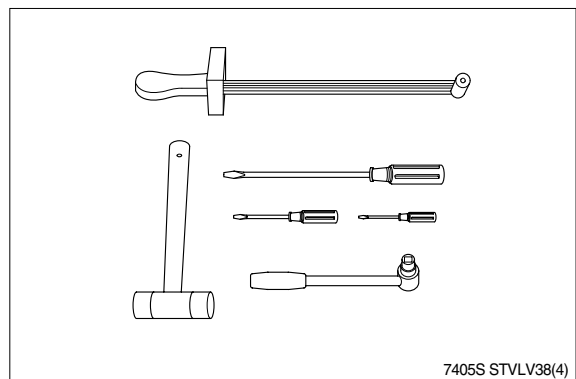

3) DISASSEMBLY

- (1) Disassemble steering column from steering unit and place the steering unit in the holding tool. Screw out the screws in the end cover(7-off-one rolled pin).

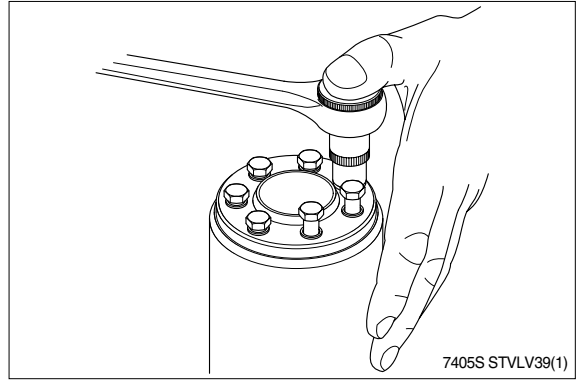

- (2) Remove the end cover, sideways.

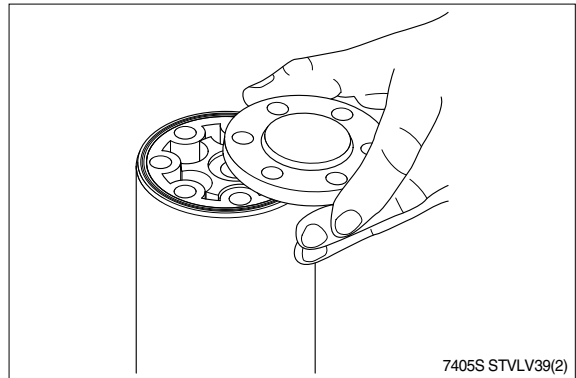

- (3) Lift the gearwheel set with spacer bushing(and spacer if fitted) off the unit. Take out the two O-rings.

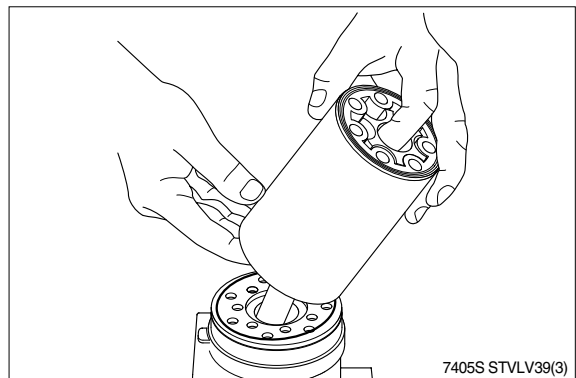

- (4) Remove spacer bushing and spacer(if fitted) from the gearwheel.

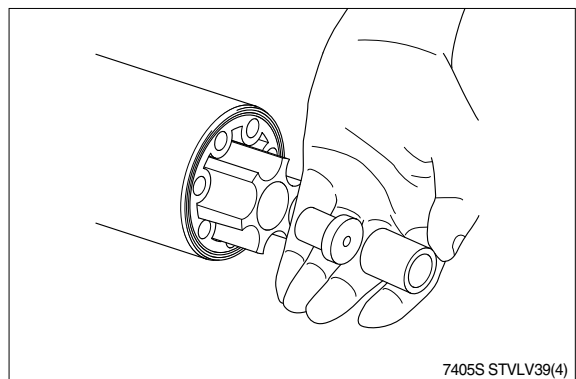

(5) Remove cardan shaft.

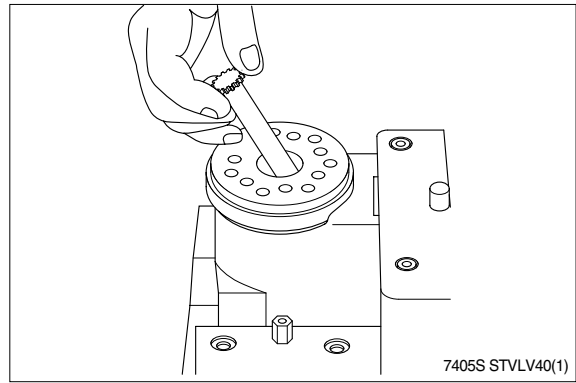

(6) Remove distributor plate.

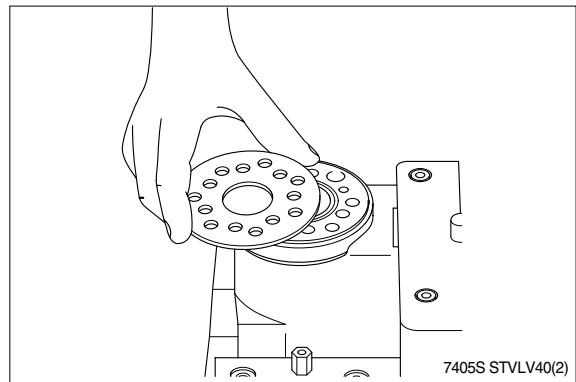

(7) Remove O-ring.

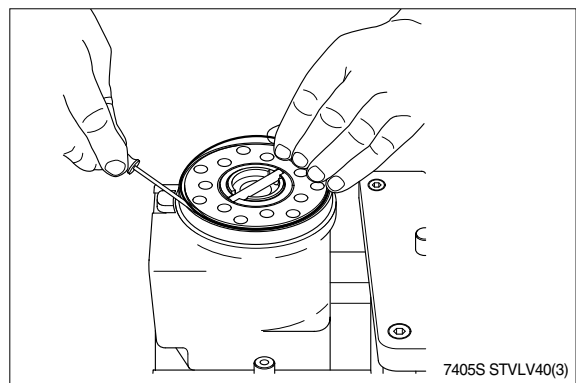

(8) Lift off intermediate plate.

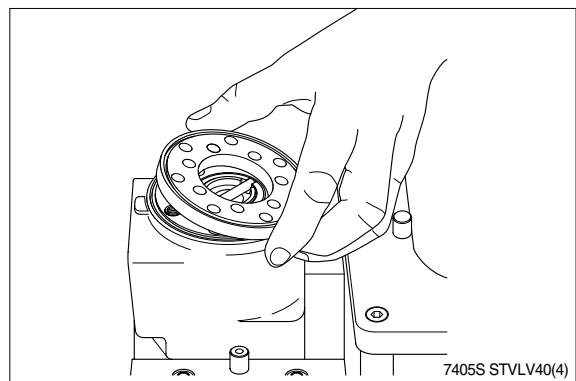

(9) Remove O-ring.

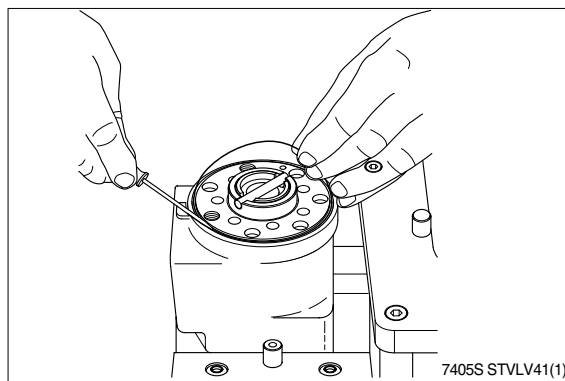

(10) Screw out the threaded bushing.

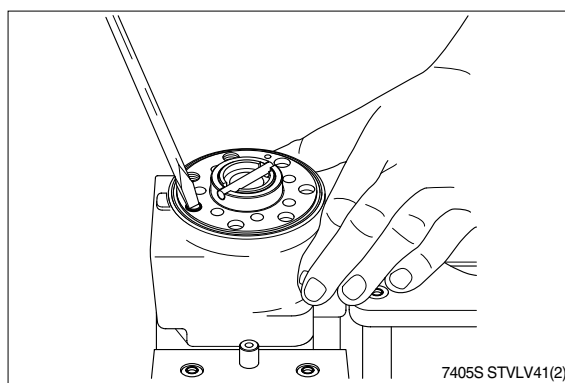

(11) Remove cross pin.

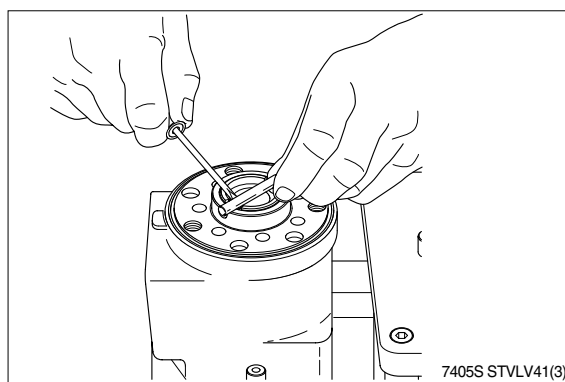

(12) Shake out the ball(\varnothing 8.5mm).

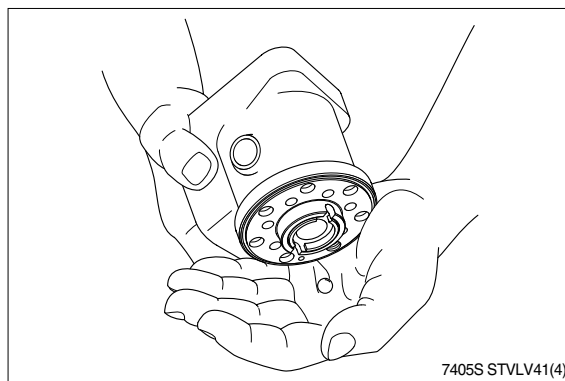

(13) Pull sleeve and spool out of the housing.

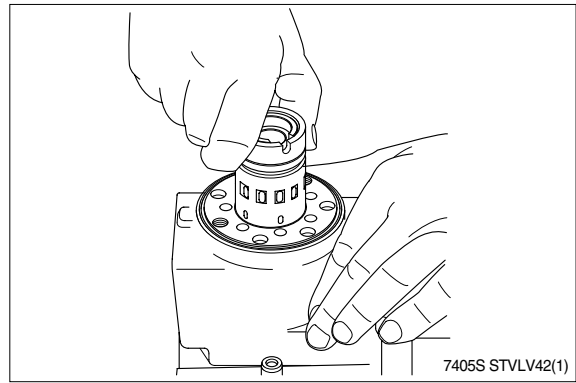

(14) Take ring, bearing races and needle bearing from sleeve and spool. The outer(thin) bearing race can sometimes "stick" in the housing, therefore check that it has come out.

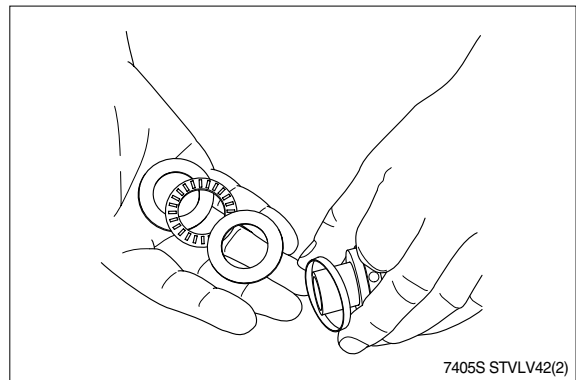

(15) Carefully pull the spool out of the sleeve.

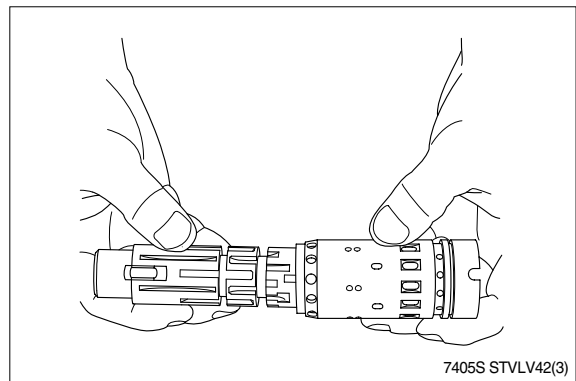

(16) Press the neutral position springs out of their slots in the spool.

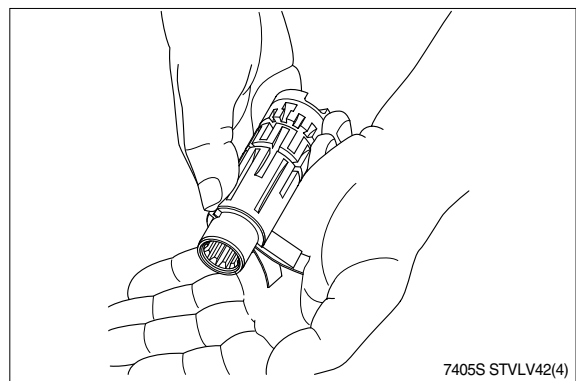

(17) Remove dust seal and O-ring.

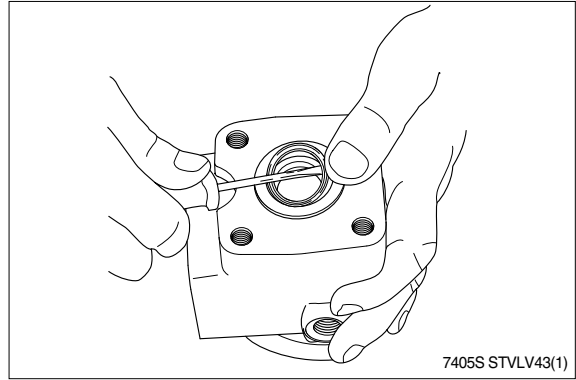

(18) The steering unit is now completely disassembled.

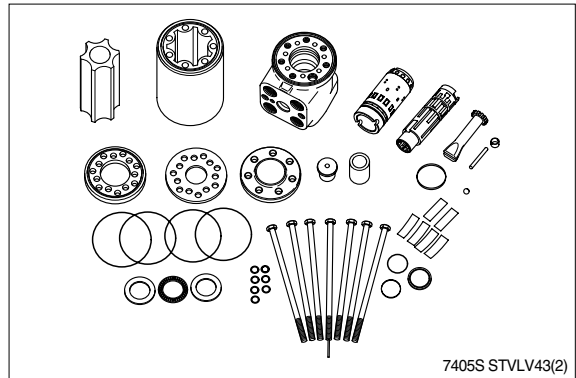

Cleaning

Clamp all parts carefully in Shellsol K or the like.

Inspection an replacement

Replace all seals and washer. Check all parts carefully and make any replacements necessary.

Lubrication

Before assembly, lubricate all parts with hydraulic oil.

4) ASSEMBLY

(1) Assemble spool and sleeve.

※ The sleeve and spool are correctly assembled when

- ① The slots-in sleeve and spool-for the neutral position springs are opposite each other and
- ② One of the 3 T-shaped grooves(A) in the spool is opposite one of the sets(B) of small holes in the sleeve.

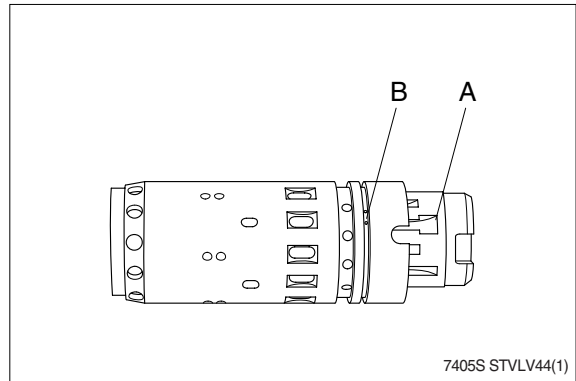

(2) Place the two flat neutral position springs in the slot.

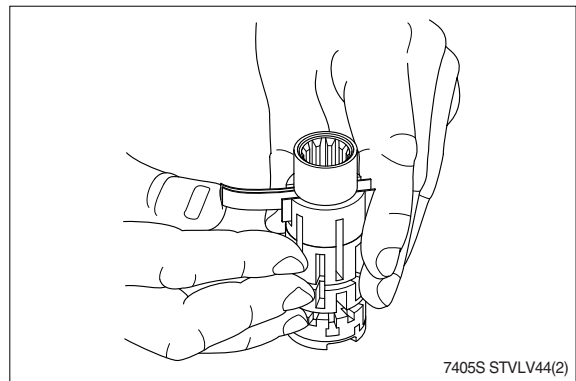

(3) Place the curved springs between the flat ones and press them into place.

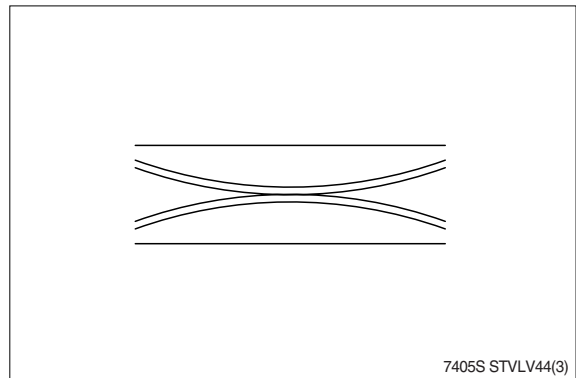

(4) Line up the spring set.

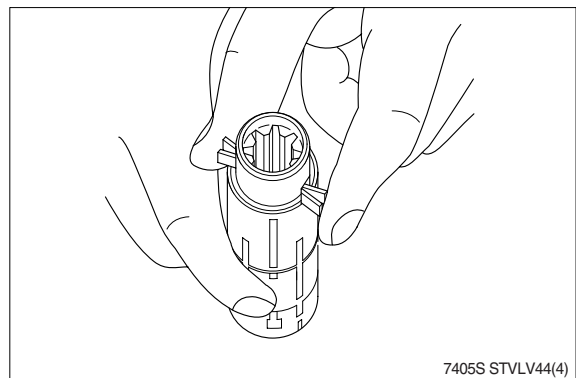

(5) Guide the spool into the sleeve.

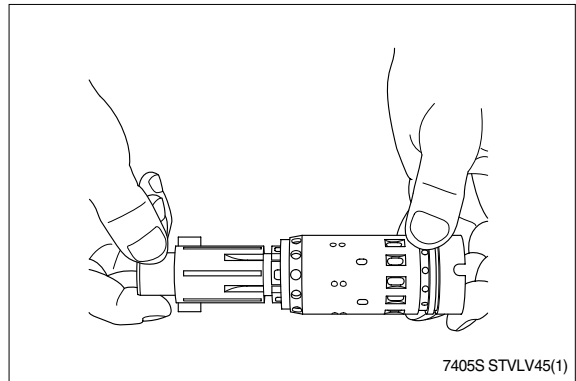

(6) Press the springs together and push the neutral position springs into place in the sleeve.

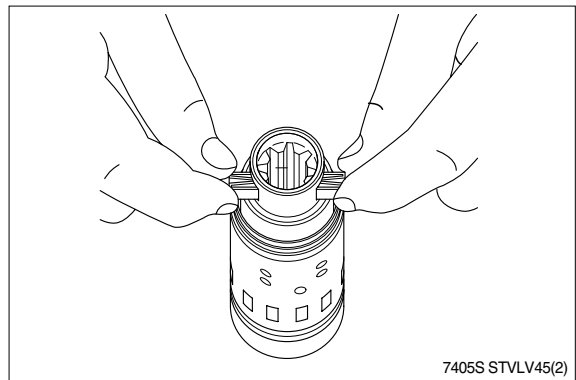

(7) Line up the springs and center them.

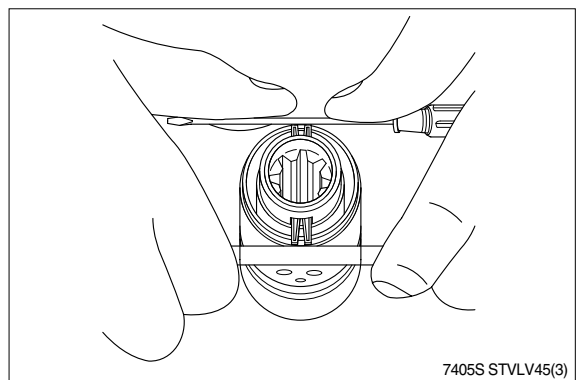

(8) Guide the ring down over the sleeve.
※ The ring should be able to rotate-free of the springs.

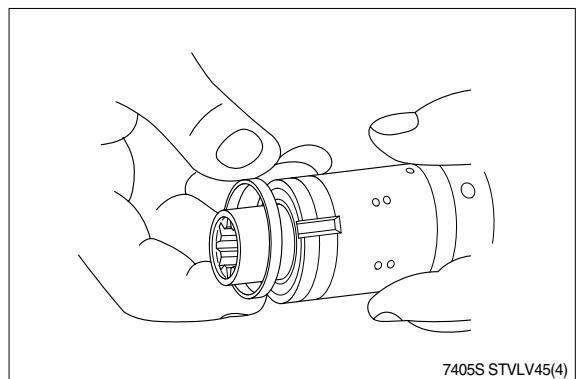

(9) Fit the cross pin into the spool/sleeve.

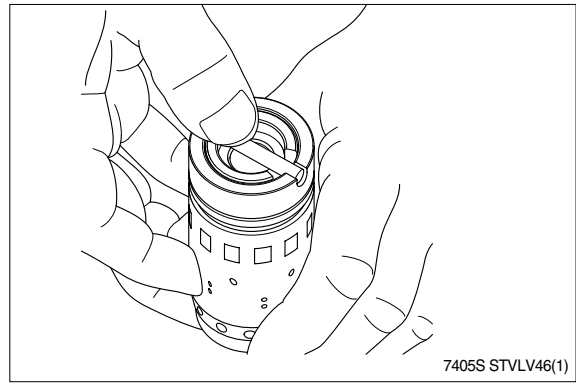

(10) Fit bearing races and needle bearing as shown on below drawing.

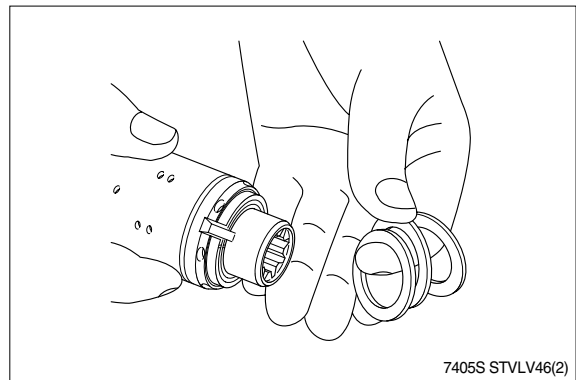

- 1 Outer bearing race
- 2 Needle bearing
- 3 Inner bearing race
- 4 Spool
- 5 Sleeve
- * Inside chamfer on inner bearing race must face inner spool.

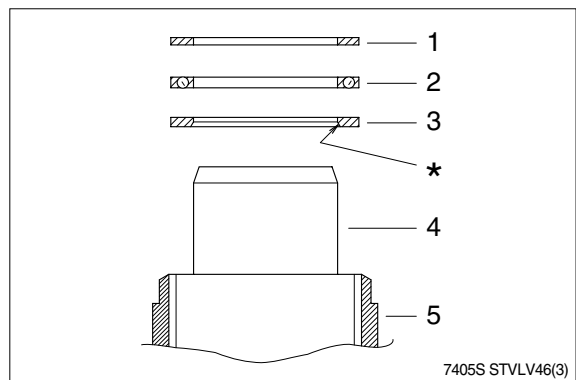

(11) Grease O-ring and kin-ring with hydraulic oil and place them on the tool. See next page.

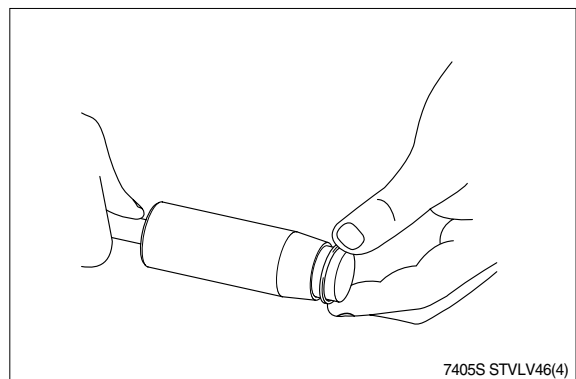

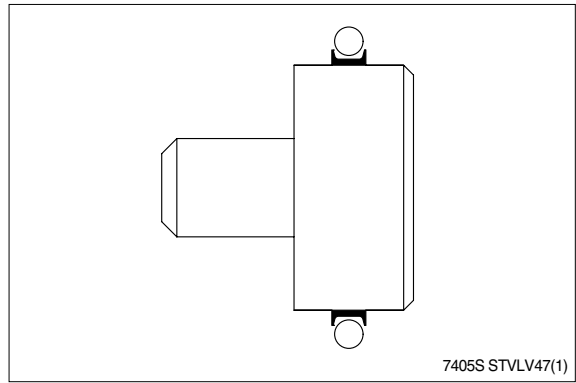

- (12) Put the steering unit in the holding tool keeping the bore vertical. Guide the outer part of the assembly tool into the bore. Guide the inner part of the tool right to the bottom.

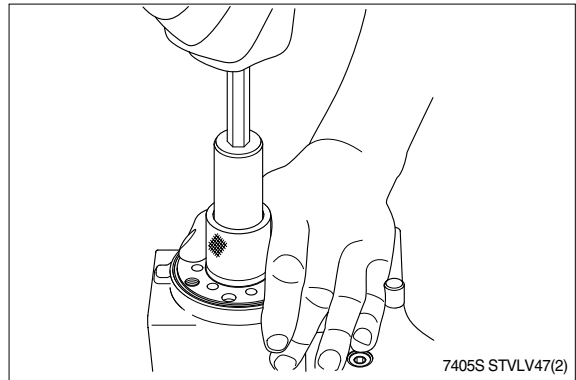

- (13) Press and turn the O-ring into position in the housing. Draw the inner and outer parts of the assembly tool out of the steering unit bore, leaving the guide in the bore.

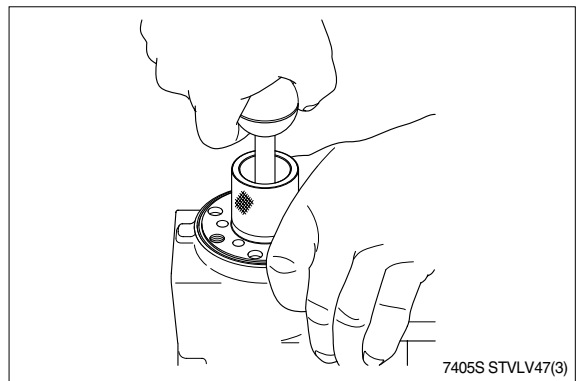

- (14) Take the steering unit out of the holding tool and place it horizontally. With a light turning movement, guide the spool and sleeve into the bore.

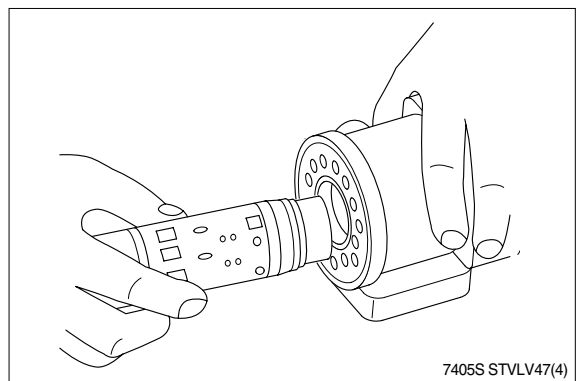

(15) The spool set will push out the assembly tool guide. The O-ring is now in position.

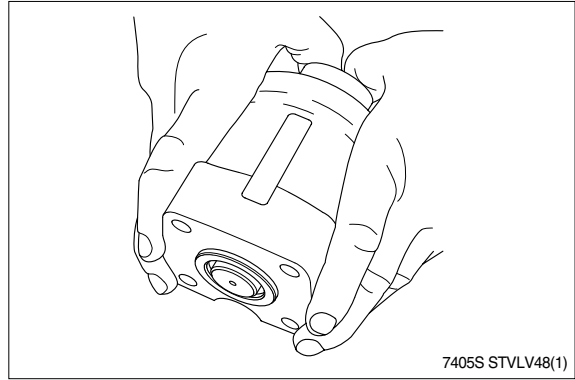

(16) Put the steering unit back into the holding tool keeping the bore vertical. Place the cross pin in the spool/sleeve so that it is parallel to the port flange.

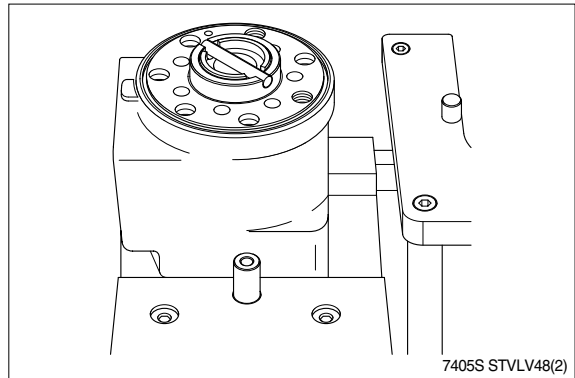

(17) Put the ball into the hole indicated by the arrow.

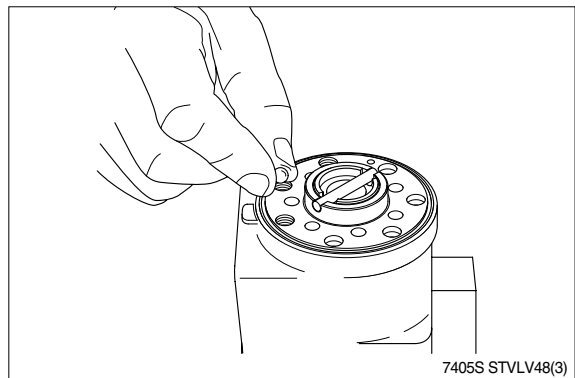

(18) Screw the threaded bushing lightly into the bore. The top of the bushing must lie just below the surface of the housing.

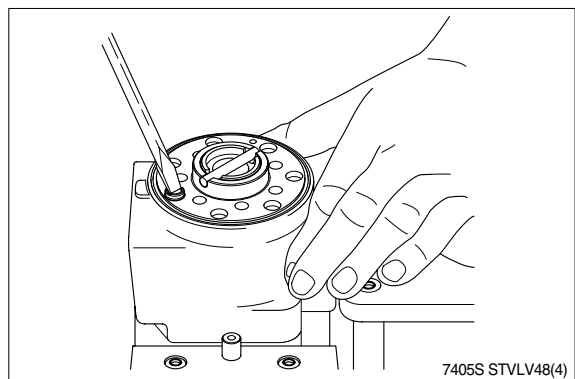

- (19) Grease the O-ring with mineral oil approximate viscosity 500 cSt at 20°C and place it in the groove.

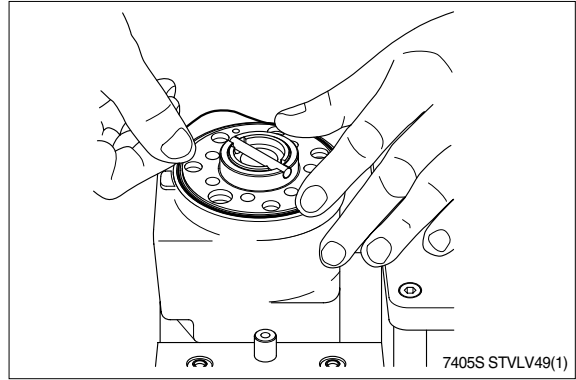

- (20) Place the intermediate plate so that the channel holes match the holes in the housing.

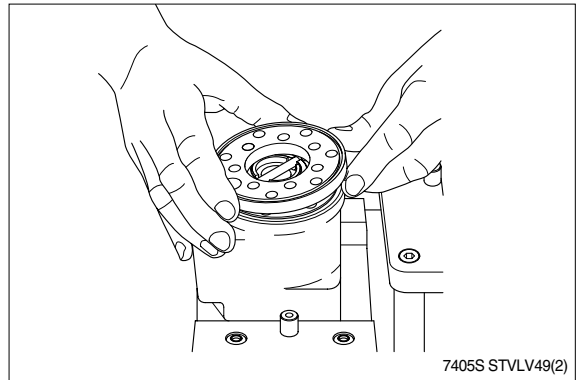

- (21) Grease the O-ring with mineral oil approximate viscosity 500 cSt at 20°C and place it in the groove.

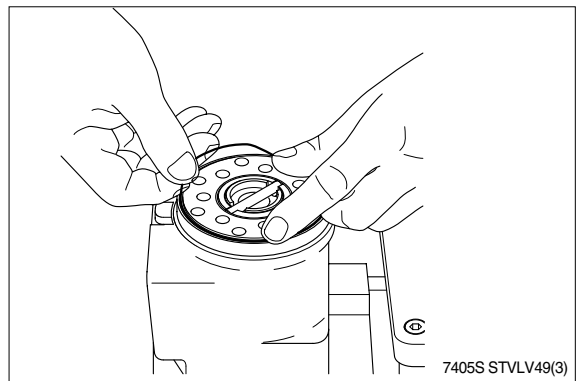

- (22) Place the distributor plate so that the channel holes match the holes in the intermediate plate and the housing.

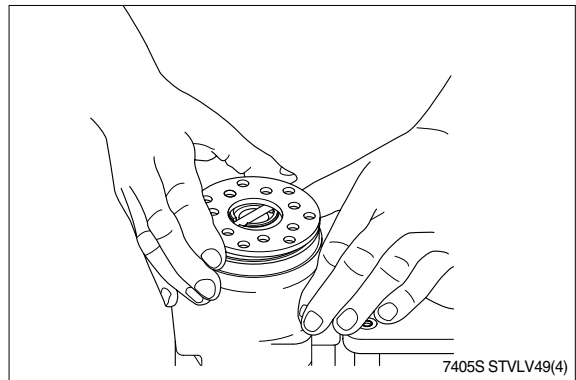

- (23) Guide the cardan shaft down into the bore so that the slot is parallel with the connection flange.

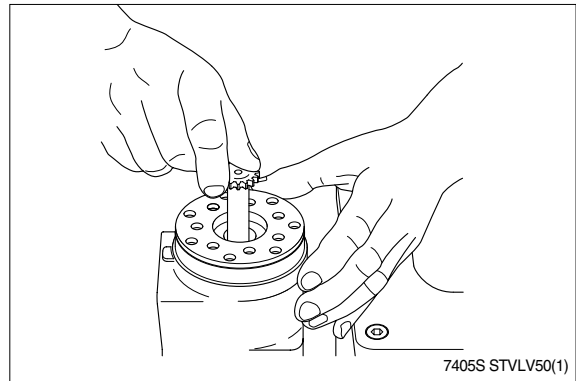

- (24) Place the gear wheel(Rotor) so that the cross pin from item 33 is positioned in relation to two tooth bases - as the screw driver indicates.

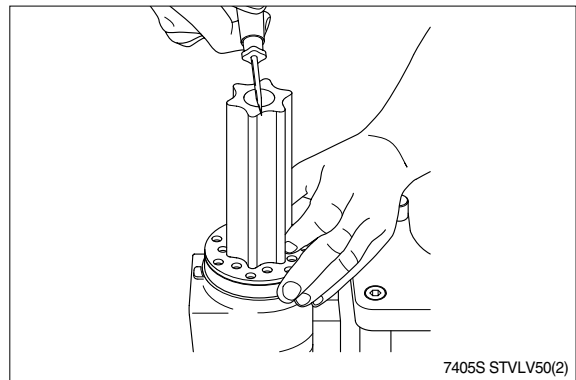

- (25) Grease the two O-rings with mineral oil approximate viscosity 500 cSt at 20°C and place them in the two grooves in the gear rim. Fit the gear rim so that the seven through holes match the holes in the distributor plate.

- ※ Turn the gear rim so that the smaller diameter of the holes face the distributor plate.

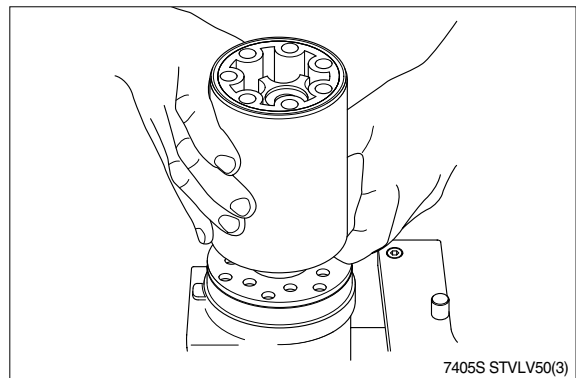

- (26) Orientate the holes with a single screw.

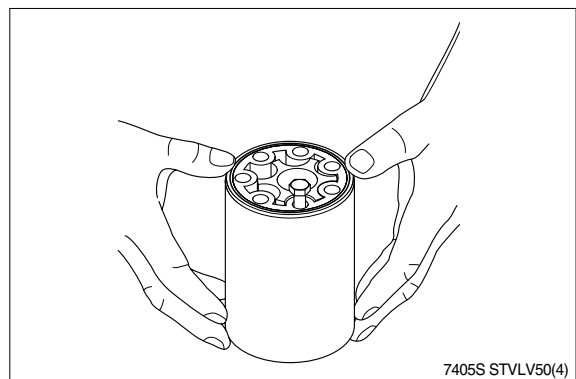

(27) Place the end cover in position.

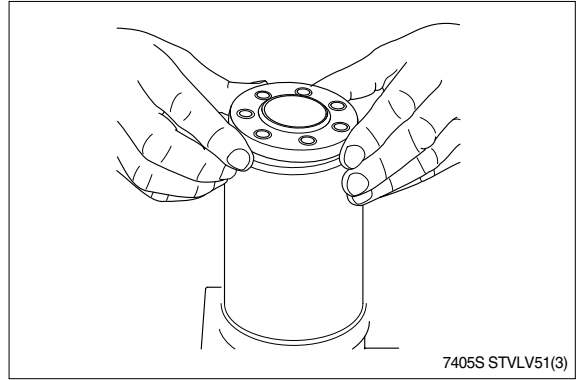

(28) Place the washers over the holes and the rolled pin in the hole shown.

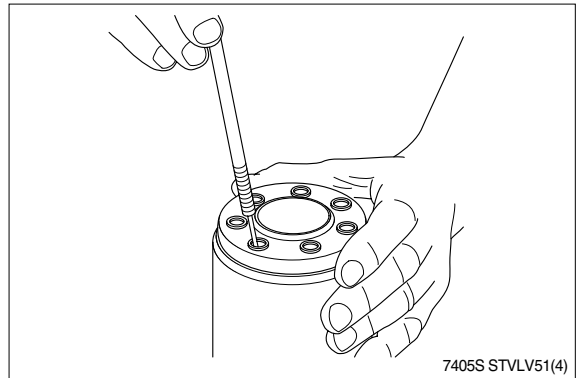

(29) Fit the other six screws. Cross - tighten all the screws and the rolled pin with a torque of $3 \pm 0.6 \text{ kgf} \cdot \text{m}$ ($22 \pm 4.4 \text{ lb} \cdot \text{ft}$). Steering unit can now be function tested.

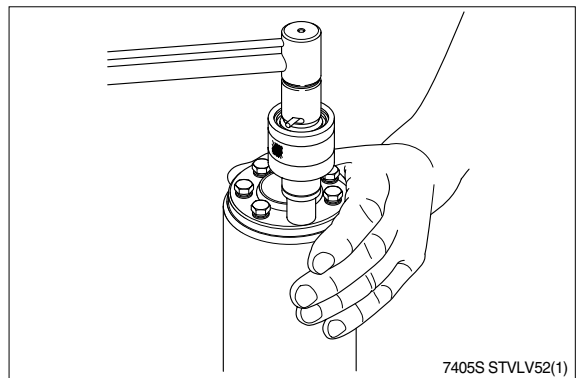

(30) Turn the steering unit 180° and place the dust seal ring in the housing.

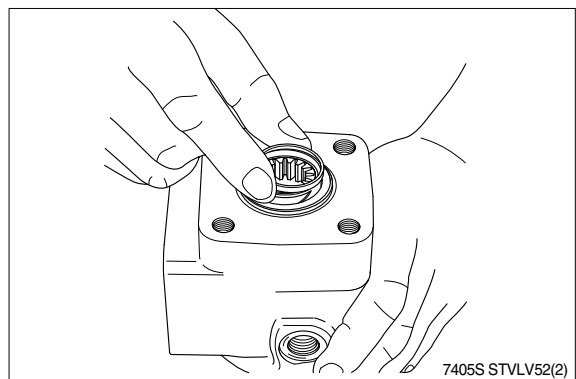

(31) Fit the dust seal ring in the housing using special tool and a plastic hammer.

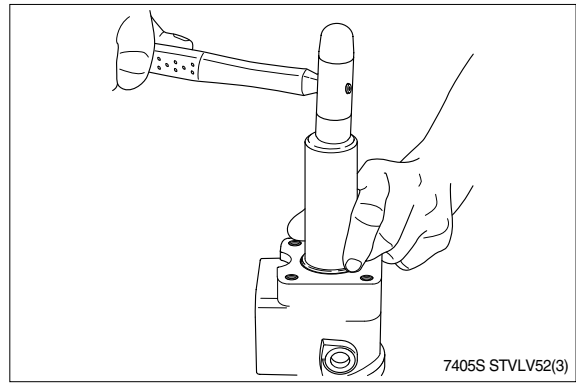

(32) Press the plastic plugs into the connection ports. Do not use a hammer.

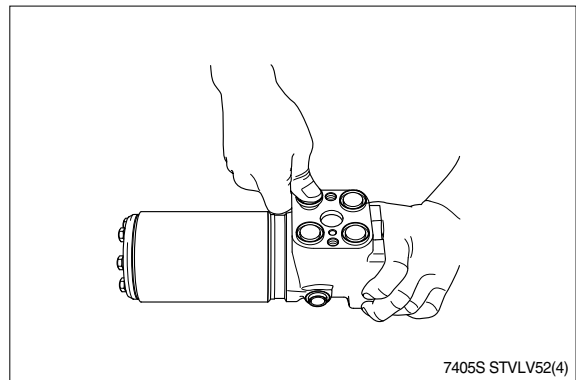

3. VALVE BLOCK

1) STRUCTURE

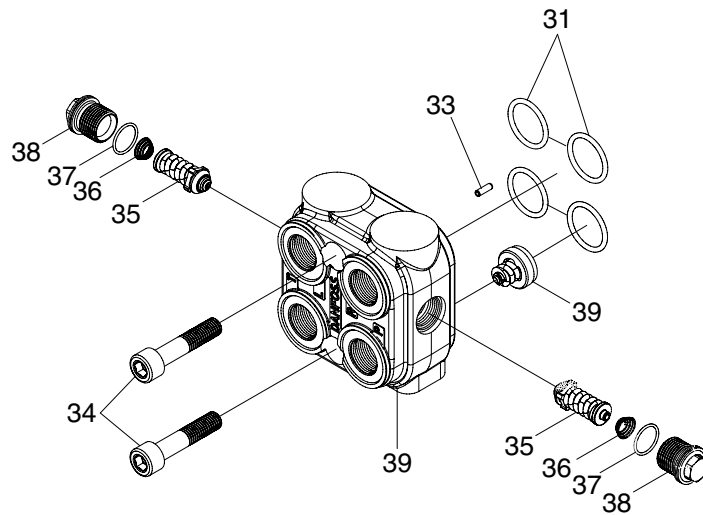

P,T,L,R port	PF 1/2
Shock valves	270-290 bar

- 31 Set of springs
- 33 Rolled pin
- 34 Screw
- 35 Shock valve

- 36 Spring
- 37 O-ring
- 38 Plug
- 39 Housing and check valve

7407SE12

2) TOOLS

(1) Hexagon socket spanner, 8mm.

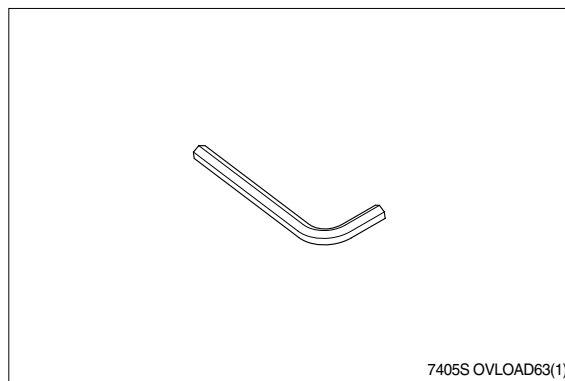

(2) Torque wrench, 0~7.1kgf · m(0~51lb · ft)
with 8mm hexagon socket spanner.

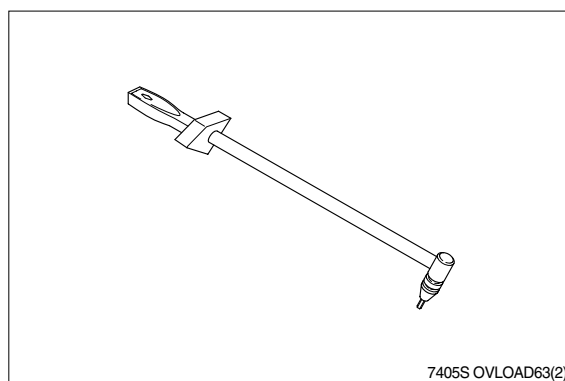

(3) Adjustable wrench.

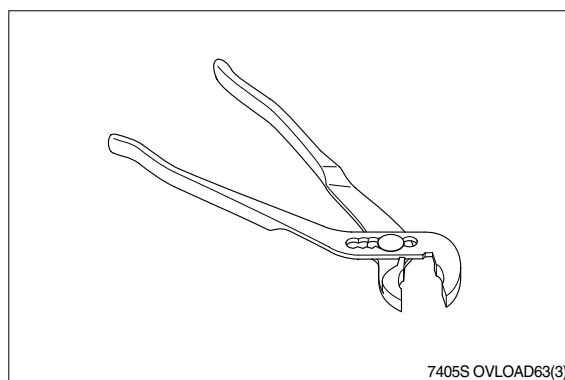

3) DISASSEMBLY

(1) Remove the rolled pin.

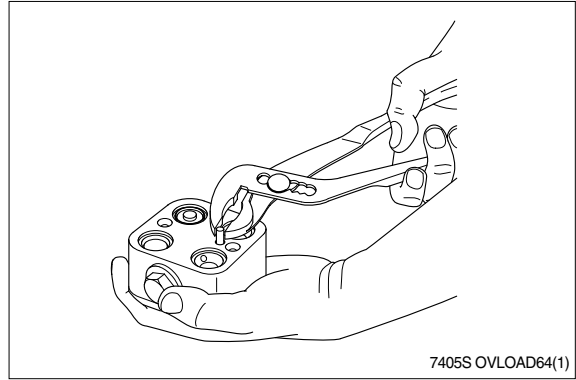

(2) Remove the plug(38) and O-ring(37).

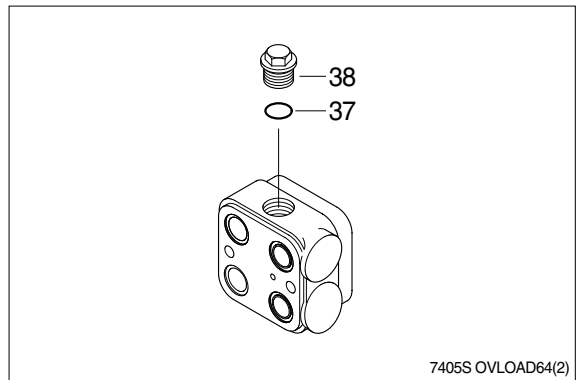

(3) Remove the spring(36) and shock valve(35).

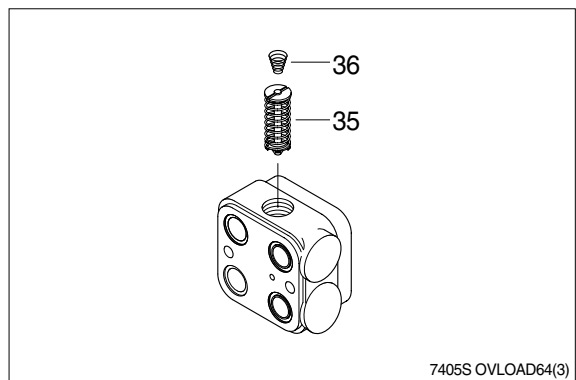

(4) Remove the O-ring set(31).

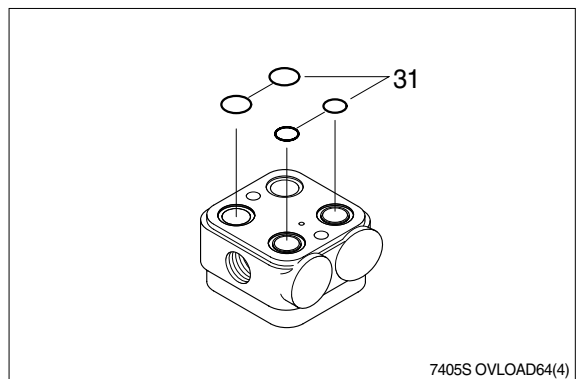

(5) Remove the check valve(39).

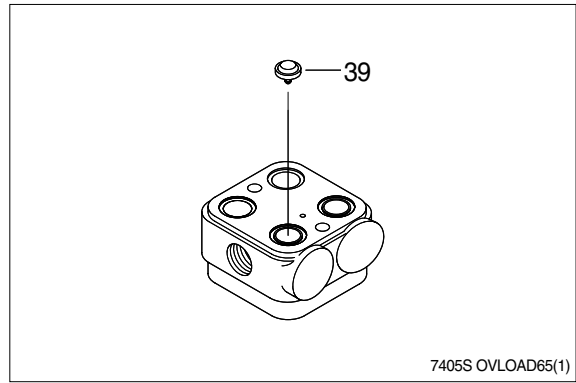

(6) The overload valve is now disassembled.

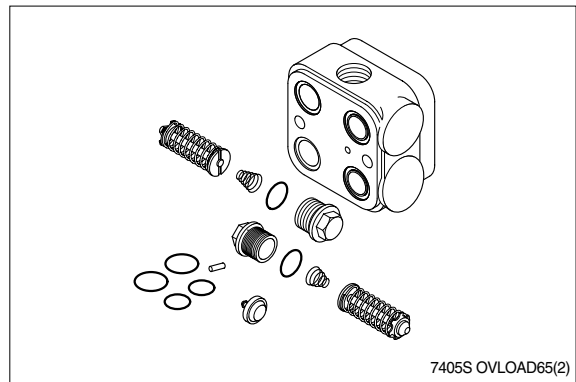

4) ASSEMBLY

Cleaning

Clean all parts carefully in Shellsol K or the like.

Inspection an replacement

Replace all seals and washers. Check all parts carefully and make any replacements necessary.

Lubrication

Before assembly, lubricate all parts with hydraulic oil.

(1) Fit check valve(39).

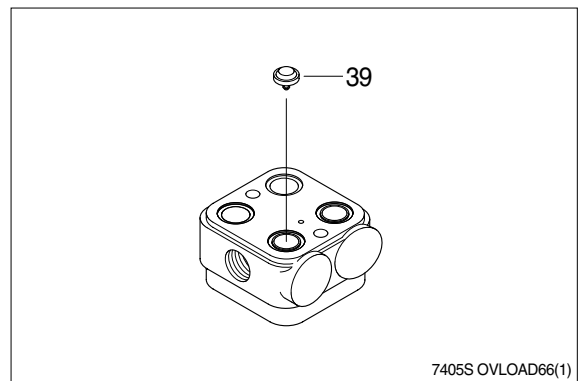

(2) Fit the shock valve(35) and spring(36).

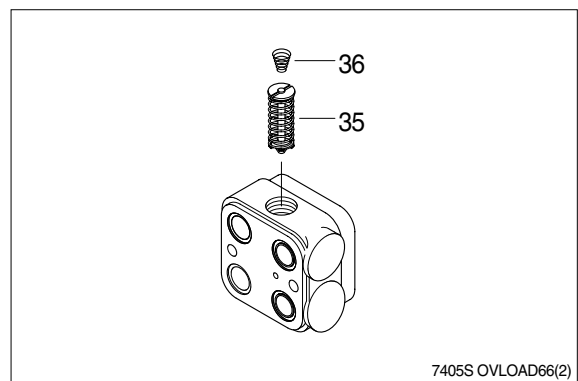

(3) Fit the O-ring(37) and screw the plug(38).

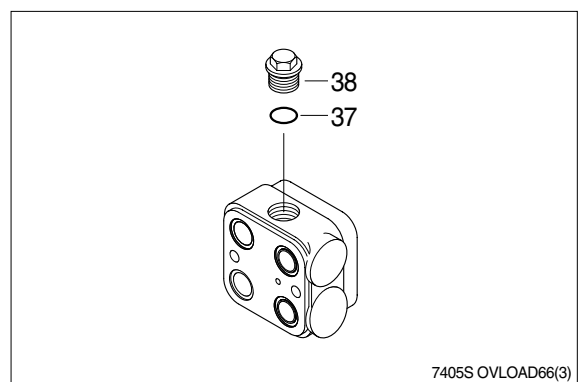

(4) Fit the rolled pin.

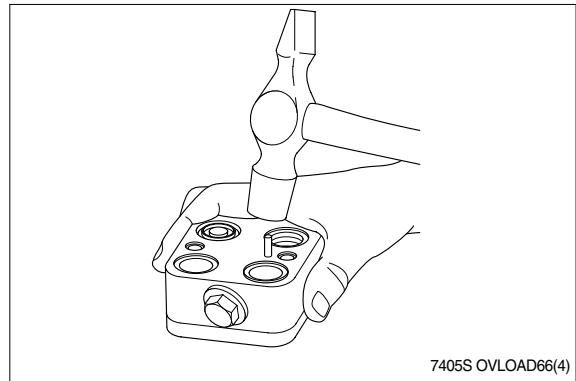

(5) The overload valve is now assembled. It can be checked for leakage separately or when mounted on a steering unit.

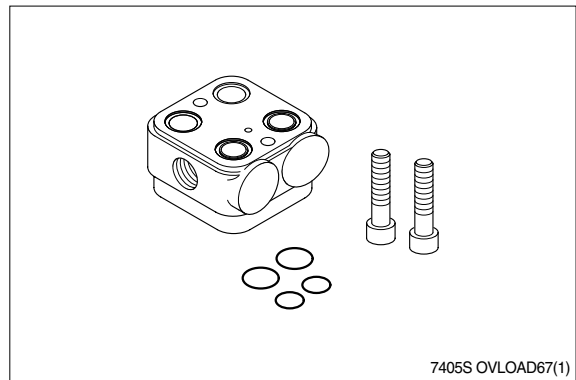

(6) Locate the four O-rings between overload valve and steering unit and fit these components together.

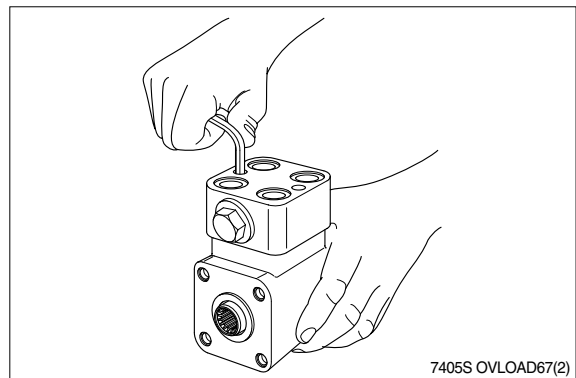

(7) Tighten the hexagon socket screws with a torque of $6.6^{+0.5}_0$ kgf · m ($47.7^{+3.6}_0$ lb · ft).

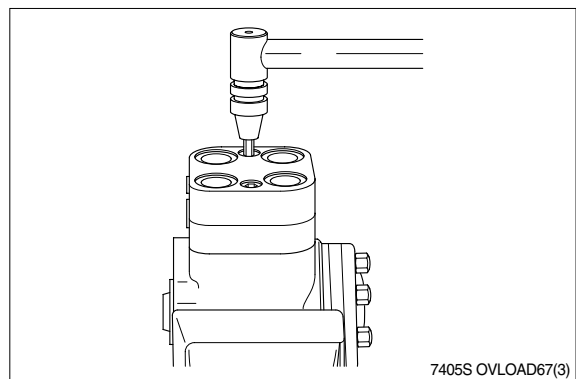

(8) Press the plastic plugs into the connection ports. The overload valve is now assembled.

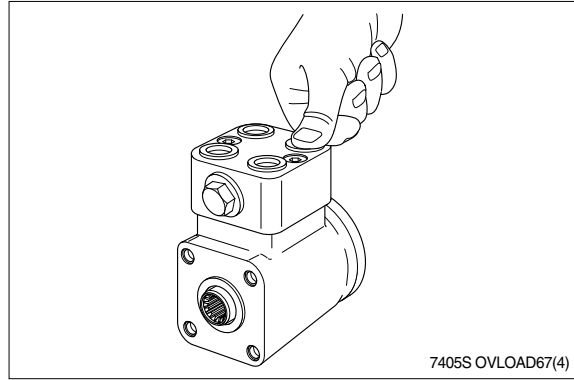

5) TROUBLESHOOTING

Problem	Cause	Remedy
Steering wheel is heavy	<ol style="list-style-type: none"> 1. Over tighten mounting torque. 2. Over load valve seat side is clogged with dirt. 	<p>Retighten as specified torque.</p> <p>Disassembly, clean, reassembly.</p>
Steering cylinder reaction is bad	<ol style="list-style-type: none"> 1. Overload valve seat side is clogged with dirt. 2. Anti cavitation check valve seat is clogged with dirt. 3. Damage of O-ring for adjusting. 	<p>Disassembly, clean, reassembly.</p> <p>Disassembly, clean, reassembly.</p> <p>Replace.</p>
Abnormal noise	<ol style="list-style-type: none"> 1. Overload valve seat side clogged with dirt. 	<p>Disassembly, clean, reassembly.</p>
Leakage	<ol style="list-style-type: none"> 1. Loosen 2 mounting bolt. 2. Damage of O-ring. 3. Leakage through plug. 	<p>Retighten as specified torque.</p> <p>Replace.</p> <p>Apply seal tape to thread and retighten as specified torque.</p>

4. STEERING CYLINDER

1) STRUCTURE

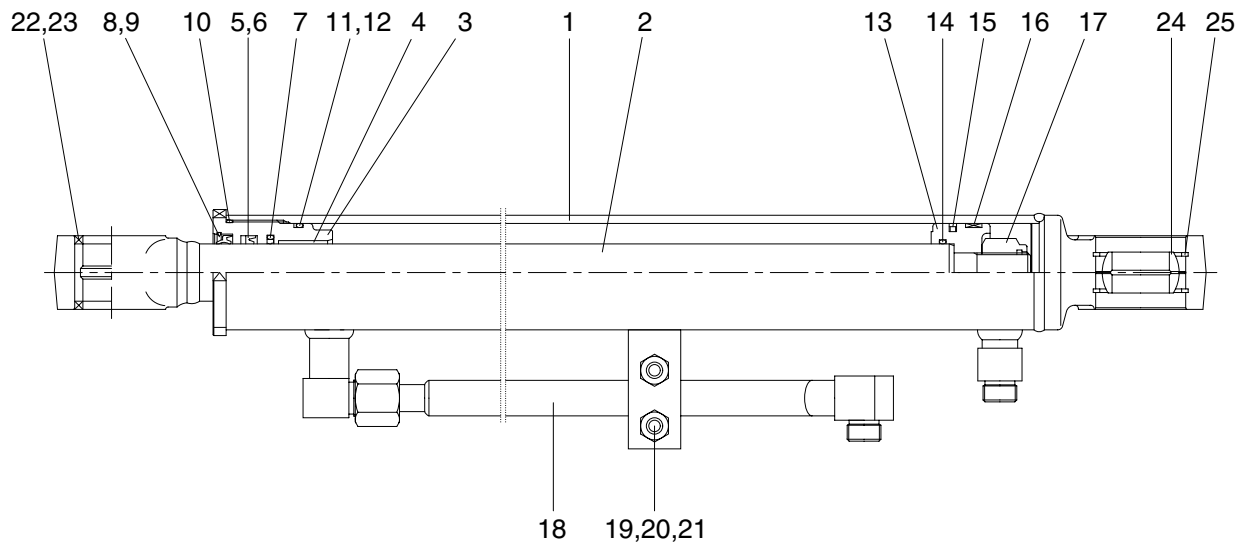

7307SE07

1	Tube assy	10	O-ring	18	Pipe assy
2	Rod assy	11	O-ring	19	U-bolt
3	Gland	12	Back up ring	20	Hexagon nut
4	Du bushing	13	Piston	21	Washer spring
5	Rod seal	14	O-ring	22	Bushing
6	Back up ring	15	Piston seal	23	Dust seal
7	Step seal	16	Wear ring	24	Spherical bearing
8	Dust wiper	17	Nylon nut	25	Retaining ring
9	Snap ring				

2) TOOLS AND TIGHTENING TORQUE

(1) Tools

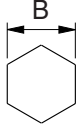
Tool name	Remark	
Spanner	17	
	32	
	36	
Steel bar	For gland	
(-) Driver	Small and large sizes	
Torque wrench	Capable of tightening with the specified torques	

(2) Tightening torque

Part name	Item	Size	Torque	
			kgf · m	lbf · ft
Gland	3	M64 × 1.5	65 ± 7	470 ± 51
Nylon nut	17	M24 × 2.0	40 ± 4	289 ± 29
Nut(Pipe assy)	18	M22 × 1.5	30 ± 3	217 ± 21.7
Nut	20	M10 × 1.5	3.2 ± 0.3	23.1 ± 2.2

3) DISASSEMBLY

(1) Remove cylinder head and piston rod

- ① Hold the clevis section of the tube in a vise.
- ※ Use mouth pieces so as not to damage the machined surface of the cylinder tube. Do not make use of the outside piping as a locking means.

- ② Pull out piston rod(2) about 200mm (7.1in). Because the piston rod is rather heavy, finish extending it with air pressure after the oil draining operation.

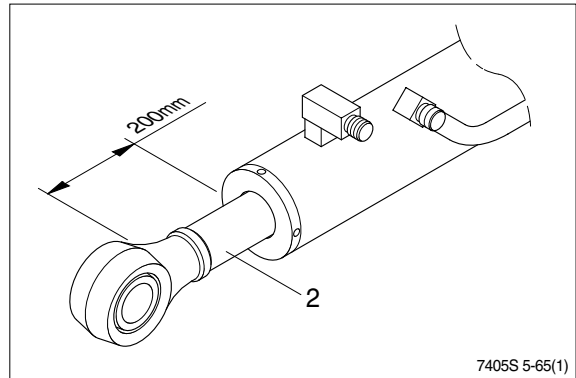

- ③ Loosen and remove the gland(3).
- ※ Cover the extracted piston rod(2) with rag to prevent it from being accidentally damaged during operation.

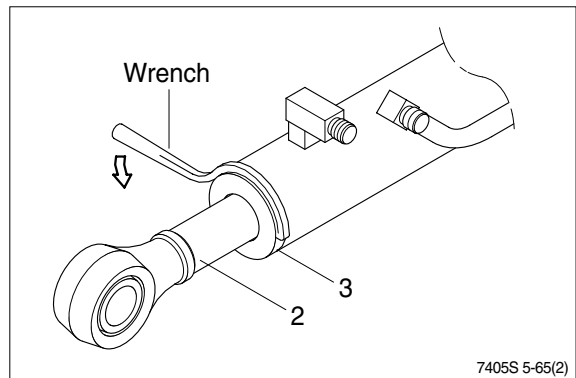

- ④ Draw out gland(3) and piston rod (2) assembly together from cylinder(1).
- ※ Since the piston rod assembly is heavy in this case, lift the tip of the piston rod(2) with a crane or some means and draw it out. However, when piston rod(2) has been drawn out to approximately two thirds of its length, lift it in its center to draw it completely.

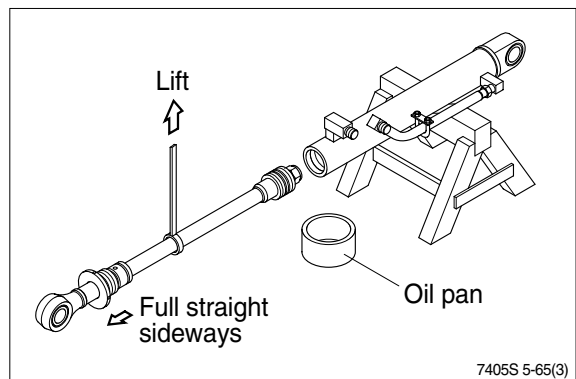

- ※ Note that the plated surface of piston rod(2) is to be lifted. For this reason, do not use a wire sling and others that may damage it, but use a strong cloth belt or a rope.

- ⑤ Place the removed piston rod assembly on a wooden V-block that is set level.
- ※ Cover a V-block with soft rag.

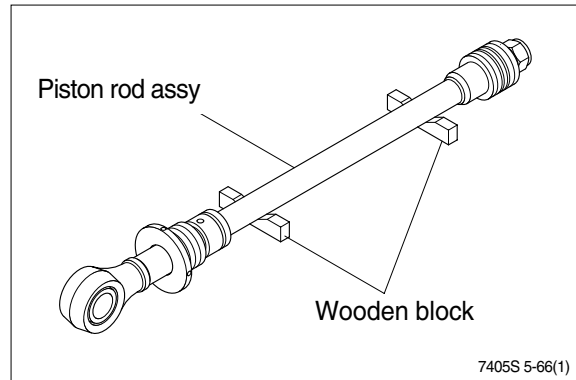

(2) Remove piston and gland assembly

- ① Remove the nylon nut(17).
- ② Remove piston assembly(13), and O-ring(14).

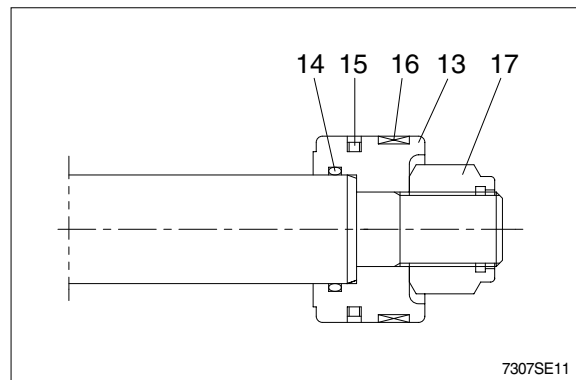

- ④ Remove the gland(3) assembly from piston rod(2).
- ※ If it is too heavy to move, move it by striking the flanged part of gland(3) with a plastic hammer.
 - ※ Pull it straight with cylinder head assembly lifted with a crane.
- Exercise care so as not to damage the lip of rod bushing(4) and packing (5,6,7,8,9) by the threads of piston rod(2).

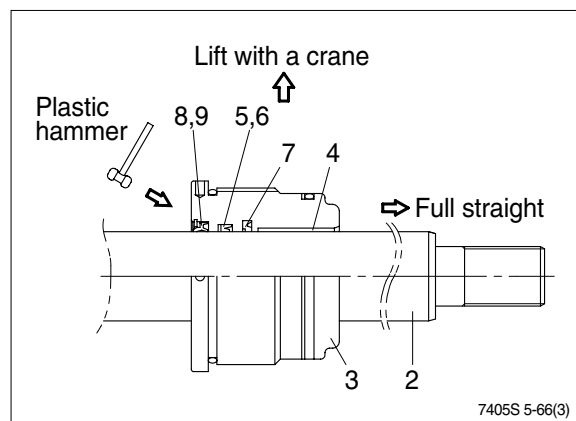

(3) Disassemble the piston assembly

- ① Remove wear ring(16) and piston seal (15).
- ※ Exercise care in this operation not to damage the grooves.

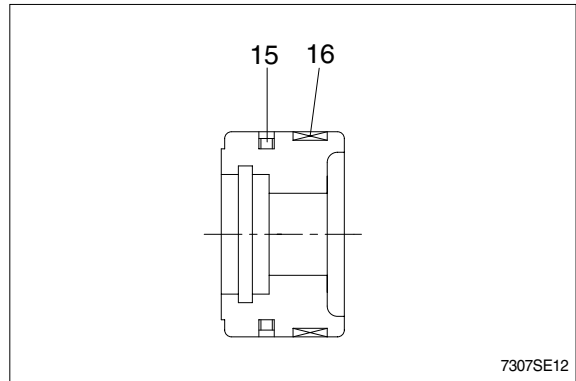

(4) Disassemble gland assembly

- ① Remove back up ring(12), and O-ring (11).
 - ② Remove O-ring(10).
 - ③ Remove snap ring(9) and dust wiper(8).
 - ④ Remove back up ring(6), rod seal(5).
 - ⑤ Remove step seal(7).
- ※ Exercise care in this operation not to damage the grooves.
- ※ Do not remove seal and ring, if does not damaged.

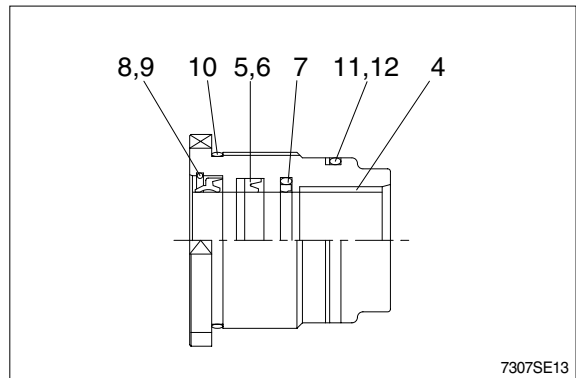

4) ASSEMBLY

(1) Assemble gland assembly

※ Check for scratches or rough surfaces if found smooth with an oil stone.

- ① Coat the inner face of gland(3) with hydraulic oil.

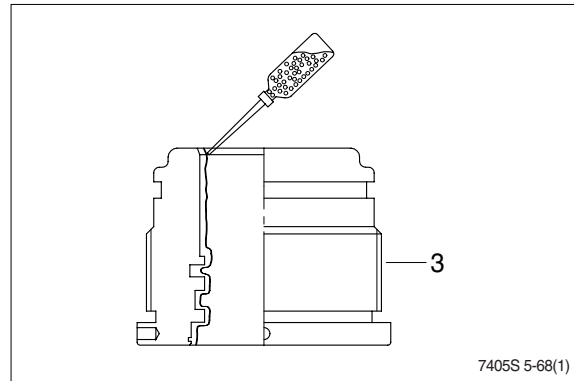

- ② Coat dust wiper(8) with grease and fit dust wiper(8) to the bottom of the hole of dust wiper.

At this time, press a pad metal to the metal ring of dust seal.

- ③ Fit snap ring(9) to the stop face.

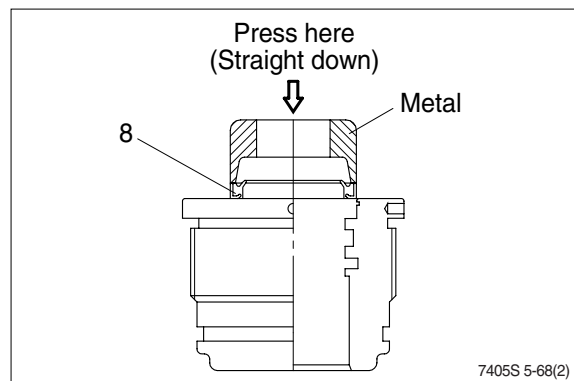

- ④ Fit back up ring(6) and rod seal(5) to corresponding grooves, in that order.

- ⑤ Fit step seal(7).

※ Coat each packing with hydraulic oil before fitting it.

※ Insert the back up ring until outside of it is inserted into groove.

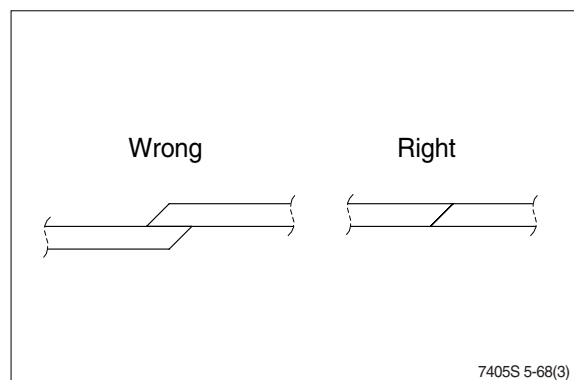

※ Rod seal(5) has its own fitting direction.

Therefore, confirm it before fitting them.

※ Fitting rod seal(5) and step seal(7) up side down may damage its lip. Therefore check the correct direction that is shown in fig.

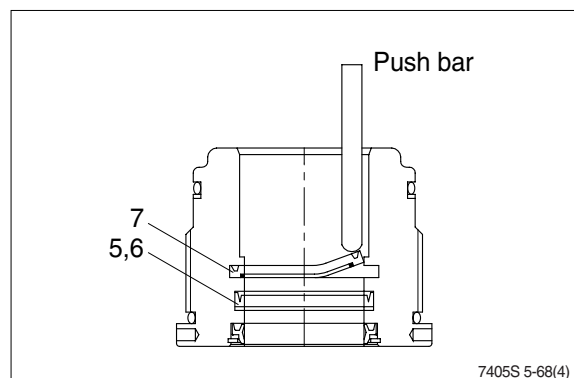

- ⑥ Fit back up ring(12) to gland (3).
- ※ Put the back up ring in the warm water of 30~50°C .
- ⑦ Fit O-ring(11) to gland(3).
- ⑧ Fit O-ring(10) to gland(3).

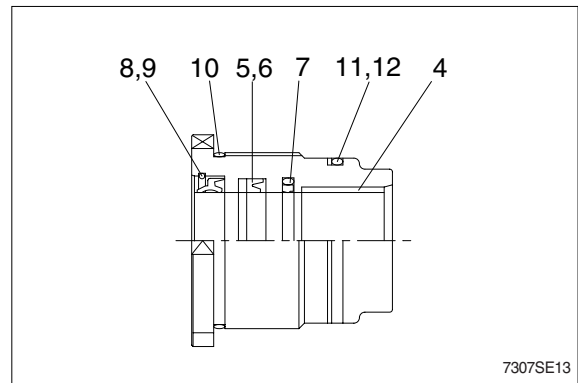

(2) Assemble piston assembly

- ※ Check for scratches or rough surfaces.
If found smooth with an oil stone.
- ① Coat the outer face of piston(13) with hydraulic oil.

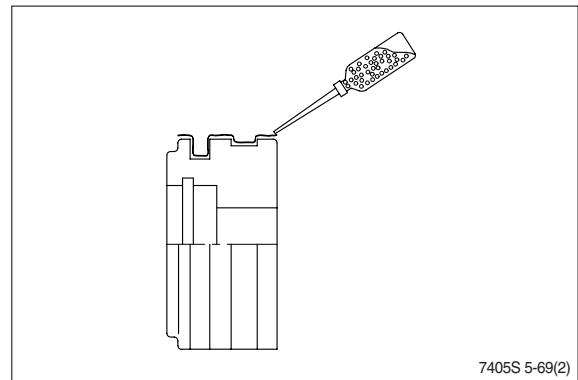

- ② Fit piston seal(15) to piston
- ※ Put the piston seal in the warm water of 60~100°C for more than 5 minutes.
- ※ After assembling the piston seal, press its outer diameter to fit in.

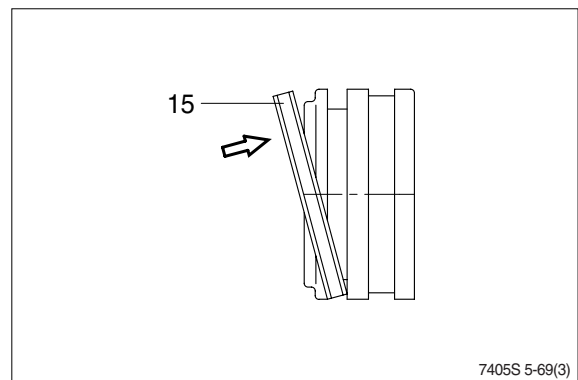

- ③ Fit wear ring(16) to piston(13).
- ④ Fit O-ring(14) to piston(13).

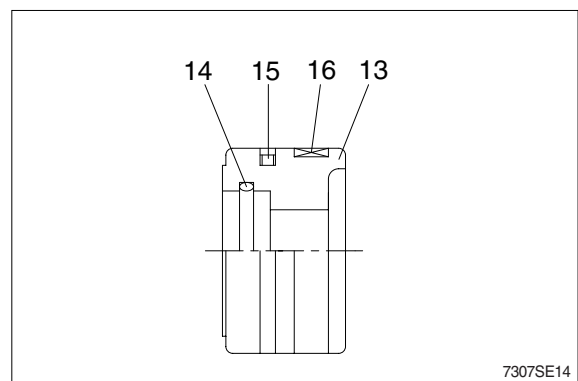

(3) Install piston and gland assembly

- ① Fix the piston rod assembly to the work bench.
- ② Apply hydraulic oil to the outer surface of piston rod(2), the inner surface of piston and gland.
- ③ Insert gland assembly to piston rod(2).

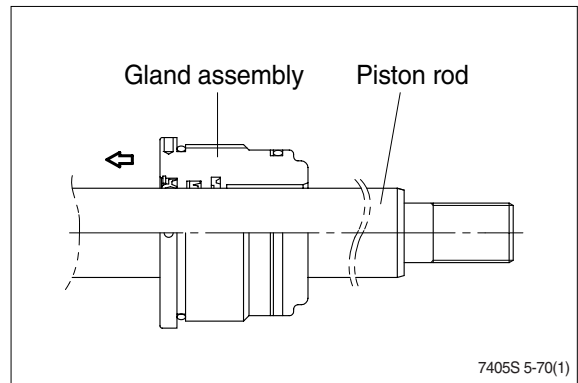

- ④ Fit piston assembly to piston rod.
 - Tightening torque : $65 \pm 7 \text{kgf} \cdot \text{m}$
($470 \pm 51 \text{lb} \cdot \text{ft}$)

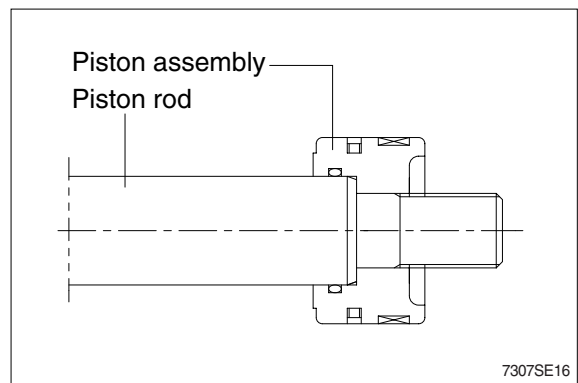

- ⑤ Tighten nylon nut(17) to piston rod(2).
 - Tightening torque : $40 \pm 4 \text{kgf} \cdot \text{m}$
($289 \pm 29 \text{lb} \cdot \text{ft}$)

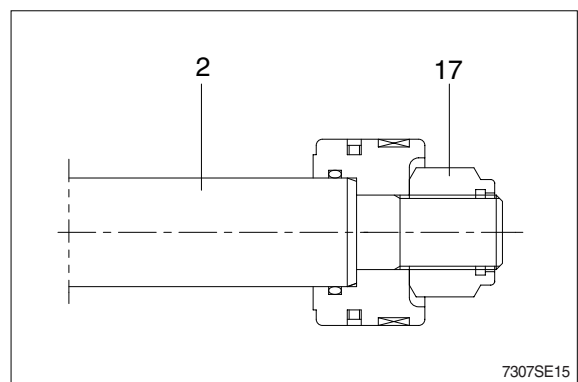

(4) Overall assemble

- ① Place a V-block on a rigid work bench.
Mount the cylinder tube assembly(1) on it and fix the assembly by passing a bar through the clevis pin hole to lock the assembly.
- ② Insert the piston rod assembly in to the cylinder tube assembly, while lifting and moving the piston rod assembly with a crane.
 - ※ Be careful not to damage piston seal by thread of cylinder tube.
- ③ Match the bolts holes in the cylinder head flange to the tapped holes in the cylinder tube assembly and tighten socket bolts to a specified torque.
 - ※ Refer to the table of tightening torque.

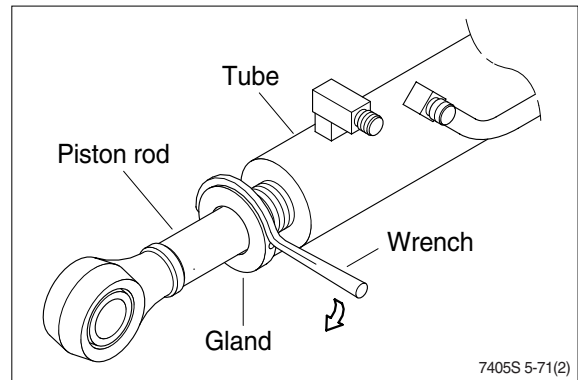
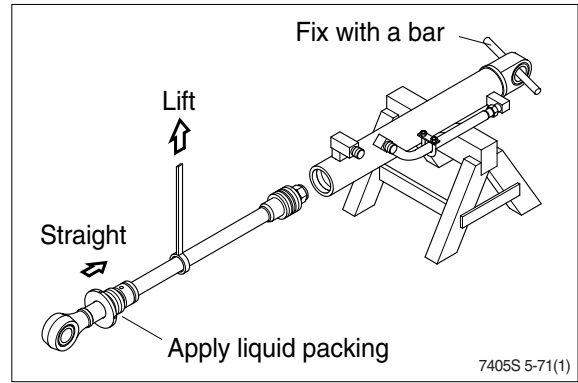

5. CENTER PIVOT PIN

1) CONSTRUCTION

Figure shows the construction of the center pivot pin assembly. This assembly serves to connect the front frame with the rear frame; two sets of assemblies are provided, one each for the upper and lower parts.

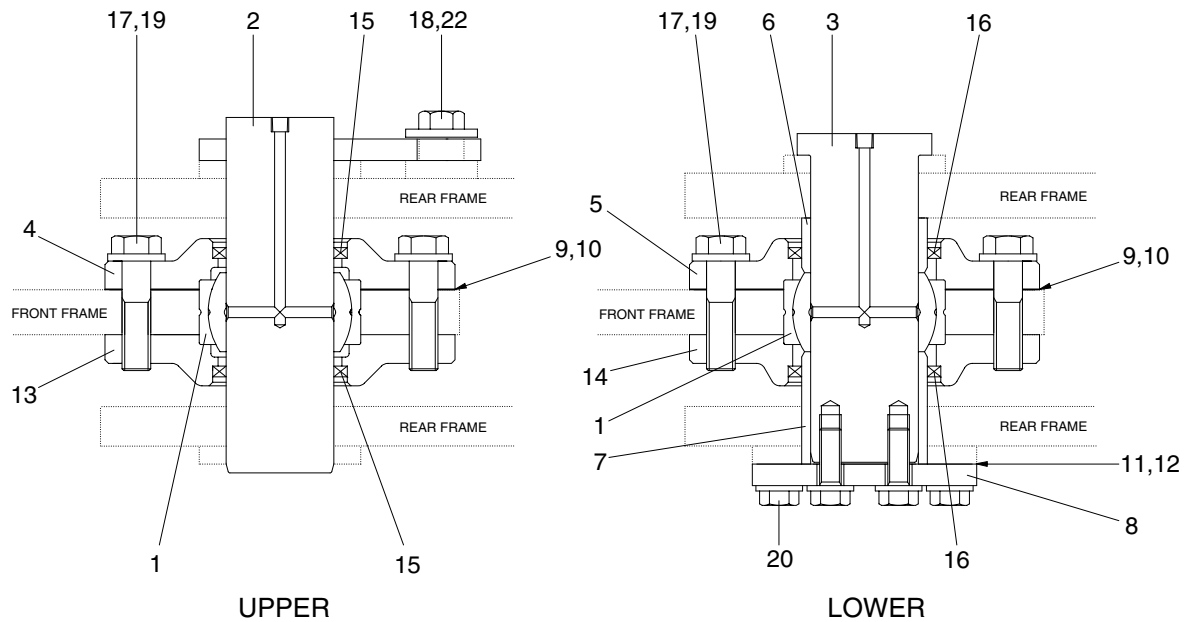

7307SE17

1	Bearing	8	Plate	15	Dust seal
2	Pin	9	Shim(0.1T)	16	Dust seal
3	Pin	10	Shim(0.5T)	17	Hexagon bolt
4	Cover	11	Shim(0.1T)	18	Hardened washer
5	Cover	12	Shim(0.5T)	19	Hardened washer
6	Collar	13	Cover	20	Hexagon bolt
7	Collar	14	Cover	22	Hexagon bolt

2) DISASSEMBLY

After supporting the front frame and the rear frame as horizontally as possible using wood blocks and jacks, disassemble as follows: In order to facilitate the disassembly/assembly of the center pivot pins, remove the drive shaft, hydraulic line and steering cylinder first.

- (1) Maintain the horizontal level of front frame and rear frame, and then remove hexagon bolt(22).
- (2) Take out upper pin(2) to the upside using a metal punch.

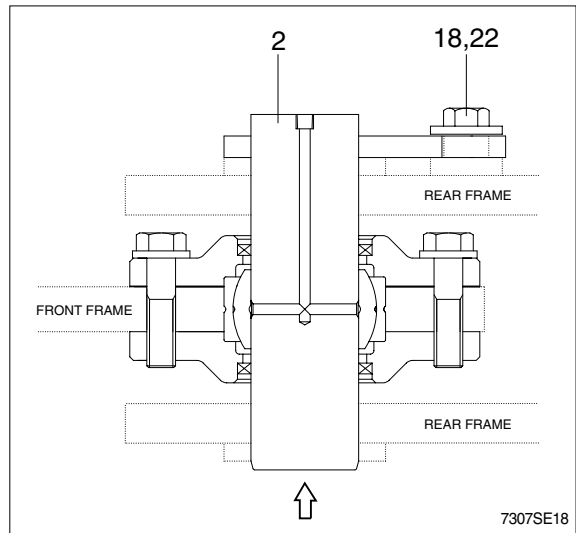

- (3) Maintain the front frame horizontal level, remove hexagon bolts(20) and then remove the plate(8) and shims(11,12).
- (4) Take out lower pin(3) to the upside using a metal punch carefully.
- (5) Jack up or lifting the front frame slightly, the collar(7) protrudes over the rear frame. Remove the collar(7).
- (6) Lift the frame by passing the slinging wire rope at four positions of front frame, in order to separate it from the rear frame.
- (7) Support the front frame safely.

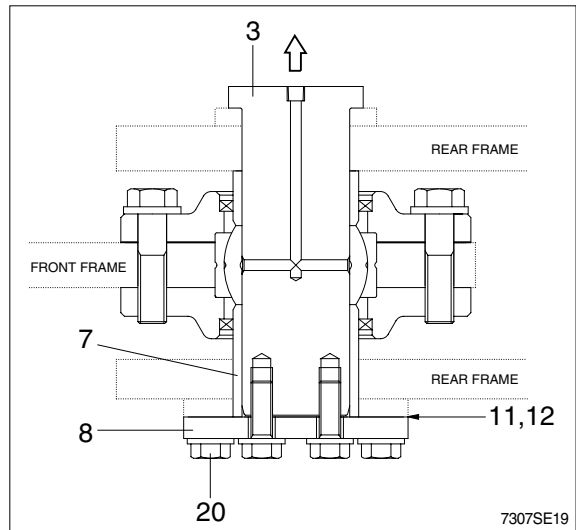

(8) Remove bolt(17) and then take out cover(4,13) and shims(9,10).

(9) Take out dust seal(15) from the cover(4).

(10) Remove the bearing(1), and dust seal(15).

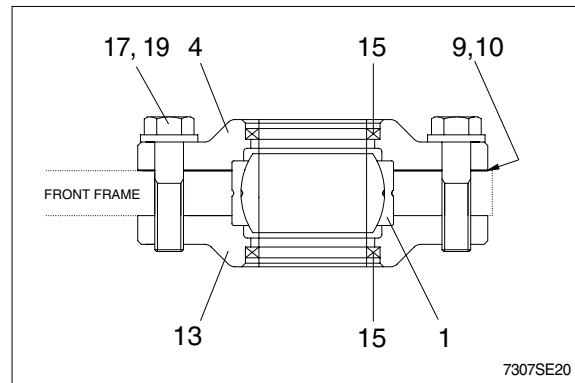

(11) Remove bolt(17) and then take out cover(5,14) and shims(9,10).

(12) Take out the dust seal(16) from the cover(5).

(13) Remove the bearing(1), collar(6) and dust seal(16).

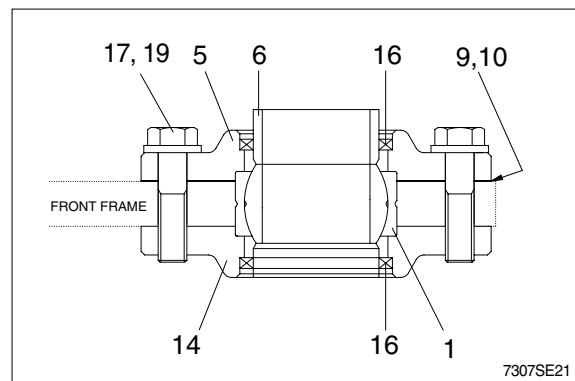

3) INSPECTION

(1) Check the bearing sliding surface for excessive wear, scorching or scratches; replace if necessary.

(2) Replace all dust seals(15, 16) with new ones.

(3) Grind any pins(2, 3) dented with an oilstone or replace any pins abrasive excessively.

(4) Check inside cover(4, 5, 13, 14) and collar(6, 7) for dents or scratches; if any damage is found, correct with a grinder or replace.

(5) The serviceable limit of pins and bushings is shown in the table below.

Unit : mm

Item No.	Name	Std dimension	Serviceable limit			Remedy
			Outer dia	Inner dia	Clearance	
2, 3	Pin	60	59	-	1	Replace
1	Spherical bearing		-	60.5		
6, 7	Collar		-	60.5		
15, 16	Dust seal	When removed			Replace	

4) ASSEMBLY

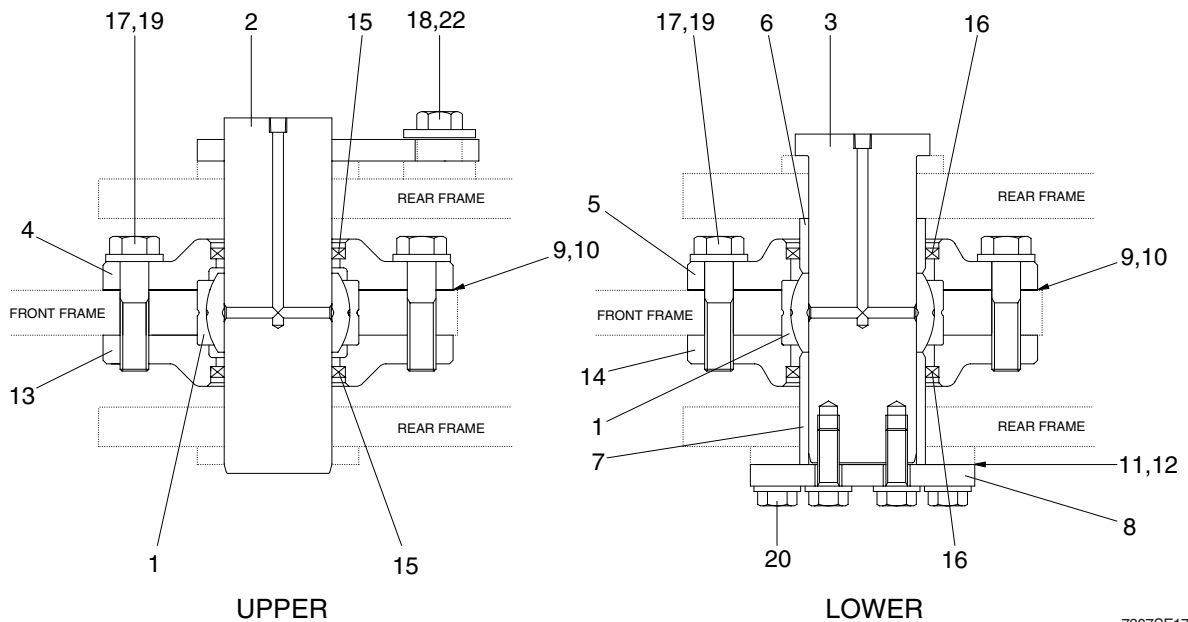

7307SE17

Assemble the center pivot group by reversing the order of disassembly while paying close attention to the following.

- (1) Put the dust seal(15, 16) into cover(4, 5, 13, 14).
 - ※ Apply grease to the lip of the dust seal. Insert the dust seal so that the dust seal lip faces out and punch four places on the outer circumference of the seal to lock it.
- (2) Apply grease to the inside of spherical bearing(1) and install it to front frame.
- (3) Assemble cover(4, 5, 13, 14). At this time, adjust shims(9, 10) to press shoulder of the bearing(1) against cover(4, 5, 13, 14).(Shim thickness 0.1mm, 0.5mm)
- (4) After setting the bearing so that its upper surface is horizontal, tighten the bolt(17).
After tightening, confirm that spherical bearing(1) moves lightly; if does not move smoothly, add shims(9, 10).
 - Tightening torque : $29.7 \pm 4.5 \text{kgf} \cdot \text{m} (215 \pm 32.5 \text{lbf} \cdot \text{ft})$
 - ※ Apply locktite #242.
- (5) Apply grease to upper collar(6) and insert it to the upper of spherical bearing(1).
- (6) Insert collar (7) to the upper of the lower side rear frame.
- (7) Move the front frame and join it to the rear frame so that match the pin hole at the center.
- (8) Apply grease to pin(2, 3) and insert it into spherical bearing(1).
- (9) Set plate(8); tighten hexagon bolt.
 - ※ Tightening torque
 - Item 18 : $29.7 \pm 4.5 \text{kgf} \cdot \text{m} (215 \pm 32.5 \text{lbf} \cdot \text{ft})$
 - Item 20 : $12.8 \pm 3 \text{kgf} \cdot \text{m} (92.6 \pm 21.7 \text{lbf} \cdot \text{ft})$
 - ※ Apply locktite #242.
- (10) Connect the piping, pins, electrical wiring, links, etc. and remove the wooden block supporting the frame.
- (11) Check the pin function at low revolution; and apply grease if no irregularity is found.

5) TROUBLESHOOTING

Trouble	Probable cause	Remedy
Shock is felt when steering	Capscrew for fixing steering valve is loose	Retighten
	Faulty center pivot pin mounting bolts	Retighten
	Center pivot pins have worn out	Readjust or replace
	Faulty hydraulic system	See hydraulic system
Shock is felt when moving backward or forward	Fault fixing of connecting capscrews	Retighten
	Center pins have worn out	Readjust or replace
	Bearings of support unit have worn out	Retighten
	Drive shaft damaged	See drive system
	Faulty transmission	See transmission system