

## GROUP 3 TESTS AND ADJUSTMENTS

### 1. CLUTCH CUT-OFF PRESSURE SWITCH TEST

The setting pressure of the clutch cut-off pressure switch should be suited with the specification. The rated pressure is 25kgf/cm<sup>2</sup>. For the detailed method for pressure adjusting, refer to page 4-22.

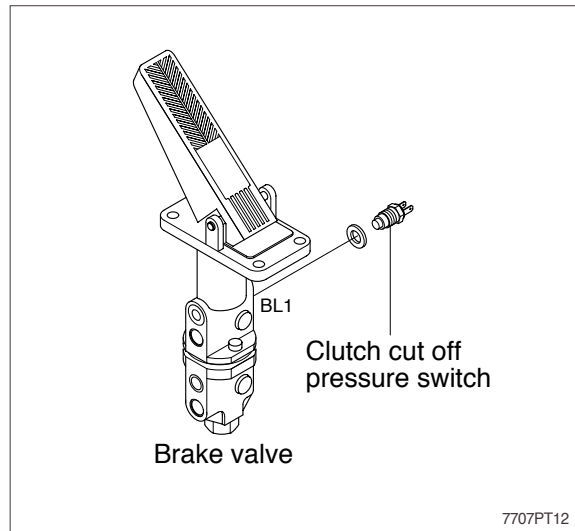

## 2. TRANSMISSION MEASURING POINTS AND CONNECTIONS

The measurements have to be carried out at hot transmission (About 80~95°C).

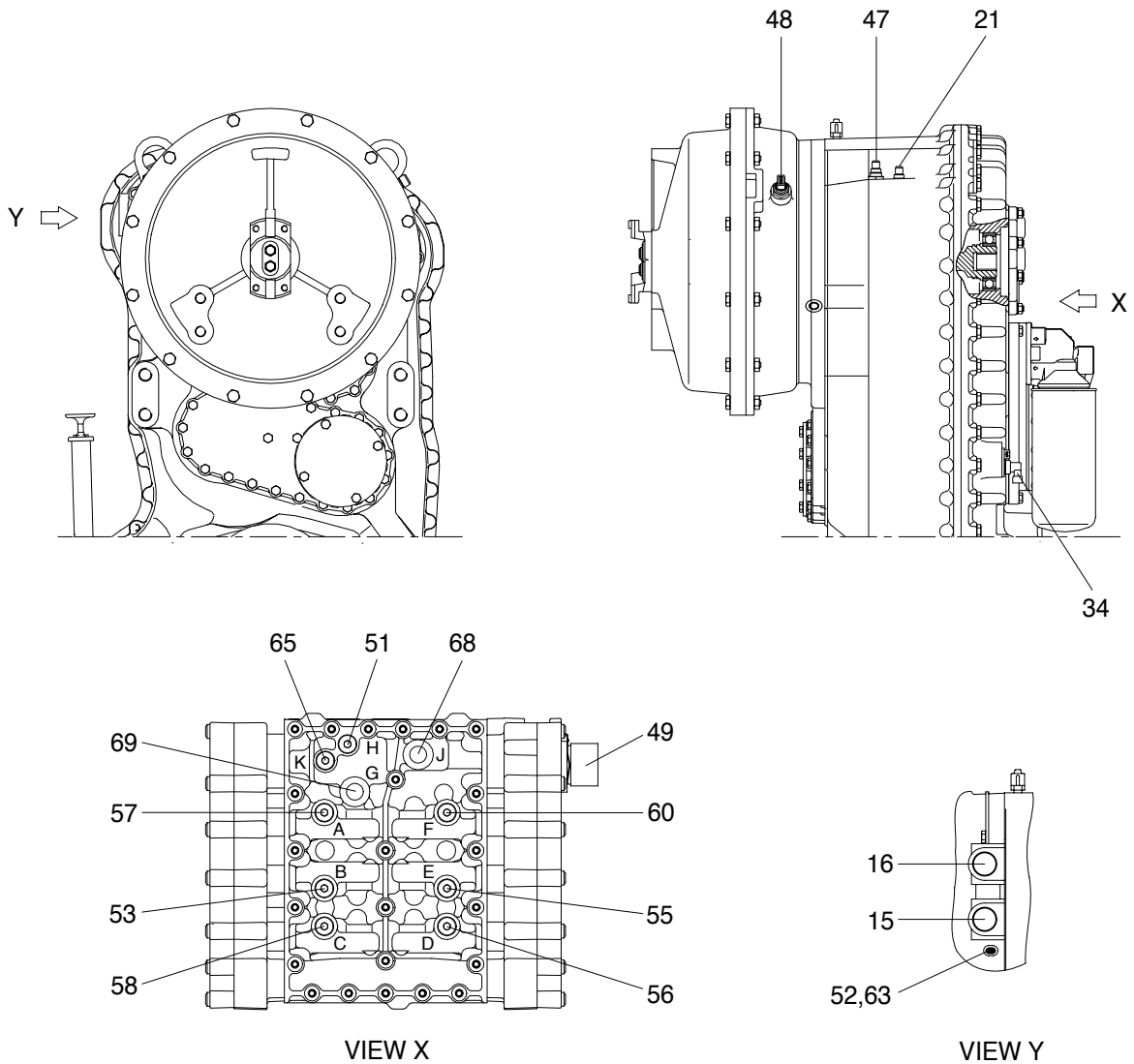

73033TM04

### 1) OIL PRESSURE AND TEMPERATURE

Port	Description		Size
51	Converter inlet-opening pressure(9bar)	H	M10 × 1
52	Converter outlet-opening pressure(3.5bar)		M14 × 1.5
53	Forward clutch(16+2bar)	B	M10 × 1
55	Reverse clutch(16+2bar)	E	M10 × 1
56	1st clutch(16+2bar)	D	M10 × 1
57	2nd clutch(16+2bar)	A	M10 × 1
58	3rd clutch(16+2bar)	C	M10 × 1
60	4th clutch(16+2bar)	F	M10 × 1
63	Converter outlet temperature 100, C , short-time 120, C		M14 × 1.5
65	System pressure(16+2bar)	K	M10 × 1

## 2) DELIVERY RATES

Port	Description	Size
15	Connection to oil cooler	1 5/16"-12UNF-2B
16	Connection from the oil cooler	1 5/16"-12UNF-2B

## 3) INDUCTIVE TRANSMITTER AND SPEED SENSOR

Port	Description	Size
21	Inductive transmitter n turbine	M18 x 1.5
34	Speed sensor n output and speedometer	-
47	Inductive transmitter n central gear train	M18 x 1.5
48	Inductive transmitter n engine	M18 x 1.5

## 4) CONNECTIONS

Port	Description	Size
49	Plug connection on the hydraulic control unit	-
68	Pilot pressure(Optional) J	M16 x 1.5
69	System pressure(Optional) G	M16 x 1.5