

**GROUP 2 SPECIFICATION**

**1. MAJOR COMPONENT(HL730-7)**

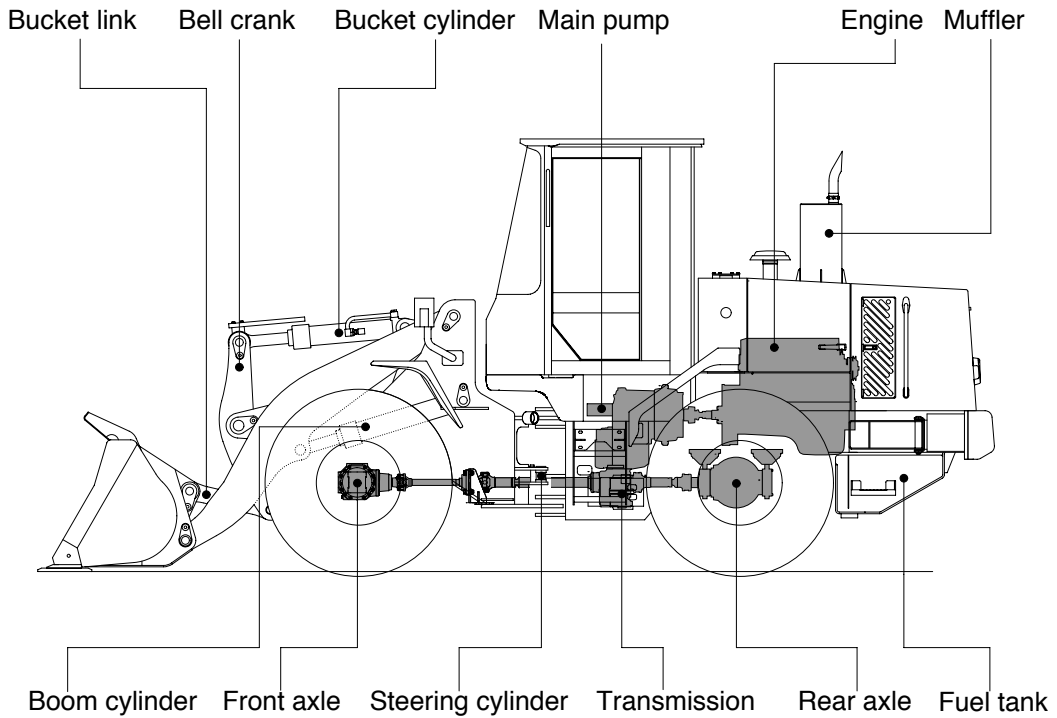
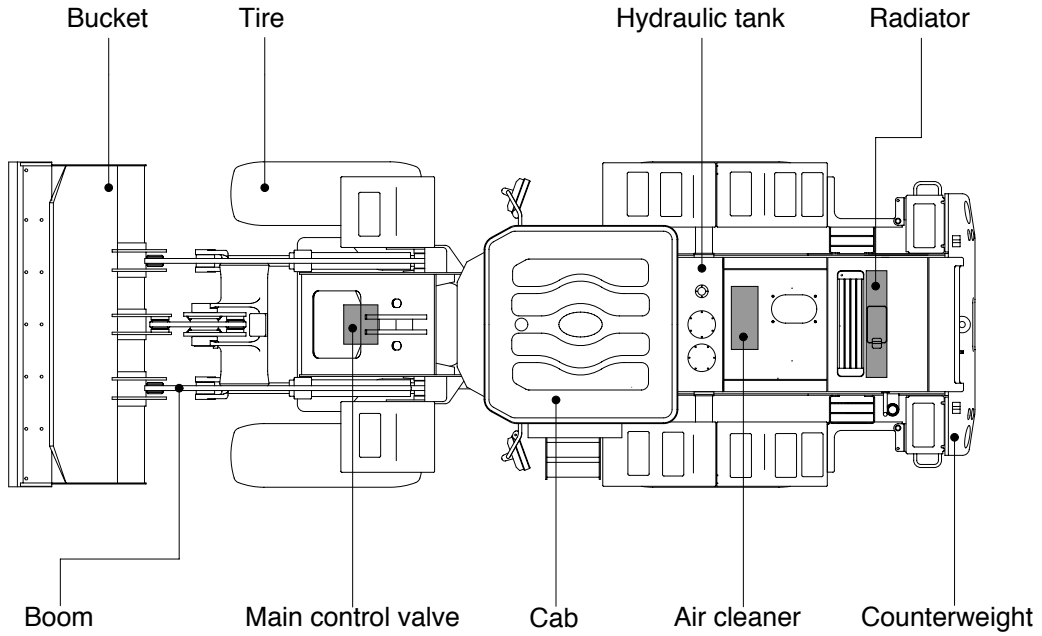

73072SP01

**MAJOR COMPONENT(HL730TM-7)**

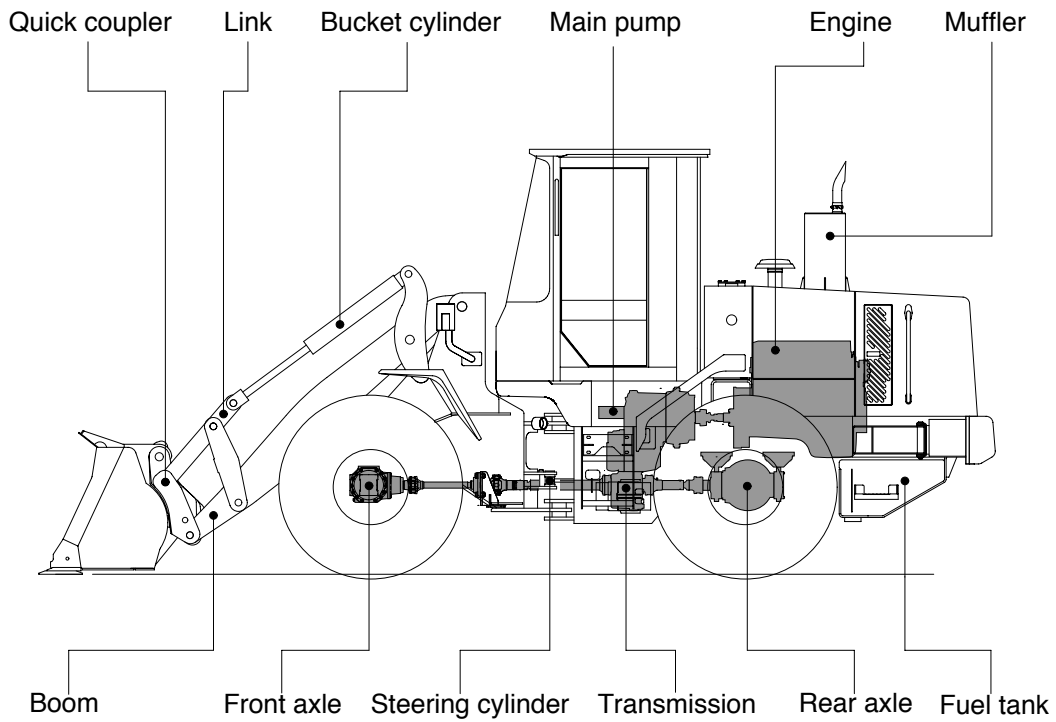
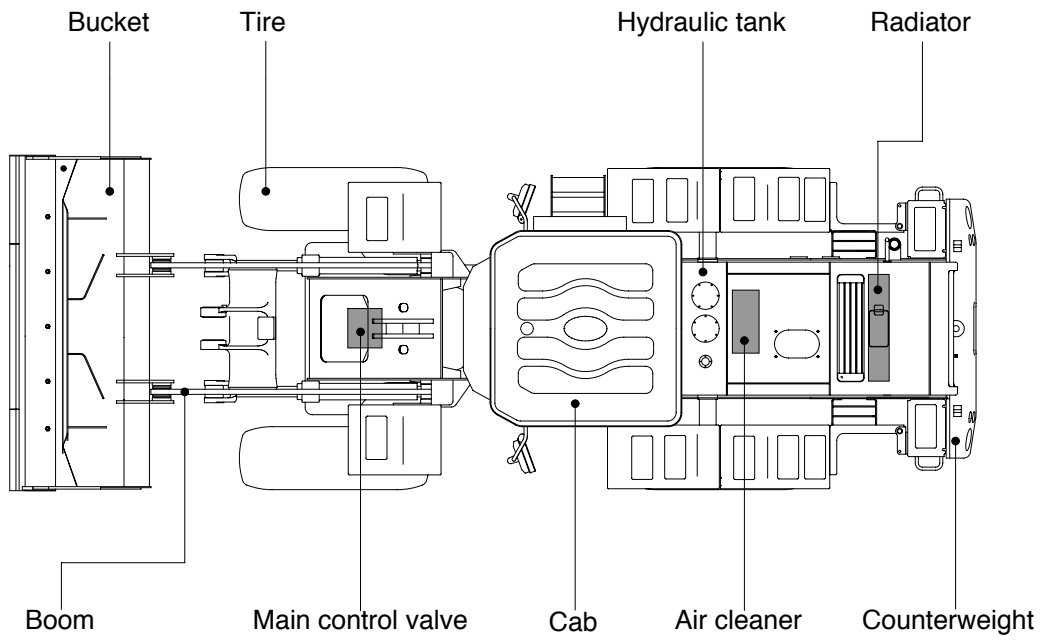

730TM72SP01

## 2. SPECIFICATIONS

### 1) WITHOUT TOOTH AND CUTTING EDGE TYPE BUCKET(HL730-7)

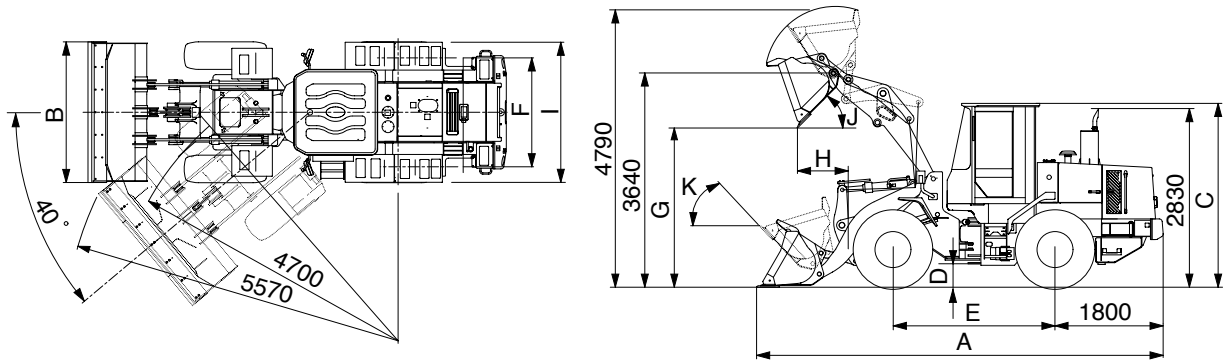

73072SP02

Description		Unit	Specification	
Operating weight		kg(lb)	9700(21380)	
Bucket capacity	Struck	m <sup>3</sup> (yd <sup>3</sup> )	1.4(1.9)	
	Heaped		1.7(2.2)	
Overall length	A	mm(ft-in)	6770(22' 3")	
Overall width	B		2450( 8' 0")	
Overall height	C		3120(10' 3")	
Ground clearance	D		370( 1' 3")	
Wheelbase	E		2750( 9' 0")	
Tread	F		1850( 6' 0")	
Dump clearance at 45°	G		2780( 9' 1")	
Dump reach(Full lift)	H		970( 3' 2")	
Width over tires	I		2295( 7' 6")	
Dump angle	J		Degree (°)	48
Roll back angle(Carry position)	K		Degree (°)	48
Cycle time	Lift(With load)		sec	5.2
	Dump(With load)			1.0
	Lower(Empty)	2.3		
Maximum travel speed		km/hr(mph)	37.0(23.1)	
Braking distance		m(ft-in)	12(39' 4")	
Minimum turning radius(Center of outside tire)			4.70(15' 5")	
Gradability		Degree (°)	30	
Travel speed	Forward	First gear	6.9(4.3)	
		Second gear	12.1(7.5)	
		Third gear	22.1(13.8)	
		Fourth gear	37.0(23.1)	
	Reverse	First gear	7.3(4.5)	
		Second gear	12.8(8.0)	
Third gear		23.3(14.5)		

**WITHOUT TOOTH AND CUTTING EDGE TYPE BUCKET(HL730TM-7)**

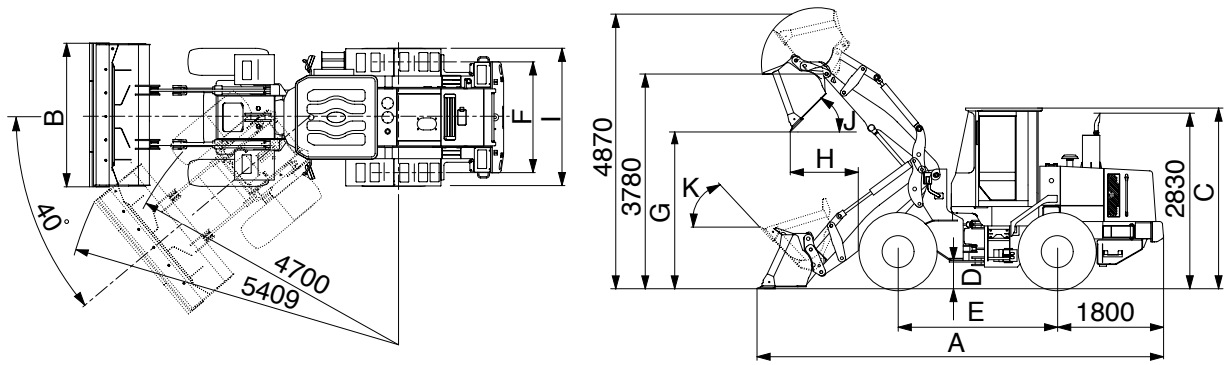

730TM72SP02

Description		Unit	Specification	
Operating weight		kg(lb)	10000(22050)	
Bucket capacity	Struck	m <sup>3</sup> (yd <sup>3</sup> )	1.4(1.9)	
	Heaped		1.6(2.1)	
Overall length	A	mm(ft-in)	6920(22' 8")	
Overall width	B		2400( 7' 10")	
Overall height	C		3120(10' 3")	
Ground clearance	D		370( 1' 3")	
Wheelbase	E		2750( 9' 0")	
Tread	F		1850( 6' 0")	
Dump clearance at 45.	G		2845( 9' 4")	
Dump reach(Full lift)	H		1115( 3' 8")	
Width over tires	I		2295( 7' 6")	
Dump angle	J		Degree (°)	50
Roll back angle(Carry position)	K			54
Cycle time	Lift(With load)		sec	5.4
	Dump(With load)			1.4
	Lower(Empty)	2.4		
Maximum travel speed		km/hr(mph)	37.0(23.1)	
Braking distance		m(ft-in)	12(39' 4")	
Minimum turning radius(Center of outside tire)			4.7(15' 5")	
Gradability		Degree (°)	30	
Travel speed	Forward	First gear	6.9(4.3)	
		Second gear	12.1(7.5)	
		Third gear	22.1(13.8)	
		Fourth gear	37.0(23.1)	
	Reverse	First gear	7.3(4.5)	
		Second gear	12.8(8.0)	
Third gear		23.3(14.5)		

## 2) WITH BOLT-ON CUTTING EDGE TYPE BUCKET(HL730-7)

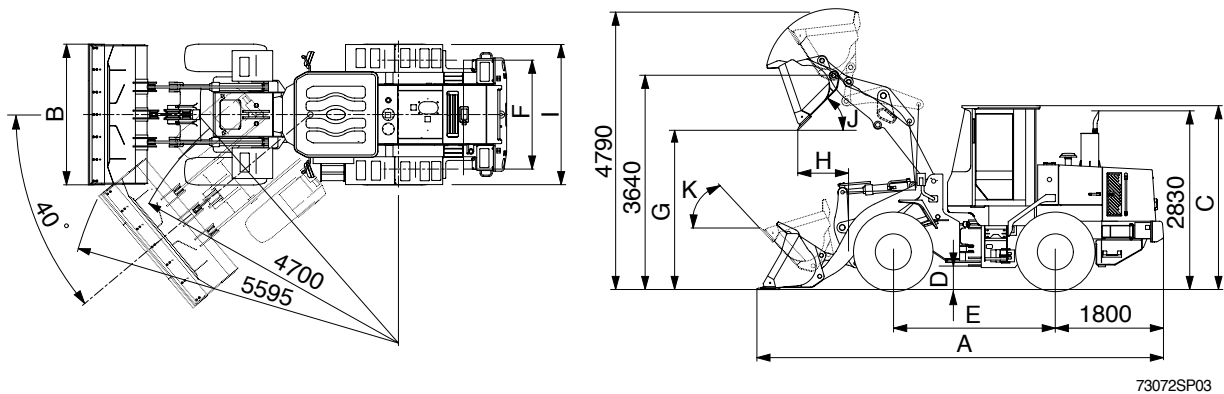

73072SP03

Description		Unit	Specification	
Operating weight		kg(lb)	9700(21380)	
Bucket capacity	Struck	m <sup>3</sup> (yd <sup>3</sup> )	1.5(2.0)	
	Heaped		1.8(2.4)	
Overall length	A	mm(ft-in)	6850(22' 6")	
Overall width	B		2450( 8' 0")	
Overall height	C		3120(10' 3")	
Ground clearance	D		370( 1' 3")	
Wheelbase	E		2750( 9' 0")	
Tread	F		1850( 6' 0")	
Dump clearance at 45.	G		2730( 8' 11")	
Dump reach(Full lift)	H		1005( 3' 4")	
Width over tires	I		2295( 7' 6")	
Dump angle	J		Degree (°)	48
Roll back angle(Carry position)	K			48
Cycle time	Lift(With load)	sec	5.2	
	Dump(With load)		1.0	
	Lower(Empty)		2.3	
Maximum travel speed		km/hr(mph)	37.0(23.1)	
Braking distance		m(ft-in)	12(39' 4")	
Minimum turning radius(Center of outside tire)			4.70(15' 5")	
Gradability		Degree (°)	30	
Travel speed	Forward	First gear	6.9(4.3)	
		Second gear	12.1(7.5)	
		Third gear	22.1(13.8)	
		Fourth gear	37.0(23.1)	
	Reverse	First gear	7.3(4.5)	
		Second gear	12.8(8.0)	
Third gear		23.3(14.5)		

**WITH BOLT-ON CUTTING EDGE TYPE BUCKET(HL730TM-7)**

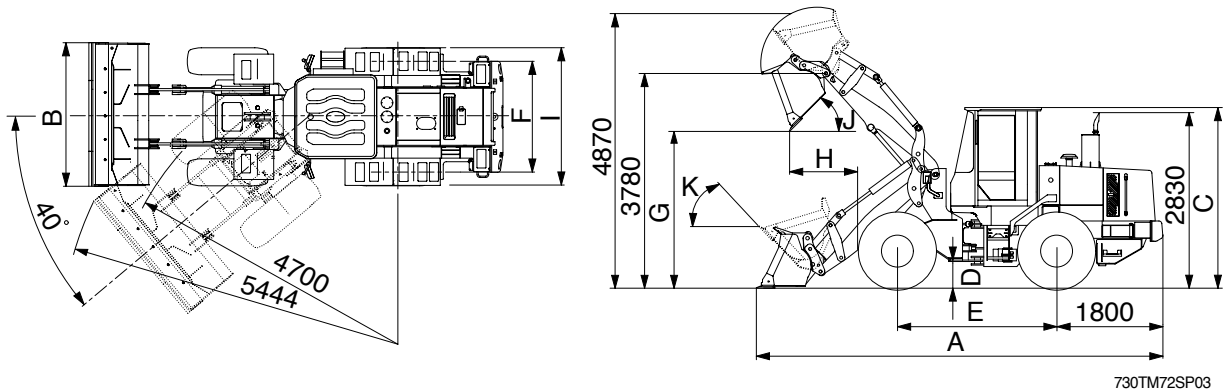

730TM72SP03

Description		Unit	Specification	
Operating weight		kg(lb)	10000(22050)	
Bucket capacity	Struck	m <sup>3</sup> (yd <sup>3</sup> )	1.5(2.0)	
	Heaped		1.7(2.2)	
Overall length	A	mm(ft-in)	7000(24' 9")	
Overall width	B		2400( 8' 4")	
Overall height	C		3120(10' 3")	
Ground clearance	D		370( 1' 3")	
Wheelbase	E		2750( 9' 0")	
Tread	F		1850( 6' 0")	
Dump clearance at 45.	G		2785( 9' 2")	
Dump reach(Full lift)	H		1140( 3' 9")	
Width over tires	I		2295( 7' 6")	
Dump angle	J		Degree (.)	50
Roll back angle(Carry position)	K			54
Cycle time	Lift(With load)		sec	5.4
	Dump(With load)	1.4		
	Lower(Empty)	2.4		
Maximum travel speed		km/hr(mph)	37.0(23.1)	
Braking distance		m(ft-in)	12(39' 4")	
Minimum turning radius(Center of outside tire)			4.7(15' 5")	
Gradability		Degree (.)	30	
Travel speed	Forward	km/hr(mph)	First gear	
			Second gear	
			Third gear	
			Fourth gear	
	Reverse		First gear	
			Second gear	
Third gear				

### 3) WITH TOOTH TYPE BUCKET(HL730-7 ONLY)

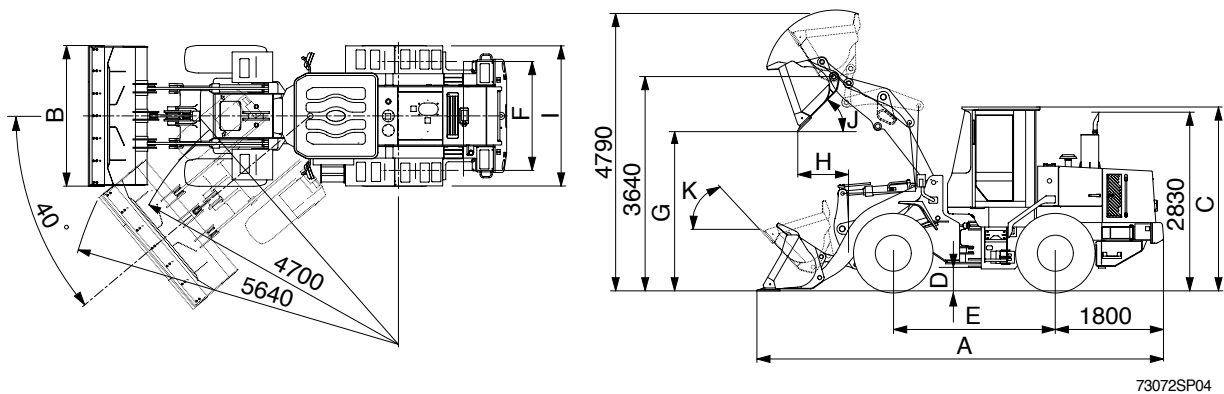

Description		Unit	Specification	
Operating weight		kg(lb)	9700(21380)	
Bucket capacity	Struck	m <sup>3</sup> (yd <sup>3</sup> )	1.4(1.9)	
	Heaped		1.7(2.2)	
Overall length	A	mm(ft-in)	6950(22' 10")	
Overall width	B		2480( 8' 2")	
Overall height	C		3120(10' 3")	
Ground clearance	D		370( 1' 3")	
Wheelbase	E		2750( 9' 0")	
Tread	F		1850( 6' 0")	
Dump clearance at 45°	G		2650( 8' 8")	
Dump reach(Full lift)	H		1075( 3' 6")	
Width over tires	I		2295( 7' 6")	
Dump angle	J		Degree (°)	48
Roll back angle(Carry position)	K			48
Cycle time	Lift(With load)	sec	5.2	
	Dump(With load)		1.0	
	Lower(Empty)		2.3	
Maximum travel speed		km/hr(mph)	37.0(23.1)	
Braking distance		m(ft-in)	12(39' 4")	
Minimum turning radius(Center of outside tire)			4.70(15' 5")	
Gradability		Degree (°)	30	
Travel speed	Forward	km/hr(mph)	First gear	
			Second gear	
			Third gear	
			Fourth gear	
	Reverse		First gear	
			Second gear	
Third gear				

### 3. WEIGHT

Item	HL730-7	HL730TM-7	HL730-7	HL730TM-7
	kg		lb	
Front frame assembly	750	760	1650	1680
Rear frame assembly	1000		2200	
Front fender(LH & RH)	20		44	
Rear fender(LH & RH)	33		73	
Counterweight	300	410	660	900
Cab assembly	820		1810	
Engine assembly	340		750	
Transmission assembly	380		840	
Drive shaft(Upper, engine to transmission)	7		15	
Drive shaft(Front)	17		37	
Drive shaft(Center)	17		37	
Drive shaft(Rear)	9		20	
Front axle(Include differential)	490		1080	
Rear axle(Include differential)	480		1060	
Tire(4EA)	330		730	
Hydraulic tank	170		380	
Fuel tank	240		530	
Main pump assembly	26		57	
Main control valve	22		49	
Boom assembly	540	510	1190	1120
Bell crank assembly	140	-	310	-
Bucket link	27	41	60	90
Quick coupler	-	210	-	460
Bucket, with bolt on cutting edge	710	610	1570	1340
Bucket, with tooth	780	-	1720	-
Without tooth and cutting edge	640	600	1410	1320
Boom cylinder assembly(2EA)	70		150	
Bucket cylinder assembly	78	62	170	140
Steering cylinder assembly(2EA)	15		30	
Quick coupler cylinder assembly	-	5.5	-	12
Seat	40		88	
Battery	28		62	

#### 4. SPECIFICATION FOR MAJOR COMPONENTS

##### 1) ENGINE

Item	Specification
Model	Cummins B3.9-C
Type	4-cycle turbocharged and after cooled diesel engine
Cooling method	Water cooling
Number of cylinders and arrangement	4 cylinders, in-line
Firing order	1-3-2-4
Combustion chamber type	Direct injection type
Cylinder bore x stroke	102 x 120mm(4.02" x 4.72")
Piston displacement	3920cc(239cu in)
Compression ratio	18.0 : 1
Rated gross horse power	125hp at 2200rpm
Maximum gross torque at 1300rpm	52kgf · m(376lb · ft)
Engine oil quantity	11 (2.9 U.S. gal)
Dry weight	338kg(745lb)
High idling speed	2420 ± 50rpm
Low idling speed	1000 ± 50rpm
Rated fuel consumption	231g/kw · hr
Starting motor	Nippondenso 228000-7902 (24V-3.7kw)
Alternator	Delco Remy 22SI(24V-70Amp)
Battery	2 x 12V x 100Ah

## 2) MAIN PUMP

Item	Specification
Type	Fixed displacement tandem helical gear pump
Capacity	36+28.5cc/rev
Maximum operating pressure	210kgf/cm <sup>2</sup> (2990psi)
Rated operating speed	2200rpm
Rated output flow	140 /min(40U.S.gpm)

## 3) FAN AND BRAKE PUMP

Item	Specification	
	Fan	Brake
Type	Fixed displacement tandem helical gear pump	
Capacity	16.8cc/rev	8.2cc/rev
Maximum operating pressure	100kgf/cm <sup>2</sup> (1422psi)	150kgf/cm <sup>2</sup> (2130psi)
Rated operating speed	2200rpm	
Rated output flow	35 /min(9.2U.S.gpm)	17 /min(4.5U.S.gpm)

## 4) MAIN CONTROL VALVE

Item	Specification
Type	2 spool(sectional block)
Operating method	Hydraulic pilot assist
Main relief valve set pressure	210kgf/cm <sup>2</sup> (2990psi)
Overload relief valve set pressure	240kgf/cm <sup>2</sup> (3414psi)

## 5) REMOTE CONTROL VALVE

Item	Specification	
Type	Joystick(or with aux lever)	
Control pressure	Minimum	3.7kgf/cm <sup>2</sup> (52.6psi)
	Maximum	30kgf/cm <sup>2</sup> (427psi)

## 6) CYLINDER

Item	Specification
Boom cylinder	Bore dia × Rod dia × Stroke Ø 105 × Ø 65 × 772mm
Bucket cylinder	Bore dia × Rod dia × Stroke Ø 120 × Ø 70 × 510mm
Steering cylinder	Bore dia × Rod dia × Stroke Ø 60 × Ø 35 × 412mm
Quick coupler cylinder	Bore dia × Rod dia × Stroke Ø 50 × Ø 25 × 79mm

## 7) DYNAMIC POWER TRANSMISSION DEVICES

Item		Specification
Torque converter	Model	ZF 4WG130
	Type	Single-stage, single-phase
Transmission	Type	Full-automatic power shift
	Gear shift	Forward fourth gear, reverse third gear
	Adjustment	Electrical single lever type, kick-down system
Axle	Drive devices	4-wheel drive
	Front	Front fixed location
	Rear	Oscillation $\pm 13^\circ$ of center pin-loaded
Wheels	Tires	17.5-25, 12PR(L3)
Brakes	Travel	Four-wheel, wet-disc type, full hydraulic
	Parking	Spring applied, hydraulic released brake in front axle
Steering	Type	Full hydraulic, articulated
	Steering angle	40° to both right and left angle, respectively

## 5. TIGHTENING TORQUE OF MAJOR COMPONENT

No	Items	Size	kgf · m	lbf · ft	
1	Engine	Engine mounting bolt, nut(4EA)	M16 × 2.0	29.7 ± 4.5	215 ± 32.5
2		Engine mounting bolt(Bracket)	M12 × 1.75	10.7 ± 1.6	77.4 ± 11.6
3		Radiator mounting bolt	M16 × 2.0	29.7 ± 4.5	215 ± 32.5
4		Fuel tank mounting bolt	M16 × 2.0	29.7 ± 4.5	215 ± 32.5
5		Air cleaner mounting bolt(4EA)	M 8 × 1.25	2.5 ± 0.5	18.1 ± 3.6
6	Hydraulic system	Main pump housing mounting bolt	M14 × 2.0	19.6 ± 2.9	142 ± 20.9
7		Main control valve mounting bolt	M12 × 1.75	12.8 ± 3.0	92.6 ± 21.7
8		Steering unit mounting bolt	M10 × 1.5	6.9 ± 1.4	49.9 ± 10.1
9		Priority valve	M 8 × 1.25	2.5 ± 0.5	18.1 ± 3.6
10		Brake valve mounting bolt	M 8 × 1.25	2.5 ± 0.5	18.1 ± 3.6
11		Fan and brake pump mounting bolt	M10 × 1.5	6.9 ± 1.4	49.9 ± 10.1
12		Cut-off valve mounting bolt	M12 × 1.75	12.8 ± 3.0	92.6 ± 21.7
13		Remote control lever mounting bolt	M 6 × 1.0	1.1 ± 0.2	8.0 ± 1.4
14		Pilot supply unit mounting bolt	M 8 × 1.25	2.5 ± 0.5	18.1 ± 3.6
15		Safety valve	M 8 × 1.25	2.5 ± 0.5	18.1 ± 3.6
16	Hydraulic oil tank mounting bolt	M16 × 2.0	29.7 ± 4.5	215 ± 32.5	
17	Power train system	Transmission mounting bolt(Bracket, front)	M20 × 2.5	57.9 ± 8.7	419 ± 62.9
18		Transmission mounting bolt(Bracket, rear)	M16 × 2.0	18.4 ± 2.0	133 ± 14.5
19		Front axle mounting bolt, nut	M24 × 2.5	100 ± 15	723 ± 109
20		Rear axle support mounting bolt, nut	M24 × 2.0	100 ± 15	723 ± 109
21		Tire mounting nut(17.5-25, 12PR, L3)	M22 × 1.5	70 ± 2.0	506 ± 15
22		Drive shaft joint mounting bolt	3/8-24UNF	6.0 ± 0.8	43.4 ± 5.8
23	Others	Counterweight mounting bolt, nut	M24 × 2.0	107 ± 16	773 ± 116
24		Operator's seat mounting bolt	M 8 × 1.25	3.4 ± 0.8	24.6 ± 5
25		ROPS Cab mounting bolt(4EA)	M24 × 3.0	27.5 ± 2.5	199 ± 18.1

## 6. TORQUE CHART

Use following table for unspecified torque.

### 1) BOLT AND NUT

#### (1) Coarse thread

Bolt size	8T		10T	
	kgf · m	lbf · ft	kgf · m	lbf · ft
M 6 × 1.0	0.85 ~ 1.25	6.15 ~ 9.04	1.14 ~ 1.74	8.2 ~ 12.6
M 8 × 1.25	2.0 ~ 3.0	14.5 ~ 21.7	2.73 ~ 4.12	19.7 ~ 29.8
M10 × 1.5	4.0 ~ 6.0	28.9 ~ 43.4	5.5 ~ 8.3	39.8 ~ 60
M12 × 1.75	7.4 ~ 11.2	53.5 ~ 79.5	9.8 ~ 15.8	71 ~ 114
M14 × 2.0	12.2 ~ 16.6	88.2 ~ 120	16.7 ~ 22.5	121 ~ 167
M16 × 2.0	18.6 ~ 25.2	135 ~ 182	25.2 ~ 34.2	182 ~ 247
M18 × 2.5	25.8 ~ 35.0	187 ~ 253	35.1 ~ 47.5	254 ~ 343
M20 × 2.5	36.2 ~ 49.0	262 ~ 354	49.2 ~ 66.6	356 ~ 482
M22 × 2.5	48.3 ~ 63.3	350 ~ 457	65.8 ~ 98.0	476 ~ 709
M24 × 3.0	62.5 ~ 84.5	452 ~ 611	85.0 ~ 115	615 ~ 832
M30 × 3.5	124 ~ 168	898 ~ 1214	169 ~ 229	1223 ~ 1655
M36 × 4.0	174 ~ 236	1261 ~ 1703	250 ~ 310	1808 ~ 2242

#### (2) Fine thread

Bolt size	8T		10T	
	kgf · m	lbf · ft	kgf · m	lbf · ft
M 8 × 1.0	2.17 ~ 3.37	15.7 ~ 24.3	3.04 ~ 4.44	22.0 ~ 32.0
M10 × 1.25	4.46 ~ 6.66	32.3 ~ 48.2	5.93 ~ 8.93	42.9 ~ 64.6
M12 × 1.25	7.78 ~ 11.6	76.3 ~ 83.7	10.6 ~ 16.0	76.6 ~ 115
M14 × 1.5	13.3 ~ 18.1	96.2 ~ 130	17.9 ~ 24.1	130 ~ 174
M16 × 1.5	19.9 ~ 26.9	144 ~ 194	26.6 ~ 36.0	193 ~ 260
M18 × 1.5	28.6 ~ 43.6	207 ~ 315	38.4 ~ 52.0	278 ~ 376
M20 × 1.5	40.0 ~ 54.0	289 ~ 390	53.4 ~ 72.2	386 ~ 522
M22 × 1.5	52.7 ~ 71.3	381 ~ 515	70.7 ~ 95.7	512 ~ 692
M24 × 2.0	67.9 ~ 91.9	491 ~ 664	90.9 ~ 123	658 ~ 890
M30 × 2.0	137 ~ 185	990 ~ 1338	182 ~ 248	1314 ~ 1795
M36 × 3.0	192 ~ 260	1389 ~ 1879	262 ~ 354	1893 ~ 2561

**2) PIPE AND HOSE(FLARE TYPE)**

Thread size(PF)	Width across flat(mm)	kgf · m	lbf · ft
1/4"	19	4	28.9
3/8"	22	5	36.2
1/2"	27	6	43.4
3/4"	36	12	86.8
1"	41	14	101

**3) PIPE AND HOSE(ORFS TYPE)**

Thread size(UNF)	Width across flat(mm)	kgf · m	lbf · ft
13/16-16"	24	4.4	32.5
1-3/16-12"	36	9.3	67.3
1-7/16-12"	41	13.2	95.5
1-11/16-12"	50	18.3	132.4
2-12"	55	22.6	163.5

**4) FITTING**

Thread size(PF)	Width across flat(mm)	kgf · m	lbf · ft
1/4"	19	4	28.9
3/8"	22	5	36.2
1/2"	27	6	43.4
3/4"	36	13	94.0
1"	41	15	109

## 7. RECOMMENDED LUBRICANTS

Use only oils listed below or equivalent.

Do not mix different brand oil.

Service point	Kind of fluid	Capacity (U.S. gal)	Ambient temperature °C(°F)						
			-20 (-4)	-10 (14)	0 (32)	10 (50)	20 (68)	30 (86)	40 (104)
Engine oil pan	Engine oil	11(2.9)	SAE 30						
			SAE 10W						
			SAE 10W-30						
			SAE 15W-40						
Torque converter Transmission	Oil	20(5.3)	SAE 10W-30						
			SAE 15W-40						
Axle	Gear oil	Front : 18.4(4.9) Rear : 18.4(4.9)	SAE 80W-90LSD/API GL-5						
Hydraulic tank	Hydraulic oil	Tank: 90(24) System: 125(33)	ISO VG 32						
			ISO VG 46						
			ISO VG 68						
Fuel tank	Diesel fuel	202(53)	ASTM D975 NO. 1						
			ASTM D975 NO. 2						
Fitting (Grease nipple)	Grease	As required	NLGI NO. 1						
			NLGI NO. 2						
Radiator	Mixture of antifreeze and water 50 : 50	30(7.9)	Ethylene glycol base permanent type						