

SECTION 6 WORK EQUIPMENT

Group 1 Structure and Function	6-1
Group 2 Operational Checks and Troubleshooting	6-59
Group 3 Tests and Adjustments	6-72
Group 4 Disassembly and Assembly	6-86

SECTION 6 WORK EQUIPMENT

GROUP 1 STRUCTURE AND FUNCTION

1. HYDRAULIC SYSTEM OUTLINE

The loader and backhoe hydraulic system is a open center system which is supplied with flow from the fixed displacement double gear pump.

The backhoe hydraulic system is a pilot operated and the loader hydraulic system is operated by linkage.

Oil is drawn from the hydraulic tank by the hydraulic pump. The pump has two sections, P1 and P2.

The hydraulic pump is mounted on the rear of the transmission and is driven by the engine via a driveshaft.

Oil from pump section P2 flows direct to the loader control valve. Oil from the large section P1, flows to steering unit, and in neutral circuit flows through the priority valve in pump to the loader control valve and then to join the flow from P2 at the loader control valve.

From the loader control valve neutral gallery, oil flows via a high pressure carry-over line to the backhoe valve.

Some of the exhaust oil flows directly back to the tank through a filter and some of the exhaust oil returns to tank via the hydraulic oil cooler.

To help prevent backhoe dipper cylinder and loader lift cylinder cavitation, there is a check valve fitted to the return line. The check valve raises approximately 5 bar (75 lbf/in²) of pressure in the line, which improves the operation of the respective anti-cavitation valves.

The hydraclamp exhaust hose is fitted. The hose connects the hydraclamp spool directly into the exhaust circuit. This prevents the clamp from **locking-up** when the sideshifting operation is required.

2. HYDRAULIC CIRCUIT

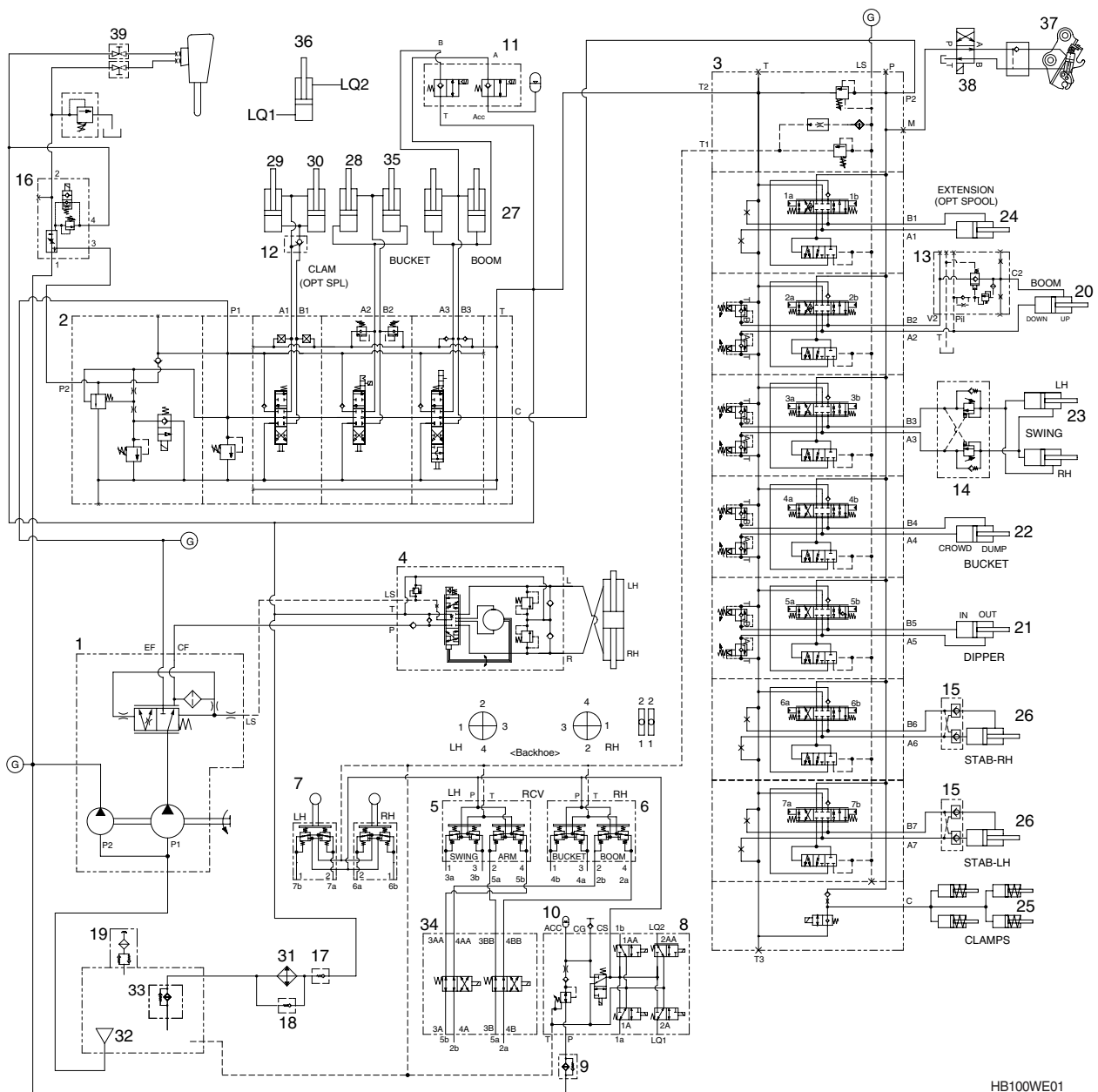

HB100WE01

- | | | | | | |
|----|---|----|---------------------------|----|-------------------------------|
| 1 | Main pump | 14 | Swing damping valve (opt) | 28 | Loader bucket cylinder-LH |
| 2 | Main control valve (loader) | 15 | Double pilot check valve | 29 | Clam cylinder-LH (opt) |
| 3 | Main control valve (backhoe) | 16 | Breaker valve (opt) | 30 | Clam cylinder-RH (opt) |
| 4 | Steering unit | 17 | Return check valve | 31 | Oil cooler |
| 5 | Remote control valve-LH | 18 | By-pass check valve | 32 | Suction strainer |
| 6 | Remote control valve-RH | 19 | Air breather | 33 | Return filter |
| 7 | Stabilizer lever | 20 | Boom cylinder | 34 | Pattern exchanger valve (opt) |
| 8 | Pilot supply unit
5- cartridge sol valve (opt) | 21 | Dipper cylinder | 35 | Loader bucket cylinder-RH |
| 9 | Line filter | 22 | Bucket cylinder | 36 | Quick coupler-loader |
| 10 | Accumulator | 23 | Swing cylinder | 37 | Quick coupler-backhoe |
| 11 | Ride control valve (opt) | 24 | Extension cylinder (opt) | 38 | Solenoid valve |
| 12 | Pilot check valve (opt) | 25 | Clamp cylinder | 39 | Stop valve (opt) |
| 13 | Safety lock valve (opt) | 26 | Stabilizer cylinder | ⓐ | Gauge port |
| | | 27 | Loader boom cylinder | | |

3. LOADER HYDRAULIC CIRCUIT

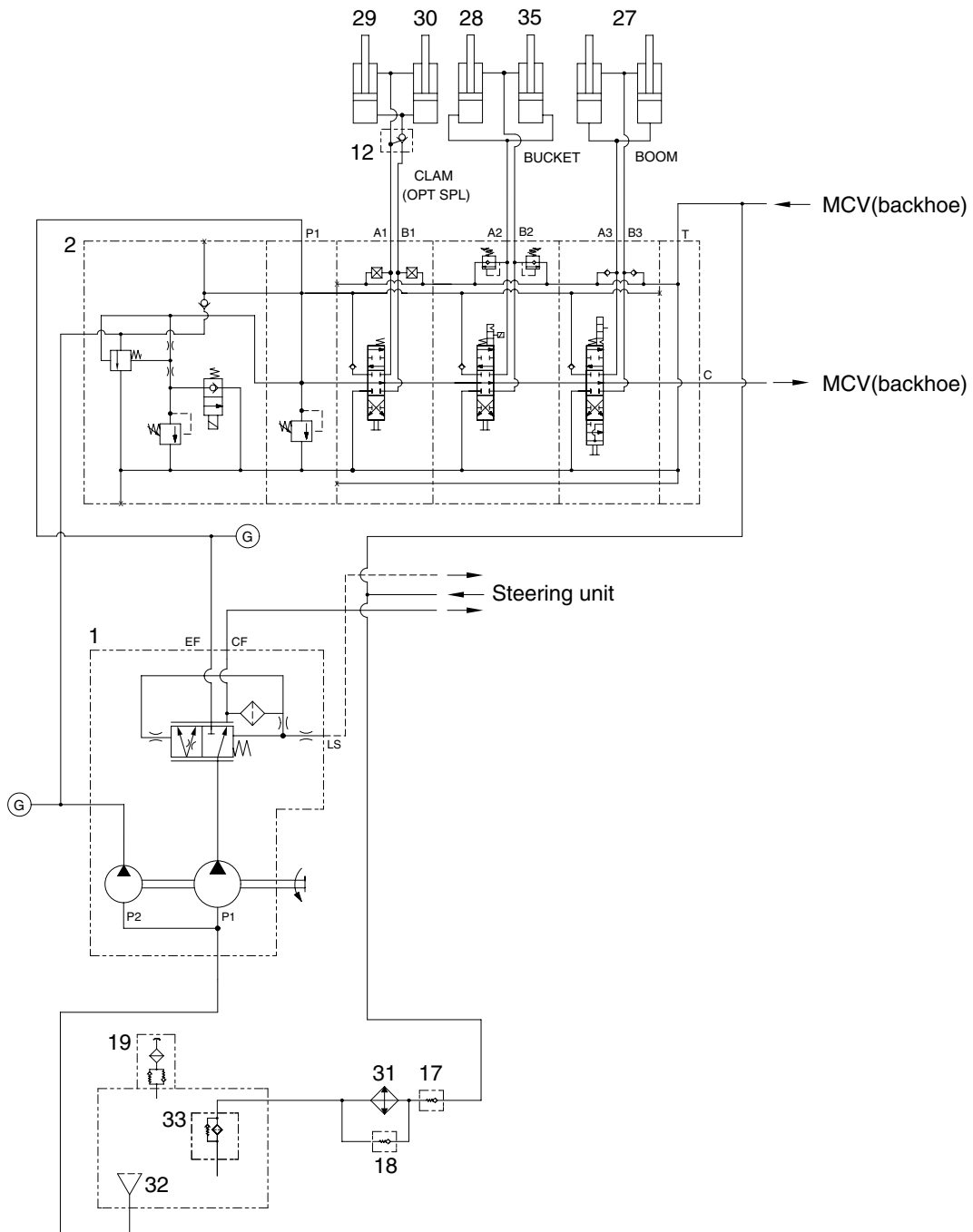

HB100WE02

- | | | | | | |
|----|-----------------------------|----|---------------------------|----|---------------------------|
| 1 | Main pump | 19 | Air breather | 31 | Oil cooler |
| 2 | Main control valve (loader) | 27 | Loader boom cylinder | 32 | Suction strainer |
| 12 | Pilot check valve (opt) | 28 | Loader bucket cylinder-LH | 33 | Return filter |
| 17 | Return check valve | 29 | Clam cylinder-LH | 35 | Loader bucket cylinder-RH |
| 18 | By-pass check valve | 30 | Clam cylinder-RH | ⓐ | Gauge port |

1) WHEN THE RCV LEVER IS IN THE RAISE POSITION

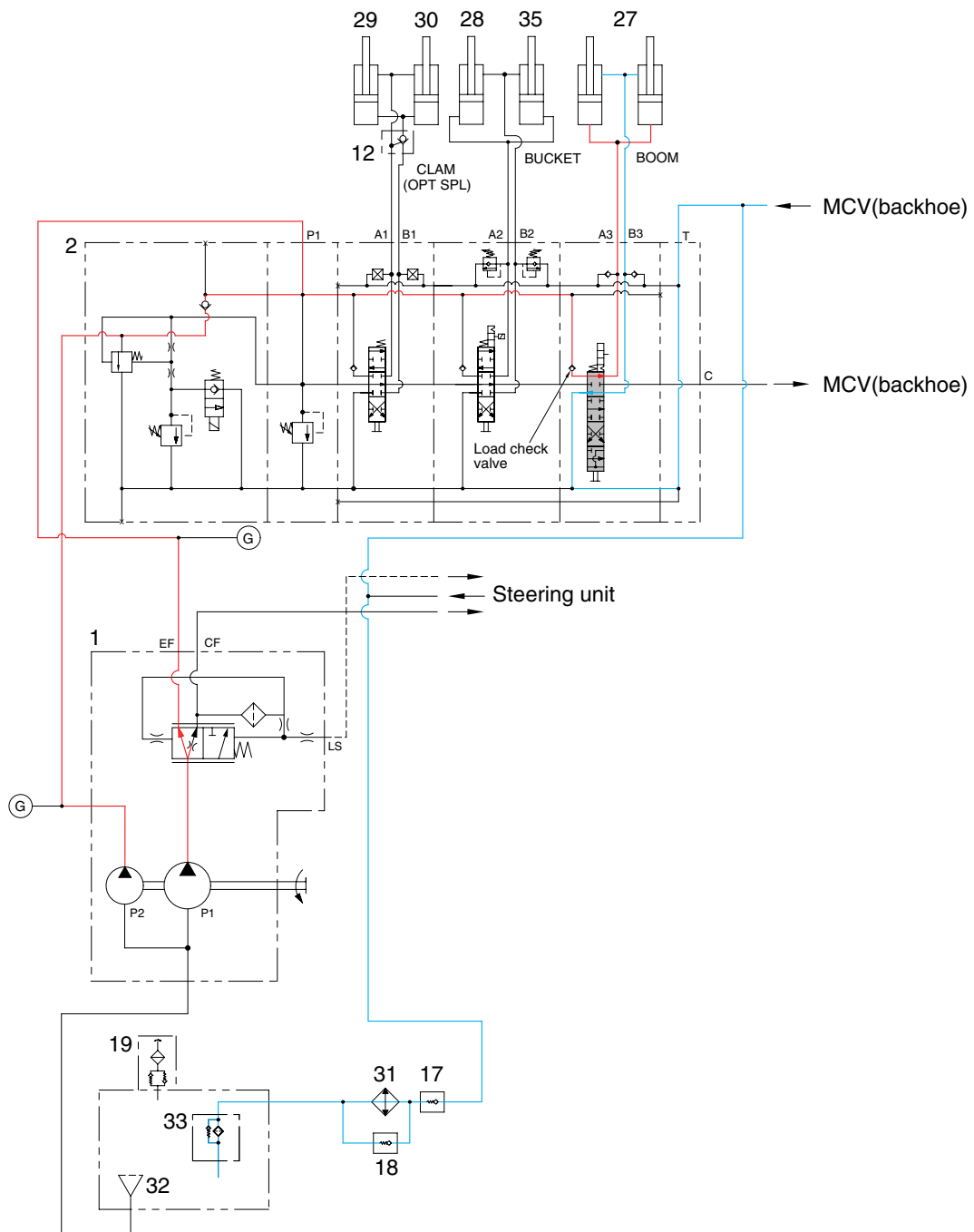

HB100WE03

- When the loader RCV lever is pulled back, the boom spool is moved to raise position.
- The oil from main pump (1) flows into loader main control valve (2) and then goes to the large chamber of boom cylinder (27) by pushing the load check valve of the boom spool.
- The oil from the small chamber of boom cylinder (27) returns to hydraulic oil tank through the boom spool at the same time.
- When this happens, the boom goes up.

2) WHEN THE RCV LEVER IS IN THE LOWER POSITION

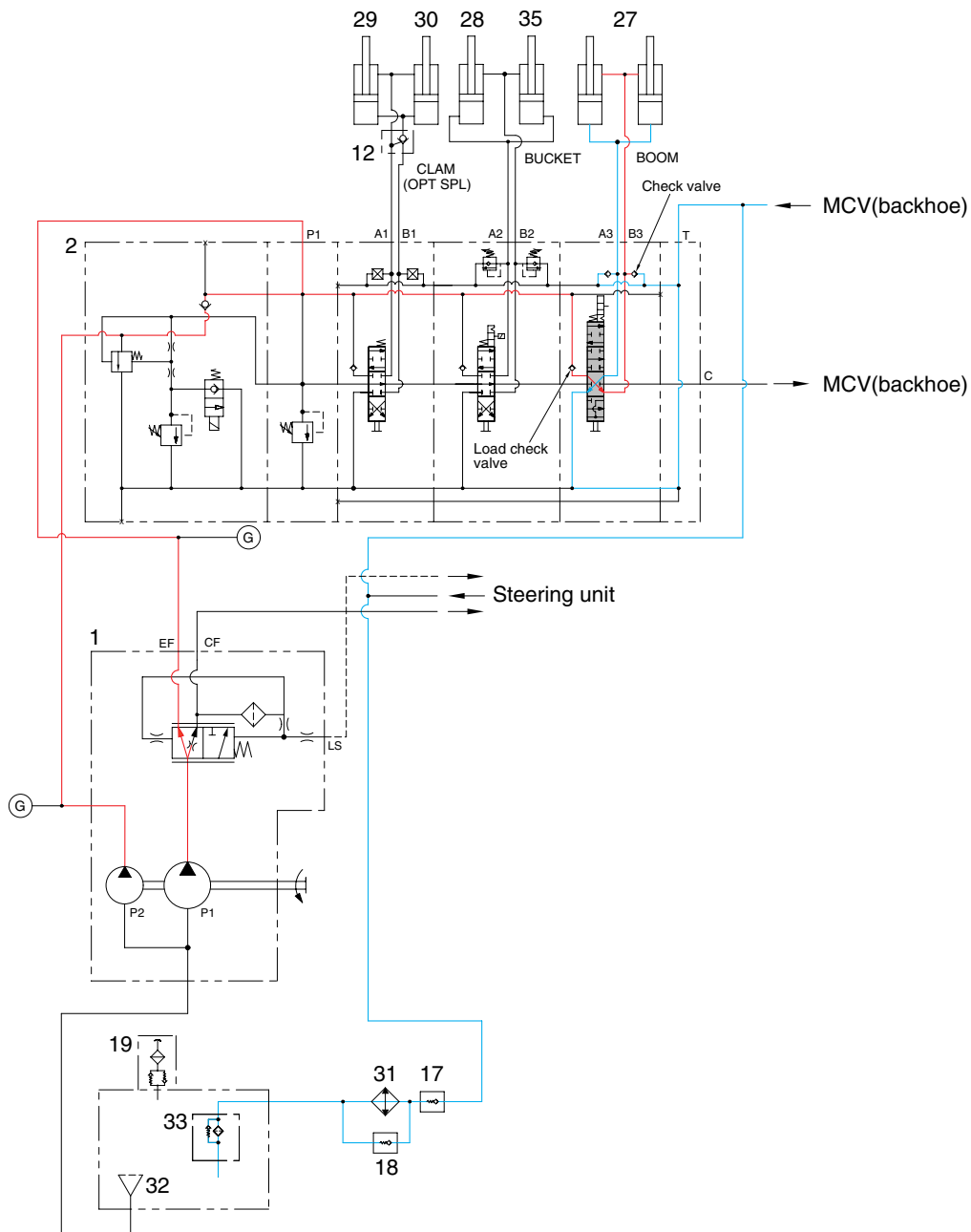

HB100WE04

- When the loader RCV lever is pushed forward, the boom spool is moved to lower position.
- The oil from main pump (1) flows into loader main control valve (2) and then goes to small chamber of boom cylinder (27) by pushing the load check valve of the boom spool.
- The oil returned from large chamber of boom cylinder (27) returns to hydraulic tank through the boom spool at the same time.
- When the lowering speed of boom is faster, the return oil from the large chamber of boom cylinder combines with the oil from the pump through the check valve, and flows into the small chamber of the cylinder.

This prevents cylinder cavitation by the negative pressure when the pump flow cannot match the boom down speed.

3) WHEN THE RCV LEVER IS IN THE FLOAT POSITION

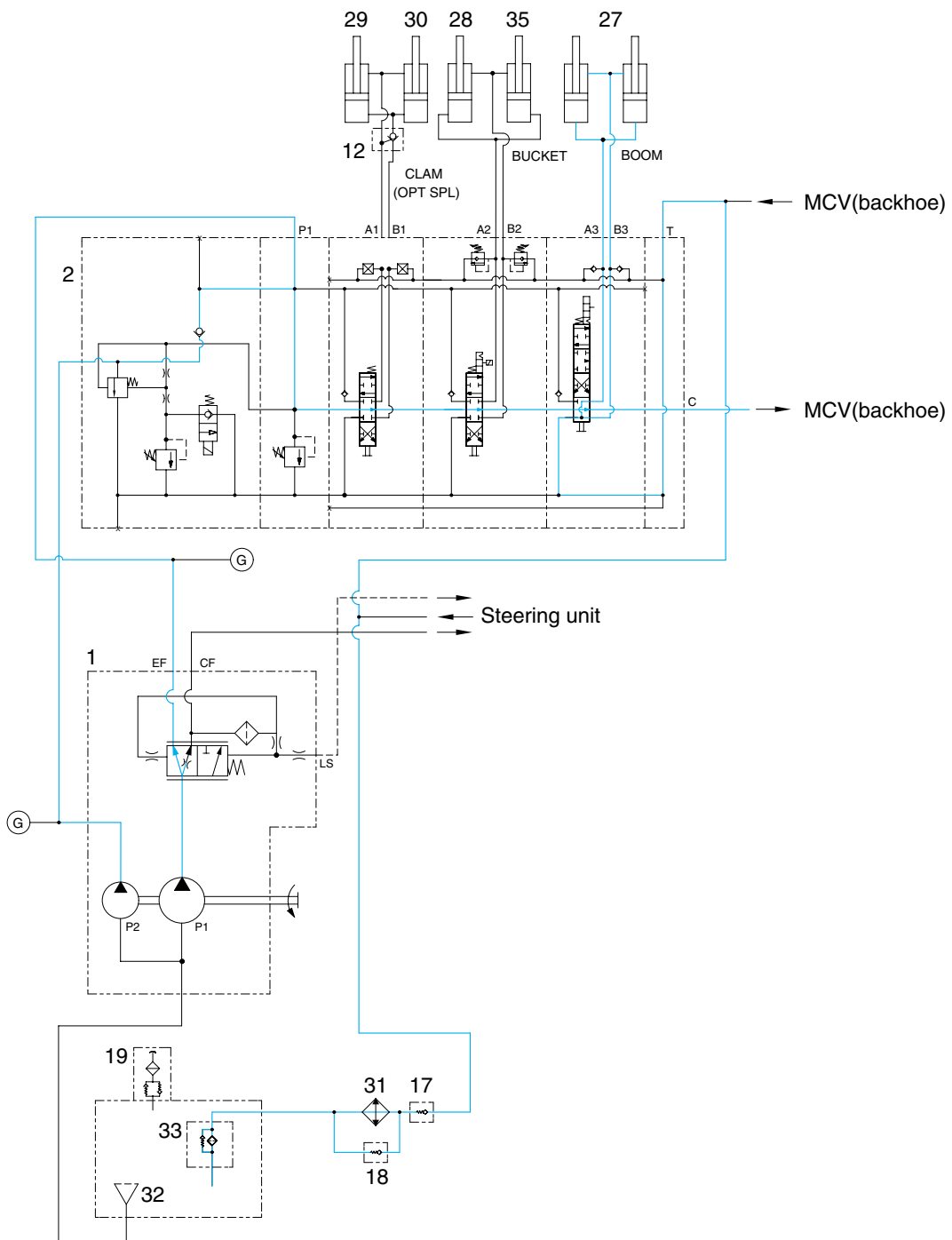

HB100WE05

- When the loader RCV lever is pushed further forward from the lower position, the boom spool is moved to floating position.
- The work ports (A3), (B3) and the small chamber and the large chamber are connected to the return passage, so the boom will be lowered due to it's own weight.
- In this condition, when the bucket is in contact with the ground, it can be move up and down in accordance with the shape of the ground.

4) WHEN THE RCV LEVER IS IN THE DUMP POSITION

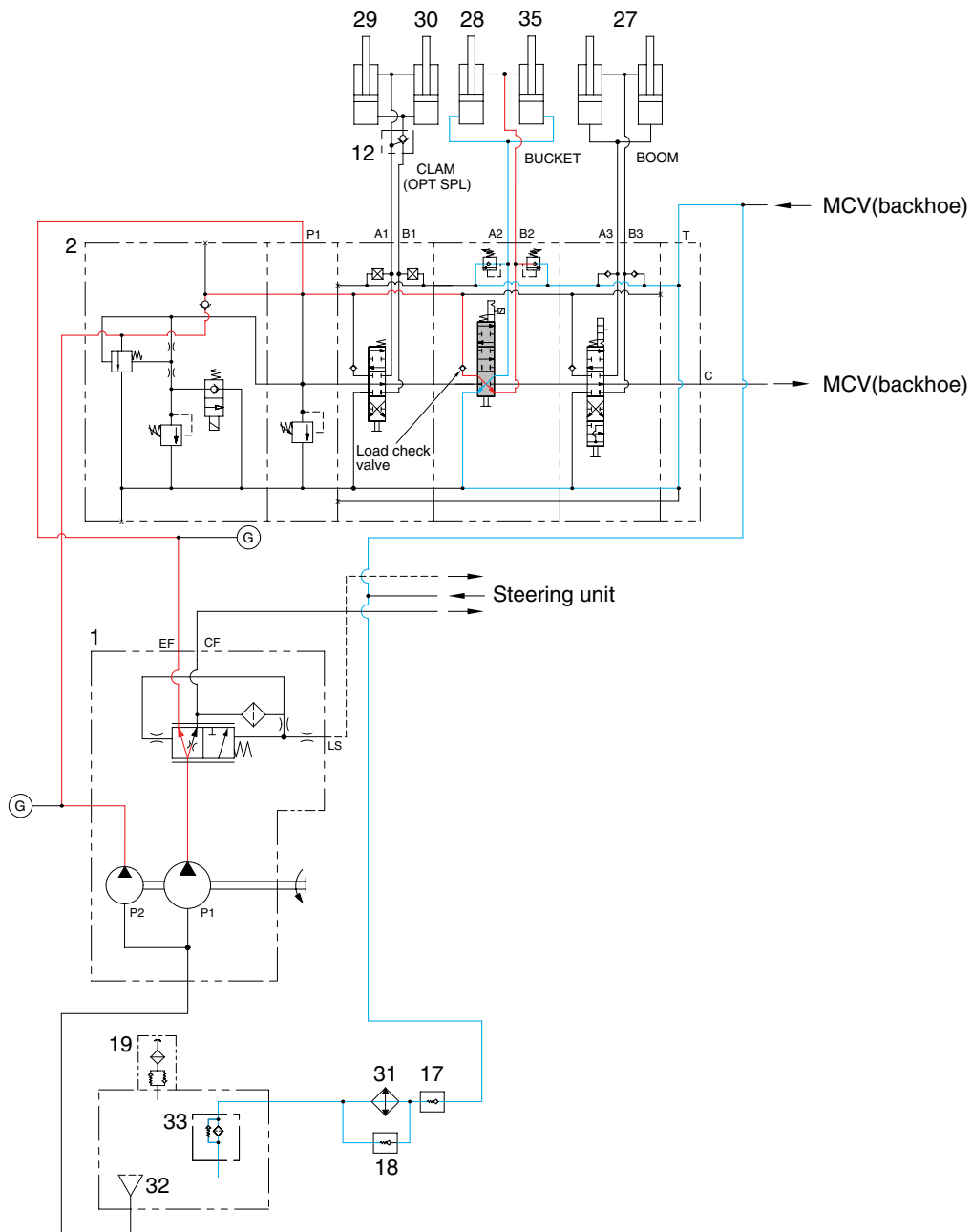

HB100WE07

- If the loader RCV lever is pushed right, the bucket spool is moved to dump position.
- The oil from main pump (1) flows into loader main control valve (2) and then goes to the small chamber of bucket cylinder (28, 35) by pushing the load check valve of the bucket spool.
- The oil at the large chamber of bucket cylinder (28, 35) returns to hydraulic tank through the bucket spool.
- When this happens, the bucket is dumped.
- When the dumping speed of bucket is faster, the oil returned from the large chamber of bucket cylinder combines with the oil from the pump, and flows into the small chamber of the cylinder. This prevents cylinder cavitation by the negative pressure when the pump flow cannot match the bucket dump speed.

5) WHEN THE RCV LEVER IS IN THE ROLL BACK (retract) POSITION

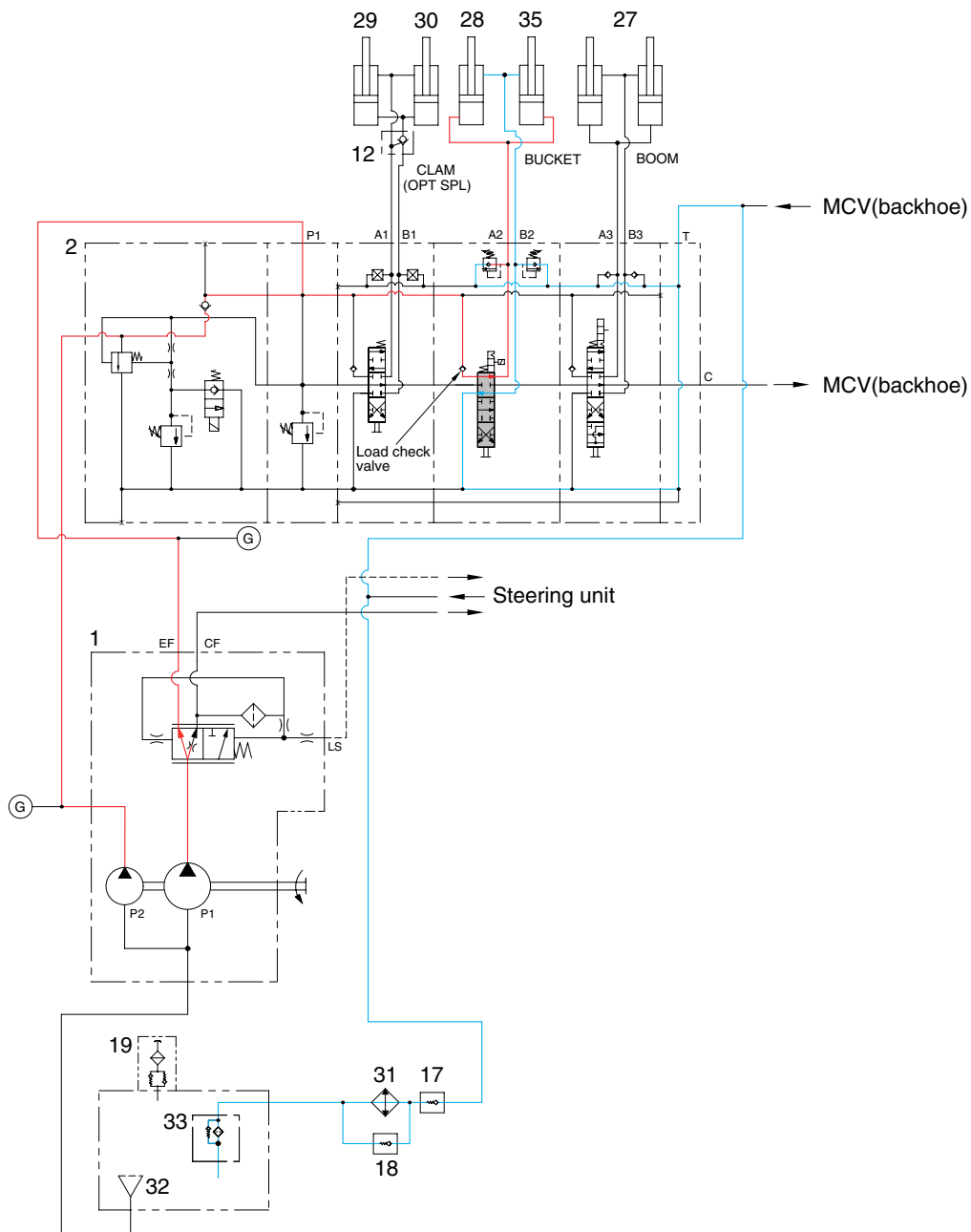

HB100WE06

- If the loader RCV lever is pulled left, the bucket spool is moved to roll back position.
- The oil from main pump (1) flows into loader main control valve (2) and then goes to the large chamber of bucket cylinder (28, 35) by pushing the load check valve of the bucket spool.
- The oil at the small chamber of bucket cylinder (28, 35) returns to hydraulic tank.
- When this happens, the bucket roll back.
- When the rolling speed of bucket is faster, the return oil from the small chamber of bucket cylinder combines with the oil from the pump, and flows into the large chamber of the cylinder. This prevents cylinder cavitation by the negative pressure when the pump flow cannot match the bucket rolling speed.

6) LOW SPEED CONTROL FUNCTION

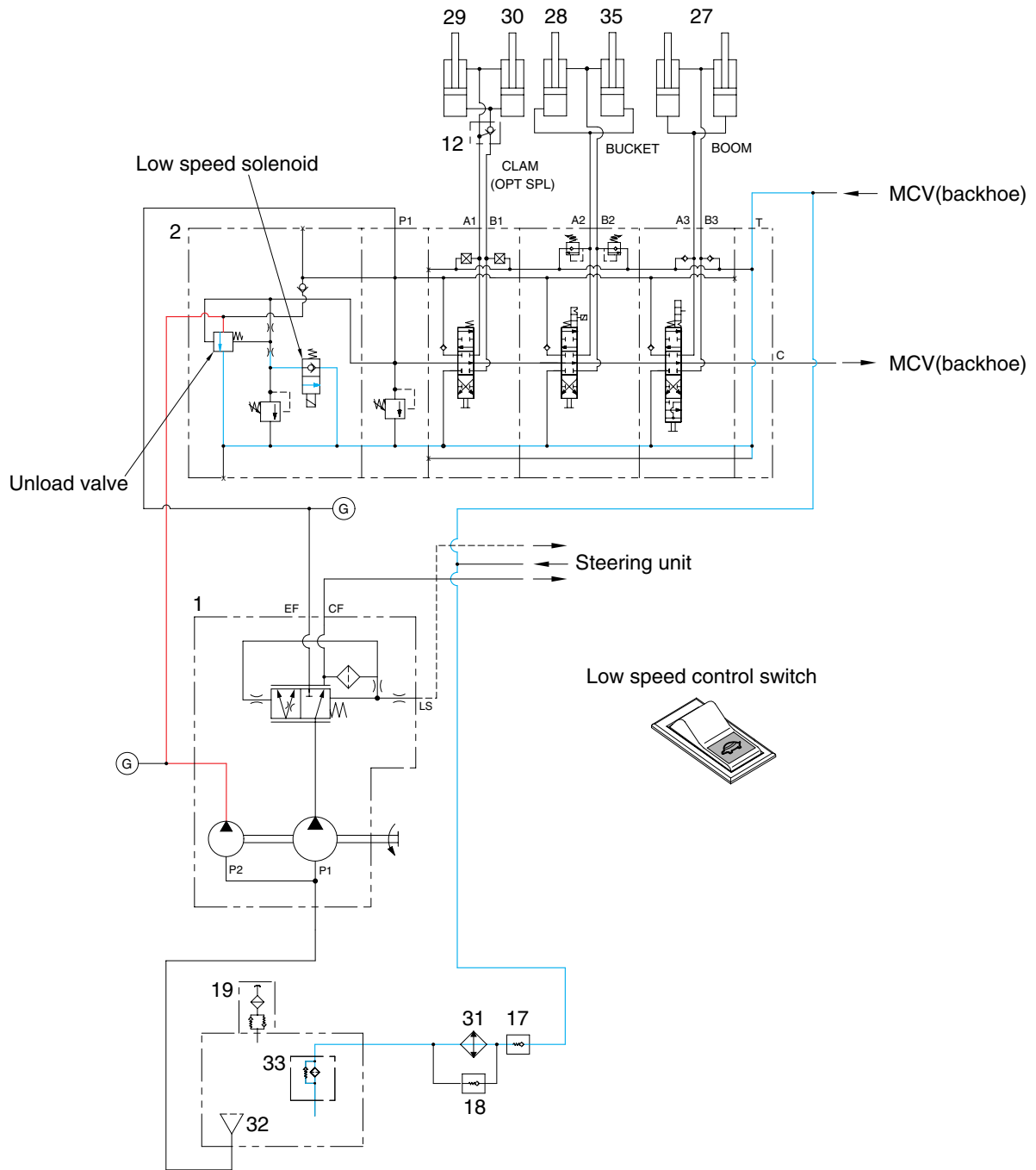

HB100WE06-1

- If the low speed control switch is pushed ON, the low speed solenoid is energized . Then unload valve is opened and the oil from P2 pump return to the tank. This makes loader speed slow.

7) RIDE CONTROL FUNCTION (OPTION)

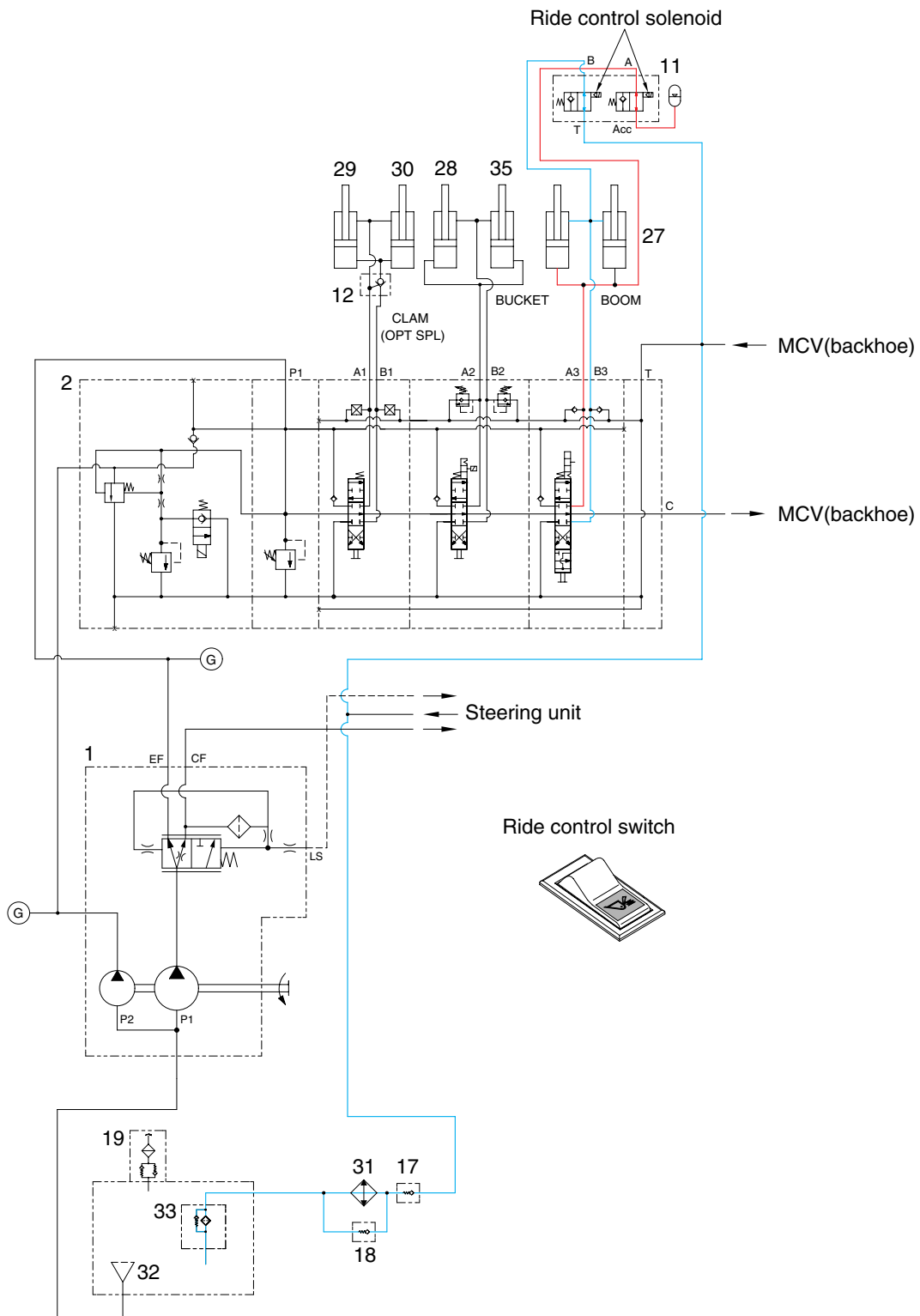

HB100WE147

- When the ride control switch is operated, the solenoids on the ride control valve (11) are energized. Hydraulic oil from the large chamber of boom cylinder is dead ended at the loader control valve and is connected to the accumulator. Hydraulic oil from the small chamber of boom cylinder is connected to tank to make up or dissipate oil as required.

4. BACKHOE HYDRAULIC CIRCUIT

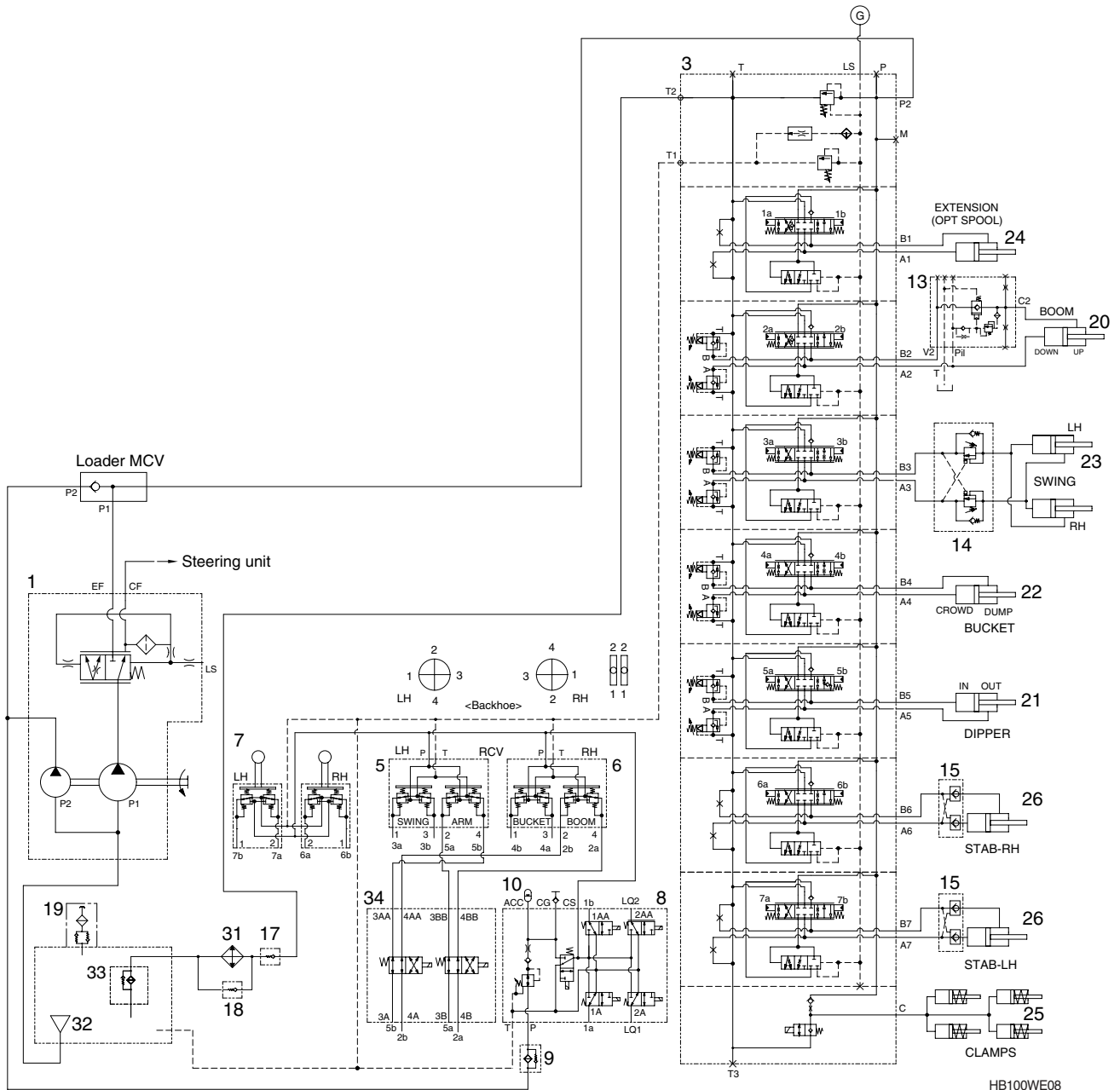

HB100WE08

- | | | | | | |
|----|------------------------------|----|---------------------------|----|------------------------------|
| 1 | Main pump | 13 | Safety lock valve (opt) | 23 | Swing cylinder |
| 3 | Main control valve (backhoe) | 14 | Swing damping valve (opt) | 24 | Extension cylinder (opt) |
| 5 | Remote control valve-LH | 15 | Double pilot check valve | 25 | Clamp cylinder |
| 6 | Remote control valve-RH | 17 | Return check valve | 26 | Stabilizer cylinder |
| 7 | Stabilizer lever | 18 | By-pass check valve | 31 | Oil cooler |
| 8 | Pilot supply unit | 19 | Air breather | 32 | Suction strainer |
| | 5- cartridge sol valve (opt) | 20 | Boom cylinder | 33 | Return filter |
| 9 | Line filter | 21 | Dipper cylinder | 34 | Pattern exchange valve (opt) |
| 10 | Accumulator | 22 | Bucket cylinder | Ⓒ | Gauge port |

1) BOOM UP OPERATION

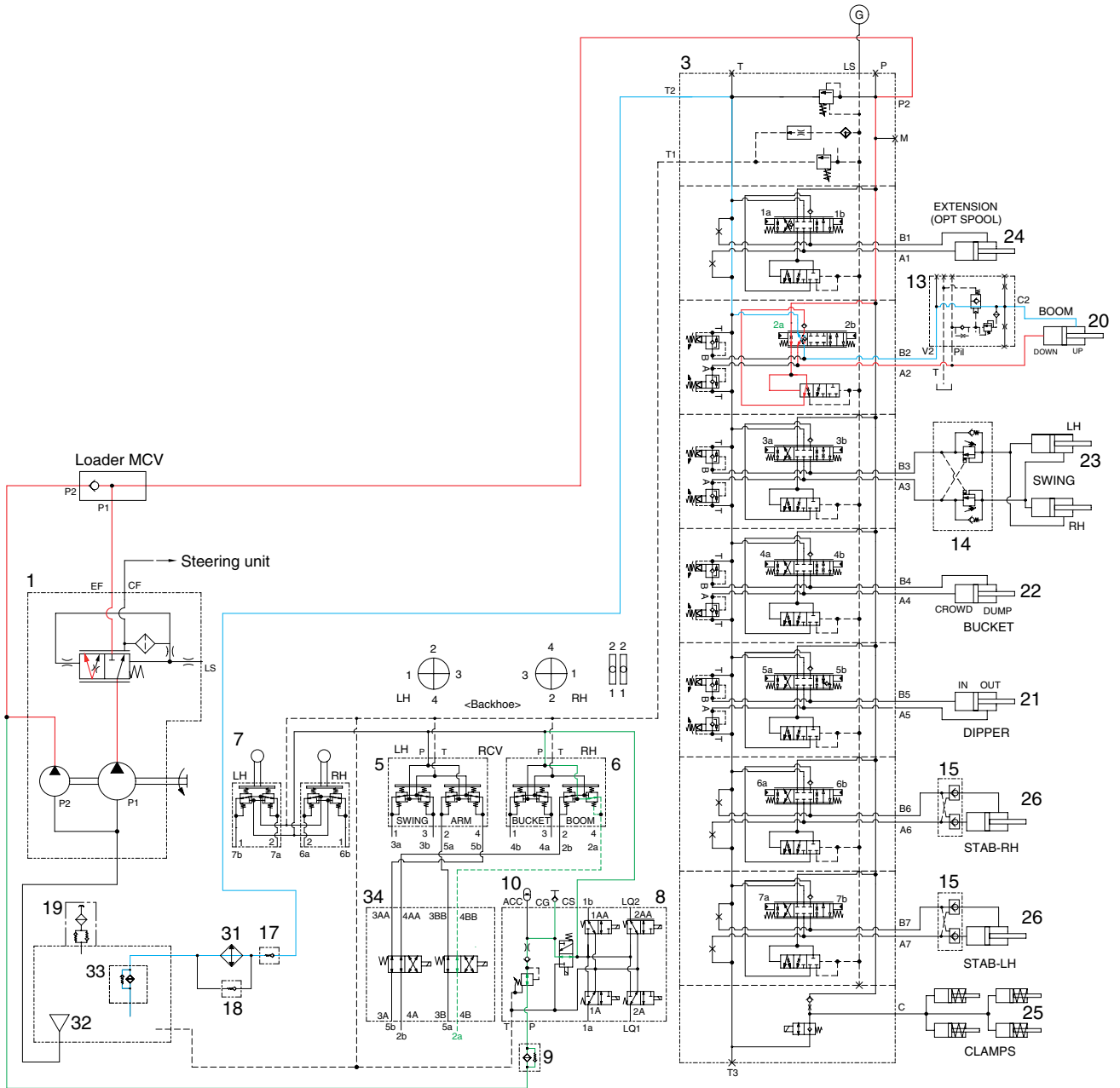

HB100WE09

When the backhoe right control lever is pulled back, the boom spool in the main control valve (3) is moved to the up position by the pilot oil pressure from the remote control valve (6). The oil from the pump (P1, P2) flows into the main control valve and then goes to the large chamber of boom cylinders. At the same time, the oil from the small chamber of boom cylinders returns to the hydraulic oil tank through the boom spool in the main control valve. When this happens, the boom goes up. The excessive pressure in the boom cylinder bottom end circuit is prevented by relief valve.

2) BOOM DOWN OPERATION

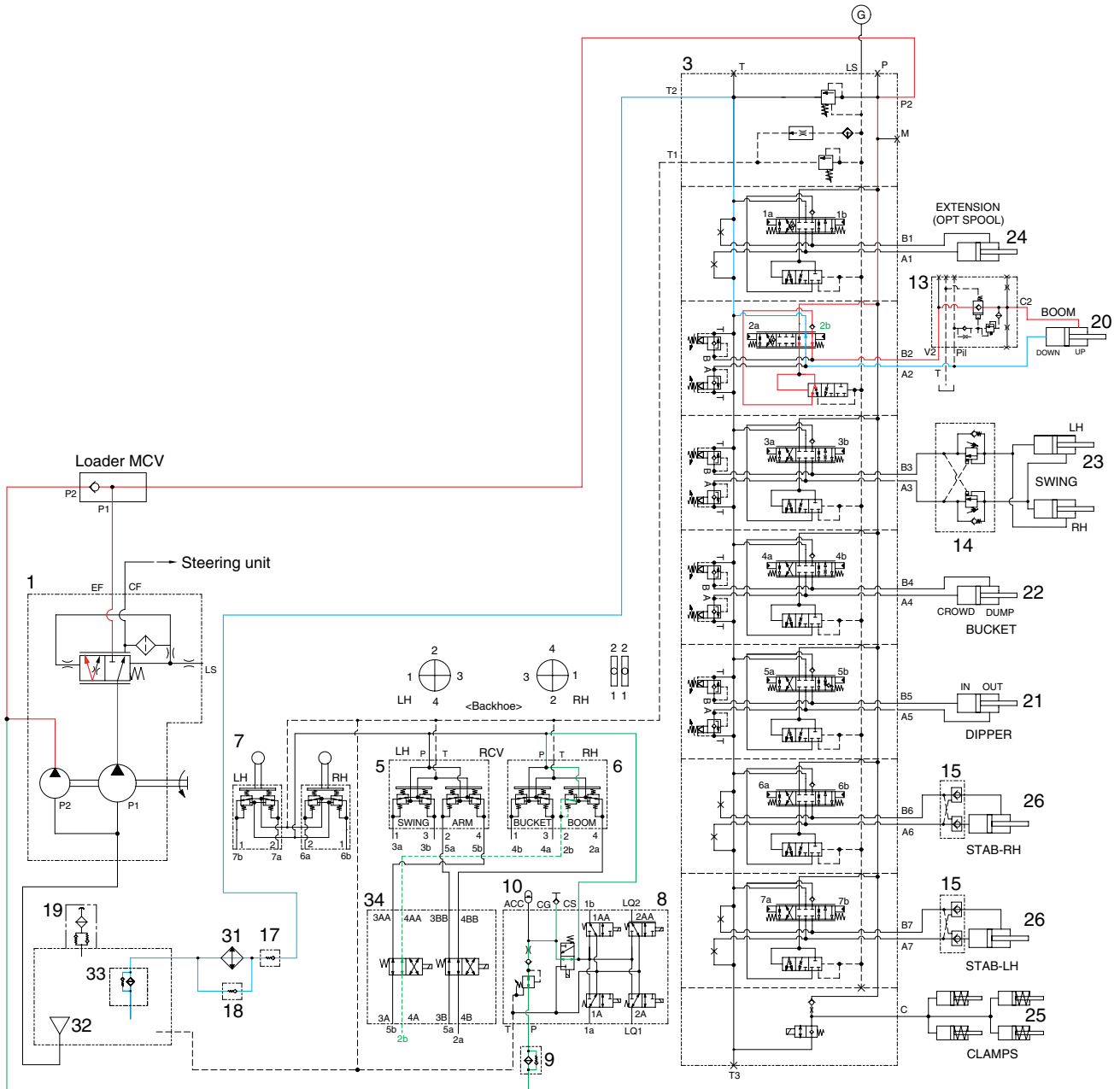

HB100WE10

When the backhoe right control lever is pushed forward, the boom spool in the main control valve (3) is moved to the down position by the pilot oil pressure from the remote control valve (6).

The oil from the pump (P1, P2) flows into the main control valve and then goes to the small chamber of boom cylinders. At the same time, the oil from the large chamber of boom cylinders returns to the hydraulic tank through the boom spool in the main control valve.

The excessive pressure in the boom cylinder rod end circuit is prevented by the relief valve.

3) DIPPER ROLL IN OPERATION

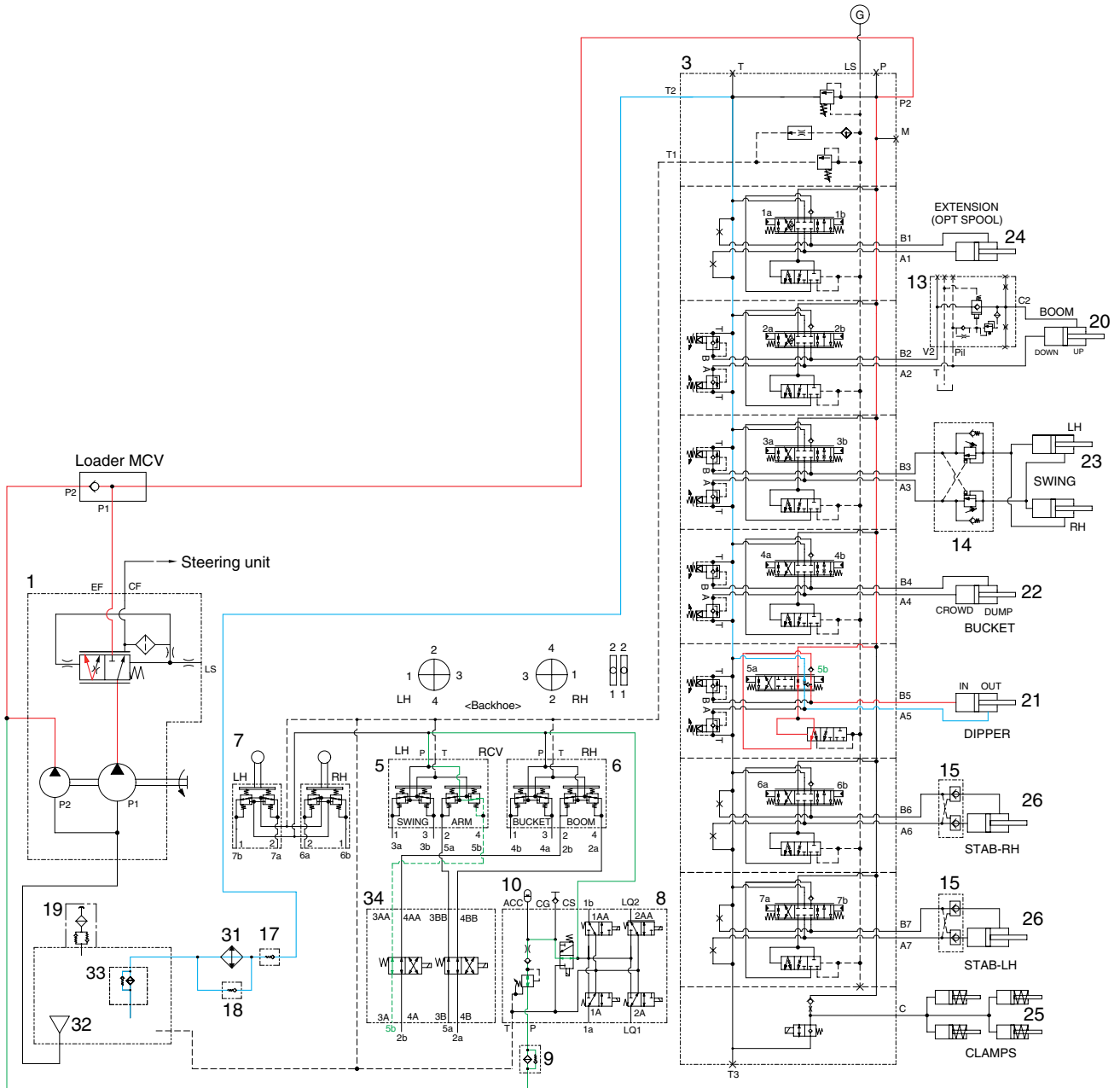

HB100WE11

When the backhoe left control lever is pulled back, the dipper spool in the main control valve (3) is moved to the roll in position by the pilot oil pressure from the remote control valve (5).

The oil from the pump (P1, P2) flows into the main control valve and then goes to the large chamber of dipper cylinder.

At the same time, the oil from the small chamber of dipper cylinder returns to the hydraulic oil tank through the dipper spool in the main control valve. When this happens, the dipper rolls in.

4) DIPPER ROLL OUT OPERATION

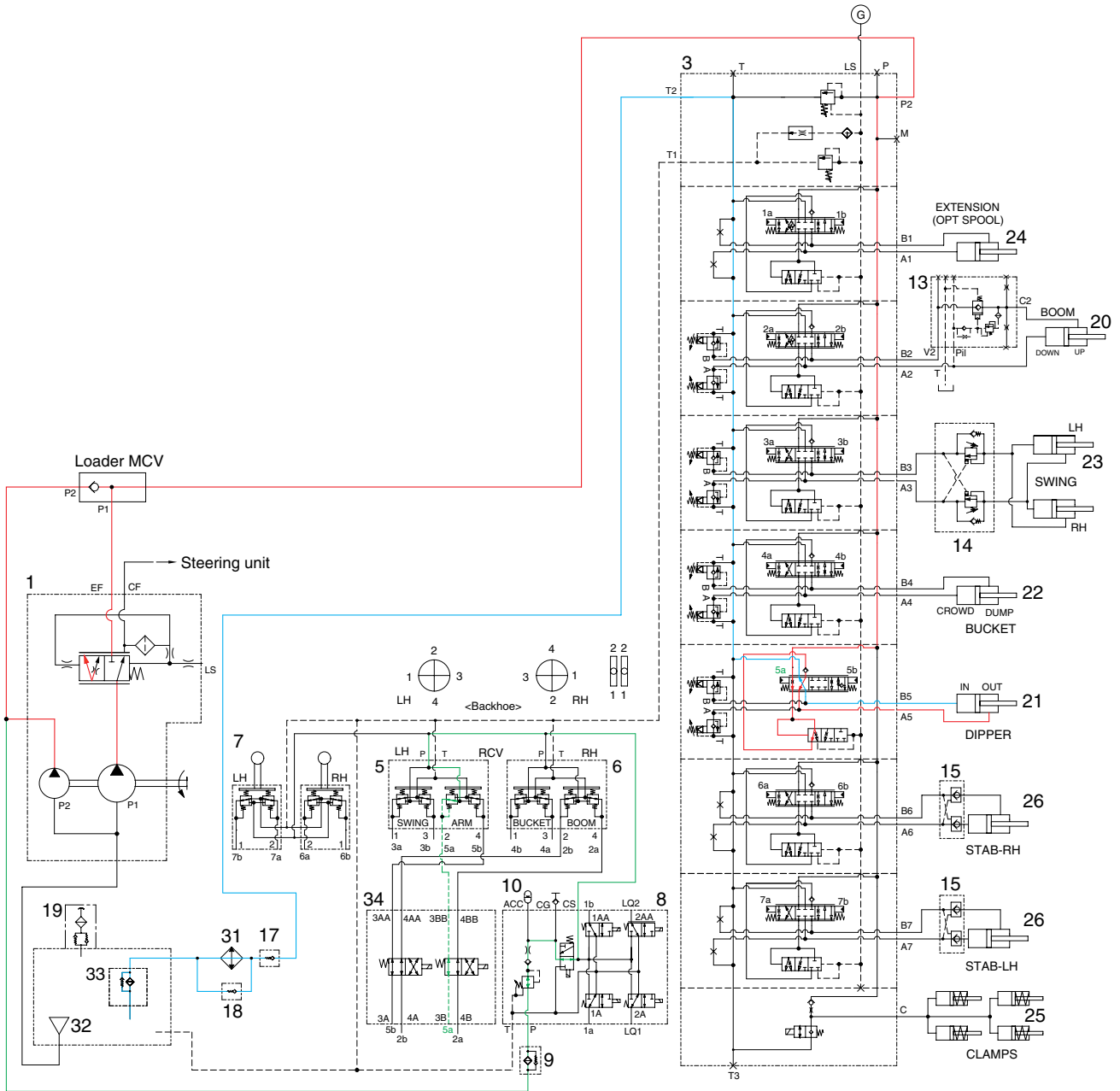

HB100WE12

When the backhoe left control lever is pushed forward, the dipper spool in the main control valve (3) is moved to the roll out position by the pilot oil pressure from the remote control valve (5).

The oil from the pump (P1, P2) flows into the main control valve and then goes to the small chamber of dipper cylinder.

At the same time, the oil from the large chamber of dipper cylinder returns to the hydraulic oil tank through the dipper spool in the main control valve. When this happens, the dipper rolls out.

5) BUCKET CROWD OPERATION

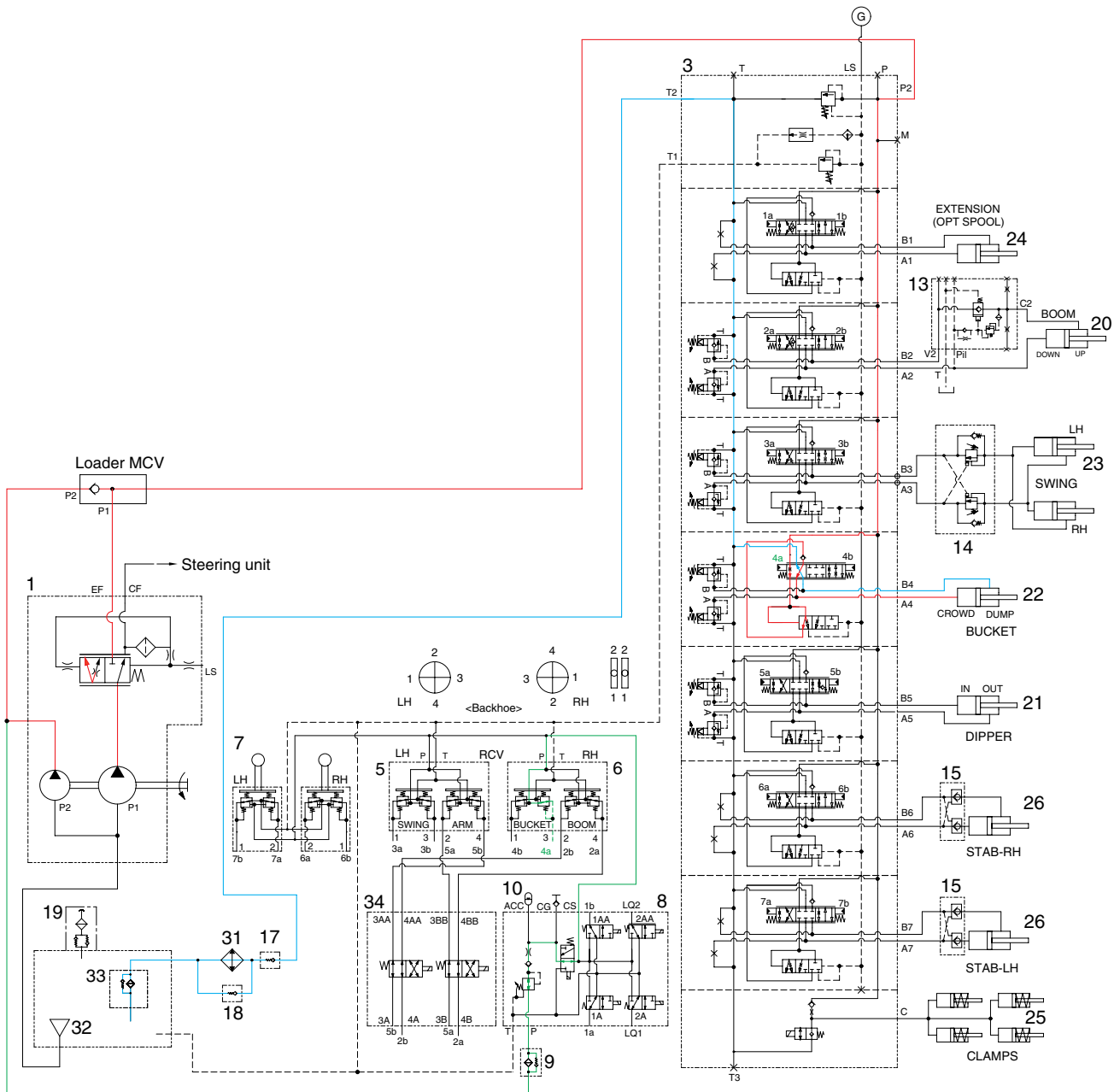

HB100WE13

When the backhoe right control lever is pulled left, the bucket spool in the main control valve (3) is moved to the crowd position by the pilot oil pressure from the remote control valve (6).

The oil from the pump (P1, P2) flows into the main control valve and then goes to the large chamber of bucket cylinder.

At the same time, the oil from the small chamber of bucket cylinder returns to the hydraulic oil tank through the boom spool in the main control valve. When this happens, the bucket crowd.

6) BUCKET DUMP OPERATION

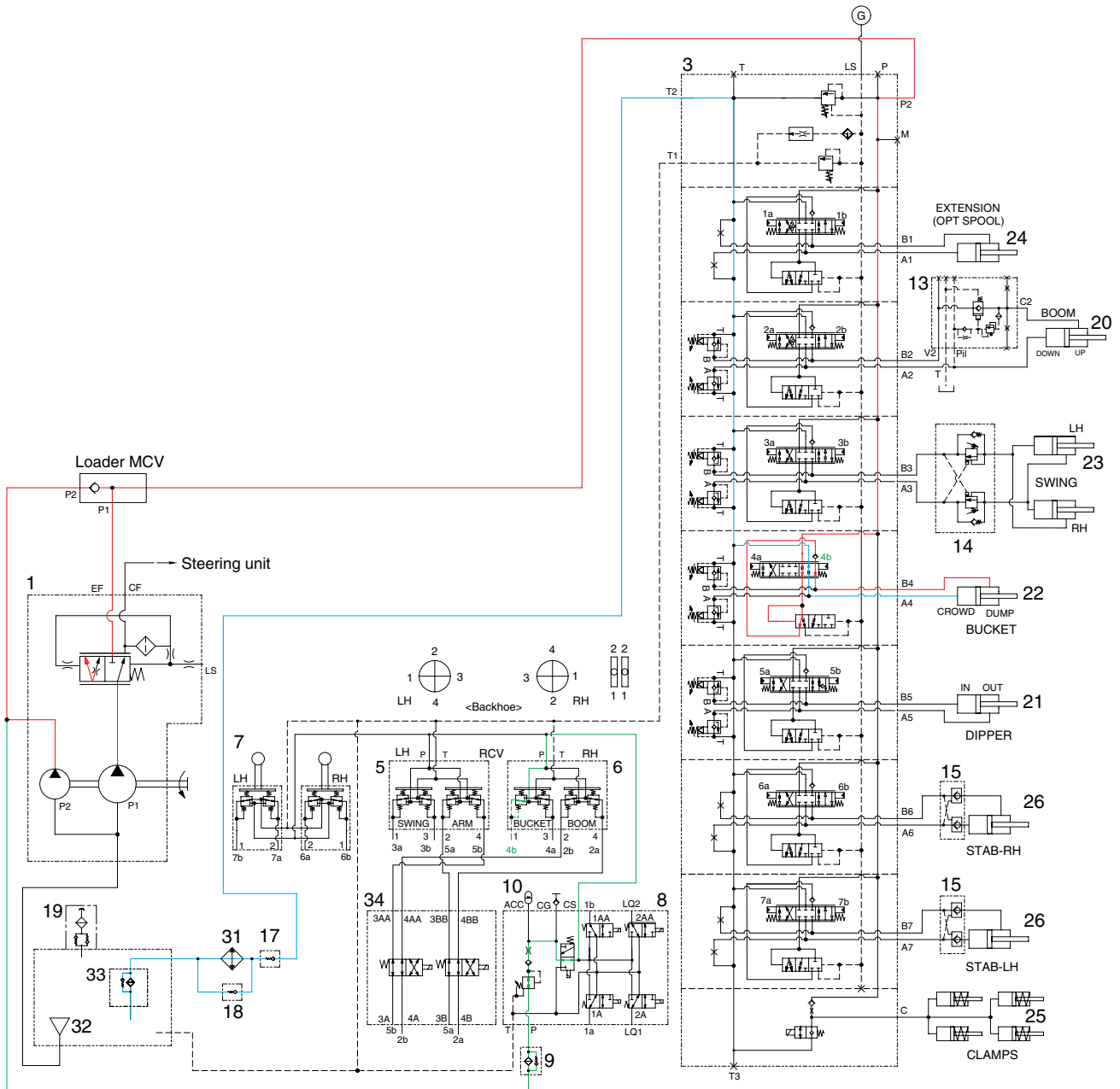

HB100WE14

When the backhoe right control lever is pushed right, the bucket spool in the main control valve (3) is moved to the dump position by the pilot oil pressure from the remote control valve (6).

The oil from the pump flows into the main control valve and then goes to the LS chamber of bucket cylinder.

At the same time, the oil from the large chamber of bucket cylinder returns to the hydraulic oil tank through the bucket spool in the main control valve. When this happens, the bucket dump.

7) BOOM SWING OPERATION

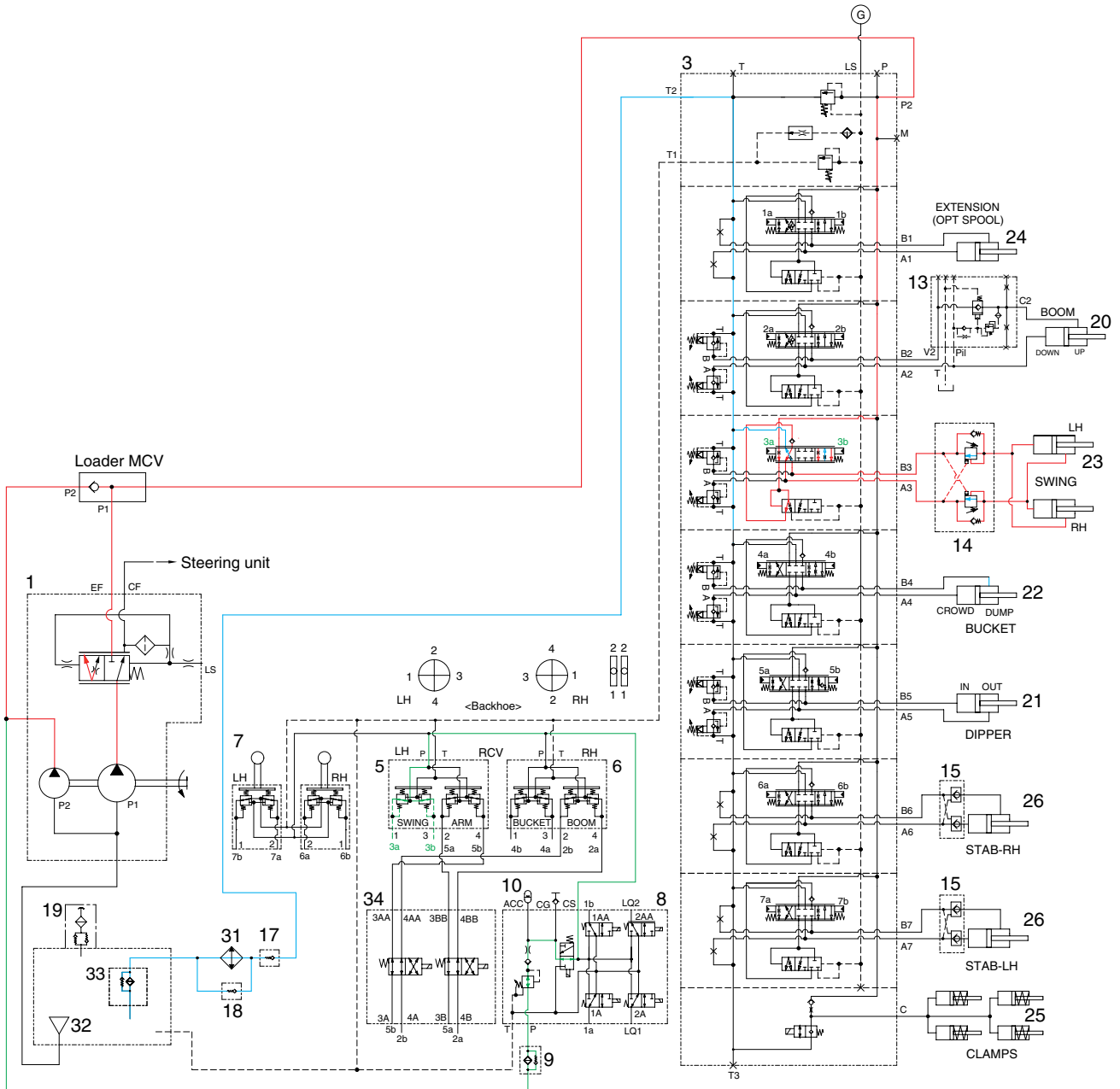

HB100WE15

When the backhoe left control lever is pushed left or right, the swing spool in the main control valve (3) is moved to the left or right swing position by the pilot oil pressure from the remote control valve (5). The oil from the pump (P1, P2) flows into the main control valve and then goes to the boom swing cylinder.

At the same time, the return oil from the boom swing cylinder returns to the hydraulic oil tank through the boom swing spool in the main control valve. When this happens, the boom swings to the left or right.

9) STABILIZER DOWN OPERATION

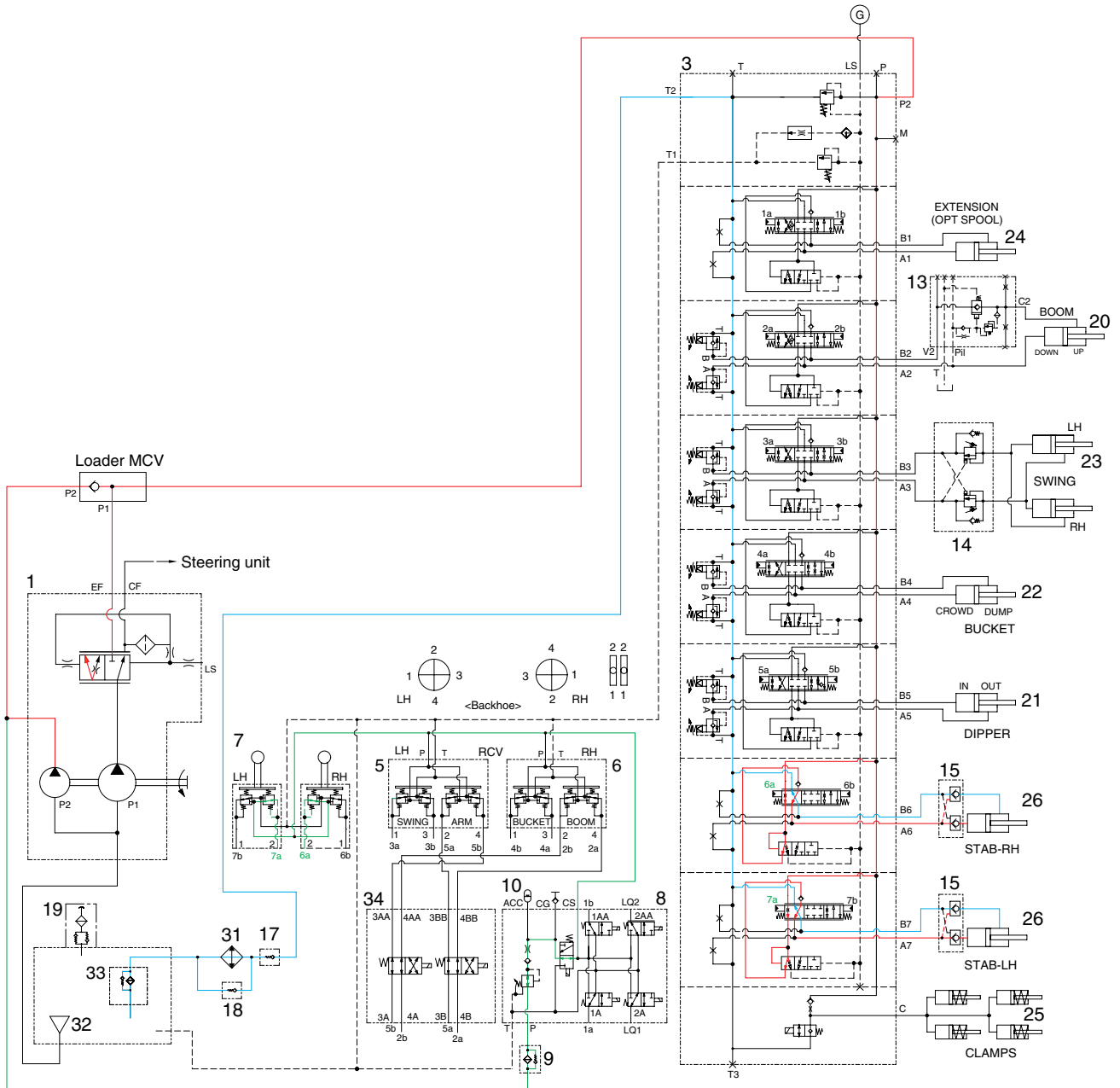

HB100WE17

When the stabilizer control levers (7) are pushed forward, the spools in the main control valve (3) are moved to the stabilizer down position by the pilot oil pressure from the remote control valve (7).

The oil from the pump (P1, P2) flows into the main control valve and then goes to the large chambers of stabilizer cylinders.

At the same time, the oil from the small chambers of stabilizer cylinders return to the hydraulic oil tank through the spools in the main control valve. When this happens, the stabilizers go down.

Each stabilizer (LH or RH) is operated separately.

5. MAIN PUMP

1) STRUCTURE (1/2)

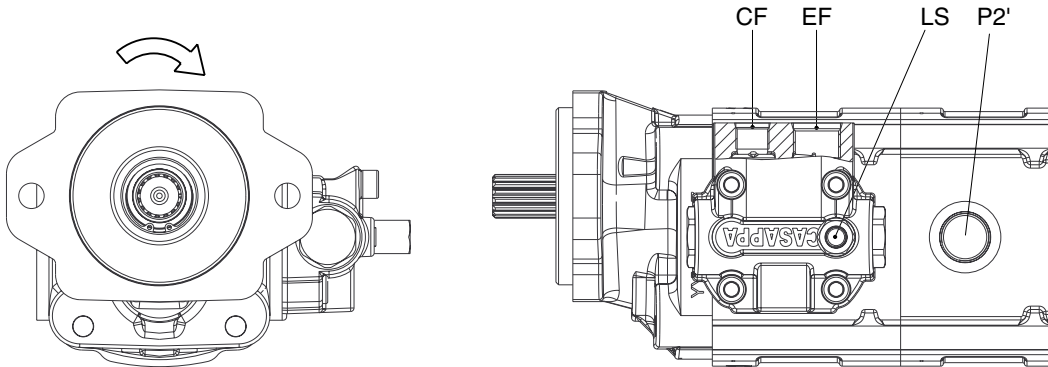

Port	Port name	Port size
CF	To steering unit	3/4-16 UNF
EF	To MCV	1-1/16-12 UN
LS	To steering unit LS port	7/16-20 UNF
P2'	To loader MCV	1-1/16-12 UN

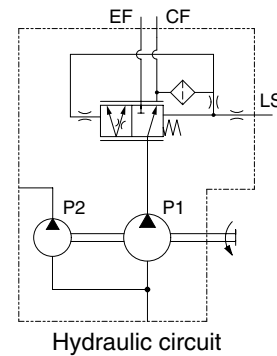

HB100WE20

Item		Specification	
		HB100	HB90
Type		Fixed displacement double gear pump	
Capacity	P1 pump	40 cc/rev	35 cc/rev
	P2 pump	35 cc/rev	35 cc/rev
Maximum operating pressure		250 kgf/cm ² (3560 psi)	
Rated oil quantity	P1 pump	88 l /min (23.3 U.S.gpm)	77 l /min (20.3 U.S.gpm)
	P2 pump	77 l /min (20.3 U.S.gpm)	77 l /min (20.3 U.S.gpm)
Rated speed		2200 rpm	

STRUCTURE (2/2)

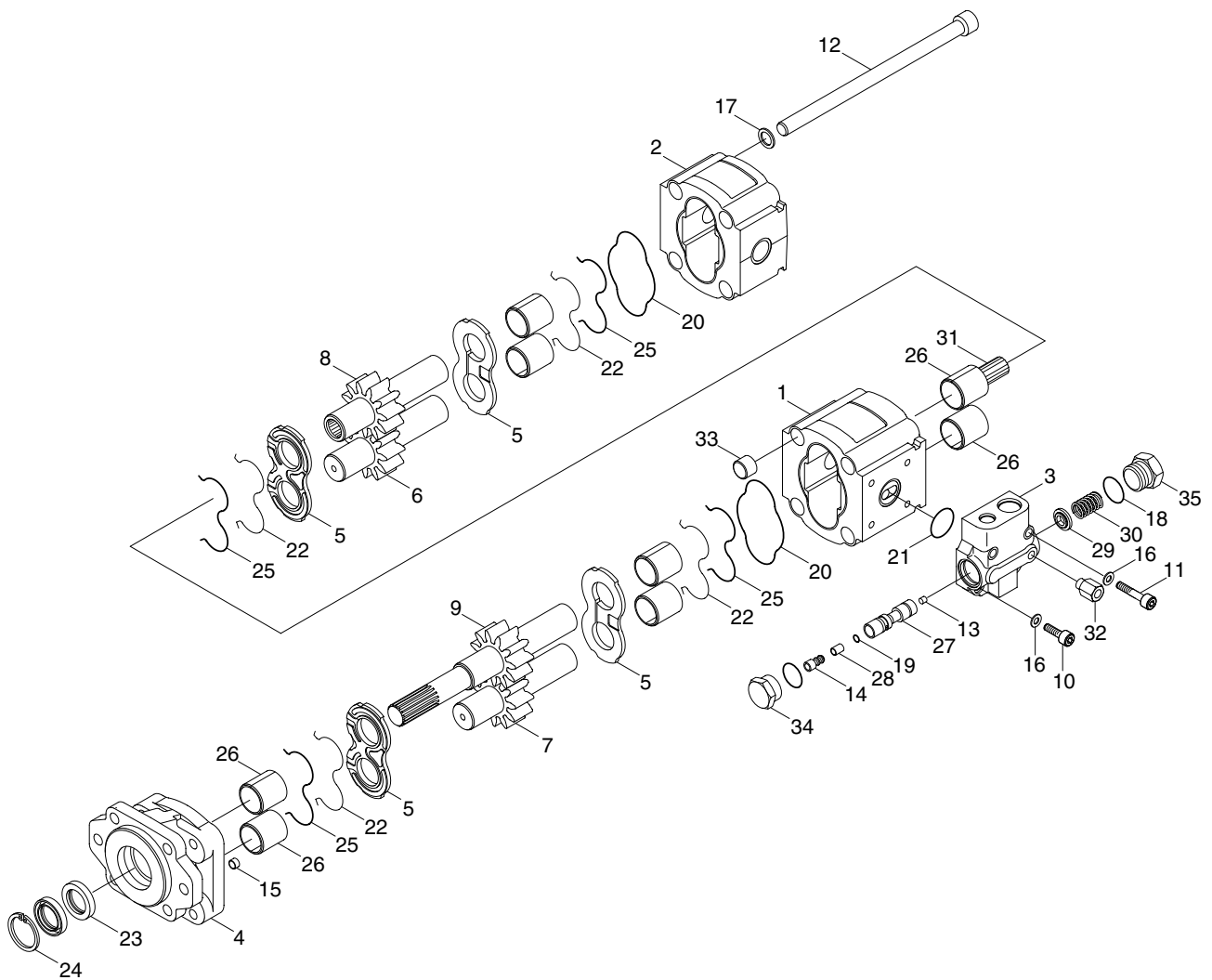

HB100WE21

- | | | | | | |
|----|----------------|----|-------------|----|----------------|
| 1 | Body | 13 | Screw | 25 | Ring |
| 2 | Body | 14 | Screw | 26 | Sleeve bearing |
| 3 | Rear end cover | 15 | Screw | 27 | Spool |
| 4 | Front cover | 16 | Washer | 28 | Filter |
| 5 | Thrust plate | 17 | Washer | 29 | Spring seat |
| 6 | Driven gear | 18 | O-ring seal | 30 | Spring |
| 7 | Driven gear | 19 | O-ring seal | 31 | Hub |
| 8 | Drive shaft | 20 | Ring | 32 | Connection |
| 9 | Drive shaft | 21 | O-ring seal | 33 | Steel bushing |
| 10 | Screw | 22 | Seal | 34 | Plug |
| 11 | Screw | 23 | Shaft seal | | |
| 12 | Screw | 24 | Ring | | |

2) INSTRUCTION

Hydraulic pumps used for the work equipment hydraulic units on construction machinery are pressure loaded type gear pumps. This gear pump could run under 300 kgf/cm^2 (4,350 psi) maximum.

The pressure loaded type gear pump is designed so that the clearance between the gear and the side plate can be automatically adjusted according to the delivery pressure.

Therefore, the oil leakage from the side plate is less than that in the case of the fixed side plate type under a high discharge pressure.

Consequently, no significant reduction of the pump delivery occurs, even when the pump is operated under pressure.

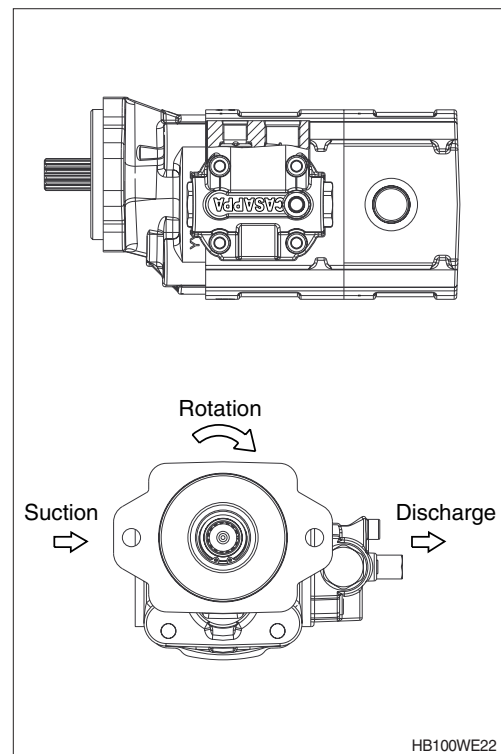

3) PRINCIPLE OF OPERATION

(1) Mechanism for delivering oil

The below drawing shows the operational principle of an external gear pump on which two gears are rotation in mesh.

The oil entering through the suction port is trapped in the space between two gear teeth, and is delivered to the discharge port as the gear rotates.

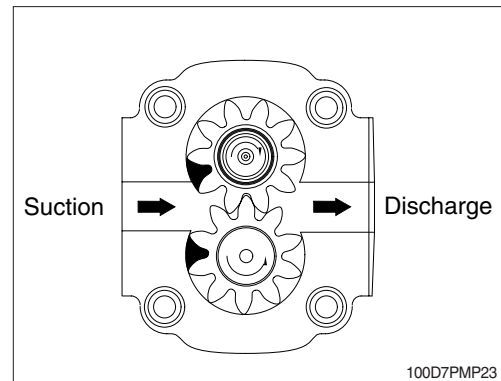

Except for the oil at the above of the gear teeth, is trapped between the gears teeth, the oil trapped between the gear teeth, is prevented from returning to the suction side with the gears in mesh.

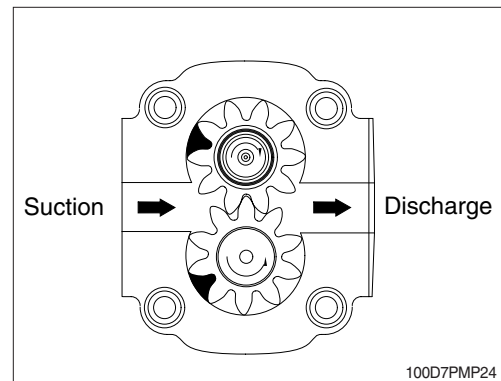

Since the gears are constantly delivering oil, the oil delivered to the discharge port is forced out of the port. The amount of discharge increases with the rotation speed of the gear.

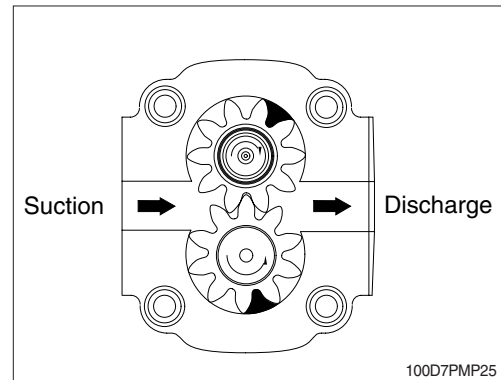

If there is no resistance in the oil passage into which the discharged oil flows, the oil merely flows through the passage, producing no increase in pressure.

If however, the oil passage is blocked with something like a hydraulic cylinder, there will be no other place for the oil to flow, so the oil pressure will rise. But the pressure which rises in this way never to higher, once the hydraulic cylinder piston starts moving because of the oil pressure. As described earlier, the pump produces the oil flow, but not the oil pressure. We can therefore conclude that pressure is a consequence of load. In other words, the pressure depends on a counterpart.

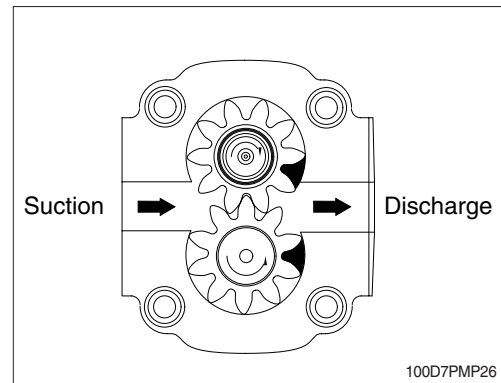

(2) Internal oil leakage

Oil leaks from a place under higher pressure to place under lower pressure, provided that a gap or a clearance exists in between.

In the gear pump, small clearances are provided between the gear and the case and between the gear and the side plate to allow the oil to leak out and to serve as a lubricant so that the pump will be protected from seizure and binding.

The drawing shows how the leaked oil flows in the pump. As such, there is always oil leakage in the pump from the discharge side (under higher pressure) to the suction side. The delivery of the pump is reduced by an amount equal to the pump discharge.

In addition, the delivery of the pump will also decrease as the amount of oil leakage increases because of expanded radial clearance resulting from the wear of pump parts, the lower oil viscosity resulting from increases in the oil temperature, and the initial use of low viscosity oil.

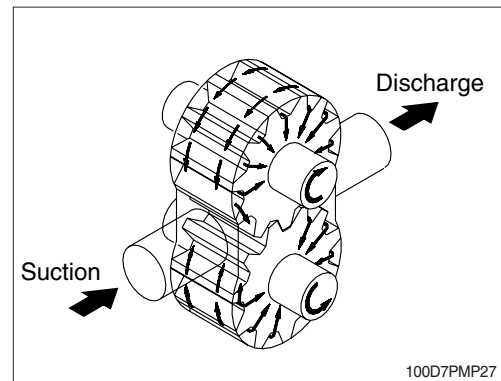

(3) Forces acting on the gear

The gear, whose outer surface is subjected to oil pressure, receives force jointing towards its center. Due to the action of the delivery pressure, the oil pressure is higher on the delivery side of the pump, and due to suction pressure, is lower on the suction side.

In the intermediate section, the pressure will gradually lower as the position moves from the delivery side to the suction side. This phenomenon is shown in the drawing (refer to right figure).

In addition, the gears in mesh will receive interacting forces. These forces pushing the gears toward the suction side are received by the bearings. Since the gears are pressed toward the suction side by these forces, the radial clearance becomes smaller on the suction side in the case. In some pumps, the clearance may become zero, thus allowing the gear teeth and the case to come into light contact.

For this reason, an excessive increase in the delivery pressure must be avoided, since it will produce a large force which will act on the gears, placing an overload on the bearings, and resulting in a shortened service life of the bearing or interference of the gear with the case.

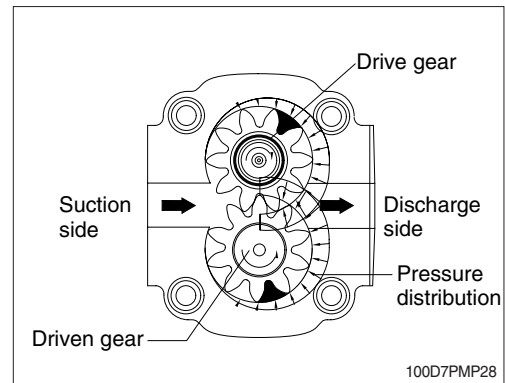

4) GENERAL REFERENCE

(1) Installation

The direction of rotation of single-rotation pumps must be the same as that of the drive shaft. Check that the coupling flange correctly aligns the transmission shaft and the pump shaft. Flexible couplings should be used (never rigid fittings) which will not generate an axial or radial load on the pump shaft.

(2) Starting up

Check that all circuit connections are tight and that entire system is completely clean. Insert the oil in the tank, using a filter. Bleed the circuit assist on filling. Set the pressure relief valves to the lowest possible setting. Turn on the system for a few moments at minimum speed, then bleed the circuit again and check the level of oil in the tank. In the difference between pump temperature and fluid temperature exceeds 10°C, rapidly switch the system on and off to heat it up gradually. Then gradually increase the pressure and speed of rotation until the pre-set operating levels as specified in the catalogue are attained.

(3) Periodical checks-maintenance

Keep the outside surface clean especially in the area of the drive shaft seal. In fact, abrasive power can accelerate wear on the seal and cause leakage. Replace filters regularly to keep the fluid clean. The oil level must be checked and oil replaced periodically depending on the system's operating conditions.

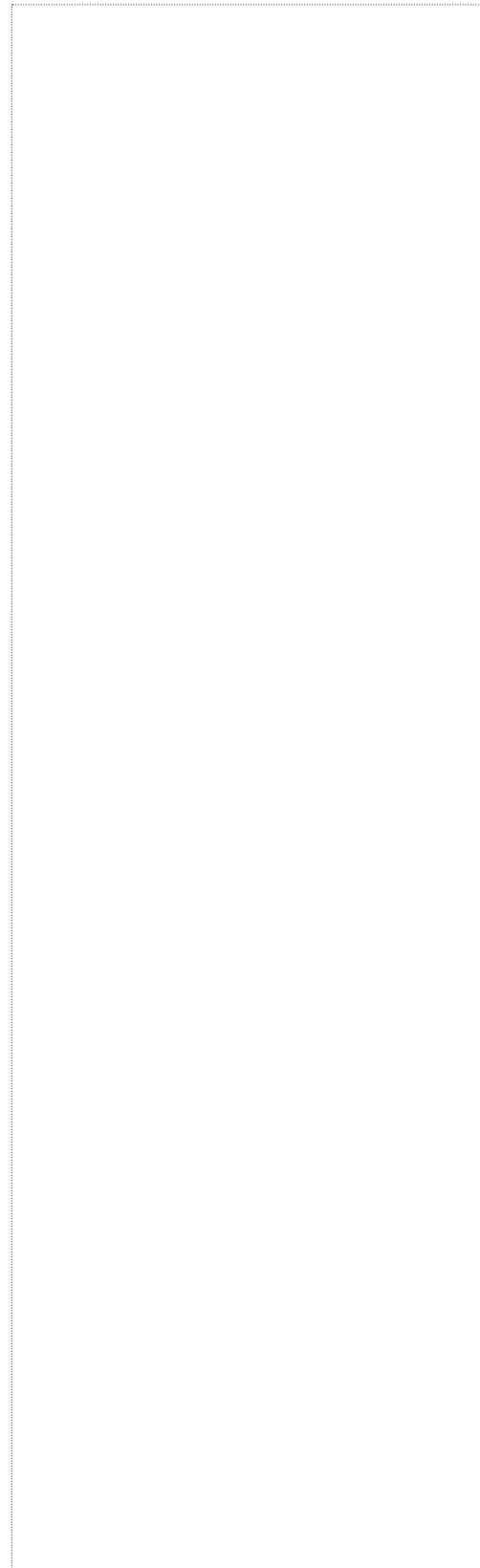

6. LOADER MAIN CONTROL VALVE

1) STRUCTURE (1/2)

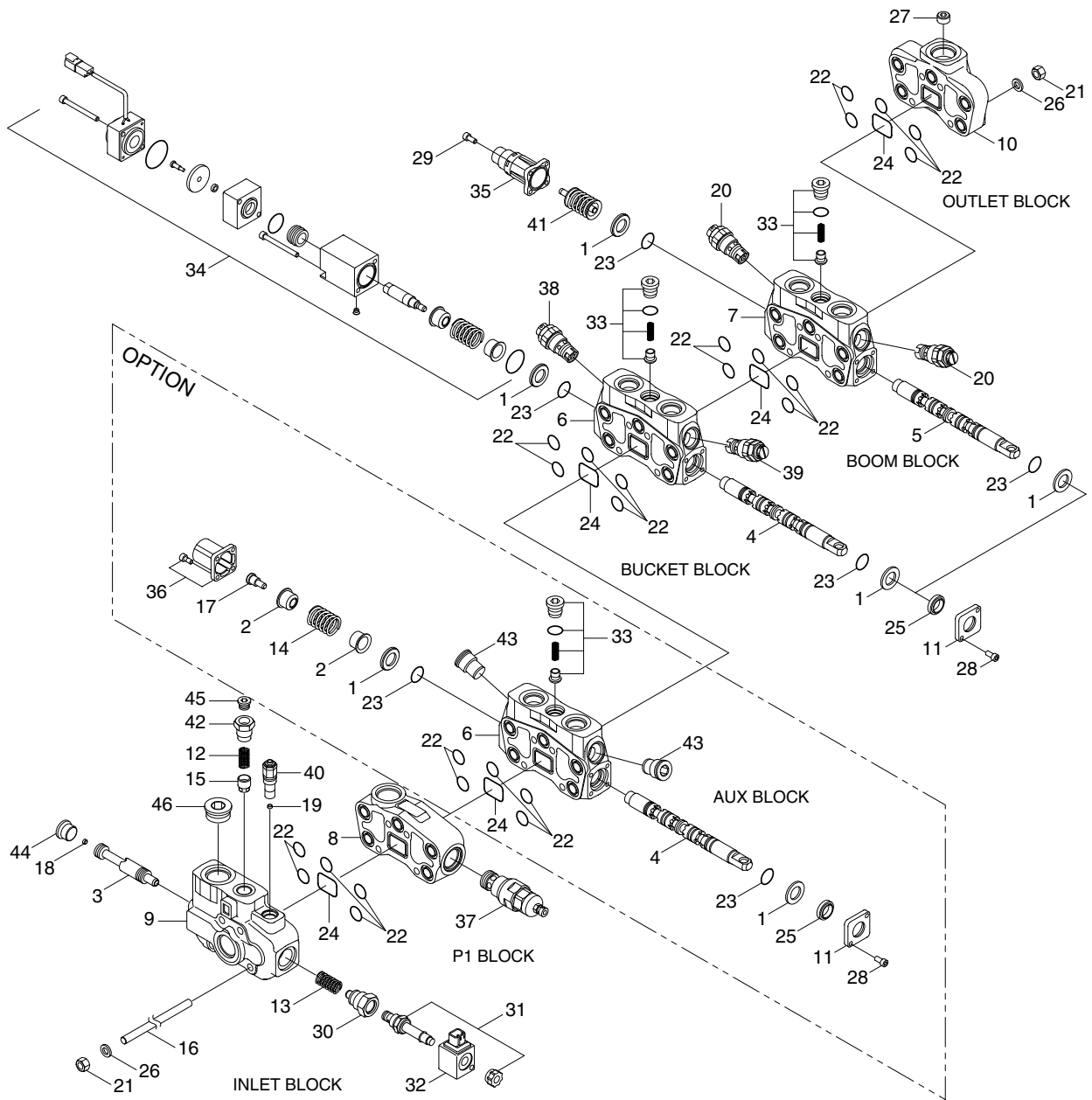

HB100WE36

1	Spacer	13	Spring	25	Seal	37	Relief valve
2	Bushing	14	Spring	26	Spring washer	38	Relief valve
3	Spool	15	Poppet	27	Plug	39	Relief valve
4	Spool	16	Tie rod	28	Screw	40	Relief valve
5	Spool	17	Screw	29	Screw	41	Spring kit
6	Element	18	Dowel	30	Joint	42	Adapter
7	Element	19	Screw	31	Solenoid valve	43	Plug
8	Element	20	Relief valve	32	Body	44	Plug
9	Inlet cover	21	Nut	33	Check valve	45	Plug
10	Outlet cover	22	O-ring	34	Valve kit	46	Plug
11	Flange	23	O-ring	35	Cap		
12	Spring	24	O-ring	36	Cap kit		

STRUCTURE (2/2)

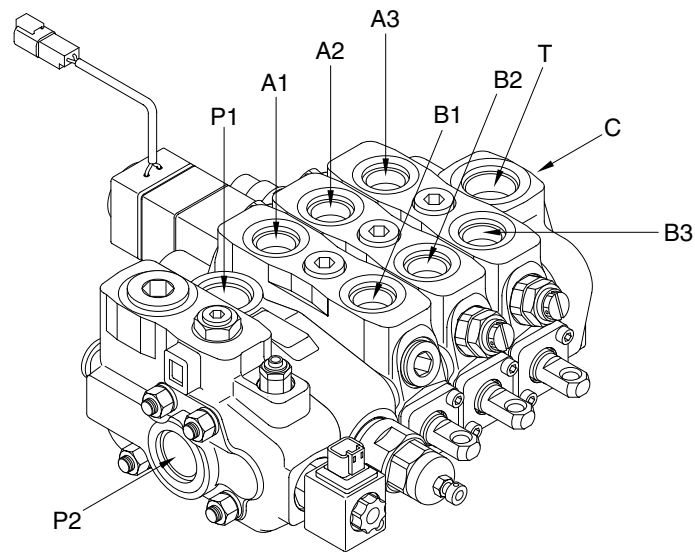

HB100WE41

Port	Port name	Port size
P1	From main pump	1-5/16" UNF-2B
P2	From main pump	1-5/16" UNF-2B
T	To tank (drain)	1-5/16" UNF-2B
C	To MCV (backhoe)	1-5/16" UNF-2B
A1, B1	Auxiliary port	1-1/16" UNF-2B
A2, B2	Bucket cylinder port	1-1/16" UNF-2B
A3, B3	Boom cylinder port	1-1/16" UNF-2B

Item		Specification
Type		2 spool (opt : 3 spool)
Operating method		Manual control
Main relief valve pressure		250 kgf/cm ² (3560 psi)
Unloading relief valve pressure		220 kgf/cm ² (3130 psi)
Overload relief valve pressure	Bucket out	175 kgf/cm ² (2490 psi)
	Bucket in	300 kgf/cm ² (4270 psi)

2) BOOM SECTION OPERATION

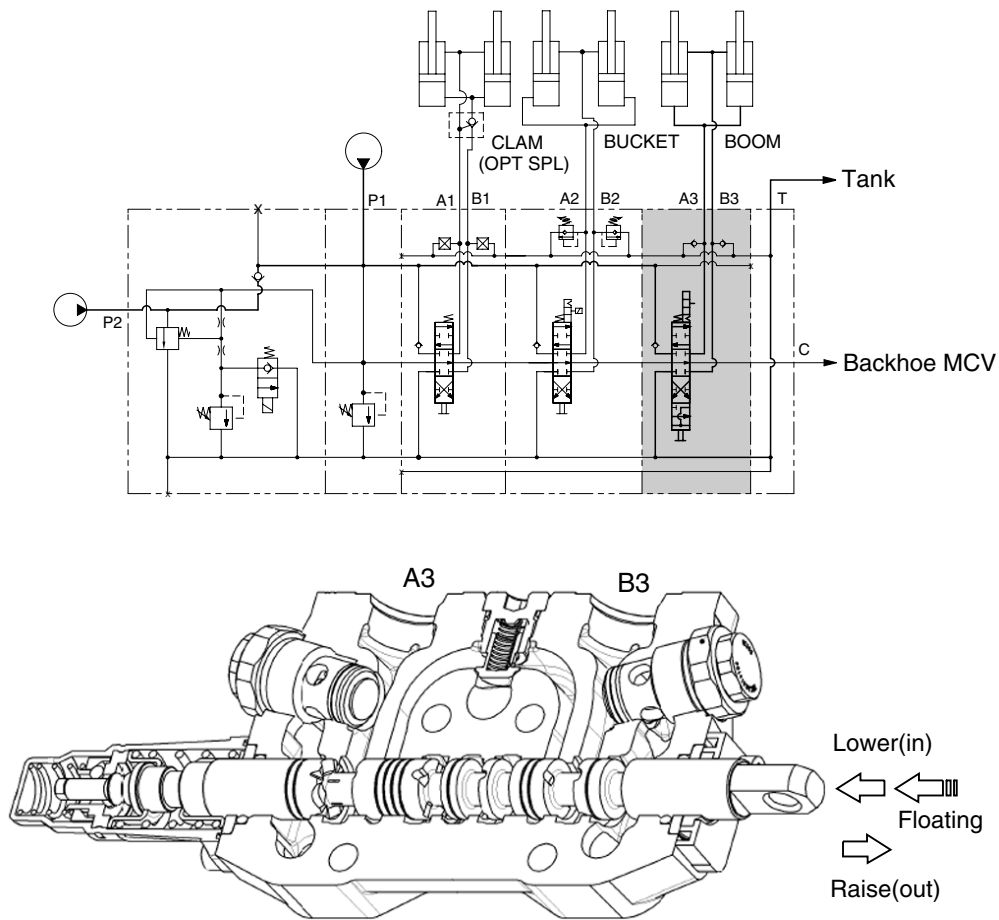

HB100WE42

(1) Spool in neutral

If the control lever is not operated, the oil supplied from the pump ports (P1 & P2) passes through the neutral passage of loader MCV to the backhoe MCV and then returns to the tank.

(2) Boom raise position (when the boom lever is pulled back)

When the boom spool out, the pressured oil supplied from the pumps (P1 & P2) flow through the port (A3) into boom cylinder.

The return oil from cylinder port (B3) flows into the tank via the low pressure passage.

(3) Boom lower position (when the boom lever is pushed)

When the boom spool in, the pressured oil supplied from the pumps (P1 & P2) flow through the port (B3) into boom cylinder.

The return oil from cylinder port (A3) flows into the tank via the low pressure passage.

(4) Boom float position (when the boom lever is in the float position)

When the boom spool in 4th position, the pressured oil supplied from the pumps (P1 & P2) flow through the neutral passage of loader MCV to the backhoe MCV and then returns to the tank.

The return oil from cylinder port (A3 & B3) flows into the tank via the low pressure passage.

3) BUCKET SECTION OPERATION

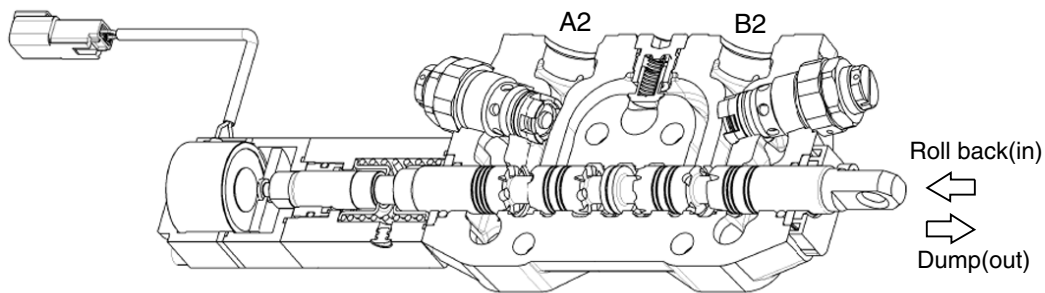
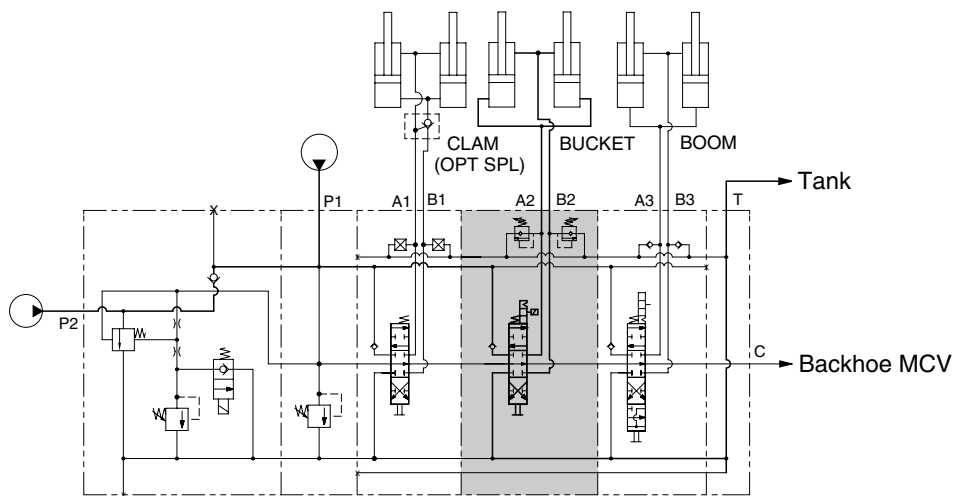

HB100WE43

(1) Spool in neutral

If the control lever is not operated, the oil supplied from the pump ports (P1 & P2) passes through the neutral passage of loader MCV to the backhoe MCV and then returns to the tank.

(2) Bucket roll back position (when moving the control lever to your left)

When the bucket spool in, the pressured oil supplied from the pumps (P1 & P2) flow through the port (B2) into bucket cylinder.

The return oil from cylinder port (A2) flows into the tank via the low pressure passage.

(3) Bucket dump position (when moving the control lever to your right)

When the bucket spool out, the pressured oil supplied from the pumps (P1 & P2) flow through the port (A2) into bucket cylinder.

The return oil from cylinder port (B2) flows into the tank via the low pressure passage.

4) INLET SECTION WITH UNLOAD OPERATION

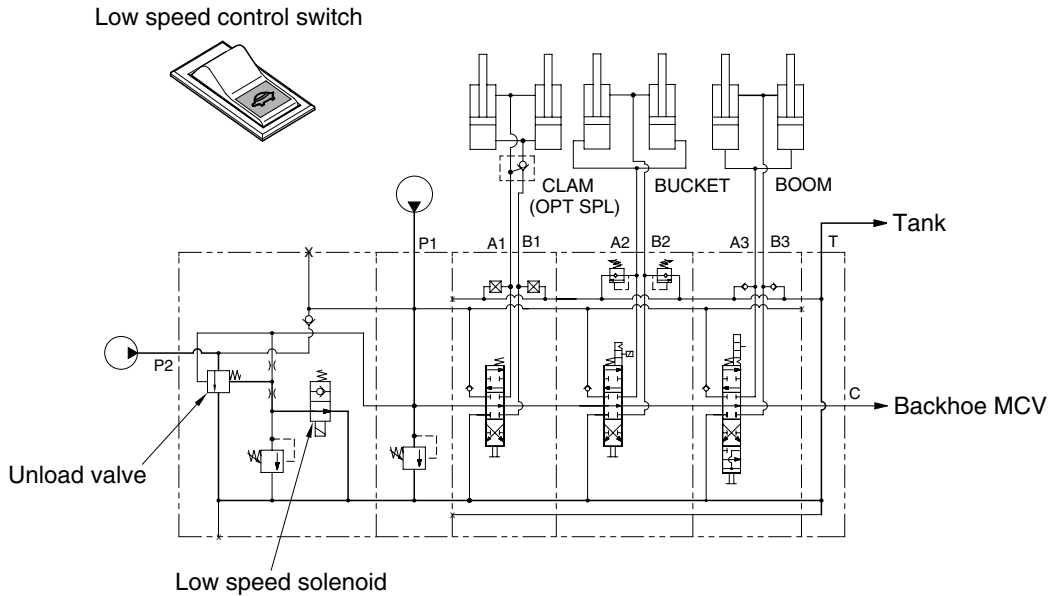

HB100WE40

(1) Switch in neutral

If the low speed control switch at the side console is not operated, the oil supplied from the pump ports (P1 & P2) is joined and passes through the neutral passage of loader MCV to the backhoe MCV and then returns to the tank.

(2) Unloading position (when pushed the switch)

If the switch at the side console is operated, the oil supplied from the pump port (P1) passes through the neutral passage of loader MCV to work port.

On the other hand, the oil supplied from the pump port (P2) passes through the unload valve in inlet section returns to the tank.

5) AUXILIARY SECTION OPERATION (CLAM, OPTION)

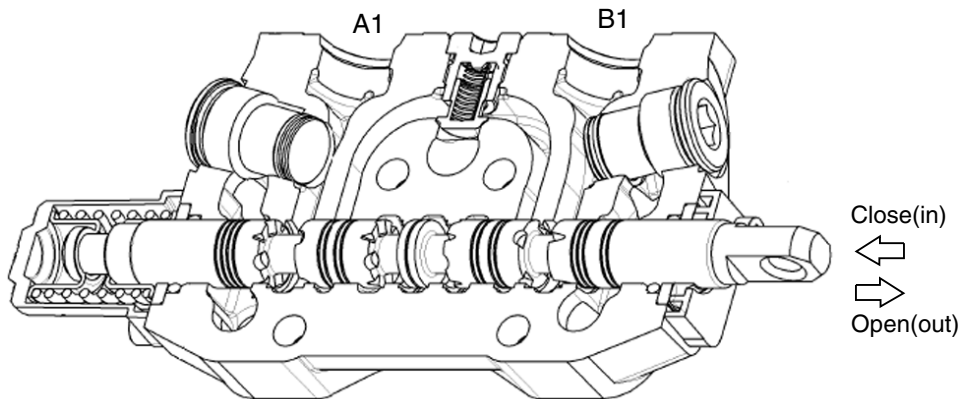
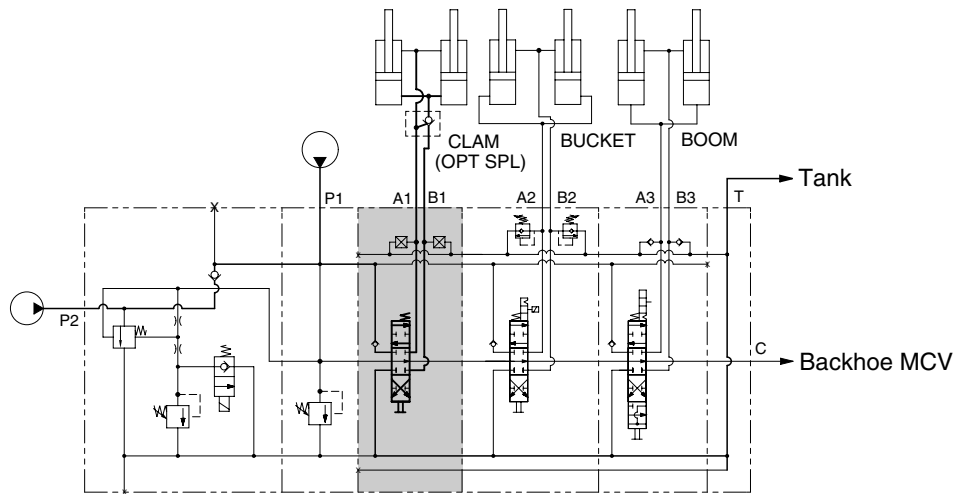

HB100WE45

(1) Spool in neutral

If the control lever is not operated, the oil supplied from the pump ports (P1 & P2) passes through the neutral passage of loader MCV to the backhoe MCV and then returns to the tank.

(2) Clam open position (when the clam lever is pushed)

When the clam spool out, the pressured oil supplied from the pumps (P1 & P2) flow through the port (A1) into clam cylinder.

The return oil from cylinder port (B1) flows into the tank via the low pressure passage.

(3) Clam close position (when the clam lever is pulled back)

When the clam spool in, the pressured oil supplied from the pumps (P1 & P2) flow through the cylinder port (B1) into clam cylinder.

The return oil from cylinder port (A1) flows into the tank via the low pressure passage.

7. BACKHOE MAIN CONTROL VALVE

1) STRUCTURE (1/4)

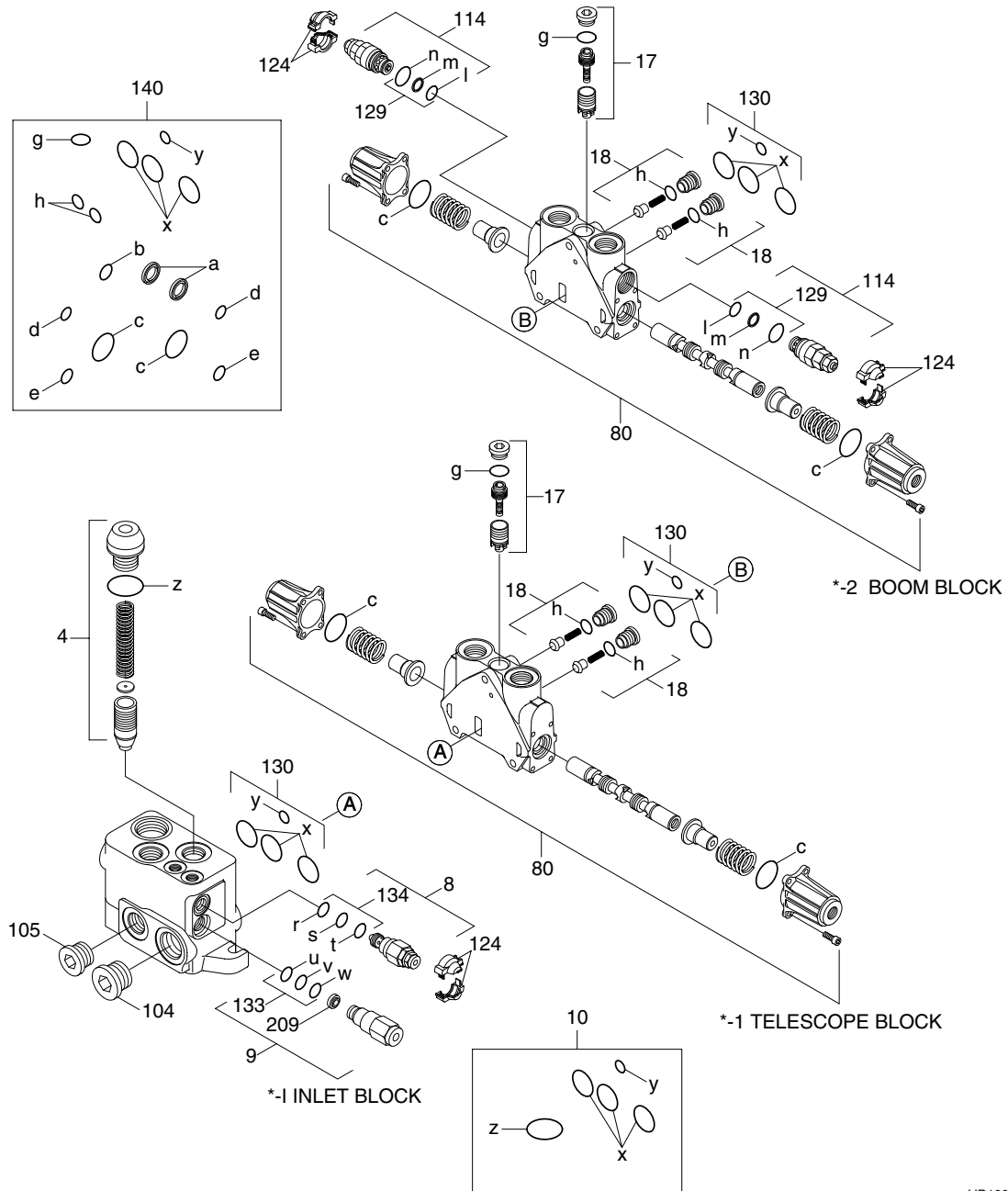

HB100WE33

4	Regulation kit	80	Hydraulic operation	130	Seal kit
8	Relief valve	104	Plug	133	Seal kit
9	Flow regulator	105	Plug	134	Seal kit
10	Seal kit	114	Relief valve	140	Seal kit
17	Pressure compensator kit	124	Cover	209	Filter
18	Check valve kit	129	Seal kit		

STRUCTURE (2/4)

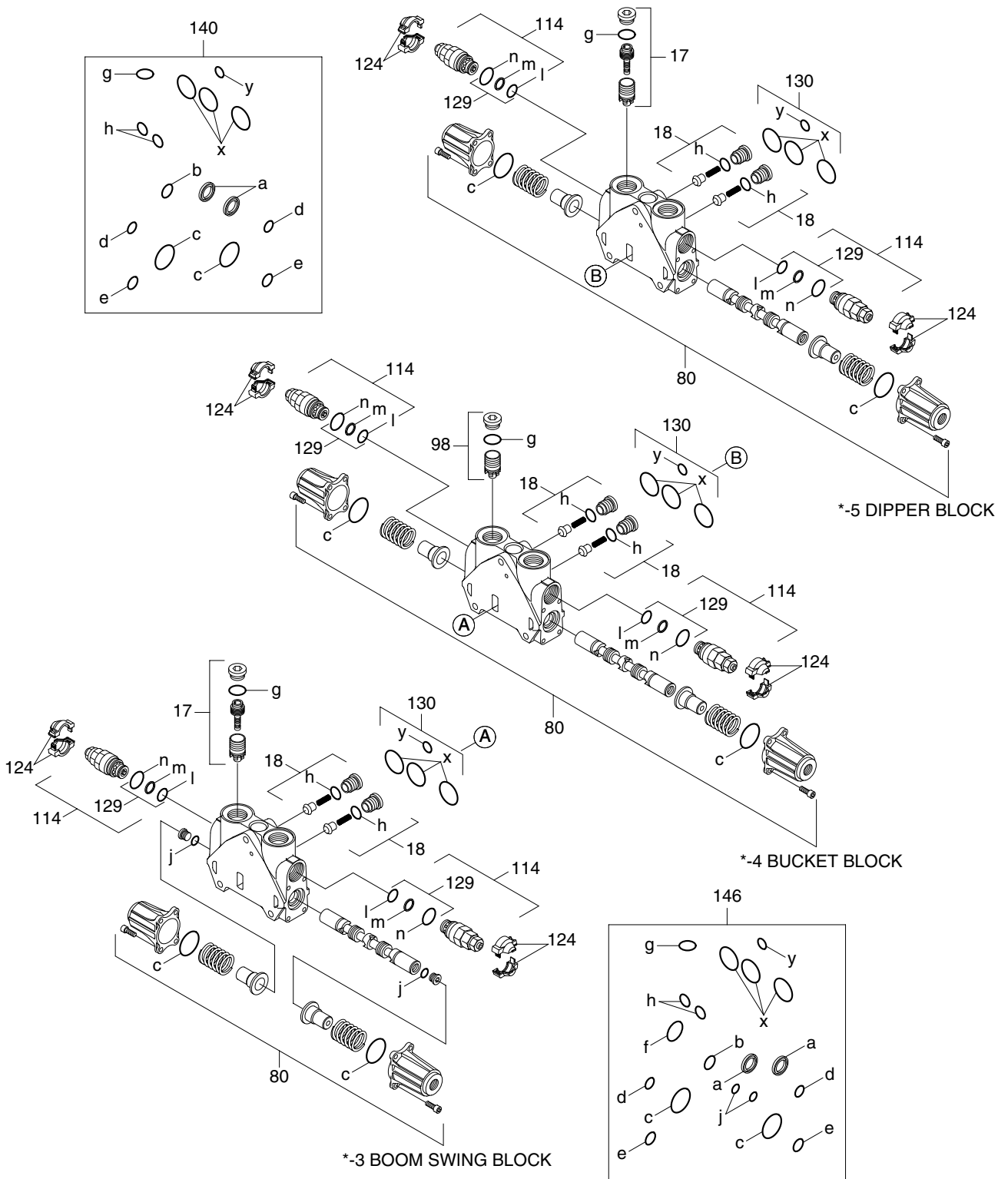

HB100WE34

- | | | | | | |
|----|--------------------------|-----|--------------|-----|----------|
| 17 | Pressure compensator kit | 114 | Relief valve | 140 | Seal kit |
| 18 | Check valve kit | 124 | Cover | 146 | Seal kit |
| 80 | Hydraulic operation | 129 | Seal kit | | |
| 98 | Pressure compensator kit | 130 | Seal kit | | |

STRUCTURE (3/4)

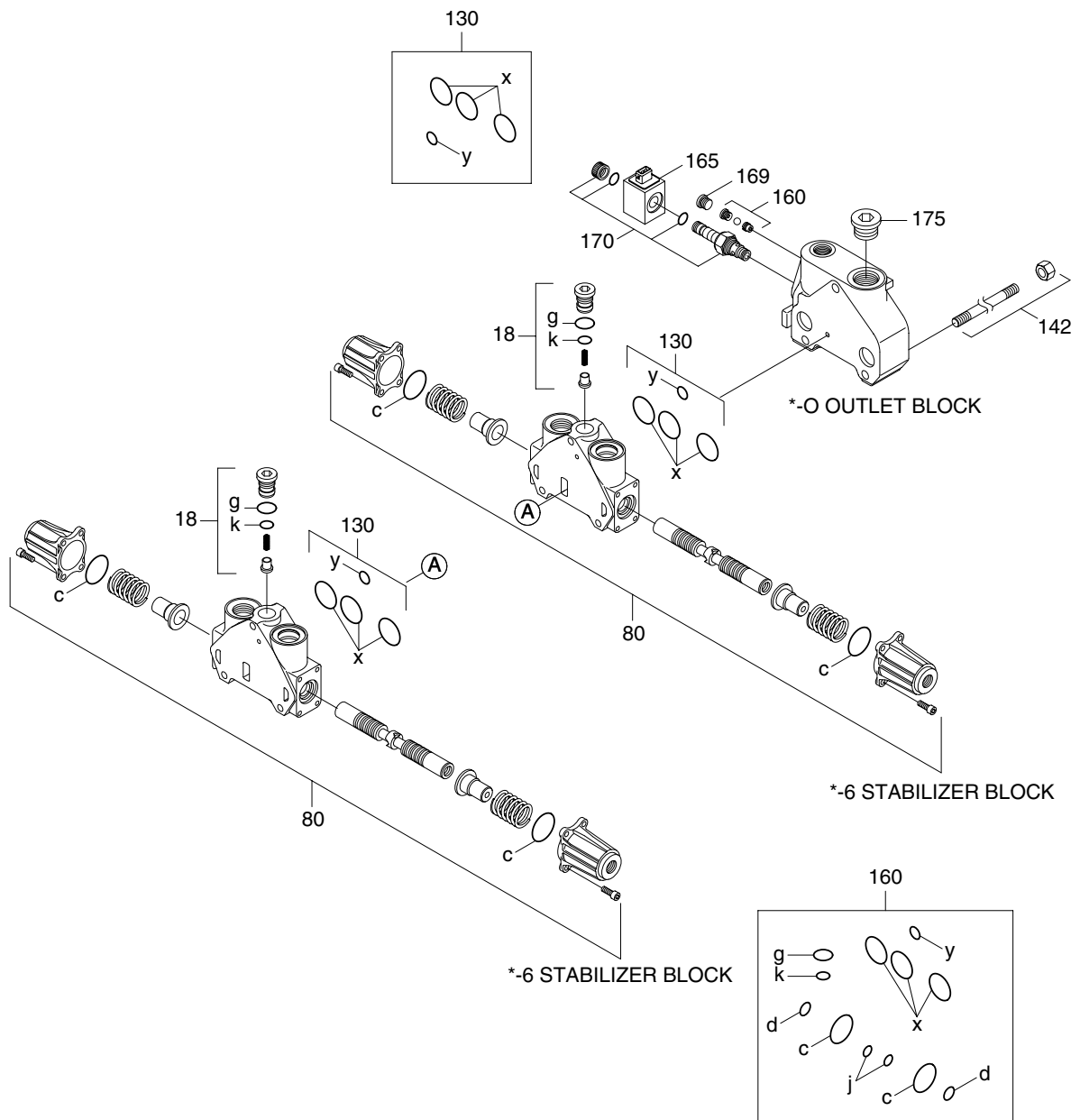

HB100WE35

- | | | | | | |
|-----|---------------------|-----|------------|-----|------------------|
| 18 | Check valve | 142 | Stud & Nut | 169 | Plug |
| 80 | Hydraulic operation | 160 | Seal kit | 170 | 2 ways valve kit |
| 130 | Seal kit | 165 | Solenoid | 175 | Plug |

STRUCTURE (4/4)

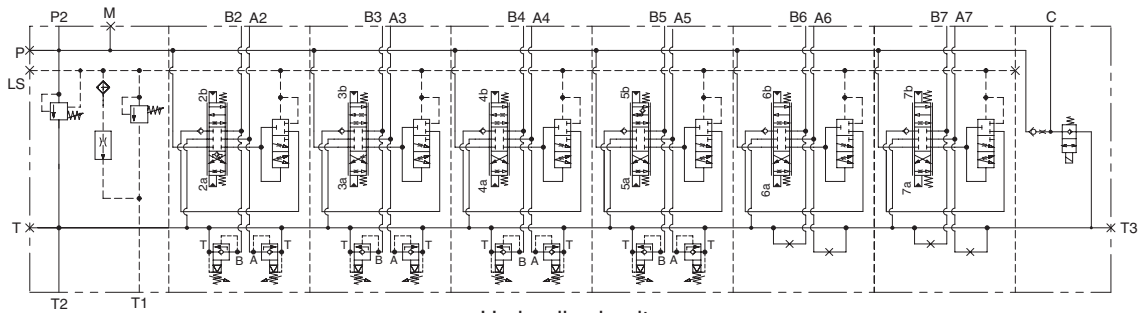
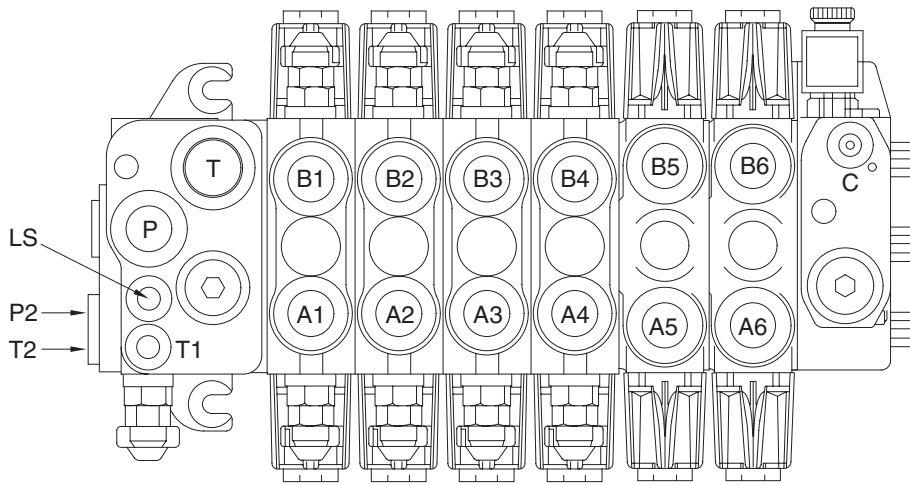

Hydraulic circuit

HB100WE46

Port	Port name	Port size
P	From main pump	1-1/16" UNF-2B
T2	To tank (return)	1-5/16" UNF-2B
T1	To tank (drain)	9/16" UNF-2B
A2, B2	Boom cylinder port	1-1/16" UNF-2B
A3, B3	Boom swing cylinder port	1-1/16" UNF-2B
A4, B4	Bucket cylinder port	1-1/16" UNF-2B
A5, B5	Dipper cylinder port	1-1/16" UNF-2B
A6, B6	Stabilizer cylinder port-RH	1-1/16" UNF-2B
A7, B7	Stabilizer cylinder port-LH	1-1/16" UNF-2B
C	Hydro-clamp port	1-1/16" UNF-2B

Item		Specification
Type		6 spool (opt : 7 spool)
Operating method		Hydraulic pilot control
Main relief valve pressure		250 kgf/cm ² (3560 psi)
Overload relief valve pressure	Boom up	300 kgf/cm ² (4270 psi)
	Boom down	300 kgf/cm ² (3980 psi)
	Swing LH, RH	240 kgf/cm ² (3410 psi)
	Bucket in	300 kgf/cm ² (4270 psi)
	Bucket out	300 kgf/cm ² (4270 psi)
	Dipper in	300 kgf/cm ² (4270 psi)
	Dipper out	300 kgf/cm ² (4270 psi)

2) BOOM SECTION OPERATION

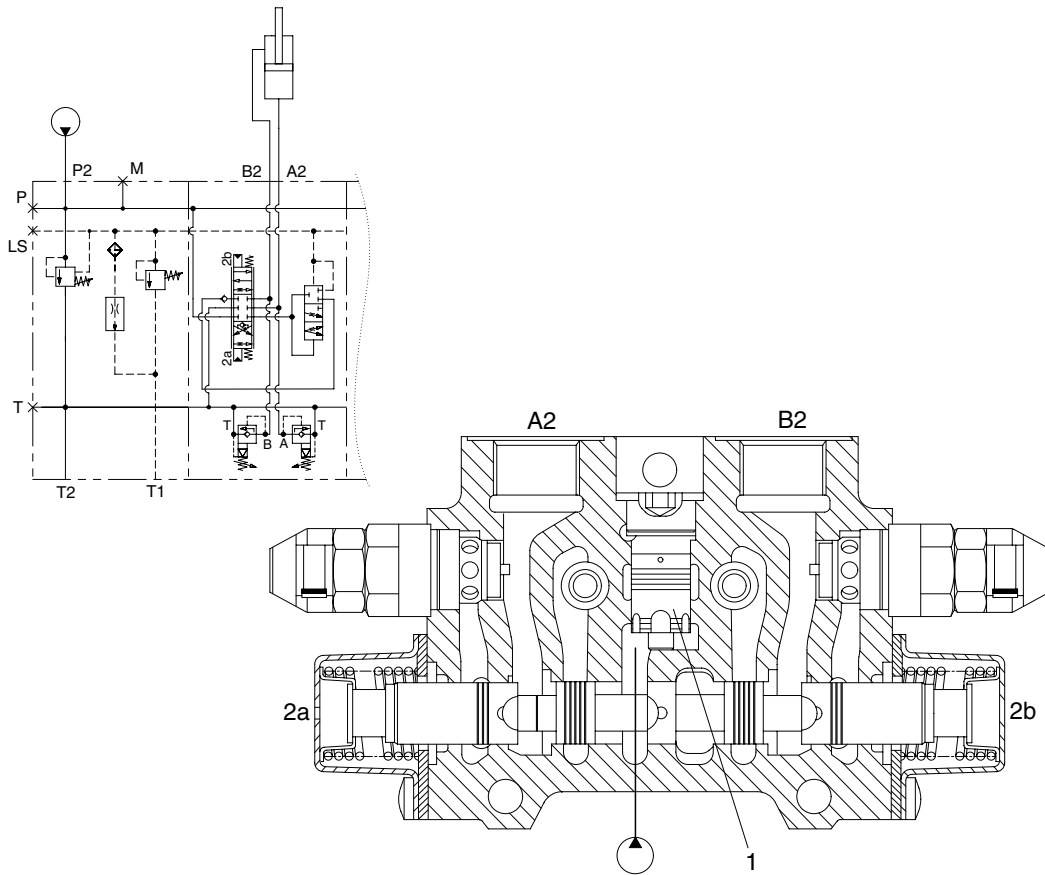

HB100WE47

(1) Spool in neutral

If the backhoe RCV is not operated, the oil supplied from the pump port (P2) passes through the neutral passage to the low pressure passage at the outlet section, and then returns to the tank port (T2).

(2) Boom raise position (when the RCV lever is pulled back)

When the pilot pressure from remote control valve (RCV) is supplied to the pilot port (2a), the spool moves to the left and the neutral passage is closed.

The oil supplied from the pump flow through pressure compensator (1) into boom cylinder port (A2).

The pump pressure reaches proportionally the load of cylinder and fine control finished by shut off of the neutral passage.

The return oil from cylinder port (B2) flows into the tank via the low pressure passage.

(3) Boom lower position (when the RCV lever is pushed forward)

When the pilot pressure from remote control valve (RCV) is supplied to the pilot port (2b), the spool moves to the right and the neutral passage is closed.

The oil supplied from the pump flow through pressure compensator (1) into boom cylinder port (B2). The pump pressure reaches proportionally the load of cylinder and fine control finished by shut off of the neutral passage.

The return oil from cylinder port (A2) flows into the tank via the low pressure passage.

3) BOOM SWING SECTION OPERATION

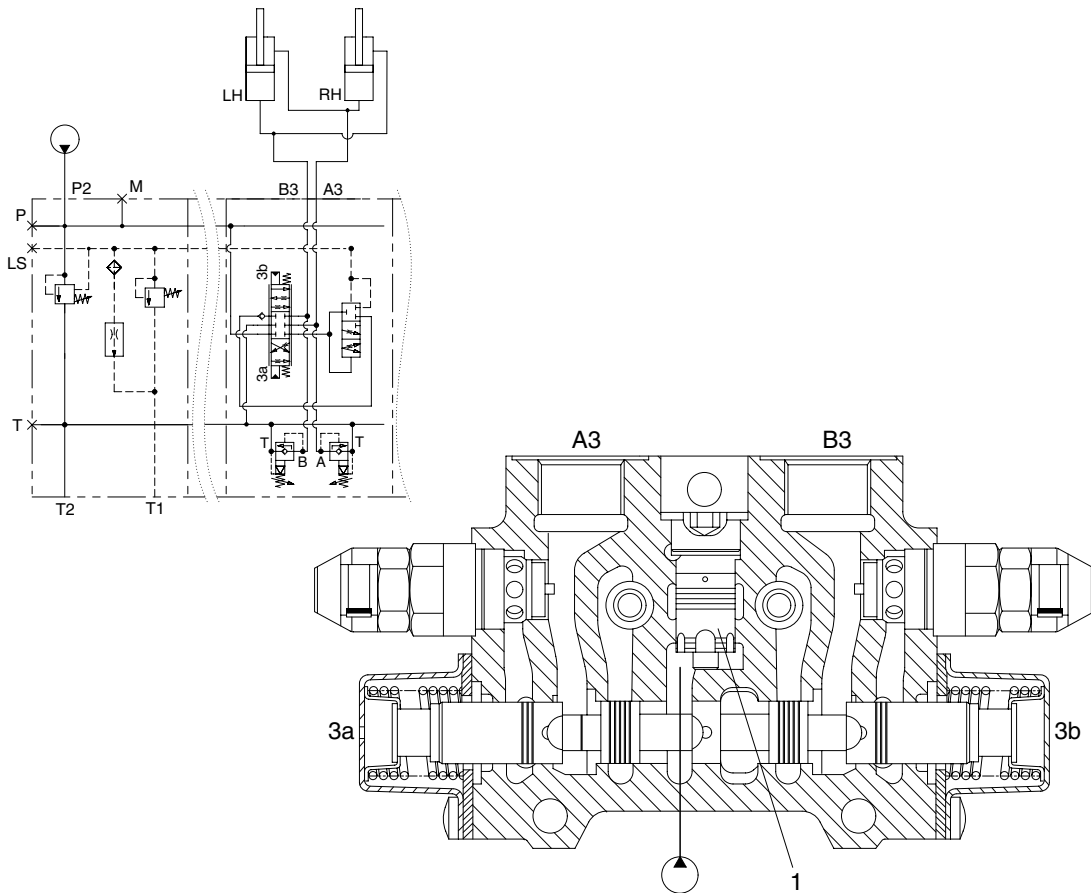

HB100WE120

(1) Spool in neutral

If the backhoe RCV is not operated, the oil supplied from the pump port (P2) passes through the neutral passage to the low pressure passage at the outlet section, and then returns to the tank port (T2).

(2) Swing left position (when moving the RCV lever to your left)

When the pilot pressure from remote control valve (RCV) is supplied to the pilot port (3a), the spool moves to the right and the neutral passage is closed.

the oil supplied from the pump flow through pressure compensator (1) into swing cylinders port (A3). The pump pressure reaches proportionally the load of cylinder and fine control finished by shut off of the neutral passage.

The return oil from cylinder port (B3) flows into the tank via the low pressure passage.

(3) Swing right position (when moving the RCV lever to your right)

When the pilot pressure from remote control valve (RCV) is supplied to the pilot port (3b), the spool moves to the left and the neutral passage is closed.

The oil supplied from the pump flow through pressure compensator (1) into swing cylinders port (B3). The pump pressure reaches proportionally the load of cylinder and fine control finished by shut off of the neutral passage.

The return oil from cylinder port (A3) flows into the tank via the low pressure passage.

4) BUCKET SECTION OPERATION

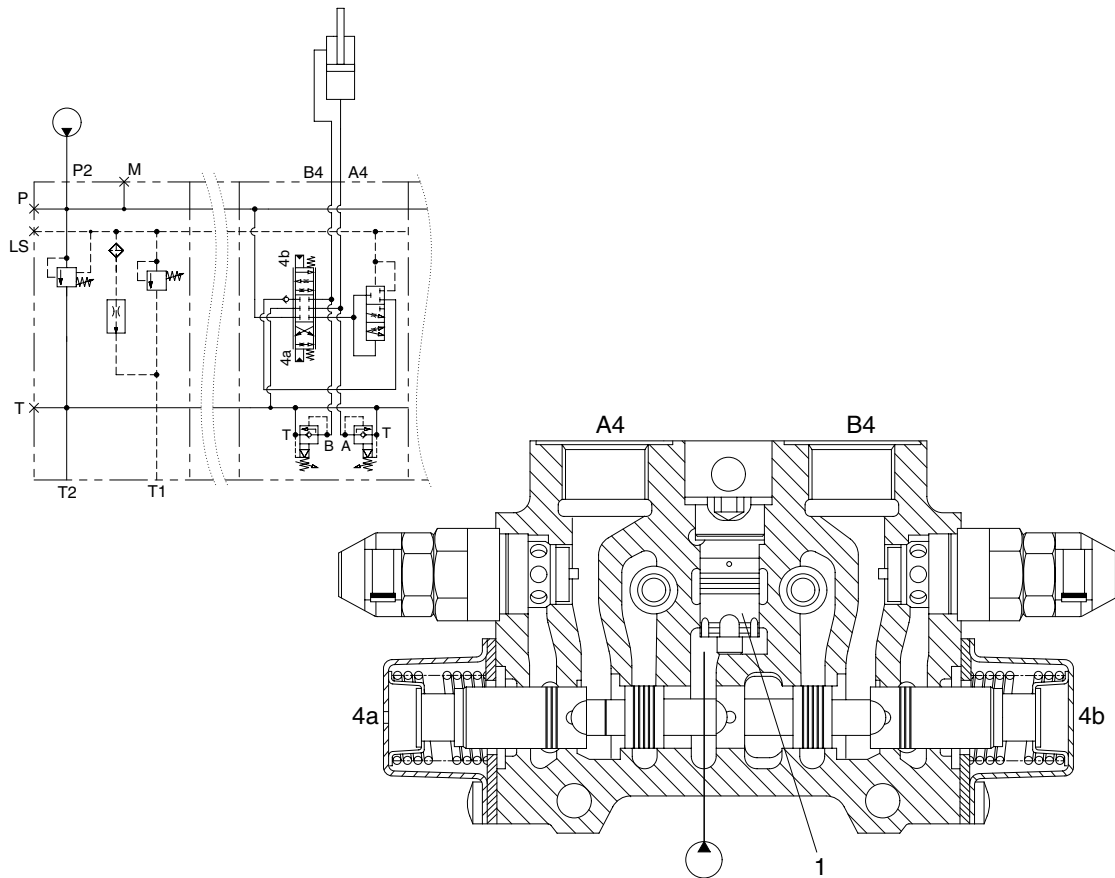

HB100WE121

(1) Spool in neutral

If the backhoe RCV is not operated, the oil supplied from the pump port (P2) passes through the neutral passage to the low pressure passage at the outlet section, and then returns to the tank port (T2).

(2) Bucket crowd position (when the RCV lever is pushed forward)

When the pilot pressure from remote control valve (RCV) is supplied to the pilot port (4a), the spool moves to the right and the neutral passage is closed.

The oil supplied from the pump flow through pressure compensator (1) into bucket cylinder port (A4). The pump pressure reaches proportionally the load of cylinder and fine control finished by shut off of the neutral passage.

The return oil from cylinder port (B4) flows into the tank via the low pressure passage.

(3) Bucket dump position (when the RCV lever is pulled back)

When the pilot pressure from remote control valve (RCV) is supplied to the pilot port (4b), the spool moves to the left and the neutral passage is closed.

The oil supplied from the pump flow through pressure compensator (1) into bucket cylinder port (B4). The pump pressure reaches proportionally the load of cylinder and fine control finished by shut off of the neutral passage.

The return oil from cylinder port (A4) flows into the tank via the low pressure passage.

5) DIPPER SECTION OPERATION

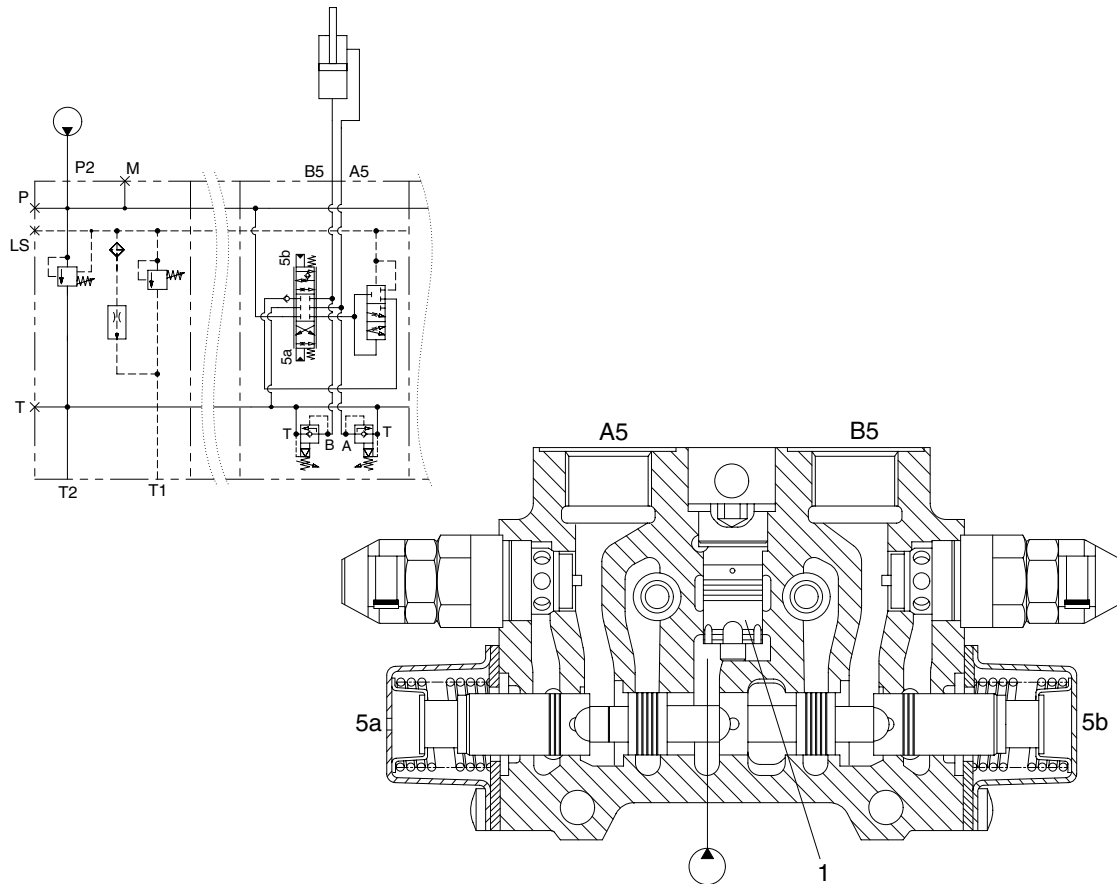

HB100WE122

(1) Spool in neutral

If the backhoe RCV is not operated, the oil supplied from the pump port (P2) passes through the neutral passage to the low pressure passage at the outlet section, and then returns to the tank port (T2).

(2) Dipper in position (when moving the RCV lever to your left)

When the pilot pressure from remote control valve (RCV) is supplied to the pilot port (5a), the spool moves to the right and the neutral passage is closed.

The oil supplied from the pump flow through pressure compensator (1) into dipper cylinder port (A5). The pump pressure reaches proportionally the load of cylinder and fine control finished by shut off of the neutral passage.

The return oil from cylinder port (B5) flows into the tank via the low pressure passage.

(3) Dipper out position (when moving the RCV lever to your right)

When the pilot pressure from remote control valve (RCV) is supplied to the pilot port (5b), the spool moves to the left and the neutral passage is closed.

The oil supplied from the pump flow through pressure compensator (1) into boom cylinder port (B5). The pump pressure reaches proportionally the load of cylinder and fine control finished by shut off of the neutral passage.

The return oil from cylinder port (A5) flows into the tank via the low pressure passage.

6) STABILIZER SECTION OPERATION

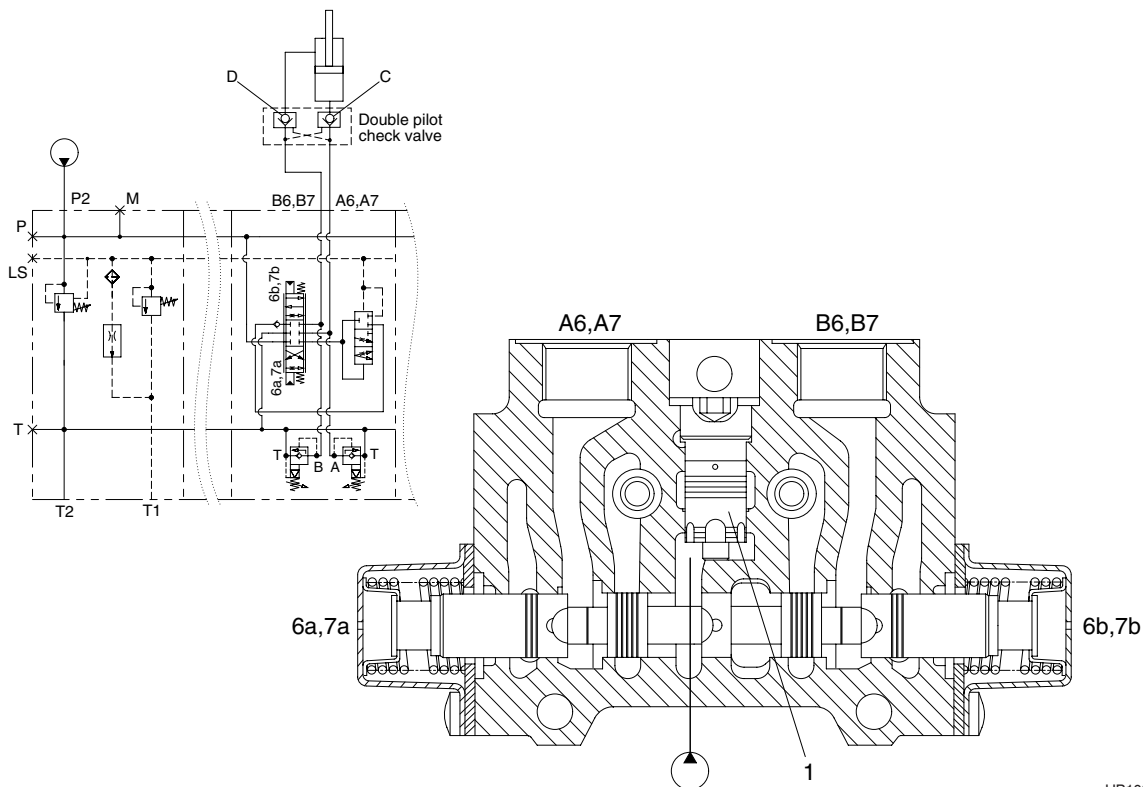

HB100WE123

※ Double pilot check valve

This machine has two stabilizers, each operated by its own control valve and cylinder.

The check valve assembly provides protection in the event of a hose burst in both the stabilizer raise and lower circuit. The operation for both stabilizers is identical.

The following describes the operation of the check valve assembly for one stabilizer.

(1) Spool in neutral

If the backhoe remote control valve (RCV) is not operated, the oil supplied from the pump port (P) passes through the neutral passage to the low pressure passage at the outlet section, and then returns to the tank port (T2).

(2) Stabilizer lower position (when the RCV lever is pushed forward)

When the pilot pressure from remote control valve (RCV) is supplied to the pilot port (6a or 7a), the spool moves to the right and the neutral passage is closed.

The oil supplied from the pump flow through pressure compensator (1) into the double pilot check valve assembly.

The ball C is forced off its seat. Oil also flow across a pilot drilling and forces ball D off its seat.

Oil now flows to the head side of the stabilizer cylinder. Oil flows from the rod side past ball D and the return oil from cylinder port(B6 or B7) flows into the tank via the low pressure passage.

(3) Stabilizer raise position (when the RCV lever is pulled back)

When the pilot pressure from remote control valve (RCV) is supplied to the pilot port (6b or 7b), the spool moves to the right and the neutral passage is closed.

The oil supplied from the pump flow through pressure compensator (1) into the double pilot check valve assembly.

The ball D is forced off its seat. Oil also flow across a pilot drilling and forces ball C off its seat.

Oil now flows to the rod side of the stabilizer cylinder. Oil flows from the head side past ball C and the return oil from cylinder port (A6 or A7) flows into the tank via the low pressure passage.

7) CLAMP SECTION OPERATION

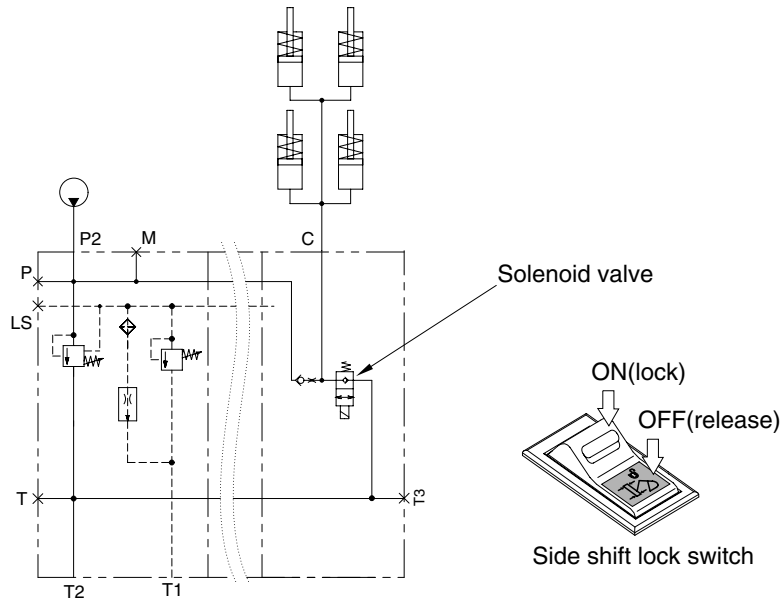

HB100WE124

- ※ When the backhoe is being used for excavating duties, the carriage assembly must be **clamped** to the side shift rearframe.

The clamp control valve assembly is positioned in the outlet end of backhoe control valve block and is connected directly to the pressure passage.

The valve operates in conjunction with solenoid valve housed in the side of the MCV block.

(1) Clamps pressurized position

When the side shift lock switch is in the ON position (not pressed), the solenoid valve is de-energized. The solenoid valve in this de-energized state blocks the exhaust path from the pressure passage to the drain port (tank).

When an backhoe service is operated, pressure is generated in pressure passage, this pressurized oil enters the clamp cylinder through clamp valve port (C).

(2) Clamps released position - Not precision control machines

When the Hydra-clamp switch is in the OFF position (pressed down), the solenoid valve is energized. The solenoid valve in this energized state now allows a connection to be made the pressure passage to the drain port (tank).

Oil from the clamp cylinder is vented through the clamp valve to the drain port (tank).

8. BACKHOE RCV LEVER

1) STRUCTURE

The casing has the oil inlet port P (primary pressure) and the oil outlet port T (tank). In addition the secondary pressure is taken out through ports 1, 2, 3 and 4 provided at the bottom face.

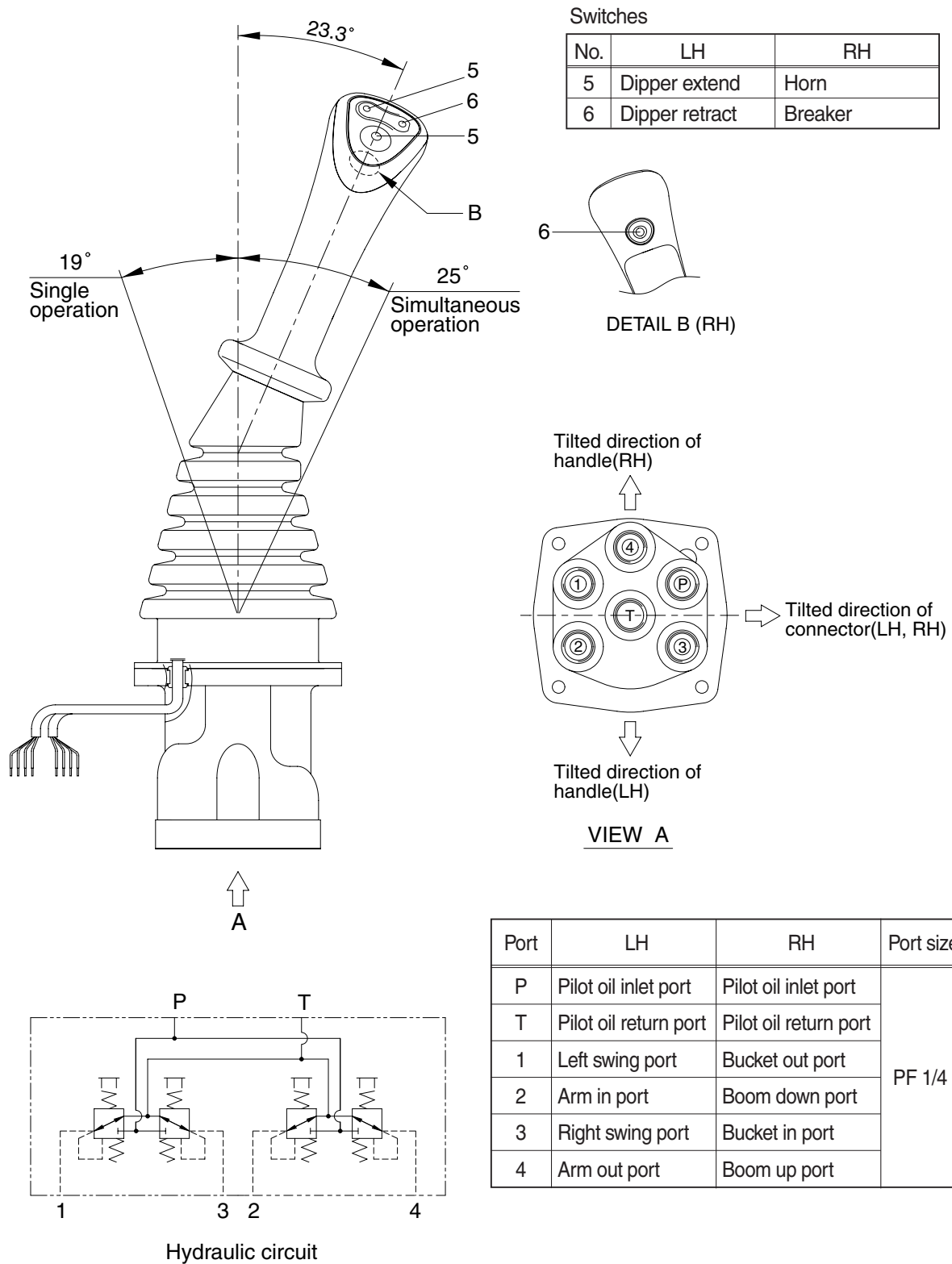

HB100WE144

CROSS SECTION

The construction of the pilot valve is shown in the attached cross section drawing. The casing has vertical holes in which reducing valves are assembled.

The pressure reducing section is composed of the spool (4), spring (6) for setting secondary pressure, return spring (10), stopper (8), spring seat (7, 13) and shim (5). The spring for setting the secondary pressure has been generally so preset that the secondary pressure is 5 to 20.5 kgf/cm² (depending on the type). The spool is pushed against the push rod (9, 11) by the return spring.

When the push rod is pushed down by tilting the handle, the spring seat comes down simultaneously and changes setting of the secondary pressure spring.

CROSS SECTION

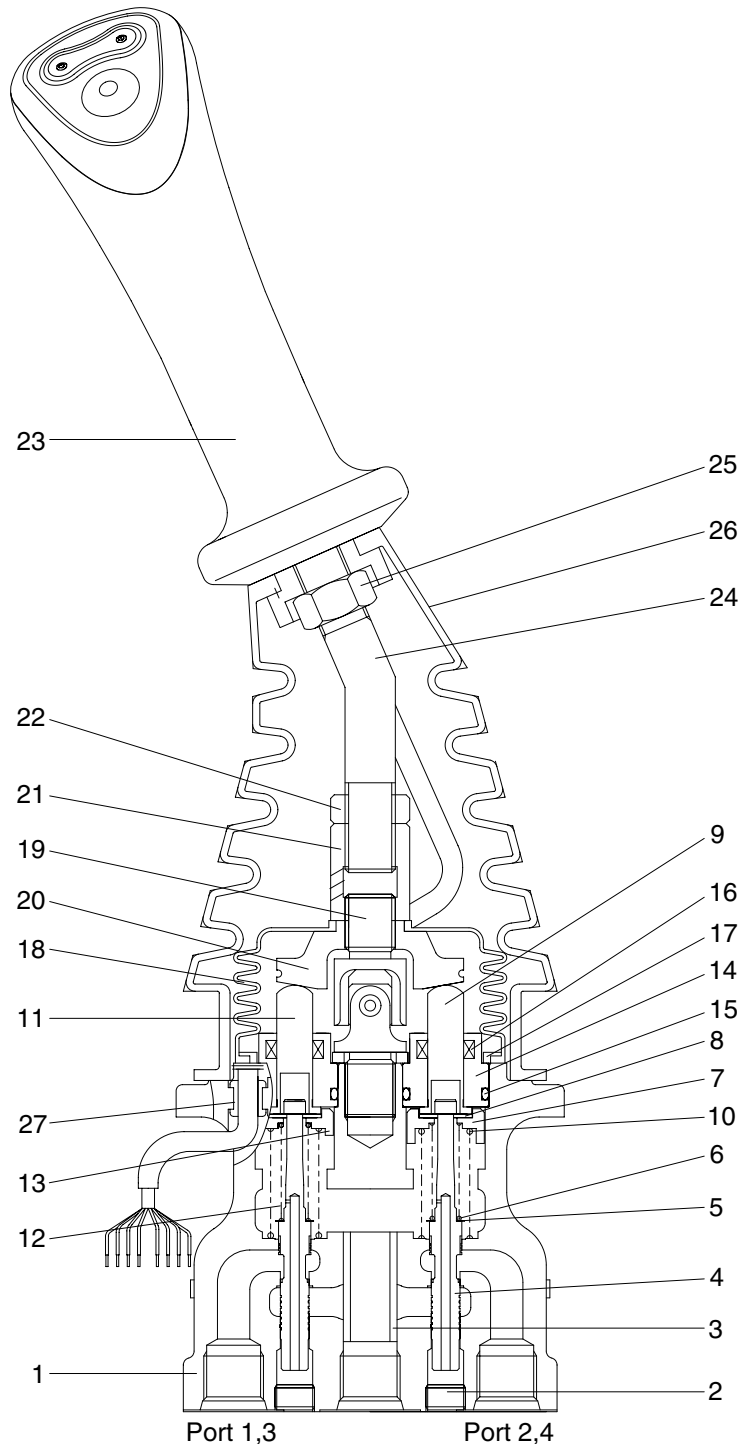

HB100WE145

- | | | | |
|---------------|----------------|-------------------|--------------------|
| 1 Case | 8 Stopper | 15 O-ring | 22 Lock nut |
| 2 Plug | 9 Push rod | 16 Rod seal | 23 Handle assembly |
| 3 Bushing | 10 Spring | 17 Plate | 24 Handle bar |
| 4 Spool | 11 Push rod | 18 Boot | 25 Nut |
| 5 Shim | 12 Spring | 19 Joint assembly | 26 Boot |
| 6 Spring | 13 Spring seat | 20 Swash plate | 27 Bushing |
| 7 Spring seat | 14 Plug | 21 Adjusting nut | |

2) FUNCTIONS

(1) Fundamental functions

The pilot valve is a valve that controls the spool stroke, direction, etc of a main control valve. This function is carried out by providing the spring at one end of the main control valve spool and applying the output pressure (secondary pressure) of the pilot valve to the other end.

For this function to be carried out satisfactorily, the pilot valve is composed of the following elements.

- ① Inlet port (P) where oil is supplied from hydraulic pump.
- ② Output ports (1, 2, 3 & 4) to apply pressure supplied from inlet port to ends of control valve spools.
- ③ Tank port (T) necessary to control the above output pressure.
- ④ Spool to connect output port to inlet port or tank port.
- ⑤ Mechanical means to control output pressure, including springs that work on the above spools.

(2) Functions of major sections

The functions of the spool (4) are to receive the supply oil pressure from the hydraulic pump at its port P, and to change over oil paths to determine whether the pressure oil of port P is led to output ports 1, 2, 3 & 4 or the output port pressure oil to tank port T.

The spring (6) works on this spool to determine the output pressure.

The change the deflection of this spring, the push rod (9,11) is inserted and can slide in the plug (14).

For the purpose of changing the displacement of the push rod through the swash plate (20) and adjusting nut (21) are provided the handle (23) that can be tilted in any direction around the fulcrum of the universal joint (19) center.

The spring (10) works on the case (1) and spring seat (7, 13) and tries to return the push rod (9,11) to the zero-displacement position irrespective of the output pressure, securing its resetting to the center position.

This also has the effect of a reaction spring to give appropriate control feeling to the operator.

3) OPERATION

The operation of the pilot valve will be described on the basis of the hydraulic circuit diagram shown below and the attached operation explanation drawing.

The diagram shown below is the typical application example of the pilot valve.

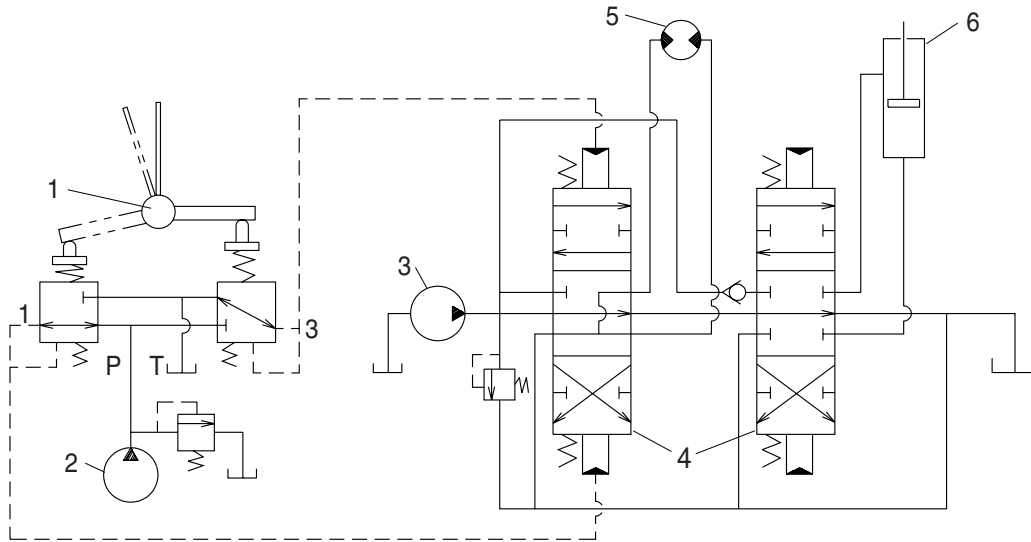

2-70

- 1 Pilot valve
- 2 Pilot pump

- 3 Main pump
- 4 Main control valve

- 5 Hydraulic motor
- 6 Hydraulic cylinder

(1) Case where handle is in neutral position

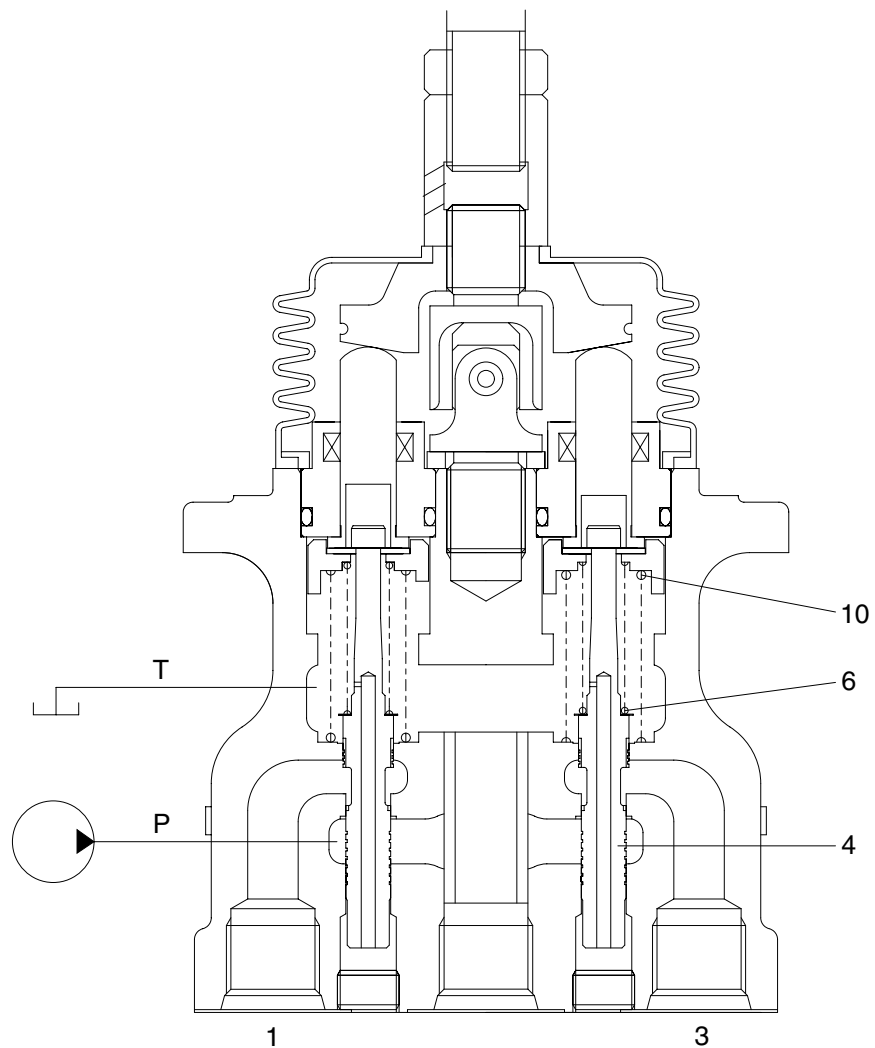

21092RL03

The force of the spring (6) that determines the output pressure of the pilot valve is not applied to the spool (4). Therefore, the spool is pushed up by the spring (10) to the position of port (1, 3) in the operation explanation drawing. Then, since the output port is connected to tank port T only, the output port pressure becomes equal to tank pressure.

(2) Case where handle is tilted

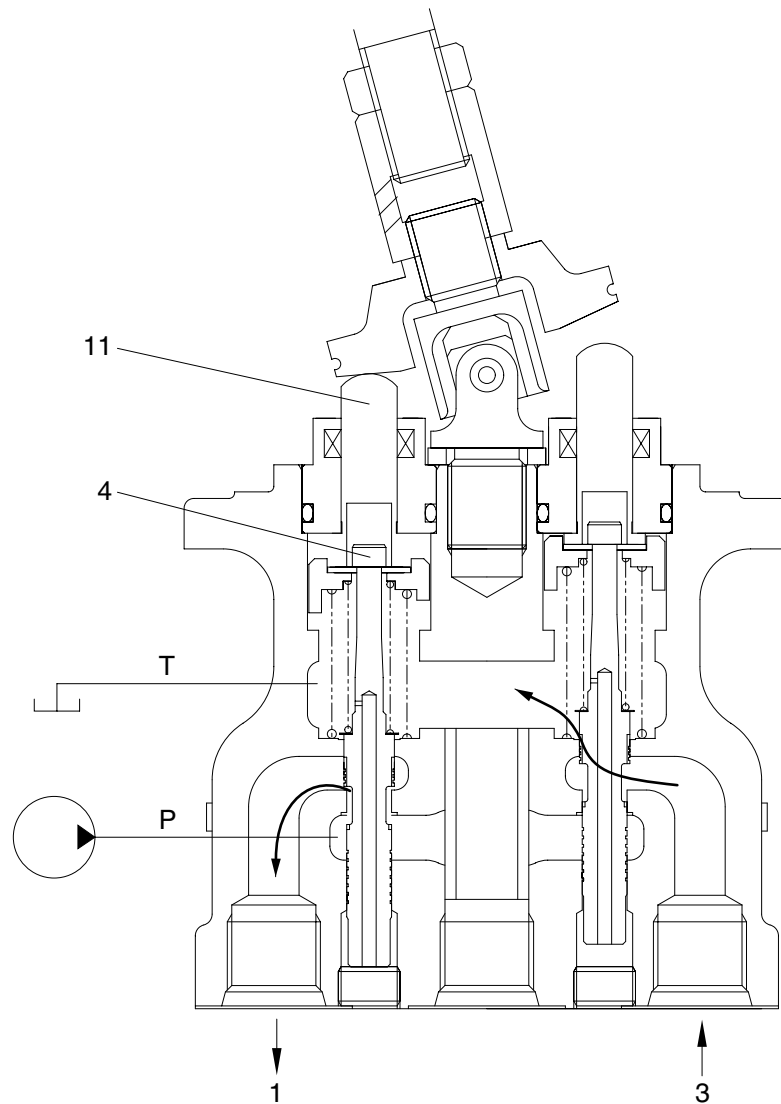

21092RL04

When the push rod (11) is stroked, the spool (4) moves downwards.

Then port P is connected with port (1) and the oil supplied from the pilot pump flows through port (1) to generate the pressure.

When the pressure at port (1) increases to the value corresponding to the spring force set by tilting the handle, the hydraulic pressure force balances with the spring force. If the pressure at port (1) increases higher than the set pressure, port P is disconnected from port (1) and port T is connected with port (1). If it decreases lower than the set pressure, port P is connected with port (1) and port T is disconnected from port 1.

In this manner the secondary pressure is kept at the constant value.

Besides, in some type, when the handle is tilted more than a certain angle, the upper end of the spool contacts with the inside bottom of the push rod and the output pressure is left to be connected with port P.

9. LOADER CYLINDERS

1) BOOM CYLINDER

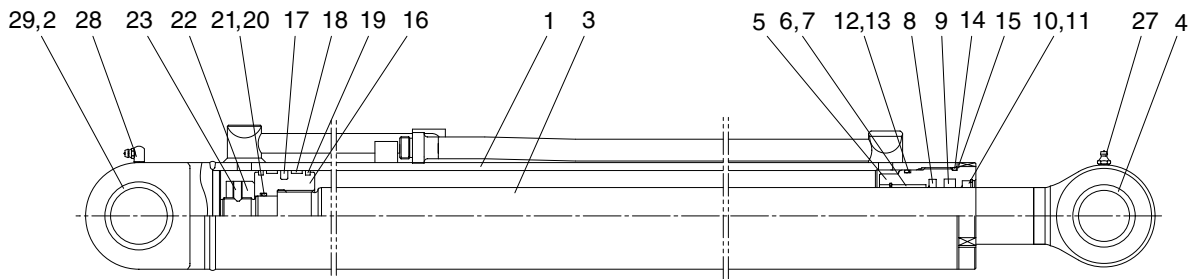

HB100WE135

1	Tube assembly	9	U-packing	17	Piston seal
2	Pin bushing	10	Dust wiper	18	Wear ring
3	Rod assembly	11	Retaining ring	19	Dust ring
4	Pin bushing	12	O-ring	20	O-ring
5	Rod cover	13	Back up ring	21	Back up ring
6	Rod bushing	14	O-ring	22	Piston nut
7	Retaining ring	15	Washer	23	Set screw
8	Buffer seal	16	Piston	27	Grease nipple

2) BUCKET CYLINDER

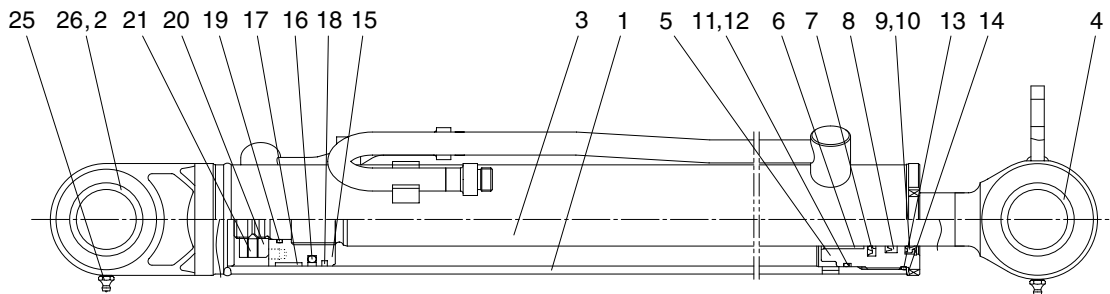

HB100WE136

1	Tube assembly	9	Dust wiper	17	Wear ring
2	Pin bushing	10	Retaining ring	18	Dust ring
3	Rod assembly	11	O-ring	19	O-ring
4	Pin bushing	12	Back up ring	20	Piston nut
5	Rod cover	13	O-ring	21	Set screw
6	Rod bushing	14	Washer	25	Grease nipple
7	Buffer seal	15	Piston		
8	U-packing	16	Piston seal		

3) CLAM CYLINDER (OPTION)

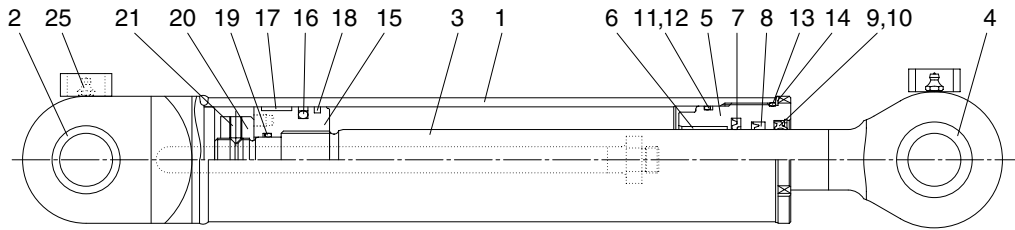

HB100WE137

- | | | | | | |
|---|---------------|----|----------------|----|---------------|
| 1 | Tube assembly | 9 | Dust wiper | 17 | Wear ring |
| 2 | Pin bushing | 10 | Retaining ring | 18 | Dust ring |
| 3 | Rod assembly | 11 | O-ring | 19 | O-ring |
| 4 | Pin bushing | 12 | Back up ring | 20 | Piston nut |
| 5 | Rod cover | 13 | O-ring | 21 | Set screw |
| 6 | Rod bushing | 14 | Washer | 25 | Grease nipple |
| 7 | Buffer seal | 15 | Piston | | |
| 8 | U-packing | 16 | Piston seal | | |

10. BACKHOE CYLINDERS

1) BOOM CYLINDER

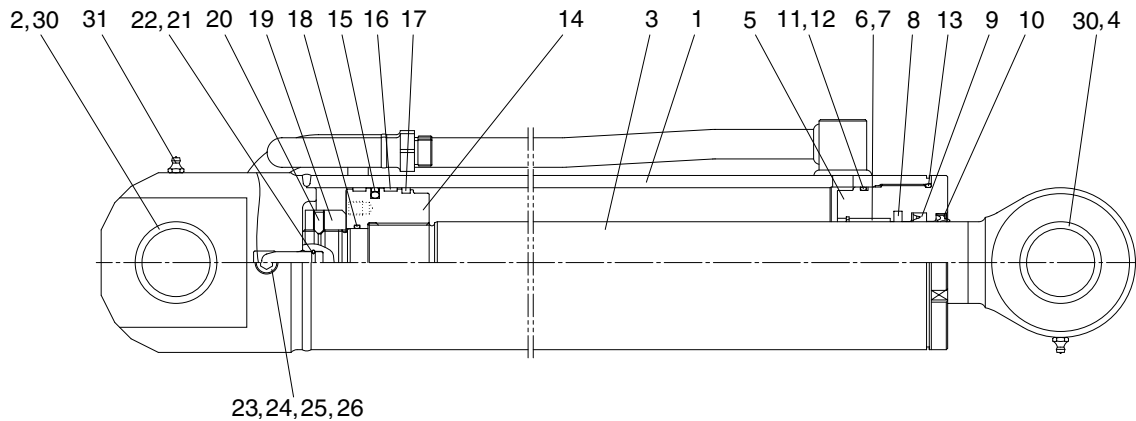

HB100WE130

1	Tube assembly	11	O-ring	21	Cushion plunger
2	Pin bushing	12	Back up ring	22	Stop ring
3	Rod assembly	13	O-ring	23	Check
4	Pin bushing	14	Piston	24	Spring
5	Rod cover	15	Piston seal	25	Spring support
6	Rod bushing	16	Wear ring	26	Hex socket plug
7	Retaining ring	17	Dust ring	30	Pin wiper
8	Buffer seal	18	O-ring	31	Grease nipple
9	U-packing	19	Piston nut		
10	Dust wiper	20	Set screw		

2) DIPPER CYLINDER

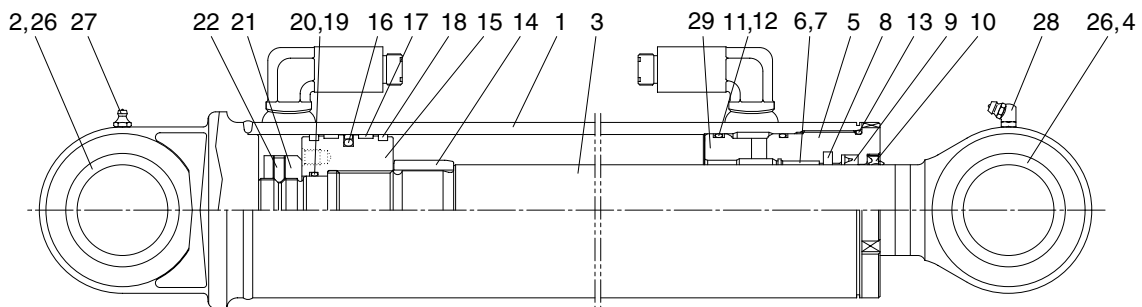

HB100WE131

1	Tube assembly	10	Dust wiper	19	O-ring
2	Pin bushing	11	O-ring	20	Back up ring
3	Rod assembly	12	Back up ring	21	Piston nut
4	Pin bushing	13	O-ring	22	Set screw
5	Rod cover	14	Cushion ring	26	Pin wiper
6	Rod bushing	15	Piston	27	Grease nipple
7	Retaining ring	16	Piston seal	28	Grease nipple
8	Buffer seal	17	Wear ring		
9	U-packing	18	Dust ring		

3) BUCKET CYLINDER

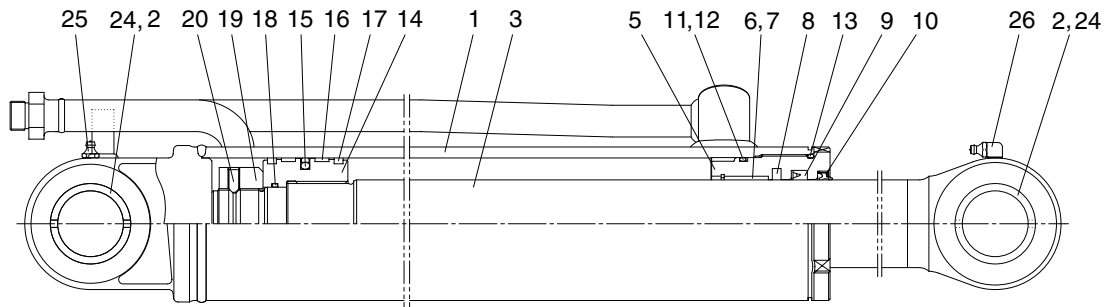

HB100WE132

- | | | | | | |
|---|----------------|----|--------------|----|---------------|
| 1 | Tube assembly | 9 | U-packing | 17 | Dust ring |
| 2 | Pin bushing | 10 | Dust wiper | 18 | O-ring |
| 3 | Rod assembly | 11 | O-ring | 19 | Piston nut |
| 4 | Pin bushing | 12 | Back up ring | 20 | Set screw |
| 5 | Rod cover | 13 | O-ring | 24 | Pin wiper |
| 6 | Rod bushing | 14 | Piston | 25 | Grease nipple |
| 7 | Retaining ring | 15 | Piston seal | 26 | Grease nipple |
| 8 | Buffer seal | 16 | Wear ring | | |

4) BOOM SWING CYLINDER

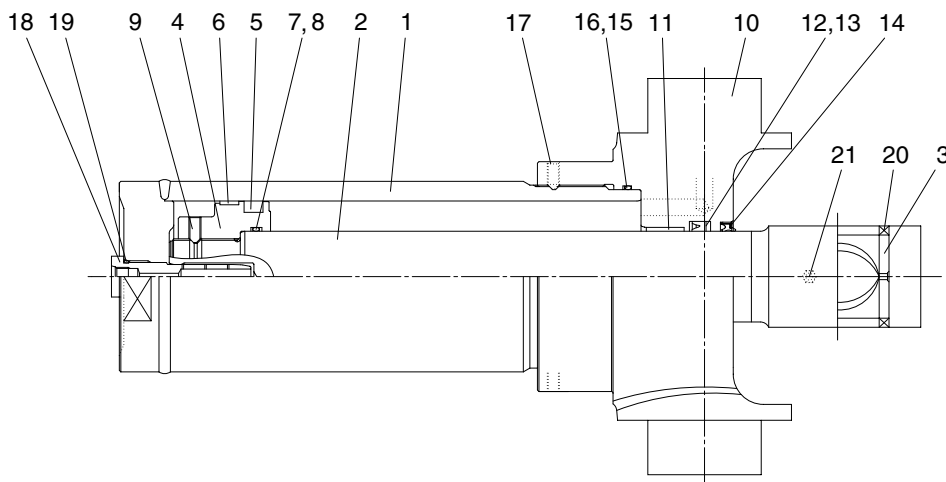

HB100WE133

- | | | | | | |
|---|---------------|----|--------------|----|-----------------|
| 1 | Tube assembly | 8 | Back up ring | 15 | O-ring |
| 2 | Rod assembly | 9 | Set screw | 16 | Back up ring |
| 3 | Pin bushing | 10 | Rod cover | 17 | Set screw |
| 4 | Piston | 11 | Rod bushing | 18 | Cushion plunger |
| 5 | Piston seal | 12 | U-packing | 19 | O-ring |
| 6 | Wear ring | 13 | Back up ring | 20 | Pin wiper |
| 7 | O-ring | 14 | Dust wiper | 21 | Grease nipple |

5) STABILIZER CYLINDER

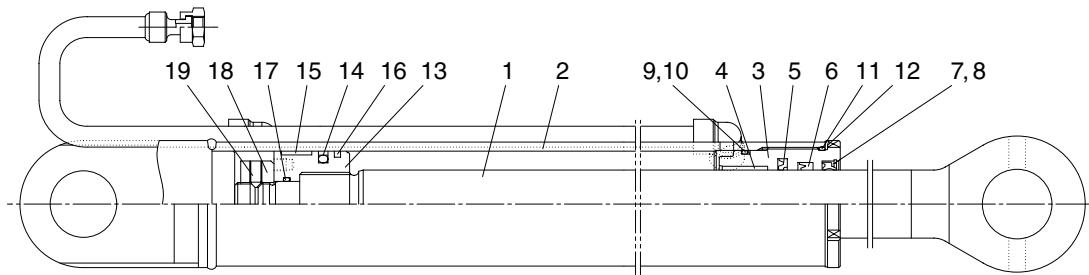

HB100WE134

- | | | | | | |
|---|---------------|----|----------------|----|------------|
| 1 | Tube assembly | 8 | Retaining ring | 15 | Wear ring |
| 2 | Rod assembly | 9 | Set screw | 16 | Dust ring |
| 3 | Rod cover | 10 | Back up ring | 17 | O-ring |
| 4 | Pin bushing | 11 | O-ring | 18 | Piston nut |
| 5 | Buffer seal | 12 | Washer | 19 | Set screw |
| 6 | U-packing | 13 | Piston | | |
| 7 | Dust wiper | 14 | Piston seal | | |

6) EXTENSION CYLINDER (OPTION)

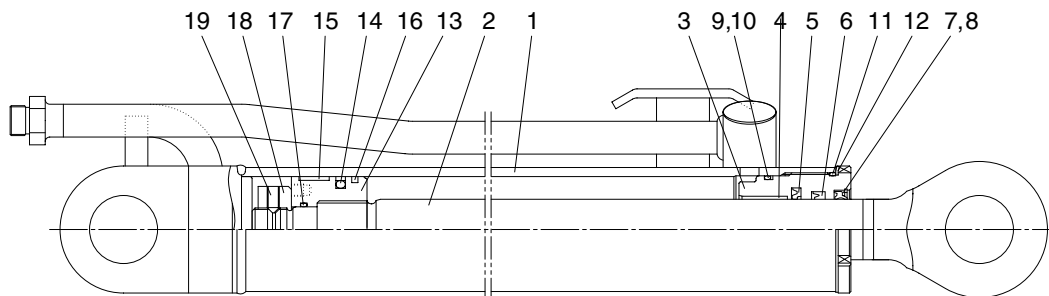

HB100WE138

- | | | | | | |
|---|---------------|----|----------------|----|------------|
| 1 | Tube assembly | 8 | Retaining ring | 15 | Wear ring |
| 2 | Rod assembly | 9 | O-ring | 16 | Dust ring |
| 3 | Rod cover | 10 | Back up ring | 17 | O-ring |
| 4 | Rod bushing | 11 | O-ring | 18 | Piston nut |
| 5 | Buffer seal | 12 | Washer | 19 | Set screw |
| 6 | U-packing | 13 | Piston | | |
| 7 | Dust wiper | 14 | Piston seal | | |

11. HYDRAULIC OIL TANK

1) STRUCTURE

- The oil from the hydraulic tank is sent from the pump through main control valve to the cylinders. In the return circuit, the oil from various parts merges.
- A part of oil is cooled in the oil cooler (If equipped), passes through the hydraulic filter and returns to the hydraulic tank (1).
- If the hydraulic return oil filter becomes clogged, return filter bypass valve (7) acts to allow the oil to return directly to the hydraulic tank (1). This prevents damage to the hydraulic filter (5). The bypass valve (7) is also actuated when negative pressure is generated in the circuit.

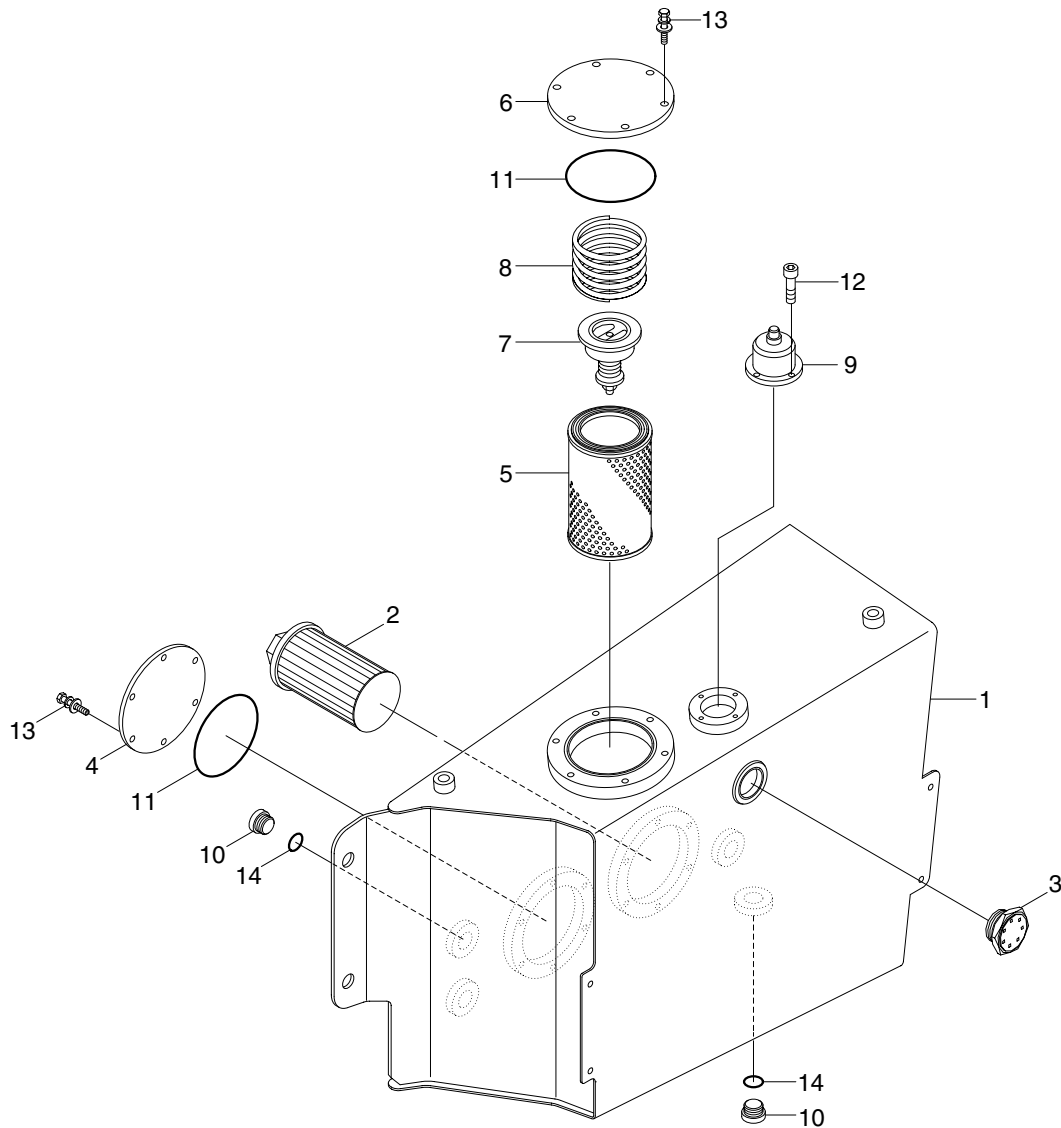

HB100WE23

1	Hydraulic tank	6	Cover	11	O-ring
2	Suction strainer	7	By pass valve	12	Socket bolt
3	Sight gauge	8	Spring	13	Bolt
4	Cover	9	Air breather	14	O-ring
5	Element assy	10	Plug		

2) RETURN OIL FILTER BYPASS VALVE

(1) When the filter is clogged

Bypass valve (1) is opened and the oil returns directly to the tank without passing through the filter.

Bypass valve set pressure : 1.36 kg/cm²
(19.3 psi)

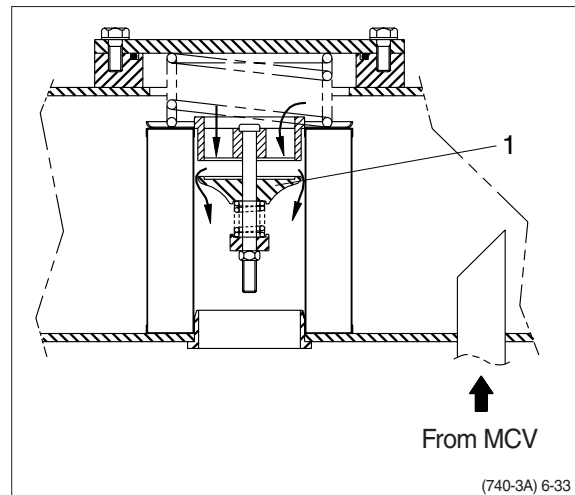

3) AIR BREATHER

The air breather is equipped with the capacity to perform three functions simultaneously-as an air filter, breathing valve, and as a lubrication opening.

(1) Preventing negative pressure inside the tank

The tank is a pressurized sealed type, so negative pressure is formed inside the hydraulic tank when the oil level drops during operations. When this happens, the difference in pressure between the tank and the outside atmospheric pressure opens the poppet in the breather, and air from the outside is let into the tank or prevent negative pressure.

(2) Preventing excessive pressure inside the tank

When the hydraulic cylinder is being used, the oil level in the hydraulic system increases and as temperature rises. If the hydraulic pressure rises above the set pressure, breather is actuated to release the hydraulic pressure inside the tank.

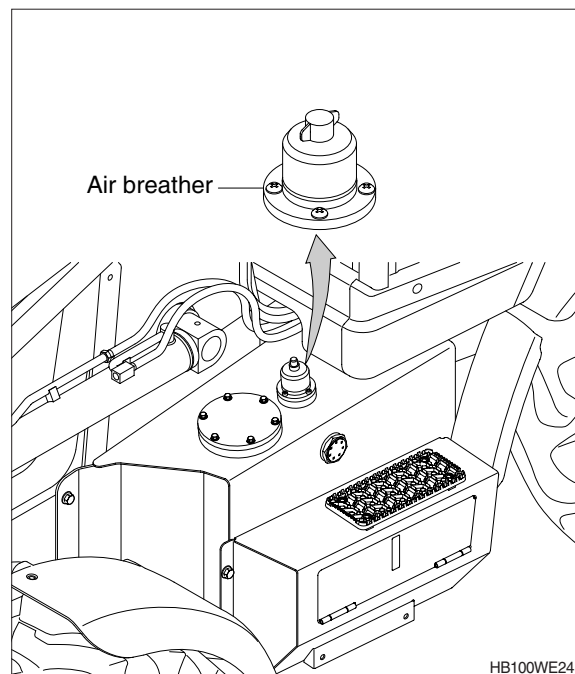

12. ACCUMULATOR

The accumulator is installed at the pilot oil supply unit. When the boom is left the raised position, and the control levers are operated with the engine stopped the pressure of the compressed nitrogen gas inside the accumulator sends pilot pressure to the control valve to actuate it and allow the boom and bucket to come down under their own weight.

Type of gas	Nitrogen gas (N ₂)
Volume of gas	0.35 l (0.1 U.S.gal)
Charging pressure of gas	15 kg/cm ² (213 psi)
Max actuating pressure	170 kg/cm ² (2420 psi)

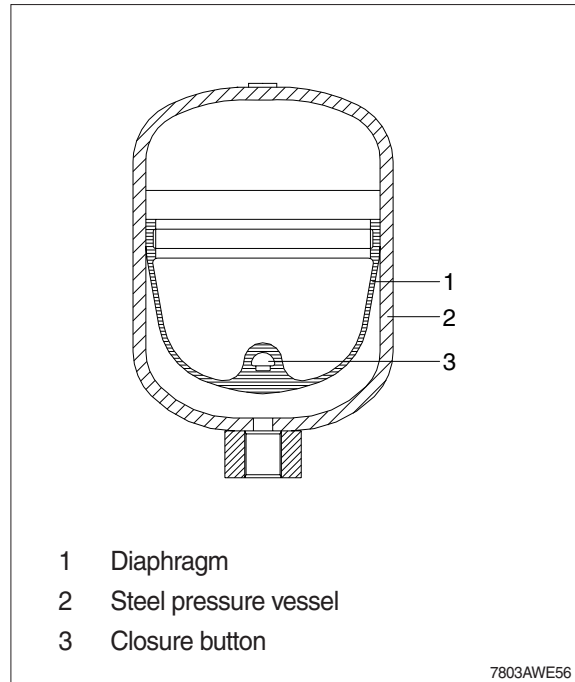

13. RIDE CONTROL VALVE

Item	Description
Diameter	125 mm
Mounting height	403 mm
Capacity	1.5 l
Max working pressure	357 kgf/cm ²
Precharge pressure (at 20°C)	31 ± 1 kgf/cm ²
Precharge gas	Nitrogen
Portsize (A, B, T)	3/4-16UNF

