

GROUP 4 DISASSEMBLY AND ASSEMBLY

1. TRANSMISSION

1) DISASSEMBLY

Solenoid valves, inductive sensor, screw plugs and nozzles (orifices)

(1) Loosen cylindrical screws, remove bracket and pull solenoid valves off the holes.

※ Mark solenoid valves (different versions).

1 = Y1 (control valve)

2 = YPB (parking brake - rear axle)

3 = YDL (differential lock - rear axle)

4 = Y3 (control valve)

5 = Y2 (control valve)

6 = Y5 (control valve)

7 = Y4 (control valve)

8 = Y6 (control valve)

9 = YWD (front wheel drive)

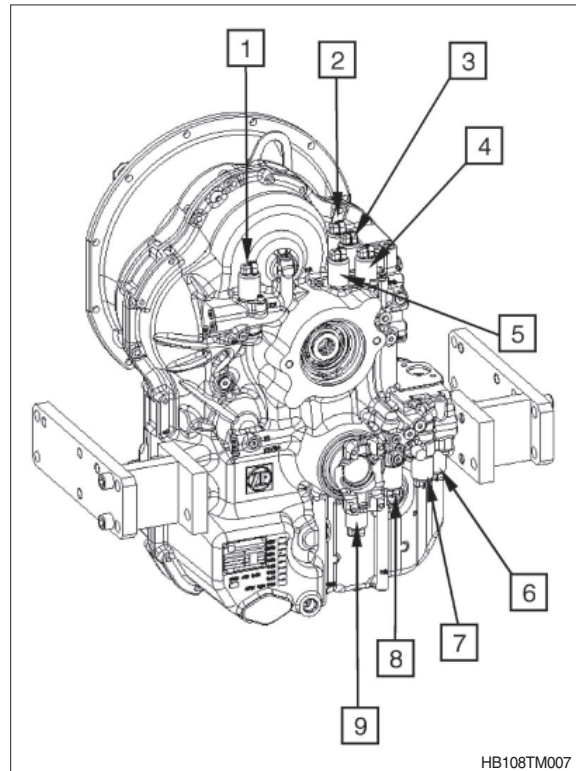

※ Version with inductive sensor (option).

(2) Loosen inductive sensor (1).

※ Remove O-ring.

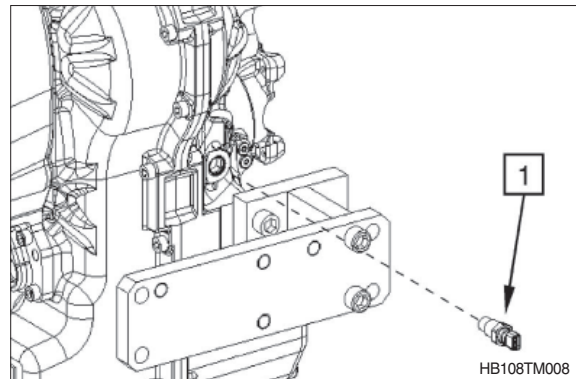

(3) Pull output flange (1) off the output shaft.

※ Remove all screw plugs and nozzles (orifices).

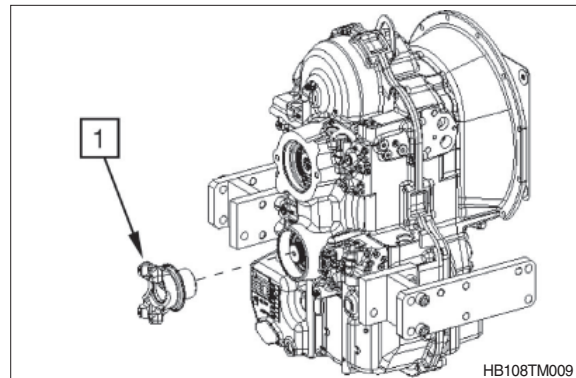

2) DISASSEMBLY OF ENGINE CONNECTION, MAIN PRESSURE VALVE AND CONVERTER SAFETY VALVE

(1) Engine connection

- ① Loosen hexagon screws (1) and separate flexplate (2) from converter (3).

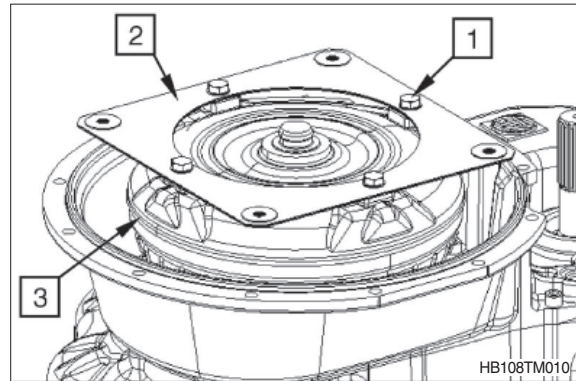

- ② Pull off converter (1) by hand.

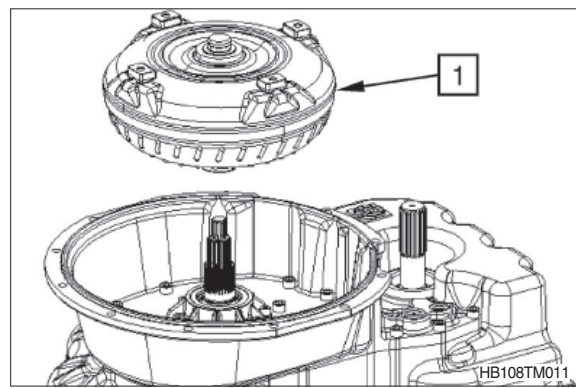

- ③ Loosen bolted connection between converter bellhousing/housing (1) and transmission pump/housing (2).

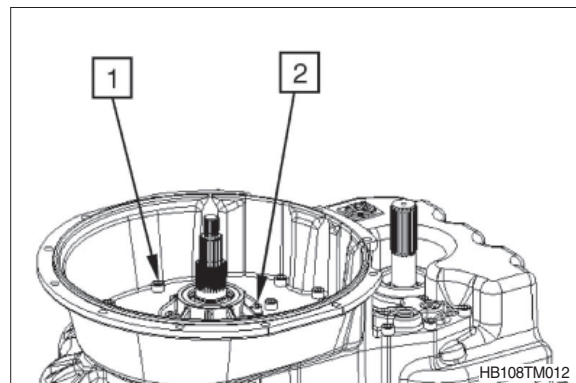

- ④ Loosen screw plug "measuring point 63" (1).

※ Remove O-ring.

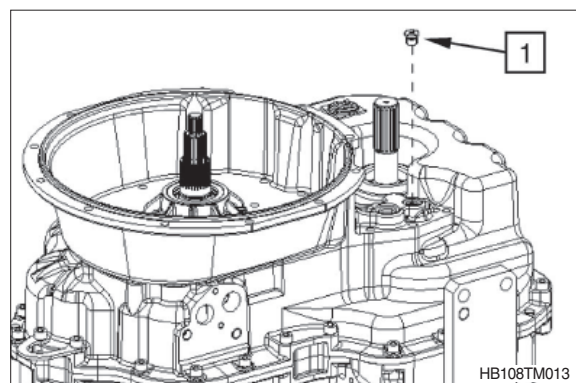

- ⑤ Separate converter bellhousing from the mounting face of the transmission housing by means of slight hits with a plastic hammer.

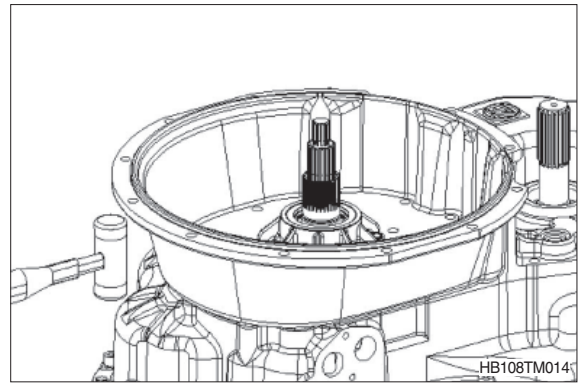

- ⑥ Remove converter bellhousing by means of assembly lever.
- ※ Difficult disassembly due to fixing by cylindrical pins.

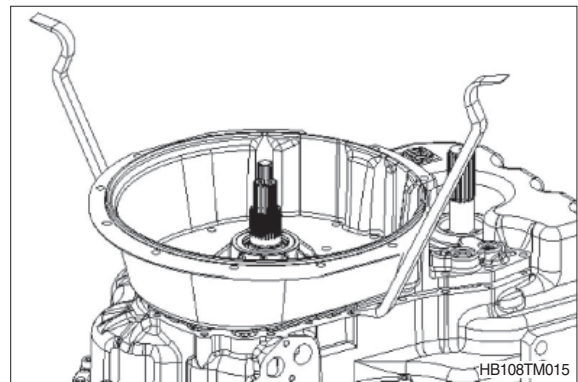

- ⑦ If required, remove both cylindrical pins (1).
- ⑧ Remove filter (2).

- ※ Transmission pump cannot be separated from the housing until the 4 cylindrical screws of the housing inner side have been loosened.

Fit adjusting screws to ensure that the transmission pump is centered at the housing after the 4 cylindrical screws have been loosened.

(S) Adjusting screws (M10) 5870 204 007

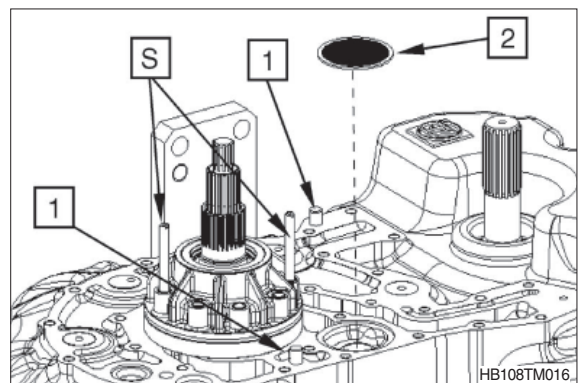

(2) Main pressure valve and converter safety valve

- ① Loosen screw plug (1) and remove main pressure valve (control pressure valve) :

Main pressure valve consists of:

- 1 = Screw plug
- 2 = O-ring
- 3 = Piston
- 4 = Spacer ring
- 5 = Compression spring

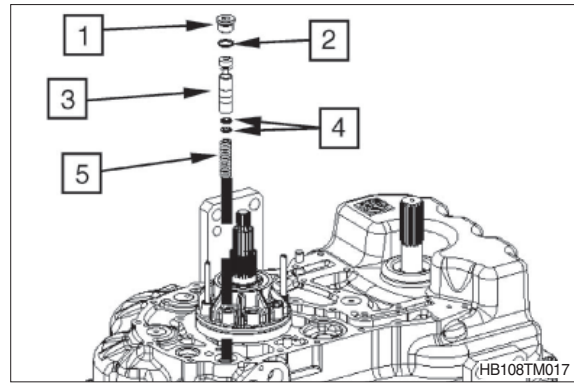

- ※ Functional check of converter safety valve (1).
Use a screwdriver to check the movability of the ball in the valve.
- ※ If the valve is o.k., it does not need to be removed.
- ※ Valve assy is installed in the housing-not visible.

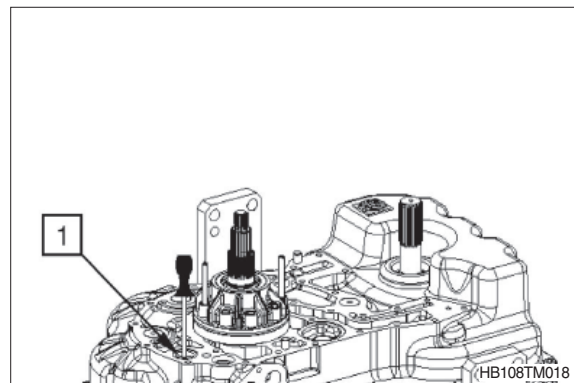

3) REMOVAL OF CLUTCHES, CENTRAL SHAFT AND DISASSEMBLY OF TRANSMISSION PUMP

(1) Removal of clutches

- ① Force out cylindrical pins (1).
Loosen bolted connection (2) of housing front and rear part.

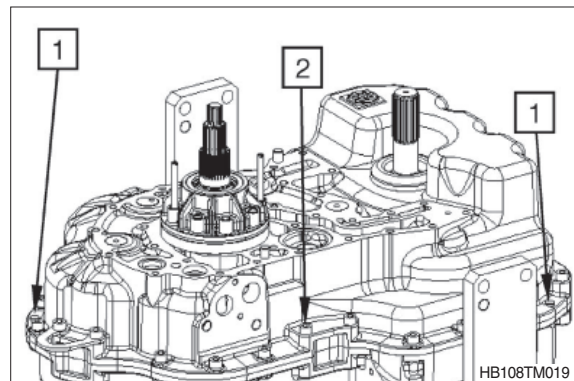

- ② Separate housing front part from transmission housing rear part by means of lifting device (approx. 1 cm).
- ③ Use the plastic hammer to reset the output shaft (1) of the front wheel drive to its initial position, thus separating the screen sheet (2) from the shaft of the clutch.

(S) Eye bolts assortment 5870 204 002

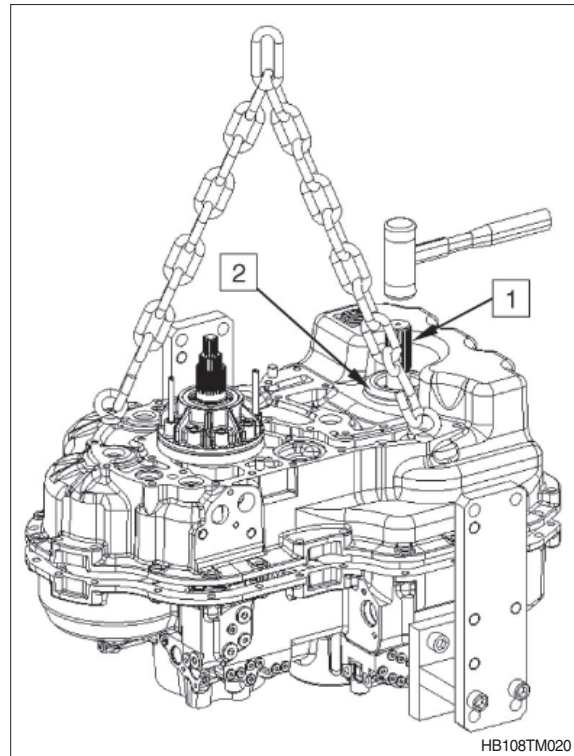

- ④ Remove screen sheet (1) and separate transmission housing front part by means of lifting device.

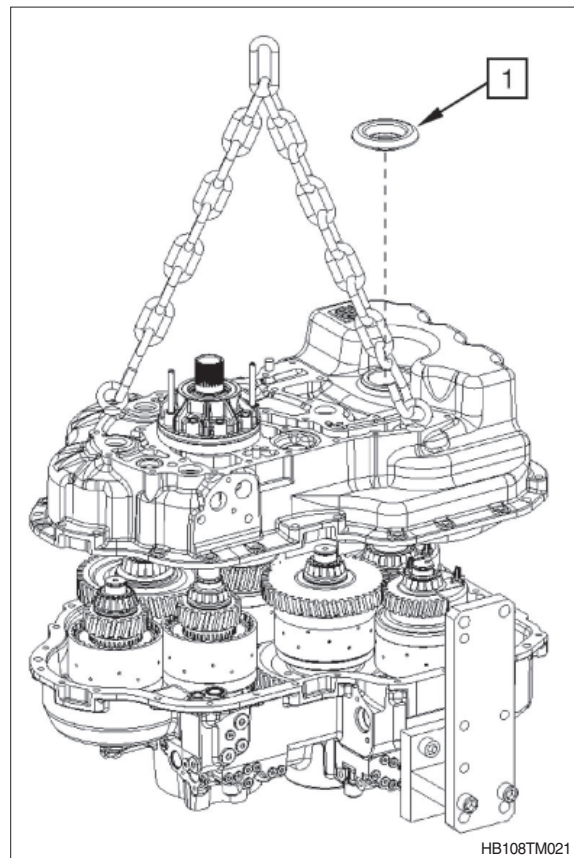

- ⑤ Designation of clutches:
 KV = Forward clutch (directional clutch)
 KR = Reverse clutch (directional clutch)
 K1 = K1 clutch (gear clutch)
 K2 = K2 clutch (gear clutch)
 K3 = K3 clutch (gear clutch)
 K4 = K4 clutch (directional clutch)
 VA = Front wheel drive clutch

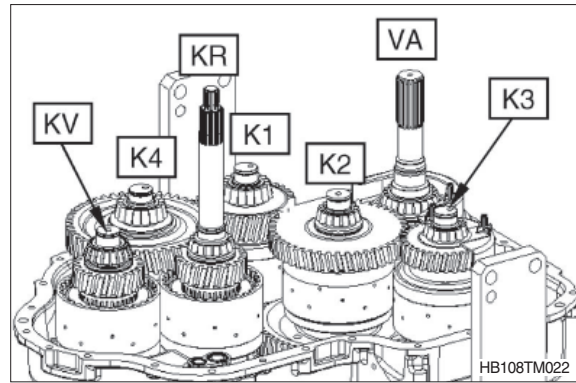

- ⑥ Remove K4 clutch.

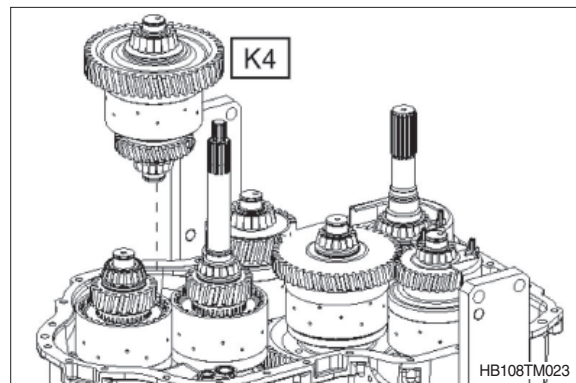

- ⑦ Slightly lift clutch (K2) and remove clutch (K1).

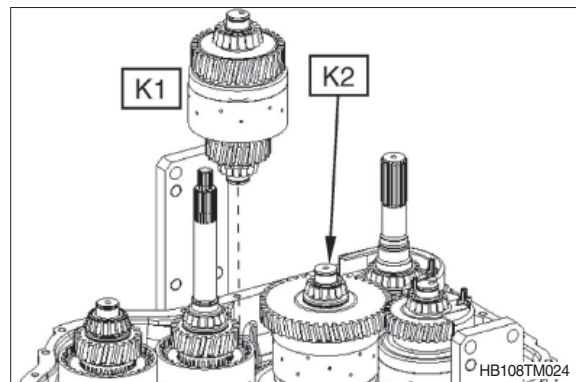

- ⑧ Lift KV and KR clutch off the bearing outer rings jointly and then remove them one after the other.

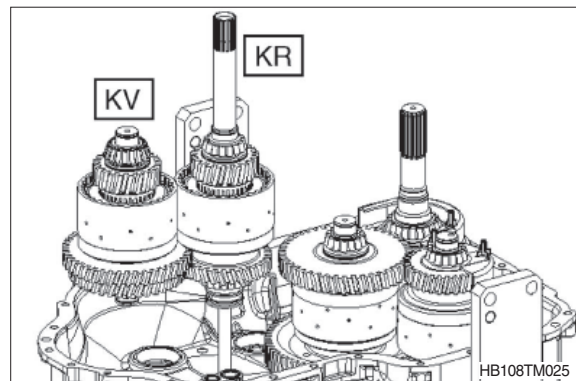

- ⑨ Jointly remove VA, K2 and K3 clutch together with screen sheet (1).
- ⑩ Use the lifting device to jointly lift VA and K3 clutch together with K2 clutch, and then remove the components one after the other.

(S) Eyebolts

5870 204 080

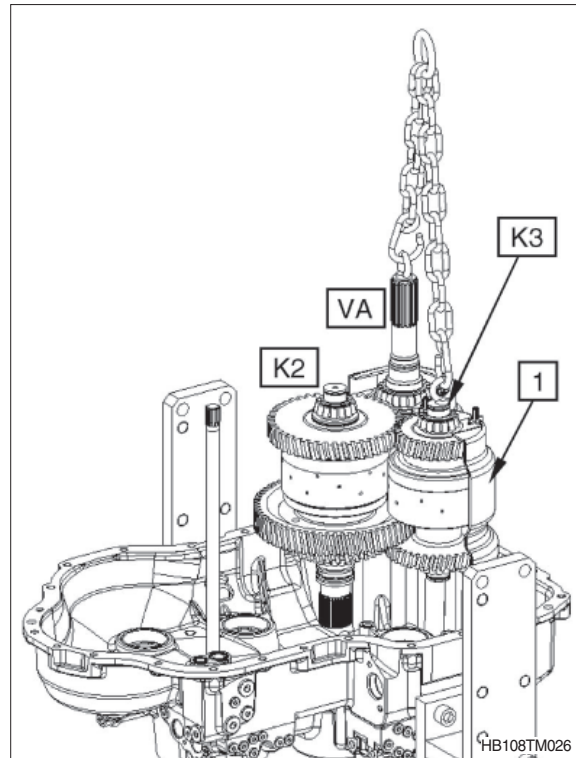

- ⑪ Snap out retaining ring (1) and remove central shaft (2).

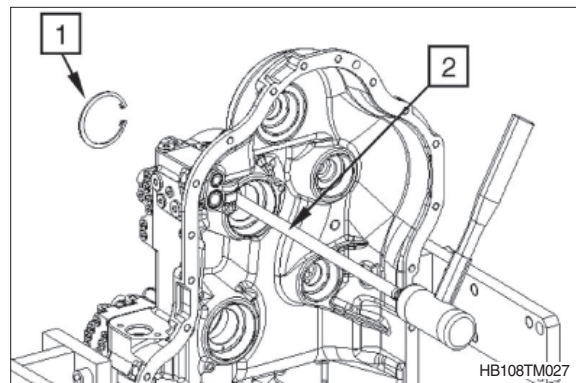

- ⑫ Snap out rectangular ring (1).
- ⑬ Press ball bearing (2) off the central shaft (3).

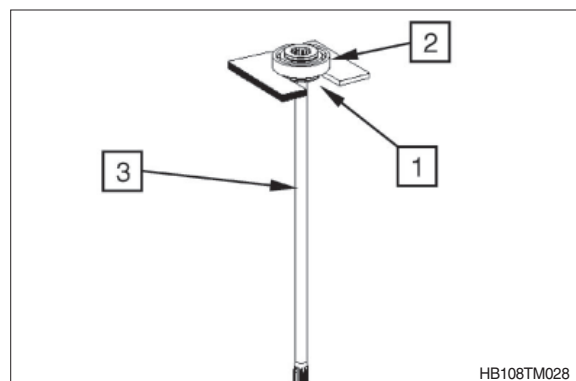

- ⑭ Remove O-rings (1).
- ⑮ Remove all bearing outer rings (2) from the housing rear part.
- ※ If the tapered roller bearings of clutches are not replaced, it is imperative to ensure the previous pairing (bearing outer ring / bearing inner ring).
- ※ Bearing outer ring and bearing inner ring must be marked.

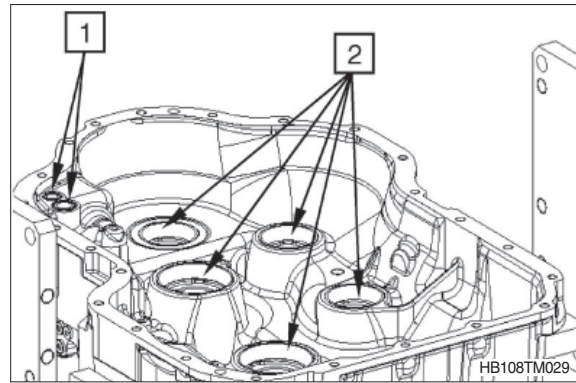

- ⑯ Loosen the cylindrical screws (1) and remove suction tube (2) .
- ⑰ Remove all bearing outer rings (3) from the housing front part.
- ※ If the tapered roller bearings of clutches and input are not replaced, it is imperative to ensure the previous pairing (bearing outer ring / bearing inner ring).
- ※ Bearing outer ring and bearing inner ring must be marked.

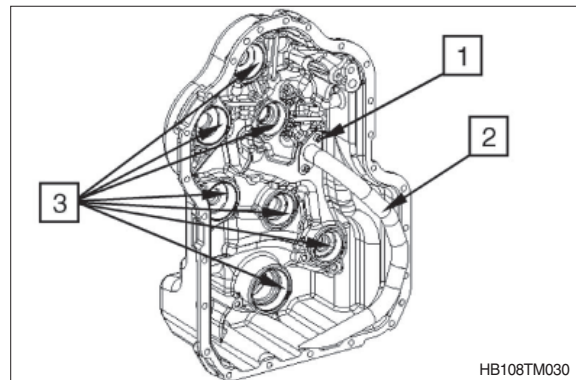

(2) Disassembly of transmission pump

- ① Loosen cylindrical screws (3 and 4) and remove transmission pump.

Pay attention so that the transmission pump does not drop.

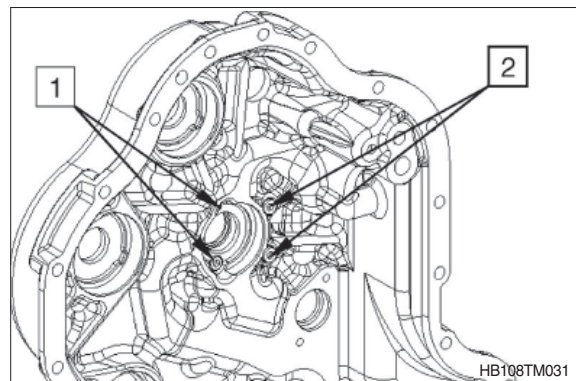

- ② Remove transmission pump (1).

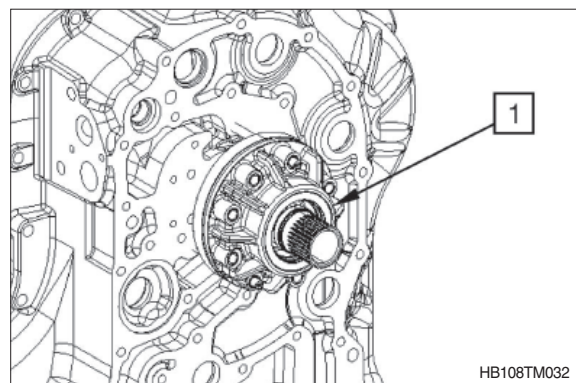

- ③ Remove O-ring (1).
- ④ Loosen cylindrical screws (2).

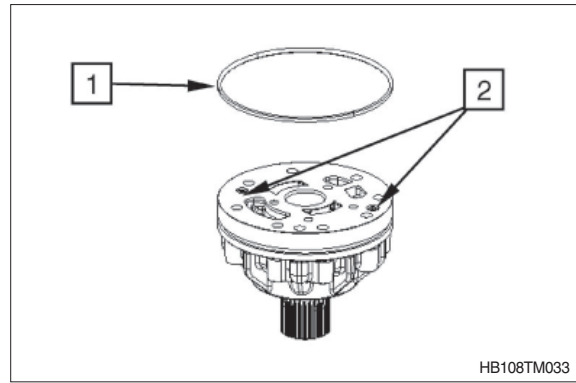

※ **Check transmission pump:**

In case of wear marks in the pump housing, stator hollow shaft or on the inner and outer rotor, the complete transmission pump must be replaced.

- 1 = Stator hollow shaft
- 2 = Inner rotor
- 3 = Outer rotor
- 4 = Pump housing

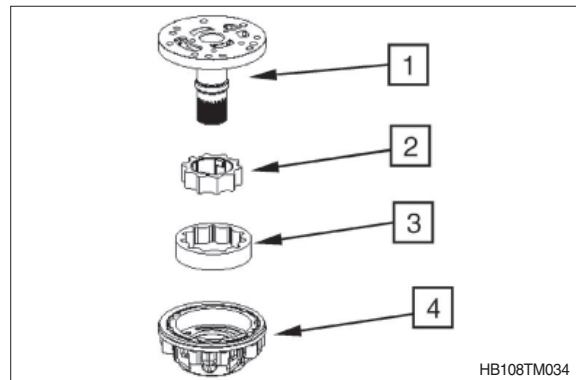

- ⑤ Remove shaft seal ring (1) from the pump housing (2).

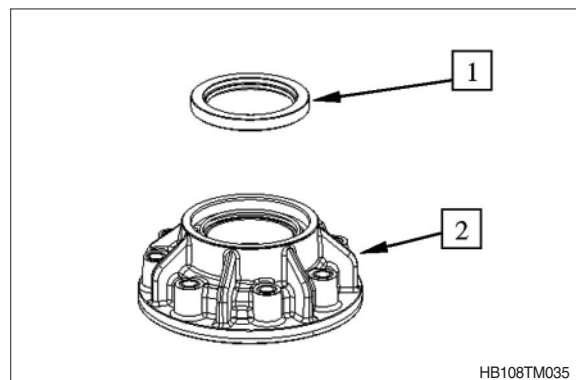

4) DISASSEMBLY CLUTCHES

(1) KR clutch / input

- ① Snap out rectangular ring (1).

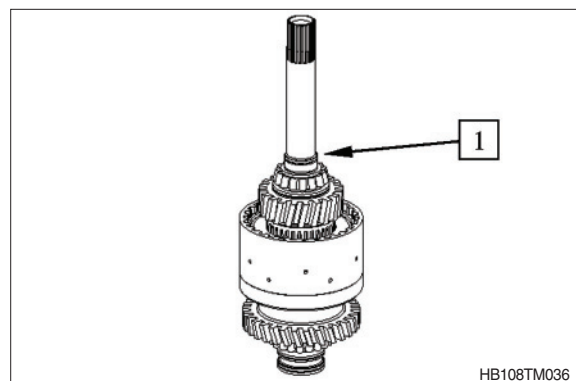

- ② Pull off bearing inner ring with inner disk carrier (1).

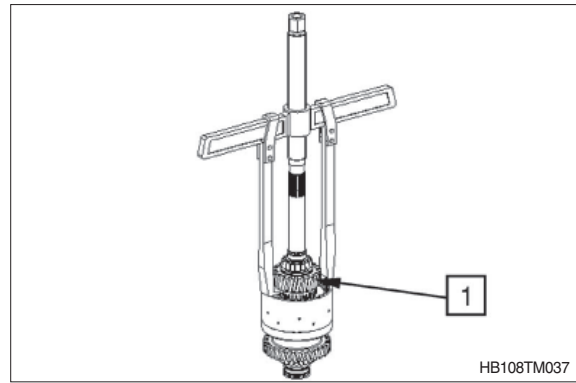

- ③ Remove bearing inner ring (1), axial bearing assembly (2) and inner disk carrier (3).

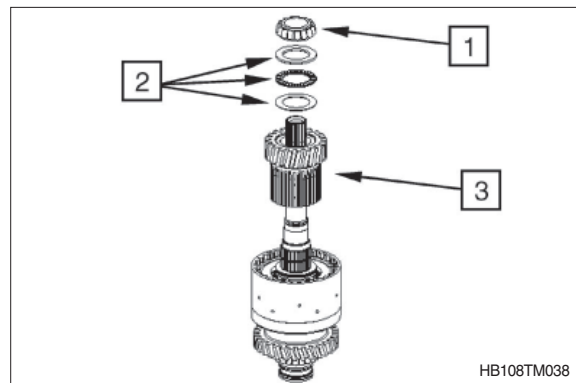

- ④ Remove needle cage (1).

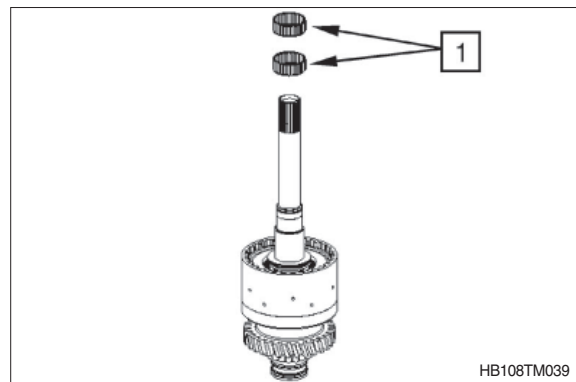

- ⑤ Remove axial bearing assembly (1).

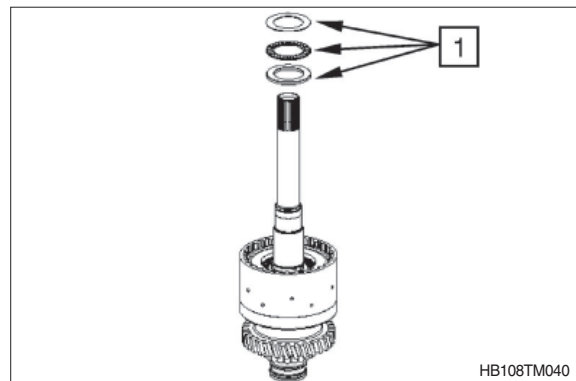

⑥ Remove snap ring (1).

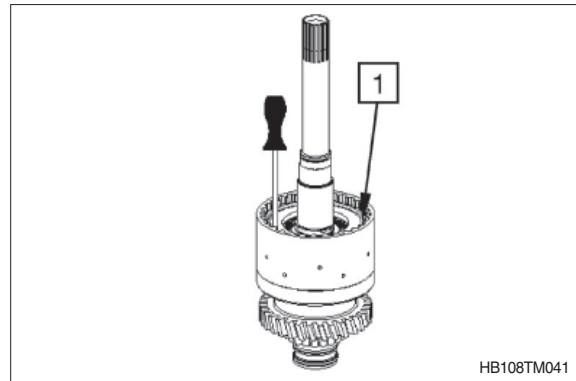

⑦ Remove end plate (1), disk package (2) and plate assy with cup springs (3) from the disk carrier.

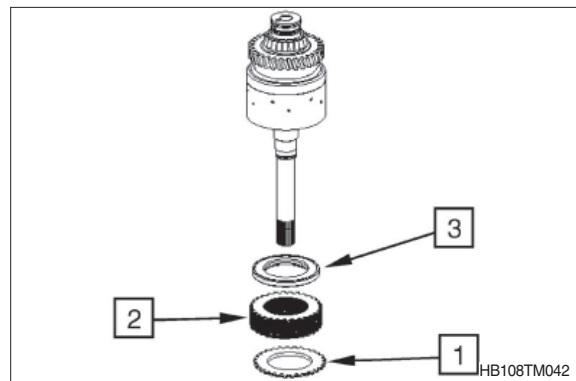

⑧ Remove retaining ring (1) at axial bearing contact.

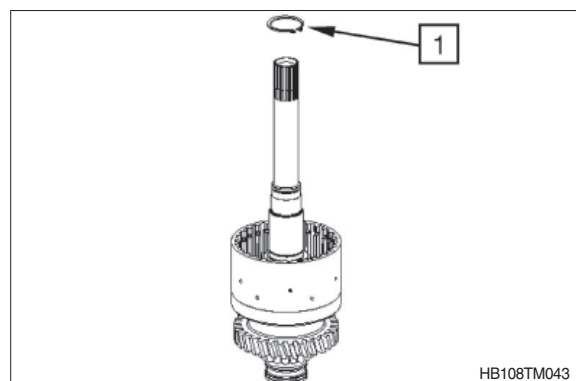

⑨ Preload compression spring and remove snap ring (1).

(S) Assembly aid

5870 345 114

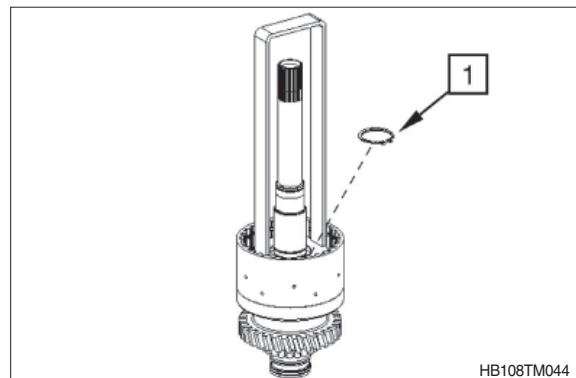

- ⑩ Remove spring cup (1) and compression spring (2).

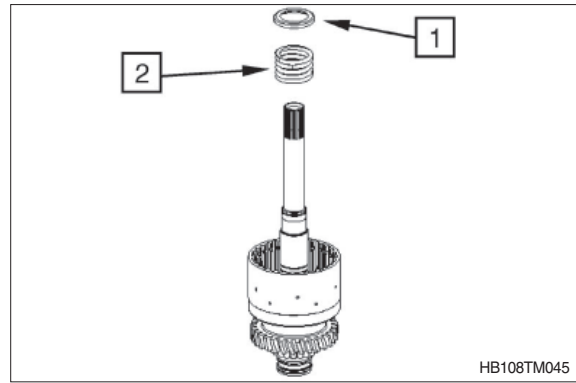

- ⑪ By means of compressed air (see arrow), press piston (1) off the shaft/disk carrier and remove it.

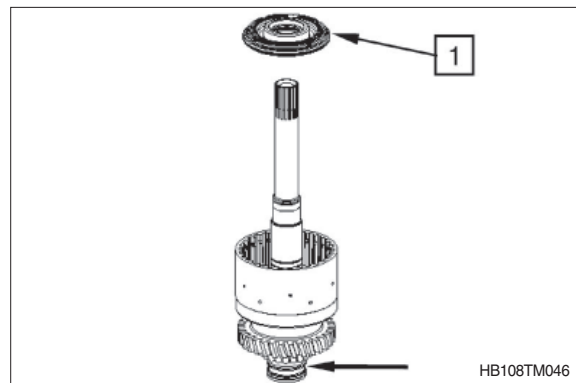

- ⑫ Remove both O-rings (1 and 2).

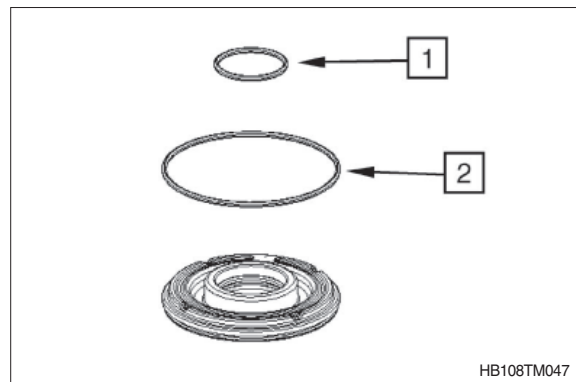

- ⑬ Snap out rectangular rings (1).

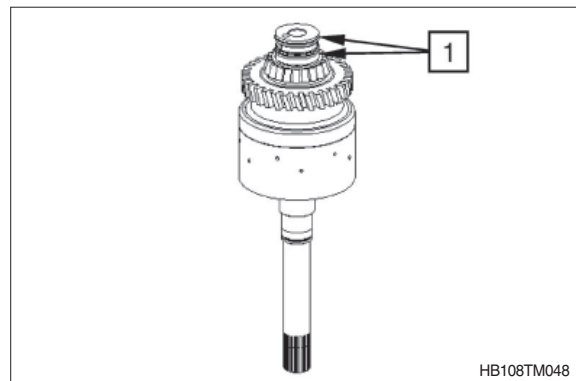

- ⑭ Pull tapered roller bearing (inner ring) off the shaft.

(S) Grab sleeve 5873 001 026

(S) Basic tool 5873 001 000

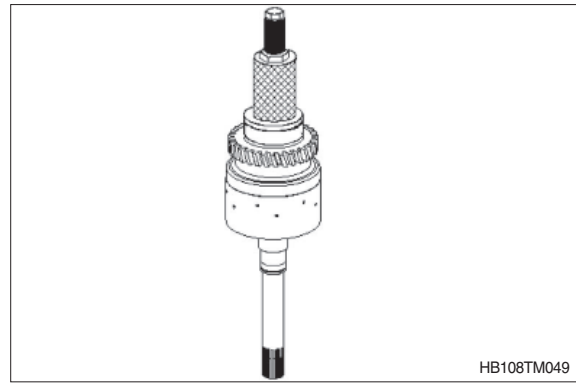

- ※ The input shaft (1) cannot be disassembled.

It is supplied by the spare parts service only as a complete assy which consists of:

1A = Ball

1B = Helical gear

1C = Disk carrier

1D = Input shaft

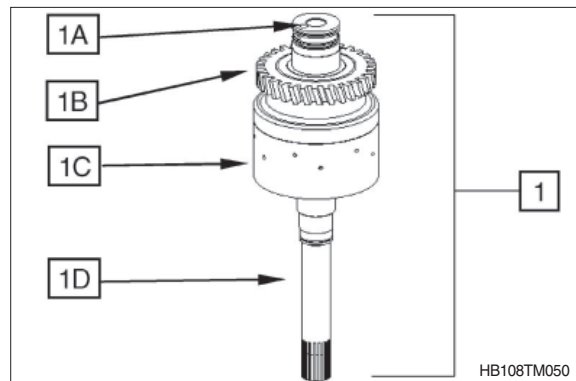

(2) KV clutch

- ① Snap out rectangular ring (1).

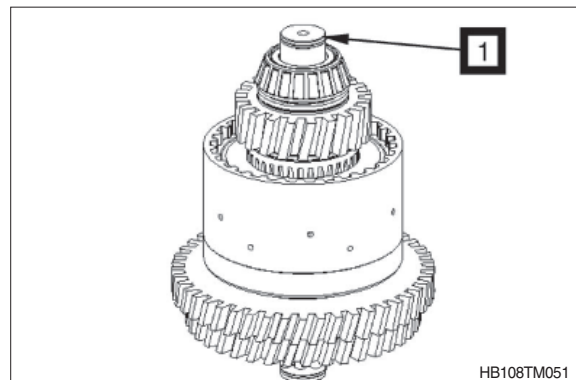

- ② Pull off bearing inner ring with inner disk carrier (1).

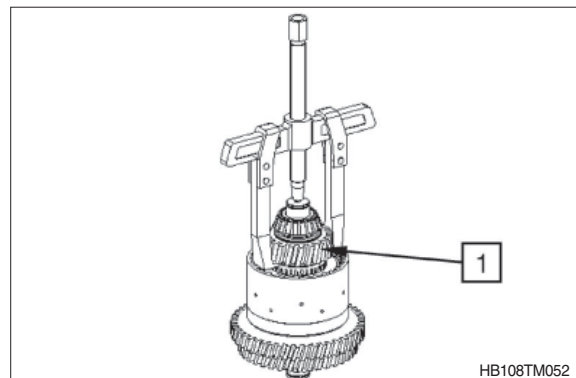

- ③ Remove bearing inner ring (1), axial bearing assy (2) and inner disk carrier (3).

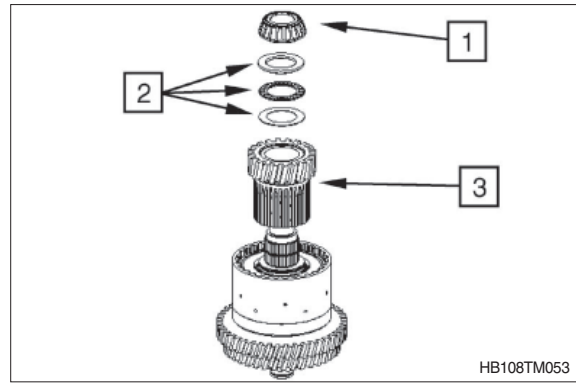

- ④ Remove needle cage (1).

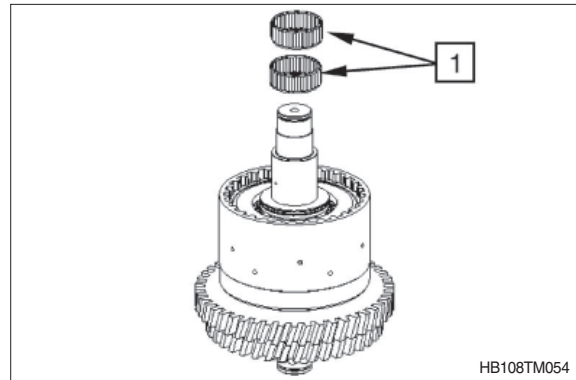

- ⑤ Remove axial bearing assy (1).

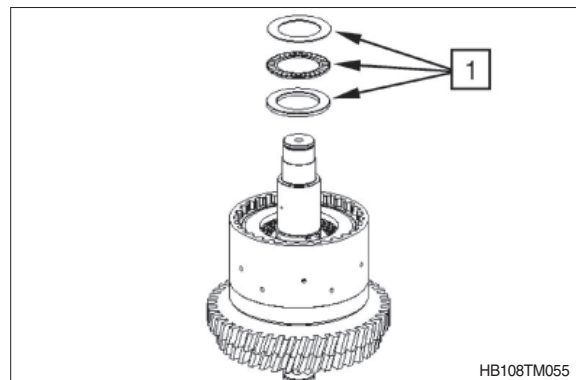

- ⑥ Remove snap ring (1).

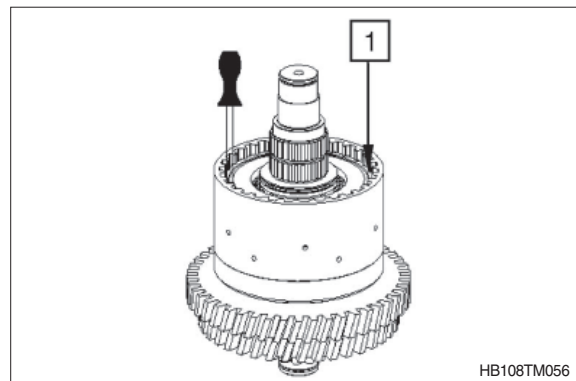

- ⑦ Remove end plate (1), disk package (2) and plate assy with cup springs (3) from the disk carrier.

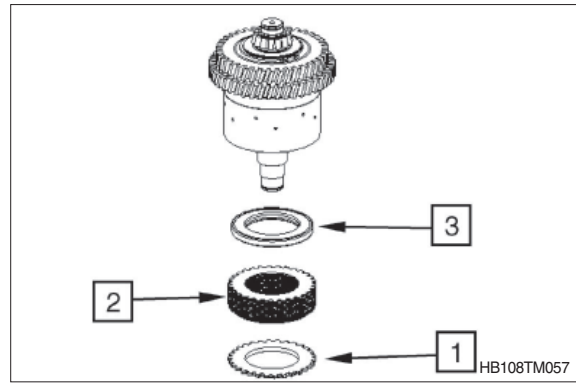

- ⑧ Remove retaining ring (1) at axial bearing contact.

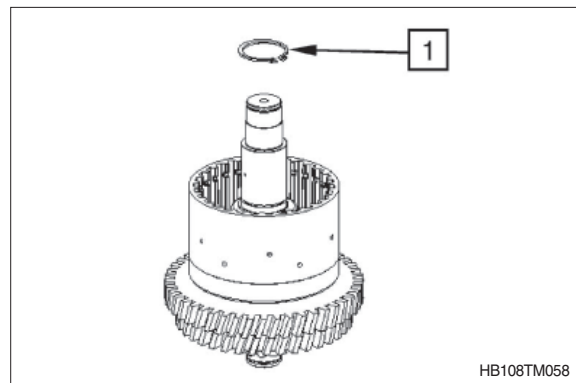

- ⑨ Preload compression spring and remove snap ring (1).

(S) Assembly aid 5870 345 114

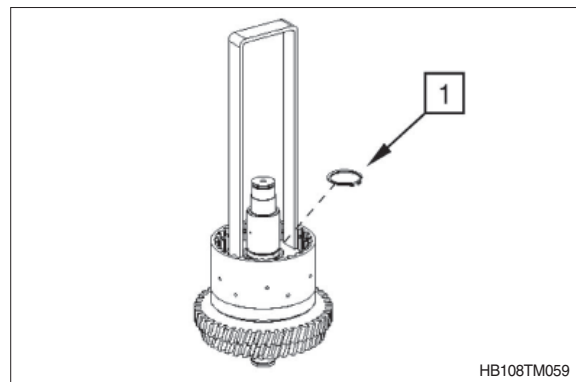

- ⑩ Remove spring cup (1) and compression spring (2).

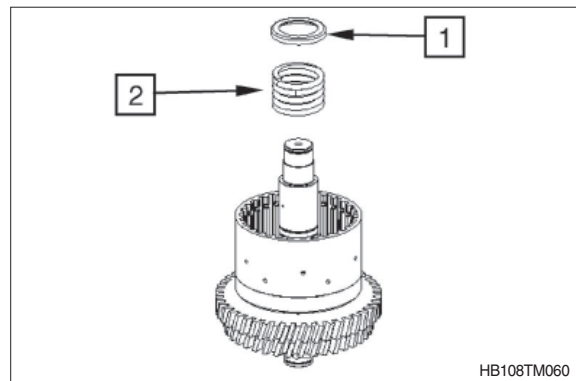

- ⑪ By means of compressed air (see arrow), press piston (1) off the shaft/disk carrier and remove it.

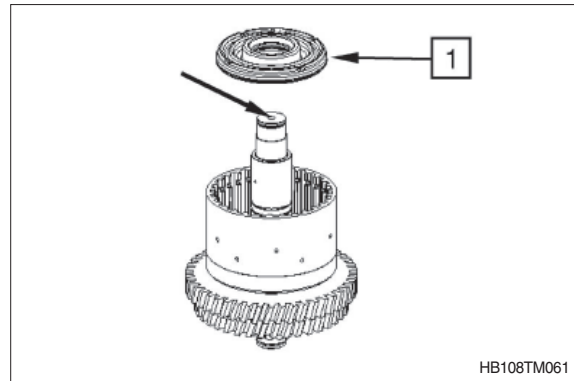

- ⑫ Remove both O-rings (1 and 2).

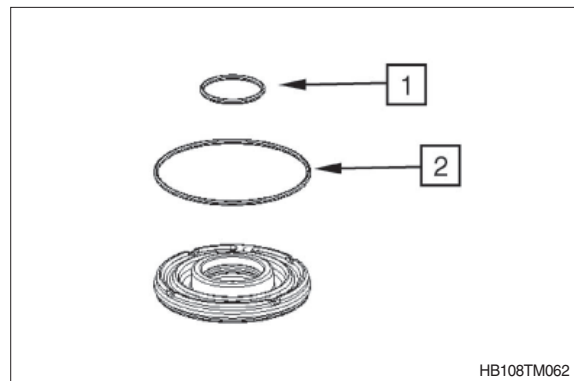

- ⑬ Snap out rectangular ring (1).

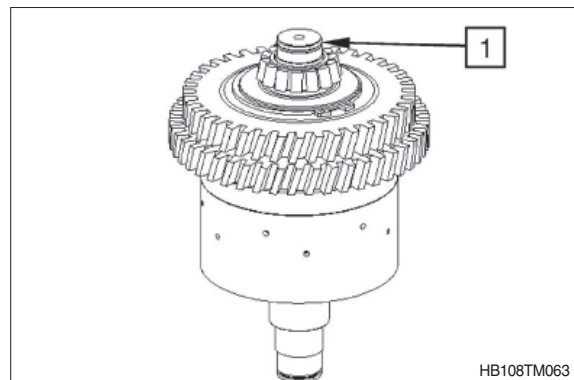

- ⑭ Pull tapered roller bearing (inner ring) off the shaft.

(S) Grab sleeve 5873 000 029
(S) Basic tool 5873 000 001

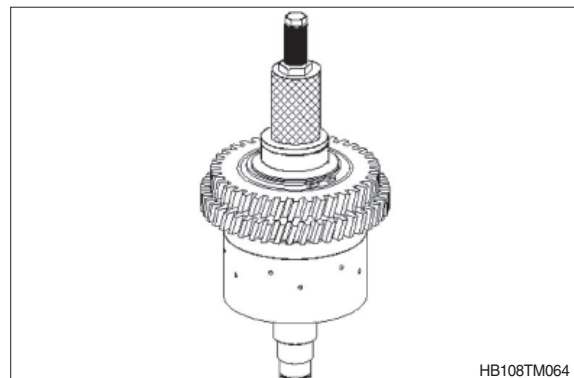

※ The clutch (1) cannot be disassembled.
It is supplied by the spare parts service only as a complete assembly which consists of:

- 1A = Retaining ring
- 1B = Helical gear
- 1C = Helical gear
- 1D = Disk carrier
- 1E = Shaft

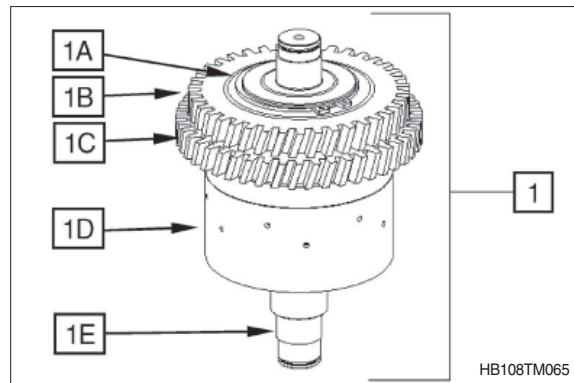

(3) K1 clutch

① Snap out rectangular ring (1).

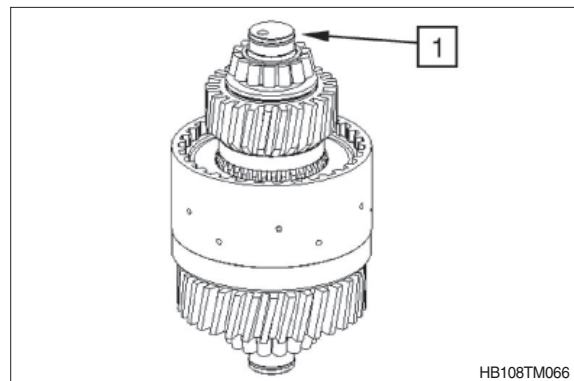

② Pull off bearing inner ring with inner disk carrier (1).

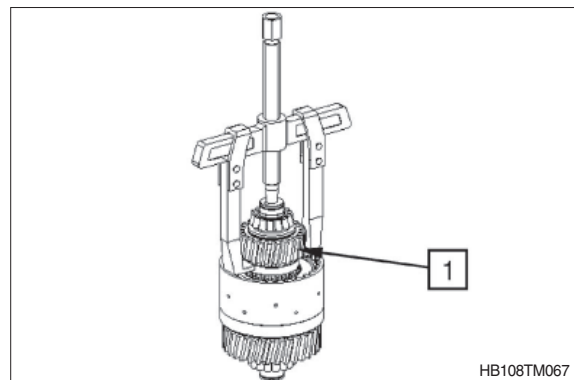

③ Remove bearing inner ring (1), axial bearing assembly (2), and inner disk carrier (3).

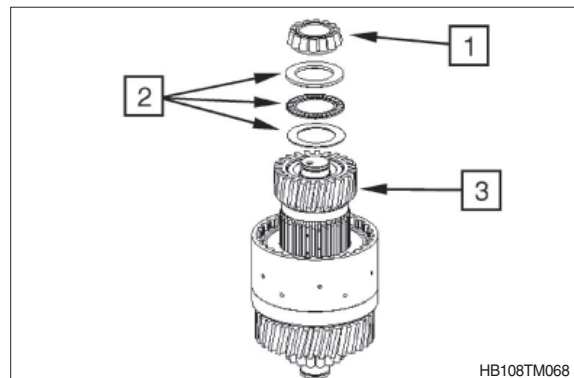

④ Remove needle cage (1).

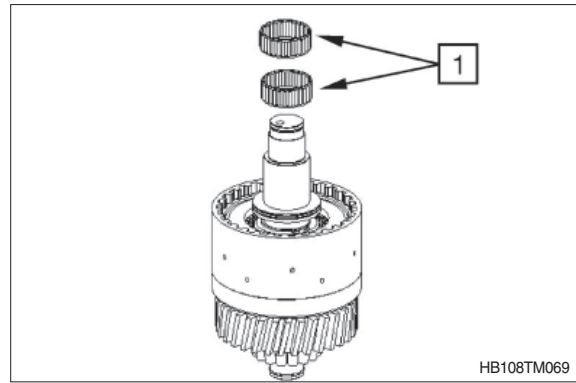

⑤ Remove axial bearing assy (1).

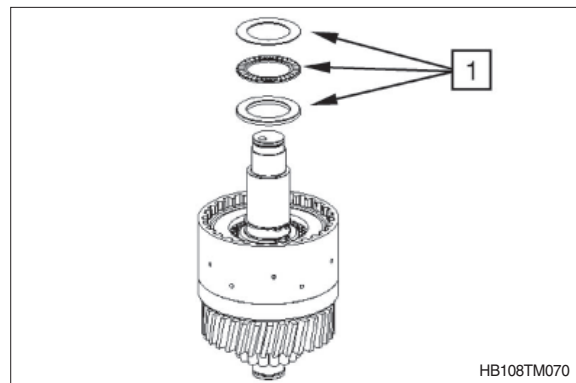

⑥ Remove snap ring (1).

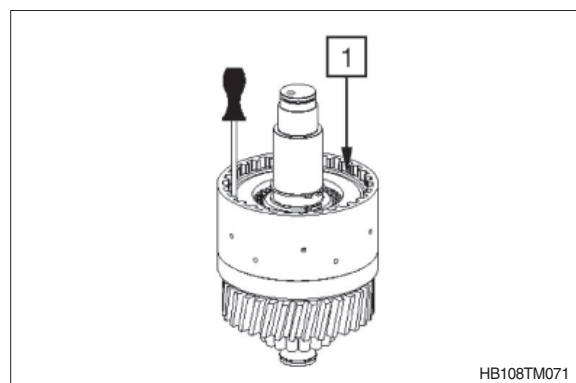

⑦ Remove end plate (1), disk package (2) and cup springs (3) from the disk carrier.

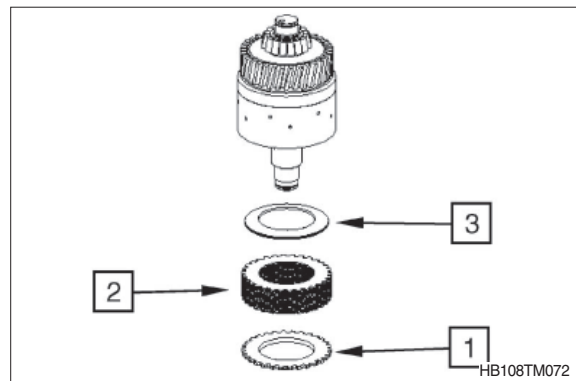

- ⑧ Remove retaining ring (1) at axial bearing contact.

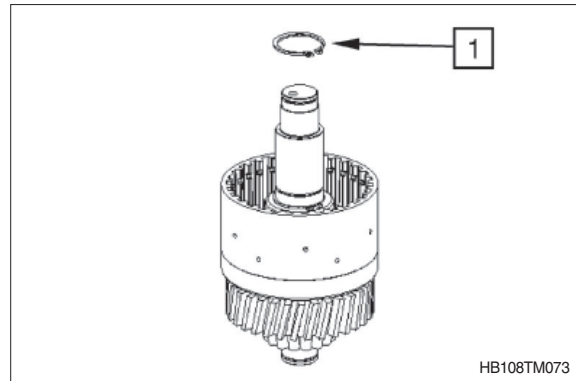

- ⑨ Preload compression spring and remove snap ring (1).

(S) Assembly aid 5870 345 114

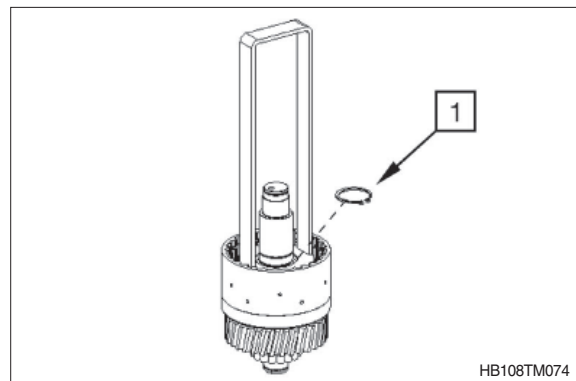

- ⑩ Remove spring cup (1) and compression spring (2).

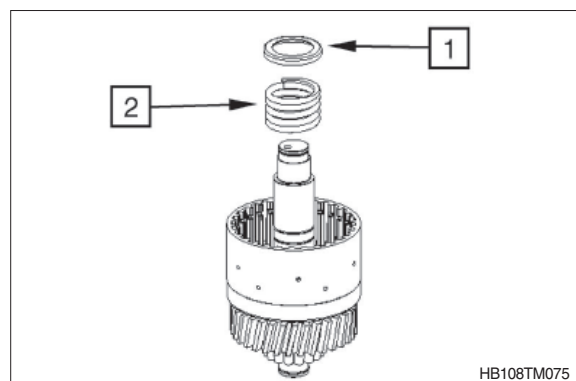

- ⑪ By means of compressed air (see arrow), press piston (1) off the shaft/disk carrier and remove it.

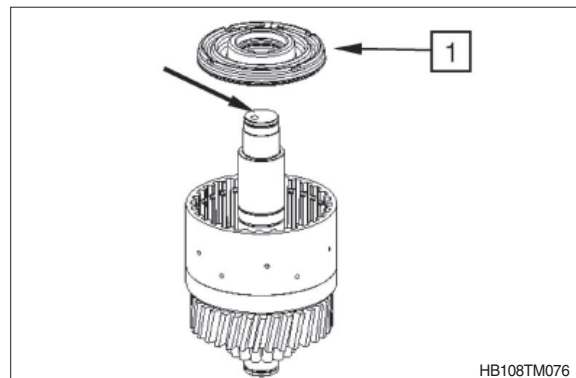

⑫ Remove both O-rings (1 and 2).

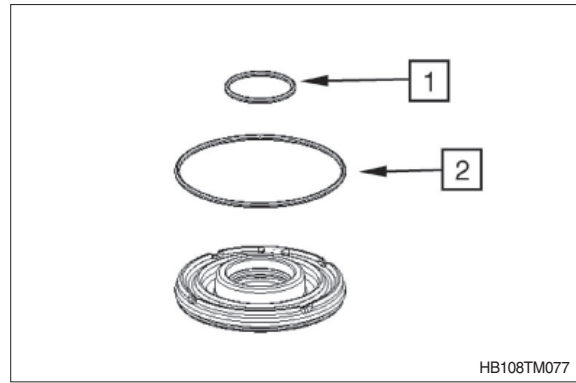

⑬ Snap out rectangular ring (1).

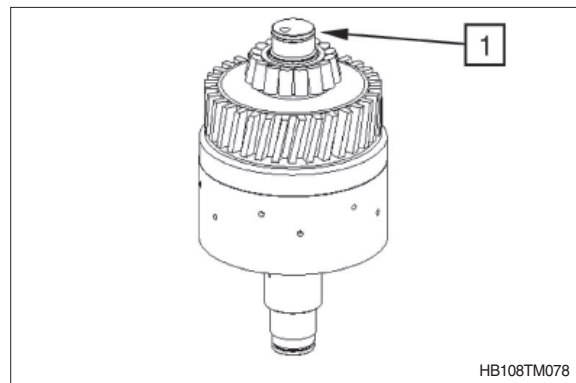

⑭ Pull tapered roller bearing (inner ring) off the shaft.

(S) Grab sleeve 5873 011 011
(S) Basic tool 5873 001 000

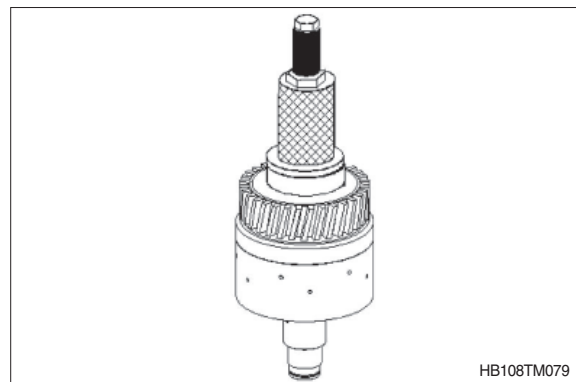

※ The clutch (1) cannot be disassembled.
It is supplied by the spare parts service
only as a complete assembly which consists
of:

1A = Helical gear
1B = Disk carrier
1C = Shaft

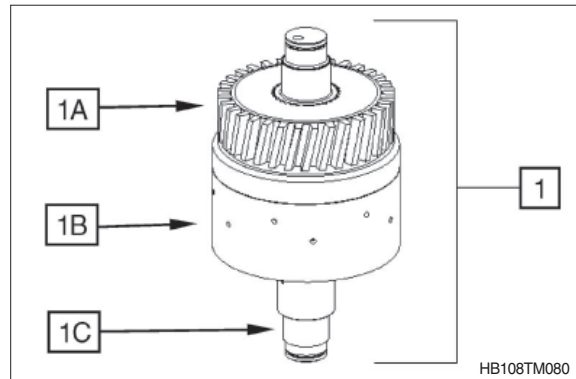

(4) K2 clutch

- ① Snap out rectangular ring (1).

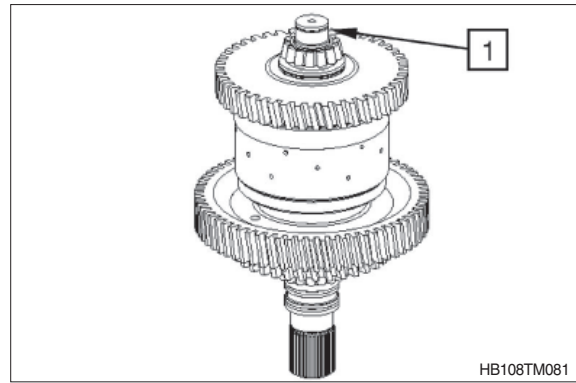

- ② Pull off bearing inner ring with inner disk carrier (1).

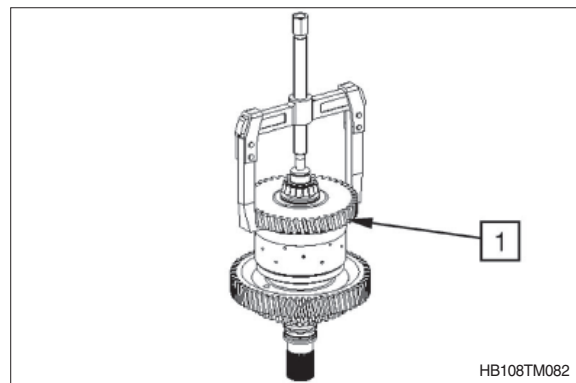

- ③ Remove bearing inner ring (1), axial bearing assy (2) and inner disk carrier (3).

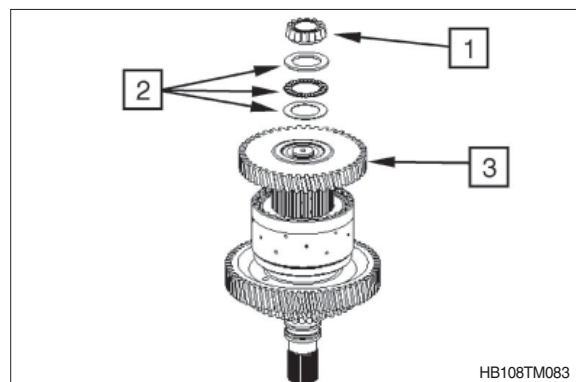

- ④ Remove needle cage (1) and bushing (2).

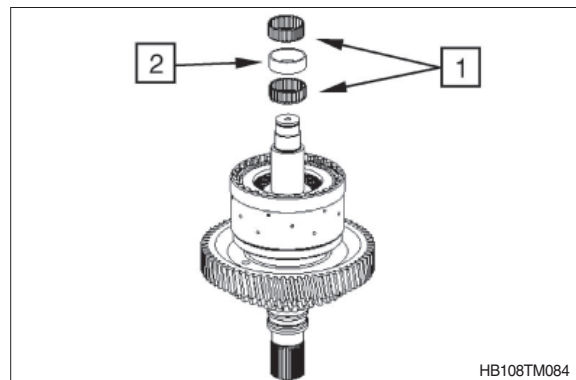

⑤ Remove axial bearing assy (1).

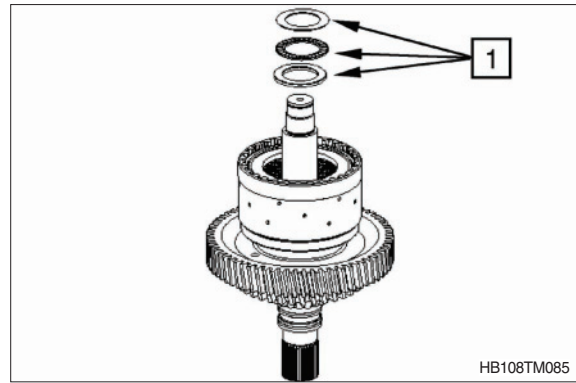

⑥ Remove snap ring (1).

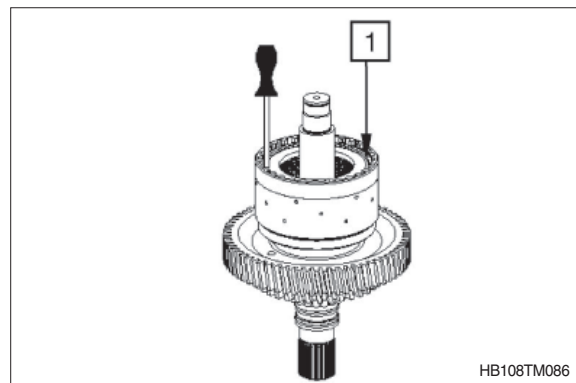

⑦ Remove end plate (1), disk package (2) and cup springs (3) from the disk carrier.

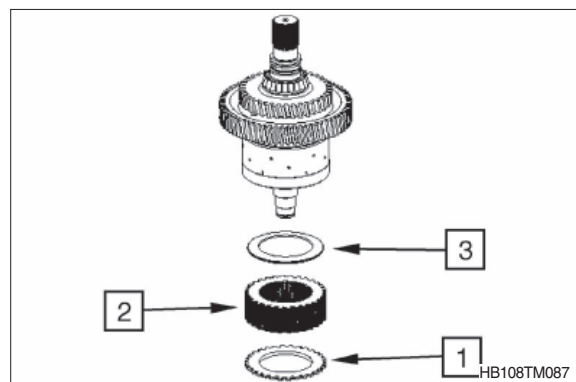

⑧ Remove retaining ring (1) at axial bearing contact.

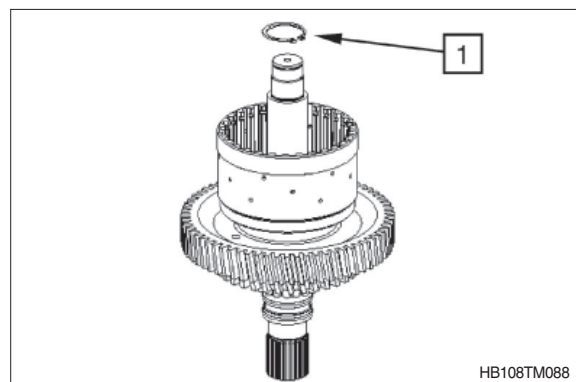

- ⑨ Preload cup springs and remove snap ring (1).

(S) Assembly aid 5870 345 114

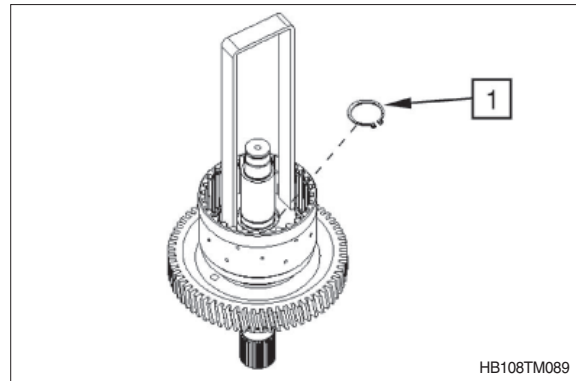

- ⑩ Remove axial washer (1) and cup springs (2).

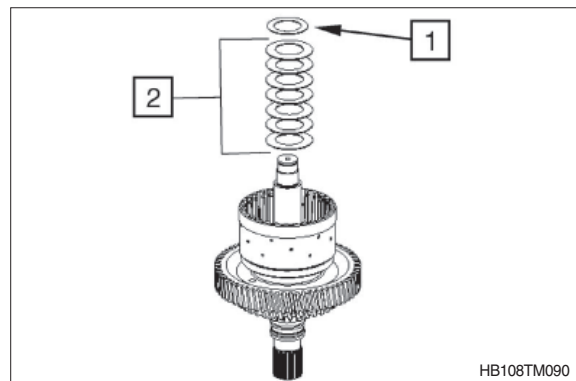

- ⑪ By means of compressed air (see arrow), press piston (1) off the shaft/disk carrier and remove it.

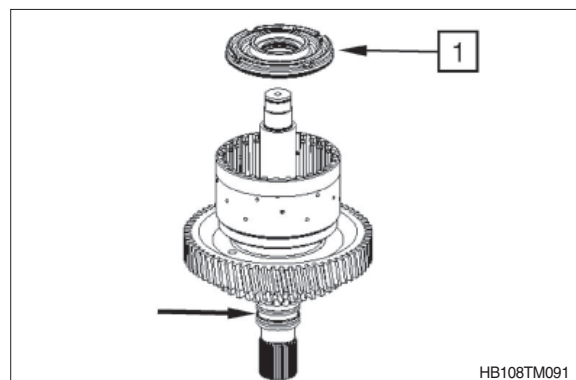

- ⑫ Remove both O-rings (1 and 2).

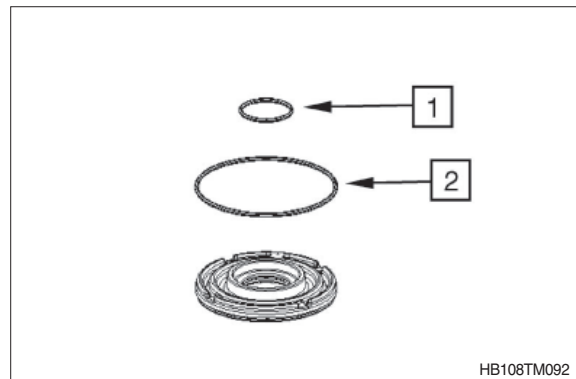

⑬ Snap out rectangular rings (1).

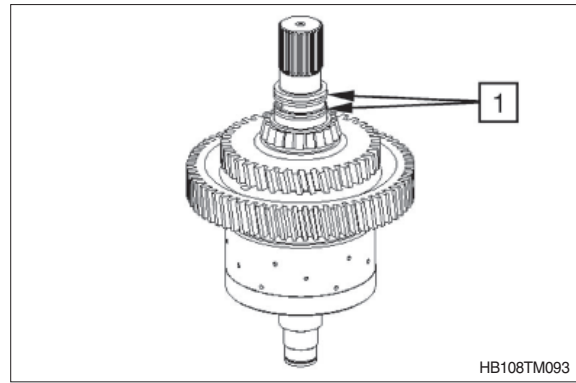

⑭ Pull tapered roller bearing (inner ring) off the shaft.

- (S) Grab sleeve 5873 001 026
- (S) Basic tool 5873 001 000

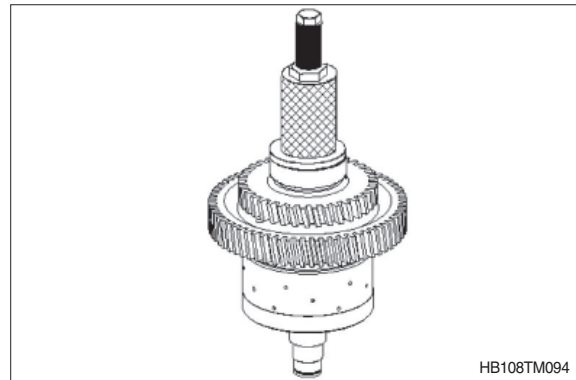

※ The clutch (1) cannot be disassembled.
It is supplied by the spare parts service
only as a complete assy which consists
of:

- 1A = Ball
- 1B = Helical gear
- 1C = Shaft
- 1D = Disk carrier

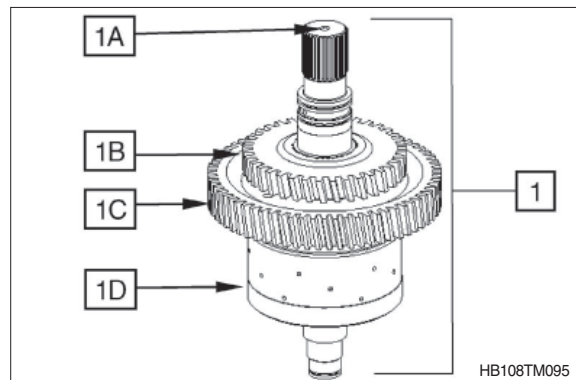

(5) K3 clutch

① Snap out rectangular ring (1).

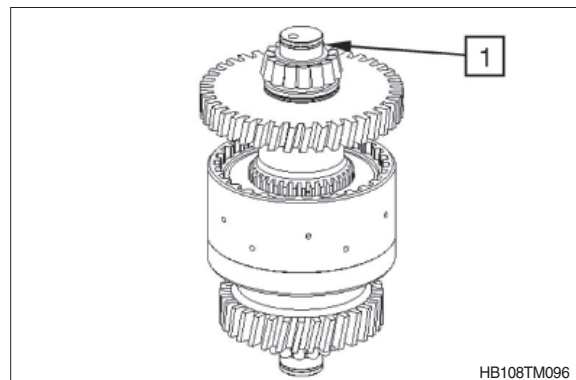

- ② Pull off bearing inner ring with inner disk carrier (1).

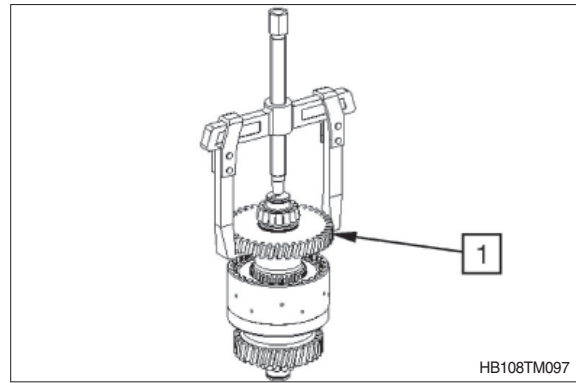

- ③ Remove bearing inner ring (1), axial bearing assy (2) and inner disk carrier (3).

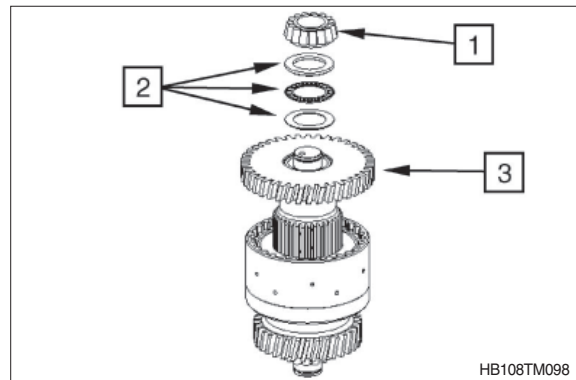

- ④ Remove needle cage (1) and bushing (2).

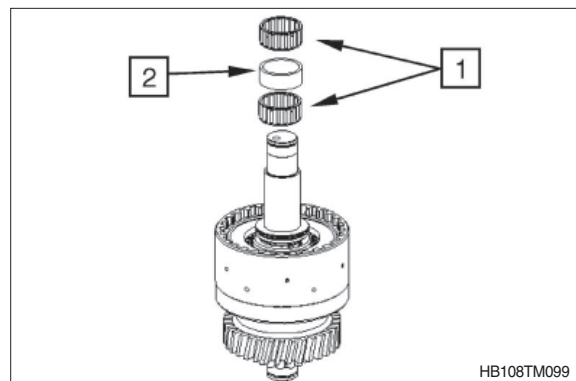

- ⑤ Remove axial bearing assy (1).

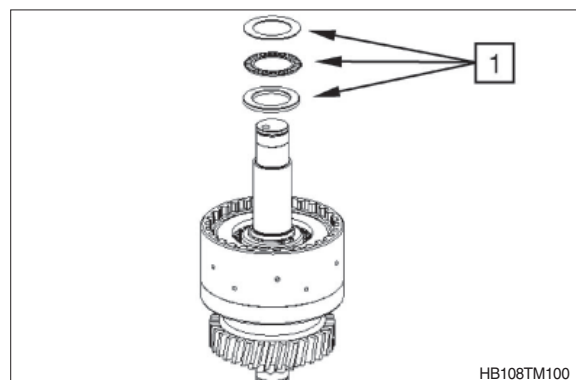

⑥ Remove snap ring (1).

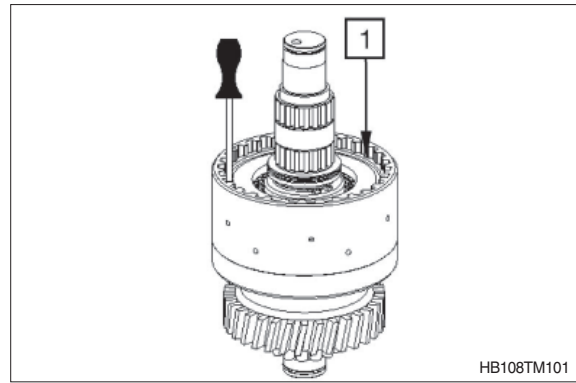

⑦ Remove end plate (1), disk package (2) and cup springs (3) from the disk carrier.

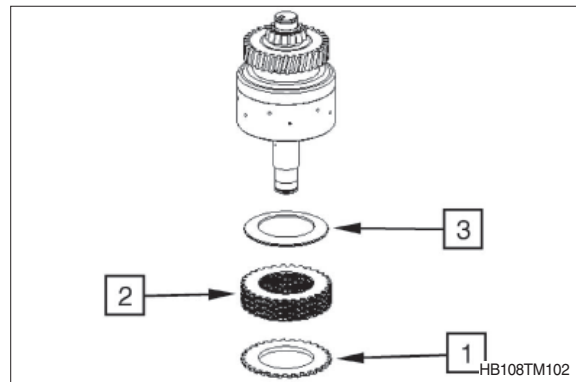

⑧ Preload compression spring and remove snap ring (1).

(S) Assembly aid 5870 345 114

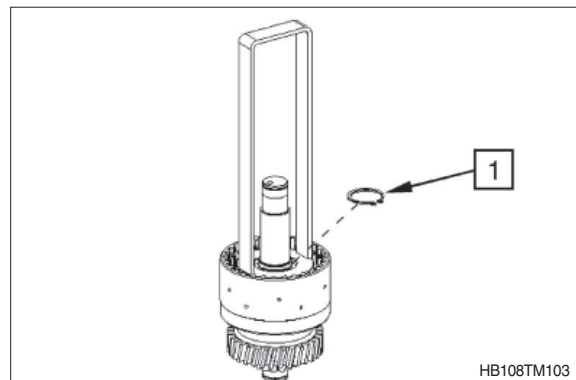

⑨ Remove spring cup (1) and compression spring (2).

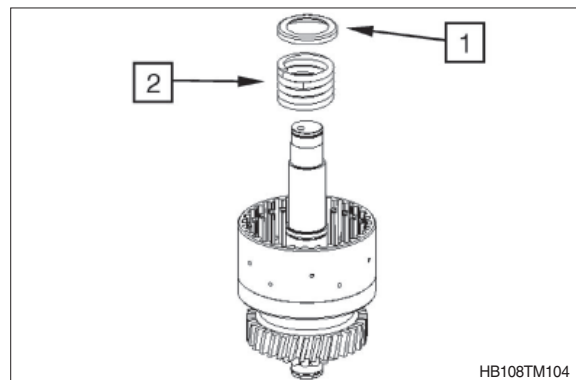

- ⑩ By means of compressed air (see arrow), press piston (1) off the shaft/disk carrier and remove it.

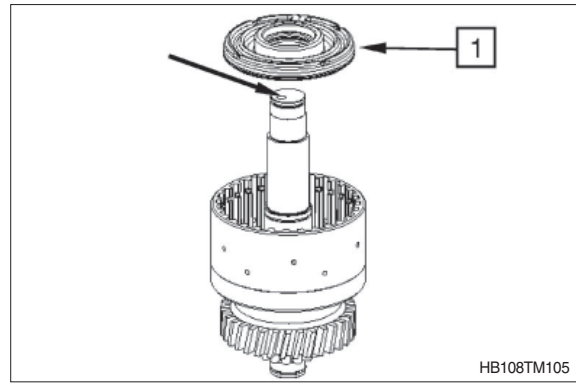

- ⑪ Remove both O-rings (1 and 2).

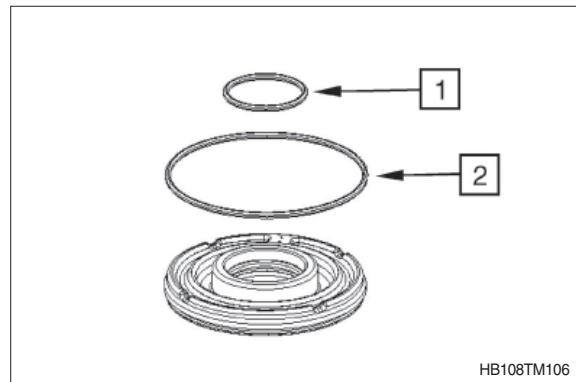

- ⑫ Snap out rectangular ring (1).

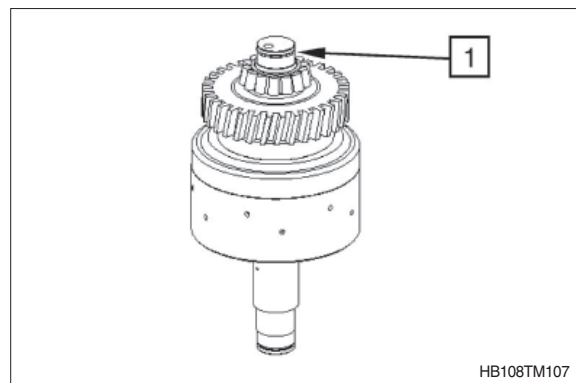

- ⑬ Pull tapered roller bearing (inner ring) off the shaft.

(S) Grab sleeve 5873 000 029
(S) Basic tool 5873 000 001

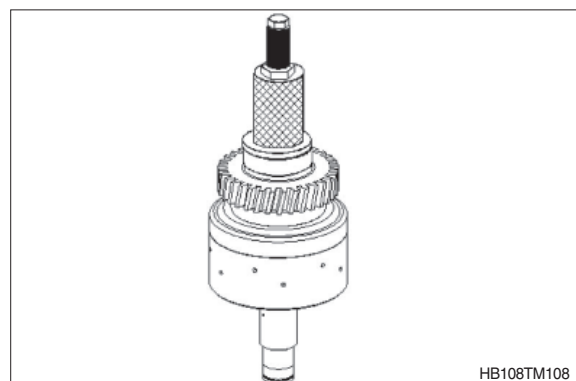

※ The clutch (1) cannot be disassembled.
It is supplied by the spare parts service
only as a complete assy which consists
of:

1A = Helical gear

1B = Shaft

1C = Disk carrier

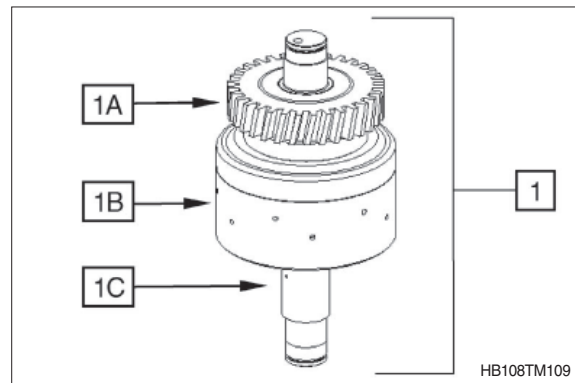

(6) K4 clutch

① Snap out rectangular ring (1).

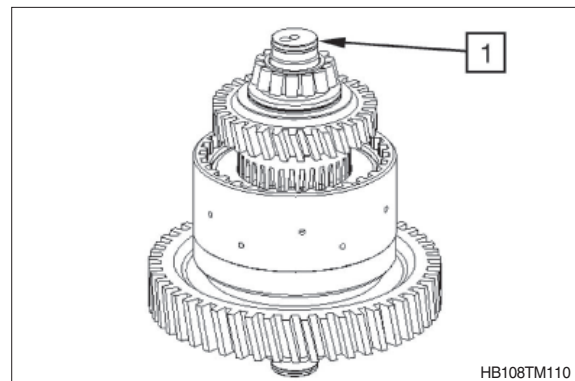

② Pull off bearing inner ring with inner
disk carrier (1).

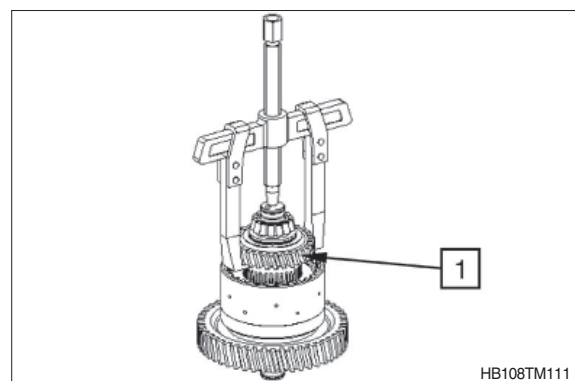

③ Remove bearing inner ring (1), axial
bearing assy (2) and inner disk carrier
(3).

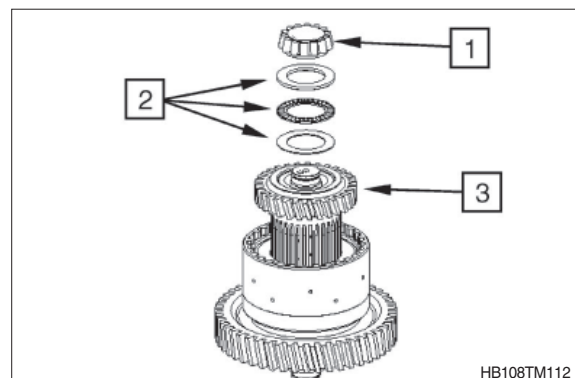

④ Remove needle cage (1).

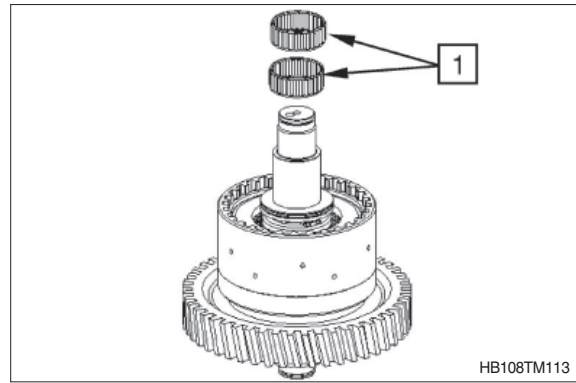

⑤ Remove axial bearing assy (1).

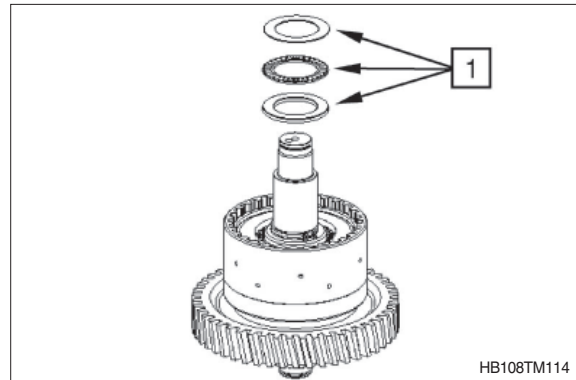

⑥ Remove snap ring (1).

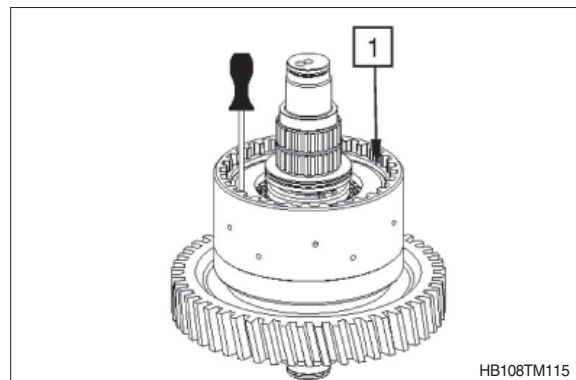

⑦ Remove end plate (1), disk package (2) and plate assy with cup springs (3) from the disk carrier.

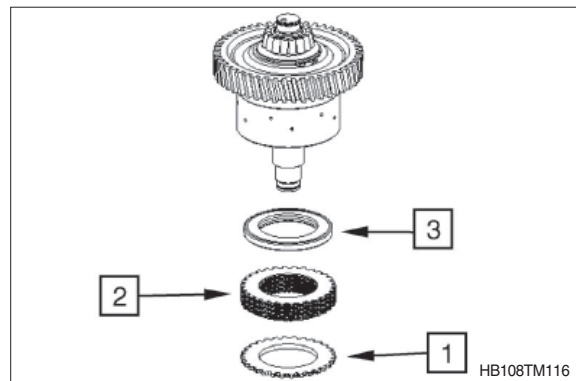

- ⑧ Remove retaining ring (1) at axial bearing contact.

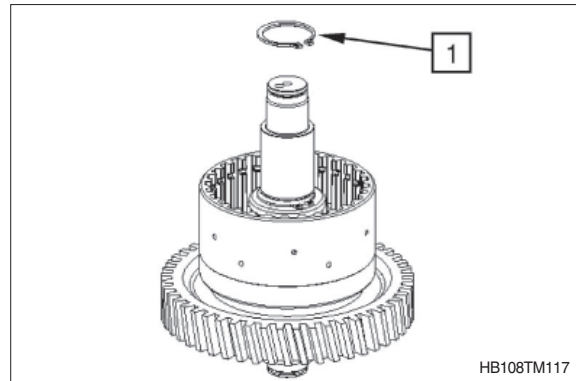

- ⑨ Preload compression spring and remove snap ring (1).
(S) Assembly aid 5870 345 114

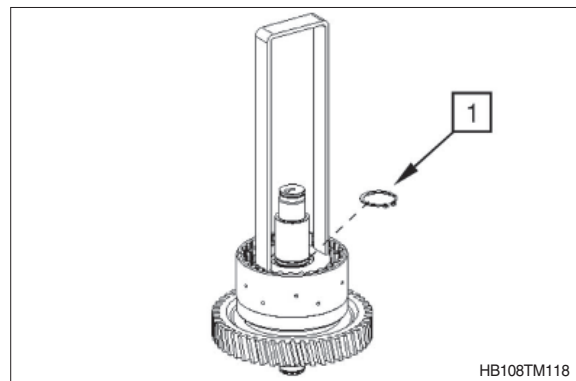

- ⑩ Remove spring cup (1) and compression spring (2).

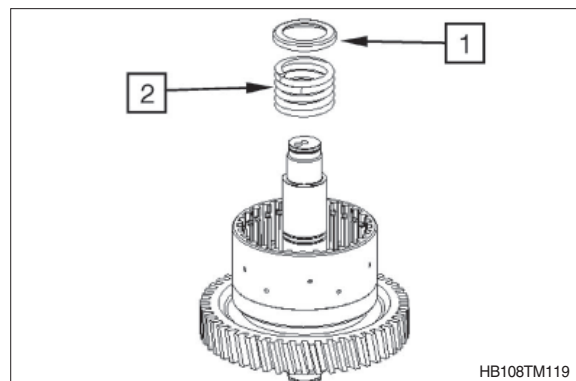

- ⑪ By means of compressed air (see arrow), press piston (1) off the shaft/disk carrier and remove it.

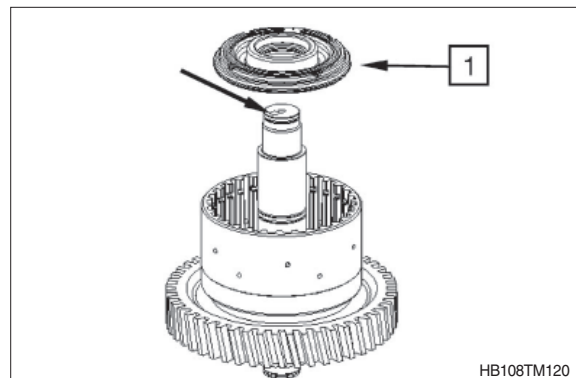

⑫ Remove both O-rings (1 and 2).

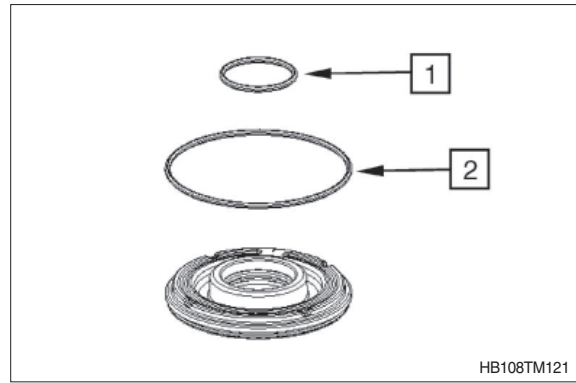

⑬ Snap out rectangular ring (1).

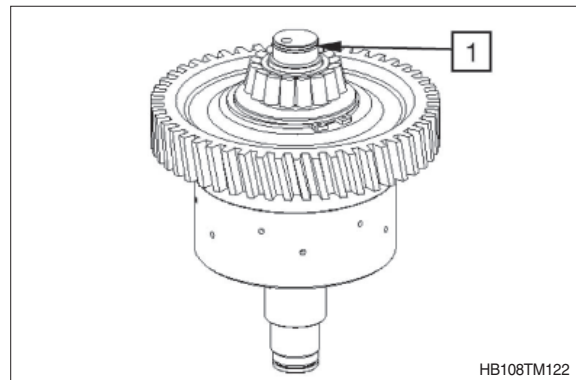

⑭ Pull tapered roller bearing (inner ring) off the shaft.

(S) Grab sleeve 5873 011 011
(S) Basic tool 5873 001 000

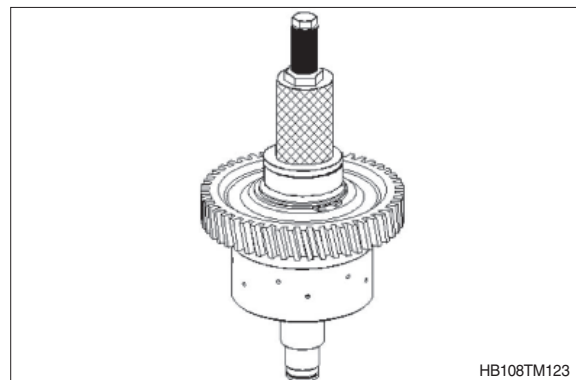

※ The clutch (1) cannot be disassembled.
It is supplied by the spare parts service only as a complete assy which consists of:

1A = Retaining ring
1B = Helical gear
1C = Disk carrier
1D = Shaft

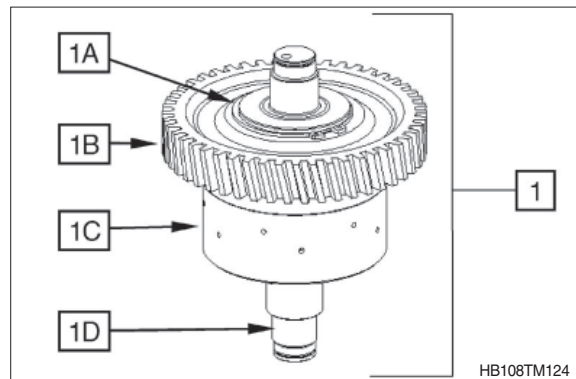

(7) Front wheel drive (VA)

- ① Snap out rectangular ring (1).

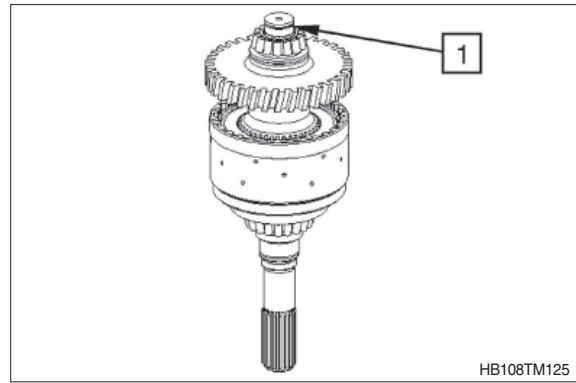

- ② Pull tapered roller bearing (inner ring) off the shaft.

(S) Grab sleeve 5873 000 029
(S) Basic tool 5873 000 001

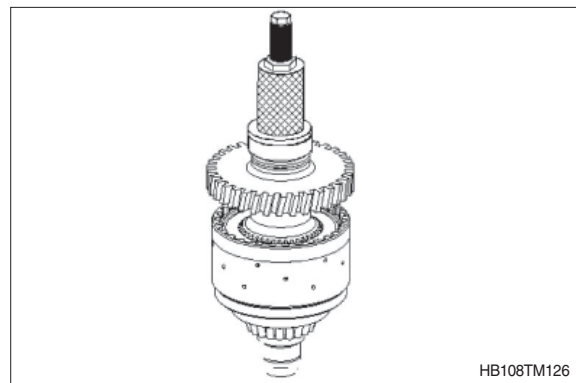

- ③ Remove running disk (1).

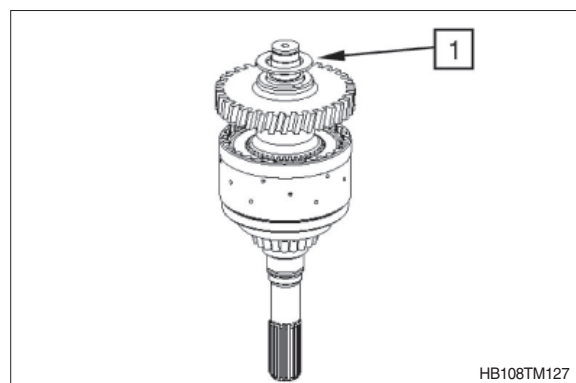

- ④ Pull off inner disk carrier (1).

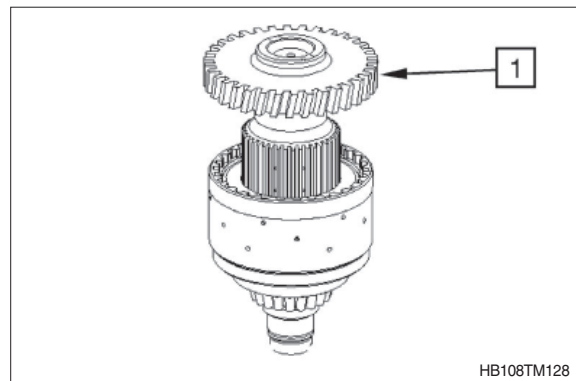

⑤ Remove snap ring (1).

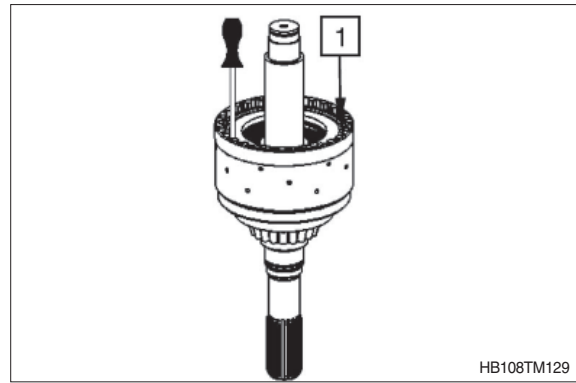

⑥ Remove end plate (1) and disk package (2) from the disk carrier.

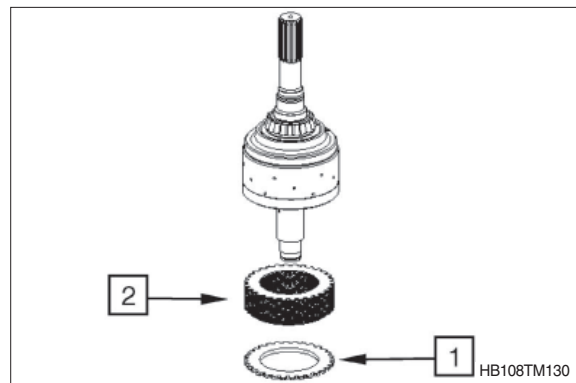

⑦ Preload cup springs and remove snap ring (1).

(S) Assembly aid 5870 506 128

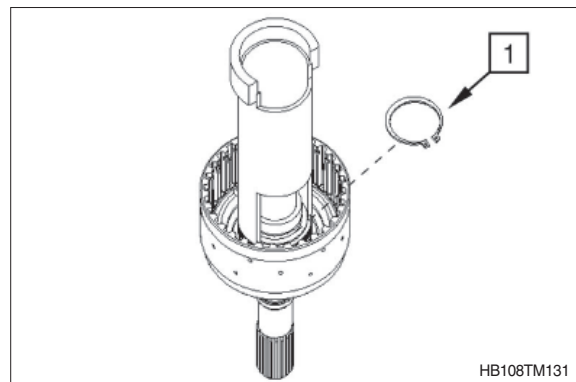

⑧ Remove washer (1) and cup springs (2).

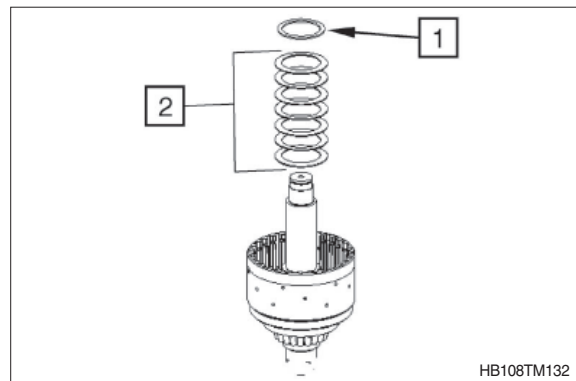

- ⑨ By means of compressed air (see arrow), press piston (1) off the shaft/disk carrier and remove it.

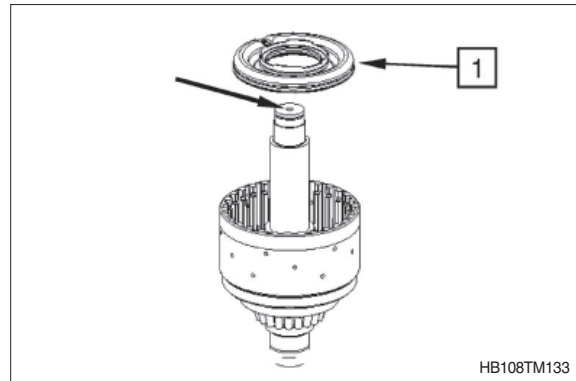

- ⑩ Pull tapered roller bearing (inner ring) off the shaft.

(S) Grab sleeve 5873 001 026
 (S) Basic tool 5873 001 000

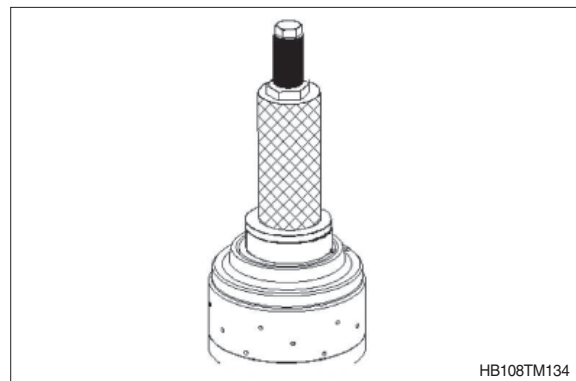

- ※ The clutch (1) cannot be disassembled.
 It is supplied by the spare parts service only as a complete assy which consists of:

1A = Shaft
 1B = Disk carrier

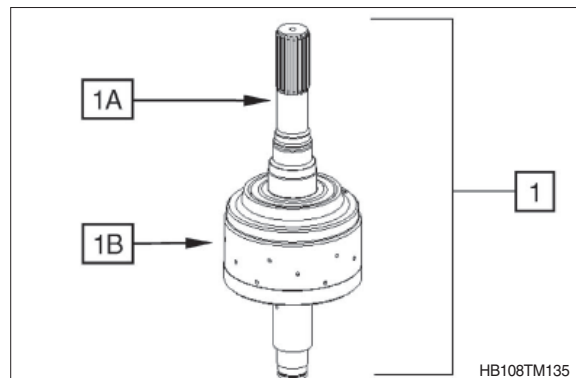

5) REASSEMBLY OF CLUTCHES

(1) KR clutch / input

※ The input shaft (1) is supplied by the spare parts service only as a complete assy which consists of:

1A = Ball

1B = Helical gear

1C = Disk carrier

1D = Input shaft

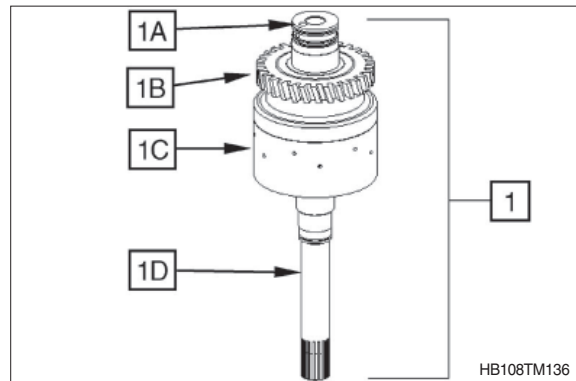

① Heat up bearing inner ring (approx. 120°C).

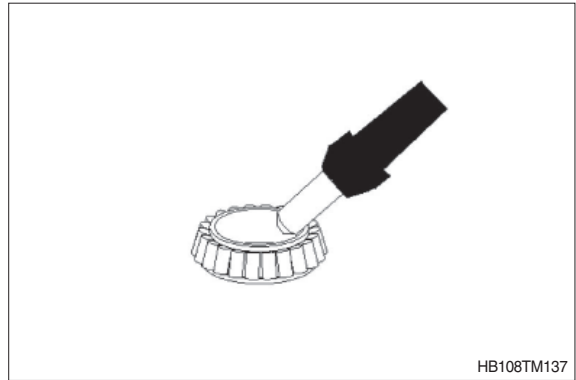

② Mount bearing inner ring (1) until contact is obtained.

Fit rectangular rings 50×2.5 (2).

Wear protective gloves.

※ Adjust bearing inner ring after cooling-down.

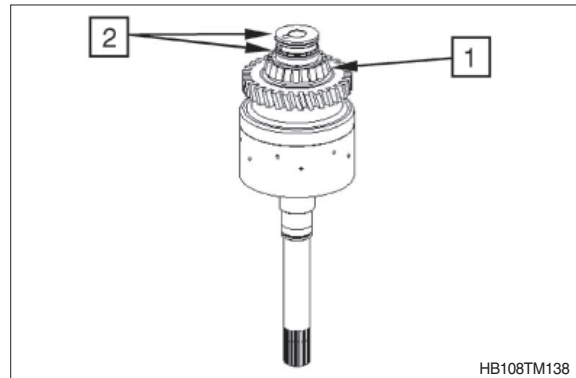

③ Insert both O-rings (1 and 2) into the piston grooves and oil them.

1 = 40×3

2 = 104.5×3

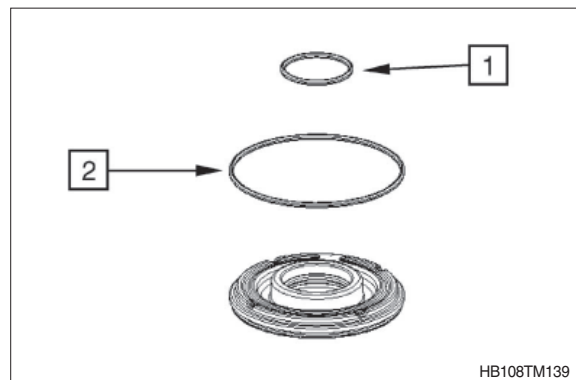

④ Insert piston (1) into the disk carrier.

※ Pay attention to the installation position, see figure.

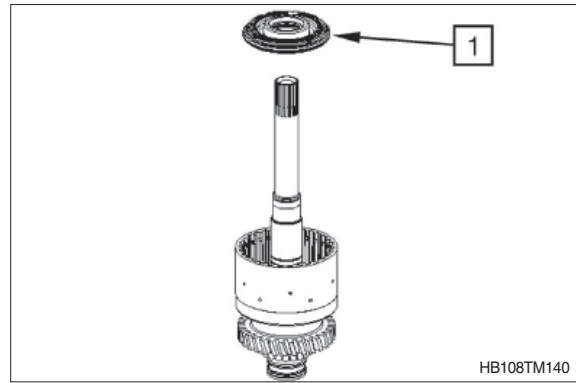

⑤ Use a hand-operated press to place piston into the disk carrier by means of the assembly aid.

(S) Assembly aid 5870 345 114

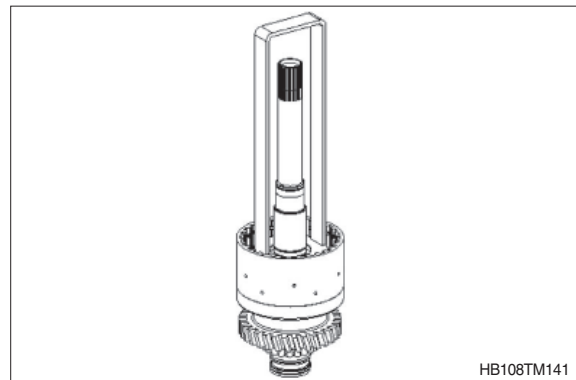

⑥ Mount compression spring (1) and spring cup (2).

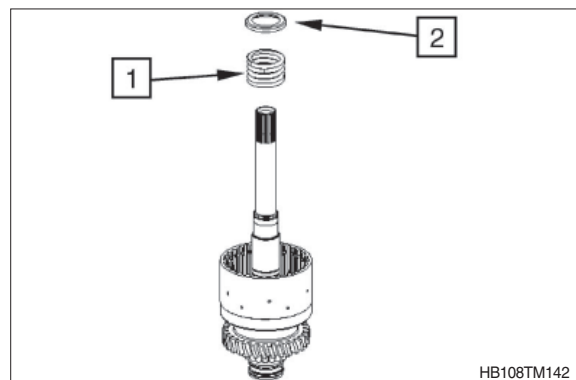

⑦ By means of the assembly aid, preload compression spring under a hand-operated press until the retaining ring 40×1.75 (1) can be snapped in.

(S) Assembly aid 5870 345 114

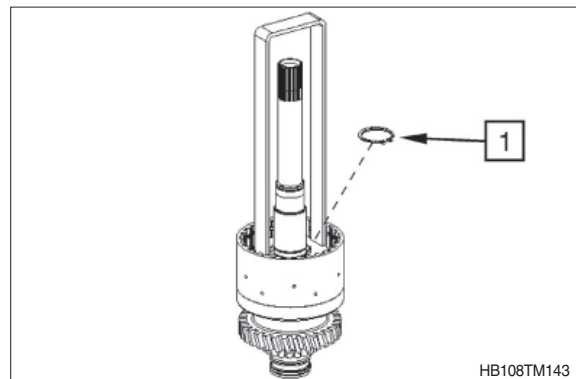

- ⑧ Mount plate assy with cup springs (1), with the open side showing towards the piston.

※ Installation position of plate see also the next figure ⑨.

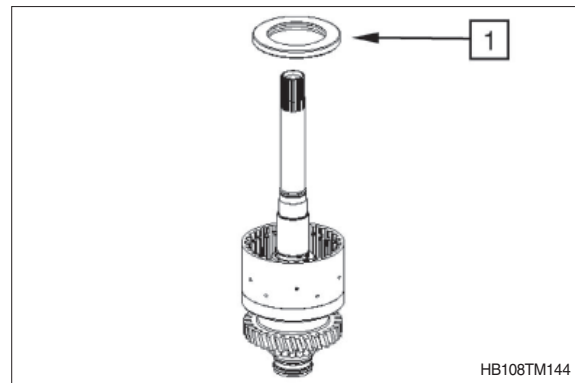

- ⑨ Fit plate (1) according to sketch (see arrow).

Legend:

- 1 = Plate assy with cup springs
- 2 = Compression spring with spring cup and retaining ring
- 3 = Piston with O-rings
- 4 = Input shaft assy

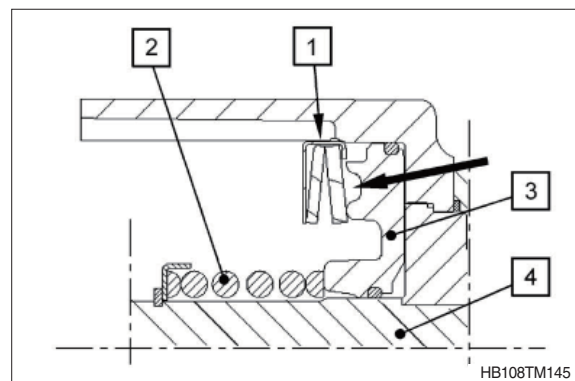

- ⑩ Install outer and inner disks alternately into the disk carrier (3) as shown in the right figure, starting with an outer disk and ending with an inner disk.

Legend:

- 1 = Outer disks (10 pcs)
- 2 = Inner disks (10 pcs)
- 3 = Input shaft assy

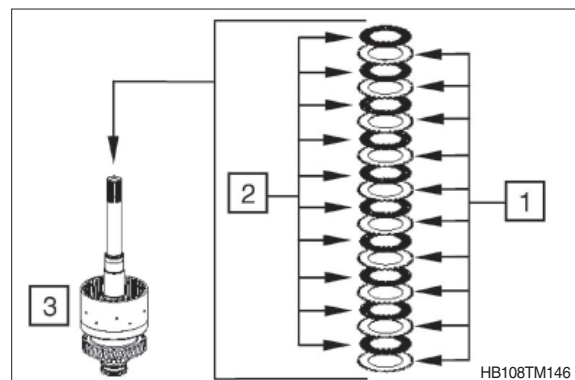

- ⑪ Mount end plate (1) with the flat side showing towards the disk package and fix it by means of snap ring (2) (e.g. thickness = 2.5 mm / recommended value).

※ Pay attention to the installation position of the end plate.

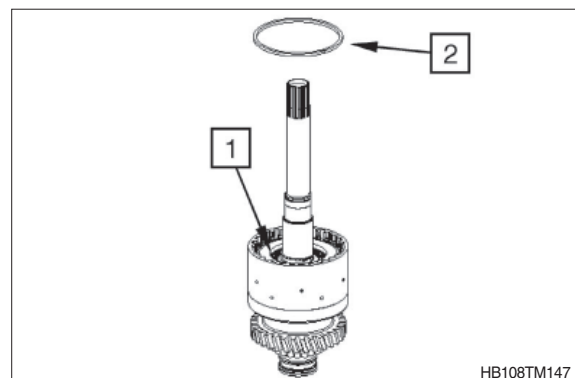

- ⑫ Equally press on end plate with F (approx 1.8 kg to 2.0 kg) and set dial indicator to "zero".

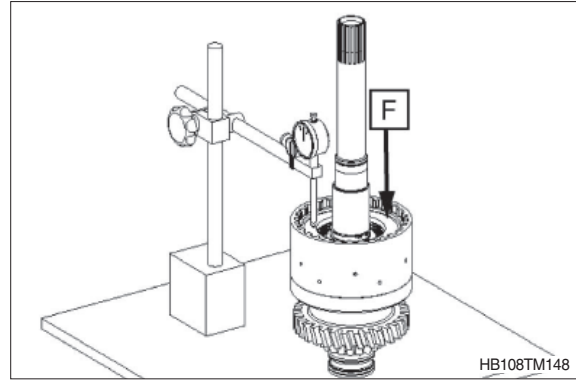

- ⑬ Then press end plate against the snap ring (upwards) and read the disk clearance.

- ※ Disk clearance: 2.0 to 2.3 mm
- ※ In case of deviations, the disk clearance must be corrected with an appropriate snap ring (optional thickness = 2.0 ~ 3.5 mm / available in steps of 0.25 mm)

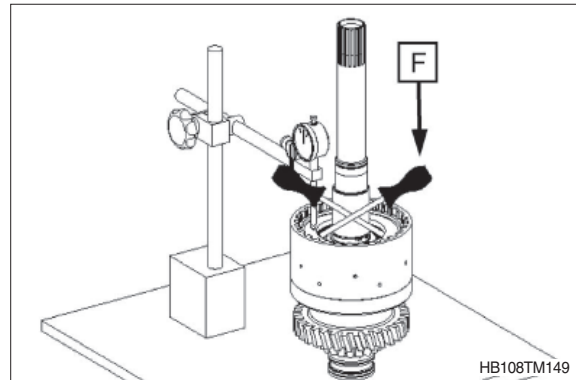

- ⑭ Snap retaining ring 40×1.75 (1) into the groove.

- ※ Contact for axial bearing - see figure ⑮.

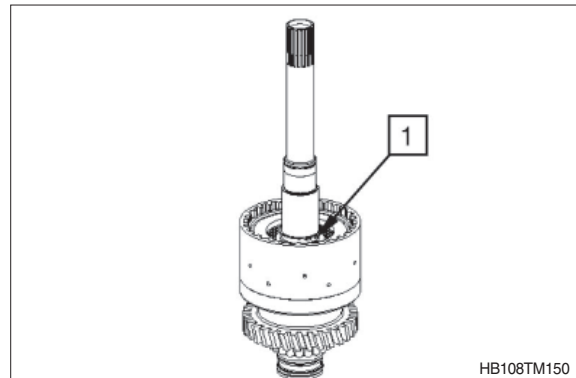

- ⑮ Mount running disk $40 \times 60 \times 3.5$ (1), axial needle cage $40 \times 60 \times 3$ (2) and axial washer $40 \times 60 \times 1$ (3) and oil them.

- ※ Mount running disk (1), with the chamfer showing towards the retaining ring.

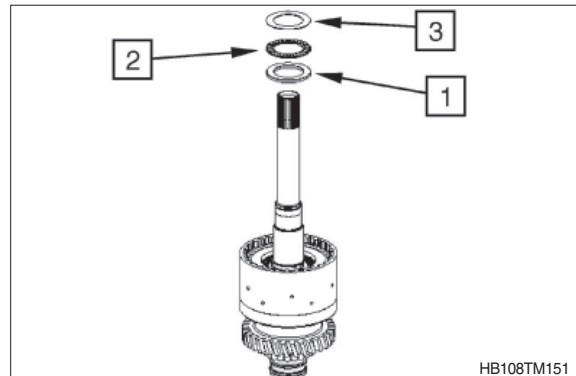

- ⑩ Mount needle cage $40 \times 45 \times 17$ (1) and oil it.

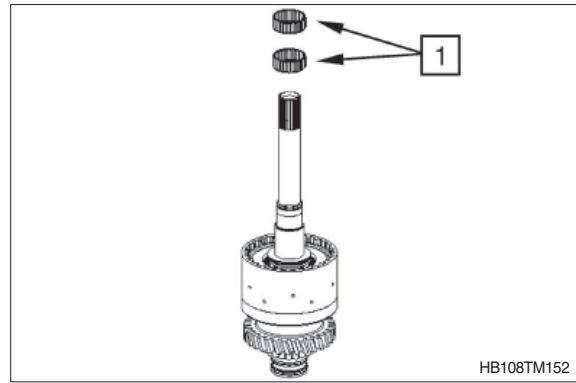

- ⑪ Mount inner disk carrier until contact is obtained.
⑫ Install inner disks by short ccw/cw rotations of the inner disk carrier (1).

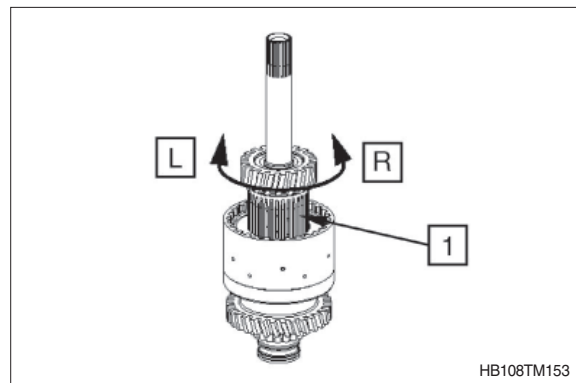

- ⑬ Mount axial washer $40 \times 60 \times 1$ (1), axial needle cage $40 \times 60 \times 3$ (2) and running disk (3) $40 \times 60 \times 3.5$ and oil them.

- ※ Mount running disk (3), with the chamfer showing towards the tapered roller bearing.

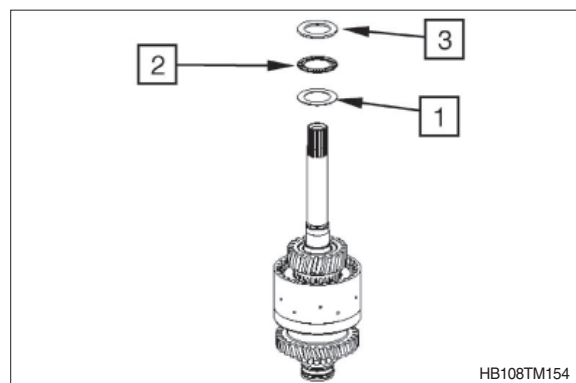

- ⑭ Heat up bearing inner ring (approx. 120°C).

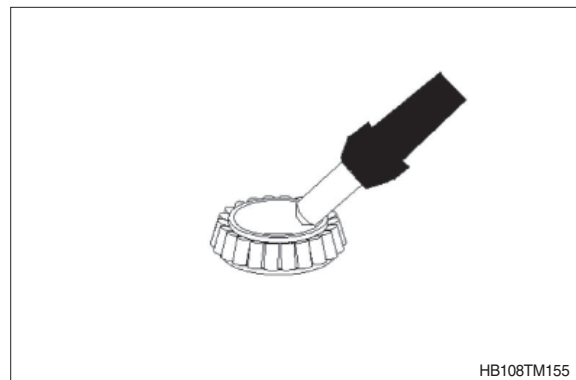

- ① Mount bearing inner ring (1) until contact is obtained.
- ② Fit rectangular ring 30 × 2 (2).

Wear protective gloves.

- ※ Adjust bearing inner ring after cooling-down.

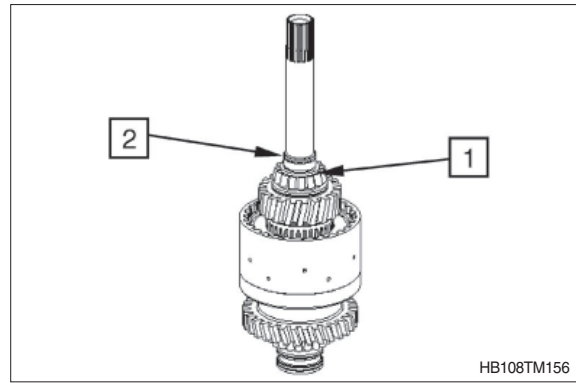

- ※ Check closing and opening of the clutch by means of compressed air at the hole (see arrow). Closing and opening of the clutch must be clearly audible.

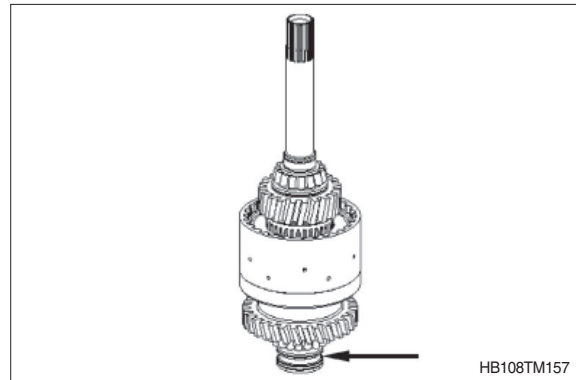

(2) KV clutch

- ※ The clutch (1) is supplied by the spare parts service only as a complete assy which consists of:

- 1A = Retaining ring
- 1B = Helical gear
- 1C = Helical gear
- 1D = Disk carrier
- 1E = Shaft

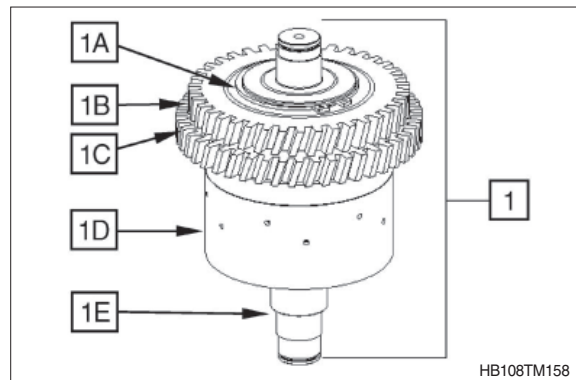

- ① Heat up bearing inner ring (approx. 120°C).

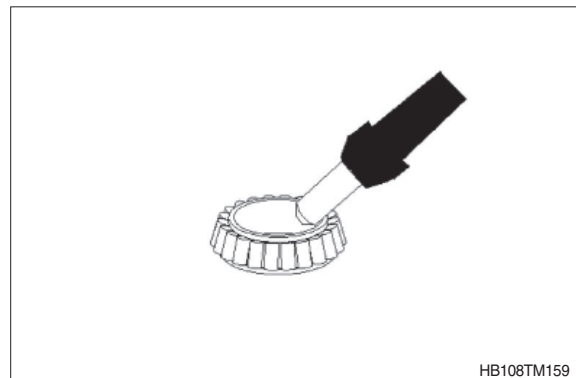

- ② Mount bearing inner ring (1) until contact is obtained.
- ③ Fit rectangular ring 30 × 2 (2).

Wear protective gloves.

- ※ Adjust bearing inner ring after cooling-down.

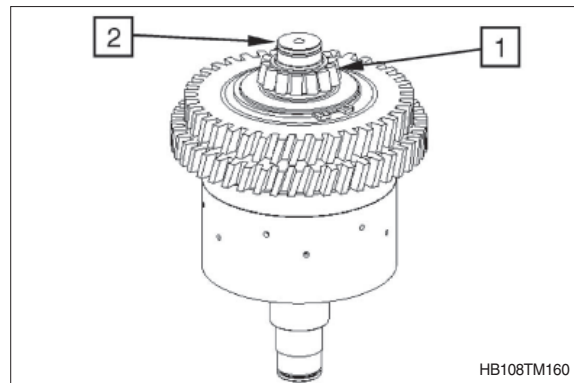

- ④ Insert both O-rings (1 and 2) into the piston grooves and oil them.

1 = 40 × 3

2 = 104.5 × 3

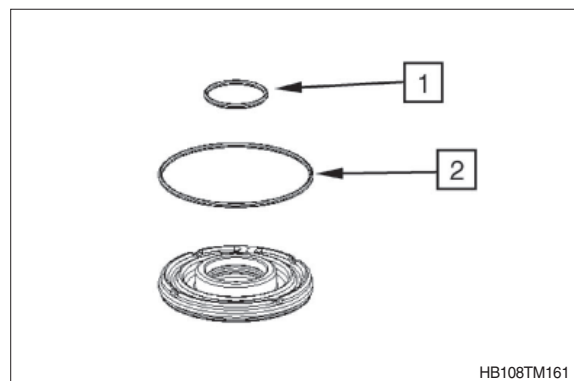

- ⑤ Insert piston (1) into the disk carrier.

- ※ Pay attention to the installation position, see figure.

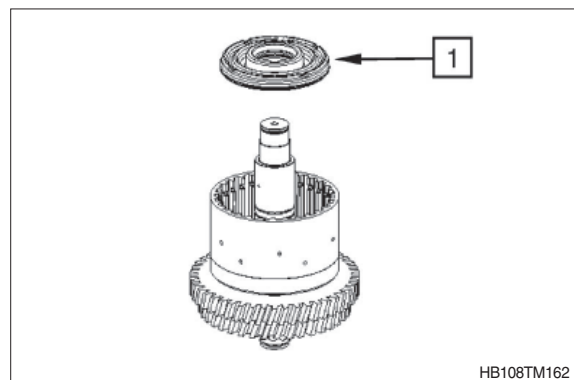

- ⑥ Use a hand-operated press to place piston into the disk carrier by means of the assembly aid.

(S) Assembly aid

5870 345 114

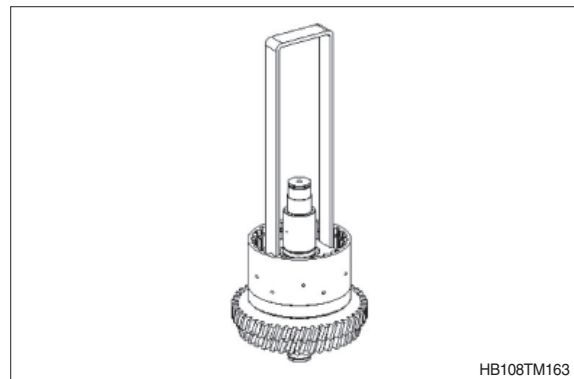

- ⑦ Mount compression spring (1) and spring cup (2).

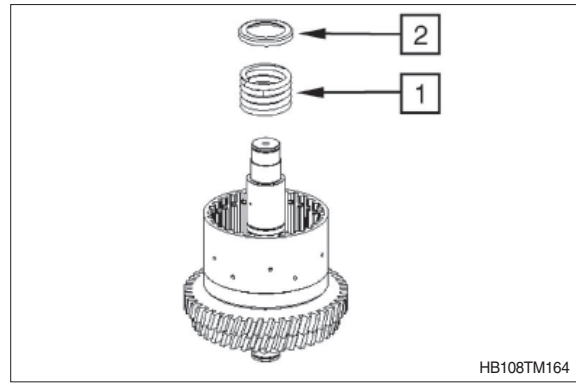

- ⑧ By means of the assembly aid, preload compression spring under a hand-operated press until the retaining ring 40×1.75 (1) can be snapped in.

(S) Assembly aid 5870 345 114

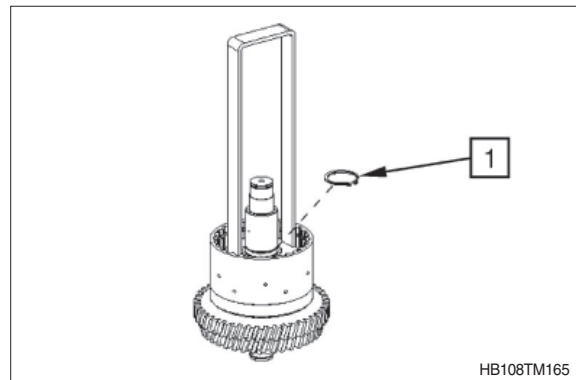

- ⑨ Mount plate assy with cup springs (1), with the open side showing towards the piston.

※ Installation position of plate see also figure ⑩.

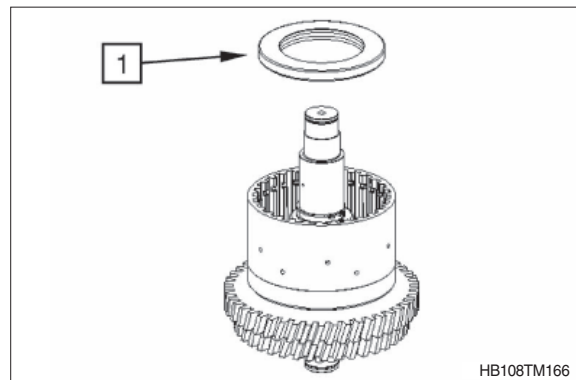

- ⑩ Fit plate (1) according to sketch (see arrow).

Legend:

- 1 = Plate assy with cup springs
- 2 = Compression spring with spring cup and retaining ring
- 3 = Piston with O-rings
- 4 = Input shaft assy

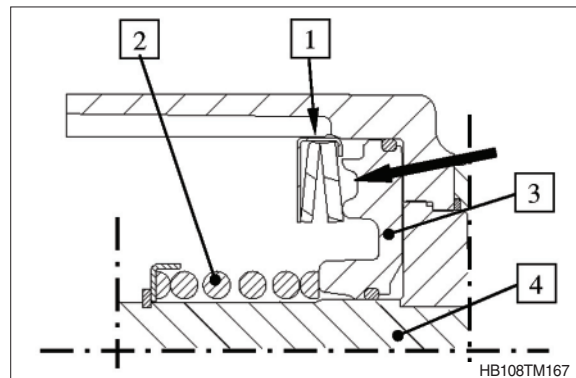

- ⑪ Install outer and inner disks alternately into the disk carrier (3) as shown in figure, starting with an outer disk and ending with an inner disk.

Legend:

- 1 = Outer disks (10 pcs)
- 2 = Inner disks (10 pcs)
- 3 = Clutch assy

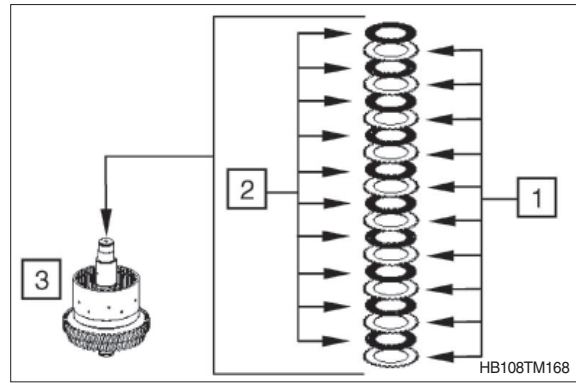

- ⑫ Mount end plate (1) with the flat side showing towards the disk package and fix it by means of snap ring (2) (e.g. thickness = 2.5 mm / recommended value).

- ※ Pay attention to the installation position of the end plate.

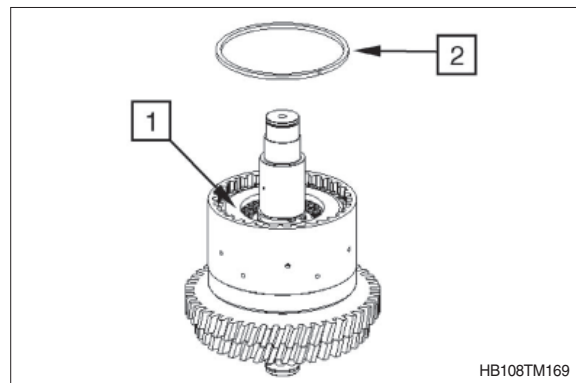

- ⑬ Equally press on end plate with F (approx. 1.8 kg to 2.0 kg) and set dial indicator to "zero".

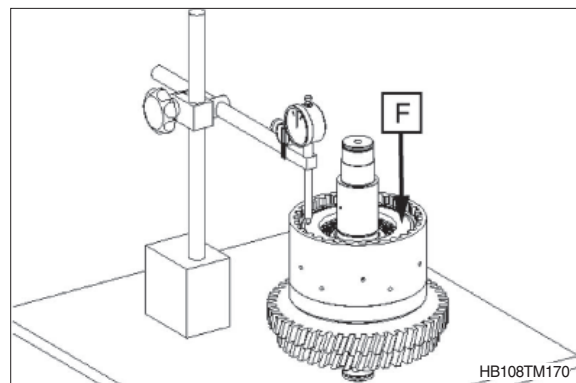

- ⑭ Then press end plate against the snap ring (upwards) and read the disk clearance.

- ※ Disk clearance: 2.0 to 2.3 mm
- ※ In case of deviations, the disk clearance must be corrected with an appropriate snap ring (optional thickness = 2.0 ~ 3.5 mm / available in steps of 0.25 mm)

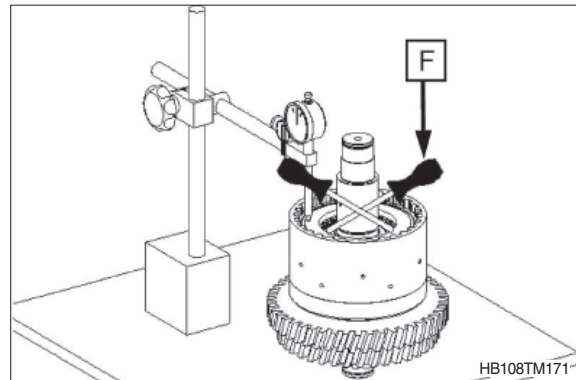

⑮ Snap retaining ring 40×1.75 (1) into the groove.

※ Contact for axial bearing - see the next figure ⑯.

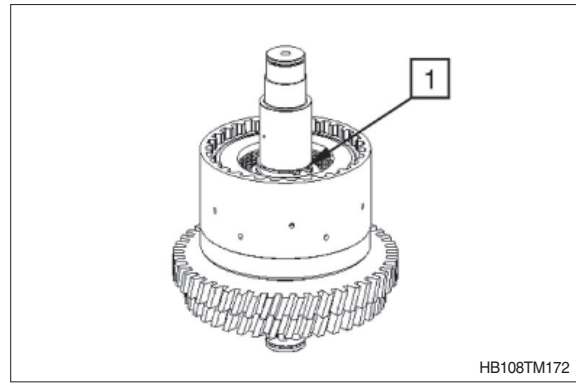

⑯ Mount running disk $40 \times 60 \times 3.5$ (1), axial needle cage $40 \times 60 \times 3$ (2) and axial washer $40 \times 60 \times 1$ (3) and oil them.

※ Mount running disk (1), with the chamfer showing towards the retaining ring.

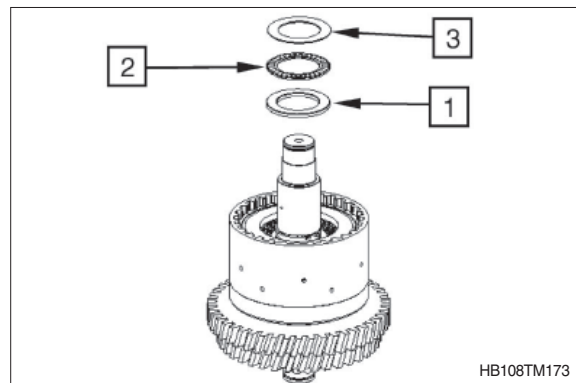

⑰ Mount needle cage $40 \times 45 \times 17$ (1) and oil it.

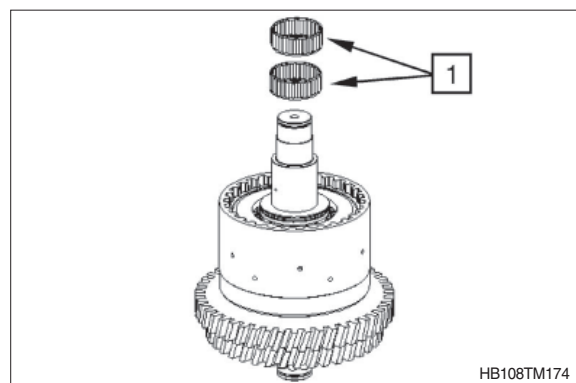

⑱ Mount inner disk carrier until contact is obtained.

⑲ Install inner disks by short ccw/cw rotations of the inner disk carrier (1).

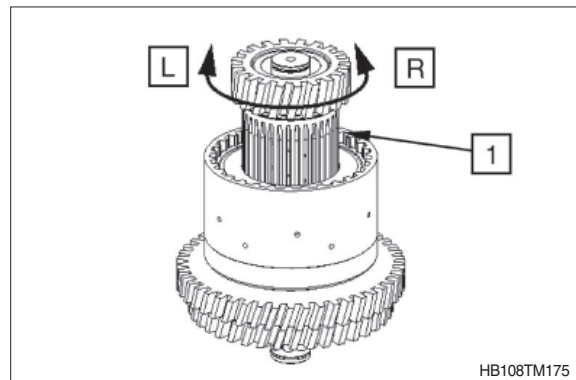

⑳ Mount axial washer $40 \times 60 \times 1$ (1), axial needle cage $40 \times 60 \times 3$ (2) and running disk (3) $40 \times 60 \times 3.5$ and oil them.

※ Mount running disk (3), with the chamfer showing towards the tapered roller bearing.

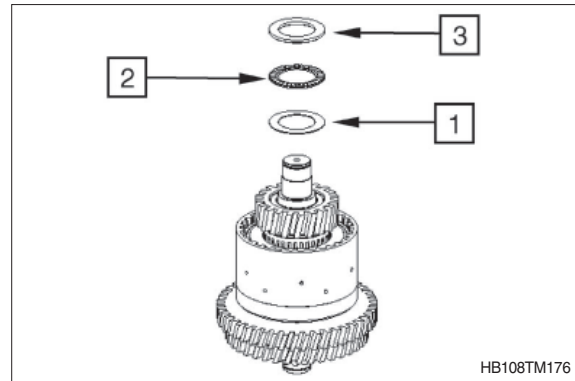

㉑ Heat up bearing inner ring (approx. 120°C).

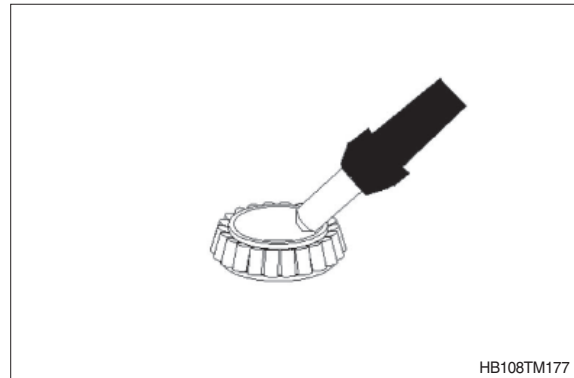

㉒ Mount bearing inner ring (1) until contact is obtained.

㉓ Fit rectangular ring 30×2 (2).

Wear protective gloves.

※ Adjust bearing inner ring after cooling-down.

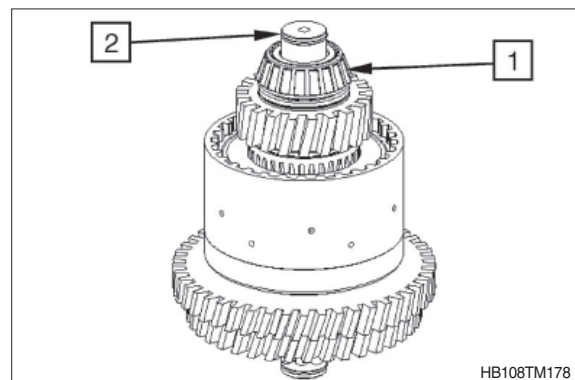

※ Check closing and opening of the clutch by means of compressed air at the hole (see arrow).

Closing and opening of the clutch must be clearly audible.

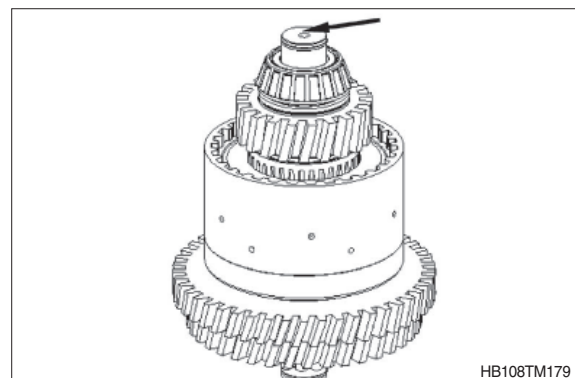

(3) K1 clutch

※ The clutch (1) is supplied by the spare parts service only as a complete assy which consists of:

1A = Helical gear

1B = Disk carrier

1C = Shaft

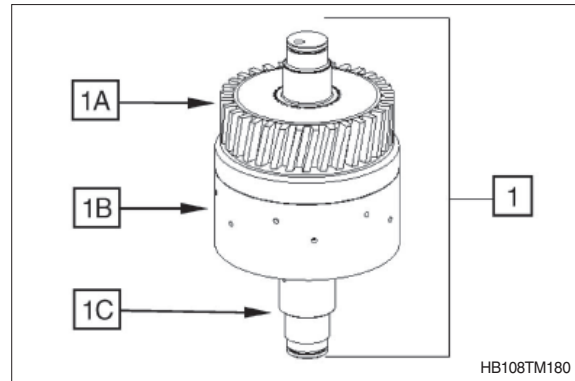

① Heat up bearing inner ring (approx. 120°C).

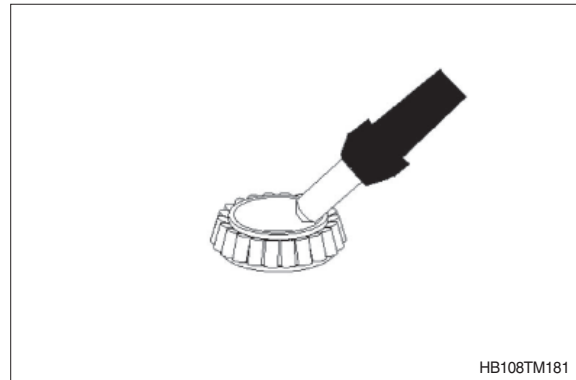

② Mount bearing inner ring (1) until contact is obtained.

③ Fit rectangular ring 30 × 2 (2).

Wear protective gloves.

※ Adjust bearing inner ring after cooling-down.

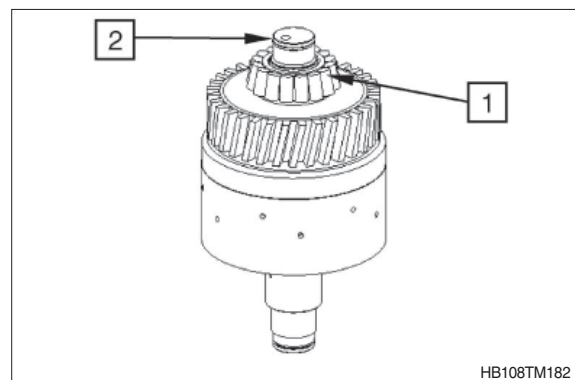

④ Insert both O-rings (1 and 2) into the piston grooves and oil them.

1 = 40 × 3

2 = 104.5 × 3

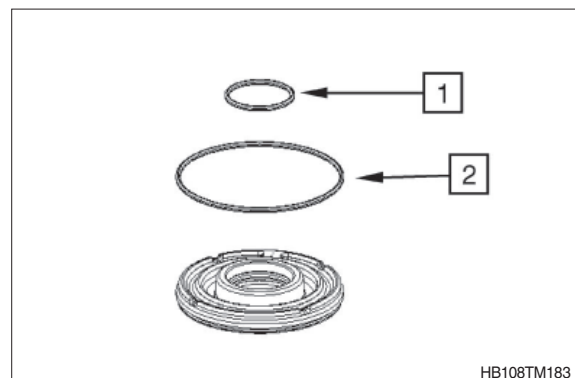

⑤ Insert piston (1) into the disk carrier.

※ Pay attention to the installation position, see figure.

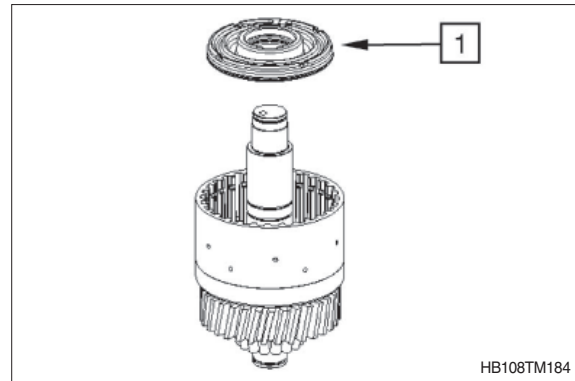

⑥ Use a hand-operated press to place piston into the disk carrier by means of the assembly aid.

(S) Assembly aid 5870 345 114

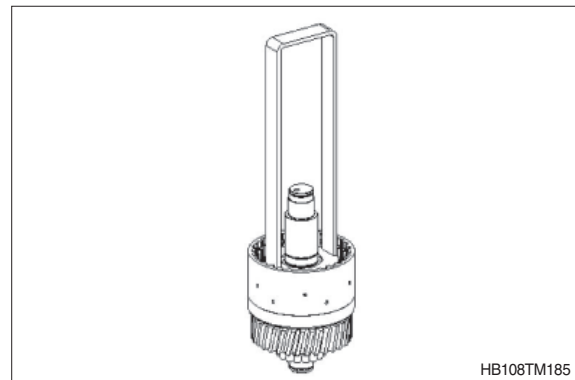

⑦ Mount compression spring (1) and spring cup (2).

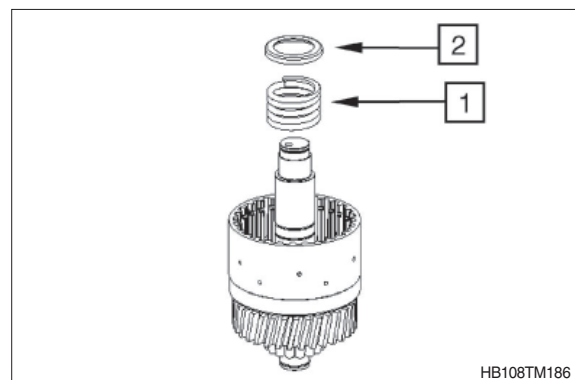

⑧ By means of the assembly aid, preload compression spring under a hand-operated press until the retaining ring 40×1.75 (1) can be snapped in.

(S) Assembly aid 5870 345 114

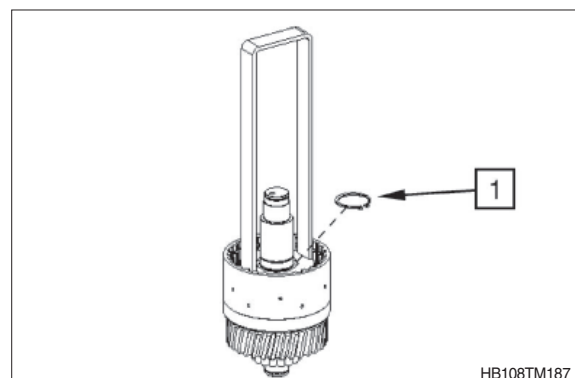

- ⑨ Mount cup spring 112×75×2.55 (1) with the convex side showing towards the piston.

※ Installation position of cup spring see also the next figure ⑩.

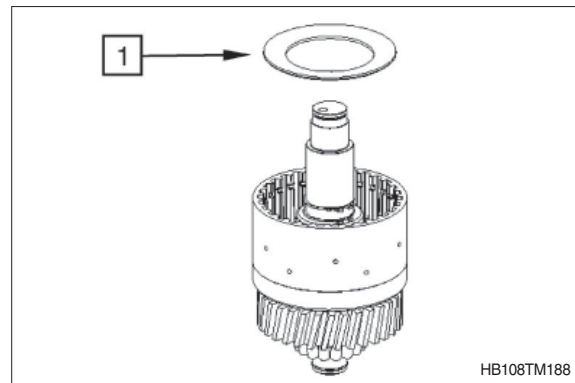

- ⑩ Install cup spring (1) according to the sketch.

Legend:

- 1 = Cup spring 112×75×2.55 (convex side towards the piston)
 2 = Compression spring with spring cup and retaining ring
 3 = Piston with O-rings
 4 = Clutch assy

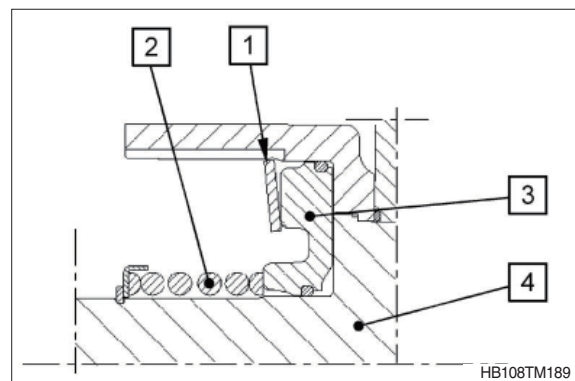

- ⑪ Install outer and inner disks alternately into the disk carrier (3) as shown in figure, starting with an outer disk and ending with an inner disk.

Legend:

- 1 = Outer disks (10 pcs)
 2 = Inner disks (10 pcs)
 3 = Clutch assy

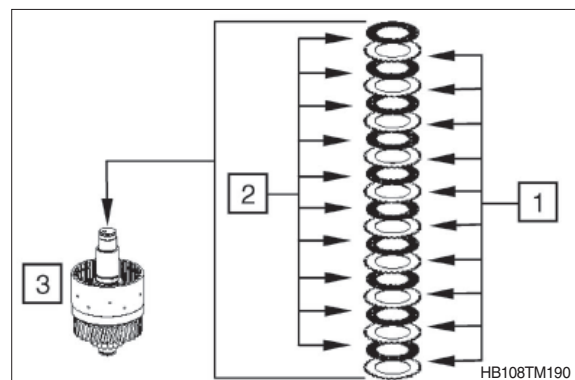

- ⑫ Mount end plate (1) with the flat side showing towards the disk package and fix it by means of snap ring (2) (e.g. thickness = 2.5 mm / recommended value).

※ Pay attention to the installation position of the end plate.

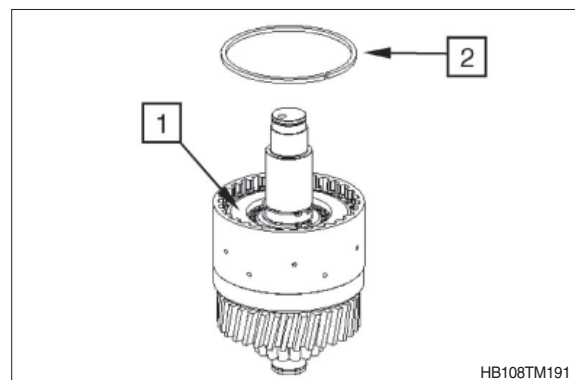

- ⑬ Equally press on end plate with F (approx. 1.8 kg to 2.0 kg) and set dial indicator to "zero".

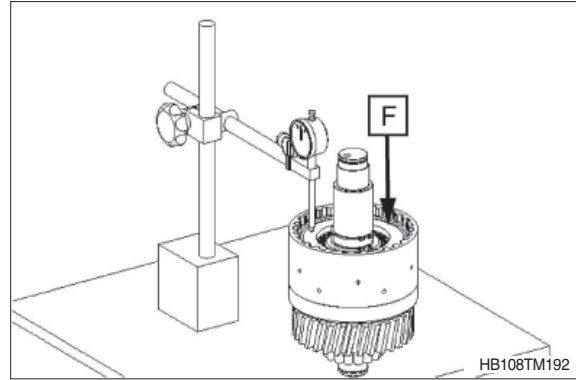

- ⑭ Then press end plate against the snap ring (upwards) and read the disk clearance.

- ※ Disk clearance : 2.0 to 2.3 mm
- ※ In case of deviations, the disk clearance must be corrected with an appropriate snap ring (optional thickness = 2.0 ~ 3.5 mm / available in steps of 0.25 mm)

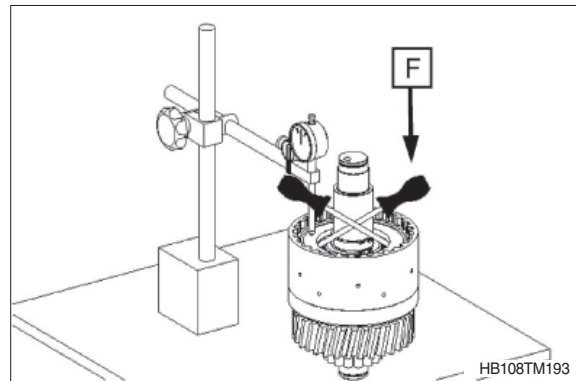

- ⑮ Snap retaining ring 40×1.75 (1) into the groove.

- ※ Contact for axial bearing - see the next figure ⑯.

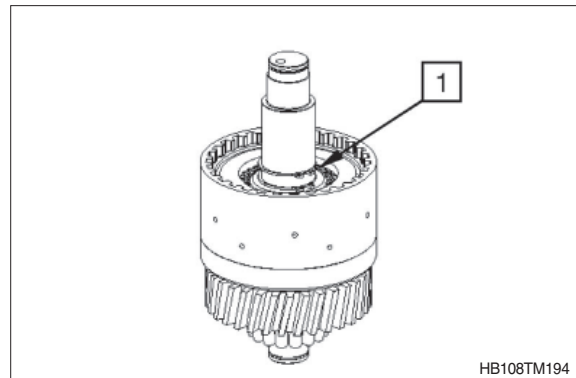

- ⑯ Mount running disk 40×60×3.5 (1), axial needle cage 40×60×3 (2) and axial washer 40×60×1 (3) and oil them.

- ※ Mount running disk (1), with the chamfer showing towards the retaining ring.

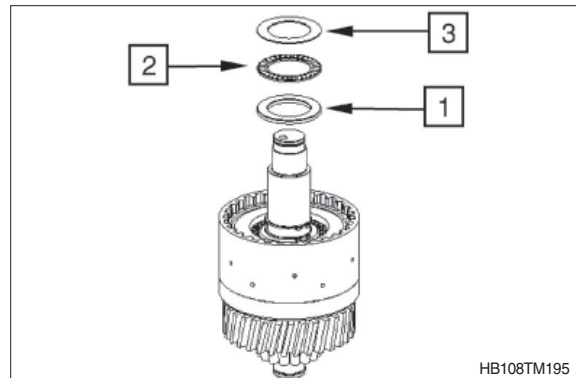

- ⑰ Mount needle cage $40 \times 45 \times 17$ (1) and oil it.

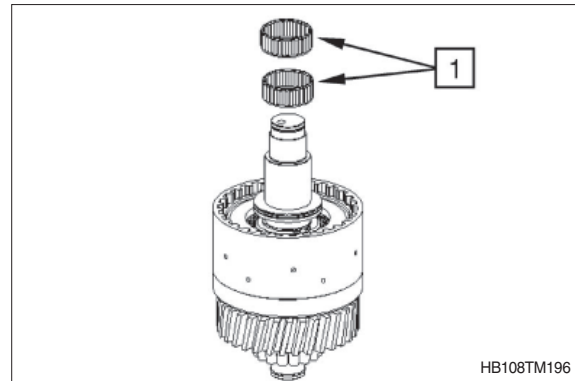

- ⑱ Mount inner disk carrier until contact is obtained.
⑲ Install inner disks by short ccw/cw rotations of the inner disk carrier (1).

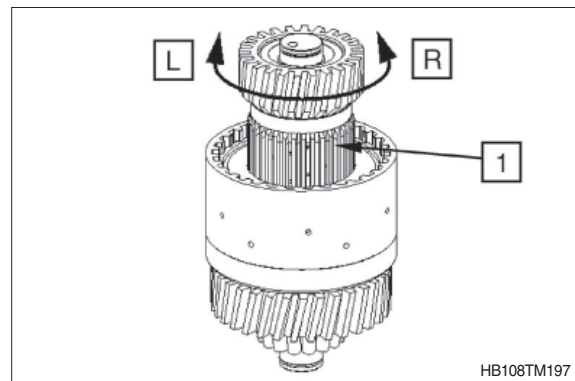

- ⑳ Mount axial washer $40 \times 60 \times 1$ (1), axial needle cage $40 \times 60 \times 3$ (2) and running disk (3) $40 \times 60 \times 3.5$ and oil them.
※ Mount running disk (3), with the chamfer showing towards the tapered roller bearing.

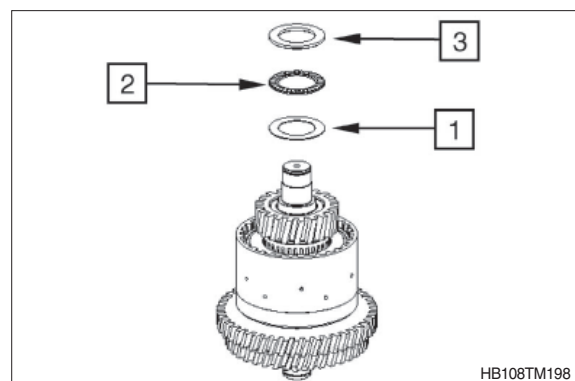

- ㉑ Heat up bearing inner ring (approx. 120°C).

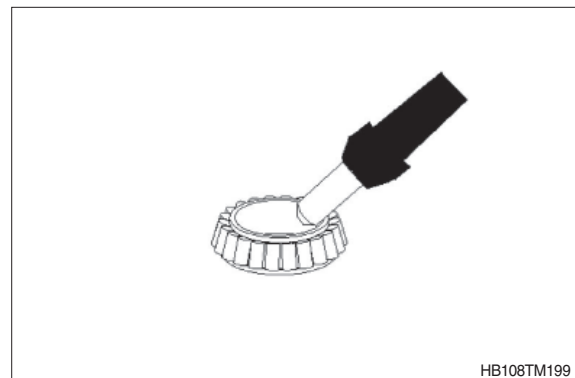

⑳ Mount bearing inner ring (1) until contact is obtained.

㉑ Fit rectangular ring 30 × 2 (2).

Wear protective gloves.

※ Adjust bearing inner ring after cooling-down.

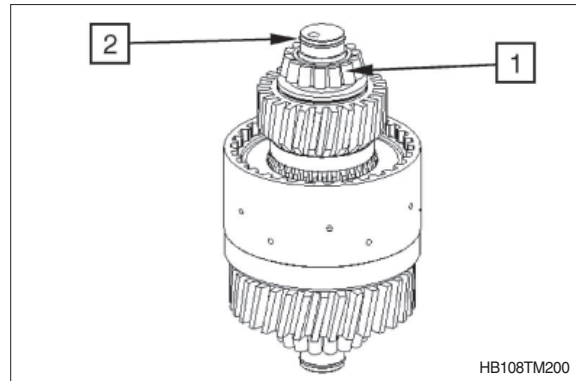

※ Check closing and opening of the clutch by means of compressed air at the hole (see arrow).

Closing and opening of the clutch must be clearly audible.

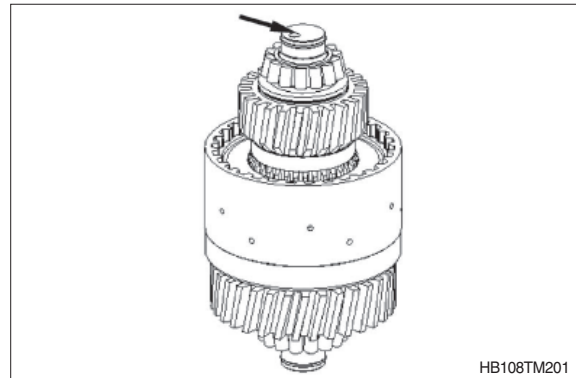

(4) K2 clutch

※ The clutch (1) is supplied by the spare parts service only as a complete assy which consists of:

1A = Ball

1B = Shaft

1C = Helical gear

1D = Disk carrier

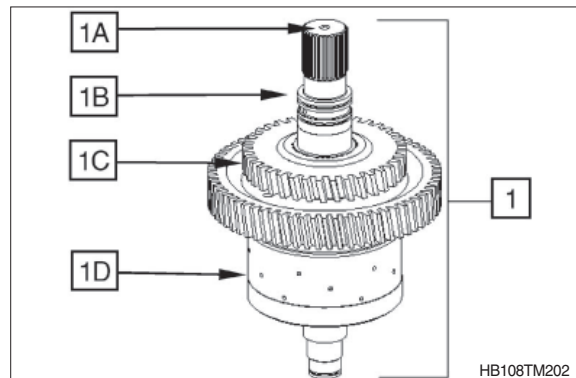

㉒ Heat up bearing inner ring (approx. 120°C).

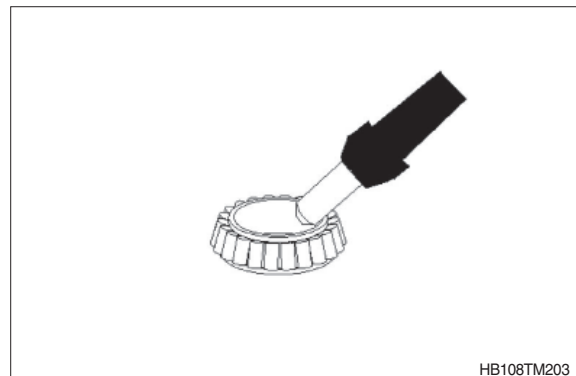

- ② Mount bearing inner ring (1) until contact is obtained.
- ③ Fit rectangular rings 50×2.5 (2).

Wear protective gloves.

- ※ Adjust bearing inner ring after cooling-down.

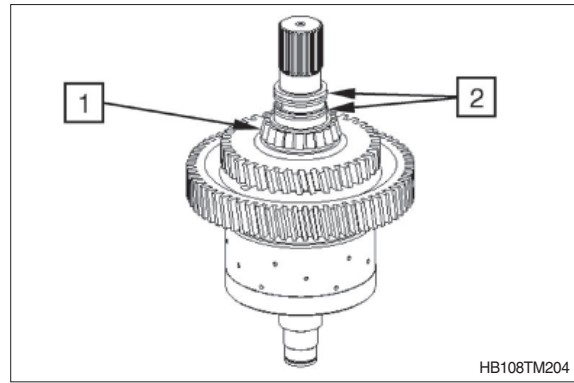

- ④ Insert both O-rings (1 and 2) into the piston grooves and oil them.

1 = 40×3
2 = 115×3

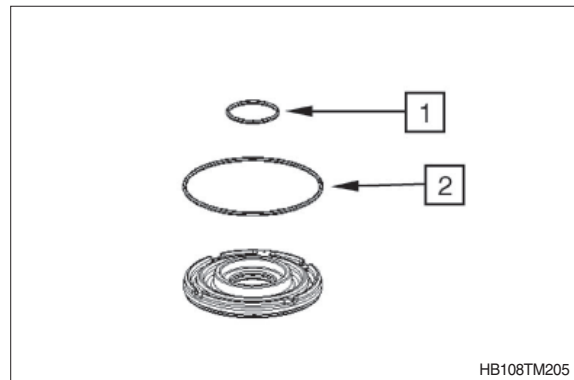

- ⑤ Insert piston (1) into the disk carrier.

- ※ Pay attention to the installation position, see figure.

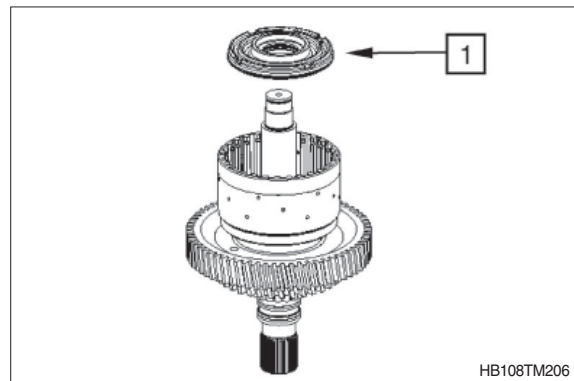

- ⑥ Use a hand-operated press to place piston into the disk carrier by means of the assembly aid.

(S) Assembly aid 5870 345 114

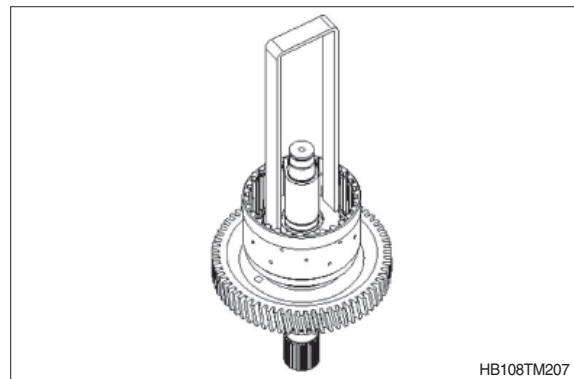

⑦ Mount cup spring package (1) and axial washer (2).

※ Installation position of cup springs see the next figure ⑧.

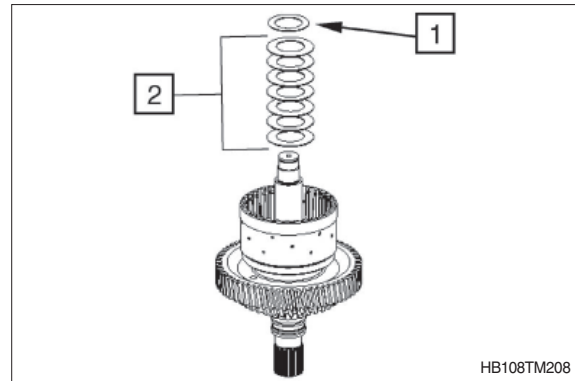

⑧ Fit cup springs according to the sketch.

Legend:

1 = Clutch

2 = Piston with O-rings

3 = Cup springs (7 pcs)

4 = Axial washer (40×60×1)

5 = Retaining ring (40×1.75)

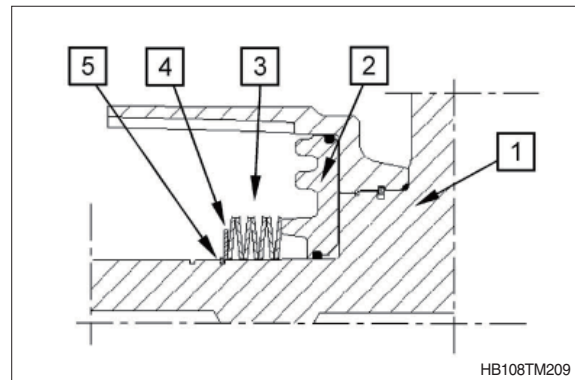

⑨ By means of the assembly aid, preload cup springs under a hand-operated press until the retaining ring 40×1.75 (1) can be snapped in.

(S) Assembly aid

5870 345 114

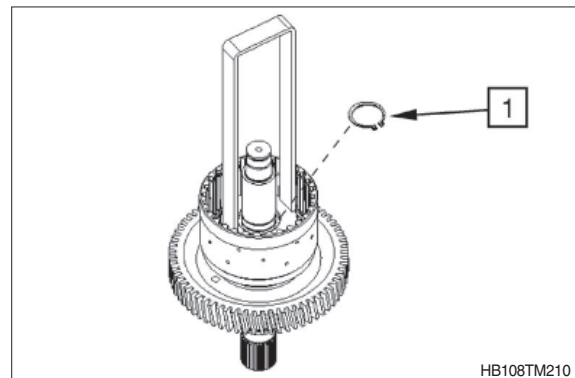

⑩ Mount cup spring 122.7×87×2.55 (1) with the convex side showing towards the piston.

※ Installation position of cup spring see also the next figure ⑪.

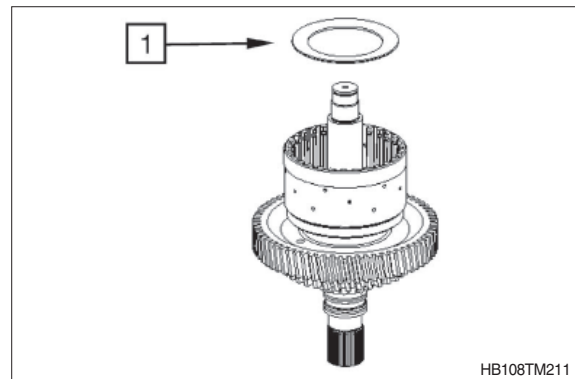

- ⑪ Install cup spring (1) according to the sketch.

Legend:

- 1 = Cup spring $122.7 \times 87 \times 2.55$ (convex side showing towards the piston)
 2 = Compression spring with spring cup and retaining ring
 3 = Piston with O-rings
 4 = Clutch assy

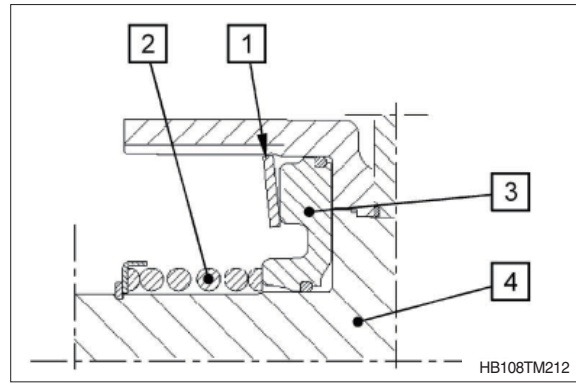

- ⑫ Install outer and inner disks alternately into the disk carrier (3) as shown in figure, starting with an outer disk and ending with an inner disk.

Legend:

- 1 = Outer disks (13 pcs)
 2 = Inner disks (13 pcs)
 3 = Clutch assy

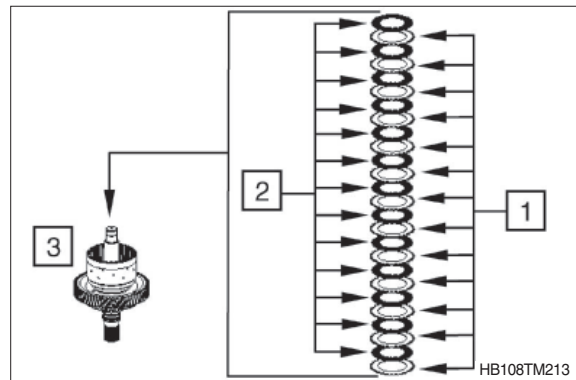

- ⑬ Mount end plate (1) with the flat side showing towards the disk package and fix it by means of snap ring (2) (e.g. thickness = 2.5 mm / recommended value).

※ Pay attention to the installation position of the end plate.

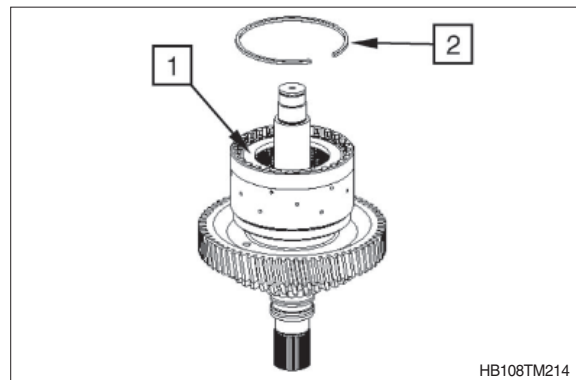

- ⑭ Equally press on end plate with F (approx. 1.8 kg to 2.0 kg) and set dial indicator to "zero".

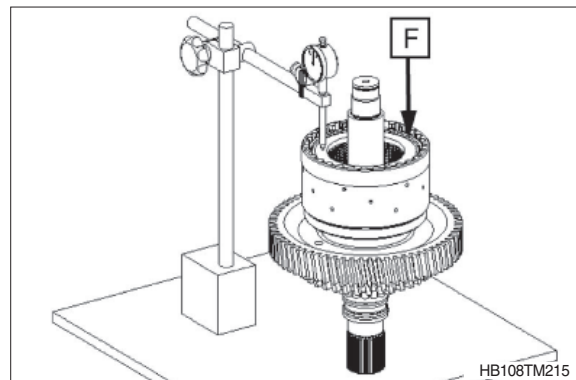

⑮ Then press end plate against the snap ring (upwards) and read the disk clearance.

※ Disk clearance : 2.2 to 2.5 mm

※ In case of deviations, the disk clearance must be corrected with an appropriate snap ring (optional thickness = 2.0 ~ 3.5 mm / available in steps of 0.25 mm)

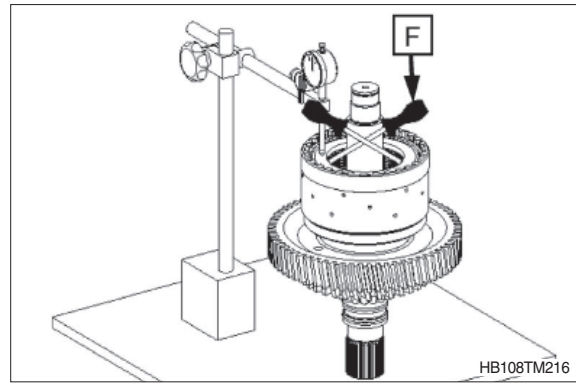

⑯ Snap retaining ring 40×1.75 (1) into the groove.

※ Contact for axial bearing - see figure ⑰.

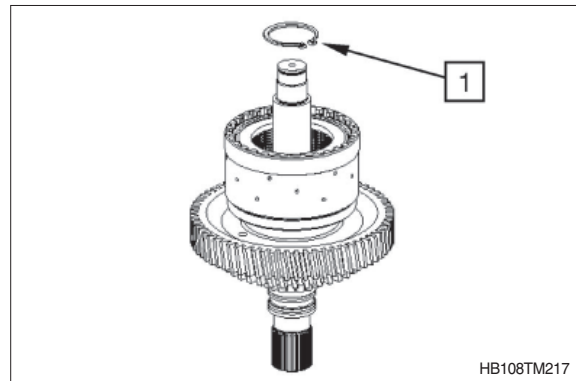

⑰ Mount running disk 40×60×3.5 (1), axial needle cage 40×60×3 (2) and axial washer 40×60×1 (3) and oil them.

※ Mount running disk (1), with the chamfer showing towards the retaining ring.

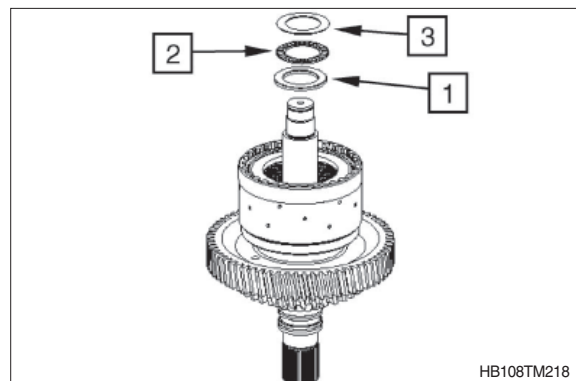

⑱ Mount needle cage 40×45×17 (1) and bushing (2) and oil them.

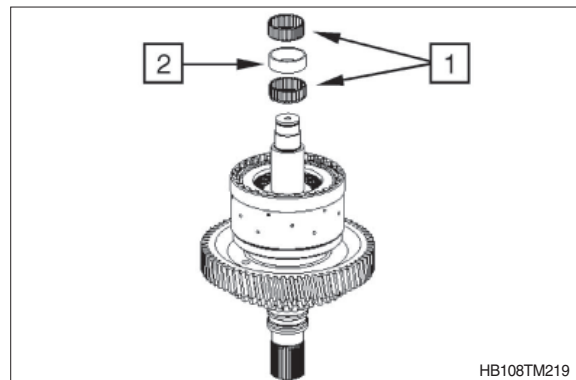

- ⑲ Mount inner disk carrier until contact is obtained.
- ⑳ Install inner disks by short ccw/cw rotations of the inner disk carrier (1).

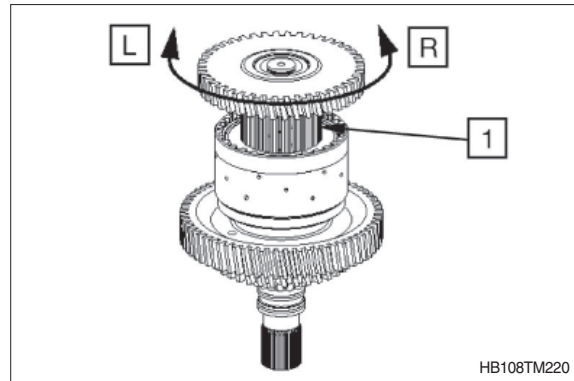

- ㉑ Mount axial washer $40 \times 60 \times 1$ (1), axial needle cage $40 \times 60 \times 3$ (2) and running disk (3) $40 \times 60 \times 3.5$ and oil them.
- ※ Mount running disk (3), with the chamfer showing towards the tapered roller bearing.

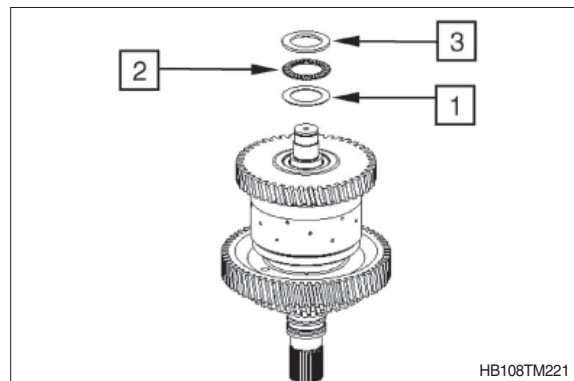

- ㉒ Heat up bearing inner ring (approx. 120°C).

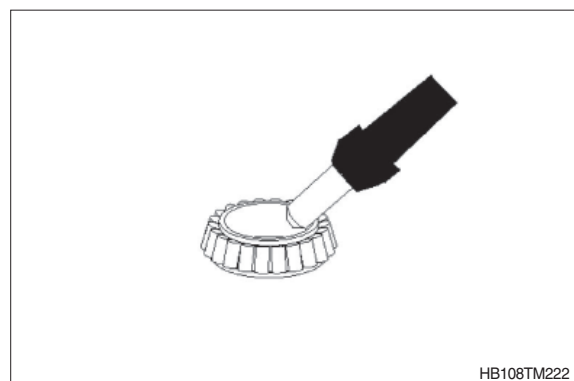

- ㉓ Mount bearing inner ring (1) until contact is obtained.
- ㉔ Fit rectangular ring 30×2 (2).

Wear protective gloves.

- ※ Adjust bearing inner ring after cooling-down.

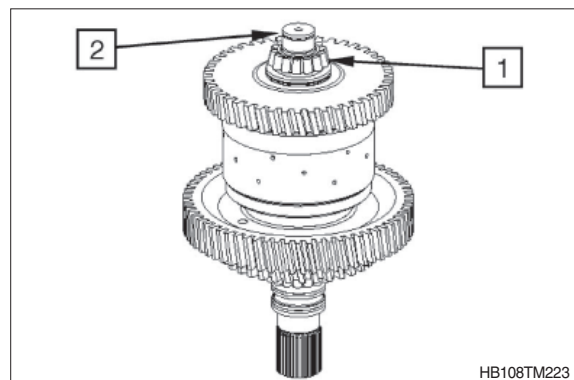

- ※ Check closing and opening of the clutch by means of compressed air at the hole (see arrow).
- Closing and opening of the clutch must be clearly audible.

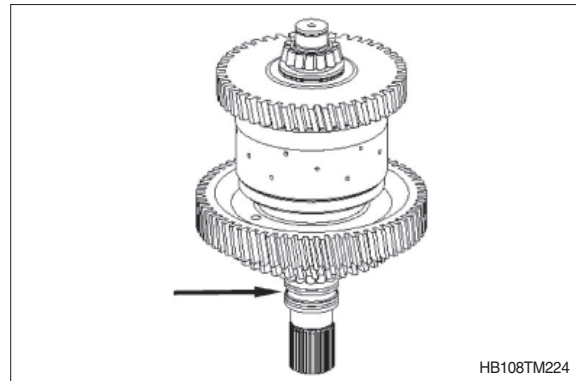

(5) K3 clutch

- ※ The clutch (1) is supplied by the spare parts service only as a complete assy which consists of:
 - 1A = Helical gear
 - 1B = Disk carrier
 - 1C = Shaft

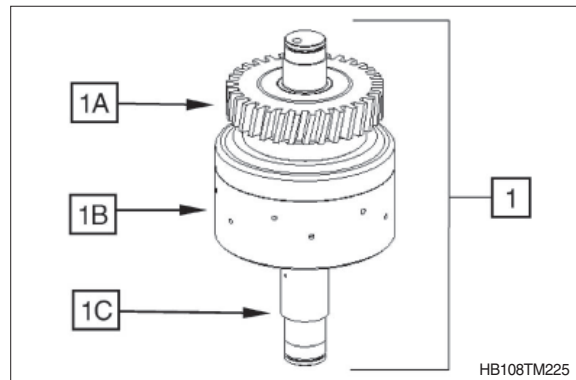

- ① Heat up bearing inner ring (approx. 120°C).

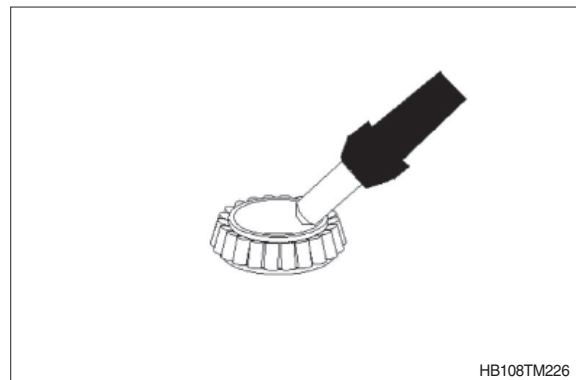

- ② Mount bearing inner ring (1) until contact is obtained.
- ③ Fit rectangular rings 30×2 (2).

Wear protective gloves.

- ※ Adjust bearing inner ring after cooling-down.

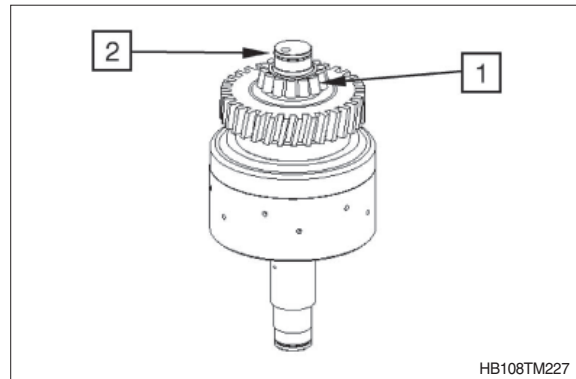

- ④ Insert both O-rings (1 and 2) into the piston grooves and oil them.

1 = 40×3

2 = 104.5×3

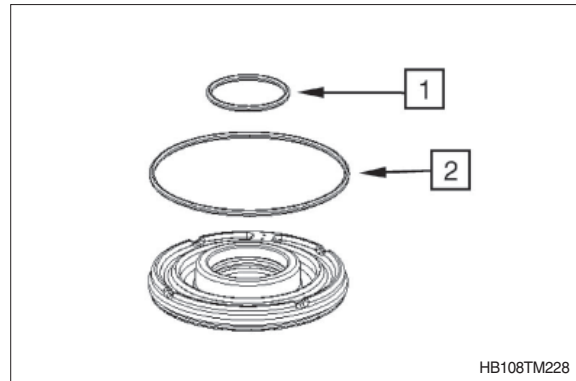

- ⑤ Insert piston (1) into the disk carrier.

※ Pay attention to the installation position, see figure.

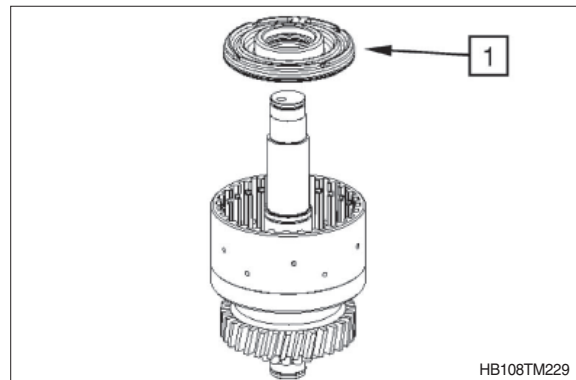

- ⑥ Use a hand-operated press to place piston into the disk carrier by means of the assembly aid.

(S) Assembly aid

5870 345 114

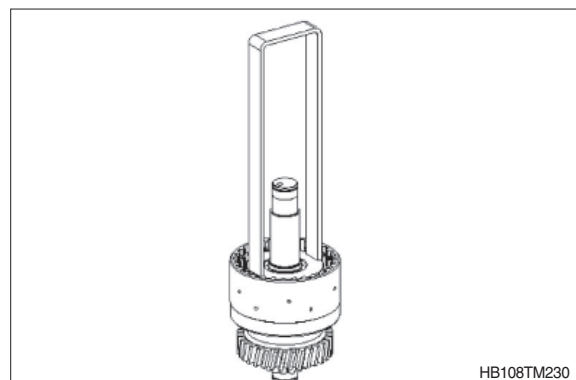

- ⑦ Mount compression spring (1) and spring cup (2).

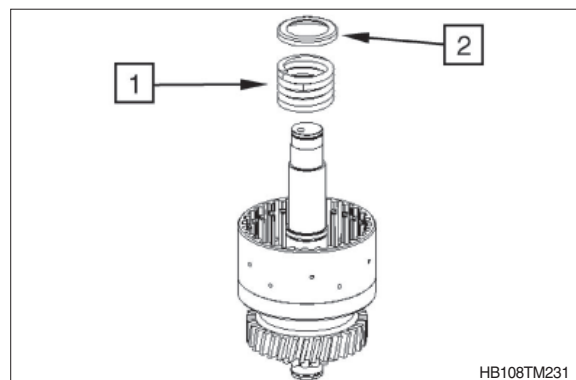

- ⑧ By means of the assembly aid, preload compression spring under a hand-operated press until the retaining ring 40×1.75 (1) can be snapped in.

(S) Assembly aid 5870 345 114

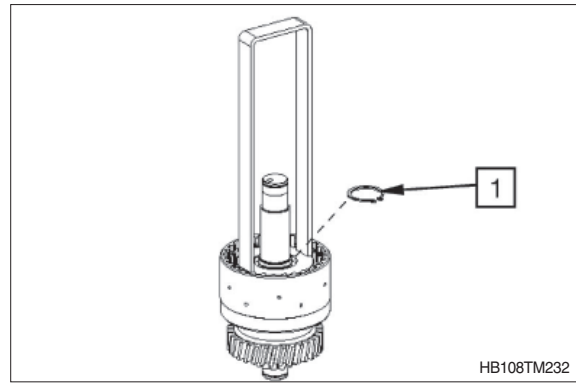

- ⑨ Mount cup spring $112 \times 75 \times 2.55$ (1) with the convex side showing towards the piston.

※ Installation position of cup spring see also the next figure ⑩.

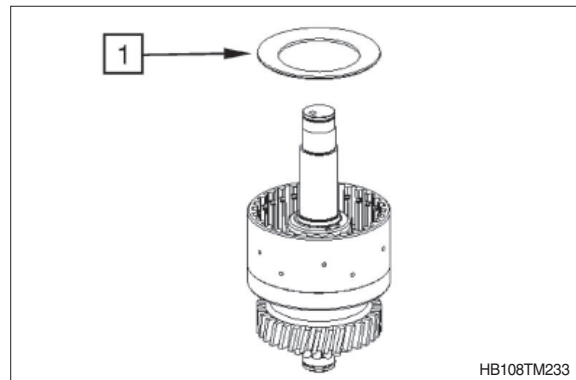

- ⑩ Install cup spring (1) according to the sketch.

Legend:

- 1 = Cup spring $112 \times 75 \times 2.55$ (convex side showing towards the piston)
- 2 = Compression spring with spring cup and retaining ring
- 3 = Piston with O-rings
- 4 = Clutch assy

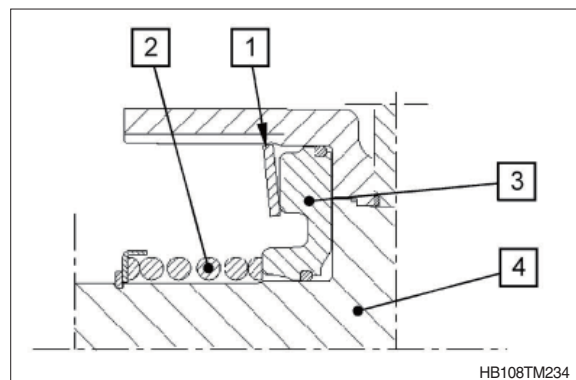

- ⑪ Install outer and inner disks alternately into the disk carrier (3) as shown in figure, starting with an outer disk and ending with an inner disk.

Legend:

- 1 = Outer disks (9 pcs)
- 2 = Inner disks (9 pcs)
- 3 = Clutch assy

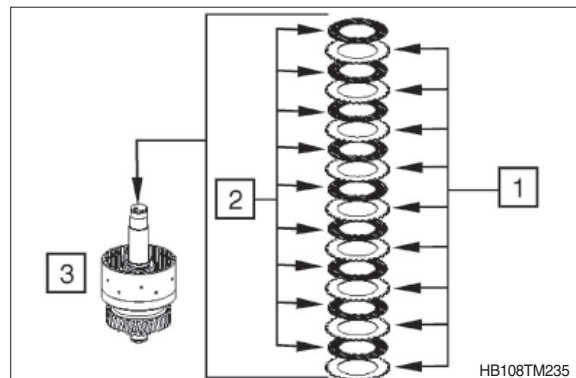

- ⑫ Mount end plate (1) with the flat side showing towards the disk package and fix it by means of snap ring (2) (e.g. thickness = 2.5 mm / recommended value).

※ Pay attention to the installation position of the end plate.

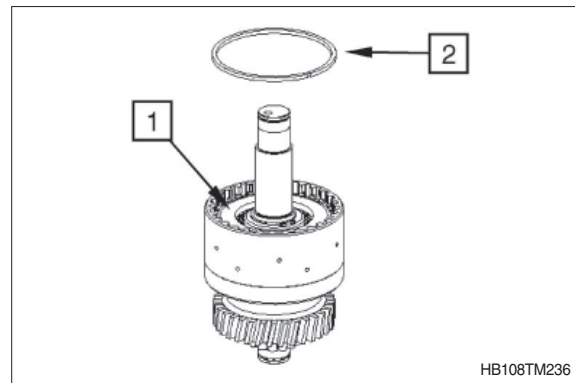

HB108TM236

- ⑬ Equally press on end plate with F (approx. 1.8 kg to 2.0 kg) and set dial indicator to "zero".

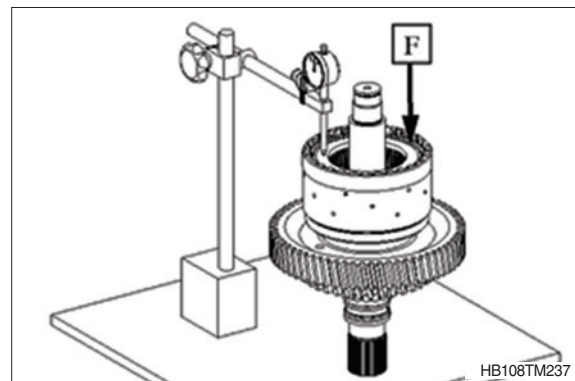

HB108TM237

- ⑭ Then press end plate against the snap ring (upwards) and read the disk clearance.

※ Disk clearance : 1.8 to 2.1 mm

※ In case of deviations, the disk clearance must be corrected with an appropriate snap ring (optional thickness = 2.0 ~ 3.5 mm / available in steps of 0.25 mm)

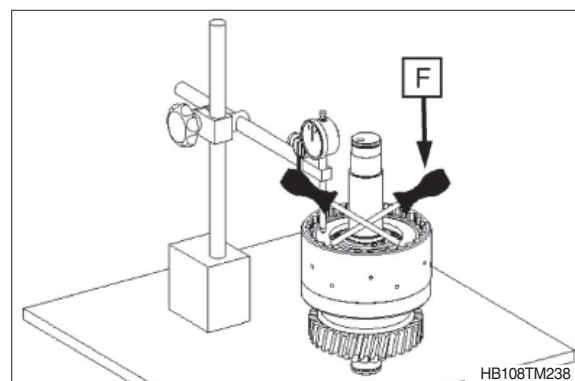

HB108TM238

- ⑮ Mount running disk $35 \times 52 \times 3.5$ (1), axial needle cage $35 \times 52 \times 2$ (2) and axial washer $35 \times 52 \times 1$ (3) and oil them.

※ Mount running disk (1), with the chamfer showing towards the retaining ring.

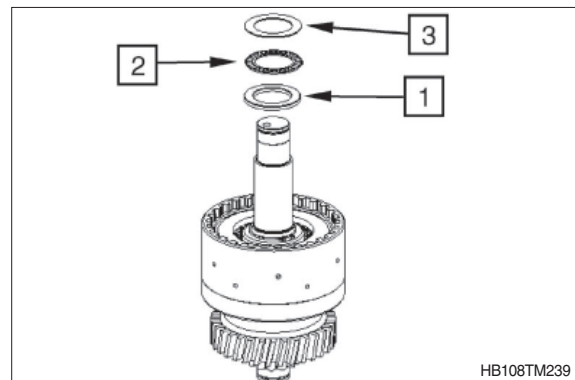

HB108TM239

- ⑩ Mount needle cage $35 \times 42 \times 18$ (1) and bushing (2) and oil them.

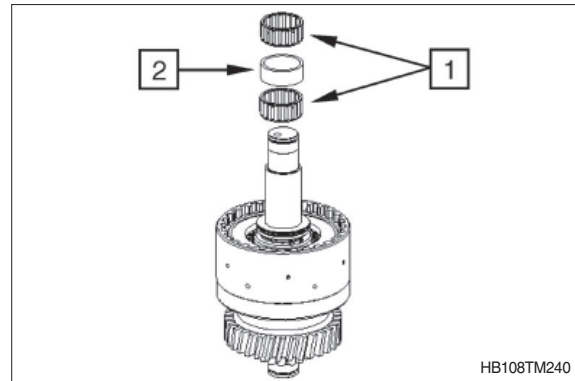

- ⑪ Mount inner disk carrier until contact is obtained.
⑫ Install inner disks by short ccw/cw rotations of the inner disk carrier (1).

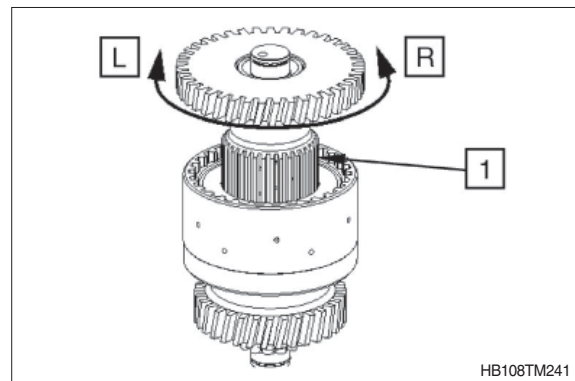

- ⑬ Mount axial washer $35 \times 52 \times 1$ (1), axial needle cage $35 \times 52 \times 2$ (2) and running disk (3) $35 \times 52 \times 3.5$ and oil them.
※ Mount running disk (3), with the chamfer showing towards the tapered roller bearing.

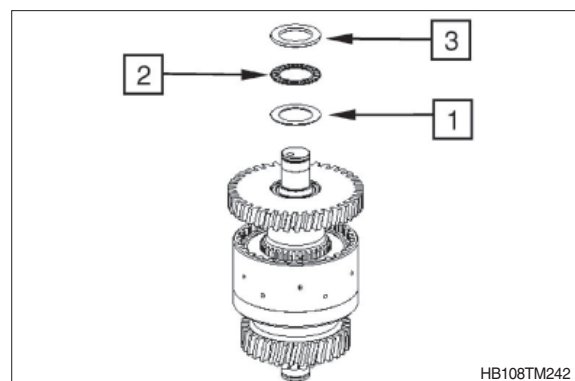

- ⑭ Heat up bearing inner ring (approx. 120°C).

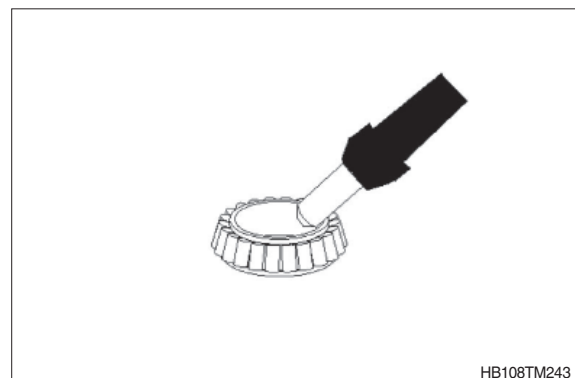

- ① Mount bearing inner ring (1) until contact is obtained.
- ② Fit rectangular ring 30 × 2 (2).

Wear protective gloves.

- ※ Adjust bearing inner ring after cooling-down.

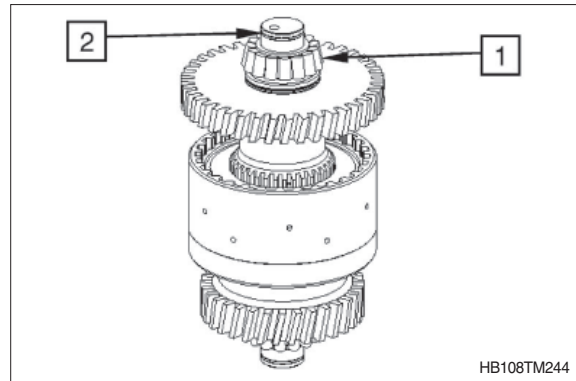

HB108TM244

- ※ Check closing and opening of the clutch by means of compressed air at the hole (see arrow).
- Closing and opening of the clutch must be clearly audible.

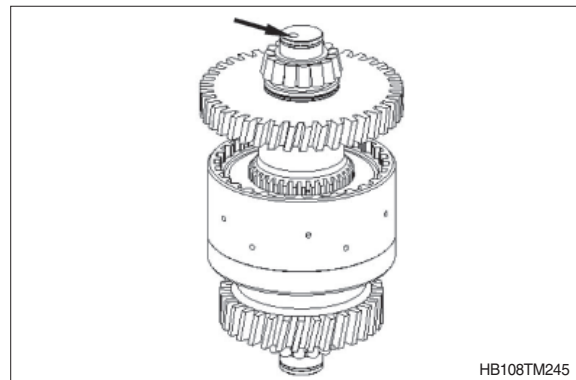

HB108TM245

(6) K4 clutch

- ※ The clutch (1) is supplied by the spare parts service only as a complete assy which consists of:

- 1A = Retaining ring
- 1B = Helical gear
- 1C = Disk carrier
- 1D = Shaft

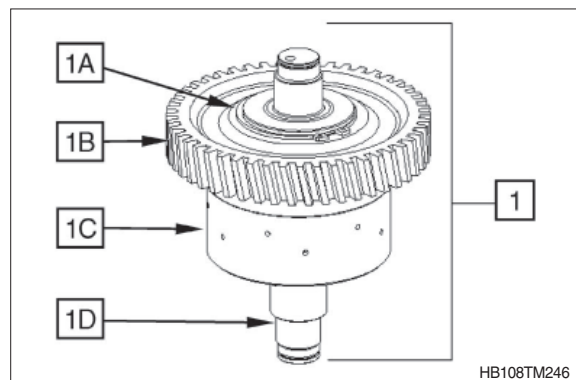

HB108TM246

- ① Heat up bearing inner ring (approx. 120°C).

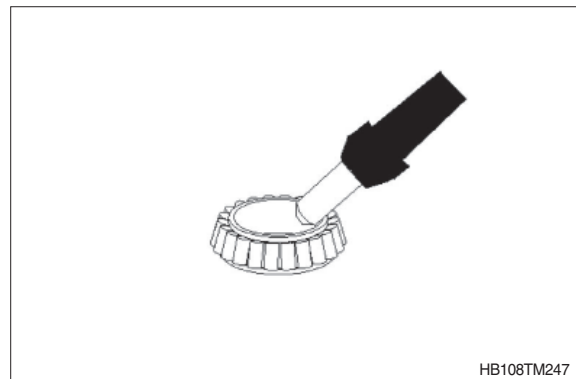

HB108TM247

- ② Mount bearing inner ring (1) until contact is obtained.
- ③ Fit rectangular rings 30×2 (2).

Wear protective gloves.

- ※ Adjust bearing inner ring after cooling-down.

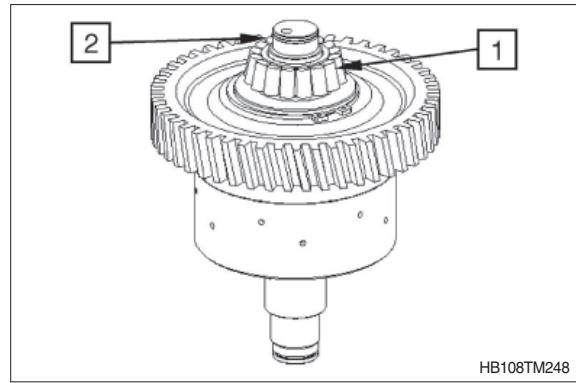

HB108TM248

- ④ Insert both O-rings (1 and 2) into the piston grooves and oil them.

1 = 40×3

2 = 104.5×3

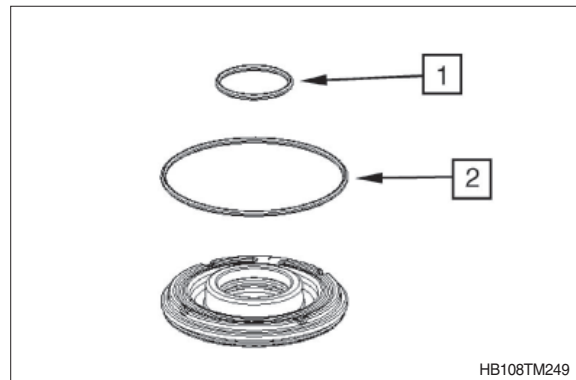

HB108TM249

- ⑤ Insert piston (1) into the disk carrier.

- ※ Pay attention to the installation position, see figure.

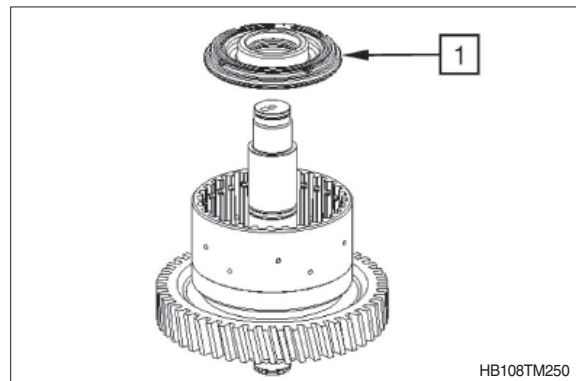

HB108TM250

- ⑥ Use a hand-operated press to place piston into the disk carrier by means of the assembly aid.

(S) Assembly aid

5870 345 114

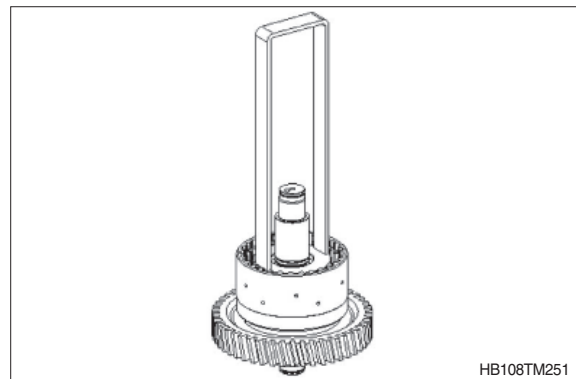

HB108TM251

- ⑦ Mount compression spring (1) and spring cup (2).

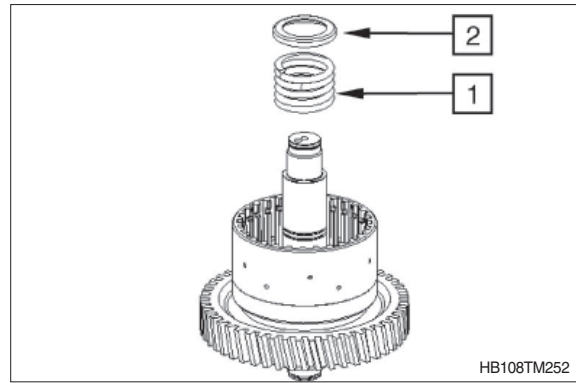

- ⑧ By means of the assembly aid, preload compression spring under a hand-operated press until the retaining ring 40×1.75 (1) can be snapped in.

(S) Assembly aid 5870 345 114

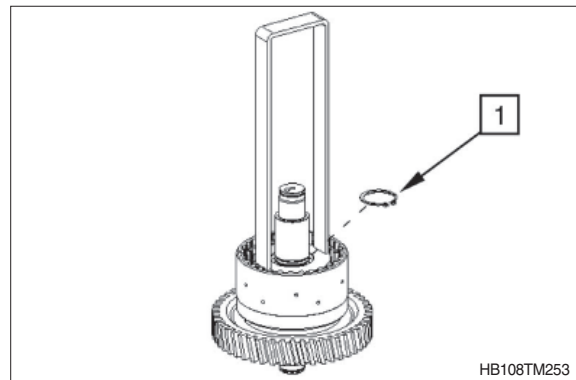

- ⑨ Mount plate assy with cup springs (1), with the open side showing towards the piston.

※ Installation position of plate see also the next figure ⑩.

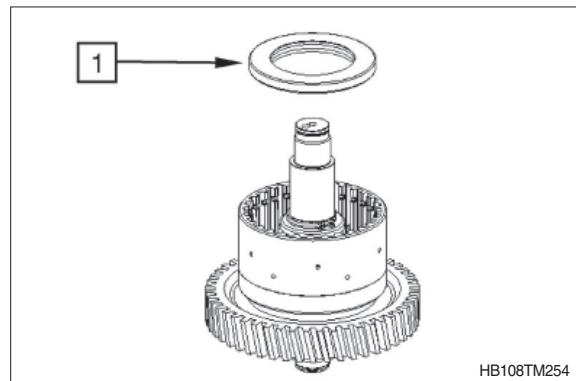

- ⑩ Fit plate (1) according to sketch (see arrow).

Legend:

- 1 = Plate assy with cup springs
- 2 = Compression spring with spring cup and retaining ring
- 3 = Piston with O-rings
- 4 = Input shaft assy

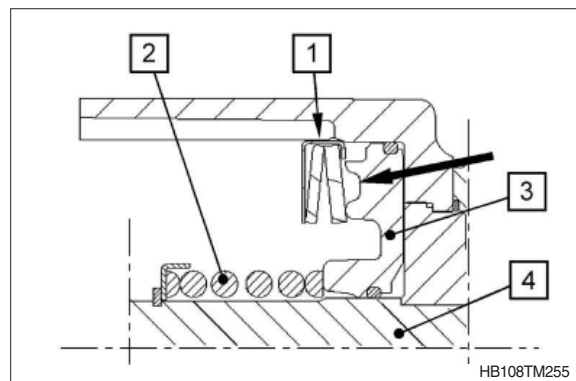

- ⑪ Install outer and inner disks alternately into the disk carrier (3) as shown in figure, starting with an outer disk and ending with an inner disk.

Legend:

- 1 = Outer disks (7 pcs)
- 2 = Inner disks (7 pcs)
- 3 = Clutch assy

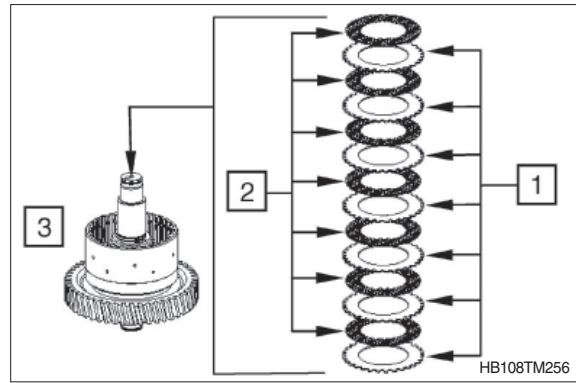

- ⑫ Mount end plate (1) with the flat side showing towards the disk package and fix it by means of snap ring (2) (e.g. thickness = 2.5 mm / recommended value).

- ※ Pay attention to the installation position of the end plate.

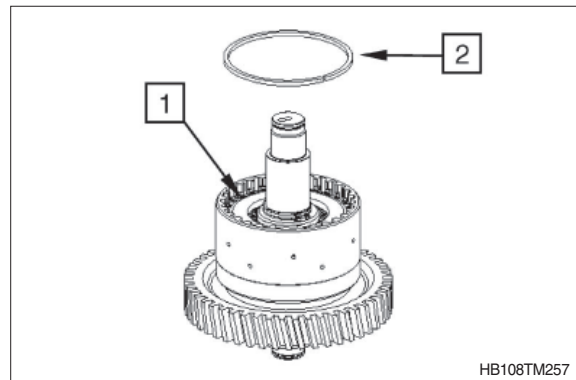

- ⑬ Equally press on end plate with F (approx. 1.8 kg to 2.0 kg) and set dial indicator to "zero".

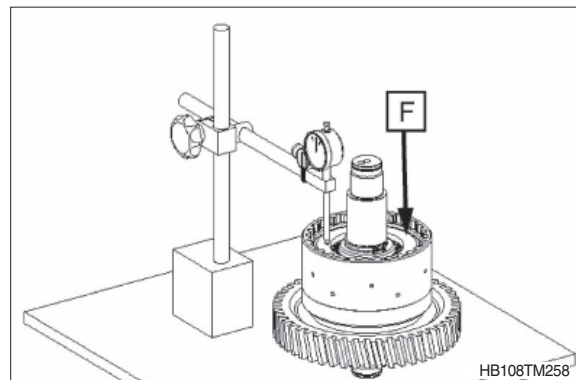

- ⑭ Then press end plate against the snap ring (upwards) and read the disk clearance.

- ※ Disk clearance : 1.4 to 1.7 mm
- ※ In case of deviations, the disk clearance must be corrected with an appropriate snap ring (optional thickness = 2.0 ~ 3.5 mm / available in steps of 0.25 mm)

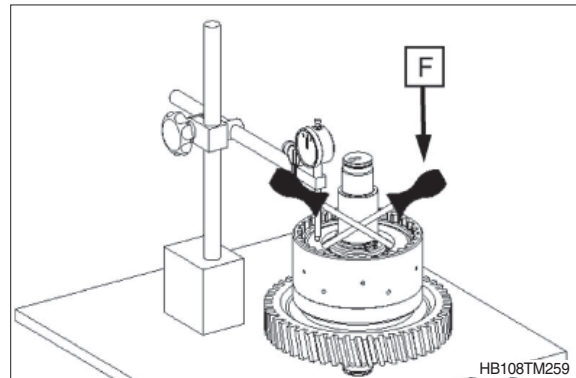

⑮ Snap retaining ring 40×1.75 (1) into the groove.

※ Contact for axial bearing - see the next figure ⑯.

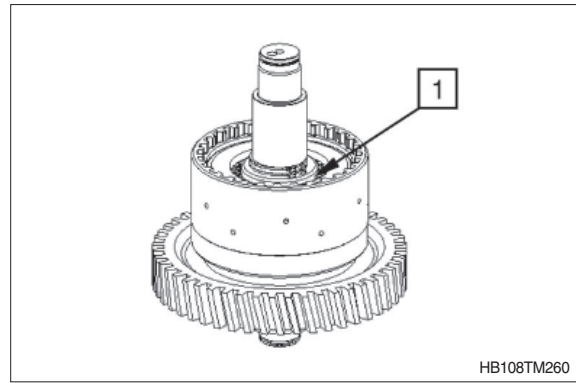

⑯ Mount running disk $40 \times 60 \times 3.5$ (1), axial needle cage $40 \times 60 \times 3$ (2) and axial washer $40 \times 60 \times 1$ (3) and oil them.

※ Mount running disk (1) with the chamfer showing towards the retaining ring.

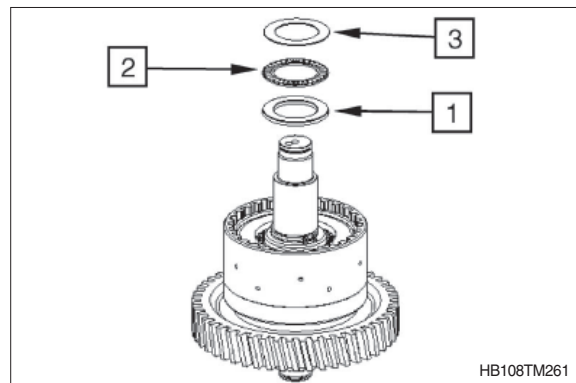

⑰ Mount needle cage $40 \times 45 \times 17$ (1) and oil it.

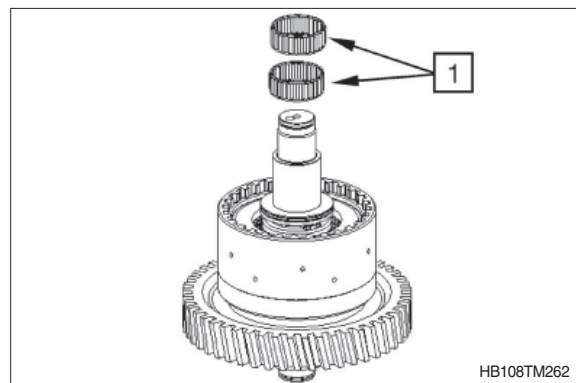

⑱ Mount inner disk carrier until contact is obtained.

⑲ Install inner disks by short ccw/cw rotations of the inner disk carrier (1).

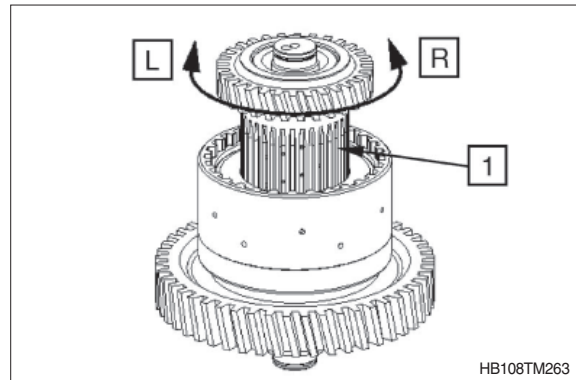

⑳ Mount axial washer $40 \times 60 \times 1$ (1), axial needle cage $40 \times 60 \times 3$ (2) and running disk (3) $40 \times 60 \times 3.5$ and oil them.

※ Mount running disk (3), with the chamfer showing towards the tapered roller bearing.

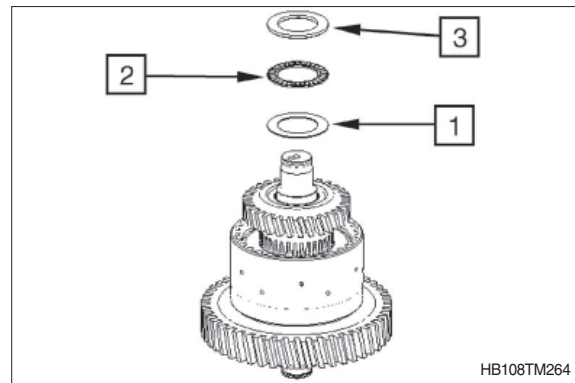

㉑ Heat up bearing inner ring (approx. 120°C).

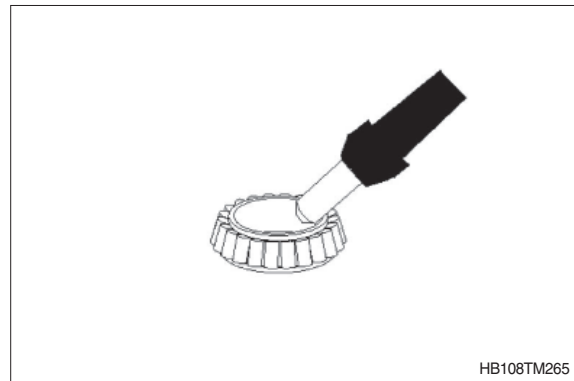

㉒ Mount bearing inner ring (1) until contact is obtained.

㉓ Fit rectangular ring 30×2 (2).

Wear protective gloves.

※ Adjust bearing inner ring after cooling-down.

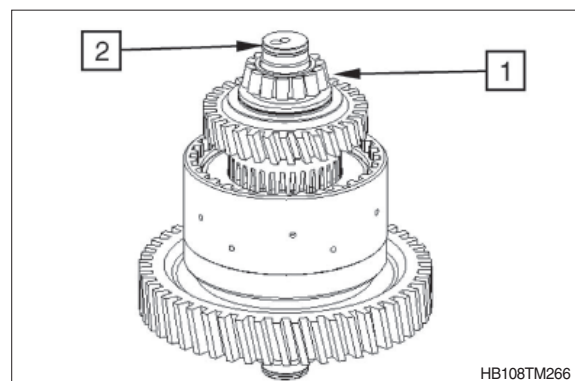

※ Check closing and opening of the clutch by means of compressed air at the hole (see arrow).

Closing and opening of the clutch must be clearly audible.

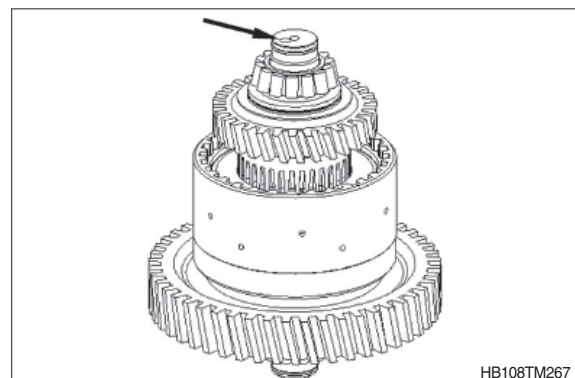

(7) Front wheel drive (VA)

※ The clutch (1) is supplied by the spare parts service only as a complete assy which consists of:

1A = Shaft

1B = Disk carrier

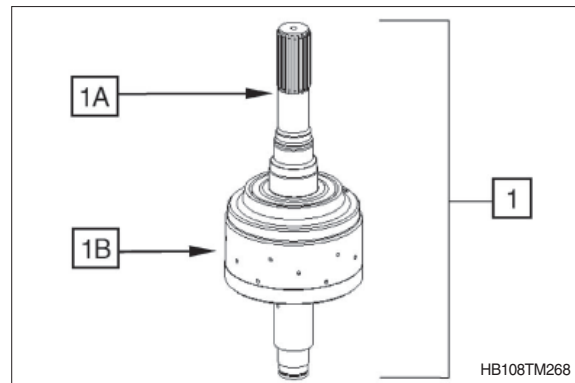

① Heat up bearing inner ring (approx. 120°C).

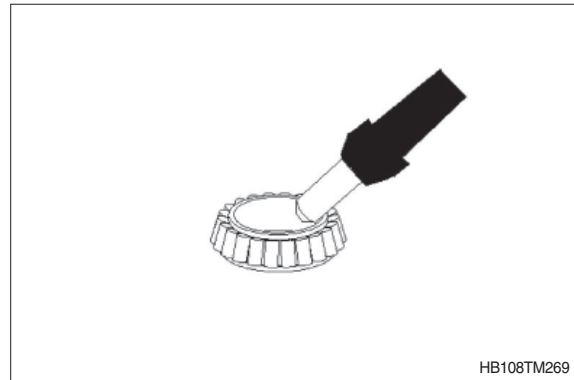

② Mount bearing inner ring (1) until contact is obtained.

Wear protective gloves.

※ Adjust bearing inner ring after cooling-down.

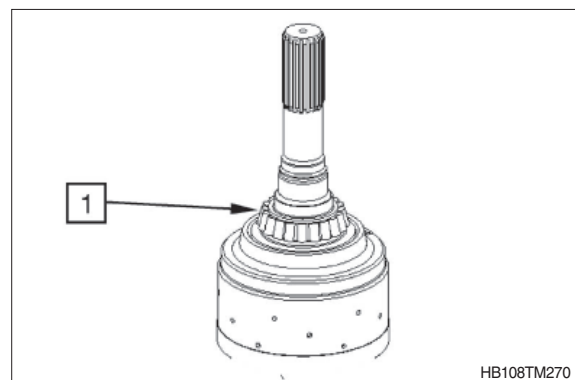

③ Insert piston (1) into the disk carrier.

※ Oil both sealing lips.

※ Pay attention to the installation position, see figure.

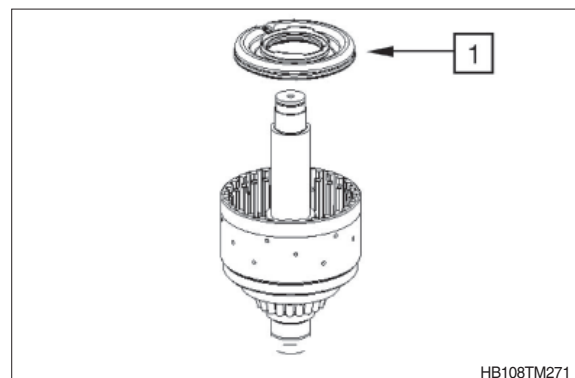

- ④ Use a hand-operated press to place piston into the disk carrier by means of the assembly aid.

(S) Assembly aid 5870 345 114

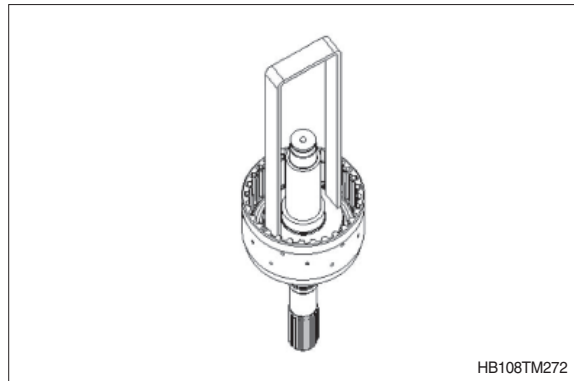

HB108TM272

- ⑤ Mount cup spring package (1) and washer (2).

※ Installation position of cup springs see the next figure ⑥.

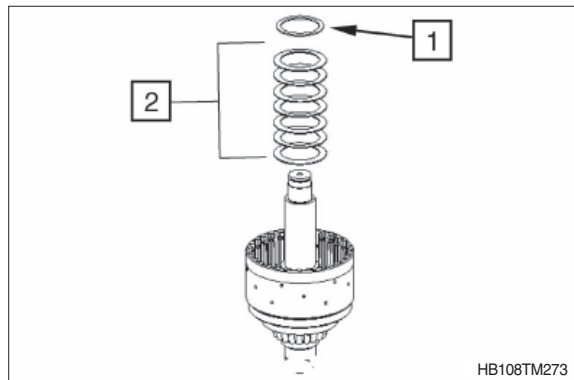

HB108TM273

- ⑥ Fit cup springs according to the sketch.

Legend:

1 = Clutch

2 = Piston

3 = Cup springs (7 pcs)

4 = Washer

5 = Retaining ring (50×2)

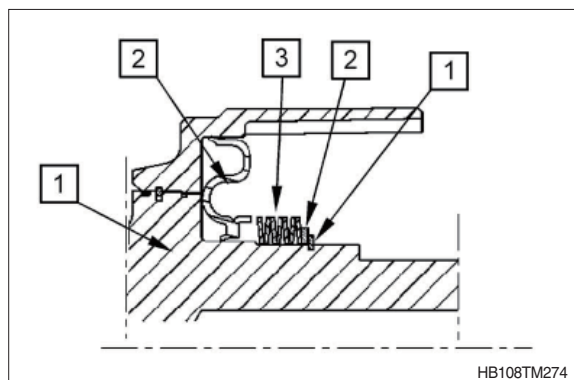

HB108TM274

- ⑦ By means of the assembly aid, preload cup springs under a handoperated press until the retaining ring 50×2 (1) can be snapped in.

(S) Assembly aid 5870 506 128

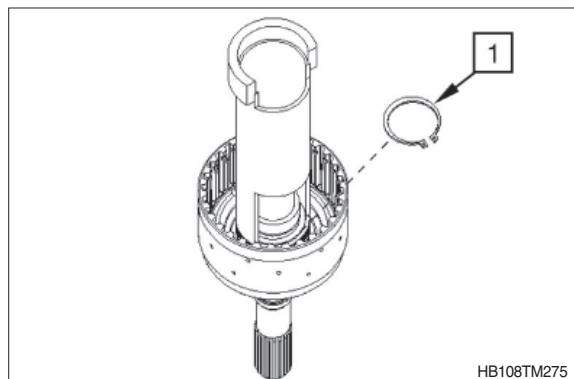

HB108TM275

- ⑧ Install outer and inner disks alternately into the disk carrier (3) as shown in figure, starting with an outer disk and ending with an inner disk.

Legend:

- 1 = Outer disks (12 pcs)
2 = Inner disks (12 pcs)
3 = Clutch assy

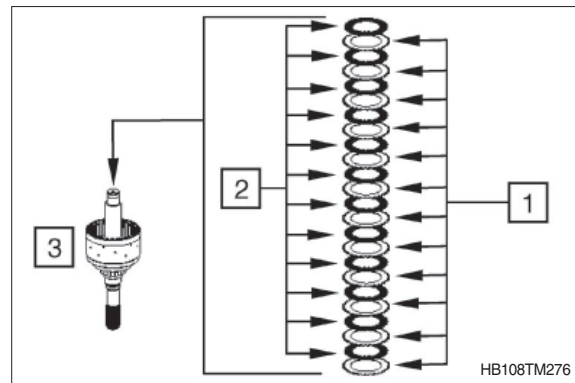

- ⑨ Mount end plate (1) with the flat side showing towards the disk package and fix it by means of snap ring (2) (e.g. thickness = 2.5 mm / recommended value).

- ※ Pay attention to the installation position of the end plate.

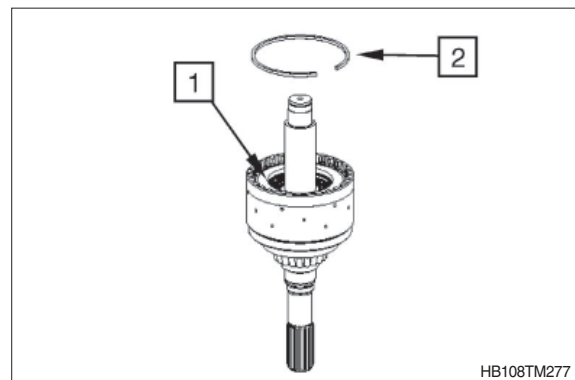

- ⑩ Equally press on end plate with F (approx. 1.8 kg to 2.0 kg) and set dial indicator to "zero".

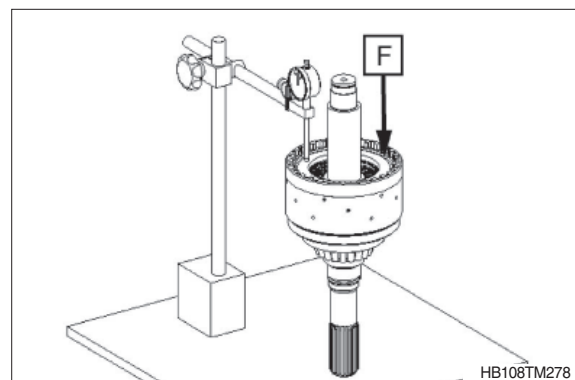

- ⑪ Then press end plate against the snap ring (upwards) and read the disk clearance.

Disk clearance : 2.3 to 2.8 mm

- ※ In case of deviations, the disk clearance must be corrected with an appropriate snap ring (optional thickness = 2.0 ~ 4.0 mm / available in steps of 0.25 mm)

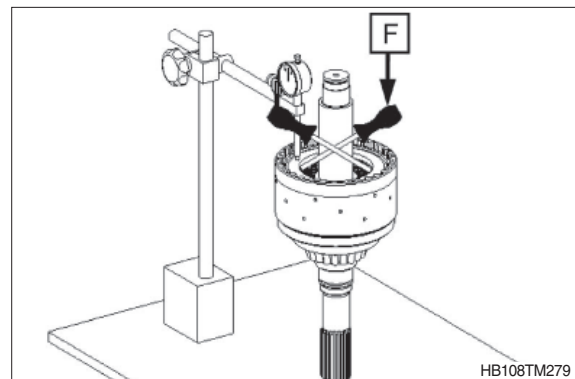

- ⑫ Mount inner disk carrier until contact is obtained.

Install inner disks by short ccw/cw rotations of the inner disk carrier (1).

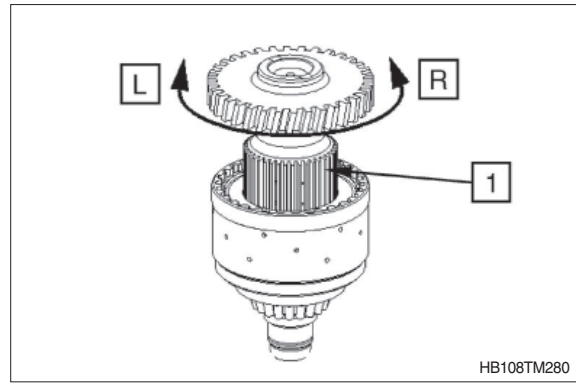

- ⑬ Mount running disk 40 × 60 × 3.5 (1).

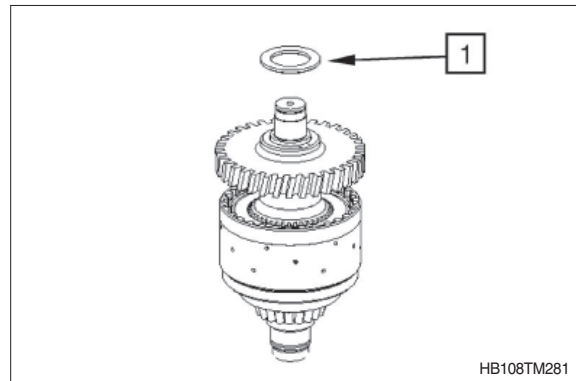

- ⑭ Heat up bearing inner ring (approx. 120°C).

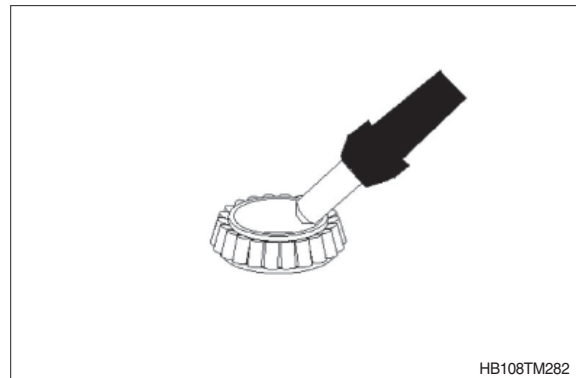

- ⑮ Mount bearing inner ring (1) until contact is obtained.

Fit rectangular ring 30 × 2 (2).

Wear protective gloves.

- ※ Adjust bearing inner ring after cooling-down.

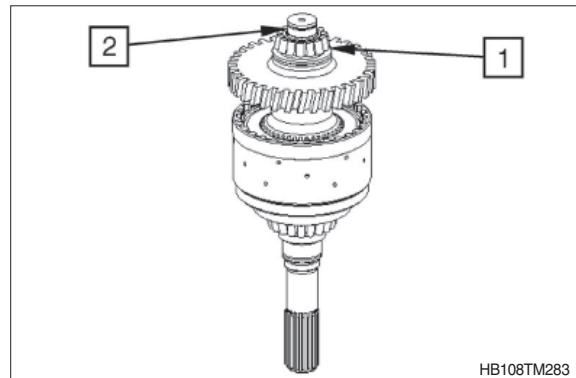

- ※ Check closing and opening of the clutch by means of compressed air at the hole (see arrow).
Closing and opening of the clutch must be clearly audible.

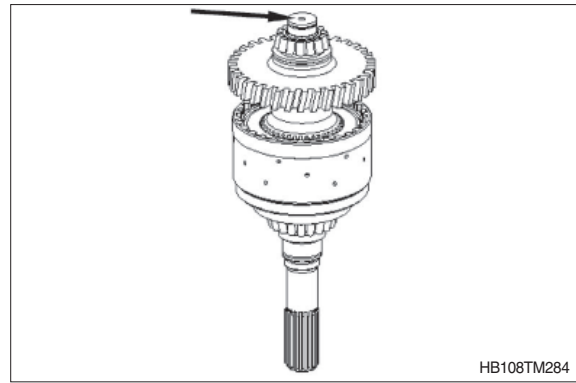

6) REINSTALLATION AND REASSEMBLY OF TRANSMISSION PUMP, OIL SUCTION TUBE AND OIL FILLER TUBE, CONTROL PRESSURE AND CONVERTER SAFETY VALVE, COARSE FILTER AND CLUTCHES

(1) Reassembly of transmission pump

※ In case of wear marks in the pump housing, stator hollow shaft, inner rotor, outer rotor and on the sliding bearing, the pump assy must be replaced.

Legend:

1 = Stator hollow shaft

2 = Inner rotor

3 = Outer rotor

4 = Pump housing with sliding bearing

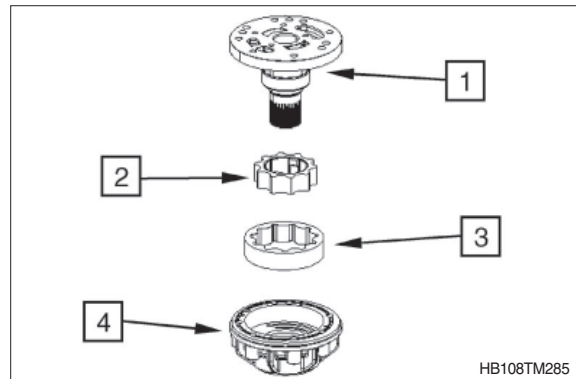

HB108TM285

② With the sealing lip showing downwards, carefully insert the shaft seal $55 \times 75 \times 8$ (1) into the pump housing (2) until contact is obtained.

※ Fill space between sealing lip and dust lip with grease.

※ **Outer diameter :**

- If rubber-coated : wet with spirit
- If made of metal : apply sealing agent loctite No. 574.

(S) Driver tool 5870 048 219

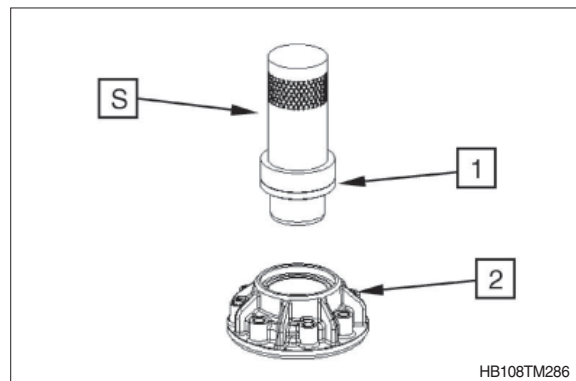

HB108TM286

③ Fit outer rotor (1) and inner rotor (2).

※ The driver pins of the inner rotor (see arrows) are to be fitted in upward direction.

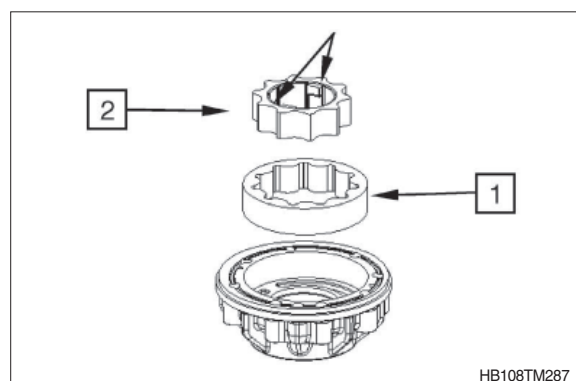

HB108TM287

- ④ Fit stator hollow shaft (1).

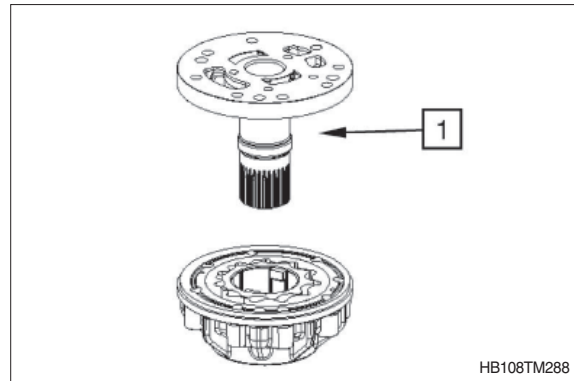

- ⑤ Fix stator hollow shaft radially with two cylindrical screws (1).

※ Do not tighten the cylindrical screws – just turn them in until contact is obtained and then turn them back by approx. 1/2 rotation.

Place O-ring (2) 135×3 into the annular groove and grease it.

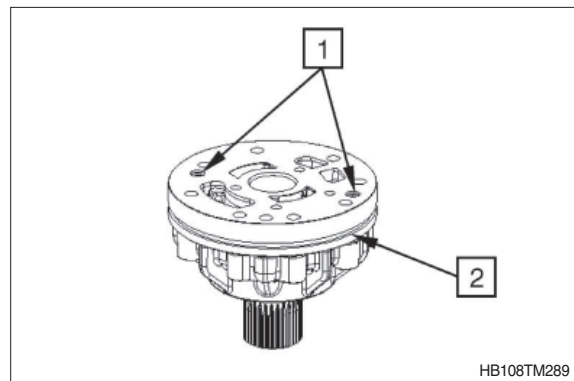

(2) Oil suction tube and oil filter tube

- ① Mount O-ring 30×3 (1) onto the suction tube (2) and grease it.

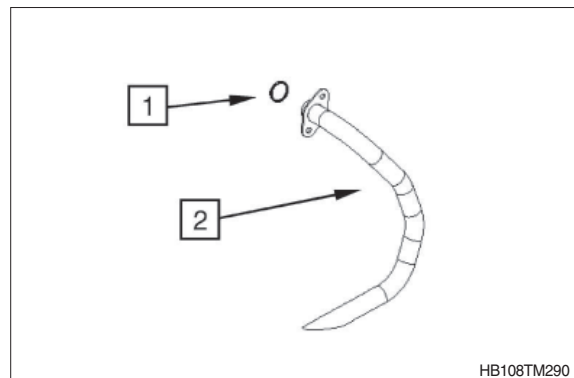

- ② Fix suction tube (1) with cylindrical screws M8×16 (2).

· Tightening torque M8/8.8×16 ;
2.35 kgf · m (17.0 lbf · ft)

※ When reusing the cylindrical screws these must be secured with loctite #243.

※ New cylindrical screws are already provided with adhesive (microcapsule). The microcapsule bursts when the screw is turned in, wets screw and nut thread and hardens.

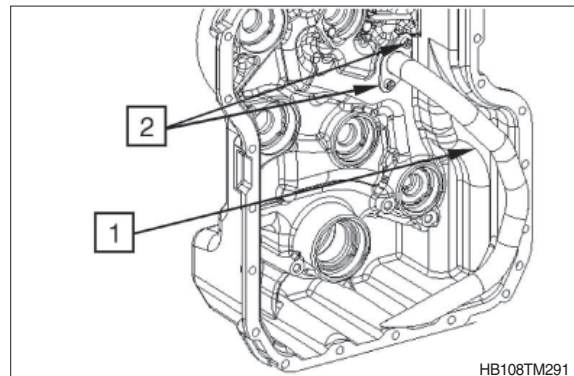

- ③ Insert tube (1) into the transmission housing by means of driver tool (S).

(S) Driver tool 5870 048 309

- ※ Use the driver tool to obtain the correct offset.

- ※ Apply loctite #574 onto the surface (A).

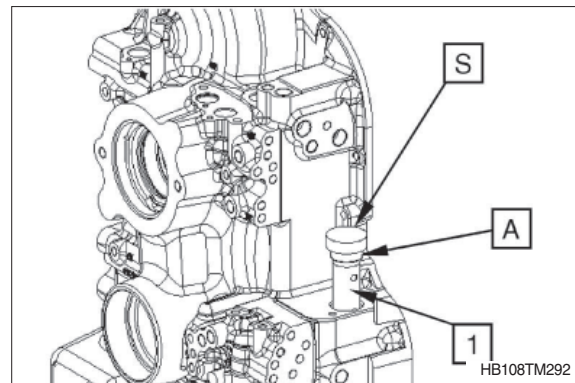

(3) Coarse filter

- ① Insert filter (1).

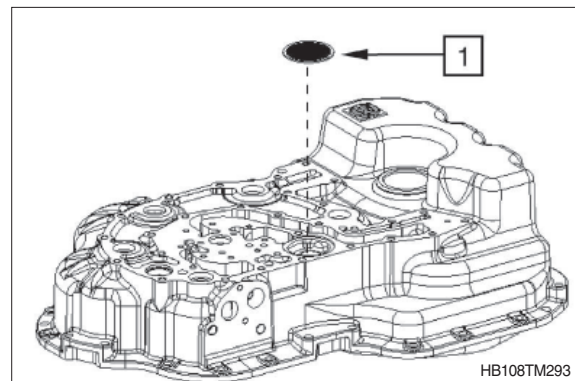

(4) Reinstallation of converter safety valve

- ① Insert valve (1) with drift (S) into the housing until contact is obtained.

(S) Drift 5870 705 012

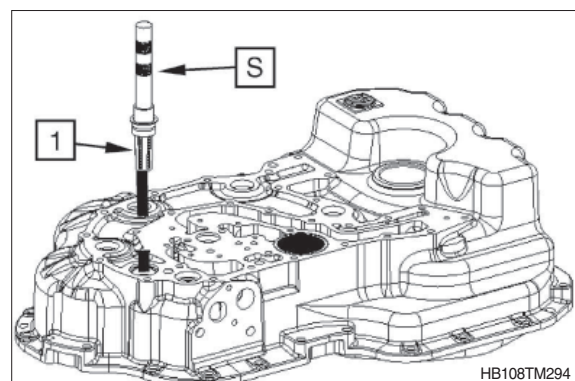

(5) Reassembly of main pressure valve (control pressure)

- ① Insert main pressure valve (1).
Main pressure valve consists of:
2 = Piston
3 = Spacer ring (2 pcs)
recommended value 5 mm
4 = Compression spring

- ※ The main pressure 16+3 bar is determined by means of the spacer rings.

- ※ Gradation of available spacer rings see spare parts list.

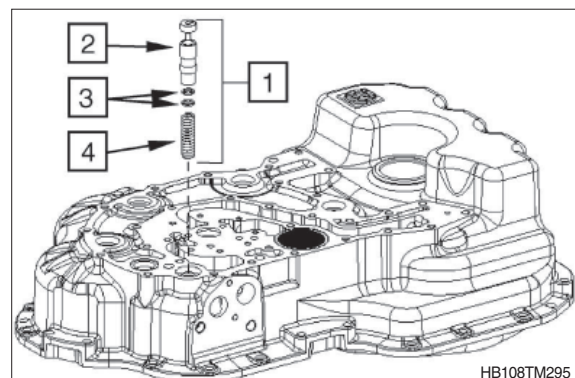

- ② Fit screw plug M22×1.5 (1) with O-ring 19×2.

· Tightening torque :

5.1 kgf · m (36.9 lbf · ft)

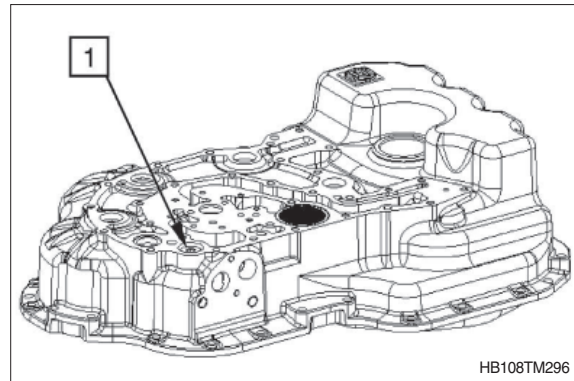

(6) Reinstallation of transmission pump

- ① Fit two adjusting screws (S) and position converter bellhousing (1) equally until contact is obtained.

※ Pay attention to the hole pattern.

※ Wet mounting face with loctite #574.

(S) Adjusting screws (M10)5870 204 007

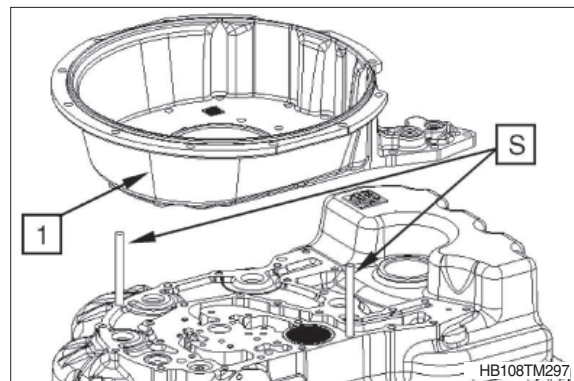

- ② Force the cylindrical pins 12×24 (1) into the holes (blind holes) until contact is obtained.

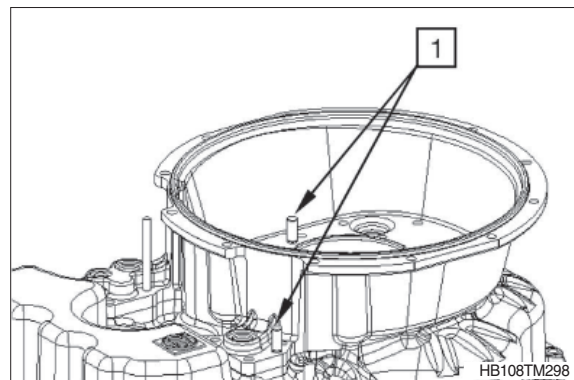

- ③ Fix converter bellhousing (1) with cylindrical screws M10×30 (2).

· Tightening torque (M10/8.8×30) ;

4.69 kgf · m (33.9 lbf · ft)

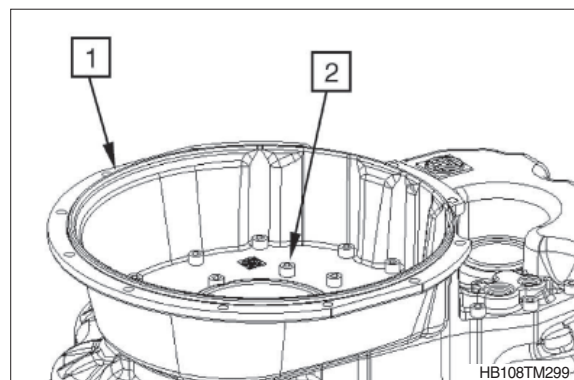

- ④ Fit two adjusting screws (S) and mount preassembled pump (1).

※ Pay attention to the hole pattern.

(S) Adjusting screws (M8) 5870 204 011

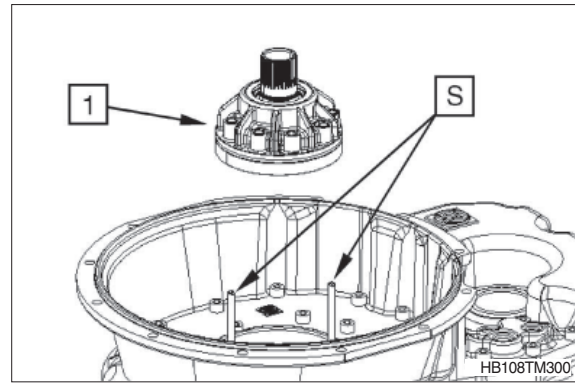

- ⑤ Position transmission pump with 3 cylindrical screws (1) M8×60 (3×120° offset position) equally until contact is obtained.

※ Do not damage (shear off) the O-ring.

- ⑥ Fix transmission pump with cylindrical screws M8x60 (1).

· Tightening torque (M8/8.8×60) ;
2.35 kgf · m (17.0 lbf · ft)

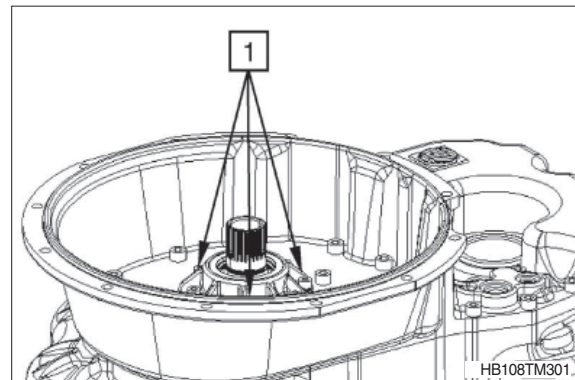

- ⑦ Fix pump with cylindrical screws (1 and 2).

1 = M8 × 16

2 = M8 × 35

· Tightening torque (M8/8.8×16) ;
2.35 kgf · m (17.0 lbf · ft)

· Tightening torque (M8/8.8×35) ;
2.35 kgf · m (17.0 lbf · ft)

※ New cylindrical screws are to be fitted on a general basis.

※ These cylindrical screws are already provided with adhesive (microcapsule). The microcapsule bursts when the screw is turned in, wets screw and nut thread and hardens.

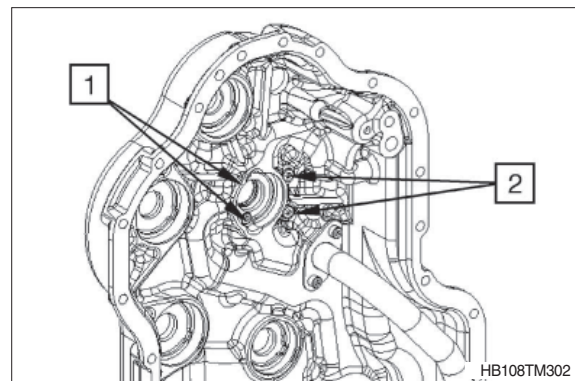

(7) Reinstallation of clutches

- ① Insert all bearing outer rings (1) into the bearing holes of both housing parts (see figures).
- ※ Place bearing outer rings into the bearing holes using assembly grease.

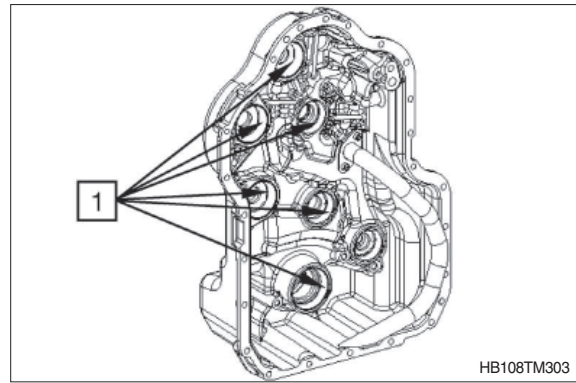

- ※ If the tapered roller bearings of clutches and input are not replaced, it is imperative to ensure the previous pairing (bearing inner ring/bearing outer ring) - see figures TM029, 030 at page 3-32.

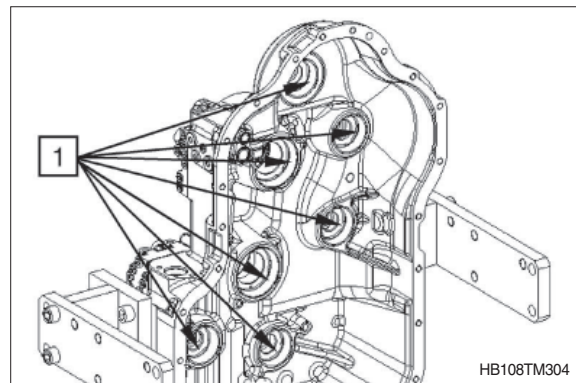

Reinstallation of K2, K3 and front wheel drive

- ② Align and grease rectangular rings 50×2.5 (4) and rectangular rings 30×2 (6), as well as those of the front wheel drive.
- ③ Hold K3 clutch (5) and front wheel drive (1) by means of the lifting device, position K2 clutch (2) and screen sheet (3) at K3 clutch (5), and then jointly insert the assembly.

(S) Eyebolts 5870 204 080

- ※ Bolts (8) of the screen sheet must be fixed into the pilot holes (7).

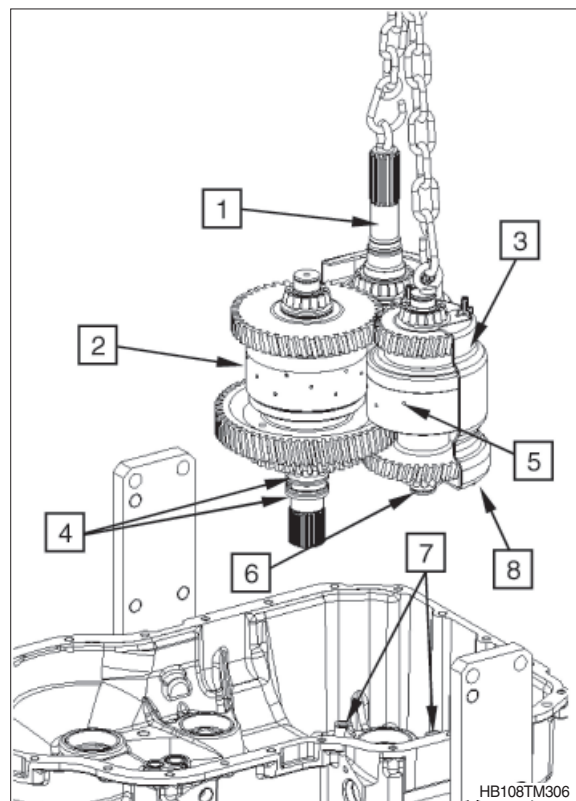

Reinstallation of K1

- ④ Align and grease rectangular ring 30×2 (2).
- ⑤ Position K1 clutch (1).

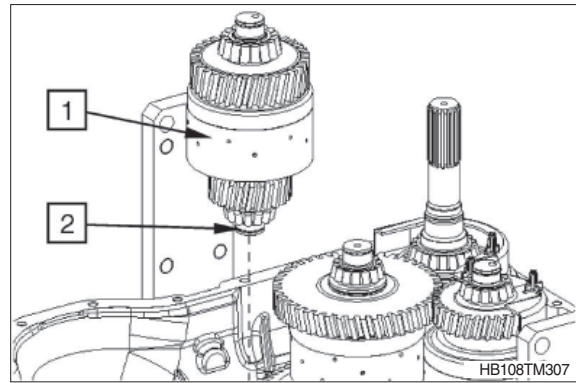

Reinstallation of KV and KR

- ⑥ Align and grease rectangular rings 50×2 (4) and rectangular ring 30×2 (3).
- ⑦ Jointly position KV clutch (1) and KR clutch (2).

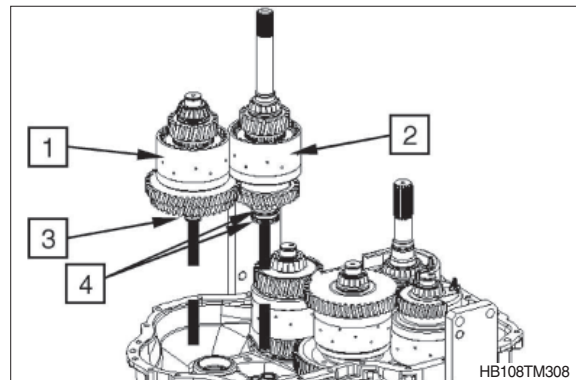

Reinstallation of K4

- ⑧ Align and grease rectangular ring 30×2 (1).
- ⑨ Position K4 clutch (2).

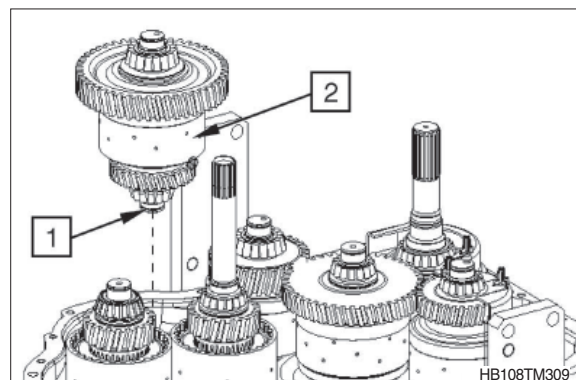

- ⑩ Place O-rings (5 and 6) into the hole and grease them. Align and grease rectangular rings (1, 2, 3, 4, 8 and 9).

- 1 = Rectangular ring 30×2 (KV clutch)
- 2 = Rectangular ring 30×2 (K4 clutch)
- 3 = Rectangular ring 35×2 (KR clutch)
- 4 = Rectangular ring 30×2 (K1 clutch)
- 5 = O-ring 15×2
- 6 = O-ring 21.89×2.62
- 7 = (front wheel drives)
- 8 = Rectangular ring 30×2 (K2 clutch)
- 9 = Rectangular ring 30×2 (K3 clutch)

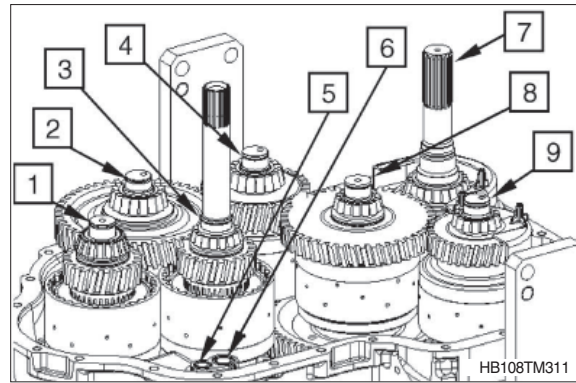

- ⑪ Use the lifting device to carefully bring the transmission housing front part into contact position.

- ※ Bolts (1) of the screen sheet must be fixed into the pilot holes.
- ※ Wet mounting face with loctite # 574.

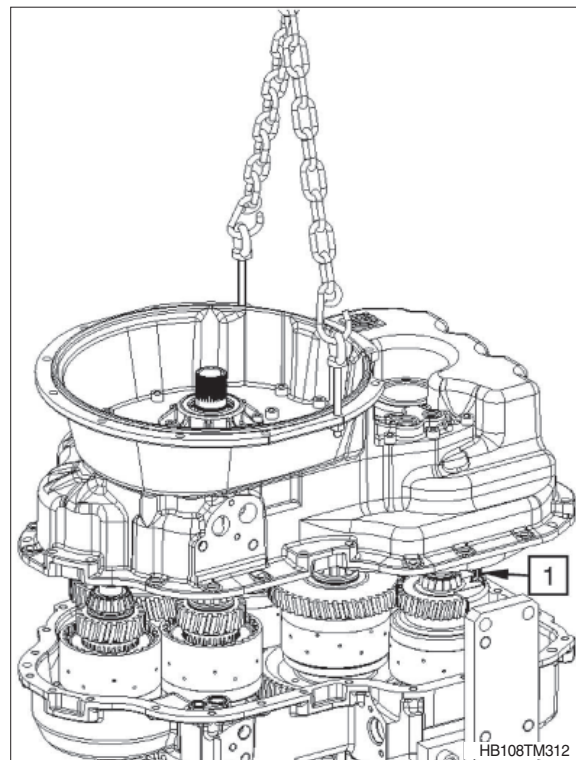

- ⑫ Hand-tighten the transmission housings crosswise with 2 cylindrical screws (1).

- ⑬ Fit cylindrical pins 12×24 (2) centrally to the mounting face.

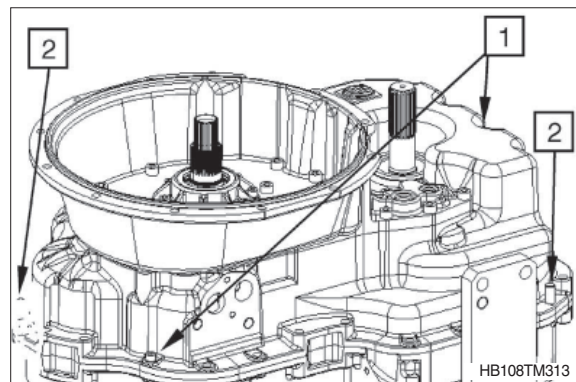

⑭ Fix transmission housing front and rear part by means of cylindrical screws (1 and 2).

⑮ Fit bracket (3).

Cylindrical screw (1) M10×30 (14 EA)

Cylindrical screw (2) M10×50 (10 EA)

- Tightening torque M10/8.8×30 ;
4.69 kgf · m (33.9 lbf · ft)
- Tightening torque M10/8.8×50 ;
4.69 kgf · m (33.9 lbf · ft)

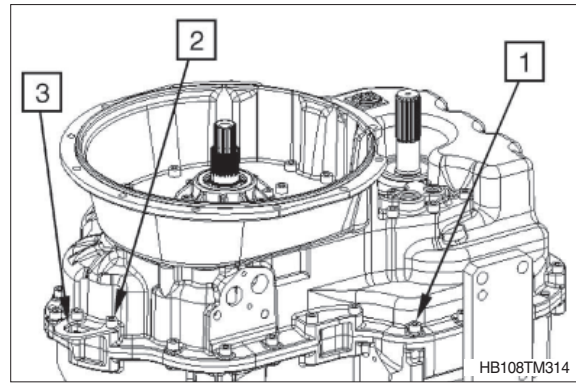

7) REASSEMBLY OF REAR AXLE OUTPUT FLANGE AND SCREW PLUG AT MEASURING POINT "63" AFTER THE CONVERTER, AND SEALING OF VERSION WITH AND WITHOUT FRONT WHEEL DRIVE

(1) Reassembly of rear axle output flange

- ① Use driver tool (S) to fit the shaft seal 60×90×8 (1) until contact position, with the sealing lip showing towards the oil sump (see figure below).

(S) Driver tool 5870 048 200

- ※ Fill space between sealing lip and dust lip with grease.
- ※ Wet rubber-coated outer diameter with spirit.
- ※ Use the driver tool to obtain the correct offset.

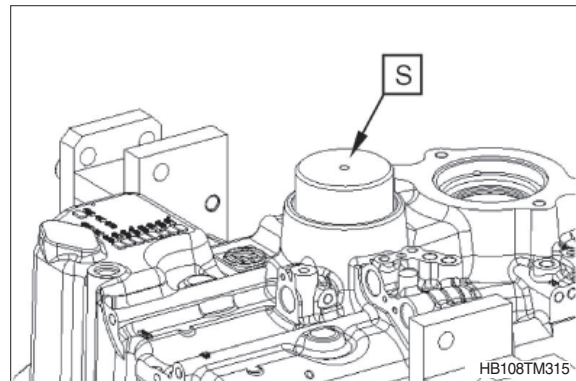

※ Installation situation - rear axle output

- 1 = Shaft seal 60×90×8
- 2 = Screen sheet
- 3 = Closing cover
- 4 = Output flange
- 5 = K2 clutch shaft
- 6 = Transmission housing

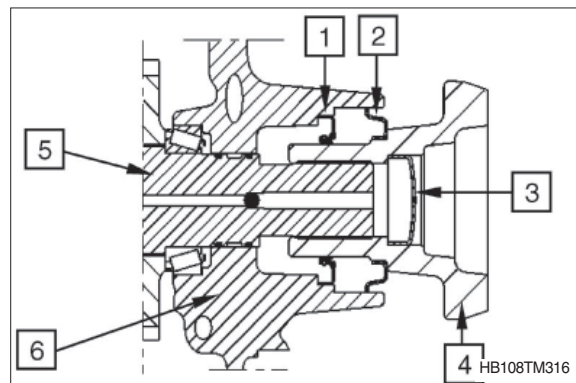

- ② Press closing cover (3) into the flange (4) until contact is obtained (see figure above).

- ※ Apply loctite #518 to the closing cover.
- ※ Use suitable pressure piece; closing cover must not be deformed.

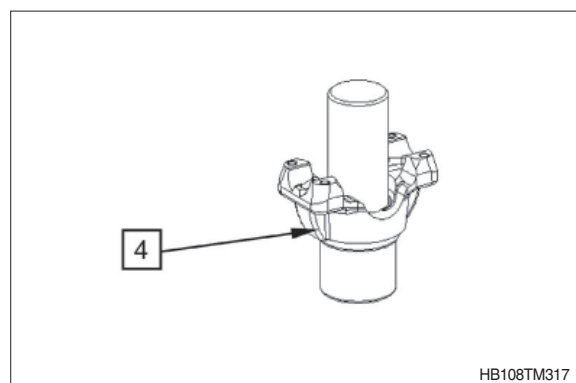

- ③ Press screen sheet (2) onto the flange (4) until contact is obtained.

※ Use suitable pressure piece; screen sheet must not be deformed.

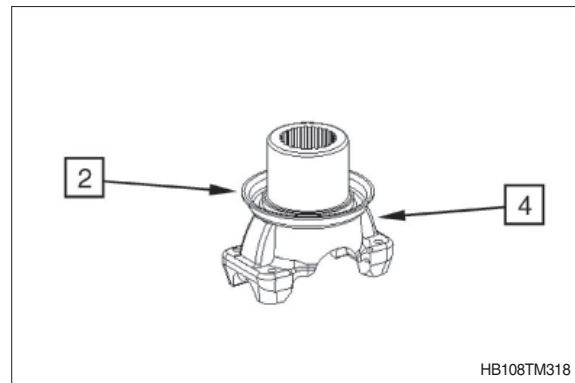

HB108TM318

- ④ Mount output flange (4) until contact position.

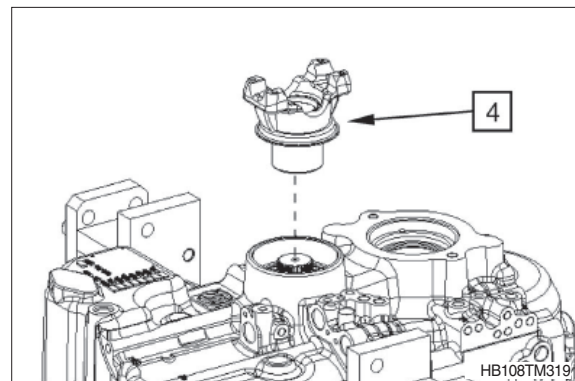

HB108TM319

(2) Sealing of front-wheel-drive

- ① Use driver tool (S) to fit the shaft seal (1) until contact position, with the sealing lip showing towards the oil sump (see figure below).

(S) Driver tool 5870 048 310

- ※ Fill space between sealing lip and dust lip with grease.
 ※ Wet rubber-coated outer diameter with spirit.
 ※ Use the driver tool to obtain the correct offset.

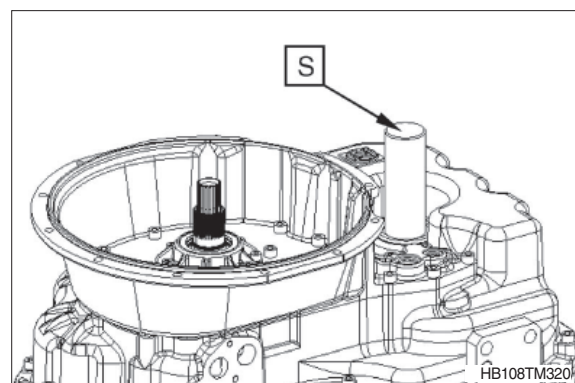

HB108TM320

Installation situation

- 1 = Shaft seal 40 × 62 × 7
 2 = Screen sheet
 3 = VA clutch shaft
 4 = Transmission housing

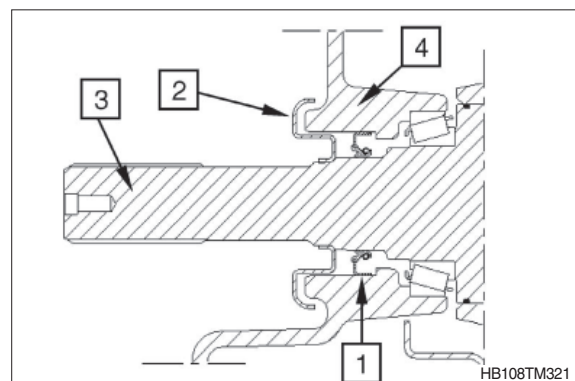

HB108TM321

8) REINSTALLATION OF NOZZLES (ORIFICES), SCREW PLUGS, SOLENOID VALVES, INDUCTIVE SENSOR AND MOUNTING PROVISION FOR OIL FILLER TUBE

(1) Reinstallation of nozzles (orifices)

- ① Fit nozzle M10×1 ϕ 1.55 (1) for the directional clutches KV, KR and K4.

· Tightening torque ;
1.02 kgf · m (7.38 lbf · ft)

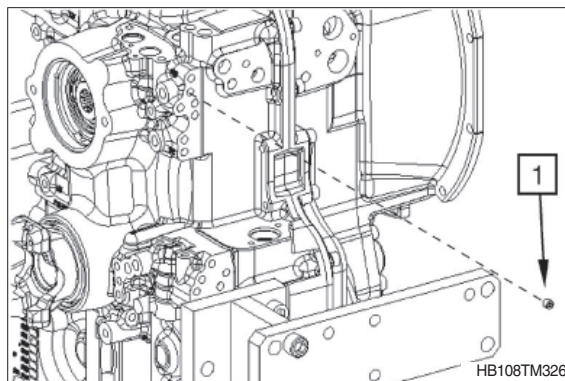

- ② Fit nozzles for the gear clutches K1, K2 and K3.

1 = Nozzle (K1)	M10×1 ϕ 1.4
2 = Nozzle (K2)	M 8 ϕ 1.7
3 = Nozzle (K3)	M 8 ϕ 1.4

· Tightening torque M8, M10×1 ;
1.02 kgf · m (7.38 lbf · ft)

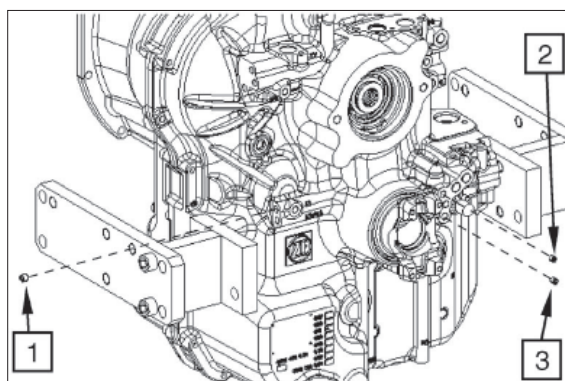

(2) Reinstallation of screw plugs

- ① Install all screw plugs with O-rings.

1 = Screw plug 3/4 -16 UNF;	
O-ring 16.36×2.21 (2 EA)	
2 = Screw plug M10×1;	
O-ring 8×1.5 (36 EA)	
3 = Screw plug 9/16 -18 UNF;	
O-ring 11.89×1.98 (3 EA)	

· Tightening torque 3/4 -16 UNF ;
2.86 kgf · m (20.7 lbf · ft)

· Tightening torque M10×1 ;
0.61 kgf · m (4.43 lbf · ft)

· Tightening torque 9/16 -18 UNF ;
1.53 kgf · m (11.1 lbf · ft)

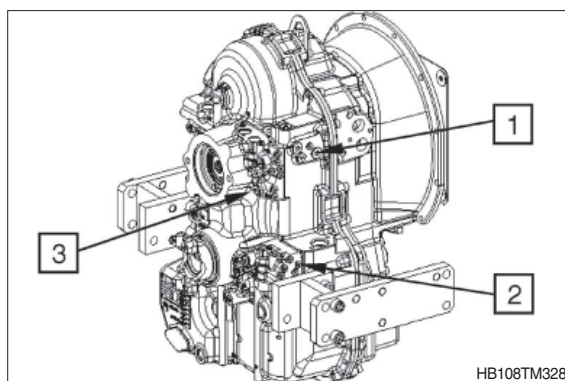

(3) Reinstallation of solenoid valves

- ① Insert solenoid valves (1 and 2) into the transmission housing and fix them by means of bracket and cylindrical screw M6×12 (3).

1 = Solenoid valve - parking brake - rear axle

2 = Solenoid valve - differential lock – rear axle

- Tightening torque M6/8.8 ;
0.97 kgf · m (7.01 lbf · ft)

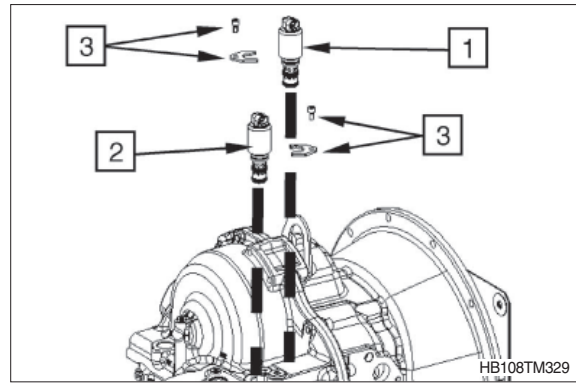

- ② Insert solenoid valve Y2 (1) into the transmission housing and fix it by means of bracket and cylindrical screw M6×12 (2).

- Tightening torque M6/8.8 ;
0.97 kgf · m (7.01 lbf · ft)

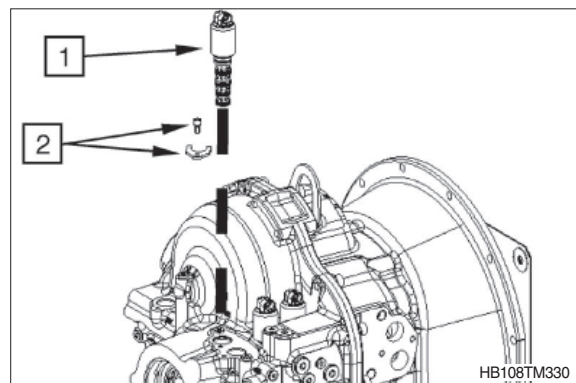

- ③ Insert solenoid valves Y1 (1) and Y3 (2) into the transmission housing and fix them by means of bracket and cylindrical screw M6×12 (3).

- Tightening torque M6/8.8 ;
0.97 kgf · m (7.01 lbf · ft)

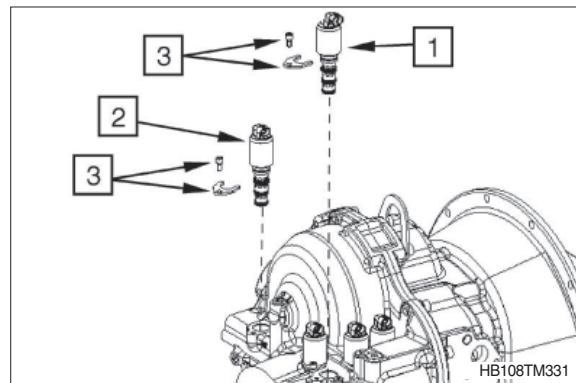

- ④ Insert solenoid valve YWD (1) into the transmission housing and fix it by means of bracket and cylindrical screw M6×12 (2).

- Tightening torque M6/8.8 ;
0.97 kgf · m (7.01 lbf · ft)

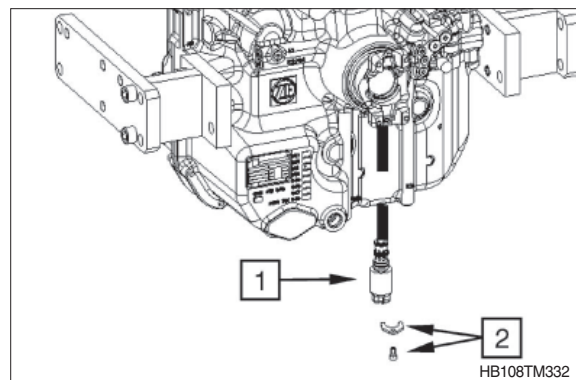

- ⑤ Insert solenoid valve Y5 (1) into the transmission housing and fix it by means of bracket and cylindrical screw M6×12 (2).

· Tightening torque M6/8.8 ;
0.97 kgf · m (7.01 lbf · ft)

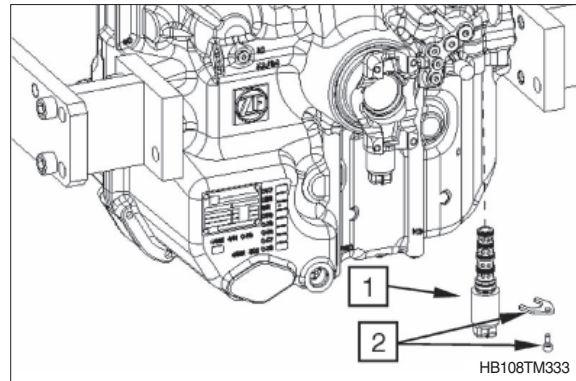

- ⑥ Insert solenoid valves Y6 (1) and Y4 (2) into the transmission housing and fix them by means of bracket and cylindrical screw M6×12 (3).

· Tightening torque M6/8.8 ;
0.97 kgf · m (7.01 lbf · ft)

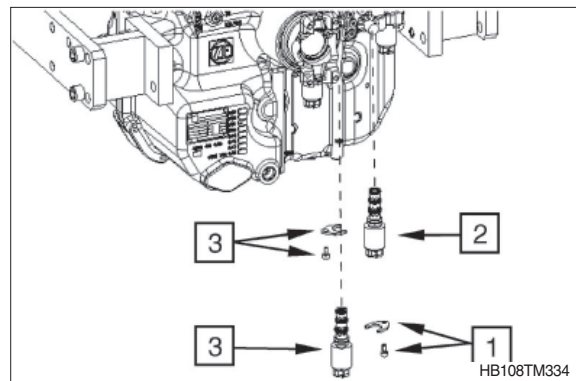

(4) Reinstallation of inductive sensor (option)

- ① Install inductive sensor (1) with O-ring 15×2 (2).

· Tightening torque ;
3.06 kgf · m (22.1 lbf · ft)

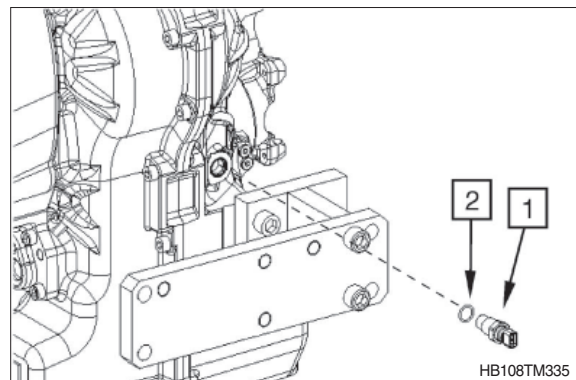

(5) Mounting provision for oil filler tube (option)

- ① Fix closing cover (2) and seal (3) with hexagon screws (1).

· Tightening torque (M8/8.8×18) ;
3.47 kgf · m (25.1 lbf · ft)

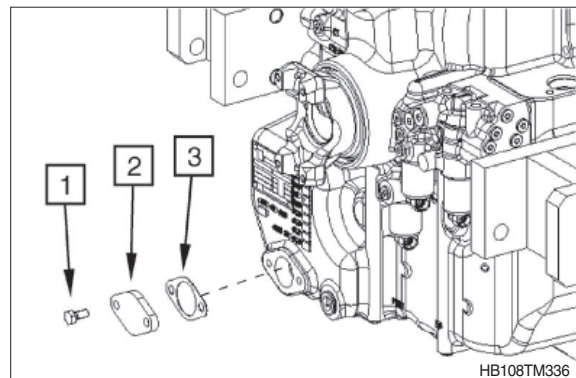

9) REASSEMBLY OF PTO

- (1) Press ball bearing $45 \times 75 \times 16$ (1) onto the pump shaft (2) until contact is obtained.
- (2) Fit rectangular ring 50×2.5 (3).
- (3) Grease and centrally align rectangular ring.

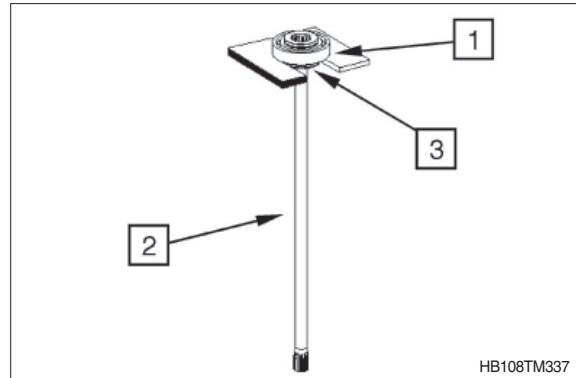

- (4) Mount pump shaft (2) until contact is obtained and fix it by means of retaining ring 75×2.5 (1).

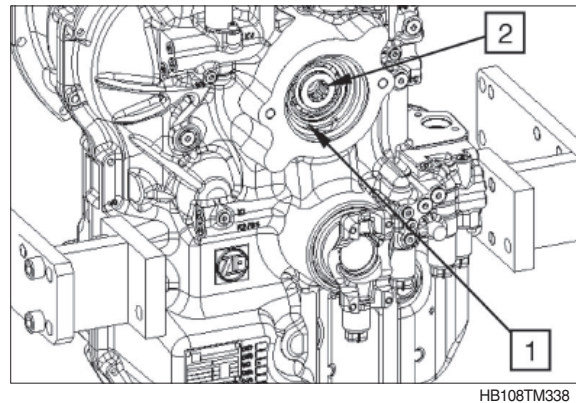

10) REASSEMBLY OF ENGINE CONNECTION

- (1) Mount converter (1) until contact is obtained.

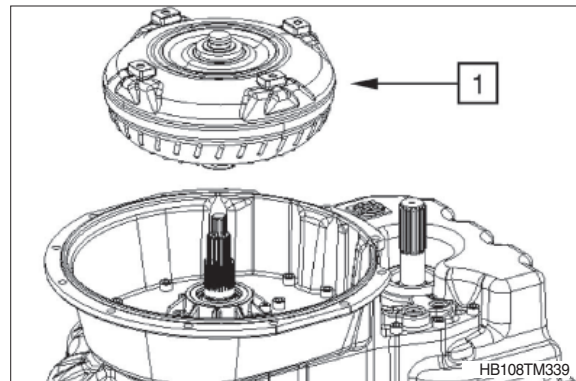

- (2) Position 1 washer/each / thickness=1.0 mm (4 EA) (1) onto the flexplate mounting webs (4 EA).

- (3) Place flexplates (2).

※ Pay attention to the installation position! Spot-welded reinforcing disks of the flexplate to be arranged towards the outside - see arrows.

- (4) Mount washer (3) onto the hexagon screw $M10 \times 16$ (4) and fix flexplates.

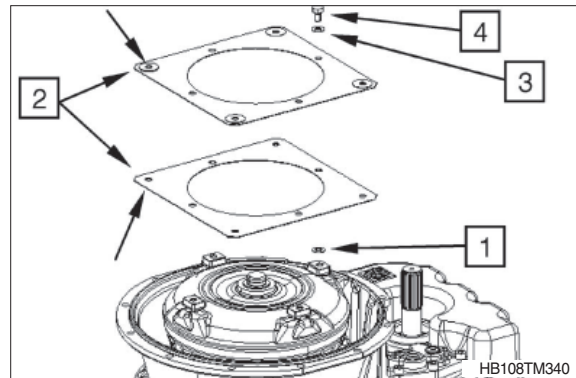

(5) Tighten hexagon screws (1).

- Tightening torque (M10/8.8×16) ;
4.69 kgf · m (33.9 lbf · ft)

- ※ When reusing the hexagon screws these must be secured with loctite 243.
- ※ New hexagon screws are already provided with adhesive (microcapsule). The microcapsule bursts when the screw is turned in , wets screw and nut thread and hardens.

Fix converter axially.

Risk of injury.

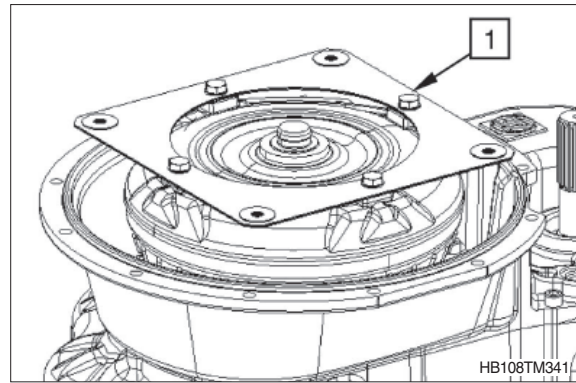

11) REASSEMBLY OF FILTER AND OIL DRAIN PLUG

(1) Place O-rings 34.2×3 (1) into the holes and grease them.

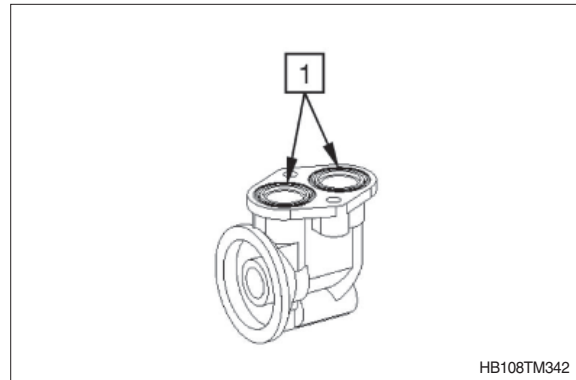

(2) Attach filter head (1) with cylindrical screws M8×30 (2).

- Tightening torque (M8/8.8×30) ;
2.35 kgf · m (17.0 lbf · ft)

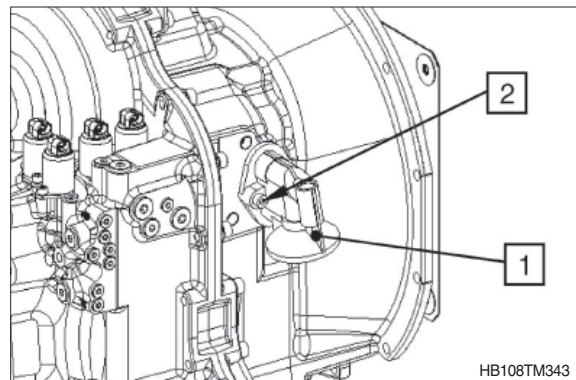

※ The filter (1) has to be fitted as follows:

- Slightly oil the seal
- Turn in the filter until contact with the sealing surface is obtained, and then tighten it by hand with approx. 1/3 to 1/2 rotation.

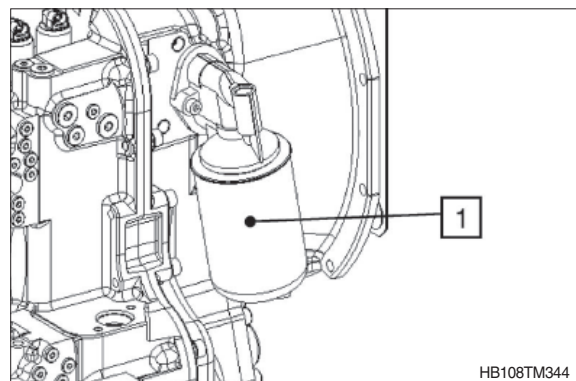

(3) Fit oil drain plug 7/8-14 UN 2A (1).

- Tightening torque (7/8-14 UN 2A) ;
3.06 kgf · m (22.1 lbf · ft)

(4) Fix identification plate (2) by means of 4 grooved pins 3 × 5.

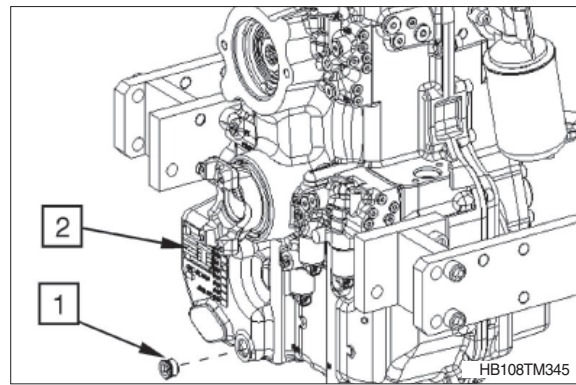

※ Before putting the transmission into operation, fill it with specified oil (SAE 15W-40).

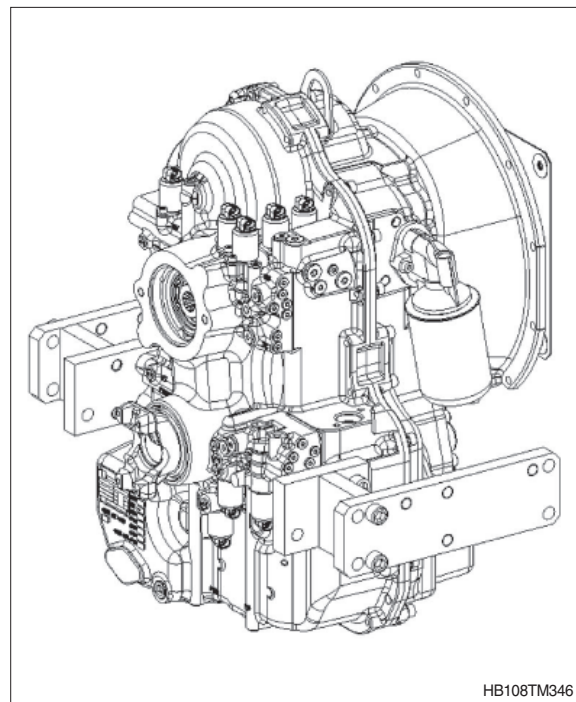

2. FRONT AXLE

1) DISASSEMBLY OUTPUT

(1) Fix the axle to the assembly truck.

(S) Assembly truck	5870 350 000
(S) Fixtures	5870 350 139
(S) Fixing bracket	5870 350 140



(2) Loosen the screw plug and drain oil from the axle.

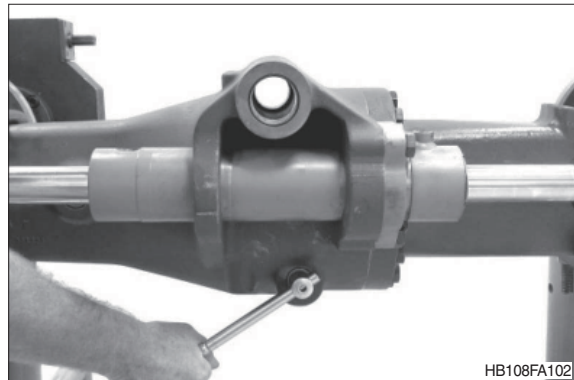

(3) Loosen the screw plug and drain oil from the planetary carrier.

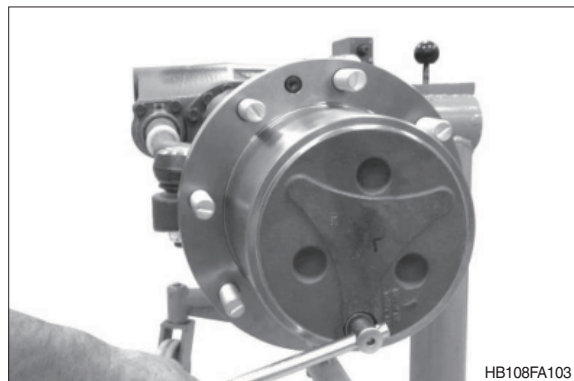

(4) Loosen the cylindrical screws and pull the planetary carrier from the hub.

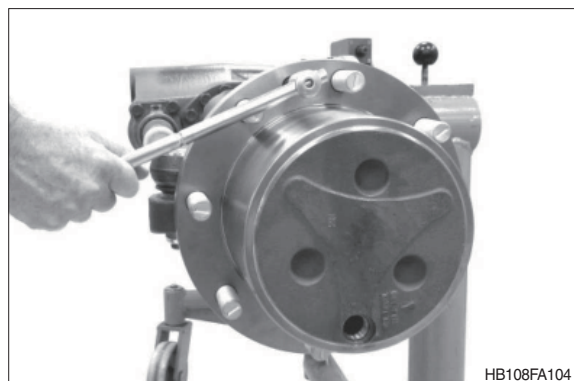

(5) Disengage the retaining ring.

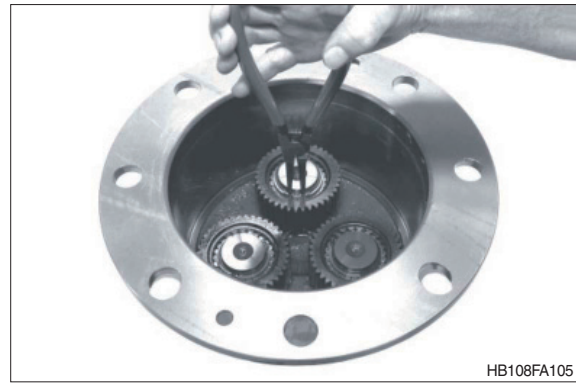

(6) Pull off the planetary gear with the cylindrical roller bearing.



(7) Loosen the locking screws.

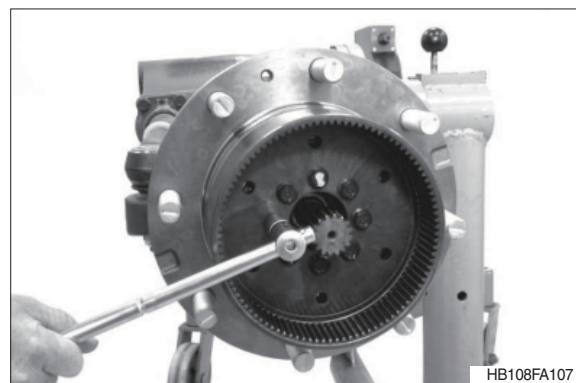

(8) Pull the ring gear with a three-armed puller from the knuckle housing/from the bushes.

(S) Pressure piece 5870 100 080

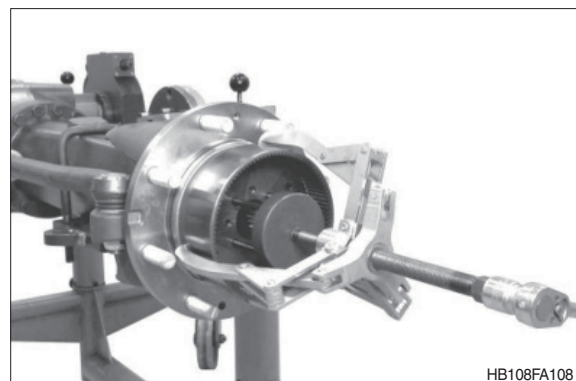

(9) Pull the hub with a two-armed puller from the knuckle housing.

(S) Pressure piece 5870 100 080

※ Pay attention to the releasing bearing inner ring.

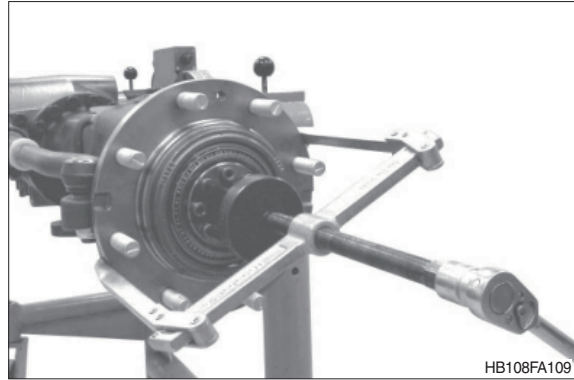

(10) Force the cassette type sealing out of the hub.



(11) Force both bearing outer rings out of the hub and remove the O-ring (see arrow).

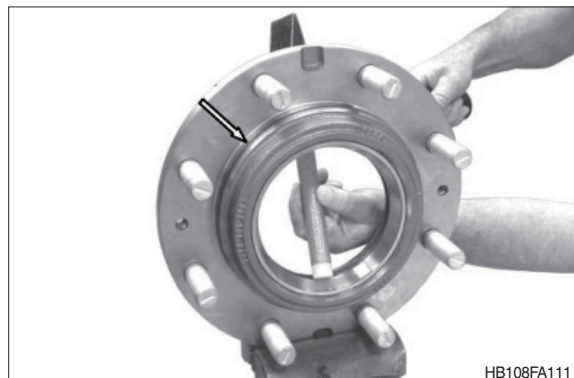

(12) Pull the bearing inner ring from the knuckle housing.

(S) Rapid grip 5873 013 015

(S) Pressure piece 5870 100 080

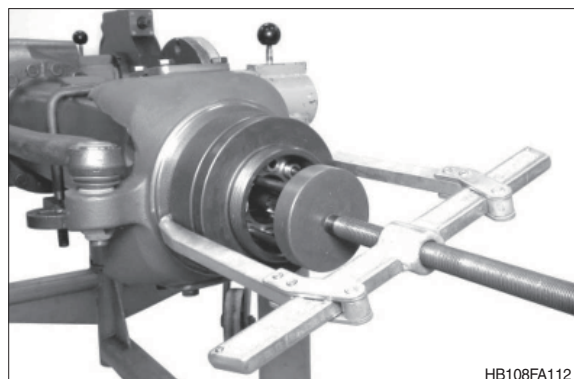

(13) Loosen the hexagon nut.

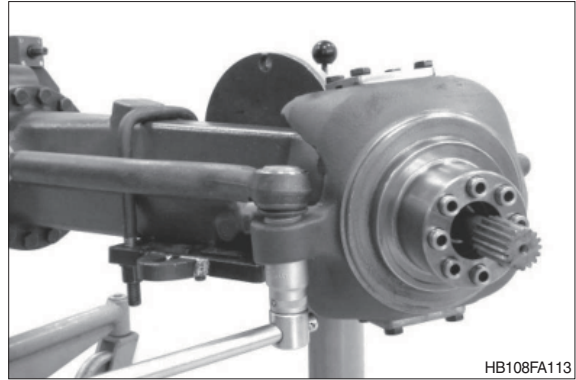

(14) Press the tie rod with a forcing device (S) out of the knuckle housing.

(S) Forcing device 5870 080 041

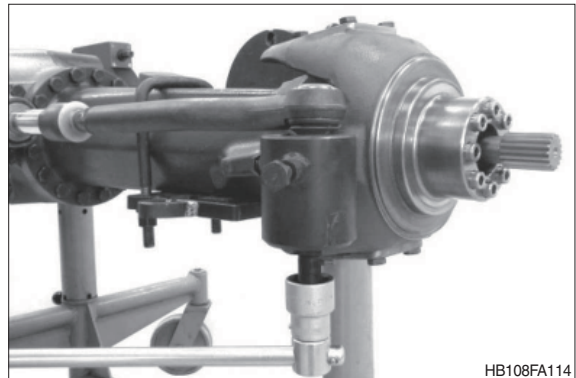

(15) Loosen the hexagon screws on both bearing bolts.

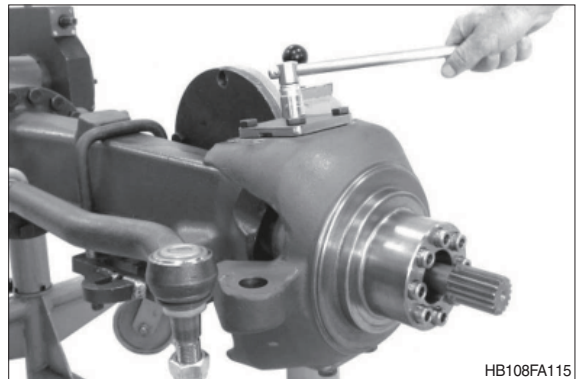

(16) Use a lever to remove both bearing bolts from the knuckle housing.

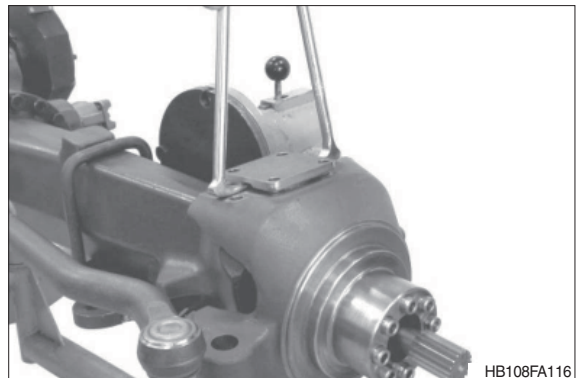

(17) Press the bearing inner ring and the shaft seal ring with the cutoff device (S) from the bearing bolt.

(S) Cut-off device 5870 300 024

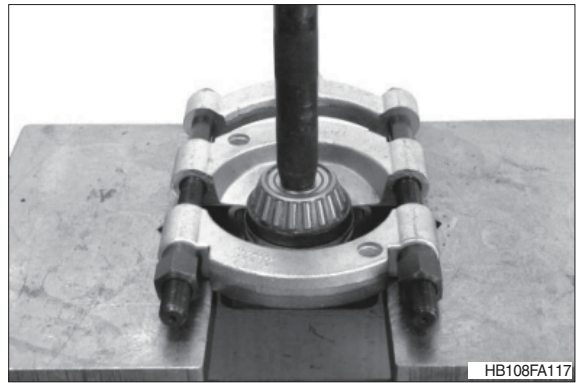

(18) Separate the knuckle housing with the double U-joint shaft from the axle housing.

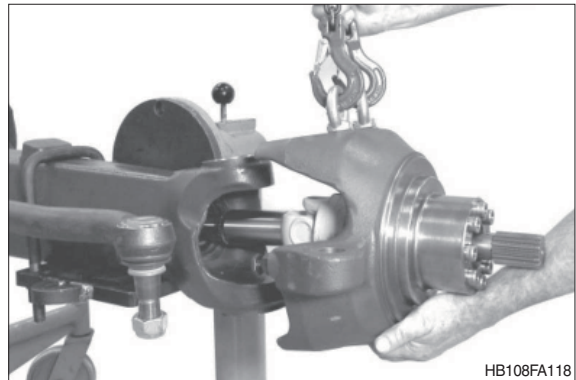

(19) Force the retaining ring apart and pull the sun gear shaft from the double U-joint shaft.

(S) Pliers 5870 900 026

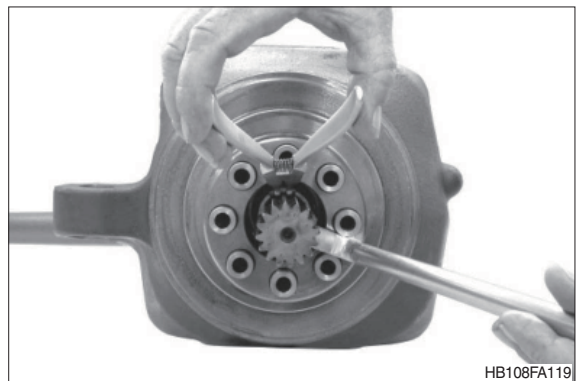

(20) Disengage the retaining ring out of the annular groove of the double U-joint shaft.

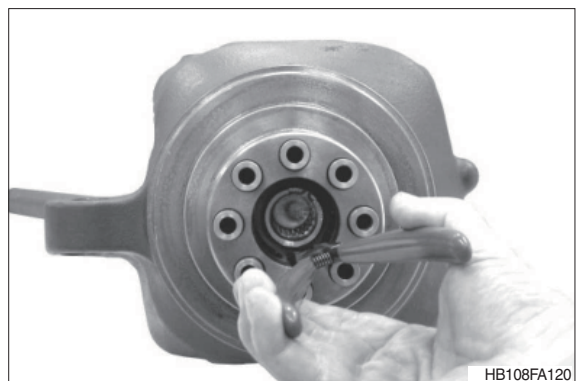

(21) Press the double U-joint shaft out of the knuckle housing.

(S) Extracting tool 5870 000 017

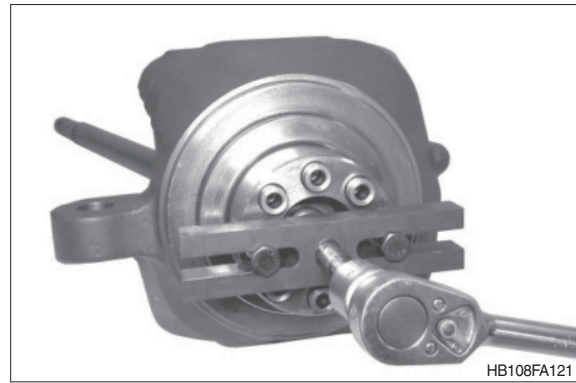

(22) Pull the shaft seal out of the housing hole.

(S) Internal extractor 5870 300 007

(S) Counter support 5870 300 003



(23) Disengage the retaining ring and press the releasing ball bearing out of the knuckle housing.



(24) If necessary provide the bushes with threads (M12) and use a striker (S) to pull them out of the housing.

(S) Striker 5870 650 001



(25) Pull both bearing outer rings out of the pivot bearing holes.

(S) Internal extractor 5870 300 007

(S) Counter support 5870 300 003

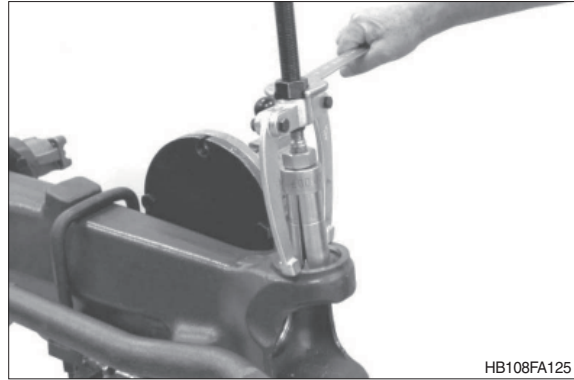

(26) Pull shaft seal and bush out of the axle housing.

(S) Internal extractor 5870 300 007

(S) Counter support 5870 300 003

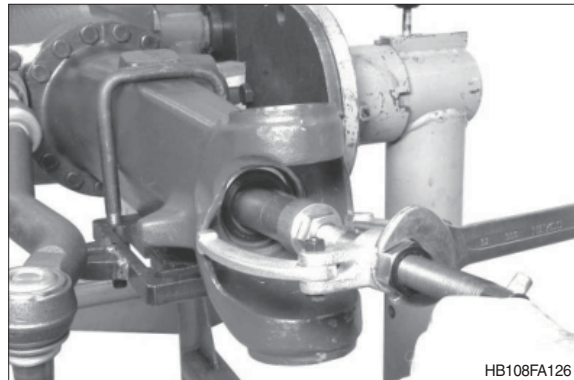

2) DISASSEMBLY STEERING

(1) Heat the piston rod with a hot air blower.

▲ The axial joint is mounted with loctite #243.

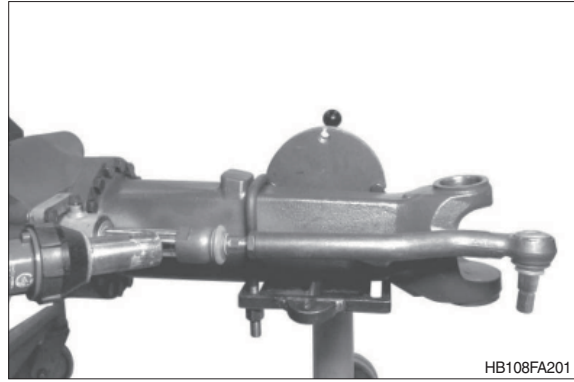

(2) Separate the tie rod from the piston rod.

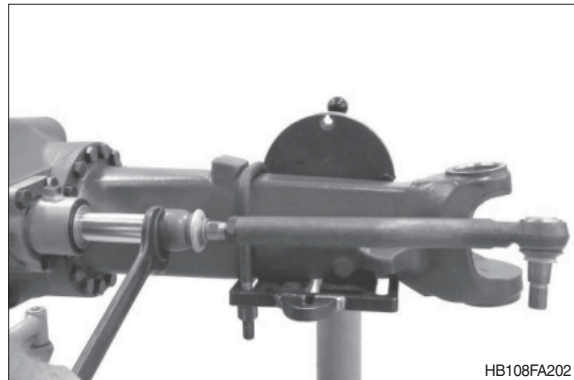

(3) Loosen the hexagon screws.

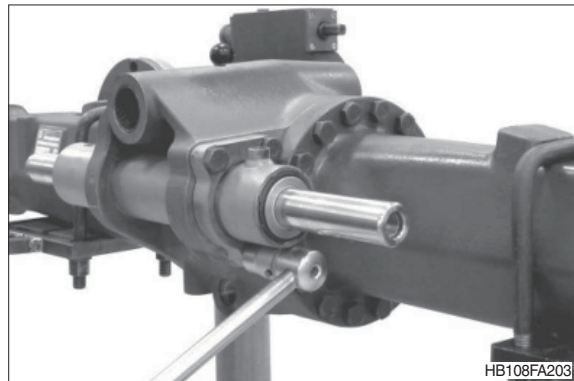

(4) Force the complete steering cylinder out of the axle housing holes.

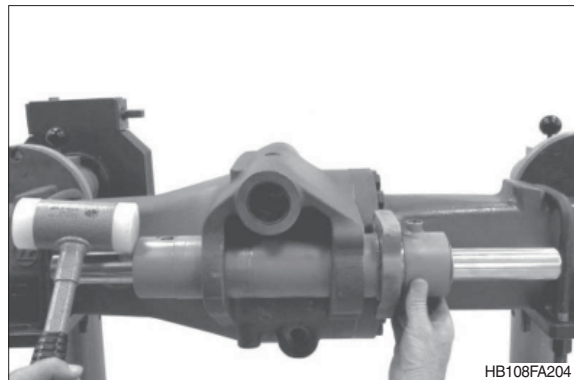

(5) Unsnap the ring and remove the releasing flange.

(S) Pliers

5870 900 026

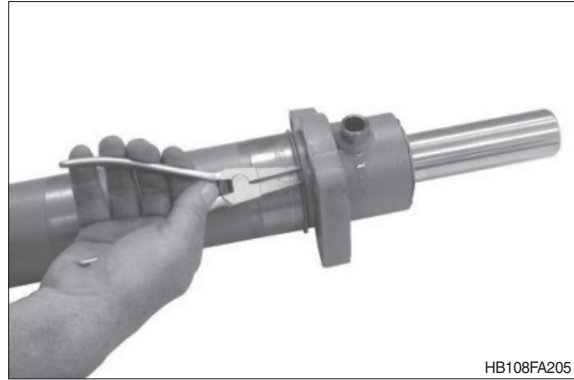

(6) Unsnap the retaining ring.



(7) Push or force the plug into the cylindrical tube, until it is possible to unsnap the retaining ring (see sketch below).



(8) Comment on sketch

1 = Cylindrical tube

2 = Retaining ring

3 = Plug

4 = Piston rod

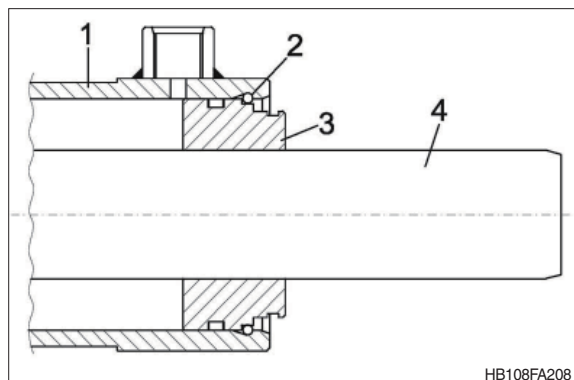

(9) Unsnap the retaining ring.



(10) Force the piston rod with the plug out of the cylindrical tube.
Then remove all sealing elements from piston rod, plug and cylindrical tube.

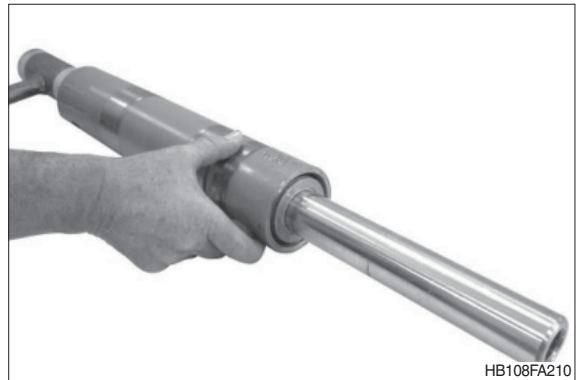

3) DISASSEMBLY INPUT

- (1) Secure the axle housing with the lifting device and loosen the screw joint. Then separate the axle housings.

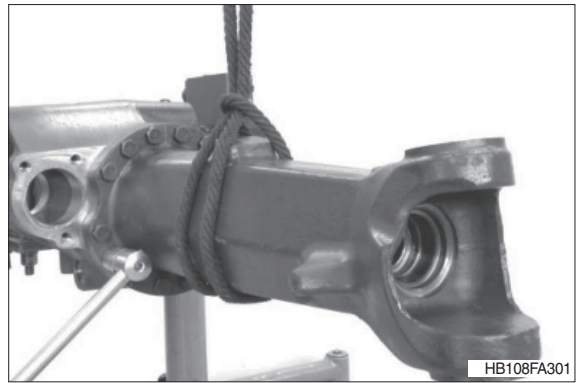

- (2) Pull the bearing outer ring with a striker out of the bearing hole and remove the shim lying behind. Remove the O-ring (see arrow).

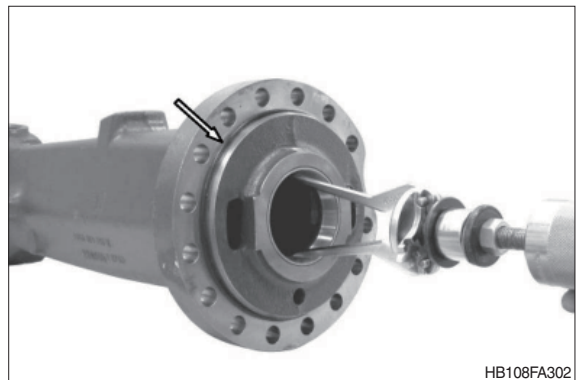

- (3) Lift the differential out of the axle housing.
※ The disassembly of the differential is described from page 3-129.

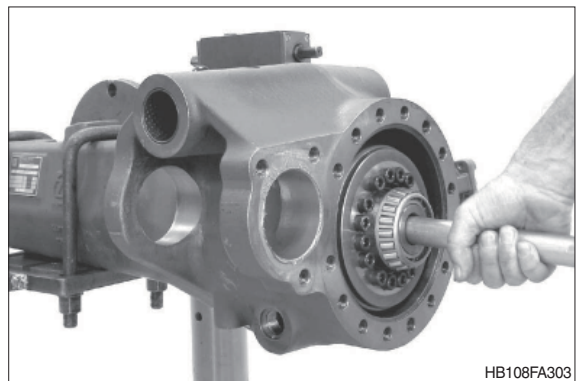

- (4) Pull the bearing outer ring with a striker out of the bearing hole and remove the shim lying behind.

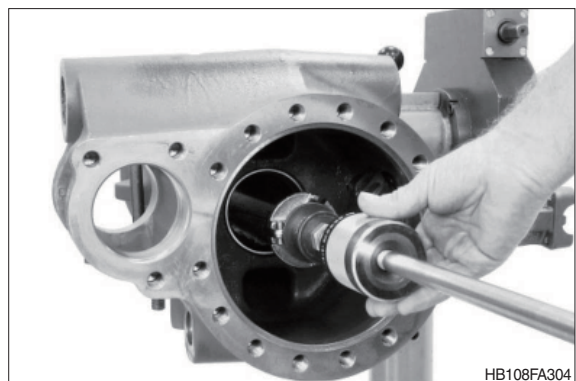

(5) Loosen the hexagon nut and remove the shim lying behind.

(S) Clamping fork 5870 240 025

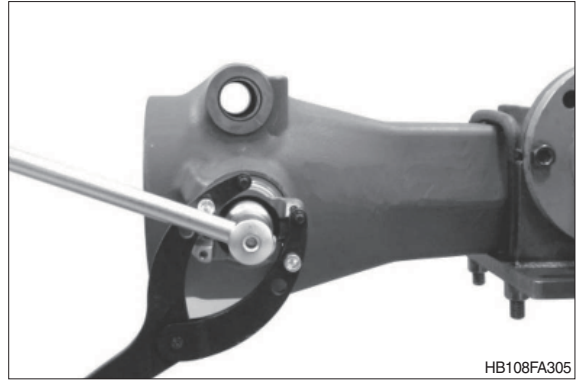

(6) Pull the yoke from the input pinion.

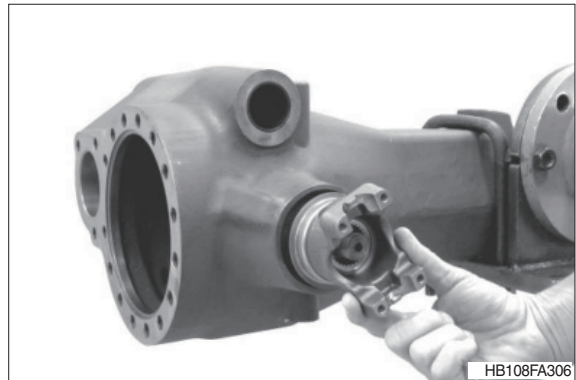

(7) Press the screen sheet with the cut-off device (S) from the yoke.

(S) Cut-off device 5870 300 024

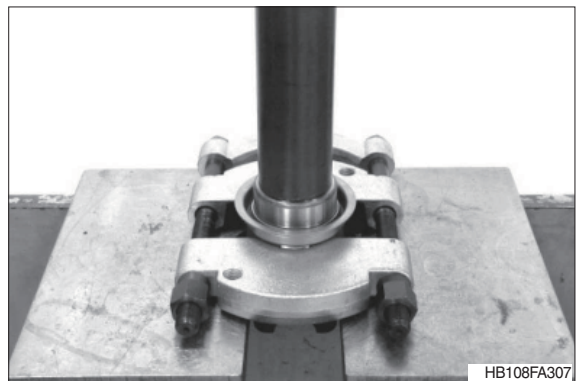

(8) Force the input pinion out of the axle housing.

※ If the pinion bearing should not be replaced, special care must be taken that the outer bearing inner ring is always in contact position with the bearing outer ring when forcing the input pinion out.

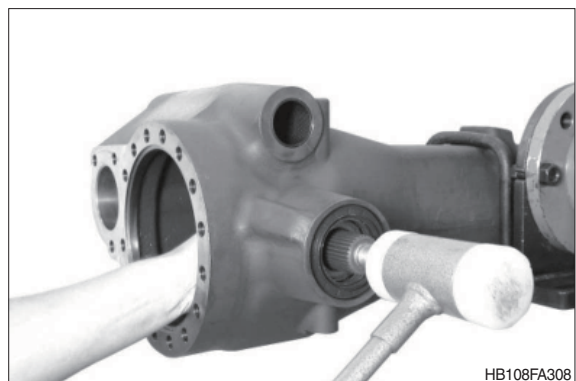

(9) Remove spacer ring and bush.



(10) Pull the roller bearing from the input pinion and remove the releasing shim.

(S) Grab sleeve 5873 001 031

(S) Basic device 5873 001 000



(11) Use a lever to remove the shaft seal ring from the axle housing and remove the releasing roller bearing.

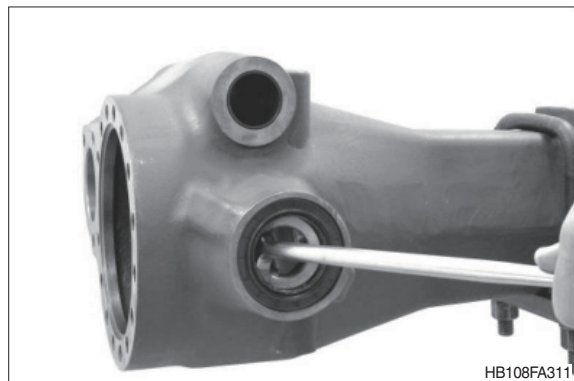

(12) Pull the bearing outer ring out of the outer bearing hole.

(S) Internal extractor 5870 300 019

(S) Counter support 5870 300 020

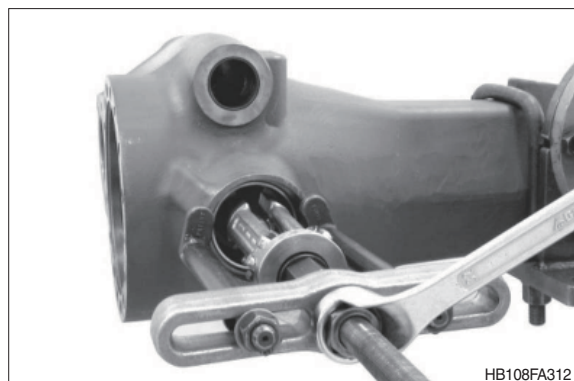

(13) Force the bearing outer ring out of the inner bearing hole.

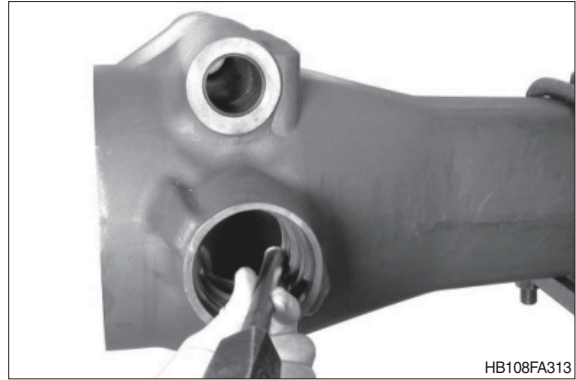

(14) If necessary, pull both bushes out of the axle housing.

- (S) Internal extractor 5870 300 005
- (S) Counter support 5870 300 003

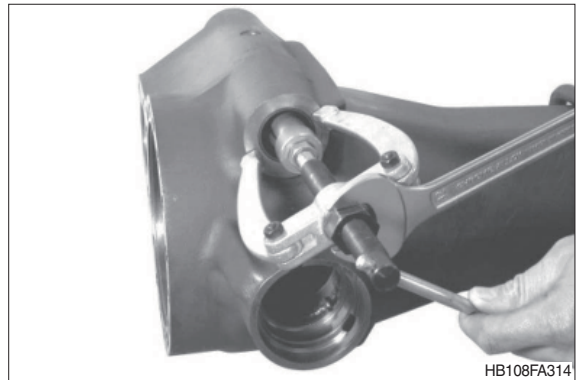

4) DISASSEMBLY DIFFERENTIAL

(1) Pull both roller bearings from the differential carrier.

(S) Grab sleeve 5873 001 020

(S) Basic device 5873 001 000



(2) Use a press to fix the differential and loosen the cylindrical screws.

※ Cylindrical screws are mounted with loc-tite #243.

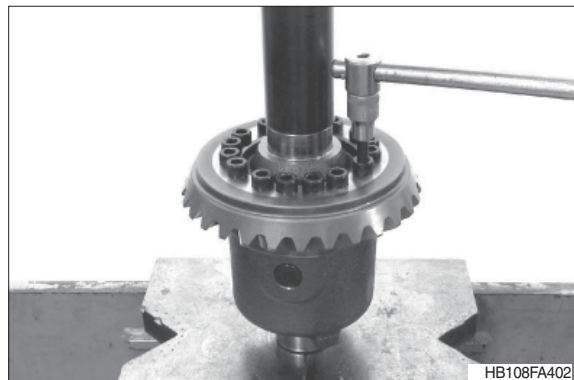

(3) Press crown wheel from differential carrier and cover.

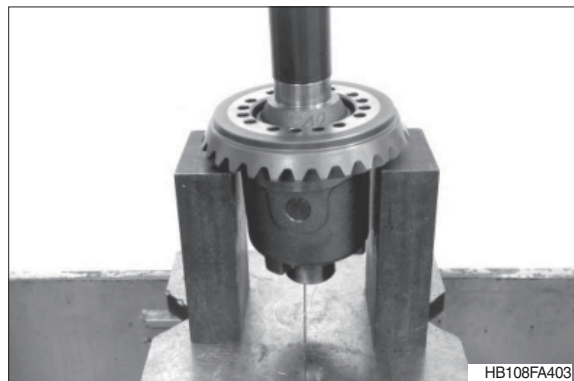

(4) Lift the axle bevel gear with thrust washer and constant spacer out of the differential carrier.



- (5) Insert the slotted pin into the differential shaft until contact is obtained.



- (6) Pull the differential shaft out of the housing and remove the releasing single parts.
Then force the slotted pin out of the differential shaft.



5) REASSEMBLY OF DIFFERENTIAL

(1) Preassemble the single parts as shown on the right sketch.

- 1 = Axle bevel gear
- 2 = Thrust washer
- 3 = Constant spacer

※ Oil all single parts with axle oil.

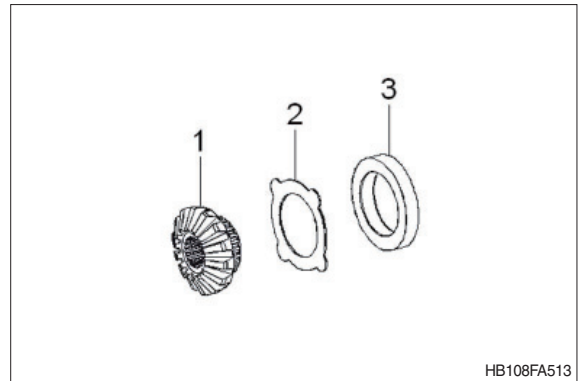

(2) Insert the preassembled axle bevel gear into the differential carrier.

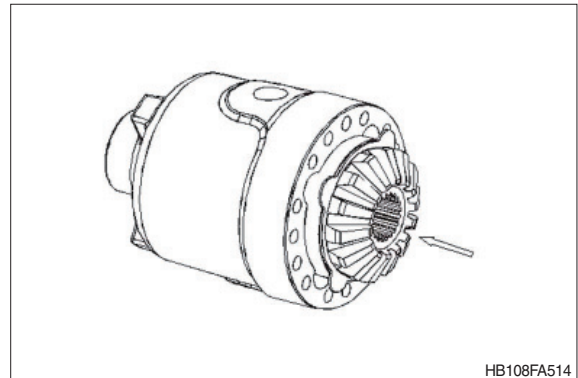

(3) Insert both axle bevel gears with thrust washers into the differential carrier and fix them with the differential shaft.

※ Pay attention to the radial installation position of thrust washers and differential shaft.



(4) Fix the differential shaft with a slotted pin.

※ Pay attention that the installation depth of differential carrier and differential shaft (see sketch (5)) is the same.



(5) Comment on sketch:

1 = Differential carrier

2 = Slotted pin

3 = Differential shaft

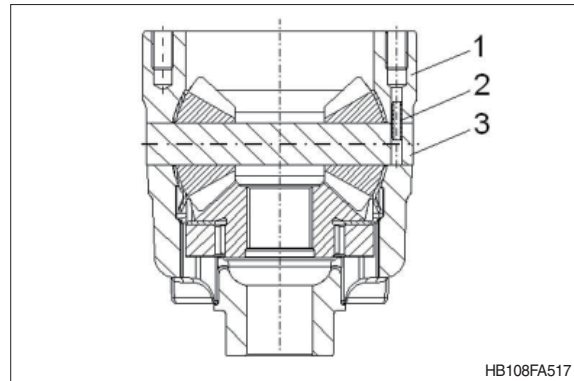

(6) Preassemble the second axle bevel gear.

1 = Axle bevel gear

2 = Thrust washer

3 = Constant spacer

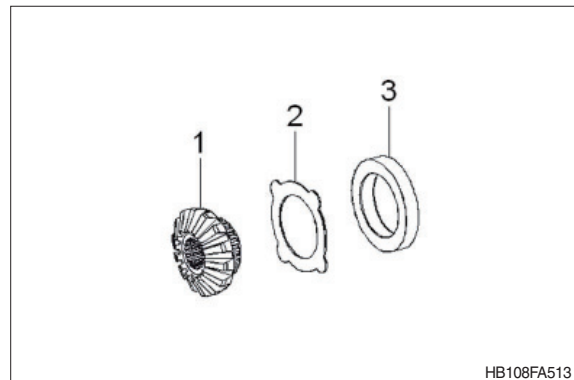

(7) Insert the preassembled axle bevel gear into the differential carrier.

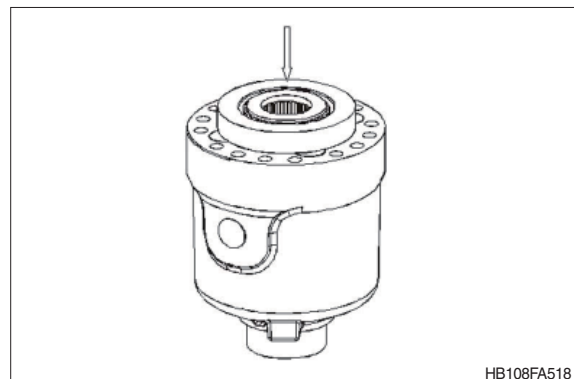

(8) Mount two adjusting screws (S) and install the cover.

(S) Adjusting screws 5870 204 007



(9) Heat the crown wheel and mount until contact position with the differential carrier is obtained.

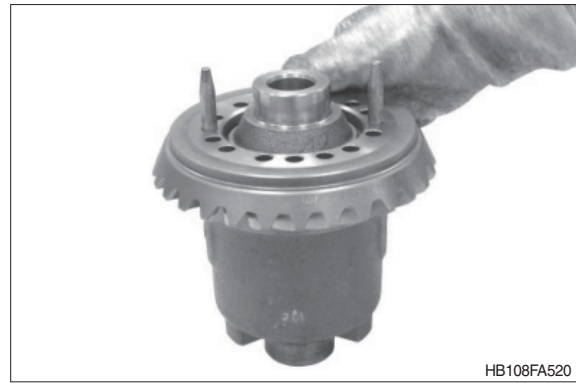

(10) Use a press to fix the differential and fix the crown wheel with cylindrical screws.

- Tightening torque (M10/10.9) :
6.93 kgf · m (50.2 lbf · ft)

※ Wet the thread of the cylindrical screws with loctite #243.

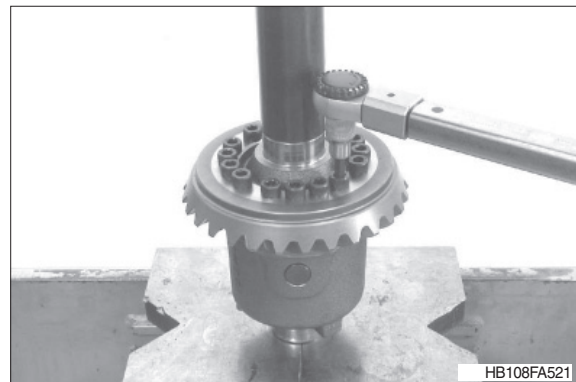

(11) Heat both roller bearings and mount them until contact is obtained.

※ Adjust the bearing after cooling down.



6) REASSEMBLY INPUT

※ If crown wheel or input pinion are damaged, both parts must be replaced together. When reinstalling a complete bevel gear set, pay attention that input pinion and crown wheel have identical mating numbers.

(1) Installation of input pinion

- ① Undercool the outer bearing outer ring (see arrow) and use the assembly fixture (S) to bring it into contact position with the bearing hole.

(S) Assembly fixture 5870 345 049
(S) Pressure rings 5870 345 056

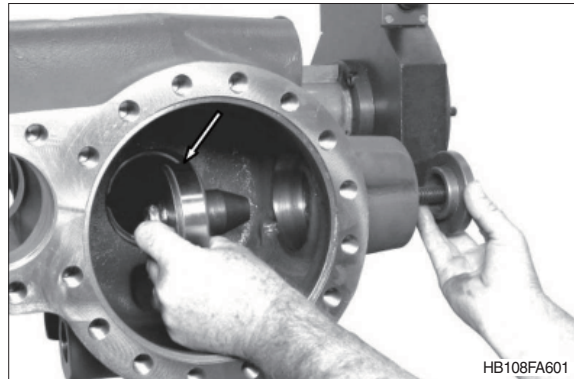

- ② Undercool the bearing outer ring and insert until contact position with the bearing hole is obtained.

(S) Driver tool 5870 058 062
(S) Handle 5870 260 002



Determine the thickness of the shim to obtain a correct contact pattern

※ Perform the following measuring operations with utmost accuracy. Inaccurate measurements result in a defective contact pattern and require to disassemble and reassemble the input pinion one more time.

① Read dimension I on the axle housing.
Dimension I e.g. 130.55 mm

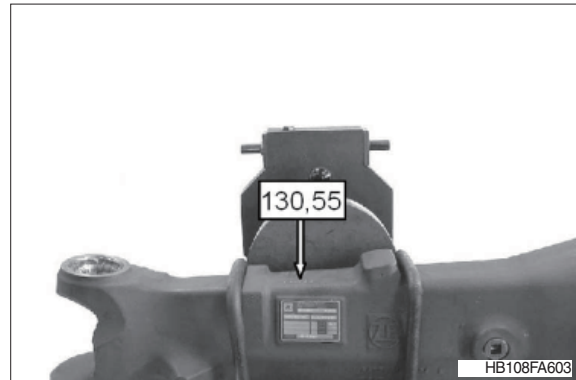

② Read dimension II (pinion dimension)
Dimension II e.g. 97.00 mm



③ Determine dimension III (bearing width).
Dimension III e.g. 30.35 mm

Calculation example A :

Dimension II 97.00 mm
Dimension III + 30.35 mm
Leads to X = 127.35 mm

Calculation example B :

Dimension I 130.55 mm
Dimension X - 127.35 mm
Difference = shim s = 3.20 mm

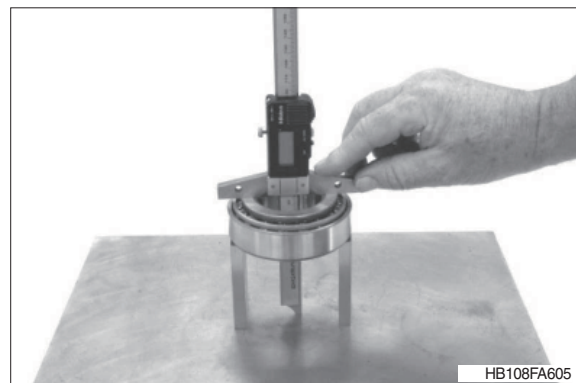

④ Insert the determined shim e.g. s = 3.20 mm.



- ⑤ Heat the roller bearing and mount until contact is obtained.
- ※ Adjust the bearing after cooling down.

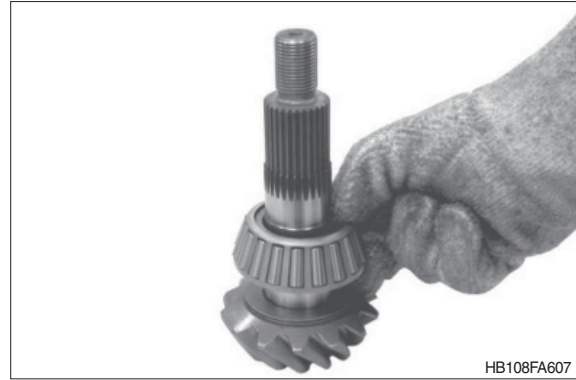

Setting of the rolling torque of the input pinion bearing 0.1~0.31 kgf · m (without shaft seal ring)

- ① Mount bush (1) and spacer (2), e.g. $s = 6.40$ mm.
- ※ Experience has shown that the required rolling torque is reached when reusing the shims being removed during disassembly (e.g. $s = 6.40$ mm). A later check of the rolling torque, however, is absolutely necessary.

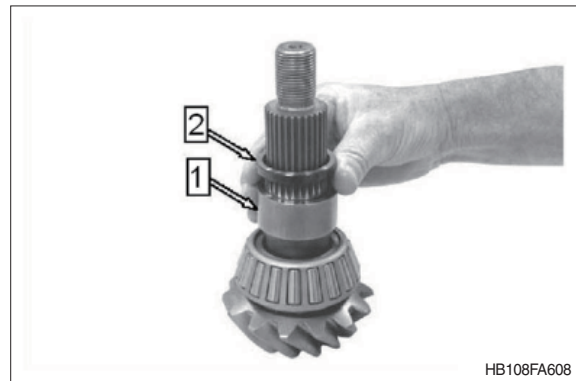

- ② Insert the preassembled input pinion into the axle housing and mount the heated roller bearing until contact is obtained.

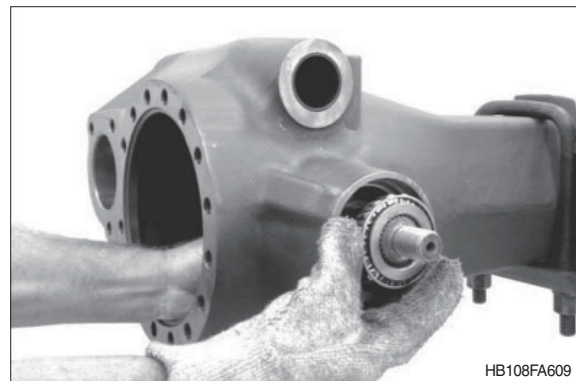

- ③ Press the screen sheet (see arrow) onto the yoke until contact is obtained.
- ※ The shaft seal ring is only mounted after acceptance of the contact pattern (see page 3-142).

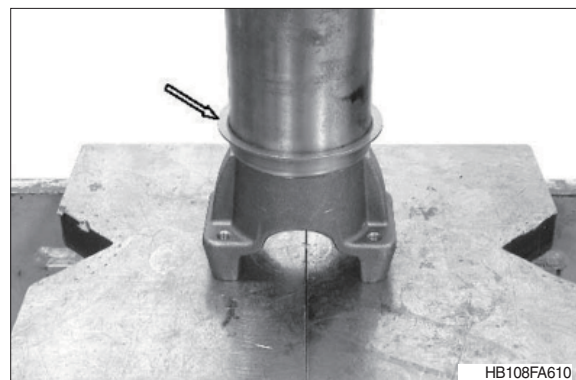

- ④ Mount the yoke and fix it with disk and hexagon nut.

· Tightening torque :
45.9 kgf · m (332 lbf · ft)

(S) Clamping fork 5870 240 025

- ※ First use the old hexagon nut (self securing), which has been removed during disassembly.

▲ While tightening, rotate the input pinion several times in both directions.

- ⑤ Check the rolling torque (0.1~0.31 kgf · m without shaft seal ring).

- ※ With new bearings try to achieve the upper value of the rolling torque.

▲ In case of deviations from the necessary rolling torque correct with a corresponding spacer ring (figure FA608, page 3-136), as specified below.

Insufficient rolling torque - mount a thinner spacer ring.

Excessive rolling torque - mount a thicker spacer ring.

(2) Setting of the backlash of crown wheel set and bearing preload of the differential

Backlash = 0.12 ∙ 0.24 mm

Bearing preload = 0.10 ∙ 0.15 mm (corresponds to a bearing rolling torque of 0.31~0.41 kgf · m [2.24~2.97 lbf · ft])

- ※ Pivot the axle housing 90°.

- ① Insert the shim e.g. $s = 0.90$ mm (recommended value) into the bearing hole and adjust the bearing outer ring until contact is obtained.

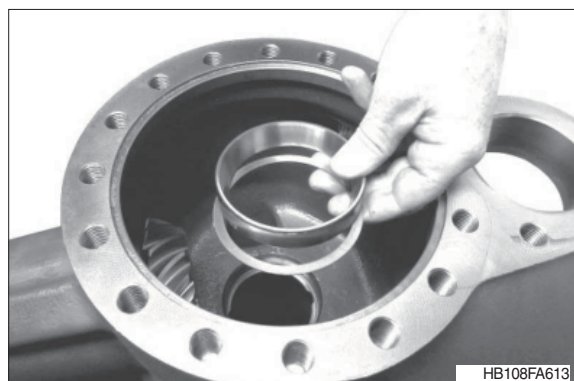
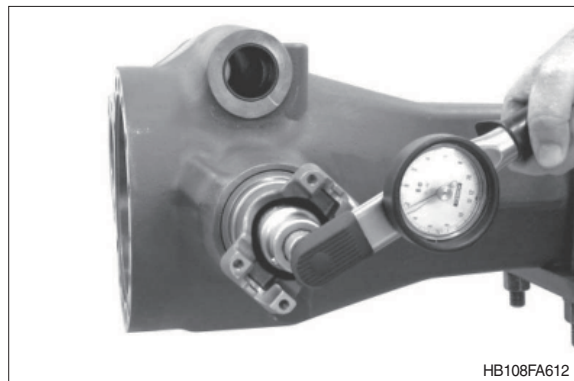
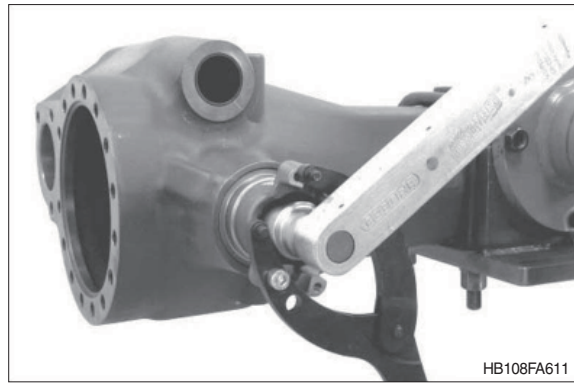

- ② Cover some drive and coast flanks with marking ink.



- ③ Insert the preassembled differential into the axle housing.

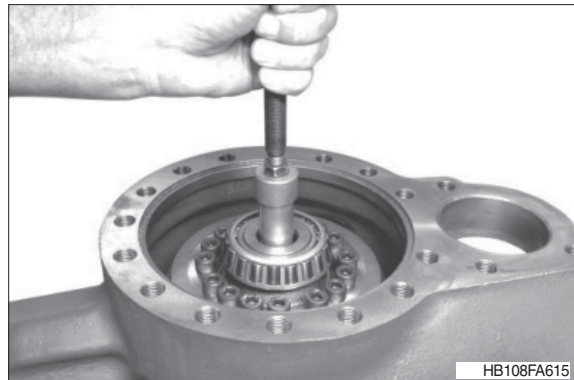

- ④ Mount the bearing outer ring.
- ※ Rotate differential and bearing outer ring in both directions, in order to assure that the rollers are positioned correctly.

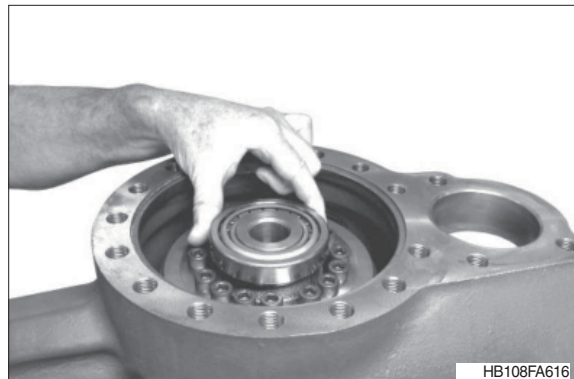

- ⑤ Align the differential centrally and determine dimension I, between the mounting face of the axle housing and the front face of the bearing outer ring.

Dimension I e.g. 9.50 mm

(S) Straightedge 5870 200 022

- ※ Take several measuring points to find the average value.

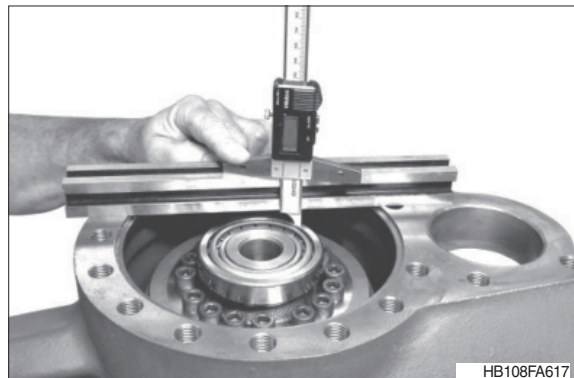

- ⑥ Determine dimension II, between the mounting face of the axle housing (part II) and the contact face of the bearing outer ring.

Dimension II e.g. 8.80 mm

Calculation example C :

Dimension I 9.50 mm

Dimension II - 8.80 mm

Difference = 0.70 mm

Required bearing preload e.g. + 0.10 mm

Leads to shim s = 0.80 mm

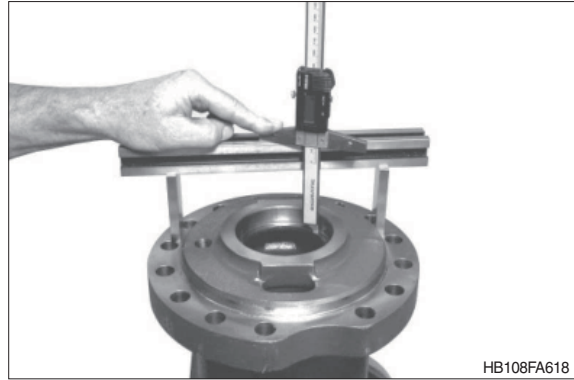

- ⑦ Insert the determined shim e.g. $s = 0.80$ into the bearing hole and adjust the bearing outer ring until contact is obtained.

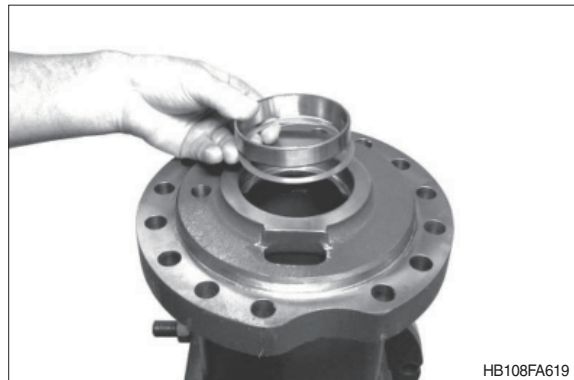

- ⑧ Mount the axle housing (part II) with the lifting device.

- ※ Provisionally mount the axle housing without O-ring.

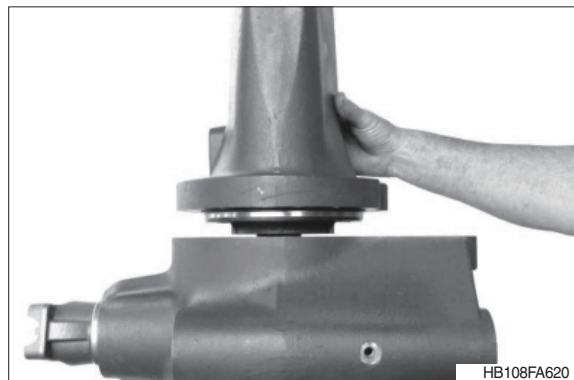

- ⑨ Check the gap between the two axle housings with a feeler gauge.

- ※ If the shim (according to calculation example C, $s = 0.80$ mm) has been determined correctly, the gap width is approx. 0.10 mm.

- ▲ Take several measuring points to find the average value.



⑩ Tighten the axle housing parts with hexagon screws until contact is obtained.

- Tightening torque (M16/10.9) :
28.6 kgf · m (207 lbf · ft)

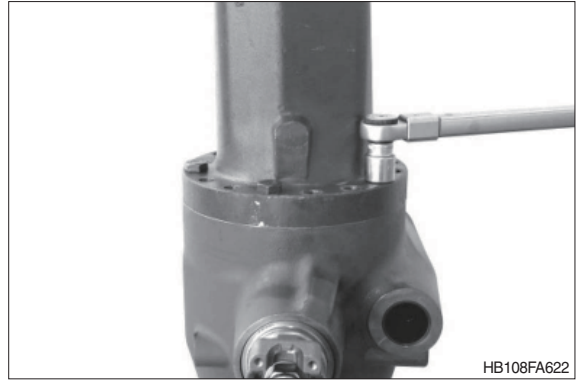

⑪ Pivot the axle housing 90° and fix the torsion bar (S) with the cone connection (S) in the hole of the cover (differential).

- (S) Torsion bar 5870 206 001
- (S) Cone connection 5870 206 003

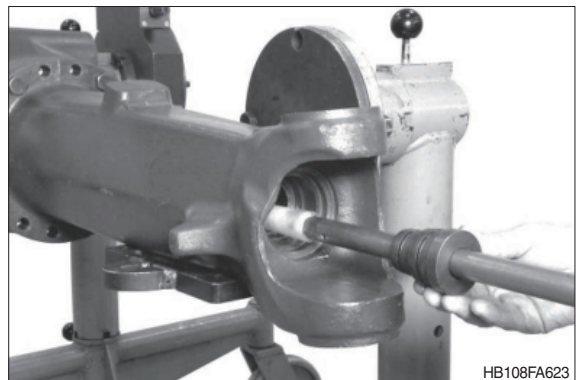

- ⑫ Place the dial indicator right-angled through the oil drain hole at a tooth flank of the crown wheel and check the backlash.

▲ **In case of deviations from the necessary backlash (0.12 ... 0.24 mm) correct with the corresponding shims.**

- **Insufficient backlash** – mount a thicker shim (figure FA613).

The shim to determine the bearing preload (figure FA619), must be accordingly thinner.

- **Excessive backlash** – mount a thinner shim (figure FA613).

The shim to determine the bearing preload (figure FA619) must be accordingly thicker.

※ **Check the contact pattern:**

Rotate the yoke to roll the crown wheel several times in both directions over the input pinion.

Then separate the axle housings and remove the differential again.

Compare the received contact pattern with contact pattern examples of page 3-213.

▲ **In case of a contact pattern deviation it is imperative to correct the measuring failures which occurred when determining the shim (figure FA606, page 3-135).**

- ⑬ Insert the differential again into the axle housing after checking the contact pattern.

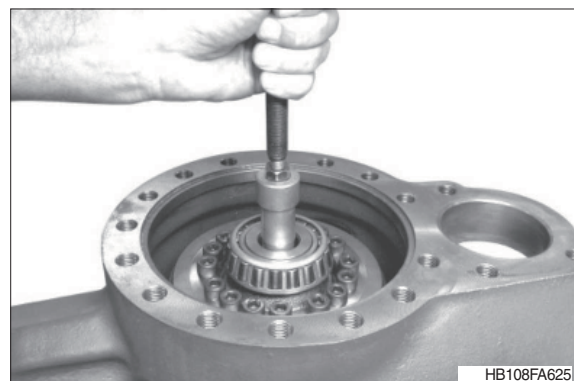
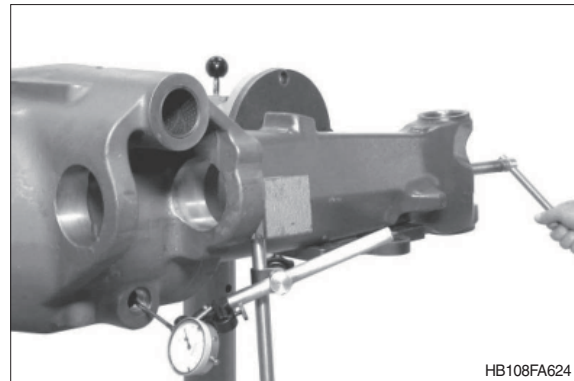

- ⑭ Grease the O-ring (see arrow) and mount it to the axle housing (part II). Then mount the axle housing (part II) until contact is obtained.

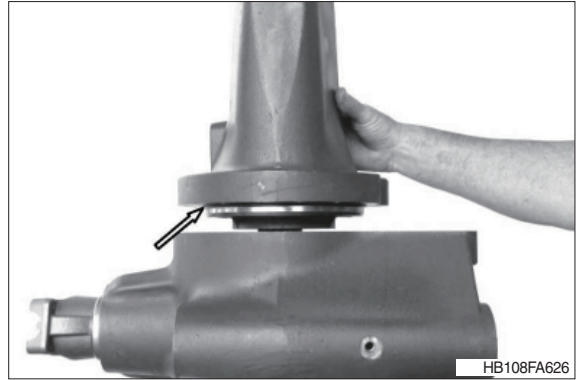

- ⑮ Finally tighten the axle housing with hexagon screws.
- Tightening torque (M16/10.9) :
28.6 kgf · m (207 lbf · ft)

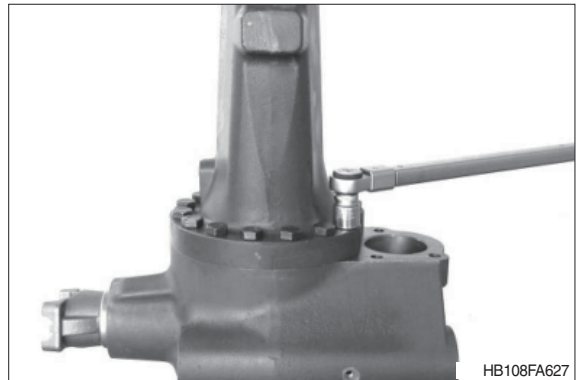

(3) Mount the shaft seal ring (yoke)

- ① Loosen the hexagon nut and pull the yoke from the input pinion.

(S) Clamping fork 5870 240 025

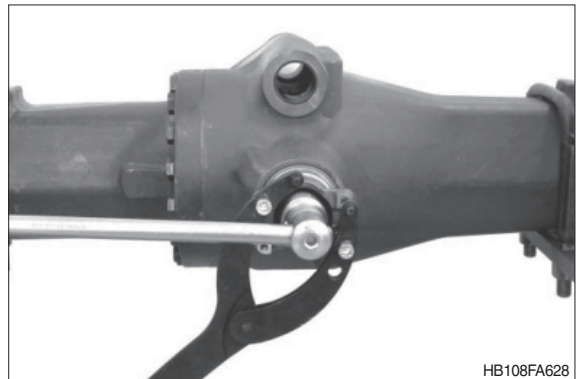

- ② Mount the shaft seal ring with the seal lip showing to the oil chamber.

(S) Driver tool 5870 048 269

- ※ Use the specified driver (S) to obtain the exact installation position of the shaft seal ring.

- ▲ Just before the assembly wet the outer diameter of the shaft seal ring with spirit and fill the space between seal and dust lip with grease.

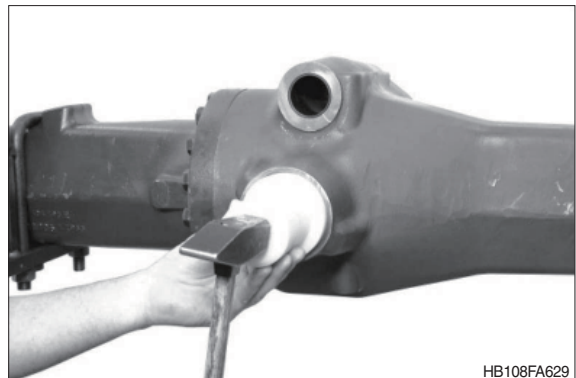

③ Mount the yoke and finally tighten with disk and **"new"** hexagon nut (self securing).

· Tightening torque :

45.9 kgf · m (332 lbf · ft)

(S) Clamping fork 5870 240 025

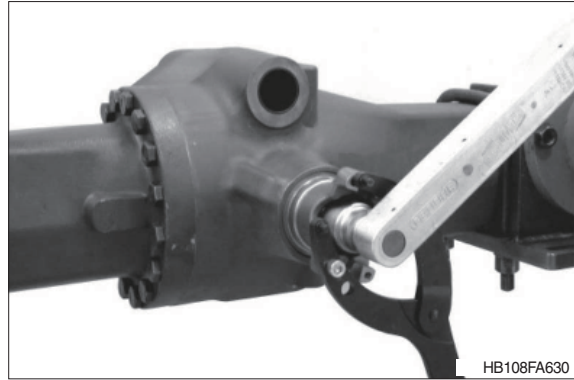

7) REASSEMBLY OUTPUT

(1) Mount the knuckle housing

- ① Flush-mount the bush into the axle housing.

(S) Driver tool 5870 055 081

(S) Handle 5870 260 002

- ▲ Pay attention to the radial installation position, the latching/cross joint of the bush must be showing upwards (12 o'clock) in installed condition.**

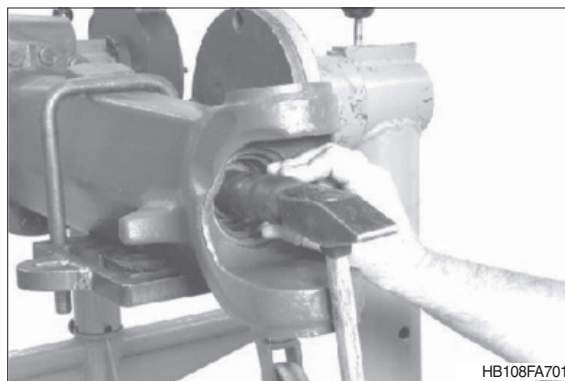

- ② Flush mount the shaft seal ring into the axle housing with the seal lip showing to the oil chamber.

(S) Driver tool 5870 048 156

(S) Driver tool 5870 048 157

- ▲ Right before the assembly wet the outer diameter of the shaft seal ring with spirit and fill the space between the seal lips with grease.**

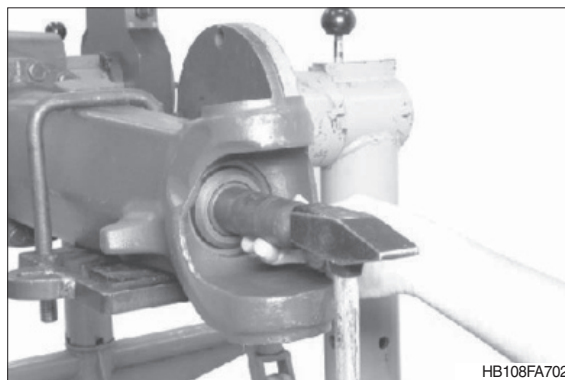

- ③ Mount both bearing outer rings until contact position with the pivot bearing holes is obtained.

(S) Driver tool 5870 058 047

(S) Driver tool 5870 058 062

(S) Handle 5870 260 002



- ④ Insert the bushes until contact position with the holes of the knuckle housing is obtained.

(S) Mandrel 5870 100 011



- ⑤ Insert the ball bearing into the knuckle housing until contact position is obtained.

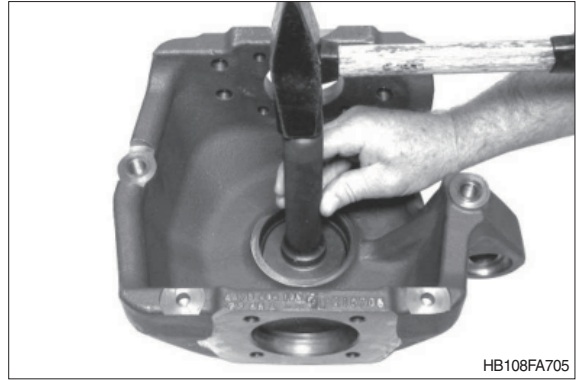

- ⑥ Fix the ball bearing with a retaining ring.

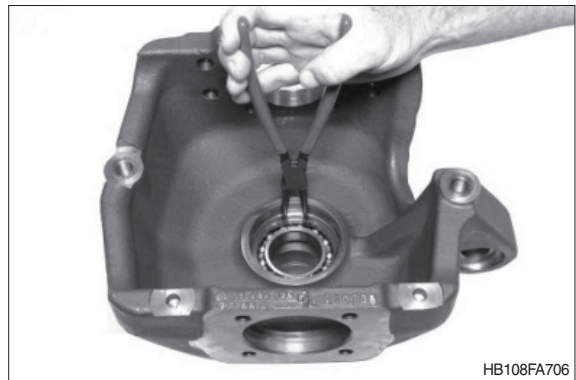

- ⑦ Insert the cassette type seal ring into the knuckle housing.

(S) Driver tool 5870 048 307

- ※ The use of the specified driver tool (S) ensures that the installation position of the cassette type ring is correct.

- ▲ Right before the assembly wet the outer diameter of the cassette type seal ring with spirit.

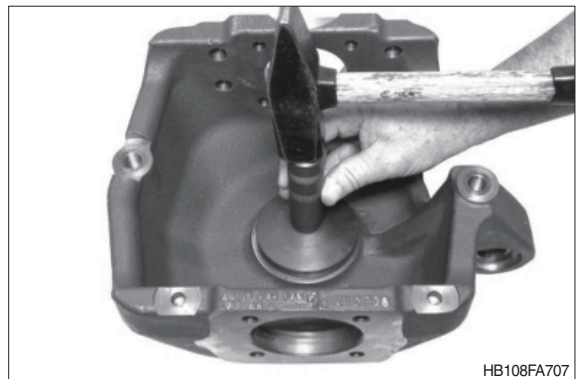

Mount the double U-joint shaft

① Insert the double U-joint shaft into the knuckle housing.

※ Right before the assembly wet the cassette type seal ring with spirit.

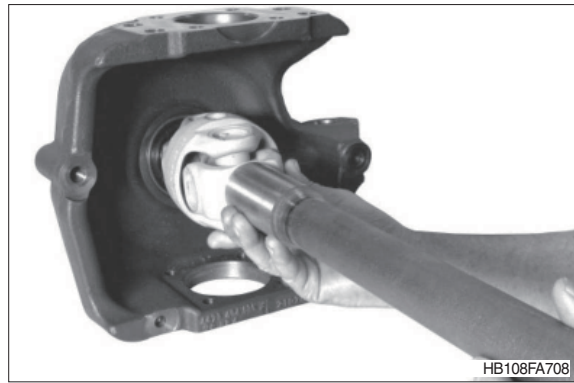

② Pull the double U-joint shaft into the knuckle housing until contact is obtained.

(S) Internal extractor 5870 300 014

(S) Counter support 5870 300 003

※ Place the internal extractor (S) into the groove of the double U-joint shaft.



③ Fix the double U-joint shaft with a retaining ring.



④ Insert the retaining ring into the groove of the double U-joint shaft.



- ⑤ Insert the sun gear shaft into the double U-joint shaft, until the retaining ring (figure FA711) engages into the annular groove (see arrow).



Mount the pivot bearing

- ① Press the shaft seal ring over the collar of the bearing bolt.

(S) Driver tool 5870 048 251

(S) Driver tool 5870 048 252

- ※ The use of the specified driver tool (S) ensures that the installation position of the shaft seal ring is correct.

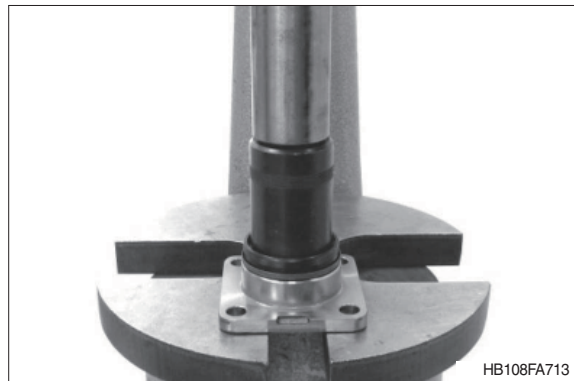

- ② Press the roller bearing onto the bearing bolts until contact position is obtained. Then wet the collar of the bearing bolts (see arrow) with anticorrosive agent (Weicon Anti-Seize).

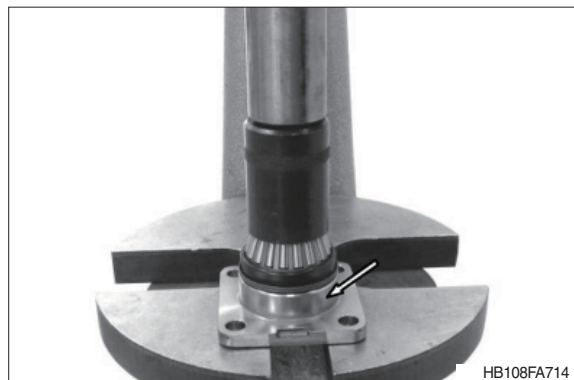

- ③ Bring the knuckle housing into correct position at the axle housing.

- ※ Thereby mount the double U-joint shaft into the axle housing until the teeth of the joint fork are mounted to the differential (axle bevel gear).

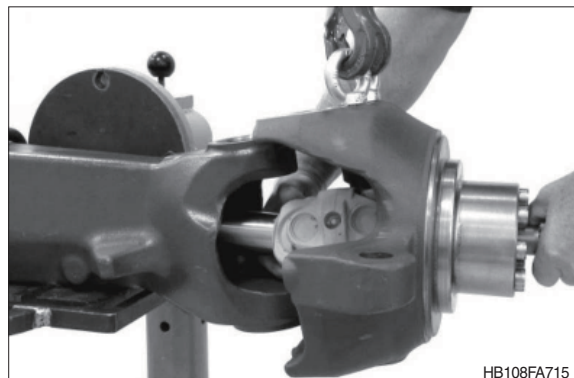

④ Fix the knuckle housing with preassembled bearing bolts (figure FA716, 717).

※ Insert the roller bearing with long-term lubricant (e.g. grease Renolit 283 EP 2). Just before the assembly wet the shaft seal ring with spirit.

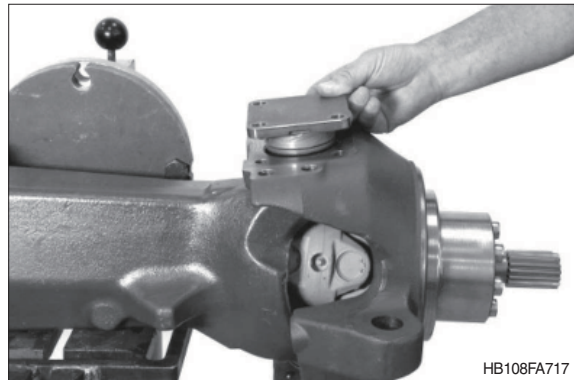
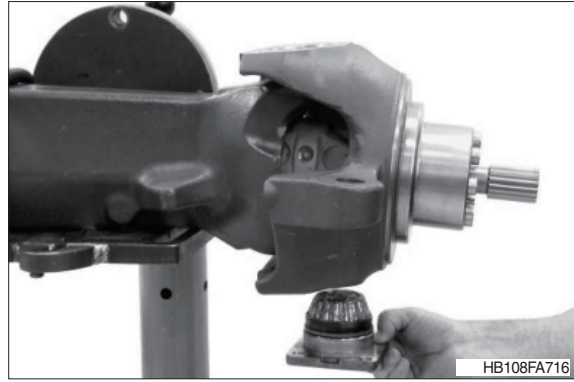

⑤ Fix both bearing bolts with hexagon screws.

· Tightening torque (M12/10.9) :
11.9 kgf · m (86.3 lbf · ft)

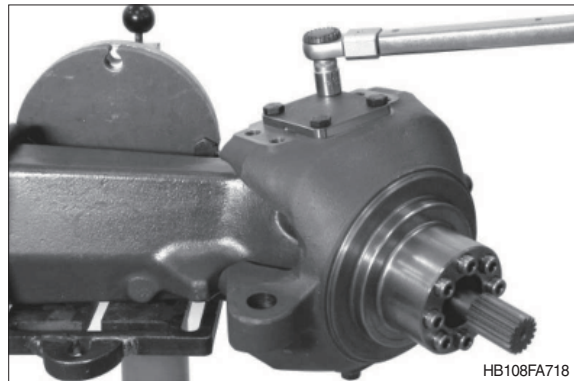

(2) Mount the hub

① Press the wheel bolts into the hub until contact position is obtained.

(S) Wheel bolt puller – basic tool
5870 610 010

(S) Insert (M22 × 1.5) 5870 610 002

※ The special tool (S) is only intended for repair solutions when replacing single wheel bolts with mounted hub.

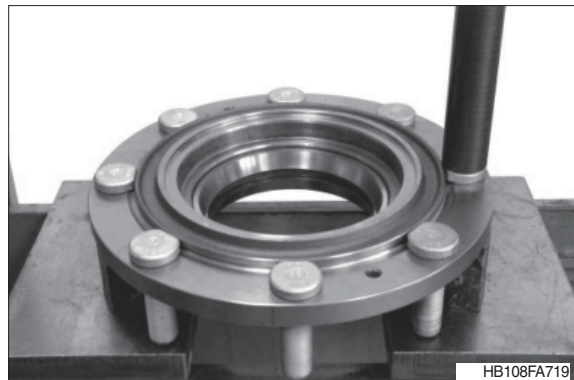

- ② Press both bearing outer rings in until contact position is obtained.

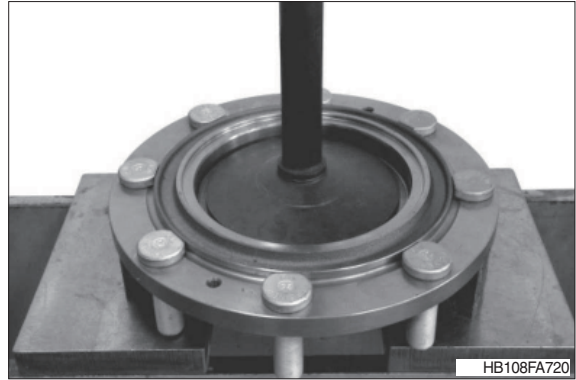

- ③ Press the cassette type seal with the label OUT SIDE showing outwards (upwards) into flush position with the hub.

(S) Driver tool 5870 051 035

- ※ The use of the specified driver tool (S) ensures that the installation position of the cassette type seal ring is correct.

- ▲ Just before the assembly wet the outer diameter of the cassette type seal ring with spirit.

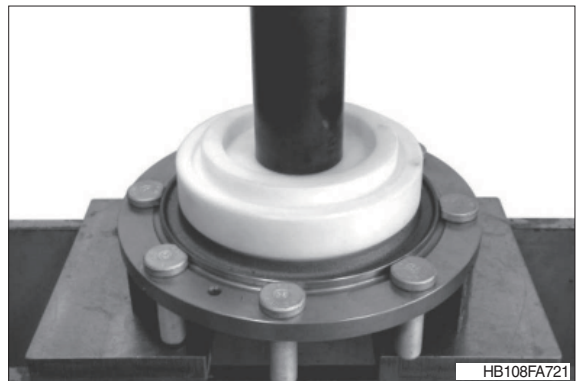

- ④ Heat the roller bearing and mount until contact position with the knuckle housing is obtained.

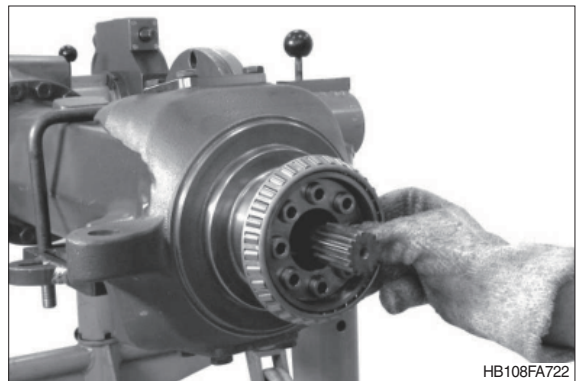

- ⑤ Mount the preassembled hub.

- ※ Right before the assembly wet the seal lips of the shaft seal ring with spirit.

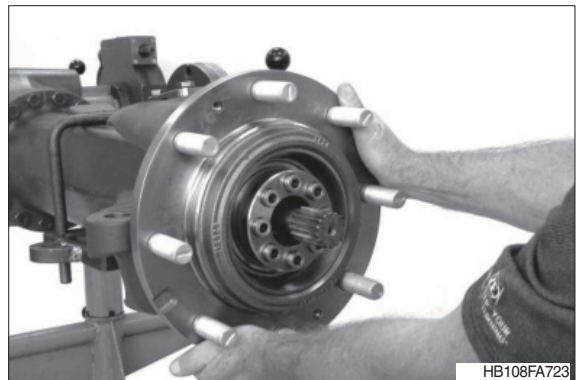

- ⑥ Heat the roller bearing and mount until contact position is obtained.

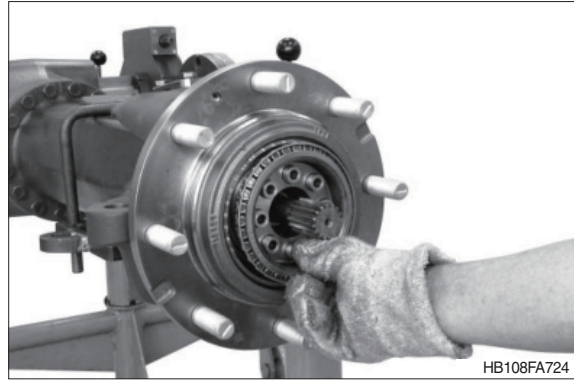

- ⑦ Mount the ring gear and pre-tighten with the old retaining screws (which have been removed during disassembly) until contact position is obtained. Then loosen the retaining screws again and finally tighten the ring gear with **new** retaining screws.

- Tightening torque :
9.18 kgf · m (66.4 lbf · ft)

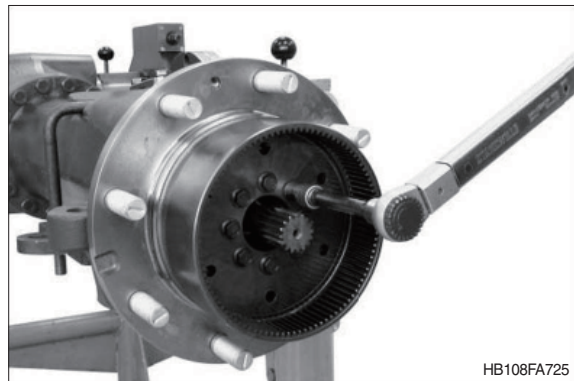

- ⑧ Insert the O-ring (see arrow) into the annular groove of the hub and grease.

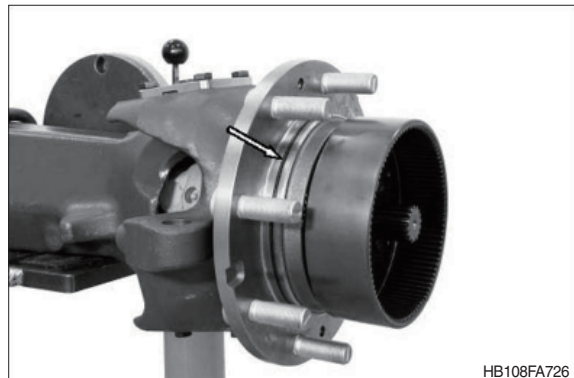

(3) Mount the planetary carrier

- ① Insert the cylindrical roller bearing into the planetary gear – for this purpose press the cylindrical roller bearing through the packaging sleeve until the snap ring engages into the annular groove of the planetary gear.

※ The packaging sleeve is used as assembly aid.

- 1 = Cylindrical roller bearing
- 2 = Packaging sleeve
- 3 = Snap ring
- 4 = Planetary gear

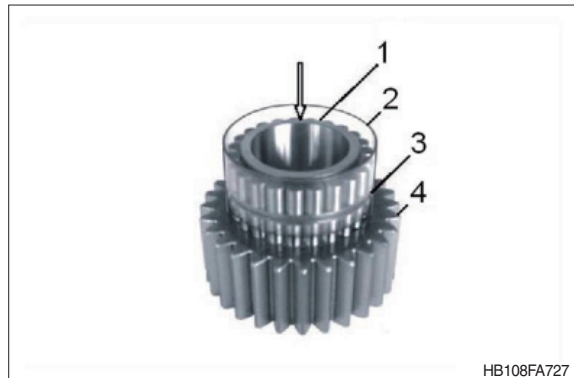

② Heat the bearing inner ring and mount the planetary gear until contact position is obtained.

※ Mount the bearing inner ring with the large radius showing to the planetary carrier (downwards).

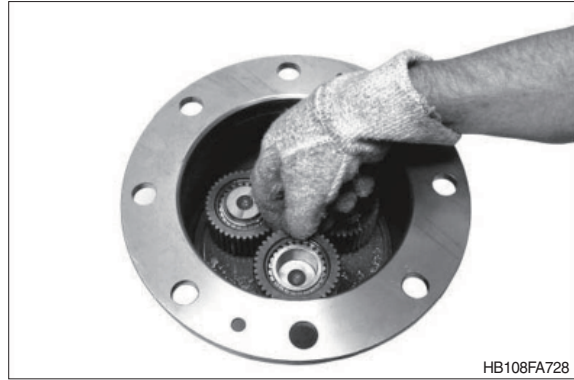

③ Fix the planetary gear with a retaining ring.

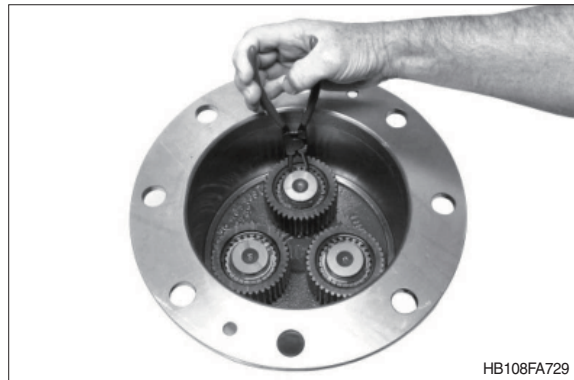

④ Mount the planetary carrier and fix it with cylindrical screws.

· Tightening torque (M10/8.8) :
3.26 kgf · m (23.6 lbf · ft)

※ Prior to putting the axle into operation, fill it with specified oil.



8) REASSEMBLY STEERING

(1) Preassemble the steering

- ① Pre-assemble the cylindrical tube as shown on the sketch.

1 = Cylindrical tube
2 = Rod seal
3 = Scraper

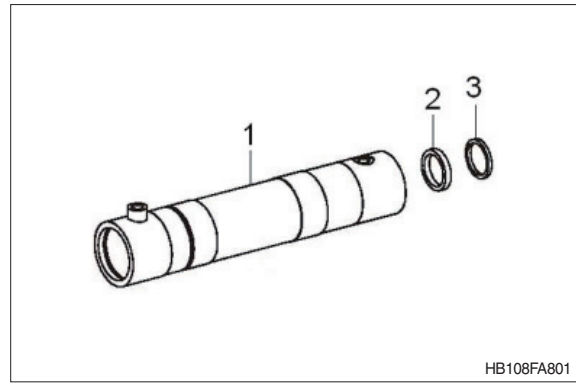

- ② Pre-assemble the piston rod as shown on the sketch.

1 = Piston rod
2 = Guide ring
3 = Piston seal
4 = Spacer part

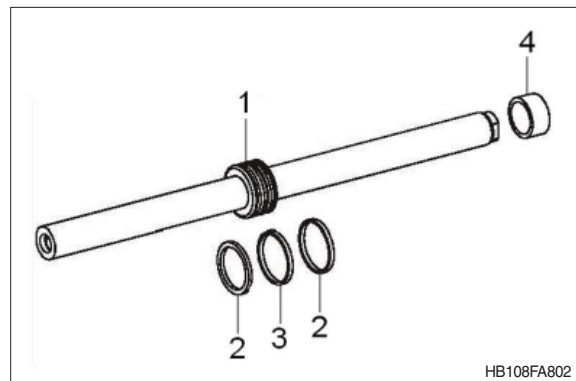

- ③ Pre-assemble the plug as shown on the sketch.

1 = Plug
2 = Dual ring
3 = Rod seal
4 = Scraper



- ④ Push the preassembled piston rod into the cylindrical tube until contact position is obtained.

※ Slightly oil all seal elements before inserting the piston rod.



- ⑤ Push the preassembled plug into the cylindrical tube, until the retaining ring (see sketch below) can be mounted.

※ Slightly oil all seal elements before inserting the plugs.



- ⑥ Engage the retaining ring into the groove of the cylindrical roller.

※ Installation position, see also sketch ⑧.



- ⑦ Use the piston rod to bring the plug in contact position with the retaining ring.



- ⑧ Fill the space (X) between plug and cylindrical tube with grease.

Comment on sketch:

1 = Retaining ring

2 = Plug

3 = Piston rod

4 = Cylindrical tube

X = Space grease filling

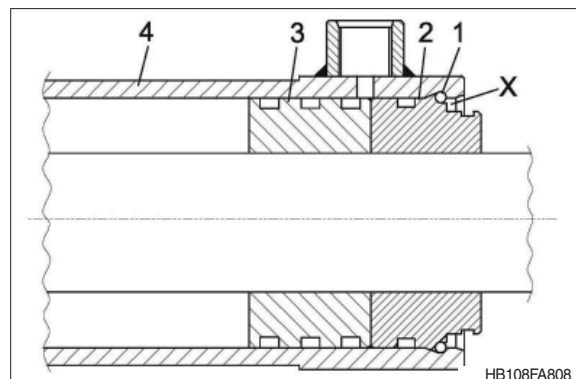

- ⑨ Use a retaining ring to fix the plug.

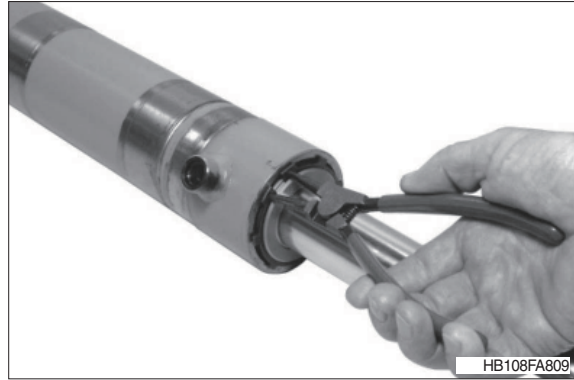

- ⑩ Mount the flange and fix with a ring.

(S) Pliers

5870 900 026

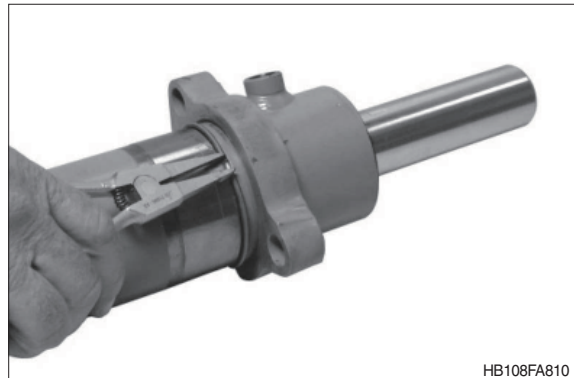

(2) Mount the steering

- ① Wet the contact faces (cylindrical tube/ axle housing, see arrows) with anti-corrosion agent (Weicon Anti-Seize).

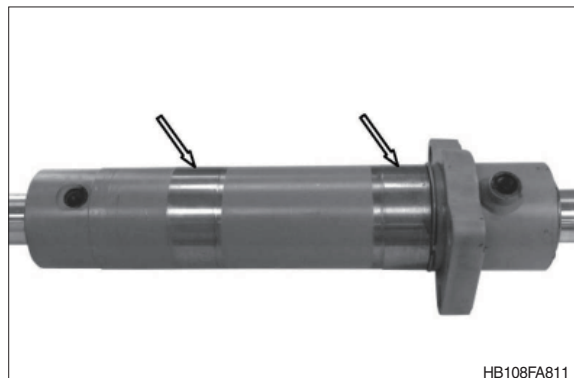

- ② Mount the pre-assembled steering cylinder into the holes of the axle housing.

Then fix the steering cylinder with hexagon screws.

· Tightening torque :

24.5 kgf · m (177 lbf · ft)

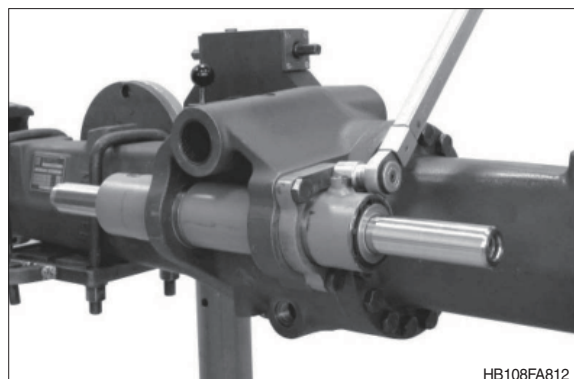

③ Screw hexagon nut and ball joint to the axial joint.

※ Operation (figure FA813~815) must be implemented on both tie rods.



④ Fix the preassembled tie rod to the piston rod.

· Tightening torque :
30.6 kgf · m (221 lbf · ft)

※ Wet the thread of the axial joint with loctite #243.



⑤ Mount the tie rod to the joint housing and fix with **new** hexagon nut (self-securing).

· Output torque : 10.2 kgf · m (73.8 lbf · ft)
· Tightening rotation angle ... = $180^{\circ} +45^{\circ}$

※ First tighten the hexagon nut with a tightening torque of 10.2 kgf·m (73.8 lbf·ft) $\pm 15\%$.

Then mark the position of the hexagon nut and retighten with a rotation angle of $180^{\circ} +45^{\circ}$.

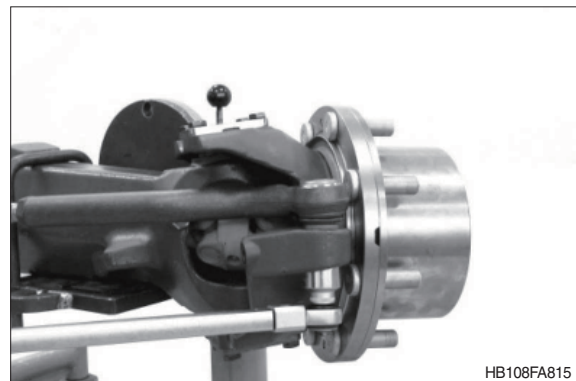

⑥ Flush mount the bushes on both sides into the axle housing.

(S) Driver tool 5870 058 018
(S) Handle 5870 260 002

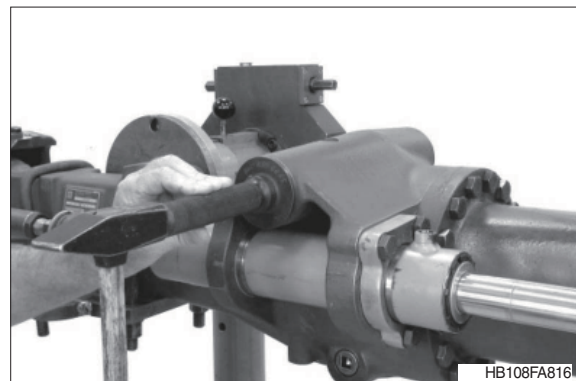

(3) Adjustment and check of track

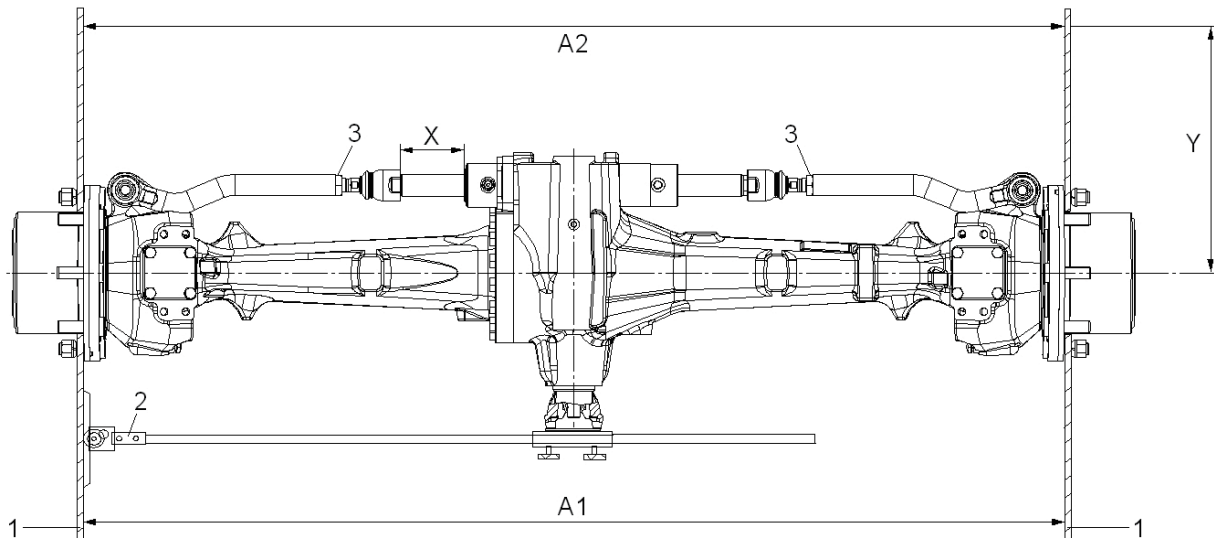

HB108FA817

Basic track setting

Bring the piston rod into central position.

Setting of dimension $X = 121.75$ mm (measured between front face/steering cylinder and front face/axial joint).

- ※ The axial position of the piston rod may no more be changed during track setting.
Mount the straightedges (1) in horizontal and central axis position.
Fix the measuring device (2) to the yoke.
Loosen the hexagon nut (3) and set the length of the tie rod (axial joint), until 0° (= track setting of zero mm) can be read on the measuring device (2).
- ※ For a toe-in and toe-out setting, which might be required, stick to the vehicle manufacturer's specification.
- ※ Carry out setting on both output sides.

Comment on sketch:

1 = (S) Straightedges 5870 200 029

2 = (S) Measuring device 5870 200 033

3 = Hexagon nut

X = Setting dimension 121.75 mm

Check track setting (0°) :

Determine dimension A1.

Turn both outputs by 180° – Dimension A2 must be identical with dimension A1.

Dimension Y = distance between wheel center and rim flange.

Then fix both tie rods (axial joint) with hexagon nut (3).

- Tightening torque : $30.6 \text{ kgf} \cdot \text{m}$ ($221 \text{ lbf} \cdot \text{ft}$)

(4) Setting of steering angle

- ※ If track setting should be carried out, the setting of the steering angle should only be carried out after completion of the track setting.

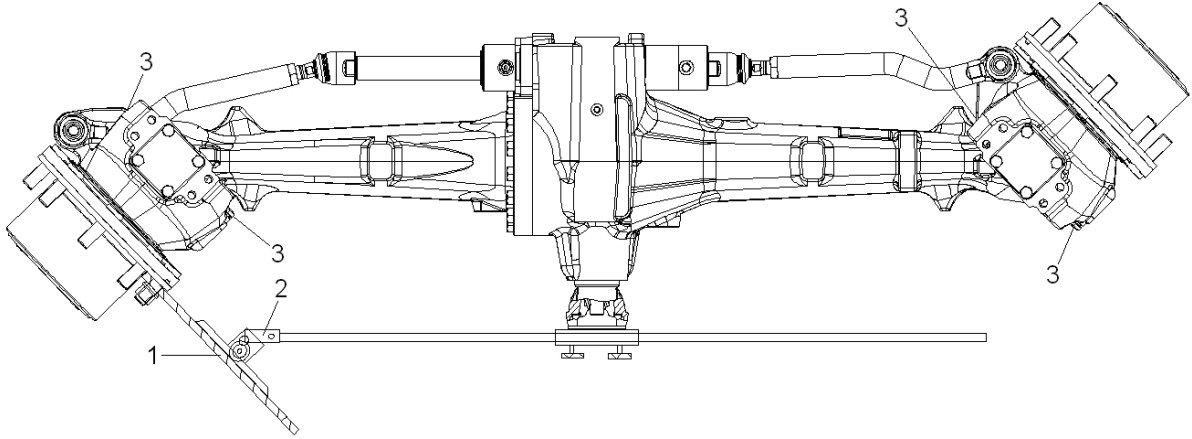

HB108FA818

Mount the straightedge (1) in horizontal and central axis position.

Fix the measuring device (2) to the yoke.

Pivot the output until the steering angle (e.g. 52°) can be read on the measuring device (2).

Then bring the stop screws (3) into contact position with the axle housing and lock them with hexagon nuts.

· Tightening torque (M14×1.5) : 15.3 kgf · m (111 lbf · ft)

- ※ The value of the required steering value can be taken from the vehicle manufacturer's specifications.
- ※ Carry out the setting on both output sides.

Comment on sketch:

1 = (S) Straightedge	5870 200 029
2 = (S) Measuring device	5870 200 033
3 = Stop screws	

(5) Leakage test of the steering

Use a HP pump to check the steering for leakage in **both** steering directions.

Build up test pressure $p = 200$ bar (thereby bleed the pressure chamber).

Then close the connection to the HP pump with a shut-off valve.

During a 20 second testing time a pressure decrease of max. 5 bar is permitted.

- ※ Test medium : Engine oils SAE 10W

(S) HP pump	5870 287 007
(S) Threaded coupling	5870 950 115

4. REAR AXLE

1) DISASSEMBLY - OUTPUT UNIT

Parking brake (multi-disc brake)

- 1 = Input
- 2 = Axle drive housing
- 3 = Bearing housing
- 4 = Axle housing
- 5 = Output unit
- 6 = Parking brake

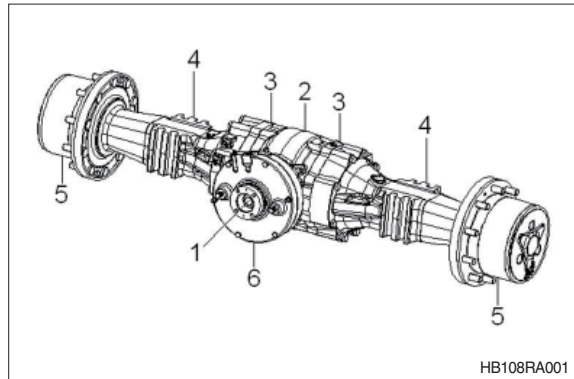

(1) Mount axle on assembly truck.

Assembly truck	5870 350 000
Fixtures	5870 350 139
Fixing bracket	5870 350 140

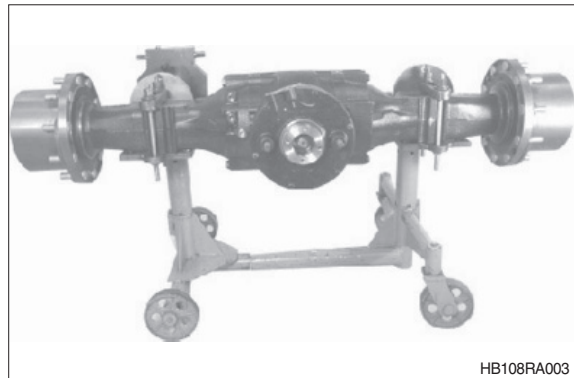

(2) Remove screw plug (arrow) and drain oil from the axle.

- ※ Use suitable collector-environmental protection.

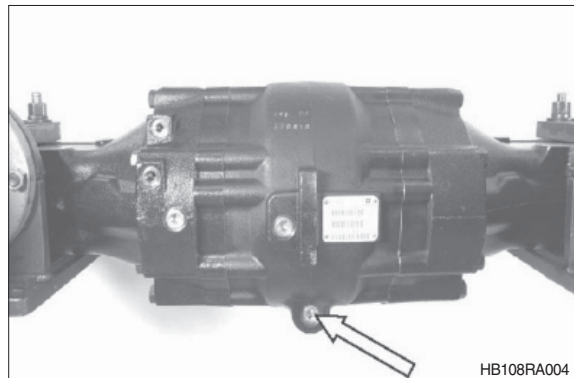

(3) To rotate the output (oil drain hole in 6 o'clock position – see figure RA006) equalize the brake fixing on the axle which was removed from the vehicle by turning in the two emergency breathing screws (arrows).

- ※ Turn in both emergency breathing screws evenly.

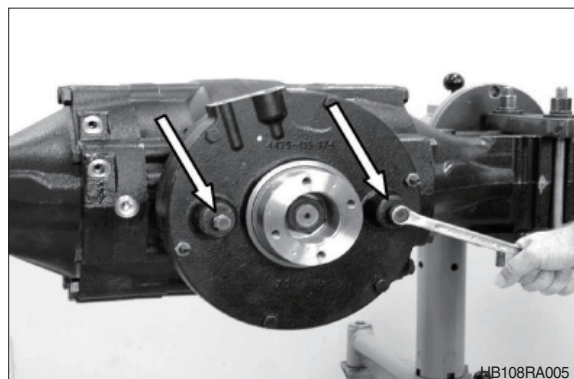

(4) Remove screw plug (arrow) and drain oil from both output units.

※ Use suitable collector – environmental protection.

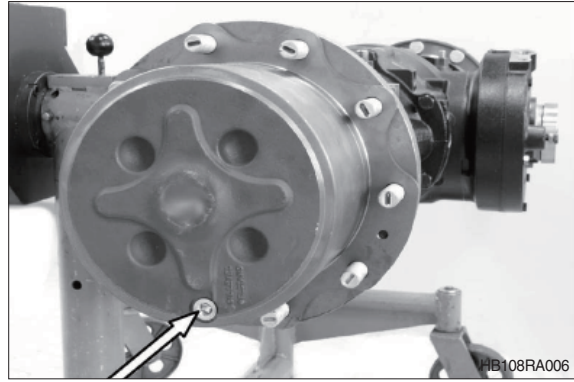

(5) Loosen both hex screws (arrows) of planetary carrier fixing.

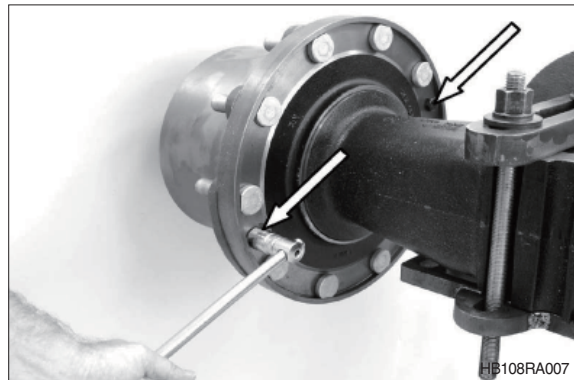

(6) Take up planetary carrier by means of a lifting strap and pull it off the hub.

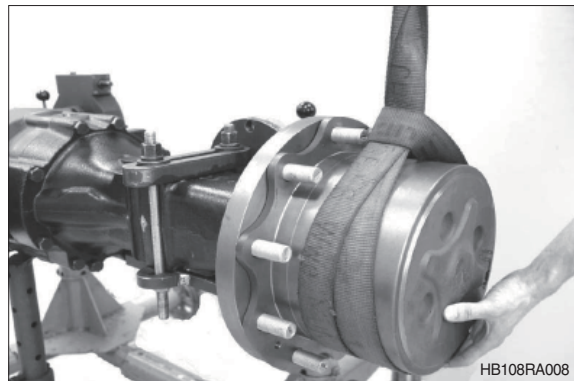

(7) Snap out retaining ring.



- (8) Pull off planetary gear.
Disassemble the remaining planetary gears in the same way.

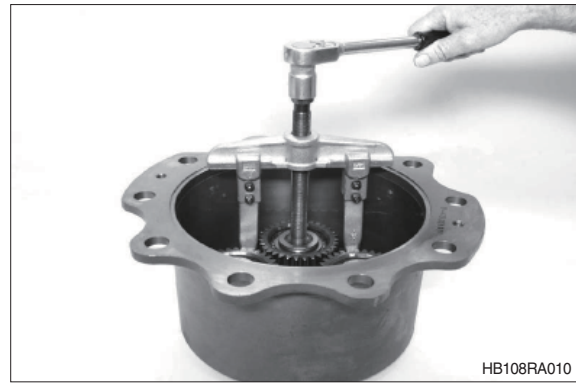

- (9) Pull out sun gear shaft and remove O-ring (arrow).

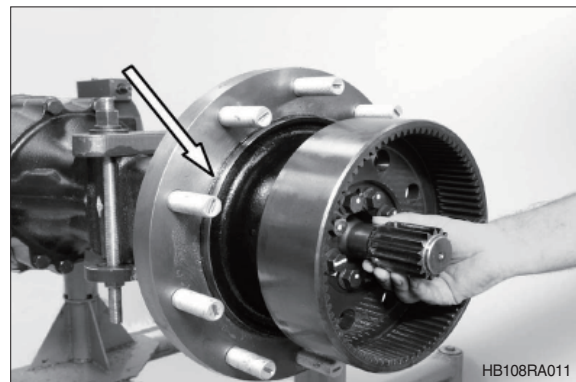

- (10) Loosen locking screws of internal gear bolting.

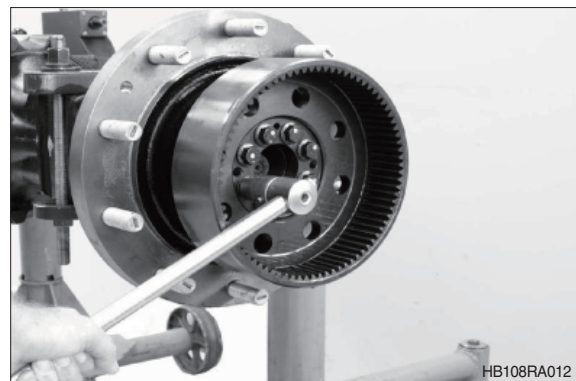

- (11) Insert two adjusting screws (M14 – see arrows) and press internal gear evenly off the axle housing by means of puller screws.

Adjusting screws (M14) 5870 204 022

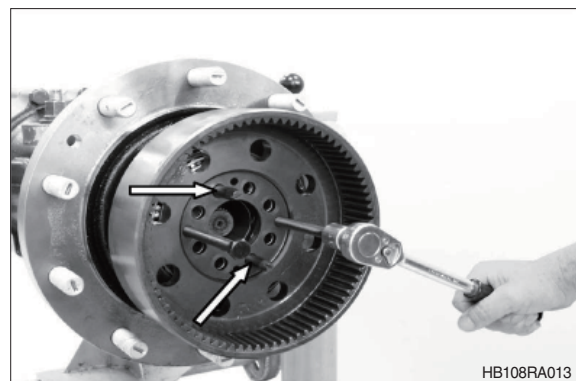

- (12) If required – remove bushings from internal gear.
 For this purpose fit bushings with thread and pull them out by means of a striker.



- ※ To ensure functioning replace shaft seal (cassette-type sealing) after any disassembly of hub - see figure RA016.
- (13) Pull hub off the axle housing using a pressure piece and a two-armed puller.
- ※ Pay attention that releasing bearing inner ring does not drop.

Lifting bracket 5870 281 043

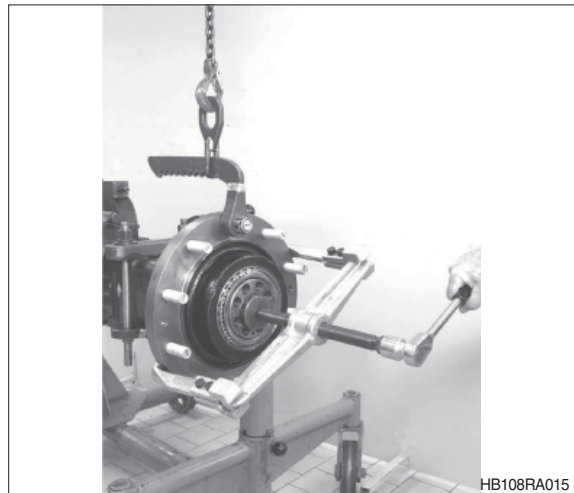

- (14) Lift off shaft seal (arrow) with lever and remove both bearing outer rings from hub.

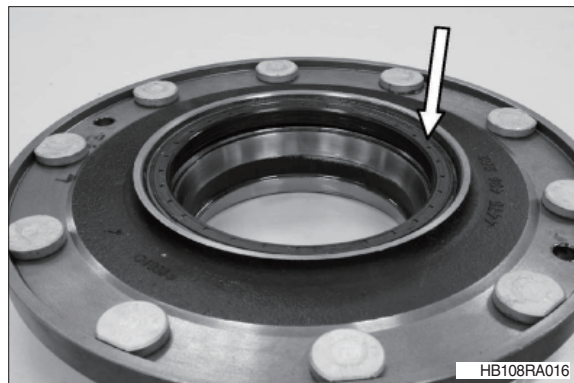

- (15) Pull bearing inner ring off the axle housing.

Grab sleeve 5873 004 026

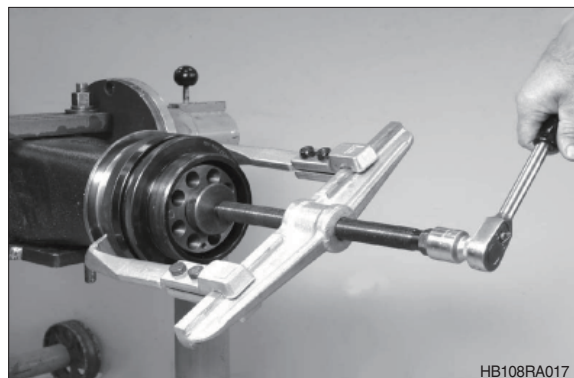

2) DISASSEMBLY

SERVICE BRAKE (multi disc brake)

(1) Legend :

- 1 = Service brake (multi disc brake)
- 1a = Crown wheel side
- 1b = Side opposite of crown wheel
- 2 = Differential
- 3 = Differential lock (100% lock)
- 4 = Axle drive housing
- 5 = Bearing housing (crown wheel side)
- 6 = Axle housing (crown wheel side)
- 7 = Bearing housing (side opposite of crown wheel)
- 8 = Axle housing (side opposite of crown wheel)

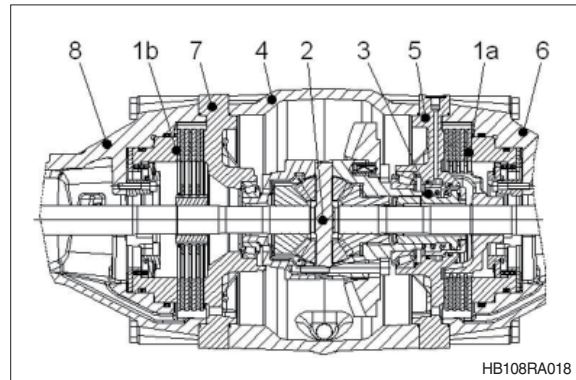

- ※ The description below shows the disassembly of the service brake on the axle housing (crown wheel side). The service brake on the other axle housing (side opposite of crown wheel) must be disassembled in the same way to a large extent.

▲ **Secure axle by means of a support, see arrow.**

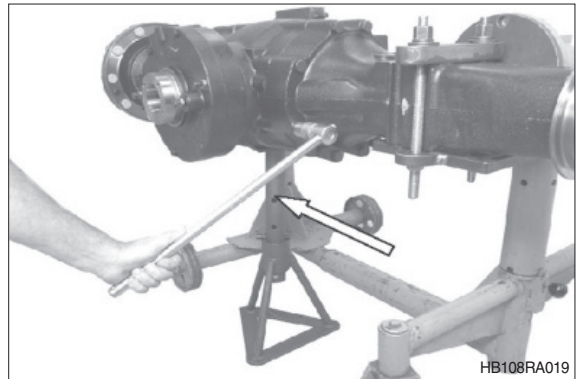

- (2) Loosen screws (axle housing/bearing housing/axle drive housing-crown wheel side).

- (3) Take up axle housing by means of a lifting strap, insert two adjusting screws (M16) – see arrows – and separate axle housing from bearing housing.

- ※ Pay attention that releasing O-rings do not drop.

Adjusting screws	5870 204 053
Assembly lever	5870 345 065

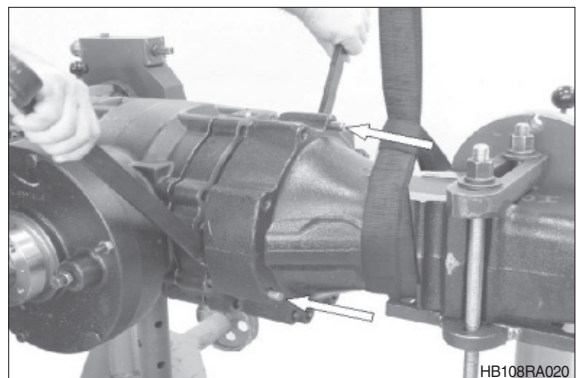

- (4) Remove cpl. stub shaft (with inner disc carrier) from axle housing.

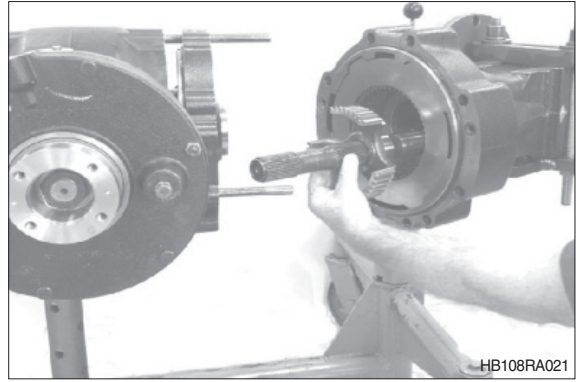

- (5) Unsnap retaining ring and pull inner disc carrier from the stub shaft.



- (6) Take disc package out of axle housing.

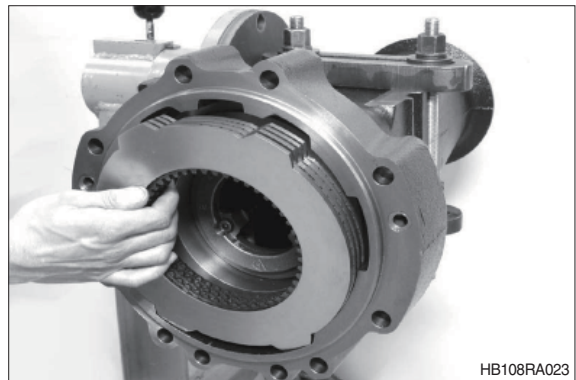

- (7) Remove O-rings (arrows 1+2).

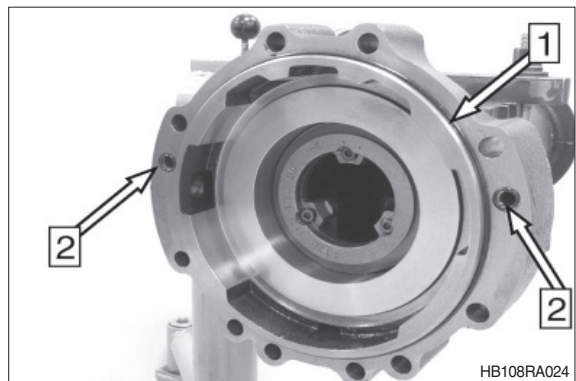

(8) Loosen screws and remove cpl. ring.

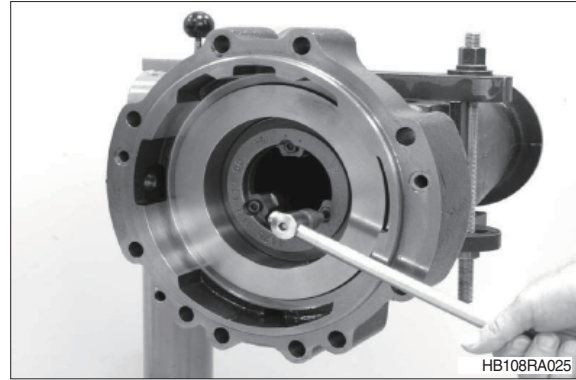

(9) Equalize cup spring preload by a press, unsnap retaining ring and remove washer.

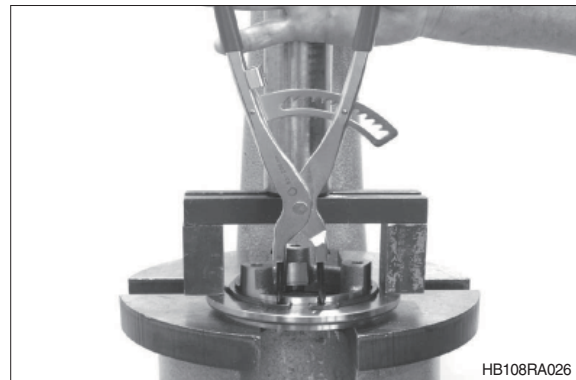

(10) Press off piston by means of compressed air, remove washer and cup spring behind.

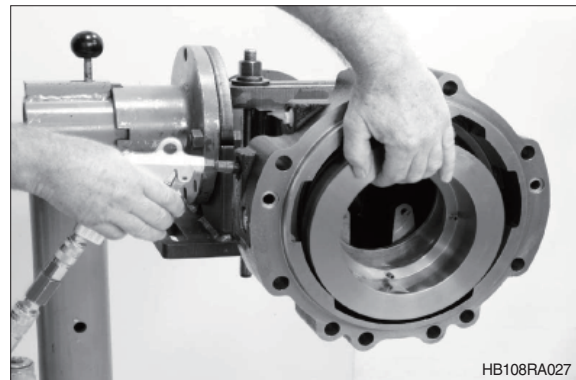

(11) Remove sealing elements from axle housing and piston-see arrows.

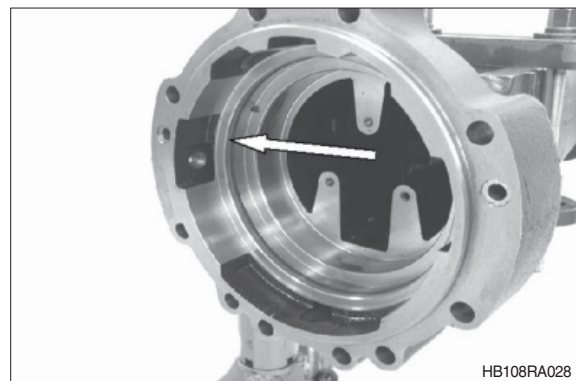
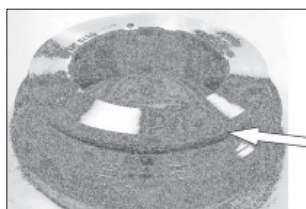

3) DISASSEMBLY-DIFFERENTIAL WITH 100% LOCK

- (1) If it is necessary to dismantle the differential and/or the input pinion, separate the axle housing assy (crown wheel side-see item 6) from bearing housing/axle drive housing.

Legend to sketch no. 1:

- 1 = Differential
- 2 = Differential lock (100% lock)
- 3 = Axle drive housing
- 4 = Bearing housing (crown wheel side)
- 5 = Bearing housing (side opposite of crown wheel)
- 6 = Axle housing (crown wheel side)
- 7 = Axle housing (side opposite of crown wheel)

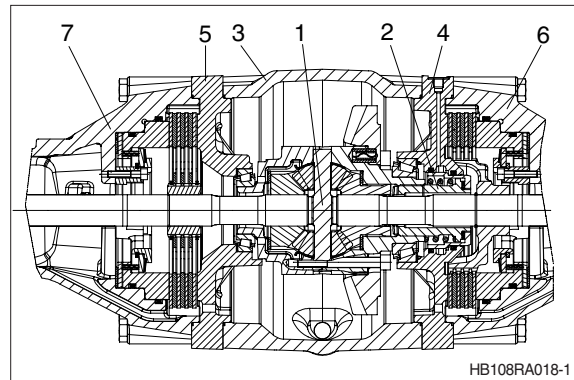

- ▲ **Secure axle by means of a support, see arrow.**

- (2) Loosen screws (axle housing/bearing housing/axle drive housing-crown wheel side).

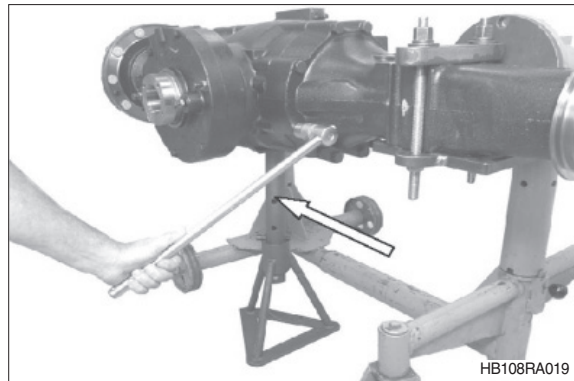

- (3) Take up axle housing by means of lifting strap, insert two adjusting screws (M16) – see arrows – and separate axle housing from bearing housing.

- ※ Pay attention that releasing O-rings do not drop.

Adjusting screws 5870 204 053
Assembly lever 5870 345 065

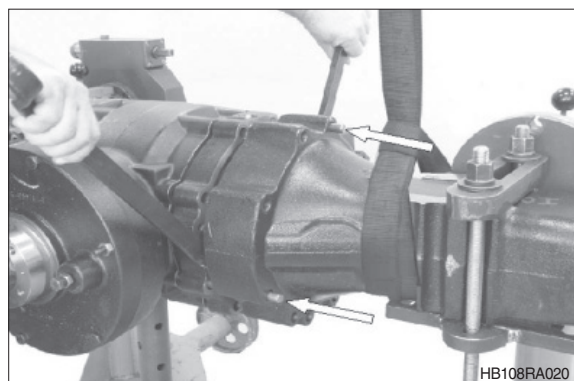

(4) Remove bearing housing.

※ Pay attention that releasing O-rings do not drop.

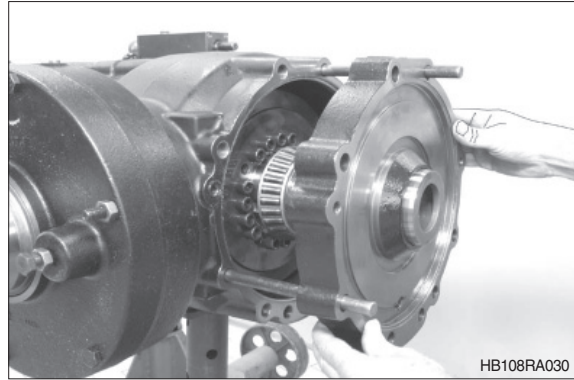

(5) Press off piston by means of compressed air and remove O-ring (arrow).

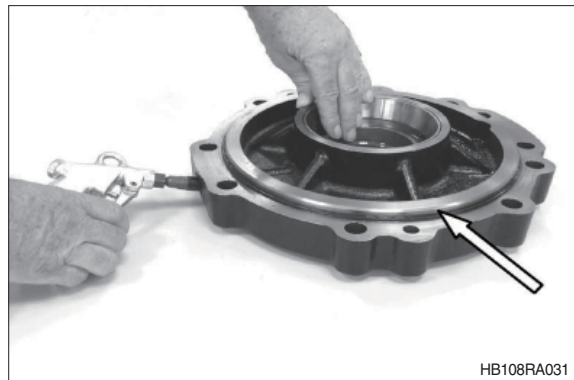

(6) Remove bearing outer ring and shim (differential bearing preload).



(7) Remove sealing elements (arrows) from bearing housing.

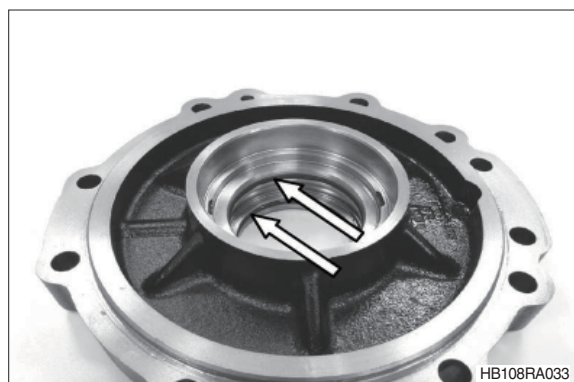

- (8) Take cpl. locking slide out of differential.
Remove O-rings (arrows).

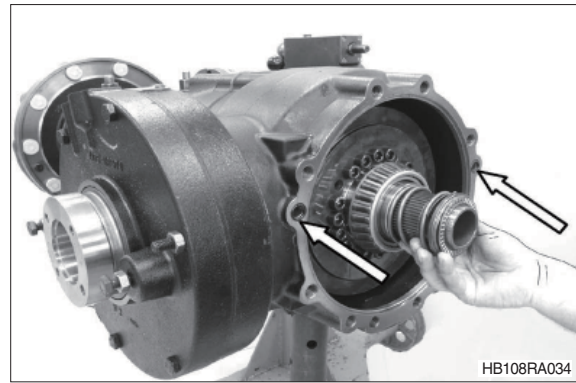

- (9) Single parts of locking slide
1 = Locking slide
2 = Compression spring
3 = Axial needle cage

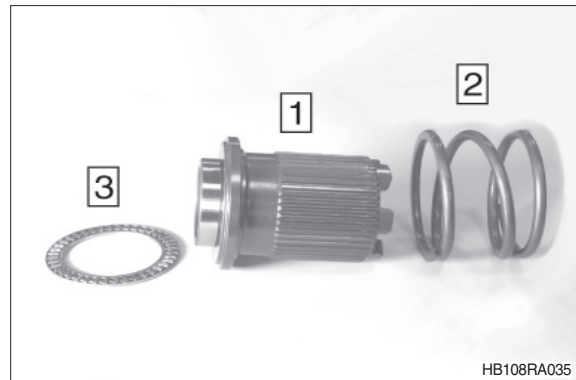

- (10) Remove both hexagon screws (arrows) of planetary carrier fixing (output on side opposite of crown wheel).

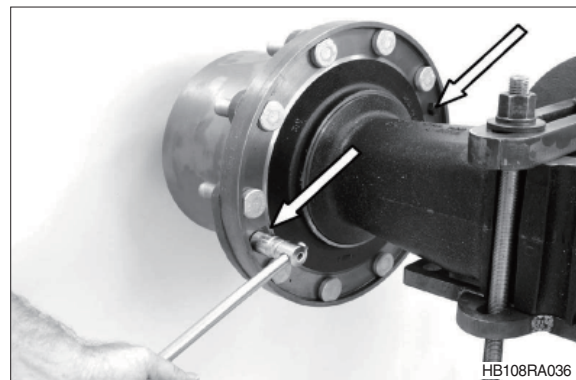

- (11) Take up planetary carrier by means of lifting strap and pull it off the hub.

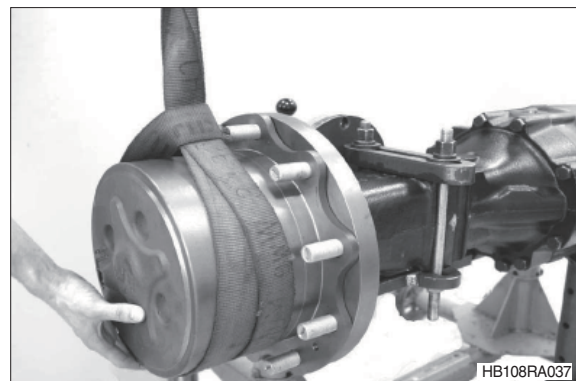

(12) Pull off sun gear shaft and stub shaft.

※ Pay attention that releasing differential does not drop.

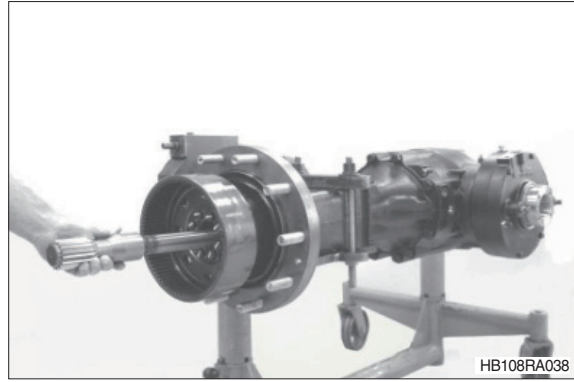

(13) Bring axle in upright position and lift differential out of the axle.

Internal extractor 5870 300 019
Eye nut 5870 204 073



(14) Pull off bearing inner ring.

Grab sleeve 5873 002 027
Basic tool 5873 002 001



(15) Pull off bearing inner ring.

Grab sleeve

5873 001 059

Basic tool

5873 001 001



HB108RA041

(16) Loosen screws.



HB108RA042

(17) Separate differential carrier halves and remove single parts.



HB108RA043

(18) Separate crown wheel from differential carrier.

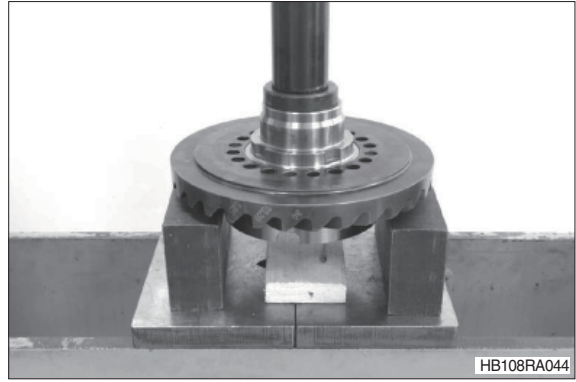

(19) Remove bearing outer ring and the shim behind (backlash).

※ Mark shim (position/bearing allocation).

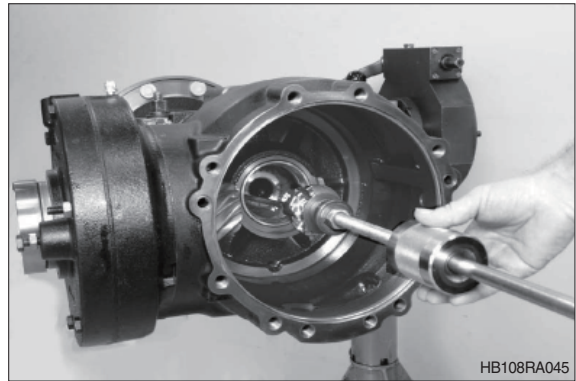

4) DISASSEMBLY - INPUT

※ The below description shows the disassembly of the input on the axle with parking brake (multi-disc brake).

▲ **Secure axle by means of a support-see arrow.**

- (1) Fix input flange using a clamping fork, loosen hexagon nut and pull off input flange.

Difficult disassembly. Hexagon nut has been located with locking compound (loctite), if required, heat up hexagon nut with hot air blower.

Clamping fork 5870 240 025

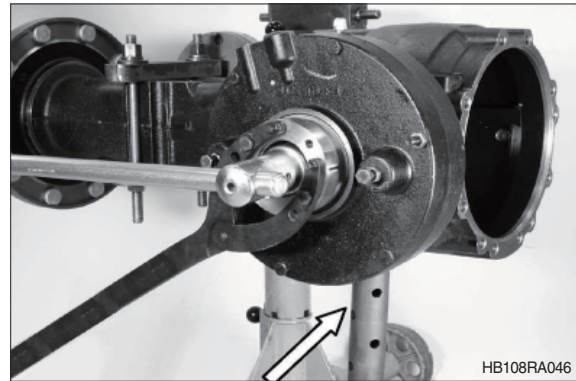

- (2) If required – lift off shaft seal with lever.

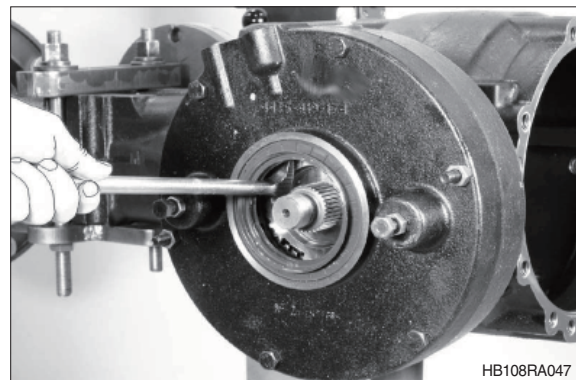

- (3) Work steps figure RA048~051.

Remove hexagon screws of brake housing bolted connection and loosen the two hexagon nuts evenly (brake housing is subject to compression spring preload).

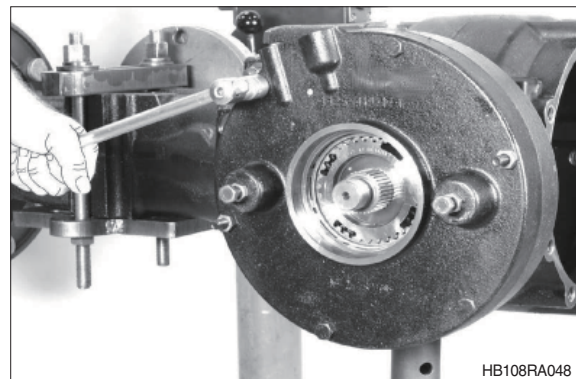

(4) Take off the cpl. brake housing cover.

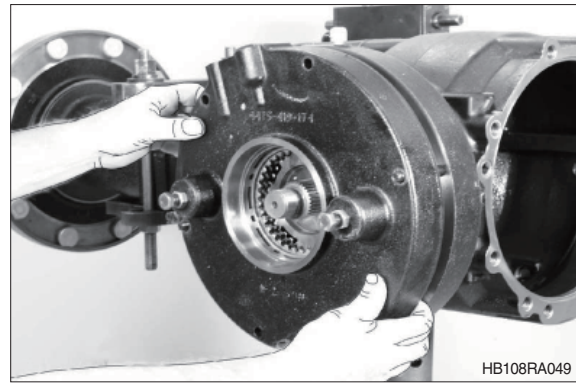

(5) Remove disc carrier.

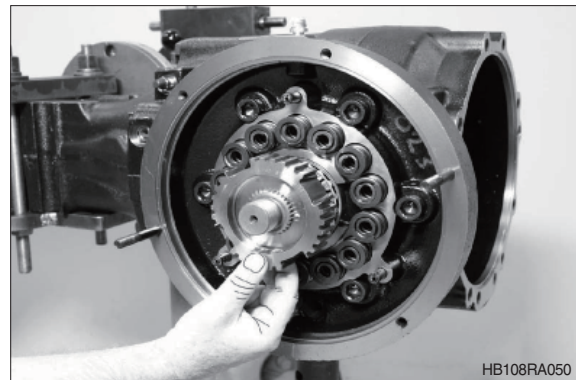

(6) Remove compression springs.

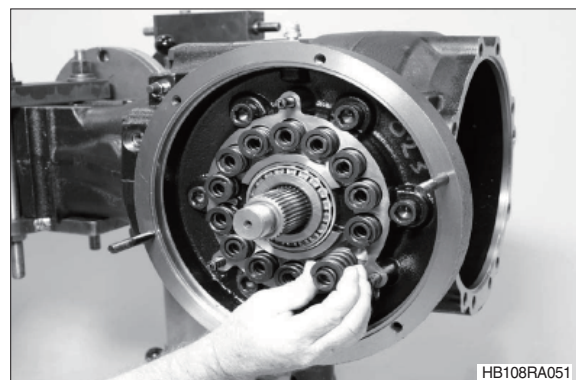

(7) Press off input pinion by means of two-armed puller – pay attention that releasing bearing inner ring does not drop.

※ The input pinion can also be dismantled on the disassembled brake housing.

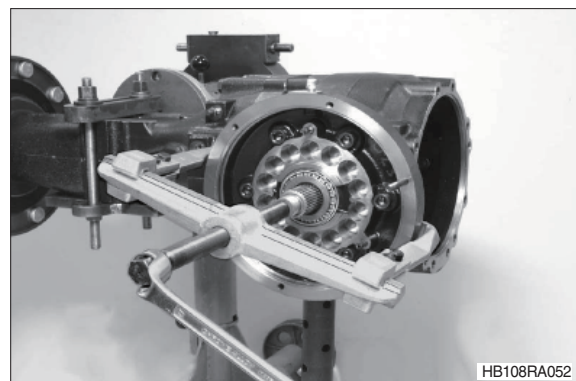

(8) Remove spacer ring (arrow) from input pinion and pull off bearing inner ring.

Grab sleeve 5873 001 037

Basic tool 5873 001 000



(9) Drive internal bearing outer ring off the housing hole - pay attention that releasing shim (contact pattern/ bevel gear set) does not drop.

※ Mark shim (strength/position and bearing allocation).

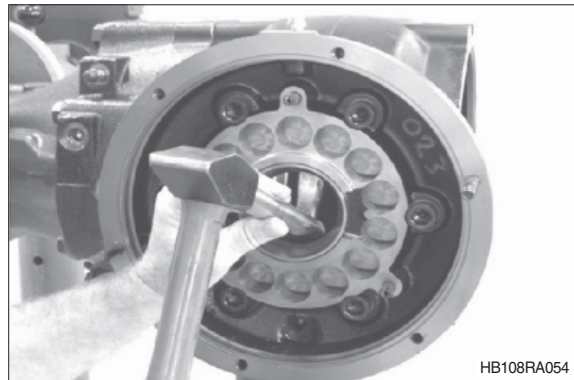

(10) Pull out external bearing outer ring.

Internal extractor 5870 300 019

Counter support 5870 300 020

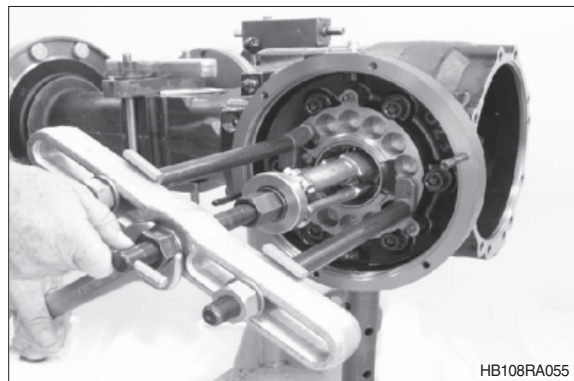

(11) Loosen cylinder screws, turn in two adjusting screws (M16)-see arrows-and separate brake housing by means of slight hits with a plastic hammer.

Adjusting screws (M16) 5870 204 023

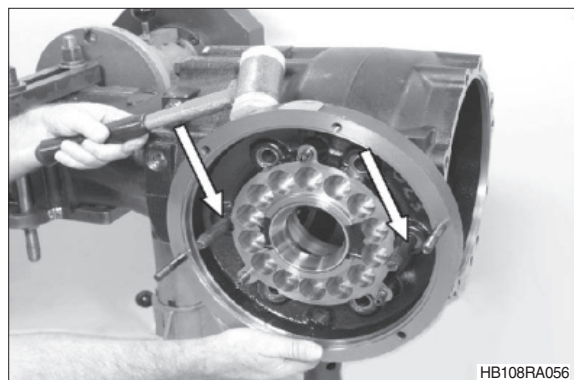

5) DISASSEMBLY

PARKING BRAKE (multi disc brake)

※ Disassembly of parking brake (multi-disc brake) was shown as part of the whole disassembly of the axle- disassembly, however, can also be made on the fully mounted axle.

▲ **Secure axle by means of a support - see arrow.**

(1) Fix input flange using a clamping fork, loosen hexagon nut and pull off input flange.

※ Difficult disassembly. Hexagon nut has been located with locking compound (loctite), if required, heat up hexagon nut with hot air blower.

Clamping fork 5870 240 025

(2) If required – lift off shaft seal with lever.

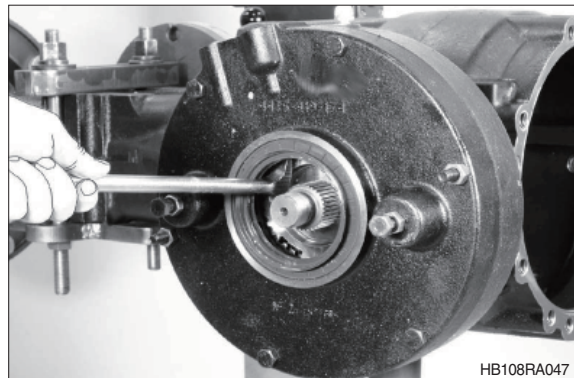
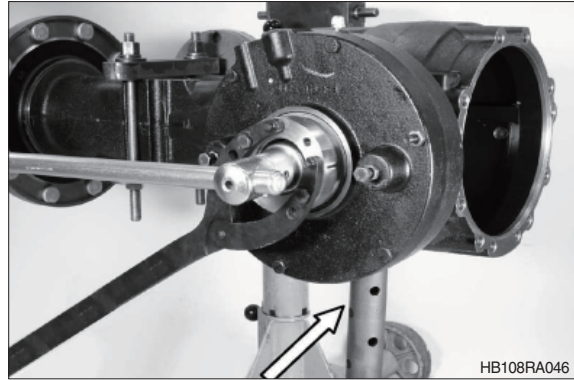

(3) Remove hexagon screws of brake housing bolted connection and loosen the two hexagon nuts evenly (brake housing is subject to compression spring preload).

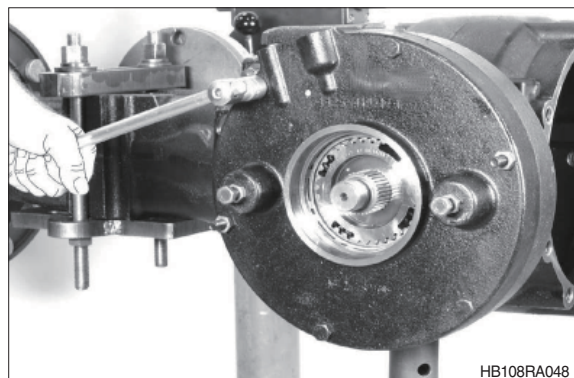

(4) Take off the cpl. brake housing cover.

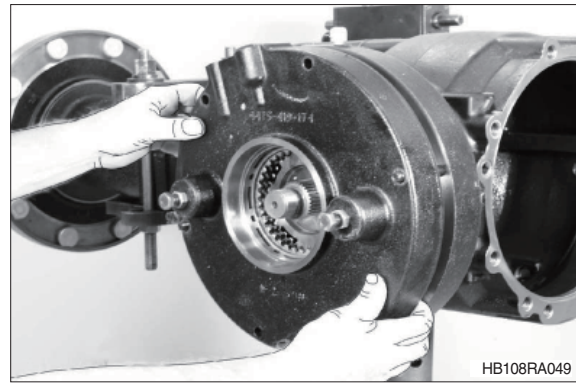

(5) Remove disc carrier.

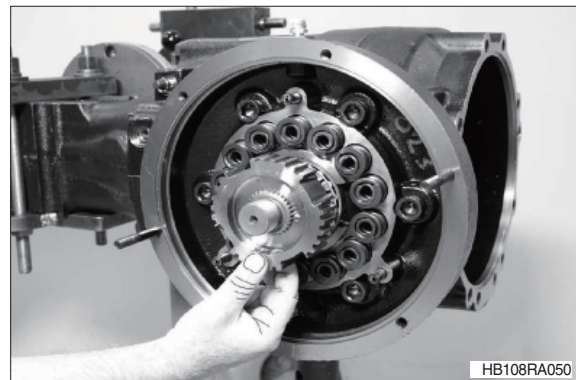

(6) Remove compression springs.

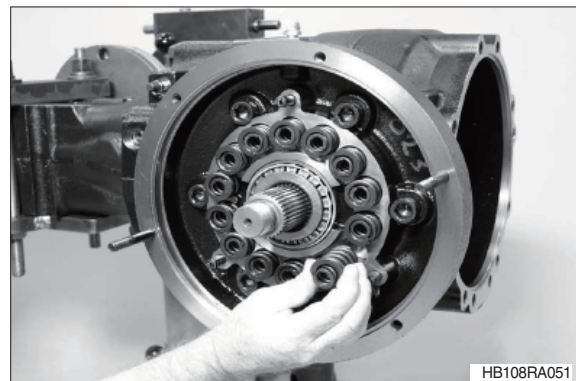

(7) Press piston out of brake housing cover by means of compressed air.

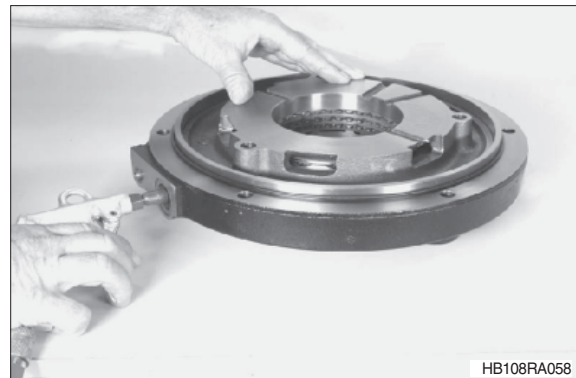

- (8) Take disc package out of brake housing cover.



- (9) Remove sealing elements-see arrows- from the grooves of the brake housing cover.



- (10) Pull off both bolts (with O-ring).
Remove O-ring (arrow).



- (11) If required, disassemble brake housing (figure RA062+063) : For this purpose, the cpl. differential must be dismounted first-in this connection see parts of section **3) Disassembly differential of page 3-165.**

Press-off input pinion using a two-armed puller-pay attention that releasing bearing inner ring does not drop.

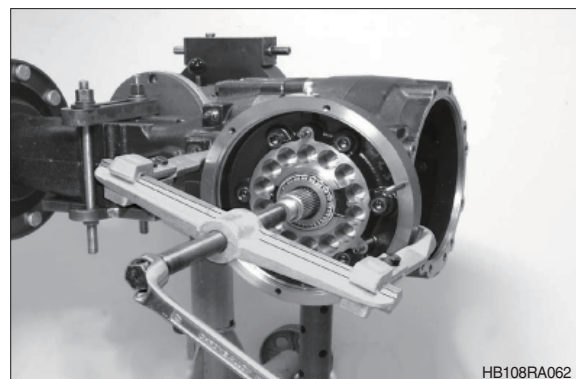

(12) Loosen cylinder screws, turn in two adjusting screws (M16)-see arrows-and separate brake housing by means of slight hits with a plastic hammer.

Adjusting screws (M16) 5870 204 023

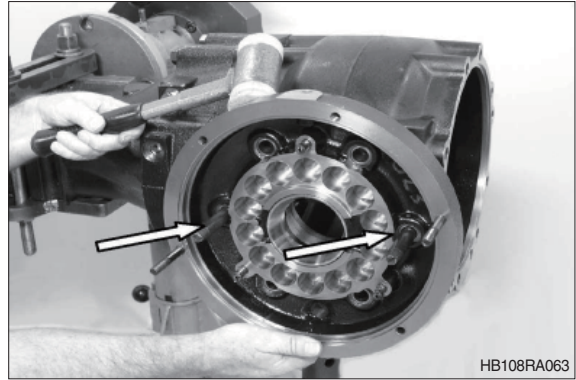

6) REASSEMBLY - INPUT

- ※ The adjacent figure shows the INPUT in the axle with parking brake (multi-disc brake).

Legend :

- 1 = Input pinion
- 2 = Crown wheel
- 3 = Inner roller bearing
- 4 = Shim (contact pattern)
- 5 = Adjust ring (rolling torque)
- 6 = Outer roll bearing
- 7 = Disc carrier
- 8 = Shaft seal
- 9 = Washer
- 10 = Hexagon nut
- 11 = Flange
- 12 = Axle drive housing
- 13 = Brake housing
- 14 = Brake housing cover

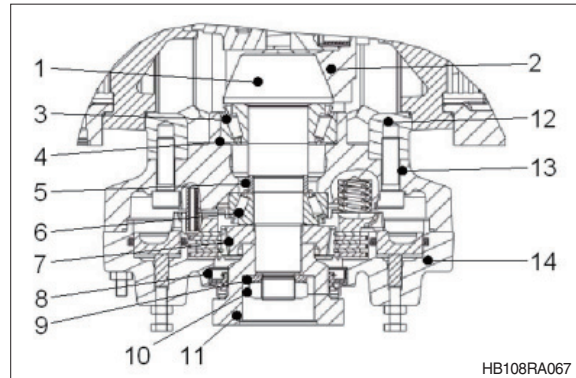

(1) Determine shim for pinion position required to obtain an optimum contact pattern on the bevel gear set (crown wheel/pinion) :

- ① Insert shim (e.g. $S = 1.60 \text{ mm}$) into hole of brake housing.
- ※ We would recommend to reinstall the shim found during disassembly (e.g. $S = 1.60 \text{ mm}$ – refer to disassembly instructions, page 3-173, figure RA056) into the inner bearing hole /pinion bearing.
- ※ As an alternative, e.g. when assembling new parts (pinion or roller bearing) – a basic setting of the required pinion position can be made as described below (figure RA075~078).

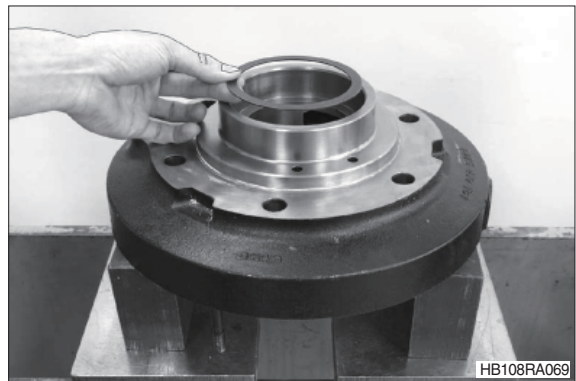

※ The contact pattern required on the bevel gear set, however, is decisive. Any deviation – see contact pattern check on page 3-190 figure RA106, demands a correction of the pinion position by a corresponding shim.

② Insert bearing outer ring until contact is obtained.

Driver 5870 058 078
Grip 5870 260 002

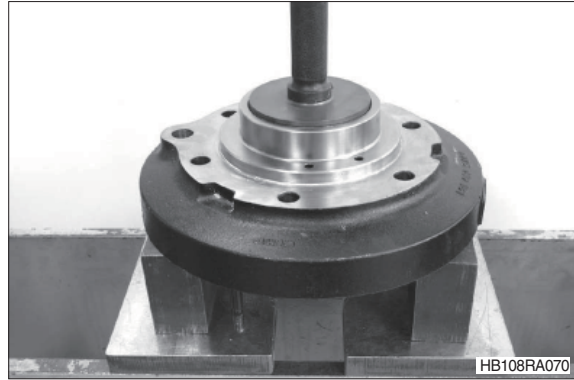

③ Insert bearing outer ring until contact is obtained.

Driver 5870 058 078
Grip 5870 260 002

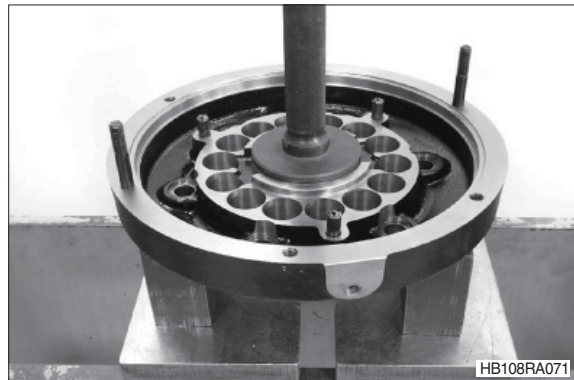

④ Apply sealing agent (loctite #574) to contact face of brake housing /axle drive housing.

※ Area around oil return hole (arrow) must fully be wet.

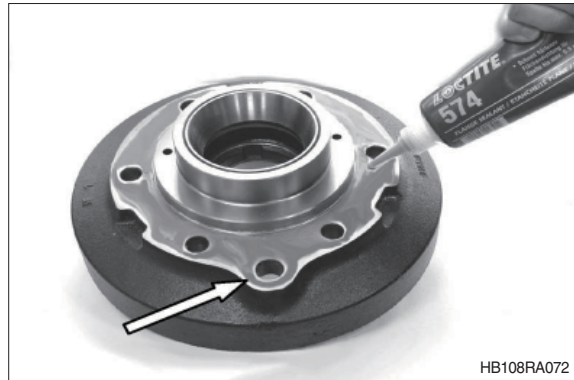

⑤ Mount pre-assembled brake housing and fix with cylinder screws.

※ Ensure a correct installation position regarding oil return hole location.

· Tightening torque (M16/8.8) :
19.9 kgf · m (144 lbf · ft)

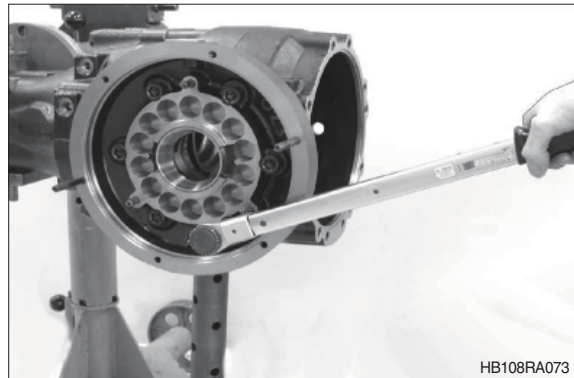

Basic setting of pinion position :

- ① Read dimension I = dimension for production/axle drive housing (from axle center line to bearing contact/inner bearing hole) from brake housing (position-see arrow).

Dimension I e.g. 165.04 mm

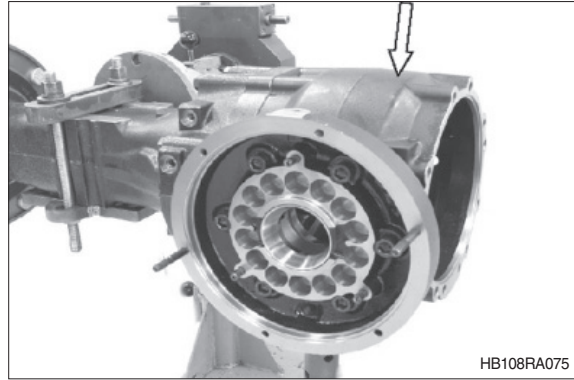

- ② Just for assembly of a **new** brake housing (figure RA075+076) :

Determine dimension X (contact face/ brake housing to locating face tapered roller bearing) of brake housing OLD and brake housing NEW.

- ※ Any difference caused by production must be taken into consideration accordingly in dimension I (see figure RA075).

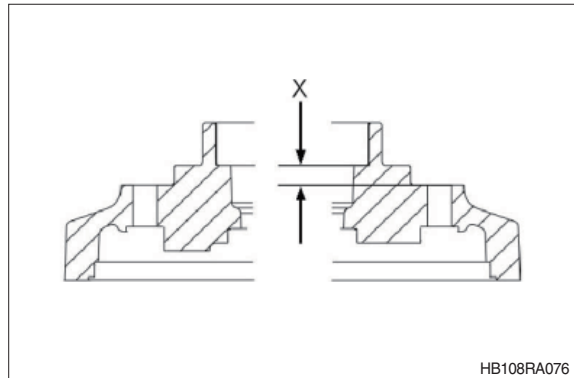

- ③ Read pinion dimension (distance standard dimension = 127.0) from pinion, in case of a + or - deviation of the distance standard dimension caused by production, the actual value is indicated on the pinion.

e.g. :

Pinion dimension - without + or - deviation = 127.0 mm

Pinion dimension - with a ^{+0.1} deviation = 127.1 mm

Pinion dimension - with a ^{-0.1} deviation = 126.9 mm

Dimension II (pinion dimension) e.g.

..... 126.90 mm



- ④ Determine dimension III bearing width, making sure that the rollers are located without clearance (rotate bearing inner ring in both directions several times-roller setting).

Since the installed roller bearing is subject to a preload in installation position, deduct an experience value of -0.05 mm.

Dimension III = e.g. 36.60 mm
-0.05 mm → 36.55 mm

Calculation example e.g. :

Dimension I 165.04 mm

Dimension II + III (126.90+36.55)

..... -163.45 mm

Result = 1.59 mm

Required shim S 1.60 mm

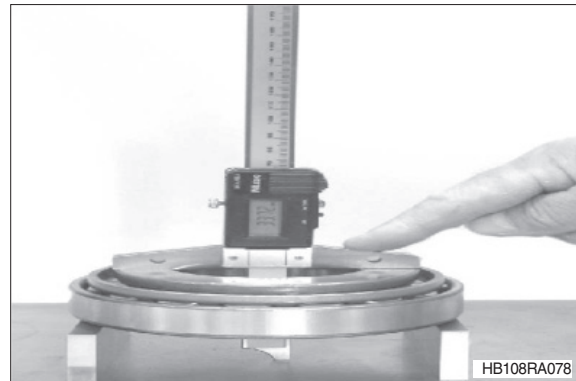

(2) Rolling torque setting of input pinion bearing:

- ① Mount heated bearing inner ring until contact is obtained and readjust after cooling-down.
 Install spacer ring (s = optional).

※ We recommend to reinstall the spacer ring found during disassembly (e.g. s = 16.8 mm).

If the originally mounted shim (contact pattern/bevel gear set) – see page 3-178, figure RA069 – was replaced, also install a spacer ring adjusted by the same correction value.

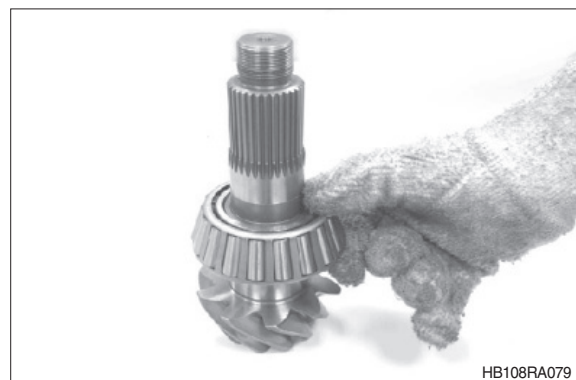

- ※ However, the required bearing rolling torque is decisive, for assembly of:
 - New rolling bearing (without shaft seal) :
0.15~0.31 kgf · m (1.11~2.21 lbf · ft)
 - Old rolling bearing (without shaft seal) :
0.05~0.01 kgf · m (0.36~0.74 lbf · ft)
- Try to achieve upper value.
(Old = reinstalled rolling bearing).
- Any deviation from the required rolling bearing - see bearing rolling torque check (figure RA084) – demands a correction of the bearing rolling torque by a corresponding spacer ring.

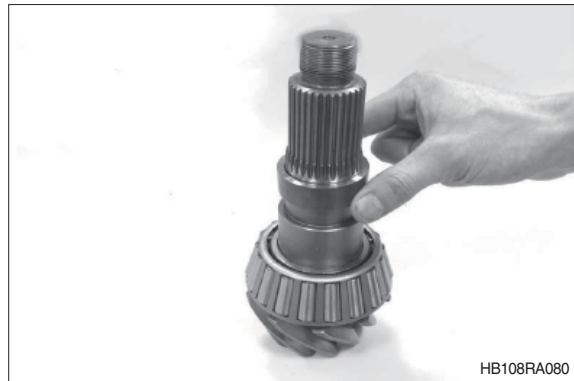

- ② Insert pre-assembled input pinion, mount heated bearing inner ring until contact is obtained.

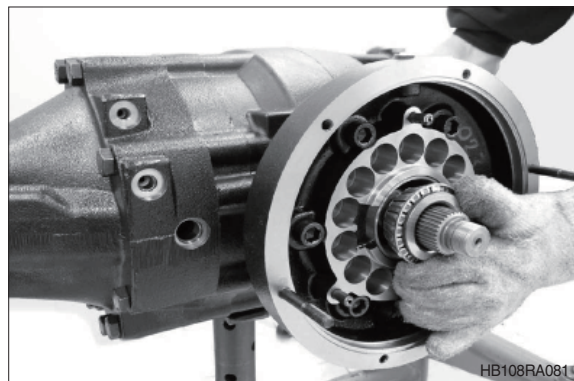

- ③ Mount disc carrier (arrow). Pay attention to installation position.
Install flange.

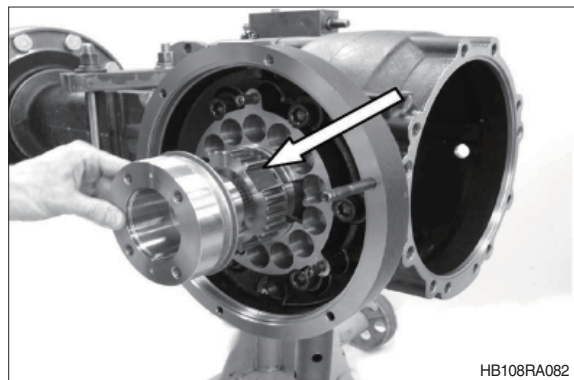

- ④ Fix flange with washer and hexagon nut.
- ※ During tightening rotate pinion in both directions several times (roller setting).
 - Tightening torque (M30 × 1.5) :
61.2 kgf · m (443 lbf · ft)
- Clamping fork 5870 240 025

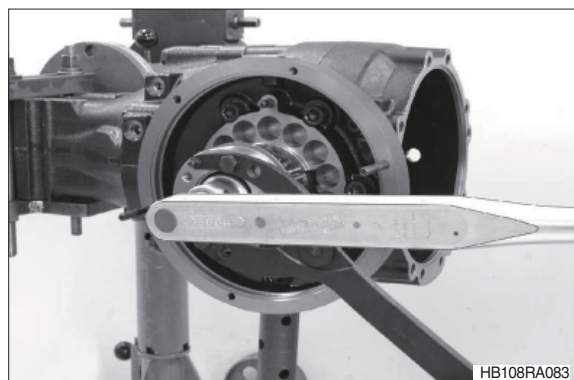

⑤ **Check rolling torque of pinion bearing.**

Required bearing rolling torque when using:

New rolling bearing (without shaft seal) :
0.15~0.31 kgf · m (1.11~2.21 lbf · ft)

Old rolling bearing (without shaft seal) :
0.05~0.01 kgf · m (0.36~0.74 lbf · ft)

**Try to achieve upper value.
(Old = reused roller bearing).**

- ※ Any deviation from the required rolling torque requires a correction by a corresponding spacer ring (see figure RA080, page 3-182).
- ※ If results of contact pattern check are positive, mount shaft seal and input flange according to the descriptions in page 3-208.

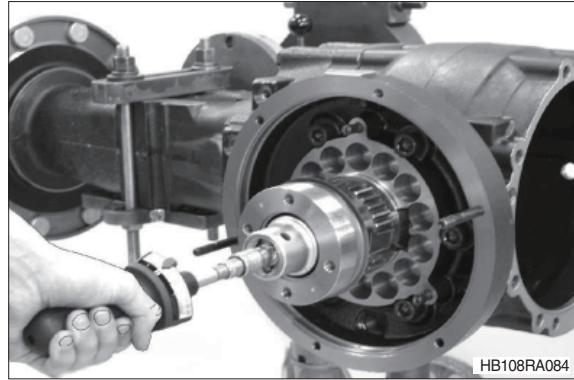

7) REASSEMBLY - DIFFERENTIAL WITH 100% LOCK

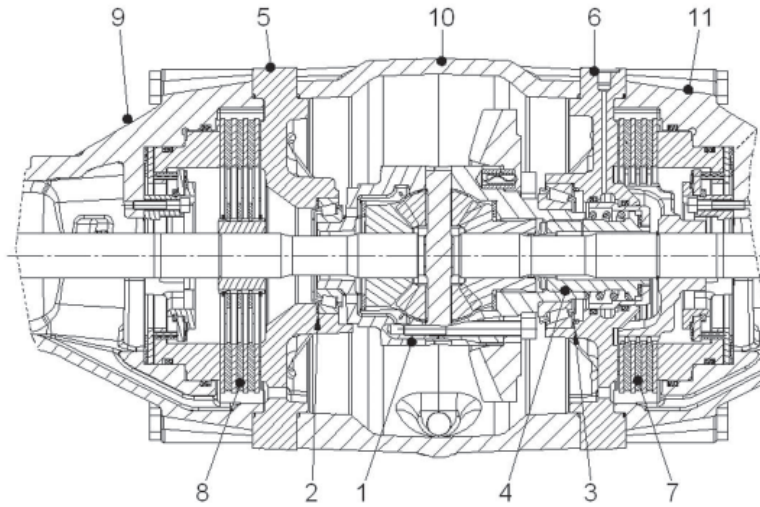

HB108RA085

- | | | |
|---|--|-----------------------|
| 1 Differential | 6 Bearing housing
(crown wheel side) | 9 Axle housing |
| 2 Shim (backlash) | 7 Multi-disc brake - service brake
(crown wheel side) | 10 Axle drive housing |
| 3 Shim (diff. bearing rolling torque) | 8 Multi-disc brake - service brake
(side opposite of crown wheel) | 11 Axle housing |
| 4 Differential lock (100% lock) | | |
| 5 Bearing housing
(side opposite of crown wheel) | | |

- (1) Install slotted pins (arrows) into differential carrier half I – observing the assembly instructions, see figure RA087.

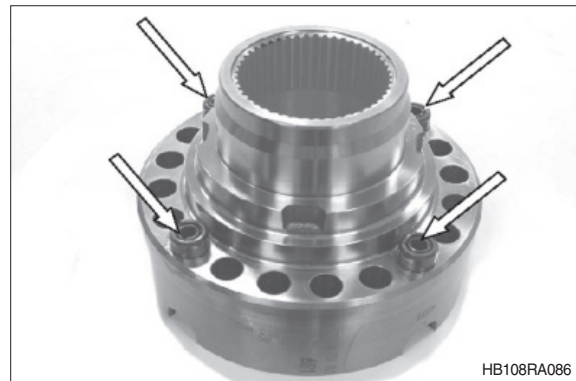

HB108RA086

(2) Assembly instructions:

Locate slotted pin (s) with slot in direction of force (arrow).

In case of double slotted pins - bring the slots in a 180 degrees offset position to each other.

To sketch:

1 = Differential carrier

2 = Slotted pin

3 = Slotted pin (just for version with double slotted pins)

X = Direction of force

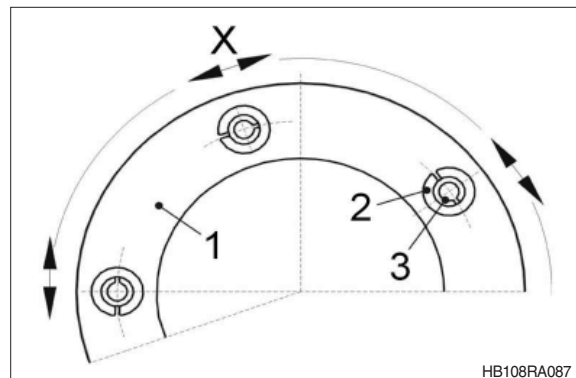

HB108RA087

- (3) Insert thrust washer and axle bevel gear into differential carrier half I.

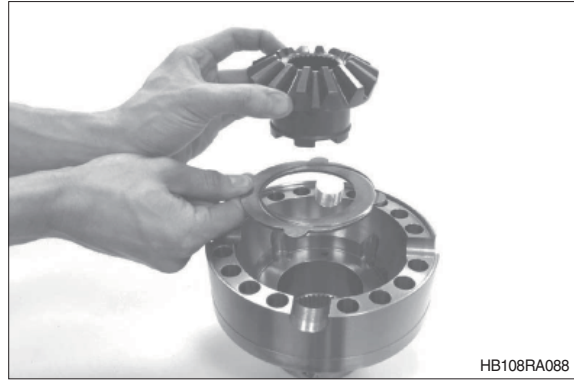

- (4) Legend to sketch

1 = Differential spider
2 = Spider gear
3 = Thrust washer

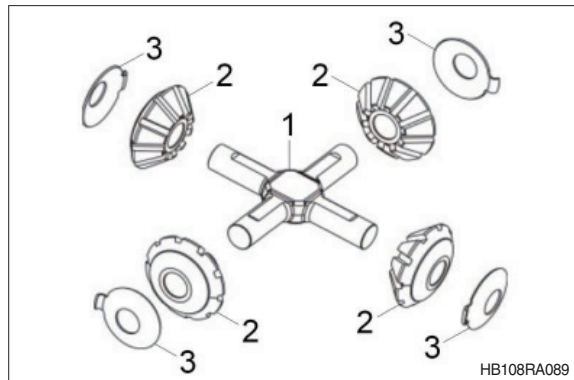

- (5) Mount spider gears and thrust washers on differential spider and insert in differential carrier half I.

※ Ensure radial installation position of thrust washers.
Tab to show straight upwards (see arrows).

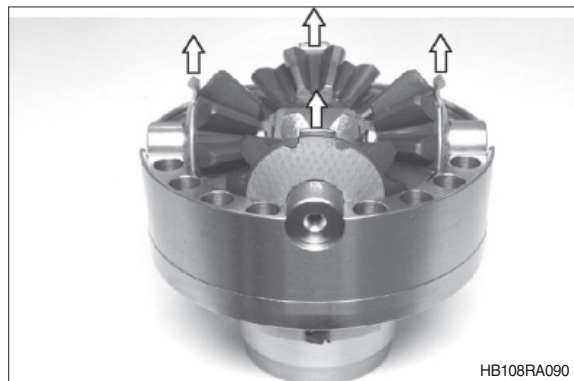

- (6) Position axle bevel gear (arrow) on differential spider.

Fix thrust washer with grease (assembly aid), in differential carrier half II.

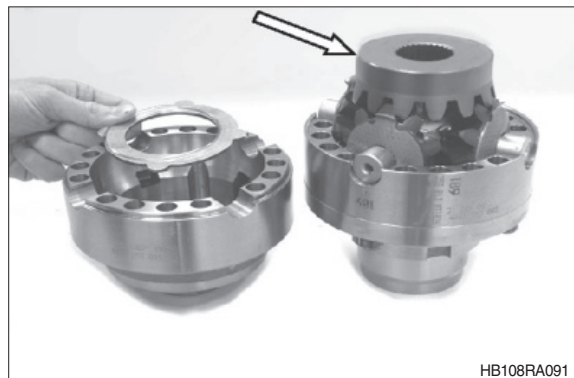

(7) Position pre-assembled differential carrier half II on differential carrier half I.

※ Ensure radial installation of both differential carrier halves – punch-marked no. (see arrow) corresponds to radial position marking.



(8) Position crown wheel on slotted pins and press onto differential carrier until contact is obtained.

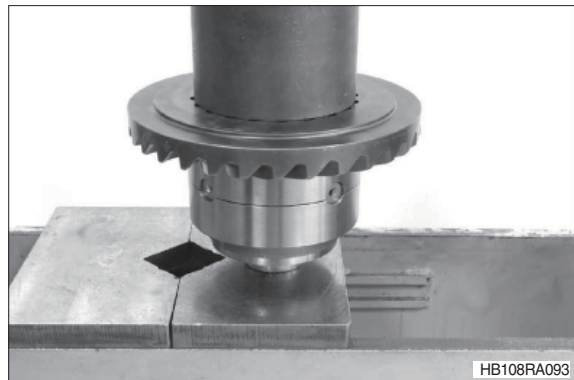

(9) Fix differential by means of a press and connect differential carrier halves with cylinder screws.

· Tightening torque (M 12/12.9) :
13.8 kgf · m (99.6 lbf · ft)

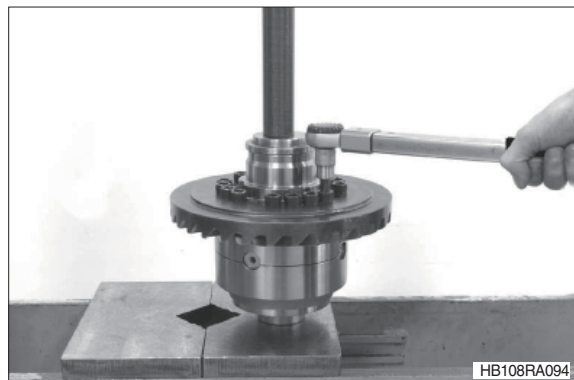

(10) Install both bearing inner rings.

※ Use suitable support (arrow) – differential must not be supported on bearing cage.



- (11) Cover some tooth flanks of crown wheel with marking ink (for contact pattern check – see figure RA106, page 3-190).



- (12) Bring axle into vertical position.
Insert shim (backlash) into hole of axle housing and locate bearing outer ring until contact.
We would recommend to reinstall the shim found during disassembly – refer to disassembly instructions page 3-170, figure RA045 - (e.g. $s = 1.70 \text{ mm}$)

※ The required backlash, however, is decisive for the shim (s), to be used – see figure RA103, page 3-189.

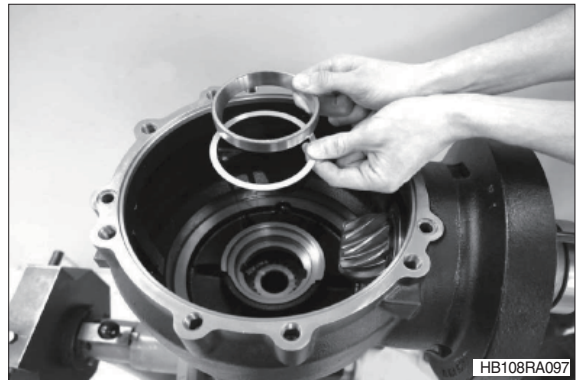

- (13) Insert preassembled differential.

Internal extractor	5870 300 019
Eye nut	5870 204 027

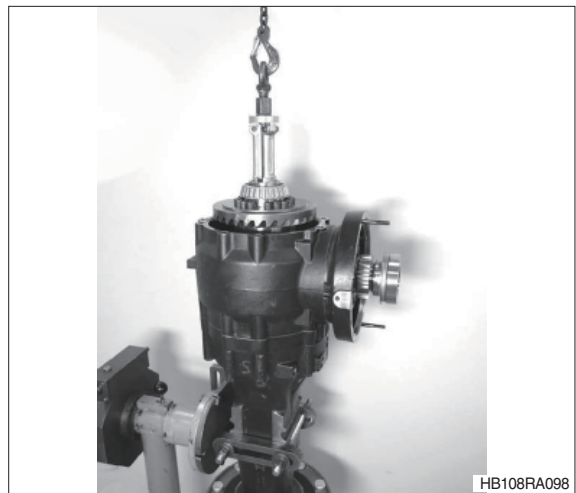

(14) Position bearing outer ring on bearing inner ring, until all rollers are located without clearance.

※ For the following determination of dimension pay attention to an exact contact of the bearing outer ring and a correct positioning of the differential.

Determine dimension A - from mounting face/axle drive housing to front face/bearing outer ring (take measurements at several points and find out mean value).

Dimension I e.g. 6.64 mm

Straightedge 5870 200 022

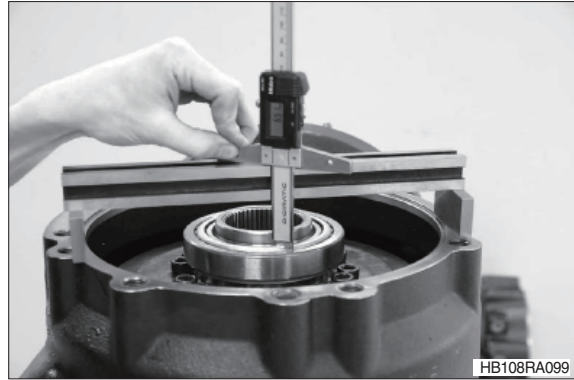

HB108RA099

(15) Determine dimension II – from mounting face /bearing housing to bearing hole/ bearing outer ring contact.

Dimension Z e.g. 5.35 mm

Calculation example :

Dimension I e.g. 6.64 mm

Dimension II e.g. - 5.35 mm

Difference 1.29 mm

Bearing preload + 0.10 mm

Result = 1.39 mm

Required shim (s) = 1.40 mm

※ A bearing preload of 0.10 mm corresponds to a bearing rolling torque of approximate 0.10~0.41 kgf · m (0.72~2.95 lbf · ft), if new bevel roller bearings are used.

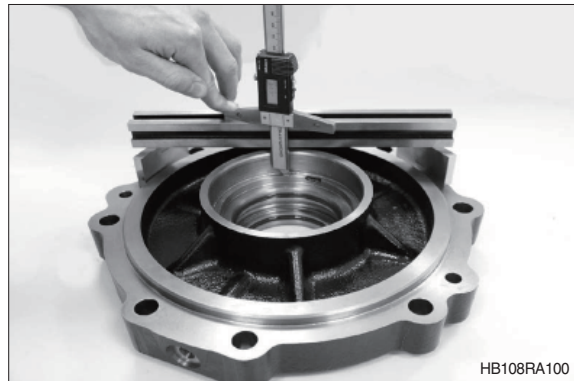

HB108RA100

(16) Insert determined shim (e.g. s = 1.40 mm) into hole of bearing housing and locate bearing outer ring until contact.



HB108RA101

(17) Mount preassembled bearing housing (without O-rings). Bring it to contact position and fix provisionally with hexagon screws (3x with washer, L = 70 mm).

※ Rotate differential in both directions several times – roller setting (also see below figure).

· Tightening torque (M16/8.8) :
19.9 kgf · m (144 lbf · ft)

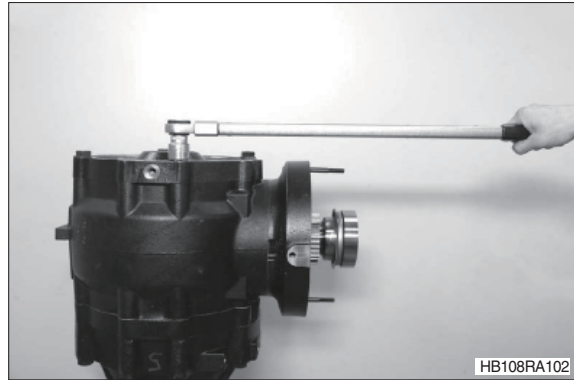

Check of backlash and of bevel gear set contact pattern:

(18) Insert cylinder screw (2) into internal extractor (1) and fix straightedge (3) and internal extractor in the hole of the differential carrier.

※ Internal extractor must not be positioned in the axle bevel gear.

Internal extractor	5870 300 019
Cylinder screw (M20)	0636 101 468
Straightedge	5870 200 087

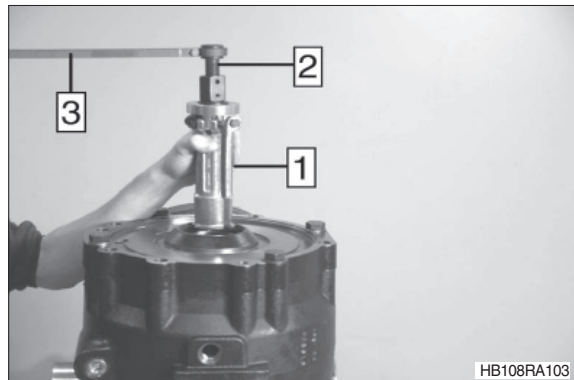

(19) Place dial indicator (3) at right angles to the straight edge (1) within a distance corresponding to the outer diameter of the crown wheel (r = approx 126 mm) –and check backlash.

Backlash 0.15~0.25

※ Any deviation from the required backlash requires its correction with corresponding shim (s) - see figure RA097, page 3-187. A correction of the shim/backlash also requires a counter-correction of shim/diff bearing rolling torque - see figure RA101.

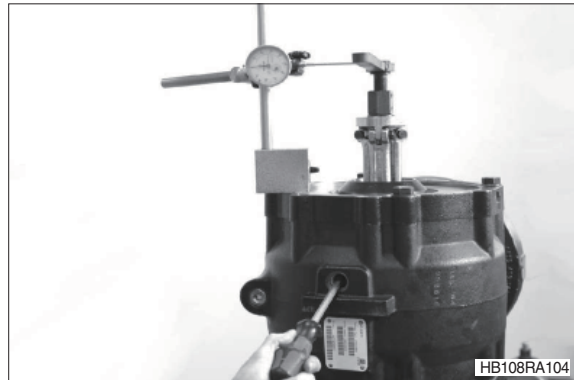

(20) For contact pattern check, roll input pinion against crown wheel in both directions (drive and coast side engagement).

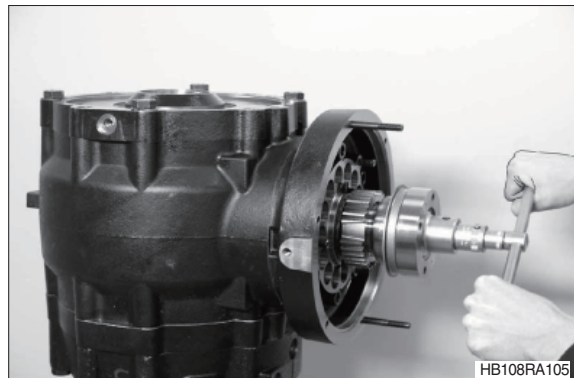

(21) Remove differential again.

Compare contact pattern with contact pattern examples on page 3-213.

- ※ If contact pattern differs considerably, use a corresponding shim (see figure RA069, page 3-178) for correction.

A correction of the shim/contact pattern also influences the backlash – check once again (see figure RA104).



(22) Place sun gear shaft and stub shaft into the planetary carrier (output opposite to crown wheel).

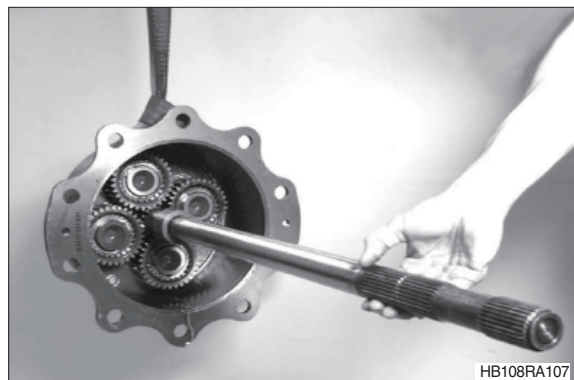

(23) Mount planetary carrier, and insert stub shaft into the planetary carrier (service brake).

- ※ Pay attention to mounted O-ring (arrow).

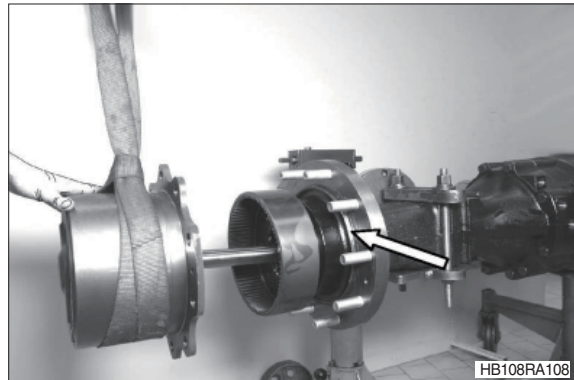

(24) Fix planetary carrier with hexagon screws.

- ※ Insert hexagon screws with locking compound (loctite #243).

- Tightening torque (M12/8.8) :
5.61 kgf · m (40.6 lbf · ft)

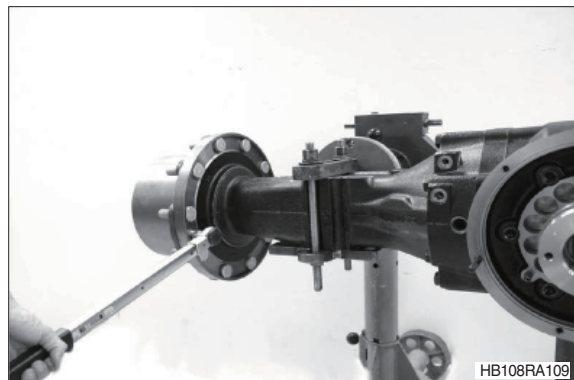

(25) Relocate differential, and insert stub shaft into the axle bevel gear.

Internal extractor 5870 300 019

Eye nut 5870 204 027

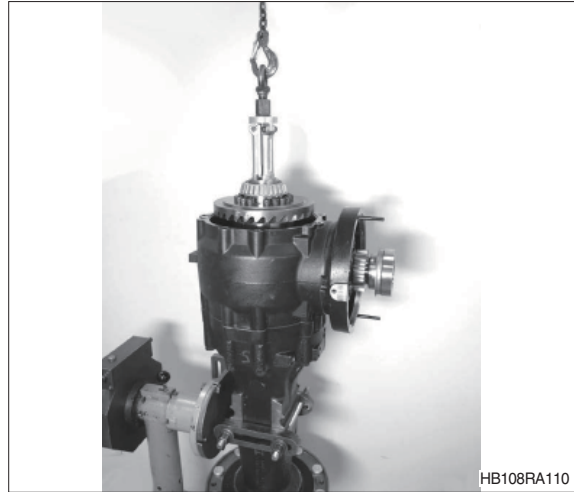

HB108RA110

(26) Install adjusting screws (1) and fix both O-rings (2) with grease (assembly aid) into the countersinks of the axle drive housing.

Adjusting screws/M16 (1 set = 2 pcs.)

5870 204 053

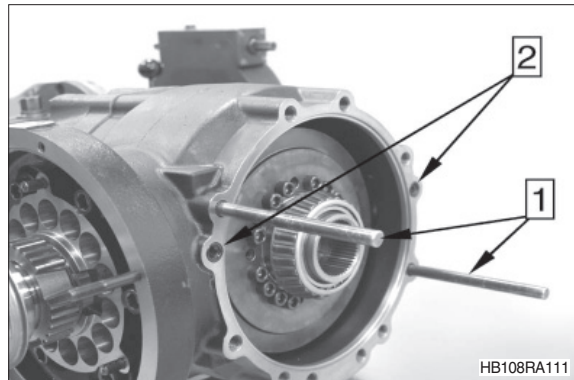

HB108RA111

(27) Insert locking slide with mounted compression spring.

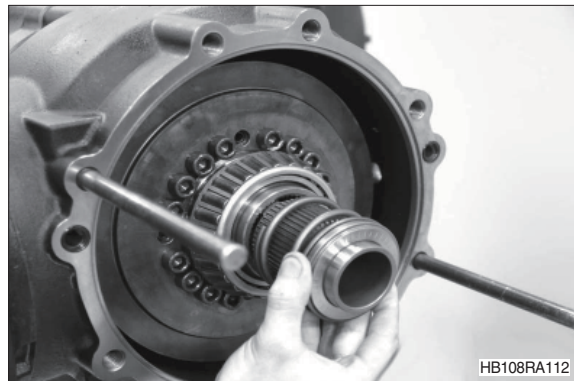

HB108RA112

(28) Mount axial needle cage on locking slide. Fix axial needle cage with grease – assembly aid.

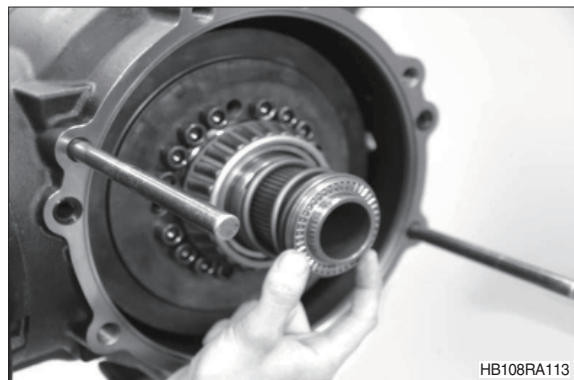

HB108RA113

(29) Oil both grooved rings (1 + 2) and place into annular grooves of the bearing housing – paying attention to the installation position (see detailed sketch).
Install O-ring (3).

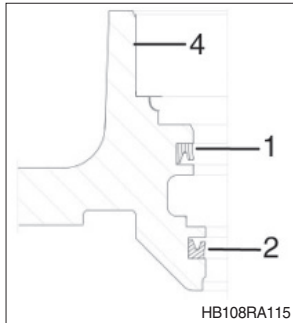

- 1 = Grooved ring
- 2 = Grooved ring
- 3 = O-ring
- 4 = Bearing housing

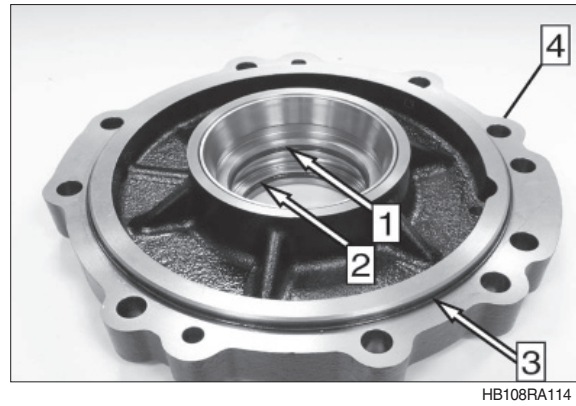

(30) Oil sealing surface and insert piston.



(31) Press piston to contact position.



(32) Mount preassembled bearing housing.

※ Check leakage of 100% lock.
- See page 3-199, figure RA141.

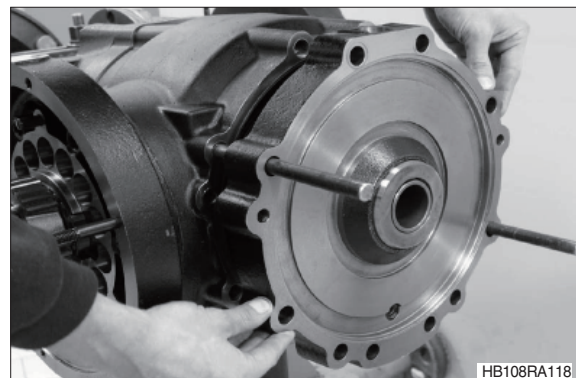

8) ASSEMBLY - SERVICE BRAKE (multi-disc brake)

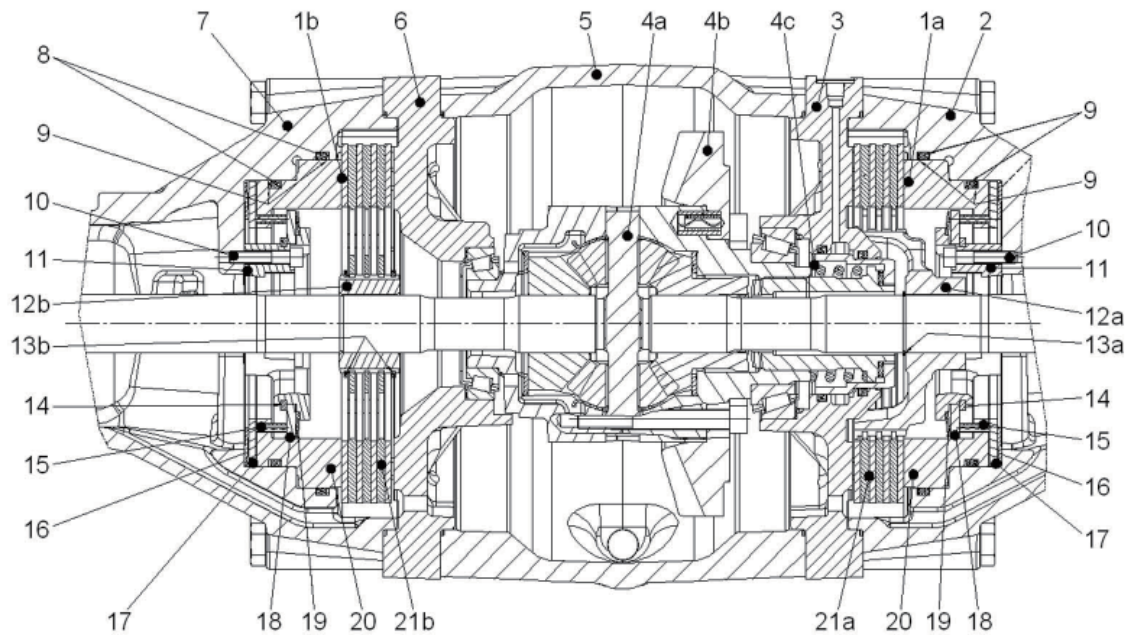

HB108RA119

- | | | | |
|----|------------------------------------|-----|-----------------------|
| 1 | Service brake (multi-disc brake) | 12 | Disc carrier |
| 1a | Crown wheel side (CS) | 12a | Disc carrier (CS) |
| 1b | Side opposite of crown wheel (SOC) | 12b | Disc carrier (SOC) |
| 2 | Axle housing (CS) | 13 | Retaining ring |
| 3 | Bearing housing (CS) | 13a | Retaining ring (CS) |
| 4 | Differential assy | 13b | Retaining rings (SOC) |
| 4a | Differential | 14 | Retaining ring |
| 4b | Crown wheel | 15 | Slotted pin |
| 4c | 100% lock | 16 | Cup spring |
| 5 | Axle drive housing | 17 | Washer |
| 6 | Bearing housing (SOC) | 18 | Washer |
| 7 | Axle housing (SOC) | 19 | Cup spring |
| 8 | Grooved ring | 20 | Piston |
| 9 | Back-up ring | 21 | Disc package |
| 10 | Cylinder screw | 21a | Disc package (CS) |
| 11 | Ring | 21b | Disc package (SOC) |

※ Below, the reassembly of the service brake on the axle housing (CS = crown wheel side) is shown. For reassembly of the service brake on the other axle housing (SOC = side opposite of crown wheel) proceed in the same way.

(1) Insert sealing elements (2+3 – see below sketch) into annular groove (arrow) of the axle housing.

※ Pay attention to installation position of the sealing elements.

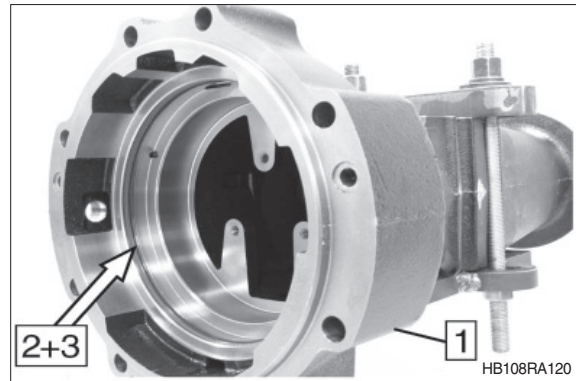

- (2) 1 = Axle housing
- 2 = Back-up ring
- 3 = Grooved ring
- 4 = Grooved ring
- 5 = Back-up ring
- 6 = Piston
- 7 = Slotted pins

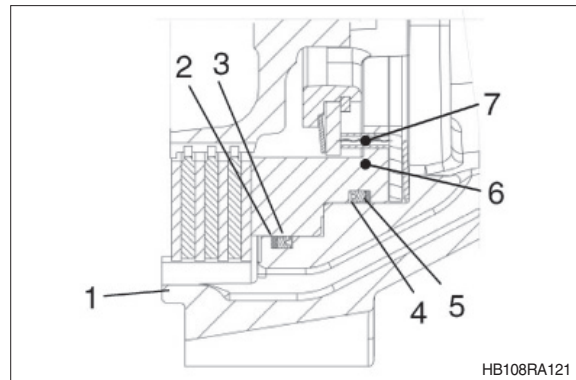

(3) Insert sealing elements (4+5 – see sketch) into annular groove (arrow) of piston (6).

※ Pay attention to installation position of sealing elements.

Flush-mount slotted pins (7) (front face) into piston (6), or relocate – if not dismantled.

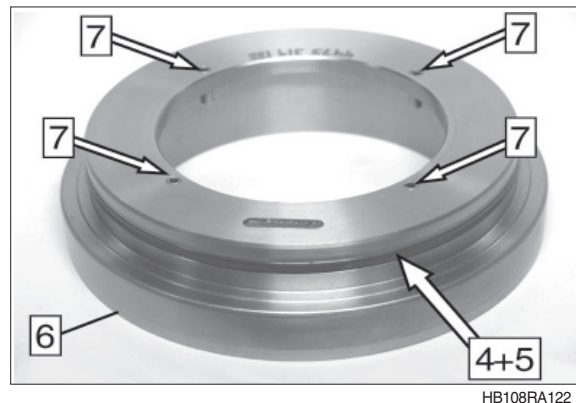

- (4) 1 = Axle housing
- 2 = Cup spring
- 3 = Washer
- 4 = Piston
- 5 = Ring
- 6 = Cup spring
- 7 = Washer
- 8 = Retaining ring

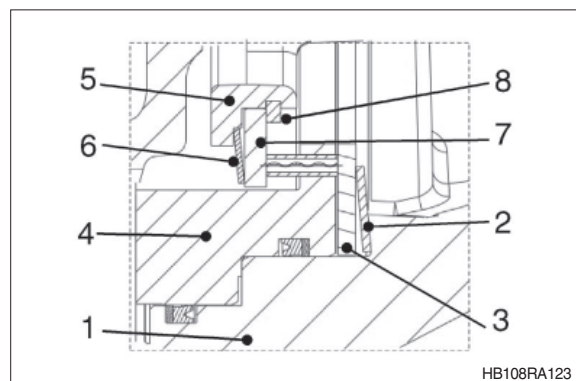

- (5) Locate cup spring (2) – **paying attention to correct installation position (see sketch RA123)** - and washer (3) into axle housing (1).

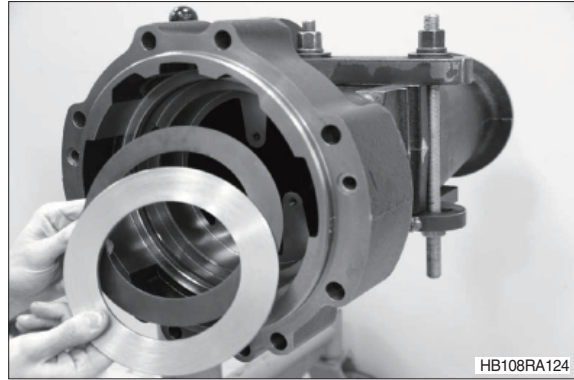

- (6) Oil grooved rings and sealing surfaces of axle housing and piston.
Mount pre-assembled piston (1).

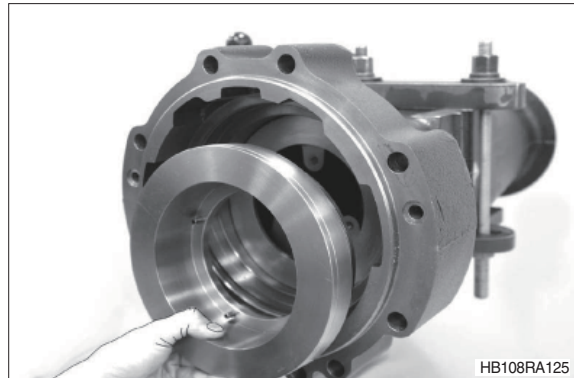

- (7) Push piston to contact position using a two-armed puller and a pressure plate.
※ Pay attention to the slotted pins placed in the piston.
Ensure that position of located slotted pins does not change – pressure plate may only touch piston front face.

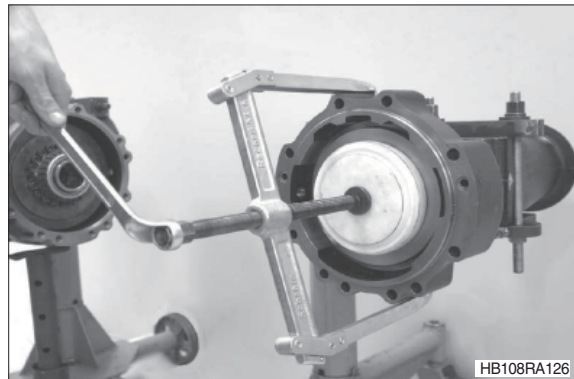

- (8) Mount cup spring (6) – **paying attention to correct installation position (see sketch RA123)** - and washer (7) on ring (5).



- (9) Press down cup spring preload using a press, and snap in retaining ring (8).

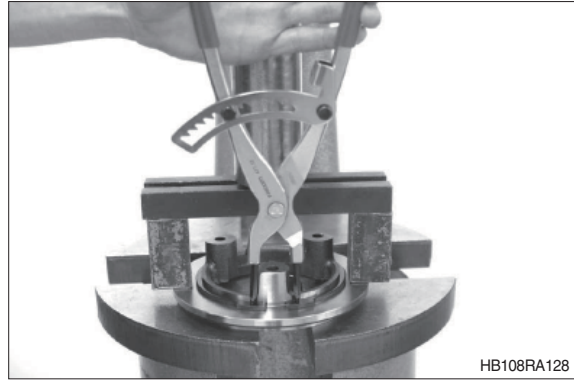

- (10) Insert preassembled ring and fix with cylinder screws.

※ Install cylinder screws with locking compound (loctite #262).

- Tightening torque (M8/8.8) :
2.35 kgf · m (17 lbf · ft)

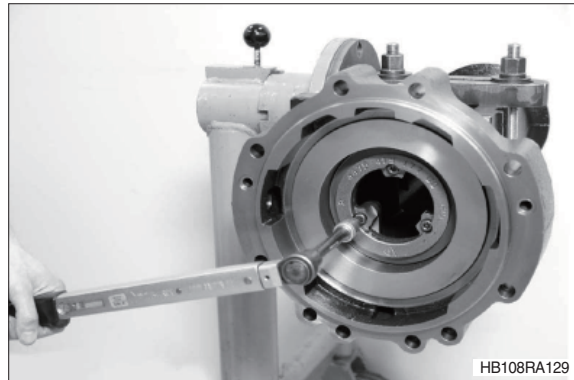

- (11) 1 = Outer discs
2 = Inner discs (lined discs)

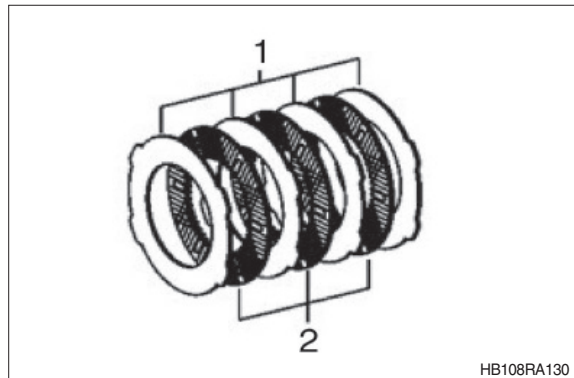

- (12) Locate disc package – **taking the disc arrangement into consideration (see sketch above).**

※ Fix outside disc with grease – assembly aid.

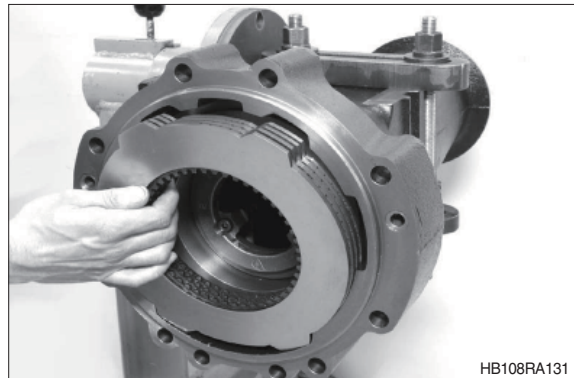

- (13) Mount disc carrier – **paying attention to correct installation position (see figure)** –and snap in retaining ring.



- (14) Insert pre-assembled stub shaft until all inner discs are mounted.

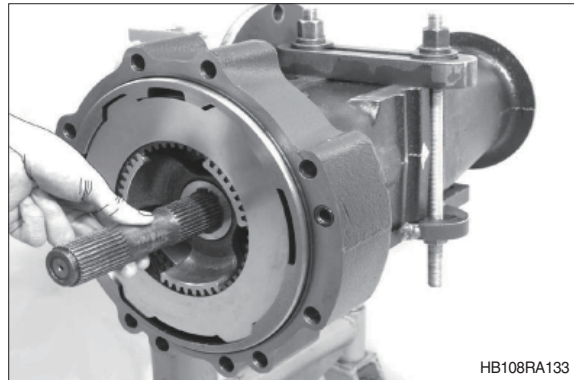

- (15) Mount sun gear shaft to inserted stub shaft – assembly aid (for central position of stub shaft).

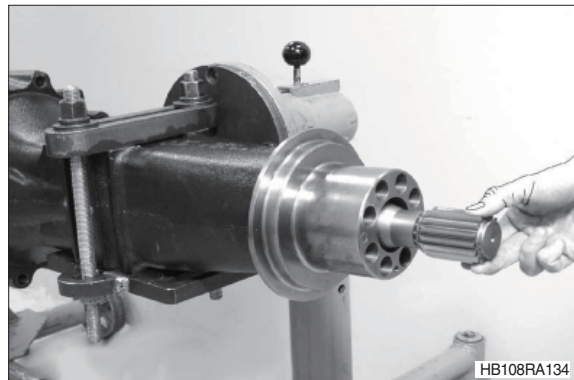

- (16) Fix both O-rings (1) with grease (assembly aid) into countersinks of the axle housing.
Oil O-ring (2) and install on the axle housing.

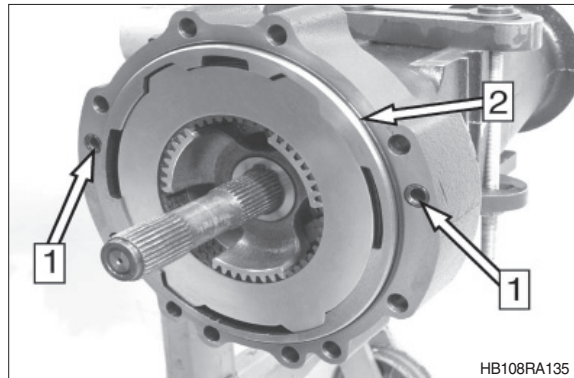

(17) Take up cpl. axle half by means of a lifting strap and position it on bearing housing/ axle drive housing – and insert stub shaft into gearing of the axle bevel gear (differential).

- ※ Pay attention to O-rings installed in the axle drive housing (see page 3-191, figure RA111) and in the axle housing (page 3-197, figure RA135).

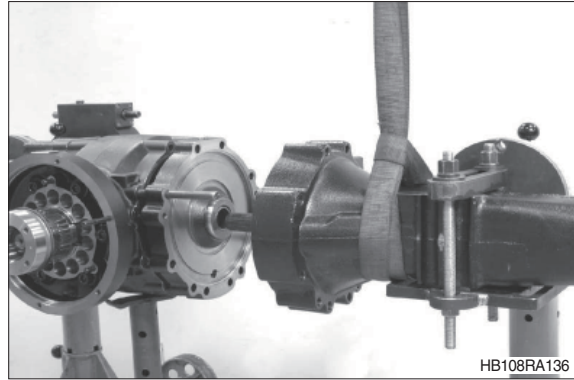

HB108RA136

(18) Bring axle housing equally to contact position and fix it by means of hexagon screws.

- ※ Rotate differential in both directions several times – roller setting.
 - Tightening torque (M 16/8.8) :
19.9 kgf · m (144 lbf · ft)

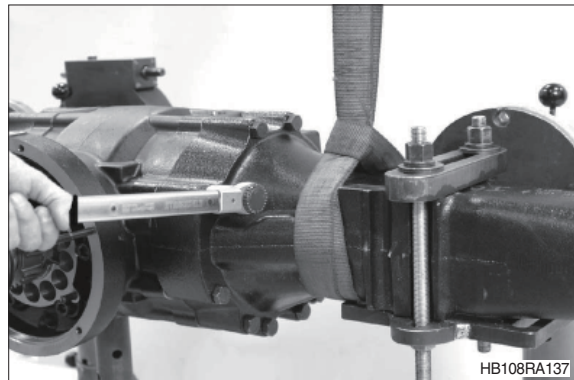

HB108RA137

Leakage test of multi-disc brake

- ① Mount breather valve (arrow) and connect HP-pump.

HP pump	5870 287 007
Threaded coupling (9/16"-18UNF)	5870 950 115
Oil collector bottle	5870 286 072

- ※ Completely breathe brake prior to test start.

Leakage test:

Build up test pressure $p = 60 \text{ bar} - 10 \text{ bar}$ and close shut-off valve of HP pump (maintain pressure).

A pressure drop of max 3 bar is allowed during a 2 minute testing time.

Test media:

Motor oils SAE-10W ;
API-SE,
ATF-oils : Dexron of II D



HB108RA138

Disc clearance test of service brake:

※ The brake must fully be breathed for obtaining an objective test result of the disc clearance.

- ① Pressurize brake by HP pump with $p = 60 \text{ bar} - 10 \text{ bar}$, then release brake and check disc clearance X using a feeler gauge – also refer to the next sketch.

Disc clearance X nom. = 0.4 ~ 0.75 mm

※ If the required disc clearance X is not obtained, assembly was not carried out properly, and another disassembly and reassembly is imperative.

HP pump	5870 287 007
Threaded coupling (9/16"-18UNF)	5870 950 115
Feeler gauge	5870 200 113

1 = Piston
2 = Outer disc
3 = Inner disc (lined disc)
 X = Disc clearance (0.4 ~ 0.75 mm)

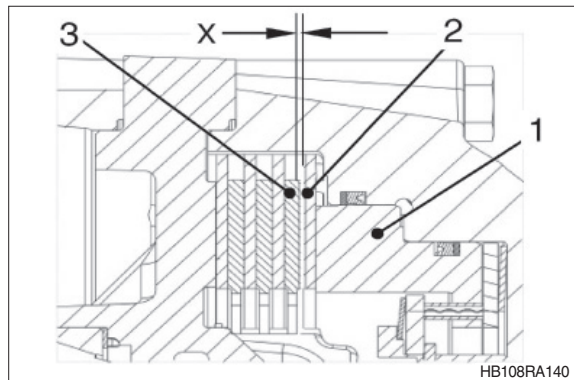

Leakage test of differential lock (100% lock) :

- ① Prior to starting the test, bleed pressure chamber and then check 100% lock.

Test:

Build up test pressure $p = 13 \text{ bar}$ and close shut-off valve of HP pump.

※ No pressure drop is allowed during a 2 minute testing time.

HP pump	5870 287 007
Threaded coupling (7/16-20 UNF)	5870 950 135

Test media:

Motor oils SAE-10W ;
API-SE,
ATF-oils : Dexron of II D

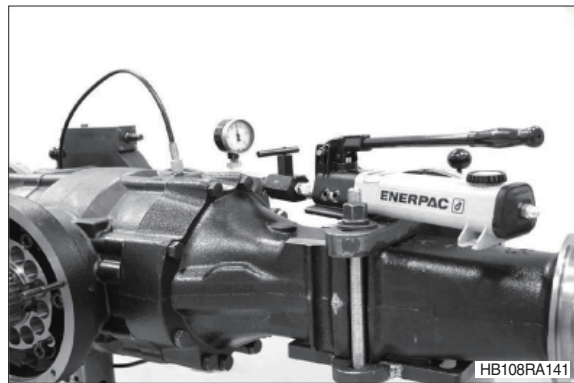

9) DISASSEMBLY - OUTPUT UNIT

- 1 = Axle housing
- 2 = Hub
- 3 = Shaft seal
- 4 = Roller bearing (hub bearing)
- 5 = Internal gear
- 6 = Planetary gears
- 7 = Planetary carrier
- 8 = Sun gear shaft

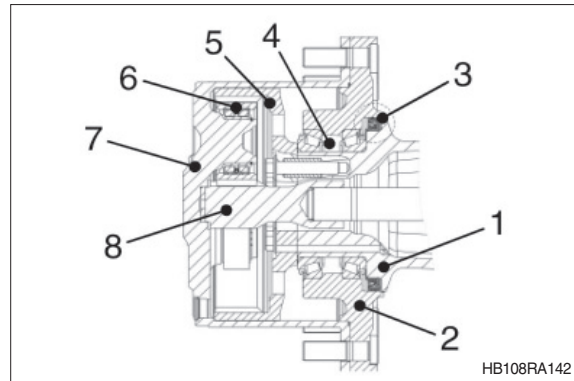

(1) Mount wheel bolt.

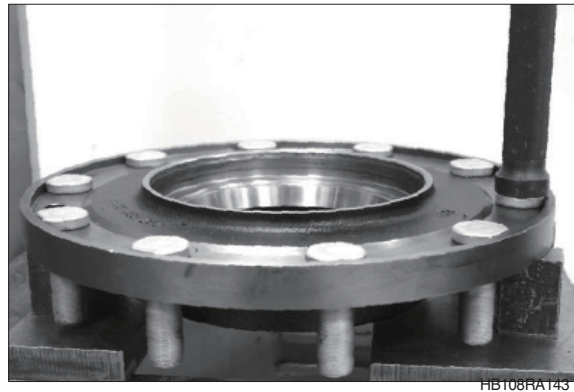

(2) Install both bearing outer rings of hub bearing until contact is obtained.

※ Hub must not be supported on wheel bolts.

Driver tool 5870 051 012
Handle 5870 260 004

※ To ensure functioning, always use a new shaft seal when reassembling the hub – also refer to disassembly instructions page 3-161, figure RA015.

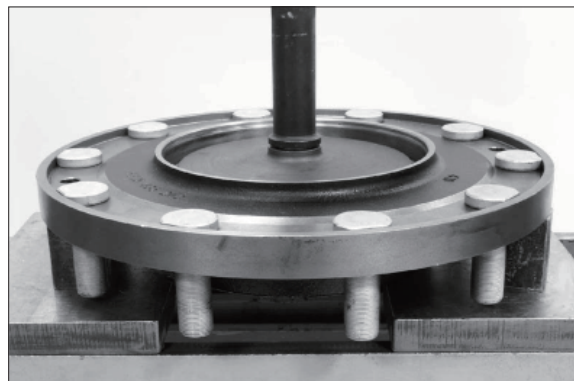

(3) Apply sealing agent to contact face shaft seal/hub (loctite #574).

Mount shaft seal observing the correct installation position (labeling OUT-SIDE showing upwards / outwards) and the correct offset X –see detailed sketch.

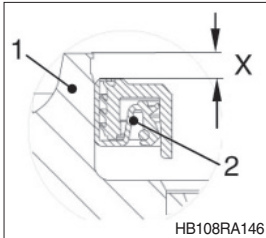

1 = Hub
2 = shaft seal
X = installation dimension 5^{+1} mm

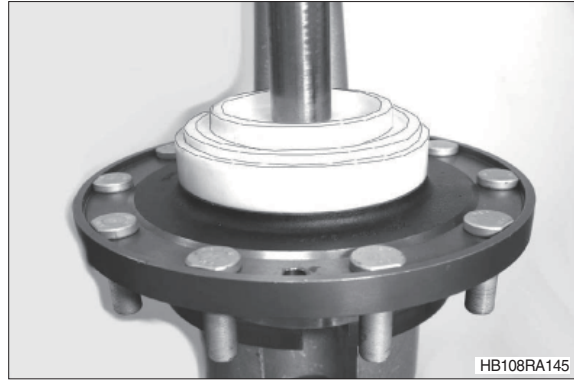

Driver tool

5870 051 057

(4) Mount heated bearing inner ring until contact.

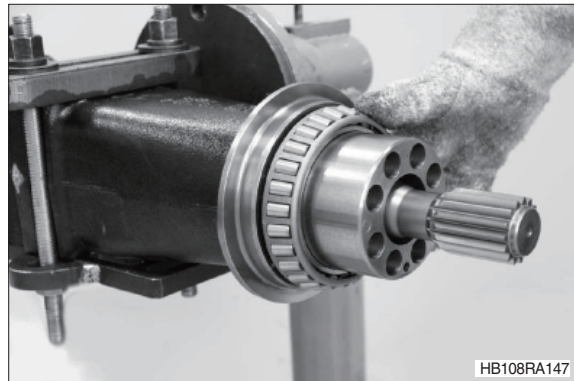

※ Just before fitting, wet the contact face shaft seal/axle housing with spirit – assembly aid.

(5) Mount preassembled hub until contact and fix it with heated external bearing inner ring.

Lifting bracket

5870 281 043



- (6) If disassembled – insert bushings into the internal gear until contact is obtained.

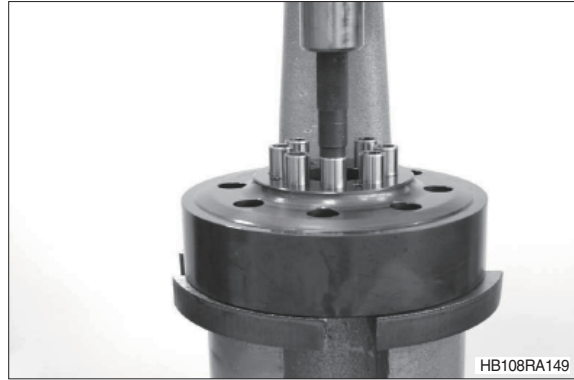

- (7) Mount preassembled internal gear and equally bring to contact position using the **old** locking screws (from disassembly).
 ※ Rotate hub in both directions several times – roller setting.

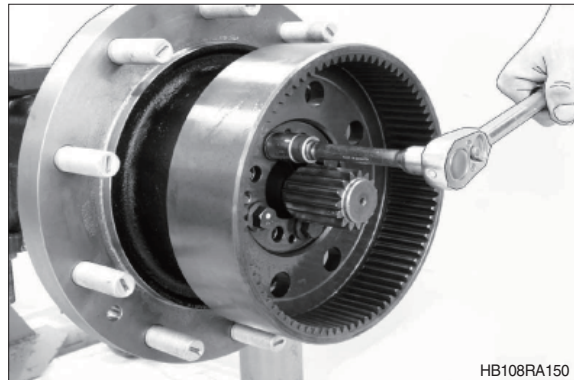

- (8) Finally fix internal gear with **new** locking screws.

▲ **Locking screws are permitted for one-time use only.**

- Tightening torque (M14/12.9) :
 25.5 kgf · m (184 lbf · ft)

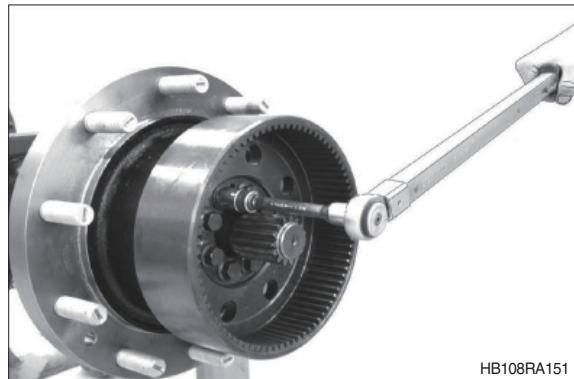

- (9) Just for new parts assembly:
 Insert cylinder roller bearing into the planetary gear – by pressing the roller bearing into the planetary gear by the assembly sleeve (arrow) until the snap ring engages into the annular groove of the planetary gear.

- 1 = Planetary gear
- 2 = Roller bearing (with bearing inner ring /cylinder rollers/axial washers and snap ring)
- 3 = Assembly sleeve

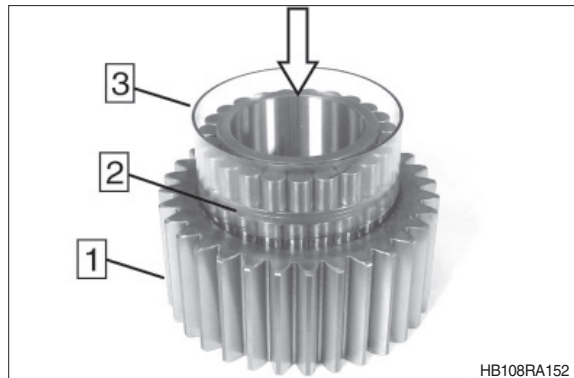

(10) Heat preassembled planetary gear (bearing inner ring) and install until contact, with large radius /bearing inner ring showing downwards (arrow).

※ Adjust bearing inner ring/planetary gear after cooling down.

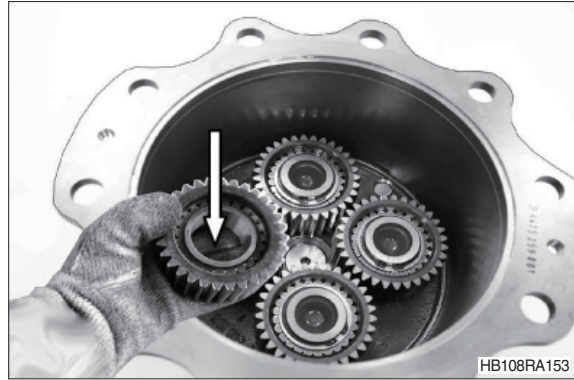

(11) Snap in retaining ring.

▲ Check contact position of retaining ring on groove base and readjust.

※ For assembly of the other planetary gears proceed in the same way.



(12) If disassembled – install stop pin (arrow).

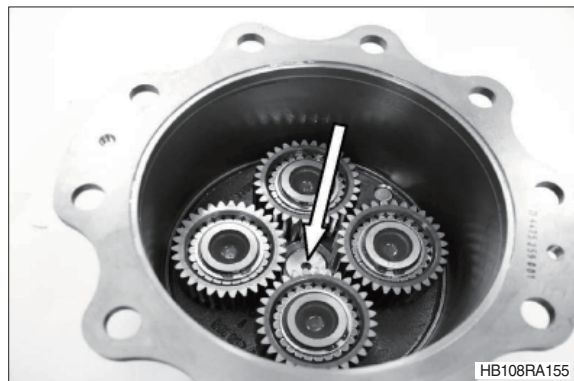

(13) Oil O-ring (arrow-1) and install on collar of hub.

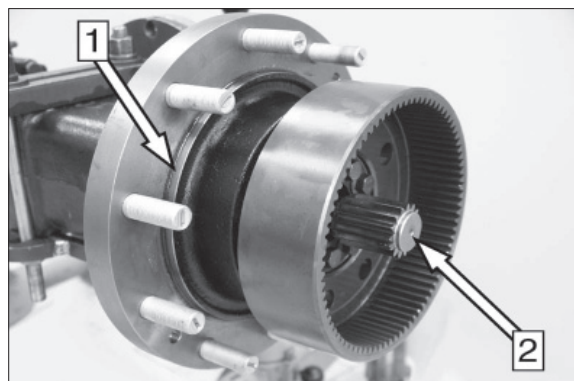

- (14) Take sun gear shaft (see arrow -2 / figure RA156) out of axle housing and insert in the preassembled planetary carrier – assembly aid.

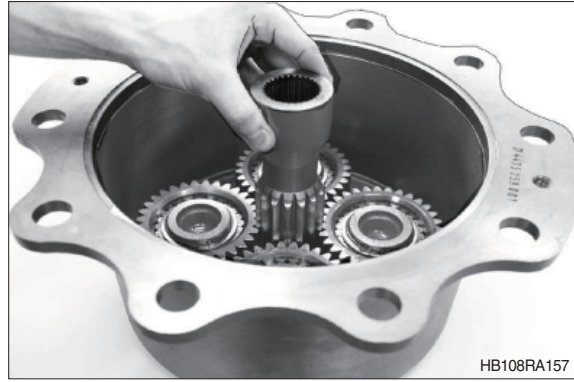

- (15) Take up preassembled planetary carrier by means of lifting strap and mount it on the hub –installing stub shaft into sun gear shaft.

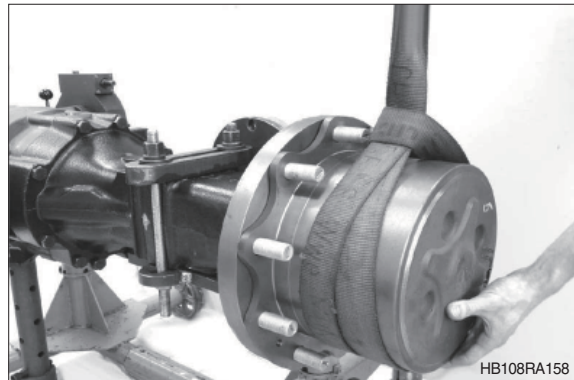

- (16) Fix planetary carrier with hexagon screws.

※ Insert hexagon screws with locking compound (loctite #243).

· Tightening torque (M12/8.8) :
5.61 kgf · m (40.6 lbf · ft)

※ Prior to putting into operation fill the axle with oil.

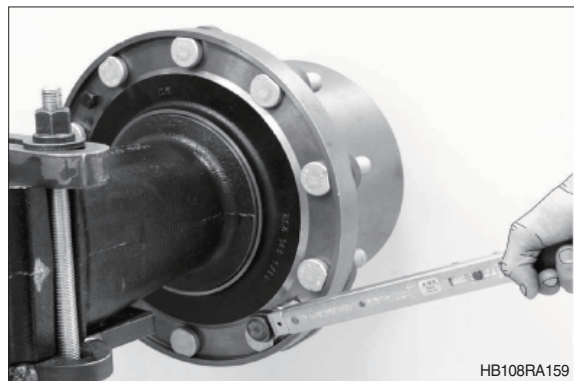

10) REASSEMBLY

PARKING BRAKE (multi-disc brake)

For reassembly of the brake housing (1) see reassembly description of the input pinion – page 3-178~180.

- (1) Insert all compression springs (2+3) into the holes of the brake housing (1).

Just for assembly of new parts, or if dismantled:

- ※ Install slotted pins (4) – with slots of slotted pins in a 180° offset position – and stud bolts (5).
- ※ Insert stud bolts with locking agent (loctite #262).

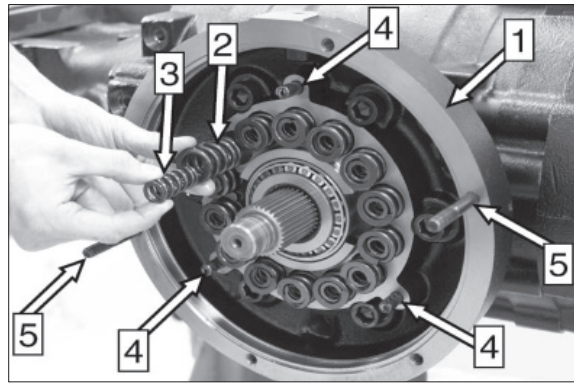

HB108RA160

1 = Brake housing cover

2 = Grooved ring

3 = Grooved ring

4 = Piston

5 = Bolt

6 = O-ring

7 = Hex. screw

8 = Hex. nut

9 = O-ring

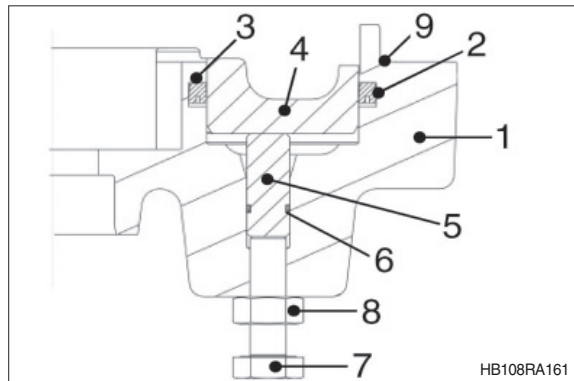

HB108RA161

- (2) Oil both grooved rings (arrow) and insert them into the brake housing cover – observing the installation position, see sketch RA161.

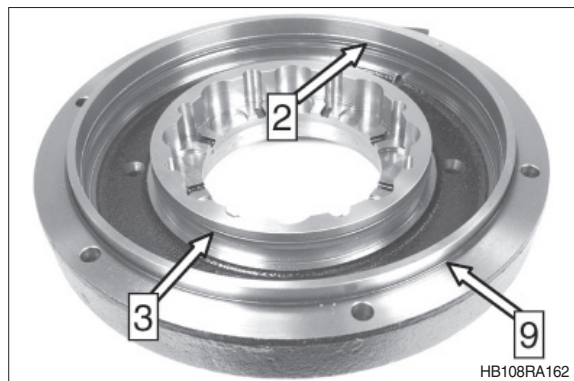

HB108RA162

- (3) Insert both bolts (arrows) with O-ring into the brake housing cover – **observing the installation position, see sketch RA161.**

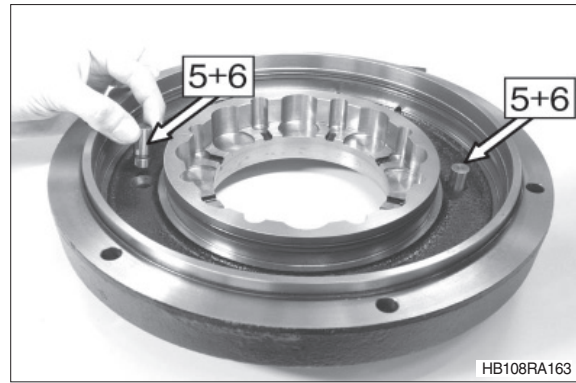

- (4) 1 = Outer discs (steel discs)
2 = Inner discs (lined discs)

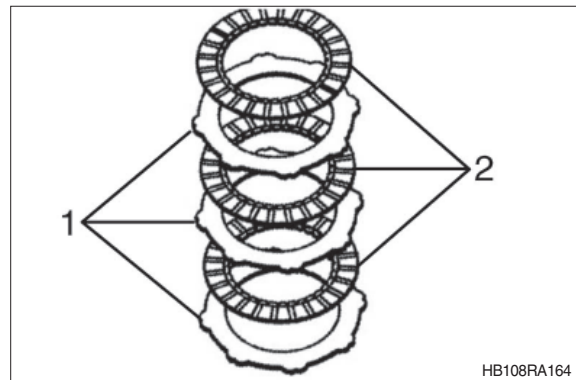

- (5) Insert disc package into the brake housing cover – **observing the disc arrangement (see sketch above) starting with an outer disc.**



- (6) Oil sealing surface of piston and of brake housing cover and press piston into the brake housing cover to contact position.

- ※ Press in piston without tilting – risk of damage to grooved rings and piston.

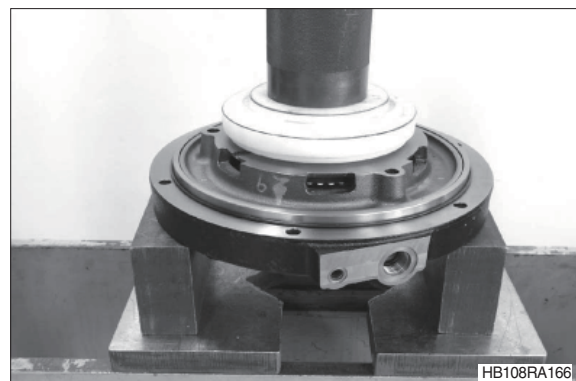

- (7) Mount preassembled brake housing cover and fix with hexagon nuts (arrows).

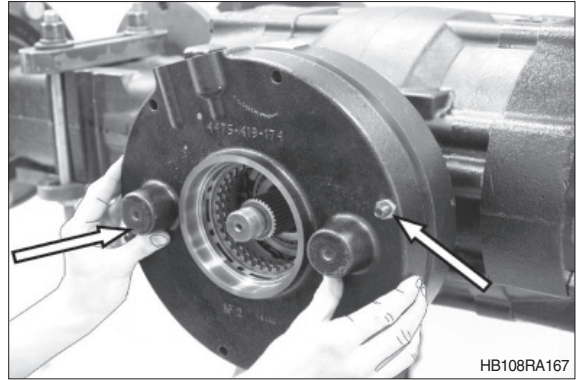

- (8) Insert disc carrier so that all discs (inner discs) are mounted.

- ※ Ensure a correct installation position of the disc carrier – countersink/input flange contact to show outwards (arrow).

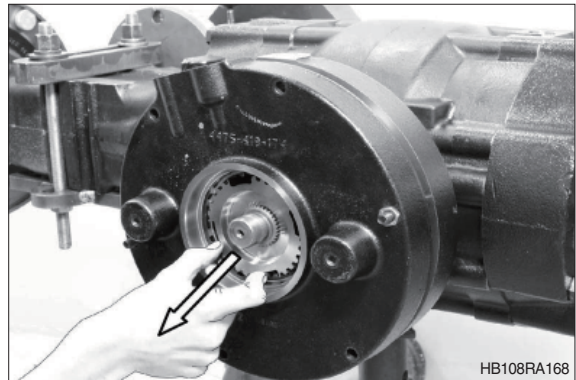

- (9) Bring brake housing cover to contact position **evenly** by hexagon nuts and hexagon screws, then fix it finally.

- ※ Hereby install disc carrier accordingly, to ensure all inner discs remain mounted.

- Tightening torque (M10/8.8) :
4.69 kgf · m (33.9 lbf · ft)

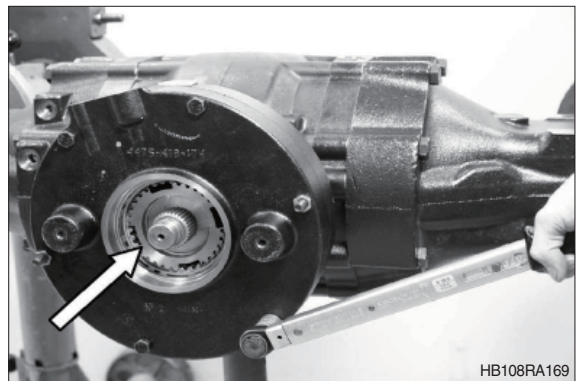

Shaft seal/input flange

1 = Brake housing cover

2 = Shaft seal

3 = Screen sheet

4 = Input flange

5 = Washer

6 = Hex nut

7 = Input pinion

Z = detailed sketch – installation dimension/shaft seal

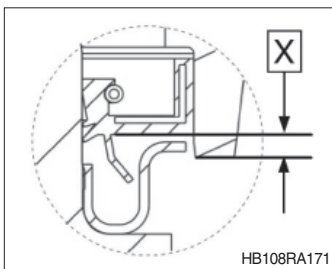
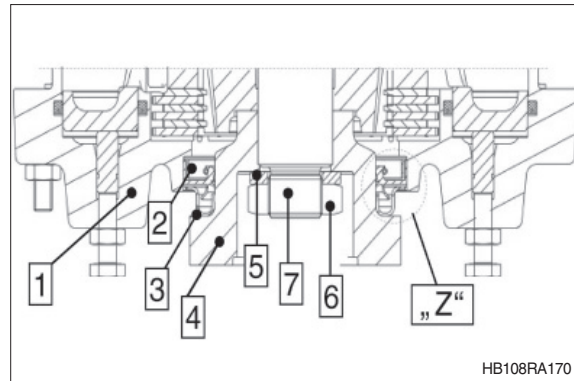

X = installation dimension $3.5^{+0.5}$ mm

- ① Insert shaft seal (2) – **observing installation dimension X (see detailed sketch, Z).**

Contact surface (outer diameter) of shaft seal:

- If rubber-coated, wet with spirit (assembly aid)
- If made of metal, apply sealing agent (loctite #574)

Grease shaft seal around the sealing and dust lip.

- ※ Pay attention to a plane installation position of the shaft seal – use the specified driver tool to ensure an exact installation position of the shaft seal.

Driver tool

5870 048 308

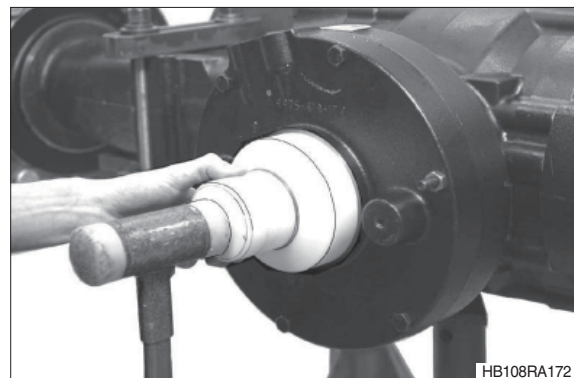

- ② Just for new parts assembly:
Mount screen sheet (3) on input flange (4) and bring to contact position.

- ※ Ensure correct installation position of screen sheet– also see sketch RA170, previous page and detailed sketch, Z.
Install screen sheet without deforming it – use suitable driver tool.

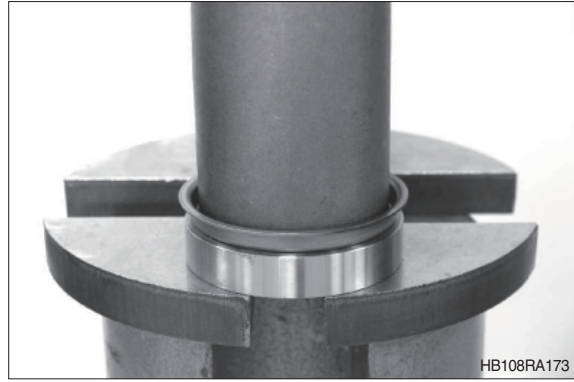

- ③ Mount preassembled input flange.

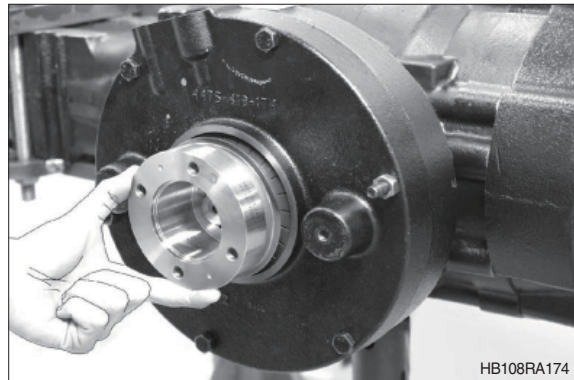

- ▲ Secure axle by using a support (arrow) – risk of accident.

- ④ Fix flange with washer (5) and hexagon nut (6).

While tightening rotate pinion in both directions several times (roller setting).

- ※ Install hexagon nut with locking compound (loctite #262).

- Tightening torque (M30×1.5) :
61.2 kgf · m (443 lbf · ft)

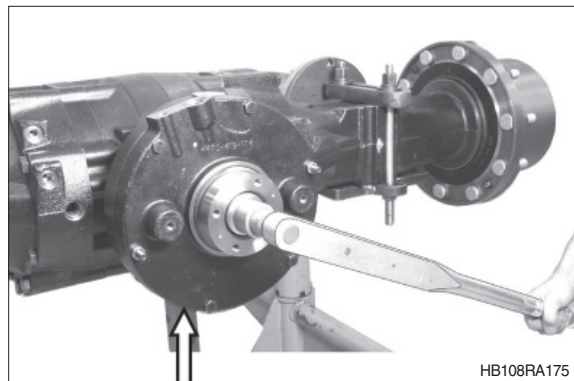

Check break-away torque of multi-disc brake:

▲ Secure axle by using a support – risk of accident.

① Fix locating piece (arrow) on input flange and check break-away torque of parking brake (do not place torque wrench on hexagon nut of input flange fixing).

※ Break-away torque of parking brake = min 102 kgf · m (738 lbf · ft).

※ In case of a proper parking brake functioning, a break-away (slipping) of < 102 kgf · m is not allowed.

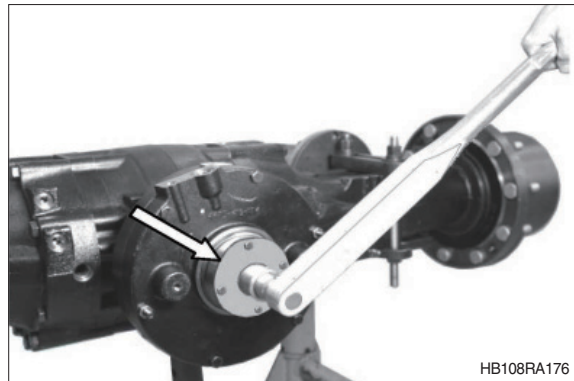

Setting of emergency breathing of multi-disc brake:

1 = Brake housing cover

2 = Hexagon screw

3 = Hexagon nut

Y = Installation dimension → 29⁺² mm

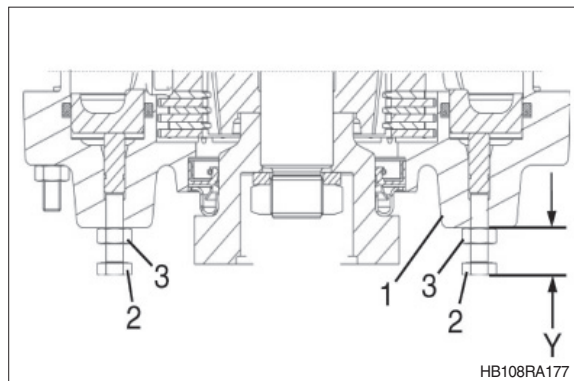

① Install both emergency breather screws, observing the installation dimension Y – see sketch.

· Tightening torque (M10 × 1) :
4.69 kgf · m (33.9 lbf · ft)

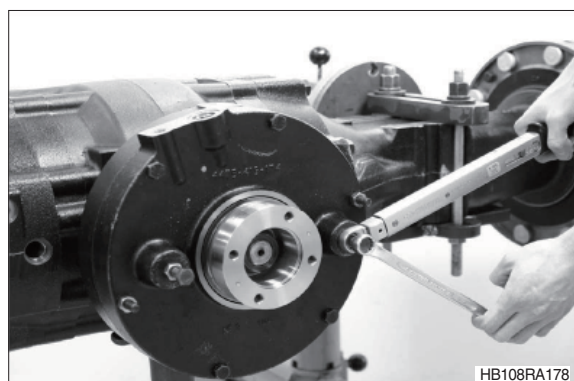

Leakage test of multi disc brake:

① Mount breather (1) and screw plug (2).

※ Install screw plug with sealing agent – (loctite #574).

· Tightening torque (1-breather) :
0.61 kgf · m (4.43 lbf · ft)

· Tightening torque (2-screw plug) :
2.55 kgf · m (18.4 lbf · ft)

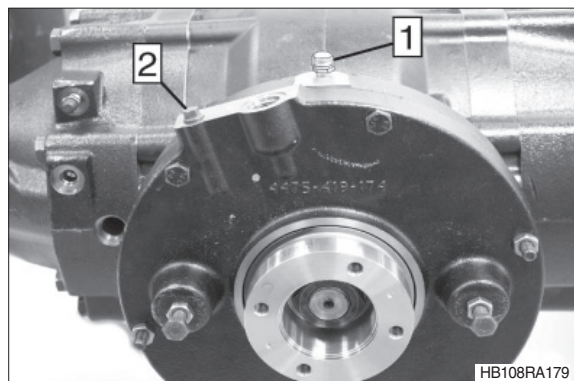

② Check:

Prior to starting the test, bleed pressure chamber and then pressurize multi-disc brake several times.

Build up test pressure $p = 13$ bar and close shut-off valve of HP pump.

- ※ A pressure drop of $\max \leq 1$ bar is permissible during a 4-minute test duration.

Test media:

Motor oils SAE-10 W corresponds

API-SE.

ATF-oils, Dexron of II D.

HP pump 5870 287 007

Reducing adapter (7/8" to G 1/4")

5870 950 159

Threaded coupling (G 1/4") 5870 950 104

- ※ Prior to putting into operation fill the axle with oil.

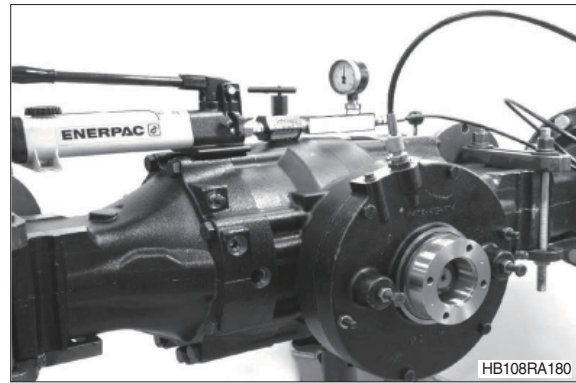

11) COMPLETION OF AXLE

- 1 = Oil drain plug
- 2 = Oil filler/level check plug
- 3 = Brake control plug
- 4 = Identification plate

- ① Fit all screw plugs with **new** O-ring and install them.

- Tightening torque (7/8" – 14 UN) :
3.06 kgf · m (22.1 lbf · ft)

Just for assembly of new parts or if disassembled:

Fix identification plate with grooved pins.

- ※ Fit screw plugs (arrow) of both output units with new O-ring and mount them.

- Tightening torque (7/8" – 14 UN) :
3.06 kgf · m (22.1 lbf · ft)

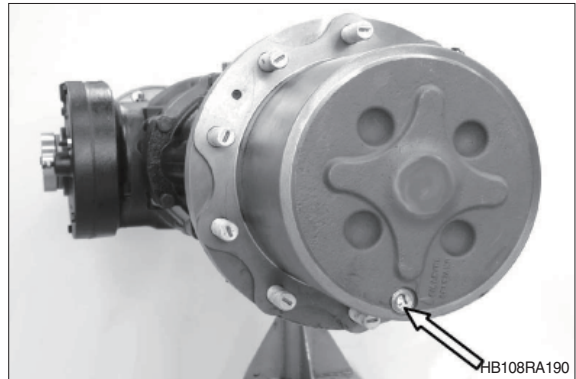
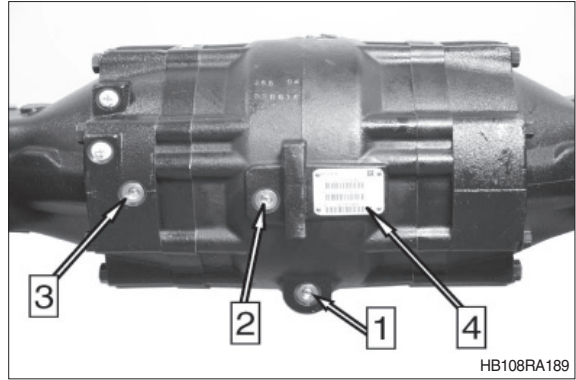

Check axle regarding leakage:

- ※ Max test pressure = 0.5 bar must not be exceeded here – risk of damage.

- ① Mount air connection into brake control hole of axle housing.
Pressurize axle with a test pressure of = 0.5 bar – and close shutoff valve.

- ※ No pressure drop is allowed during a 3-minute testing time.

Air connection	5870 286 079
Connection plug	0664 462 467
Reducing adapter (7/8" to G 1/4")	5870 950 159

- ② Remove air connection, then fit screw plug with new O-ring and install it.

- Tightening torque (7/8" – 14 UN) :
3.06 kgf · m (22.1 lbf · ft)

- ※ Prior to putting into operation fill the axle with oil.

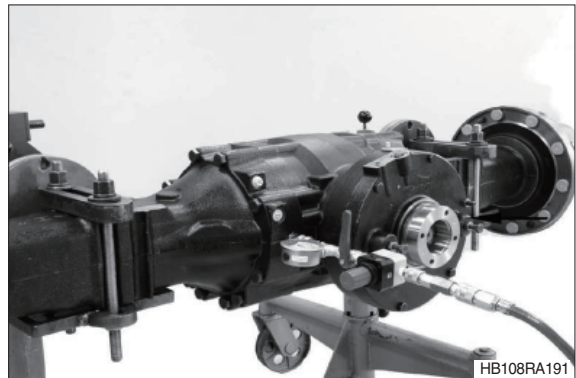

※ **EXAMPLES OF GEAR-TOOTH CONTACT PATTERNS**

- Applied the paint (or red lead) on the surface of several bevel gear teeth.
- Turn the pinion gear and check the contact pattern.

Correct pattern

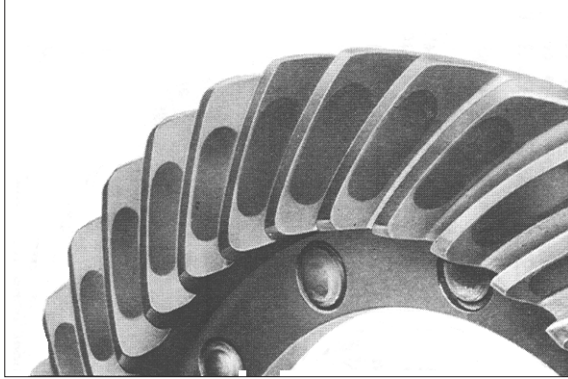

WTHAX16

Concave side

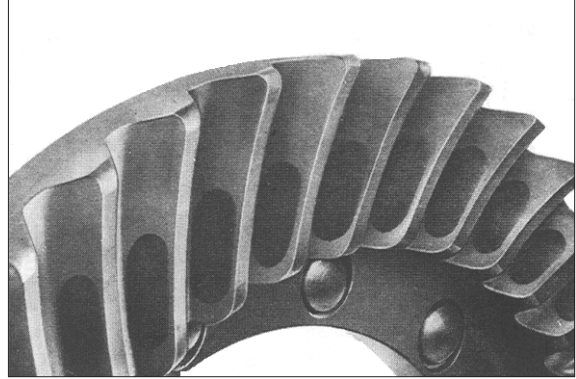

WTHAX17

Convex side

※ **ADJUSTMENT**

Incorrect pattern : high contact

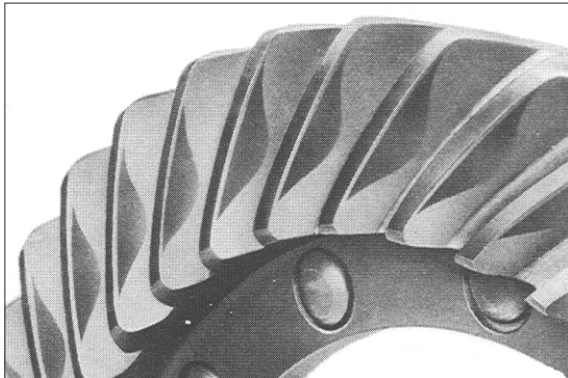

WTHAX18

Concave side

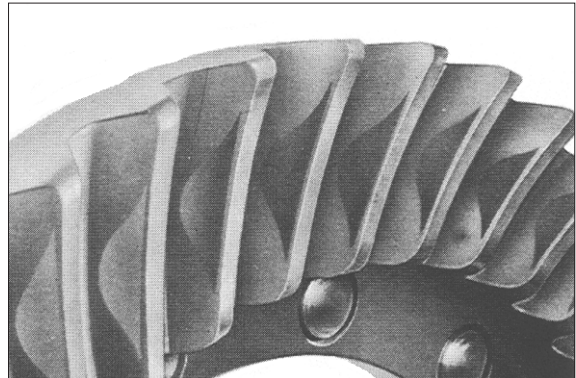

WTHAX19

Convex side

- Reduce the distance (-)

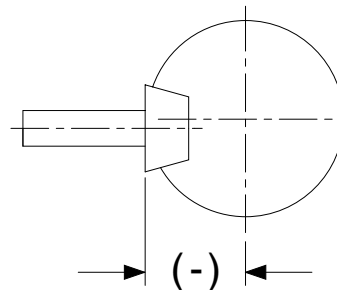

WTHAX20

Incorrect pattern, low contact

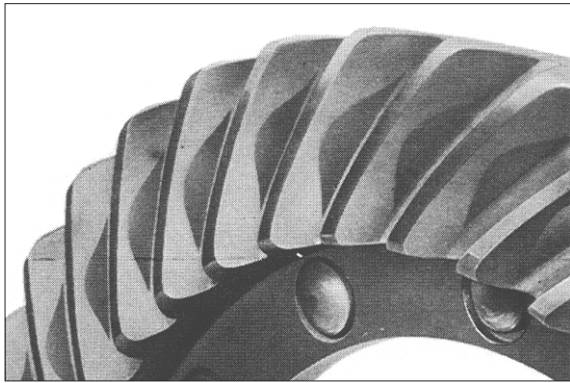

WTHAX21

Concave side

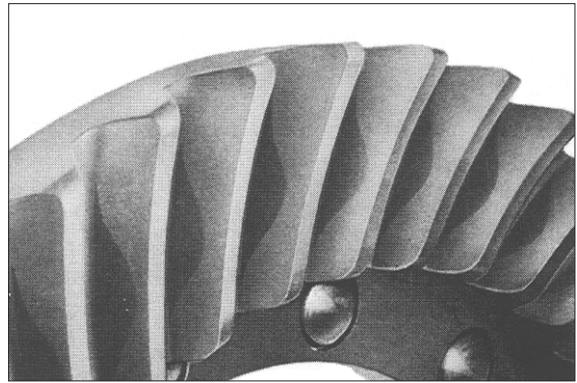

WTHAX22

Convex side

- Add the distance (+)

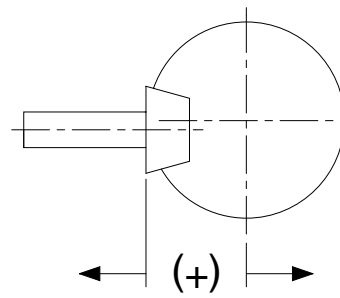

WTHAX23