

SECTION 2 ENGINE

Group 1 Structure and Function	2-1
Group 2 Engine Speed and Stall rpm	2-8

SECTION 2 ENGINE

GROUP 1 STRUCTURE AND FUNCTION

1. STRUCTURE

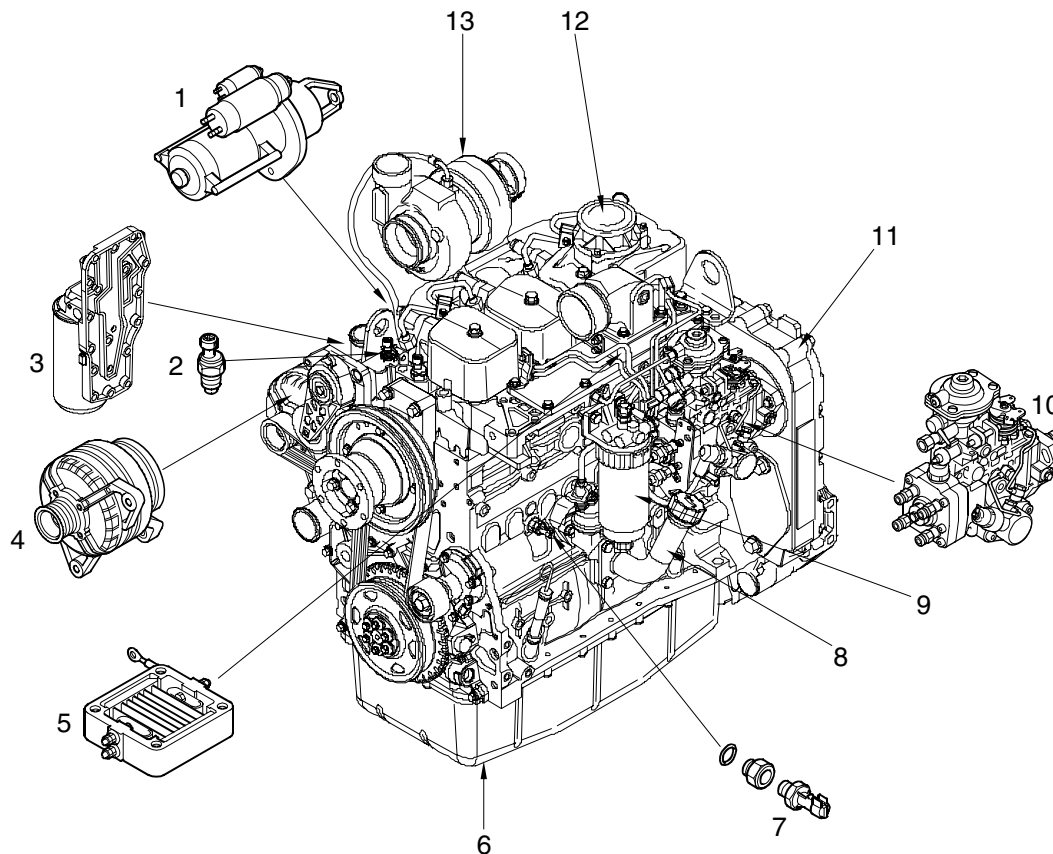

HB100EG01

- | | | | | | |
|---|------------------------------|----|---------------------|----|---------------------|
| 1 | Starter | 6 | Oil pan | 11 | Timing gear housing |
| 2 | Water temperature sensor | 7 | Oil pressure sensor | 12 | Breather valve |
| 3 | Oil filter | 8 | Oil filler | 13 | Turbocharger |
| 4 | Alternator | 9 | Fuel filter | | |
| 5 | Resistance for cold start up | 10 | Injection pump | | |

2. SYSTEM DIAGRAMS

The following drawings show the flow through the engine systems.

1) LUBRICATION

Lubrication by forced circulation is achieved through oil rotary expansion pump, placed in the front part of the basement, driven by the straight-tooth gear splined to the shaft's bar hold.

From the pan, the lubrication oil flows to the driving shaft, to the camshaft and to the valve drive.

Lubrication involves the oil cooler and the turboblower.

All these components may often vary according to the specific duty.

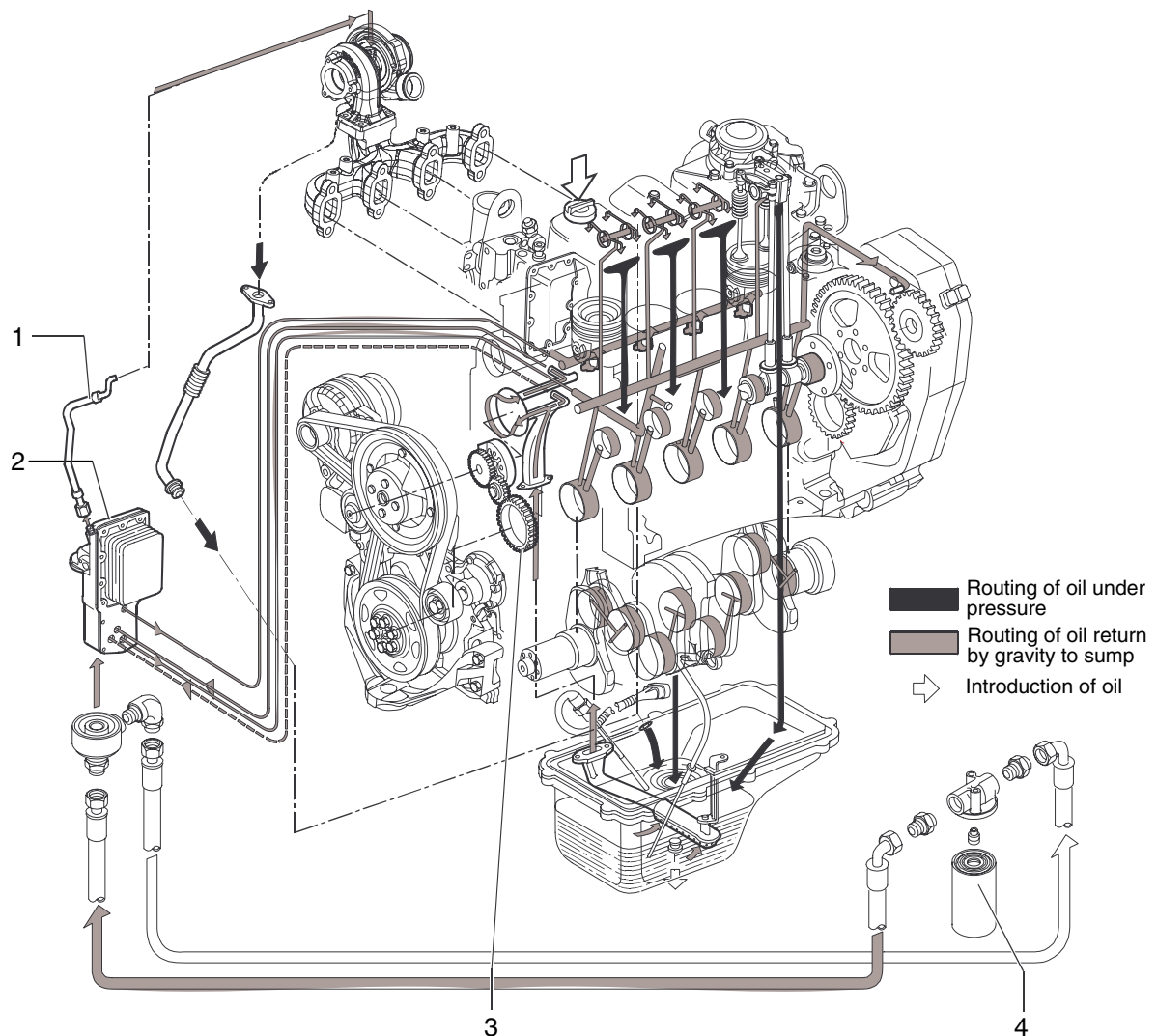

HB100EG02

- 1 Lubrication oil pipe to supercharger
- 2 Oil cooler body

- 3 Oil rotary expansion pump
- 4 Oil filter

2) OIL VAPOUR RECIRCULATING SYSTEM

On the tappet cap (3) there is a valve (1) whose duty is to condense oil vapour inducing these to fall down because of gravity, to the tappet cap underneath.

The remaining non-condensed vapours shall be properly conveyed through the breather pipe (2), by suction as an example.

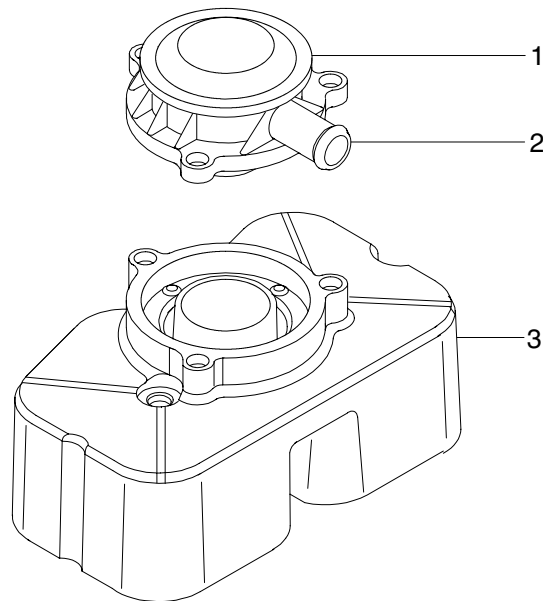

HB100EG03

- 1 Valve
- 2 Breather pipe

- 3 Tappet cap

3) COOLING SYSTEM

The engine cooling system, closed circuit forced circulation type, generally incorporates the following components :

- ① Expansion tank ; placement, shape and dimensions are subject to change according to the engine's equipment.
- ② Radiator, which has the duty to dissipate the heat subtracted to the engine by the cooling liquid. Also this component will have specific peculiarities based on the equipment developed, both for what concerns the placement and the dimensions.
- ③ Pusher fan, having the duty to increase the heat dissipating power of the radiator. This component as well will be specifically equipped based on the engine's development.
- ④ Oil cooler to cool the lubrication oil : even this component is part of the engine's specific equipment.
- ⑤ Centrifugal water pump, placed in the front part of the engine block.
- ⑥ Thermostat regulating the circulation of the cooling liquid.

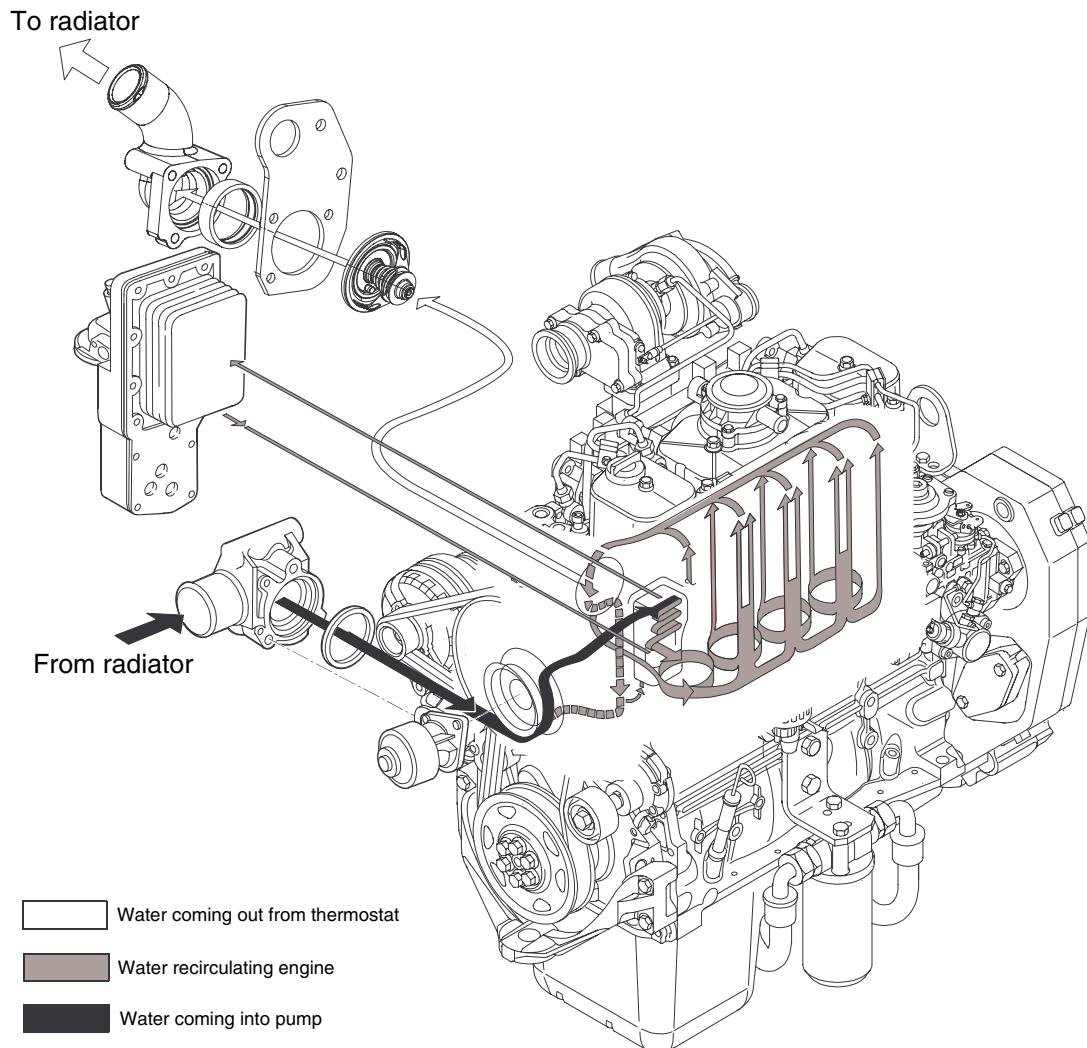

4) AIR INDUCTION BOOST DIAGRAM

(1) Boosting version engine (HB90)

The turbocharger is composed by the following main parts: one turbine, one transforming valve to regulate the boost feeding pressure , one main body and one compressor.

During engine working process, the exhaust emission flow through the body of the turbine, provoking the turbine disk wheel's rotation.

The compressor rotor, being connected by shaft to the turbine disk wheel, rotates as long as this last one rotates, compressing the sucked air through the air filter.

The air coming out of the compressor is sent via the intake manifold directly to the pistons.

The turbocharger is equipped with a transforming valve to regulate the pressure , that is located on the exhaust collector before the turbine and connected by piping to the induction collector.

It's duty is to choke the exhaust of the emissions, releasing part of them directly to the exhaust tube when the boost feeding pressure, over the compressor, reaches the prescribed bar value.

The cooling process and the lubrication of the turbocharger and of the bearings is made by the oil of the engine.

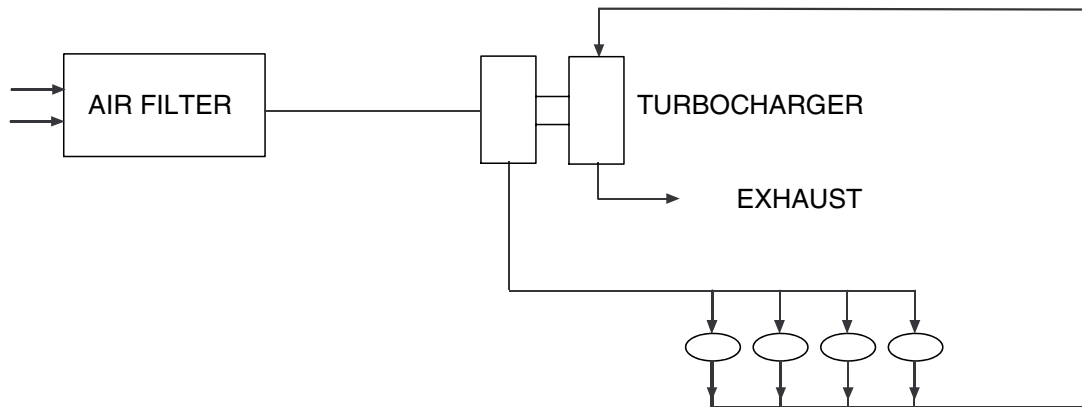

HB100EG05

(2) Inter-cooled engine version (HB100)

The turbocharger is composed by the following main parts : one turbine, one transforming valve to regulate the boost feeding pressure , one main body and one compressor.

During engine working process, the exhaust emission flow through the body of the turbine, provoking the turbine disk wheel's rotation.

The compressor rotor, being connected by shaft to the turbine disk wheel, rotates as long as this last one rotates, compressing the sucked air through the air filter.

The above mentioned air is then cooled by the radiator and flown through the piston induction collector.

The turbocharger is equipped with a transforming valve to regulate the pressure , that is located on the exhaust collector before the turbine and connected by piping to the induction collector.

It's duty is to choke the exhaust of the emissions, releasing part of them directly to the exhaust tube when the boost feeding pressure, over the compressor, reaches the prescribed bar value.

The cooling process and the lubrication of the turbocharger and of the bearings is made by the oil of the engine.

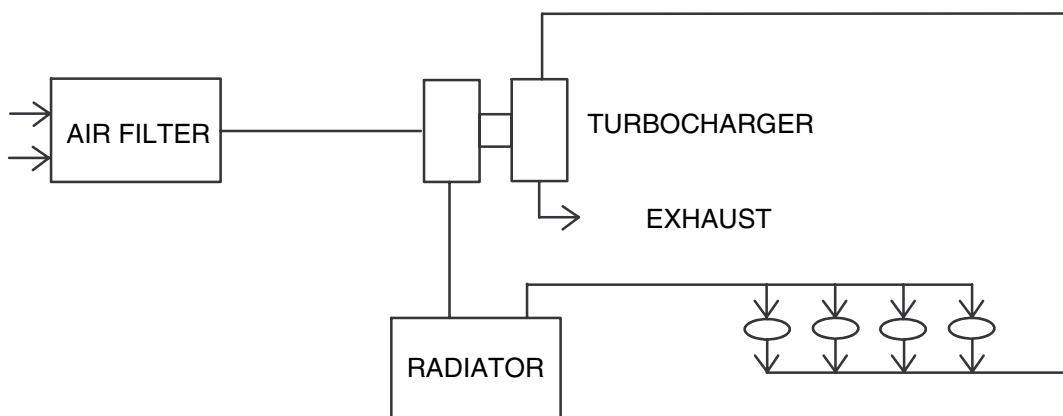

HB100EG06

5) EXHAUST GAS RE-CIRCULATION SYSTEM (EGR)

In the TIER 3 version, the profile of the exhaust cam has been modified in order to allow the partial opening of the relative valve during the aspiration phase (re-circulation of EGR exhaust gas) with the subsequent re-introduction of part of the exhaust gas into the engine cylinders.

The exhaust gases can partially be re-directed into the cylinders so as to reduce the maximum combustion temperature values responsible for the production of nitric acid (NO_x).

The exhaust gas re-circulation system (EGR), reducing the combustion temperature by means of the diminishing of the concentration of oxygen in the combustion chamber, represents therefore an efficient control system of the emission of NO_x.

The internal EGR system is not equipped with any electronically controlled elements: the system is always active.

Its configuration does not need additional elements i.e. checking valves, piping or oil coolers.

The exhaust cam (B) has another lobe apart from the major lobe (see Section A-A fig.) with respects to the configuration without EGR.

The additional lobe, during the aspiration phase in the cylinder in question, allows a brief opening of the exhaust valve generating re-circulation due to the intake of the exhaust gases caused by depression which is created in the aspiration phase inside the cylinder.

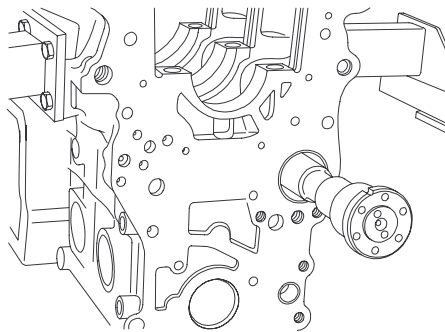

A : Aspiration valve control
B : Exhaust valve control

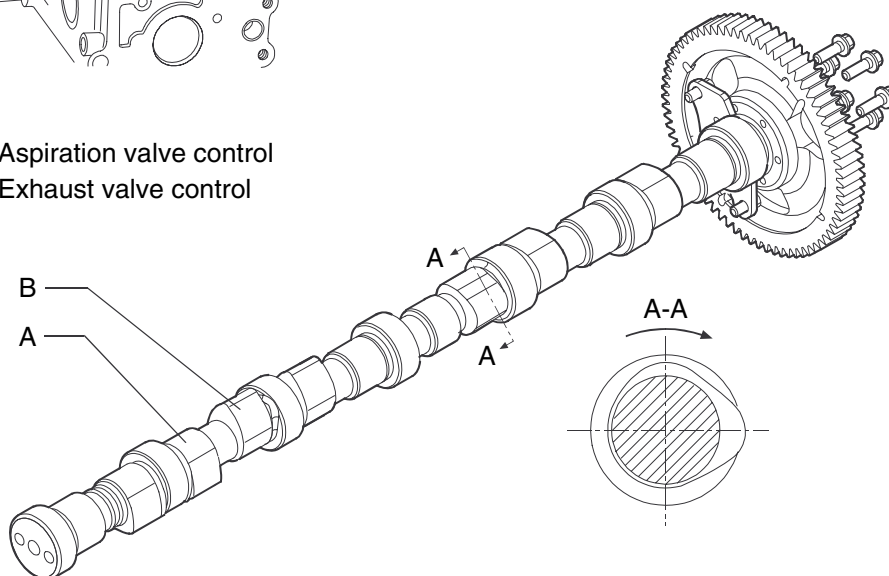

HB100EG07