

**TNV series**

---

**ELECTRONIC CONTROL  
MANUAL**

---

**YANMAR**

**FOR EPA TIER3**

**3TNV84T-Z**

**4TNV84T-Z**

**4TNV98T-Z**

**4TNV98-Z(R80-7A)**

**4TNV98-E(R55-7A,R55W-7A)**

**OPTION**

**3TNV82A-Z**

**3TNV88-Z, 3TNV88-E**

**3TNV88-Z, 4TNV88-E**

**REFERENCE ONLY**

**- MINI-EXCAVATOR(5~8TON, -7A SERIES)**

**YANMAR**

# CONTENTS

---

	Page
<b>SPECIFICATIONS</b>	
Specifications .....	1-3
Outline .....	1-13
<b>CONTROL SYSTEM</b>	
Precautions on the use of electronic control components .....	2-3
Engine control unit .....	2-3
Fuel injection pump .....	2-4
EGR valve .....	2-5
Accelerator sensor .....	2-5
Relay .....	2-6
Service tool .....	2-6
Control scheme .....	2-7
System outline .....	2-7
E-ECU .....	2-10
Electrical parts .....	2-19
Harness .....	2-24
Harness design requirements .....	2-24
Harness clamping .....	2-25
CAN bus termination .....	2-26
Control functions .....	2-27
Control software .....	2-27
General .....	2-29
Engine control - General .....	2-36
Application interface outline .....	2-43
Fuel injection pump .....	2-66
EGR valve .....	2-67
Accelerator sensor .....	2-68
Main relay .....	2-70
Rack actuator relay .....	2-70

# CONTENTS

---

Sub relay .....	2-71
Starter relay.....	2-71
Starting aid relay .....	2-73
For 400 W air heater (glow plug).....	2-73
For 500/800 W air heater .....	2-74
For 1000 W air heater .....	2-74
Coolant temperature sensors .....	2-75

Appendix Standard harness

TNV - Series service tool - Operation manual

## *Section 1*

# **SPECIFICATIONS**

---

	<b>Page</b>
Specifications .....	1-3
Outline .....	1-13

**This Page Intentionally Left Blank**

Atmospheric conditions and engine configuration affect the rated output of a TNV engine. TNV engines are tested using the methods established by the Society of Automotive Engineers (SAE) J1349 and International Organization for Standardization (ISO) 3046/1. These standards state that engine output (net power rating) should be determined under the following atmospheric conditions (called the standard conditions). If the operating environment for your application differs from these standard conditions see *Correcting Observed Power*

## SPECIFICATIONS

### DI Series

#### 3TNV82A-B

#### 3TNV82A-Z (Option Electronic Control System)

Engine model			3TNV82A-B/3TNV82A-Z													
Engine classification			CL	VM												
1	Type	—	Vertical, 4-cycle water-cooled diesel engine													
2	Combustion system	—	Direct injection (DI)													
3	No. of cylinders - Bore × Stroke	n - mm × mm	3 - 82×84													
4	Displacement	ℓ	1.331													
5	Rated engine speed	min <sup>-1</sup>					2200	2300	2400	2500	2600	2700	2800		3000	
	Output (Gross) *1	Cont. rating	kW													
		Rated output	kW					16.5	17.3	18.1	18.9	19.7	20.5	21.3		23.0
	Output (NET)	Cont. rating	kW													
Rated output		kW					16.0	16.8	17.5	18.2	19.0	19.7	20.4		21.9	
6	Maximum idling speed	min <sup>-1</sup> ±25					2375	2485	2570	2675	2780	2890	2995		3180	
7	Specific fuel consumption	g/kWh	≤245						≤252						≤258	
8	Exhaust gas temp.	°C (°F)					≤580	≤590	≤600	≤610	≤620	≤630	≤640		≤660	
9	Compression ratio	—	19.2													
10	Diesel fuel injection pressure	MPa (kgf/cm <sup>2</sup> )	19.6 <sup>+1.0</sup> <sub>0</sub> (20 <sub>0</sub> <sup>+10</sup> )													
11	Main shaft side	—	Flywheel side													
12	Rotation direction	—	Counterclockwise (Viewed from flywheel side)													
13	Governor	—	Mechanical governor (All-speed governor) / Electronic governor (All-speed governor)													
14	Aspiration	—	Natural aspiration													
15	Cooling system	—	Liquid-Cooled With Radiator													
16	Lubricating system	—	Forced lubrication with multi-stage trochoid pump													
17	Starting system	—	Electric starting													
18	Charging system	—	Alternator (12 VDC/40 A)													
19	Starting aid device	—	Super-quick Heating Glow plug													
20	Engine oil pressure	Rated speed MPa	0.34±0.05 (3.5±0.5)													
21	Oil pan capacity	Full	ℓ													
		Useful	ℓ													
22	Engine coolant capacity	ℓ	1.8 (Engine only)													
23	Cooling fan type - dia. × No. of blades	mm	Made by resin, Pusher, F Type - φ335(NF)×6													
24	Crank V-pulley dia./ Fan V-pulley dia.	mm/mm	φ120 / φ90	φ110 / φ110												

Note: This table is subject to change for performance improvement.

\*1: Gross outputs are theoretical, calculated from cooling fan formula. These are for reference only.

# SPECIFICATIONS

## 3TNV84T-Z (Electronic Control System)

Engine model			3TNV84T-Z																					
Engine classification			CL	VM																				
1	Type	—	Vertical, 4-cycle water-cooled diesel engine																					
2	Combustion system	—	Direct injection (DI)																					
3	No. of cylinders - Bore × Stroke	n - mm × mm	3 - 84×90																					
4	Displacement	ℓ	1.496																					
5	Rated engine speed	min <sup>-1</sup>																						
	Output (Gross) *1	Cont. rating	kW																					
		Rated output	kW																					
	Output (NET)	Cont. rating	kW																					
Rated output		kW																						
6	Maximum idling speed	min <sup>-1</sup> ±25																						
7	Specific fuel consumption	g/kWh																						
8	Exhaust gas temp.	°C (°F)																						
9	Compression ratio	—																						
10	Diesel fuel injection pressure	MPa (kgf/cm <sup>2</sup> )																						
11	Main shaft side	—	Flywheel side																					
12	Rotation direction	—	Counterclockwise (Viewed from flywheel side)																					
13	Governor	—	Electronic governor (All-speed governor)																					
14	Aspiration	—	Turbocharger																					
15	Cooling system	—	Liquid-Cooled With Radiator																					
16	Lubricating system	—	Forced lubrication with multi-stage trochoid pump																					
17	Starting system	—	Electric starting																					
18	Charging system	—	Alternator (12 VDC/40 A)																					
19	Starting aid device	—	Super-quick Heating Glow plug																					
20	Engine oil pressure	Rated speed MPa																						
21	Oil pan capacity	Full	ℓ																					
		Useful	ℓ																					
22	Engine coolant capacity	ℓ																						
23	Cooling fan type - dia. × No. of blades	mm																						
24	Crank V-pulley dia./ Fan V-pulley dia.	mm/mm																						

Note: This table is subject to change for performance improvement.

\*1: Gross outputs are theoretical, calculated from cooling fan formula. These are for reference only.

**3TNV88-B  
3TNV88-Z (Option Electronic Control System)**

Engine model			3TNV88-B/3TNV88-Z													
Engine classification			CL		VM											
1	Type	—	Vertical, 4-cycle water-cooled diesel engine													
2	Combustion system	—	Direct injection (DI)													
3	No. of cylinders - Bore × Stroke	n - mm × mm	3 - 88×90													
4	Displacement	ℓ	1.642													
5	Rated engine speed	min <sup>-1</sup>	1500	1800			2200	2300	2400	2500	2600	2700	2800		3000	
	Output (Gross) *1	Cont. rating	kW	12.7	15.4											
		Rated output	kW	13.9	16.9			20.3	21.3	22.2	23.2	24.2	25.1	26.0		28.1
	Output (NET)	Cont. rating	kW	12.3	14.8											
Rated output		kW	13.5	16.3			19.9	20.7	21.6	22.6	23.5	24.3	25.2		27.1	
6	Maximum idling speed	min <sup>-1</sup> ±25	1600	1895			2400	2510	2590	2690	2810	2920	2995		3210	
7	Specific fuel consumption	g/kWh	≤245					≤252					≤258			
8	Exhaust gas temp.	°C (°F)	≤540	≤560			≤590	≤600	≤610	≤620	≤630	≤640	≤650		≤670	
9	Compression ratio	—	19.1													
10	Diesel fuel injection pressure	MPa (kgf/cm <sup>2</sup> )	19.6 <sup>+1.0</sup> <sub>0</sub> (200 <sup>+10</sup> <sub>0</sub> )													
11	Main shaft side	—	Flywheel side													
12	Rotation direction	—	Counterclockwise (Viewed from flywheel side)													
13	Governor	—	Mechanical governor (All-speed governor) / Electronic governor (All-speed governor)													
14	Aspiration	—	Natural aspiration													
15	Cooling system	—	Liquid-Cooled With Radiator													
16	Lubricating system	—	Forced lubrication with multi-stage trochoid pump													
17	Starting system	—	Electric starting													
18	Charging system	—	Alternator (12 VDC/40 A)													
19	Starting aid device	—	Super-quick Heating Glow plug													
20	Engine oil pressure	Rated speed	MPa	0.34±0.05 (3.5±0.5)												
21	Oil pan	Full	ℓ	6.7												
	capacity	Useful	ℓ	2.8												
22	Engine coolant capacity	ℓ	2.0 (Engine only)													
23	Cooling fan type - dia. × No. of blades	mm	Made by resin, Pusher, F Type - φ335(NF)×6													
24	Crank V-pulley dia./ Fan V-pulley dia.	mm/mm	φ120 / φ90		φ110 / φ110											

Note: This table is subject to change for performance improvement.

\*1: Gross outputs are theoretical, calculated from cooling fan formula. These are for reference only.

# SPECIFICATIONS

## 3TNV88-U

## 3TNV88-E (Option Electronic Control System)

Engine model			3TNV88-U/3TNV88-E												
Engine classification			CL	VM											
1	Type	—	Vertical, 4-cycle water-cooled diesel engine												
2	Combustion system	—	Direct injection (DI)												
3	No. of cylinders - Bore × Stroke	n - mm × mm	3 - 88×90												
4	Displacement	l	1.642												
5	Rated engine speed	min <sup>-1</sup>				2100	2200	2300	2400	2500	2600	2700	2800		3000
			Output (Gross) *1	Cont. rating	kW										
	Rated output	kW					17.7	18.6	19.4	20.3	21.2	22.1	23.0	23.9	
	Output (NET)	Cont. rating	kW												
Rated output		kW				17.3	18.1	18.9	19.7	20.5	21.3	22.2	23.0		24.6
6	Maximum idling speed	min <sup>-1</sup> ±25				2290	2400	2510	2590	2690	2810	2920	2995		3210
7	Specific fuel consumption	g/kWh	≤245						≤252				≤258		
8	Exhaust gas temp.	°C (°F)				≤570	≤580	≤590	≤600	≤610	≤620	≤630	≤640		≤660
9	Compression ratio	—	19.1												
10	Diesel fuel injection pressure	MPa (kgf/cm <sup>2</sup> )	19.6 <sup>+1.0</sup> <sub>0</sub> (200 <sup>+10</sup> <sub>0</sub> )												
11	Main shaft side	—	Flywheel side												
12	Rotation direction	—	Counterclockwise (Viewed from flywheel side)												
13	Governor	—	Mechanical governor (All-speed governor) / Electronic governor (All-speed governor)												
14	Aspiration	—	Natural aspiration												
15	Cooling system	—	Liquid-Cooled With Radiator												
16	Lubricating system	—	Forced lubrication with multi-stage trochoid pump												
17	Starting system	—	Electric starting												
18	Charging system	—	Alternator (12 VDC/40 A)												
19	Starting aid device	—	Super-quick Heating Glow plug												
20	Engine oil pressure	Rated speed	MPa	0.34±0.05 (3.5±0.5)											
21	Oil pan capacity	Full	l	6.7											
		Useful	l	2.8											
22	Engine coolant capacity	l	2.0 (Engine only)												
23	Cooling fan type - dia. × No. of blades	mm	Made by resin, Pusher, F Type - φ335(NF)×6												
24	Crank V-pulley dia./ Fan V-pulley dia.	mm/mm	φ120 / φ90	φ110 / φ110											

Note: This table is subject to change for performance improvement.

\*1: Gross outputs are theoretical, calculated from cooling fan formula. These are for reference only.



# SPECIFICATIONS

## 4TNV88-B

## 4TNV88-Z (Option Electronic Control System)

Engine model			4TNV88-B/4TNV88-Z													
Engine classification			CL		VM											
1	Type	—	Vertical, 4-cycle water-cooled diesel engine													
2	Combustion system	—	Direct injection (DI)													
3	No. of cylinders - Bore × Stroke	n - mm × mm	4 - 88×90													
4	Displacement	ℓ	2.189													
5	Rated engine speed	min <sup>-1</sup>	1500	1800	2000	2100	2200	2300	2400	2500	2600	2700	2800		3000	
	Output (Gross) *1	Cont. rating	kW	16.9	20.5											
		Rated output	kW	18.5	22.5	24.6	25.9	27.1	28.4	29.7	31.0	32.3	33.6	35.0		36.9
	Output (NET)	Cont. rating	kW	16.4	19.6											
Rated output		kW	18.0	21.6	24.1	25.3	26.5	27.7	28.8	30.1	31.3	32.5	33.7		35.4	
6	Maximum idling speed	min <sup>-1</sup> ±25	1600	1895	2180	2290	2400	2510	2590	2700	2810	2920	2995		3210	
7	Specific fuel consumption	g/kWh	≤245							≤252						
8	Exhaust gas temp.	°C (°F)	≤520	≤540	≤560	≤570	≤580	≤590	≤600	≤610	≤620	≤630	≤640		≤660	
9	Compression ratio	—	19.1													
10	Diesel fuel injection pressure	MPa (kgf/cm <sup>2</sup> )	19.6 <sup>+1.0</sup> <sub>0</sub> (200 <sup>+10</sup> <sub>0</sub> )													
11	Main shaft side	—	Flywheel side													
12	Rotation direction	—	Counterclockwise (Viewed from flywheel side)													
13	Governor	—	Mechanical governor (All-speed governor) / Electronic governor (All-speed governor)													
14	Aspiration	—	Natural aspiration													
15	Cooling system	—	Liquid-Cooled With Radiator													
16	Lubricating system	—	Forced lubrication with multi-stage trochoid pump													
17	Starting system	—	Electric starting													
18	Charging system	—	Alternator (12 VDC/40 A)													
19	Starting aid device	—	Super-quick Heating Glow plug													
20	Engine oil pressure	Rated speed	MPa	0.34±0.05 (3.5±0.5)												
21	Oil pan capacity	Full	ℓ	7.4												
		Useful	ℓ	3.4												
22	Engine coolant capacity	ℓ	2.7 (Engine only)													
23	Cooling fan type - dia. × No. of blades	mm	Made by resin, Pusher, F Type - φ370(EF)×6													
24	Crank V-pulley dia./ Fan V-pulley dia.	mm/mm	φ120 / φ90				φ110 / φ110									

Note: This table is subject to change for performance improvement.

\*1: Gross outputs are theoretical, calculated from cooling fan formula. These are for reference only.

**4TNV88-U**  
**4TNV88-E (Option Electronic Control System)**

Engine model			4TNV88-U/4TNV88-E													
Engine classification			CL	VM												
1	Type	—	Vertical, 4-cycle water-cooled diesel engine													
2	Combustion system	—	Direct injection (DI)													
3	No. of cylinders - Bore × Stroke	n - mm × mm	4 - 88×90													
4	Displacement	ℓ	2.189													
5	Rated engine speed	min <sup>-1</sup>											2700	2800		
	Output (Gross) *1	Cont. rating	kW													
		Rated output	kW											30.7	31.9	
	Output (NET)	Cont. rating	kW													
Rated output		kW											29.6	30.7		
6	Maximum idling speed	min <sup>-1</sup> ±25											2920	2995		
7	Specific fuel consumption	g/kWh	≤245						≤252				≤258			
8	Exhaust gas temp.	°C (°F)											≤630	≤640		
9	Compression ratio	—	19.1													
10	Diesel fuel injection pressure	MPa (kgf/cm <sup>2</sup> )	19.6 <sup>+1.0</sup> <sub>0</sub> (200 <sup>+10</sup> <sub>0</sub> )													
11	Main shaft side	—	Flywheel side													
12	Rotation direction	—	Counterclockwise (Viewed from flywheel side)													
13	Governor	—	Mechanical governor (All-speed governor) / Electronic governor (All-speed governor)													
14	Aspiration	—	Natural aspiration													
15	Cooling system	—	Liquid-Cooled With Radiator													
16	Lubricating system	—	Forced lubrication with multi-stage trochoid pump													
17	Starting system	—	Electric starting													
18	Charging system	—	Alternator (12 VDC/40 A)													
19	Starting aid device	—	Super-quick Heating Glow plug													
20	Engine oil pressure	Rated speed MPa	0.34±0.05 (3.5±0.5)													
21	Oil pan capacity	Full	7.4													
		Useful	3.4													
22	Engine coolant capacity	ℓ	2.7 (Engine only)													
23	Cooling fan type - dia. × No. of blades	mm	Made by resin, Pusher, F Type - φ370(EF)×6													
24	Crank V-pulley dia./ Fan V-pulley dia.	mm/mm	φ120 / φ90			φ110 / φ110										

Note: This table is subject to change for performance improvement.

\*1: Gross outputs are theoretical, calculated from cooling fan formula. These are for reference only.

# SPECIFICATIONS

## 4TNV98-Z(R80-7A)

Engine model			4TNV98-Z								
Engine classification			CL		VM						
1	Type	—	Vertical, 4-cycle water-cooled diesel engine								
2	Combustion system	—	Direct injection (DI)								
3	No. of cylinders - Bore × Stroke	n - mm × mm	4 - 98×110								
4	Displacement	ℓ	3.318								
5	Rated engine speed	min <sup>-1</sup>	1500	1800	2000	2100	2200	2300	2400	2500	
	Output (Gross) *1	Cont. rating	kW	31.2	37.2						
		Rated output	kW	34.9	41.6	42.5	44.4	46.3	48.2	50.2	52.1
	Output (NET)	Cont. rating	kW	30.9	36.8						
Rated output		kW	34.6	41.2	41.9	43.8	45.6	47.4	49.3	51.1	
6	Maximum idling speed	min <sup>-1</sup> ±25	1600	1895	2180	2290	2400	2510	2590	2700	
7	Specific fuel consumption	g/kWh	≤224						≤231		
8	Exhaust gas temp.	°C (°F)	≤580	≤600	≤600	≤610	≤620	≤630	≤640	≤650	
9	Compression ratio	—	18.5								
10	Diesel fuel injection pressure	MPa (kgf/cm <sup>2</sup> )	21.6 <sup>+1.0</sup> <sub>0</sub> (220 <sup>+10</sup> <sub>0</sub> )								
11	Main shaft side	—	Flywheel side								
12	Rotation direction	—	Counterclockwise (Viewed from flywheel side)								
13	Governor	—	Electronic governor (All-speed governor)								
14	Aspiration	—	Natural aspiration								
15	Cooling system	—	Liquid-Cooled With Radiator								
16	Lubricating system	—	Forced lubrication with multi-stage trochoid pump								
17	Starting system	—	Electric starting								
18	Charging system	—	Alternator (12 VDC/40 A)								
19	Starting aid device	—	Air heater (12 VDC/500 W)								
20	Engine oil pressure	Rated speed	MPa	0.34±0.05 (3.5±0.5)							
21	Oil pan capacity	Full	ℓ	10.2							
		Useful	ℓ	4.5							
22	Engine coolant capacity	ℓ	4.2 (Engine only)								
23	Cooling fan type - dia. × No. of blades	mm	Made by resin, Pusher, F Type - φ410(A)×6								
24	Crank V-pulley dia./ Fan V-pulley dia.	mm/mm	φ130 / φ130								

Note: This table is subject to change for performance improvement.

\*1: Gross outputs are theoretical, calculated from cooling fan formula. These are for reference only.

**4TNV98-E(R55-7A,R55W-7A)**

Engine model			4TNV98-E							
Engine classification			CL	VM						
1	Type	—	Vertical, 4-cycle water-cooled diesel engine							
2	Combustion system	—	Direct injection (DI)							
3	No. of cylinders - Bore × Stroke	n - mm × mm	4 - 98×110							
4	Displacement	ℓ	3.318							
5	Rated engine speed	min <sup>-1</sup>			2100	2200	2300	2400	2500	
	Output (Gross) *1	Cont. rating	kW							
		Rated output	kW			37.4	39.0	40.5	42.4	44.0
	Output (NET)	Cont. rating	kW							
Rated output		kW			36.8	38.2	39.7	41.6	43.0	
6	Maximum idling speed	min <sup>-1</sup> ±25			2290	2400	2510	2590	2700	
7	Specific fuel consumption	g/kWh	≤224					≤231		
8	Exhaust gas temp.	°C (°F)			≤610	≤620	≤630	≤640	≤650	
9	Compression ratio	—	18.5							
10	Diesel fuel injection pressure	MPa (kgf/cm <sup>2</sup> )	21.6 <sup>+1.0</sup> <sub>0</sub> (220 <sup>+10</sup> <sub>0</sub> )							
11	Main shaft side	—	Flywheel side							
12	Rotation direction	—	Counterclockwise (Viewed from flywheel side)							
13	Governor	—	Electronic governor (All-speed governor)							
14	Aspiration	—	Natural aspiration							
15	Cooling system	—	Liquid-Cooled With Radiator							
16	Lubricating system	—	Forced lubrication with multi-stage trochoid pump							
17	Starting system	—	Electric starting							
18	Charging system	—	Alternator (12 VDC/40 A)							
19	Starting aid device	—	Air heater (12 VDC/500 W)							
20	Engine oil pressure	Rated speed MPa	0.34±0.05 (3.5±0.5)							
21	Oil pan capacity	Full	ℓ							
		Useful	ℓ							
22	Engine coolant capacity	ℓ	4.2 (Engine only)							
23	Cooling fan type - dia. × No. of blades	mm	Made by resin, Pusher, F Type - φ410(A!)×6							
24	Crank V-pulley dia./ Fan V-pulley dia.	mm/mm	φ130 / φ130							

Note: This table is subject to change for performance improvement.

\*1: Gross outputs are theoretical, calculated from cooling fan formula. These are for reference only.

# SPECIFICATIONS

## 4TNV98T-Z

Engine model			4TNV98T-Z						
Engine classification			CL	VM					
1	Type	—	Vertical, 4-cycle water-cooled diesel engine						
2	Combustion system	—	Direct injection (DI)						
3	No. of cylinders - Bore × Stroke	n - mm × mm	4 - 98×110						
4	Displacement	ℓ	3.318						
5	Rated engine speed	min <sup>-1</sup>							
	Output (Gross) *1	Cont. rating	kW						
		Rated output	kW						
	Output (NET)	Cont. rating	kW						
Rated output		kW							
6	Maximum idling speed	min <sup>-1</sup> ±25							
7	Specific fuel consumption	g/kWh							
8	Exhaust gas temp.	°C (°F)							
9	Compression ratio	—							
10	Diesel fuel injection pressure	MPa (kgf/cm <sup>2</sup> )							
11	Main shaft side	—	Flywheel side						
12	Rotation direction	—	Counterclockwise (Viewed from flywheel side)						
13	Governor	—	Electronic governor (All-speed governor)						
14	Aspiration	—	Turbocharger						
15	Cooling system	—	Liquid-Cooled With Radiator						
16	Lubricating system	—	Forced lubrication with multi-stage trochoid pump						
17	Starting system	—	Electric starting						
18	Charging system	—	Alternator (12 VDC/40 A)						
19	Starting aid device	—	Air heater (12 VDC/500 W)						
20	Engine oil pressure	Rated speed MPa							
21	Oil pan capacity	Full	10.2						
		Useful	4.5						
22	Engine coolant capacity	ℓ	4.2 (Engine only)						
23	Cooling fan type - dia. × No. of blades	mm							
24	Crank V-pulley dia./ Fan V-pulley dia.	mm/mm							

Note: This table is subject to change for performance improvement.

\*1: Gross outputs are theoretical, calculated from cooling fan formula. These are for reference only.

**OUTLINE**

**DI Series**

**3TNV82A-B**

**3TNV82A-Z (Option Electronic Control System)**

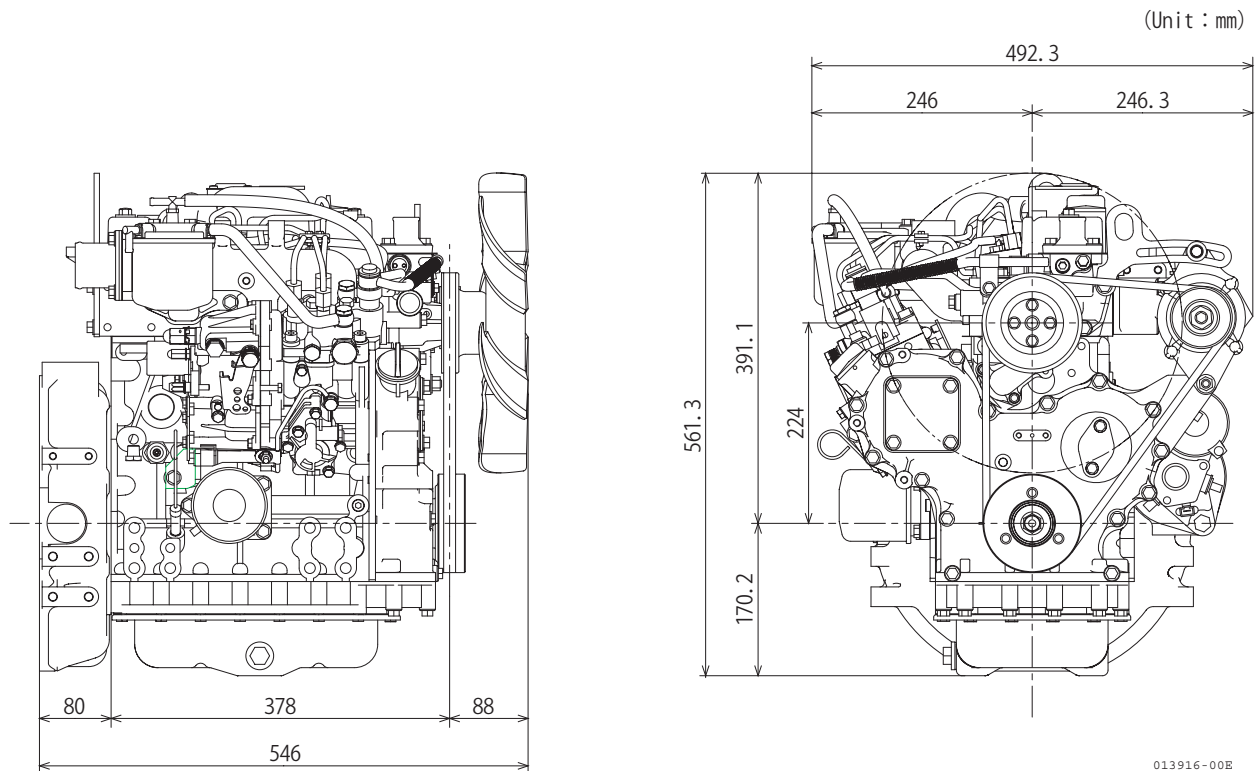

# SPECIFICATIONS

## 3TNV88-U/3TNV88-B 3TNV88-E/3TNV88-Z (Option Electronic Control System)

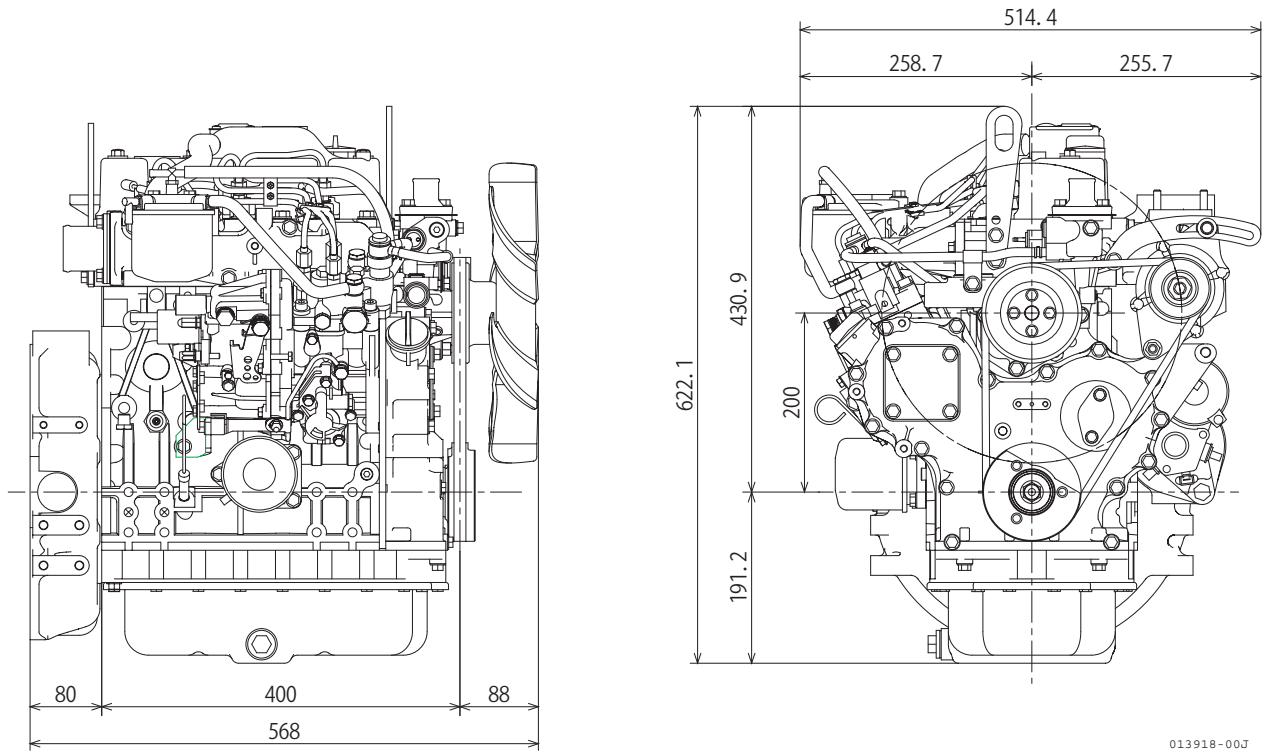

## 3TNV84T-Z

**It is developing.**

**4TNV88-U/4TNV88-B  
4TNV88-E/4TNV88-Z (Option Electronic Control System)**

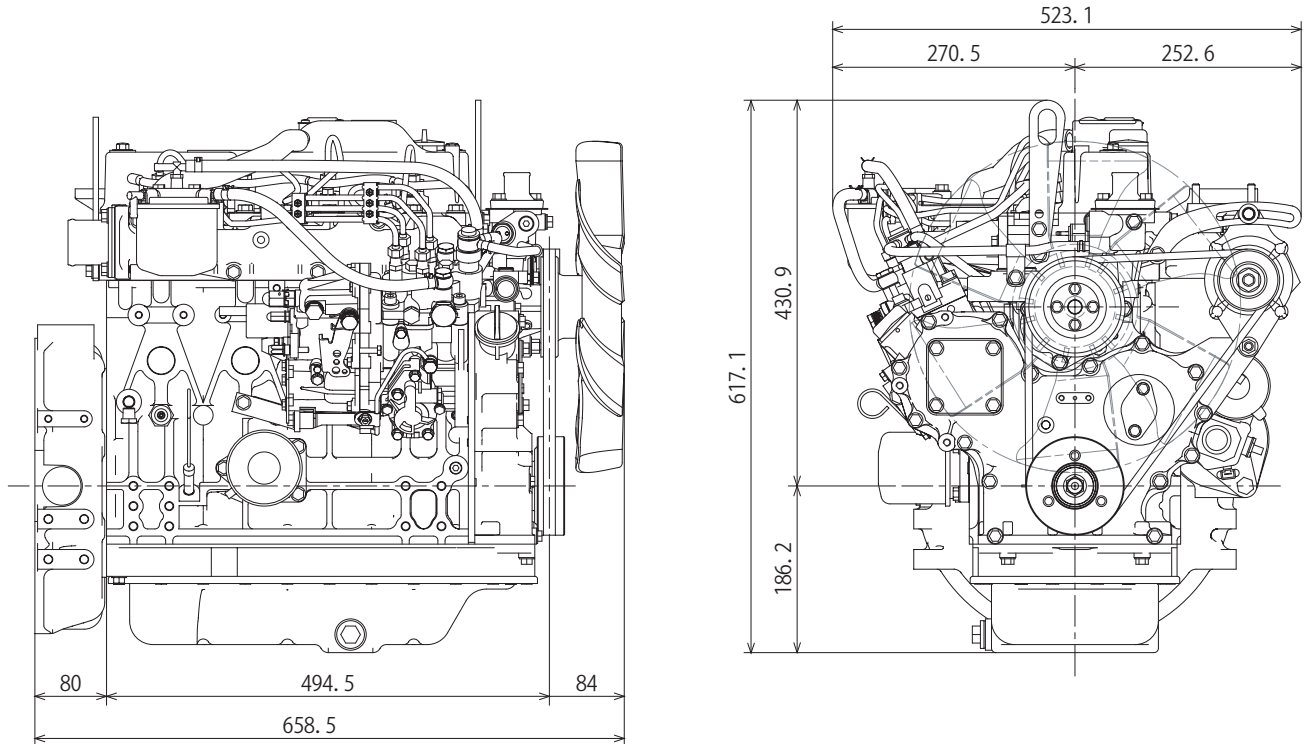

013919-00J

**4TNV84T-Z**

**It is developing.**

# SPECIFICATIONS

## 4TNV98-E/4TNV98-Z

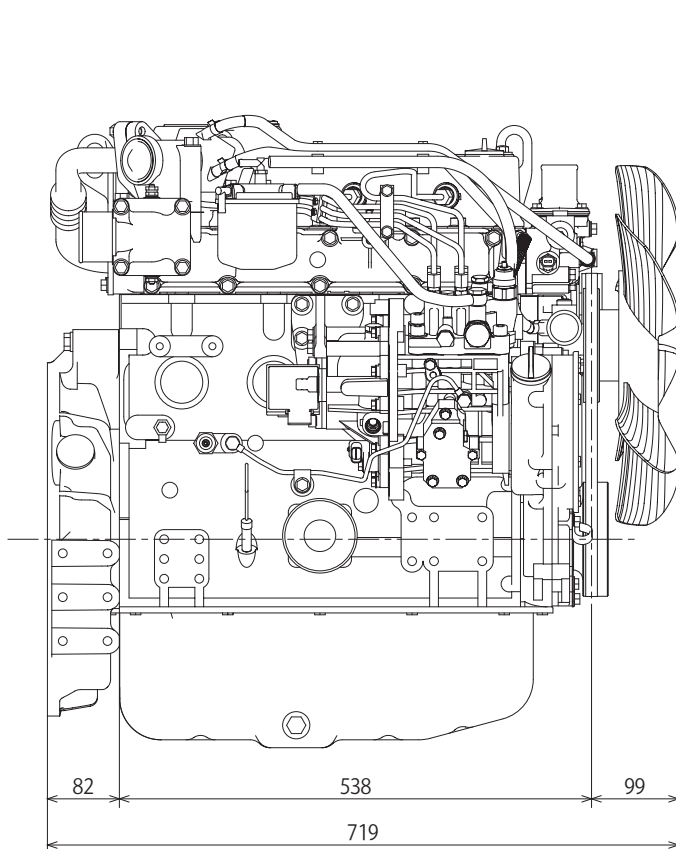

013917-00J

## 4TNV98T-Z (For Tier3)

**It is developing.**

## Section 2

# CONTROL SYSTEM

---

	Page
Precautions on the use of electronic control components .....	2-3
Engine control unit.....	2-3
Fuel injection pump .....	2-4
EGR valve .....	2-5
Accelerator sensor.....	2-5
Relay .....	2-6
Service tool.....	2-6
Control scheme .....	2-7
System outline.....	2-7
E-ECU .....	2-10
Electrical parts .....	2-19
Harness .....	2-24
Harness design requirements.....	2-24
Harness clamping.....	2-25
CAN bus termination .....	2-26
Control functions .....	2-27
Control software .....	2-27
General.....	2-29
Engine control - General.....	2-36
Application interface outline.....	2-43
Fuel injection pump .....	2-66
EGR valve .....	2-67
Accelerator sensor .....	2-68
Main relay.....	2-70
Rack actuator relay .....	2-70
Sub relay .....	2-71
Starter relay.....	2-71
Starting aid relay .....	2-73
For 400 W air heater (glow plug).....	2-73
For 500/800 W air heater.....	2-74
For 1000 W air heater.....	2-74
Coolant temperature sensors .....	2-75

**This Page Intentionally Left Blank**

This chapter describes a Yanmar second-generation electronic governor (herein referred to as the "Gen2 Eco-governor") that conforms to the third EPA regulation by controlling Exhaust Gas Recirculation (EGR). The Gen2 Eco-governor is standard equipped on NV3 and supercharged engines. It is also available as an option for other engines. Contact Yanmar for details.

The engine electronic control unit (E-ECU) controls the speed and power of the engine by adjusting the rack position of the fuel injection pump depending on the signal from the accelerator sensor.

The opening of the EGR valve is adjusted depending on the engine speed and load factor so as to ensure conformance to exhaust emission standards.

The Gen2 Eco-governor provides control to the engine depending on the throttle position, coolant temperature, external-switch positions, signals through CAN or other parameters and is superior to a mechanical governor in versatility.

This manual provides overall description of the Gen2 Eco-governor. Optional setting of the E-ECU must be done by Yanmar. Contact Yanmar for details.

## PRECAUTIONS ON THE USE OF ELECTRONIC CONTROL COMPONENTS

### Engine control unit

Read **Control scheme (P.7)** carefully before designing a engine control system comprising the engine electronic control unit (E-ECU) and other control components in order to ensure correct application of the components.

Observe precautions in **Harness (P.24)** when designing wire harnesses.

Be sure to perform installation assessment as specified by Yanmar to ensure applicability of the E-ECU and other control components to the intended machine.

At the first power-up, the E-ECU is initialized and cannot be used to start the engine. See **Check for initialization of the E-ECU (P.14)** for details.

Be sure to use the E-ECU in conjunction with engines, the type and serial number of which are specified by Yanmar. Failure to do so will result in no assurance that the engine develops the intended performance.

Never use the E-ECU if the failure lamp is flashing. Doing so will result in no assurance that the engine develops the intended performance and may cause serious damage to the engine.

Place the failure lamp and other indicators so that they are readily visible to personnel.

When replacing the E-ECU, be sure to contact Yanmar in advance. The fuel injection quantity data must be transferred from the old E-ECU to the new unit. See **Control software (P.27)** for details. If the fuel injection quantity data is not transferred to the new E-ECU, the engine is not assured to develop the intended performance.

Updating the fuel injection quantity data in the E-ECU requires a Yanmar genuine service tool. See the manual for the service tool for the maintenance procedure.

The customer must not perform tasks that are specified to be done by Yanmar, including replacement of the E-ECU, rewriting or modification of data in the E-ECU and removal of sensors or actuators. Such tasks done by the customer may be deemed an infringement of exhaust emission control laws and regulations. Yanmar assumes no responsibility for any loss or damage caused by incompliance with instructions or suggestions in this chapter.

## CONTROL SYSTEM

### Fuel injection pump

Be sure to perform installation assessment as specified by Yanmar to ensure applicability of the fuel injection pump to the intended machine.

The fuel injection pump should in particular be arranged so that the ambient temperature of the rack position sensor amplifier and the solenoid CSD does not exceed 80°C.

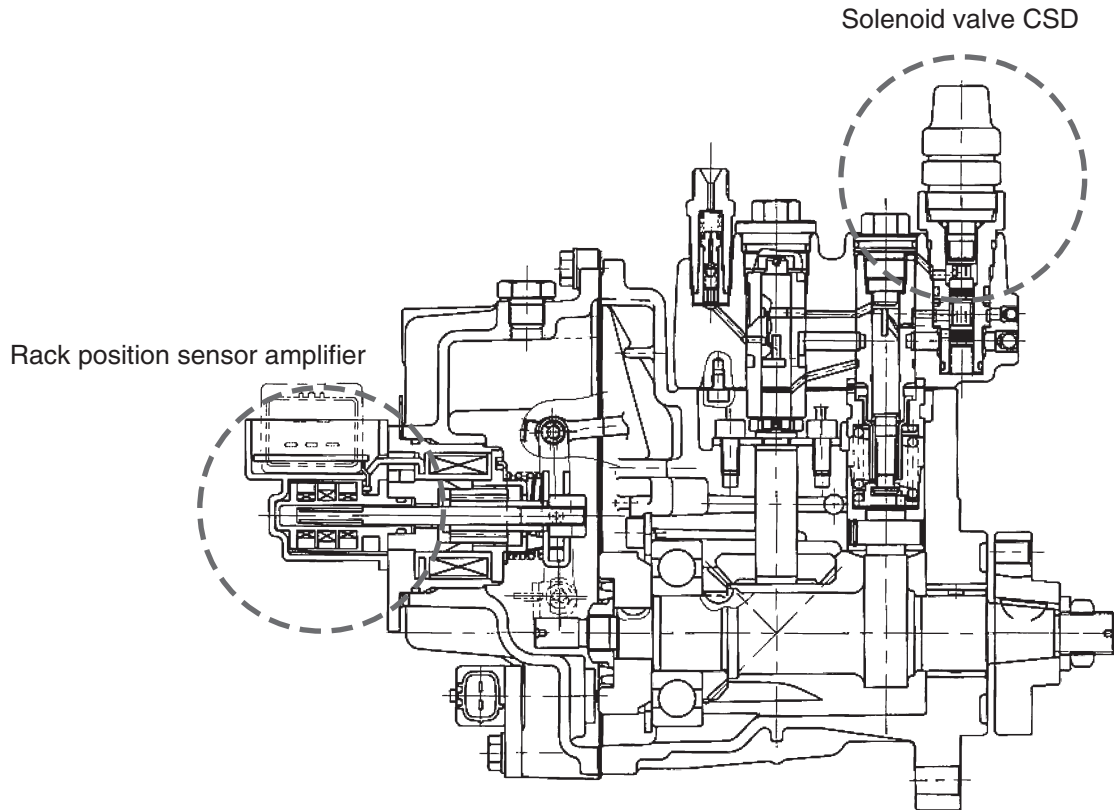

**Figure 2-1 Type MP fuel injection pump of the Eco-governor**

Supply power to the rack position sensor via terminal AVB (E43) of the E-ECU.

The fuel injection pump requires its specific injection quantity data. When replacing the fuel injection pump, be sure to use the attached fuel injection quantity data to update the memory in the E-ECU. Failure to do so will result in no assurance that the engine develops the intended performance.

Updating the fuel injection quantity data in the E-ECU requires a Yanmar genuine service tool. See the manual for the service tool for the maintenance procedure.

## EGR valve

Be sure to perform installation assessment as specified by Yanmar to ensure applicability of the EGR valve to the intended machine.

Do not expose the EGR valve motor to an ambient temperature exceeding 80°C.

## Accelerator sensor

Connect the accelerator sensor according to the recommended connection diagram. Make sure the accelerator sensor and the E-ECU have a common reference potential (GND potential) as shown in example [A] of **Figure 2-2**. If the E-ECU is connected to a machine controller as shown in example [B] or [C], the difference between the E-ECU and the machine controller in reference potential ( $V_1 \neq V_2$ ) may cause excess voltage to be applied to the APS input of the E-ECU or excess current to flow through GND-A.

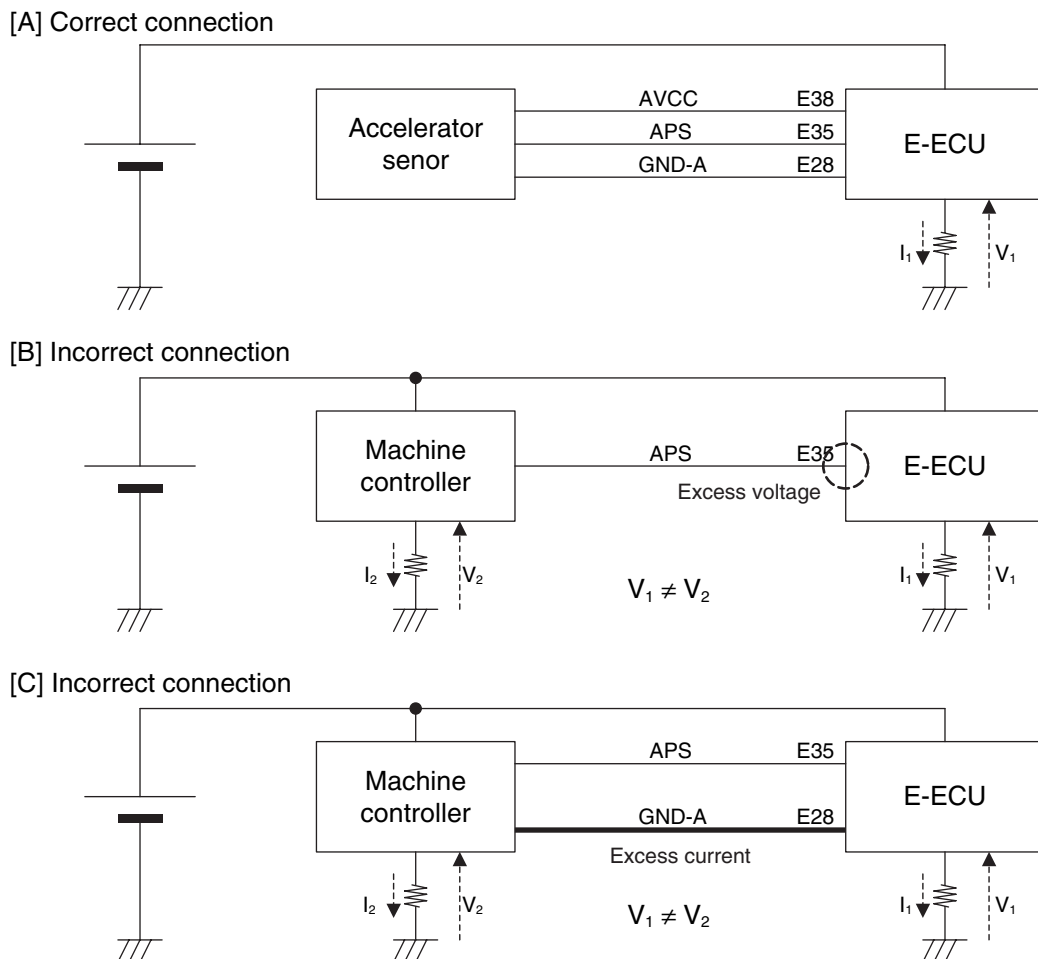

**Figure 2-2 Accelerator sensor connection examples**

Read **Accelerator sensor (P.68)** carefully before utilizing a Yanmar genuine accelerator sensor in order to ensure correct use of the sensor.

Be sure to perform installation assessment as specified by Yanmar to ensure applicability of the accelerator sensor to the intended machine.

# CONTROL SYSTEM

---

## Relay

Be sure to perform installation assessment as specified by Yanmar to ensure applicability of the relay to the intended machine.

## Service tool

Install the connector shown in **Figure 2-3** at a convenient position on the intended machine in order to permit connection of the Yanmar genuine service tool.

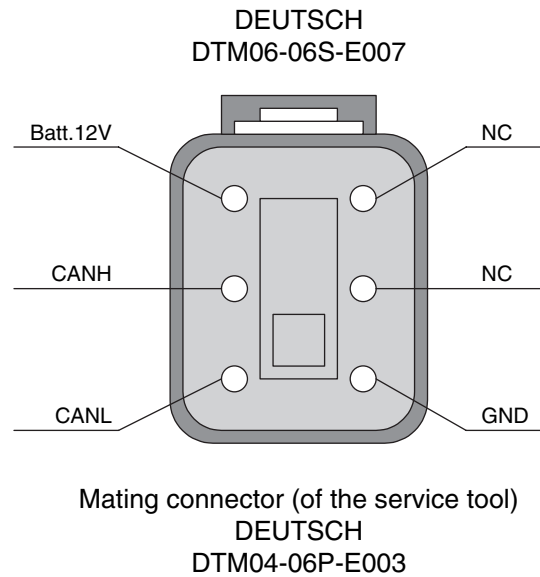
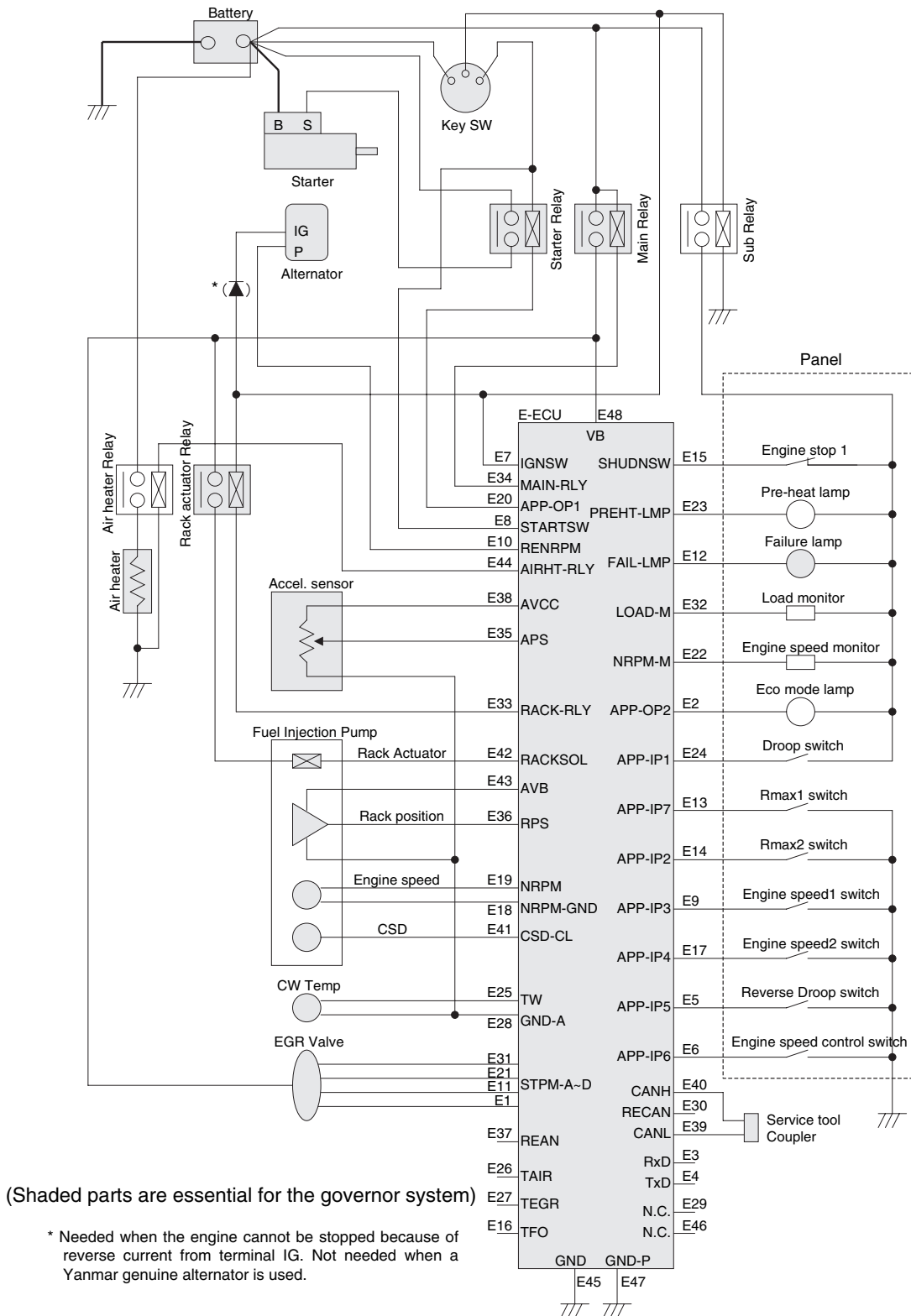

**Figure 2-3 Service tool connector**

# CONTROL SCHEME

## System outline

The electrical connection diagram of the Gen2 Eco-governor is shown in **Figure 2-4** below.



**Figure 2-4** Electrical connection diagram of the Eco-governor system

# CONTROL SYSTEM

---

The following describes each of the components shown in Figure 2-4.

## [Main relay]

- Allows avoiding a long electrical wiring between the battery and E-ECU terminal VB.
- Allows self-holding of the E-ECU power and logging of engine events including faults and running time when the key switch is off.
- Prevents reverse current from being applied to the E-ECU or rack actuator in case of reverse connection of battery terminals.

## [Rack actuator relay]

- Cuts off the power to the actuator to stop the engine when the key switch is turned off, regardless whether or not the main relay causes self-holding of the E-ECU power.
- Cuts off the power to the actuator to stop the engine when the sub microcomputer detects overspeed, regardless of the status of the main microcomputer.

## [Sub relay]

- Prevents the capacity of the main relay circuit from exceeding 7.0 A. (The design capacity of the fuse in the main relay circuit must be 10 A or less because the nominal cross sectional area of the cable applicable to the rack actuator connector is 0.75 mm<sup>2</sup>).
- Prevents reverse current from being applied to the I/O terminals of the E-ECU panel in case of reverse connection of battery terminals.

## [Air heater relay]

- Enables the E-ECU to provide ON-glow control, simultaneous energization or after heating to the starting aid (air heater or glow plug).

## [Starter relay]

- Prevents the starter motor from starting until the rack self-diagnostics on power-on is completed (for approx. 0.5 second).
- Prevents failure caused by starter overrun.
- Limits the starter-on time to prevent failure caused by starter overcranking (optional feature).
- Synchronizes the starter operation with the crutch pedal switch position or the like (optional feature).

## [Alternator terminal P]

- Provides backup rotation pulse signals to be used in cases where the rotation sensor fails to produce engine rotation pulse output.
- Using backup rotation pulse signals degrades the accuracy of the engine speed measurements because the signals do not reflect belt slip. The engine speed is therefore limited as long as the backup signals are used.

## [Failure lamp]

- Alerts the operator to a fault occurring in the Eco-governor system or a start of energization of the E-ECU.

## [Service tool coupler]

- Enables getting control data from the E-ECU or making a detailed diagnostics of the Eco-governor system.
- Enables maintenance of data, programs, parameters etc. in the E-ECU.

## [Accelerator sensor]

- The Eco-governor has no governor lever unlike mechanical governors and uses voltage signals from the accelerator sensor to set a target speed.
- If the engine speed is changed stepwise to constant values as in the case of generator engines, a panel switch can be used to change the engine speed and the accelerator sensor is not needed.
- Using CAN communication permits a target engine speed to be specified from the E-ECU of the intended machine. In such a case, the accelerator sensor is not needed.

## [Coolant temperature sensor]

- Detects the coolant temperature to control CSD or EGR for cold start. Using the Yanmar genuine sensor eliminates the possibility of using other devices in parallel.

## [Panel switches and lamps]

- Enables options of the E-ECU to be used. If optional features are not needed, the corresponding switches or lamps may be kept disconnected.

## [About the starting aid]

- The circuit shown in **Figure 2-4** allows the E-ECU to control the starting aid relay and provide ON-glow, simultaneous energization or after-heating. The preheat lamp can be turned on when the starting aid is energized during the ON-glow process.
- Even when the Eco-governor is used, preheating can be turned on or off with the key switch. In such a case, the electrical circuit of the starting aid is the same as in the case where a mechanical governor is used. See 6 "Cold-starting aid" for details.
- When the Eco-governor is used, after-heating as well as preheating can be turned on or off with the key switch. In this case, the key switch with a "preheat" position and the air heater relay are required in the starting aid circuit. See 6 "Cold-starting aid" for details.

## [About a diode to be inserted in alternator terminal IG]

- The engine may be impossible to stop because the current generated by the alternator flows reversely from alternator terminal IG to the harness circuit.
- To avoid such a trouble, you should separate alternator terminal IG from the rack actuator excitation circuit or insert a diode (marked with an asterisk in **Figure 2-4**) into alternator terminal IG in order to prevent reverse current from the terminal.

# CONTROL SYSTEM

## E-ECU

### Outline

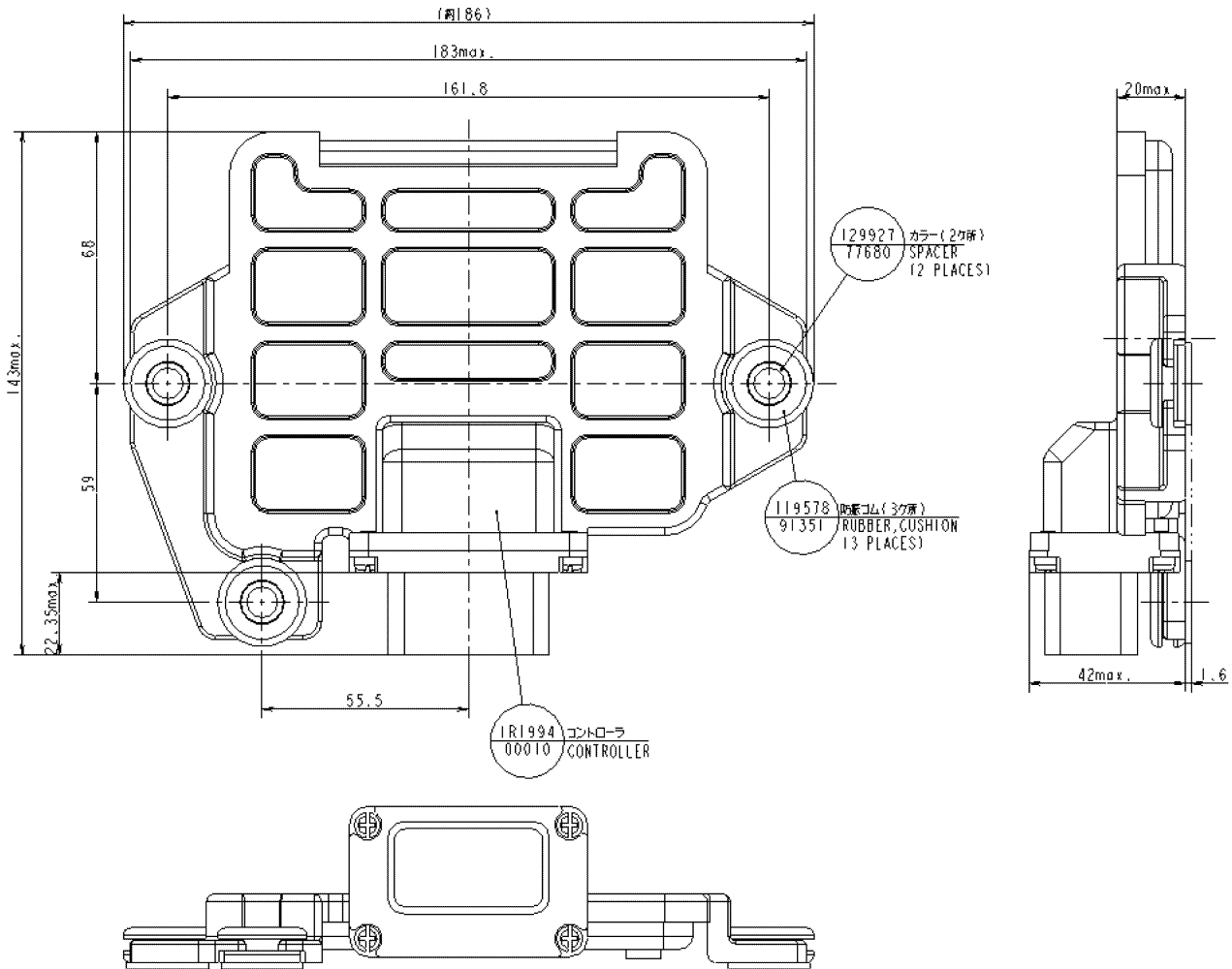

**Figure 2-5 E-ECU outline**

Use the specified grommets (119578-91351) and collars (129927-77680) for the E-ECU. Vibrations of the engine or machine could cause malfunction of the E-ECU.

**Figure 2-6** shown the connector pin numbers of the E-ECU. Note that the connection diagram in **Figure 2-4** uses the pin numbers with a prefix of "E" as circuit symbols.



Circuit symbols: Pin number with prefix "E"

**Figure 2-6 E-ECU connector pin Nos.**

**Operating conditions**

Table 2-1 shows the operating conditions of the E-ECU.

**Table 2-1 Operating conditions of the E-ECU**

Item		Requirement
Rated voltage		12 Vdc
Operating ambient temperature		-30°C ~ 80°C
Storage ambient temperature		-40°C ~ 110°C
Operating voltage range		10.0 – 16.0 Vdc
Minimum operating voltage		6.0 Vdc Min.
Vibration	Severity level	To be installed on a place of 45 or lower in severity level
	The acceleration, speed and displacement of the E-ECU mount must conform to the requirements shown to the right in an overall range of 5 - 1000 Hz.	Acceleration:70.4 m/s <sup>2</sup> (rms) Max.
		Speed:44.6 mm/s (rms) Max. Displacement:0.283 mm (rms) Max. 0.800 mm (p.p) Max.
Waterproofness (of connector)		<ul style="list-style-type: none"> <li>• JIS D0203 S2 compliant</li> <li>• The E-ECU must not be installed with its connector facing upward.</li> </ul>

**Precautions:**

- Install the E-ECU in a location that is not subject to steam or high-pressure water for cleaning.
- Install the E-ECU in a location that is well ventilated and not subject to direct sunlight.
- Install the E-ECU so that the connector faces downward. Failure to do so may trap water in the connector, resulting in corrosion of connector pins.
- Do not plug or unplug the connector for at least 6 seconds after the E-ECU is turned on or off.
- Do not touch connector pins with bare hands. Doing so may corrode or statically charge connector pins, resulting in damage to electronic components in the E-ECU.
- Do not force a measuring or testing probe into the female coupler of the connector. Doing so may cause contact failure of connector pins, resulting in malfunction of the E-ECU.
- Ensure no water is trapped inside the coupler when plugging or unplugging the connector. Water inside the coupler may corrode connector pins, resulting in malfunction of the E-ECU.
- Avoid plugging/unplugging the connector more than ten times. Repeated plugging/unplugging may cause contact failure of connector pins, resulting in malfunction of the E-ECU.
- Do not use the E-ECU that has suffered drop impact.
- When the machine is used in areas where a cryoprotectant/salt is distributed or near the seashore, the aluminum case of the E-ECU may corrode, resulting in malfunction of the E-ECU. Use a cover to protect the E-ECU against salt intrusion.

## CONTROL SYSTEM

---

### Current consumption

The current consumption for engine control is shown in **Table 2-2**. A current of at least 4 or 5 A should always be stored in the battery for engine control. (We recommend a stored current of 5 A for frequent cold starts or 4A for otherwise).

**Table 2-2 Current consumption for engine control**

	Design value	Measured value	
		rms	Max.
E-ECU GND	5.40 [A]	3.72 [A]	6.56 [A]
CSD	1.90 [A]	0.90 [A]	1.02 [A]
Air heater relay excitation	0.20 [A]	-	-
Panel switch	0.10 [A]	-	-
Total	7.60 [A]	4.61 [A]	7.58 [A]

Note: Power supply voltage is assumed to be 14.8V.

### Minimum operating voltage

The minimum operating voltage of the E-ECU is 6.0 Vdc. Decreasing the E-ECU power supply voltage to less than the above causes the E-ECU to reset.

When the battery voltage decreases to less than 6.0 V repeatedly at compression steps during cranking in cold start conditions, for example, the engine may not be able to start. To avoid such a trouble, check the battery and E-ECU power supply for correct voltage.

**Figure 2-7** provides the transition of the E-ECU power supply voltage at engine start.

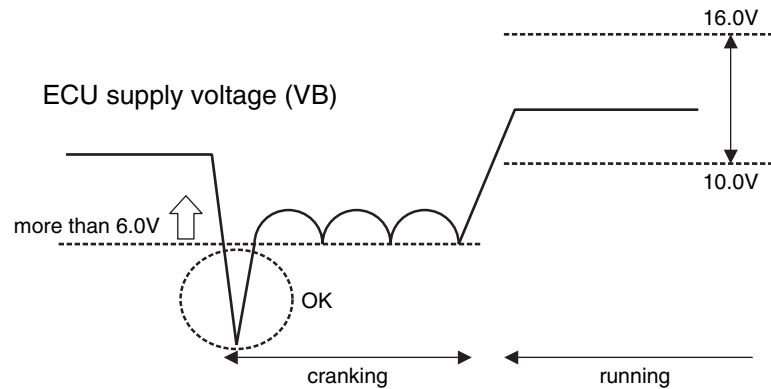

**Figure 2-7** Transition of E-ECU power supply voltage at engine start

### Minimum detectable speed

The E-ECU cannot detect speeds less than  $100 \text{ min}^{-1}$ .

### Number of start/stop cycles and duration of energization

The E-ECU saves engine logs in the internal EEPROM and updates them every time the power turns off if the power self-holding feature (described later) is enabled, or at regular intervals if the power self-holding feature is disabled. The design service life of the E-ECU is therefore dependent on the maximum number of EEPROM write cycles.

The service life of EEPROM is limited to the order of 105 key-on operations if the power self-holding feature is enabled, or 104 key-on duration hours if the power self-holding feature is disabled.

EEPROM is a nonvolatile storage; data stored in EEPROM is not lost if the E-ECU power turns off.

### Safety features

The E-ECU has the following safety features:

- Two independent watchdog timers monitor the control software, and reset the microcomputer if detecting a problem.
  - (1) The WDTs are supplied by the power supply IC to monitor the programs of the main and sub microcomputers.
  - (2) The sub microcomputer monitors the program of the main microcomputer.
- If the sub microcomputer detects an overspeed condition of the engine, it turns off the rack actuator relay to cut off the engine. (On overspeed condition occurs when the engine speed reaches High Idling Speed plus  $600 \text{ min}^{-1}$  by default).
- The power supply terminal (VB) of the E-ECU has a zener diode for protection against dump surge. As the rack actuator and the rack position sensor must be protected by the zener diode, the power lines for these components should be branched at a point as close to terminal VB as practicable.

# CONTROL SYSTEM

---

## About battery reverse connection

- Battery reverse connection will cause damage to the E-ECU and the rack position sensor.
- To protect the E-ECU and the rack position sensor against inadvertent reverse connection, main and sub relays fitted with a reverse connection prevention diode (198461-52950) should be arranged as indicated on the standard connection diagrams (E3-29927-0030/0040).

## Check for initialization of the E-ECU

The E-ECU is factory set so that the internal EEPROM is reset at the first power-up of the E-ECU. At the first power-up, check for correct initialization of the E-ECU (EEPROM) as follows:

At the first power-up: When the failure lamp illuminates, initialization is complete. The engine cannot be started in succession to the initialization process. To enable starting the engine, turn off the power to the E-ECU; then turn on the power again.

If the failure lamp remains off, the harness or the E-ECU is probably out of order. See "Troubleshooting chart" for details.

At the second and later power-up: When the failure lamp illuminates for two seconds and then goes out, the E-ECU works normally. If the failure lamp remains off or flashes, the harness or the E-ECU is probably out of order. See "Troubleshooting chart" for details.

I/O layout

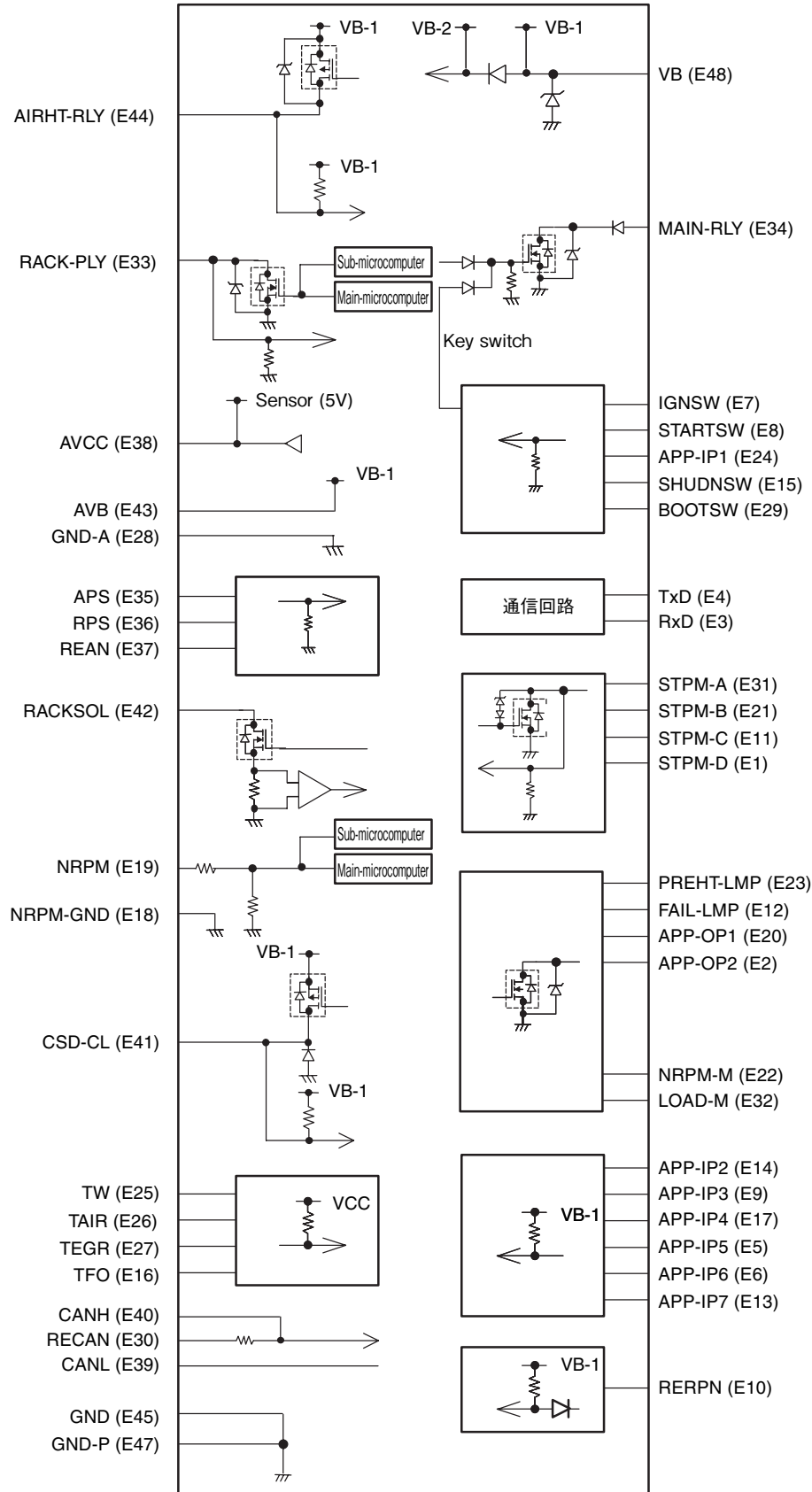

Figure 2-8 E-ECU I/O layout

# CONTROL SYSTEM

## I/O description

**Table 2-3 E-ECU I/O description**

I/O	Type	Pin function/name	Symbol	No.	Description
Input	Analog	Accelerator position sensor	APS	E35	Recommended load: Potentiometer (5 kΩ) Range: 0 – 5V Accuracy: 512±13 (@2.5V) Input resistance: 200 kΩ
		Rack position sensor	RPS	E36	Specified load: Rack position sensor Range: 0 – 5V Accuracy after adjustment: 716±2 (@3.5 V/25 – 30°C) Input resistance: 100 kΩ
		Coolant temperature	TW	E25	Specified load: Thermistor (119254-44910) Range: -30 – +120°C Accuracy after adjustment: ±3°C (@0°C/5.88 kΩ) Output resistance: 1.5 kΩ
		Intake air temperature(reserve)	TAIR	E26	Specified load: Thermistor (124399-12750) Range: -30 – +120°C Accuracy: ±5°C (@20°C/2.45 kΩ) Output resistance: 1.5 kΩ
		EGR temperature(reserve)	TEGR	E27	Specified load: Thermistor (not defined) Range: 0 – 200°C Accuracy: ±5°C (@100°C/1.10 kΩ) Output resistance: 1.5 kΩ
		FO Temperature (reserve)	TFO	E16	Specified load: Thermistor (119254-44910) Range: -30 – +120°C Accuracy: ±5°C (@20°C/2.45 kΩ) Output resistance: 1.5 kΩ
		Reserved analog(reserve)	REAN	E37	Recommended load: Atmosphere pressure sensor (not defined) Range: 0 – 5 V Accuracy: 512±13 (@2.5 V) Input resistance: 100 kΩ
	Contact	Engine start recognition	STARTSW	E8	Circuit: High side Pull-down resistance: 1.2 kΩ (10 mA@12 V)
		Engine emergency stop	SHUDNSW	E15	Circuit: High side, interrupt port Pull-down resistance: 1.2 kΩ (10 mA@12 V)
		Key switch	IGNSW	E7	Circuit: High side, interrupt port Pull-down resistance: 1.2 kΩ (10 mA@12 V)
		Application input 1	APP-IP1	E24	Circuit: High side Pull-down resistance: 1.2 kΩ (10 mA@12 V)
		Application input 2	APP-IP2	E14	Circuit: Low side, interrupt port Pull-up resistance: 1.2 kΩ (10 mA@12 V)
		Application input 3	APP-IP3	E9	Circuit: Low side Pull-up resistance: 1.2 kΩ (10 mA@12 V)
		Application input 4	APP-IP4	E17	Circuit: Low side Pull-up resistance: 1.2 kΩ (10 mA@12 V)
		Application input 5	APP-IP5	E5	Circuit: Low side Pull-up resistance: 1.2 kΩ (10 mA@12 V)
		Application input 6	APP-IP6	E6	Circuit: Low side Pull-up resistance: 1.2 kΩ (10 mA@12 V)
		Application input 7	APP-IP7	E13	Circuit: Low side Pull-up resistance: 1.2 kΩ (10 mA@12 V)
	Pulse	Speed input (-)	NRPM-GND	E18	Specified load: Electromagnetic pickup (158557-61720) Range: 10 – 400Hz
		Speed input (+)	NRPM	E19	
Backup speed sensor		RENRPMP	E10	Circuit: Low side, interrupt port Pull-up resistance: 1.2 kΩ (10 mA@12 V)	

**Table 2-3 E-ECU I/O description**

I/O	Type	Pin function/name	Symbol	No.	Description
Output	Contact	Rack actuator	RACKSOL	E42	Circuit: High side, PWM port Output: 6.0 A Max. (@12 V)
		Main relay	MAIN-RLY	E34	Circuit: High side Output: 200 mA Max. (@12 V)
		Rack actuator relay	RACK-RLY	E33	Circuit: High side Output: 200 mA Max. (@12 V)
		Air heater relay	AIRHT-RLY	E44	Circuit: Low side Output: 12 A Max. (@12 V)
		CSD solenoid coil	CSD-CL	E41	Circuit: Low side, PWM port Output: 2.41 A Max. (@12 V)
		Failure lamp	FAIL-LMP	E12	Circuit: High side Output: 300 mA Max. (@12 V) Lamp load: 12 V/3.4 W Max. Rush current: 12V/3 A-10ms Max.
		Preheat lamp	PREHT-LMP	E23	Circuit: High side Output: 300 mA Max. (@12 V) Lamp load: 12 V/3.4 W Max. Rush current: 12V/3 A-10ms Max.
		Application output 1	APP-OP1	E20	Circuit: High side, PWM port Output: 300 mA Max. (@12 V) Lamp load: 12 V/3.4 W Max. Rush current: 12V/3 A-10ms Max. Relay load: 40 Ω Min., 200 mH Max.
		Application output 2	APP-OP2	E2	Circuit: High side, PWM port Output: 300 mA Max. (@12 V) Lamp load: 12 V/3.4 W Max. Rush current: 12V/3 A-10ms Max. Relay load: 40 Ω Min., 200 mH Max.
	Pulse	Speed monitor	NRPM-M	E22	Circuit: High side, direct-coupled to speed input Output: 200 mA Max. (@12 V) ON voltage: 1.5 V Max. OFF voltage: Load power supply voltage Output withstand voltage: 200 V
		Load factor monitor	LOAD-M	E32	Circuit: High side, PWM port Output: 200 mA (@12 V) ON voltage: 1.5 V Max. OFF voltage: Load power supply voltage Output withstand voltage: 200 V
		Step motor phase A	STPM-A	E31	Circuit: High side Output: 1.0 A Max. (@12 V)
		Step motor phase B	STPM-B	E21	Circuit: High side Output: 1.0 A Max. (@12 V)
		Step motor phase C	STPM-C	E11	Circuit: High side Output: 1.0 A Max. (@12 V)
Step motor phase D		STPM-D	E1	Circuit: High side Output: 1.0 A Max. (@12 V)	
Com- municat ion	Network	CANL	CANL	E39	ISO 11898 (Ver2.0B), 250/500 kbps
		CANH	CANH	E40	
		CAN terminator	RECAN	E30	CAN terminator resistance: 120 Ω when E30 is coupled to CANL (E39)
	Serial	RxD1	RxD	E3	TTL level
		TxD1	TxD	E4	(Dedicated for Yanmar use)

# CONTROL SYSTEM

**Table 2-3 E-ECU I/O description**

I/O	Type	Pin function/name	Symbol	No.	Description
Power supply	Output	Sensor 5V	AVCC	E38	Voltage: $V_{cc} \pm 0.02$ V ( $V_{cc} = 5.0 \pm 0.1$ V) Output: 25 mA Max.
		Sensor GND	GND-A	E28	
		Sensor 12V	AVB	E43	Voltage: Internally coupled to VB Protected against dump surge
	Input	Power supply 12V	VB	E48	Connected to main relay
		Power supply GND	GND	E45	Connected to battery negative terminal
		Power GND	GND-P	E47	
Misc.	Misc.	Boot mode	BOOTSW	E29	Disabled
		-	-	E46	

**Notes:**

- The function of each pin is described later. Do not use the pins for other purposes than intended.
- Yanmar will not disclose nor customize the serial communication protocol.
- When the CAN bus is not used, jumper E30 to E39 to activate the CAN terminator resistor. (This is required for connection of a service tool).  
When the CAN bus is used, configure the bus according to the customer's CAN bus system.
- The intake air temperature, EGR temperature, FO temperature and reserved analog (atmospheric pressure sensor) pins are not used and require no wiring.

**Electrical parts**

**Table 2-4 List of electrical parts**

<b>Part name/number</b>	<b>Functional description</b>	<b>Degree of need *1</b>	<b>Interchangeability *2</b>
E-ECU (Part No.: Model dependant)	Engine control	Essential	Non
FO pump (Part No.: Model dependant)	<ul style="list-style-type: none"> <li>• Fuel injection rack actuation</li> <li>• Rack position detection</li> <li>• Speed detection</li> <li>• CSD valve</li> </ul>	Essential	Non
Coolant temperature sensor (119254-44910)	Engine control (Do not use for other purposes than engine control).	Essential	Non
EGR valve (37 kW Min.) (129927-13900)	Emission control	Essential	Non
Alternator (129423-77200 etc.)	<ul style="list-style-type: none"> <li>• Battery charging</li> <li>• Battery low alarm/indication (connection to E-ECU is optional service)</li> <li>• Recommended: Backup speed detection (pin P)</li> </ul>	Essential (Recommended) *5	Yes
Starter (129900-77010 etc.)	Engine start	Essential	Yes
Starting aid (129915-77050 etc.)	Cold start	Essential	Non
Accelerator sensor (129938-77800)	<ul style="list-style-type: none"> <li>• Engine target speed command</li> <li>• May not be required for generator applications</li> </ul>	Essential (Not required)*6	Yes
Main relay (198461-52950)	Power supply self-holding	Essential	Non
Rack actuator relay (198461-52950)	<ul style="list-style-type: none"> <li>• Overspend prevention</li> <li>• Emergency stop</li> </ul>	Essential	Yes
Starter relay (129927-77920) *4	<ul style="list-style-type: none"> <li>• Starter motor start prevention</li> <li>• Recommended connector: YAZAKI 7223-6146-30 Applicable bracket: 129927-77910</li> </ul>	Essential	Yes
Failure lamp (124732-77720)	<ul style="list-style-type: none"> <li>• E-ECU operation indication (illuminates for 2 sec after power-on)</li> <li>• E-ECU trouble indication (illuminates when a problem occurs)</li> </ul>	Essential	Yes
Sub relay (198461-52950)	Power supply to panel (protection against reverse connection)	Recommended	Yes
Air heater relay (129927-77900 etc.)*4	<ul style="list-style-type: none"> <li>• ON-glow control and the like</li> <li>• Recommended connector: YAZAKI 7223-6146-30 Applicable bracket: 129927-77910</li> </ul>	Recommended	Yes

# CONTROL SYSTEM

**Table 2-4 List of electrical parts**

Part name/number	Functional description	Degree of need *1	Interchangeability *2
Preheat lamp (Part No.: Non)	ON-glow indication (Not required for other than ON-glow indication)	Recommended	Yes
Oil pressure switch (119761-39450)	<ul style="list-style-type: none"> <li>Oil pressure alarm/indication (actuated when a problem occurs)</li> <li>Use an alarm lamp or equivalent device too.</li> </ul>	Essential	Non
Coolant temperature switch (121250-44901)	<ul style="list-style-type: none"> <li>Coolant temperature alarm/indication (actuated when a problem occurs)</li> <li>Use an alarm lamp too.</li> </ul>	Recommended	Yes
Air cleaner (with sensor) (129601-12610 etc.)	<ul style="list-style-type: none"> <li>Air cleaner blockage alarm/indication (actuated when a problem occurs)</li> <li>Use an alarm lamp too.</li> </ul>	Sensor attached on user's request	Yes
Oily water separator (with sensor) (Availability pending)	Oily water alarm/indication (actuated when a problem occurs)	Sensor attached on user's request	Yes
Harness (129927-91020 etc.)	<ul style="list-style-type: none"> <li>Electrical part connection</li> <li>Engine checker connection (Deutsch DTM connector)</li> </ul>	Essential	Yes
Key Switch (194940-52110)	<ul style="list-style-type: none"> <li>ON-glow control</li> <li>Preheat control (as before)</li> </ul>	Recommended	Yes
Fuel feed pump (119225-52102)	<ul style="list-style-type: none"> <li>Fuel feed</li> <li>Auto bleeding</li> </ul>	Essential	Non
Oil pressure sensor (119773-91501)	Oil gauge pressure indication	Available on user's request	Yes
Coolant temperature sensor (124250-49351)	Coolant temperature indication	Available on user's request	Yes

\*1 The degree of need can be divided into the following three categories:

Essential,  
Recommended and  
Available (attachable) on user's request

\*2 "Interchangeability" refers to whether or not commercially available parts can be used in place of Yanmar genuine parts.

Non: Use Yanmar genuine parts. Otherwise, the intended engine performance will not assured.

Yes: Commercially available parts can be used provided that the parts meet requirements specified by Yanmar.

\*3 Shading means that the electrical part or component is specific to the Eco-governor (is not required for a mechanical governor).

\*4 The air heater relay and starter relay have no mounting bracket. Use the recommended relay connector (YAZAKI 7223-6146-30) and bracket (129927-77910).

\*5 It is recommended that the alternator with pin P be used as a backup speed sensing means.

\*6 E-ECU for generator engine application is not standard equipped with the accelerator sensor. The engine speed can be changed using a switch connected to terminals APP-IP3/IP4 of the E-ECU.

The Eco-governor does away with the need for the parts shown in **Table 2-5** that are used for mechanical governors:

**Table 2-5 List of electrical parts not required for the Eco-governor**

Part name	Part number	Remarks
Safety relay	119802-77200 etc.	-
Stop solenoid	119653-77950 etc.	-
Timer	129211-77920	1-sec timer for stop solenoid
Relay	119650-77910	-
Diode	119643-66900	-
Timer	128300-77920	15-sec timer for preheat lamp
QHS controller	129457-77900	The Eco-governor requires the air heater relay instead.

Notes: A timer for preheat lamp is required when the preheat function is used (see 6 "Starting aid").

Commercially available electrical parts used instead of Yanmar genuine parts must meet the minimum requirements specified in **Table 2-6**. Failure to meet these requirements may affect the engine performance or cause malfunction of the E-ECU.

**Table 2-6 Electrical requirements of the commercially available electrical parts used for the Eco-governor**

Part name	Electrical requirements
Accelerator sensor	<ul style="list-style-type: none"> <li>• Sensor output voltage: 0 – 5V (0.7 V Min.. and 3.0 V Max. as standard)</li> <li>• Resistive potentiometer (2.0 kΩ Min..) or thru-hole potentiometer</li> <li>• When a thru-hole potentiometer is used, its current consumption must not exceed 5 V/10 mA.</li> <li>• When the sensor input voltage is lower than 0.2 V or higher than 4.6 V, the sensor is assumed to fail. The input voltage therefore requires to be held within a range of 0.5 – 4.0 V (10 – 80% of the actual effective electrical travel).</li> </ul>
Rack actuator relay	Contact Normally open (a-contact) Rated voltage 12 Vdc Rated load current 12 Vdc/20 A Min..., continuous
Sub relay	Coil current 12 Vdc/200 mA Max. Coil inductance 200 mH Max. Switching durability 10 <sup>6</sup> times or more Other features must be compliant with applicable specifications.
Starter relay	Contact Normally open (a-contact) Rated voltage 12 Vdc Rated load current 12 Vdc/40 A Min., 30 sec. Instantaneous load current 12 Vdc/100 A Min.. Coil current 12 Vdc/300 mA Max. Coil inductance 200 mH Max. Switching durability 10 <sup>6</sup> times or more Other features must be compliant with applicable specifications.

## CONTROL SYSTEM

Table 2-6 Electrical requirements of the commercially available electrical parts used for the Eco-governor

Part name	Electrical requirements
Air heater relay	Contact Normally open (a-contact) Rated voltage 12 Vdc Rated load current 400 W: 12 Vdc/40 A Min., 4 min. (@ 30°C) 500 W: 12 Vdc/50 A Min., 4 min. (@ 30°C) 800 W: 12 Vdc/80 A Min., 4 min. (@ 30°C) 1000 W: 12 Vdc/90 A Min., 4 min. (@ 30°C) Coil current 12 Vdc/1.0 A Max. Coil inductance 200 mH Max. Switching durability 10 <sup>6</sup> times or more Other features must be compliant with applicable specifications.
Failure lamp	Lamp load 12 V - 3.4 W Max.
Preheat lamp	Rush current 12V/3 A-10ms Max.
Harness	Must meet the requirements shown on the standard connection diagrams. (E3-29927-0030, E3-29927-0040)
Coolant temperature switch	Contact Normally open (a-contact)
Air cleaner (with sensor switch)	When connected to E-ECU: Max. current 20 mA or higher Min. current 10 mA or lower
Oily water separator (with sensor switch)	
Key Switch	When the switch is moved from the ON position to the START position, no instantaneous power interruption must occur.
Oil pressure sensor	Not to be connected to the E-ECU.
Coolant temperature sensor	Not to be connected to the E-ECU.

The fulfillment of the requirements shown in the table above does in no way constitute a warranty by Yanmar of user-selected commercially available parts.

**Table 2-7 Requirements of user-selected electrical parts**

<b>Part name</b>	<b>E-ECU pin No.</b>	<b>Requirements</b>	
Stop switch	E15	Contact Max. Min.	Normally closed (b-contact) current 12 Vdc/20 mA or higher current 12 Vdc/10 mA or lower
Load factor monitor	E32	Resistive load	Pulled up to 12 Vdc
Speed monitor	E22	Max. current ON voltage OFF voltage	12 Vdc/200 mA or lower 1.5 V Max. Power supply voltage
Eco-mode lamp (Speed change indication lamp)	E2	Lamp load Rush current	12 Vdc-3.4 W Max. 12 Vdc/3 A-10ms Max.
Block heater relay		Contact Rated voltage Rated load current Coil current Coil inductance Switching durability Other features must be compliant with applicable specifications. When the block heater is connected to the commercial power supply, observe standards and regulations concerning the dielectric withstand voltage and insulation resistance of relay contacts.	Normally open (a-contact) 12 Vdc 100V: 115 Vac/4 A Min., continuous 200V: 210 Vac/2 A Min., continuous 12 Vdc/300 mA Max. 200 mH Max. 10 <sup>6</sup> times or more
Droop switch	E24	Contact	Normally open (a-contact)
Rmax1 switch	E13	Max. current	12 Vdc/20 mA or higher
Rmax2 switch	E14	Min. current	12 Vdc/10 mA or lower
Speed1 switch	E9		
Speed2 switch	E17		
Reverse droop switch	E5		
Speed selection enable switch	E6		

## HARNESS

See the standard connection diagram (E3-29927-0040) for harness arrangement. Yanmar has verified the engine performance with the standard harness. If you want to use a harness other than the standard harness, consult the standard connection diagram for harness design.

Yanmar has made available the standard harness (12997-91020), but cannot supply customized harnesses to individual customers.

### Harness design requirements

Design and implement the harness according to the following instructions. Neglecting these instructions may affect the engine performance or result in malfunction of or damage to the E-ECU. See 13 "Electrical System" for wiring of the battery and starter. See the standard connection diagram (E3-29927-0040) for harness arrangement.

#### [Wiring of the E-ECU]

1. Connect GND directly to the battery negative terminal or battery negative terminal cable by single-point grounding.
2. Supply the main relay with power directly from the battery positive terminal using a cable having a length of 4 m or less. Failure to do so may affect the noise immunity or cold-start resetting process of the E-ECU.
3. The total length of the E-ECU power supply line must not exceed 5 m.
4. Avoid common impedance between the power supply circuit of the E-ECU and that of a large current device such as the starter or air heater. Otherwise, the E-ECU could be reset at cold start.
5. The total length of the rack actuator line must not exceed 10 m.
6. Place the branch of the power supply line for the rack actuator and the EGR valve as close to E-ECU terminal VB as practicable. Otherwise, transmission noise may be developed.
7. Install a reverse connection prevention diode into the main and sub relays or use the Yanmar specified relay (198461-52950) in order to protect the E-ECU rack position sensor.
8. Use a twisted-pair cable for the speed sensor. Use a shielded twisted-pair cable for CAN communication. Otherwise, noise may cause malfunction.
9. When using the CAN terminal resistor inside the E-ECU, connect E30 and E39 with a jumper as short as possible.
10. Do not connect to the main relay other loads than the E-ECU, rack actuator and EGR valve. Supply E-ECU external switches and indicator lamps with power through the sub relay.
11. Do not connect 12-volt/3.4-watt or higher lamps directly to the E-ECU.
12. The minimum contact capacity of switches directly connecting to the E-ECU must not exceed 10 mA.
13. Be sure to locate the failure lamp so as to be easily visible to the operator.
14. Do not connect unintended loads to the coolant temperature sensor of the E-ECU. Doing so may cause CSD or EGR malfunction and deteriorate durability of the engine.
15. When connecting the oil pressure switch (11976-39450) directly to the E-ECU in order to prevent a trouble due to an abnormal oil pressure, insert a dummy load so as to ensure a 0.1-A or higher contact current, or use an oil pressure switch with low contact current (124298-39450).
16. Do not connect to E-ECU terminals loads other than intended or specified.

#### [Wiring of the starting aid]

1. The total length of the starting aid (air heater or glow plug) cable must not exceed 5 m.

## [Key switch]

1. Select a key switch whose B-to-BR circuit (E-ECU power supply circuit) is not open between the ON and START positions. An instantaneous power interruption of 1 ms or longer may reset the E-ECU and hinder the engine from starting.

## [General]

1. Observe the cable and fuse requirements specified on the standard connection diagram.
2. Use electric cables whose heat resistance is appropriate to surrounding thermal conditions.
3. Ensure no water is trapped inside the coupler when plugging the connector.
4. Clamp the harness to appropriate structures so as to prevent swinging due to vibrations.
5. Do not strain the harness clamp.
6. Use joint couplers or butyl tape to ensure waterproofness at joints.
7. Check that no surge current or voltage occurs in normal working conditions or expectedly abnormal conditions.
8. Check that no instantaneous power interruption (6.0 V or lower for 1 ms or more) occurs in normal working conditions or expectedly abnormal conditions.
9. Do not force a measuring or testing probe into the female coupler of the connector.

## Harness clamping

A typical harness clamping method is shown in the **Figure 2-9**.

*Figure 2-9*

## CAN bus termination

As the E-ECU contains a  $120\Omega$  CAN terminator resistor, jumpering RECAN (E30) to CANL (E39) as scheme (b) in **Figure 2-10** enables the CAN signal to be terminated.

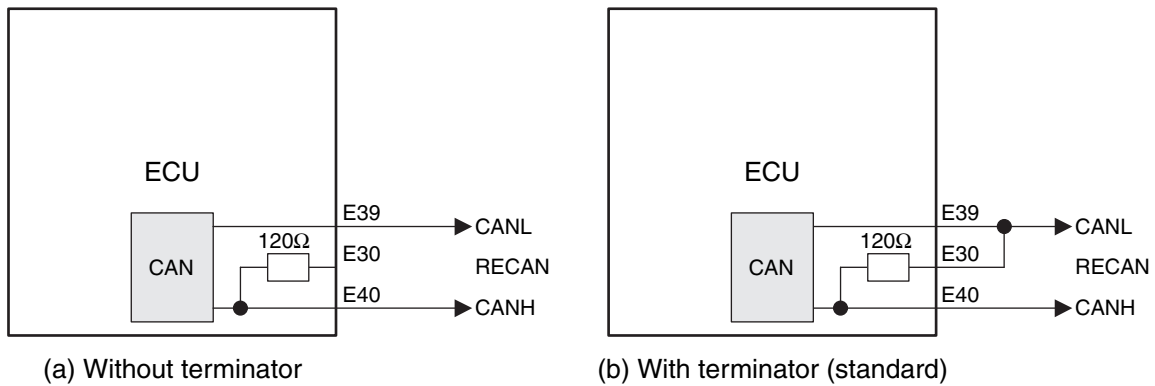

**Figure 2-10** CAN terminator resistor

Even if the CAN bus is not used, select scheme (b) to permit a service tool to be connected to the terminator.

When the CAN bus is used, configure the harness according to the customer's CAN bus system.

# CONTROL FUNCTIONS

## Control software

The functions of the E-ECU software can be divided into the following categories:

1. Driver: Interface between hardware and software
2. Diagnostics: Troubleshooting and event logging of the engine and control hardware
3. Communication: Data exchange among the checker and other E-ECU communication features
4. Engine control: Control of the engine
5. Application: Application interface

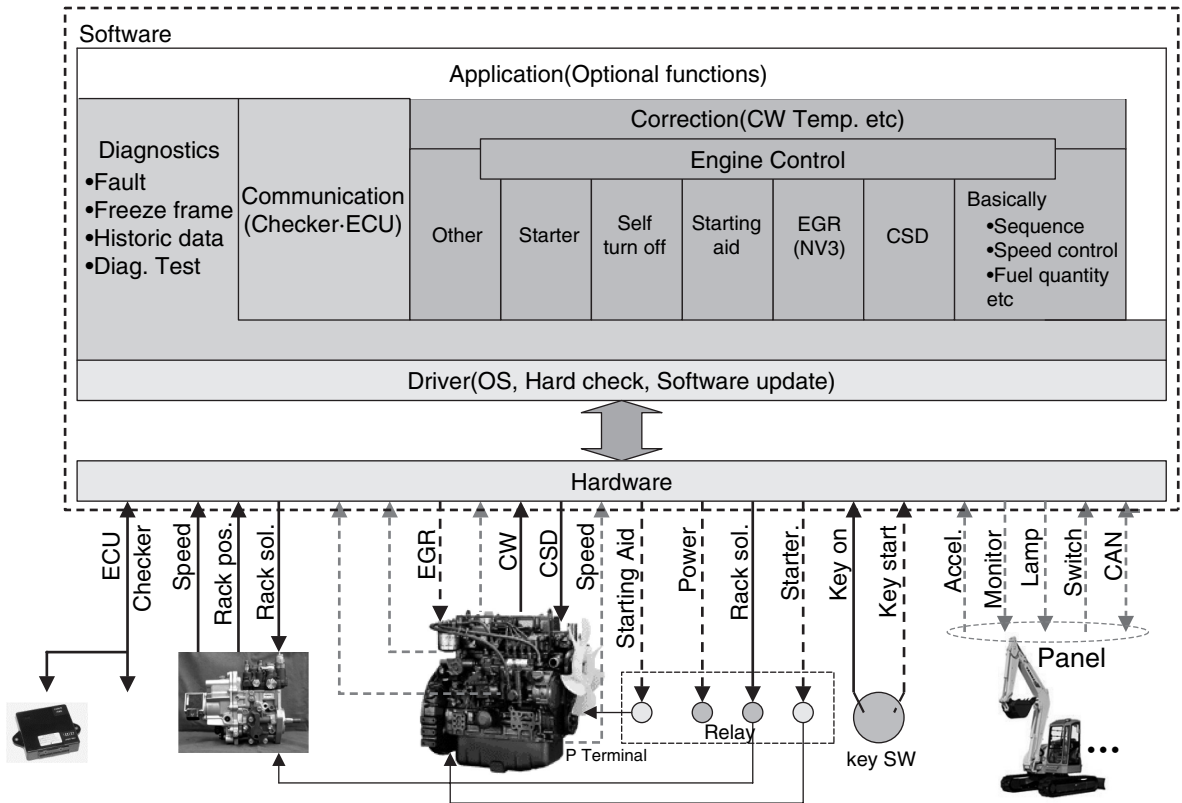

Figure 2-11 E-ECU software configuration

The E-ECU software consists primarily of the following sections:

1. Control program: Engine control logic
2. Engine model-specific control map: Torque characteristics and optional settings
3. Individual data: Correction values of fuel injection rate, power output etc.

## CONTROL SYSTEM

The control program and the engine model-specific control map are maintained as prime constituents by engine models. The individual data is created per each injection pump and engine and maintained as CS data. **Figure 2-12** illustrates constituents of the E-ECU data.

The control program is common to all engine models and cannot be customized per customers.

The engine model-specific control map is composed of two areas: the base area (unchangeable) that defines engine performance including torque characteristics, and the option area that can be customized per customers.

The individual data is injection pump and engine specific and, when the E-ECU is replaced, the data must be copied to a new E-ECU. When the fuel injection pump is replaced, the E-ECU must be updated according to settings of a new pump. The individual data are stored on EEPROM. Loading new individual data to EEPROM automatically refreshes the map from the Flash memory area to the EEPROM area.

Flash memory is a nonvolatile storage, the maximum number of write cycles of which is usually 100, and data stored in this memory is not lost if the E-ECU power turns off. Flash memory differs from EEPROM in that the former does not accept write cycles during engine operation while the latter can be written to, irrespective of whether or not the engine runs. A special device is needed to write data to Flash memory.

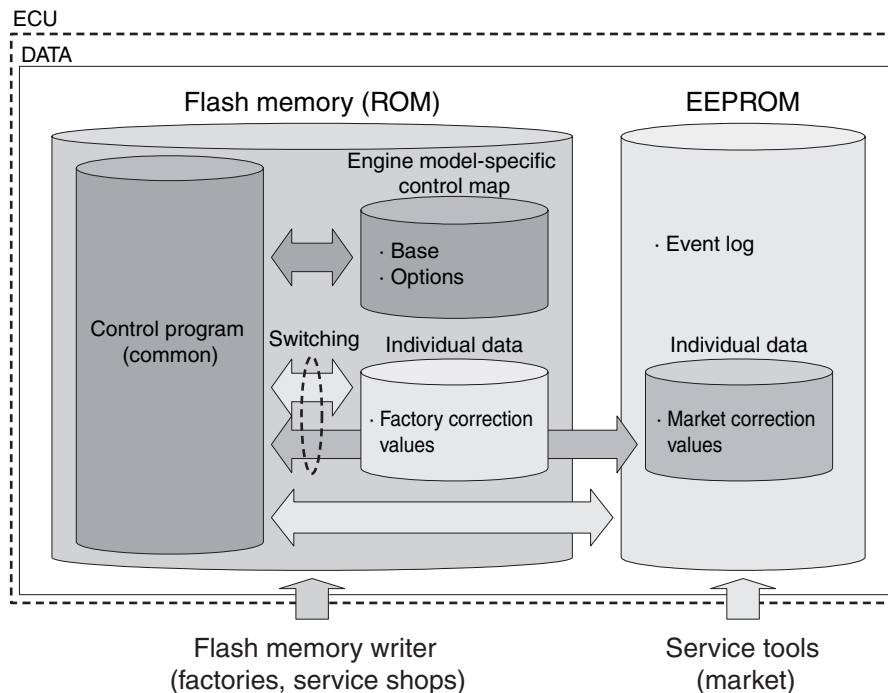

**Figure 2-12 E-ECU data configuration**

**General**

**Speed sensor input**

The Eco-governor detects the engine speed with 12 pulsers attached to the camshaft. See **Figure 2-13**.

Assuming that the frequency of pulses provided by the pulsers is  $f_p$  [Hz], the engine speed  $N$  rpm [ $\text{min}^{-1}$ ] is given by

$$N_{rpm}[\text{min}^{-1}] = (f_p \times 2 / 12) \times 60 = 10 \times f_p[\text{Hz}]$$

The engine speed fluctuates periodically due to compression and explosion strokes. As to a 4-cylinder engine, 3 pulses represent cyclic fluctuation for one cylinder. As to a 3-cylinder engine, 4 pulses represent cyclic fluctuation for one cylinder.

The Eco-governor averages cyclic fluctuations for one cylinder, thus minimizing the effect of cyclic fluctuations in engine speed and ensuring stable measurement.

The E-ECU uses a counter with a resolution of  $0.125 \mu\text{s}$  to measure the number of pulse signals. Assuming that the measured number of pulse signals is  $N$  and the number of cylinders is  $C$ , the actual engine speed is given as follows:

$$f_p[\text{Hz}] = (12 \div C) / N \times 0.125 \times 10^{-6}$$

$$N_{rpm}[\text{min}^{-1}] = 960 \times 10^6 / C / N$$

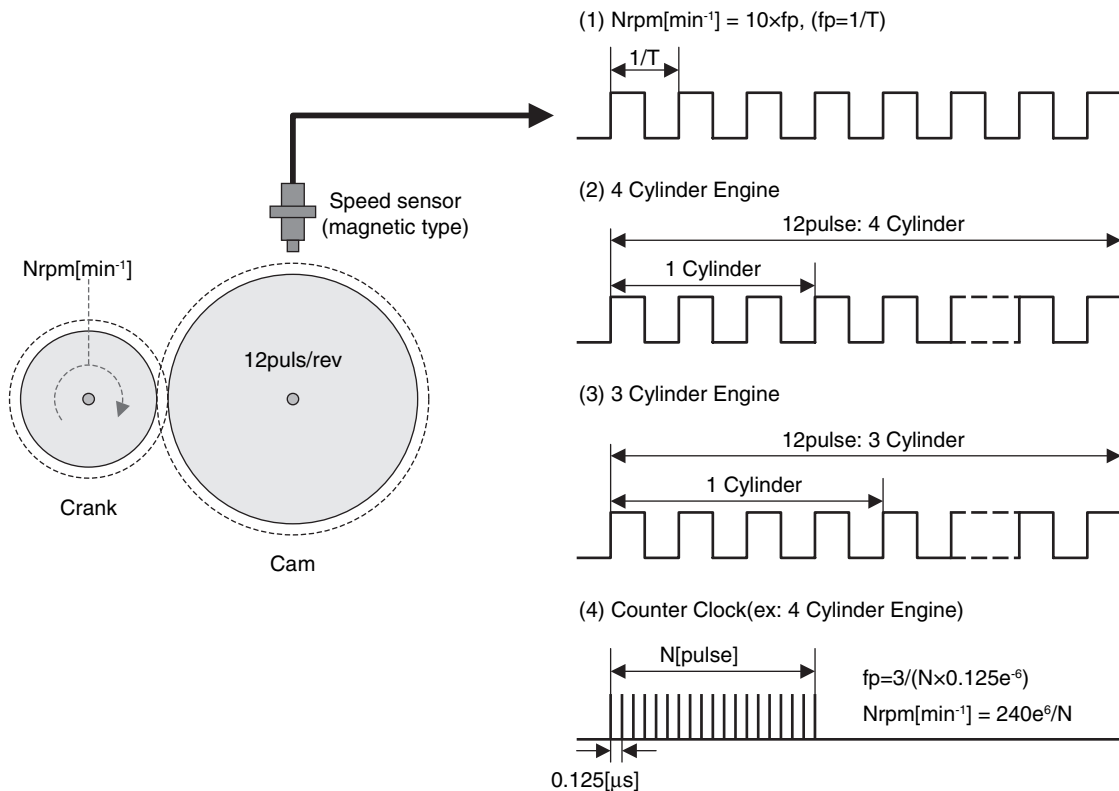

**Figure 2-13** Detection of engine speed

# CONTROL SYSTEM

## Rack position sensor input

The Eco-governor controls the fuel injection quantity by adjusting the rack position of the fuel injection pump. The rack position is converted into voltage by the rack position sensor, and the voltage signal is applied to E-ECU terminal RPS and sent to an AD converter. The AD converter converts the input voltage of 0 to 5 volt into an AD value of 0 to 1023. See **Figure 2-14**.

The Eco-governor controls the maximum and minimum rack positions and calculates the load factor on the basis of this AD value.

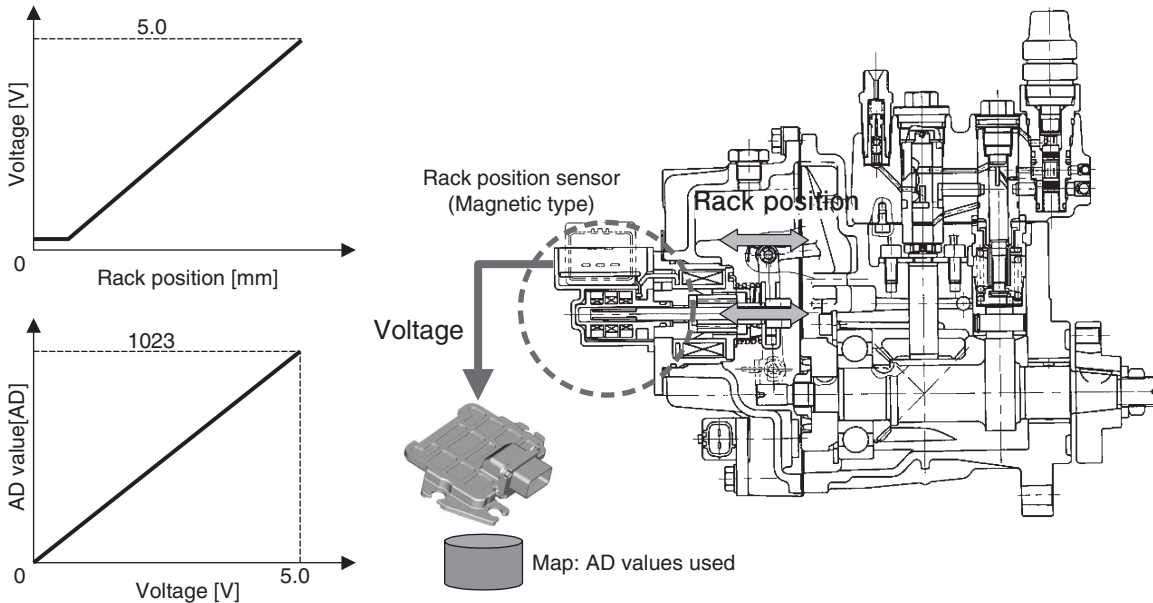

**Figure 2-14** Detection of rack position

## Coolant temperature sensor input

The input characteristics of the coolant temperature sensor are shown in **Figure 2-15**. As in the case of the rack position sensor, the input voltage of 0 to 5 volt is converted into an AD value of 0 to 1023. As is clear from the figure, the thermistor resistance decreases with increasing temperatures.

The measurement error of the coolant temperature sensor is approximately  $\pm 3^{\circ}\text{C}$  at  $0^{\circ}\text{C}$  and  $\pm 6^{\circ}\text{C}$  at  $110^{\circ}\text{C}$ . The coolant temperature sensor has been designed so that it provides high measurement accuracy at relatively low temperatures to allow low-temperature control of CSD etc.

The E-ECU converts the input voltage into temperatures by mapping. Connecting a thermistor with different characteristics to the sensor or connecting an unintended load to the thermistor circuit will affect the relationship between input voltage and temperature, resulting in failure to perform correct temperature measurement. Do not connect a coolant temperature sensor other than the Yanmar genuine sensor to terminal TW (E25 - E28) of the E-ECU.

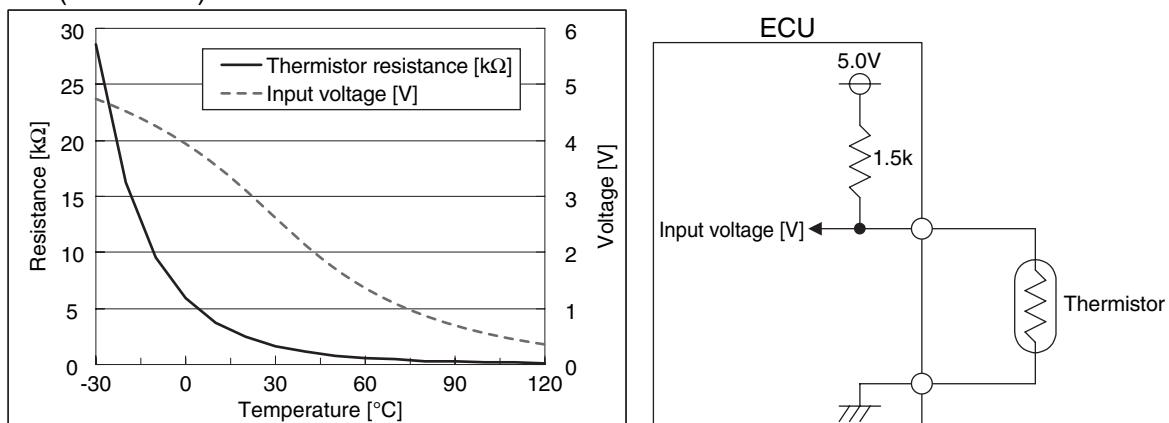

**Figure 2-15** Characteristics of the coolant temperature sensor

A high-accuracy coolant temperature sensor will also be able to connect to terminal TFO (E16). The measurement error of the high-temperature coolant temperature sensor will be approximately  $\pm 2^{\circ}\text{C}$  at 0 to  $110^{\circ}\text{C}$ .

The high-accuracy coolant temperature sensor can double as a coolant temperature switch (121250-44901) whose measurement accuracy is required to be  $110 \pm 3^{\circ}\text{C}$ . (The high-accuracy coolant temperature sensor is now under development).

When the coolant overheat alarm is used as shown in **Table 2-20**, it is recommended to use the high-accuracy temperature sensor.

## Accelerator sensor input

The Eco-governor uses the input voltage from the accelerator sensor or the input value through CAN communication to calculate the target engine speed.

The input voltage from the accelerator sensor is converted into a speed value between the low idling speed and the high idling speed. See **Figure 2-16**. By default, 0.7 V signal is converted into the high idling speed and 3.0 V signal into the low idling speed. Input voltages corresponding to the low and high idling speeds can be adjusted provided that they are within the range of 0.2 to 4.6 V. If the input voltage from the accelerator sensor is out of the above range, the E-ECU detects an accelerator sensor failure.

The input voltages can also be selected so that the gradient of the input voltage line segment between the high and low idling speed points is reversed.

See "Application interface outline" for details on accelerator sensor setting.

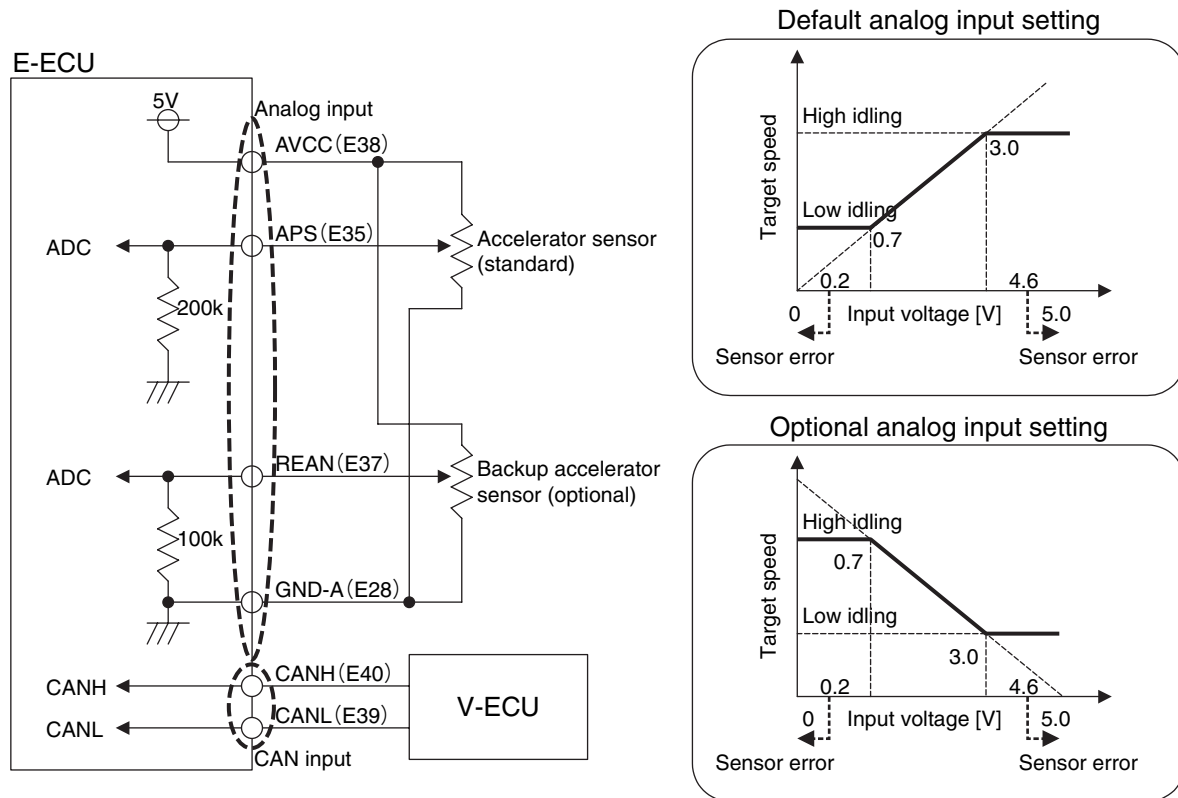
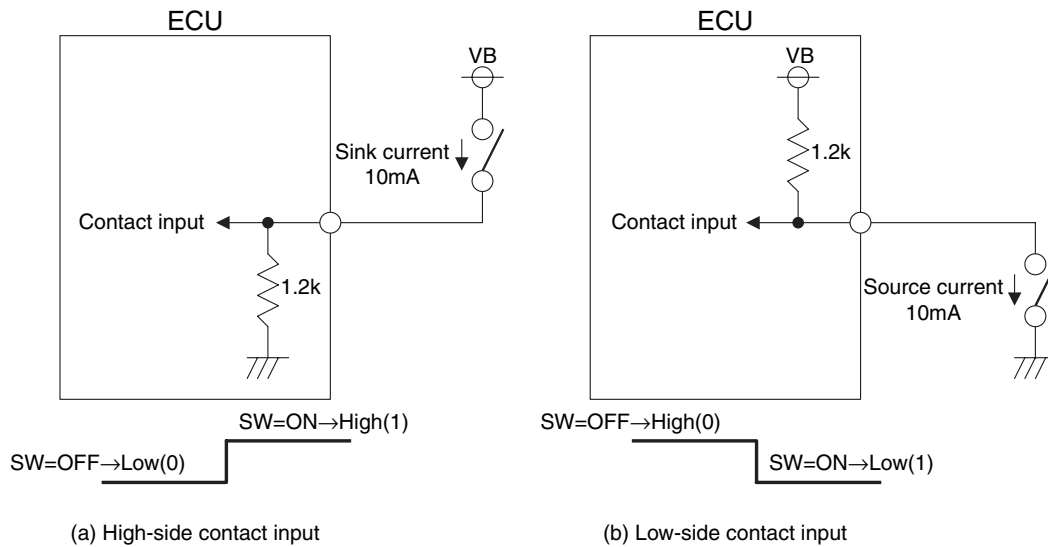

**Figure 2-16 Accelerator sensor input**

# CONTROL SYSTEM

## Contact input

There are two schemes for contact input of the E-ECU: High-side input and Low-side input. See **Figure 2-17**. The contact input of the E-ECU has been designed with the same sink current and source current of 1.0 mA typ.



**Figure 2-17** Contact input schemes and input logics

There are two types of switch contacts connected to contact inputs: Normally open (NO) contact and normally closed (NC) contact.

**Figure 2-18** illustrates the voltage levels at the input terminal for the high-side contact input. When the switch turns on, the input terminal goes high for the switch with NO contact and goes low for the switch with NC contact.

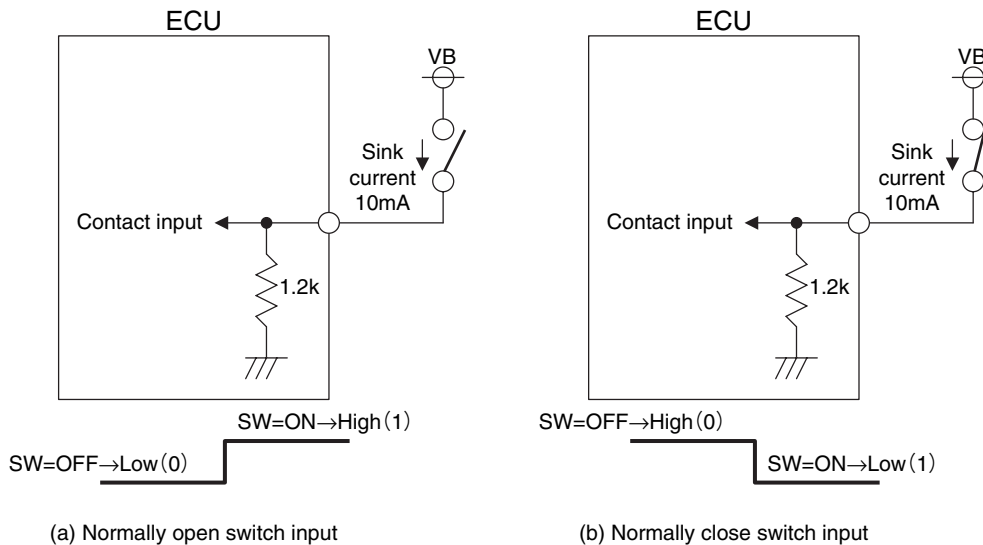

**Figure 2-18** Switches for high-side contact input

Figure 2-19 illustrates the voltage levels at the input terminal for the low-side contact input. When the switch turns on, the input terminal goes low for the switch with NO contact and goes high for the switch with NC contact.

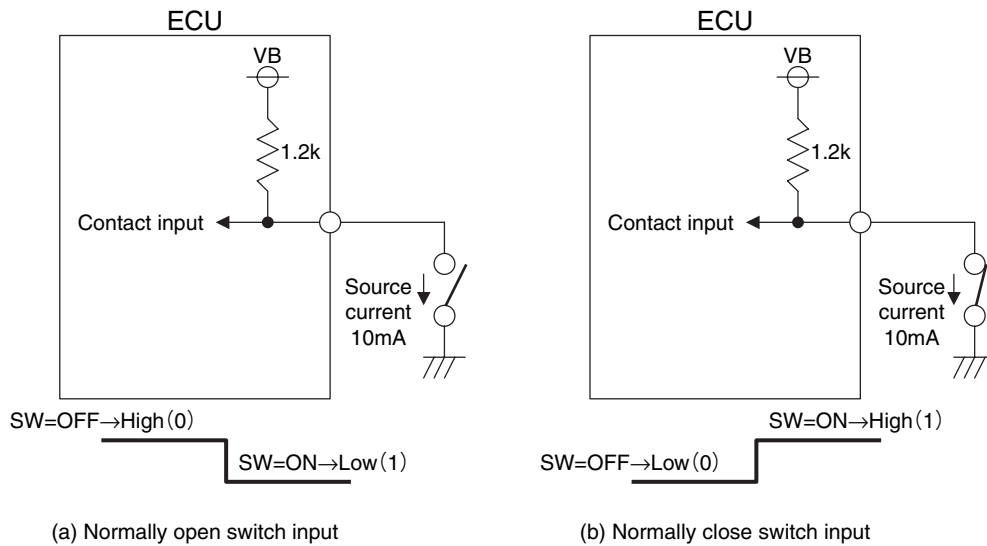

Figure 2-19 Switches for low-side contact input

Unless otherwise specified, this manual assumes that switches with NO contact are used. This means that turning on the switch activates the corresponding function.

Selection of NO switch or NC switch is allowed by using mapping plug-ins. Table 2-15 lists contact input terminals for which a NO or NC switch can be selected.

Contact output

There are two schemes for contact output of the E-ECU: High-side output and Low-side output. See Figure 2-20 See Table 2-3 for the allowable sink current and source current of the contact outputs.

In this manual, output transistor ON is referred to as logical "1" and output transistor OFF as logical "0". In the high-side output scheme, the output terminal goes high when the transistor turns off. In the low-side output scheme, the output terminal goes low when the transistor turns off.

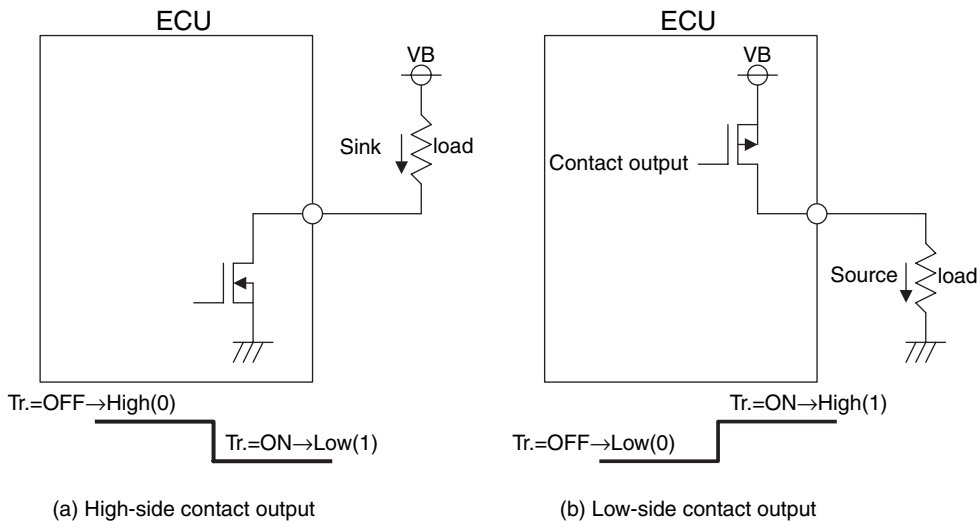

Figure 2-20 Contact output schemes and output logics

# CONTROL SYSTEM

## Rack actuator output

The rack actuator output is a high-side output. See **Figure 2-21**.

The E-ECU adjust the magnitude of current flowing through the rack actuator solenoid by shortening or lengthening the ON-duration of the output transistor. The rack position of the fuel injection pump varies depending on the magnitude of current flowing through the rack actuator.

This technique where the ON duration of the transistor is changed to provide current control is called PWM (Pulse Width Modulation). The PWM control period of the Eco-governor E-ECU is 0.4 ms.

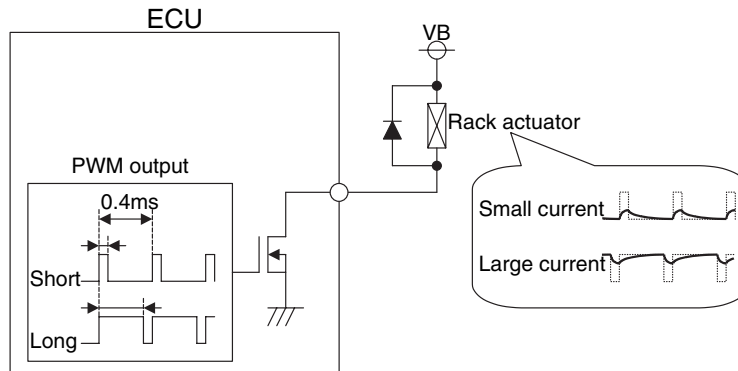

**Figure 2-21** Rack actuator output

## EGR valve output

The EGR valve output is a high-side output. See **Figure 2-22**.

The EGR valve is driven by a stepping motor. This stepping motor adopts two-phase excitation and requires holding current to keep the valve stopped. "Two-phase excitation" means that the solenoid is supplied with two-phase current and "holding current" does that the solenoid is always energized. The motor of the EGR valve is consequently approx. 24 watt heated even while the engine is at rest.

The E-ECU turns on or off the output transistors in the sequence shown in **Figure 2-22**, thereby driving the solenoids for the stepping motor and opening/closing the EGR valve. The speed of the valve open/close operation depends on the on/off speed of the transistors. The EGR valve opens at 125 pps (pulses per second: the number of steps taken per second) and closes at 250 pps (20 pps for 10 steps before full close).

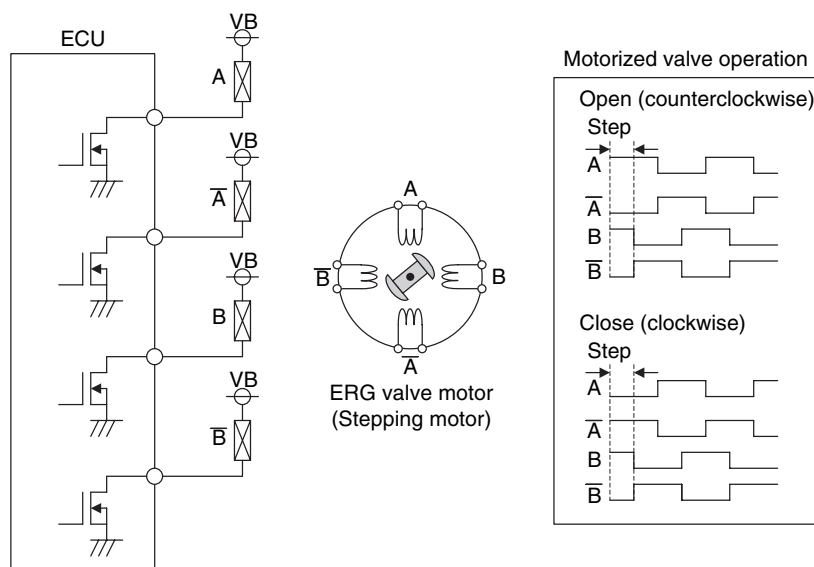

**Figure 2-22** EGR valve driving mechanism

Control map

As already mentioned in "Control software", the E-ECU software can be divided into the control program, engine model-specific control map and individual data. This section describes the engine model-specific control map.

Map data can be categorized into the following types:

- 1. Flag type: Conditionally branched based on 0, 1, 2, ...
  - Ex. : ON-glow control flag
  - 0: Enables control.
  - 1: Disables control.
- 2. Numeric type: Numerics are used for control.
  - Ex. : Alternator-pulley ratio
  - 169: It is assumed that the alternator speed is 1.69 times the engine speed.
- 3. 1D type: Used to set a value in x coordinate.
  - (See **Figure 2-23** (a) in the figure below).
- 4. 2D type: Used to set values in x and y coordinates.
  - (See **Figure 2-23** (b) in the figure below).

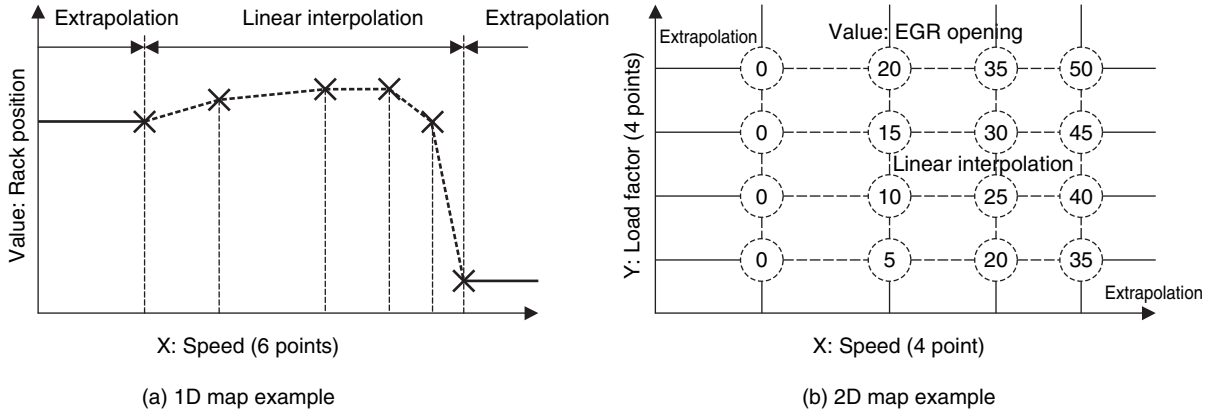

Figure 2-23 1D/2D map and interpolation

1D and 2D maps are treated as follows:

- Values between map coordinate axes are linear interpolated.
- When there are values outside map coordinate axes, the outermost value is held. (Extrapolation)
- Decimal places are truncated.
- The number of map coordinate axes is limited to a predetermined value.

## Engine control - General

### Self-holding of the E-ECU power

The E-ECU saves engine logs including faults and running hours in the internal EEPROM. And it has a power self-holding feature that allows the power supply to be held until the engine logs are completely saved in EEPROM.

The power self-holding feature also allows the E-ECU to move the EGR valve to open a bit from the full-close position when the key switch is turned off, preventing the valve from sticking while the engine is at rest.

To implement the power self-holding feature, the main relay and the rack actuator relay must be connected as shown in **Figure 2-4**.

This feature can also be activated through CAN communication. See CAN communication specifications for details.

### Start control

The engine start sequence is shown in the figure to the right. The E-ECU performs rack self-diagnostics directly after power on. At this time, the starter relay prevents the starter motor from starting until the diagnostic is completed.

Next, when ON-glow control is alive (default), the time of energization of the starting aid relay is adjusted according to the coolant temperature. The preheat lamp should illuminate while ON-glow control is in progress.

After ON-glow control is complete, the E-ECU waits until the key switch is moved to the START position.

When the key switch is moved to START or the engine speed reaches  $240 \text{ min}^{-1}$ , rack position control on start takes place to move the rack to a predefined position.

Having detected that the engine speed reaches  $600 \text{ min}^{-1}$ , the E-ECU goes to speed control mode. In this mode, the rack position is controlled so that the engine runs at a speed that matches the speed command from the accelerator.

When the engine speed is reduced to less than  $240 \text{ min}^{-1}$  or the key switch is turned off, the engine will stop.

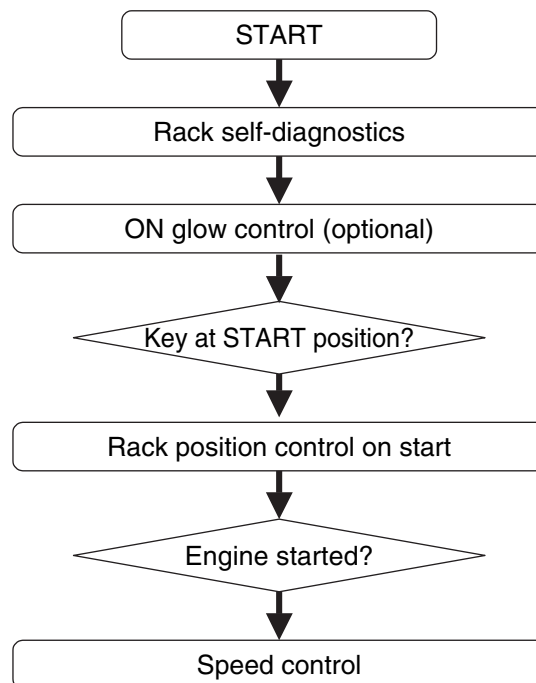

**Figure 2-24**

## Torque curve and engine regulation

Standard engine torque curves are outlined in **Figure 2-25**. Details of the curves varies depending on the engine models.

For the Eco-governor, engine regulations are available in the following variations:

- (a) Isochronous  
The engine speed is constant, regardless of the load (regulation 0%).
- (b) Virtual droop (torque curve of base engine)  
Approx. 7% regulation regardless of the engine speed. Regulation other than 7% is available as a special option. Contact Yanmar for details.  
The engine speed is kept until a torque equivalent to a load factor of approx. 30% is reached, in order that the idling (non load) speed does not fluctuate even if installation of the engine on a machine causes some power loss.  
Even when virtual droop is active, it is possible that the engine speed does not decrease to lower than the low-idling speed. (Optional).
- (c) Reverse droop  
Reverse droop provides fine speed control to the engine in a low speed range, preventing engine stalling. This can be active with an external switch.

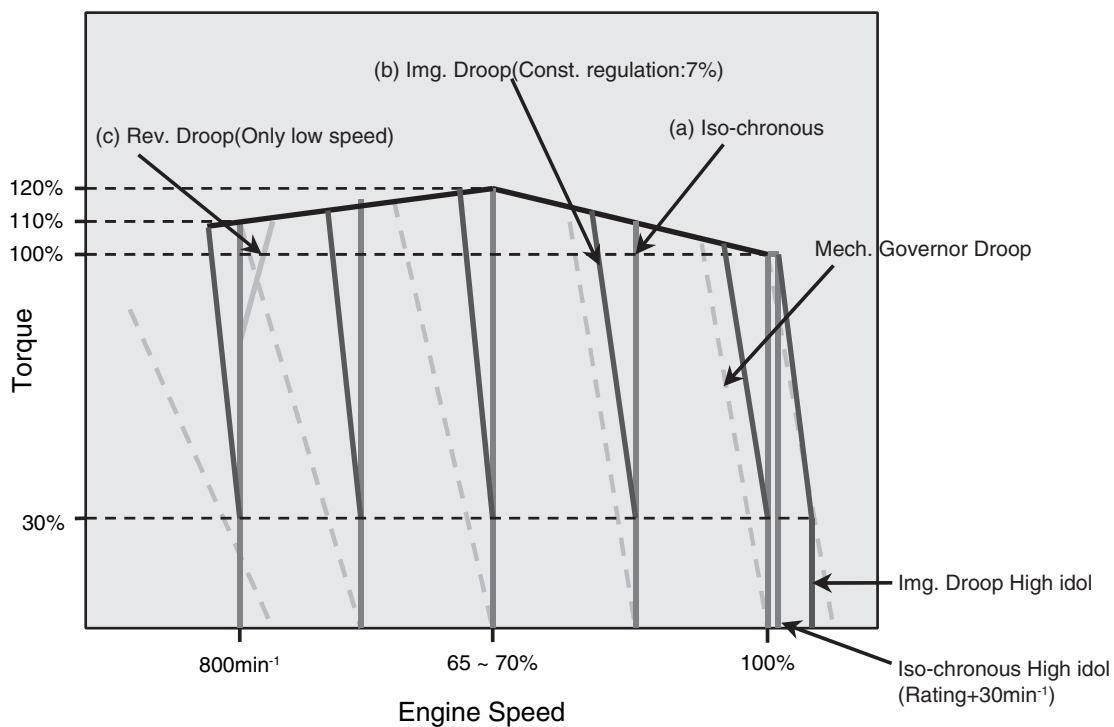

**Figure 2-25 Standard torque curves**

# CONTROL SYSTEM

Switching between "isochroous" and "virtual droop" can be done with an external switch or through CAN communication, while the engine is running. Selection of either one as default is allowed on customer's request.

Switching between "isochroous" and "virtual droop" can be done even while the engine is running. "Reverse droop" can also be enabled or disabled with an external switch or through CAN communication while the engine is running. Selection of "reverse droop enabled" or "reverse droop disabled" as default is allowed on customer's request.

The Isochroous-Virtual droop switching and reverse droop enabling/disabling connection diagram is shown in **Figure 2-26**.

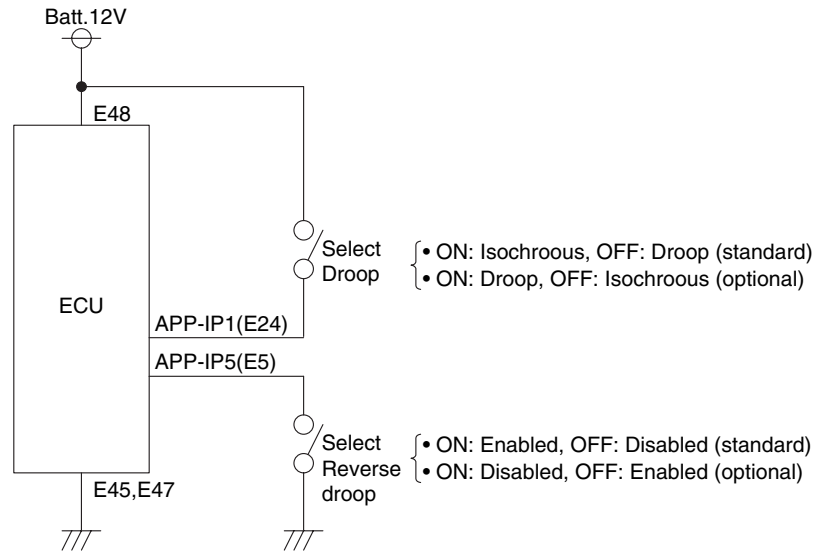

**Figure 2-26 Isochroous-Droop switching and reverse droop enabling/disabling connection**

**Figure 2-27** summarizes the characteristics of virtual droop. Contact Yanmar for change in regulation.

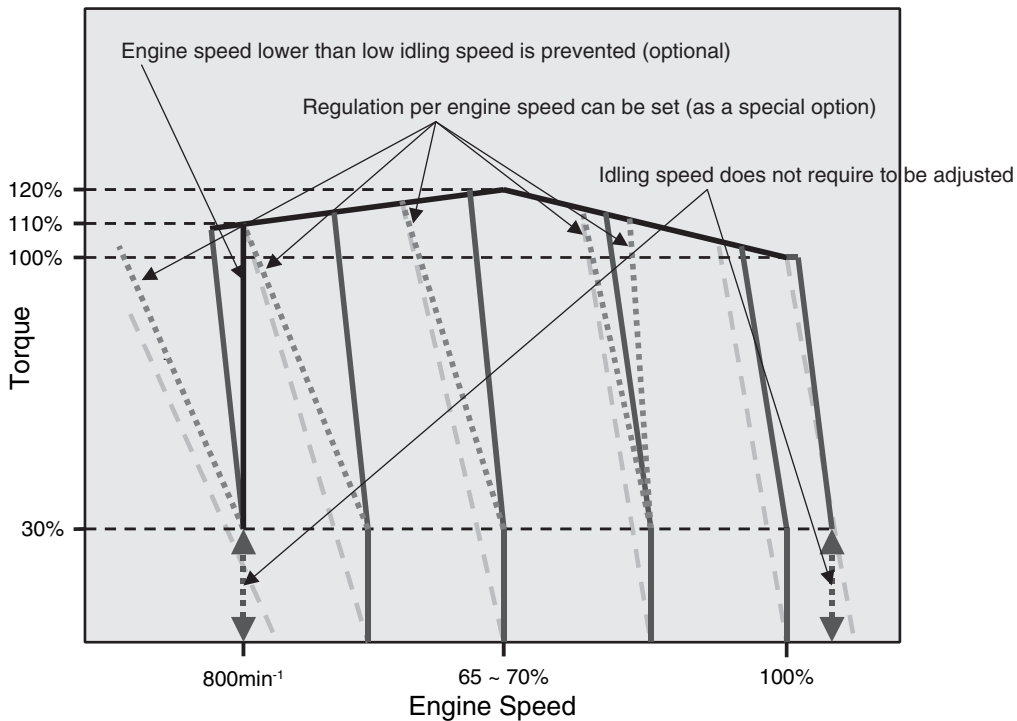

**Figure 2-27 Characteristics of virtual droop**

Caution: We cannot accept an order for implementation of torque curves other than shown above.

## Speed control

The target engine speed is defined by input signals from the accelerator sensor or through CAN communication. **Figure 2-28** shows the flow of defining the target engine speed. Elements and optional settings in the flow will be described later.

The accelerator input selection feature allows certain accelerator sensors to be selected as input source among others depending on the setting and status of accelerator sensors. (See page 2-31 for details).

The engine speed selection feature allows the target speed to be changed depending on the status of external switches APP-IP3/IP4/IP6. (See page 2-49 for details).

The idling speed up feature allows the low idling speed of the engine to be raised depending on the coolant temperature. (See page 2-54 for details).

The blue and white smoke suppression feature allows the high idling speed of the engine to be raised depending on the coolant temperature. (See page 2-54 for details).

The governor control feature calculates the target engine speed for virtual droop. (See page 2-46 for details).

The accelerator filter suppresses fluctuations in target engine speed, minimizing overshoot or undershoot. (See page 2-55 for details).

The low/high idling speed limiting feature checks if the target engine speed is in the range of the low idling speed to the high idling speed and adjusts it if required.

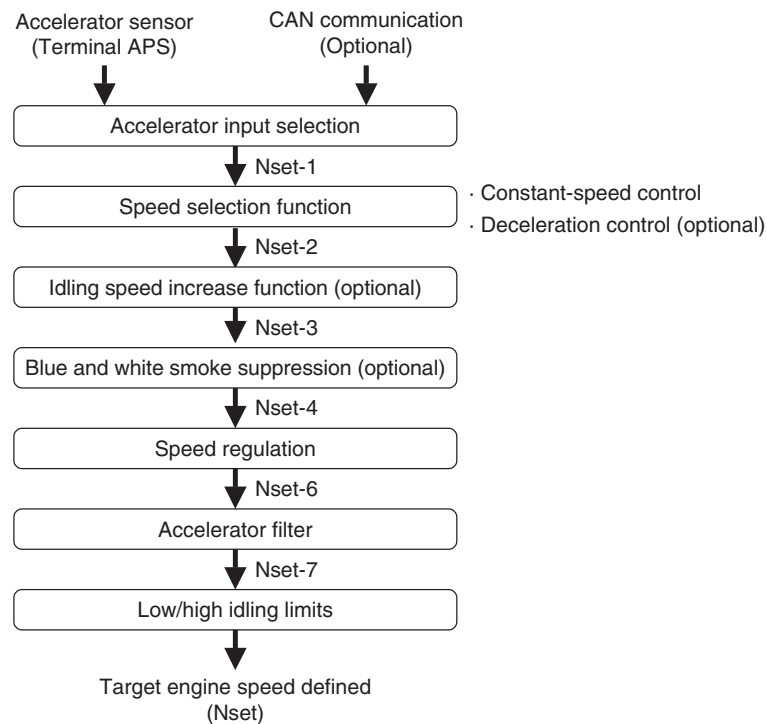

**Figure 2-28** Flow of defining the target engine speed

# CONTROL SYSTEM

Figure 2-29 shows the engine speed control block diagram.

## [Speed control]

The deviation of the actual engine speed ( $N_{rpm}$ ) from the target engine speed ( $N_{set}$ ) is used to determine the target rack position ( $R_{set}$ ) with PID control. The target rack position is the basis for providing torque limitation or rack motion delay adjustment for transition control (described later).

## [Rack position control]

The deviation of the actual rack position ( $R_{act}$ ) from the target rack position ( $R_{set}$ ) is used to determine the target current ( $I_{set}$ ) with PID control. To check that the control system of the Eco-governor works properly, use the service tool to make sure that  $R_{act}$  is approximately equal to  $R_{set}$  while the engine is running.

## [Current control]

The deviation of the actual current ( $I_{act}$ ) from the target current ( $I_{set}$ ) is used to determine the target PWM duty ratio with PID control. Current control helps improve the motion responsiveness of the rack or facilitate diagnostics of the rack solenoid

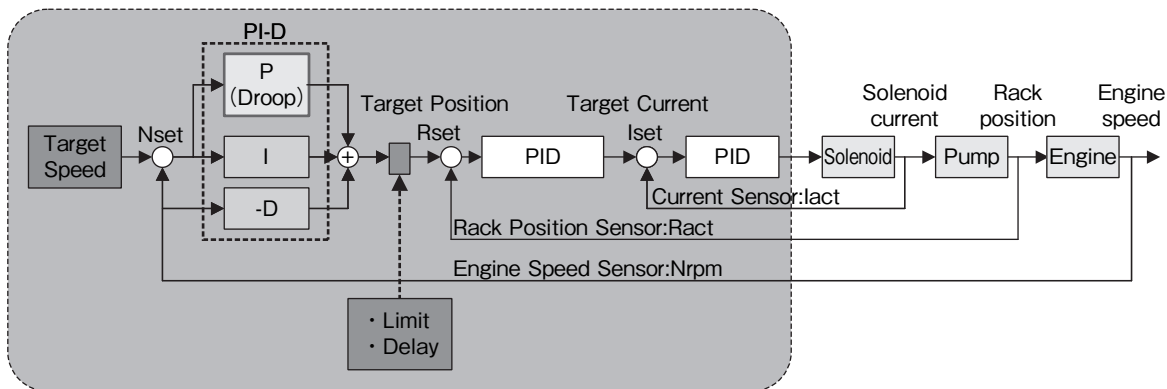

Figure 2-29 Engine speed control block diagram

## Transition control

The Eco-governor delays the rack motion at engine start or during acceleration in order to minimize the emission of black smoke. See Figure 2-30.

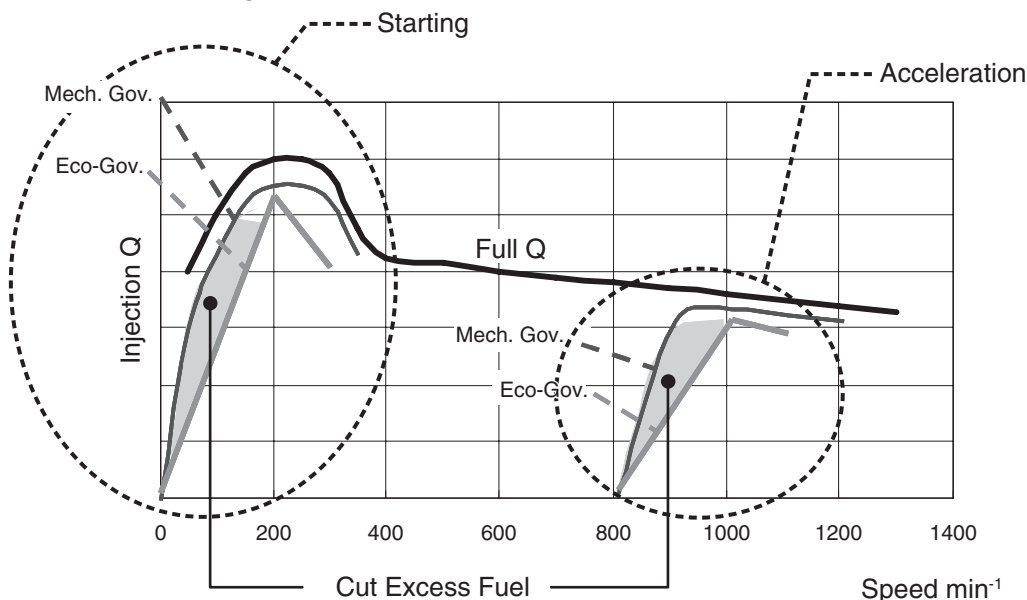

Figure 2-30 Transition control

## EGR control

The Eco-governor uses an electronic-controlled EGR valve to reduce the emission of NO<sub>x</sub> from 37 kW or more engines.

The EGR valve is driven by a stepping motor. The opening (0 - 54 steps) of the EGR valve is adjusted depending on the engine speed and load factor so as to control recirculation of exhaust gas. **Figure 2-31** outlines the relationship between the number of steps and the flow rate.

The EGR valve does not open when the coolant temperature is lower than 60°C. This is because low temperature corrosion due to condensation of exhaust gas components must be prevented.

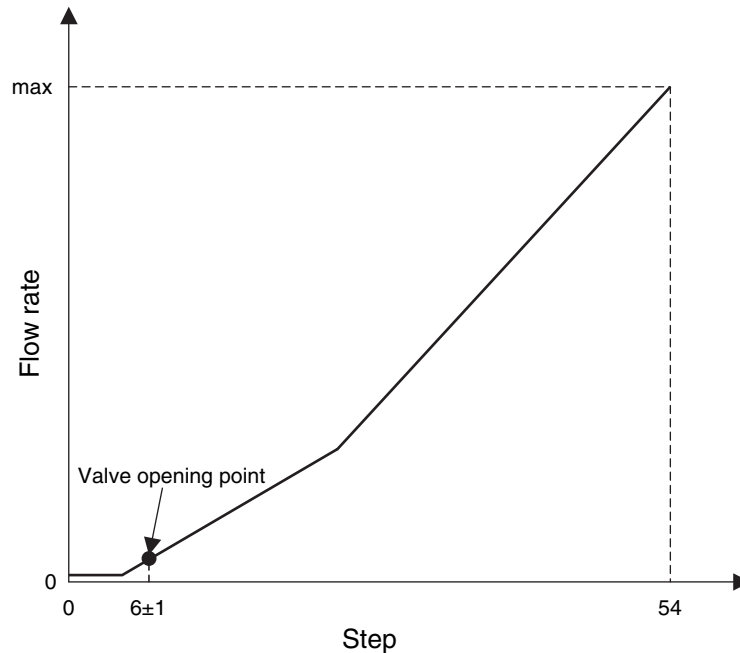

**Figure 2-31 EGR valve characteristics**

## CSD control

The fuel injection pump (MP pump) has a CSD valve mechanism that allows the fuel injection timing to advance and the injection quantity to increase, thereby improving the cold start performance of the engine.

The Eco-governor has a solenoid valve CSD where the CSD can be opened or closed with a valve solenoid. The E-ECU opens the CSD valve when the coolant temperature sensor detects that the coolant temperature is 5°C or lower at cold start. The CSD valve closes when the coolant temperature rises to 5°C or five minutes have elapsed after engine started.

# CONTROL SYSTEM

## Calculation of load factor

The load factor of the engine is determined as a percentage from the rack position at idling ( $R_{idl}$ ), maximum rack position ( $R_{max}$ ), minimum rack position ( $R_{min}$ ) and actual rack position relative to  $R_{min}$  ( $R_{act}$ ). See **Figure 2-32**.

The calculated load factor is delivered as a PWM signal from an E-ECU terminal or through CAN communication.

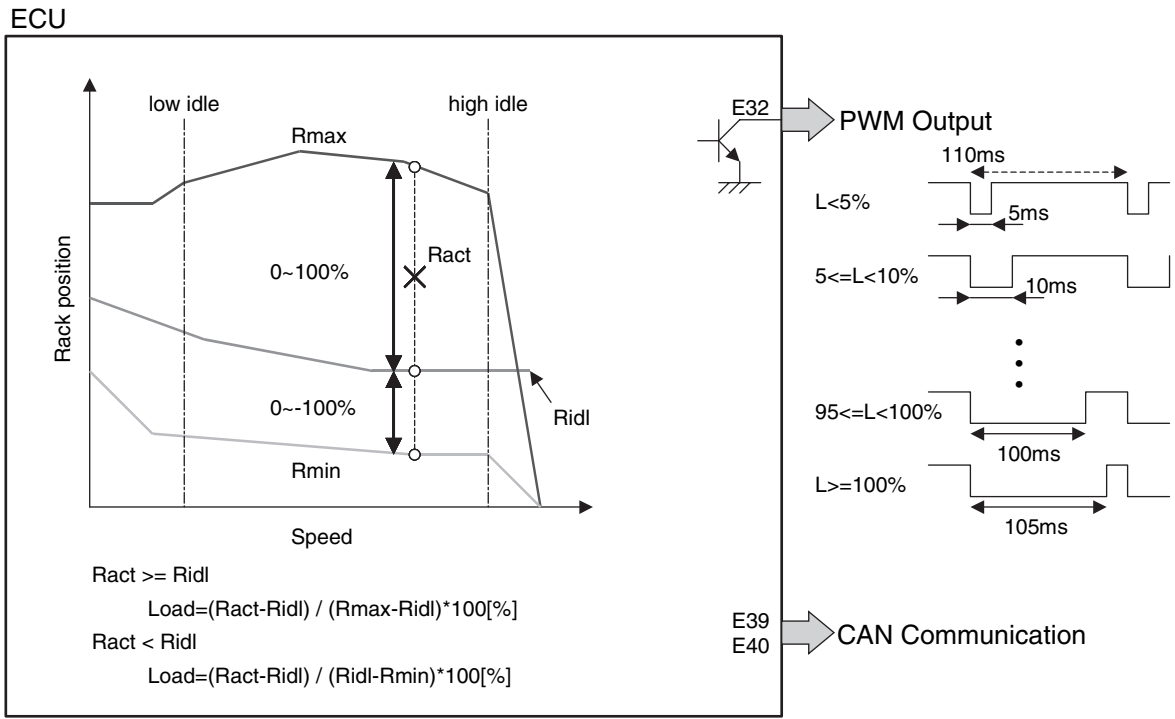

**Figure 2-32 Calculation of load factor**

## Application interface outline

### Accelerator input selection

Accelerator sensors are available in three types: standard (analog voltage), backup (analog voltage) and CAN communication (communication command) types. See **Figure 2-16**. Using accelerator sensor setting flags allows combined use of these sensors.

In standard mapping (1), the main accelerator sensor is solely used. In generator standard mapping (0), selecting a contact input can switch the engine speed without the use of accelerator sensors.

In option 2 mapping (2), a higher speed setting is selected from the main accelerator sensor input and the backup sensor input. If one of the two sensors fails, the other is used to control the engine speed.

In option 3 mapping (3), the engine target speed is commanded via CAN communication.

In option 4 mapping (4), the engine target speed is commanded via CAN communication, and if CAN communication fails, the main accelerator sensor input is used for engine speed control.

When an accelerator sensor failure is detected while the engine is running, a value immediately before the failure is used for engine speed control. Otherwise, the engine runs at a speed (1500 min<sup>-1</sup> by default) determined by the accelerator sensor failure flag.

**Table 2-8 Accelerator sensor setting flags**

Mapping	Main accelerator sensor APS (E35)	Backup accelerator sensor REAN (E37)	CAN input (E39,E40)	Preference
0 (Generator standard)	×	×	×	Contact inputs available: • APP-IP6 (E6) • APP-IP3 (E9) • APP-IP4 (E17)
1 (Standard)	○	×	×	-
2	○	○	×	• Sensor with higher speed setting • Normal sensor
3	×	×	○	-
4	○	×	○	CAN input

The accelerator position sensor input (APS: E35) and the backup analog sensor input (REAN: E37) can be flagged so that the corresponding sensor types are changed. See **Table 2-9**. These inputs have been flagged so that accelerator sensor signals (flag setting: 1) and foot pedal signals per SAE J1843 (flag setting: 2 - 4) can be applied.

When these inputs are open, they must be flagged to 0 to disable sensor failure detection.

The backup analog sensor input (REAN: E37) will be able to connect to an atmospheric pressure sensor (flag setting: 5). (Highland compensation feature pending).

**Table 2-9 Analog input assignment**

Assignment flag		Sensor type
APS: E35	REAN: E37	
0 (Generator standard)	0 (Standard)	No connection (Sensor failure detection disabled)
1 (Standard)	1	Accelerator sensor
2	2	Foot pedal (SAE J1843 configuration) Analog + APP-IP2: NO & APP-IP7: NC

**Table 2-9 Analog input assignment**

Assignment flag		Sensor type
APS: E35	REAN: E37	
3	3	Foot pedal (SAE J1843 configuration) Analog + APP-IP2: NO
4	4	Foot pedal (SAE J1843 configuration) Analog + APP-IP7: NC
-	5	Atmospheric pressure sensor

To connect the accelerator position sensor input (APS: E35) and the backup analog sensor input (REAN: E7) to the foot pedal (flag setting: 2 - 4), APP-IP2: E14 and APP-IP7: E13 must be configured to enable reception of signals from the foot pedal switch. In addition, APP-IP2: E14 and APP-IP7: E13 must be configured to enable connection with an NO switch and NC switch respectively. (Set APP-IP2 to NO and APP-IP7 to NC. See **Table 2-15**. When the flag is set to 2, APP-IP2 and APP-IP7 must be set to NO and NC respectively. When the flag is set to 3, APP-IP2 must be set to NO. When the flag is set to 4, APP-IP7 must be set to NC).

**Figure 2-33** shows the foot pedal operation and engine speed. When the flag is set to 2, the input voltage at terminal APS or REAN is effective only when APP-IP2: NO is low and APP-IP7: NC is high. Otherwise, the engine runs at low idling speed.

When the flag is set to 3, the input voltage at terminal APS or REAN is effective only when APP-IP2: NO is low. Otherwise, the engine runs at low idling speed.

When the flag is set to 4, the input voltage at terminal APS or REAN is effective only when APP-IP7: NC is high. Otherwise, the engine runs at low idling speed.

When two foot pedals are used, APS: E35 and REAN: E37 must be flagged to 3 and 4 (or vice versa) respectively.

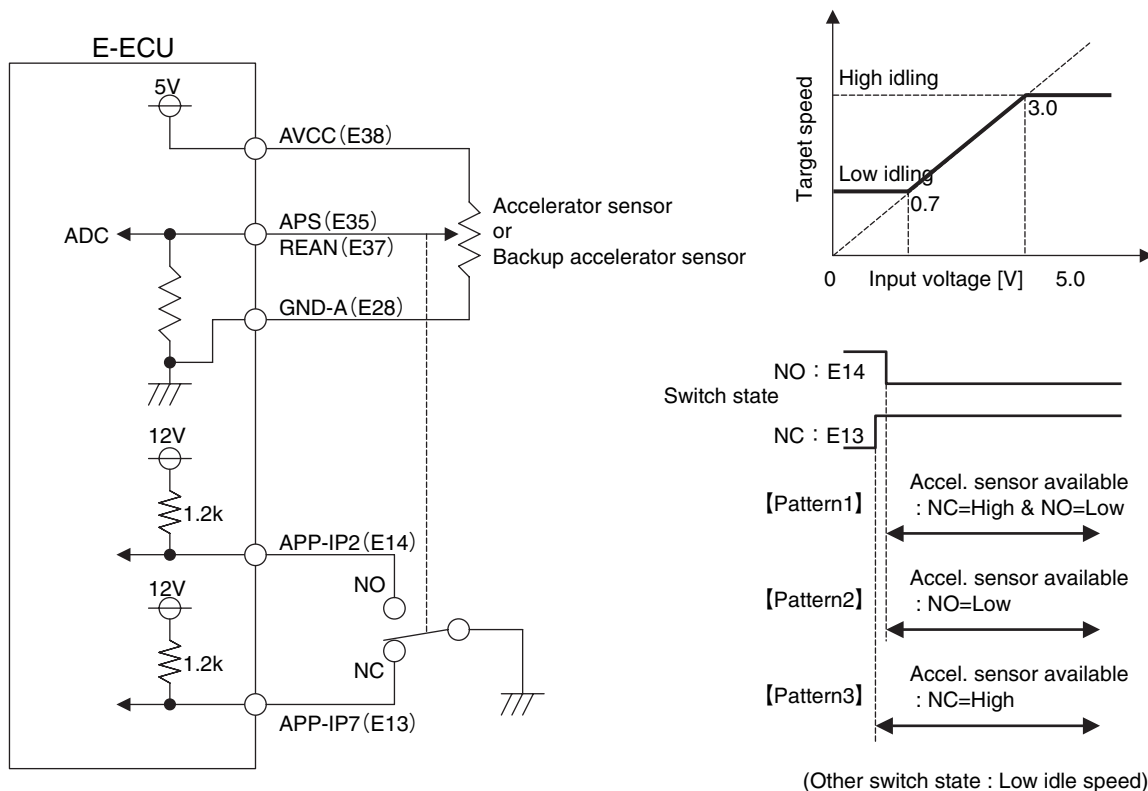
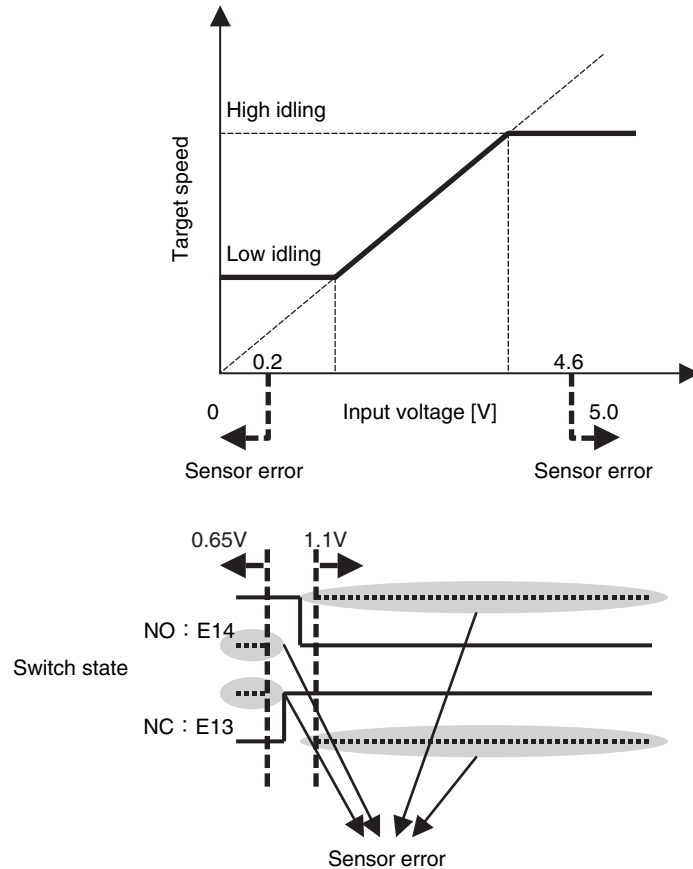

**Figure 2-33 Foot pedal operation**

**Figure 2-34** shows the foot pedal failure detection scheme. If the input voltage from the foot pedal is out of the range of 0.2 V to 4.6 V, the E-ECU detects a sensor failure.

If APP-IP2: NO goes high or APP-IP7: NC goes low while the input voltage is 1.1 V or higher, the E-ECU detects a sensor failure (depending on the status of the active switch when the flag is set to 3 or 4).

Moreover if APP-IP2: NO goes low or APP-IP7: NC goes high while the input voltage is 0.65 V or lower, the E-ECU also detects a sensor failure (depending on the status of the active switch when the flag is set to 3 or 4).



**Figure 2-34** Foot pedal failure detection

## Starting aid

Using an optional air heater relay allows the starting aid (air heater or glow plug) to be controlled as follows. The air heater relay permits the E-ECU to check for disconnection or short-circuit.

### 1. ON-glow control (standard feature)

When the key switch is moved to the "ON" position, the air heater relay is automatically energized for a duration that depends on the coolant temperature. The preheat lamp can be on during energization. (This feature is the same as provided by QHS controller 129457-77900. QGS controller 119650-77900 has a two-stage temperature control feature).

The preheat time for ON-glow control differs for an air heater and a glow plug used as the starting aid. See **Figure 2-35**.

### 2. Simultaneous energization (standard feature)

This feature allows energizing the air heater relay while energizing the starter when the key switch is in the START position, facilitating cold start. (This feature is the same as provided by QHS controller 129457-77900 and QGS controller 119650-77900).

When the voltage at the power supply terminal of the E-ECU decreases to 6.5 V, the air heater relay is de-energized to prevent the E-ECU from being reset due to "supply voltage low" (the E-ECU is reset when the supply voltage lowers to 6.0 V).

Energization of the air heater relay can be halted while the starter is energized.

### 3. After heating (optional feature)

This feature allows the air heater relay to be energized for 80 seconds after engine start or as long as the coolant temperature is lower than 10°C, thereby reducing the time required for self-extinguishing of blue and white smoke. (This feature is the same as provided by QHS controller 129457-77900 except for temperature and time settings. QGS controller 119650-77900 has no after glow feature). Åj

The after heating feature is disabled by default to avoid a heavy burden on the battery. Use this feature in due consideration to the battery charging/discharging cycle.

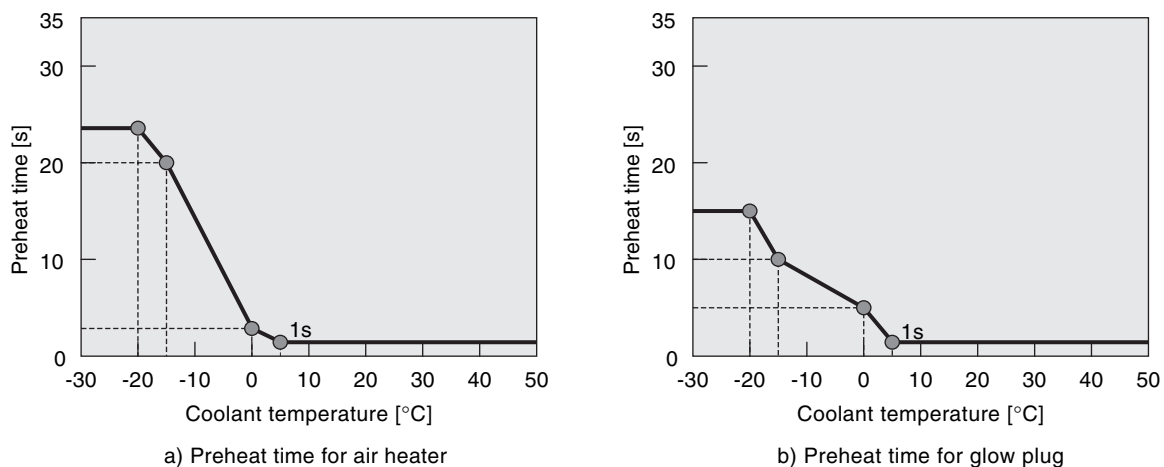

**Figure 2-35 Preheat time for ON-glow control**

## Starter motor start prevention

When the key switch is turned on, the Eco-governor performs rack self-diagnostics before starting the engine in order to ensure safety. The starter motor must therefore be prevented from starting until rack self-diagnostics is completed. Starter motor starting prevention can be implemented by connecting a starter relay to the E-ECU. See **Figure 2-36**.

In addition to rack self-diagnostics, the E-ECU has the following features:

### 1. Safety relay (standard feature)

This feature turns the starter off when the engine speed reaches  $675 \text{ min}^{-1}$ , and disables the starter to start until the engine speed decreases to  $325 \text{ min}^{-1}$  or less. (This feature is the same as provided by 119802-77200 when the pulley ratio is 2).

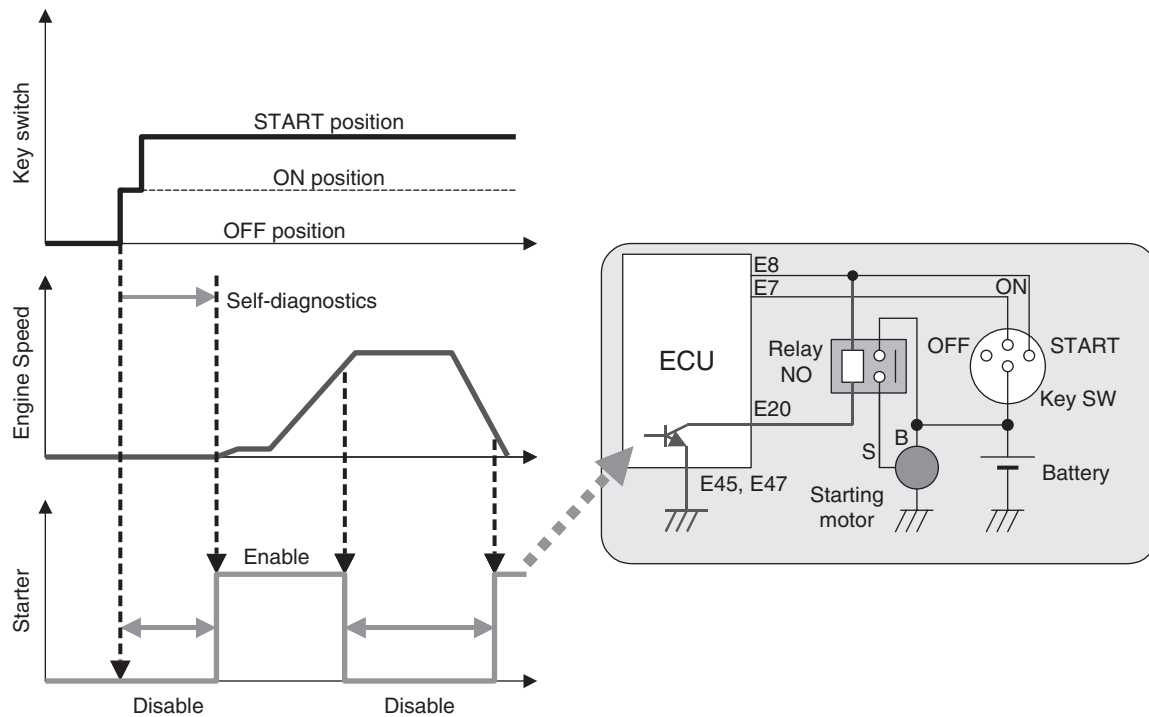

**Figure 2-36** Timing chart of stator motor start prevention

### 2. Starter disable (optional feature)

This feature turns off the starter when it is energized continuously for 30 seconds, and disables it to be energized for 30 seconds, thereby providing protection to the starter.

### 3. External switch control (optional feature)

This feature allows the starter to be disabled until an external switch (at APP-IP1 in common use for droop selection) turns on. See **Figure 2-37**. This can be used for creating a safety system where the starter cannot start unless a safety pedal is depressed.

The starter can be enabled via CAN communication in place of contact input at APP-IP1. The starter can also be enabled by the AND of the APP-IP1 contact input and the CAN communication input.

The conditions that enable the starter can be changed using map flags for setting E-ECU applications.

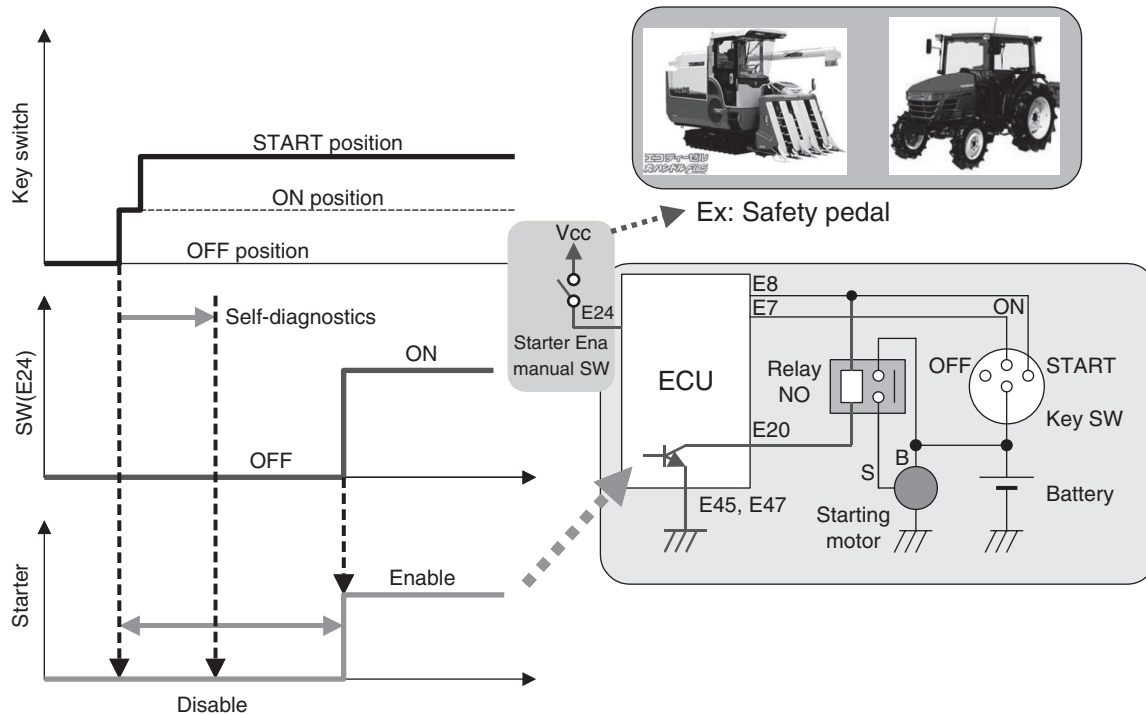

**Figure 2-37 External switch and starter disable/enable circuit**

Utilizing features 1 and 2 above permits establishing an auto start/stop system that can be operated through an external sequence. See **Figure 2-38** for details. In the figure, a machine start recognition signal (E8) is given from an external control device in place of the key switch.

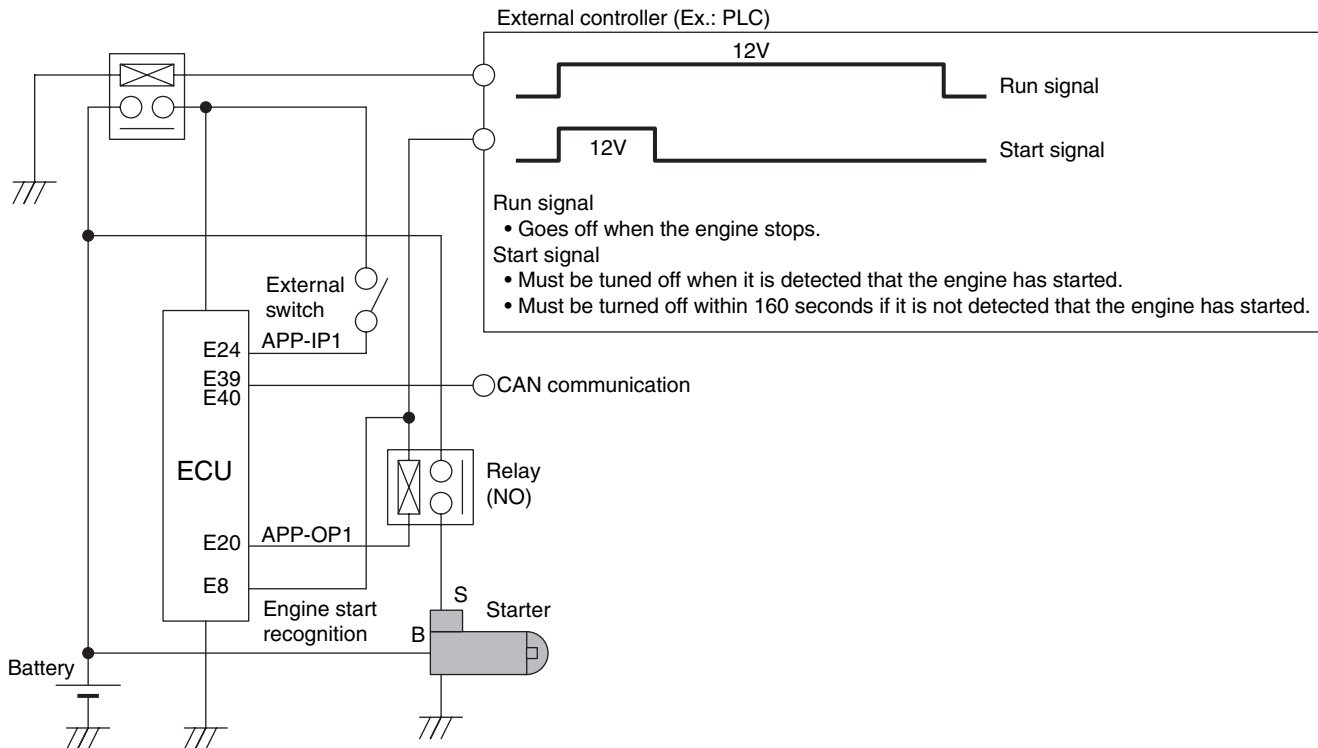

**Figure 2-38 Connection diagram of an auto start/stop system**

The engine run signal goes on at engine start and goes off at engine stop. If it is not detected that the engine has started, the start signal must be turned off within 160 seconds as a guideline. Otherwise, the starter tries to start the engine repeatedly in intervals of 30 seconds.

**Speed selection**

The Eco-governor has a speed selection feature that allows the engine speed to be changed with external switch inputs. The speed selection feature includes three modes: (1) Constant speed mode where the engine speed is kept constant, (2) Constant deceleration mode where the engine speed is reduced from a specified value with a constant deceleration, and (3) Auto deceleration mode where the engine speed is set to a specified value after a specified time has elapsed.

**Table 2-10** shows the relationship between the position of external switches and the engine speed in the three modes.

**Table 2-10 Engine speed and external switch position**

Map setting	External switches			Engine Speed
	Speed selection enable switch (E6)	Speed1 switch (E9)	Speed2 switch (E17)	
(1) Constant speed (Standard)	Disabled	-	-	Per accelerator command
	Enabled	OFF	OFF	1500 min <sup>-1*</sup> )
		OFF	ON	Low idling
		ON	OFF	1800 min <sup>-1*</sup> )
		ON	ON	High idling
(2) Constant deceleration (Optional)	Disabled	-	-	Per accelerator command
	Enabled	OFF	OFF	Deceleration 70% <sup>*)</sup>
		OFF	ON	Per accelerator command
		ON	OFF	Deceleration 85% <sup>*)</sup>
		ON	ON	Per accelerator command
(3) Auto deceleration (Optional)	OFF	-	-	Per accelerator command
	ON	OFF	OFF (delay: 4s <sup>*)</sup> )	Low idling
		OFF	ON	Per accelerator command
		ON	OFF (delay: 4s <sup>*)</sup> )	1800 min <sup>-1*</sup> )
		ON	ON	Per accelerator command

Values marked with an asterisk (\*) can be changed. (Optional)

# CONTROL SYSTEM

## (1) Constant speed mode

Figure 2-39 shows the connection diagram for constant speed mode.

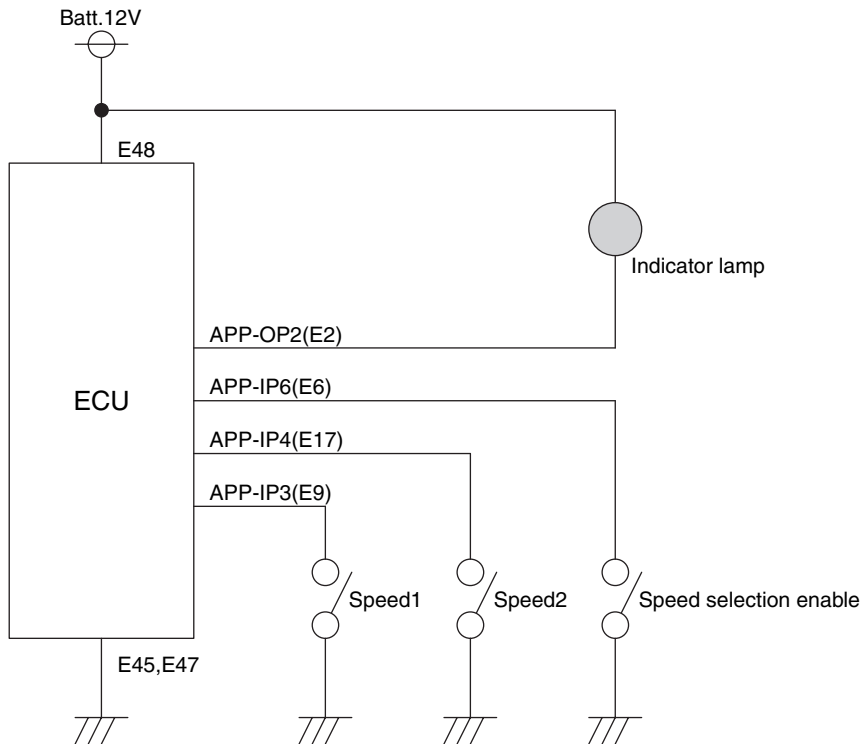

Figure 2-39 Connection diagram for constant speed mode

Figure 2-40 shows the operation timing for constant speed mode. The speed selection enable switch (E6) is available in two types: toggle and momentary.

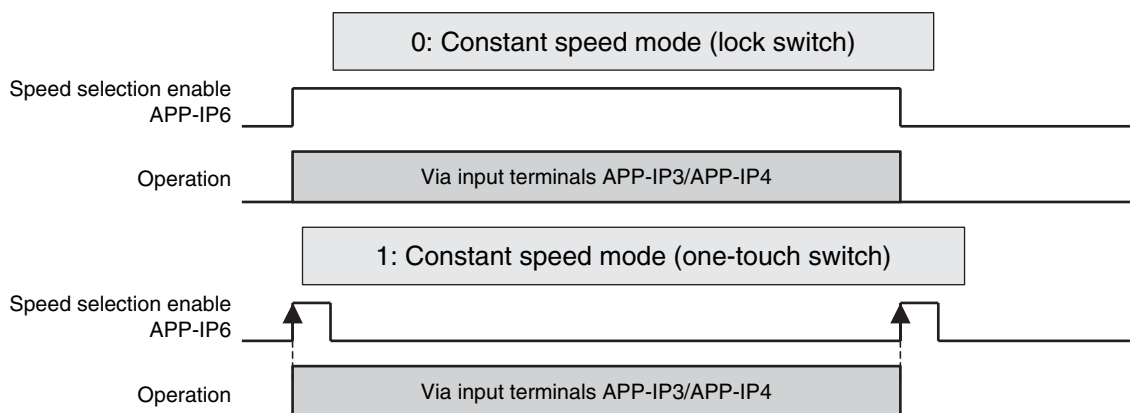

Figure 2-40 Operation timing for constant speed mode

(2) Constant deceleration mode

Figure 2-41 shows the connection diagram for constant deceleration mode.

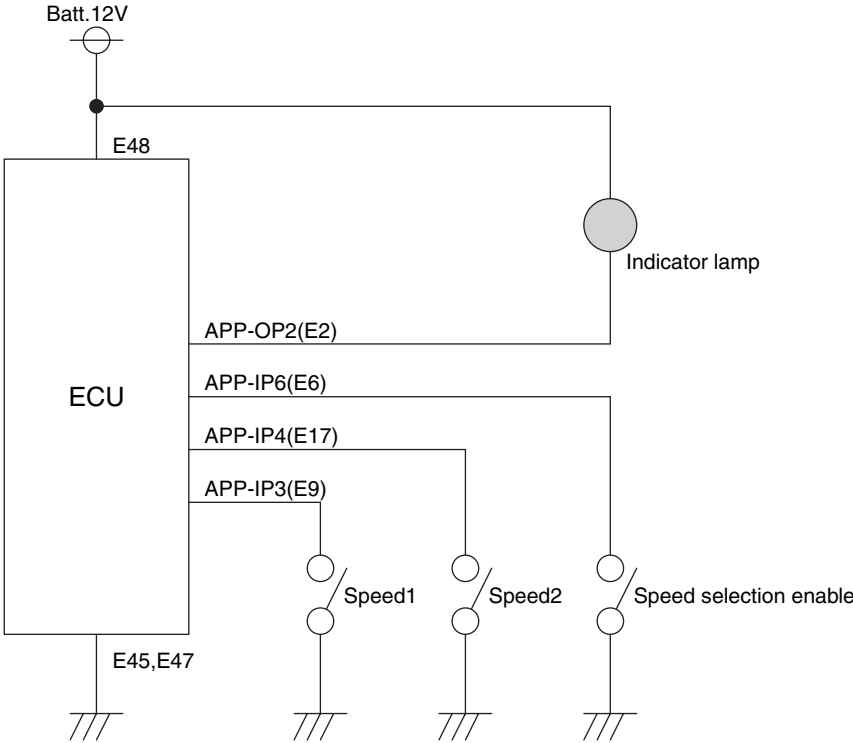

Figure 2-41 Connection diagram for constant deceleration mode

Figure 2-42 shows the operation timing for constant deceleration mode. The speed selection enable switch (E6) is available in two types: toggle and momentary.

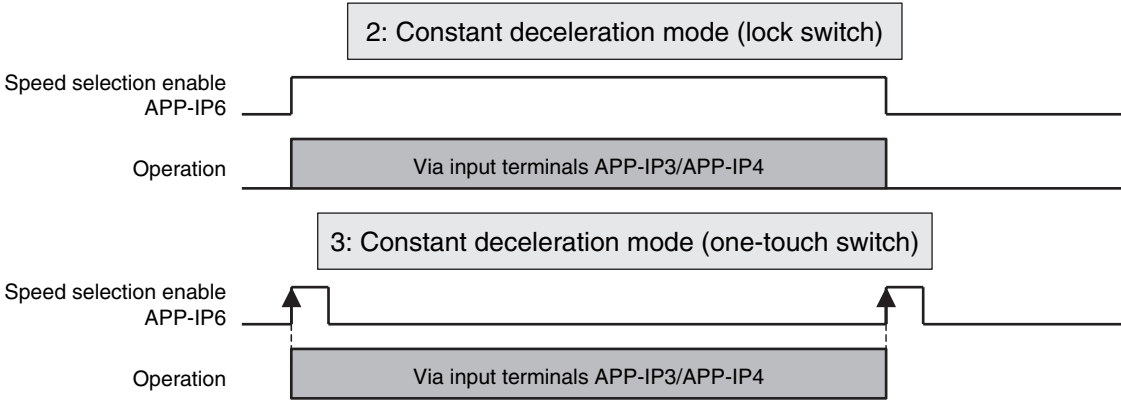
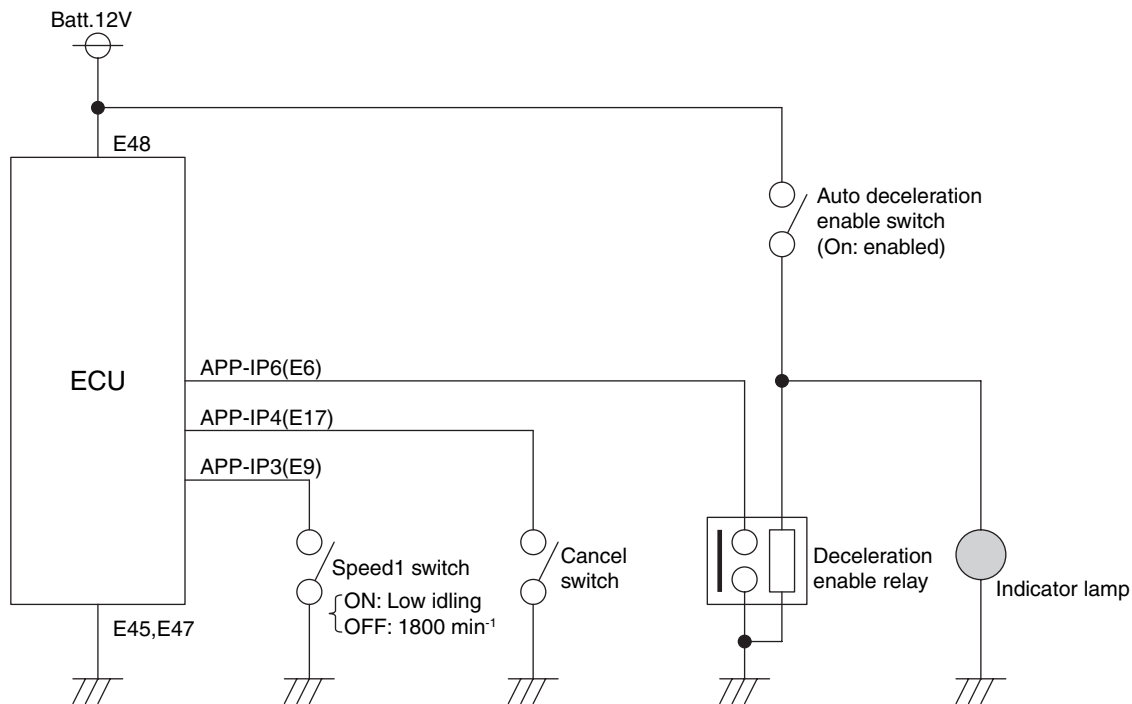

Figure 2-42 Operation timing for constant deceleration mode

# CONTROL SYSTEM

## (3) Auto deceleration mode

Figure 2-43 shows the connection diagram for auto deceleration mode.



**Figure 2-43** Connection diagram for auto deceleration mode

Figure 2-44 shows the operation timing for auto deceleration mode.

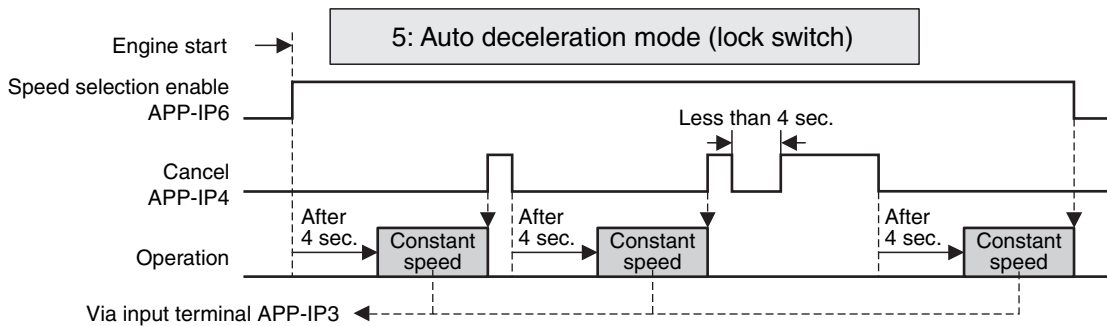

**Figure 2-44** Operation timing for auto deceleration mode

### Caution:

The type of the speed selection enable switch (toggle or momentary) is mapped. As a momentary switch involves the possibility of a sudden change in engine speed if the E-ECU is reset, it is recommended to use a toggle switch.

External switch input can be replaced with CAN communication input.

**Engine cutoff**

When the key switch is turned off and the rack actuator is shut off, the engine is cut off. (No stop solenoid is required).

The engine can also be cut off by turning on terminal SHUDNSW to which an engine stop switch has been connected. The engine stop switch is available in two types: NC (normally closed) and NO (normally open).

As the E-ECU usually assumes that the engine stop switch of NO type is used to stop the engine.

Furthermore the engine can be cut off by turning on the engine stop2 switch that connects to terminal APP-IP7 provided that APP-IP7 has been set for engine stop2. Such an engine stop switch can be utilized as a safety switch that stops the engine when the engine cover is opened, for example. The input signal to the engine stop2 switch can also be given through CAN communication instead of from terminal APP-IP7. By default, terminal APP-IP7 is set for Rmax 1.

**Table 2-11** shows the comparison of engine cutoff means and **Figure 2-45** shows a circuit example. The engine stop switch is available in two types: NC (normally closed) and NO (normally open).

A failure detected by the E-ECU may cause the engine to stop. See 6 "Engine/control failure detection" for details.

**Table 2-11 Comparison of engine cutoff means**

Engine stop input	switch			CAN input	Engine stop conditions			
	Connection	Contact	Momentary		Rackactuator relay	Rack	Starter	Recovery
SHUDNSW	High side	NC	OK	NG	OFF	Halt	Disabled	Turn Key off
APP-IP7	Low side	NO	OK	OK	OFF	Halt	Disabled	Turn Key off

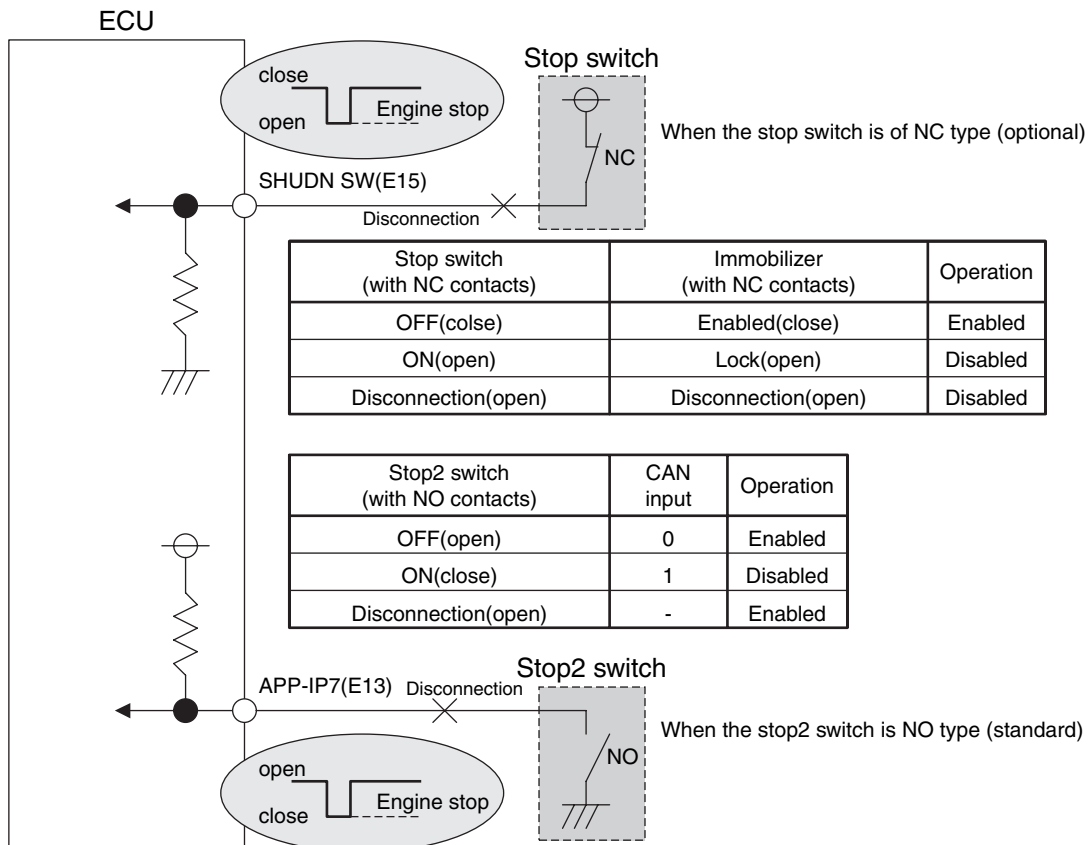

**Figure 2-45 Engine cutoff with external switch**

## Idling speed up

The feature allows the low idling speed to increase gradually until the coolant reaches a specified temperature, helping the engine warm up quickly. See the figure below. See **Figure 2-46**. By default, the "idling speed up" feature is disabled.

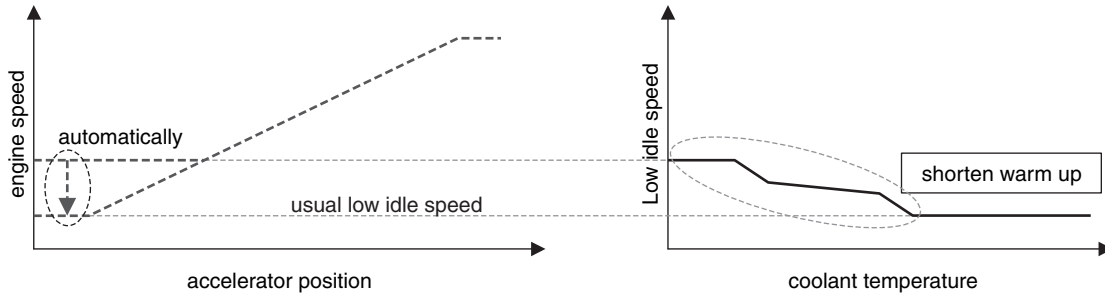

**Figure 2-46** Idling speed up in cold conditions

**Figure 2-47** shows the standard idling up settings and coolant temperatures. The settings can be changed. (Optional)

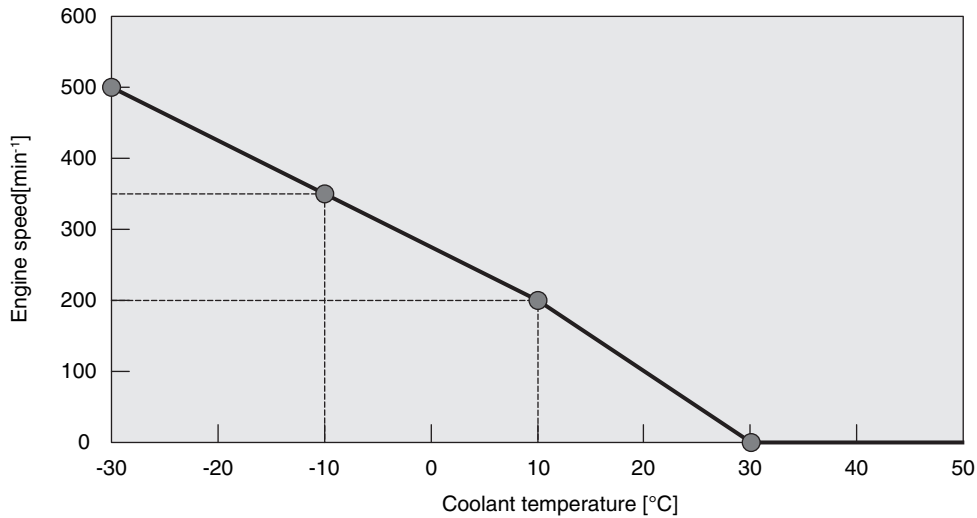

**Figure 2-47** Idling up settings

## Blue and white smoke suppression

The feature allows the high idling speed to be limited when the coolant is lower than a prescribed temperature, thus reducing the time required for vanishing the emission of blue and white smoke in cold start conditions. See **Figure 2-48**. By default, the "blue and white smoke suppression" feature is disabled.

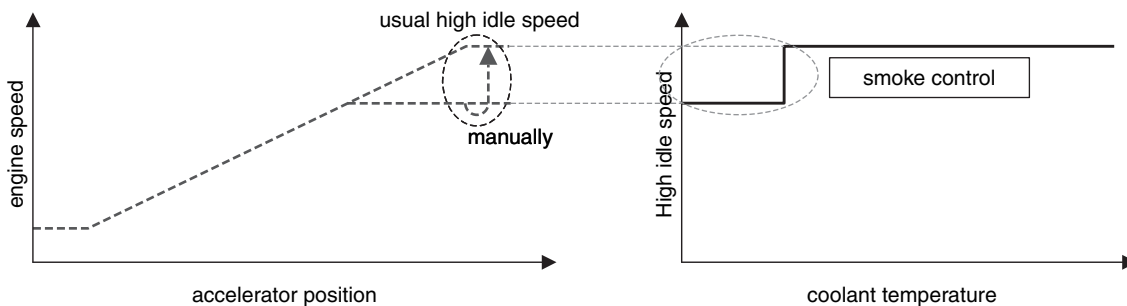

**Figure 2-48** High idling speed limitation in cold conditions

The blue and white smoke suppression feature is available as an option for engines with a rated rpm of 2300 min<sup>-1</sup> or higher. When this feature is enabled, the high idling speed at a coolant temperature of 5°C or lower decreases by approx. 100 - 200 min<sup>-1</sup>.

### Accelerator filter

The accelerator filter regulates the trade-off between acceleration/deceleration time and overshoot/undershoot during acceleration or deceleration. This feature is factory set appropriately, but a higher priority may have to be given to either the reduction of acceleration/deceleration time or the suppression of overshoot/undershoot depending on the engine applications.

**Figure 2-49** shows the effect of the accelerator filter. The accelerator filter delays reaching the engine target speed, thereby avoiding overshoot and undershoot while trading off the speed responsibility of the engine.

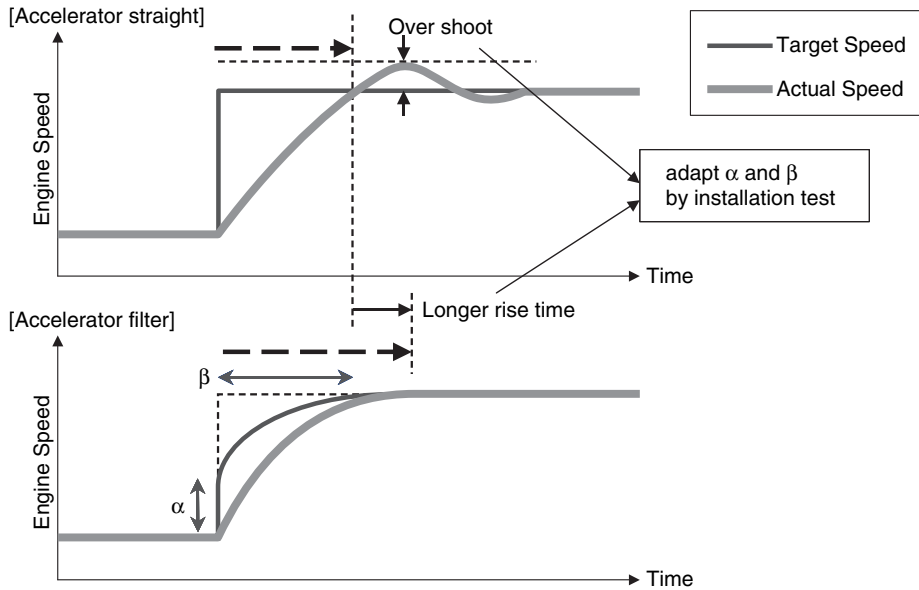
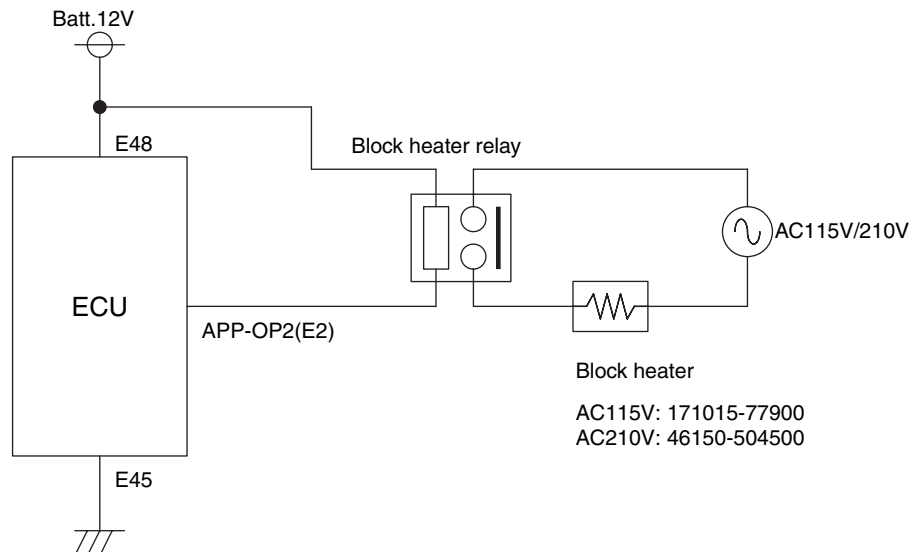

**Figure 2-49** Effect of the accelerator filter

### Block heater control

This feature allows the block heater to be turned on or off by an external coolant-temperature monitoring relay as long as the E-ECU power supply is on. By default, the block heater relay turns on when the coolant temperature decreases to 15°C, and turns off to disable the block heater when the coolant temperature increases to 50°C.

**Figure 2-50** shows a typical connection diagram for block heater control.



**Figure 2-50** Connection diagram for block heater control

# CONTROL SYSTEM

## Highland compensation (pending)

This feature allows the injection quantity to be controlled so that the emission of black smoke due to a low oxygen concentration is minimized in high-altitude places. By default, the highland compensation feature (pending) will be disabled.

## Engine failure detection

The E-ECU accepts the connection of engine failure detection sensors as shown in **Figure 2-51**. Actions to be taken depending on the status of sensors can be programmed. The sensor status can also be sent via CAN communication.

A failure lamp can be connected to each sensor. See **Figure 2-51**. Be sure to connect a lamp or load resistance (120Ω) to the pressure switch so that the contact current is 100 mA or higher.

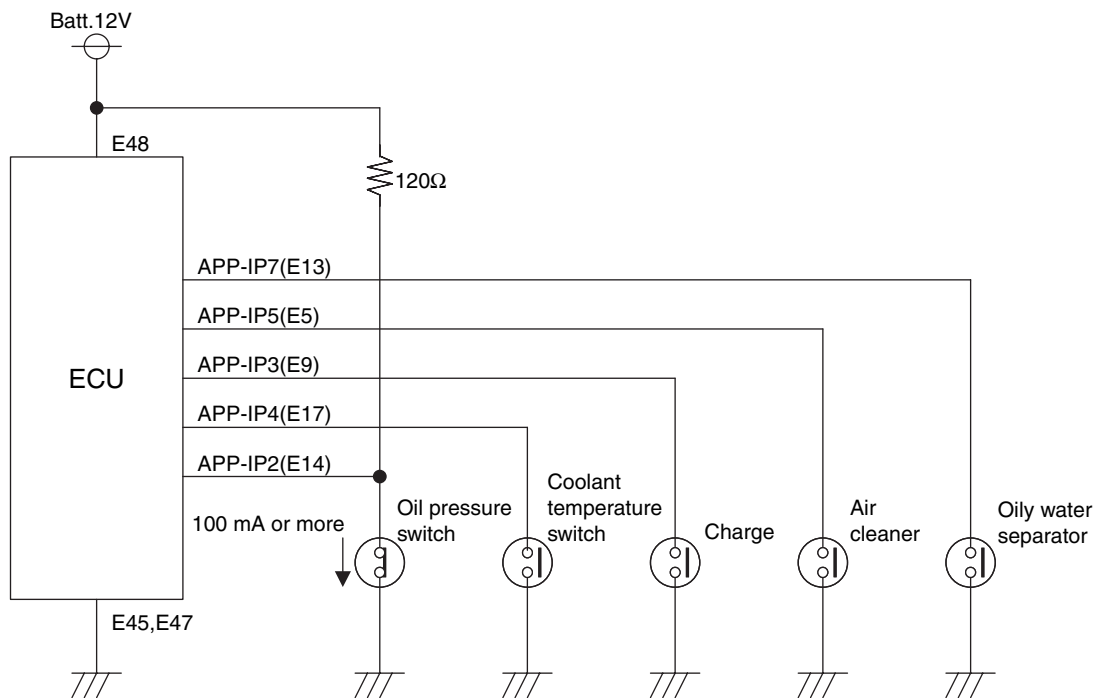

**Figure 2-51** Connection of sensors for engine failure detection

## Control failure detection

The E-ECU performs various self-diagnostics as shown in **Table 2-12**.

Diagnostic items are divided into "Always enable", "Default to enable" and "Default to disable" in the table.

**Table 2-12 Diagnostic list**

No.	Item	Failure detection conditions	Operation when failure occurs	Action/condition for recovery	Category	Number of flashes
1	Coolant temperature sensor failure	Sensor voltage is 4.8 V or more, or 0.2 V or less.	Engine runs with a coolant temperature of 30°C.	Correct failure.	Always enable	4
2	Accelerator sensor failure	Sensor voltage is 4.6 V or more, or 0.2 V or less.	[Without optional backup accelerator sensor] Engine runs at 1500 min <sup>-1</sup> . (Option can change) [With optional backup accelerator sensor] Select backup accelerator sensor: No limitation Backup accelerator sensor failure: Engine runs at 1500 min <sup>-1</sup> .(Option can change)	Correct failure.	Default to disable	5
3	Speed sensor failure	Engine start signal (E8) is on, but the engine speed is zero.	[With optional backup speed sensor] Backup speed sensor becomes active; speed is limited to 1800 min <sup>-1</sup> .(Option can change)	Turn key off.	Always enable	6
		Engine speed decreases by 480 min <sup>-1</sup> or more in 40 ms.	Backup speed sensor failed: Engine stops. [Without optional backup speed sensor] Engine stops.			
4	Rack position sensor failure	Correlation between rack actuator output and rack position exceeds threshold upper limit by 0.32 sec. or more.	Engine runs with limited output and speed. (Rack position control is inactive and speed control is active).	Turn key off.	Always enable	7
		Correlation between rack actuator output and rack position exceeds threshold lower limit by 0.16 sec. or more.				
5	Rack actuator failure	Rack actuator current is too high.	Engine stops.	Turn key off.	Always enable	8
		Rack actuator current is too low.				
		Engine accelerates with minimum rack actuator output.				
		Engine stalls while rack position sensor is failed.				
6	Overspeed	Idling engine speed exceeds high idling speed plus 600 min <sup>-1</sup> .	Engine stops.	Turn key off.	Always enable	9

# CONTROL SYSTEM

**Table 2-12 Diagnostic list**

No.	Item	Failure detection conditions	Operation when failure occurs	Action/condition for recovery	Category	Number of flashes
7	Backup speed sensor failure	Engine start signal (E8) is on, but the engine speed is zero.	Engine continues to run while main speed sensor is used. Backup speed sensor failed: Engine stops.	Turn key off.	Default to disable	1-1
		Engine speed decreases by 480 min <sup>-1</sup> or more in 40 ms.				
8	CAN communication failure	CAN communication packets cannot be received.	Last value is retained. Backup sensor becomes active.	Correct failure.	Default to enable	1-2
9	EGR valve failure	Low status is detected even through port is off.	Engine runs with limited output(92%) and speed(1800min <sup>-1</sup> ).	Turn key off.	Default to disable	1-3
		High status is detected even through port is on.				
10	CSD solenoid valve failure	High status is detected even through port is off.	Engine continues to run with port being off.	Turn key off.	Always enable	1-4
		Low status is detected even through port is on.				
11	Air heater relay failure	High status is detected even through port is off.	Engine runs with air heater relay being off.	Turn key off.	Default to enable	1-5
		Low status is detected even through port is on.				
12	Main relay failure	Power is not shut off even though main relay is off.	Engine runs normally.	Correct failure. Or turn key off.	Default to disable	1-6
13	Rack actuator relay failure	Low status is detected even through port is off.	Engine stops.	Turn key off.	Always enable	1-7
		High status is detected even through port is on.				
14	Backup accelerator sensor failure	Sensor voltage is 4.6 V or more, or 0.2 V or less.	Engine continues to run while main accelerator sensor is used. Main accelerator sensor failure: Engine runs at 1500 min <sup>-1</sup> . (Option can change)	Correct failure.	Default to enable	1-8
15	Atmospheric pressure sensor failure		Atmospheric pressure compensation is canceled.	Turn key off.	Default to enable	1-9
16	Oil pressure switch failure	Oil pressure switch fails to turn on when engine is off.	Engine runs normally. (Option can change)	Turn key off.	Default to enable	2-1
17	Charge switch failure	Charge switch fails to turn on when engine is off.	Engine runs normally.	Turn key off.	Default to enable	2-2
18	Power supply voltage abnormal	E-ECU supply voltage exceeds 10.0 V.	Engine runs normally.	Correct failure.	Always enable	2-3
		E-ECU supply voltage exceeds 16.0 V.				

**Table 2-12 Diagnostic list**

No.	Item	Failure detection conditions	Operation when failure occurs	Action/condition for recovery	Category	Number of flashes
19	Sensor 5V failure	Monitoring voltage is approx. 0 V.	Engine runs normally.	Turn key off.	Always enable	2-4
		Monitoring voltage is 4.5 V or less.				
		Monitoring voltage is 5.5 V or more.				
20	E-ECU overheat alarm	E-ECU temperature exceeds 105°C. Alarm is canceled when E-ECU temperature decreases to 100°C. (Option can change)	Engine runs normally.(Option can change)	Correct failure.	Default to enable	2.5
21	Oil pressure low	Oil pressure switch fails to turn off when engine is running.	Engine runs normally.(Option can change)	Correct failure.	Default to enable	3-1
22	Charge failure	Charge switch fails to turn off when engine is running.	Engine runs normally.	Turn key off.	Default to enable	3-2
23	Coolant temperature abnormal	Coolant temperature switch turns on.	Engine runs normally.(Option can change)	Turn key off.	Default to enable	3-3
24	Air cleaner blockage alarm	Air cleaner switch turns on.	Engine runs normally.(Option can change)	Turn key off.	Default to enable	3-4
25	Oily water separator alarm	Oily water separator switch turns on.	Engine runs normally.(Option can change)	Turn key off.	Default to enable	3-5
26	Coolant temperature high alarm	Coolant temperature is 115°C or higher. Alarm is canceled when Coolant temperature decreases to 110°C. (Option can change)	Engine runs normally.	Correct failure.	Default to enable	3-6
27	E-ECU failure [ROM error]	FlashROM suffers checksum error.	Engine stops.	Turn key off.	Always enable	4-1
28	E-ECU failure [EEPROM error]	Reading/Writing fails.	Engine runs normally.	Turn key off.	Always enable	4-1
		EEPROM suffers checksum error.				
29	E-ECU failure [Sub CPU failure]	E-ECU fails to communicate with sub CPU.	Engine runs normally.	Turn key off.	Always enable	4-1
30	E-ECU failure [Mapping error]	Map format is invalid.	Engine stops.	Turn key off.	Always enable	4-1
31	E-ECU failure [E-ECU temperature sensor failure]	Sensor voltage is 4.6 V or more, or 1.0 V or less.	Engine runs normally.	Correct failure.	Always enable	4-1

When detecting these failures, the E-ECU flashes the failure lamp to alert the operator to the occurrence of failure conditions. The failure lamp will illuminate for 2 sec. when the E-ECU is power on. This allows checking if the E-ECU is supplied with power normally. (The failure lamp is an essential means for checking or diagnosing the E-ECU).

## CONTROL SYSTEM

Flashing patterns of the failure lamp are shown in **Figure 2-52**. When accelerator sensor failure (flashing 5 time) and EGR valve failure (flashing 1 - 3 times) occur, the failure lamp flashes as shown in **Figure 2-52**. When two or more failures have occurred simultaneously, the failure lamp indicates all the failures in order of increasing number of flashes cyclically.

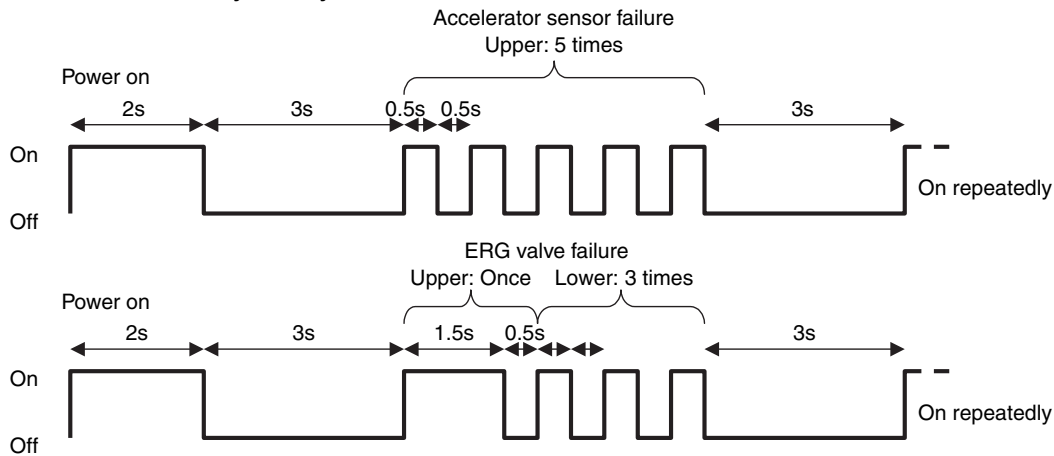

**Figure 2-52 Flashing patterns of the failure lamp**

Connecting the Yanmar genuine service tool to the E-ECU as shown in **Figure 2-53** allows status monitoring or diagnostic testing as well as the indication of detailed failure information, failure log and freeze frame data.

Failure log indications can include time stamps. Table 13 lists attributes available for time stamps.

**Table 2-13 Attributes of time stamps**

Flag	Attribute
0 (standard)	Accumulated engine run time
1	Accumulated E-ECU energization time
2	CAN reception time

See the service tool manual or troubleshooting chart for details.

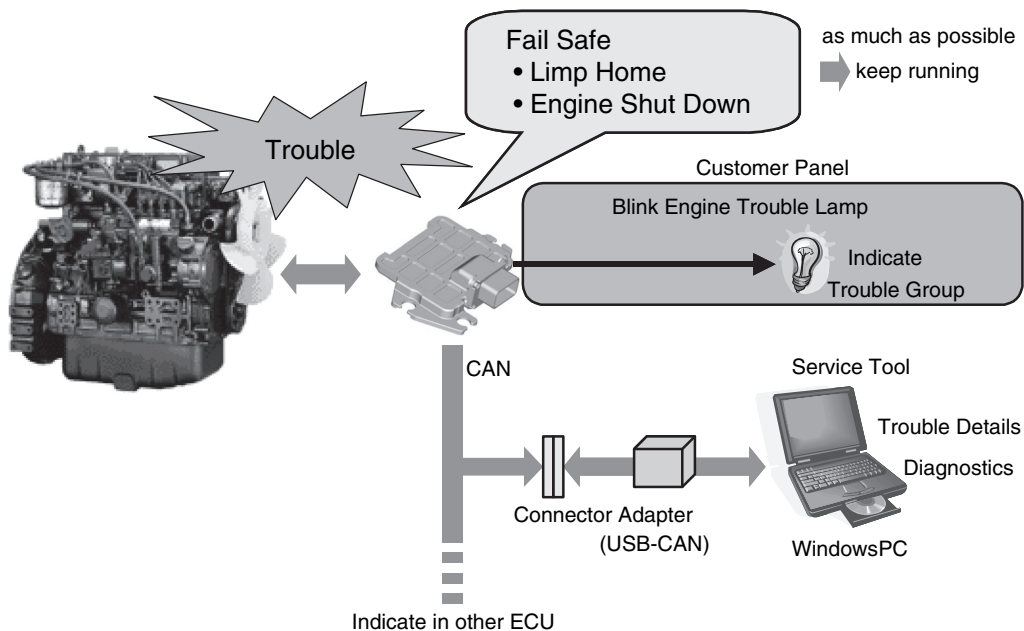

**Figure 2-53 Connection of the service tool for diagnostic**

**CAN communication**

The E-ECU is equipped with a CAN communication port that can be used to communicate with the service tool. The physical layer for CAN communication conforms to ISO 11898 Ver2.0B and uses 29-bit CAN arbitration ID. Baud rates of 250 kbps and 500 kbps (default) are available.

The E-ECU supports communication protocols conforming to ISO 15765 and KWP 2000 for service tool and ASE J1939 for inter-E-ECU communication.

The inter-E-ECU CAN communication feature is optional.

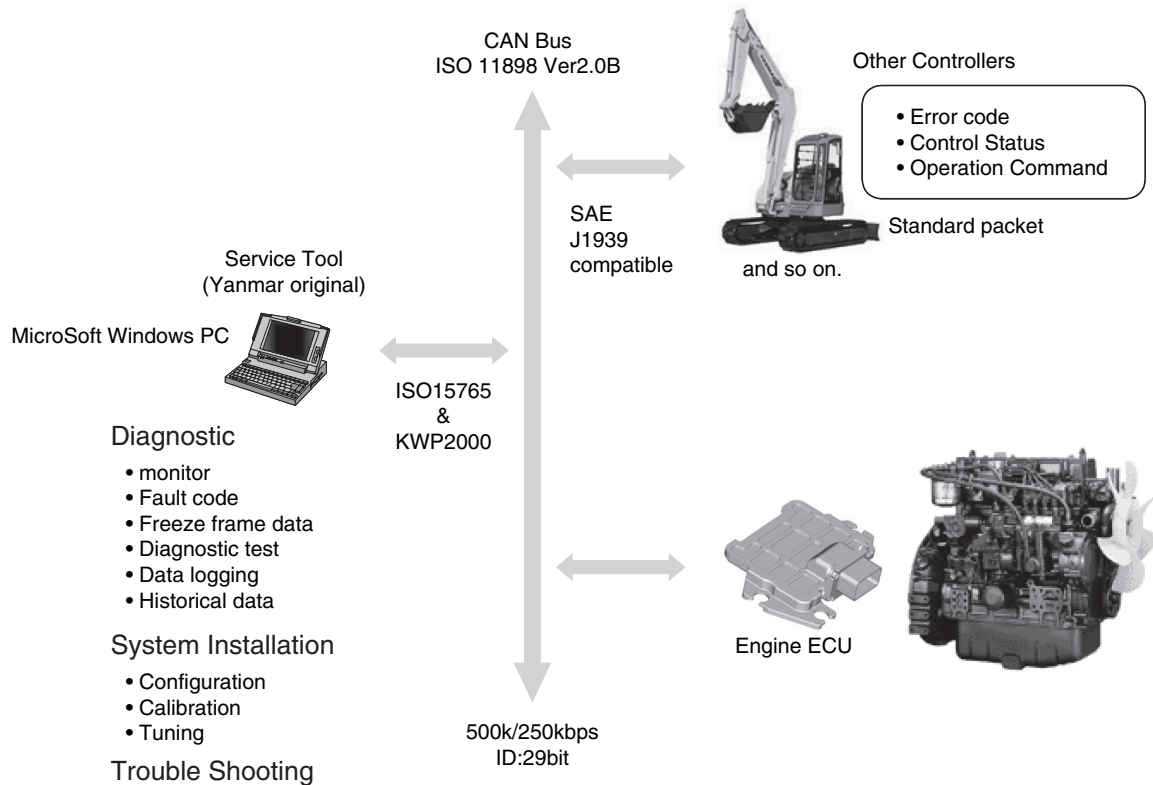

**Figure 2-54 Outline of CAN communication**

## CONTROL SYSTEM

### Terminal assignment

Each of the E-ECU terminals listed in **Table 2-14** is assigned multiple functions. The active function for each terminal can be changed by mapping.

By default, function 1 is enabled. Contact Yanmar for setting change.

**Table 2-14 E-ECU terminals assigned multiple functions**

Terminal No.	Terminal name	Function 1 (default)	Function 2	Function 3	Function 4
E24	APP-IP1	Droop selection	Starter enable	-	-
E14	APP-IP2	Rmax 2	Oil pressure switch	Speed up	Foot pedal NO switch
E9	APP-IP3	Speed 1	Charge alarm	-	-
E17	APP-IP4	Speed 2	Coolant temperature switch	-	-
E5	APP-IP5	Reverse droop	Air cleaner	Machine (up)	Pulse accelerator
E6	APP-IP6	Speed selection enable	Oily water separator	Machine (down)	-
E13	APP-IP7	Rmax 1	Stop 2 switch	-	Foot pedal NC switch
E20	APP-OP1	Starter relay	Middle-speed lamp	-	-
E2	APP-OP2	Eco-mode lamp	Block heater relay	Speed change indication lamp	Coolant temperature alarm lamp

Contact input terminal switches are available in two types: NC (normally closed) and NO (normally open).

**Table 2-15** lists contact input terminals for which a NO or NC switch can be selected.

**Table 2-15 Contact input terminal switches available in NC and CO types**

Terminal No.	Terminal name	Default function	Default input logic
E24	APP-IP1	Droop selection	NC
E14	APP-IP2	Rmax 2	NO
E9	APP-IP3	Speed 1	NO
E17	APP-IP4	Speed 2	NO
E5	APP-IP5	Reverse droop	NO
E6	APP-IP6	Speed selection enable	NO
E13	APP-IP7	Rmax 1	NO
E15	SHUDNSW	Engine stop	NO

**Table 2-16** lists E-ECU terminals whose functions must be mapped depending on whether or not the specific devices are connected to the terminals.

**Table 2-16 E-ECU terminals to be assigned a function**

Terminal No.	Terminal name	Device connected	Setting
E35	APS	Accelerator sensor	0: Non 1: Analog sensor (default) 2: Foot pedal + APP-IP2/IP7 switches 3: Foot pedal + APP-IP2 switch 4: Foot pedal + APP-IP7 switch(See "Accelerator sensor" for details).
E10	REN RPM	Backup speed sensor	0: Non 1: Backup speed sensor (default)
E44	AIRHT-RLY	Starting aid relay	0: Starting aid relay failure detection disabled (default) 1: Starting aid relay failure detection enabled
E37	REAN	Backup analog	0: No accelerator sensor 1: Analog sensor (default) 2: Foot pedal + APP-IP2/IP7 switches 3: Foot pedal + APP-IP2 switch 4: Foot pedal + APP-IP7 switch 5: Atmosphere pressure sensor (See "Accelerator sensor" and "Highland compensation" for details).
E16	TFO	Fuel temperature sensor	0: Non (default) 1: High-accuracy coolant temperature sensor

E16 can also be used as a backup coolant temperature sensor input. When terminal TFO is assigned as a coolant temperature sensor input as shown in **Table 2-17**, TFO (E16) must be flagged to 1. This terminal is reserved for developing a high-accuracy sensor.

**Table 2-17 Selection of the terminal for coolant temperature input**

Flag	Input terminal	Sensor to be used
Coolant temperature sensor selection	0: TW (E25) (default)	Conventional type (119254-44910)
	1: TFO (E16)	High-accuracy type (pending)

## CONTROL SYSTEM

### Operational limitations in failure situations

Operational limitations are applied to the engine when alarms or failures shown in **Table 2-19** occur. These limitations can be changed depending on properties of the machine to which the engine is installed.

**Table 2-18** shows mapping flags to be used for limiting the engine operation.

**Table 2-18 Operational limitations and map settings**

Map setting	Operational limitation	
	Speed limit	Output limit
6	Engine stop	
5	1800 min <sup>-1</sup>	92%
4	1500 min <sup>-1</sup>	92%
3	No limit	92%
2	1800 min <sup>-1</sup>	No limit
1	1500 min <sup>-1</sup>	No limit
0	No limit	No limit

**Table 2-19** shows alarms and failures at which operational limitations are applied to the engine, and flags for the limitations.

**Table 2-19 Default flag setting for operational limitations**

No. *2	Alarm/failure	Default flag
26	Coolant temperature alarm	0
2	Accelerator sensor failure *1	1
3	Backup speed sensor activation	2
9	EGR valve failure	5
21	Oil pressure low alarm	0
23	Coolant temperature alarm	0
24	Air cleaner blockage alarm	0
25	Oily water separator alarm	0
20	E-ECU overheat alarm	0

\*1 This flag setting is applied when an accelerator sensor failure is detected before the engine starts. When an accelerator sensor failure is detected while the engine is running, a value immediately before the failure is held.

\*2 These numbers are those used in **Table 2-12**.

Alarm/failure detection conditions depend on the setting of the flags shown in **Table 2-20**.

**Table 2-20 Alarm/failure detection condition setting flags**

<b>No.</b>	<b>Alarm/failure</b>	<b>Detection condition setting flag</b>
26	Coolant temperature high alarm	Coolant temperature alarm setting flag
2	Accelerator sensor failure	APS terminal function assignment flag
3	Backup speed sensor activation	REN RPM terminal function assignment flag
8	CAN communication failure	Application setting flag
9	EGR valve failure	EGR valve setting flag
11	Air heater relay failure	Starting aid relay failure detection setting flag
14	Backup accelerator sensor failure	REAN terminal function assignment flag
15	Atmospheric pressure sensor failure	
16	Oil pressure switch failure	APP-IP2 terminal function assignment flag
17	Charge switch failure	APP-IP3 terminal function assignment flag
21	Oil pressure low	APP-IP2 terminal function assignment flag
22	Charge failure	APP-IP3 terminal function assignment flag
23	Coolant temperature abnormal	APP-IP4 terminal function assignment flag
24	Air cleaner blockage alarm	APP-IP5 terminal function assignment flag
25	Oily water separator alarm	APP-IP6 terminal function assignment flag
20	E-ECU overheat alarm	E-ECU overheat alarm setting flag

## FUEL INJECTION PUMP

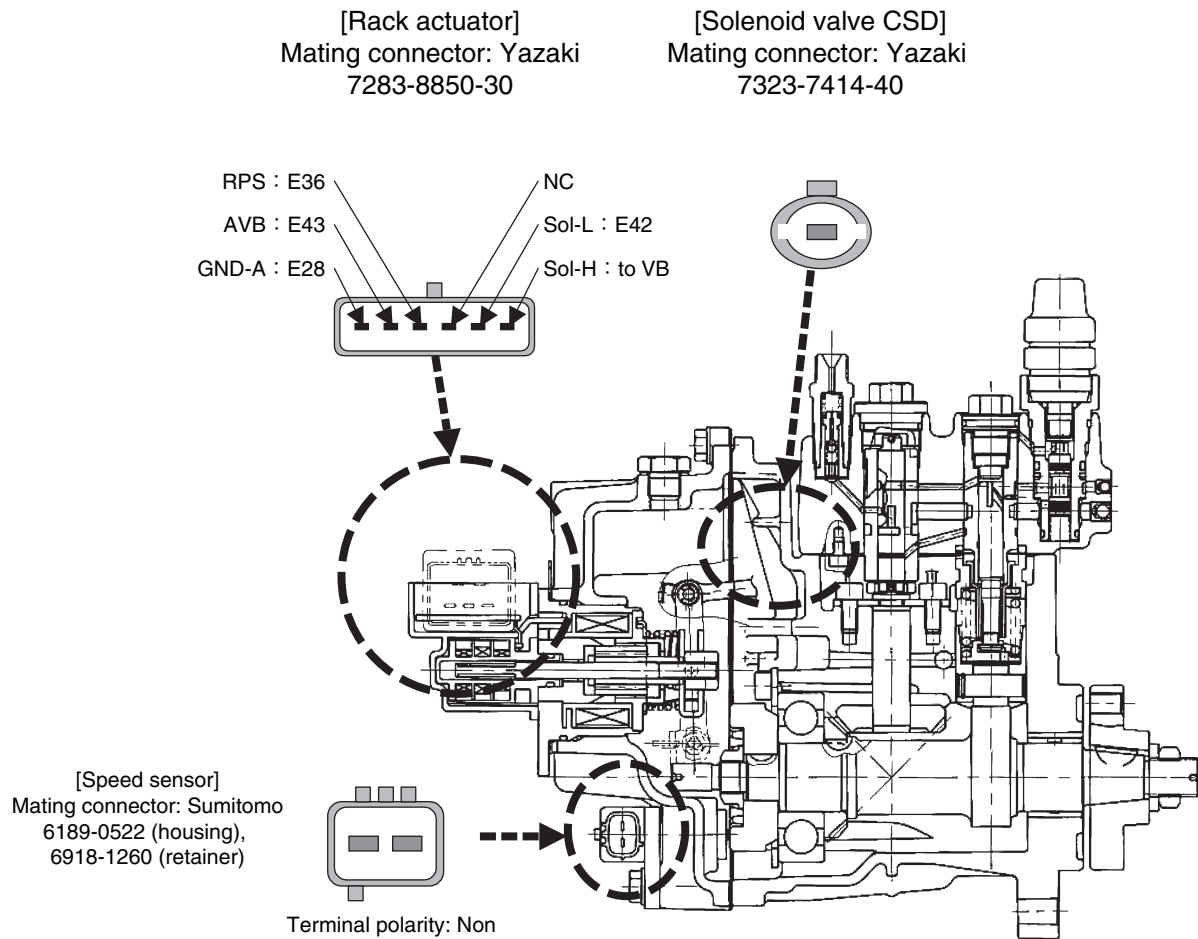

**Figure 2-55** Connectors applicable to the fuel injection pump

EGR VALVE

Mating connector:  
Sumitomo 6195-0021 or equivalent

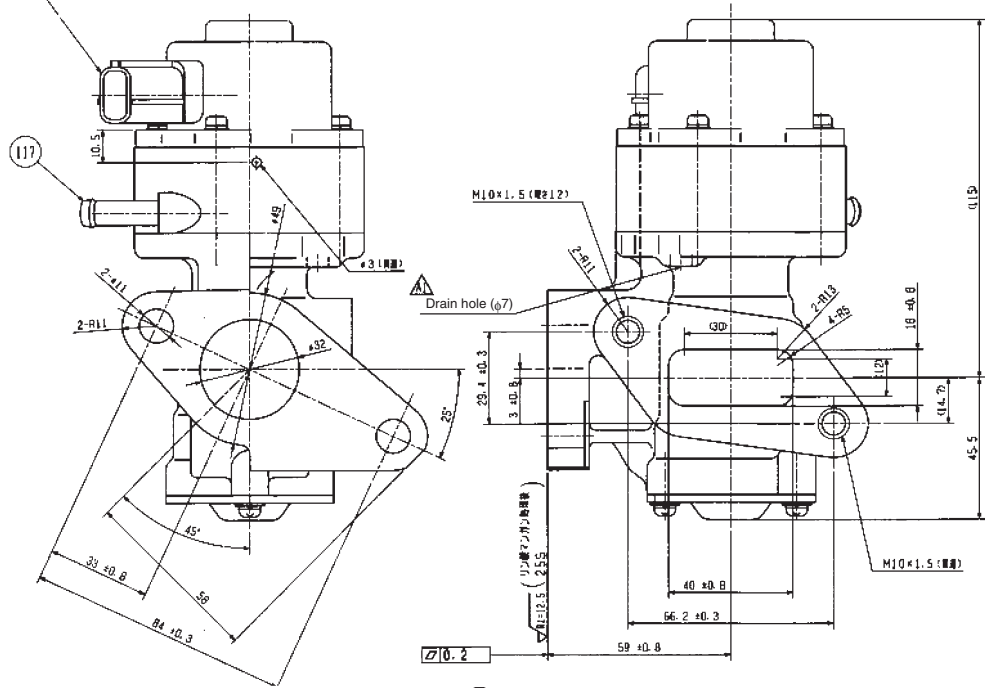

Connector pin arrangement

Mating connector:  
Sumitomo  
6195-0021 or equivalent

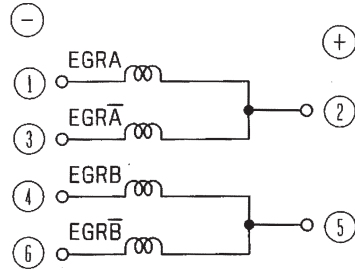
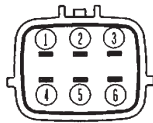
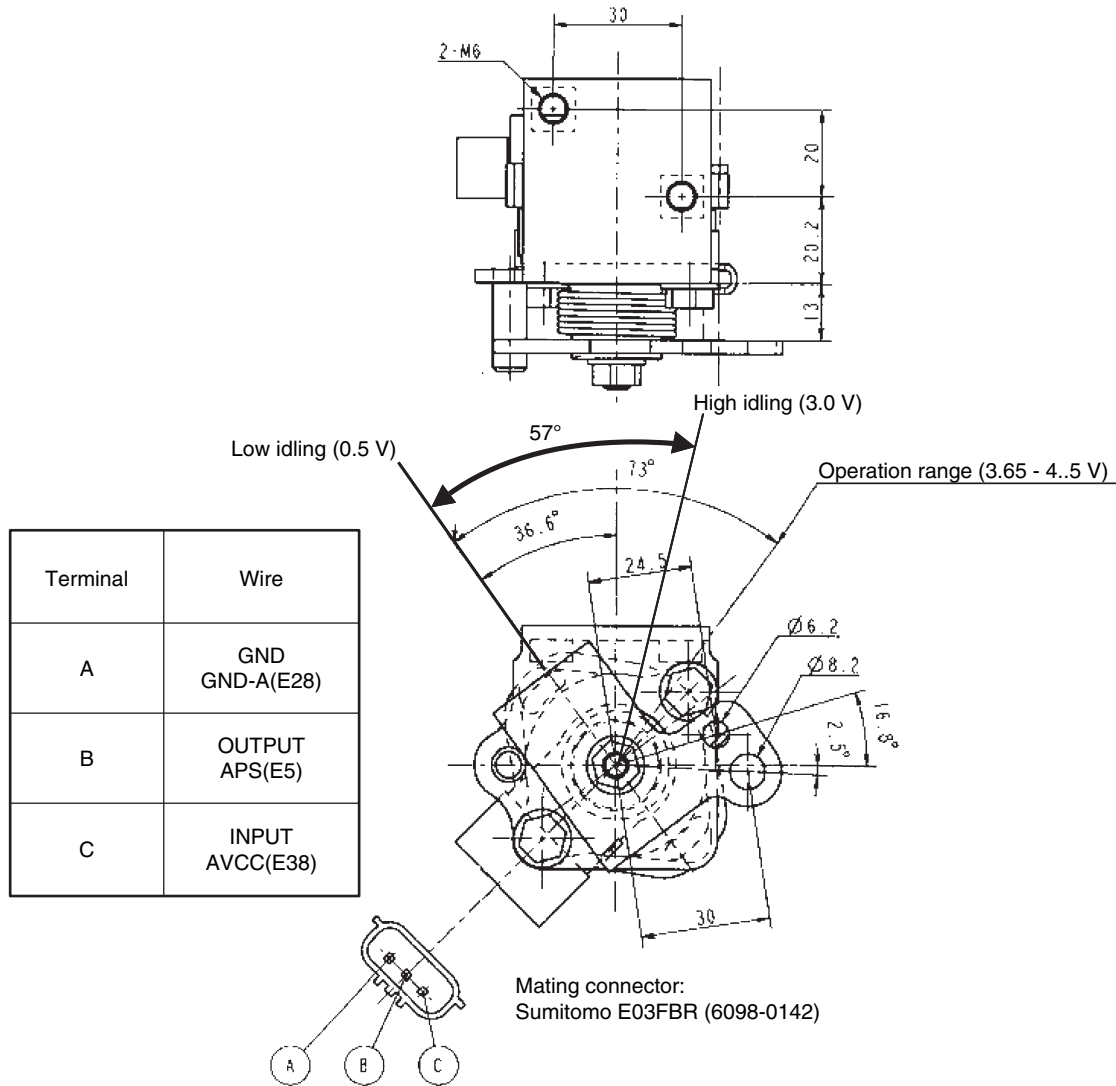

Figure 2-56 EGR valve outline

## ACCELERATOR SENSOR

The Eco-governor has no governor lever unlike a mechanical governor and requires an accelerator sensor to set the engine speed. Use a Yanmar standard accelerator sensor (see **Figure 2-57**) or equivalent. For general requirements of the accelerator sensor, see **Figure 2-2**, **Table 2-6**, "Accelerator input" and "Accelerator input selection".

Constant speed engines for generators may require no accelerator sensor. Contact Yanmar for details.



**Figure 2-57 Yanmar standard accelerator sensor (129938-77800)**

**Installation requirements of the Yanmar standard accelerator sensor:**

1. To protect against water and corrosion
  - Ensure no water is trapped inside the sensor axis or connector of the sensor.
  - Install the sensor in such an area that is not subject to steam or high-pressure water for cleaning.
  - Do not strain the harness. Doing so may damage waterproof seals, causing water to intrude into the harness.
2. To protect against vibrations
 

To prevent abrasion or deterioration of potentiometer resistance elements and disconnection of the harness, observe the following:

  - Install the sensor in such an area that is not subject to vibration of more than 2.4 Grms (5 to 1000 Hz in all directions).
  - Install the sensor so that no resonance is produced.
  - Install the sensor so that the sensor lever arm does not suffer vibration due to vibrations of the accelerator lever or wire cable. (Secure the accelerator lever and wire cable to the same member, for example). Ensure the fluctuation in output voltage of the accelerator sensor due to vibrations falls within a range of 1.6 mVp-p or less.
3. To protect against noise
  - Ensure the cable length between the E-ECU and the accelerator sensor does not exceed 5 m.
  - Do not lay the cable near noise sources such as large power devices. If it is inevitable to install the cable near noise sources, use a twisted or shielded cable.
  - Ensure the fluctuation in output voltage falls within a range of 50 mVp-p or less.
4. Others
  - Do not use sensors that have suffered drop impact or visible damage.

Rated voltage	5 Vdc±0.01V
Part Number	129938-77800
Total resistance (sensor alone)	5 ± 1.5kΩ
Working temperature range (sensor alone)	-30°C ~ 110°C
Storage temperature range (sensor alone)	-40°C ~ 130°C

## MAIN RELAY

The main relay provides power to the E-ECU, rack actuator, EGR valve etc. It contains a diode that prevents contact operation in case of reverse connection of the excitation coil. See **Figure 2-4** for electrical connection of the main relay.

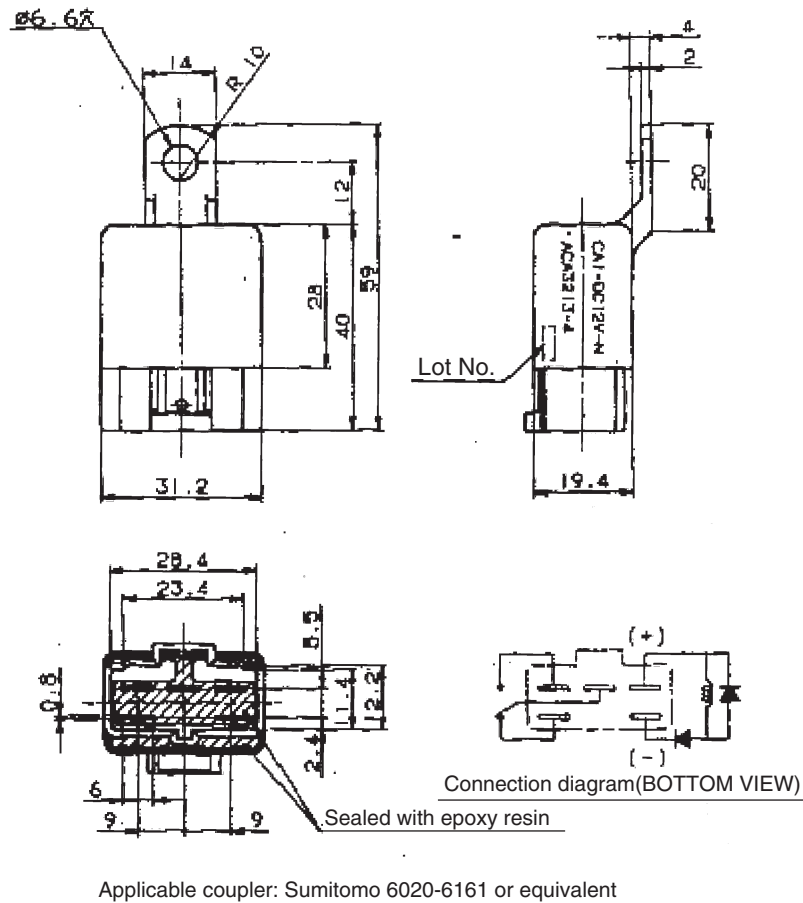

**Figure 2-58 CA relay**

Part Number	198461-52950
Coil rated voltage	12 Vdc
Rated excitation current	150 mA
Contact type	c-contact
Contact rated voltage	12 Vdc
Contact rated current	20 A, continuous / 100 A for 0.1 second

## RACK ACTUATOR RELAY

The rack actuator relay provides power to the rack actuator. The standard rack actuator relay is the same as the main relay. It also contains a diode that prevents contact operation in case of reverse connection of the excitation coil. But this diode is not necessarily required for the rack actuator relay. See **Figure 2-4** for electrical connection of the rack actuator relay.



Part Number	129927-77920
Coil rated voltage	12 Vdc
Rated excitation current	117 mA
Contact type	a-contact
Contact rated voltage	12 Vdc
Contact rated current	83 A for 200 seconds

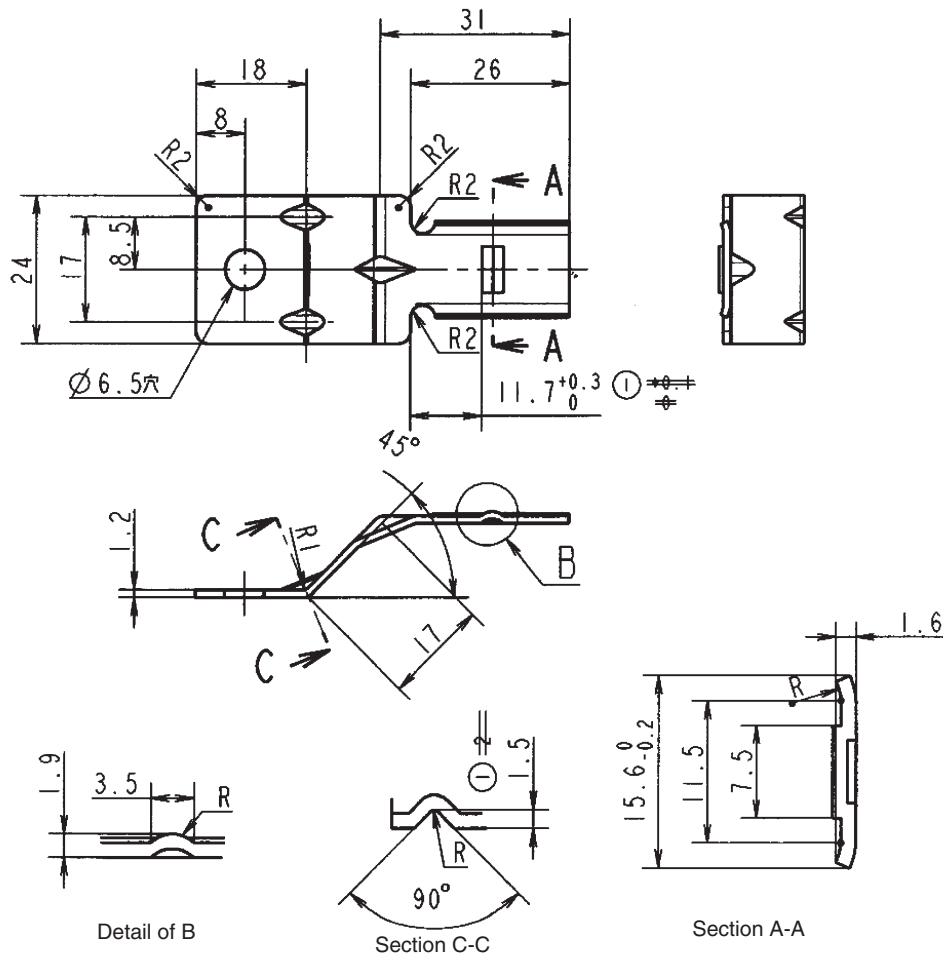
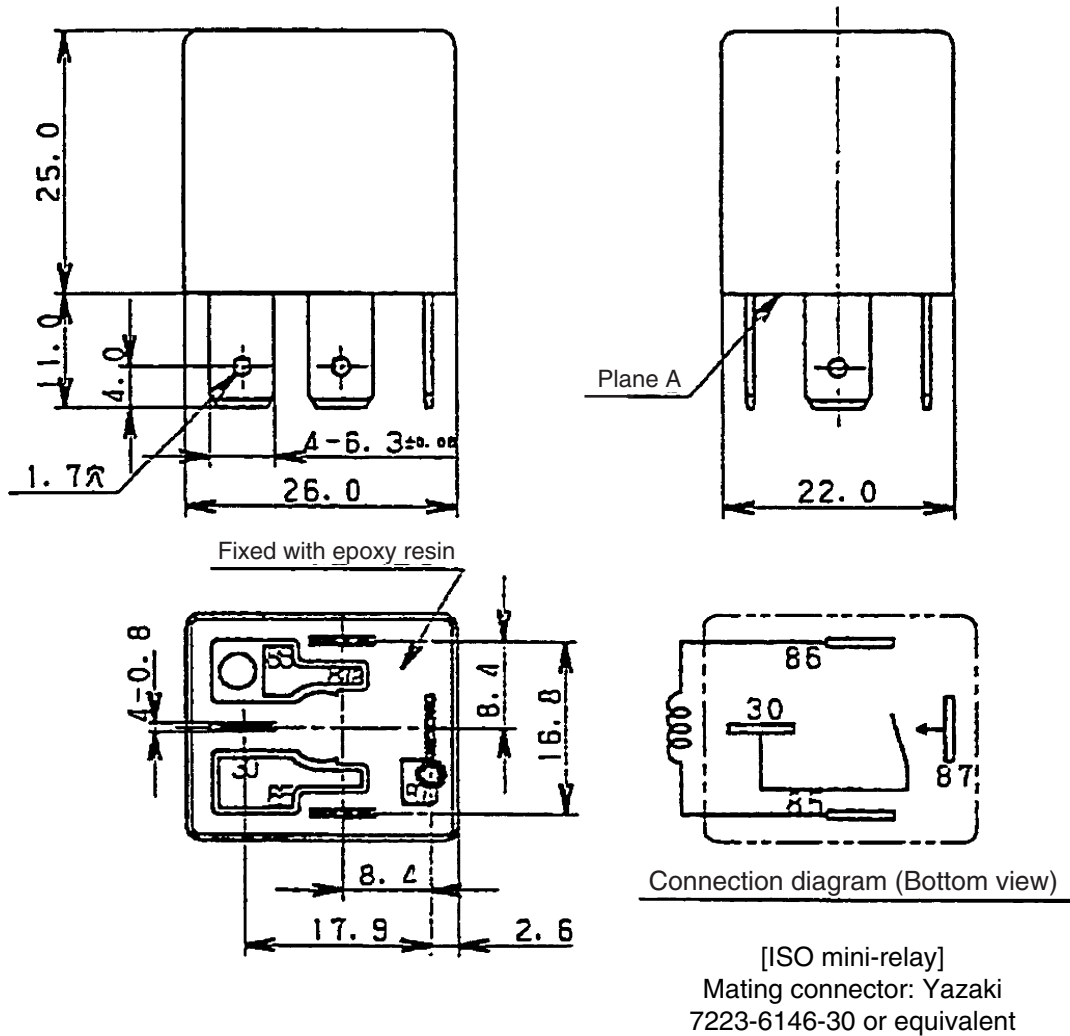

**Figure 2-60 Bracket for ISO relay (129927-77910)**

## STARTING AID RELAY

The starting aid relay controls power to the air heater or glow plug. See **Figure 2-4** for electrical connection of the starting aid relay. Three types of starting aid relays are available depending on the load capacity.

### For 400 W air heater (glow plug)



**Figure 2-61 ISO relay (40 A)**

Part Number	129927-77930
Coil rated voltage	12 Vdc
Rated excitation current	117 mA
Contact type	a-contact
Contact rated voltage	12 Vdc
Contact rated current	40A, continuous

As ISO relays have no bracket, a metal bracket compatible with the mating connector (Yazaki 7223-6146-30) is available. See **Figure 2-60**.



## COOLANT TEMPERATURE SENSORS

The coolant temperature sensor comprises a thermister and provides control to the Eco-governor.

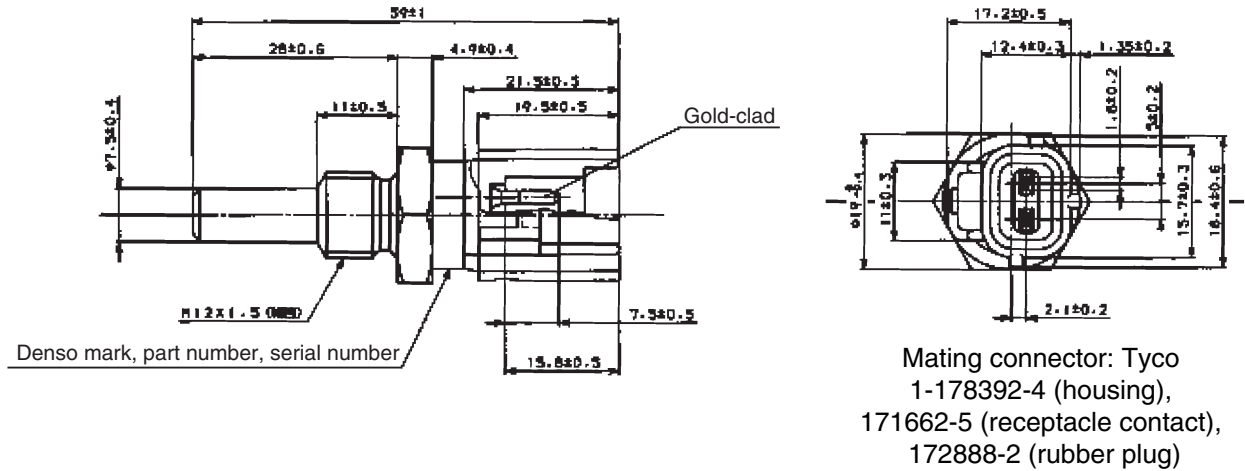

**Figure 2-63** Coolant temperature sensor (119254-44910)



# Appendix Standard harness (1)

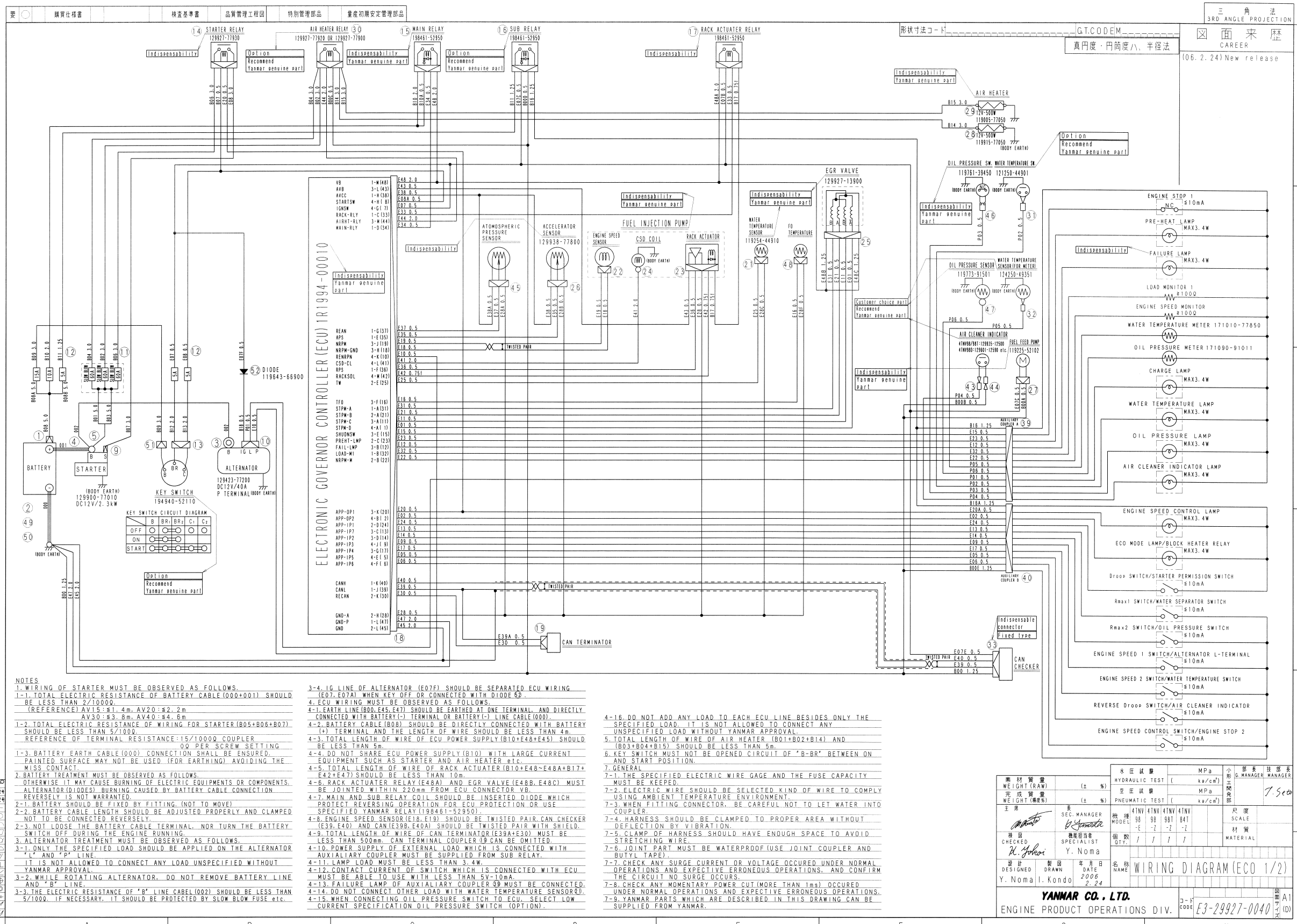

素材質量 WEIGHT(RAW) (±%) 完成質量 WEIGHT(組立後) (±%) 主務 DESIGNED CHECKED Y. Noma I. Kondo 2006 2.24	水圧試験 HYDRAULIC TEST (MPa) 空気試験 PNEUMATIC TEST (MPa) 機軸 MODEL: 98 98 98T 94T 編数 QTY: 1 1 1 1 名義 NAME: WIRING DIAGRAM (ECO 1/2) YANMAR CO., LTD. ENGINE PRODUCT OPERATIONS DIV.	小形 SCALE 材質 MATERIAL 7 Sec A1 (D)
--	--	---

# Appendix Standard harness (2)

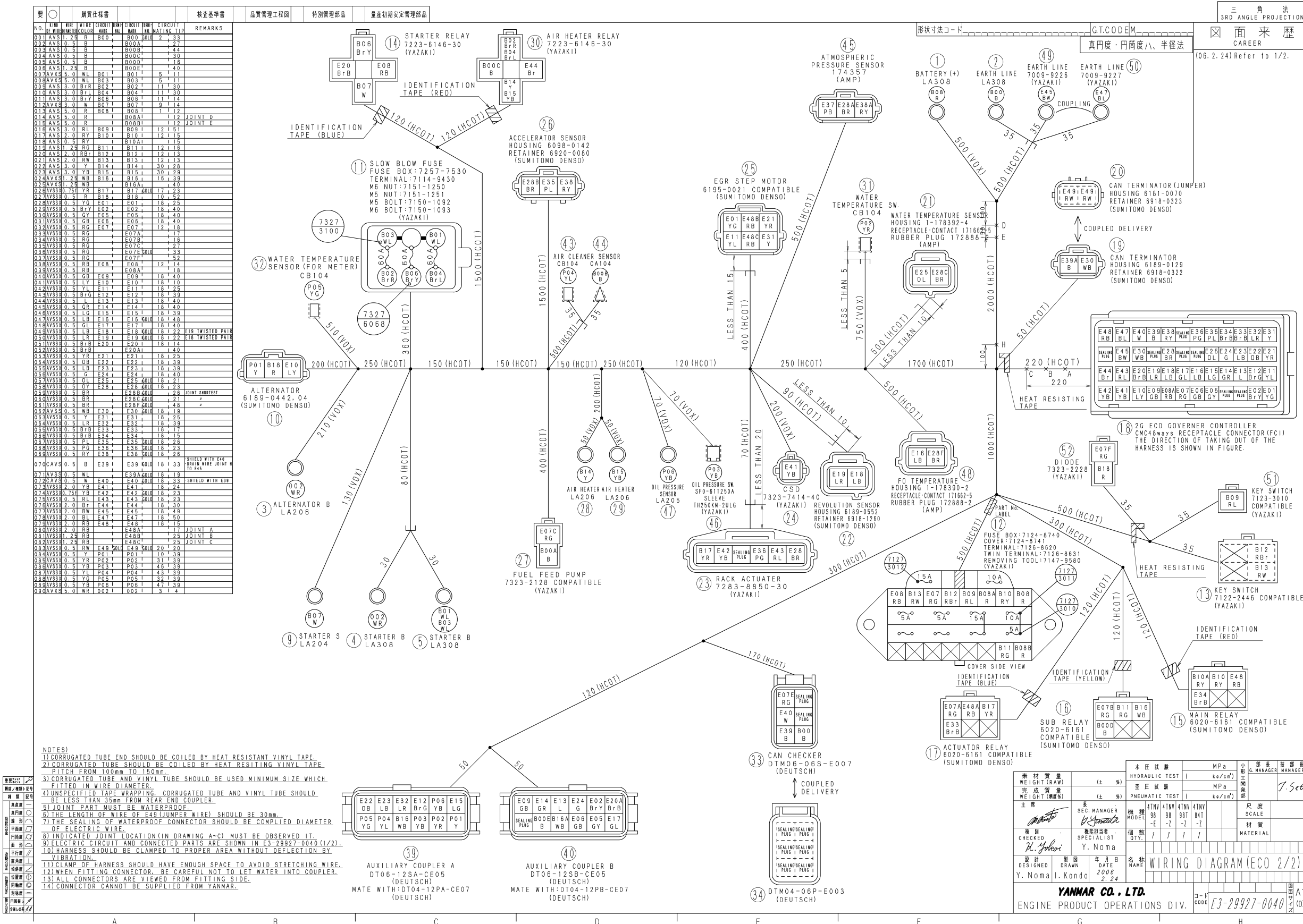

**TNV – Series service tool**  
**Operation Manual**

---

<b>1. Overview</b>	<b>1</b>
<b>2. System Requirements</b>	<b>1</b>
<b>3. Installing the Software</b>	<b>2</b>
<b>4. Description of the System</b>	<b>4</b>
4.1 Description of the Program	4
4.2 Authority and Password Management	4
<b>5. Starting/Quitting the Software</b>	<b>5</b>
5.1 Starting the Software	5
5.1.1 Connecting the System Components	5
5.1.2 Turning on the Devices	5
5.1.3 Installing the USB Driver	5
5.1.4 Startup Screen	7
5.2 Quitting the Software	10
5.3 Troubleshooting	10
<b>6. Screen Components</b>	<b>11</b>
6.1 Basic screen	11
6.1.1 Standard Tool Bar	12
6.1.2 Operation Tool Bar	13
6.1.3 Function Select Tool Bar	15
<b>7. Main Menu</b>	<b>16</b>
7.1 System Information <b>【Universal Function】</b>	16
7.1.1 System Information	16
7.2 Fault Code	17
7.2.1 Active Diagnostic Trouble Code <b>【Universal Function】</b>	17
7.2.2 Logged Diagnostic Trouble Code <b>【Mechanic Function】</b>	18
7.3 Freeze Frame Data <b>【Mechanic Function】</b>	19
7.3.1 Stored Data	19
7.3.2 Trend Graph	21
7.4 Diagnostic Test	22
7.4.1 Analog/Pulse Input/Output Test <b>【Universal Function】</b>	22
7.4.2 Digital Input Test <b>【Universal Function】</b>	23
7.4.3 Digital Output Test <b>【Mechanic Function】</b>	24
7.4.4 Active Control <b>【Mechanic Function】</b>	26
7.4.5 Active Control Graph	28
7.4.6 Hysteresis Measure (Graph Display)	29

7.5 Data Logging 【Mechanic Function】 .....	31
7.5.1 Data Monitor .....	31
7.5.2 Stored Data .....	37
7.5.3 Trend Graph 【Mechanic Function】 .....	38
7.6 Historical Data .....	39
7.6.1 Lifetime Data 【Universal Function】 .....	39
7.6.2 RPM-Load Profile 【Mechanic Function】 .....	40
7.7 ECU Identification 【Mechanic Function】 .....	41
7.7.1 Analog Channels .....	41
7.7.2 Digital Channels 【Mechanic Function】 .....	42
7.7.3 ECU ID Information .....	43
7.8 System Installation .....	44
7.8.1 Configuration 【Mechanic Function】 .....	44
7.8.2 Calibration 【Mechanic Function】 .....	51
7.8.3 Tuning 【Mechanic Function】 .....	52
<b>8. Graph Function .....</b>	<b>53</b>
8.1 Setting the Graphs .....	53
8.1.1 Basic Operations in Analog Mode .....	53
8.1.2 Saving and Loading Setting Values .....	54
8.1.3 Digital Mode .....	55
8.2 Graph Operations .....	56
<b>9. Print Function .....</b>	<b>57</b>
<b>10. Saving and Loading Data .....</b>	<b>57</b>
<b>11. Tool Functions .....</b>	<b>58</b>
11.1 System Setting .....	58
11.2 User Management .....	59
11.3 Changing a Password .....	60
<b>12. Glossary .....</b>	<b>61</b>
<b>13. Appendix .....</b>	<b>61</b>
<b>14. References .....</b>	<b>62</b>

# 1. Overview

---

The YANMAR Engine Diagnostic Service Tool (YEDST) for the TNV series is software to support troubleshooting and installation/maintenance services for electronic control engines. It runs on personal computers (PC/AT) running Windows operating system.

## 2. System Requirements

---

The following are required to operate the YANMAR Engine Diagnostic Service Tool (YEDST).

### PC·····PC/AT compatible

- Communication port : USB
- Display resolution : 1024 × 768
- OS : Windows 2000 Professional SP1, Windows XP Professional, Windows XP Home, Windows XP Tablet PC Edition

### Communication IF box

- Firmware version : 02.15
- DLL version : 02.00
- API version : 02.02

### Cables

- USB cable
- Diagnostic cable

## 3. Installing the Software

---

- 1) Log in as an administrator.
- 2) Run the Setup.exe file on the CD-ROM.

The screen as shown below appears.

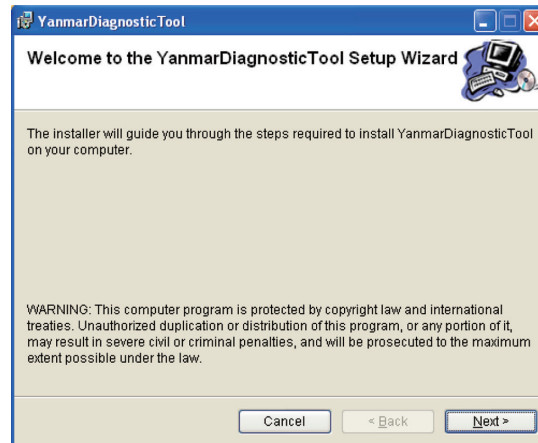

Press the **Next>** button.

The screen as shown below appears.

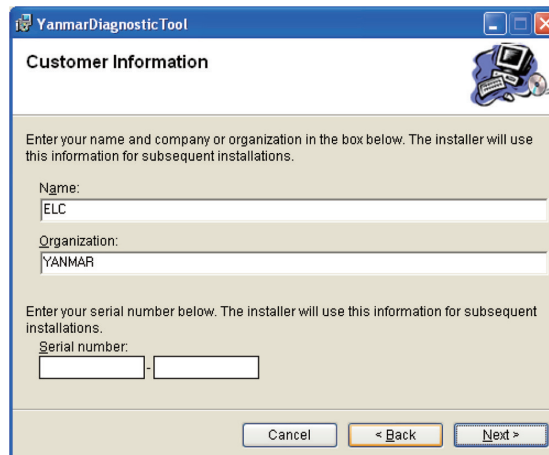

Enter your name and organization. Enter the serial number of your product, and press the **Next>** button. If this number is not correct, the program does not operate normally.

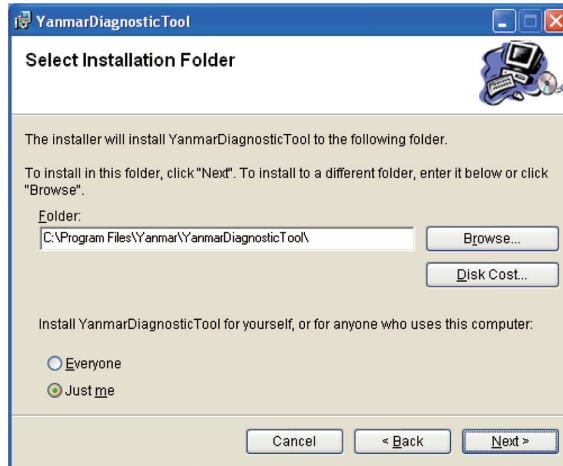

Choose a folder to install the program, and press the **Next>** button. The confirmation screen appears.

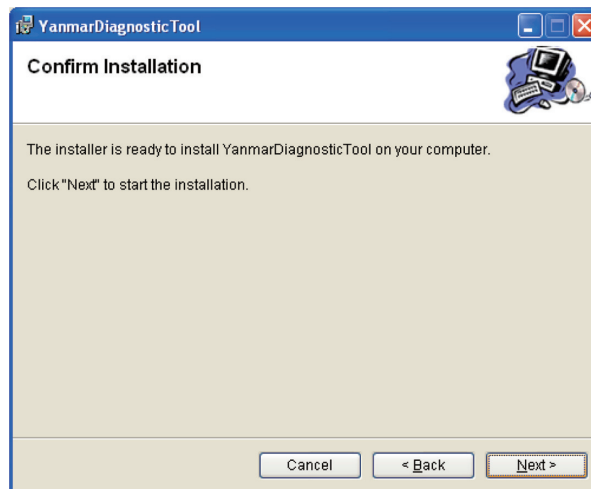

Press the **Next>** button. Installation starts.

When the installation is completed, the screen as shown below appears. Click the **Close** button.

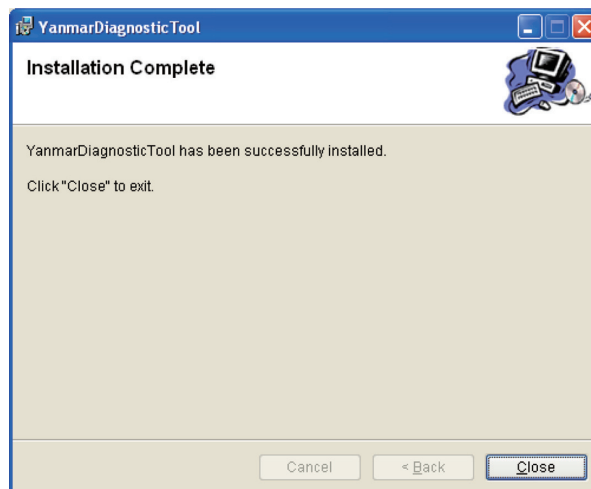

## 4. Description of the System

---

### 4.1 Description of the Program

---

1) Diagnostic software

This is the main software to support troubleshooting and installation/maintenance services by connecting the ECU and your PC (Figure 4-1). At startup, you can change ECU's ID number and communication speed settings.

2) Training mode

This mode lets you learn how to use the diagnostic software using your PC only without connecting to the ECU. You can operate the tool and simulate the operation of the ECU using data stored on your PC.

3) System setting program

This is software to set the communication conditions for the ECU. If you need to change conditions other than ECU's hardware address number and communication speed, you need to run this program in advance. This function is included in the tool function of the diagnostic software.

### 4.2 Authority and Password Management

---

Functions are divided into 2 groups depending on their service function level. Different passwords can be set for each function level.

1) Standard mode (universal functions)

Functions that are equivalent to those of the display panel and open to general users. Only these functions are available when you log in with a user-level password.

2) Mechanic mode (mechanic functions)

Functions that are used by maintenance staff and not open to general users. These functions are available only when you log in with an administrator-level password. For clearing data or changing setting values, a password is prompted again when data is written, even if you logged in with an administrator-level password. Once you enter your password, you can continue operation for 10 minutes without reentering the password.

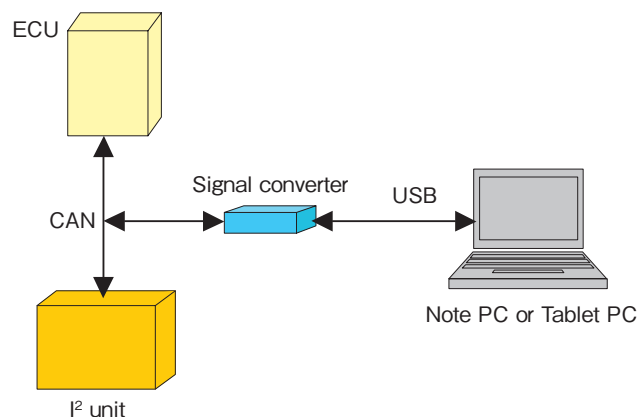

Figure 4-1 System Connection

# 5. Starting/Quitting the Software

---

## 5.1 Starting the Software

---

### 5.1.1 Connecting the System Components

- ① Connect the USB cable between the USB port of the PC and the USB port of the interface box.
- ② Connect the diagnostic cable to CN1 (D-SUB 9P male connector) of the interface box.
- ③ Connect the diagnostic cable to the service connector of the engine.

Handle the cable carefully. The power to the interface box is supplied from the engine system. So, using a damaged cable or shorting the terminals of the cable connector is highly dangerous.

### 5.1.2 Turning on the Devices

There is no specific order to turn on the devices. However, the engine system must be on (the ignition key is on) before you start the application software except when you use it in training mode.

### 5.1.3 Installing the USB Driver

When you connect to the system for the first time after installing the application, you need to install the USB driver.

When you connect to the system, the screen as shown below appears. Select "Install from a list of specific location (advanced) " and click **Next>** .

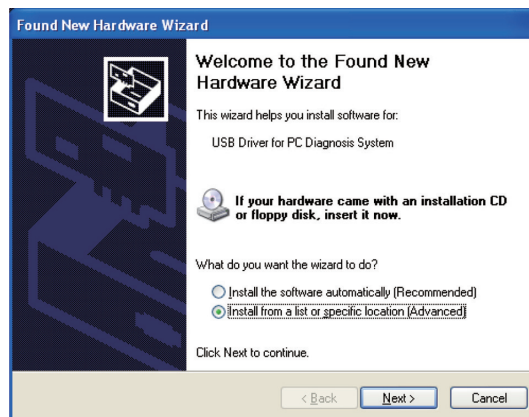

## 6 — 5. Starting/Quitting the Software

Choose the ¥Setup¥Driver folder under the folder where you installed the application in Chapter 3, and click **Next>**.

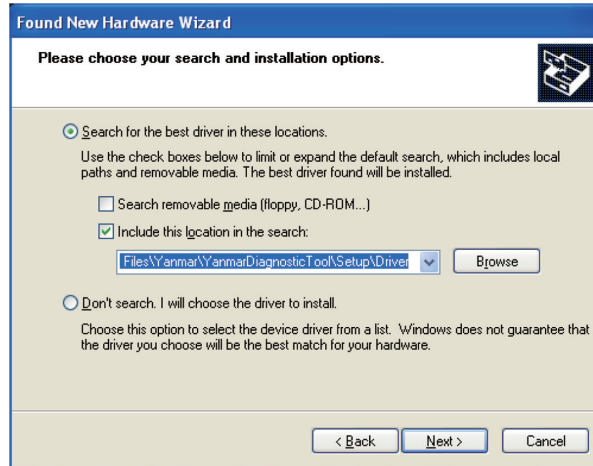

For Windows XP, the screen as shown below appears. Click **Continue Anyway** to continue the installation.



The location where the driver file exists is asked. Choose ¥Setup¥Driver under the folder where you installed the application, and click **OK**.

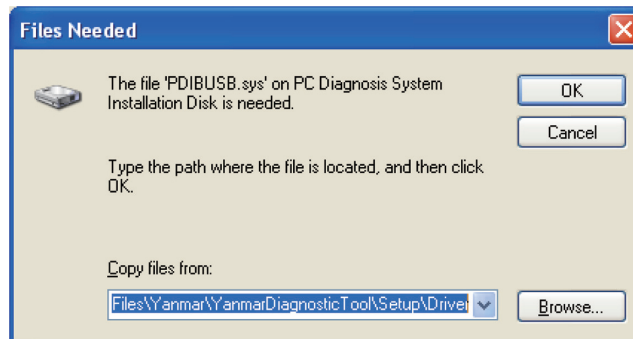

Now, the driver has been installed.

## 5.1.4 Startup Screen

### 1) Registering a user ID and password (first session)

Double click the icon created during the installation (Engine Diagnostic Tool). Only in your first session, the screen as shown in Figure 5-1 appears. Enter the following items. Be sure to memorize the administrator-level password. If you forget it, you cannot log in.

- ① **User ID** : Enter a name to identify the user.
- ② **Password** : Enter a password.
- ③ **[Reinput]** : Enter the password you entered in ② again for confirmation.
- ④ **Authority** : Select an authority level. Select  **Mechanic** in your first session.
- ⑤ **Explanation** : Enter a comment as necessary. You can omit it.
- ⑥ Click the **OK** button to set the entries. The screen to enter a password as shown in Figure 5-2 appears.

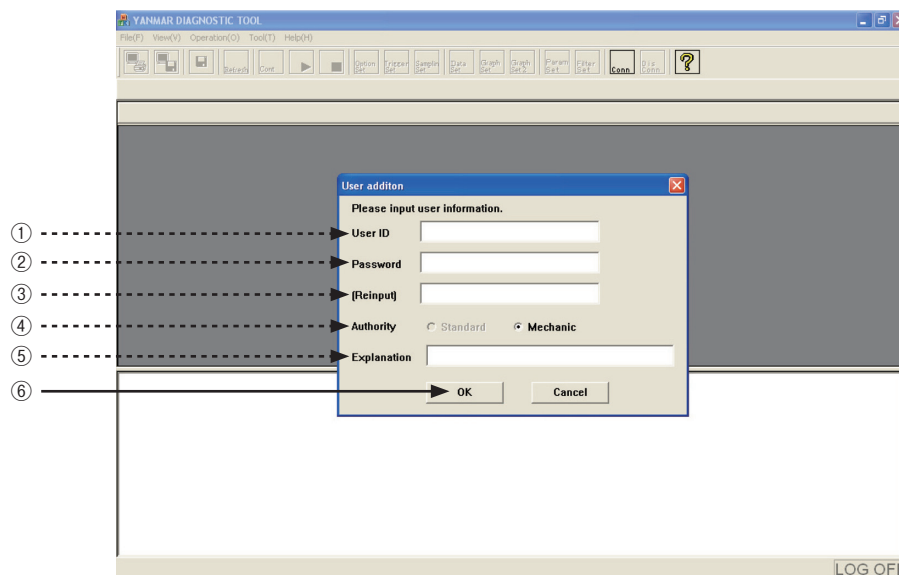

Figure 5-1 Screen to Register a User ID and Password (First Session)

## 8 — 5. Starting/Quitting the Software

### 2) Entering the user ID and password

The entry screen as shown in Figure 5-2 appears after the registration in the first session and in second and later sessions.

- ① **User ID** : Enter a registered ID.
- ② **Password** : Enter the password for the user ID.
- ③ Check the entries, and click the **Login** button.

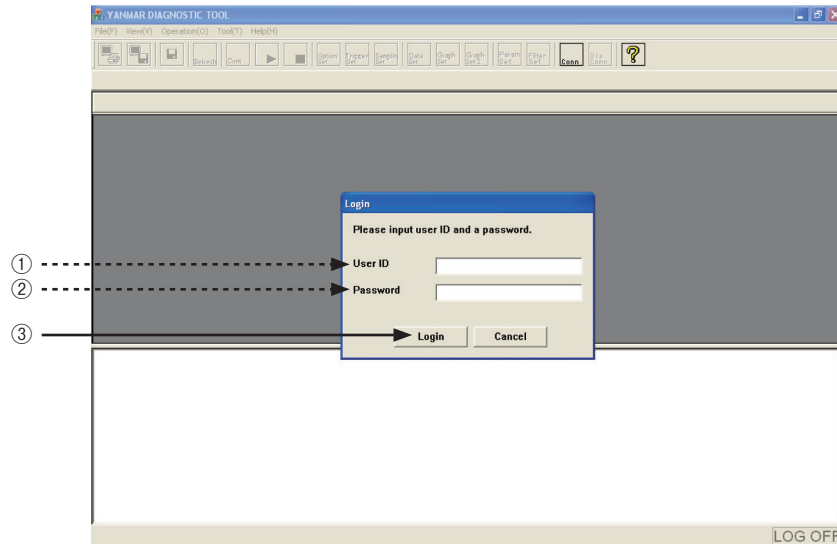

Figure 5-2 Screen to Enter a User ID and Password

## 3) System settings

The following screen lets you set the conditions of communication with the ECU, including ECU's hardware address number, communication speed, and other conditions. Note that this function is included also in the tool function of the diagnostic software.

- ① **Data Rate** : Set the CAN communication speed (baud rate). The standard setting for marine applications is 250k, and that for land applications is 500k. For some models, the baud rates are changed. Refer to the specification document.
- ② **Address** : Set ECU's physical address. Usually, it is 0. When multiple ECU's are connected to one CAN line, you need to change the address.
- ③ **Training Mode** : When you want to use training mode, click this button.
- ④ **System Setting** : This button provides the same function as the one called by choosing [Tool] - [System Setting] on the main screen. (Refer to Section 11.1)
- ⑤ **Version** : Displays the hardware and software versions of the tool software, interface box, etc.
- ⑥ **Exit** : Clicking this button closes the setting screen.

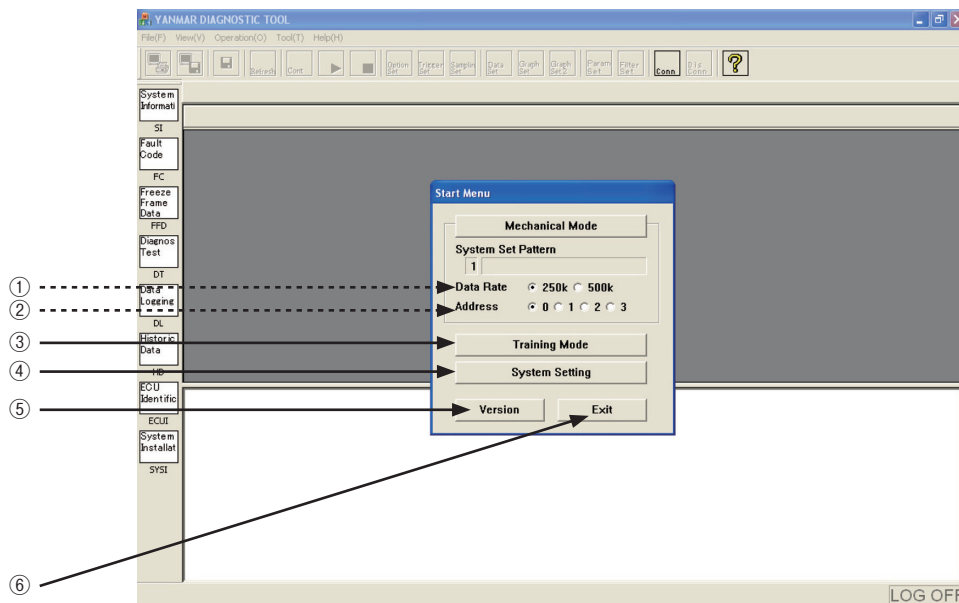

Figure 5-3 System Setting Screen



## 5.2 Quitting the Software

You can quit the program in the same way as other Windows applications.

Before you turn off the system, you need to quit the PC program.

①  or [File (F)] - [Exit] : The confirmation menu to quit the program appears.

②  : Click this button to quit the program.

Clicking the  icon ③ stops communication temporarily without quitting the program. After adjusting the system, click the  icon again to continue monitoring.

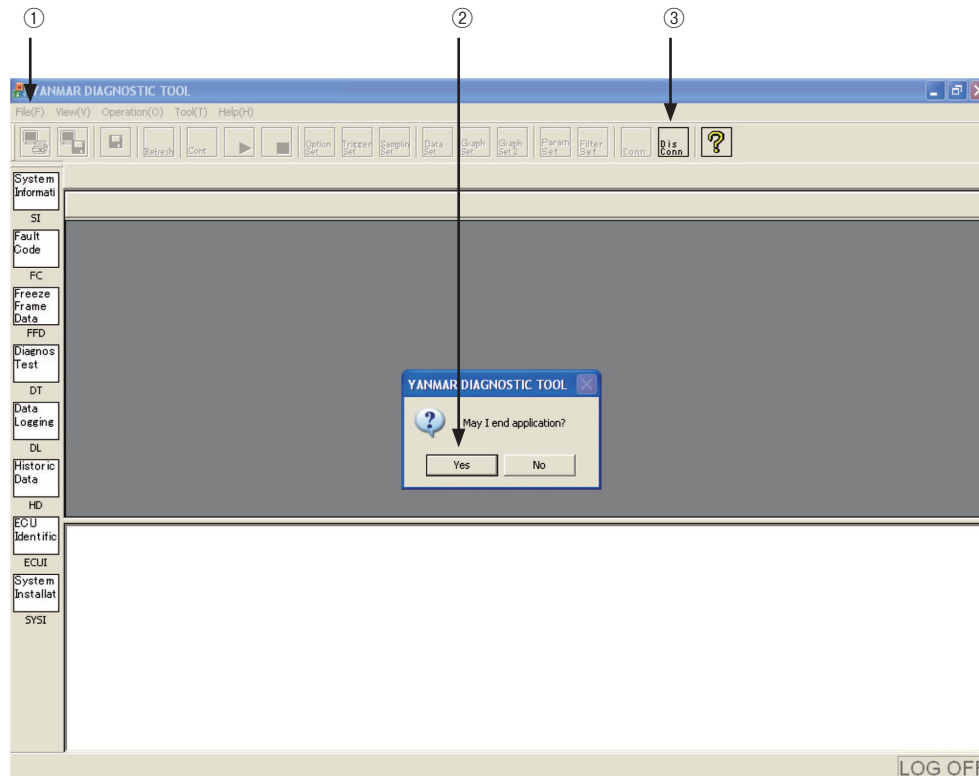

Figure 5.4 Confirmation Screen for Quitting the Program

## 5.3 Troubleshooting

If a communication error occurs and you cannot perform monitoring normally, check the following points, and restart the program. Note that, if a connector is disconnected or the system power is turned off, the system may not recover normally even if you restart the program. In this case, turn off the system once. If you cannot do so, disconnect the diagnostic connector from the service connector, and then connect them again. This operation initializes the CPU inside the interface box, and restores the system operation.

- ① Isn't the cable disconnected? Isn't the cable broken?
- ② Is the system turned on?
- ③ Isn't the system in training mode?
- ④ Isn't the system in disconnect status?
- ⑤ Is the baud rate correct?

# 6. Screen Components

## 6.1 Basic screen

### 1) Tool bar

- ① Standard tool bar : The standard tool bar provides basic operations of ② to ④ . Shortcut keys, [Alt] key + [Parenthesized character], are available.
- ② Operation tool bar : This tool bar provides operations available on each screen. Unavailable operations are displayed dim.
- ③ Function select tool bar : This tool bar lets you select a basic function. It corresponds to View on the standard tool bar.
- ④ View select tool bar : This tool bar lets you select a screen in each function. It corresponds to the submenu of View on the standard tool bar.

### 2) View

- ⑤ Main view : Displays the details of the selected function.
- ⑥ Additional Information view : Display area specific to screens that show graphs and chronological data.
- ⑦ Comment view : This view usually displays the current trouble status. On the screen to display trouble codes, it displays trouble criteria and troubleshooting results.
- ⑧ Status view : Displays the current communication status.

### 3) Function buttons

Functions not supported by the standard tool bar (Clear button, etc) are displayed as buttons in the Main view and Additional Information view.

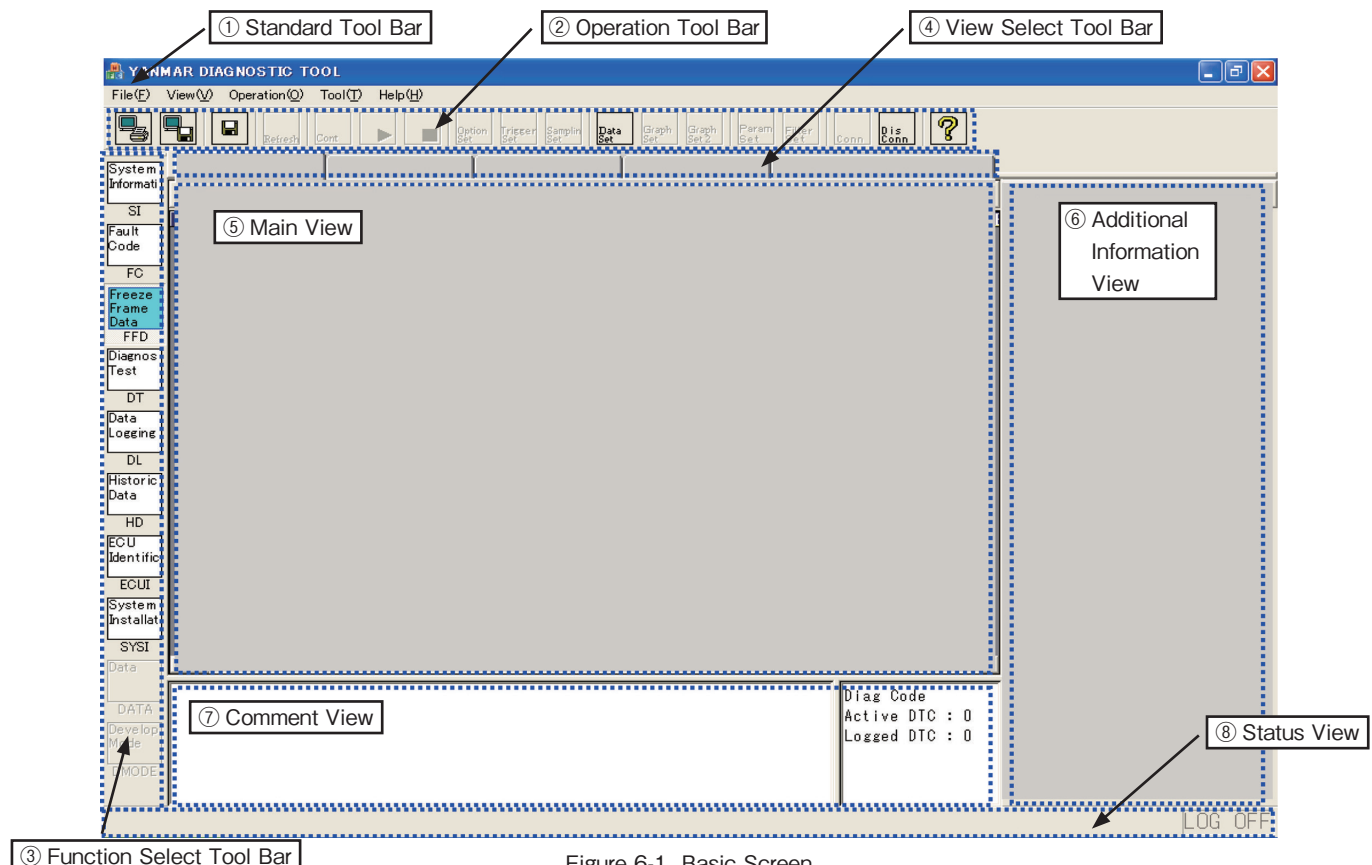

Figure 6-1 Basic Screen

### 6.1.1 Standard Tool Bar

This tool bar lets you select a function, screen, operation, and tool by clicking the corresponding button. Alternatively, you can select an item by pressing the parenthesized character after the item and the [Alt] key at the same time (shortcut key) with the menu displayed.

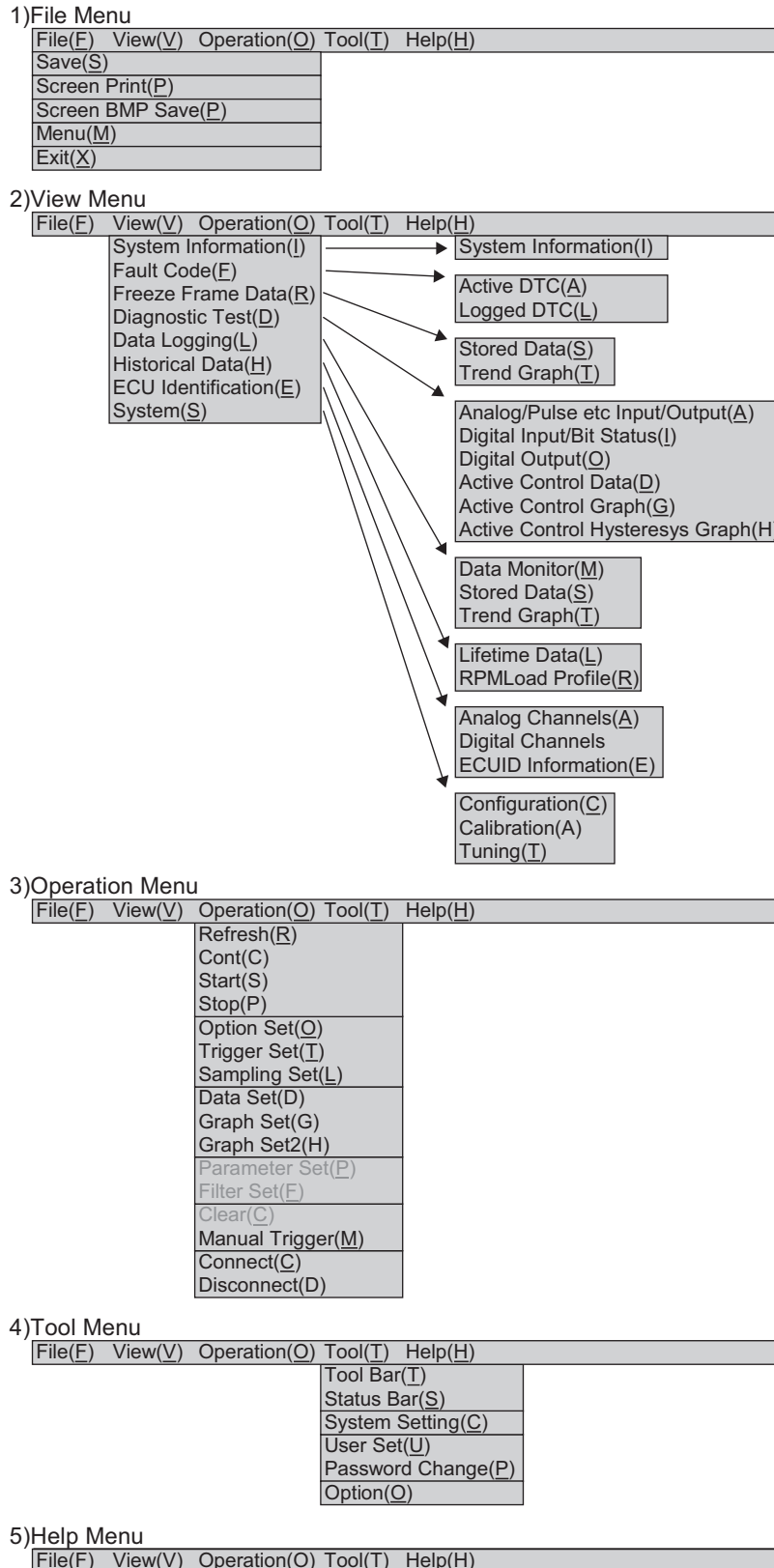

Figure 6-2 Menu Tree of the Standard Tool Bar

## 6.1.2 Operation Tool Bar

This tool bar lets you select an operation available on each screen by clicking the corresponding button. Unavailable operations are displayed dim.

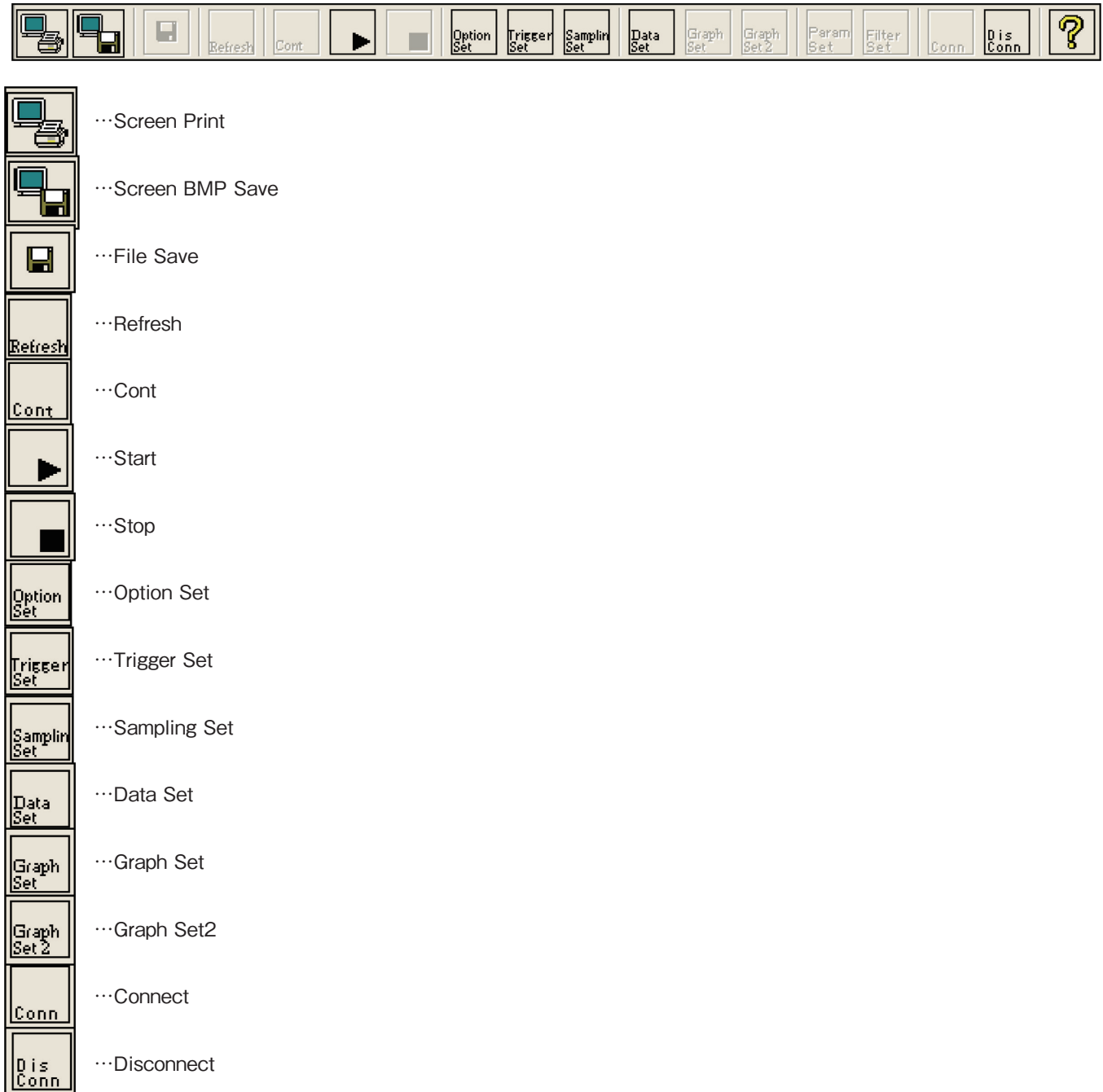

Figure 6-3 Operation Tool Bar

Table 6-1 Operation Tools Available on Each Menu

Menu		Submenu	Control (Toll Bar Button)													
			Print	Screen BMP Sav	File Save	Refresh	Cont	Start	Stop	Option Set	Trigger Set	Sampling Set	Data Set	Graph Set	Graph Set2	Connect
System Information	SI	-	<input type="radio"/>	<input type="radio"/>	<input type="radio"/>	<input type="radio"/>									<input type="radio"/>	<input type="radio"/>
Fault Code	FC	Active DTC	<input type="radio"/>	<input type="radio"/>	<input type="radio"/>	<input type="radio"/>									<input type="radio"/>	<input type="radio"/>
		Logged DTC	<input type="radio"/>	<input type="radio"/>	<input type="radio"/>	<input type="radio"/>									<input type="radio"/>	<input type="radio"/>
Freeze Frame Data	FFD	Stored Data	<input type="radio"/>	<input type="radio"/>	<input type="radio"/>							<input type="radio"/>			<input type="radio"/>	<input type="radio"/>
		Trend Graph	<input type="radio"/>	<input type="radio"/>									<input type="radio"/>	<input type="radio"/>	<input type="radio"/>	<input type="radio"/>
Diagnostic Test	TC	Analog/Pulse etc Input/Output	<input type="radio"/>	<input type="radio"/>	<input type="radio"/>	<input type="radio"/>	<input type="radio"/>		<input type="radio"/>			<input type="radio"/>			<input type="radio"/>	<input type="radio"/>
		Digital Input/Bit Status	<input type="radio"/>	<input type="radio"/>	<input type="radio"/>	<input type="radio"/>	<input type="radio"/>		<input type="radio"/>						<input type="radio"/>	<input type="radio"/>
		Digital Output	<input type="radio"/>	<input type="radio"/>	<input type="radio"/>	<input type="radio"/>	<input type="radio"/>		<input type="radio"/>						<input type="radio"/>	<input type="radio"/>
		Active Control Data	<input type="radio"/>	<input type="radio"/>	<input type="radio"/>										<input type="radio"/>	*
		Active Control Graph	<input type="radio"/>	<input type="radio"/>	<input type="radio"/>									<input type="radio"/>		<input type="radio"/>
Data Logging	DL	Data Monitor	<input type="radio"/>	<input type="radio"/>				<input type="radio"/>	<input type="radio"/>	<input type="radio"/>	<input type="radio"/>	<input type="radio"/>			<input type="radio"/>	<input type="radio"/>
		Stored Data	<input type="radio"/>	<input type="radio"/>	<input type="radio"/>							<input type="radio"/>			<input type="radio"/>	<input type="radio"/>
		Trend Graph	<input type="radio"/>	<input type="radio"/>				<input type="radio"/>	<input type="radio"/>				<input type="radio"/>	<input type="radio"/>	<input type="radio"/>	*
Historical Data	HD	Lifetime Data	<input type="radio"/>	<input type="radio"/>	<input type="radio"/>	<input type="radio"/>								<input type="radio"/>	<input type="radio"/>	
		RPM-Load Profile	<input type="radio"/>	<input type="radio"/>	<input type="radio"/>								<input type="radio"/>		<input type="radio"/>	<input type="radio"/>
ECU Identification	ECU_I	Analog Channels	<input type="radio"/>	<input type="radio"/>	<input type="radio"/>										<input type="radio"/>	<input type="radio"/>
		Digital Channels	<input type="radio"/>	<input type="radio"/>	<input type="radio"/>										<input type="radio"/>	<input type="radio"/>
		ECUID Information	<input type="radio"/>	<input type="radio"/>	<input type="radio"/>	<input type="radio"/>									<input type="radio"/>	<input type="radio"/>
System	SYS_I	Configuration	<input type="radio"/>	<input type="radio"/>	<input type="radio"/>										<input type="radio"/>	<input type="radio"/>
		Calibration	<input type="radio"/>	<input type="radio"/>	<input type="radio"/>										<input type="radio"/>	<input type="radio"/>
		Tuning	<input type="radio"/>	<input type="radio"/>	<input type="radio"/>										<input type="radio"/>	<input type="radio"/>

\* : Disconnect is not available during active control operation and during data reception for data logging.

### 6.1.3 Function Select Tool Bar

This tool bar lets you select a service tool function by clicking the corresponding button. It corresponds to View on the standard tool bar.

Image	Name	Abbreviation	Description
System Information SI	System Information	SI	Trouble data
Fault Code FC	Fault Code	FC	Trouble data
Freeze Frame Data FFD	Freeze Frame Data	FFD	Data before & after failure
Diagnostic Test DT	Diagnostic Test	DT	System check
Data Logging DL	Data Logging	DL	Analysis of engine trouble on operation
Historic Data HD	Historical Data	HD	Information of engine operation and maintenance
ECU Identification ECUI	ECU Identification	ECU_I	Data of engine, System or ECU
System Installation SYSI	System Installation	SYS_I	Engine setting and repair after installation





# 7. Main Menu

## 7.1 System Information [Universal Function]

### 7.1.1 System Information

The key system information stored in the ECU is displayed.

#### 1) Operation tool bar

- ①  : Prints a hardcopy of the screen.
- ②  : Saves the screen in BMP format.
- ③  : Saves data on the screen in CSV format.
- ④  : Refreshes the system information.

#### 2) Main view

- ⑤ **Classification** : Classification of a displayed item.
- ⑥ **Description** : Name of an item.
- ⑦ **Value** : Displays the system information.
- ⑧ **Unit** : Unit.

#### 3) Comment view

- ⑨ "Notes" field : Displays notes.

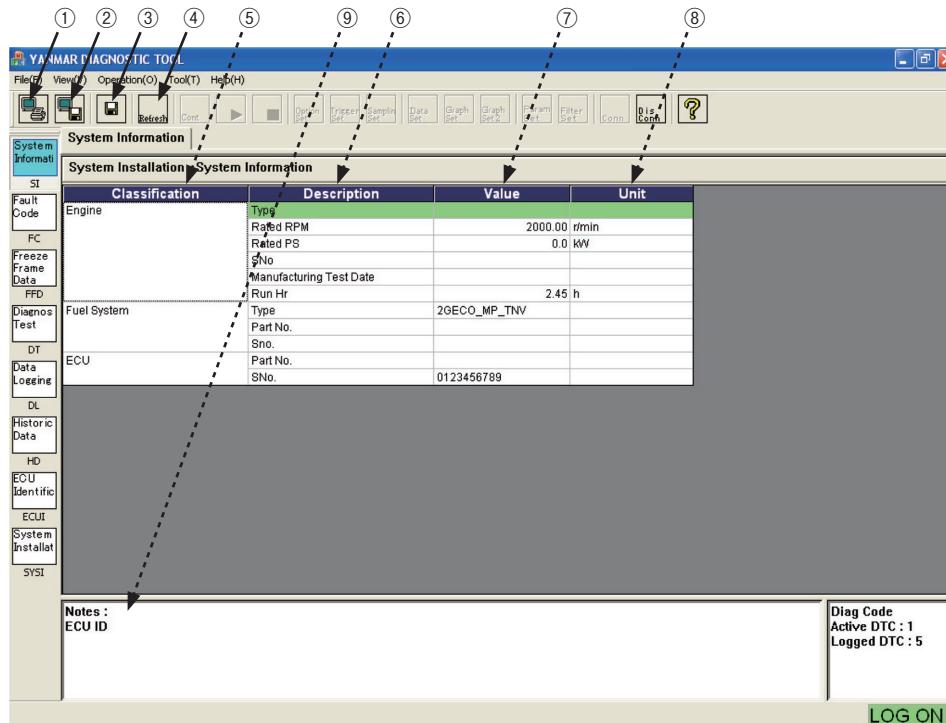

Figure 7-1 System Information Screen



## 7.2 Fault Code

This function is used to display current and past faults detected by the ECU. By clicking on the Screen Select tool bar, you can select Active Diagnostic Trouble Code or Logged Diagnostic Trouble Code.

### 7.2.1 Active Diagnostic Trouble Code [Universal Function]

This function is used to list current troubles detected by the ECU in real time (automatically updated at intervals of 2 seconds). Trouble codes and their description are displayed. In the Notes field in the lower part of the screen, brief explanation and remedy for the trouble for the cursor line are displayed. When the cause of the trouble is removed and normal operation is restored, the trouble display on the screen disappears.

#### 1) Operation tool bar

- ①  : Prints a hardcopy of the screen.
- ②  : Saves the screen in BMP format.
- ③  : Saves data on the screen in CSV format.

#### 2) Main view

- ④ **Code** : Displays a trouble code (DTC) complying with SAE J2012.
- ⑤ **Description** : Displays the description of the trouble code.
- ⑥ **Probable cause** : Shows a probable cause of the trouble.

#### 3) Comment view

- ⑦ "Probable cause", "Action" field : Shows the troubleshooting result for the trouble for the clicked cursor line (painted in light blue) as a guidance for required action.

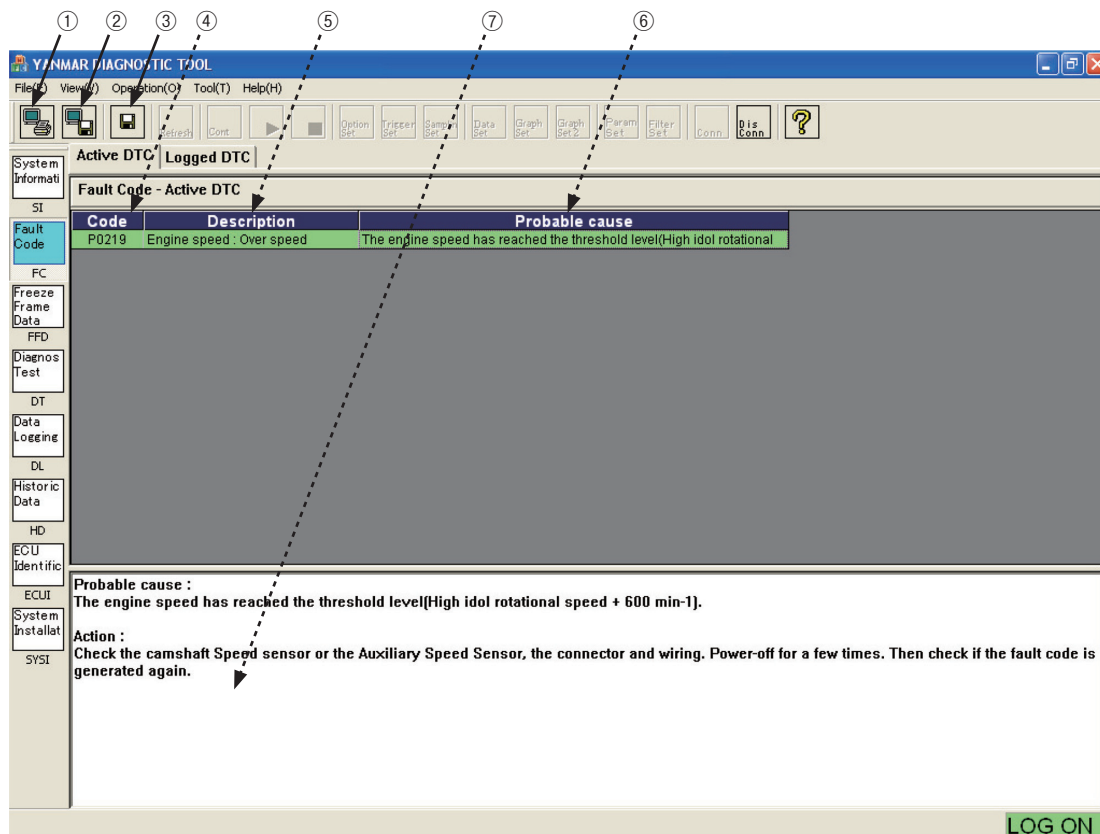

Figure 7-2 [Fault Code] - [Active Diagnostic Trouble Code] Screen

## 7.2.2 Logged Diagnostic Trouble Code [Mechanic Function]

This screen lists logged troubles stored in the nonvolatile memory of the ECU. For each trouble code, its description, the number of occurrences, and the first and last occurrence clock times are displayed. You can delete logged troubles item by item or all at once.

### 1) Operation tool bar

- ① : Prints a hardcopy of the screen.
- ② : Saves the screen in BMP format.
- ③ : Saves all log data in a CSV file.
- ④ : Refreshes all log data.

### 2) Function buttons

- ⑤ **CLEAR Logged DTC** : Deletes data items for which the "Clear" field is checked.

### 3) Main view

- ⑥ **Clear** : Shows whether it will be deleted. (Click a checkbox to checkmark it.)
- ⑦ **Active** : A lit lamp mark is displayed for current troubles.
- ⑧ **Code** : Displays a trouble code (DTC) complying with SAE J2012.
- ⑨ **FMI** : Shows a failure mode. (See 13.2.)
- ⑩ **Description** : Displays the description of a trouble code.
- ⑪ **OC** : Occurrence counter : Shows the total number of occurrences of the same trouble.
- ⑫ **First** : Shows the time of the first occurrence of the trouble (cumulative time of engine operation).
- ⑬ **Latest** : Shows the time of the latest occurrence of the trouble (cumulative time of engine operation).

### 4) Comment view

- ⑭ "Probable cause"" Action" field : Shows a probable cause of the trouble for the clicked cursor line.

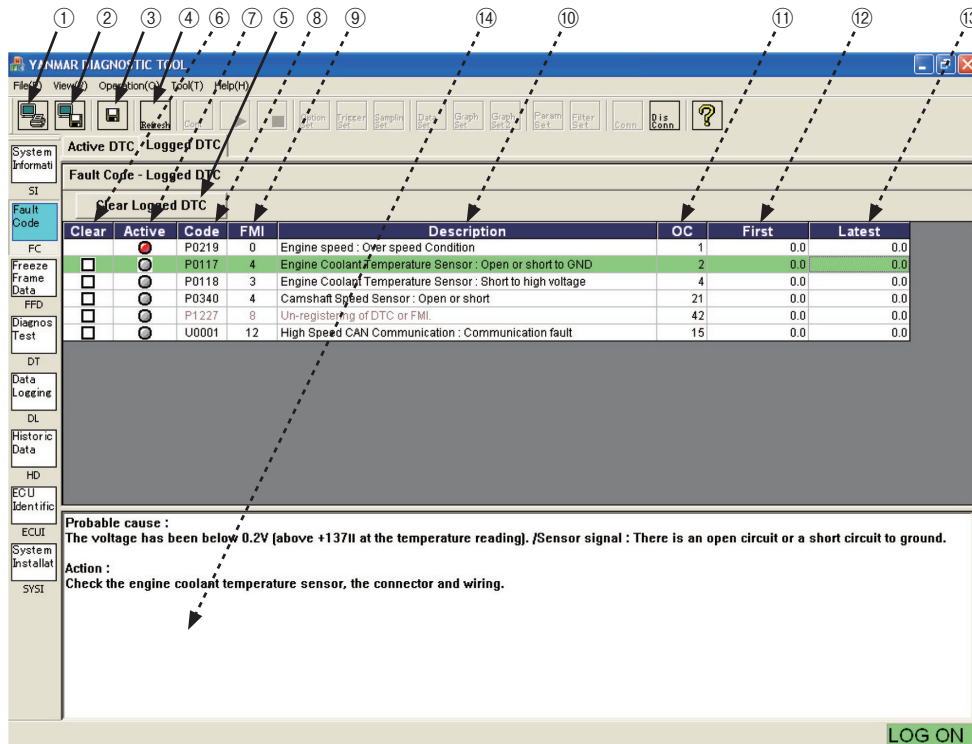

Figure 7-3 [Fault Code] - [Logged Diagnostic Trouble Code] Screen

## 7.3 Freeze Frame Data [Mechanic Function]

This function is used to display related data before and after the detection of recent serious troubles. By clicking the Screen Select tool bar, you can view the data list and trend graph.





### 7.3.1 Stored Data

#### 1) Additional Information view

Stored FFD items are listed. The data for the clicked field is displayed in the Main view.

- ① **No.** : Shows the frame number of the FFD.
- ② **DTC** : Trouble code (you can check the details on the Logged DTC screen.)
- ③ **Time** : Shows the time of the trouble (cumulative engine operation time).

#### 2) Operation tool bar

- ④  : Prints a hardcopy of the screen.
- ⑤  : Saves the screen in BMP format.
- ⑥  : Saves buffered data in a CSV file.
- ⑦  : Refreshes FFD data.
- ⑧  : Displays the Data Select sub-window, which lets you add/delete and sort displayed data.

#### 3) Function buttons

- ⑨ **Clear FFD** : Deletes the selected FFD.

#### 4) Main view

- ⑩ **No.** : Shows the chronological ordinal number of data.
- ⑪ **Item** : Displays the acronym of the specified data names (you can check the details such as name and unit on the ECU Identification screen). You can change the data display format (decimal/hexadecimal) by right-clicking the item field.

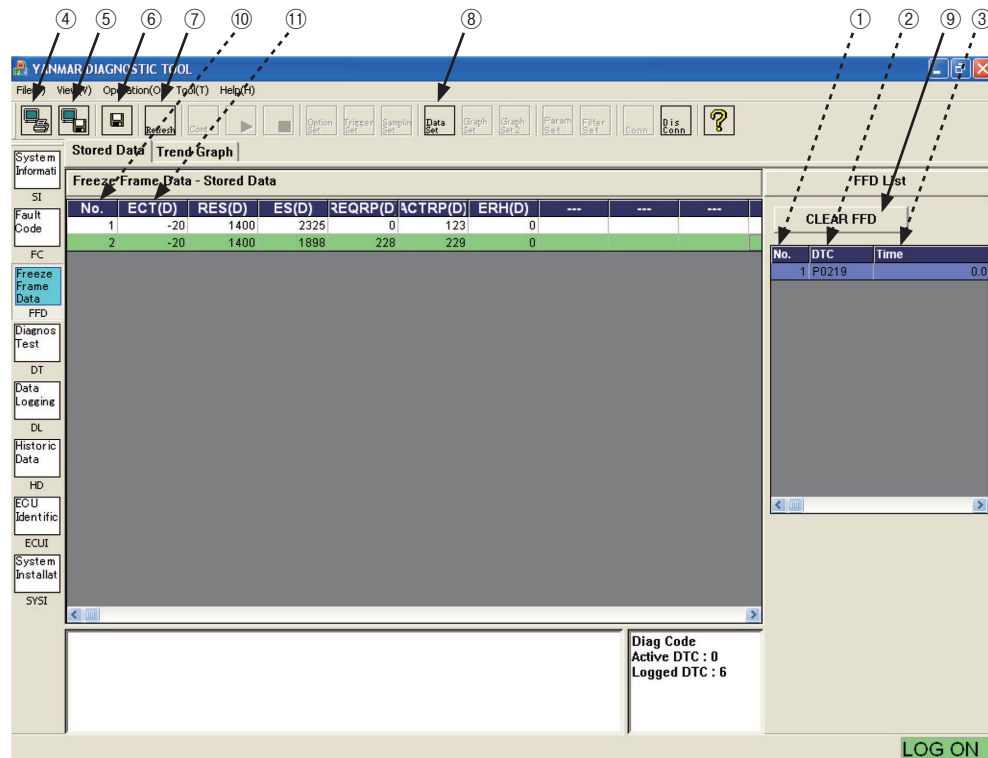

Figure 7-4 [FFD] - [Stored Data] Screen

5) Data Select sub-window

You can select data to be displayed on the Main view.

- ① "DATA" : Displays the list of data items that can be displayed.
- ② ◀ / ▶ : Selects/deselects a data item to be displayed.
- ③ Default : Restores the default settings.
- ④ "Set Data" : Data items displayed in the Main view.
- ⑤ ▲ / ▼ : Changes the display order of the selected data.
- ⑥ Set : Sets the entered information.
- ⑦ Cancel : Cancels the entered information.

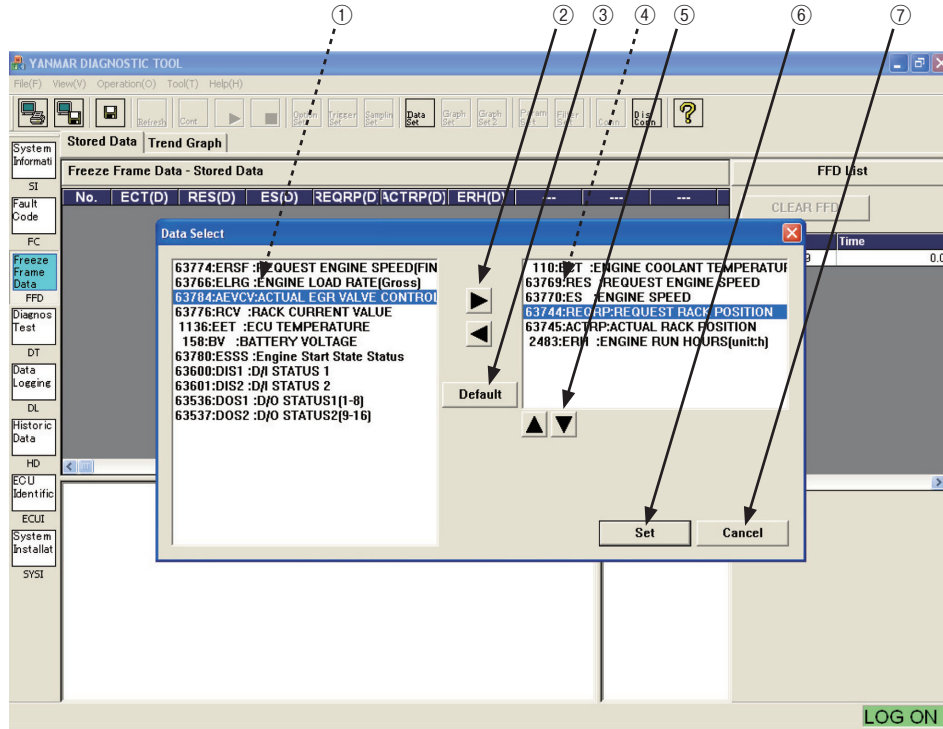

Figure 7-5 [FFD] - [Stored Data] - [Data Select] Sub-Window Screen

## 7.3.2 Trend Graph

### 1) Additional Information view (Cursor Value)

The data item names selected in graph setting operation and the values at the cursor position are displayed.

<Graph 1> : Cursor values of Graph Top. <Graph 2> : Cursor values of Graph Bottom.

① "Position" : Displays the data number at the cursor point.

② "Displayed item and data" : Displays an item name and data. The background color corresponds to the graph line color.

### 2) Operation tool bar

③  : Prints a hardcopy of the screen.

④  : Saves buffered data in a CSV file.

⑤  : Lets you specify displayed items and scaling for the top graph.

⑥  : Lets you specify displayed items and scaling for the bottom graph.

### 3) Main view

Displays graph 1 and graph 2. For information on operations related to graphs, see Chapter 8.

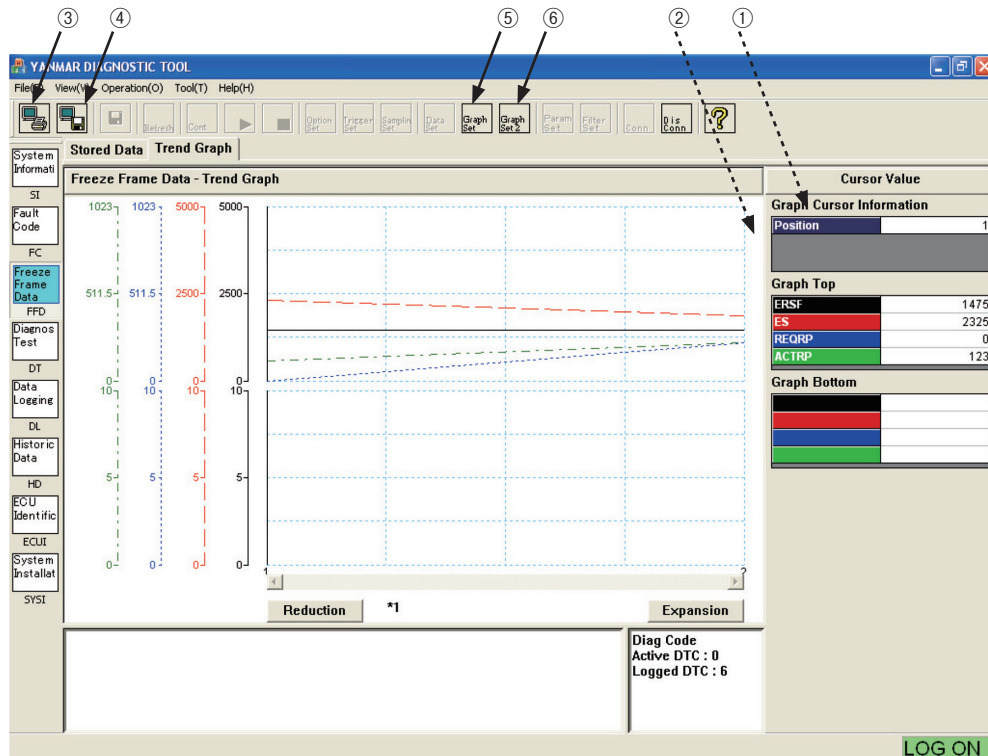

Figure 7-6 [FFD] - [Trend Graph] Screen







## 7.4 Diagnostic Test

This function lets you check input/output devices individually. To select an test item, click one of the tabs for input/output tests and active control on the Screen Select tool bar. Some of the functions requiring output are available only when the clutch is in neutral and the engine is in low idle or stopped.

### 7.4.1 Analog/Pulse Input/Output Test [Universal Function]

This function is used to check the operation of input devices after troubleshooting and repair. You can check analog measured values and pulse input values. When the screen is selected, the screen display is automatically refreshed at intervals of 2 seconds by default.

#### 1) Operation tool bar

- ①  : Prints a hardcopy of the screen.
- ②  : Saves the screen in BMP format.
- ③  : Saves data on the screen in a CSV file.
- ④  : Refreshes the current value data.
- ⑤  : Refreshes the current value data continuously. (At intervals of 2 seconds)
- ⑥  : Stops continuous refreshing.
- ⑦  : After pressing Stop, lets you change the data display order. You can reposition desired items for ease of view. For more information on operations, see 7.3.5) of FFD.

#### 2) Main view

- ⑧ **Description** : Displays input device names.
- ⑨ **Value** : Displays measured values.
- ⑩ **Unit** : Unit.
- ⑪ **Signal Data** : Voltage value of analog input (unit : mV)
- ⑫ **Notes** : Field for notes.

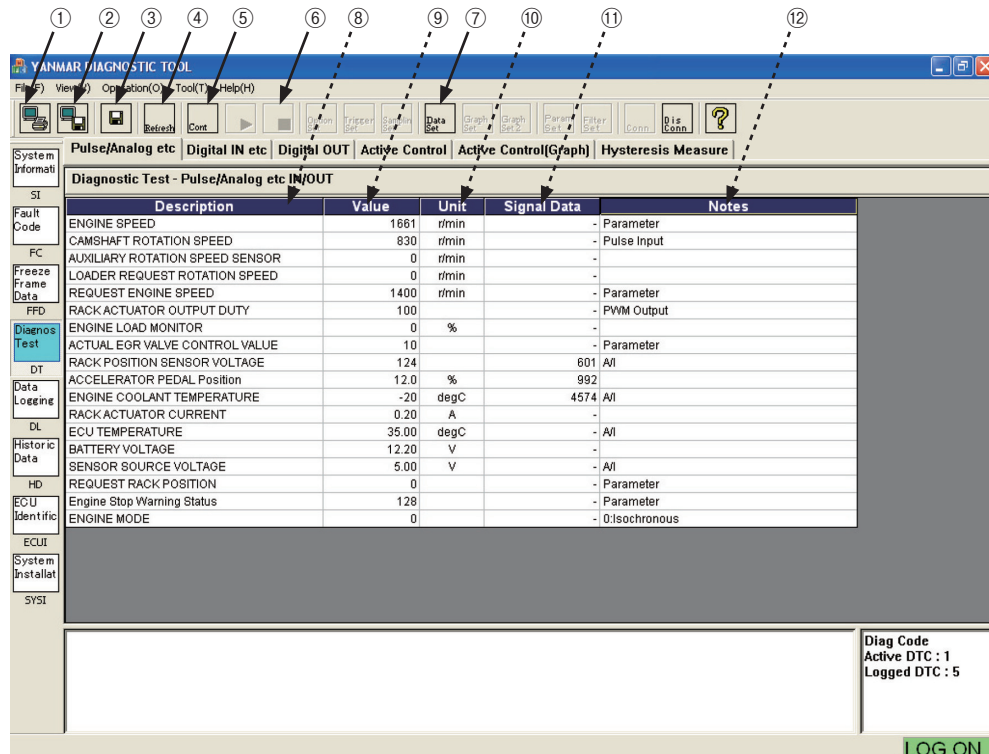

The screenshot shows the YANMAR DIAGNOSTIC TOOL interface. The main window displays a table of diagnostic data for the 'Pulse/Analog etc' test. The table has five columns: Description, Value, Unit, Signal Data, and Notes. The data is as follows:

	Description	Value	Unit	Signal Data	Notes
SI	ENGINE SPEED	1681	r/min	-	Parameter
	CAMSHAFT ROTATION SPEED	830	r/min	-	Pulse Input
FC	AUXILIARY ROTATION SPEED SENSOR	0	r/min	-	-
Freeze Frame Data	LOADER REQUEST ROTATION SPEED	0	r/min	-	-
	REQUEST ENGINE SPEED	1400	r/min	-	Parameter
FFD	RACK ACTUATOR OUTPUT DUTY	100	-	-	PWM Output
	ENGINE LOAD MONITOR	0	%	-	-
Diagnos Test	ACTUAL EGR VALVE CONTROL VALUE	10	-	-	Parameter
DT	RACK POSITION SENSOR VOLTAGE	124	-	601 Af	-
Data Logging	ACCELERATOR PEDAL Position	12.0	%	992	-
	ENGINE COOLANT TEMPERATURE	-20	degC	4574 Af	-
	RACK ACTUATOR CURRENT	0.20	A	-	-
DL	ECU TEMPERATURE	35.00	degC	-	Af
Historic Data	BATTERY VOLTAGE	12.20	V	-	-
	SENSOR SOURCE VOLTAGE	5.00	V	-	Af
HD	REQUEST RACK POSITION	0	-	-	Parameter
ECU Identific	Engine Stop Warning Status	128	-	-	Parameter
	ENGINE MODE	0	-	-	0:isochronous







At the bottom right of the interface, a status box displays: **Diag Code**, **Active DTC : 1**, and **Logged DTC : 5**. A **LOG ON** button is located at the bottom right corner.

Figure 7-7 [Diagnostic Test] - [Analog/Pulse Input/Output Test] Screen

## 7.4.2 Digital Input Test [Universal Function]

This function is used to check the operation of the input devices after troubleshooting and repair. You can check the ON/OFF status of the contact inputs. When the screen is selected, the screen display is automatically refreshed at intervals of 2 seconds by default.

### 1) Operation tool bar

- ①  : Prints a hardcopy of the screen.
- ②  : Saves the screen in BMP format.
- ③  : Saves data on the screen in a CSV file.
- ④  : Refreshes the current value data.
- ⑤  : Refreshes the current value data continuously. (At intervals of 2 seconds)
- ⑥  : Stops continuous refreshing.

### 2) Main view

- ⑦ **Description** : Displays input device names.
- ⑧ **On/Off** : Shows the ON/OFF status.
- ⑨ **Notes** : Field for notes.

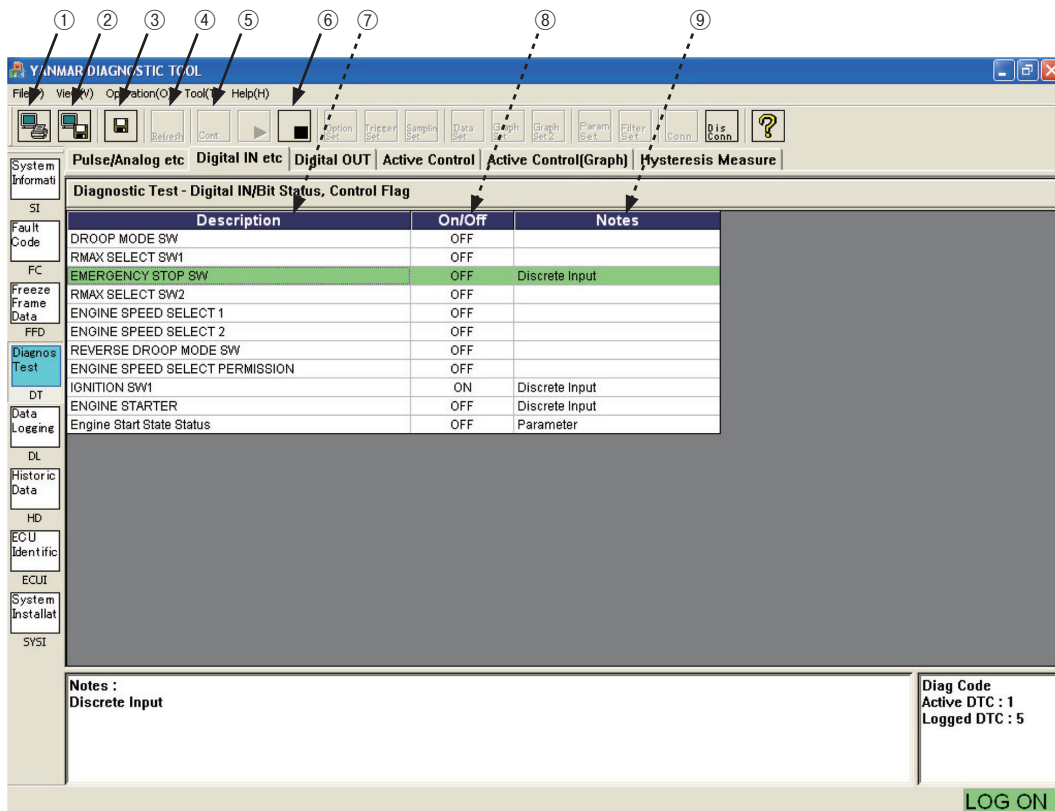

The screenshot shows the 'YANMAR DIAGNOSTIC TOOL' interface. The main display area is titled 'Diagnostic Test - Digital IN/Bit Status, Control Flag'. It contains a table with the following data:

	Description	On/Off	Notes
SI			
Fault Code	DROOP MODE SW	OFF	
	RMAX SELECT SW1	OFF	
FC	EMERGENCY STOP SW	OFF	Discrete Input
	RMAX SELECT SW2	OFF	
Freeze Frame Data	ENGINE SPEED SELECT 1	OFF	
	ENGINE SPEED SELECT 2	OFF	
FFD	REVERSE DROOP MODE SW	OFF	
	ENGINE SPEED SELECT PERMISSION	OFF	
Diagnos Test	IGNITION SW1	ON	Discrete Input
	ENGINE STARTER	OFF	Discrete Input
Data Logging	Engine Start State Status	OFF	Parameter
DL			
Historic Data			
HD			
ECU Identific			
ECUI			
System Installat			
YSI			







At the bottom of the screen, there is a 'Notes' field containing 'Discrete Input' and a 'Diag Code' field showing 'Active DTC : 1' and 'Logged DTC : 5'. A 'LOG ON' button is located at the bottom right corner.

Figure 7-8 [Diagnostic Test] - [Digital Input Test] Screen

### 7.4.3 Digital Output Test 【Mechanic Function】

This function is used to check the operation of output devices after troubleshooting and repair. You can turn ON/OFF contacts forcibly only when the engine is stopped. When the screen is selected, the screen display is automatically refreshed at intervals of 2 seconds by default.

#### 1) Operation tool bar

- ①  : Prints a hardcopy of the screen.
- ②  : Saves the screen in BMP format.
- ③  : Saves data on the screen in a CSV file.
- ④  : Refreshes the current value data.
- ⑤  : Refreshes the current value data continuously. (At intervals of 2 seconds)
- ⑥  : Stops continuous refreshing.

#### 2) Main view

- ⑦ **Manual** : Displays whether manual control mode is enabled. You can change the mode.
  - To change the mode, click the checkbox. The checkmark indicates manual mode.
  - To return to auto control mode, clear the checkbox.
- ⑧ **Description** : Displays output device names.
- ⑨ **On/Off** : Displays current values and changed values (painted in light blue).
  - Clicking this field reverses the output status.
  - If the password (level 2) has not been entered, you need to enter it.
  - The password is valid until you exits from this submenu.
  - If change is not allowed, the item is painted in red.
  - Outputs for which active ON/OFF control is prohibited (main relay, etc) are defined for the system.
- ⑩ **Notes** : Field for notes.

## 3) Screen Shift sub-window

This sub-window appears when you make any changes on the screen in manual control mode.

- ⑪ **Yes** : Returns to auto control mode.
- ⑫ **No** : Keeps values in manual mode.

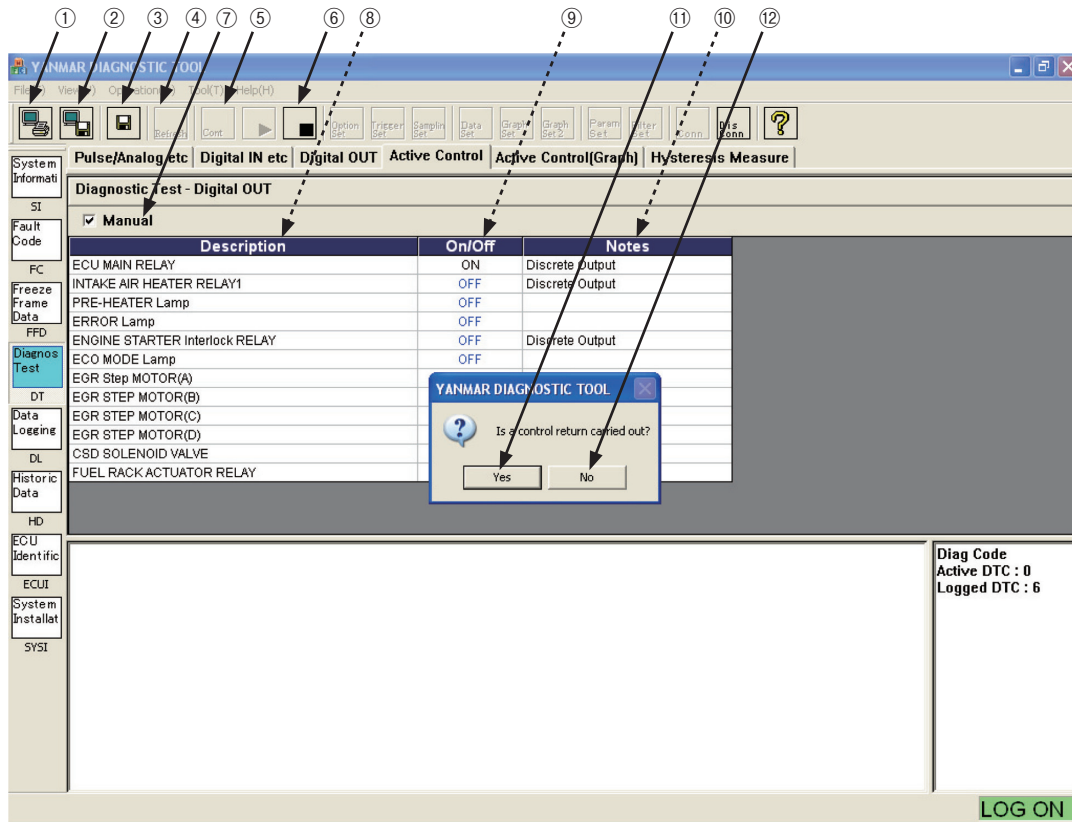





Figure 7-9 [Diagnostic Test] - [Digital Output Test] Screen

## 7.4.4 Active Control [Mechanic Function]

The functions in this screen are used to check feedback control (rack position control, speed governing control, etc) and auto calibration (idle rack position, etc) and measurement. They are categorized into 2 groups : functions available only when the engine is stopped, and functions available only when the clutch is in neutral and the engine is running. You can select and execute each function by clicking the corresponding "Current Value" value.

### 1) Operation tool bar

- ①  : Prints a hardcopy of the screen.
- ②  : Saves the screen in BMP format.
- ③  : Saves data on the screen in a CSV file.

### 2) Main view

- ④ **Manual** : The checkmark, which appears when active control operation is performed, indicates that auto control is stopped.
- ⑤ **Description** : Control item name
- ⑥ **Condition** : Indicates whether the engine must be running. "STOP" indicates that the item cannot be executed while the engine is running. "RUN" indicates that the engine must be running.
- ⑦ **Measured** : Shows a measured value (feedback value).
- ⑧ **Desired** : Shows the current setting value (desired value). Clicking the field opens a sub-window for you to change the value.
- ⑨ **Unit** : Unit.

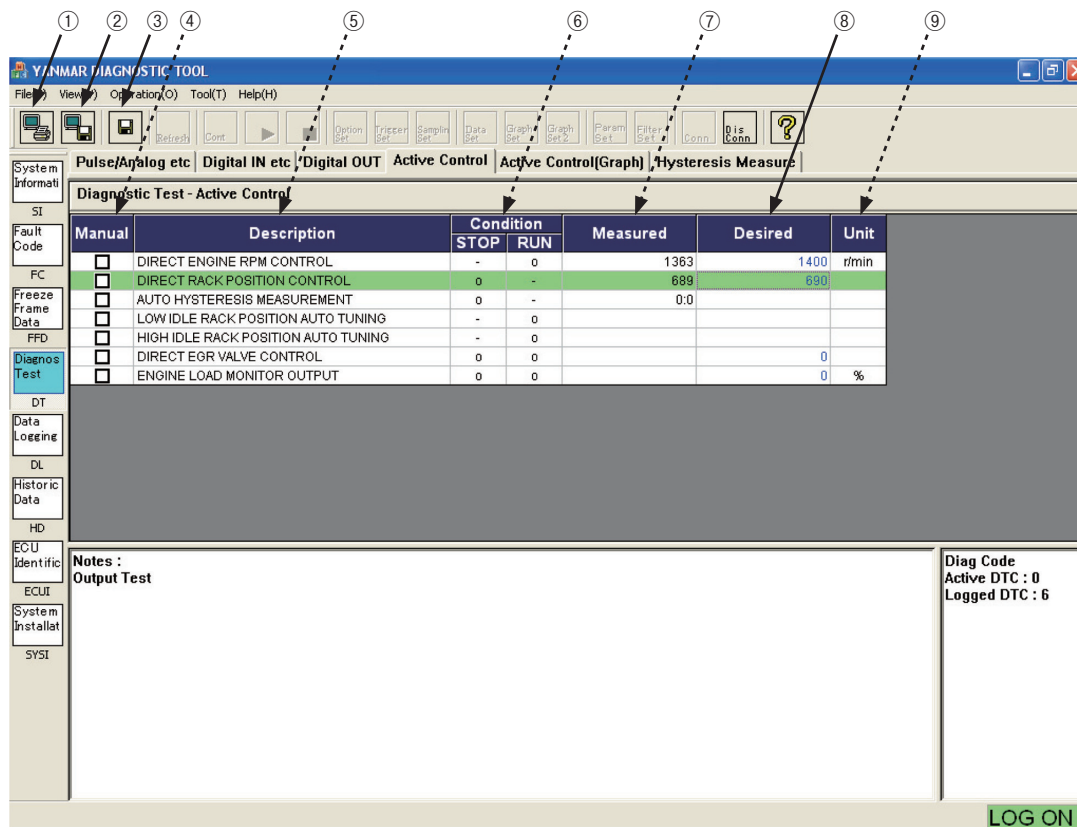

The screenshot shows the 'Diagnostic Test - Active Control' screen in the YJNMAR DIAGNOSTIC TOOL. The interface includes a menu bar (File, View, Operation(O), Tool(T), Help(H)), a toolbar with icons for print, save, data export, and other functions, and a main table with columns for Manual, Description, Condition (STOP/RUN), Measured, Desired, and Unit. A 'LOG ON' button is visible at the bottom right.

Manual	Description	Condition		Measured	Desired	Unit
		STOP	RUN			
<input type="checkbox"/>	DIRECT ENGINE RPM CONTROL	-	0	1363	1400	r/min
<input checked="" type="checkbox"/>	DIRECT RACK POSITION CONTROL	0	-	689	690	
<input type="checkbox"/>	AUTO HYSTERESIS MEASUREMENT	0	-	0.0		
<input type="checkbox"/>	LOW IDLE RACK POSITION AUTO TUNING	-	0			
<input type="checkbox"/>	HIGH IDLE RACK POSITION AUTO TUNING	-	0			
<input type="checkbox"/>	DIRECT EGR VALVE CONTROL	0	0		0	
<input type="checkbox"/>	ENGINE LOAD MONITOR OUTPUT	0	0		0	%

Notes :  
Output Test

Diag Code  
Active DTC : 0  
Logged DTC : 6

LOG ON

Figure 7-10 [Diagnostic Test] - [Active Control] Screen

## 3) Data Set sub-window

- ① **Data Name** : Shows the name of an item for which active control is enabled.
- ② **Measured** : Displays the current measured value of the feedback item.
- ③ **Max** : Shows the maximum value that can be set for the desired value.
- ④ **Desired** : Shows the current setting value (desired value).
- ⑤ **Min** : Shows the minimum value that can be set for the desired value.
- ⑥ **Note** : Note.
- ⑦ ▲ / ▼ : Increases/decreases the setting value with one of the factors : 1, 10, or 100.
- ⑧ **Default** : Restores the factory settings.
- ⑨ **Reception Mode** : Selects whether to receive feedback data.
- ⑩ ▲ / ▼ : Increases/decreases the Receiving Time value.
- ⑪ **Set** : Outputs the set data to the ECU.
- ⑫ **Close** : Cancels the set data and closes the sub-window.

- To control the selected item manually, increase/decrease the current value with the UP/DOWN buttons and press the Set button.
- When graph display mode is selected, you can receive feedback data at the set time and view it on the graph screen. Note that, the data is meaningless when the auto tuning function is enabled.

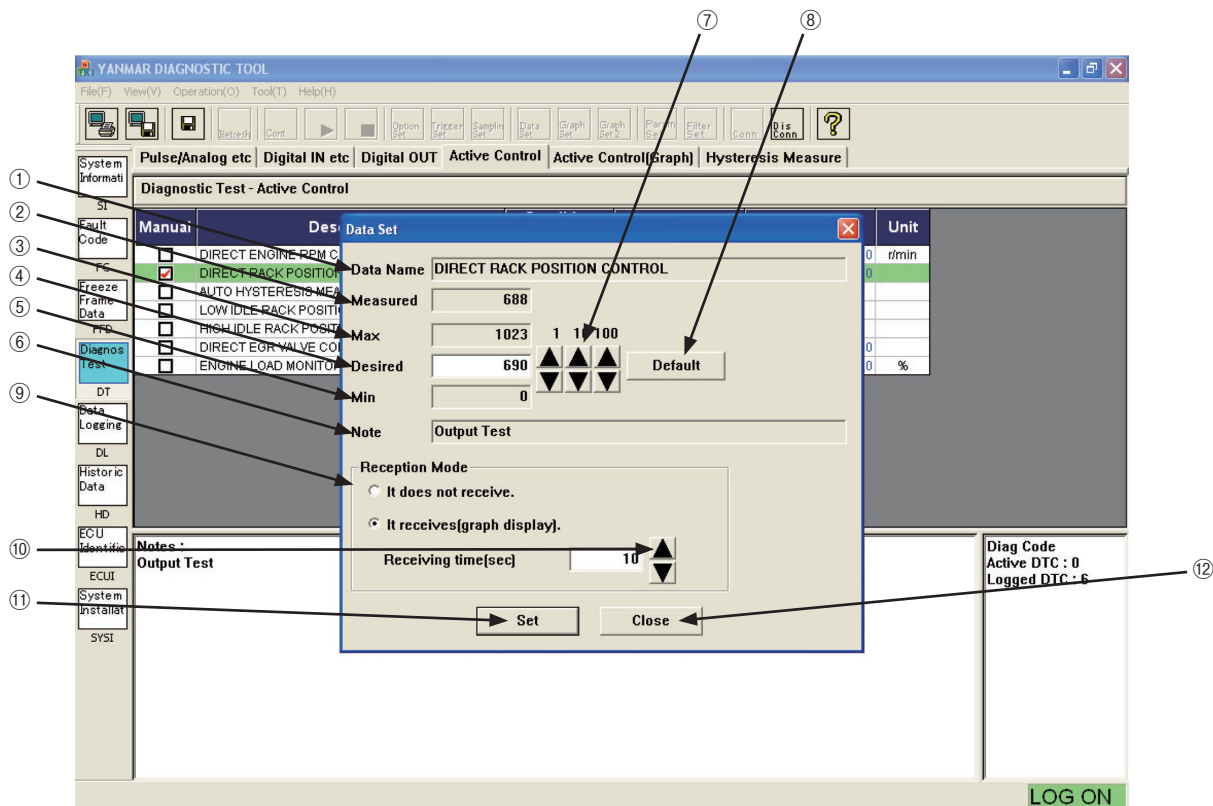

Figure 7-11 [Diagnostic Test] - [Active Control] - [Data Set] Sub-Window Screen

## 7.4.5 Active Control Graph

The graph is displayed only when you select "It receives [graph display]" of Reception Mode of Active Control.

### 1) Additional Information view (cursor value)

The data item name selected in graph setting operation and the value at the cursor position are displayed.

<Graph 1> : Cursor value of Graph Top.

① Position : Displays the data number at the cursor point.

② Displayed item and data : Displays an item name and data. The background color corresponds to the graph line color.

### 2) Operation tool bar

③  : Prints a hardcopy of the screen.

④  : Saves the screen in BMP format.

⑤  : Saves buffered data in a CSV file.

⑥  : Lets you specify displayed items and scaling for the top graph.

### 3) Main view

Displays graph 1. For information on operations related to graphs, see Chapter 8.

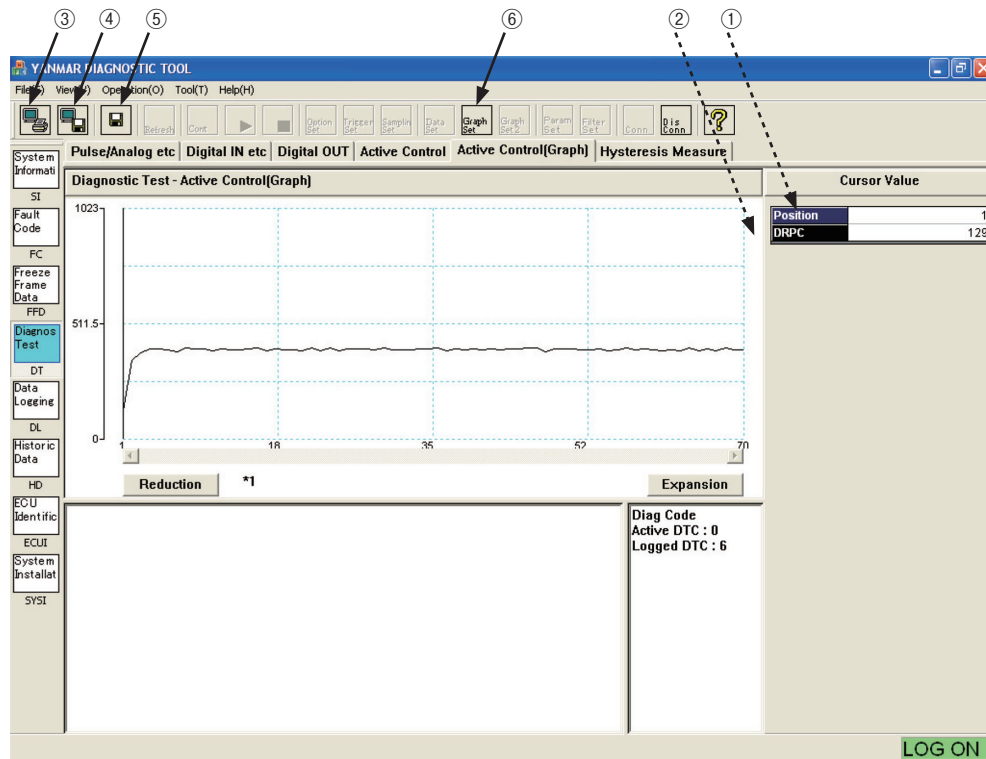

Figure 7-12 [Diagnostic Test] - [Active Control Graph] Screen





## 7.4.6 Hysteresis Measure (Graph Display)

The following functions are enabled by acquiring data from the ECU when you execute AUTO HYSTERESIS MEASUREMENT of Active Control.

### 1) Additional Information view (data display)

- ① **Cursor Data** :  
Displays data at the cursor point. (only on the trend graph screen)
- ② **Measure Data** :  
Not supported now. 0 is displayed.
- ③ **Setting Data** :  
Preset points used for hysteresis evaluation computation. The system setting file is loaded and used with the pass/fail criteria for measurement results.
- ④ **Result** :  
Not supported now. 0 is displayed.
- ⑤ **X-Y** , **Trend** :  
You can select <X-Y> graph (X axis : electric current value) or <Trend> graph (X axis : time) by clicking the corresponding button.

### 2) Operation tool bar

- ⑥  : Prints a hardcopy of the screen.
- ⑦  : Saves the screen in BMP format.
- ⑧  : Saves the measured result in a CSV file.
  - date\_time\_DTHY.CSV : Raw data of the X-Y graph
  - date\_time\_DTHYC.CSV : Point data (Im1 to 8) and computation result
- ⑨  : Lets you set the scaling for the X-Y plot graph.

### 3) Main view

The graph of raw data is displayed in the upper part.

< X-Y graph > : The graph is displayed with the alternative value of the rack actuator electric current (pulse duty value) on the X axis and the alternative value of the rack position (digital encode value of voltage) on the Y axis. The values of the rack positions when the X-axis value increases and it decreases are superimposed so that you can see the hysteresis intuitively. In general, the Y-axis value changes along the lower line when the X-axis value increases and along the upper line when the X-axis value decreases.

The  function is available.

For information on operations related to graphs, see Chapter 8.

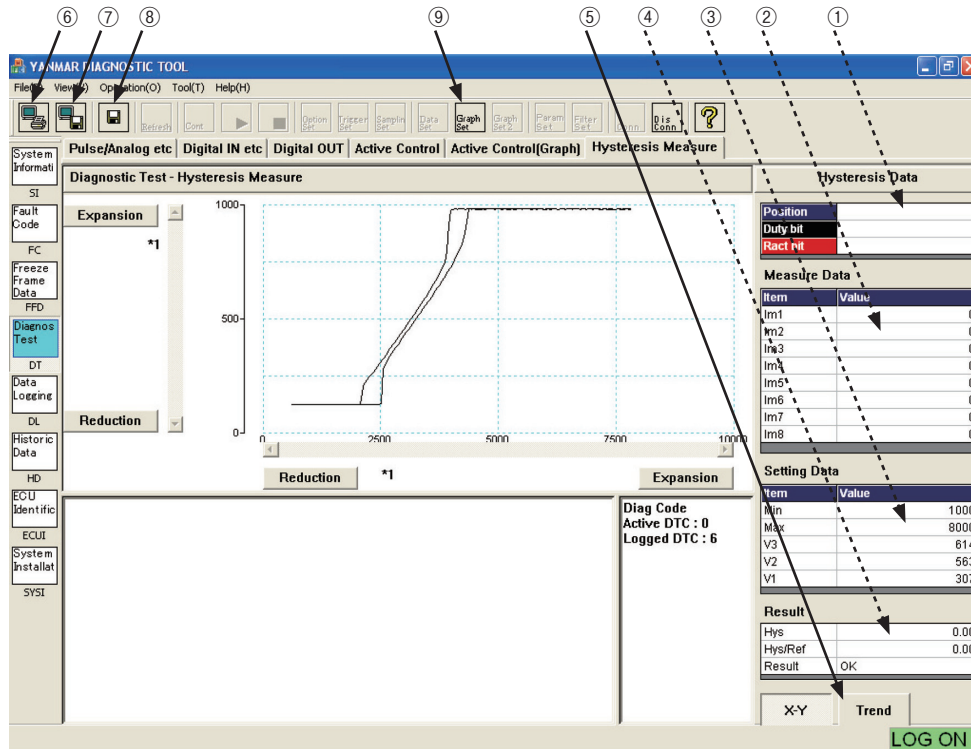

Figure 7-13 [Diagnostic Test] - [Hysteresis Measure] - [X-Y] Screen

< Trend graph > : The graph is displayed with the time (0.1 second/point) on the X axis and with the alternative value of the rack position (digital encode value of voltage) and the alternative value of the rack actuator electric current (pulse duty value) on the Y axis. You can see the deviation of the rack position relative to the electric current value (duty).

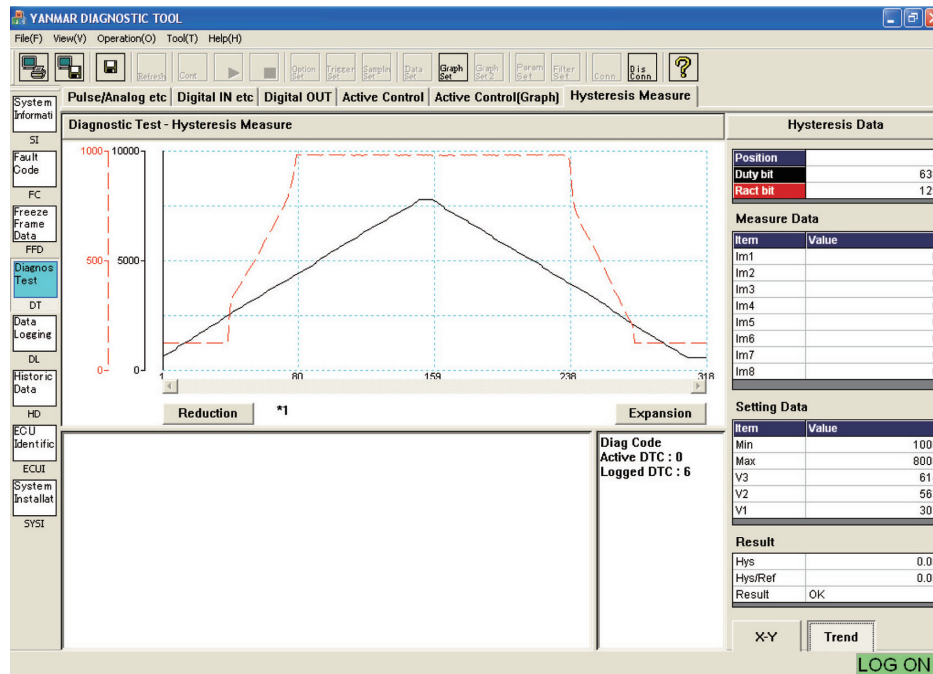

Figure 7-14 [Diagnostic Test] - [Hysteresis Measure] - [Trend] Screen









## 7.5 Data Logging 【Mechanic Function】

This tool lets you perform troubleshooting and analyze running status while operating the engine. You can select a submenu from : Data Monitor that displays logged data in real time, Stored Data that displays stored data, and Trend Graph that shows data in graphic format. Logging data consists of FFD and data at 8 points you can set freely. The trigger setting function is provided to facilitate saving data.

### 7.5.1 Data Monitor

This function receives and displays measured data and control information of ECU's sensor at preset sampling intervals (minimum : 0.1 second). You can set the trigger function to start storing data.

#### 1) Operation tool bar

- ①  : Prints a hardcopy of the screen.
- ②  : Saves the screen in BMP format.
- ③  : Starts receiving data. (Data that has not been saved in "7.5.2 Stored Data" is overwritten and deleted.)
- ④  : Stops receiving data manually.
- ⑤  : Sets data to be received. Clicking this button opens the Data Set sub-window, which lets you make changes (up to 10 points).
- ⑥  : Lets you set option data. Clicking this button opens the Option Data Set sub-window, which lets you make changes.
- ⑦  : Sets the trigger conditions (trigger ON/OFF, data selection, level selection, and trigger type), the number of delay points, and the number of stored data points. Clicking this button opens the Trigger Setting sub-window, which lets you make changes.
- ⑧  : Sets the sampling frequency. Clicking this button opens the Sampling Setting sub-window, which lets you make changes.

#### 2) Main view

- ⑨ **Description** : Displays a data name to be logged.
- ⑩ **Value** : Displays the measured value.
- ⑪ **Unit** : Unit.
- ⑫ **Notes** : Field for notes.

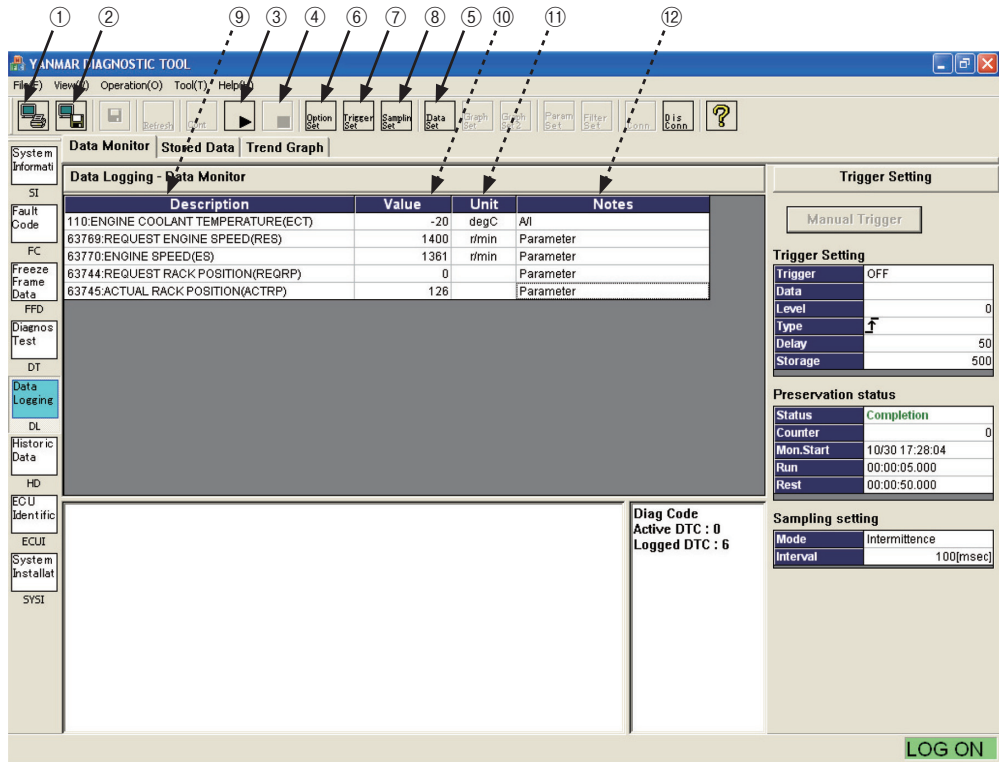

Figure 7-15 [Data Logging] - [Data Monitor] Screen

## 3) Additional Information view

## (i) Trigger Setting

Displays trigger setting information.

- ① **Manual Trigger** : Lets you generate a trigger manually.
- ② **Trigger** : Displays the trigger setting status.
- ③ **Data** : Displays the acronym of data for which a trigger is set.
- ④ **Level** : Displays the threshold value of the trigger setting.
- ⑤ **Type** : Displays the type of the set trigger (rising edge or falling edge).
- ⑥ **Delay** : Shows the number of data points between the start of storage and the trigger.
- ⑦ **Storage** : Shows the number of data points to be stored (a single point means a set of data items at a certain point of time).

## (ii) Preservation status

Displays the data logging status.

- ⑧ **Status** : Displays the status : "Display" during waiting for a trigger, "Preservation" during storing data, or "Completion" at the completion of measurement.
- ⑨ **Counter** : Displays the number of acquired data points.
- ⑩ **Mon. Start** : Displays the time when monitoring starts.
- ⑪ **Run** : Displays the elapsed time from the start of measurement.
- ⑫ **Rest** : Displays the remaining time until the end of measurement.

## (iii) Sampling setting

Displays the sampling setting status.

- ⑬ **Mode** : Displays "Intermittence" when the sampling frequency setting is 100 msec or "Polling" for other settings.
- ⑭ **Interval** : Displays the sampling frequency.

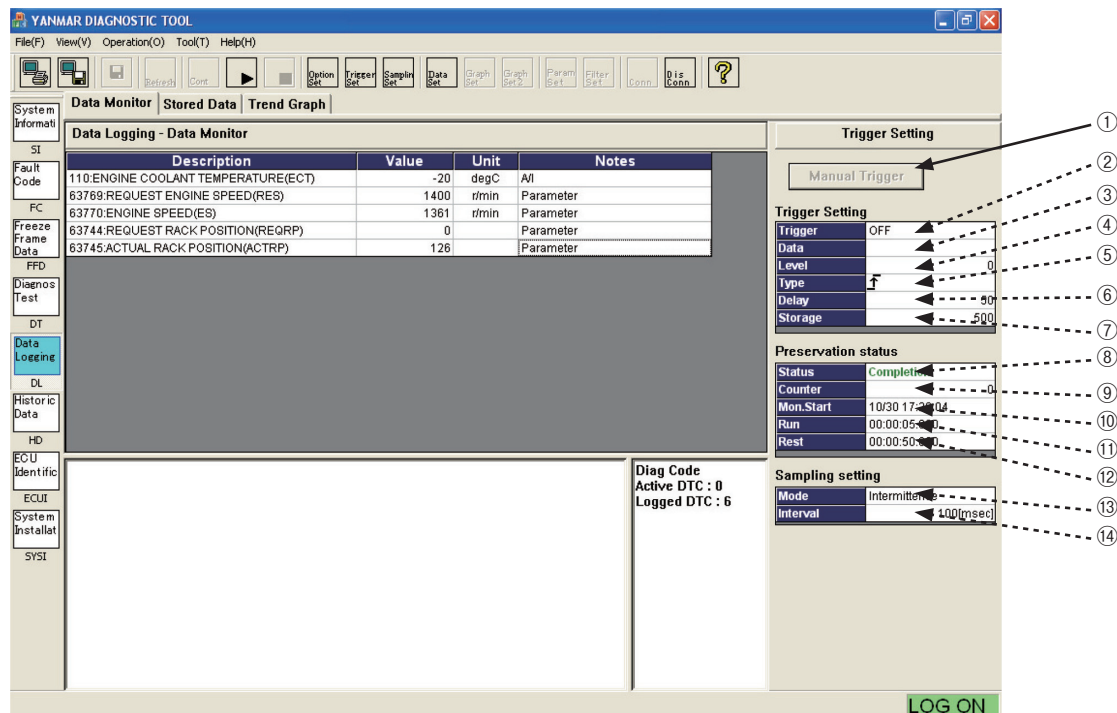



Figure 7-16 [Data Logging] - [Data Monitor] Screen



4) [Data Set] sub-window

This function lets you set data items to be displayed and the display order freely. To use this function, click the  button on the Operation tool bar. You can select and register 10 points of data freely from data pieces categorized and pre-registered in addition to FFD. For more information on using this function, see 7.3.1- 5).

5) [Option Data Set] sub-window

You can select and register 8 points of data freely from data pieces categorized and pre-registered in addition to FFD. The number of data points is limited to 8. Therefore, if you want to add an item, you must give up another item.

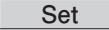
Clicking the  button on the Operation tool bar enables the setting operation.

- ① "DATA" : Displays the list of data items that can be displayed.
- ② ◀ / ▶ : Selects/deselects a data item to be displayed.
- ③ "Set Data" : Data items displayed in the Main view.
- ④  : Sets the entered information.
- ⑤  : Cancels the entered information.

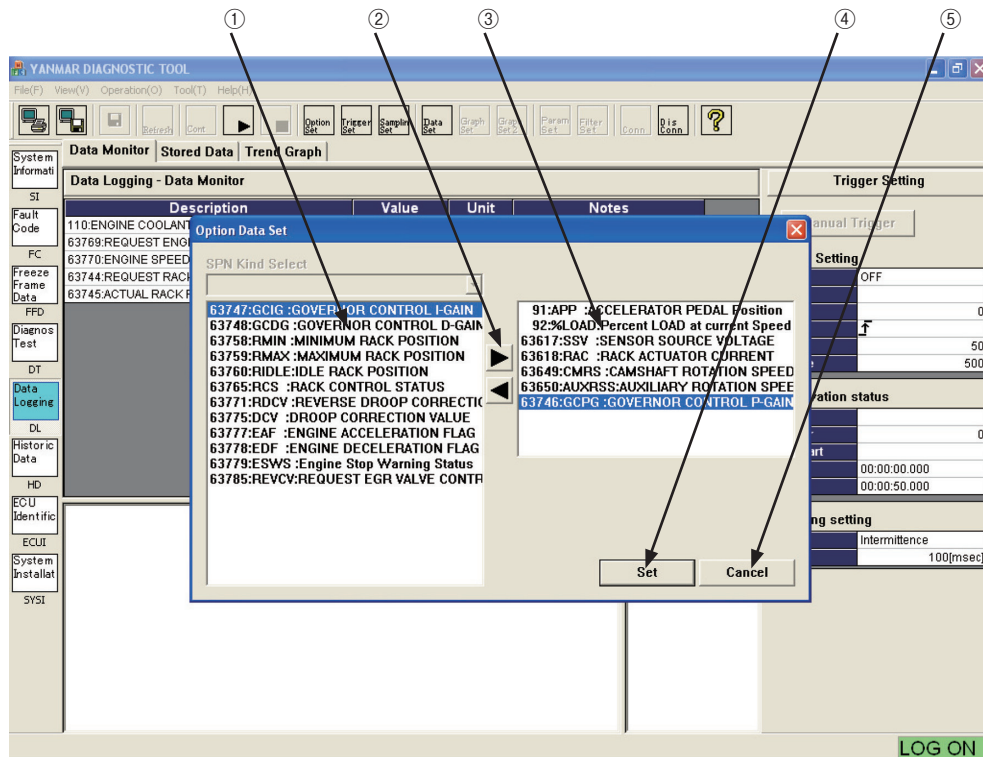

Figure 7-17 [Data Logging] - [Data Monitor] - [Option Data Set] Sub-Window

## 6) Trigger Setting sub-window

Clicking the  button on the Operation tool bar enables the trigger setting operation.

- ① **Trigger (ON)** : Sets whether to enable the trigger.
- ② **Data Select** : Selects data to which the trigger is applied.
- ③ **Level** : Sets the threshold value of the trigger.
- ④ **Type** : Sets the type of the trigger (rising edge or falling edge).
- ⑤ **Delay** : Shows the number of data points between the start of storage and the trigger.
- ⑥ **Storage** : Sets the number of data points to be stored. (A single point means a set of data items at a certain point of time.)
- ⑦ **Set** : Sets the entered information.
- ⑧ **Cancel** : Cancels the entered information.

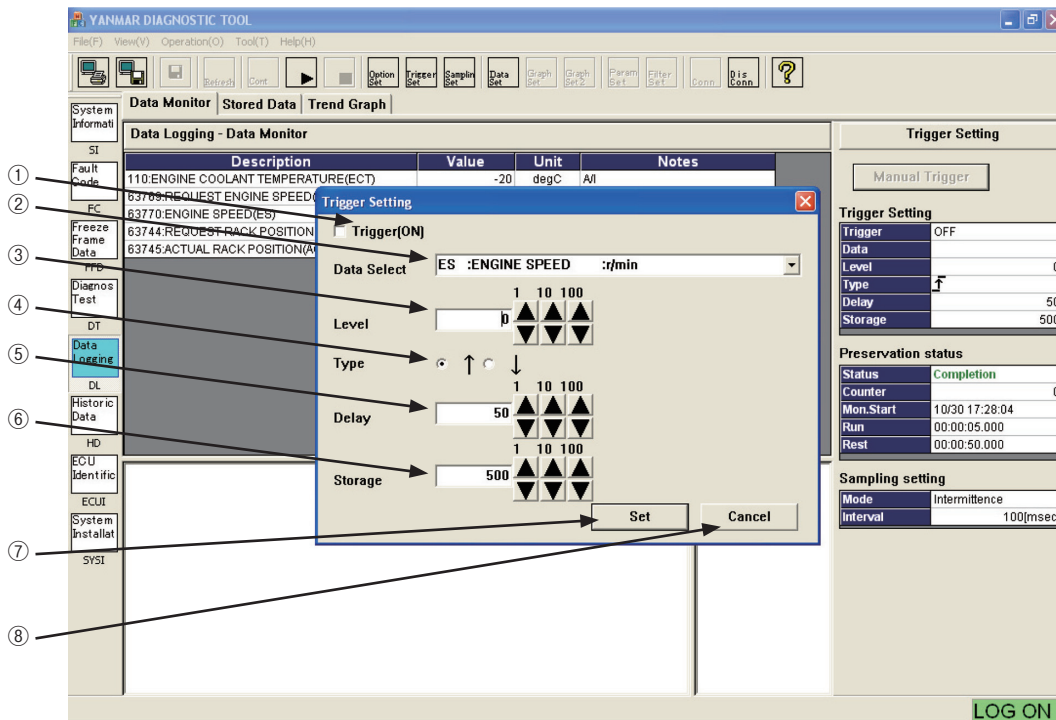



Figure 7-18 [Data Logging] - [Data Monitor] - [Trigger Setting] Sub-Window Screen

## 7) Sampling Setting sub-window

Clicking the  button on the Operation tool bar enables the sampling frequency setting operation.

- ① **Select** : Select a sampling frequency by checkmarking one of the buttons.
- ②  /  : These buttons are available when you select the radio button that lets you enter any value. You can increase/decrease the sampling frequency in steps of 1, 10, or 100.
- ③ **Unit** : Select a unit.
- ④ **Set** : Sets the entered information.
- ⑤ **CANCEL** : Cancels the entered information..

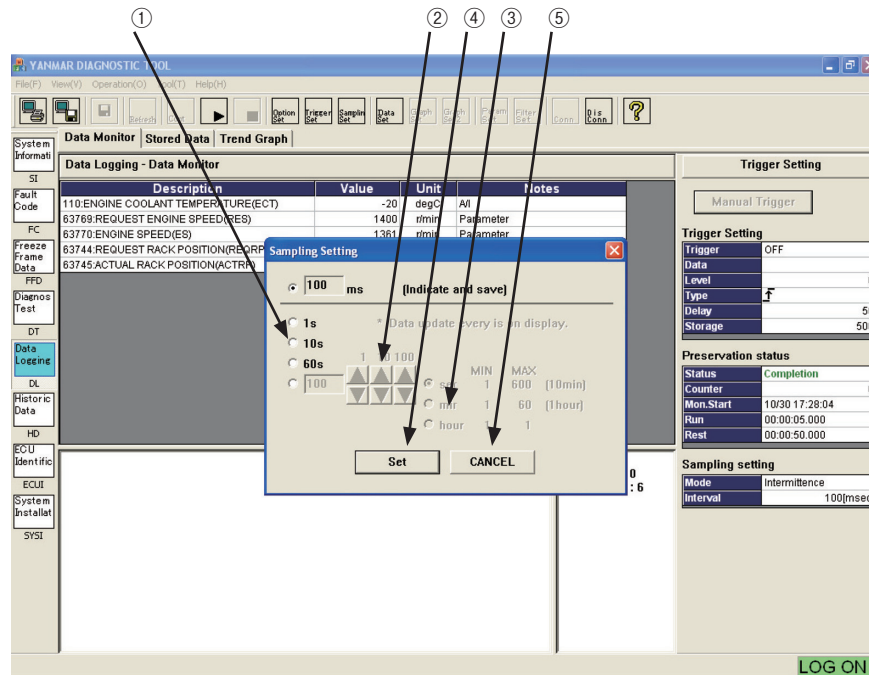



Figure 7-19 [Data Logging] - [Data Monitor] - [Sampling Setting] Sub-Window Screen





## 8) Overview of data sampling operation

- ① Set item names you want to display. .... 4)、5)
- ② Set the trigger conditions as necessary. (If you do not set them, you can forcibly start recording by clicking the Manual Trigger button.) .....6)
- ③  Click. ....1) ③
- ④ When a trigger is generated (or the Manual Trigger button is clicked), Preservation is displayed in the Status field of "Preservation status." .....4) ⑧
- ⑤ When you click  to stop receiving data manually or the buffer becomes full, Completion is displayed in the Status field of "Preservation status" and the reception stops.
- ⑥ As necessary, you can check the graph or save data in a file.

## 7.5.2 Stored Data

You can display values of received data, and check and save them. You cannot select this item during receiving data. Note that, if you stop the operation without a trigger, no item is displayed because no data is stored.

### 1) Operation tool bar

- ①  : Prints a hardcopy of the screen.
- ②  : Saves the screen in BMP format.
- ③  : Saves buffered data in a CSV file.
- ④  : Opens a sub-window to set displayed items of received data and the order. For information on the settings, see 3.7.1-5).

### 2) Main view

- ⑤ **No.** : Shows the chronological ordinal number of data.
- ⑥ **Time** : Displays the time axis data.
- ⑦ **Item** : Displays the acronym of the specified data names (you can check the details such as name and unit on the ECU Identification screen). You can select the display format (decimal/hexadecimal) by right-clicking the item field.

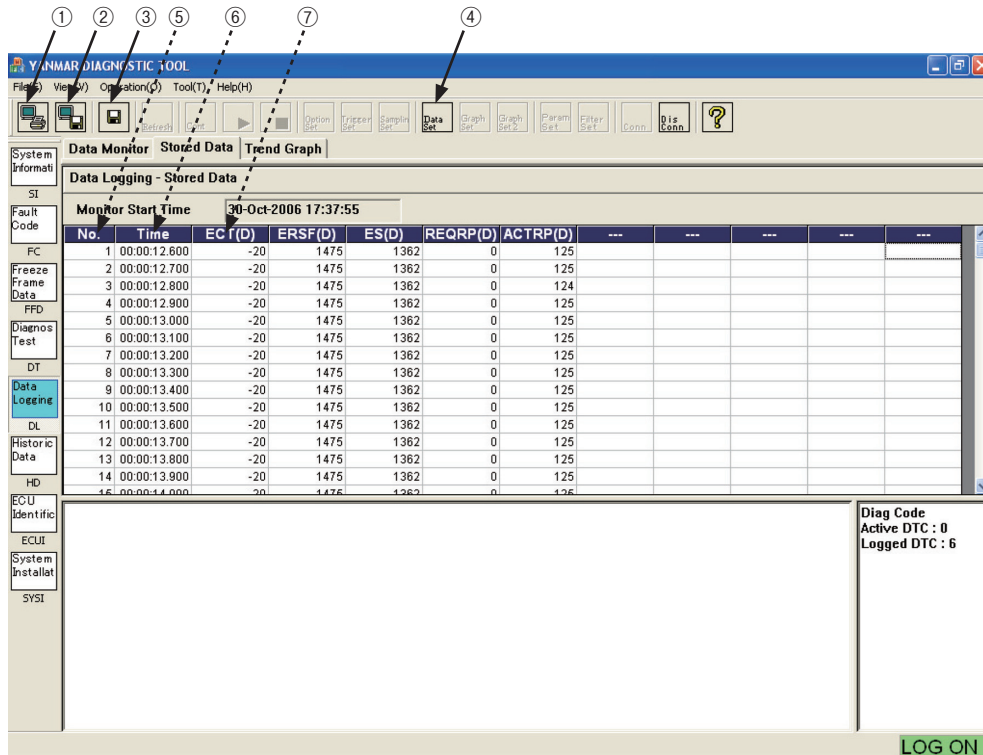

The screenshot shows the 'Data Logging - Stored Data' screen in the YINMAR DIAGNOSTIC TOOL. The interface includes a menu bar (File, View, Operation, Tool, Help) and a toolbar with icons for print, save, and data set. The main data table is titled 'Data Logging - Stored Data' and has a 'Monitor Start Time' of 30-Oct-2006 17:37:55. The table columns are No., Time, EC (D), ERSF (D), ES (D), REQRP (D), and ACTRP (D). The 'Data Logging' button in the left sidebar is highlighted. A 'LOG ON' button is visible at the bottom right.

No.	Time	EC (D)	ERSF (D)	ES (D)	REQRP (D)	ACTRP (D)	---	---	---	---
1	00:00:12.600	-20	1475	1362	0	125				
2	00:00:12.700	-20	1475	1362	0	125				
3	00:00:12.800	-20	1475	1362	0	124				
4	00:00:12.900	-20	1475	1362	0	125				
5	00:00:13.000	-20	1475	1362	0	125				
6	00:00:13.100	-20	1475	1362	0	125				
7	00:00:13.200	-20	1475	1362	0	125				
8	00:00:13.300	-20	1475	1362	0	125				
9	00:00:13.400	-20	1475	1362	0	125				
10	00:00:13.500	-20	1475	1362	0	125				
11	00:00:13.600	-20	1475	1362	0	125				
12	00:00:13.700	-20	1475	1362	0	125				
13	00:00:13.800	-20	1475	1362	0	125				
14	00:00:13.900	-20	1475	1362	0	125				
15	00:00:14.000	-20	1475	1362	0	125				

Figure 7-20 [Data Logging] - [Stored Data] Screen

### 7.5.3 Trend Graph [Mechanic Function]

This function is used to display data during reception and stored data in graphic format. By grouping data items in advance, you can superimpose related items in graphic format. Digital information can be displayed as 1/0 graph by specifying the data bit position. The graph during data reception is automatically appended and plotted.

#### 1) Additional Information view (cursor value)

The data item names selected in graph setting operation and the values at the cursor position are displayed.

<Graph 1> : Cursor values of Graph Top. < Graph 2> : Cursor values of Graph Bottom.

① **Position** : Displays the data number of the cursor point.

② **Time** : Displays the time of the cursor point.

③ **Unit** : Displays the time unit.

④ Displayed item and data Displays an item name and data. The background color corresponds to the graph line color.

#### 2) Operation tool bar

⑤  : Prints a hardcopy of the screen.

⑥  : Saves the screen in BMP format.

⑦  : Starts data reception. (Data that has not been saved in "7.5.2 Stored Data" is overwritten and deleted.)

⑧  : Lets you specify displayed items and scaling for the top graph.

⑨  : Lets you specify displayed items and scaling for the bottom graph.

• For more information on the settings related to graphs, see Chapter 8.

#### 3) Main view

Displays graph 1 and graph 2. For information on operations related to graphs, see Chapter 8.

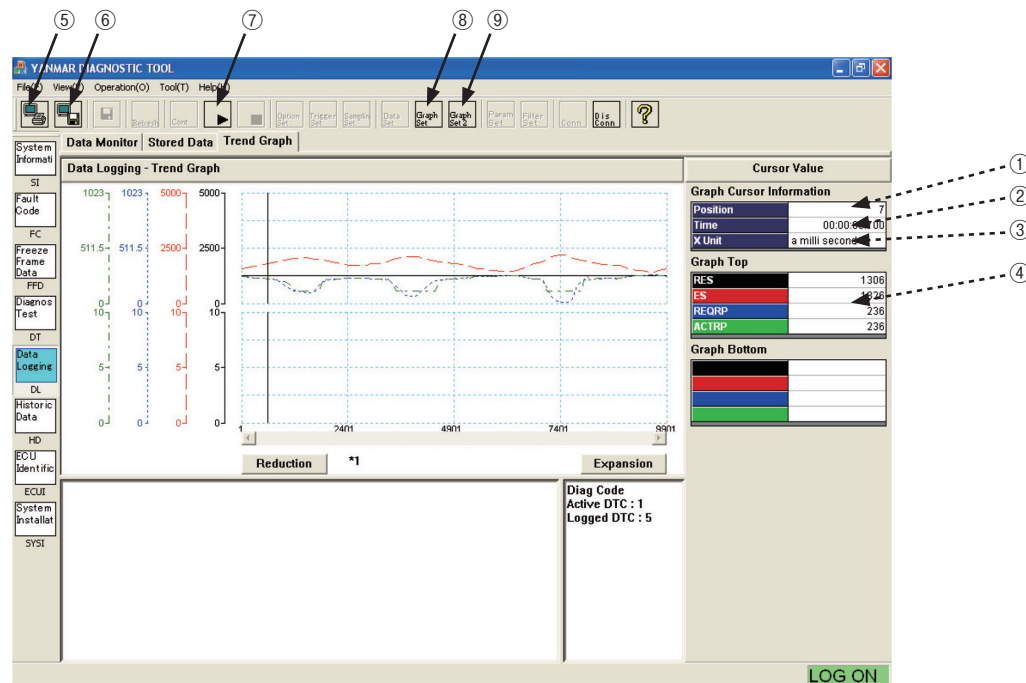

Figure 7-21 [Data Logging] - [Trend Graph]





## 7.6 Historical Data

This function is used to display the operation/maintenance information of the engine stored in the ECU. It consists of the Lifetime Data and RPM-Load Profile submenus.

### 7.6.1 Lifetime Data [Universal Function]

You can check total cumulative operation time and operation time in delayed status, and clear trip time.

#### 1) Operation tool bar

- ①  : Prints a hardcopy of the screen.
- ②  : Saves the screen in BMP format.
- ③  : Saves all historical data in CSV format.
- ④  : Refreshes all historical data.

#### 2) Function buttons

- ⑤ **Clear Trip Time** : Deletes data for which the "Clear" field is checked. When you click the **Clear Trip Time** button, your password is asked.

#### 3) Main view

- ⑥ **Clear** : Field to select an item to be deleted. (Click to checkmark it.)
- ⑦ **Description** : Description of stored data.
- ⑧ **Hours** : Displays cumulative time.

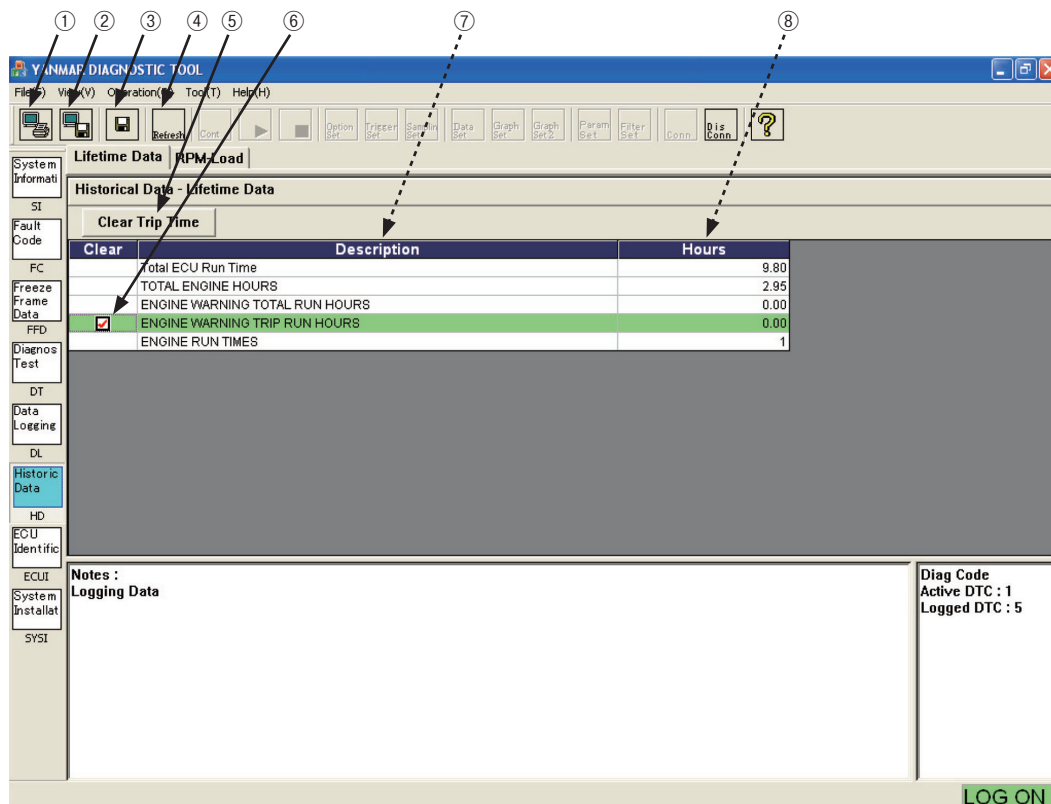







Figure 7-22 [Historical Data] - [Lifetime Data] Screen

## 7.6.2 RPM-Load Profile [Mechanic Function]

This function displays the histogram of the load percentage frequencies for rpm ranges to express the running status visually. You cannot delete the lifetime data.

### 1) Operation tool bar

- ①  : Prints a hardcopy of the screen.
- ②  : Saves the screen in BMP format.
- ③  : Saves all historical data in CSV format.
- ④  : Refreshes data.
- ⑤  : Opens the Graph Scale Set sub-window. You can adjust the full scale of each axis in 3 steps (25, 50, or 100%).

### 2) Main view

- ⑥ **Data** : Cumulative running time for each load and rpm range.
- ⑦ **Total** : Total running time of each row (column).
- ⑧ **(%)** : Percentage of each row (column) to the overall total running time.
- ⑨ **Bar graph** filed : Bar graph relative to the full scale of each axis

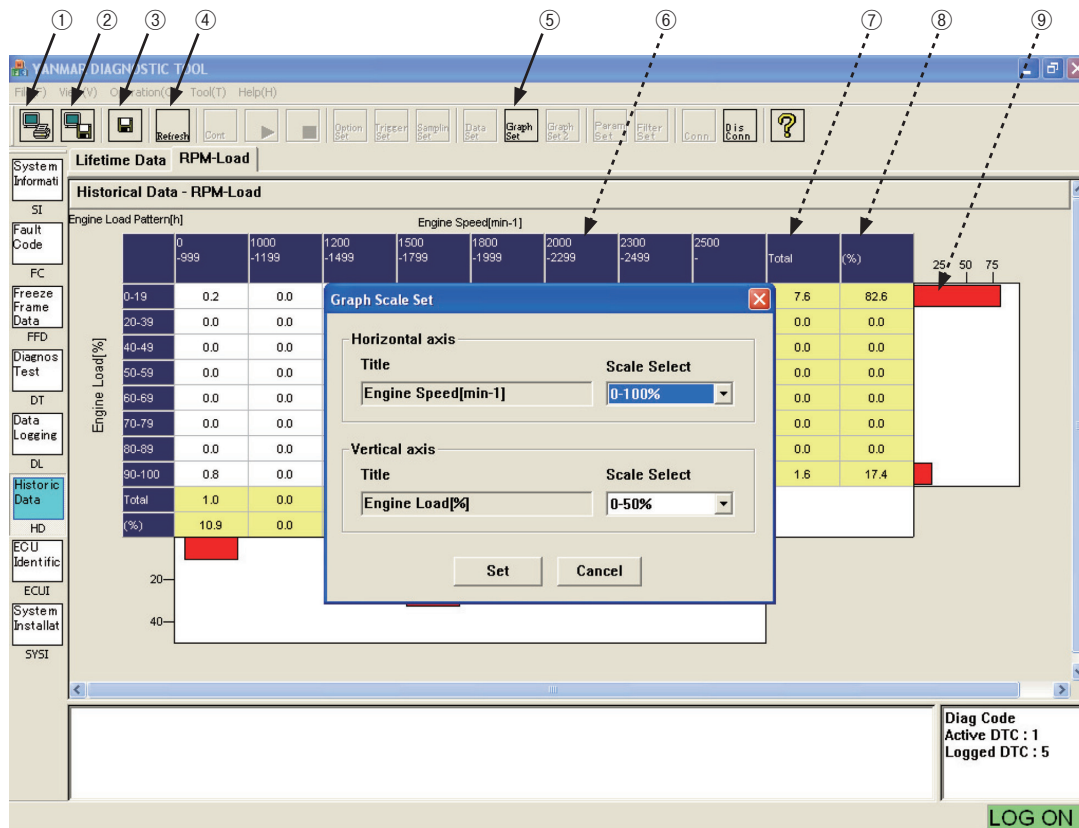

Figure 7-23 [Historical Data] - [RPM-Load Profile] Screen



## 7.7 ECU Identification [Mechanic Function]

This function is used to display engine system/ECU's ID information, and ECU I/O channel assignment information. A level-2 password is required to display the data.

### 7.7.1 Analog Channels

This screen displays the analog signal information including the channel assignment, unit, scaling, etc.

#### 1) Operation tool bar

- ①  : Prints a hardcopy of the screen.
- ②  : Saves the screen in BMP format.

#### 2) Main view

- ③ **LID** : Data management number called local ID.
- ④ **CID (SPN)** : Parameter ID number complying with SAE J1939. Used as a common ID.
- ⑤ **Description** : Description of the sensor, signal, etc.
- ⑥ **Acronym** : Acronym (complying with the SAE standard)
- ⑦ **Size** : Data length.
- ⑧ **Resolution** : Resolution.
- ⑨ **Offset** : Offset.
- ⑩ **Unit** : Unit.
- ⑪ **Range** : Range.

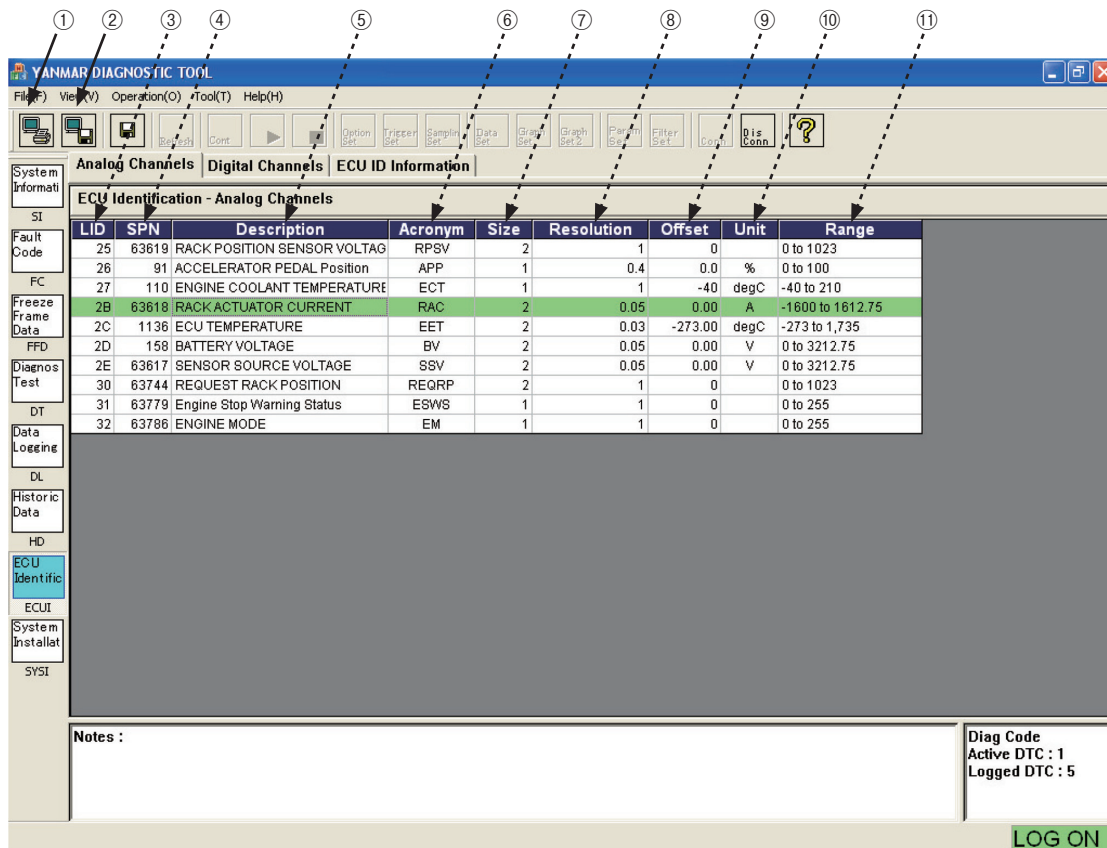

The screenshot shows the 'YANMAR DIAGNOSTIC TOOL' window with the 'ECU ID Information' tab selected. The 'Analog Channels' sub-tab is active, displaying a table of sensor data. The table has columns for LID, SPN, Description, Acronym, Size, Resolution, Offset, Unit, and Range. A 'Notes' section at the bottom right indicates 'Active DTC : 1' and 'Logged DTC : 5'. A 'LOG ON' button is visible at the bottom right of the window.

LID	SPN	Description	Acronym	Size	Resolution	Offset	Unit	Range
25	63619	RACK POSITION SENSOR VOLTAGE	RPSV	2	1	0		0 to 1023
26	91	ACCELERATOR PEDAL Position	APP	1	1	0.4	%	0 to 100
27	110	ENGINE COOLANT TEMPERATURE	ECT	1	1	-40	degC	-40 to 210
2B	63618	RACK ACTUATOR CURRENT	RAC	2	0.05	0.00	A	-1600 to 1612.75
2C	1136	ECU TEMPERATURE	EET	2	0.03	-273.00	degC	-273 to 1,735
2D	158	BATTERY VOLTAGE	BV	2	0.05	0.00	V	0 to 3212.75
2E	63617	SENSOR SOURCE VOLTAGE	SSV	2	0.05	0.00	V	0 to 3212.75
30	63744	REQUEST RACK POSITION	REQRP	2	1	0		0 to 1023
31	63779	Engine Stop Warning Status	ESWS	1	1	0		0 to 255
32	63786	ENGINE MODE	EM	1	1	0		0 to 255

Notes :  
 Active DTC : 1  
 Logged DTC : 5



LOG ON

Figure 7-24 [ECU Identification] - [Analog Channels] Screen

## 7.7.2 Digital Channels 【Mechanic Function】

This screen displays the information of the contact input/output signals including the channel assignment and logic. For outputs, it also displays whether active output is allowed.

### 1) Operation tool bar

- ①  : Prints a hardcopy of the screen.
- ②  : Saves the screen in BMP format.

### 2) Main view

- ③ **I/O** : Type of contact : input or output.
- ④ **LID** : Data management number called local ID.
- ⑤ **CID (SPN)** : Parameter ID number complying with SAE J1939.
- ⑥ **Description** : Description of the sensor, signal, etc.
- ⑦ **Acronym** : Acronym (complying with the SAE standard)
- ⑧ **Byte** : Byte position of data.
- ⑨ **Bit** : Bit position of data.
- ⑩ **Logic** : Whether logic is reversed or not.
- ⑪ **Mask** : Permission mask for active control (0 indicates that you cannot change the setting).

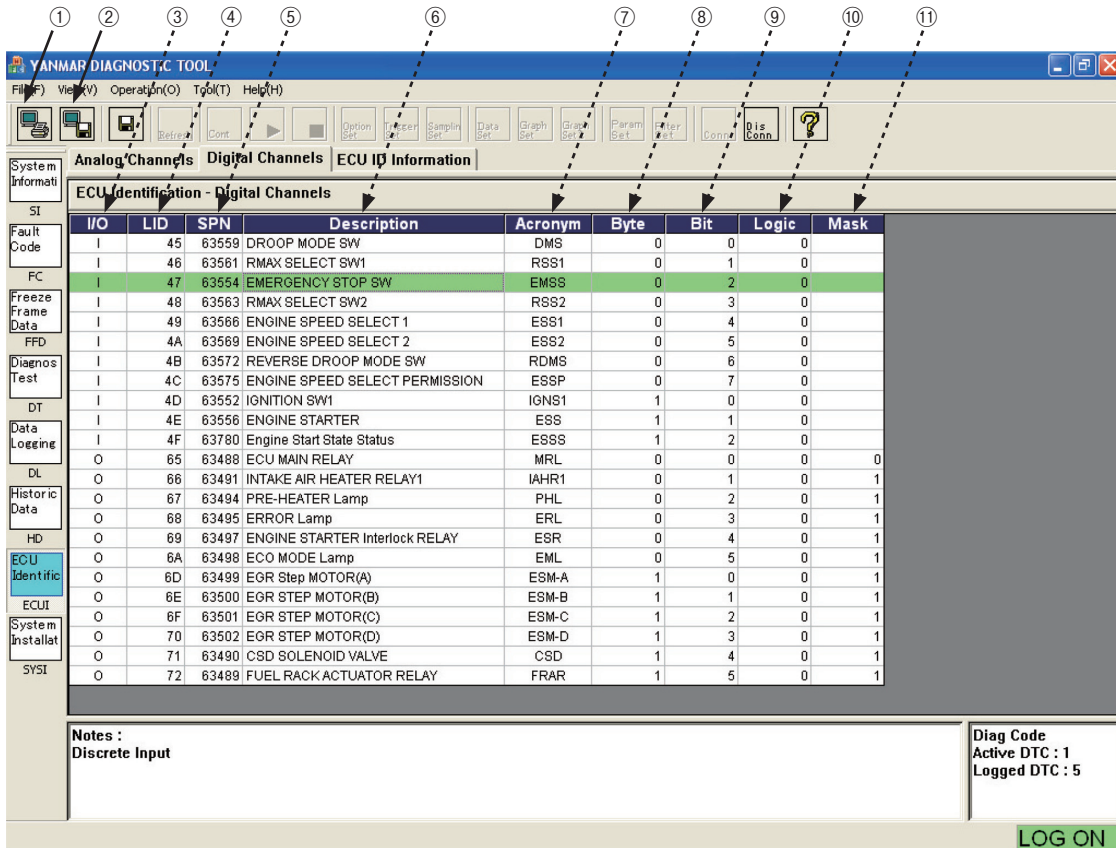

The screenshot shows the 'Digital Channels' screen in the YANMAR DIAGNOSTIC TOOL. The table below represents the data displayed in the main view:

I/O	LID	SPN	Description	Acronym	Byte	Bit	Logic	Mask
I	45	63559	DROOP MODE SW	DMS	0	0	0	0
I	46	63561	RMAX SELECT SW1	RSS1	0	1	0	0
I	47	63554	EMERGENCY STOP SW	EMSS	0	2	0	0
I	48	63563	RMAX SELECT SW2	RSS2	0	3	0	0
I	49	63566	ENGINE SPEED SELECT 1	ESS1	0	4	0	0
I	4A	63569	ENGINE SPEED SELECT 2	ESS2	0	5	0	0
I	4B	63572	REVERSE DROOP MODE SW	RDMS	0	6	0	0
I	4C	63575	ENGINE SPEED SELECT PERMISSION	ESSP	0	7	0	0
I	4D	63552	IGNITION SW1	IGNS1	1	0	0	0
I	4E	63556	ENGINE STARTER	ESS	1	1	0	0
I	4F	63780	Engine Start State Status	ESSS	1	2	0	0
O	65	63488	ECU MAIN RELAY	MRL	0	0	0	0
O	66	63491	INTAKE AIR HEATER RELAY1	IAHR1	0	1	0	1
O	67	63494	PRE-HEATER Lamp	PHL	0	2	0	1
O	68	63495	ERROR Lamp	ERL	0	3	0	1
O	69	63497	ENGINE STARTER Interlock RELAY	ESR	0	4	0	1
O	6A	63498	ECO MODE Lamp	EML	0	5	0	1
O	6D	63499	EGR Step MOTOR(A)	ESM-A	1	0	0	1
O	6E	63500	EGR STEP MOTOR(B)	ESM-B	1	1	0	1
O	6F	63501	EGR STEP MOTOR(C)	ESM-C	1	2	0	1
O	70	63502	EGR STEP MOTOR(D)	ESM-D	1	3	0	1
O	71	63490	CSD SOLENOID VALVE	CSD	1	4	0	1
O	72	63489	FUEL RACK ACTUATOR RELAY	FRAR	1	5	0	1

Notes: Discrete Input

Diag Code  
Active DTC : 1  
Logged DTC : 5



LOG ON

Figure 7-25 [ECU Identification] - [Analog Channels] Screen

### 7.7.3 ECU ID Information

This screen displays engine system/ECU's ID information.

#### 1) Operation tool bar

- ①  : Prints a hardcopy of the screen.
- ②  : Saves the screen in BMP format.

#### 2) Main view

- ③ **ECUID** : Data manage number stored in the ECU.
- ④ **CID** : Data management number called common ID.
- ⑤ **Description** : Name of displayed item.
- ⑥ **Value** : Value of item.
- ⑦ **Unit** : Unit.
- ⑧ **Notes** : Field for notes.

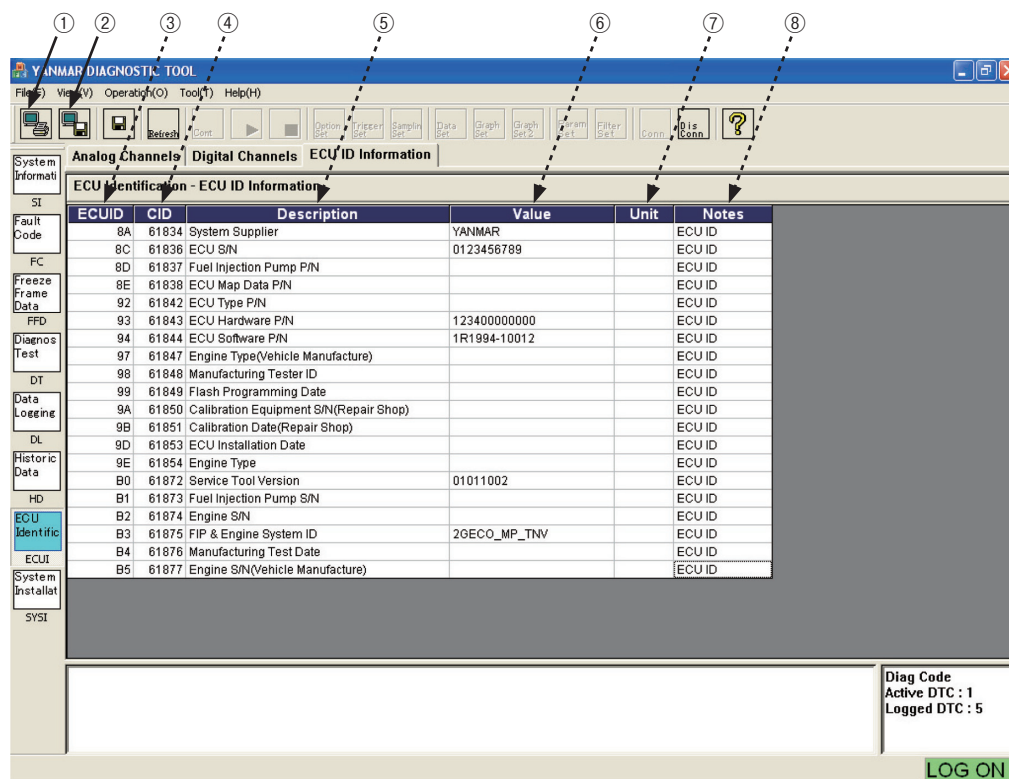

The screenshot shows the 'YANMAR DIAGNOSTIC TOOL' interface. The main window is titled 'ECU Identification - ECU ID Information'. It features a table with the following data:

ECUID	CID	Description	Value	Unit	Notes
8A	61834	System Supplier	YANMAR		ECU ID
8C	61836	ECU S/N	0123456789		ECU ID
8D	61837	Fuel Injection Pump P/N			ECU ID
8E	61838	ECU Map Data P/N			ECU ID
92	61842	ECU Type P/N			ECU ID
93	61843	ECU Hardware P/N	123400000000		ECU ID
94	61844	ECU Software P/N	1R1994-10012		ECU ID
97	61847	Engine Type(Vehicle Manufacture)			ECU ID
98	61848	Manufacturing Tester ID			ECU ID
99	61849	Flash Programming Date			ECU ID
9A	61850	Calibration Equipment S/N(Repair Shop)			ECU ID
9B	61851	Calibration Date(Repair Shop)			ECU ID
9D	61853	ECU Installation Date			ECU ID
9E	61854	Engine Type			ECU ID
B0	61872	Service Tool Version	01011002		ECU ID
B1	61873	Fuel Injection Pump S/N			ECU ID
B2	61874	Engine S/N			ECU ID
B3	61875	FIP & Engine System ID	2GECO_MP_TNV		ECU ID
B4	61876	Manufacturing Test Date			ECU ID
B5	61877	Engine S/N(Vehicle Manufacture)			ECU ID

The interface also includes a menu bar (File, View, Operation, Tool, Help), a toolbar with icons for print, save, and other functions, and a status bar at the bottom right showing 'LOG ON' and diagnostic code information: 'Diag Code Active DTC : 1', 'Logged DTC : 5'.

Figure 7-26 [ECU Identification] - [ECU ID Information] Screen



## 7.8 System Installation

This function is required for the initial setting after installing the engine and repair, and installation and adjustment when replacing the ECU and so on. It consists of the Configuration, Calibration, and Tuning submenus. It also provides a function to create a report file after the completion of maintenance.

### 7.8.1 Configuration 【Mechanic Function】

This submenu provides the system initial setup function (not used for some models) and the function to copy (upload, download, and copy wizard) and rewrite the configuration file when replacing the ECU or pump.

#### 1) Operation tool bar



- ①  : Prints a hardcopy of the screen.
- ②  : Saves the screen in BMP format.
- ③  : Saves data on the screen in CSV format.

#### 2) Main view

This view displays a list of items you can set.

- ④ **Description** : Displays the setting item.
- ⑤ **Value** filed : Displays the current setting value. Clicking this field opens the Data Set window. To make any changes, you need to enter a password.
- ⑥ **Notes** : Displays reference information to enter the setting.

#### 3) Data Set sub-window

- ⑦ **Data Name** : Displays the name of the item whose setting value is to be changed.
- ⑧ **Present** : Displays the current setting value.
- ⑨ **Max** : Shows the maximum value that can be set .
- ⑩ **Current** : Shows a value to be set.
- ⑪ **Min** : Displays the minimum value that can be set.
- ⑫ **Note** : Note.
- ⑬  /  : Increases/decreases the setting value with one of the factors : 1, 10, or 100.
- ⑭ **Set** : Outputs the set data to the ECU.
- ⑮ **Cancel** : Cancels the set data and closes the sub-window.

#### 4) Function buttons

- ⑯ **Part exchange** : Lets you enter configuration data (pump's serial number and injection quantity correction value <loading a file or entering it manually>, and caution for calibration input for timer correction value) when replacing the fuel injection pump.
- ⑰ **ECU exchanges** : Lets you copy the configuration data and save it in a file when replacing the ECU.

#### 5) Configuration items that can be changed

- Not used for the basic specifications of the TNV

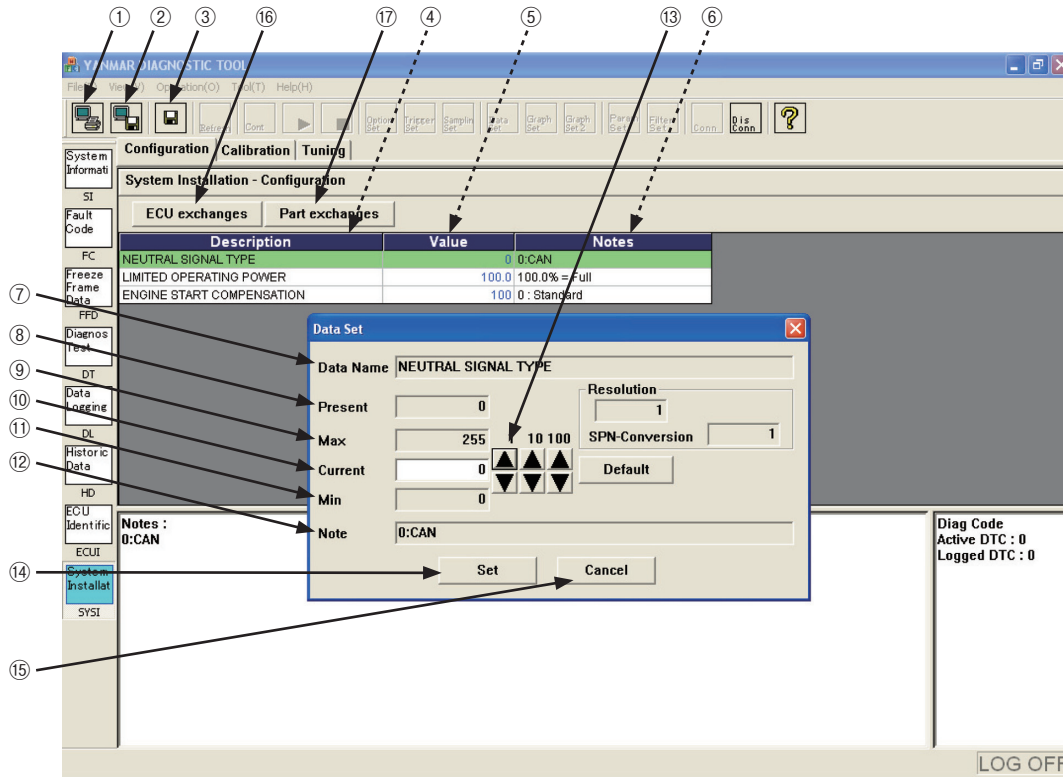

Figure 7-27 [System Installation] - [Configuration] Screen

### 7.8.1.1 ECU Exchange

○ Information that must be copied when replacing the ECU.

- 1) Correction information: ① Pump injection quantity correction value, ② Engine output correction value ( )
- 2) Configuration value
- 3) Calibration value
- 4) Tuning value
- 6) Serial number : ① Engine serial number, ② Pump serial number
- 7) Additional information : ① Calibration date (date inside PC), ② Calibration device number (license key)

#### 7.8.1.1.1 Copy from Old ECU

When the ECU program is running normally and the CAN communication functions normally, you can copy the setting values (correction values, etc) from the current (old) controller to the new controller. Follow these steps.

<Procedure>

- ① Click the **ECU exchanges** button on the [Configuration] screen.
- ② Checkmark  **Copy** .
- ③ Click the **Read** button.
- ④ Click the **Save** button.
- ⑤ Choose a folder to save the file, enter a file name, and save it.
- ⑥ Close the program, turn off the ECU, and replace the ECU.
- ⑦ Turn on the ECU, start the tool program, and display this screen.
- ⑧ Checkmark  **Copy** .
- ⑨ Click the **Load** button to load the file saved in ④ .
- ⑩ Click the **Write** button in the lower left part of the sub-window.
- ⑪ A report file is created after writing.

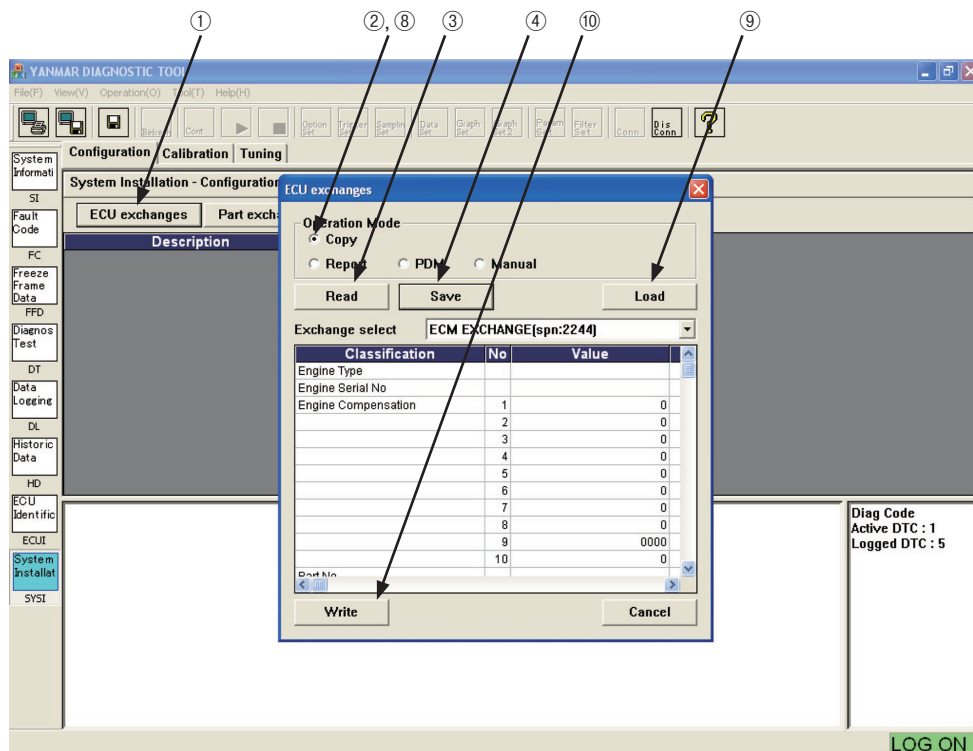

Figure 7-28 [System Installation] - [Configuration] - [ECU exchange] Screen

### 7.8.1.1.2 Writing Data Received from the PDM

If the ECU is broken and data cannot be read, you can receive data from the PDM and write the correction values to the ECU using the following procedure. First, you need to receive the pump correction data file (pump\_serial.excp) and the engine correction data file (engine\_serial.exce) for the model name and serial number of your engine in advance. Note that, in this case, the configuration, calibration, and tuning data are not written. Therefore, you need to reenter each item using the menu.

#### <Procedure>

- ① Click the **ECU exchanges** button on the [Configuration] screen.
- ② Checkmark  **PDM**.
- ③ Click the **Load** button to load the file that has been received from the PDM and saved (select the folder where the file is saved, select the file, and open it).
- ④ Click the **Write** button in the lower left part of the sub-window.
- ⑤ A report file is created after writing.

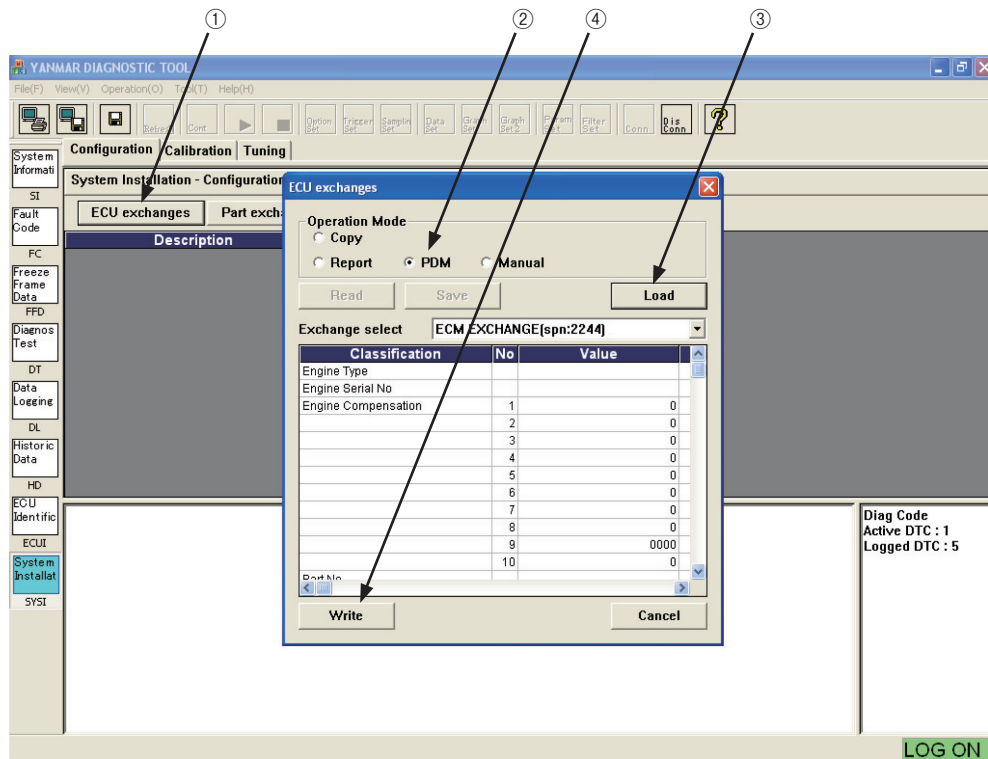

Figure 7-29 [System Installation] - [Configuration] - [ECU exchange] / PDM Screen

## 7.8.1.1.3 Manual Entry

If the ECU is broken, data cannot be read, and you cannot receive data from the PDM, you can manually write the correction values to the ECU. In this case, first, you need to obtain the pump correction data and the engine correction data (eg, paper document) for the model name and serial number of your engine in advance from the PDM. Note that, in this case, the configuration, calibration, and tuning data are not written. Therefore, you need to reenter each item using the menu.

## &lt;Procedure&gt;

- ① Click the **ECU exchanges** button on the [Configuration] screen.
- ② Checkmark  **Manual** .
- ③ Click the **Value** you want to write. The sub-window to enter data opens.
- ④ Set the data using the arrow keys (or type it directly), and click the **Set** button.
- ⑤ Repeat Steps ③ and ④ .
- ⑥ When you finish the entry in the above step, click the **Write** button in the lower left part of the sub-window.
- ⑦ A report file is created after writing.

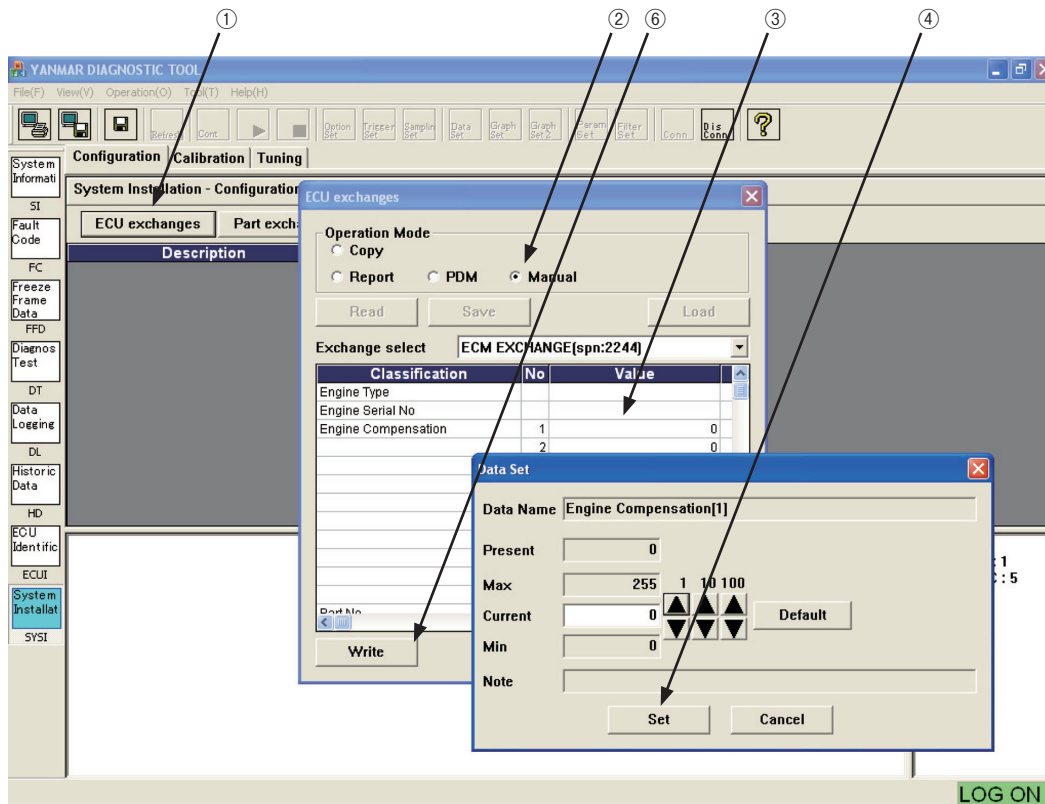

Figure 7-30 [System Installation] - [Configuration] - [ECU exchange] / Manual Entry Screen

### 7.8.1.1.4 Creating a Report

When you write the injection quantity correction value to the ECU, a menu to create a report opens automatically. When you perform maintenance, you can save the current ECU settings to a report file manually.

#### <Procedure>

- ① Click the **ECU exchanges** button on the [Configuration] screen.
- ② Checkmark  **Report**.
- ③ Click the **Read** button.
- ④ When the confirmation dialog box opens, click the **Y** button.
- ⑤ Specify a report file name and folder name to save.

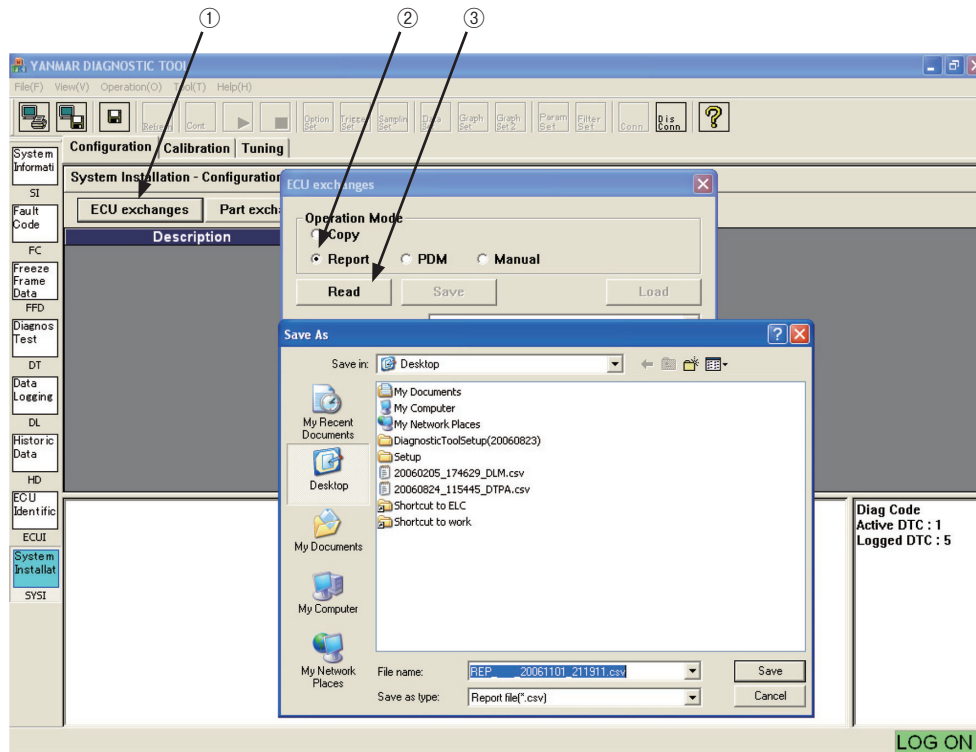

Figure 7-31 [System Installation] - [Configuration] - [ECU exchange] / Report

### 7.8.1.2 Replacing the Pump

○ Information that must be written when replacing the pump.

- 1) Correction information : ① Pump injection quantity correction value
- 2) Serial number : ① Pump serial number
- 3) Additional information : ① Calibration date (data inside PC), ② Calibration device number (license key)

#### 7.8.1.2.1 Writing Data Received from the PDM

When you replace the pump, you need to receive data from the PDM and write the correction values to the ECU using the following procedure. First, you need to receive the pump correction data file (pump\_serial.excpt) for the model name and serial number of your pump in advance.

#### <Procedure>

- ① Click the **Part exchange** button on the [Configuration] screen.
- ② On the sub-window that opens, checkmark **PDM**.
- ③ Click the **Load** button to load the file that has been received from the PDM and saved (select the folder where the file is saved, select the file, and open it).
- ④ Click the **Write** button in the lower left part of the sub-window.
- ⑤ A report file is created after writing.

#### 7.8.1.2.2 Manual Entry

As with replacing the ECU, you can enter data manually.

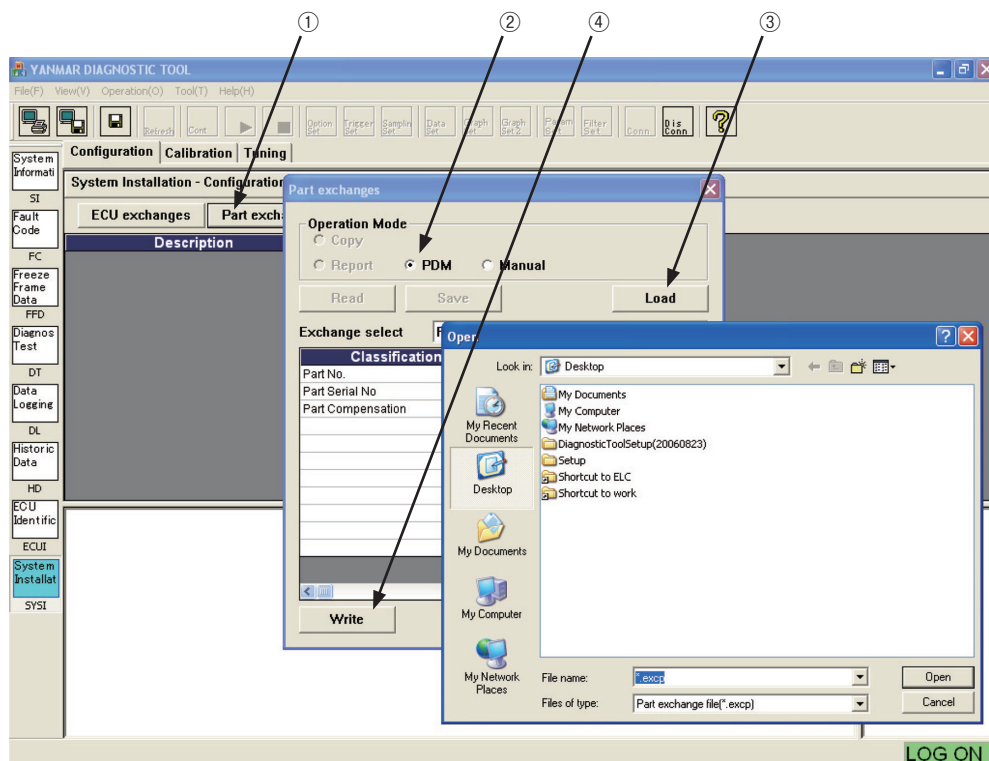





Figure 7-32 [System Installation] - [Configuration] - [Part exchange] / PDM Screen

## 7.8.2 Calibration [Mechanic Function]

This screen provides the function to calibration (correct) the sensor. You can perform the digital calibration of the reference position for the accelerator position sensor, and check the origin calibration value at the time of injection.

### 1) Operation tool bar

- ①  : Prints a hardcopy of the screen.
- ②  : Saves the screen in BMP format.
- ③  : Saves buffered data in a CSV file.

### 2) Main view

- ④ **Description** : Calibration item.
- ⑤ **Offset** : Displays the current offset value. Clicking this field opens the Data Set window that lets you change the value.
- ⑥ **Notes** : Notes.

• The Data Set window is the same as that for the Configuration screen. See the previous section.

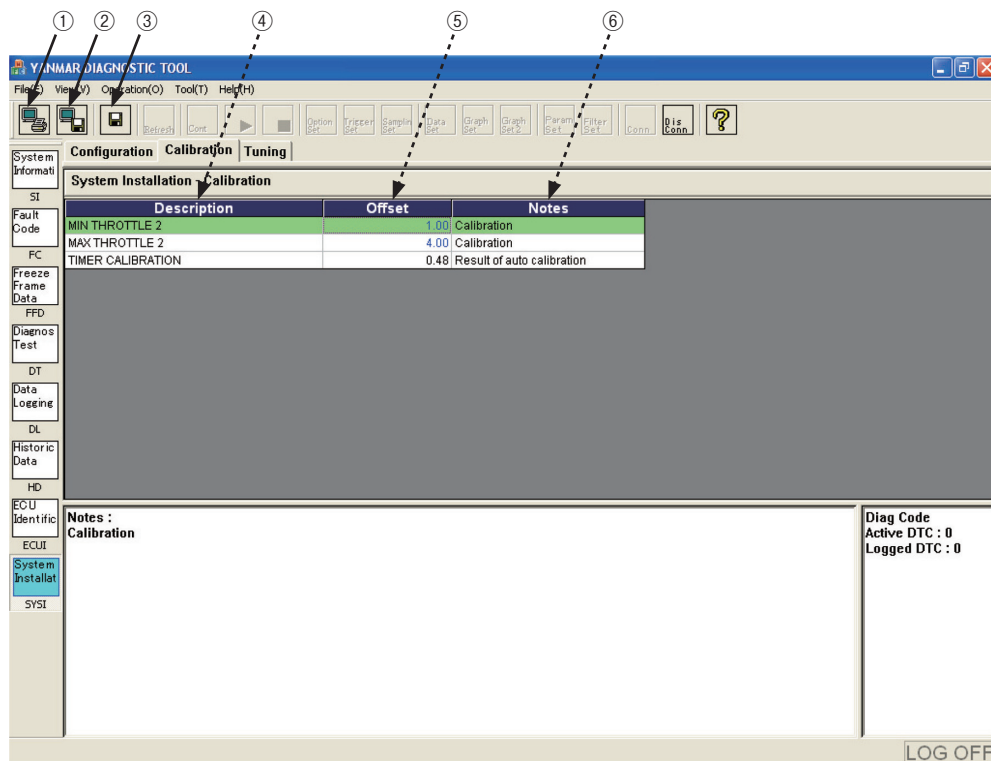





Figure 7-33 [System Installation] - [Calibration] Screen

### 7.8.3 Tuning [Mechanic Function]

This screen provides the function to set engine's low idle rotation, select the torque pattern, and fine-tune the speed governing performance. You can make correction within the range according to the emission regulations.

#### 1) Operation tool bar

- ①  : Prints a hardcopy of the screen.
- ②  : Saves the screen in BMP format.
- ③  : Saves data on the screen in CSV format.

#### 2) Main view

- ④ **Description** : Setting item.
- ⑤ **Value** : Displays the current parameter value. Clicking this field opens the Data Set window that lets you change the parameter.
- ⑥ **Unit** : Unit.
- ⑦ **Notes** : Notes.

• The Data Set window is the same as that for the Configuration screen. See the previous section.

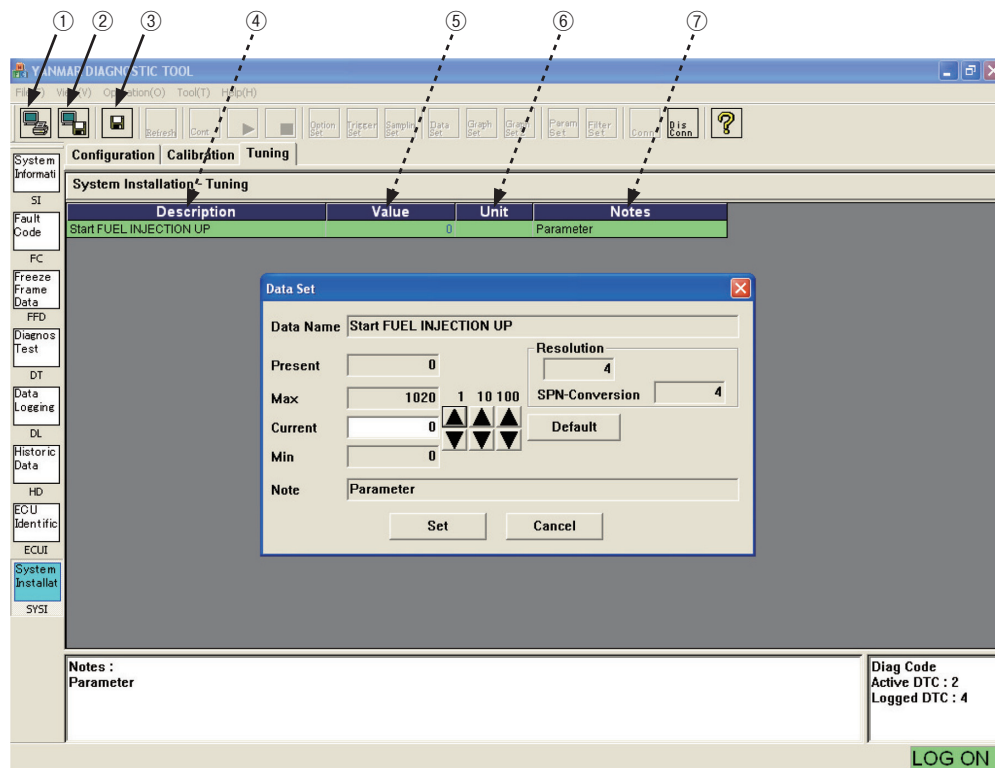

Figure 7-34 [System Installation] - [Tuning] Screen



# 8. Graph Function

The basic functions to display and operate graphs are common to the following screens.

- ① [FFD] - [Trend Graph], ② [Diagnostic Test] - [Active Control Graph],
- ③ [Data Logging] - [Trend Graph]

## 8.1 Setting the Graphs

The following functions are available for graph settings.

- 1) You can set 2 graph screens (top and bottom) by pressing the  and  buttons on the Operation tool bar.
- 2) On each screen, you can select from analog mode and digital mode, and display 4 line plots. Note that, you cannot mix analog and digital on a single screen.
- 3) In analog mode, you can set the minimum value and maximum value for the full scale.
- 4) You can save graph settings as a definition file. You can load a graph pattern depending on the type of trouble.

### 8.1.1 Basic Operations in Analog Mode

The basic operations in analog mode are as follows :

- ① Selecting analog mode : Click  Analog of Display Mode to checkmark it.
- ② Selecting data 1 : Click the Data Select No.1 combo box, and select the data you want to graph using the scrollbar.
- ③ Setting the minimum value : Set the minimum value of the graph with the spin button.
- ④ Setting the maximum value : Set the maximum value of the graph with the spin button. The scaling is performed based on the maximum and minimum values. Note that you need to decide them considering that the Y axis is divided into 4 sections by the ruled lines.
- ⑤ Setting data 2 to data 4 : As necessary, repeat Steps ② to ④ to set data 2 to data 4.
- ⑥ Reflecting the settings : Click the  button. The settings are reflected and the graphs are displayed.

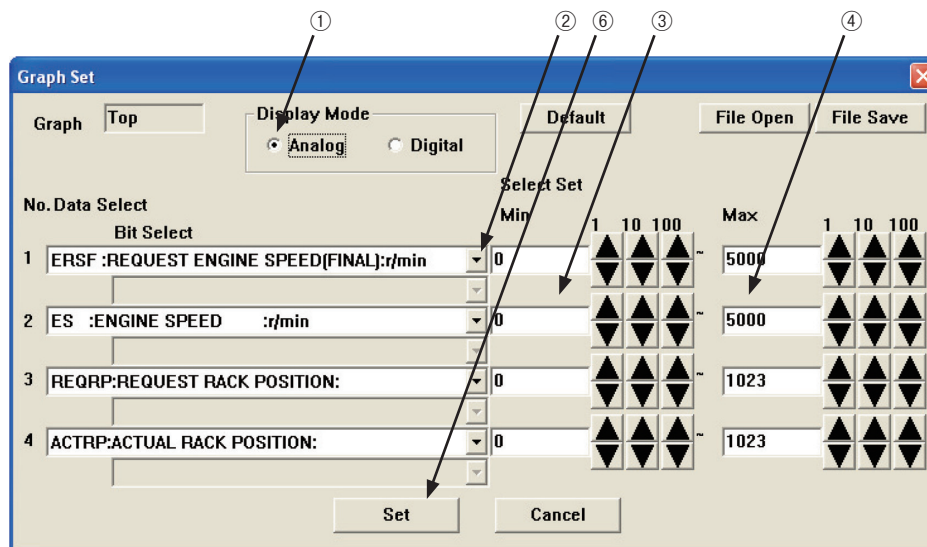



Figure 8-1 [Graph Set] - [Analog Mode] Screen

## 8.1.2 Saving and Loading Setting Values

You can save graph settings, and load and use them later.

### 8.1.2.1 Saving a File

- ① Opening the Graph Set screen : Click the  or  button on the Operation tool bar. The sub-window opens.
- ② Opening the file save screen : Click the **File Save** button in the upper right of the Graph Set sub-window. The save screen opens.
- ③ Saving a file : Save a file with a name you can easily search for later. The file extension is gset. The default file folder is Set.

### 8.1.2.2 Opening a File

- ④ Open screen : After the step of ①, click the **Open** button in the upper right of the sub-window. The Open screen opens.
- ⑤ Selecting a file : Select a file displayed in the sub-window. Open the file to load and apply the graph setting values that have been saved.

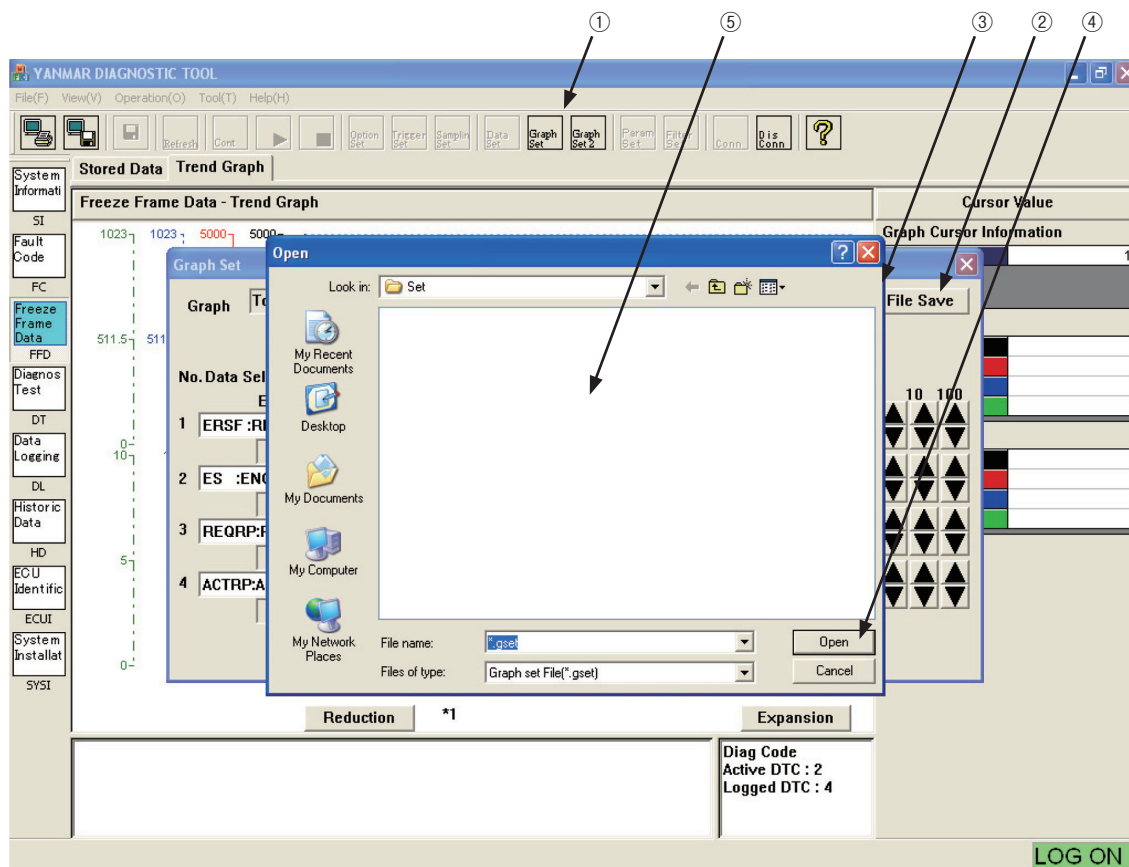

Figure 8-2 [Graph Set] - [Open] Screen

### 8.1.3 Digital Mode

This mode is used to display the ON/OFF information of digital inputs/outputs and control flags. You need to know the parameters and bit numbers corresponding to the necessary information in advance. Data items you can select are DIS1, DIS2, DOS1, and DOS2. For information on detailed data, see ECU\_ID (Chapter 7.7.2).

- ① Selecting digital mode : Click  Digital of Display Mode to checkmark it.
- ② Selecting data 1 : Click the Data Select No. 1 combo box, and select the data you want to graph using the scrollbar.
- ③ Selecting the bit to be displayed : Click the combo box of Data Select No. 1 in the lower middle part, and select the bit of the data you want to graph using the scrollbar.
- ④ Setting data 2 to data 4 : As necessary, repeat Steps ② to ④ to set data 2 to data 4.
- ⑤ Reflecting the settings : Click the  button. The settings are reflected and the graphs are displayed.

You can save and open a file in the same way as in analog mode.

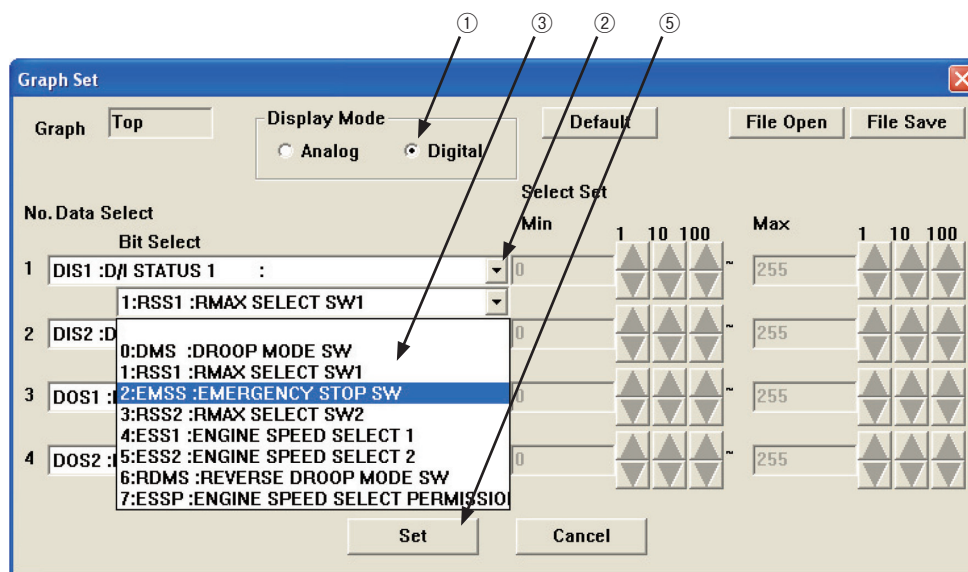

Figure 8-3 [Graph Set] - [Digital Mode] Screen

## 8.2 Graph Operations

- ① Reducing the time axis : You can check a rough data trend by clicking the **Reduction** button to reduce the time axis. The display magnification is shown to the right of the button. \*1 is the minimum.
- ② Expanding the time axis : When you want to focus on a part, click the **Expansion** button to zoom in to view its details. The maximum magnification is 10.
- ③ Scrolling in the window : You can move the display range of the expanded graph with the scroll bar.
- ④ Moving the cursor to check the values : Click the point of interest. The cursor moves to the point and the data values at the point are displayed in the Cursor Value field.
- ⑤ Expanding/reducing the Y axis : Drag the lower border of the graph window (the mouse pointer changes from the arrow to the double-headed arrow indicating the border) to expand/reduce the Y axis.

Data Select No.	Cursor Value field		Line graph		
	Position	Background color	Line color	Line type	Y-axis scale
1	Top	Black	Black	Solid line	Inside
2	↑	Red	Red	Dotted line	↑
3	↓	Blue	Blue	Chain dashed line	↓
4	Bottom	Green	Green	Chain double-dashed line	Outside

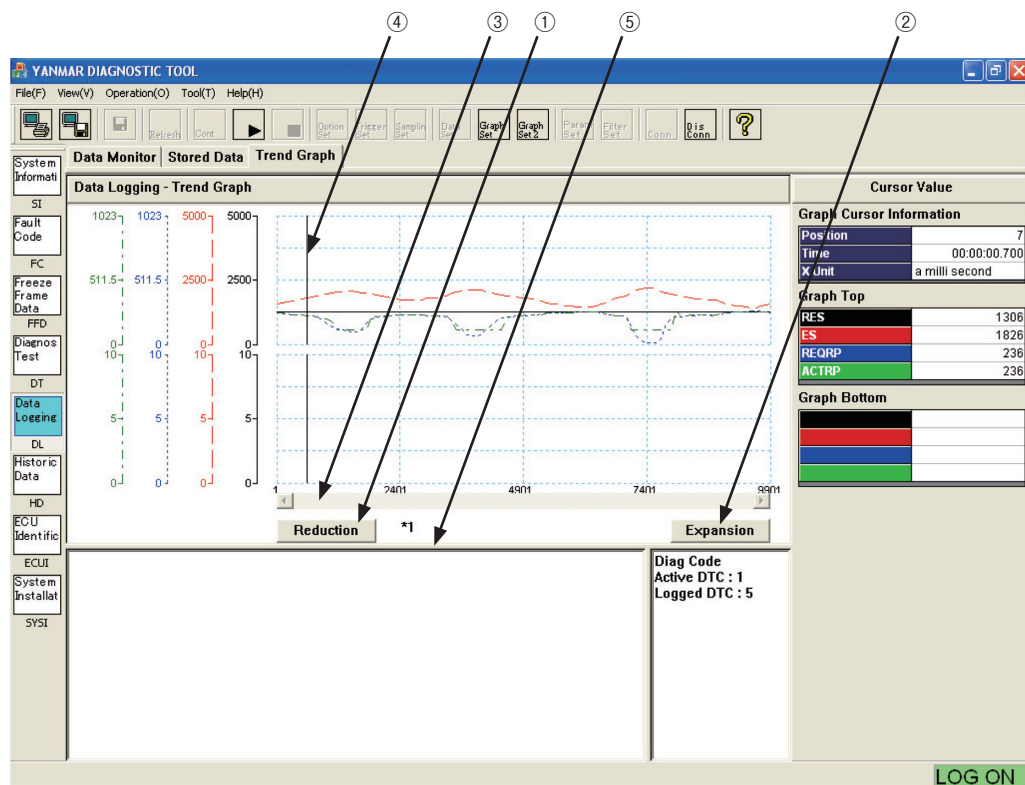

Figure 8-4 Overview of Graph Operations

## 9. Print Function

---

You can print the displayed screen by clicking the  button on the Operation tool bar.

## 10. Saving and Loading Data

---

You can save data in tabular format into a comma separated value format file by clicking the  button on the Operation tool bar. You can import saved data to Microsoft Excel. Therefore, you can analyze and graph data more precisely with the application.

# 11. Tool Functions

## 11.1 System Setting

You can change parameters for the CAN communication. To change the parameters, you need sufficient knowledge about CAN. If you change them incorrectly, the communication may become unavailable. So, do not change them without good reason.

Choose the Standard tool bar - [Tool (T)] - [System Setting] . The sub-window opens.

- ① **Set Select (Set Name)** : You can register/load 4 names.
- ② **Port** : Fixed to USB.
- ③ **Priority** : The standard value is 6.
- ④ **Physical address** : The standard value is DA00h. If your system has several ECU's, you may need to change 00h.
- ⑤ **Function address** : Fixed to DB33h.
- ⑥ **SA** : The address of the service tool. Fixed to F0h.
- ⑦ **Data Rate** : Baud rate for communication. The standard value is 250 kbps for marine applications and 500 kbps for land applications.
- ⑧ **CAN** : Parameter for the CAN signal. No need to change.
- ⑨ **ISO15765** : Parameter for flow control. No need to change.
- ⑩ **Message timing** : Timing parameter for CAN messages. No need to change.

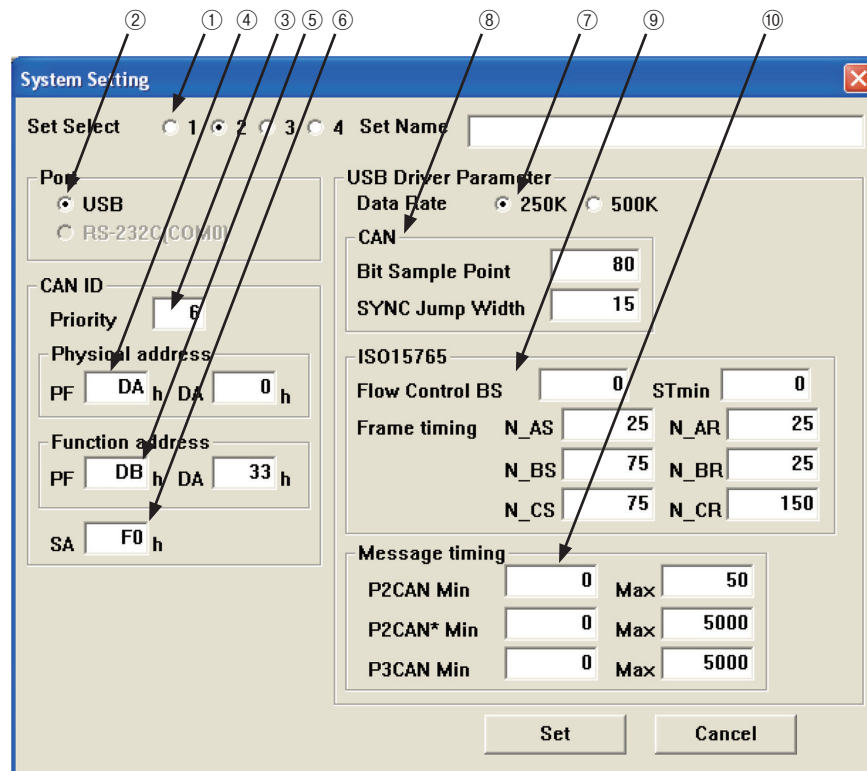

Figure 11-1 Standard tool bar - [Tool (T)] - [System Setting] Screen

## 11.2 User Management

This screen lets you register new users and change/delete IDs and passwords.

Choose the Standard tool bar - [Tool (T)] - [User Set (U)] . The sub-window opens.

### 1) Additional registration

There is a restriction to user IDs that can be added depending on the authority of the user ID used to log in. User IDs with a higher authority level than the login user ID cannot be added.

- ① Click the **Add** button. The sub-window for entry opens.
- ② Enter a user ID and password, and set its authority level.
- ③ Click the **OK** button. The registration is completed.

### 2) Edit

There is a restriction to user IDs that can be edited depending on the authority of the user ID used to log in. There is no restriction on editing lower-level user IDs. For same-level user IDs, the user cannot change them without entering the current password. To change the password of the current login user, the menu of [Tool (T)] - [Password Change (P)] must be used. (See 11.3.)

- ① Place the cursor to the user you want to edit, and click the **Edit** button.
- ② Enter the password again, and click the **OK** button. The registration is completed.

### 3) Deletion

There is a restriction to user IDs that can be deleted depending on the authority of the user ID used to log in. There is no restriction on deleting lower-level user IDs. For same-level user IDs, the user cannot delete them without entering the present password. The current login user cannot be deleted.

- ① Place the cursor to the user you want to delete, and click the **Delete** button.
- ② When the confirmation dialog box opens, click the **OK** button. The user is deleted.

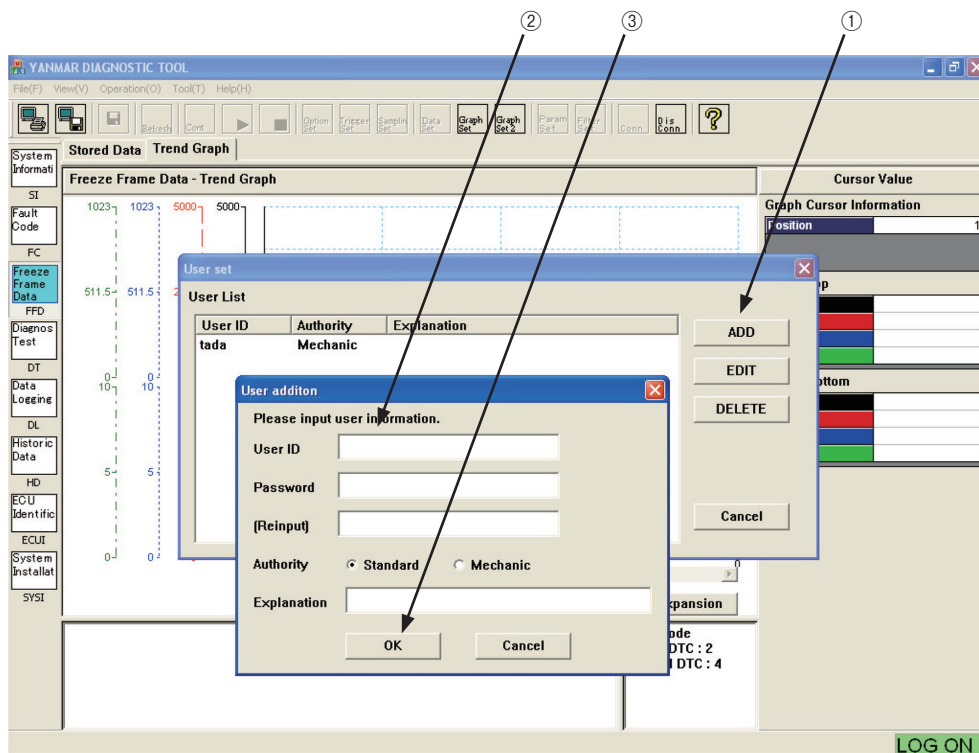

Figure 11-2 Standard tool bar - [Tool (T)] - [User Set (U)] Screen

## 11.3 Changing a Password

This screen is used to change the password for the current login user ID. Change the password periodically. Choose the Standard tool bar - [Tool (T)] - [Password Change] . The sub-window opens.

- ① **An old password** : Enter the current password.
- ② **A new password** : Enter a new password.
- ③ **[Reinput]** : Enter the new password for confirmation.

The screenshot shows a 'Password change' dialog box with a blue title bar and a close button. The main area is light beige and contains the text 'Please input a new password.' followed by four input fields. The first field is labeled 'User ID' and contains the text 'tada'. The second field is labeled 'An old password', the third is 'A new password', and the fourth is '[Reinput]'. At the bottom of the dialog are two buttons: 'OK' and 'Cancel'. Three numbered callouts (1, 2, 3) point to the 'An old password', 'A new password', and '[Reinput]' fields respectively.

Figure 11-3 Standard tool bar - [Tool (T)] - [Password Change] Screen

## 12. Glossary

---

BS	Block Size	Variable related to flow control used in ISO15765.
CAN	Controller Area Network	Communication standard used for in-vehicle LAN.
CSV	Comma Separated Value	File format used for PCs.
DA	Destination Address	ID information in CAN communication data.
D-SUB		Connector standard.
DTC	Diagnostic Trouble Code	Coded information for troubles.
ECU	Engine ( or Electronic) Control Unit	Engine Control Unit is also called ECM.
FFD	Freeze Flame Data	Related data before and after a trouble.
FMI	Failure Mode Identifier	Detailed failure information added to DTC.
LID	Local Identifier	ID information specific to a certain controller.
OC	Occurrence Counter	Number of DTC occurrences.
PC	Personal Computer	
PF	Protocol Data Unit Format	ID information in CAN communication data.
PDM	Product Data Management	
SA	Source Address	ID information in CAN communication data.
SAE	Society of Automotive Engineers	
Sno.	Serial Number	Manufacturing serial number of engine, pump, and ECU.
SPN	Suspect Parameter Number	ID commonly used for SAE J1939.
USB	Universal Serial Bus	Serial communication port used for PCs.

## 13. Appendix

---

Appendix : FMI (Failure Mode Identifier) List

FMI	Description
0	DATA VALID BUT ABOVE NORMAL OPERATIONAL RANGE
1	DATA VALID BUT BELOW NORMAL OPERATIONAL RANGE
2	DATA ERRATIC,INTERMITTENT OR INCORRECT
3	VOLTAGE ABOVE NORMAL ,OR SHORTED TO HIGH SOURCE
4	VOLTAGE BELOW NORMAL ,OR SHORTED TO LOW SOURCE
5	CURRENT BELOW NORMAL OR OPEN CIRCUIT
6	CURRENT ABOVE NORMAL OR GROUNDED CIRCUIT
7	MECHANICAL SYSTEM NOT RESPONDING OR OUT OF ADJUSTMENT
8	ABNORMAL FREQUENCY OR PULSE WIDTH OR PERIOD
9	ABNORMAL UPDATE RATE
10	ABNORMAL RATE OF CHANGE
11	FAILURE CODE NOT IDENTIFIABLE
12	BAD INTELLIGENT DEVICE OR COMPONENT
13	OUT OF CALIBRATION
14	SPECIAL INSTRUCTIONS
15	NORMAL

## 14. References

---

For information on details of "Probable cause" and "Action" displayed when a trouble occurs, see the separate manual "Troubleshooting Manual."