



NO POSTAGE
NECESSARY
IF MAILED
IN THE
UNITED STATES

BUSINESS REPLY MAIL
FIRST CLASS PERMIT NO. 15, COLUMBUS INDIANA

—POSTAGE WILL BE PAID BY ADDRESSEE—

Cummins Inc.
Product Registration Dept.
P O Box 3005 M/C 60610
Columbus, IN 47202-3005

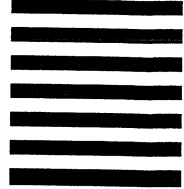

In order to serve you better it is very important that you fill out and return this card **within 30 days** of purchase.

Customer Name _____

Address _____

City / State _____

Zip Code _____

Home Phone Number (____) _____

Truck Phone / Cell Phone (____) _____

E-mail Address _____

Engine Serial Number _____

Date Purchased ____/____/____ VIN # _____

OR visit our website at www.cummins.com and select "Product Registration" to enter your registration online.

THANK YOU!!



Operation and Maintenance Manual QSB4.5 and QSB6.7 Engine

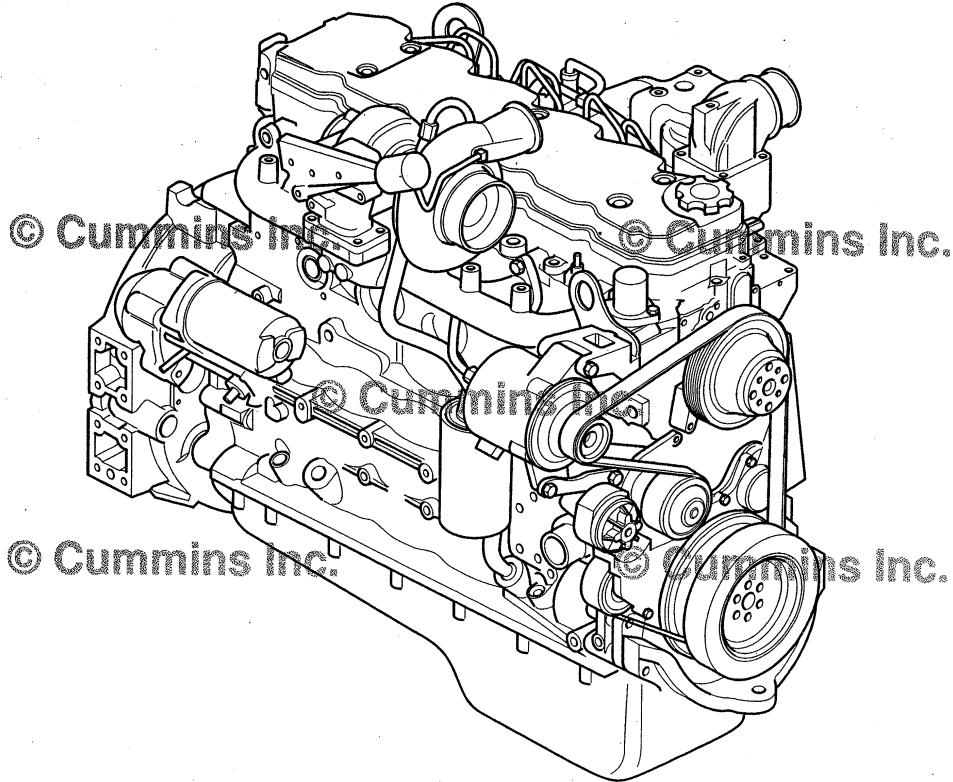

00d00182

Foreword

This manual contains information for the correct operation and maintenance of your Cummins engine. It also includes important safety information, engine and systems specifications, troubleshooting guidelines, and listings of Cummins Authorized Repair Locations and component manufacturers.

Read and follow all safety instructions. Refer to the WARNING in the General Safety Instructions in Section I - Introduction.

Keep this manual with the equipment. If the equipment is traded or sold, give the manual to the new owner.

The information, specifications, and recommended maintenance guidelines in this manual are based on information in effect at the time of printing. Cummins Inc. reserves the right to make changes at any time without obligation. If you find differences between your engine and the information in this manual, contact your local Cummins Authorized Repair Location or call 1-800-DIESELS (1-800-343-7357) toll free in the U.S. and Canada.

The latest technology and the highest quality components were used to produce this engine. When replacement parts are needed, we recommend using only genuine Cummins or ReCon® exchange parts.

NOTE: Note: Warranty information is located in Section W. Make sure you are familiar with the warranty or warranties applicable to your engine.

Table of Contents

Section

Introduction	i
Engine Identification	E
Industrial Features	FB
Operating Instructions	1
Maintenance Guidelines	2
Maintenance Procedures at Daily Interval	3
Maintenance Procedures at 250 hours or 3 months	4
Maintenance Procedures at 500 hours or 6 months	5
Maintenance Procedures at 1000 Hours or 1 Year	6
Maintenance Procedures at 2000 Hours or 2 Years	7
Maintenance Procedures at 5000 hours or 4 years	8
Adjustment, Repair, and Replacement	A
System Diagrams	D
Service Literature	L
Component Manufacturers	M
Service Assistance	S
Troubleshooting Symptoms	TS
Maintenance Specifications	V
Warranty	W



Important Reference Numbers

Fill in the part name and number in the blank spaces provided below. This will give you a reference whenever service or maintenance is required.

Name	Number	Number
Engine Model		
Engine Serial Number (ESN)		
Control Parts List (CPL)		
Fuel Pump Part Number		
Electronic Control Module (ECM)		
Electronic Control Module Serial Numbers (ECM)		
Filter Part Numbers:		
• Air Cleaner Element		
• Lubricating Oil		
• Fuel		
• Fuel-Water Separator		
• Coolant		
• Crankcase Ventilation		
• Cummins Particulate Filter		
Governor Control Module (GCM) (if applicable)		
Belt Part Numbers:		
•		
•		
•		
Clutch or Marine Gear (if applicable):		
• Model		
• Serial Number		
• Part Number		
• Oil Type		
• Sea Water Pump		
- Model		
- Part Number		

Section i - Introduction

Section Contents

	Page
About the Manual	i-2
General Information.....	i-2
Acronyms and Abbreviations	i-13
General Information.....	i-13
General Cleaning Instructions	i-9
Abrasive Pads and Abrasive Paper.....	i-9
Definition of Clean.....	i-9
Gasket Surfaces.....	i-10
Plastic Bead Cleaning.....	i-11
Solvent and Acid Cleaning.....	i-10
Steam Cleaning.....	i-11
General Repair Instructions	i-8
General Information.....	i-8
Welding on a Vehicle with an Electronic Controlled Fuel System.....	i-8
General Safety Instructions	i-6
Important Safety Notice.....	i-6
How to Use the Manual	i-3
General Information.....	i-3
Illustrations	i-5
General Information.....	i-5
Symbols	i-4
General Information.....	i-4
To the Owner and Operator	i-1
General Information.....	i-1

This Page Left Intentionally Blank

To the Owner and Operator

General Information

Preventive maintenance is the easiest and least expensive type of maintenance. Follow the maintenance schedule recommendations outlined in Maintenance Guidelines (Section 2).

Keep records of regularly scheduled maintenance.

Use the correct fuel, lubricating oil, and coolant in your engine as specified in Maintenance Specifications (Section V). Blending engine oil with fuel is prohibited for engines with an aftertreatment system.

Cummins Inc. uses the latest technology and the highest quality components to produce its engines. Cummins Inc. recommends using genuine Cummins new parts and ReCon® exchange parts.

Personnel at Cummins Authorized Repair Locations have been trained to provide expert service and parts support. If you have a problem that can **not** be resolved by a Cummins Authorized Repair Location, follow the steps outlined in the Service Assistance (Section S).

Product coverage, warranty limitations and owner responsibilities are available in Warranty (Section W).

▲CAUTION▲

Disconnect both the positive (+) and negative (-) battery cables from the battery before welding on the vehicle. Attach the welder ground cable no more than 0.61 meters [2 feet] from the part being welded. Do not connect the ground cable of the welder to the ECM cooling plate or ECM. Welding on the engine or engine mounted components is not recommended.

About the Manual

General Information

This manual contains information needed to correctly operate and maintain your engine as recommended by Cummins Inc. For additional service literature and ordering locations, refer to Service Literature (Section L).

This manual does not cover vehicle, vessel, or equipment maintenance procedures. Consult the original vehicle, vessel, or equipment manufacturer for specific maintenance recommendations.

Both metric and U.S. customary values are listed in this manual. The metric value is listed first, followed by the U.S. customary in brackets.

Numerous illustrations and symbols are used to aid in understanding the meaning of the text. Refer to Symbols in this section for a complete listing of symbols and their definitions.

Each section of the manual is preceded by a Section Contents to aid in locating information.

How to Use the Manual

General Information

This manual is organized according to intervals at which maintenance on your engine is to be performed. A maintenance schedule, that states the required intervals and maintenance checks, is located in Maintenance Guidelines (Section 2). Locate the interval at which you are performing maintenance; then follow the steps given in that section for all the procedures to be performed.

Keep a record of all the checks and inspections made. A maintenance record form is located in Maintenance Guidelines (Section 2).













Engine troubleshooting procedures for your engine are located in Troubleshooting Symptoms (Section TS).

Specifications for your engine are located in Maintenance Specifications (Section V).

Symbols

General Information

The following symbols have been used in this manual to help communicate the intent of the instructions. When one of the symbols appears, it conveys the meaning defined below:

	WARNING - Serious personal injury or extensive property damage can result if the warning instructions are not followed.		PERFORM a mechanical or time MEASUREMENT .
	CAUTION - Minor personal injury can result or a part, an assembly, or the engine can be damaged if the caution instructions are not followed.		LUBRICATE the part or assembly.
	Indicates a REMOVAL or DISASSEMBLY step.		Indicates that a WRENCH or TOOL SIZE will be given.
	Indicates an INSTALLATION or ASSEMBLY step.		TIGHTEN to a specific torque.
	INSPECTION is required.		PERFORM an electrical MEASUREMENT .
	CLEAN the part or assembly.		Refer to another location in this manual or another publication for additional information.
			The component weighs 23 kg [50 lb] or more. To avoid personal injury, use a hoist or get assistance to lift the component.

Illustrations

General Information

Some of the illustrations throughout this manual are generic and will **not** look exactly like the engine or parts used in your application. The illustrations can contain symbols to indicate an action required and an acceptable or **not** acceptable condition.

The illustrations are intended to show repair or replacement procedures. The procedure will be the same for all applications, although the illustration can differ.

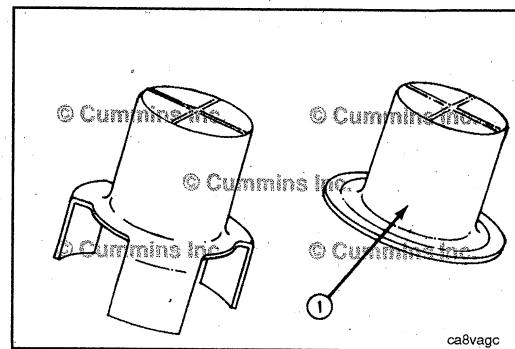
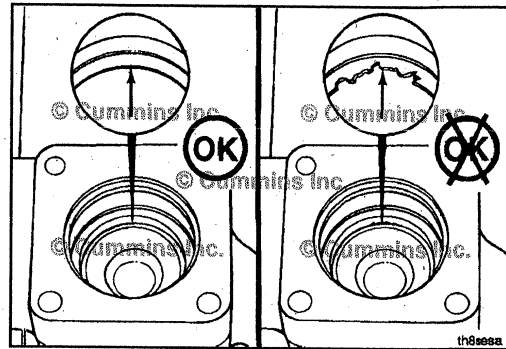

General Safety Instructions

Important Safety Notice



Improper practices, carelessness, or ignoring the warnings can cause burns, cuts, mutilation, asphyxiation or other personal injury or death.

Read and understand all of the safety precautions and warnings before performing any repair. This list contains the general safety precautions that **must** be followed to provide personal safety. Special safety precautions are included in the procedures when they apply.

- Work in an area surrounding the product that is dry, well lit, ventilated, free from clutter, loose tools, parts, ignition sources and hazardous substances. Be aware of hazardous conditions that can exist.
- **Always** wear protective glasses and protective shoes when working.
- Rotating parts can cause cuts, mutilation or strangulation.
- Do **not** wear loose-fitting or torn clothing. Remove all jewelry when working.
- Disconnect the battery (negative [-] cable first) and discharge any capacitors before beginning any repair work. Disconnect the air starting motor if equipped to prevent accidental engine starting. Put a "Do **Not** Operate" tag in the operator's compartment or on the controls.
- Use **ONLY** the proper engine barring techniques for manually rotating the engine. Do **not** attempt to rotate the crankshaft by pulling or prying on the fan. This practice can cause serious personal injury, property damage, or damage to the fan blade(s) causing premature fan failure.
- If an engine has been operating and the coolant is hot, allow the engine to cool before slowly loosening the filler cap to relieve the pressure from the cooling system.
- **Always** use blocks or proper stands to support the product before performing any service work. Do **not** work on anything that is supported **ONLY** by lifting jacks or a hoist.
- Relieve all pressure in the air, oil, fuel, and cooling systems before any lines, fittings, or related items are removed or disconnected. Be alert for possible pressure when disconnecting any device from a system that utilizes pressure. Do **not** check for pressure leaks with your hand. High pressure oil or fuel can cause personal injury.
- To reduce the possibility of suffocation and frostbite, wear protective clothing and **ONLY** disconnect liquid refrigerant (Freon) lines in a well ventilated area. To protect the environment, liquid refrigerant systems **must** be properly emptied and filled using equipment that prevents the release of refrigerant gas (fluorocarbons) into the atmosphere. Federal law requires capturing and recycling refrigerant.
- To reduce the possibility of personal injury, use a hoist or get assistance when lifting components that weigh 23 kg [50 lb] or more. Make sure all lifting devices such as chains, hooks, or slings are in good condition and are of the correct capacity. Make sure hooks are positioned correctly. **Always** use a spreader bar when necessary. The lifting hooks **must not** be side-loaded.
- Corrosion inhibitor, a component of SCA and lubricating oil, contains alkali. Do **not** get the substance in eyes. Avoid prolonged or repeated contact with skin. Do **not** swallow internally. In case of contact, immediately wash skin with soap and water. In case of contact, immediately flood eyes with large amounts of water for a minimum of 15 minutes. **IMMEDIATELY CALL A PHYSICIAN. KEEP OUT OF REACH OF CHILDREN.**
- Naptha and Methyl Ethyl Ketone (MEK) are flammable materials and **must** be used with caution. Follow the manufacturer's instructions to provide complete safety when using these materials. **KEEP OUT OF REACH OF CHILDREN.**
- To reduce the possibility of burns, be alert for hot parts on products that have just been turned off, exhaust gas flow, and hot fluids in lines, tubes, and compartments.
- **Always** use tools that are in good condition. Make sure you understand how to use the tools before performing any service work. Use **ONLY** genuine Cummins or Cummins ReCon® replacement parts.
- **Always** use the same fastener part number (or equivalent) when replacing fasteners. Do **not** use a fastener of lesser quality if replacements are necessary.
- Do **not** perform any repair when fatigued or after consuming alcohol or drugs that can impair your functioning.
- Some state and federal agencies in the United States of America have determined that used engine oil can be carcinogenic and can cause reproductive toxicity. Avoid inhalation of vapors, ingestion, and prolonged contact with used engine oil.
- Liquified petroleum gas is heavier than air and can accumulate near the floor, in sumps, and low-lying areas.
- Natural gas is lighter than air and can accumulate under hood and awnings.
- To reduce the possibility of suffocation and frostbite, wear protective clothing and **ONLY** disconnect natural gas and liquified petroleum gas lines in a well ventilated area.
- Coolant is toxic. If **not** reused, dispose of in accordance with local environmental regulations.
- The catalyst reagent contains urea. Do not get the substance in your eyes. In Case of contact, immediately flood eyes with large amounts of water for a minimum of 15 minutes. Avoid prolonged contact with skin. In case of contact, immediately wash skin with soap and water. Do not swallow internally. In the event the catalyst reagent is ingested, contact a physician immediately.

- The catalyst substrate contains Vanadium Pentoxide. Vanadium Pentoxide has been determined by the State of California to cause cancer. Always wear protective gloves and eye protection when handling the catalyst assembly. Do not get the catalyst material in your eyes. In Case of contact, immediately flood eyes with large amounts of water for a minimum of 15 minutes. Avoid prolonged contact with skin. In case of contact, immediately wash skin with soap and water.
- The Catalyst substrate contains Vanadium Pentoxide. Vanadium Pentoxide has been determined by the State of California to cause cancer. In the event the catalyst is being replaced, dispose of in accordance with local regulations.
- California Proposition 65 Warning - Diesel engine exhaust and some of its constituents are known to the State of California to cause cancer, birth defects, and other reproductive harm.

General Repair Instructions

General Information

This engine incorporates the latest technology at the time it was manufactured; yet, it is designed to be repaired using normal repair practices performed to quality standards.

- **Cummins Inc. does not recommend or authorize any modifications or repairs to engines or components except for those detailed in Cummins Service Information. In particular, unauthorized repair to safety-related components can cause personal injury or death. Below is a partial listing of components classified as safety-related:**

- | | |
|---------------------------------|---|
| 1. Air Compressor | 12. Flywheel Mounting Capscrews |
| 2. Air Controls | 13. Fuel Shutoff Assemblies |
| 3. Air Shutoff Assemblies | 14. Fuel Supply Tubes |
| 4. Balance Weights | 15. Lifting Brackets |
| 5. Cooling Fan | 16. Throttle Controls |
| 6. Fan Hub Assembly | 17. Turbocharger Compressor Casing |
| 7. Fan Mounting Bracket(s) | 18. Turbocharger Oil Drain Line(s) |
| 8. Fan Mounting Capscrews | 19. Turbocharger Oil Supply Line(s) |
| 9. Fan Hub Spindle | 20. Turbocharger Turbine Casing |
| 10. Flywheel | 21. Vibration Damper Mounting Capscrews |
| 11. Flywheel Crankshaft Adapter | |

- **Follow all safety instructions noted in the procedures**

- Follow the manufacturer's recommendations for cleaning solvents and other substances used during the repair of the engine. Some solvents and used engine oil have been identified by government agencies as toxic or carcinogenic. Avoid excessive breathing, ingestion and contact with such substances. **Always** use good safety practices with tools and equipment.

- **Provide a clean environment and follow the cleaning instructions specified in the procedures**

- The engine and its components **must** be kept clean during any repair. Contamination of the engine or components will cause premature wear.

- **Perform the inspections specified in the procedures**

- **Replace all components or assemblies which are damaged or worn beyond the specifications**

- **Use genuine Cummins new or ReCon® service parts and assemblies**

- The assembly instructions have been written to use again as many components and assemblies as possible. When it is necessary to replace a component or assembly, the procedure is based on the use of new Cummins or Cummins ReCon® components. All of the repair services described in this manual are available from all Cummins Distributors and most Dealer locations.

- **Follow the specified disassembly and assembly procedures to reduce the possibility of damage to the components**

Complete rebuild instructions are available in the shop manual which can be ordered or purchased from a Cummins Authorized Repair Location. Refer to Section L — Service Literature for ordering instructions.

Welding on a Vehicle with an Electronic Controlled Fuel System

△CAUTION△

Disconnect both the positive (+) and negative (-) battery cables from the battery before welding on the vehicle. Attach the welder ground cable no more than 0.61 meters [2 feet] from the part being welded. Do not connect the ground cable of the welder to the ECM cooling plate or ECM. Welding on the engine or engine mounted components is not recommended or damage to the engine or components can result.

General Cleaning Instructions

Definition of Clean

Parts **must** be free of debris that can contaminate any engine system. This does **not** necessarily mean they have to appear as new.

Sanding gasket surfaces until the factory machining marks are disturbed adds no value and is often harmful to forming a seal. It is important to maintain surface finish and flatness tolerances to form a quality sealing surface. Gaskets are designed to fill small voids in the specified surface finish.

Sanding gasket surfaces where edge-molded gaskets are used is most often unnecessary. Edge-molded gaskets are those metal carriers with sealing material bonded to the edges of the gasket to seal while the metal portion forms a metal to metal joint for stability. Any of the small amounts of sealing material that can stick to the parts are better removed with a blunt-edged scraper on the spots rather than spending time polishing the whole surface with an air sander or disc.

For those gaskets that do **not** have the edge molding, nearly all have a material that contains release agents to prevent sticking. Certainly this is **not** to say that some gaskets are **not** difficult to remove because the gasket has been in place a long time, has been overheated or the purpose of the release agent has been defeated by the application of some sealant. The object however is just to remove the gasket without damaging the surfaces of the mating parts without contaminating the engine (don't let the little bits fall where they can not be removed).

Bead blasting piston crowns until the dark stain is removed is unnecessary. All that is required is to remove the carbon build-up above the top ring and in the ring grooves. There is more information on bead blasting and piston cleaning later in this document.

Cummins Inc. does **not** recommend sanding or grinding the carbon ring at the top of cylinder liners until clean metal is visible. The liner will be ruined and any signs of a problem at the top ring reversal point (like a dust-out) will be destroyed. It is necessary to remove the carbon ring to provide for easier removal of the piston assembly. A medium bristle, high quality, steel wire wheel that is rated above the rpm of the power tool being used will be just as quick and there will be less damage. Yes, one **must** look carefully for broken wires after the piston is removed but the wires are more visible and can be attracted by a magnet.

Oil on parts that have been removed from the engine will attract dirt in the air. The dirt will adhere to the oil. If possible, leave the old oil on the part until it is ready to be cleaned, inspected and installed, and then clean it off along with any attracted dirt. If the part is cleaned then left exposed it can have to be cleaned again before installation. Make sure parts are lubricated with clean oil before installation. They do **not** need to be oiled all over but do need oil between moving parts (or a good lube system priming process conducted before cranking the engine).

Bead blasting parts to remove exterior paint is also usually unnecessary. The part will most likely be painted again so all that needs happen is remove any loose paint.

Abrasive Pads and Abrasive Paper

The keyword here is "abrasive". There is no part of an engine designed to withstand abrasion. That is they are all supposed to lock together or slide across each other. Abrasives and dirt particles will degrade both functions.

▲ WARNING ▲

Abrasive material must be kept out of or removed from oil passages and parts wear points. Abrasive material in oil passages can cause bearing and bushing failures that can progress to major component damage beyond reuse. This is particularly true of main and rod bearings.

Cummins Inc. does **not** recommend the use of emery cloth or sand paper on any part of an **assembled** engine or component including but **not** limited to removing the carbon ridge from cylinder liners or to clean block decks or counterbores.

Great care **must** be taken when using abrasive products to clean engine parts, particularly on partially assembled engines. Abrasive cleaning products come in many forms and sizes. All of them contain aluminum oxide particles, silicon carbide, or sand or some other similar hard material. These particles are harder than most of the parts in the engine. Since they are harder, if they are pressed against softer material they will either damage the material or become embedded in it. These materials fall off the holding media as the product is used. If the products are used with power equipment the particles are thrown about the engine. If the particles fall between two moving parts, damage to the moving parts is likely.

If particles that are smaller than the clearance between the parts while they are at rest (engine stopped), but larger than the running clearance then damage will occur when the parts move relative to each other (engine started). While the engine is running and there is oil pressure, particles that are smaller than the bearing clearance are likely to pass between the parts without damage and be trapped in the oil filter. However, particles larger than the bearing clearance will remove material from one part and can become embedded in one of the parts. Once embedded in one part it will

abrade the other part until contact is no longer being made between the two parts. If the damage sufficiently degrades the oil film, the two parts will come into contact resulting in early wear-out or failure from lack of effective lubrication.

Abrasive particles can fly about during cleaning it is **very** important to block these particles from entering the engine as much as possible. This is particularly true of lubricating oil ports and oil drilling holes, especially those located downstream of the lubricating oil filters. Plug the holes instead of trying to blow the abrasive particles and debris with compressed air because the debris is often simply blown further into the oil drilling.

All old gasket material **must** be removed from the parts gasket surfaces. However, it is **not** necessary to clean and polish the gasket surface until the machining marks are erased. Excessive sanding or buffing can damage the gasket surface. Many newer gaskets are of the edge molded type (a steel carrier with a sealing member bonded to the steel). What little sealing material that can adhere is best removed with a blunt-edged scraper or putty knife. Cleaning gasket surfaces where an edge-molded gasket is used with abrasive pads or paper is usually a waste of time.

▲ WARNING ▲

Excessive sanding or grinding the carbon ring from the top of the cylinder liners can damage the liner beyond reuse. The surface finish will be damaged and abrasive particles can be forced into the liner material which can cause early cylinder wear-out or piston ring failures.

Tape off or plug all openings to any component interior before using abrasive pads or wire brushes. If really necessary because of time to use a power tool with abrasive pads, tape the oil drillings closed or use plug and clean as much of the surface as possible with the tool but clean around the oil hole/opening by hand so as to prevent contamination of the drilling. Then remove the tape or plug and clean the remaining area carefully and without the tool. **DO NOT** use compressed air to blow the debris out of oil drilling on an assembled engine! More likely than **not**, the debris can be blown further into the drilling. Using compressed air is fine if both ends of the drilling are open but that is rarely the case when dealing with an assembled engine.

Gasket Surfaces

The object of cleaning gasket surfaces is to remove any gasket material, not refinish the gasket surface of the part.

Cummins Inc. does **not** recommend any specific brand of liquid gasket remover. If a liquid gasket remover is used, check the directions to make sure the material being cleaned will **not** be harmed.

Air powered gasket scrapers can save time but care must be taken to **not** damage the surface. The angled part of the scraper must be against the gasket surface to prevent the blade from digging into the surface. Using air powered gasket scrapers on parts made of soft materials takes skill and care to prevent damage.

Do **not** scrape or brush across the gasket surface if at all possible.

Solvent and Acid Cleaning

Several solvent and acid-type cleaners can be used to clean the disassembled engine parts (other than pistons. See Below). Experience has shown that the best results can be obtained using a cleaner that can be heated to 90° to 95° Celsius (180° to 200° Fahrenheit). Kerosene emulsion based cleaners have different temperature specifications, see below. A cleaning tank that provides a constant mixing and filtering of the cleaning solution will give the best results. Cummins Inc. does not recommend any specific cleaners. Always follow the cleaner manufacturer's instructions. Remove all the gasket material, o-rings, and the deposits of sludge, carbon, etc., with a wire brush or scraper before putting the parts in a cleaning tank. Be careful not to damage any gasket surfaces. When possible, steam clean the parts before putting them in the cleaning tank.

▲ WARNING ▲

When using solvents, acids, or alkaline materials for cleaning, follow the manufacturers recommendations for use. Wear goggles and protective clothing to reduce the possibility of personal injury.

Experience has shown that kerosene emulsion based cleaners perform the best to clean pistons. These cleaners should **not** be heated to temperature in excess of 77°C (170°F). The solution begins to break down at temperatures in excess of 82°C (180°F) and will be less effective.

Do **not** use solutions composed mainly of chlorinated hydrocarbons with cresols, phenols and/or cresylic components. They often do **not** do a good job of removing deposits from the ring groove and are costly to dispose of properly.

Solutions with a pH above approximately 9.5 will cause aluminum to turn black; therefore do **not** use high alkaline solutions.

Chemicals with a pH above 7.0 are considered alkaline and those below 7.0 are acidic. As you move further away from the neutral 7.0, the chemicals become highly alkaline or highly acidic.

Remove all the gasket material, o-rings, and the deposits of sludge, carbon, etc., with a wire brush or scraper before putting the parts in a cleaning tank. Be careful to **not** damage any gasket surfaces. When possible use hot high

pressure water or steam clean the parts before putting them in the cleaning tank. Removing the heaviest dirt before placing in the tank will allow the cleaner to work more effectively and the cleaning agent will last longer.

Rinse all the parts in hot water after cleaning. Dry completely with compressed air. Blow the rinse water from all the capscrew holes and the oil drillings.

If the parts are **not** to be used immediately after cleaning, dip them in a suitable rust proofing compound. The rust proofing compound **must** be removed from the parts before assembly or installation on the engine.

Steam Cleaning

Steam cleaning can be used to remove all types of dirt that can contaminate the cleaning tank. It is a good method for cleaning the oil drillings and coolant passages

⚠ WARNING ⚠

When using a steam cleaner, wear safety glasses or a face shield, as well as protective clothing. Hot steam can cause serious personal injury.

Do **not** steam clean the following components:

- Electrical Components
- Wiring Harnesses
- Injectors
- Fuel Pump
- Belts and Hoses
- Bearings (ball or taper roller)
- Electronic Control Module (ECM)
- ECM Connectors
- Dosing Control Unit

Plastic Bead Cleaning

Cummins Inc. does **not** recommend the use of glass bead blast or walnut shell media on **any** engine part. Cummins Inc. recommends using **only** plastic bead media, Part Number 3822735 or equivalent on any engine part. **Never** use sand as a blast media to clean engine parts. Glass and walnut shell media when **not** used to the media manufacturer's recommendations can cause excess dust and can embed in engine parts that can result in premature failure of components through abrasive wear.

Plastic bead cleaning can be used on many engine components to remove carbon deposits. The cleaning process is controlled by the use of plastic beads, the operating pressure and cleaning time.

⚠ CAUTION ⚠

Do not use bead blasting cleaning methods on aluminum pistons skirts or the pin bores in any piston, piston skirt or piston crown. Small particles of the media will embed in the aluminum or other soft metal and result in premature wear of the cylinder liner, piston rings, pins and pin bores. Valves, turbocharger shafts, etc., can also be damaged. Follow the cleaning directions listed in the procedures.

⚠ CAUTION ⚠

Do not contaminate wash tanks and tank type solvent cleaners with the foreign material and plastic beads. Remove the foreign material and plastic beads with compressed air, hot high pressure water or steam before placing them in tanks or cleaners. The foreign material and plastic beads can contaminate the tank and any other engine parts cleaned in the tank. Contaminated parts may cause failures from abrasive wear.

Plastic bead blasting media, Part Number 3822735, can be used to clean all piston ring grooves. Do **not** use any bead blasting media on piston pin bores or aluminum skirts.

Follow the equipment manufacturer's cleaning instructions. Make sure to adjust the air pressure in the blasting machine to the bead manufacturer's recommendations. Turning up the pressure can move material on the part and cause the plastic bead media to wear out more quickly. The following guidelines can be used to adapt to manufacturer's instructions:

1. Bead size: U.S. size Number 16 — 20 for piston cleaning with plastic bead media, Part Number 3822735
2. Operating Pressure — 270 kPa (40 psd) for piston cleaning. Pressure should not cause beads to break.
3. Steam clean or wash the parts with solvent to remove all of the foreign material and plastic beads after cleaning. Rinse with hot water. Dry with compressed air.

⚠ CAUTION ⚠

The bead blasting operation must not disturb the metal surface. If the metal surface is disturbed the engine can be damaged due to increased parts clearance or inadequate surface finish on parts that move against other parts.

When cleaning pistons, it is **not** necessary to remove all the dark stain from the piston. All that is necessary is to remove the carbon on the rim and in the ring grooves. This is best done by directing the blast across the part as opposed to straight at the part. If the machining marks are disturbed by the blasting process, then the pressure is too high or the blast is being held on one spot too long. The blast operation **must not** disturb the metal surface.

Walnut shell bead blast material is sometimes used to clean ferrous metals (iron and steel). Walnut shell blasting produces a great amount of dust particularly when the pressure or the air pressure on the blasting machine is increased above media manufacturer's recommendation. Cummins Inc. recommends **not** using walnut shell media to clean engine parts due to the risk media embedment and subsequent contamination of the engine.

Cummins Inc. now recommends glass bead media **NOT** used to clean any engine parts. Glass media is too easily embedded into the material particularly in soft materials and when air pressures greater than media manufacturer's recommendation are used. The glass is an abrasive so when it is in a moving part, that part is abrading all the parts in contact with it. When higher pressures are used the media is broken and forms a dust of a very small size that floats easily in the air. This dust is very hard to control in the shop, particularly if **only** compressed air (and not hot water) is used to blow the media after it is removed from the blasting cabinet (blowing the part off inside the cabinet may remove large accumulations but never removes all the media).

Bead blasting is best used on stubborn dirt/carbon build-up that has **not** been removed by first steam/higher pressure washing then washing in a heated wash tank. This is particularly true of pistons. Steam and soak the pistons first then use the plastic bead method to safely remove the carbon remaining in the grooves (instead of running the risk of damaging the surface finish of the groove with a wire wheel or end of a broken piston ring. Make sure the parts are dry and oil free before bead blasting to prevent clogging the return on the blasting machine.

Always direct the bead blaster nozzle "across" rather than directly at the part. This allows the bead to get under the unwanted material. Keep the nozzle moving rather than hold on one place. Keeping the nozzle directed at one-place too long causes the metal to heat up and be moved around. Remember that the spray is **not** just hitting the dirt or carbon. If the machining marks on the piston groove or rim have been disturbed then there has **not** been enough movement of the nozzle and/or the air pressure is too high.

Never bead blast valve stems. Tape or use a sleeve to protect the stems during bead blasting. Direct the nozzle across the seat surface and radius rather than straight at them. The object is to remove any carbon build up and continuing to blast to remove the stain is a waste of time.

Acronyms and Abbreviations

General Information

The following list contains some of the acronyms and abbreviations used in this manual.

API	American Petroleum Institute
ASTM	American Society of Testing and Materials
°C	Celsius
CARB	California Air Resources Board
C.I.D.	Cubic Inch Displacement
CNG	Compressed Natural Gas
CPL	Control Parts List
cSt	Centistokes
ECM	Electronic Control Module
EGR	Exhaust Gas Recirculation
EPA	Environmental Protection Agency
°F	Fahrenheit
FMI	Failure Mode Identifier
GVW	Gross Vehicle Weight
LPG	Liquefied Petroleum Gas
Hg	Mercury
hp	Horsepower
H₂O	Water
ICM	Ignition Control Module
km/l	Kilometers per Liter
kPa	Kilopascal
LNG	Liquid Natural Gas
LTA	Low Temperature Aftercooling
MPa	Megapascal
mph	Miles Per Hour
mpq	Miles Per Quart
N•m	Newton-meter
NG	Natural Gas
OEM	Original Equipment Manufacturer
PID	Parameter Identification Descriptions
ppm	Parts Per Million
psi	Pounds Per Square Inch
PTO	Power Takeoff
rpm	Revolutions Per Minute
SAE	Society of Automotive Engineers
SCA	Supplemental Coolant Additive
STC	Step Timing Control
SID	Subsystem Identification Descriptions
VS	Variable Speed
VSS	Vehicle Speed Sensor

Section E - Engine Identification

Section Contents

	Page
Engine Diagrams	E-4
Engine Views.....	E-4
Engine Identification	E-1
Air Compressor.....	E-3
Cummins® Engine Nomenclature.....	E-2
ECM Dataplate.....	E-3
Engine Dataplate.....	E-1
Fuel Injection Pump Dataplate.....	E-2

This Page Left Intentionally Blank

Engine Identification

Engine Dataplate

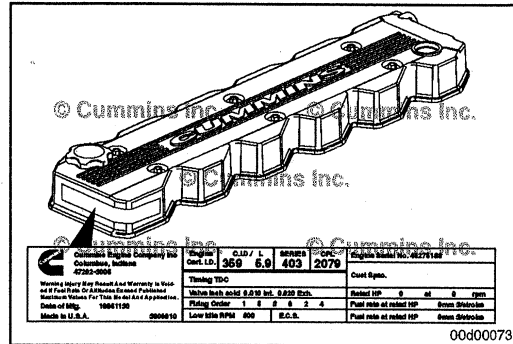
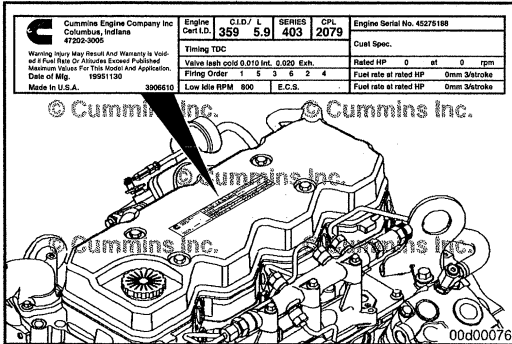

The engine dataplate shows specific facts about your engine. The dataplate is typically located on the engine rocker lever cover, but may also be located on the side of the gear housing. The engine serial number and CPL provide data for ordering parts and service. The engine dataplate **must not** be changed unless approved by Cummins Inc.

Have the following engine data available when communicating with a Cummins® Authorized Repair Location. The information on the dataplate is **mandatory** when sourcing service parts.

NOTE: The engines covered by this manual are produced worldwide. The data plates used on engines may differ in appearance and location of information. The following illustrations show examples of common data plates used and the information contained on the data plate.

MANUFACTURED BY CUMMINS INC. Assembled in the USA Date of Mfg: WARNING: Injury may result and warranty is voided if fuel rate, rpm or altitudes exceed published maximum values for this model and application.	Engine No.	Ref. No.	MODEL	Fuel Rate at Adv. HP	Min ³ Stroke	CPL
	Idle Speed (rpm)	Advertised HP	at rpm	Family	FEL EPA	CARB
	Firing Order	Timing T.D.C. ELECTRONIC	Catalyst No.	NOx+NMHC	PM	CARB
	Valve lash cold int. Exh. C.I.D./L / E.C.S.	IMPORTANT ENGINE INFORMATION: This engine is exempt from the prohibitions of section 203 (a) (1) (3) & (4) of the Clean Air Act as amended. See Exemption Label information for Exemption No. And Effective Date.				
	1	2	3	4	5	6

1. Engine serial number
2. Engine model information
3. Control parts list (CPL)
4. Valve lash (overhead) setting
5. Horsepower and rpm rating.

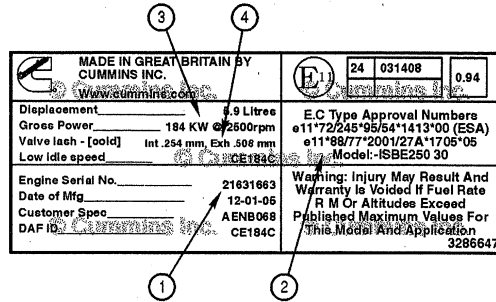

1. Engine serial number
2. Engine model information
3. Horsepower and rpm rating
4. Valve lash (overhead) setting.

08d00271

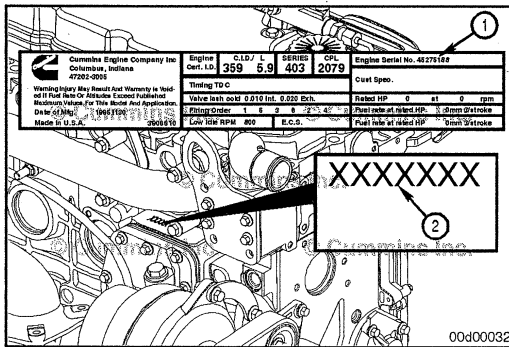

NOTE: If the engine dataplate (1) is **not** readable, the engine serial number (2) can be identified on the engine block on top of the lubricating oil cooler housing. Additional engine information is available by reading the ECM dataplate.

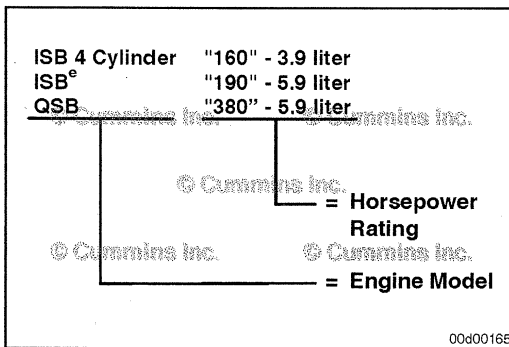

Cummins® Engine Nomenclature

The Cummins® engine nomenclature provides the data as illustrated in the graphic.

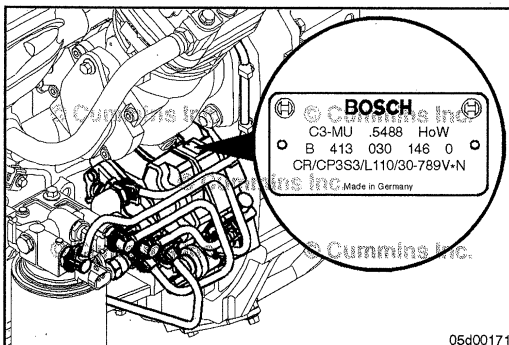

Fuel Injection Pump Dataplate

The Bosch® fuel injection pump dataplate is located on the fuel pump. The dataplate contains the following information which will assist in servicing or replacement:

- Pump serial number
- Cummins part number
- Factory code
- Bosch® part number
- Date code.

ECM Dataplate

The electronic control module (ECM) dataplate shows information about the ECM and how the ECM was programmed. The dataplate is located on the ECM.

The following information is available on the ECM dataplate:

- ECM part number (PN)
- ECM serial number (SN)
- ECM date code (DC)
- Engine serial number (ESN)
- ECM code: Identifies the software in the ECM.

NOTE: Have the ECM code for your engine available when communicating with a Cummins® Authorized Repair Location.

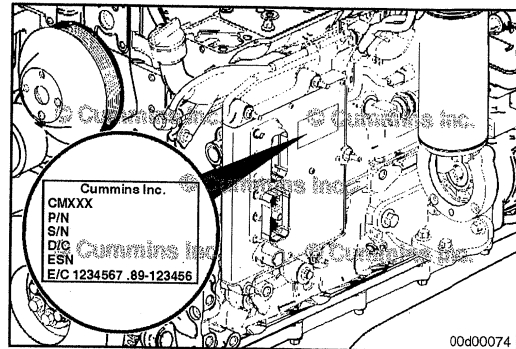

Air Compressor

NOTE: Not all engines are equipped with an air compressor.

The Cummins® branded air compressor dataplate, identified by the Cummins Inc. logo, is typically located on the side of the air compressor. The dataplate contains the following information which will assist in servicing or replacement:

- Cummins part number
- Serial number
- Date code.

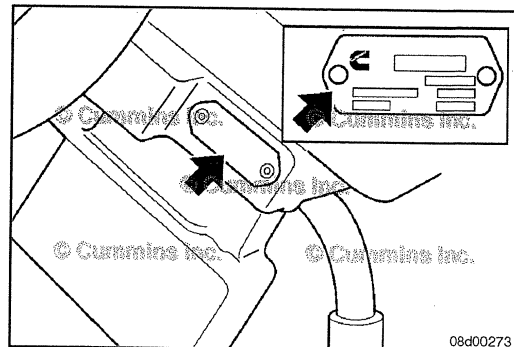

Engine Diagrams

Engine Views

The following illustrations show the locations of the major external engine components, filters, and other service and maintenance points. Some external components will be at different locations for different engine models.

NOTE: The illustrations are **only** a reference to show a typical engine.

Engine Diagrams

Engine Views

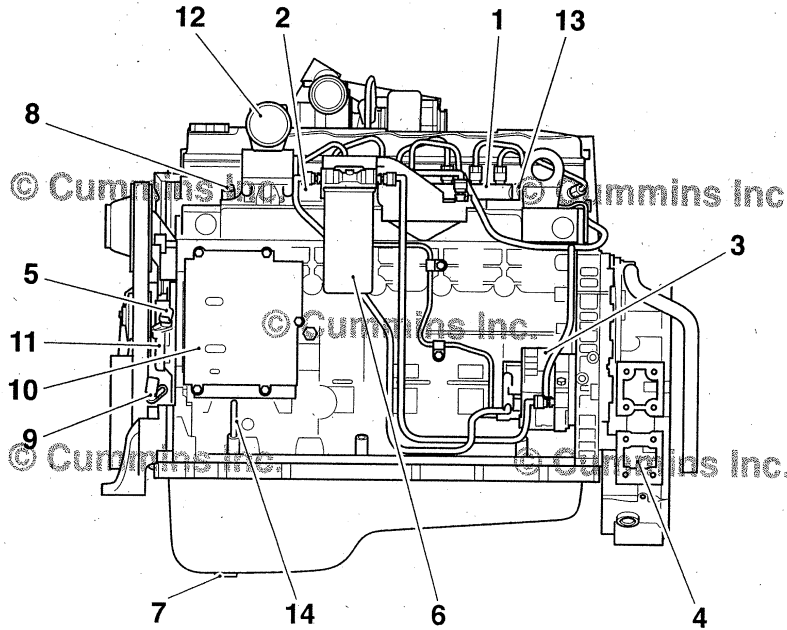

QSB 6.7 Engine Air Intake Side View

00d00184

1. Fuel rail
2. Intake pressure and temperature sensor
3. Bosch® fuel pump
4. Flywheel housing
5. Oil pressure switch
6. Fuel filter
7. Oil pan drain plug
8. Barometric pressure sensor
9. Engine speed sensor (crankshaft)
10. Electronic control module
11. Engine position sensor (camshaft)
12. Air intake inlet
13. Rail pressure sensor
14. Dipstick

Engine Diagrams

Engine Views

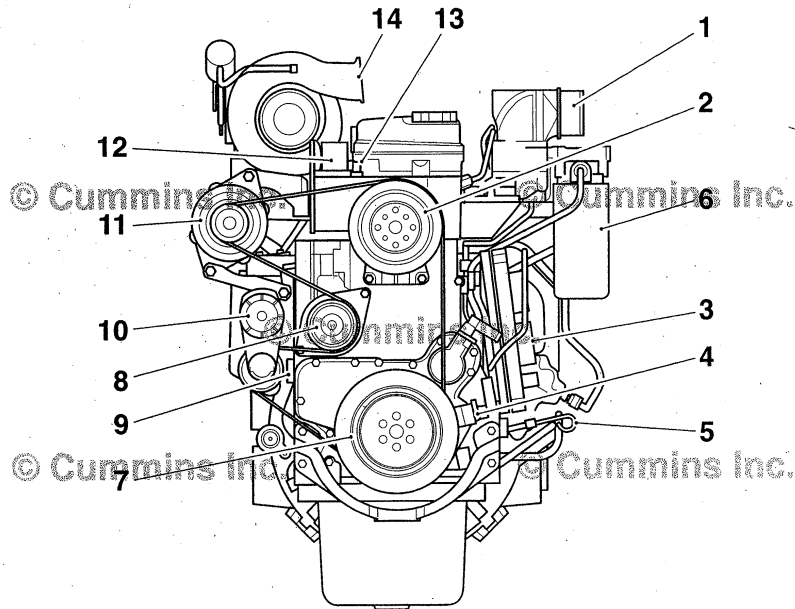

00d00185

QSB6.7 Engine Front View

1. Air inlet
2. Fan drive
3. Electronic control module
4. Engine speed sensor (crankshaft)
5. Dipstick
6. Fuel filter
7. Vibration damper
8. Water pump
9. Starter
10. Belt tensioner
11. Alternator
12. Coolant outlet
13. Coolant temperature sensor
14. Turbocharger air outlet

Engine Diagrams

Engine Views

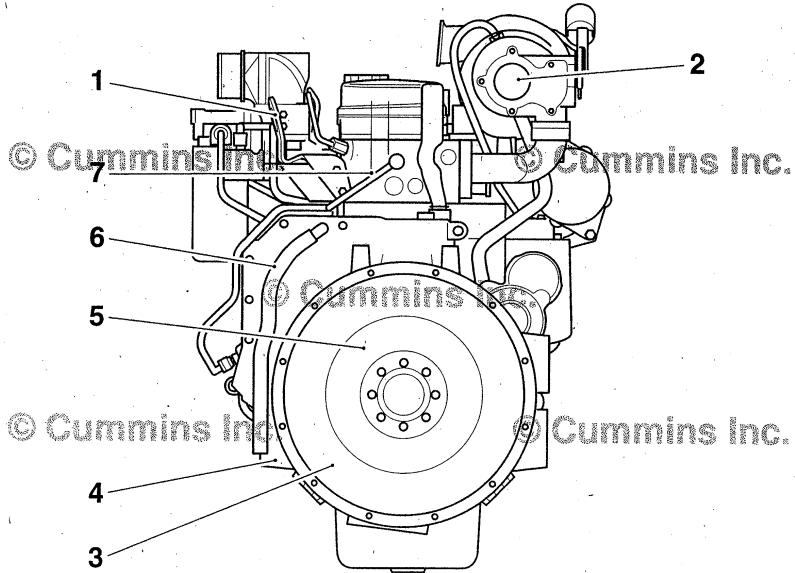

QSB6.7 Engine Rear View

00d00187

1. Rear engine lifting bracket
2. Turbocharger exhaust outlet
3. Clutch mounting holes
4. Flywheel housing
5. Flywheel/flexplate
6. Crankcase breather tube
7. Injector drain line

Engine Diagrams

Engine Views

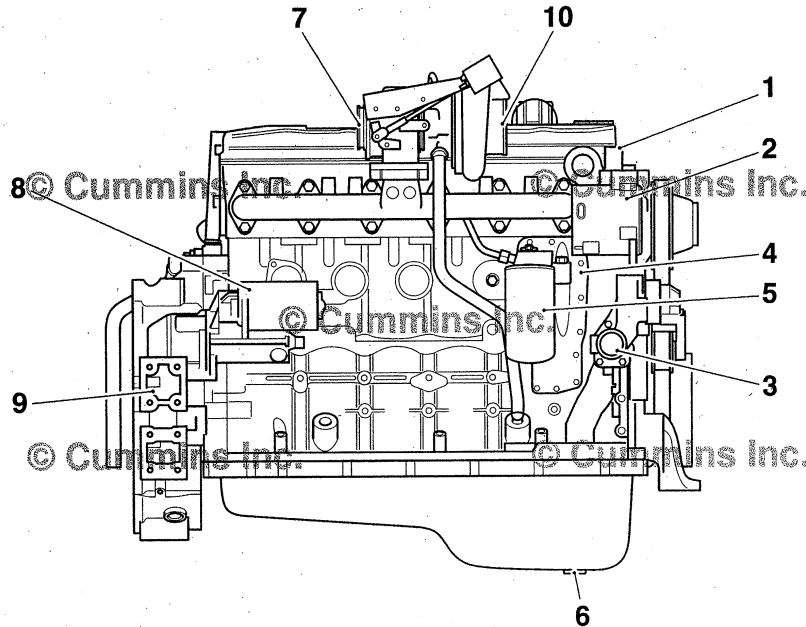

00400186

QSB6.7 Engine Exhaust Side View

1. Coolant outlet
2. Alternator
3. Coolant inlet
4. Lubricating oil cooler
5. Oil filter
6. Oil pan drain plug
7. Turbocharger exhaust outlet
8. Starter
9. Flywheel housing
10. Turbocharger compressor inlet.

Engine Diagrams

Engine Views

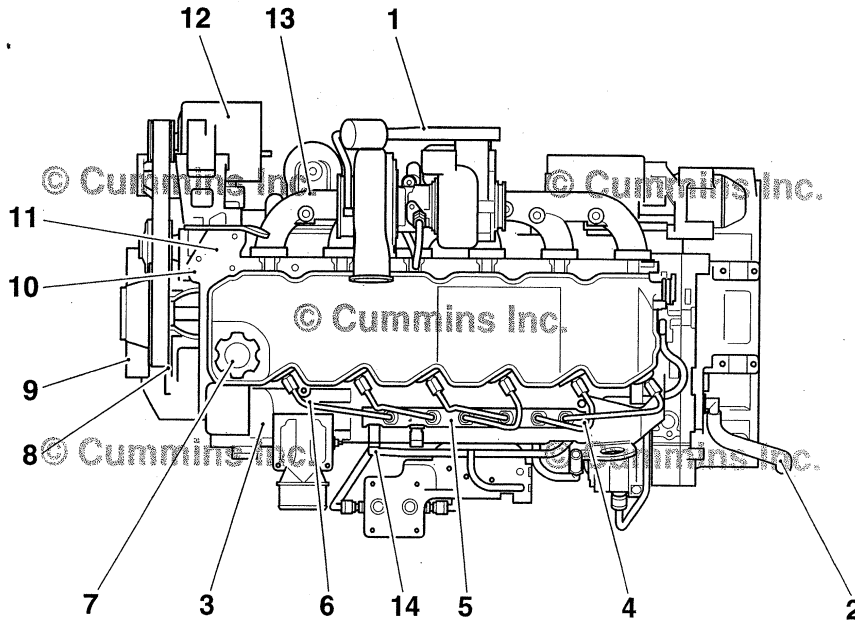

00d00183

QSB 6.7 Engine Top View

1. Turbocharger wastegate
2. Crankcase breather
3. Barometric pressure/temperature sensor
4. Fuel rail pressure sensor
5. Fuel rail
6. High-pressure fuel lines
7. Oil fill cap
8. Tone wheel
9. Vibration damper
10. Coolant temperature sensor
11. Coolant outlet
12. Alternator
13. Exhaust manifold
14. Rail pressure relief valve

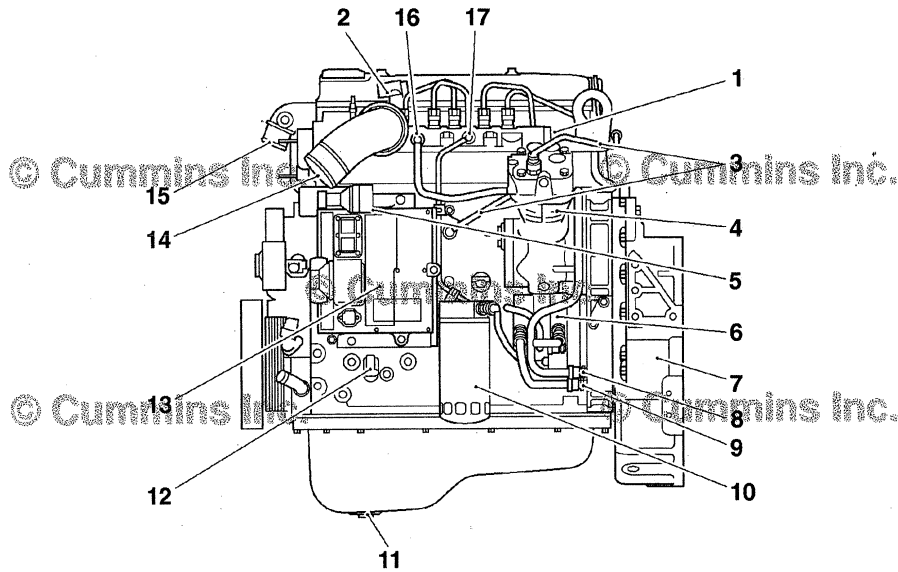

QSB4.5 Engine Air Intake Side View

00d00253

- | | |
|--|-------------------------------------|
| 1. Fuel rail pressure sensor | 10. Fuel filter |
| 2. Intake manifold pressure/temperature sensor | 11. Oil pan drain plug |
| 3. Air compressor cooling pipes | 12. Dipstick/oil level sensor |
| 4. Air compressor | 13. Electronic control module |
| 5. Ambient air pressure sensor | 14. Air intake inlet |
| 6. Bosch® fuel pump | 15. Coolant outlet |
| 7. Flywheel housing | 16. Fuel rail pressure relief valve |
| 8. Fuel return | 17. Fuel rail. |
| 9. Fuel inlet | |

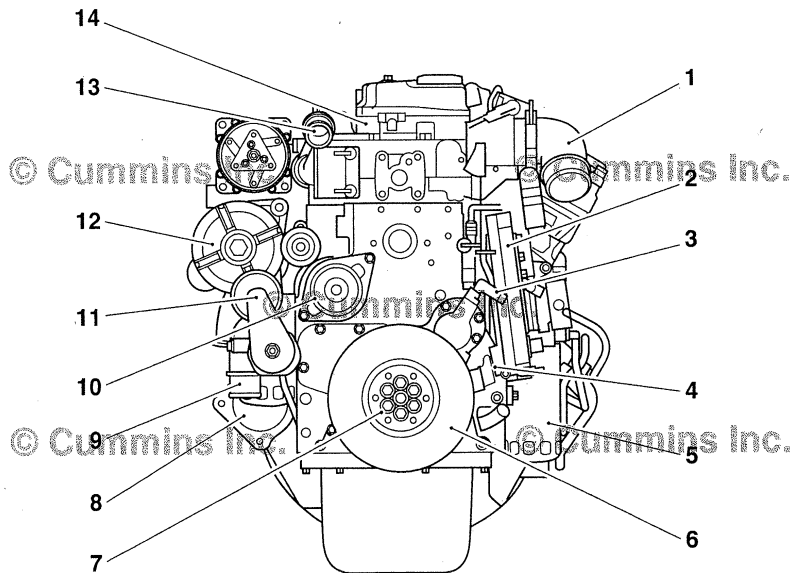

QSB4.5 Engine Front View

00d00215

1. Air inlet

QSB Series

Section E - Engine Identification

2. Electronic control module
3. Engine speed sensor (camshaft)
4. Engine speed sensor (crankshaft)
5. Fuel filter
6. Vibration damper (Optional)
7. Fan or PTO drive flange mounting
8. Starter mounting location
9. Coolant inlet
10. Water pump
11. Belt tensioner
12. Alternator
13. Coolant outlet
14. Coolant temperature sensor.

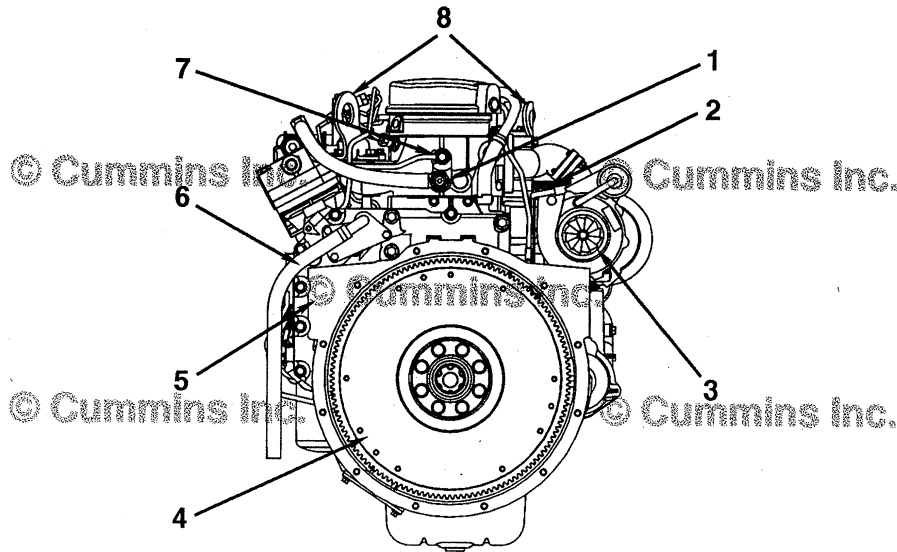

QSB4.5 Engine Rear View

00d00036

- | | |
|--|-----------------------------|
| 1. Coolant connection for air compressor | 5. Flywheel housing |
| 2. Air outlet from turbocharger | 6. Crankcase breather tube |
| 3. Air inlet to turbocharger | 7. Fuel return line |
| 4. Flywheel | 8. Engine lifting brackets. |

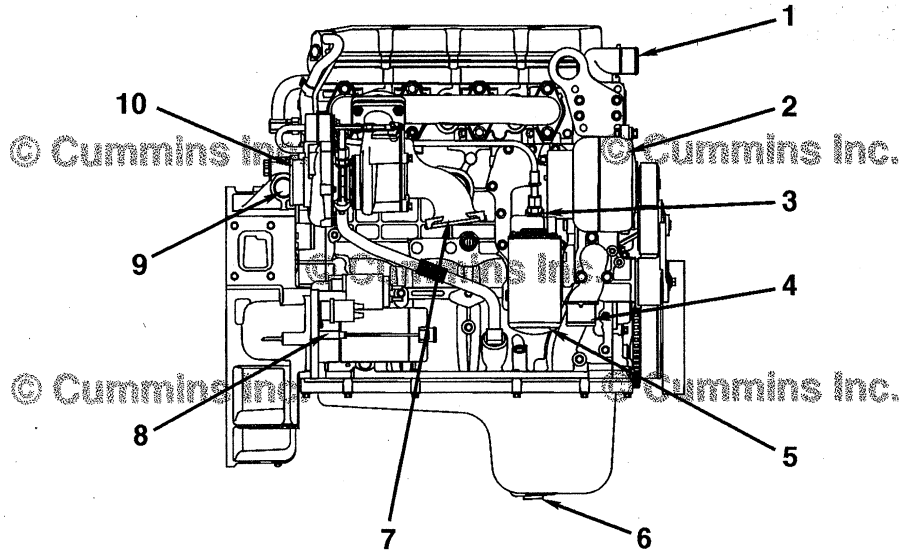

00d00038

QSB4.5 Engine Exhaust Side View

- | | |
|-------------------|------------------------------------|
| 1. Coolant outlet | 6. Oil pan drain plug |
| 2. Alternator | 7. Turbocharger exhaust outlet |
| 3. Oil cooler | 8. Starter |
| 4. Coolant inlet | 9. Flywheel housing |
| 5. Oil filter | 10. Turbocharger compressor inlet. |

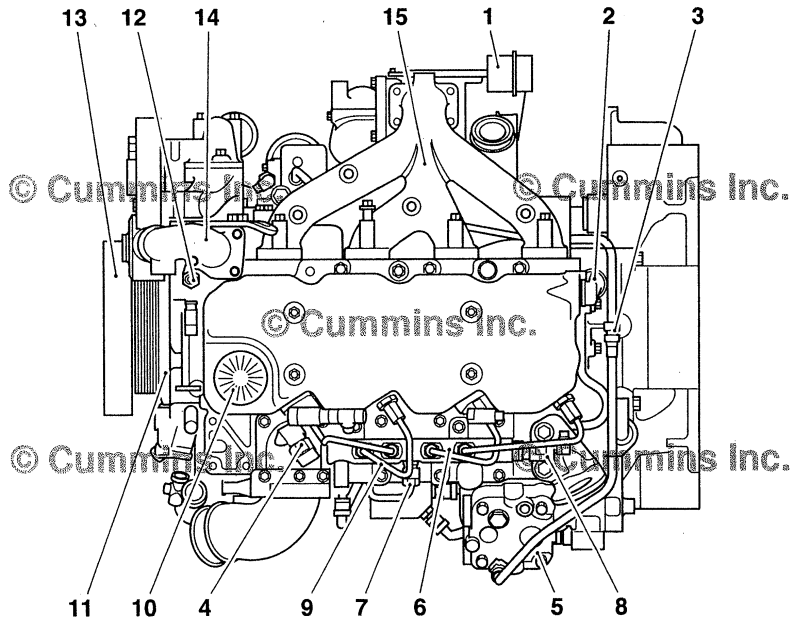

00d00217

QSB4.5 Engine Top View

- | | |
|--|---------------------------------|
| 1. Turbocharger wastegate actuator | 9. High-pressure fuel lines |
| 2. Crankcase breather | 10. Oil fill cap |
| 3. Air compressor coolant connection | 11. Tone wheel |
| 4. Intake manifold pressure/temperature sensor | 12. Coolant temperature sensor |
| 5. Air compressor | 13. Vibration damper (Optional) |

QSB Series
Section E - Engine Identification

- | | |
|---|-----------------------|
| 6. Fuel rail | 14. Coolant outlet |
| 7. High-pressure supply line (pump to rail) | 15. Exhaust manifold. |
| 8. Fuel rail pressure sensor | |



Section FB - Industrial Features

Section Contents

	Page
Accelerator Options	FB-3
Disadvantages.....	FB-3
Driver Activation/Deactivation.....	FB-3
Feature Description.....	FB-3
Interaction with other Features and Parameters.....	FB-3
Visual Aids.....	FB-3
Alternate Droop	FB-4
Disadvantages.....	FB-5
Driver Activation/Deactivation.....	FB-5
Feature Description.....	FB-4
Interaction with other Features and Parameters.....	FB-5
Visual Aids.....	FB-5
Automatic Boost Power	FB-7
Disadvantages.....	FB-7
Driver Activation/Deactivation.....	FB-7
Feature Description.....	FB-7
Interaction with other Features and Parameters.....	FB-7
Visual Aids.....	FB-7
Fan Control	FB-1
Disadvantages.....	FB-1
Driver Activation/Deactivation.....	FB-1
Feature Description.....	FB-1
Interaction with other Features and Parameters.....	FB-1
Visual Aids.....	FB-1
Fuel Consumption Rate Logger	FB-8
Disadvantages.....	FB-8
Driver Activation/Deactivation.....	FB-8
Feature Description.....	FB-8
Interaction with other Features and Parameters.....	FB-8
Visual Aids.....	FB-8
Hot Shutdown Monitor	FB-6
Disadvantages.....	FB-7
Driver Activation/Deactivation.....	FB-7
Feature Description.....	FB-6
Interaction with other Features and Parameters.....	FB-7
Visual Aids.....	FB-7
Idle Shutdown	FB-2
Disadvantages.....	FB-2
Driver Activation/Deactivation.....	FB-2
Feature Description.....	FB-2
Interaction with other Features and Parameters.....	FB-2
Visual Aids.....	FB-2
Intermediate Speed Control (ISC)	FB-3
Disadvantages.....	FB-4
Driver Activation/Deactivation.....	FB-4
Feature Description.....	FB-3
Interaction with other Features and Parameters.....	FB-4
Visual Aids.....	FB-4
Multiple Unit Synchronization	FB-5
Disadvantages.....	FB-6
Driver Activation/Deactivation.....	FB-6
Feature Description.....	FB-5
Interaction with other Features and Parameters.....	FB-6
Visual Aids.....	FB-6
Switchable (Alternate) Torque	FB-5
Disadvantages.....	FB-5
Driver Activation/Deactivation.....	FB-5

Feature Description.....	FB-5
Interaction with other Features and Parameters.....	FB-5
Visual Aids.....	FB-5
Water-in-Fuel Sensor	FB-1
Disadvantages.....	FB-2
Driver Activation/Deactivation.....	FB-2
Feature Description.....	FB-1
Interaction with other Features and Parameters.....	FB-2
Visual Aids.....	FB-2

Fan Control

Feature Description

Various fan control features are available and while **not** all aspects of fan control are available on all engines, most (but **not** all) electronic controlled engines have some Electronic Control Module (ECM) fan control capability.

Fan control capability means that the ECM is able to turn the fan on or off in response to any of the following inputs:

- Engine operating conditions (coolant temperature, intake manifold temperature, etc.)
- Control of fan overspeed
- Air conditioner operation
- Manual fan switch
- Engine performance requirements (Example: engine braking)

NOTE: Many Industrial engines have fan controls as part of the ECM calibration that can **not** be adjusted using the service tool.

Driver Activation/Deactivation

The driver can override the ECM to turn the fan on, using the manual fan switch installed in the cab by the vehicle manufacturer. When the driver places the manual fan switch in the ON position, the fan will be on regardless of other engine operating conditions. When the manual fan switch is in the OFF position, the fan will operate according to engine operating conditions and according to how the fan control parameters are configured.

Interaction with other Features and Parameters

ISB and ISC have a single pin on the ECM that provides Pulse Width Modulation. This pin can be used to send a kick-down signal to an automatic transmission, in which case it **must not** be used to operate a variable speed fan.

Disadvantages

Due to heat rejection, the fan on during engine braking feature will appear inconsistent to some vehicle operators (Example: Consider an ISX calibration setting that the fan will engage 15 seconds after engine braking starts. It will be possible for the fan to sometimes come on sooner in response to air intake temperatures, coolant temperatures, or the air conditioner pressure switch).

Visual Aids

1. Fan Type
2. Drive Ratio
3. Maximum Fan Speed
4. Air Conditioner Speed Control
5. Fan On During Engine Braking
6. Minimum Fan On Time for Air Conditioner Pressure Switch
7. Manual Fan Switch
8. Air Conditioner Pressure Switch
9. Pulse Width Modulation Frequency
10. Clutch Logic
11. Fan Clutch 2 Enable

Water-in-Fuel Sensor

Feature Description

The water-in-fuel sensor protects the fuel system by alerting the vehicle operator that water has accumulated in the fuel filter and this water **must** be drained. The operator will be warned of a high water condition by a flashing warning lamp on the dash.

The fuel filter removes emulsified and free water from the fuel as it passes through the filter media. The removed water is heavier than fuel and falls to the bottom of the filter canister where it accumulates. The water-in-fuel sensor is installed in the base of the fuel filter canister. The sensor consists of two metallic probes that sense the electrical conductivity of the surrounding solution. A change in conductivity can be detected when sufficient water accumulates around the probes and displaces the diesel fuel. When this happens the ECM lights the warning light on the dash and Fault Code 418, Water-In-Fuel Indicator High - Maintenance is logged.

Driver Activation/Deactivation

The driver can **not** activate or deactivate the water-in-fuel sensor feature. This feature can **only** be activated or deactivated by the Cummins INSITE™ service tool.

Interaction with other Features and Parameters

This feature does **not** interact with any other feature or parameter.

Disadvantages

None

Visual Aids

None

Idle Shutdown

Feature Description

The idle shutdown feature reduces the amount of fuel burned and increases engine life by shutting down the engine after a period of engine idling with no driver activity. Before the shutdown will occur a flashing warning lamp will warn the driver of an impending shutdown. The driver can override the shutdown by depressing the service brake, clutch or accelerator pedal during the warning period. This activity will override the idle shutdown. Idle shutdown operates when the engine is in the Power TakeOff (PTO) mode unless a specific load threshold is exceeded. Idle shutdown can be automatically overridden during cold ambient temperatures if equipped with an OEM supplied ambient air temperature sensor.

The following table indicates when manual and automatic overrides are available.

Driver Activation/Deactivation

The driver can **not** activate or deactivate the idle shutdown feature. This feature can **only** be activated or deactivated by the Cummins INSITE™ service tool.

To override the automatic idle shutdown the driver will need to activate the brake, clutch or accelerator pedal during the 30 second period prior to shutdown. 30 seconds prior to the shutdown a flashing warning lamp will notify the driver that engine shutdown is pending. This action will override idle shutdown. If the override is successful the warning lamp will flash every one half second for two minutes.

Interaction with other Features and Parameters

Idle shutdown can interact with the PTO feature. Idle shutdown can cause the engine to shutdown when in PTO mode. If the idle shutdown percent load threshold is **not** exceeded the engine will be shutdown.

It is required that this feature be enabled with the ICON™ product and the ambient air temperature override **must** be disabled.

Disadvantages

The idle shutdown feature will **not** activate if Fault Code 241 is active.

When stopped in traffic for extended periods the engine will be shutdown.

Visual Aids

The chart below indicates when manual and automatic overrides are available.

	Manual Override	Automatic Override
Below Cold Air Temperature	No	Yes
Between Cold Air and Intermediate Air Temperature	Yes	No
Between Intermediate Air and Hot Air Temperature	No	Yes
Above Hot Air Temperature	Yes	No

Accelerator Options

Feature Description

This feature allows the user to determine the type of engine governor control. The two types available are the automotive (minimum or maximum) and Variable Speed or All Speed Governor types. The automotive governor provides a constant fueling for a given accelerator position. With the automotive governor selected the engine speed can vary with changes in engine loading for a constant accelerator position.

The Variable Speed governor provides a constant engine speed for a given accelerator position. With the Variable Speed governor selected the engine speed will remain constant with changes in engine loading for a constant accelerator position. The Variable Speed governor is an option. It is best suited for applications where a constant engine speed is desired to perform a desired task where engine or power take-off speed **must** remain constant.

Driver Activation/Deactivation

The selection of the governor type can be accomplished two ways. If the vehicle is equipped with a cab-mounted switch, the driver can activate this switch to select between the automotive or Variable Speed governor. If the cab switch is **not** available the INSITE™ service tool can be used to select the desired governor type.

Interaction with other Features and Parameters

This feature does **not** interact with any other feature or parameter.

Disadvantages

For applications that require a constant engine speed to perform a desired task, the automotive governor will **not** hold the engine or Power Take-Off speed constant for a given accelerator position.

Visual Aids

None

Intermediate Speed Control (ISC)

Feature Description

Industrial applications use an engine speed control feature called Intermediate Speed Control.

Up to three Intermediate Speed Control Set Speeds (1, 2, or 3) can be selected depending on Original Equipment Manufacturer (OEM) availability. To support this feature, a multi-position switch, or three toggle switches **must** be installed by the OEM.

Additionally, up to five Variable Intermediate Speed Control Set speeds (1, 2, 3, 4, or 5) can be selected and the operator can select these speeds using an OEM installed accelerator lever.

The Intermediate Speed Control set speeds will interact with the accelerator pedal in one of three different ways (modes A, B and C); the interaction between Intermediate Speed Control set speeds and the accelerator pedal is **not** adjustable, this interaction is determined by the OEM and built into the ECM calibration.

Mode A - Intermediate Speed Control set speed acts as low speed governor. In this mode, the Intermediate Speed Control set speed becomes the Minimum Engine Speed. The operator can use the accelerator pedal to increase the speed above the Intermediate Speed Control set speed.

Mode B - Intermediate Speed Control set speed acts as high speed governor. In this mode, the Intermediate Speed Control set speed becomes the Maximum Engine Speed. The operator can use the accelerator pedal to control engine speed up to the Intermediate Speed Control set speed.

Mode C - Intermediate Speed Control Constant Speed. In this mode, the Intermediate Speed Control runs at constant speed and accelerator pedal input is ignored.

The three Preset Intermediate Speed Control speeds can be adjusted with an increment or decrement switch and are INSITE™ service tool adjustable, but can **not** exceed the low or high idle governor engine speed limits.

The five Intermediate Speed Control Variable Speed Control set speeds are **not** adjustable with the increment or decrement switch, but are adjustable with the INSITE™ service tool.

Only one droop setting is available for all Intermediate Speed Control speeds.

One of the switch inputs can be used as a validation input (if used, the ECM pin for Intermediate Speed Control 3 will be used). If this is the case, the ECM calibration will use the ECM pin used for Intermediate Speed Control 3 as a

validation input and **only 2** Intermediate Speed Control speeds will be available while the five variable Intermediate Speed Control inputs will **not** be available.

If more than one Intermediate Speed Control switches is turned ON; the lowest speed turned ON will take priority.

Driver Activation/Deactivation

Using the Intermediate Speed Control Switched Set Speeds

The operator can operate the engine using the Intermediate Speed Control Set Speeds with OEM installed Intermediate Speed Control Switches, or an equivalent OEM installed device. Activating Intermediate Speed Control can or can **not** cause Accelerator Pedal inputs to be ignored.

Using the Intermediate Speed Control Variable Speed Set Points

The operator can operate the engine using the Intermediate Speed Control Variable Speeds; Intermediate Speed Control Variable Speeds are selected with an Accelerator Lever or an equivalent switching device that is installed by the OEM. This device can contain a potentiometer that sends a variable signal to the ECM. Based on the output of the potentiometer, the engine will be controlled to one of five Intermediate Speed Control Variable Speeds. Refer to the figure below for visual reference. It is recommended that all five speeds be chosen and entered in a sequential order so that as the operator increases the position of the hand throttle, the engine speed will change accordingly.

Interaction with other Features and Parameters

Intermediate Speed Control and Cruise Control can **not** be active at the same time. If the cruise control on/off switch is on, then Intermediate Speed Control is disabled. If the cruise on/off switch is off then Intermediate Speed Control will remain off until an Intermediate Speed Control switch transitions from off to on.

Remote Throttle and Variable Speed Intermediate Speed Control **must not** both be used on the same engine.

Disadvantages

Using the service tool, it is **not** possible to display the interaction between Intermediate Speed Control and the throttle pedal.

Visual Aids

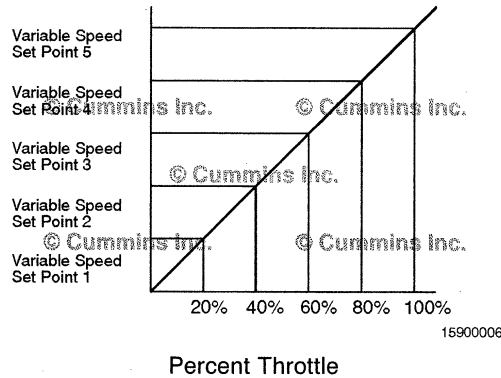

Alternate Droop

Feature Description

Alternate Droop allows the droop characteristics to be changed for the automotive (minimum or maximum) and for Variable Speed (VS) governor or All Speed Governor. In general less governor droop (lower percentage) provides a more responsive governor for more precise engine control. More governor droop (higher percentage) provides smoother shifting and smoother mechanical clutch engagement. This feature, depending on Original Equipment Manufacturer (OEM) availability, provides the user the ability to select multiple breakpoint speeds and the droops associated with those speeds by way of an OEM-provided switch.

Driver Activation/Deactivation

Alternate Droop is calibration activated (except for CELECT™ Plus), but uses a switch to toggle between the alternate droop settings. Depending on the application the alternate droop switch can be a 2 or 3 position switch. Toggling the switch into the 2nd and 3rd positions will activate the 2nd and 3rd droop settings accordingly.

Interaction with other Features and Parameters

The Vehicle Speed Droop feature uses the droop settings for this feature.

Disadvantages

- Driver complains of low power.
- Driver complains of poor or unexpected throttle reaction.

Visual Aids

1. Torque
2. Engine Speed (RPM)
3. Low Idle Speed
4. Maximum Torque Curve
5. High speed Break Point
6. Normal Droop
7. Alternate Droop
8. Alternate Droop (available)

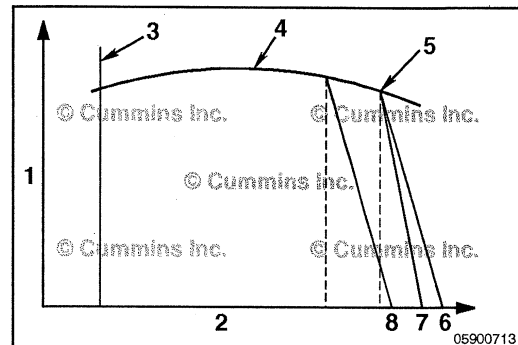

Switchable (Alternate) Torque

Feature Description

Switchable (Alternate) Torque provides derated torque curves other than the 100 percent torque curve. These torque curves are normally used to help limit the torque output of the engine and helps to protect driveline components such as axles and transmissions and in some cases can help protect the engine from damage.

Driver Activation/Deactivation

The operator can activate or deactivate the alternate torque curves through an OEM supplied switch.

Interaction with other Features and Parameters

None

Disadvantages

Possible operator complaints of low power

Visual Aids

None

Multiple Unit Synchronization

Feature Description

The multi unit synchronization feature allows two or more engines (up to a maximum of 11) to be controlled by a single throttle signal and run at a similar speed (See visual aids section). There is three engine configurations available with this feature: soft-coupled, hard-coupled, and soft-coupled marine.

The soft-coupled configuration has all secondary engines in parallel with each other. The primary engine outputs a throttle signal to all secondary engines. This setup allows all engines to remain running if a secondary engine stops running.

The hard-coupled configuration has the primary and all secondary engines in series with each other (See visual aids section). The primary engine outputs a throttle signal, which is received by the first secondary engine. This secondary

engine then outputs the throttle signal to the next secondary engine in the series. This process repeats until the primary engine receives the throttle signal.

The soft-coupled marine configuration has all secondary engines in parallel with each other (See visual aids section) The primary engine outputs a throttle signal on the J1939 datalink to all secondary engines.

Driver Activation/Deactivation

This feature can **not** be activated or deactivated by the driver except in the case of the soft-coupled marine configuration. In this case, Multi Unit Synchronization is turned on or off by a user activated switch.

Interaction with other Features and Parameters

None

Disadvantages

In the hard-coupled configuration, if one engine in the series stops running, then the remaining engines in the circuit will also stop running.

Visual Aids

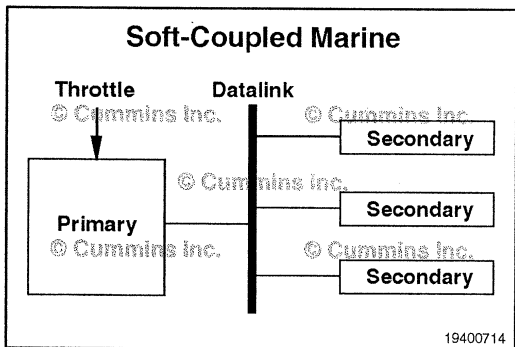
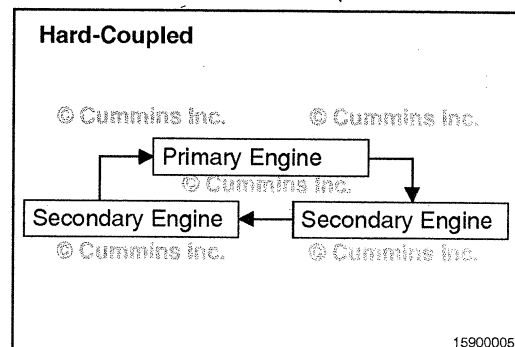
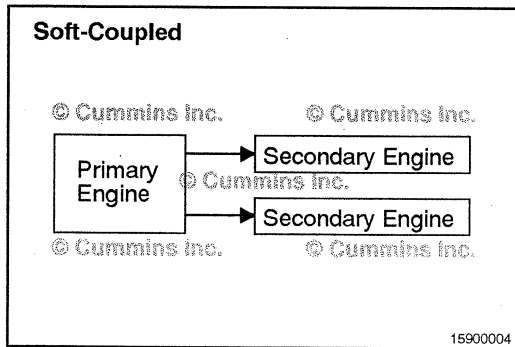

Hot Shutdown Monitor

Feature Description

The Hot Shutdown Monitor will log a fault in the Electronic Control Module (ECM) if the engine is shut down, either by the key switch or by the engine protection feature or other Original Equipment Manufacturer (OEM) devices, while still hot. The engine is considered hot if the load on the engine is above the hot shutdown minimum load set by Cummins INSITE™ electronic service tool. Hot shutdown monitor is available on QSB, QSC, QSL9, QSM11, QSX15, QST30, QSK19, QSK45, QSK50, QSK38, QSK78, and QSK60 industrial engines.

The hot shutdown load percent is based on the duty cycle load factor that is determined from engine fueling levels. For example: If the hot shutdown load percent is set at 60 percent, every time the engine is shut down when the calculated engine load is over 60 percent, a hot shutdown fault will be logged.

Driver Activation/Deactivation

There is no operator activation or deactivation for hot shutdown monitor.

Interaction with other Features and Parameters

None

Disadvantages

None

Visual Aids

None

Automatic Boost Power

Feature Description

Boost Power is a torque curve that is calibrated for a higher torque/horsepower than the normal engine rating and is available on QSB, QSC, CELECT™ Plus, QSM11, QSX15, QSK19, QSK45, and QSK60 industrial engines. The Electronic Control Module (ECM) will monitor engine speed, intake manifold temperature, and coolant temperature to determine if Boost Power can be activated. If Boost Power is available, the operator can activate Boost Power using a dash-mounted switch. The engine will switch to the higher torque curve or power rating for a limited period of time. The higher torque curve or power rating is calibrated for an intermittent or non-continuous torque or power rating which is higher than the normal torque or power rating for the engine. Boost power is **not** available if coolant temperature or intake manifold temperatures are above calibrated thresholds. If engine speed is below a calibrated threshold, then Boost Power will **not** be time limited.

Automatic Boost Power will provide the operator with enhanced torque or power for a fraction of the operating period. The ECM will monitor engine speed, intake manifold temperature, percent load, and coolant temperature to determine if automatic Boost Power can be activated. If automatic Boost Power is available, the engine will switch to the enhanced torque or power rating for a limited period of time. The Original Equipment Manufacturer (OEM) equipment users manual will document the time periods that automatic Boost Power is available, since it is application specific. Automatic Boost Power is **not** available if coolant temperature or intake manifold temperatures are above calibrated thresholds. If engine speed or percent load is below a calibrated threshold, automatic Boost Power will **not** be available. If coolant temperature or intake manifold temperature rise above calibrated threshold, then automatic Boost Power will be deactivated. Automatic Boost Power is available on QSB, QSC, QSM11, and QSX15 industrial engines.

Driver Activation/Deactivation

To activate Boost Power, the operator **must** turn on a dash-mounted switch. To deactivate Boost Power, the operator **must** turn the switch off. Boost power will engage if the engine operating conditions are There is no operator interaction to activate or deactivate automatic Boost Power.

Interaction with other Features and Parameters

Boost power **must** be enabled in order to enable automatic Boost Power.

Disadvantages

A possible customer complaint associated with this feature will be intermittent low power.

Boost Power **must not** engage due to the Boost Power load threshold is set above the highest load experienced during normal engine operation

Visual Aids

None

Fuel Consumption Rate Logger

Feature Description

Fuel Consumption Rate Logger is an industrial feature that monitors fuel usage over the life of the engine. The feature also maintains a bar graph (short term fuel consumption) that displays fuel consumption over the last 40 hours of engine operation. Fuel consumption is measured in Gallons Per Hour (gph).

The feature allows the following to be viewed under the Fuel Consumption Monitor heading with Cummins INSITE™:

Long Term Rate - Cumulative Fuel Economy (Gallons/Hour). The cumulative fuel economy is the fuel economy averaged over the life of the engine.

Long Term Time - Engine Hours Included in the calculation of the Long Term Rate

Instantaneous Rate - The instantaneous fuel economy (Gallons/Hour)

Short Term Rate - A graphical representation of fuel economy (Gallons/Hour) versus time (Hours). The graphical representation will span up to 40 hours of engine operation and display average fuel economy for each of the last 40 hours of engine operation.

Short Term Hour - Identifies which hour is being monitored in the current 40 hour period represented by the short term rate graphical display.

Hour Counter - Shows the minutes elapsed in the current hour being monitored.

If fuel consumption rate monitor is enabled, Cummins INSITE™ will display a bar graph representing fuel consumption for the last 40 hours of engine operation. The graphical display is a bar graph with engine hours on the horizontal axis and fuel consumption on the vertical axis. A maximum of 40 bars representing 40 hours of engine operation will be displayed; each bar represents fuel consumption averaged over one hour of engine operation. The graph will size itself to fit on the screen for easy viewing.

Driver Activation/Deactivation

None

Interaction with other Features and Parameters

None

Disadvantages

None

Visual Aids

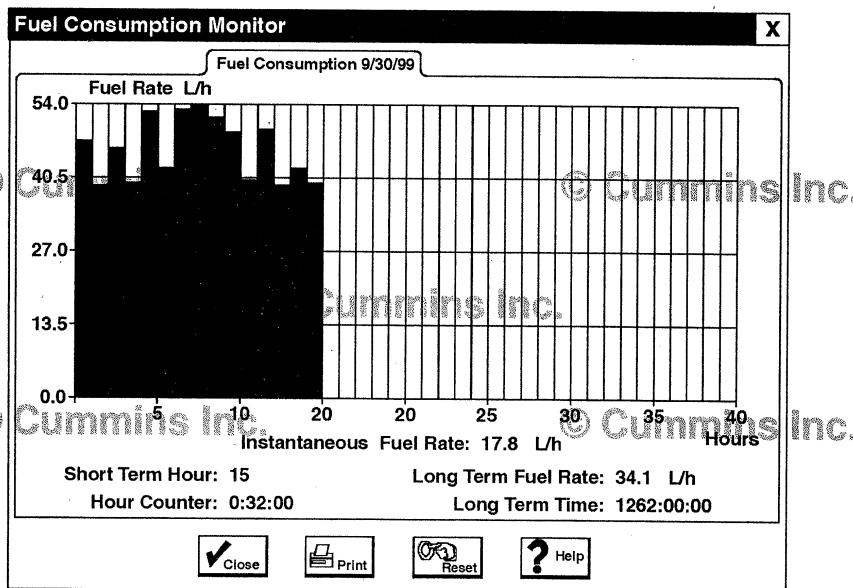

05400134

The Short Term Rate Logger has logged 15 hours of data since the last RESET, currently the engine has run for 32 minutes into the 16th hour of engine operation. The engine has averaged 34.1 L [1 hour] over its life.



This Page Left Intentionally Blank

Section 1 - Operating Instructions

Section Contents

	Page
Cold Weather Starting	1-4
General Information.....	1-4
Using Starting Aids.....	1-5
Electromagnetic Interference (EMI)	1-8
General Information.....	1-8
System EMI Radiation Levels.....	1-8
System EMI Susceptibility.....	1-8
Engine Operating Range	1-8
General Information.....	1-8
Engine Shutdown	1-8
General Information.....	1-8
Normal Starting Procedure	1-2
General Information.....	1-2
Jump Starting.....	1-4
Operating Instructions - Overview	1-1
General Information.....	1-1
Operating the Engine	1-5
Ambient Temperature.....	1-6
0 to -32°C [32 to -25°F].....	1-6
-32 to -54°C [-25 to -65°F].....	1-6
Cold Weather.....	1-6
Normal.....	1-5
Winterfronts and Shutters.....	1-7
Starting Procedure After Extended Shutdown or Oil Change	1-5
General Information.....	1-5

This Page Left Intentionally Blank

Operating Instructions - Overview

General Information



Correct care of your engine will result in longer life, better performance, and more economical operation.

Follow the daily maintenance checks listed in Maintenance Guidelines (Section 2).

The new Cummins engine associated with this manual does **not** require a "break-in" procedure. This section of the manual provides all of the necessary information required for proper engine operation.

Check the oil pressure indicators, temperature indicators, warning lights, and other gauges daily to make sure they are operational.

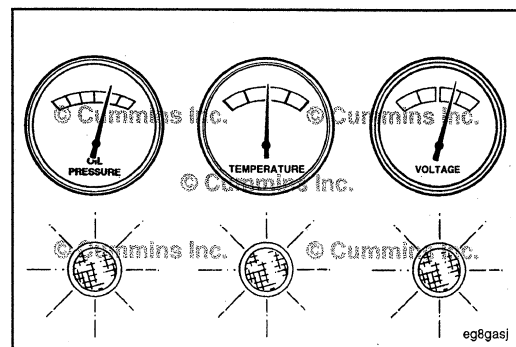

⚠ WARNING ⚠

DO NOT OPERATE A DIESEL ENGINE WHERE THERE ARE OR CAN BE COMBUSTIBLE VAPORS. The vapors can be sucked through the air intake system and cause engine acceleration and overspeeding that can result in a fire, an explosion, and extensive property damage. Numerous safety devices are available, such as air intake shutoff devices, to minimize the risk of overspeeding where an engine, due to its application, due to a fuel spill or gas leak. Remember, Cummins has no way of knowing the use you have for your engine. **THE EQUIPMENT OWNER AND OPERATOR ARE RESPONSIBLE FOR SAFE OPERATION IN A HOSTILE ENVIRONMENT. CONSULT YOUR CUMMINS AUTHORIZED REPAIR LOCATION FOR FURTHER INFORMATION.**

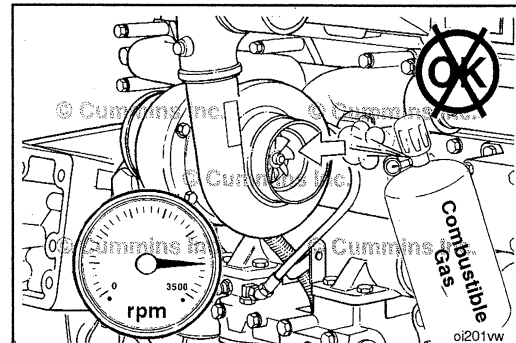

Cummins recommends the installation of an air intake shutoff device or a similar safety device to minimize the risk of overspeeding where an engine, due to the vehicle, vessel or equipment being operated in a combustible environment, such as due to a fuel spill or gas leak.

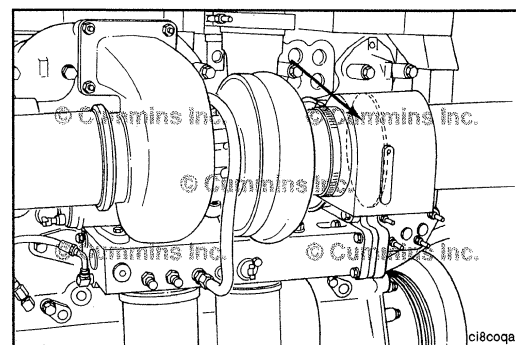

⚠CAUTION⚠

Do not expose the engine to corrosive chemicals. Corrosive chemicals can damage the engine.

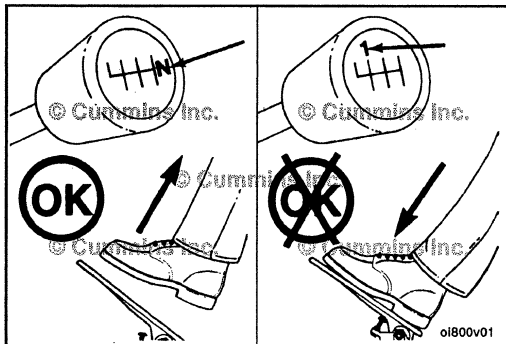

Normal Starting Procedure
General Information

⚠WARNING⚠

Do not depress the accelerator pedal or move the accelerator lever from the idle position while cranking the engine. This can result in engine overspeed and severe damage to the engine.

⚠CAUTION⚠

To prevent damage to the starting motor, do not engage the starting motor for more than 30 seconds. Wait 2 minutes between each attempt to start (electrical starting motors only).

NOTE: Engines equipped with air starting motors require a minimum of 480 kPa [70 PSI].

- Disengage the driven unit, or if equipped, put the transmission in neutral.
- With the accelerator pedal or lever in the idle position, turn the key switch to the ON position, and wait for the WAIT-TO-START lamp to go out; then, turn the key to the START position.
- If the engine does **not** start after three attempts, check the fuel supply system. Absence of blue or white exhaust smoke during cranking indicates no fuel is being delivered.

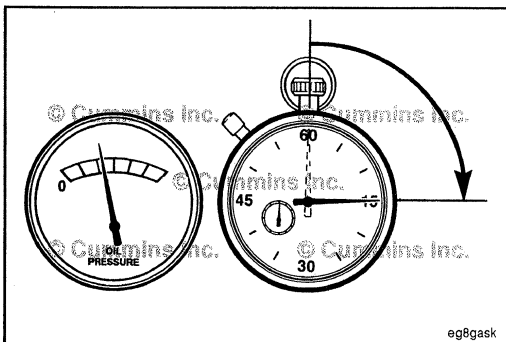

⚠CAUTION⚠

The engine must have adequate oil pressure within 15 seconds after starting. If the WARNING lamp indicating low oil pressure has not gone out or there is no oil pressure indicated on a gauge within 15 seconds, shut off the engine immediately to avoid engine damage. The low oil pressure troubleshooting procedure is located in Troubleshooting Symptoms (Section TS).

QSB Series
Section 1 - Operating Instructions

Idle the engine 3 to 5 minutes before operating with a load.

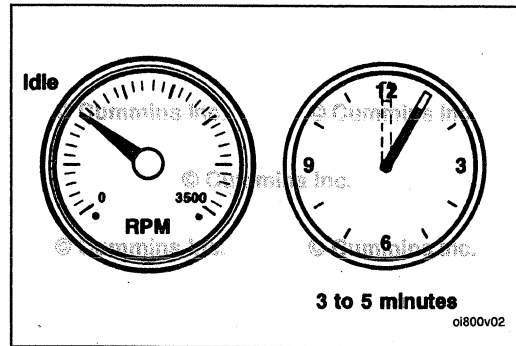

After starting a cold engine, increase the engine speed (rpm) slowly to provide adequate lubrication to the bearings and to allow the oil pressure to stabilize.

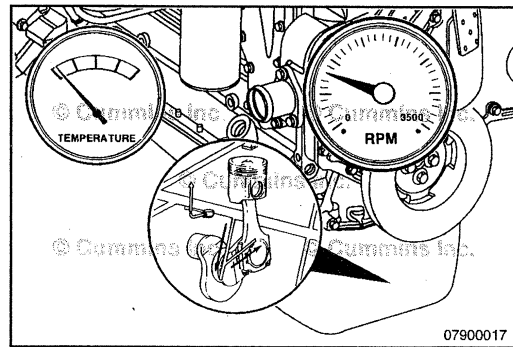

⚠CAUTION⚠

Do not operate engine at low idle for long periods with engine coolant temperature below the minimum specification in Maintenance Specifications (Section V). This can result in the following:

- Fuel Dilution of the lubricating oil
- Carbon build up in the cylinder
- Cylinder head valve sticking
- Reduced performance

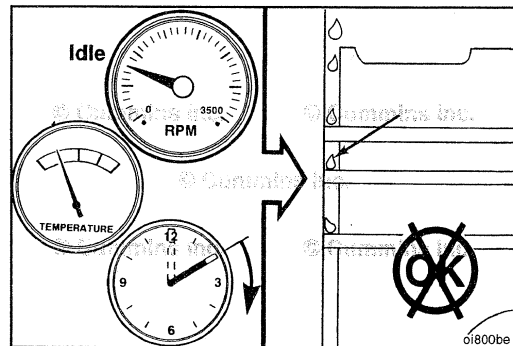

Jump Starting

⚠ WARNING ⚠

Batteries can emit explosive gases. To avoid personal injury, always ventilate the compartment before servicing the batteries. To avoid arcing, remove the negative (-) battery cable first and attach the negative (-) battery cable last.

⚠ CAUTION ⚠

When using jumper cables to start the engine, make sure to connect the cables in parallel: Positive (+) to positive (+) and negative (-) to negative (-). When using an external electrical source to start the engine, turn the disconnect switch to the OFF position. Remove the key before attaching the jumper cables.

⚠ CAUTION ⚠

To avoid damage to engine parts, do not connect jumper starting or battery charging cable to any fuel system or electronic component.

The accompanying illustration shows a typical parallel battery connection. This arrangement doubles the cranking amperage.

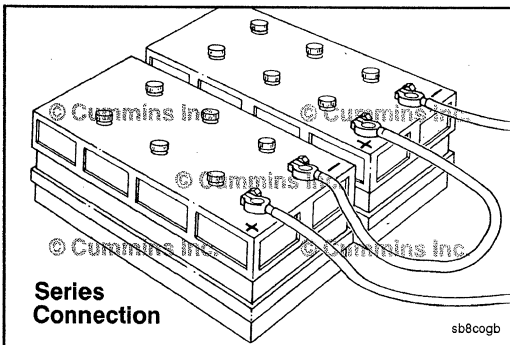
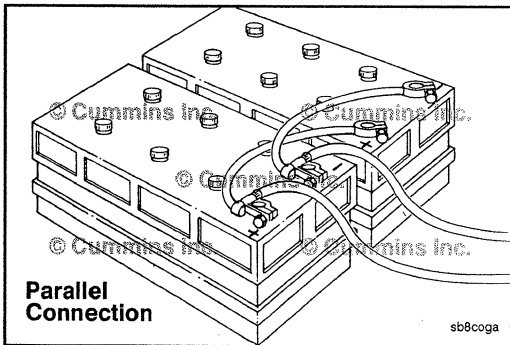

This illustration shows a typical series battery connection. This arrangement, positive (+) to negative (-), doubles the voltage.

Using Starting Aids

Cold weather starting aids are available for your engine. Contact a local Cummins Authorized Repair Location for more information.

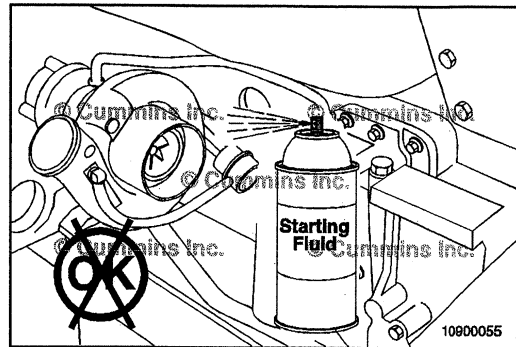

Starting Procedure After Extended Shutdown or Oil Change

General Information

Follow the Normal Starting Procedure in this section. The engine will not start until the minimum cranking oil pressure is detected by the ECM. It can take more cranking time to start the engine after an extended shut down or oil change.

Operating the Engine

Normal

If equipped, monitor the oil pressure and coolant temperature gauges frequently. Refer to Lubricating Oil System specifications and Cooling System specifications, in Maintenance Specifications (Section V) for recommended operating pressures and temperatures. Shut off the engine if any pressure or temperature does **not** meet the specifications.

Continuous operation with engine coolant temperature above or below the engine coolant temperature specifications listed in Maintenance Specifications (Section V) can damage the engine.

If an overheating condition starts to occur, reduce the power output of the engine by releasing the accelerator pedal or lever or shifting the transmission to a lower gear, or both, until the temperature returns to the normal operating range. If the engine temperature does **not** return to normal, shut off the engine, and refer to Troubleshooting Symptoms (Section TS), or contact a Cummins Authorized Repair Location.

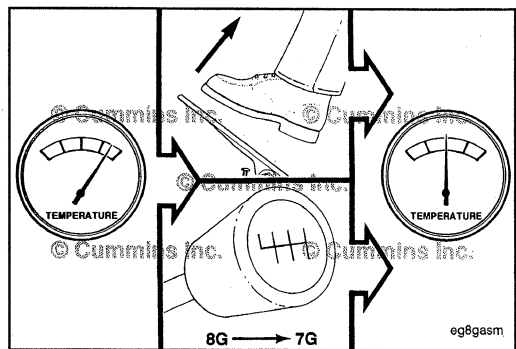
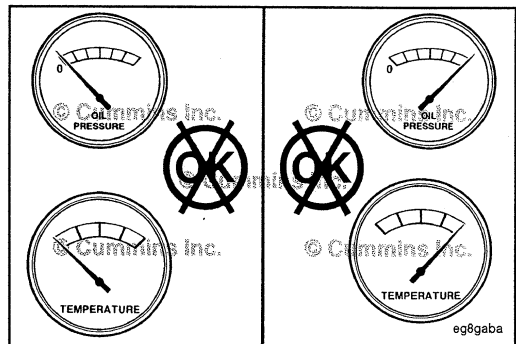

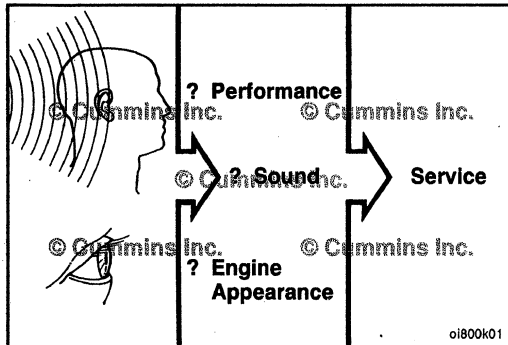

Most failures give an early warning. Look and listen for changes in performance, sound, or engine appearance that can indicate service or engine repair is needed. Some changes to look for are:

- Engine misfires
- Vibration
- Unusual engine noises
- Sudden changes in engine operating temperatures or pressures
- Excessive smoke
- Loss of power
- An increase in oil consumption
- An increase in fuel consumption
- Fuel, oil, or coolant leaks.

Cold Weather

It is possible to operate engines in extremely cold environments if they are properly prepared and maintained. Satisfactory performance of an engine in low ambient temperature conditions requires modification of the engine, surrounding equipment, operating practices and maintenance procedures.

The correct engine coolant lubricating oil and fuels **must** be used for the cold weather range in which the engine is being operated. Below are the recommendations for these critical engine fluids:

Ambient Temperature

0 to -32°C [32 to -25°F]

Use 50-percent ethylene glycol antifreeze and 50-percent water for the engine coolant mixture.

Refer to Maintenance Specifications (Section V) Lubricating Oil recommendations for the correct specifications.

The Diesel fuel must have maximum cloud and pour points 6°C [10°F] lower than the ambient temperature in which the engine operates.

-32 to -54°C [-25 to -65°F]

Use 60-percent ethylene glycol antifreeze and 40-percent water for the engine coolant mixture.

Refer to Maintenance Specifications (Section V) Lubricating Oil recommendations for the correct specifications.

The Diesel fuel must have maximum cloud and pour points 6°C [10°F] lower than the ambient temperature in which the engine operates.

The following cold weather operating aids are required for cold weather situations:

Cold Weather Operating Aids										
Temperature	Starting Aid	Coolant Heater	Oil Heater	Under-hood Air	Fuel Heater	Battery Heater	Radiator Shutters	Engine Enclosure	Winter Front	Thermostatic Fan
50 to 32° F 10 to 0° C										
32 to -10° F 0 to -23° C	↑	↑	↑	↑	↑	↑	↑	↑	↑	↑
-10 to -25° F -23 to -32° C	↑ Required	↑ Required	↑ Required	↑ Required	↑ Required	↑ Required	↑ Required	↑ Required	↑ Required	↑ Required
-25 to -65° F -32 to -54° C	↑ Required	↑ Required	↑ Required	↑ Required	↑ Required	↑ Required	↑ Required	↑ Required	↑ Required	↑ Required

* Required dependent upon viscosity/pour point.

© Cummins Inc.

oi202vj

Winterfronts and Shutters

Winterfronts and shutters can be used on a vehicle or equipment to reduce air flow through the radiator core into the engine compartment. This can reduce the time required to warm the engine and help maintain the engine coolant temperature. The engine coolant temperature specifications are in the Maintenance Specification (Section V).

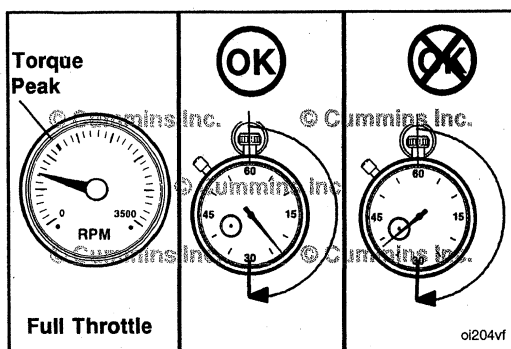

Engine Operating Range General Information

⚠CAUTION⚠

Do not operate the engine at full throttle operation below peak torque rpm (refer to engine dataplate for peak torque rpm) for more than 30 seconds. Operating the engine at full throttle below peak torque will shorten engine life to overhaul, can cause serious engine damage, and is considered engine abuse.

Cummins® engines are designed to operate successfully at full throttle under transient conditions down to peak torque engine speed. This is consistent with recommended operating practices.

⚠CAUTION⚠

Do not operate the engine beyond the maximum engine speed. Operating the engine beyond the maximum engine speed can cause severe engine damage. Use proper operating techniques for the vehicle, vessel, or equipment to prevent engine overspeed. The maximum engine speed specification is listed in Maintenance Specifications (Section V).

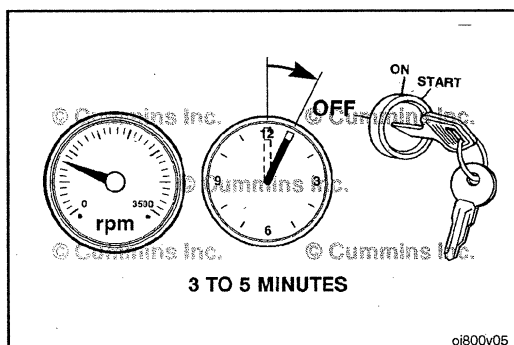

Engine Shutdown General Information

Allow the engine to idle 3 to 5 minutes before shutting it off after a full-load operation. This allows adequate cool down of pistons, cylinders, bearings, and turbocharger components.

Turn the ignition switch to the OFF position. If the engine does not shut down, refer to Troubleshooting Symptom (Section TS).

Electromagnetic Interference (EMI)

General Information

Some engine applications utilize accessories (CB radios, mobile transmitters, etc.) that generate and use radio frequency energy that, if **not** installed and used properly, can cause electromagnetic interference (EMI) conditions to exist between the accessory and Cummins electronic controlled fuel system. Cummins is **not** liable for any performance problems with either the fuel system or the accessory due to EMI. EMI is **not** considered by Cummins to be an engine failure and therefore is **not** warrantable.

System EMI Susceptibility

Your Cummins product has been designed and tested for minimum sensitivity to incoming electromagnetic energy. Testing has shown that there is no engine performance degradation at relatively high energy levels; however, if very high energy levels are encountered, then some noncritical diagnostic fault code logging can occur. The fuel system EMI susceptibility level will protect your engine from most, if **not** all, electromagnetic energy-emitting devices that meet the Federal Communications Commission legal requirements.

System EMI Radiation Levels

Your Cummins product has been designed to emit minimum electromagnetic energy. Electronic components are required to pass various Cummins and industry EMI specifications. Testing has shown that when the engine is properly

installed, it will not interfere with onboard communication equipment or with the vehicle's, equipment's, or vessel's ability to meet any applicable EMI standards and regulated specifications.

If an interference condition is observed, follow the suggestions below to reduce the amount of interference:

1. Locate the receiving antenna as far away from the engine and as high as possible.
2. Locate the receiving antenna as far away as possible from all metal obstructions (e.g., exhaust stacks)
3. Consult a representative of the accessory supplier in your area to:
 - Calibrate accurately the device for proper frequency, power output, and sensitivity (both base and remote site devices **must** be properly calibrated)
 - Obtain antenna reflective energy data measurements to determine the optimum antenna location
 - Obtain optimum antenna type and mounting arrangement for your application
 - Make sure your accessory equipment model is built for maximum filtering to reject incoming electromagnetic noise.

Section 2 - Maintenance Guidelines

Section Contents

	Page
Maintenance Guidelines - Overview	2-1
General Information.....	2-1
Maintenance Record Form	2-4
Maintenance Data.....	2-4
Maintenance Schedule	2-3
General Information.....	2-3
Oil Drain Intervals.....	2-3
Tool Requirements	2-2
General Information.....	2-2

This Page Left Intentionally Blank

Maintenance Guidelines - Overview

General Information

Cummins Inc. recommends that the engine be maintained according to the Maintenance Schedule in this section.

If the engine is operating in ambient temperatures below -18°C [0°F] or above 38°C [100°F], perform maintenance at shorter intervals. Shorter maintenance intervals are also required if the engine is operated in a dusty environment or if frequent stops are made. Contact your local Cummins Authorized Repair Location for recommended maintenance intervals.

Some of these maintenance procedures require special tools or must be completed by qualified personnel. Contact your local Cummins Authorized Repair Location for detailed information.

If your engine is equipped with a component or accessory not manufactured by Cummins Inc., refer to the component manufacturer's maintenance recommendations.

Use the chart provided in this section as a convenient way to record maintenance performed.

Tool Requirements

General Information

Most of the maintenance operations described in this manual can be performed with common hand tools (metric and S.A.E. wrenches, sockets, and screwdrivers).

The following is a list of special service tools required for some maintenance operations:

Tool Part Number	Description	Used for
ST-1273	Pressure gauge	Measure Intake Manifold Pressure
3400158	Filter Wrench	Oil and Fuel Filters
3824591	Barring tool	Rotate the engine
CC-2800	Refractometer	Check antifreeze concentration and battery specific gravity
3164488	Digital Multimeter	Measure Voltage on electrical equipment
3822525	Belt Tensioner Gauge (click type)	Check belt tension (6 to 12 v-ribbed belts)
3164795	Torque Wrench	Dial type 3/8 drive 0-250 in-lb
3164794	Torque Wrench	Micro-adjust 3/8 drive 10-100 ft-lb
3164797	Torque Wrench	Micro-adjust 1/2 drive 50-250 ft-lb

Contact your nearest Cummins Authorized Repair Location for the required service tools.

Maintenance Schedule

General Information

For your convenience, listed below are the section numbers that contain specific instructions for performing the maintenance checks.

Perform maintenance at whichever interval that occurs first. At each scheduled maintenance interval, perform all previous maintenance checks that are due for scheduled maintenance.

Daily or Refueling - Maintenance Check³Section 3

- Air Tank and Reservoirs - Drain
- Crankcase Breather Tube - Inspect
- Engine Coolant Level - Check/Correct
- Fuel-Water Separator - Drain

Every 250 Hours or 3 Months - Maintenance Check³Section 4

- Air Cleaner Restriction - Check/Correct
- Air Compressor Mounting Hardware - Check/Correct
- Charge Air Cooler - Check/Correct
- Charge Air Piping - Check/Correct
- Radiator Hoses - Check
- Air Intake Piping — Inspect
- Cooling Fan — Check
- Coolant Level — Check/Correct
- Drive Belts — Check/Correct

Every 500 Hours or 6 Months - Maintenance Check^{1, 2, 3}Section 5

- Engine Coolant - Antifreeze Check
- Fuel Filter, Spin-on-Type - Replace
- Lubricating Oil and Filters - Change

Every 1000 Hours or 1 Year - Maintenance Check³Section 6

- Cooling Fan Belt Tensioner - Check/Correct
- Fan Hub, Belt-Driven - Check/Correct

Every 2000 Hours, or 2 Years - Maintenance Check^{2, 3}Section 7

- Air Compressor Discharge Line - Check/Correct
- Cooling System - Drain, Flush, and Fill
- Vibration Damper, Rubber - Check
- Vibration Damper, Viscous - Check

Every 5000 Hours or 4 Years - Maintenance Check³Section 8

- Overhead Set - Adjust

1. The lubricating oil and lubricating oil filter interval can be adjusted based on application, fuel consumption, gross vehicle weight, and idle time. See the Oil Drain Intervals in this section.
2. Antifreeze check interval is every oil change or 500 hours or 6 months, whichever occurs first. The operator **must** use a heavy-duty year-round antifreeze that meets the chemical composition of GM6038M. The antifreeze change interval is 2 years or 2000 hours whichever occurs first. Antifreeze is essential for freeze, overheat, and corrosion protection.
3. Follow the manufacturer's recommended maintenance procedures for the starter, alternator, generator, batteries, electrical components, exhaust brake, charge air cooler, radiator, air compressor, air cleaner, freon compressor, and fan clutch. Refer to Procedure 203-001 (Component Manufacturers) in Section M.

Oil Drain Intervals

Refer to table 1 to determine the maximum recommended oil change and filter change interval in hours or months, whichever comes first.

American Petroleum Institute Classification (API)	European Classification (ACEA)	Engine Rating is 261Hp [195kW] or greater	Engine Rating is 260Hp [194W] or less
API CH-4/SJ	ACEA E-5	250 hours or 3 months	500 hours or 6 months
API CF-4/SG	ACEA E-3 and ACEA E-2	125 hours or 6 weeks	250 hours or 3 months
API CD API CE API CG-4/SH	ACEA E-1	Obsolete. Do not Use	Obsolete. Do Not Use

Section 3 - Maintenance Procedures at Daily Interval

Section Contents

	Page
Air Tanks and Reservoirs	3-2
Drain.....	3-2
Crankcase Breather Tube	3-2
Maintenance Check.....	3-2
Daily Maintenance Procedures - Overview	3-1
Engine Operation Report.....	3-1
General Information.....	3-1
Unusual Engine Noise.....	3-1
Drive Belts	3-3
Maintenance Check.....	3-3
Poly-Vee Belt.....	3-3
Cogged Belt.....	3-4
Fuel-Water Separator	3-2
Drain.....	3-2
Canister Type.....	3-2
Spin-on Type.....	3-3
Lubricating Oil Level	3-3
Maintenance Check.....	3-3

This Page Left Intentionally Blank

Daily Maintenance Procedures - Overview

General Information

Preventative maintenance begins with day-to-day awareness of the engine and its system. Before starting the engine, check the oil and coolant levels. Look for:

- Leaks
- Loose or damaged parts
- Worn or damaged belts
- Any change in engine appearance.
- Odor of fuel

Engine Operation Report

The engine **must** be maintained in top mechanical condition if the operator is to get optimum satisfaction from its use. The maintenance department needs daily running reports from the operator to make necessary adjustments in the time allocated. The daily running report also helps to make provisions for more extensive maintenance work as the reports indicate the necessity.

Comparison and intelligent interpretation of the daily report, along with a practical follow-up action, will eliminate most failures and emergency repairs.

Report to the maintenance department any of the following conditions:

- Low lubricating oil pressure
- Low power
- Power increases or engine surge
- Erratic or no accelerator control or response
- Any warning lights flashing or staying on
- Abnormal water or oil temperature
- Unusual engine noise
- Excessive smoke
- Excessive use of coolant, fuel, or lubricating oil
- Any fuel, coolant, or lubricating oil leaks
- Loose or damaged parts
- Worn or damaged belts

Unusual Engine Noise

During daily maintenance checks, listen for any unusual engine noise that can indicate that service is required.

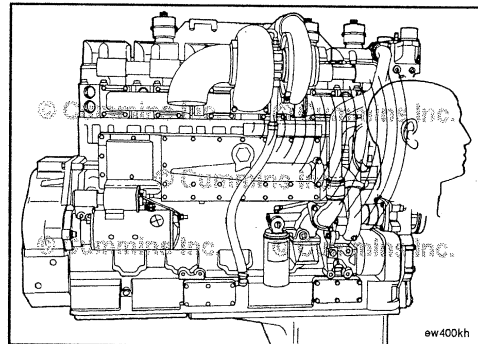

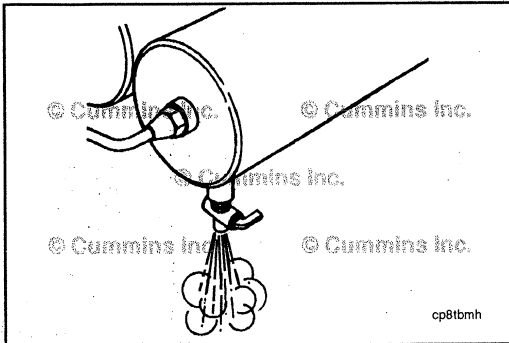

Air Tanks and Reservoirs Drain

If automatic purging or spitter valves are used, confirm the valves are operating correctly. If a manual drain valve is used on the wet tank, open the draincock on the wet tank to drain any moisture accumulated in the air system. If oil is present, the air compressor system **must** be checked. Contact your Cummins Authorized Repair Location.

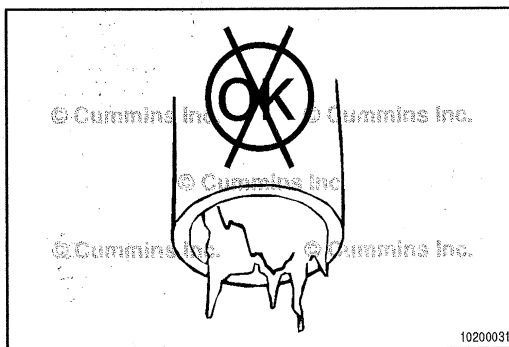

Crankcase Breather Tube Maintenance Check

Inspect the breather tube for sludge, debris, or ice in the tube.

Inspect the tube more frequently in icy conditions.

Fuel-Water Separator Drain



Drain the water-fuel separator into a container and dispose of in accordance with local environmental regulations.

Cummins Inc. requires a fuel-water separator or fuel filter be installed in the fuel supply system.

Drain the water and sediment from the separator daily.

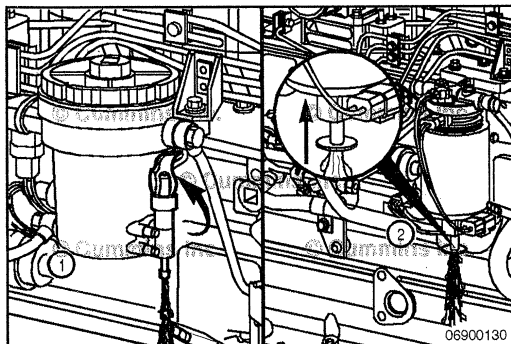

Canister Type

Shut off the engine.

Pull up on the drain valve lever until fluid drains out of the drain tube. Drain the filter sump until clear fuel is visible.

Push up on the drain valve until fluid drains out of the drain tube.

Spin-on Type

Shut off the engine.

Use your hand to open the drain valve. Turn the valve **counterclockwise** approximately 3½ turns until the valve drops down 25.4mm [1 in] and draining occurs.

Drain the filter sump until clear fuel is visible.



When closing the drain valve, do not overtighten the valve. Overtightening can damage the threads.

To close the valve, lift the valve and turn **clockwise** until it is hand-tight.

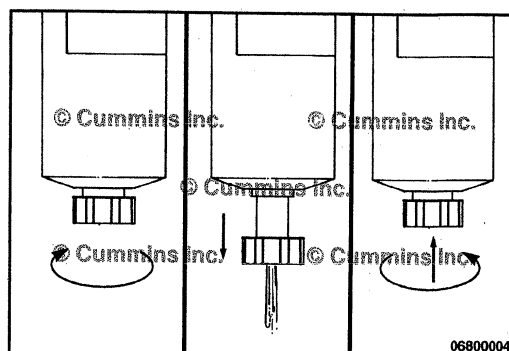

0680004

Lubricating Oil Level Maintenance Check



Never operate the engine with oil level below the L (low) mark or above the H (high) mark. Poor engine performance or engine damage can occur.

The engine **must** be level when checking the oil level to make sure the measurement is correct.

Shut off the engine for an accurate reading.

Wait at least 15 minutes after shutting off the engine to check the oil level. This allows time for the oil to drain into the oil pan.

For additional lubricating oil recommendations and oil pan capacity information, refer to Maintenance Specifications (Section V).

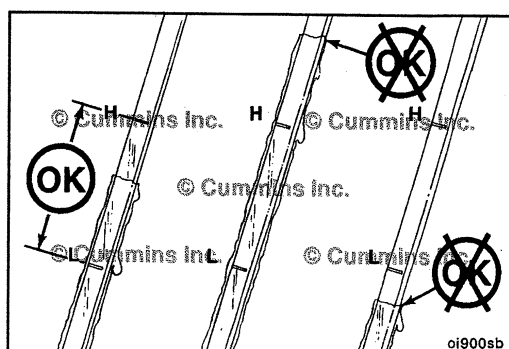

0i900sb

Drive Belts Maintenance Check

Poly-Vee Belt

Inspect the belts daily. Check the belt for intersecting cracks. Traverse (across the belt width) cracks are acceptable. Longitudinal (direction of belt length) cracks that intersect with transverse cracks are **not** acceptable. Replace the belt if it is frayed or has pieces of material missing. Refer to Section A for belt adjustment and replacement procedures.

Belt damage can be caused by:

- Incorrect tension
- Incorrect size or length
- Pulley misalignment
- Incorrect installation
- Severe operating environment
- Oil or grease on the side of belts.

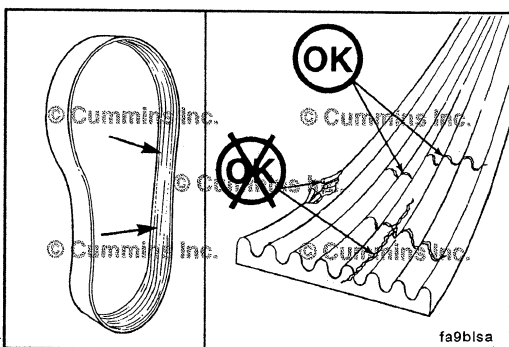

fa9b1sa

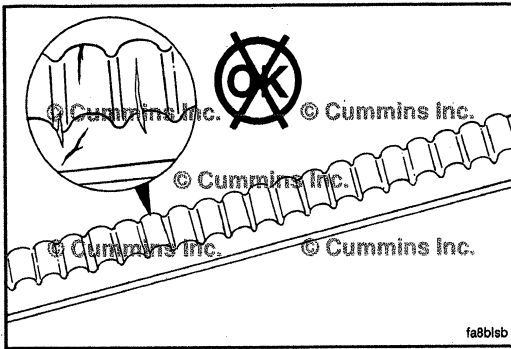

Cogged Belt

Inspect the belts daily. Replace the belts if they are cracked, frayed, or have chunks of material missing. Small cracks are acceptable.

Adjust the belts that have a glazed or shiny surface, which indicates belt slippage. Correctly installed and tensioned belts will show even pulley and belt wear. Refer to Section A for belt adjustment and replacement procedures.

Belt damage can be caused by:

- Incorrect tension
- Incorrect size or length
- Pulley misalignment
- Incorrect installation
- Severe operating environment
- Oil or grease on the belts

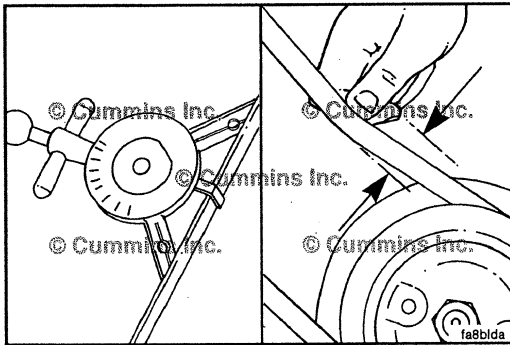

Measure the belt tension in the center span of the pulleys.

Refer to the Belt Tension Chart in Section V for the correct gauge and tension value for the belt width used.



An alternate method (deflection method) can be used to check belt tension by applying 110 N [25 lbf] force between the pulleys on v-belts. If the deflection is more than one belt thickness per foot of pulley center distance, the belt tension **must** be adjusted.

Refer to Section A for adjustment procedures.

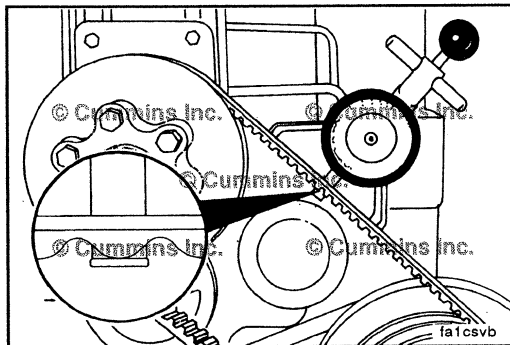

For cogged belts, **make sure** that the belt tension gauge is positioned so that the center tensioning leg is placed directly over the high point (hump) of a cog. Other positioning will result in incorrect measurement.

Section 4 - Maintenance Procedures at 250 hours or 3 months

Section Contents

	Page
Air Cleaner Restriction	4-1
Maintenance Check.....	4-1
Air Compressor	4-2
Maintenance Check.....	4-2
Air Intake Piping	4-3
Maintenance Check.....	4-3
Charge-Air Cooler	4-2
Maintenance Check.....	4-2
Charge-Air Piping	4-2
Maintenance Check.....	4-2
Coolant Level	4-4
Maintenance Check.....	4-4
Fan, Cooling	4-3
Inspect for Reuse.....	4-3
Maintenance Procedures - Overview	4-1
General Information.....	4-1
Radiator Hoses	4-3
Maintenance Check.....	4-3

This Page Left Intentionally Blank

Maintenance Procedures - Overview

General Information

All maintenance checks and inspections listed in previous maintenance intervals **must** also be performed at this time, in addition to those listed under this maintenance interval.

Air Cleaner Restriction

Maintenance Check

Mechanical Indicator

NOTE: Do **not** remove the felt washer from the indicator. The felt washer absorbs moisture.

A mechanical restriction indicator is available to indicate excessive air restriction through a dry-type air cleaner. This instrument can be mounted in the air cleaner outlet or on the instrument panel. The red flag (1) in the window gradually rises as the cartridge loads with dirt. After changing or replacing the cartridge, reset the indicator by pushing the reset button (2).

Restriction or vacuum indicators need to be installed as close as possible to the turbocharger air inlet in order to obtain a true indication of restrictions.

⚠CAUTION⚠

Never operate the engine without an air cleaner. Intake air must be filtered to prevent dirt and debris from entering the engine and causing premature wear.

Vacuum Indicator

Vacuum switches actuate a warning light on the instrument panel when the air restriction becomes excessive.

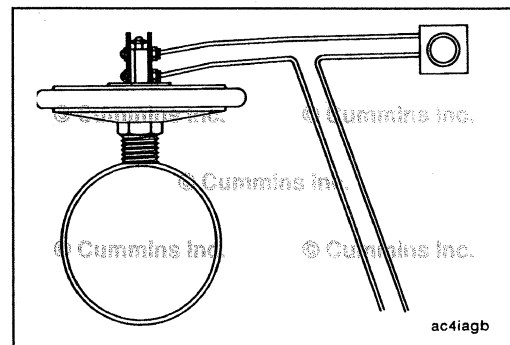
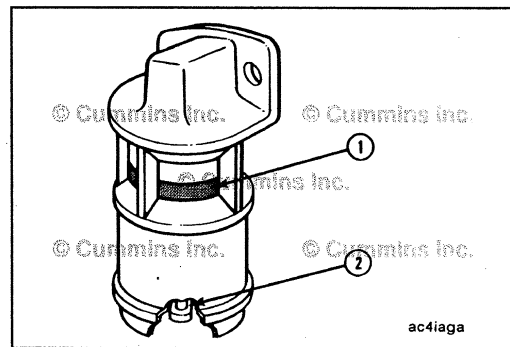

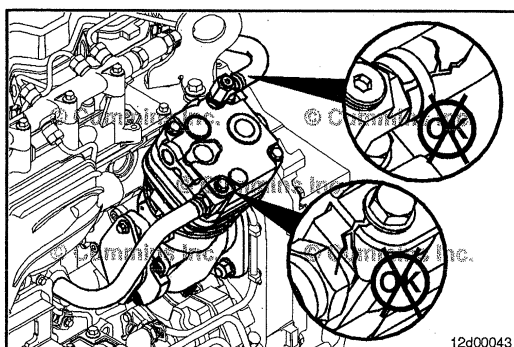

Air Compressor Maintenance Check



NOTE: Depending on application, it is possible engines will **not** be equipped with an air compressor.

Inspect compressor housing for cracks and damage.

Inspect hydraulic pump couplings for cracks, wear, or damage (if equipped).

Inspect air plumbing for splits or cracks.

Inspect the air compressor mounting nuts, including support bracket, for loose or damaged hardware.

Operate the engine and check for correct compressor operation and air, oil, and coolant leaks.

Torque Value:

Mounting	18	77 N•m	[57 ft-lb]
mm			

Torque Value:

Bracket 10 mm	45 N•m	[33 ft-lb]
---------------	--------	--------------

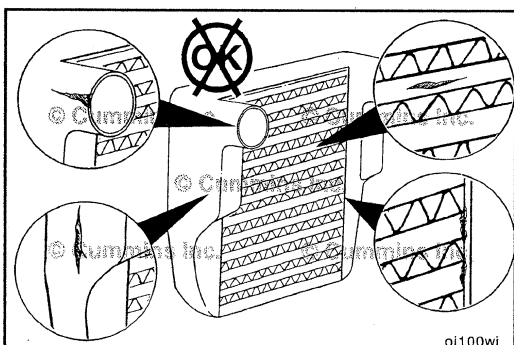

Charge-Air Cooler Maintenance Check



Inspect the charge-air cooler (CAC) for dirt and debris blocking the fins. Check for cracks, holes, or other damage. If damage is found, refer to the vehicle, vessel, or equipment manufacturer.

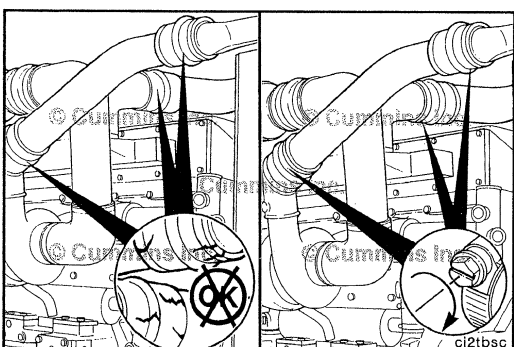

Charge-Air Piping Maintenance Check



Inspect the charge-air piping and hoses for leaks, holes, cracks, or loose connections. Tighten the hose clamps if necessary. Refer to the vehicle or equipment manufacturer's specifications for the correct torque value.

Radiator Hoses Maintenance Check



Check all hoses for cracks, cuts, or collapsing.

NOTE: The silicone engine coolant hose will exhibit swelling due to the elasticity of the hose.

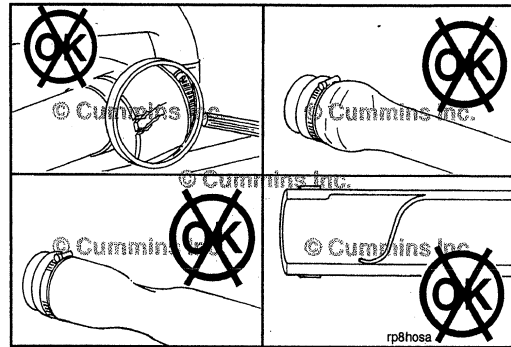

Air Intake Piping Maintenance Check



Visually inspect the intake piping daily for wear points and damage to piping, loose clamps, or punctures that can damage the engine.

Replace damaged pipes, and tighten loose clamps, as necessary, to prevent the air system from leaking.

Torque Value: 8 N•m [72 in-lb]

Check for corrosion under the clamps and hoses of the intake system piping. Corrosion can allow corrosive products and dirt to enter the intake system. Disassemble and clean, as required.

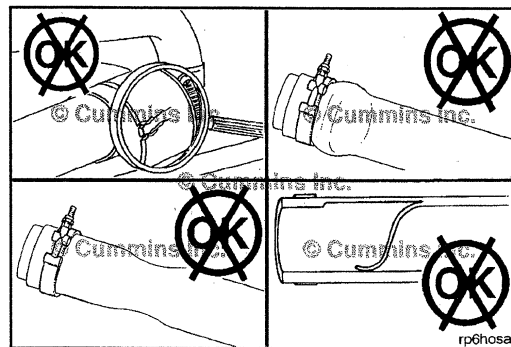

Fan, Cooling Inspect for Reuse

▲ WARNING ▲

Do not rotate the engine by pulling or prying on the fan. The fan blade(s) can be damaged and cause the fan to fail and cause personal injury or property damage. Use the accessory drive shaft or the crankshaft barring tool to rotate the crankshaft.

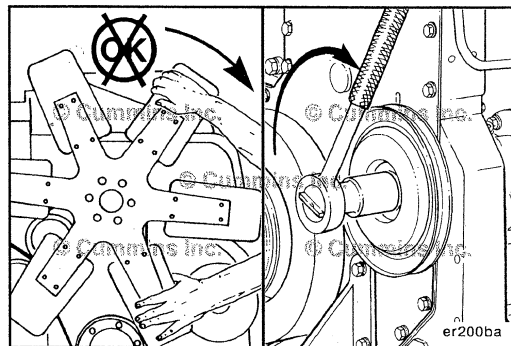

A visual inspection of the cooling fan is required daily. Check for cracks, loose rivets, and bent or loose blades. Check the fan to make sure it is securely mounted. Tighten the capscrews, if necessary.

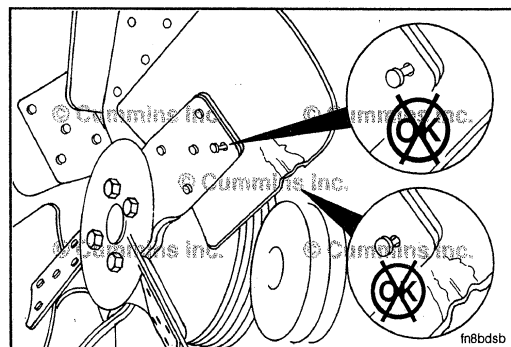

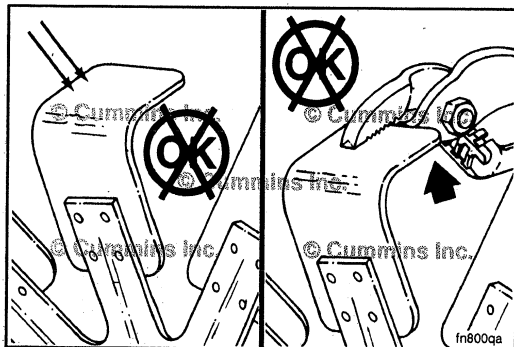

⚠ WARNING ⚠

Do not straighten a bent fan blade or continue to use a damaged fan. A bent or damaged fan blade can fail during operation and cause personal injury or property damage.

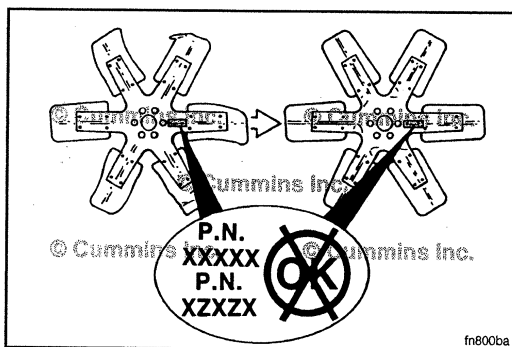

Replace original equipment fan that is damaged with a fan of the identical part number. Cummins Inc. **must** approve any other fan changes to be covered under warranty.

Refer to the vehicle or equipment manufacturer's specifications for capscrew torque.

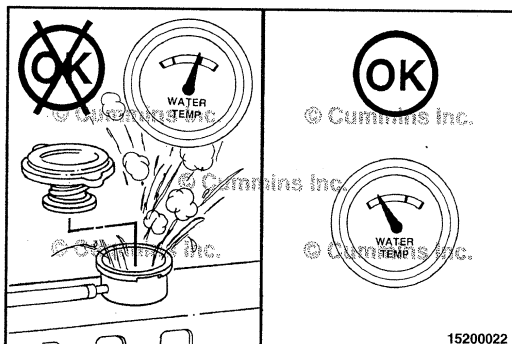

Coolant Level

Maintenance Check

⚠ WARNING ⚠

Do not remove a pressure cap from a hot engine. Wait until the coolant temperature is below 50°C [120°F] before removing the pressure cap. Heated coolant spray or steam can cause personal injury.

⚠ CAUTION ⚠

Never use a sealing additive to stop leaks in the cooling system. This can result in cooling system plugging and inadequate coolant flow, causing the engine to overheat.

The coolant level **must** be checked daily.

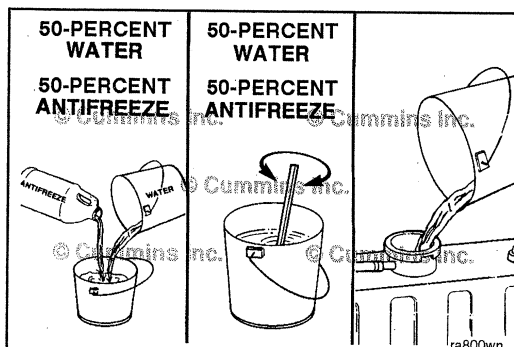

⚠ CAUTION ⚠

Do not add cold coolant to a hot engine. Engine castings can be damaged. Allow the engine to cool to below 50°C [120°F] before adding coolant.

Make up coolant added to the engine **must** be mixed with the correct proportions of antifreeze, supplemental coolant additive, and water to avoid engine damage.

Coolant recommendations and specification details on correct mixing of coolant can be found in Maintenance Specifications (Section V).

QSB Series
Section 4 - Maintenance Procedures at 250 hours or 3 months

Fill the cooling system with coolant to the bottom of the fill neck in the radiator fill or expansion tank.



NOTE: Some radiators have two fill necks, both of which **must** be filled when the cooling system is drained.

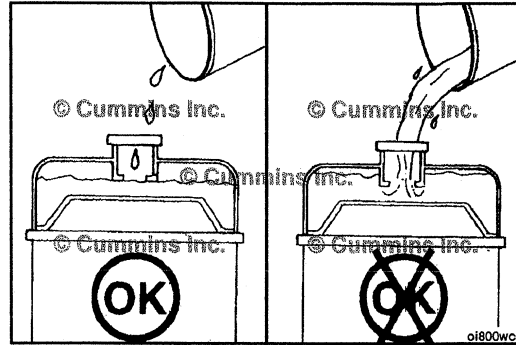

Section 5 - Maintenance Procedures at 500 hours or 6 months

Section Contents

	Page
Cooling System	5-1
Drain.....	5-2
Fill.....	5-5
Flush.....	5-3
General Information.....	5-1
Maintenance Check.....	5-2
Fuel Filter (Spin-On Type)	5-6
Install.....	5-6
Prime.....	5-7
Remove.....	5-6
Lubricating Oil and Filters	5-7
Drain.....	5-7
Fill.....	5-9
Install.....	5-8
Remove.....	5-8
Maintenance Procedures - Overview	5-1
General Information.....	5-1

This Page Left Intentionally Blank

Maintenance Procedures - Overview

General Information

All maintenance checks and inspections listed in previous maintenance intervals **must** also be performed at this time, in addition to those listed under this maintenance interval.

Cooling System

General Information

⚠ WARNING ⚠

Do not remove the pressure cap from a hot engine. Wait until the coolant temperature is below 50°C [120°F] before removing the pressure cap. Heated coolant spray or steam can cause personal injury.

NOTE: Never use a sealing additive to stop leaks in the coolant system. This can result in coolant system plugging and inadequate coolant flow, causing the engine to overheat.

The engine coolant level **must** be checked daily.

⚠ CAUTION ⚠

Do not add cold coolant to a hot engine. Engine castings can be damaged. Allow the engine to cool below 50°C [120°F] before adding coolant.

On applications that use a coolant recovery system, check to make sure the coolant is at the appropriate level on the coolant recovery tank, for the engine temperature.

Many coolant recovery/expansion tanks, also called "top tanks", have sight glasses (1) or are made of a clear material (not shown) to aid in checking the coolant level (2) without removing the radiator cap.

Fill the cooling system with coolant to the bottom of the fill neck in the radiator fill or recovery/expansion tank.

NOTE: Some radiators have two fill necks, both of which **must** be filled when the cooling system is drained.

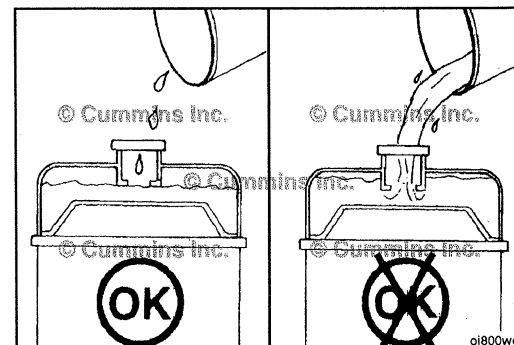
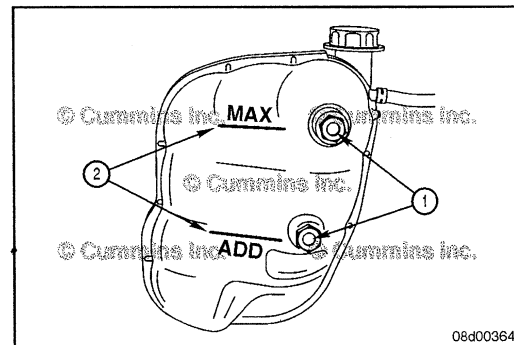
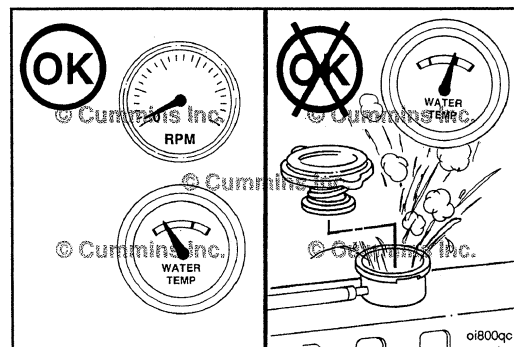

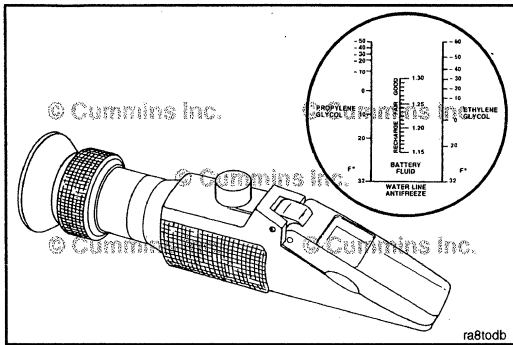

Maintenance Check

⚠ CAUTION ⚠

Overconcentration of antifreeze or use of high silicate antifreeze can cause damage to the engine.

Check the antifreeze concentration. Use a mixture of 50-percent water and 50-percent ethylene glycol or propylene glycol-base antifreeze to protect the engine to -32°C [-25°F] year-around.

The Fleetguard® refractometer, Part Number C2800, provides a reliable, easy to read, and accurate measurement of freezing point protection and glycol (antifreeze) concentration.

Antifreeze is essential in every climate as it broadens the operating temperature by lowering the coolant freezing point and by raising its boiling point.

The corrosion inhibitors also protect the cooling system components from corrosion and provides longer component life.

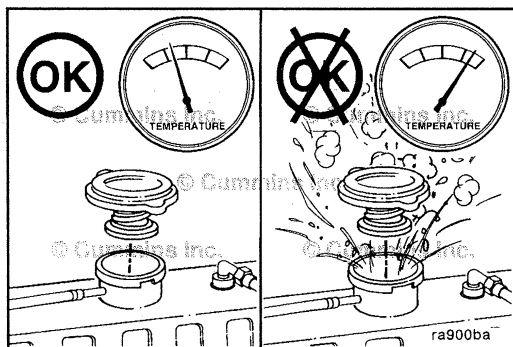

Drain

⚠ WARNING ⚠

Do not remove the pressure cap from a hot engine. Wait until the coolant temperature is below 50°C [122°F] before removing the pressure cap. Heated coolant spray or steam can cause personal injury.

Remove the radiator/expansion tank cap.

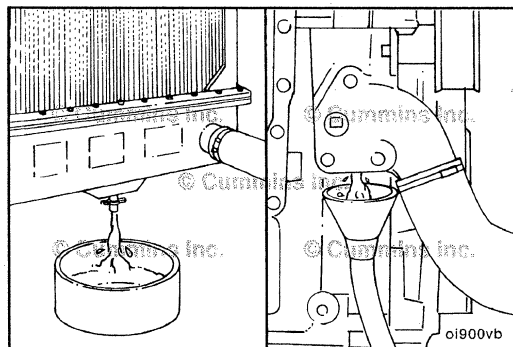

⚠ WARNING ⚠

Coolant is toxic. Keep away from children and pets. If not reused, dispose of in accordance with local environmental regulations.

Drain the cooling system by opening the drain valve on the radiator and removing the plug in the bottom of the water inlet. A drain pan with a capacity of 19 liters [5 gal.] will be adequate in most applications.

QSB Series
Section 5 - Maintenance Procedures at 500 hours or 6 months

Check for damaged hoses and loose or damaged hose clamps. Replace as required. Check the radiator for leaks, damage, and buildup of dirt. Clean and replace as required.

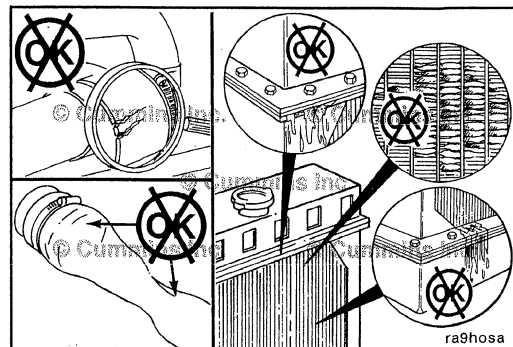
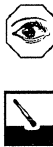

Flush

⚠CAUTION⚠

The system must be filled properly to prevent air locks. During filling, air must be vented from the engine coolant passages. Wait 2 to 3 minutes to allow air to be vented; then add mixture to bring the level to the top.

To be sure air is vented during the fill process:

- The thermostat has check balls that allow air to vent through the thermostat when the thermostat is closed.
- A deaeration port is located next to the water outlet connection which connects to the top tank/coolant recovery tank of the cooling system.

This provides adequate venting for a fill rate of 19 liters [5 gal.] per minute.

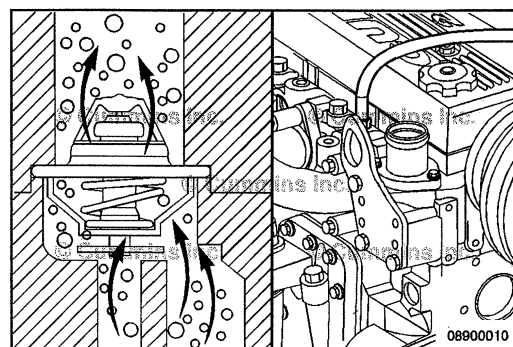

NOTE: An alternate to using sodium carbonate, as outlined in this procedure, is to use RESTORE™.

RESTORE™ is a heavy-duty cooling system cleaner that removes corrosion products, silica gel, and other deposits. The performance of RESTORE™ is dependent on time, temperature, and concentration levels. An extremely scaled or flow-restricted system, for example, can require higher concentrations of cleaners, higher temperatures, or longer cleaning times or the use of RESTORE Plus™. Up to twice the recommended concentration levels of RESTORE™ can be used safely. RESTORE Plus™ **must** be used **only** at its recommended concentration level. Extremely scaled or fouled systems can require more than one cleaning.



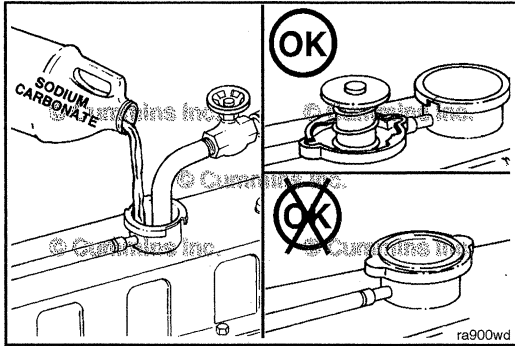

CAUTION

Do not install the radiator cap. The engine is to be operated without the cap for this process.

Fill the system with a mixture of sodium carbonate and water (or a commercially available equivalent).

NOTE: Adequate venting is provided for a fill rate of 19 liters [5 gal.] per minute.

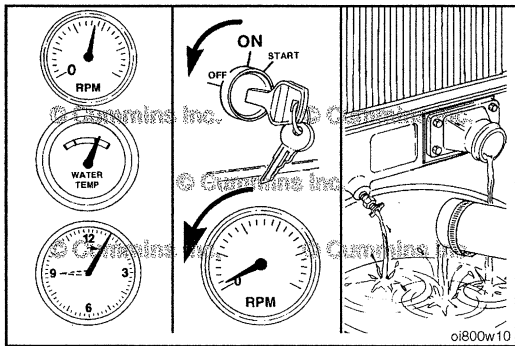

WARNING

Coolant is toxic. Keep away from children and pets. Dispose of in accordance with local environmental regulations.

Operate the engine for 5 minutes with the coolant temperature above 80°C [176°F].

Shut the engine off, and drain the cooling system.

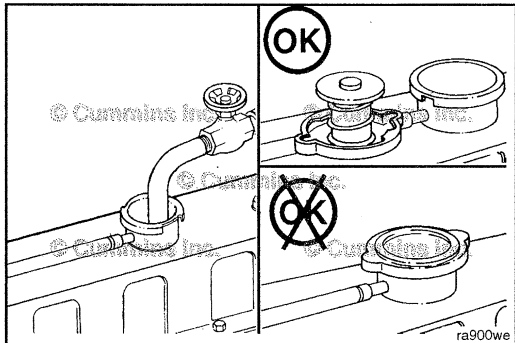

Fill the cooling system with clean water.

NOTE: Do not install the radiator cap.

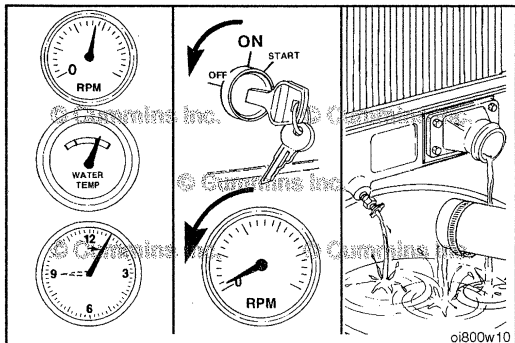

Operate the engine for 5 minutes with the coolant temperature above 80°C [176°F].

Shut the engine off, and drain the cooling system.

NOTE: If the water being drained is still dirty, the system must be flushed again until the water is clean.

Fill

⚠CAUTION⚠

The system must be filled properly to prevent air locks. During filling, air must be vented from the engine coolant passages. Wait 2 to 3 minutes to allow air to be vented; then add mixture to bring the level to the top.

To be sure air is vented during the fill process:

- The thermostat has check balls that allow air to vent through the thermostat when the thermostat is closed.
- A deaeration port is located next to the water outlet connection which connects to the top tank/coolant recovery tank of the cooling system.

The system has a design fill rate of 19 liters [5 gal.] per minute.

⚠CAUTION⚠

Never use water alone for coolant. Damage from corrosion can be the result of using water alone for coolant.

Use a mixture of 50-percent water and 50-percent ethylene glycol or propylene glycol antifreeze to fill the cooling system. For coolant recommendations and specifications, refer to Procedure 018-004 in Section V.

For cooling system capacity, refer to Procedure 018-018 (Cooling System) in Section V.

⚠WARNING⚠

Do not remove the pressure cap from a hot engine. Wait until the coolant temperature is below 50°C [122°F] before removing the pressure cap. Heated coolant spray or steam can cause personal injury.

Install the pressure cap. Operate the engine until it reaches a temperature of 80°C [180°F] and check for coolant leaks.

Check the coolant level again to make certain the system is full of coolant or that the coolant level has risen to the hot level in the recovery/expansion tank in the system, if so equipped.

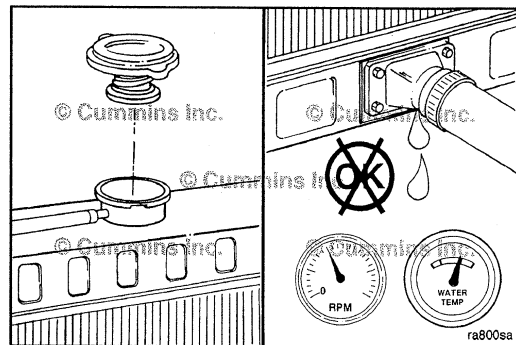
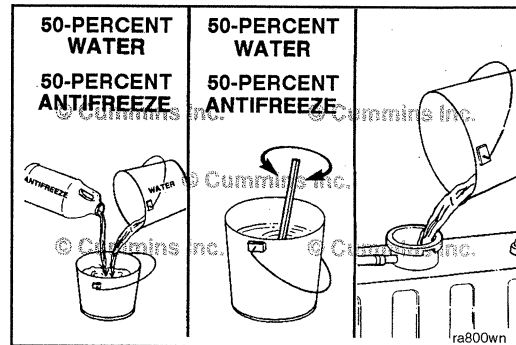
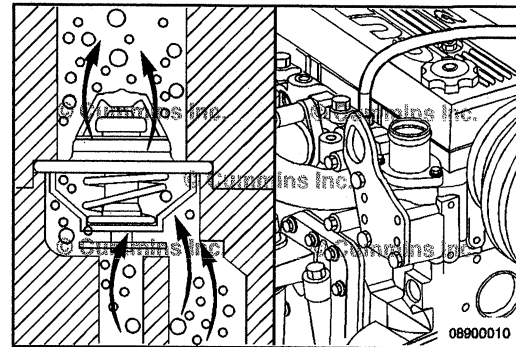

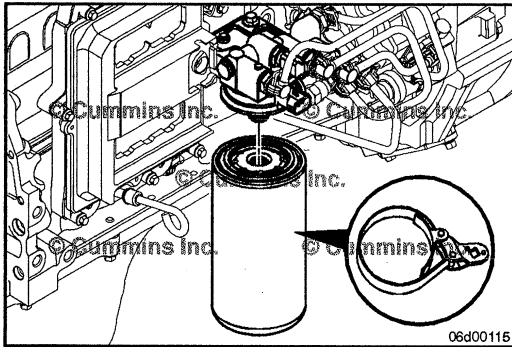

Fuel Filter (Spin-On Type)

Remove

Remove the spin-on fuel filter with fuel filter wrench, Part Number 3398231.

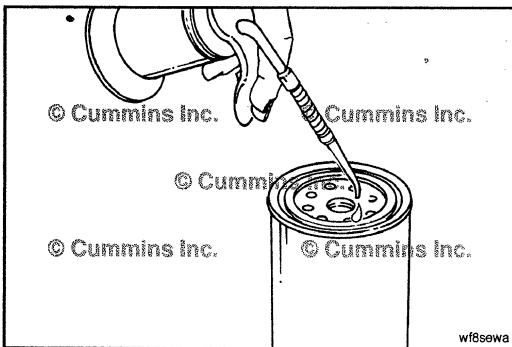

Install

NOTE: Do not pre-fill the on-engine fuel filter.

⚠CAUTION⚠

Do not pre-fill the on-engine fuel filter with fuel. The system must be primed after the fuel filter is installed. Pre-filling the fuel filter can result in debris entering the fuel system and damaging fuel system components.

Lubricate the o-ring seal with clean lubricating oil.

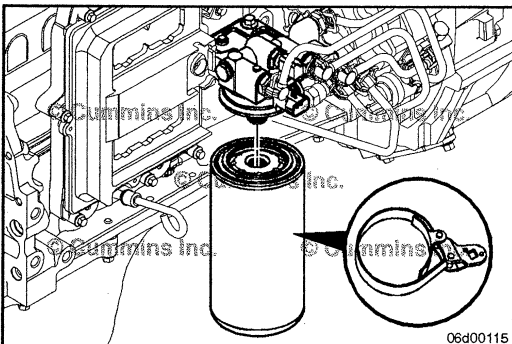

⚠CAUTION⚠

Mechanical overtightening will distort the threads, filter element seal, or filter can.

Use the correct fuel filter. See Cummins/Fleetguard®/Nelson filter specifications for the correct part number.

Install the filter on the filter head. Tighten the filter until the gasket contacts the filter head surface.

Tighten the fuel filter an additional 3/4 turn after contact or consult to filter manufacturers instructions as specified by the filter manufacturer.

Torque Value: 34 N•m [25 ft-lb]

Prime fuel system after fuel filter installation.

Prime

⚠ WARNING ⚠

The fuel pump high-pressure fuel lines and fuel rail contain very high-pressure fuel. Never loosen any fittings while the engine is running. Personal injury and property damage can result.

To prime the engine use the OEM installed priming device. Typically, a priming pump is installed at or near the pre-filter. See the OEM's instructions for the number of strokes (hand primer) or the cycle time (electric priming pump) needed to prime the low pressure system.

NOTE: It is **not** necessary to vent air from the high pressure system before starting the engine.

NOTE: It is **not** necessary to pre-fill the on-engine fuel filter.

Operate the engine and check for leaks.

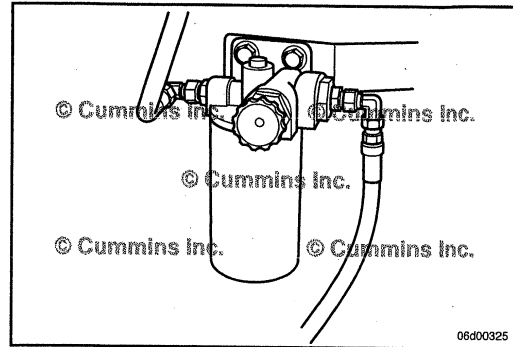

06d00325

Lubricating Oil and Filters Drain

⚠ WARNING ⚠

Some state and federal agencies have determined that used engine oil can be carcinogenic and cause reproductive toxicity. Avoid inhalation of vapors, ingestion, and prolonged contact with used engine oil. If not reused, dispose of in accordance with local environmental regulations.

⚠ WARNING ⚠

To reduce the possibility of personal injury, avoid direct contact of hot oil with your skin

Change the lubricating oil and filter(s) at the specified oil change interval. See the Maintenance Schedule to find the correct change interval for your application.

NOTE: For most engines use a container that can hold at least 20 liters [21 qt] of lubricating oil. Some engines may be equipped with an increased capacity oil pan requiring a container that will hold 28 liters [30 qt] of lubricating oil.

Operate the engine until the water temperature reaches 60°C [140°F].

Shut off the engine.

Remove the oil drain plug. Drain the oil immediately to be sure all the oil and suspended contaminants are removed from the engine.

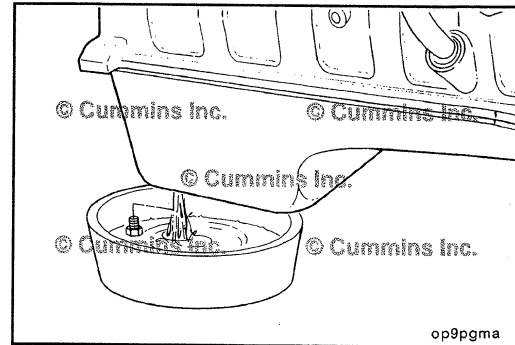

op9pgma

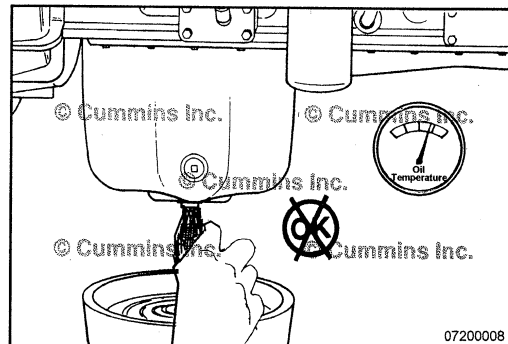

07200008

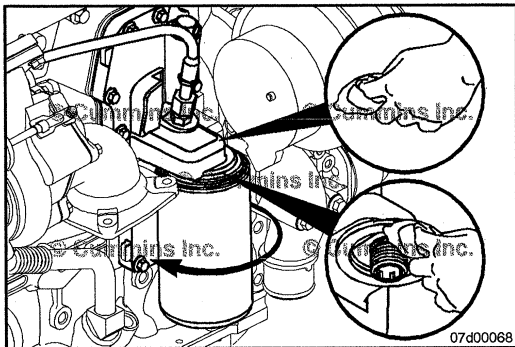

Remove

Clean the area around the lubricating oil filter head.



Use the oil filter wrench, Part Number 3400158, to remove the filter.

Clean the gasket surface of the filter head.

NOTE: The o-ring can stick on the filter head. Make sure it is removed before installing the new filter.

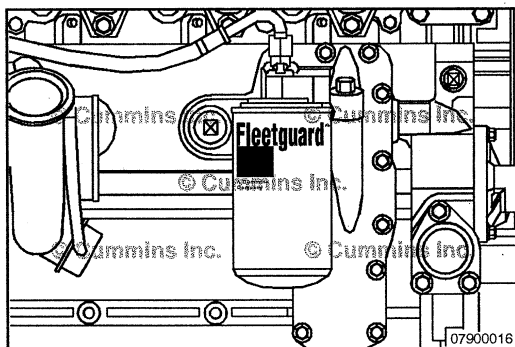

Install

Use the correct oil filter.

See Cummins/Fleetguard®/Nelson filter specifications for the correct oil filter part number.

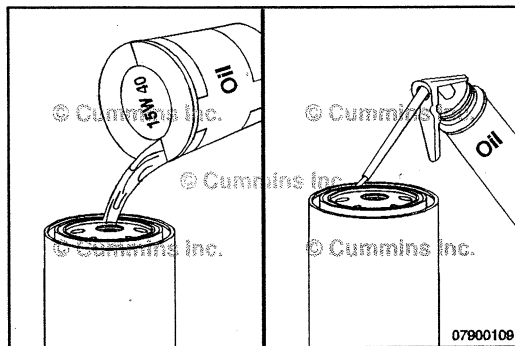

CAUTION

The lack of lubrication during the delay until the filter is pumped full of oil at start-up can damage the engine.

Use clean 15W-40 oil to coat the gasket surface of the filter.

Fill the filter with clean 15W—40 oil.

Apply a light film of lubricating oil to the gasket sealing surface before installing the filter.

NOTE: Be careful that **no** debris is poured into the filter. If using an oil supply with a metallic or plastic seal under the cap, be careful to peel the seal back. Puncturing the seal with a knife or sharp object can create debris in the oil container.

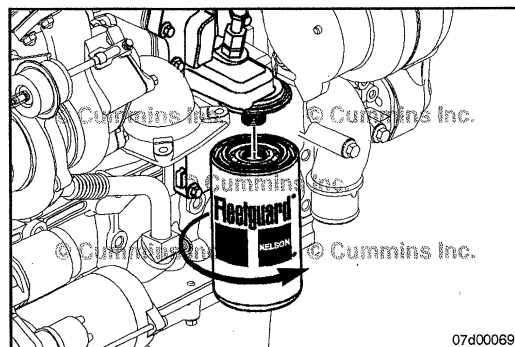

CAUTION

Mechanical overtightening of filter can distort the threads or damage the filter element seal.

Install the filter on the oil filter head. Tighten the filter until the gasket contacts the filter head surface.

Tighten 3/4 to 1 turn after gasket makes contact with the filter head.

QSB Series
Section 5 - Maintenance Procedures at 500 hours or 6 months

Fill

Clean and check the lubricating oil drain plug threads and sealing surface. Use new sealing washer, if damaged.
 Install the lubricating oil pan drain plug.
 Automotive and Industrial Applications:

Steel Oil Pan Drain Plug Torque			
	N•m		ft-lb
M18	60	MIN	44
M22	80	MIN	59

Cast Aluminum Oil Pan Drain Plug Torque			
	N•m		ft-lb
M22	60	MIN	44

NOTE: Use a high-quality 15W-40 multiviscosity lubricating oil, such as Valvoline® Premium Blue®, or its equivalent in Cummins engines. Choose the correct lubricating oil for your operating climate as outlined in Section V.

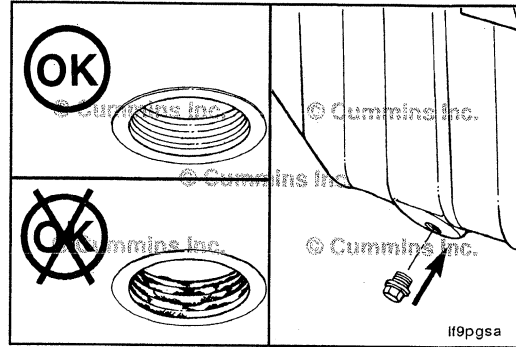

Fill the engine with clean lubricating oil to the proper level. Refer to Procedure 018-017 (Lubricating Oil System in Section V) for common oil pan capacities.

NOTE: Total system capacity assumes lubricating oil pan plus lubricating oil filter.

Some applications use a slightly different lubricating oil pan capacity, and all lubricating oil quantities **must** be adjusted accordingly. Contact your local Cummins Distributor if you have any questions.

The oil capacity for your engine can also be found by entering your engine serial number in QuickServe OnLine. (See section E of this manual to locate the ESN) Click on the "Parts" section, and select the Oil Pan. A description of the oil pan used on your engine, including fluid capacities, will be displayed.

Service Tip: If the oil capacity of the oil pan is not known, fill the lubricating oil pan to the smallest oil pan capacity listed in Procedure 018-017 (Lubricating Oil System in Section V) for the engine being worked on. Then add 1 quart of oil at a time until it reaches the high mark on the dipstick. Record the number of quarts added so that capacity is known the next time the oil is drained.

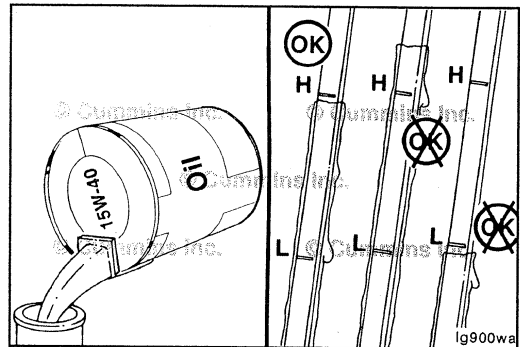

Section 5 - Maintenance Procedures at 500 hours or 6 months

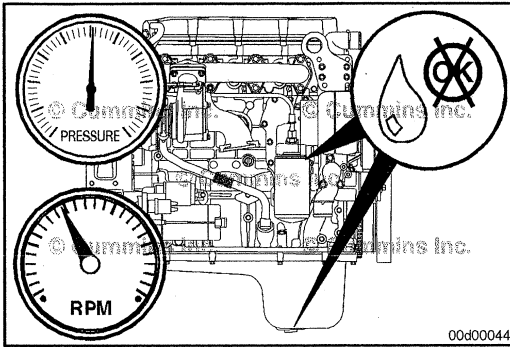

Idle the engine to inspect for leaks at the drain plug and, if replaced, the oil filter seal.

NOTE: Engine oil pressure **must** be indicated on the gauge within 15 seconds after starting. If oil pressure is **not** registered within 15 seconds, shut off the engine immediately to avoid engine damage. Confirm that the correct oil level is in the oil pan.

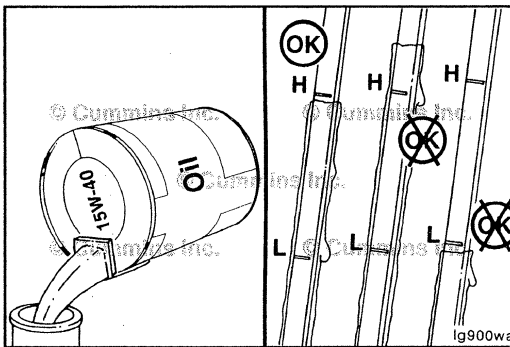

Shut off the engine. Wait approximately 5 minutes to let the oil drain from the upper parts of the engine. Check the level again.

Add oil as necessary to bring the oil level to the H (high) mark on the dipstick.

Section 6 - Maintenance Procedures at 1000 Hours or 1 Year

Section Contents

	Page
Cooling Fan Belt Tensioner	6-1
Maintenance Check.....	6-1
Fan Hub, Belt Driven	6-2
Maintenance Check.....	6-2
Maintenance Procedures - Overview	6-1
General Information.....	6-1



This Page Left Intentionally Blank

Maintenance Procedures - Overview

General Information

All maintenance checks and inspections listed in previous maintenance intervals **must** also be performed at this time, in addition to those listed under this maintenance interval.

Cooling Fan Belt Tensioner

Maintenance Check

With the engine stopped, check the tensioner arm, pulley stops and stops for cracks. If any cracks are noticed, the tensioner **must** be replaced.

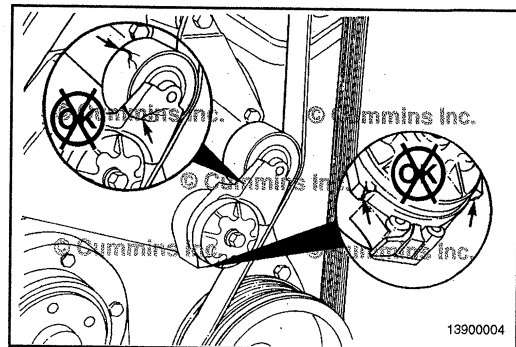

With the belt installed, verify that neither tensioner arm stops is in contact with the spring casing stop. If either of the stops is touching:

- Verify the correct belt part number is installed.
- If the correct belt is installed, replace the belt. Refer to Procedure 008-002, Drive Belt, Cooling Fan, in Section A.

After replacing the belt, if the tensioner arm stops are still in contact with the spring case stop, replace the tensioner.

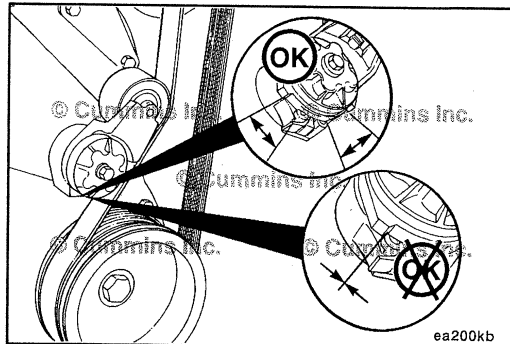

Check the location of the drive belt on the belt tensioner pulley. The belt should be centered on, or close to the middle of, the pulley. Misaligned belts, either too far forward or backward, can cause belt wear, belt roll-off failures, or increase uneven tensioner bushing wear.

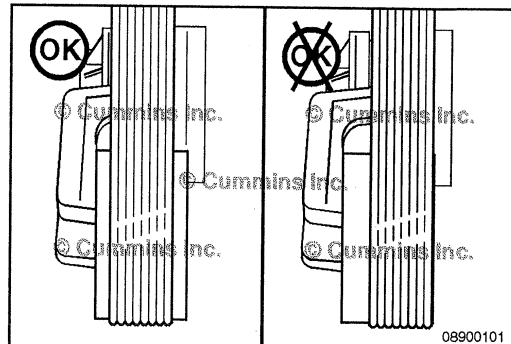

Section 6 - Maintenance Procedures at 1000 Hours or 1 Year

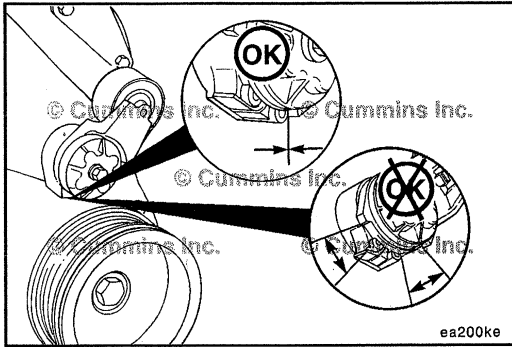

Remove the drive belt. Refer to Procedure 008-002, Drive Belt, Cooling Fan, in Section A.

With the belt removed, verify that the tensioner arm stop is in contact with the spring case stop. If they are not touching, the tensioner **must** be replaced.

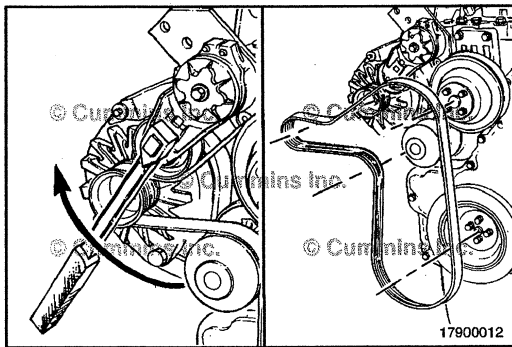

**Fan Hub, Belt Driven
Maintenance Check**

Remove the drive belt.

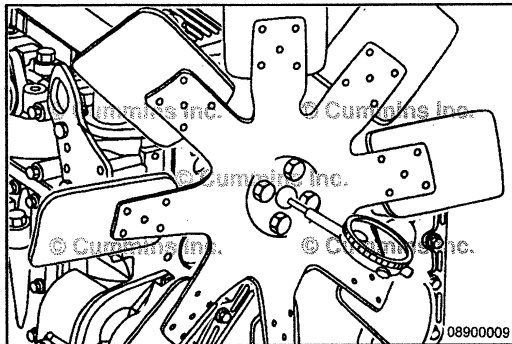

NOTE: The fan hub **must** rotate without any wobble or excessive end play.

Fan Hub End Play		
mm		in
0.15	MAX	0.006

Section 7 - Maintenance Procedures at 2000 Hours or 2 Years

Section Contents

	Page
Air Compressor Discharge Lines	7-1
General Information.....	7-1
Maintenance Check.....	7-1
Cooling System	7-2
Drain.....	7-3
Fill.....	7-6
Flush.....	7-4
General Information.....	7-2
Maintenance Procedures - Overview	7-1
General Information.....	7-1
Vibration Damper, Rubber	7-7
Inspect.....	7-7
Vibration Damper, Viscous	7-7
Inspect.....	7-7



This Page Left Intentionally Blank

Maintenance Procedures - Overview

General Information

All maintenance checks and inspections listed in previous maintenance intervals **must** also be performed at this time, in addition to those listed under this maintenance interval.

Air Compressor Discharge Lines

General Information

All air compressors have a small amount of lubricating oil carryover that lubricates the piston rings and moving parts. When this lubricating oil is exposed to normal air compressor operating temperatures over time, the lubricating oil will form varnish or carbon deposits. If the following maintenance check are not performed, the air compressor piston rings will wear and not seal correctly.

Maintenance Check



WARNING

Wear appropriate eye and face protection when using compressed air. Flying debris and dirt can cause personal injury.

Shut off the engine.

Open the drain valve on the wet tank to release the system air pressure.

Remove the air compressor discharge line from the air compressor. Location of the air compressor discharge line can be found in Flow Diagram, Compressed Air System in System Diagrams (Section D).

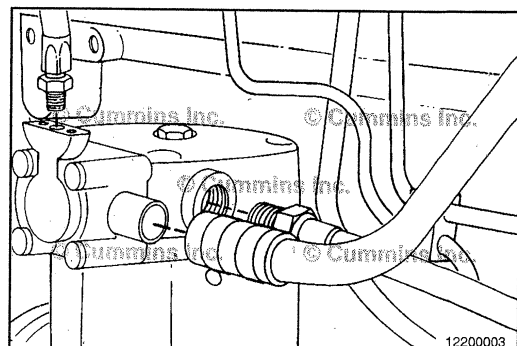
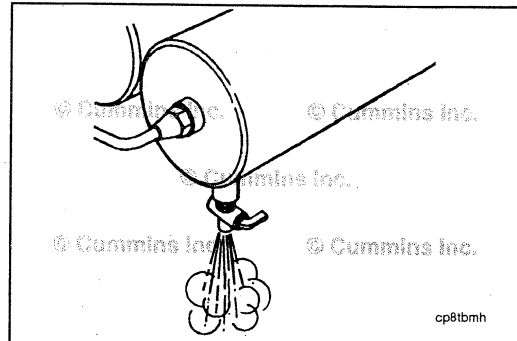

Section 7 - Maintenance Procedures at 2000 Hours or 2 Years

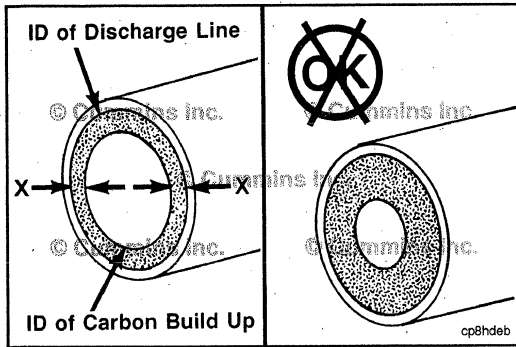

Measure the total carbon deposit thickness inside the air discharge line as shown. If the total carbon deposit ($X + X$) exceeds 2 mm [1/16 in], clean and inspect the cylinder head, the valve assembly, and the discharge line. Replace if necessary. Contact the Cummins Authorized Repair Location for procedures.

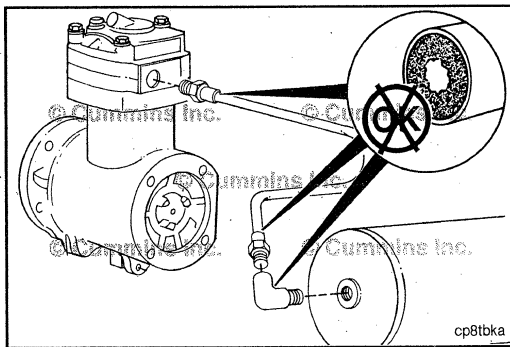

If the total carbon deposit exceeds specifications, continue checking the air discharge line connections up to the first tank until total carbon deposit is less than 2 mm [1/16 in]. Clean or replace any lines or connections that exceed this specification.

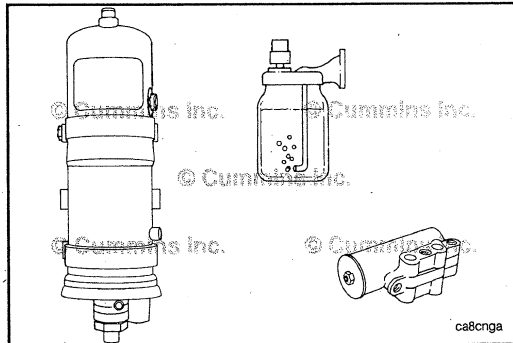

Inspect any air driers, splitter valves, pressure relief valves, and alcohol injectors for carbon deposits or malfunctioning parts. Inspect for air leaks. Maintain and repair the parts according to the manufacturer's specifications.

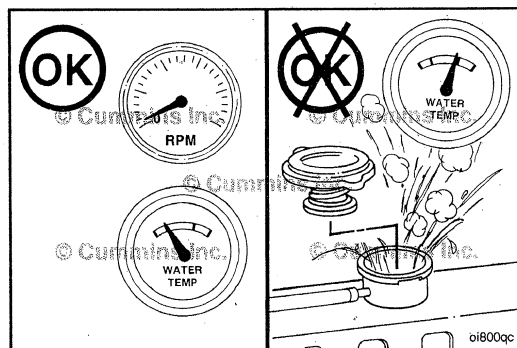

Cooling System
General Information

▲ WARNING ▲

Do not remove the pressure cap from a hot engine. Wait until the coolant temperature is below 50°C [120°F] before removing the pressure cap. Heated coolant spray or steam can cause personal injury.

NOTE: Never use a sealing additive to stop leaks in the coolant system. This can result in coolant system plugging and inadequate coolant flow, causing the engine to overheat.

The engine coolant level **must** be checked daily.

⚠ CAUTION ⚠

Do not add cold coolant to a hot engine. Engine castings can be damaged. Allow the engine to cool below 50°C [120°F] before adding coolant.

On applications that use a coolant recovery system, check to make sure the coolant is at the appropriate level on the coolant recovery tank, for the engine temperature.

Many coolant recovery/expansion tanks, also called "top tanks", have sight glasses (1) or are made of a clear material (not shown) to aid in checking the coolant level (2) without removing the radiator cap.

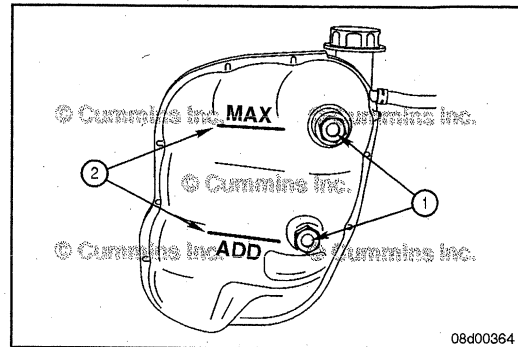

Fill the cooling system with coolant to the bottom of the fill neck in the radiator fill or recovery/expansion tank.

NOTE: Some radiators have two fill necks, both of which **must** be filled when the cooling system is drained.

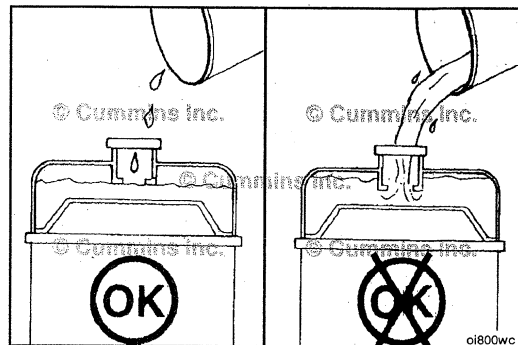

Drain

⚠ WARNING ⚠

Do not remove the pressure cap from a hot engine. Wait until the coolant temperature is below 50°C [122°F] before removing the pressure cap. Heated coolant spray or steam can cause personal injury.

Remove the radiator/expansion tank cap.

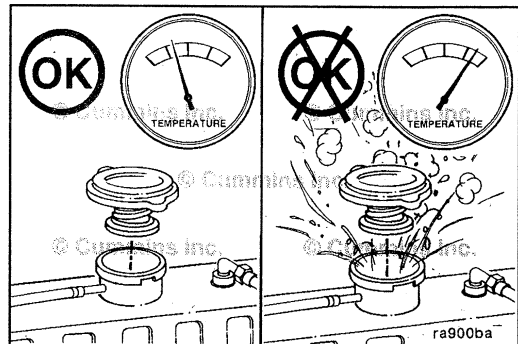

⚠ WARNING ⚠

Coolant is toxic. Keep away from children and pets. If not reused, dispose of in accordance with local environmental regulations.

Drain the cooling system by opening the drain valve on the radiator and removing the plug in the bottom of the water inlet. A drain pan with a capacity of 19 liters [5 gal.] will be adequate in most applications.

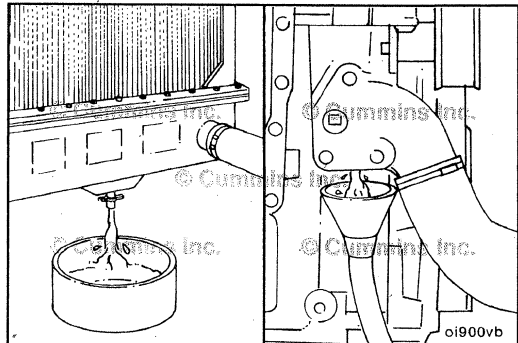

Section 7 - Maintenance Procedures at 2000 Hours or 2 Years

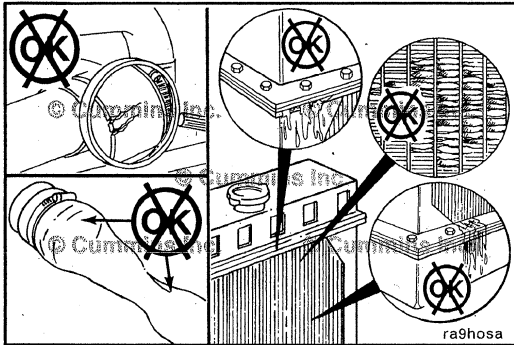

Check for damaged hoses and loose or damaged hose clamps. Replace as required. Check the radiator for leaks, damage, and buildup of dirt. Clean and replace as required.

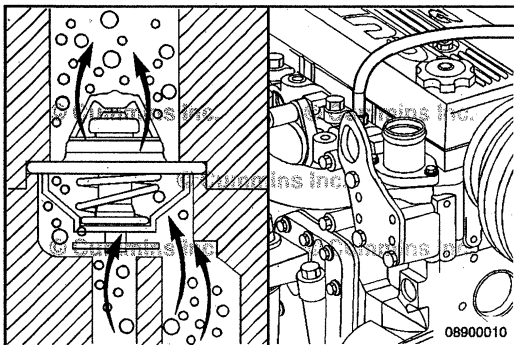

Flush

△CAUTION△

The system must be filled properly to prevent air locks. During filling, air must be vented from the engine coolant passages. Wait 2 to 3 minutes to allow air to be vented; then add mixture to bring the level to the top.

To be sure air is vented during the fill process:

- The thermostat has check balls that allow air to vent through the thermostat when the thermostat is closed.
- A deaeration port is located next to the water outlet connection which connects to the top tank/coolant recovery tank of the cooling system.

This provides adequate venting for a fill rate of 19 liters [5 gal.] per minute.



NOTE: An alternate to using sodium carbonate, as outlined in this procedure, is to use RESTORE™.

RESTORE™ is a heavy-duty cooling system cleaner that removes corrosion products, silica gel, and other deposits. The performance of RESTORE™ is dependent on time, temperature, and concentration levels. An extremely scaled or flow-restricted system, for example, can require higher concentrations of cleaners, higher temperatures, or longer cleaning times or the use of RESTORE Plus™. Up to twice the recommended concentration levels of RESTORE™ can be used safely. RESTORE Plus™ **must** be used **only** at its recommended concentration level. Extremely scaled or fouled systems can require more than one cleaning.

▲CAUTION▲

Do not install the radiator cap. The engine is to be operated without the cap for this process.

Fill the system with a mixture of sodium carbonate and water (or a commercially available equivalent).

NOTE: Adequate venting is provided for a fill rate of 19 liters [5 gal.] per minute.

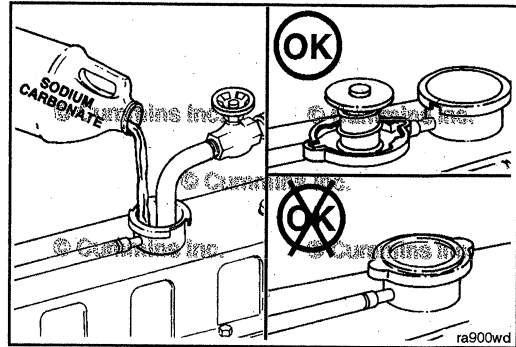

▲WARNING▲

Coolant is toxic. Keep away from children and pets. Dispose of in accordance with local environmental regulations.

Operate the engine for 5 minutes with the coolant temperature above 80°C [176°F].

Shut the engine off, and drain the cooling system.

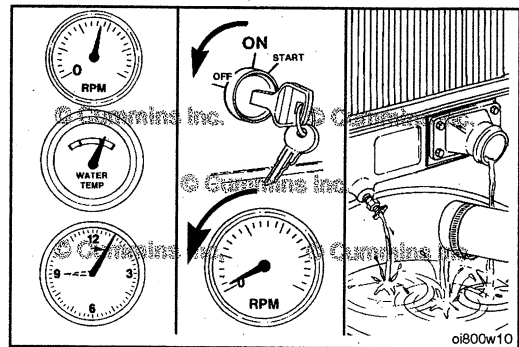

Fill the cooling system with clean water.

NOTE: Do not install the radiator cap.

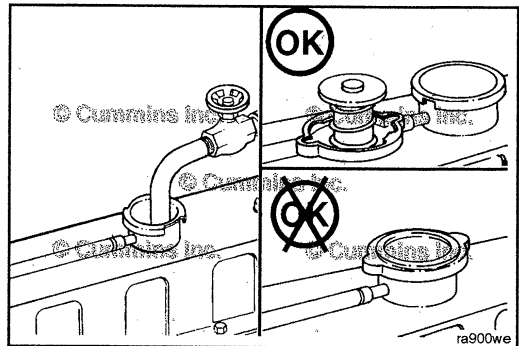

Operate the engine for 5 minutes with the coolant temperature above 80°C [176°F].

Shut the engine off, and drain the cooling system.

NOTE: If the water being drained is still dirty, the system must be flushed again until the water is clean.

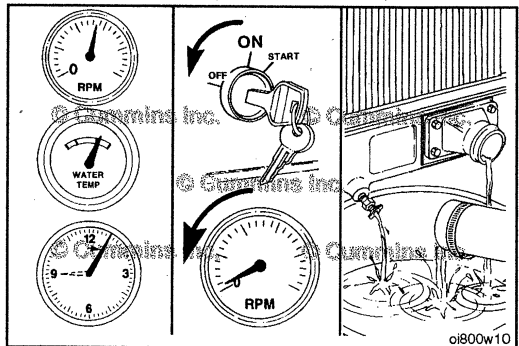

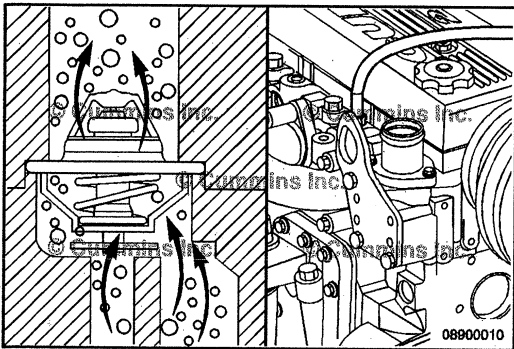

Fill

⚠CAUTION⚠

The system must be filled properly to prevent air locks. During filling, air must be vented from the engine coolant passages. Wait 2 to 3 minutes to allow air to be vented; then add mixture to bring the level to the top.

To be sure air is vented during the fill process:

- The thermostat has check balls that allow air to vent through the thermostat when the thermostat is closed.
- A deaeration port is located next to the water outlet connection which connects to the top tank/coolant recovery tank of the cooling system.

The system has a design fill rate of 19 liters [5 gal.] per minute.

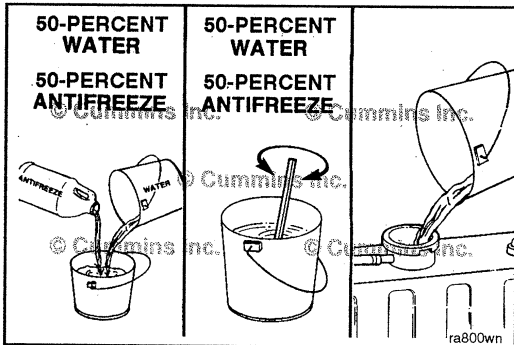

⚠CAUTION⚠

Never use water alone for coolant. Damage from corrosion can be the result of using water alone for coolant.

Use a mixture of 50-percent water and 50-percent ethylene glycol or propylene glycol antifreeze to fill the cooling system. Refer to the Cummins Coolant Requirements and Maintenance, Bulletin 3666132, for engine coolant specifications.

For cooling system capacity, refer to Procedure 018-018 (Cooling System) in Section V.

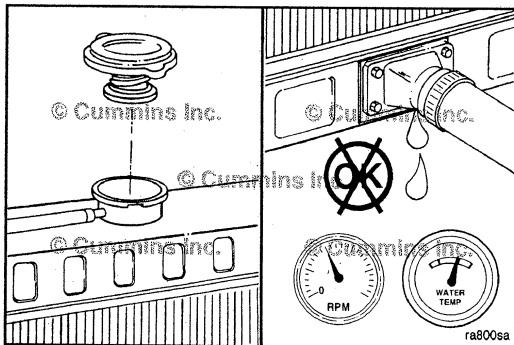

⚠WARNING⚠

Do not remove the pressure cap from a hot engine. Wait until the coolant temperature is below 50°C [122°F] before removing the pressure cap. Heated coolant spray or steam can cause personal injury.

Install the pressure cap. Operate the engine until it reaches a temperature of 80°C [180°F] and check for coolant leaks.

Check the coolant level again to make certain the system is full of coolant or that the coolant level has risen to the hot level in the recovery/expansion tank in the system, if so equipped.

Vibration Damper, Rubber Inspect

Check the index lines (A) in the vibration damper hub (B) and the inertia member (C). If the lines are more than 1.59 mm [1/16 in] out of alignment, replace the vibration damper.

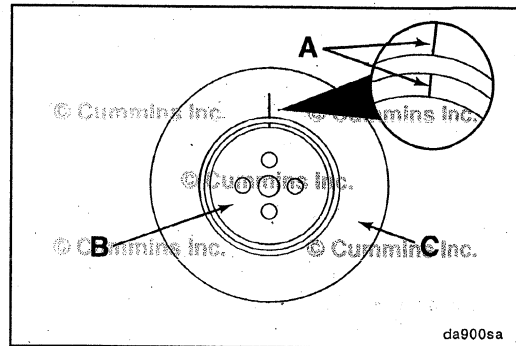

Inspect the rubber member for deterioration. If pieces of rubber are missing or if the elastic member is more than 3.18 mm [1/8 in] below the metal surface, replace the damper.

Look for forward movement on the damper ring on the hub. Replace the vibration damper if any movement is detected.

For vibration damper location, refer to Engine Diagrams in Engine Identification (Section E).

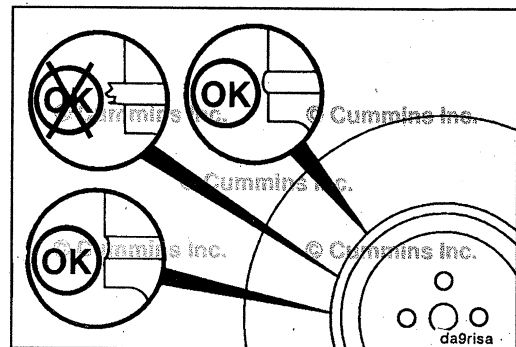

Vibration Damper, Viscous Inspect

⚠ CAUTION ⚠

The silicone fluid in the vibration damper will become solid after extended service and will make the damper inoperative. An inoperative vibration damper can cause major engine or drivetrain failures.

Check the vibration damper for evidence of fluid loss, dents, and wobble. Inspect the vibration damper thickness for any deformation or raising of the damper cover plate.

If any of these conditions are identified, contact your local Cummins Authorized Repair Location to replace the vibration damper.

Viscous dampers have a limited life. The maximum damper life specifications are located in Maintenance Specifications (Section V).

For vibration damper location, refer to Engine Diagrams in Engine Identification (Section E).

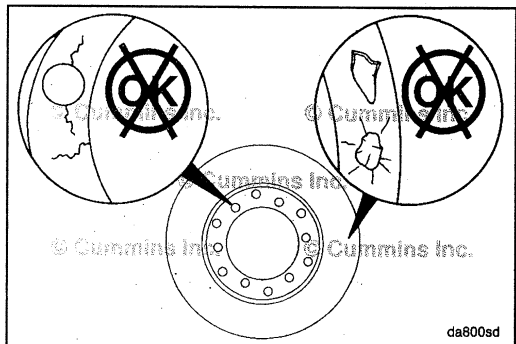

Section 8 - Maintenance Procedures at 5000 hours or 4 years

Section Contents

	Page
Maintenance Procedures - Overview	8-1
General Information.....	8-1
Overhead Set	8-1
Adjust.....	8-3
Finishing Steps.....	8-7
Install.....	8-5
Preparatory Steps.....	8-1
Remove.....	8-1



This Page Left Intentionally Blank

Maintenance Procedures - Overview

General Information

All maintenance checks and inspections listed in previous maintenance intervals **must** also be performed at this time, in addition to those listed under this maintenance interval.

Overhead Set

Preparatory Steps

▲ WARNING ▲

Batteries can emit explosive gases. To reduce the possibility of personal injury, always ventilate the compartment before servicing the batteries. To reduce the possibility of arcing, remove the negative (-) battery cable first and attach the negative (-) battery cable last.

Disconnect the batteries.

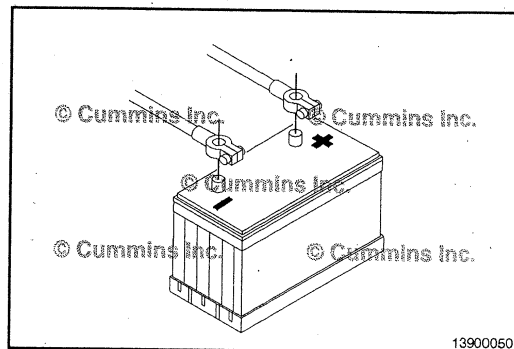

Remove

▲ WARNING ▲

Wear appropriate eye and face protection when using compressed air. Flying debris and dirt can cause personal injury.

Prior to removing any components, clean around the mounting fasteners and sealing joints with compressed air to remove any loose debris.

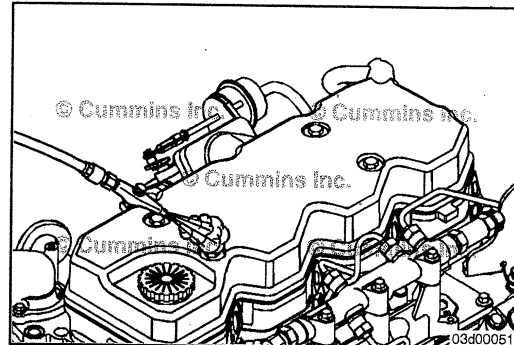

Section 8 - Maintenance Procedures at 5000 hours or 4 years

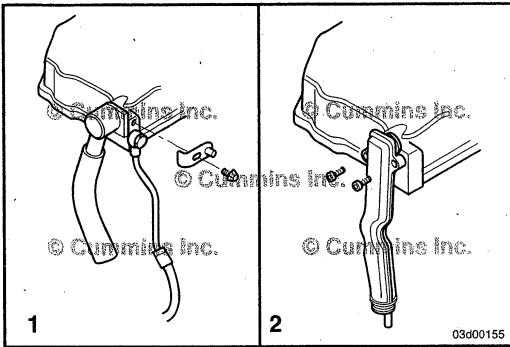

Disconnect the breather tube connection at the back of the rocker lever cover.

In general, two type of breather tube connections are used at the rocker lever cover:

1. A clamping plate and capscrew hold the breather tube connection to the rocker lever cover. Remove the capscrew and clamping plate to disconnect the breather tube connection from the rocker lever cover.
2. 1 or 2 Capscrew(s) directly mount the breather tube connection to the rocker lever cover. Remove the capscrew(s) to disconnect the breather tube connection from the rocker lever cover.

NOTE: Some breather tube connections use internal Torx capscrews to secure the breather tube connection to the rocker lever cover.

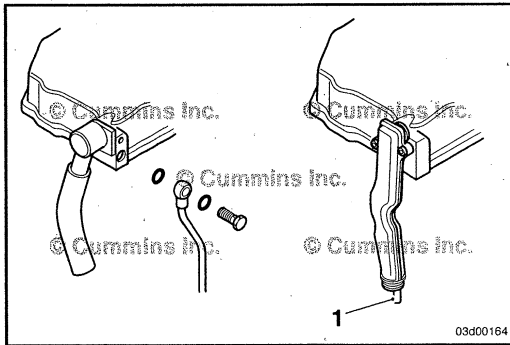

If equipped, at the rear of the rocker lever cover, remove the banjo bolt and sealing washers connecting the breather oil drain line to the rocker lever cover.

NOTE: Not all engines with an internal mounted crankcase breather are equipped with an external breather oil drain line. On some engines the breather oil drain line is internal to the breather connection tube (1).

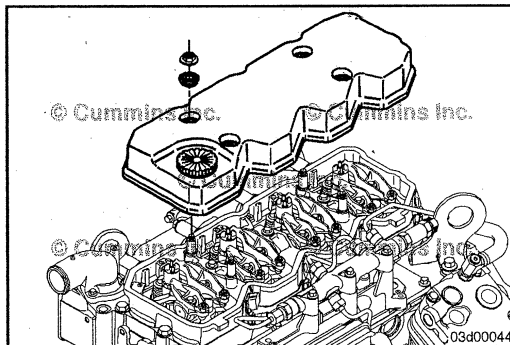

NOTE: Do **not** remove the rocker lever gasket on engines in which the rocker lever cover gasket is fit into a groove at the base of the rocker lever cover. The gasket is reusable. Once the gasket is removed from the rocker lever cover it **must** be replaced.

Remove the mounting nuts and isolators from the rocker lever cover.

NOTE: If equipped, it may be necessary to gently pry the breather tube connection from the back of the rocker lever cover while removing.

Remove the rocker lever cover.

QSB Series

Section 8 - Maintenance Procedures at 5000 hours or 4 years

NOTE: Check the gasket while it is installed in the valve cover. Once the gasket is removed from the cover it **must** be replaced.



Check the gasket for cracks on the sealing surface.

Replace the gasket if damage is present.

Replace the gasket if it is removed from the groove in the rocker lever cover.

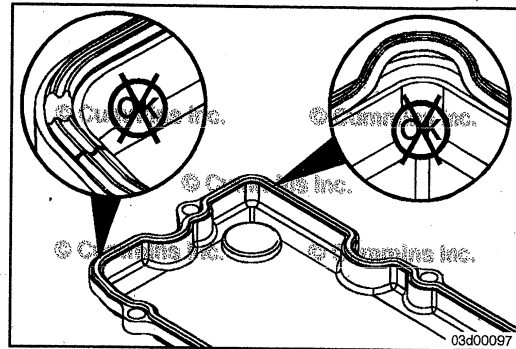

Inspect the rubber isolators for cracks.

Replace if cracked or broken.

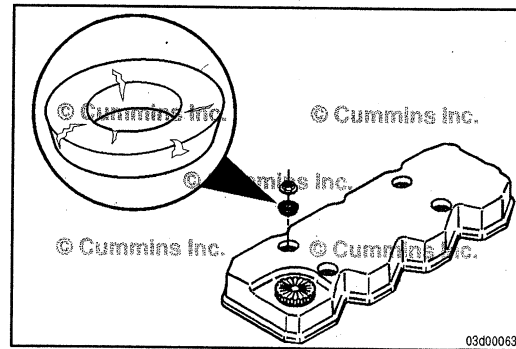

NOTE: If the gasket has been removed from the rocker lever cover, a new gasket **must** be used.

If replacing the rocker lever gasket, the following installation procedure must be used when installing the press-in gasket.

1. Press the molded gasket into the corners of the rocker lever cover
2. Press the remaining gasket into the rocker lever cover.

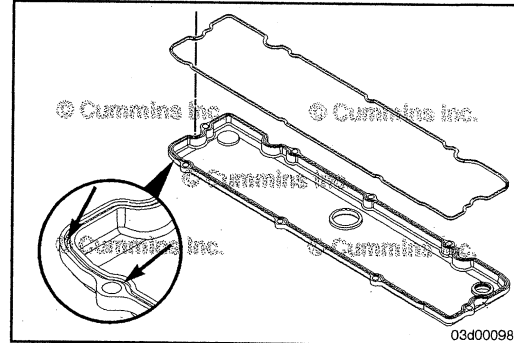

Adjust

NOTE: Engine coolant temperature must be less than 60° C [140°F].

Using the barring tool, Part Number 3824591, rotate the crankshaft until the Number 1 cylinder is at TDC.

TDC can be determined by the following method:

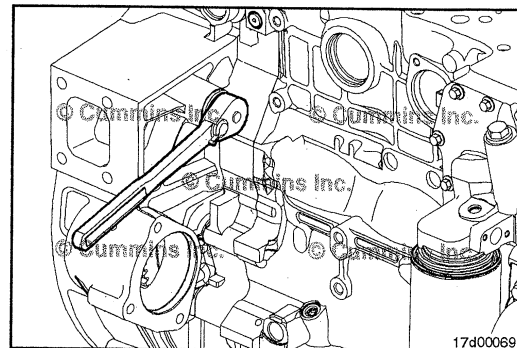

Section 8 - Maintenance Procedures at 5000 hours or 4 years

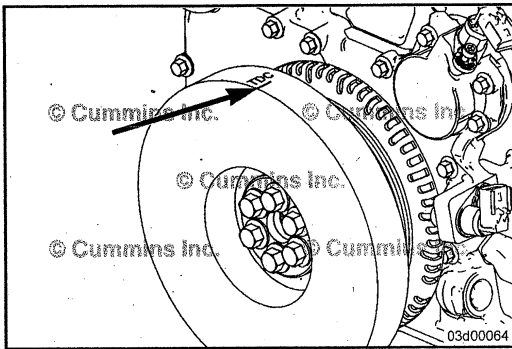

Align the vibration damper/crankshaft speed indicator ring so that the TDC indicator is at the 12 o'clock position. If both number 1 cylinder rocker levers are loose, move to the following steps. If both number 1 cylinder rocker levers are **not** loose, rotate the crankshaft 360 degrees.

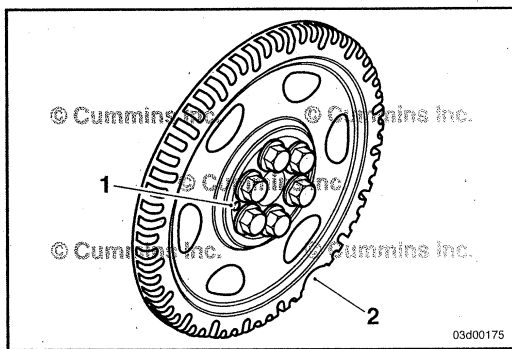

NOTE: If no TDC mark is present on either the vibration damper or the crankshaft speed indicator ring, align the large gap in the crankshaft speed indicator ring to the 5-o'clock position (2). The dowel pin should also be visible in the 9-o'clock position (1). Check that both No. 1 cylinder rocker levers are loose. If they are **not** loose, rotate the crankshaft 360 degrees and recheck.

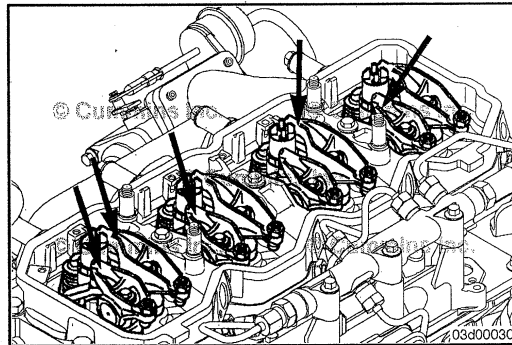

With the engine in this position, lash can be checked on the following rocker arms:

(E = exhaust, I = Intake)



Four-cylinder 1I, 1E, 2I, and 3E

Six-cylinder 1I, 1E, 2I, 3E, 4I, and 5E.

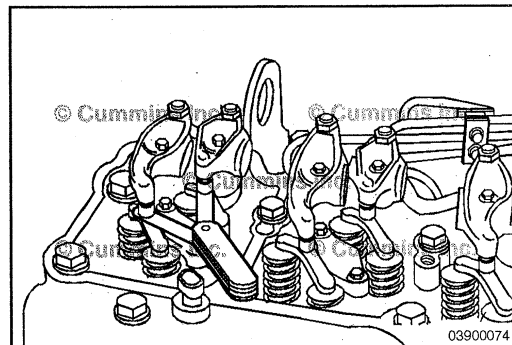

Lash Check Limits

	mm		in	
Intake	0.152	MIN	0.006	
	0.381	MAX	0.015	
Exhaust	0.381	MIN	0.015	
	0.762	MAX	0.030	

NOTE: Checking the overhead setting is usually performed as part of a troubleshooting procedure, and resetting is **not** required during checks as long as the lash measurements are within the above ranges.

QSB Series

Section 8 - Maintenance Procedures at 5000 hours or 4 years

NOTE: The clearance is correct when some resistance is "felt" when the feeler gauge is slipped between the crosshead and the rocker lever socket.



Measure lash by inserting a feeler gauge between the crosshead and the rocker lever socket. If the lash measurement is out of specification, loosen the locknut, and adjust the lash to nominal specifications.



Lash Specifications		
	mm	in
Intake	0.254	0.010
Exhaust	0.508	0.020

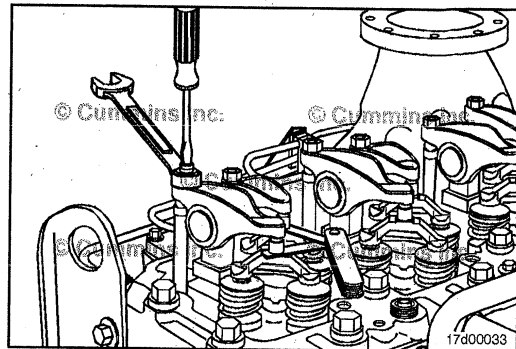

Tighten the locknut and remeasure.

Torque Value: 24 N•m [212 in-lb]

Using barring tool, Part Number 3824591, rotate the crankshaft 360 degrees.



Following the same steps and specifications as previously stated, measure lash for the following rockers:

(E = Exhaust, I = Intake).

Four-cylinder 2E, 3I, 4E, and 4I:

Six-cylinder 2E, 3I, 4E, 5I, 6I, and 6E.

Reset if out of specification.

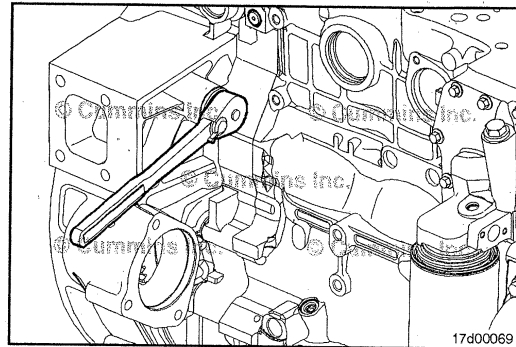

Install

Stud Mounted Rocker Lever Cover.

Install the rocker lever cover over the mounting capscrews.

Install the isolators and mounting nuts.

Tighten the mounting nuts.

Torque Value: 24 N•m [18 ft-lb]

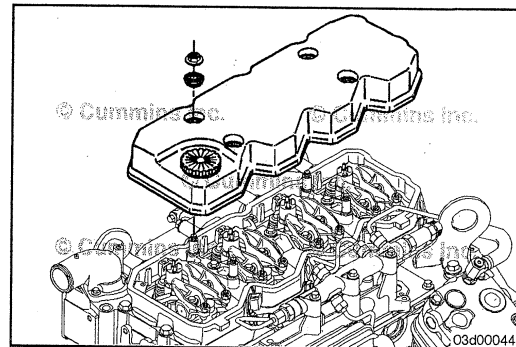

Capscrew Mounted Rocker Lever Cover.

Install the rocker lever cover.

Install the mounting capscrews and isolators.

Tighten the mounting capscrews.

Torque Value: 24 N•m [18 ft-lb]

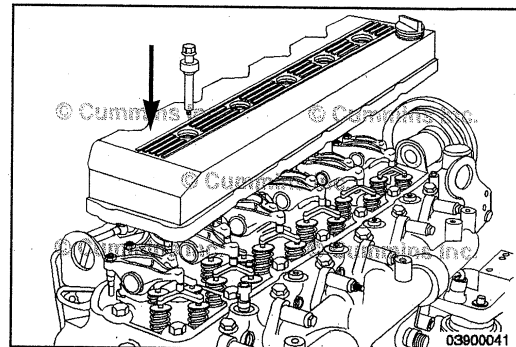

Section 8 - Maintenance Procedures at 5000 hours or 4 years

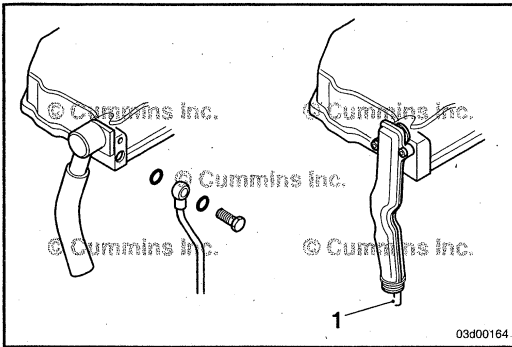

If equipped, at the rear of the rocker lever cover, install the banjo bolt and sealing washers connecting the breather oil drain line to the rocker lever cover.

Torque Value: 12 N•m [106 in-lb]

NOTE: Not all engines with an internal mounted crankcase breather are equipped with an external breather oil drain line. On some engines the breather oil drain line is internal to the breather connection tube (1).

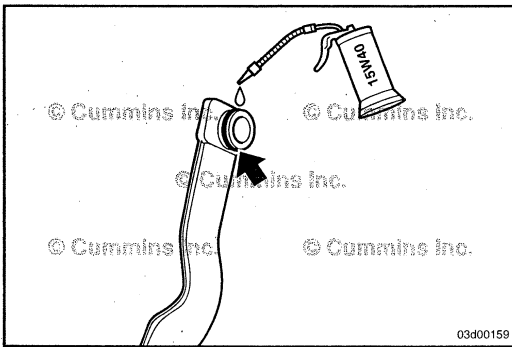

Prior to connecting the breather connection tube to the rocker lever cover, apply clean engine oil to the o-ring located on the breather tube connection.

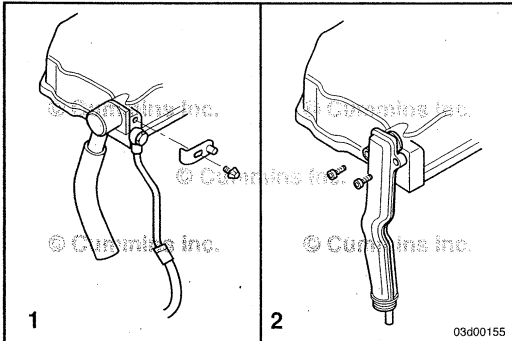

Connect the breather tube connection to the rocker lever cover.

In general, two types of breather tube connections are used at the rocker lever cover:

1. A clamping plate and capscrew hold the breather tube connection to the rocker lever cover. Install the capscrew and clamping plate to connect the breather tube connection to the rocker lever cover.
2. 1 or 2 Capscrew(s) directly mount the breather tube connection to the rocker lever cover. Install the capscrew(s) to connect the breather tube connection to the rocker lever cover.

Tighten the Capscrew(s).

Torque Value: 10 N•m [89 in-lb]

NOTE: Some breather tube connections use internal Torx capscrews to secure the breather tube connection to the rocker lever cover.

Finishing Steps

▲ WARNING ▲

Batteries can emit explosive gases. To reduce the possibility of personal injury, always ventilate the compartment before servicing the batteries. To reduce the possibility of arcing, remove the negative (-) battery cable first and attach the negative (-) battery cable last.

Connect the batteries.

Operate the engine and check for leaks.

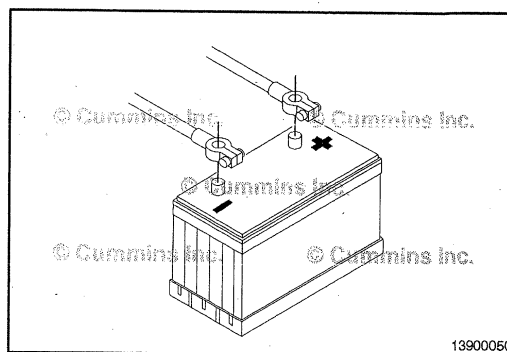

Section A - Adjustment, Repair, and Replacement

Section Contents

	Page
Alternator	A-1
Finishing Steps.....	A-6
General Information.....	A-1
Initial Check.....	A-1
Install.....	A-5
Preparatory Steps.....	A-3
Remove.....	A-4
Test.....	A-2
Charge-Air Cooler	A-6
Clean.....	A-6
Inspect for Reuse.....	A-7
Leak Test.....	A-7
Pressure Differential Test.....	A-9
Temperature Differential Test.....	A-8
Coolant Thermostat	A-10
Clean and Inspect for Reuse.....	A-12
Finishing Steps.....	A-14
General Information.....	A-10
Install.....	A-14
Preparatory Steps.....	A-11
Remove.....	A-12
Cooling Fan Belt Tensioner	A-15
Maintenance Check.....	A-15
Drive Belt, Cooling Fan	A-16
Inspect for Reuse.....	A-16
Install.....	A-17
Remove.....	A-16
Fan Spacer and Pulley	A-17
Inspect for Reuse.....	A-17
Install.....	A-18
Preparatory Steps.....	A-17
Remove.....	A-17
Starting Motor	A-18
Clean and Inspect for Reuse.....	A-20
Install.....	A-21
Cummins Branded Starters.....	A-22
Non-Cummins Branded Starters.....	A-22
Measure.....	A-21
Remove.....	A-19
Rotation Check.....	A-18

This Page Left Intentionally Blank

Alternator General Information

Due to the number of different alternator brands and configurations, the following procedure has been generalized to cover the most common configurations. Consult the alternator manufacturer for any information that is **not** covered in this procedure.

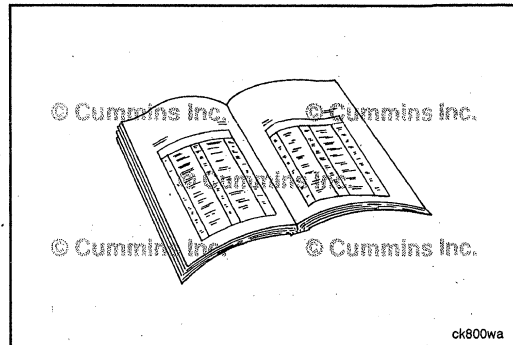

Initial Check

Check the drive belt and alternator pulley to be sure the alternator is rotating properly.

If any problems exist, check the following:

1. If the drive belt is slipping on the alternator pulley, refer to Procedure 008-002 to inspect the drive belt and Procedure 008-087 to inspect the belt tensioner
2. Remove the drive belt. Refer to Procedure 008-002. Check if the alternator pulley is loose on the shaft. If loose, remove the pulley and inspect for damage. Refer to the alternator manufacturer's and/or OEM instructions
3. If the alternator will **not** rotate or does **not** rotate freely, the alternator **must** be replaced. See the remove and install portion of this procedure.

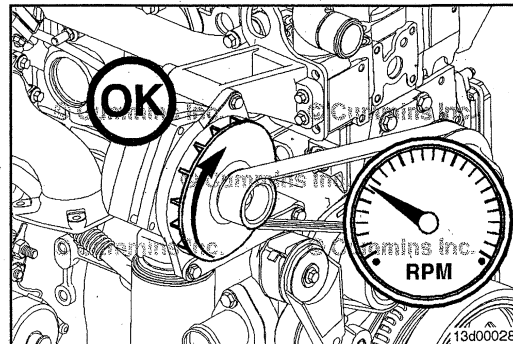

⚠ WARNING ⚠

Batteries can emit explosive gases. To reduce the possibility of personal injury, always ventilate the compartment before servicing the batteries. To reduce the possibility of arcing, remove the negative (-) battery cable first and attach the negative (-) battery cable last.

Check the battery and all wiring connections.

Inspect the wiring for defects.

Check all connections for tightness and cleanliness, including the slip connectors at the alternator and engine compartment bulkhead, and connections at the battery.

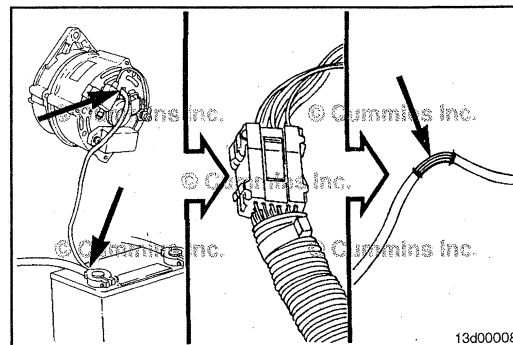

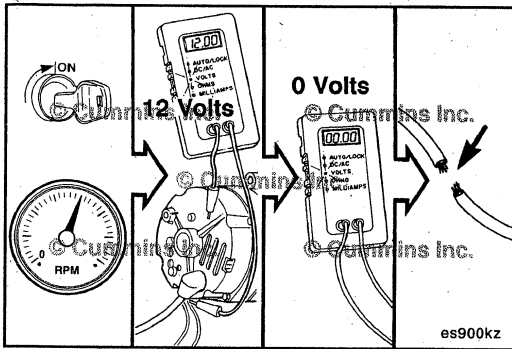

Test

NOTE: Any multimeter reading of zero voltage indicates an open circuit.



Check for open circuits.

Turn the keyswitch to the ON position.

Connect a multimeter, Part Number 3164488 or 3164489, to the following locations:

Delco Alternators

1. Alternator "BAT" terminal to ground
2. Alternator blade terminal "number 1" to ground
3. Alternator blade terminal "number 2" to ground.

Locate and repair the open circuit.

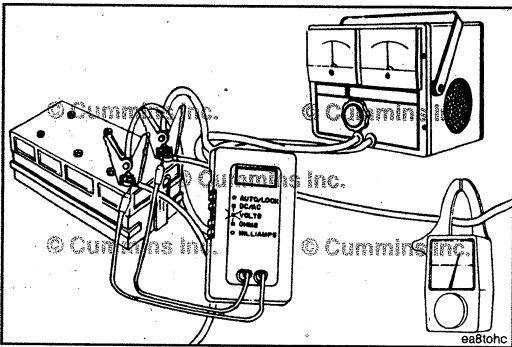

Connect a carbon-pile load (battery/alternator tester) across the batteries in one of the battery boxes.

Clamp an induction pickup-type ampere-hour meter around the battery cable; or use the digital multimeter, Part Number 3164488 or 3164489, with the clamp-on current probe, Part Number 3164490.

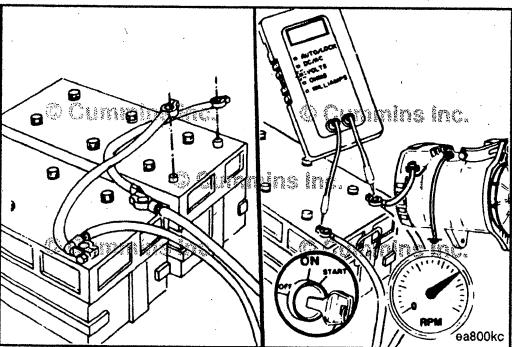

▲ WARNING ▲

Batteries can emit explosive gases. To reduce the possibility of personal injury, always ventilate the compartment before servicing the batteries. To reduce the possibility of arcing, remove the negative (-) battery cable first and attach the negative (-) battery cable last.



▲ WARNING ▲

Acid is extremely dangerous and can damage the machinery and can also cause serious burns. Always provide a tank of strong soda water as a neutralizing agent when servicing the batteries. Wear goggles and protective clothing to reduce the possibility of serious personal injury.

Disconnect any cables that lead to any other battery boxes in the circuit, negative (-) cables first.

Operate the engine at high idle; and measure the alternator voltage output to the batteries with digital multimeter, Part Number 3164488 or 3164489. Refer to the OEM specifications.

QSB Series
Section A - Adjustment, Repair, and Replacement

Operate the engine at high idle and adjust the carbon-pile load-testing equipment to apply the maximum rated amperage load to the alternator. Refer to the OEM specifications.

NOTE: The alternator maximum rated amperage output is normally stamped or labeled on the alternator.

Measure the alternator amperage output. Refer to the OEM specifications.

If the alternator output (amps) is **not** within 10 percent of rated output, repair or replace the alternator. Refer to the OEM troubleshooting and repair manual for repair procedures.

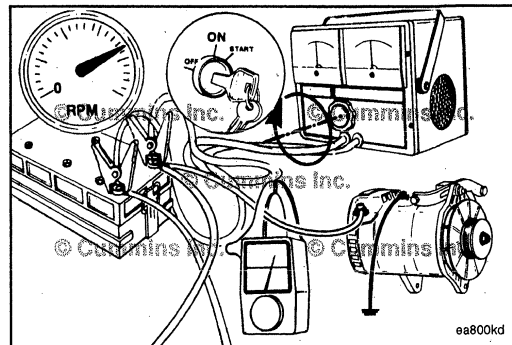

▲ WARNING ▲

Batteries can emit explosive gases. To reduce the possibility of personal injury, always ventilate the compartment before servicing the batteries. To avoid arcing, remove the negative (-) battery cable first and attach the negative (-) battery cable last.

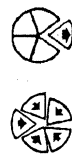

▲ WARNING ▲

Acid is extremely dangerous and can damage the machinery and can also cause serious burns. Always provide a tank of strong soda water as a neutralizing agent when servicing the batteries. Wear goggles and protective clothing to reduce the possibility of serious personal injury.

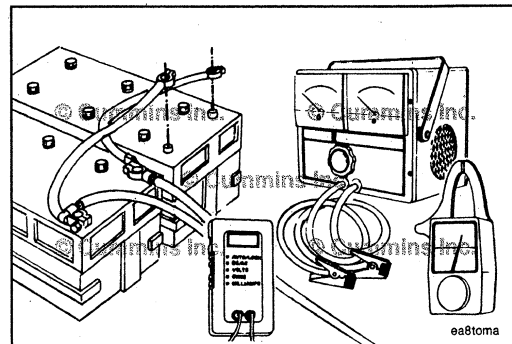

Shut off the engine, and remove the test equipment.

Connect all battery cables, negative (-) cable last.

Preparatory Steps

▲ WARNING ▲

Batteries can emit explosive gases. To reduce the possibility of personal injury, always ventilate the compartment before servicing the batteries. To reduce the possibility of arcing, remove the negative (-) battery cable first and attach the negative (-) battery cable last.



▲ WARNING ▲

Acid is extremely dangerous and can damage the machinery and can also cause serious burns. Always provide a tank of strong soda water as a neutralizing agent when servicing the batteries. Wear goggles and protective clothing to reduce the possibility of serious personal injury.

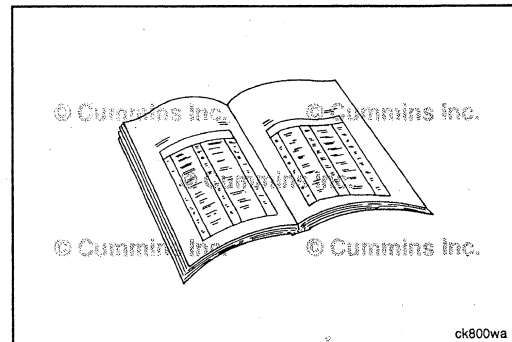

- Disconnect the batteries. Refer to the OEM instructions.
- Remove the drive belt from the alternator pulley. Refer to Procedure 008-002.
- Tag and label all wires on the alternator.
- Disconnect the wires.

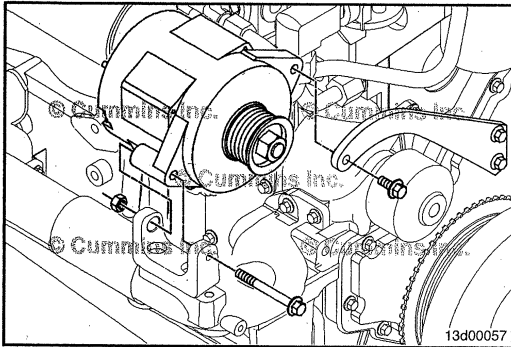

Remove

Spool Mount

Remove the upper alternator link capscrew.
Remove the mounting capscrew and nut at the bottom of the alternator and alternator mounting bracket.
Remove the alternator.

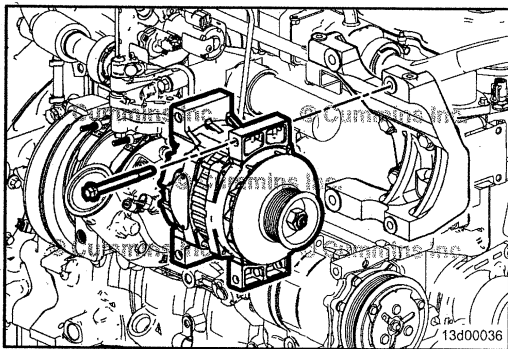

Pad Mount

Remove the alternator mounting capscrews.
Remove the alternator.

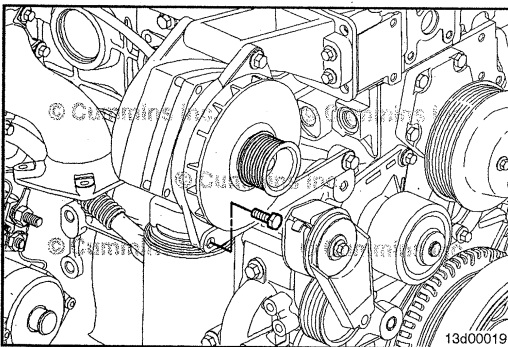

Hinge Mount

Remove the alternator link capscrew.

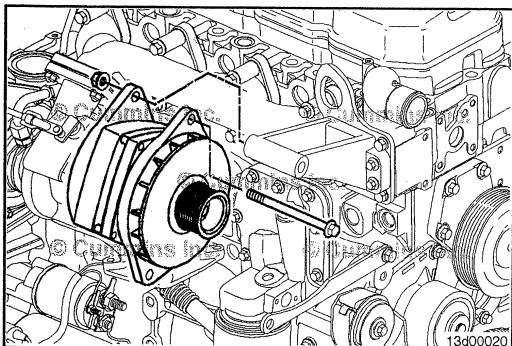

Remove the alternator mounting capscrew.
Remove the alternator.

Install

Spool Mount

Install the alternator and the bottom alternator mounting capscrew and nut.

Install the upper alternator link mounting capscrew at the top of the alternator.

Tighten the capscrews.

Torque Value:			
Lower Mounting Capscrew	40 N•m	[30 ft-lb]	
Upper Link Mounting Capscrew	24 N•m	[212 in-lb]	

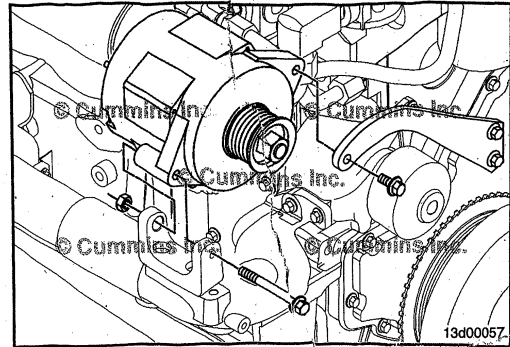

Pad Mount

Install the alternator.

Install and tighten the alternator mounting capscrews.

Torque Value:			
M10 Capscrew	36 N•m	[27 ft-lb]	
M12 Capscrew	64 N•m	[47 ft-lb]	

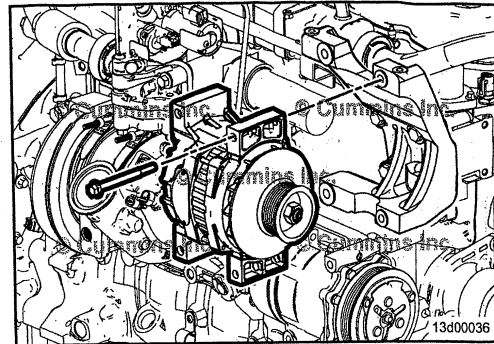

Hinge Mount

Install the alternator.

Install and tighten the alternator mounting capscrew.

Torque Value:	40 N•m	[30 ft-lb]	
----------------------	--------	--------------	--

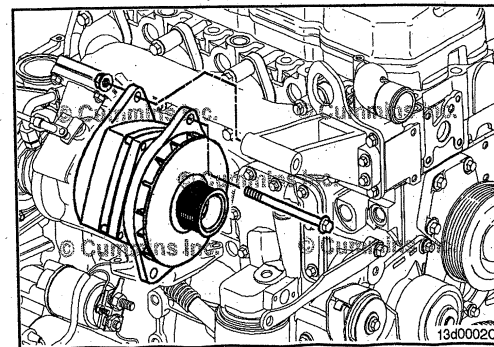

Install the alternator link capscrew.

Torque Value:	24 N•m	[212 in-lb]	
----------------------	--------	---------------	--

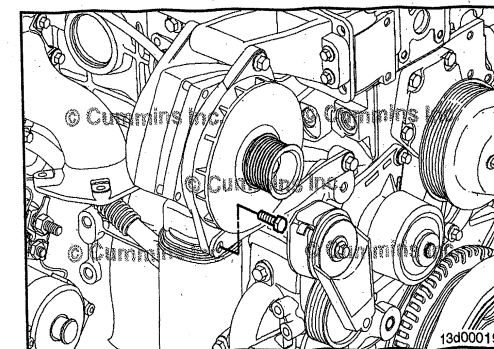

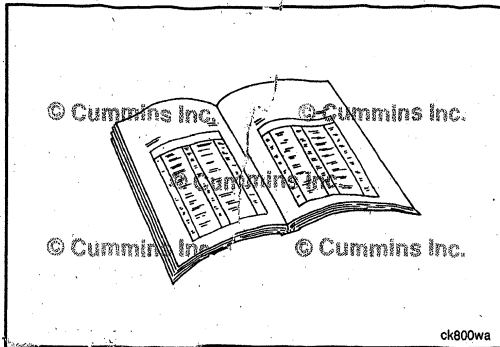

Finishing Steps



⚠ WARNING ⚠

Batteries can emit explosive gases. To reduce the possibility of personal injury, always ventilate the compartment before servicing the batteries. To avoid arcing, remove the negative (-) battery cable first and attach the negative (-) battery cable last.

⚠ WARNING ⚠

Acid is extremely dangerous and can damage the machinery and can also cause serious burns. Always provide a tank of strong soda water as a neutralizing agent when servicing the batteries. Wear goggles and protective clothing to reduce the possibility of serious personal injury.

- Connect all wires to the alternator.
- Install the drive belt. Refer to Procedure 008-002.
- Connect the batteries. Refer to the OEM instructions.
- Operate engine to check for proper operation.

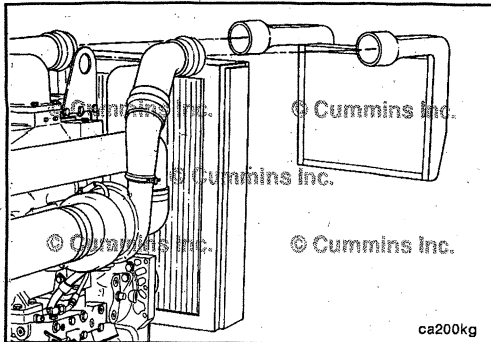

Charge-Air Cooler

Clean



If the engine experiences a turbocharger failure or any other occasion where oil or debris is put into the charge air cooler, the charge air cooler **must** be cleaned.

Remove the charge air cooler piping and charge air cooler from the vehicle. Refer to the manufacturer's instructions.

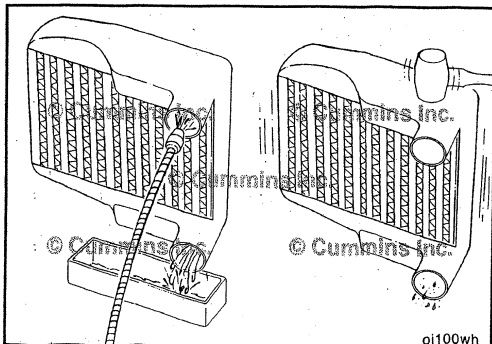

⚠ CAUTION ⚠

Do not use caustic cleaners to clean the charge air cooler. Damage to the charge air cooler will result.

Flush the charge air cooler internally with solvent in the opposite direction of normal airflow. Shake the charge air cooler and lightly tap on the end tanks with a rubber mallet to dislodge trapped debris. Continue flushing until all debris or oil is removed.

NOTE: Be sure the tubes are in the vertical direction when flushing.

If the debris **cannot** be totally removed from the charge air cooler, the charge air cooler **must** be replaced.

QSB Series
Section A - Adjustment, Repair, and Replacement

After the charge air cooler has been thoroughly cleaned of all oil and debris with solvent, wash the charge air cooler internally with hot soapy water to remove the remaining solvent. Rinse thoroughly with clean water.

Blow compressed air through the inside of the charge air cooler in the opposite direction of normal air flow until the charge air cooler is dry internally.

⚠CAUTION⚠

The charge air cooler must be rinsed, dried, and free of solvent, oil, and debris or engine damage will result.

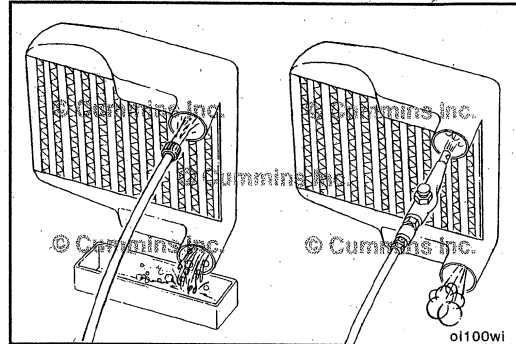

Inspect for Reuse

Inspect the charge air cooler for cracks, holes, or damage.

Inspect the tubes, the fins, and the welds for tears, breaks, or other damage. If any damage causes the charge air cooler to fail the air leak check mentioned earlier in this procedure, the charge air cooler **must** be replaced.

Install the charge air cooler and charge air cooler piping on the vehicle. Refer to the manufacturer's instructions.

NOTE: Always clean and inspect the charge air cooler piping and hoses prior to installation.

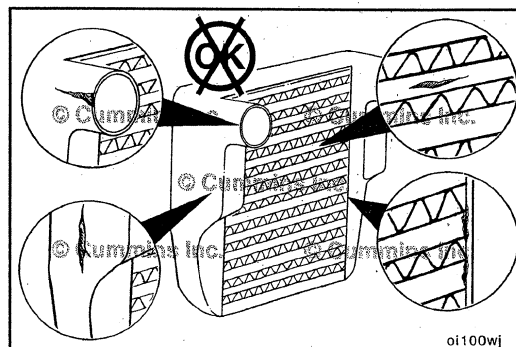

Leak Test

To check the charge air cooler for cracked tubes or header, remove the inlet and outlet hoses from the cooler. The charge air cooler does **not** have to be removed from the chassis.

⚠WARNING⚠

To prevent possible injury if either plug blows off during the test, secure safety chains on the test plugs to any convenient capscrew on the radiator assembly. This test must not be performed without securely fastened safety chains.

Install a plug or cap over the outlet side of the cooler. Install a pressure gauge and a regulated shop air supply line with a shutoff valve to the inlet side of the cooler.

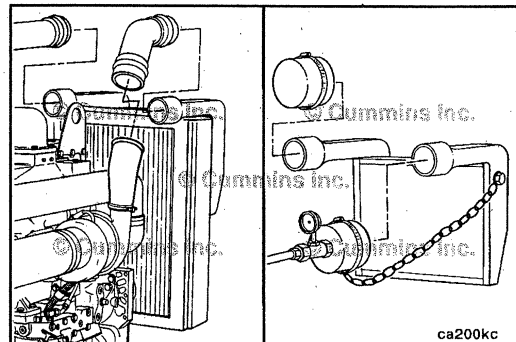

Apply air pressure to the cooler until the pressure gauge reads a steady 207 kPa [30 psi] of air pressure.

Shut off the airflow to the cooler, and start a stopwatch at the same time. Record the leakage at 15 seconds.

If the pressure drop is 34 kPa [5 psi] or less in 15 seconds, the cooler is functioning properly.

If the pressure drop is greater than 34 kPa [5 psi] in 15 seconds, check all connections again.

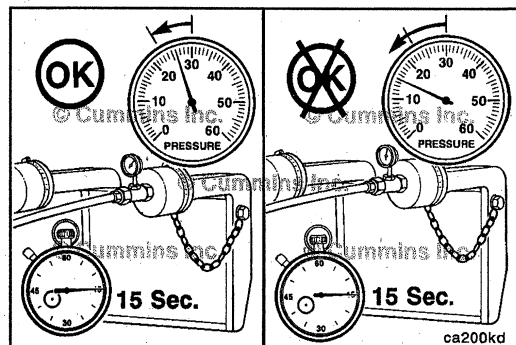

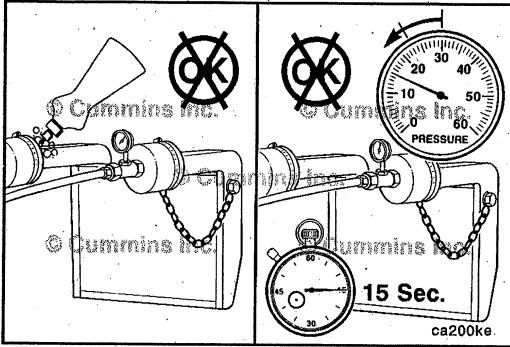

Determine if the pressure drop is caused by a leak in the charge air cooler or from a leaky connection. Use a spray bottle filled with soapy water applied to all hose connections, and watch for bubbles to appear at the location of the leak.

If the pressure drop is caused by a leaky connection, repair the connection, and repeat the test. If the leak is within the charge air cooler, repeat the test to verify the accuracy of the pressure drop measurement. Similar pressure drop readings **must** be obtained at least three consecutive tests before the reading can be considered accurate.

NOTE: If a charge air cooler leaks more than 34 kPa [5 psi] in 15 seconds, it will appear as a major leak in a leak tank.

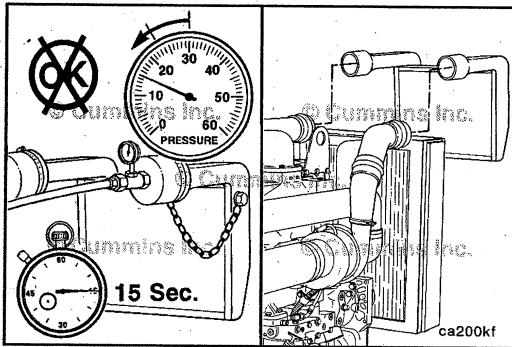

If the pressure drop is greater than 34 kPa [5 psi] in 15 seconds, the charge air cooler **must** be replaced.

Refer to the manufacturer's repair manual for replacement instructions.

NOTE: Charge air coolers are **not** designed to be 100-percent leak free. If the pressure drop is less than 34 kPa [5 psi] in 15 seconds, then the charge air cooler does **not** need to be replaced.

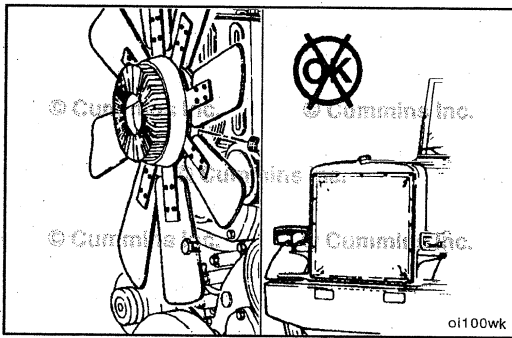

Temperature Differential Test

Inspect the charge air cooler fins for obstructions to airflow. Remove obstructions such as a winterfront or debris. Manually lock shutters in the open position if equipped.

Lock the fan drive in the ON mode to prevent erratic test results. This can be done by installing a jumper wire across the temperature switch.

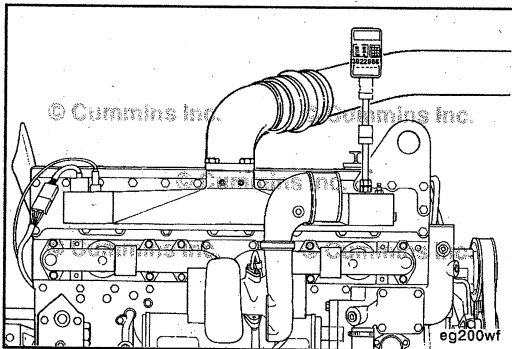

Install Fluke digital thermometer, Part No. 3822666, and thermocouple wire kit, Part No. 3822988, into the intake manifold at the 1/8-inch NPT tap near the air horn connection with the intake manifold.

Install another thermocouple at the air cleaner inlet to measure ambient air temperature.

QSB Series
Section A - Adjustment, Repair, and Replacement

Perform a road test with the engine at peak power and a vehicle speed of 48 kph [30 mph] or greater.

Record the intake manifold temperature and the ambient air temperature.

Calculate the differential temperature:

Intake Manifold Temperature	-	Ambient Air Temperature	=	Differential Temperature
Maximum Differential Temperature: 28°C [50°F]				

If the temperature differential is greater than the specifications, check the charge air cooler for dirt and debris on the fins and clean as necessary. If the problem still exists, check the charge air cooler for debris in the fins or between the charge air cooler and radiator. Confirm full fan engagement.

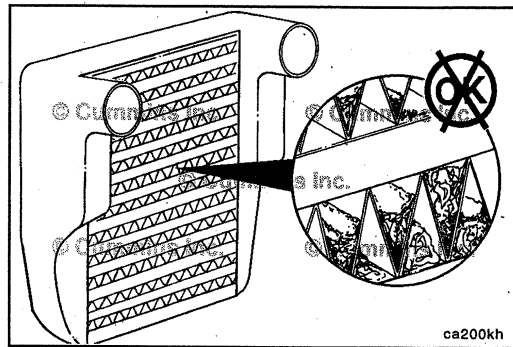
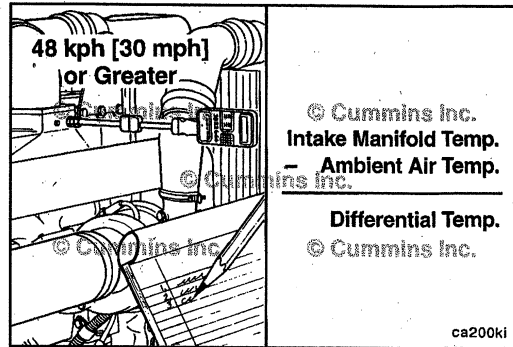

Pressure Differential Test

Preferred Method

Measure the charge air cooler system pressure drop with a mercury manometer, Part No. ST -1111-3.



Install one end of a mercury manometer to the fitting in the turbocharger compressor outlet elbow.
 Install the other end of the mercury manometer to the intake manifold.

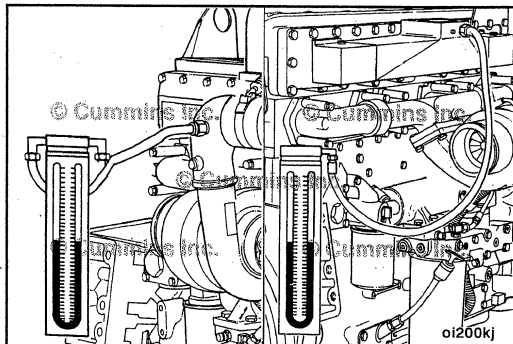
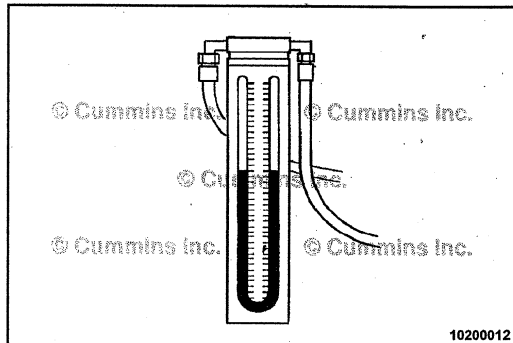

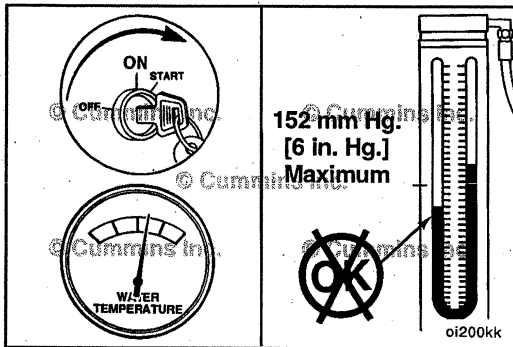

Operate the engine at rated rpm and load. Record the readings on the manometer.



If the differential pressure is greater than 152 mm Hg [6 in Hg], check the charge air cooler and associated piping for plugging. Clean or replace if necessary.

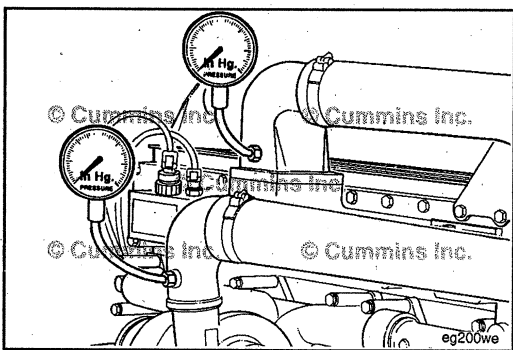

Optional Method

Obtain two (2) pressure gauges, Part No. ST-1273. Check both gauges on the same pressure source at 206 kPa [30 psi] for consistency.

Install pressure gauge, Part No. ST-1273, to the 1/8-inch fitting in the turbocharger compressor outlet elbow.

Install the other pressure gauge in the intake manifold.

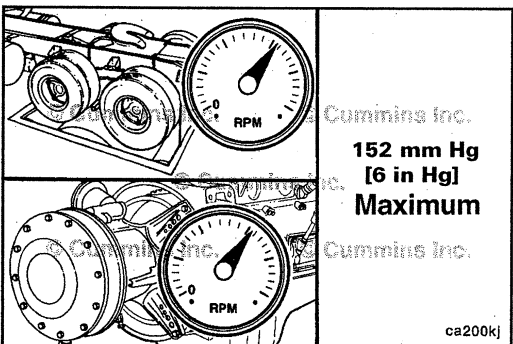

Operate the engine at rated rpm and load. Record the readings on the two gauges.



If the differential pressure is greater than 152 mm Hg [6 in Hg], check the charge air cooler and associated piping for plugging, restrictions, or damage.

Clean or replace if necessary.

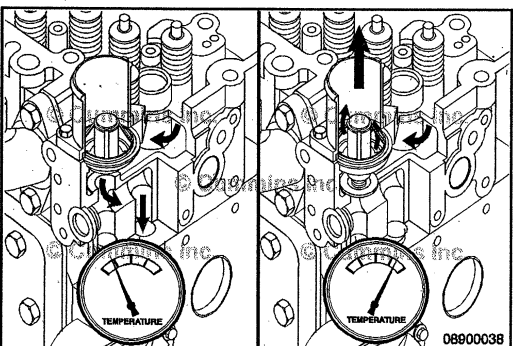

**Coolant Thermostat
General Information**

The thermostat controls the engine coolant temperature. When the coolant temperature is below the operating range, engine coolant is bypassed back to the inlet of the water pump. When the engine coolant temperature reaches the operating range, the thermostat opens, sealing off the bypass, forcing engine coolant to flow to the radiator or heat exchanger.

An incorrect or malfunctioning thermostat can cause the engine to run too hot or too cold.

⚠CAUTION⚠

Never operate the engine without a thermostat. Without a thermostat, the path of least resistance for the coolant is through the bypass to the water pump inlet. This can cause the engine to overheat.

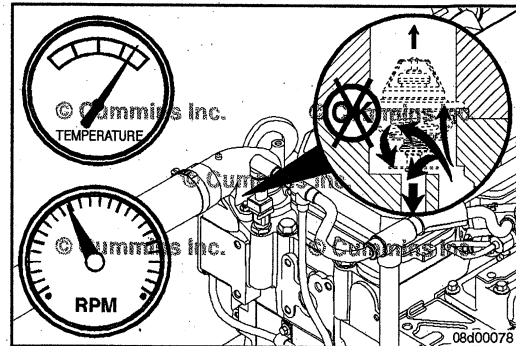

⚠CAUTION⚠

A missing check ball can cause the engine to run cold, resulting in engine damage.

The thermostat contains two check balls to vent air past the thermostat when it is closed. This is needed for the cooling system to fill.

NOTE: Some off-highway applications use a thermostat with one check ball. When servicing a thermostat always be sure to replace with the same part number. Though an incorrect thermostat will physically fit, it will lead to improper engine operation.

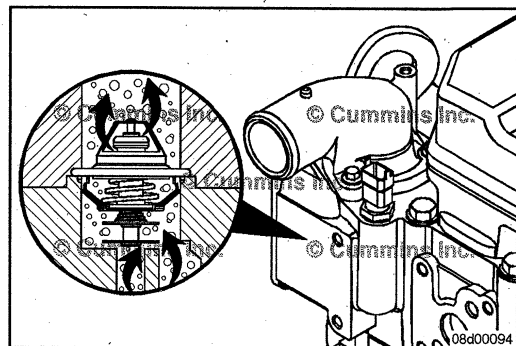

Preparatory Steps

⚠WARNING⚠

Batteries can emit explosive gases. To reduce the possibility of personal injury, always ventilate the compartment before servicing the batteries. To reduce the possibility of arcing, remove the negative (-) battery cable first and attach the negative (-) battery cable last.

Disconnect the batteries.

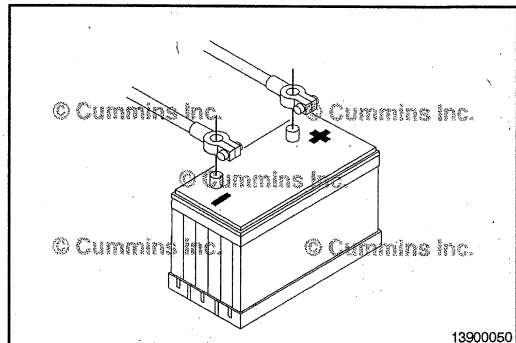

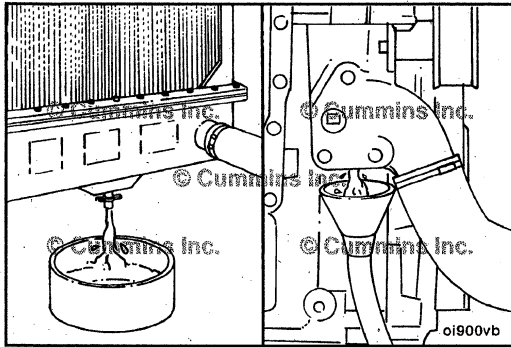

WARNING

Coolant is toxic. Keep away from children and pets. If not reused, dispose of in accordance with local environmental regulations.

WARNING

Do not remove the pressure cap from a hot engine. Wait until the coolant temperature is below 50°C [120°F] before removing the pressure cap. Heated coolant spray or steam can cause personal injury.

CAUTION

Use caution when draining coolant that coolant is not spilled or drained into the bilge area. Do not pump the coolant overboard. If the coolant is not reused, it must be discarded in accordance with local environmental regulations.

Drain the coolant below the level of the thermostat. Refer to Procedure 008-018.

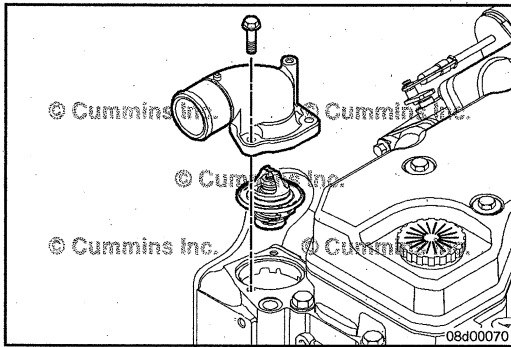

Remove

- Remove the water outlet connection capscrews.
- Remove the water outlet connection.
- Remove the thermostat.

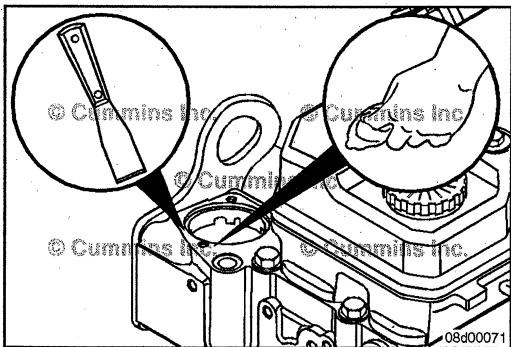

Clean and Inspect for Reuse

CAUTION

Do not let any debris fall into the thermostat cavity when cleaning the gasket surfaces. Damage to the cooling system and engine can occur.

Clean the mating surfaces with a gasket scraper and a clean cloth.

QSB Series
Section A - Adjustment, Repair, and Replacement

Inspect the thermostat for cracks, tears, damage, missing soft seat.



Remove and discard the gasket.

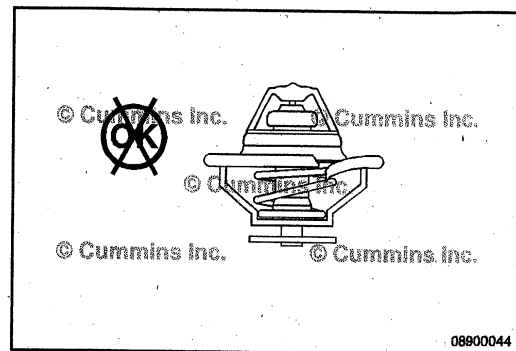

NOTE: Do **not** allow the thermostat or thermometer to touch the container.

Suspend the thermostat and a 100°C [212°F] thermometer in a container of water.

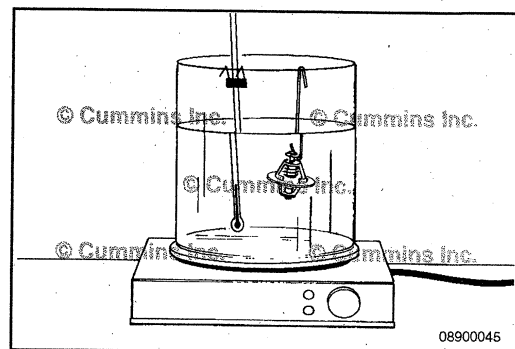

Heat the water and check the thermostat as follows:

The nominal operating temperature is stamped on the thermostat. The thermostat **must** meet the following criteria:

- It **must** begin to open within 1°C [2°F] of nominal temperature.
- It **must** be fully open within 12°C [22°F] of nominal temperature.

Thermostat Opening Temperatures - Automotive Applications

	°C		°F
Initial Opening Temperature	81	MIN	178
Fully Opened Temperature	94	MAX	202

Thermostat Opening Temperatures - Industrial Engines

	°C		°F
Initial Opening Temperature	87	MIN	188
Fully Opened Temperature	96	MAX	205

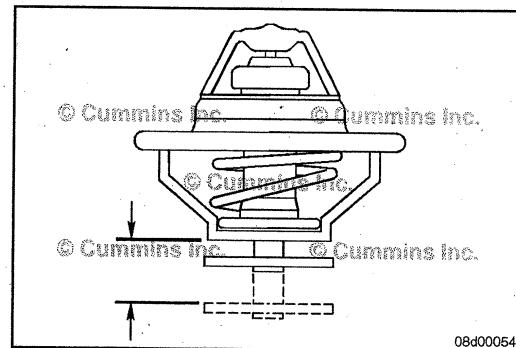

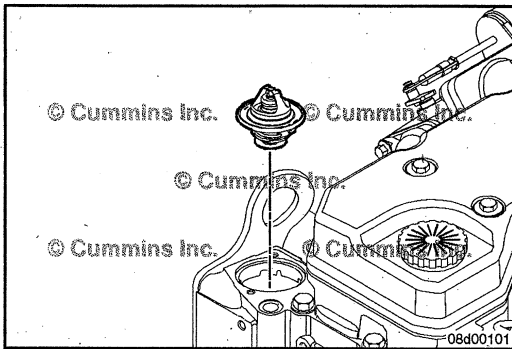

Install

⚠ CAUTION ⚠

Always use the correct thermostat and do not operate the engine without a thermostat installed. The engine can overheat if operated without a thermostat because the path of least resistance for the coolant is through the bypass to the pump inlet. An incorrect thermostat can cause the engine to overheat or run too cold.

Install the thermostat into the thermostat housing.

NOTE: Make sure a new thermostat seal is installed on the outer lip of the thermostat flange every time the thermostat is reinstalled.

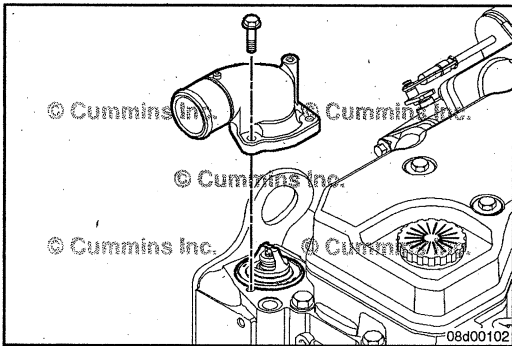

Install the water outlet connection and mounting capscrews.

Tighten the capscrews.



Torque Value: 10 N•m [89 in-lb]

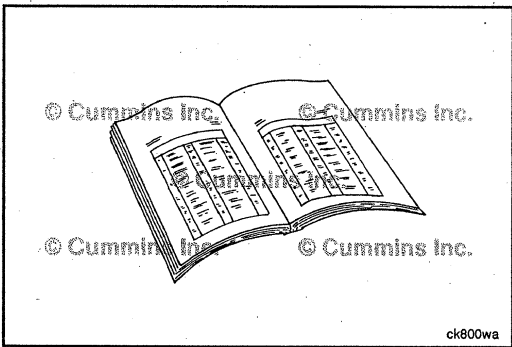

Finishing Steps

⚠ CAUTION ⚠

Always vent the engine during filling to remove air from the coolant system, or overheating can result.

Fill the cooling system. Refer to Procedure 008-018.

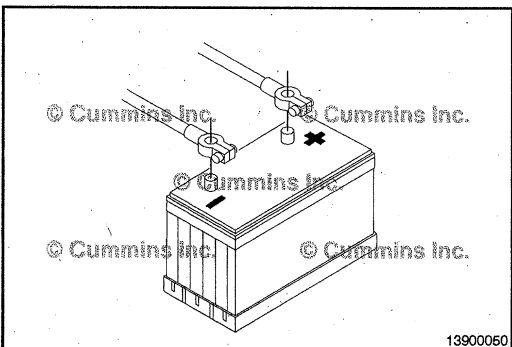

⚠ WARNING ⚠

Batteries can emit explosive gases. To reduce the possibility of personal injury, always ventilate the compartment before servicing the batteries. To reduce the possibility of arcing, remove the negative (-) battery cable first and attach the negative (-) battery cable last.

Connect the batteries.

QSB Series
Section A - Adjustment, Repair, and Replacement

Operate the engine and check for leaks.

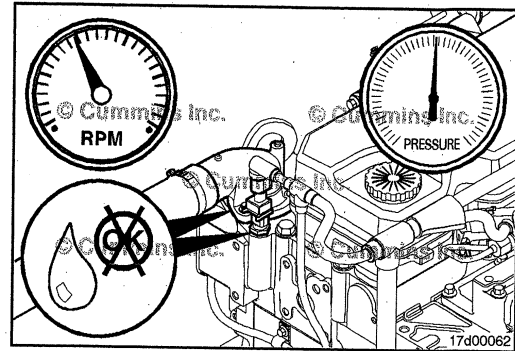

Cooling Fan Belt Tensioner
Maintenance Check

With the engine stopped, check the tensioner arm, pulley and stops for cracks. If any cracks are noticed, the tensioner **must** be replaced.

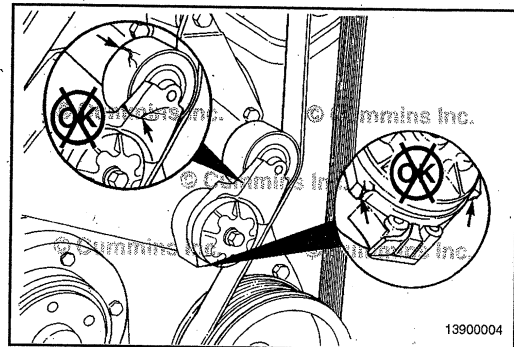

With the belt installed, verify that neither tensioner arm stops is in contact with the spring casing stop. If either of the stops is touching:

- Verify the correct belt part number is installed.
- If the correct belt is installed, replace the belt. Refer to Procedure 008-002, Drive Belt, Cooling Fan, in Section A.

After replacing the belt, if the tensioner arm stops are still in contact with the spring case stop, replace the tensioner.

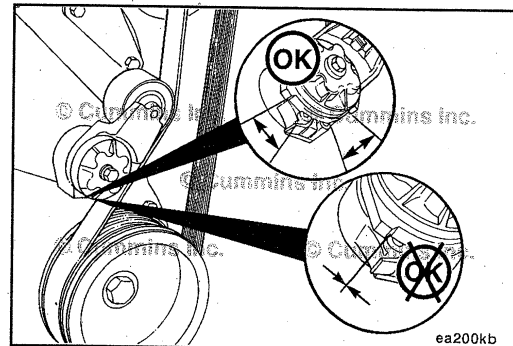

Check the location of the drive belt on the belt tensioner pulley. The belt should be centered on, or close to the middle of, the pulley. Misaligned belts, either too far forward or backward, can cause belt wear, belt roll-off failures, or increase uneven tensioner bushing wear.

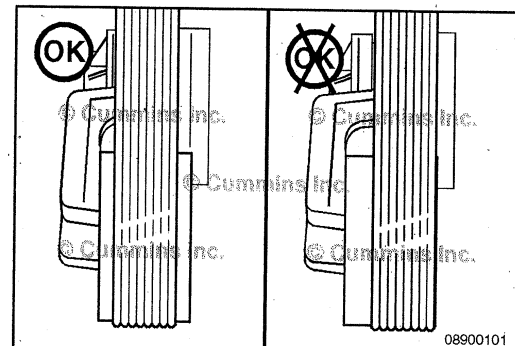

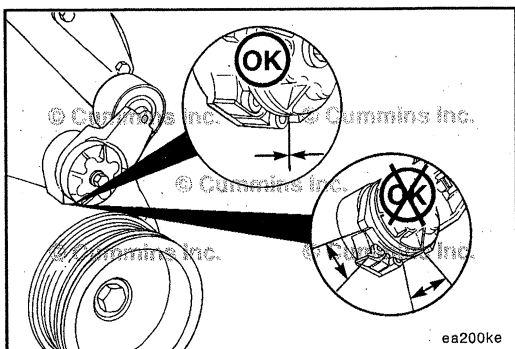

Remove the drive belt. Refer to Procedure 008-002, Drive Belt, Cooling Fan, in Section A.

With the belt removed, verify that the tensioner arm stop is in contact with the spring case stop. If they are not touching, the tensioner **must** be replaced.

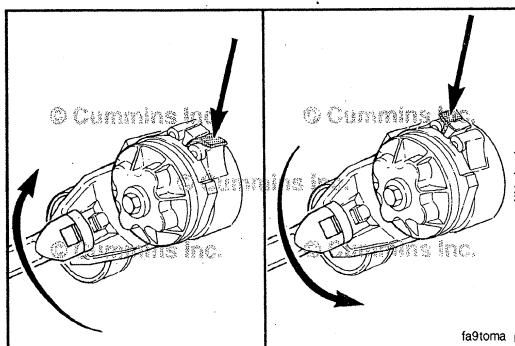

Drive Belt, Cooling Fan Remove



Lift the tensioner to remove the drive belt.

NOTE: The belt tensioner winds in the direction that the spring tang is bent over the tensioner body. To loosen the tension on the belt, rotate the tensioner to wind the spring tighter.

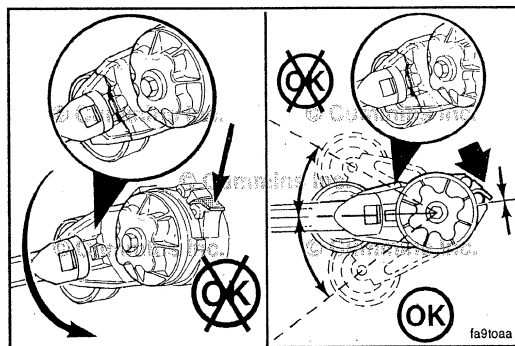

CAUTION

Applying excessive force in the opposite direction of windup or after the tensioner has been wound up to the positive stop can cause the tensioner arm to break.

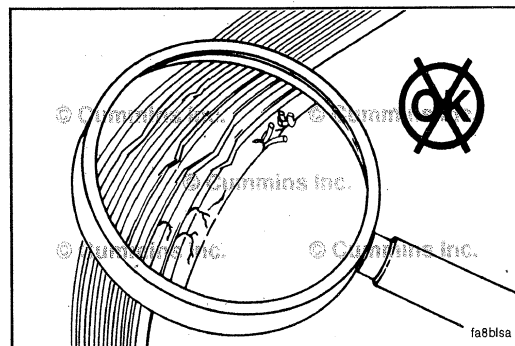

Inspect for Reuse

Inspect the drive belt for:

- Cracks
- Glazing
- Tears or cuts
- Hardening
- Excessive wear.

Install

⚠CAUTION⚠

The belt tensioner is spring-loaded and must be pivoted away from the drive belt. Pivoting in the wrong direction can result in damage to the belt tensioner.

Lift the tensioner to install the drive belt.

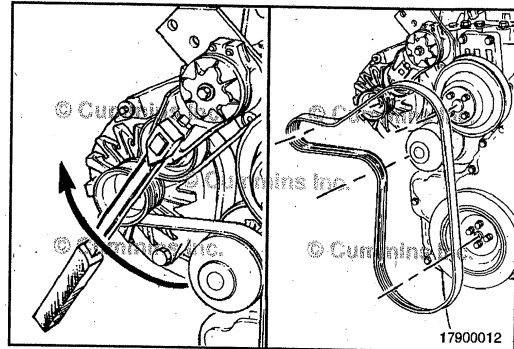

Fan Spacer and Pulley

Preparatory Steps

- Remove the drive belt.

NOTE: Loosen the capscrews before removing the belt, and tighten the capscrews after the belt is installed.

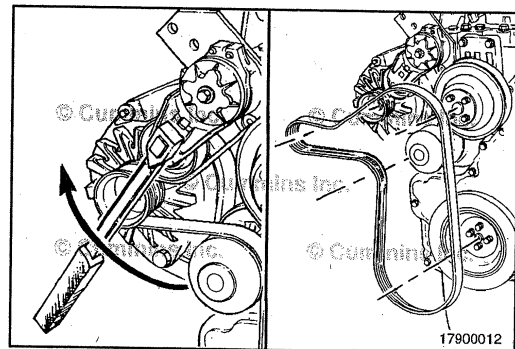

Remove

Remove the four capscrews, fan, and spacer.

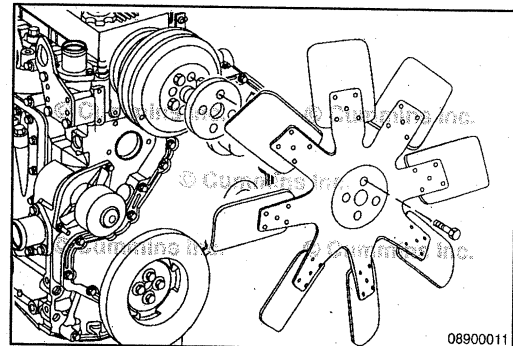

Inspect for Reuse

Inspect the fan pulley for cracks near bolt holes.

Check for cracks, loose rivets, and bent or loose blades.

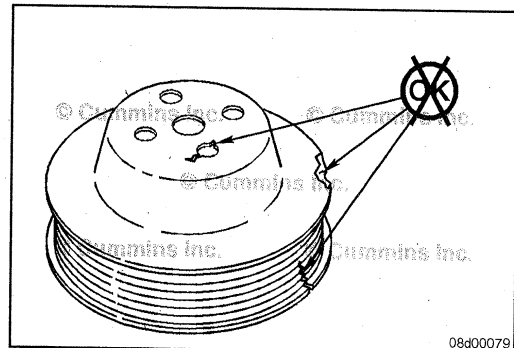

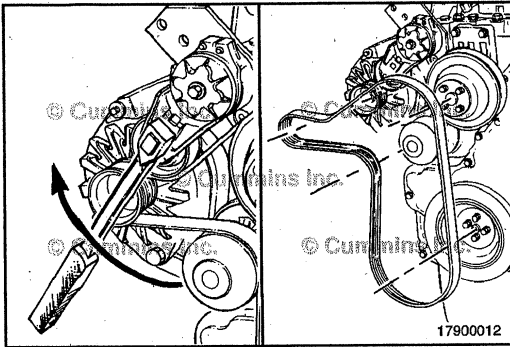

Install

3/8-Inch Square Drive



Lift the tensioner, and install the belt.

Service Tip: If difficulty is experienced installing the drive belt (the belt seems too short), position the belt over the grooved pulleys first; then, while holding the tensioner up, slide the belt over the water pump pulley.

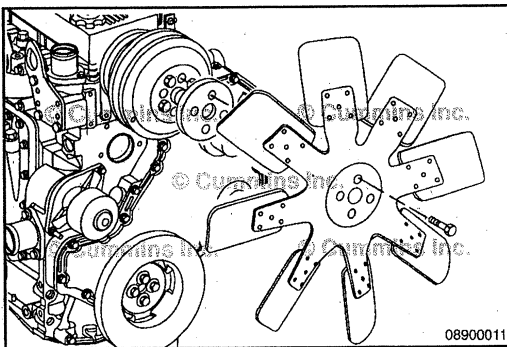

10 mm, 13 mm

Install the four capscrews, fan, and spacer.



10-mm Wrench

Torque Value: 24 N•m [212 in-lb]



13-mm Wrench

Torque Value: 43 N•m. [32 ft-lb]

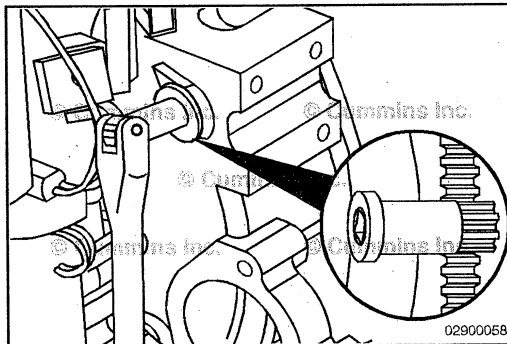

Starting Motor Rotation Check

If the starter solenoid is making a sound but the engine is **not** rotating, turn the keyswitch to the OFF position, and attempt to bar the crankshaft in both directions.

Bar the engine using the barring tool, Part Number 3824591.

If the crankshaft will bar over, attempt to start the engine. If the starter motor cranks the engine, check the starter motor pinion gear and flywheel ring gear for damage.

If damage to the starter motor pinion gear and/or flywheel ring gear is found when replacing the components, make sure to measure the distance from the starting motor mounting flange to the forward face of the front side of the flywheel ring gear. Follow the measure step of this procedure.

QSB Series
Section A - Adjustment, Repair, and Replacement

If the crankshaft does **not** rotate or requires more than the normal effort to bar, check for an internal malfunction or a problem with the drive unit and/or accessories.

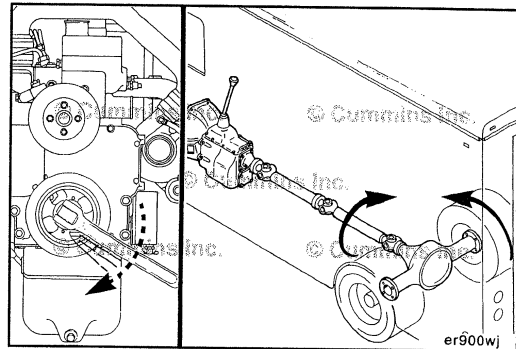

If the engine cranking speed is too slow/will **not** crank at all and the engine rotates freely:

Make sure the wiring connections are clean, tight and **not** damaged.

Check the battery voltage. Refer to the OEM service manual and/or manufacturer for specifications.

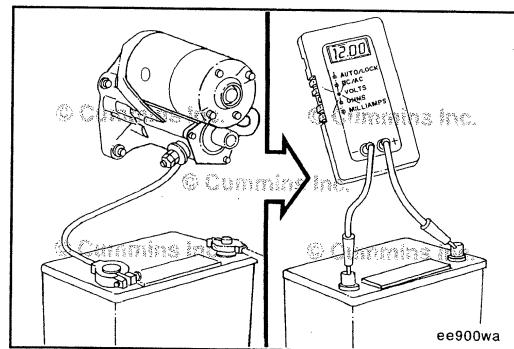

Check the voltage at the starting motor during cranking. If the voltage drops more than 2.4 VDC on a 12-VDC system and 4.8 VDC on a 24-VDC system, check that all connections are clean and tight.

If the cables are correct and the voltage drop exceeds the limit, replace the starting motor.

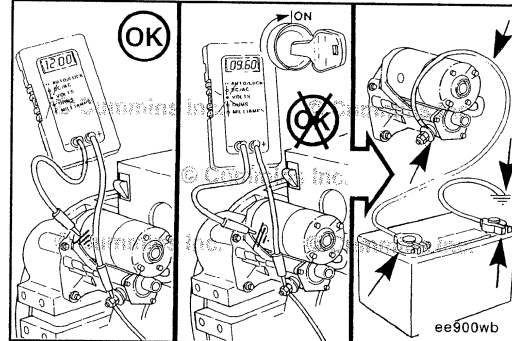

Remove

⚠ WARNING ⚠

Batteries can emit explosive gases. To reduce the possibility of personal injury, always ventilate the compartment before servicing the batteries. To reduce the possibility of arcing, remove the negative (-) battery cable first and attach the negative (-) battery cable last.

Disconnect the ground cable from the battery terminal.

Identify each wire with a tag indicating location on starting motor.

Remove the electrical connections from the starting motor.

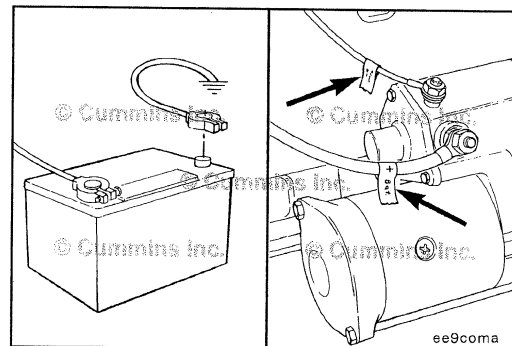

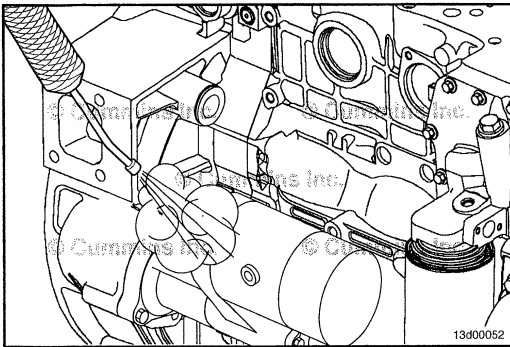

▲ WARNING ▲

When using a steam cleaner, wear safety glasses or a face shield, as well as protective clothing. Hot steam can cause serious personal injury.

▲ WARNING ▲

Wear appropriate eye and face protection when using compressed air. Flying debris and dirt can cause personal injury.

Prior to removing the starter, use steam to clean the area around the starting motor to prevent debris from entering the flywheel housing.

Dry with compressed air.

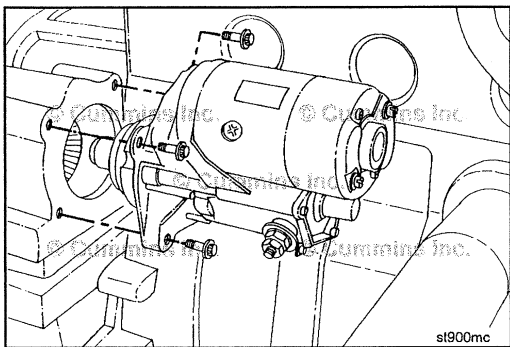

Remove the three capscrews and the starting motor.

NOTE: If equipped with a starting motor spacer, remove the spacer and clean all surfaces between the starting motor, starting motor spacer, and flywheel housing with a wire brush.

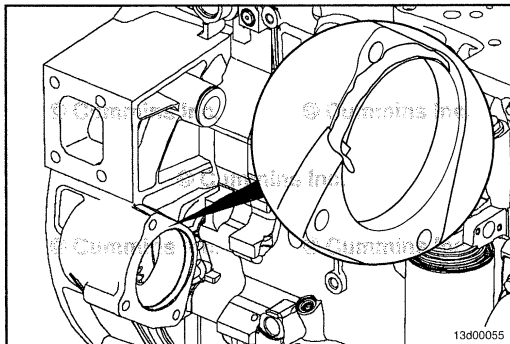

Clean and Inspect for Reuse

For engines that use wet flywheel housings, clean any left over sealant from the starting motor mounting flange on both the flywheel housing and starting motor. Make sure these surfaces are clean of oil and debris.

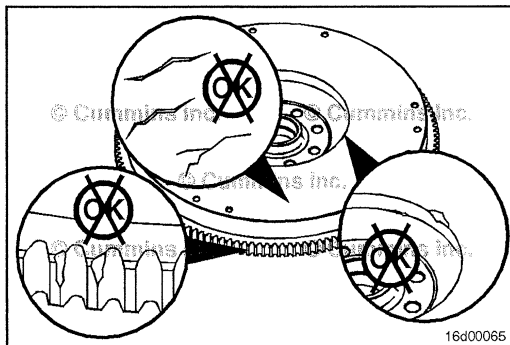

Inspect the starter motor pinion gear and/or flywheel ring gear for chipping or uneven wear.

NOTE: If the starter motor pinion gear and/or flywheel ring gear teeth are damaged, they **must** be replaced.

Refer to a Cummins Authorized Repair Facility.

Measure

Using an inside micrometer or a vernier caliper, measure the distance from the starting motor mounting flange to the forward face of the front side of the flywheel ring gear.

NOTE: Include any spacers previously removed when completing the measurement.

Starting Motor Spacing		
mm		in
49.28	MIN	1.94
52.32	MAX	2.06

Add or remove spacers as necessary to achieve the correct starting motor spacing.

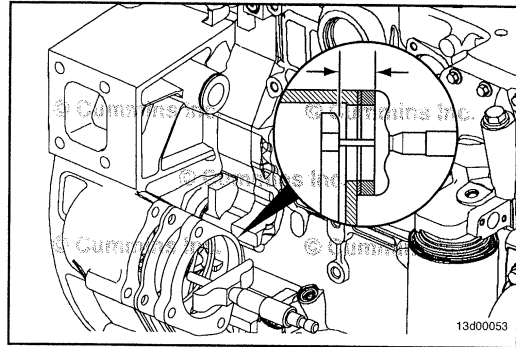

Install

For engines with wet flywheel housings, apply a 1.5 to 2.0 mm [0.06 to 0.09 in] wide bead of sealant, Part Number 3164067 to the flywheel housing starting motor mounting flange.

NOTE: If a starting motor spacer is required, make to apply sealant to the side of the spacer that contacts the starting motor.

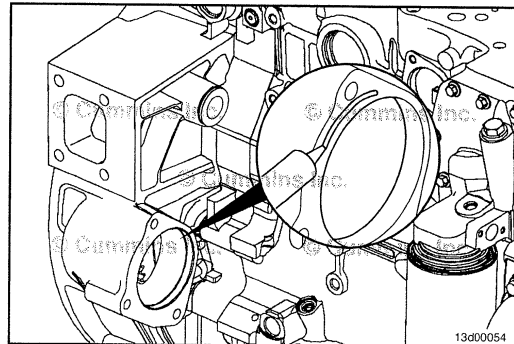

Install the three capscrews, the starting motor, and starting motor spacer (if required).

Torque Value: 43 N•m [32 ft-lb]

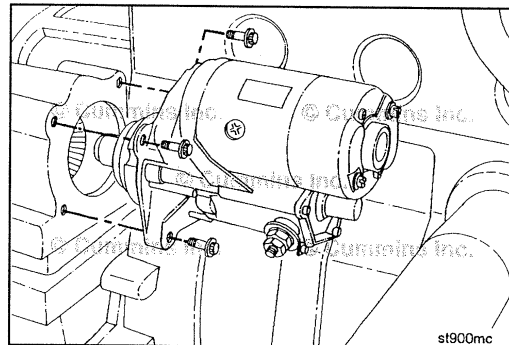

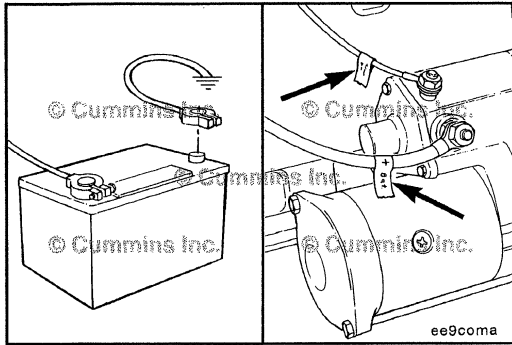

Cummins Branded Starters

⚠ CAUTION ⚠

Do not overtighten the electrical connections. Starter damage can result.



NOTE: Use the location tags to help identify where each wire connection goes.

Connect the electrical connections to the starter motor.

Torque Value:

M5 4 N•m [35 in-lb]
M10 21 N•m [185 in-lb]

⚠ WARNING ⚠

Batteries can emit explosive gases. To reduce the possibility of personal injury, always ventilate the compartment before servicing the batteries. To reduce the possibility of arcing, remove the negative (-) battery cable first and attach the negative (-) battery cable last.

Connect the ground cable to the battery terminal.

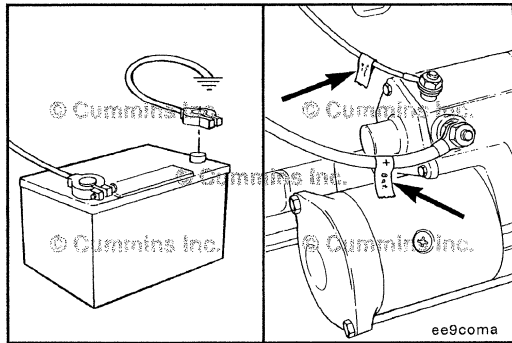

Non-Cummins Branded Starters

⚠ CAUTION ⚠

Do not overtighten the electrical connections. Starter damage can result.



NOTE: Use the location tags to help identify where each wire connection goes.

Install the starter motor electrical connections.

For Non-Cummins branded starters, refer to the Original Equipment Manufacturer (OEM) manual for torque specifications.

⚠ WARNING ⚠

Batteries can emit explosive gases. To reduce the possibility of personal injury, always ventilate the compartment before servicing the batteries. To reduce the possibility of arcing, remove the negative (-) battery cable first and attach the negative (-) battery cable last.

Connect the ground cable to the battery terminal.

Section D - System Diagrams

Section Contents

	Page
Flow Diagram, Air Intake System	D-10
Flow Diagram.....	D-10
Flow Diagram, Compressed Air System	D-14
Flow Diagram.....	D-14
Flow Diagram, Cooling System	D-9
Flow Diagram.....	D-9
Flow Diagram, Exhaust System	D-11
Flow Diagram.....	D-11
Without EGR.....	D-11
With EGR.....	D-12
Marine Applications.....	D-13
Flow Diagram, Fuel System	D-2
Flow Diagram.....	D-2
With Electric Lift Pump.....	D-3
Flow Diagram, Lubricating Oil System	D-4
Flow Diagram.....	D-4
System Diagrams - Overview	D-1
General Information.....	D-1



This Page Left Intentionally Blank

System Diagrams - Overview

General Information

The following drawings show the flow through the engine systems. Although parts can change between different applications and installations, the flow remains the same. The systems shown are:

- Fuel System
- Lubricating Oil System
- Coolant System
- Intake Air System
- Exhaust System
- Compressed Air System.

Knowledge of the engine systems can help you in troubleshooting, service, and general maintenance of your engine.



Flow Diagram, Fuel System

Flow Diagram

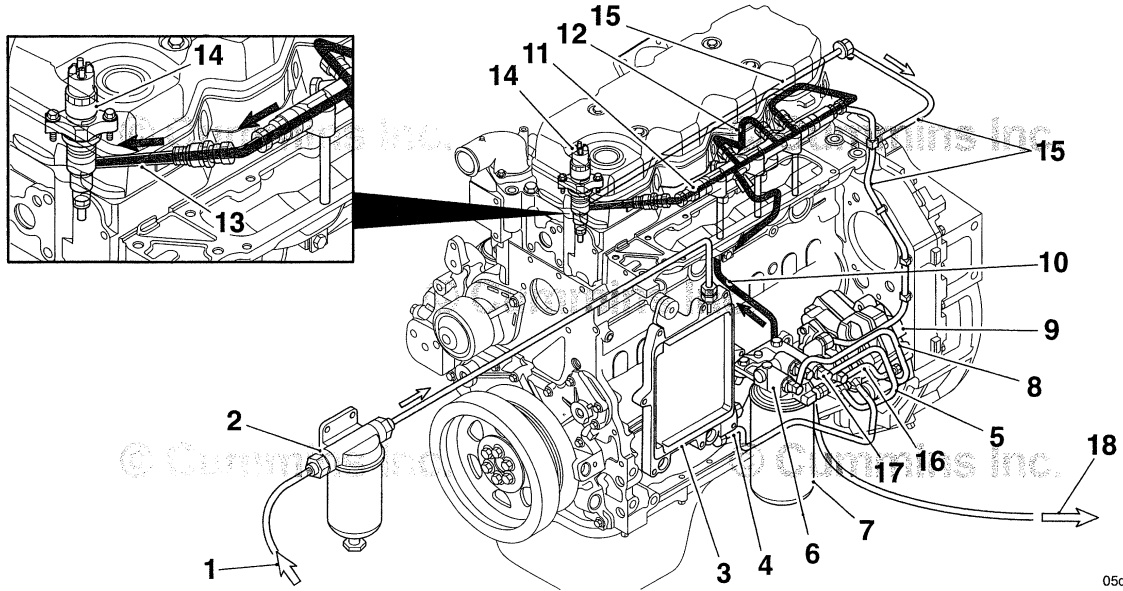

05d00888

1. From fuel supply tank
2. Water/fuel separator (**not** mounted on engine)
3. ECM cooling plate *
4. To fuel gear pump
5. To fuel filter
6. Fuel filter head
7. Fuel filter
8. To high-pressure pump
9. High-pressure pump
10. To fuel rail
11. Fuel rail
12. To injectors
13. High-pressure connector
14. Injector
15. Fuel return from injectors and fuel rail to fuel filter head
16. Fuel return from high-pressure pump to fuel filter head
17. Fuel return manifold
18. To fuel supply tank.

NOTE: * Engines are either equipped with an air cooled or fuel cooled ECM. If an air cooled ECM is used, the fuel enters the engine from the OEM connection at the gear pump inlet.

With Electric Lift Pump

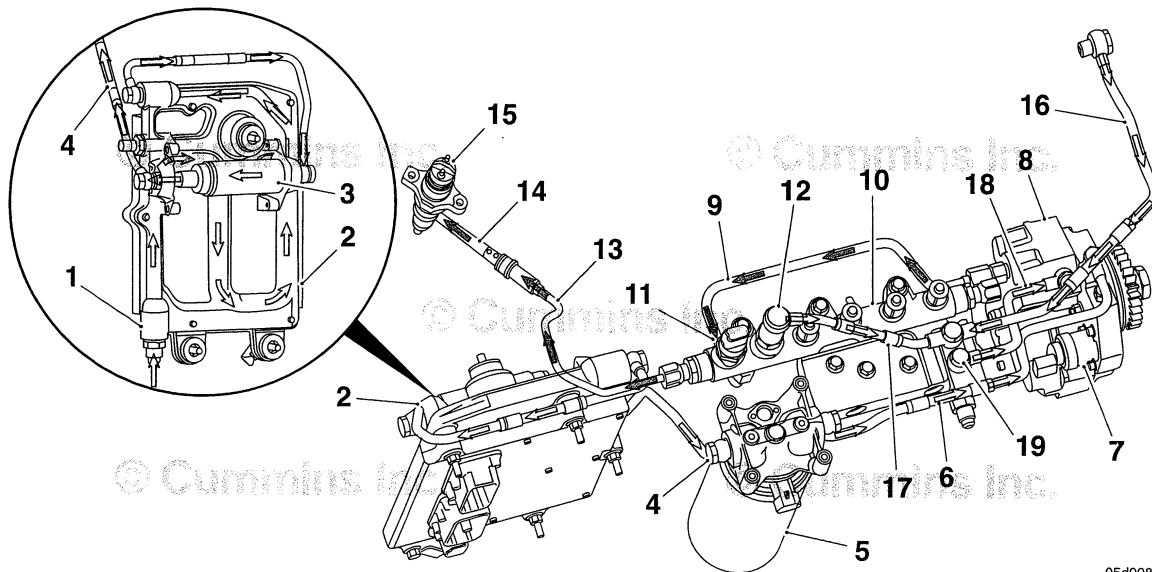

- 1. Fuel inlet - ECM cooling plate
- 2. ECM cooling plate
- 3. Lift pump
- 4. Fuel line (from lift pump to fuel filter)
- 5. Fuel filter
- 6. Fuel pump inlet to gear pump
- 7. EFC actuator
- 8. Fuel pump
- 9. High-pressure fuel line (fuel pump to rail)
- 10. Fuel rail
- 11. Fuel rail pressure sensor
- 12. Fuel pressure relief valve
- 13. High-pressure fuel line (fuel rail to fuel injector)
- 14. High-pressure connector to fuel injector
- 15. Fuel injector
- 16. Injector return line
- 17. Pressure relief return line
- 18. Fuel pump return line
- 19. Fuel return manifold.

05d00889

Flow Diagram, Lubricating Oil System

Flow Diagram

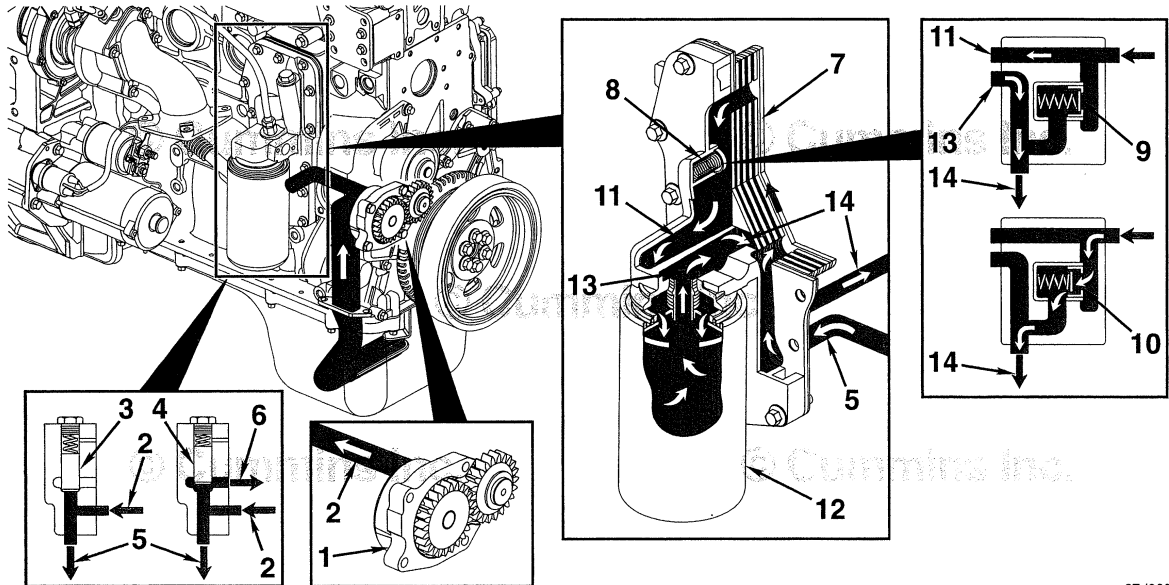

1. Gerotor lubricating oil pump
2. From lubricating oil pump
3. Pressure regulating valve closed
4. Pressure regulating valve open
5. To lubricating oil cooler
6. To lubricating oil pan
7. Lubricating oil cooler
8. Filter bypass valve
9. Filter bypass valve closed
10. Filter bypass valve open
11. To lubricating oil filter
12. Full-flow lubricating oil filter
13. From lubricating oil filter
14. Main lubricating oil rifle.

07d00073

Flow Diagram, Lubricating Oil System

Flow Diagram

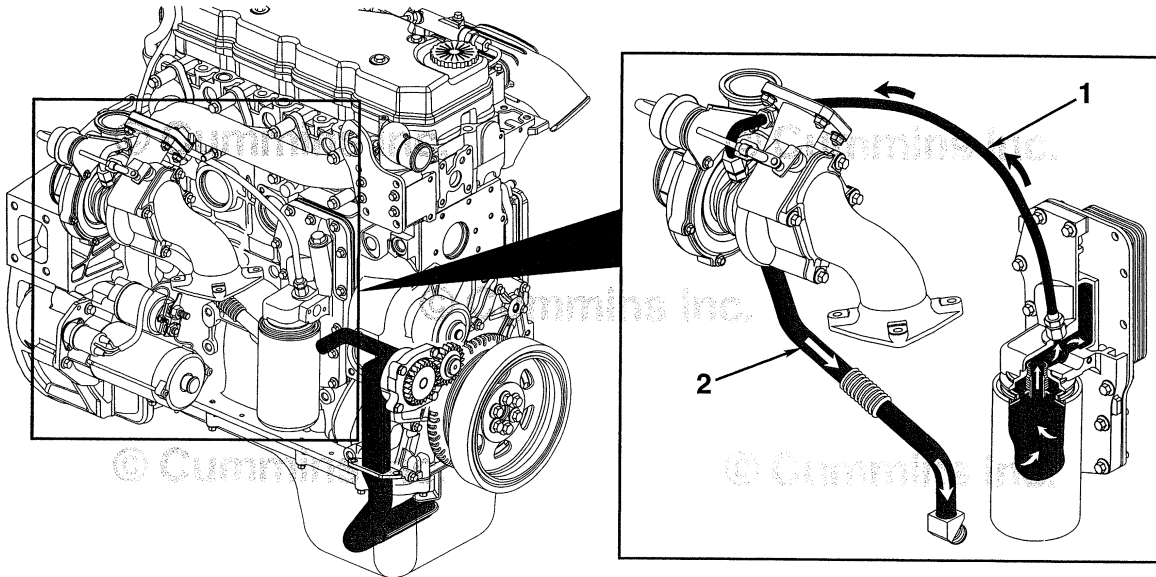

07d00074

Lubrication for the Turbocharger

1. Turbocharger lubricating oil supply
2. Turbocharger lubricating oil drain.



Flow Diagram, Lubricating Oil System

Flow Diagram

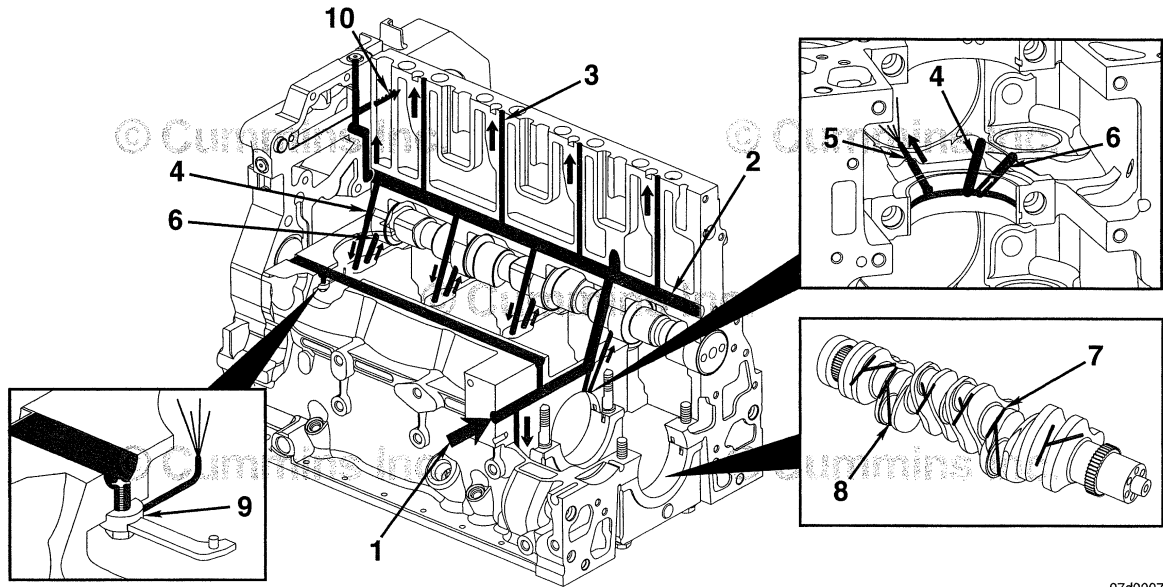

07d00075

Lubrication for the Power Components

1. From lubricating oil cooler
2. Main lubricating oil rifle
3. To valve train
4. From main lubricating oil rifle
5. To piston-cooling nozzle
6. To camshaft
7. Crankshaft main journal
8. Oil supply to rod bearings
9. Directed piston-cooling nozzle
10. To internal lubrication of air compressor.

Flow Diagram, Lubricating Oil System

Flow Diagram

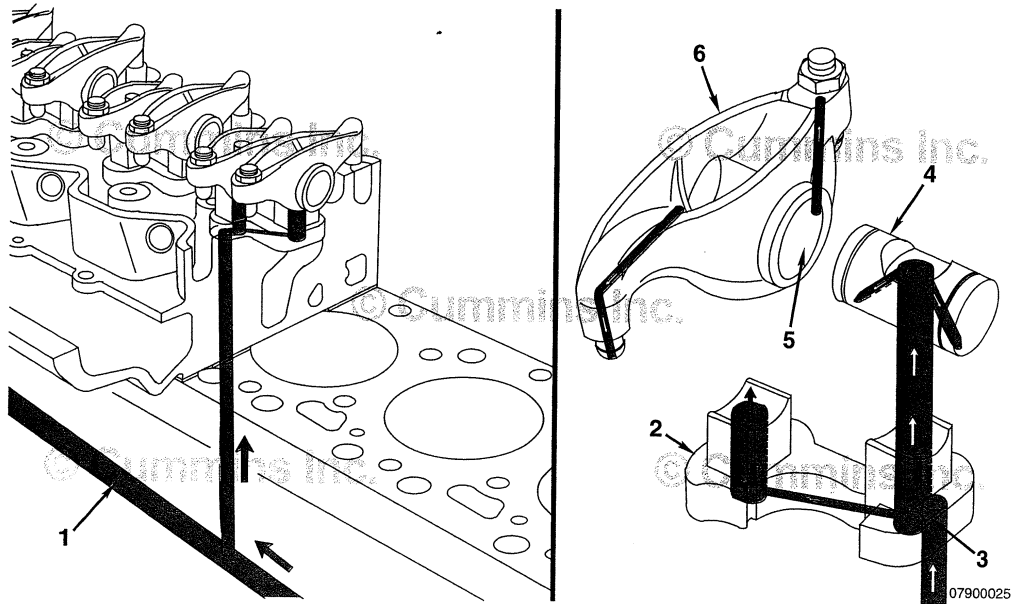

Lubrication for the Overhead Components

- 1. Main lubricating oil rifle
- 2. Rocker lever support
- 3. Transfer slot
- 4. Rocker lever shaft
- 5. Rocker lever bore
- 6. Rocker lever.



Flow Diagram, Lubricating Oil System

Flow Diagram

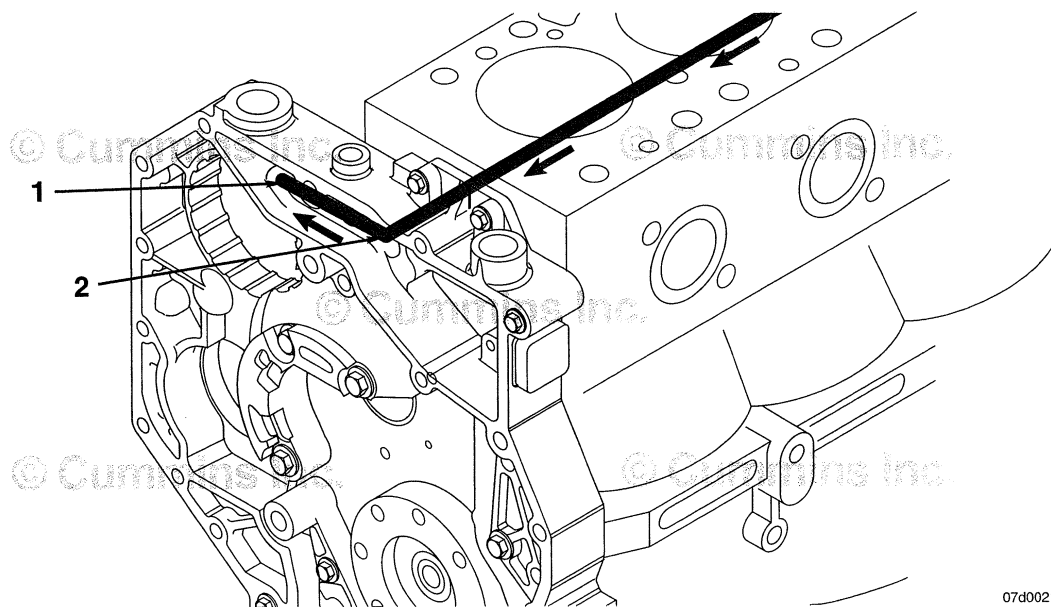

Lubrication for the Accessory Drive

07d00212

- 1. Oil feed from block
- 2. Oil supply to accessory drive

NOTE: Oil returns to pan through the gear housing

Flow Diagram, Cooling System

Flow Diagram

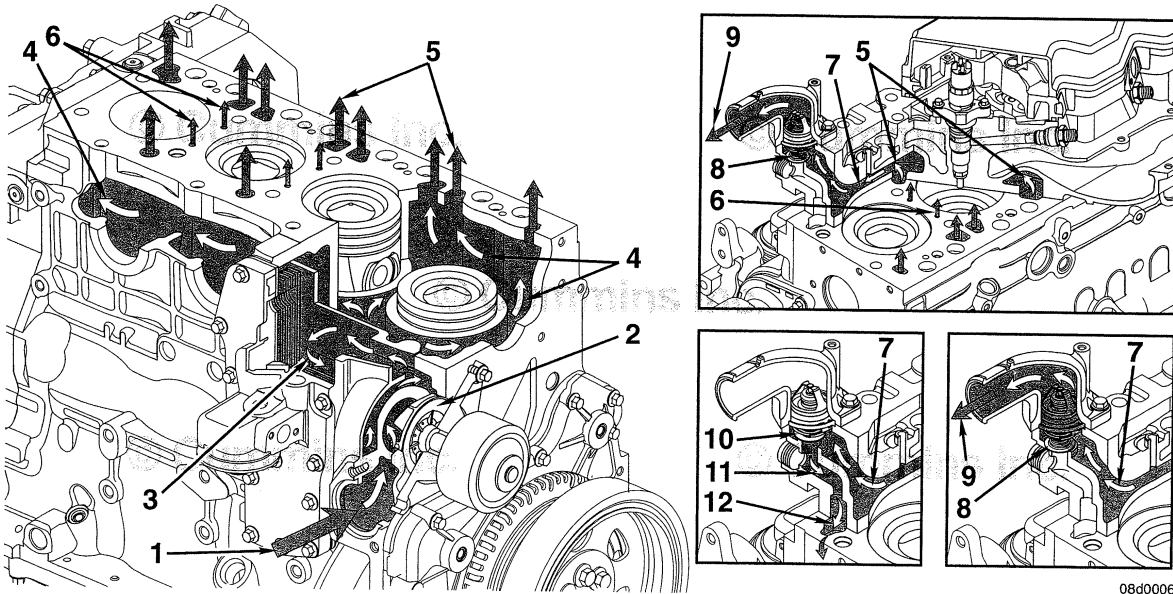

- 1. Coolant inlet
- 2. Pump impeller
- 3. Coolant flow past lubricating oil cooler
- 4. Coolant flow past cylinders
- 5. Coolant flow from cylinder block to cylinder head
- 6. Coolant flow between cylinders
- 7. Coolant flow to thermostat housing
- 8. Coolant bypass passage
- 9. Coolant flow back to radiator
- 10. Bypass open
- 11. Coolant bypass in cylinder head
- 12. Coolant flow to water pump inlet.



Flow Diagram, Air Intake System

Flow Diagram

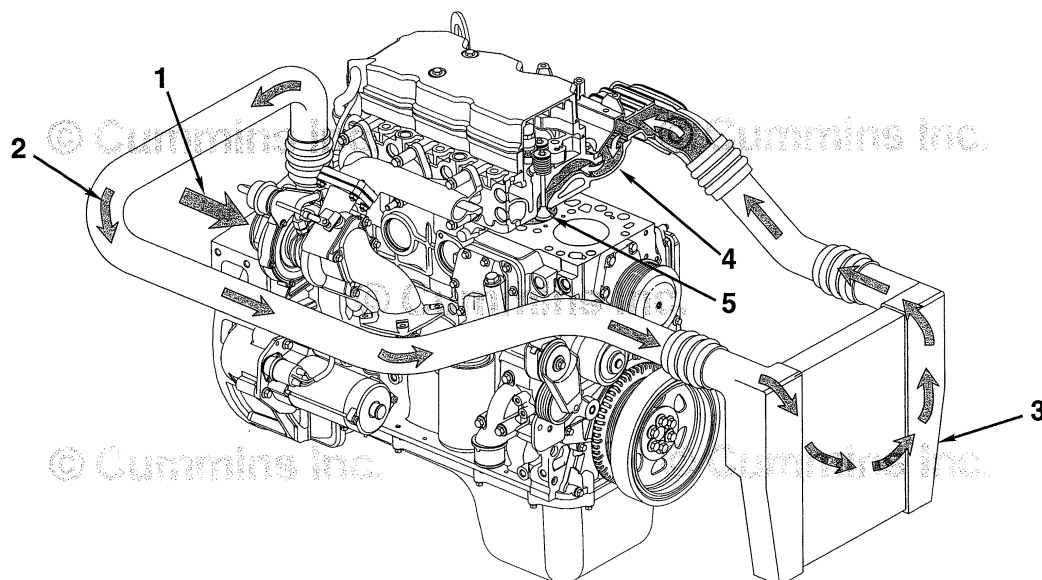

10d00022

1. Intake air inlet to turbocharger
2. Turbocharger air to charge air cooler
3. Charge air cooler
4. Intake manifold (integral part of the cylinder head)
5. Intake valve.

Flow Diagram, Exhaust System

Flow Diagram Without EGR

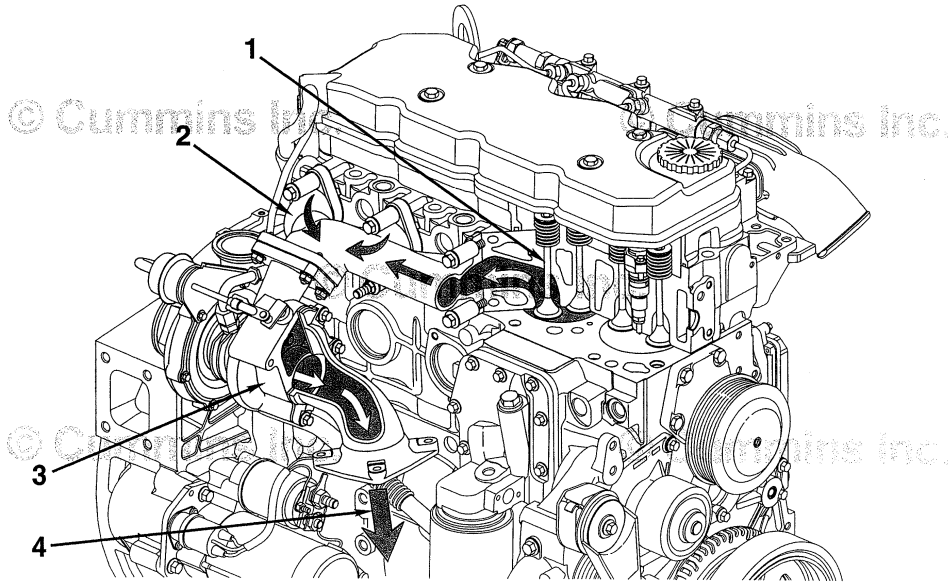

1. Exhaust valve
2. Exhaust manifold
3. Turbocharger
4. Turbocharger exhaust outlet.

11d00018



With EGR

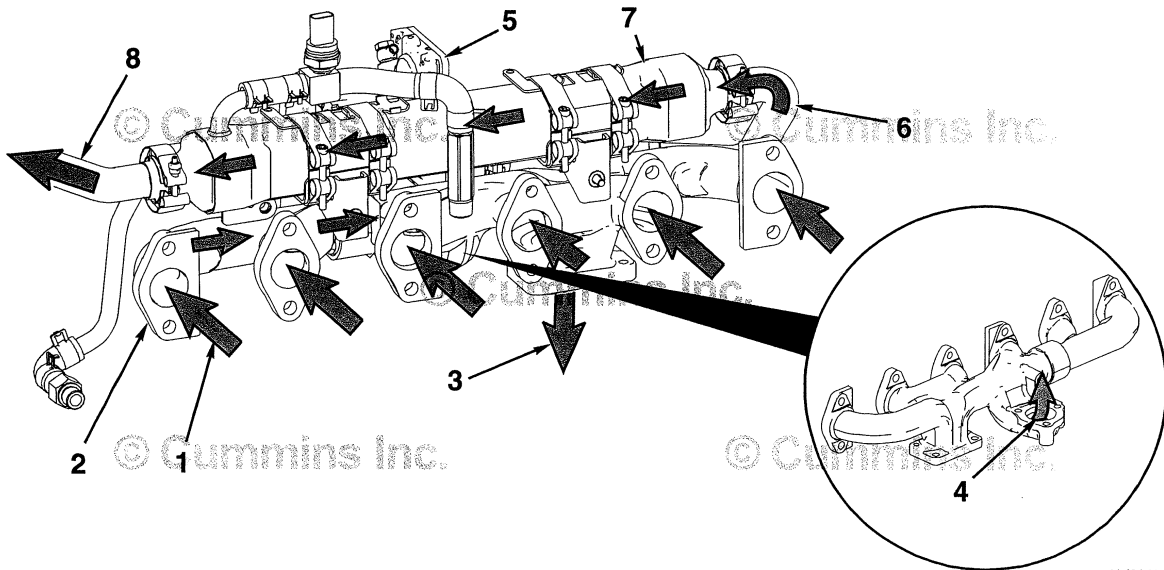

- 1. Exhaust gas to manifold
- 2. Exhaust manifold
- 3. Exhaust gas to turbocharger
- 4. Exhaust gas to EGR valve

- 5. EGR valve
- 6. Exhaust gas from EGR valve to EGR cooler connection
- 7. EGR cooler
- 8. Cooled exhaust gas to EGR connection tube and EGR mixer.

11d00077

Marine Applications

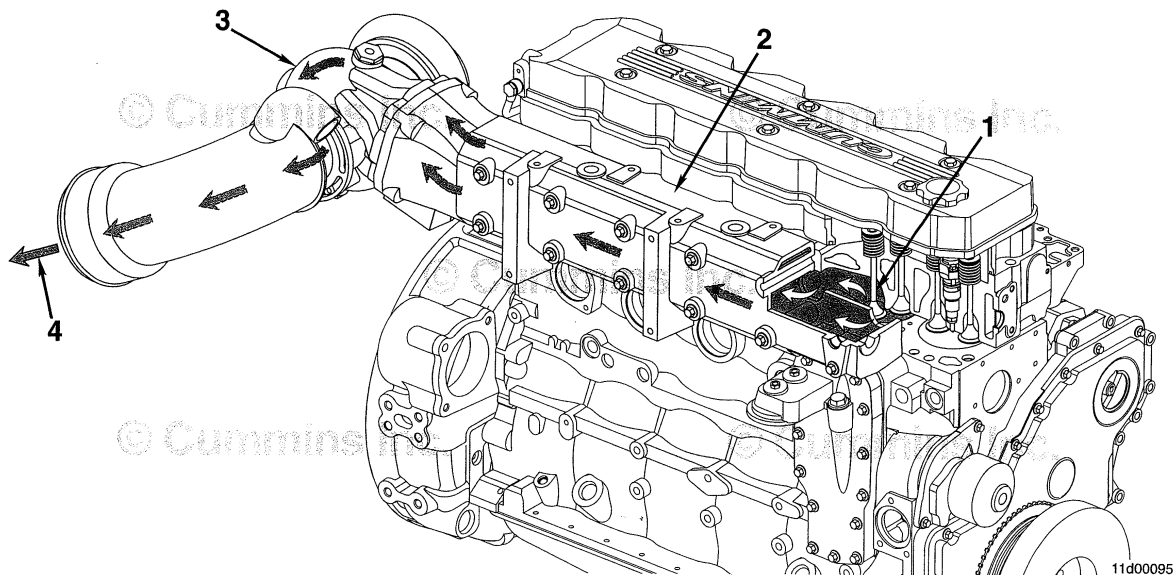

1. Exhaust valve
2. Exhaust manifold (wet)
3. Turbocharger (water cooled)
4. Exhaust outlet.



Flow Diagram, Compressed Air System

Flow Diagram

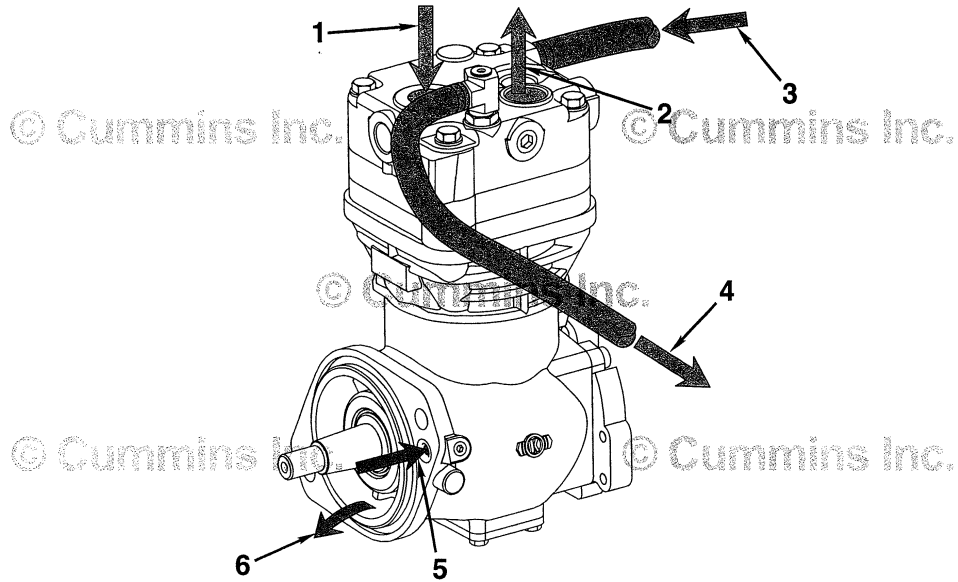

1. Air in
2. Air out
3. Coolant in
4. Coolant out
5. Lubricating oil in (internal to the gear housing)
6. Lubricating oil out (internal to the gear housing).

Cummins Service Publications Electronic Books on CD-ROM

Enclosed, we've included on CD-ROM, an electronic copy of this publication in Adobe® Acrobat® format (PDF) for your personal use and reference. **Before you begin to use the CD-ROM, please read the "Cummins Service Publications Electronic Books on CD-ROM Information" printed section, beginning on the next page.** This section includes information about this CD-ROM including System Requirements, Local Administrative Rights requirements, How to Use, Helpful Support Tips and other information.



Cummins Service Publications Electronic Books on CD-ROM Information

The enclosed CD-ROM provides you with the capability to view this publication electronically as well as perform searches. This CD-ROM is copy protected and will not allow Printing, Changing of Content, Extracting Content or Commenting / Annotating of the PDF file.

This CD-ROM is read only, and you will not be able to copy files from the CD-ROM and have them open or function in any manner. The only method to view the electronic publication is from the original CD-ROM.

This CD-ROM is intended for use by the owner of the printed publication only. Copying or distribution of content from this CD-ROM is expressly prohibited. This CD-ROM will not function from a network server CD-ROM drive. It will function only in a CD-ROM drive directly connected to your computer.

For Microsoft Windows NT 4.0, Microsoft Windows 2000 or Microsoft Windows XP, this CD-ROM requires that you have Local Administrative rights in order to use. See the System requirements section for additional details.

System Requirements:

Use of the Cummins Service Publications Electronic Books on CD-ROM requires Adobe Acrobat, Adobe Acrobat Reader, or Adobe Reader software to be pre-installed on your computer. This product has been tested for compatibility with Adobe Acrobat software versions 5.0, 6.0 and 7.0. It may function properly with versions later than Adobe Acrobat 7.0, but testing has not been performed. Acrobat Reader is available as a free download from www.adobe.com.

The Cummins Service Publications Electronic Books on CD-ROM product requires the following system components:

- Microsoft Windows Auto-Play must be enabled on your computer (it is enabled by default when Windows is installed)
- CD-ROM Drive
- Color Monitor with at least 800x600 resolution graphics
- Microsoft Windows XP Professional or Microsoft Windows 2000 Professional. This CD-ROM may be compatible with Microsoft Windows 98 SE, Microsoft Windows NT 4.0, or Microsoft Windows XP Home Edition, but testing has not been performed.
- Recommended memory, processor speed and available hard-disk space is in accordance with respective Microsoft Operating System Guidelines, as well as Adobe Acrobat system requirements listed later in these instructions.

Note: The Cummins Service Publications Electronic Books on CD-ROM product is not Macintosh compatible.

About required Local Administrative Rights:

The copy protection system used on this product requires direct access to CD-ROM drives in order to authenticate copy protected discs.

In order to allow the software to enable direct access to CD-ROM drives rights under Microsoft Windows, if you are using Microsoft Windows NT 4.0, Microsoft Windows 2000 or Microsoft Windows XP, your logon account/profile must have Local Administrative Rights on the computer you will be using your Cummins Service Publications Electronic Book on CD-ROM with. If this computer is set up in Restricted Mode, and your logon account/profile does not have Local Administrative Rights, then, with approval of your I.T. department or the owner of your computer, you can choose from the following options to allow the Cummins Service Publications Electronic Book on CD-ROM to function properly:

- Have your computer account enabled to have Local Administrative rights and then you can run the Cummins Service Publications Electronic Book on CD-ROM - OR -
- Have a user with Local Administrative Rights logon to your computer and run the CD-ROM one time. By doing this, the necessary files will be loaded to your computer and your computer will be enabled to have direct access to CD-ROM drives. Then restart this computer. It is very important to restart the computer after you have done this. For all future needs, you can run the Cummins Service Publications Electronic Book on CD-ROM under your own account, without requiring your logon account/profile to have Local Administrative Rights. (Note: This needs to be done only once for any Cummins Service Publications Electronic Book on CD-ROM and then does not need to be done again for other Cummins Service Publications Electronic Book on CD-ROM titles you may own.)

Cummins Service Publications Electronic Books on CD-ROM Information **(continued)**

About the Copy Protection Software:

- This product may upgrade the proprietary copy protection software files it uses that are placed on your computer system to a new version, if an older version exists on your computer. If you have CD-ROM copy protected items from other companies and they use older versions of the same HexaLock copy protection software that the Cummins Service Publications Electronic Books on CD-ROM uses, it may render them incompatible for use on your computer.

Adobe Acrobat Reader 5.0 system requirements:

- PC Compatible computer w/ Intel® Pentium® processor
- One of the following Microsoft® Windows Operating Systems:
 - Microsoft Windows 98 SE
 - Microsoft Windows Millennium Edition
 - Microsoft Windows NT® 4.0 with Service Pack 5
 - Microsoft Windows 2000
 - Microsoft Windows XP
- 64MB of RAM
- 24MB of available hard-disk space
- Additional 70MB of hard-disk space for Asian fonts (optional)
(Asian fonts are not required for Cummins Service Publications Electronic Books on CD-ROM product.)

Adobe Reader 6.0.1 system requirements:

- PC Compatible computer w/ Intel Pentium processor
- One of the following Microsoft Windows Operating Systems:
 - Microsoft Windows 98 SE
 - Microsoft Windows Millennium Edition
 - Microsoft Windows NT 4.0 with Service Pack 6
 - Microsoft Windows 2000 with Service Pack 2
 - Microsoft Windows XP Professional or Home Edition
 - Microsoft Windows XP Tablet PC Edition
- 32MB of RAM (64MB recommended)
- 60MB of available hard-disk space
- Microsoft Internet Explorer 5.0.1, 5.5, 6.0, or 6.1

Adobe Reader 7.0 system requirements:

- PC Compatible computer w/ Intel Pentium processor
- One of the following Microsoft Windows Operating Systems:
 - Microsoft Windows 2000 with Service Pack 2
 - Microsoft Windows XP Professional or Home Edition
 - Microsoft Windows XP Tablet PC Edition
- 128MB of RAM
- Up to 90MB of available hard-disk space
- Microsoft Internet Explorer 5.5 or higher

How to Use the Cummins Service Publications Electronic Book on CD-ROM:

To use the CD-ROM, simply insert the CD-ROM into your computer and it should automatically run, open Adobe Acrobat and open the Electronic Book. (This happens with Microsoft Windows Auto-Play functionality, and Adobe Acrobat pre-loaded by you on your computer).

Cummins Service Publications Electronic Books on CD-ROM Information (continued)

Helpful Support Tips:

- If Windows Auto-Play is not enabled, try re-enabling it, or navigate with Windows Explorer to your CD-ROM drive and double click on the CD-ROM drive letter to open it. Then double-click on the program named "clickhere". (Do not attempt to directly open the PDF file by clicking on the PDF document.)
- In rare occasions, after inserting the CD-ROM you may receive a notice from Adobe Acrobat that it "could not open the PDF because it is either not a supported file type or the file has been corrupted". This can occur in rare occasions due to application timing issues. If this occurs there are several options to remedy the situation: 1) Simply click OK on the notice, eject the CD-ROM and re-insert it to have it restart the program, or 2) Click OK on the notice and navigate with Windows Explorer to your CD-ROM drive and double click on the CD-ROM drive letter to open it. Then double-click on the program named "clickhere". (Do not attempt to directly open the PDF file by clicking on the PDF document) or 3) Click OK on the notice, eject the CD-ROM, restart your computer and after the system has restarted, re-insert the CD-ROM and have it automatically run.
- If the Cummins Service Publications Electronic Books on CD-ROM does not function, see the prior section on "About required Local Administrative Rights:" in this documentation and verify you have Local Administrative Rights on your computer in order to run the CD-ROM.

Special Instructions for Cummins PowerSweep PC Users:

(This only applies to Cummins Inc. & Distributor Employees):

Cummins PowerSweep PC users that DO NOT have Local Administrative rights to their PC will require a HexaLock patch software installation. If you are a Cummins Inc. or Distributor Employee who wants to use these CD-ROM's, and you have a PowerSweep PC – please order the 'HexaLock' software from the Cummins Software Shelf. The Software Shelf personnel will contact you to arrange installation. Software will be installed remotely by Software Shelf personnel. Once software is installed, first reboot your PC, then attempt to read your encrypted CD-ROM manual while Cummins Software Shelf personnel are still on the telephone.

Electronic Book Technical Support:

Support for this product is available from Monday through Friday weekly, excluding Holidays, from 8 a.m. to 5 p.m. You may call (502) 540-4981 for telephone support. For e-mail support, please e-mail ebooksupport@merrickind.com.

CD-ROM Media Replacement Options:

Up to 90 days from date of purchase:

Within the first 90 days from your date of purchase, if your copy of an Electronic Book on CD-ROM does not function, and after a Cummins Electronic Book Technical Support Technician has confirmed the situation and authorized its replacement by providing you an RMA#, you may send back the CD-ROM for a free replacement. To do so, you must package the CD-ROM and ship/mail, with postage pre-paid by you, to the below address. You must also include a photocopy of the original invoice for proof of purchase of the publication clearly indicating the bulletin # and the purchase date. The RMA# must be on the address information of the package. If the proof of purchase copy of the invoice is not enclosed, your request will not be able to be processed and will not be returned. Delivery of the replacement will be shipped to you at no charge. Allow 3 to 4 weeks for your receipt of replacement copy. Note: Return only the non-functional CD-ROM, do not return the entire printed publication. The replacement CD-ROM maintains the original purchase/invoice date for the purposes of this replacement policy. This policy is subject to change at any time, without notice. For a copy of the most current replacement options policy, please e-mail ebooksupport@merrickind.com with your request.

Media Replacement Ship to Address:

Attn: Cummins Service Publications Electronic Books Technical Support
RMA#: XXXXXX (where XXXXXX is the RMA#)
808 E. Liberty Street
Louisville, KY 40204 U.S.A.

Cummins Service Publications Electronic Books on CD-ROM are Copyright © Cummins Inc.
Adobe Acrobat Reader is a registered trademark of Adobe Systems Incorporated.
Microsoft, Windows, and Windows NT are registered trademarks of Microsoft Corporation.
Intel and Pentium are trademarks of Intel Corporation.
HexaLock is Copyright © HexaLock, Ltd.
All other names and products used herein are trademarks for their respective owner.

Section L - Service Literature

Section Contents

	Page
Additional Service Literature	L-1
General Information.....	L-1
Cummins Customized Parts Catalog	L-3
General Information.....	L-3
Ordering the Customized Parts Catalog.....	L-3
Ordering by Telephone.....	L-3
Ordering On-Line.....	L-3
Service Literature Ordering Location	L-2
Contact Information.....	L-2



This Page Left Intentionally Blank

Additional Service Literature General Information

The following publications can be purchased:

Bulletin	Title of Publication
3379000	Air for Your Engine
3379001	Fuel for Cummins Engines Bulletin
3379009	Operation - Cold Weather Bulletin
3810340	Cummins Engine Oil Recommendations Bulletin
3666132	Coolant Requirements and Maintenance Bulletin
4021524	QSB4.5, QSB6.7, QSC8.3, and QSL9 CM850 Electronic Control Module Wiring Diagram
4021416	Troubleshooting and Repair Manual, CM850 Electronic Control System ISB, ISBe4, QSB4.5, QSB5.9, QSB6.7, ISC, QSC8.3, ISL, and QSL9 Engines
4021271	Service Manual, ISB, ISBe4, and QSB (Common Rail Fuel System) Series Engines
4056556	QSB6.7 Parts Catalog



Service Literature Ordering Location Contact Information

Region

United States and Canada

Ordering Location

Cummins Distributors

or

Credit Cards at 1-800-646-5609

or

Order online at www.powerstore.cummins.com

Cummins Distributors or Dealers

All Other Countries

Cummins Customized Parts Catalog

General Information

Cummins is pleased to announce the availability of a parts catalog compiled specifically for you. Unlike the generic versions of parts catalogs that support general high volume parts content; Cummins Customized catalogs contains only the new factory parts that were used to build your engine.

The catalog cover, as well as the content, is customized with you in mind. You can use it in your shop, at your worksite, or as a coffee table book in your RV or boat. The cover contains your name, company name, address, and telephone number. Your name and engine model identification even appears on the catalog spine. Everybody will know that Cummins created a catalog specifically for you.

This new catalog was designed to provide you with the exact information you need to order parts for your engine. This will be valuable for customers that do not have easy access to the Cummins Electronic Parts Catalog or the Cummins Parts Microfilm System.

Additional Features of the Customized Catalog include:

- Engine Configuration Data
- Table of Contents
- Separate Option and Parts Indexes
- Service Kits (when applicable)
- ReCon Part Numbers (when applicable)

Ordering the Customized Parts Catalog

Ordering by Telephone

North American customers can contact their Cummins Distributor or call Gannett Direct Marketing Services at 1-800-646-5609 and order by credit card. Outside North America order on-line or make an International call to Gannett at (+ +)502-454-6660.

Ordering On-Line

The Customized Parts Catalog can be ordered On-Line from the Cummins Powerstore by credit card. Contact the Powerstore at WWW.POWERSTORE.CUMMINS.COM

Contact GDMS or the CUMMINS POWERSTORE for the current price; Freight may be an additional expense.

Information we need to take your Customized Parts Catalog Order. This information drives the cover content of the CPC.

- Customer Name
- Street Address
- Company Name (optional)
- Telephone no.
- Credit Card No.
- Cummins Engine Serial Number (located on the engine data plate)
- Please identify the required media: Printed Catalog, CD-ROM, or PDF File

Unfortunately not all Cummins Engines can be supported by this parts catalog. Engines older than 1984 or newer than 3 months may not have the necessary parts information to compile a catalog. We will contact you if this occurs and explain why we are unable to fill your order.

Customized Parts Catalogs are produced specifically for a single customer. This means they are not returnable for a refund. If we make an error and your catalog is not useable, we will correct that error by sending you a new catalog.

Section M - Component Manufacturers

Section Contents

	Page
Component Manufacturers' Addresses	M-1
Air Compressors.....	M-1
Air Cylinders.....	M-1
Air Heaters.....	M-1
Air Starting Motors.....	M-1
Alternators.....	M-1
Auxiliary Brakes.....	M-1
Belts.....	M-1
Catalytic Converters.....	M-1
Coolant Level Switches.....	M-1
Clutches.....	M-1
Coolant Heaters.....	M-2
Drive Plates.....	M-2
Electric Starting Motors.....	M-2
Electronic Switches.....	M-2
Engine Protection Controls.....	M-2
Fan Clutches.....	M-2
Fans.....	M-2
Fault Lamps.....	M-2
Filters.....	M-2
Flexplates.....	M-2
Fuel Coolers.....	M-2
Fuel Pumps.....	M-2
Fuel Warmers.....	M-2
Gauges.....	M-3
Governors.....	M-3
Heat Sleeves.....	M-3
Hydraulic and Power Steering Pumps.....	M-3
In-Line Connectors.....	M-3
Oil Heaters.....	M-3
Prelubrication Systems.....	M-3
Radiators.....	M-3
Throttle Assemblies.....	M-3
Torque Converters.....	M-3

This Page Left Intentionally Blank

Component Manufacturers' Addresses

NOTE: The following list contains addresses and telephone numbers of suppliers of accessories used on Cummins engines. Suppliers can be contacted directly for any specifications **not** covered in this manual.

Air Compressors

Bendix Heavy Vehicles Systems
Div. of Allied Automotive
901 Cleveland Street
Elyria, OH 44036
Telephone: (216) 329-9000

Holset Engineering Co., Inc.
1320 Kemper Meadow Drive
Suite 500
Cincinnati, OH 45240
Telephone: (513) 825-9600

Midland-Grau
Heavy Duty Systems
Heavy Duty Group Headquarters
10930 N. Pamaona Avenue
Kansas City, MO 64153
Telephone: (816) 891-2470

Air Cylinders

Bendix Ltd.
Douglas Road
Kingswood
Bristol
England
Telephone: 0117-671881

Catching Engineering
1733 North 25th Avenue
Melrose Park, IL 60160
Telephone: (708) 344-2334

TEC - Hackett Inc.
8909 Rawles Avenue
Indianapolis, IN 46219
Telephone: (317) 895-3670

Air Heaters

Fleetguard, Inc.
1200 Fleetguard Road
Cookeville, TN 38502
Telephone: (615) 526-9551

Kim Hotstart Co.
P.O. Box 11245
Spokane, WA 99211-0245
Telephone: (509) 534-6171

Air Starting Motors

Ingersoll Rand
Chorley New Road
Horwich
Bolton
Lancashire
England
BL6 6JN
Telephone: 01204-65544

Ingersoll-Rand Engine
Starting Systems
888 Industrial Drive
Elmhurst, IL 60126
Telephone: (708) 530-3875

StartMaster
Air Starting Systems
A Division of Sycon Corporation
9595 Cheney Avenue
P. O. Box 491
Marion, OH 43302
Telephone: (614) 382-5771

Alternators

Robert Bosch Ltd.
P.O. Box 98
Broadwater Park
North Orbital Road
Denham
Uxbridge
Middlesex UD9 5HG
England
Telephone: (0)1895-838383

Prestolite Electric
Cleveland Road
Leyland
PR5 1XB
England
Telephone: (0)1772-421663

C. E. Niehoff & Co.
2021 Lee Street
Evanston, IL 60202
Telephone: (708) 866-6030

Delco-Remy America
2401 Columbus Avenue
P.O. Box 2439
Anderson, IN 46018
Telephone: (317) 646-3528

Leece-Neville Corp.
400 Main Street
Arcade, NY 14009
Telephone: (716) 492-1700

Auxiliary Brakes

The Jacobs Manufacturing Company
Vehicle Equipment Division
22 East Dudley Town Road
Bloomfield, CT 06002
Telephone: (203) 243-1441

Belts

T.B.A. Belting Ltd.
P.O. Box 77
Wigan
Lancashire
WN2 4XQ
England
Telephone: (0)1942-259221

Dayco Mfg.
Belt Technical Center
1955 Enterprize
Rochester Hills, MI 48309
Telephone: (810) 853-8300

Gates Rubber Company
900 S. Broadway
Denver, CO 80217

Goodyear Tire and
Rubber Company
Industrial Products Div.
2601 Fortune Circle East
Indianapolis, IN 46241
Telephone: (317) 898-4170

Catalytic Converters

Donaldson Company, Inc.
1400 West 94th Street
P.O. Box 1299
Minneapolis, MN 55440
Telephone: (612) 887-3835

Nelson Division
Exhaust and Filtration Systems
1801 U.S. Highway 51 P.O. Box 428
Stoughton, WI 53589
Telephone: (608) 873-4200

Walker Manufacturing
3901 Willis Road
P.O. Box 157
Grass Lake, MI 49240
Telephone: (517) 522-5500

Coolant Level Switches

Robertshaw Controls Company
P.O. Box 400
Knoxville, TN 37901
Telephone: (216) 885-1773

Clutches

Twin Disc International S.A.
Chaussee de Namur
Nivelles
Belguim
Telephone: 067-224941

Twin Disc Incorporated
1328 Racine Street
Racine, WI 53403
Telephone: (414) 634-1981

Coolant Heaters

Fleetguard, Inc.
1200 Fleetguard Road
Cookeville, TN 38502
Telephone: (615) 526-9551

Drive Plates

Detroit Diesel Allison
Division of General Motors
Corporation
P.O. Box 894
Indianapolis, IN 46206-0894
Telephone: (317) 242-5000

Electric Starting Motors

Prestolite Electrics
Cleveland Road
Leyland
PR5 1XB
England
Telephone: 01772-421663

Delco-Remy America
2401 Columbus Avenue
P.O. Box 2439
Anderson, IN 46018
Telephone: (317) 646-3528

Leece-Neville Corp.
400 Main Street
Arcade, NY 14009
Telephone: (716) 492-1700

Nippondenso Inc.
2477 Denso Drive
P.O. Box 5133
Southfield, MI 48086
Telephone: (313) 350-7500

Electronic Switches

Cutler-Hammer Products
Eaton Corporation
4201 N. 27th Street
Milwaukee, WI 53216
Telephone: (414) 449-6600

Engine Protection Controls

Flight Systems Headquarters
Hempt Road
P.O. Box 25
Mechanicsburg, PA 17055
Telephone: (717) 697-0333

The Nason Company
2810 Blue Ridge Blvd.
West Union, SC 29696
Telephone: (803) 638-9521

Teddington Industrial
Equipment
Windmill Road
Sunbury on Thames
Middlesex
TW16 7HF
England
Telephone: (0)9327-85500

Fan Clutches

Kysor Cooling Systems N.A.
6040 West 62nd Street
Indianapolis, IN 46278
Telephone: (317) 328-3330

Holset Engineering Co. Ltd.
ST Andrews Road
Huddersfield, West Yorkshire
England HD1 6RA
Telephone: (0)1484-22244

Horton Industries, Inc.
P.O. Box 9455
Minneapolis, MN 55440
Telephone: (612) 378-6410

Rockford Clutch Company
1200 Windsor Road
P.O. Box 2908
Rockford, IL 61132-2908
Telephone: (815) 633-7460

Fans

Truflo Ltd.
Westwood Road
Birmingham
B6 7JF
England
Telephone: (0)121-3283041

Hayes-Albion Corporation
Jackson Manufacturing Plant
1999 Wildwood Avenue
Jackson, MI 49202
Telephone: (517) 782-9421

Engineered Cooling Systems, Inc.
201 W. Carmel Drive
Carmel, IN 46032
Telephone: (317) 846-3438

Brookside Corporation
P.O. Box 30
McCordsville, IN 46055
Telephone: (317) 335-2014

TCF Aerovent Company
9100 Purdue Rd., Suite 101
Indianapolis, IN 46268-1190
Telephone: (317) 872-0030

Kysor-Cadillac
1100 Wright Street
Cadillac, MI 49601
Telephone: (616) 775-4681

Schwitzer
6040 West 62nd Street
P.O. Box 80-B
Indianapolis, IN 46206
Telephone: (317) 328-3010

Fault Lamps

Cutler-Hammer Products
Eaton Corporation
4201 N. 27th Street
Milwaukee, WI 53216
Telephone: (414) 449-6600

Filters

Fleetguard International Corp.
Cavalry Hill Industrial Park
Weedon
Northampton NN7 4TD
England
Telephone: 01327-341313

Fleetguard, Inc.
1200 Fleetguard Road
Cookeville, TN 38502
Telephone: 1-800-22-Filters
(1-800-223-4583)

Flexplates

Corrugated Packing and
Sheet Metal
Hamsterley
Newcastle Upon Tyne
England
Telephone: (0)1207-560-505

Allison Transmission
Division of General Motors
Corporation
P.O. Box 894
Indianapolis, IN 46206-0894
Telephone: (317) 242-5000

Midwest Mfg. Co.
29500 Southfield Road, Suite 122
Southfield, MI 48076
Telephone: (313) 642-5355

Wohlert Corporation
708 East Grand River Avenue
P.O. Box 20217
Lansing, MI 48901
Telephone: (517) 485-3750

Fuel Coolers

Hayden, Inc.
1531 Pomona Road
P.O. Box 848
Corona, CA 91718-0848
Telephone: (909) 736-2665

Fuel Pumps

Robert Bosch Corp.
Automotive Group
2800 South 25th Ave.
Broadview, IL 60153

Fuel Warmers

Fleetguard, Inc.
1200 Fleetguard Road
Cookeville, TN 38502
Telephone: (615) 526-9551

QSB Series**Section M - Component Manufacturers****Gauges**

Grasslin U.K. Ltd.
Vale Rise
Tonbridge
Kent
TN9 1TB
England
Telephone: (0)1732-359888

Datcon Instruments
P.O. Box 128
East Petersburg, PA 17520
Telephone: (717) 569-5713

Rochester Gauges, Inc.
11616 Harry Hines Blvd.
P.O. Box 29242
Dallas, TX 75229
Telephone: (214) 241-2161

Governors

Woodward Governor Co.
P.O. Box 1519
Fort Collins, CO 80522
Telephone: (303) 482-5811
(800) 523-2831

Barber Colman Co.
1354 Clifford Avenue
Loves Park, IL 61132
Telephone: (815) 637-3000

United Technologies
Diesel Systems
1000 Jorie Blvd.
Suite 111
Oak Brook, IL 69521
Telephone: (312) 325-2020

Heat Sleeves

Bentley Harris Manufacturing Co.
100 Bentley Harris Way
Gordonville, TN 38563
Telephone: (313) 348-5779

Hydraulic and Power Steering Pumps

Honeywell Control Systems Ltd.
Honeywell House
Arlington Business Place
Bracknell
Berks RG12 1EB
Telephone: (0)1344-656000

Sperry Vickers
P.O. Box 302
Troy, MI 48084
Telephone: (313) 280-3000

Z.F.
P.O. Box 1340
Grafvonsoden Strasse
5-9 D7070
Schwaebisch Gmuend
Germany
Telephone: 7070-7171-31510

In-Line Connectors

Pioneer-Standard Electronics, Inc.
5440 Neiman Parkway
Solon, OH 44139
Telephone: (216) 349-1300

Deutsch
Industrial Products Division
37140 Industrial Avenue
Hemet, CA 92343
Telephone: (714) 929-1200

Oil Heaters

Fleetguard, Inc.
1200 Fleetguard Road
Cookeville, TN 38502
Telephone: (615) 526-9551

Kim Hotstart Co.
P.O. Box 11245
Spokane, WA 99211-0245
Telephone: (509) 534-6171

Prelubrication Systems

RPM Industries, Inc.
Suite 109
55 Hickory Street
Washington, PA 15301
Telephone: (412) 228-5130

Radiators

JB Radiator Specialties, Inc.
P.O. Box 292087
Sacramento, CA 95829-2087
Telephone: (916) 381-4791

**Component Manufacturers' Addresses
Page M-3**

The G&O Manufacturing Company
100 Gando Drive
P.O. Box 1204
New Haven, CT 06505-1204
Telephone: (203) 562-5121

Young Radiator Company
2825 Four Mile Road
Racine, WI 53404
Telephone: (910) 271-2397

L and M Radiator, Inc.
1414 East 37th Street
Hibbing, MN 55746
Telephone: (218) 263-8993

Throttle Assemblies

Williams Controls, Inc.
14100 SW 72nd Avenue
Portland, OR 97224
Telephone: (503) 684-8600

Torque Converters

Twin Disc International S.A.
Chaussee de Namur
Nivelles
Belgium
Telephone: 067-224941

Twin Disc Incorporated
1328 Racine Street
Racine, WI 53403-1758
Telephone: (414) 634-1981

Rockford Powertrain, Inc.
Off-Highway Systems
1200 Windsor Road
P.O. Box 2908
Rockford, IL 61132-2908
Telephone: (815) 633-7460

Modine Mfg. Co.
1500 DeKoven Avenue
Racine, WI 53401
Telephone: (414) 636-1640

Section S - Service Assistance

Section Contents

	Page
Distributors - International	S-31
Locations.....	S-31
Distributors and Branches	S-4
Australia.....	S-22
Canada.....	S-19
New Zealand.....	S-26
United States.....	S-4
Division and Regional Offices	S-2
Locations.....	S-2
Emergency and Technical Service	S-1
General Information.....	S-1
Problem Solving	S-1
General Information.....	S-1
Regional Offices - International	S-27
Locations.....	S-27
Routine Service and Parts	S-1
General Information.....	S-1

This Page Left Intentionally Blank

Routine Service and Parts

General Information

Personnel at Cummins Authorized Repair Locations can assist you with the correct operation and service of your engine. Cummins has a worldwide service network of more than 5,000 Distributors and Dealers who have been trained to provide sound advice, expert service, and complete parts support. Check the telephone directory yellow pages or refer to the directory in this section for the nearest Cummins Authorized Repair Location.

Emergency and Technical Service

General Information

The Cummins Customer Assistance Center provides a 24-hour, toll free telephone number to aid in technical and emergency service when a Cummins Authorized Repair Location can **not** be reached or is unable to resolve an issue with a Cummins product.

If additional assistance is required, call Toll-Free:

1-800-DIESELS
(1-800-343-7357)

- Includes all 50 states, Bermuda, Puerto Rico, Virgin Islands, and the Bahamas.
- Outside of North America contact your Regional Office. Telephone numbers and addresses are listed in the International Directory.



Problem Solving

General Information

Normally, any problem that arises with the sale, service, or repair of your engine can be handled by a Cummins Authorized Repair Location in your area. Refer to the telephone directory yellow pages for the one nearest you. If the problem has **not** been handled satisfactorily, follow the steps outlined below:

1. If the disagreement is with a Dealer, talk to the Cummins Distributor with whom he has his service agreement.
2. If the disagreement is with a Distributor, call the nearest Cummins Division or Regional Office; however, most problems are solved below the Division or Regional office level. Telephone numbers and addresses are listed in this section. Before calling, write down the following information:
 - a. Engine model and serial number
 - b. Type and make of equipment
 - c. Total kilometers [miles] or hours of operation
 - d. Warranty start date
 - e. Nature of problem
 - f. Summary of the current problem arranged in the order of occurrence
 - g. Name and location of the Cummins Distributor or Dealer
12. If a problem can **not** be resolved satisfactorily through your Cummins Authorized Repair Location or Division Office, write to:

Cummins Customer Assistance Center - 41403, Cummins Inc., Box 3005, Columbus, IN 47202-3005

Division and Regional Offices - Locations

Australia Regional Office	Cummins Engine Company Pty. Ltd.	2 Caribbean Drive Scoresby, Victoria 3179 Australia Telephone: (61-3) 9765-3222 FAX: (61-3) 9763-0079 NOTE: This office also serves New Zealand.
Cummins Americas Regional Office	Cummins Americas Inc.	3350 SW 148 Avenue Suite 205 Miramar, FL 33027 Telephone: [1-954] 431-5511 Fax: [1-954] 433-5797 NOTE: This office serves Puerto Rico and South America excluding Brazil.
China Beijing	Cummins (China) Investment Co. Ltd	28F, Tower A, GATEWAY, No.18, Xiaguangli North Road, East Third Ring, Chaoyang District Beijing, Beijing ZIP / Postal Code: 100027 China Telephone: [86-10] 84548888 Telefax: [86-10] 67876347
Brazil	Cummins Brasil Ltda.	Rua Jati, 266 07180-900 Guarulhos Sao Paulo Brazil Phone: [55-11] 6465-9811 Fax: [55-11] 6412-1483
Daventry	Cummins Engine Company Ltd (Africa)	Royal Oak Way South Daventry, Northants ZIP / Postal Code: NN11 5NU United Kingdom Telephone: [44-1327] 886000 Telefax: [44-1327] 886106
Daventry	Cummins Engine Co. Ltd (Serving Czech Republic)	Royal Oak Way South Daventry, Northants ZIP / Postal Code: NN11 5NU United Kingdom Telephone: [44-1327] 886000 Telefax: [44-1327] 886106
Daventry	Cummins Engine Company Ltd (Middle East)	Royal Oak Way South Daventry, Northants ZIP / Postal Code: NN11 5NU United Kingdom Telephone: [44-1327] 886000 Telefax: [44-1327] 886106
Dubai United Arab Emirates	Cummins Middle East FZE	Units ZF 5/6 Jebel Ali Free Zone P.O.Box No 17636 Dubai United Arab Emirates Phone: [971-4] 883 8998 Fax: [971-4] 883 7971

India Pune	Cummins India Ltd.	Kothrud Pune, Maharashtra ZIP / Postal Code: 411029 India Telephone: [91-20] 2538-5435 / 0240 / 1105 Telefax: [91-20] 2538-0125
Korea Seoul	Cummins Korea Ltd.	25th floor, ASEM tower, 159-1, Samsung-Dong Kangnam-ku, Seoul ZIP / Postal Code: 135-798 South Korea Telephone: [82-2] 3420-0901 Telefax: [82-2] 3452-4113 / 539-6569
SLP Mexico	Cummins, S. de R.L. de C.V.	Arquimedes No. 209 Col. Polanco Mexico, Distrito Federal ZIP / Postal Code: 11560 Mexico Telephone: [52-5] 254-3822 / 3783 / 3622 Telefax: [52-5] 254-3645
Russia Moscow	Cummins Engine Company, Inc.	Park Place Office E708, 113/1 Leninskiy Prospect Moscow ZIP / Postal Code: 117198 Russia Telephone: [7-495] 956-51-22 / 23 Telefax: [7-495] 956-53-62
Singapore	Cummins Diesel Sales Corporation	8 Tanjong Penjuru Singapore ZIP / Postal Code: 609019 Singapore Telephone: [65] 6265-0155

Distributors and Branches - United States

Alabama	Birmingham	Cummins Mid-South, LLC 2200 Pinson Highway P.O. Box 1147 Birmingham, AL 35217 Telephone: (205) 841-0421 FAX: (205) 849-5926
Alabama	Mobile	Cummins Mid-South, LLC 1924 N. Beltline Hwy. Mobile, AL 36617 Telephone: (334) 456-2236 FAX: (334) 452-6419
Alaska	Anchorage	Cummins Northwest, Inc. 2618 Commercial Drive Anchorage, AK 99501-3095 Telephone: (907) 279-7594 FAX: (907) 276-6340
Arizona	Phoenix	Cummins Rocky Mountain, LLC 2239 N. Black Canyon Hgwy Phoenix, AZ 85009 Telephone: (602) 252-8021 FAX: (602) 253-6725
Arkansas	Little Rock	Cummins Mid-South, Inc. 6600 Interstate 30 Little Rock, AR 72209 Telephone: Sales: (501) 569-5600 Service: (501) 569-5656 Parts: (501) 569-5613 FAX: (501) 565-2199
California	San Leandro	Cummins West, Inc. 14775 Wicks Blvd. San Leandro, CA 94577-6779 Telephone: (510) 351-6101 FAX: (510) 352-3925
California	Arcata	Cummins West, Inc. 4751 West End Road Arcata, CA 95521 Telephone: (707) 822-7392 FAX: (707) 822-7585
California	Bakersfield	Cummins West, Inc. 4601 East Brundage Lane Bakersfield, CA 93307 Telephone: (805) 325-9404 FAX: (805) 861-8719
California	Fresno	Cummins West, Inc. 5333 N Cornelia Ave Fresno, CA 93722 Telephone: (559) 277-6760 FAX: (559) 277-6769

California	Redding	Cummins West, Inc. 20247 Charlanne Drive Redding, CA 96002 Telephone: (530) 222-4070 FAX: (530) 224-4075
California	Stockton	Cummins West, Inc. 5250 Claremont Ave Suite 204 Stockton, California 95207, USA Telephone: (209) 472-3460 FAX: (209) 472-3450
California	West Sacramento	Cummins West, Inc. 875 Riverside Parkway West Sacramento, CA 95605-1502 Telephone: (916) 371-0630 FAX: (916) 371-2849
California	Los Angeles	Cummins Cal Pacific Inc. 1939 Deere Avenue (Irvine) Irvine, CA 92606 Telephone: (949) 253-6000 FAX: (949) 253-6070
California	Montebello	Cummins Cal Pacific Inc. 1105 South Greenwood Avenue Montebello, CA 90640 Telephone: (323) 728-8111 FAX: (323) 889-7499
California	Bloomington	Cummins Cal Pacific Inc. 3061 S. Riverside Avenue Bloomington, CA 92316 Telephone: (909) 877-0433 FAX: (909) 877-3787
California	San Diego	Cummins Cal Pacific Inc. 310 N. Johnson Avenue El Cajon, CA 92020 Telephone: (619) 593-3093 FAX: (619) 593-0600
California	Ventura	Cummins Cal-Pacific Inc. 3958 Transport St. Ventura, CA 93003 Telephone: (805) 644-7281 FAX: (805) 644-7284
Colorado	Denver	Cummins Rocky Mountain, Inc. 8211 East 96th Ave Henderson, Colorado 80640 Telephone: (303) 287-0201 FAX: (303) 288-7080
Colorado	Grand Junction	Cummins Rocky Mountain, Inc. 2380 U.S. Highway 6 & 50 P.O. Box 339 Grand Junction, CO 81501 Telephone: (970) 242-5776 FAX: (970) 243-5494

Connecticut	Rocky Hill	Cummins Metropower, Inc. 914 Cromwell Ave. Rocky Hill, CT 06067 Telephone: (860) 529-7474 FAX: (860) 529-7524
Florida	Ft. Myers	Cummins Power South, LLC 2671 Edison Avenue Ft. Myers, FL 33916 Telephone: (941) 337-1211 FAX: (941) 337-5374
Florida	Jacksonville	Cummins Power South 755 Pickettville Rd. Jacksonville, FL 32220 Telephone: (904) 378-1902 FAX: (904) 378-1904
Florida	Hialeah (Miami)	Cummins Power South, LLC 9900 N.W. 77th Avenue Hialeah Gardens, FL 33016 Telephone: (305) 821-4200 FAX: (305) 557-2992
Florida	Ocala	Cummins Power South, LLC 321 Southwest 52nd Ave. Ocala, FL 34474-1892 Telephone: (352) 861-1122 FAX: (352) 861-1130
Florida	Orlando	Cummins Power South, LLC 4020 North Orange Blossom Trail Orlando, FL 32810 Telephone: (407) 298-2080 FAX: (407) 290-8727
Florida	Tampa	Cummins Power South, LLC 5421 N. 59th Street Tampa, FL 33610 Telephone: (813) 621-7202 FAX: (813) 621-8250
Florida		Cummins Power South, LLC 5906 Breckenridge Parkway Suite J Tampa, FL 33610 Telephone: (813) 664-5868 FAX: (813) 623-5442
Florida		Cummins Power South, LLC 5912 E. Hillsborough Avenue Tampa, FL 33610 Telephone: (813) 626-1101 FAX: (813) 628-8888
Florida		Cummins Power South, LLC 6606 N. 56th Street Tampa, FL 33610 Telephone: (813) 623-3330 FAX: (813) 628-4162

Georgia	Atlanta	Cummins South, Inc. 100 University Ave. S.W. Atlanta, Georgia 30315-2202 Telephone: (404) 527-7800 FAX: (404) 527-7832
Georgia		Cummins South, Inc. 5125 Georgia Highway 85 College Park, GA 30349 Telephone: (404) 763-0151 FAX: (404) 766-2132
Georgia	Albany	Cummins South, Inc. 1915 W. Oakridge Drive Albany, GA 31707-4938 Telephone: (912) 888-6210 FAX: (912) 883-1670
Georgia	Augusta	Cummins South, Inc. 1255 New Savannah Road Augusta, GA 30901-3891 Telephone: (706) 722-8825 FAX: (706) 722-7553
Georgia	Savannah	Cummins South, Inc. 8 Interchange Court Savannah, GA 31401-1627 Telephone: (912) 232-5565 FAX: (912) 232-5145
Hawaii	Kapolei	Cummins West Inc. 91-230 Kalaeloa Blvd. Kapolei, HI 96707 Telephone: (808) 682-8110 FAX: (808) 682-8477
Idaho	Boise	Cummins Rocky Mountain, LLC 8949 So. Federal Way City Boise, Idaho 84716 Telephone: (208) 336-5000 FAX: (208) 338-5436
Illinois	Chicago	Cummins Power, LLC 7145 Santa Fe Drive Hodgkins, IL 60525 Telephone: (708) 579-9222 FAX: (708) 352-7547
Illinois	Bloomington	Cummins Mid-States Power, Inc. (at U.S. 51 N and I-55) 414 W. Northtown Road Bloomington-Normal, IL 61761 Telephone: (309) 452-4454 FAX: (309) 452-1642
Illinois	Onan Branch	Cummins/Onan Northern Illinois 8745 W. 82nd Place Justin, IL 60458 Telephone: (708) 563-7070 FAX: (708) 563-7095

Illinois	Madison	Cummins Mid-South, LLC 222 SR-203 Madison, Illinois 62060 Telephone: (618) 798-9512 FAX: (618) 798-9521
Illinois	Rock Island	Cummins Central Power, LLC 7820 - 42nd Street West Rock Island, IL 61201 Telephone: (309) 787-4300 FAX: (309) 787-4397
Indiana	Indianapolis	Cummins Mid-States Power, Inc. P.O. Box 42917 3762 West Morris Street Indianapolis, IN 46242-0917 Telephone: (317) 243-7979 FAX: (317) 240-1925
Indiana		Cummins Mid-States Power, Inc. P.O. Box 42917 3661 West Morris St Indianapolis, IN 46241 Telephone: (317) 486-5287 FAX: (317) 486-5281
Indiana		Cummins Mid-States Power, Inc. 4301 W. Morris St. 3762 West Morris Street Indianapolis, IN 46241 Telephone: (317) 240-1967 FAX: (317) 240-1975
Indiana	Evansville	Cummins Cumberland, Inc. 7901 Highway 41 North Evansville, IN 47725 Telephone: (812) 867-4400 FAX: (812) 867-4411
Indiana	Ft. Wayne	Cummins Mid-States Power, Inc. 3415 Coliseum Blvd. West (At Jct. I-69 & 30/33) Ft. Wayne, IN 46808 Telephone: (219) 482-3691 FAX: (219) 484-8930
Indiana	Gary	Cummins Northern Illinois, Inc. 1440 Texas Street Gary, IN 46402 Telephone: (219) 885-5591 FAX: (219) 883-4817
Indiana	Indianapolis	Cummins Mid-States Power, Inc. 3661 West Morris St Indianapolis, IN 46241 Telephone: (317) 486-5287 FAX: (317) 486-5281
Iowa	Cedar Rapids	Cummins Central Power, LLC 625 - 33rd Avenue SW Cedar Rapids, IA 52404 Telephone: (319) 366-7537 (24 hours) FAX: (319) 366-7562

Iowa	Des Moines	Cummins Central Power, LLC 1680 N.E. 51st Avenue Des Moines, IA 50313 Telephone: (515) 262-9591 Parts: (515) 262-9744 FAX: (515) 262-0626
Kansas	Colby	Cummins Central Power, LLC 1880 South Range Colby, KS 67701 Telephone: (785) 462-3945 FAX: (785) 462-3970
Kansas	Garden City	Cummins Central Power, LLC 1285 Acraway Garden City, KS 67846 Telephone: (316) 275-2277 FAX: (316) 275-2533
Kansas	Wichita	Cummins Central Power, LLC 5101 North Broadway Wichita, KS 67219 Telephone: (316) 838-0875 FAX: (316) 838-0704
Kentucky	Louisville	Cummins Cumberland, Inc. (Corporate Office) 2301 Nelsonville Parkway Louisville, KY 40223 Telephone: (502) 254-7375 FAX: (502) 254-1215
Kentucky	Hazard	Cummins Cumberland, Inc. Highway 15 South Hazard, KY 41701 Telephone: (606) 436-5718 FAX: (606) 436-5038
Kentucky	Louisville	Cummins Cumberland, Inc. 9820 Bluegrass Parkway Louisville, KY 40299 Telephone: (502) 491-4263 FAX: (502) 499-0896
Louisiana	Morgan City	Cummins Mid-South, LLC 9508 Highway 90 E Amelia, LA 70340 Telephone: (504) 631-0576 FAX: (504) 631-0081
Louisiana	New Orleans	Cummins Mid-South, LLC 110 E. Airline Highway Kenner, LA 70062 Telephone: (504) 465-3412 FAX: (504) 465-3408
Maine	Scarborough	Cummins Northeast, Inc. 10 Gibson Road Scarborough, ME 04074 Telephone: (207) 883-8155 FAX: (207) 883-5526

Maryland	Baltimore	Cummins Power Systems, Inc. 1907 Park 100 Drive MD 21061 Telephone: (410) 590-8700 FAX: (410) 590-8731
Massachusetts	Boston	Cummins Northeast, Inc. 100 Allied Drive Dedham, MA 02026 Telephone: (781) 329-1750 FAX: (781) 329-4428
Massachusetts	Springfield	Cummins Northeast, Inc. 177 Rocus Street Springfield, MA 01104 Telephone: (413) 737-2659 FAX: (413) 731-1082
Michigan	Detroit (New Hudson)	Standby Power, Div. of Cummins Bridgeway, LLC 21810 Clessie Ct New Hudson, Michigan 48165 Telephone: (248) 573-1600
Michigan		Cummins Bridgeway, LLC 54240 Grand River Ave New Hudson, Michigan 48165 Telephone: (517) 573-1900
Michigan	Grand Rapids	Cummins Bridgeway, LLC 3715 Clay Avenue, S.W. Grand Rapids, MI 49508 Telephone: (616) 538-2250 FAX: (616) 538-3830
Michigan	Grand Rapids	Standby Power, Inc. 7580 Expressway Drive S.W. Grand Rapids, MI 49548 Telephone: (616) 281-2211 FAX: (616) 281-3177
Michigan	Iron Mountain	Cummins NPower, LLC 1901 Stevenson Avenue Iron Mountain, MI 49801 Telephone: (906) 774-2424 FAX: (906) 774-1190
Michigan	Saginaw	Cummins Bridgeway, LLC 722 N. Outer Drive Saginaw, MI 48605 Telephone: (989) 752-5200 FAX: (989) 752-4194
Minnesota	St. Paul	Cummins NPower, LLC 3030 Centre Pointe Drive Suite 500 Roseville, MN 55113 Telephone: (651) 636-1000 FAX: (651) 638-2442
Minnesota	Duluth	Cummins NPower, LLC 3115 Truck Center Drive Duluth, MN 55806-1786 Telephone: (218) 628-3641 FAX: (218) 628-0488

Mississippi	Jackson	Cummins Mid-South, LLC 325 New Highway 49 South Jackson, MS 39288-4224 Telephone: (601) 939-7016 FAX: (601) 932-7399
Missouri	Kansas City	Cummins Central Power, LLC 8201 NE Parvin Road Kansas City, MO 64161 Telephone: (816) 414-8200 FAX: (816) 414-8299
Missouri	Joplin	Cummins Central Power, LLC 3507 East 20th Street Joplin, MO 64801 Telephone: (417) 623-1661 FAX: (417) 623-1817
Missouri	Springfield	Cummins Central Power, LLC 3637 East Kearney Springfield, MO 65803 Telephone: (417) 862-0777 FAX: (417) 862-4429
Missouri	Columbia	Cummins Mid-South, LLC 5221 Highway 763 North Columbia, MO 65205 Telephone: (314) 449-3711 FAX: (314) 449-3712
Missouri	Sikeston	Cummins Mid-South, LLC 101 Keystone Drive Sikeston, MO 63801 Telephone: (573) 472-0303 FAX: (573) 472-0306
Missouri	Industrial Power Branch	Cummins Mid-South, LLC 3256 E. Outer Road Scott City, MO 63780 Telephone: (573) 335-7399 FAX: (573) 335-7062
Montana	Billings	Cummins Rocky Mountain, LLC 5151 Midland Road Billings, MT 59101 Telephone: (406) 245-4194 FAX: (406) 245-7923 Toll Free #: (800) 332-7788
Montana	Missoula	Cummins Northwest, Inc. 4950 North Reserve Street Missoula, MT 59802-1498 Telephone: (406) 728-1300 FAX: (406) 728-8523
Nebraska	Omaha	Cummins Great Plains Diesel, Inc. 5515 Center Street Omaha, NE 68106 Telephone: (402) 551-7678 (24 Hours) FAX: (402) 551-1952

Nebraska	Kearney	Cummins Central Power, LLC 515 Central Avenue Kearney, NE 68847 Telephone: (308) 234-1994 FAX: (308) 234-5776
Nevada	Elko	Cummins Rocky Mountain, LLC 5370 East Idaho Street Elko, NV 89801 Telephone: (702) 738-6405 FAX: (702) 738-1719
Nevada	Las Vegas	Cummins Rocky Mountain, LLC 2750 Losee Road North Las Vegas, NV 89030 Telephone: (702) 399-2614 FAX: (702) 399-7457
Nevada	Sparks	Cummins Rocky Mountain, LLC 150 Glendale Avenue Sparks, NV 89431 Telephone: (775) 331-4983 FAX: (775) 331-7429
New Jersey	Newark	Cummins Metropower, Inc. 41-85 Doremus Ave. Newark, NJ 07105 Telephone: (973) 491-0100 FAX: (973) 578-8873
New Mexico	Albuquerque	Cummins Rocky Mountain, LLC 1921 Broadway N.E. Albuquerque, NM 87102 Telephone: (505) 247-2441 FAX: (505) 842-0436
New Mexico	Farmington	Cummins Rocky Mountain, LLC 1101 North Troy King Road Farmington, NM 87401 Telephone: (505) 327-7331 FAX: (505) 326-2948
New York	Bronx	Cummins Metropower, Inc. 890 Zerega Avenue Bronx, NY 10473 Telephone: (718) 892-2400 FAX: (718) 892-0055
New York	Albany	Cummins Northeast, Inc. 101 Railroad Avenue Albany, NY 12205 Telephone: (518) 459-1710 FAX: (518) 459-7815
New York	Buffalo	Cummins Northeast, Inc. 480 Lawrence Bell Dr. Williamsville, NY 14221-7090 Telephone: (716) 631-3211 FAX: (716) 626-0799

New York	Syracuse	Cummins Northeast, Inc. 6193 Eastern Avenue Syracuse, NY 13211 Telephone: (315) 437-2751 FAX: (315) 437-8141
North Carolina	Charlotte	Cummins Atlantic, Inc. 11101 Nations Ford Road Charlotte, NC 28273 Telephone: (704) 588-1240 FAX: (704) 587-4870
North Carolina	Charlotte	Cummins Atlantic, Inc. 3700 North Interstate 85 Charlotte, NC 28206 Telephone: (704) 596-7401 FAX: (704) 596-3038
North Carolina	Greensboro	Cummins Atlantic, Inc. 513 Preddy Boulevard > = reensboro, NC 27406 Telephone: (336) 275-4531 FAX: (336) 275-8304
North Dakota	Fargo	Cummins NPower, LLC 3801 - 34th Ave. SW Fargo, ND 58104 Telephone: (701) 282-2466 FAX: (701) 277-5399
North Dakota	Grand Forks	Cummins NPower, LLC 4728 Gateway Drive Grand Forks, ND 58201 Telephone: (701) 775-8197 FAX: (701) 775-4833
North Dakota	Minot	Cummins NPower, LLC 1501 - 20th Avenue, S.E. Minot, ND 58701 Telephone: (701) 852-3585 FAX: (701) 852-3588
Ohio	Columbus	Cummins Bridgeway, LLC 4000 Lyman Drive Hilliard (Columbus), OH 43026 Telephone: (614) 771-1000 FAX: (614) 771-0769
Ohio	Cincinnati	Cummins Interstate Power, Inc. 10470 Evendale Drive Cincinnati, OH 45241 Telephone: (513) 563-6670 FAX: (513) 563-0594
Ohio	Cleveland	Cummins Bridgeway, LLC 7585 Northfield Road Cleveland, OH 44146 Telephone: (440) 439-6800 FAX: (440) (440) 439-2131 Toll Free: (800) 243-6885

Ohio	Toledo	Cummins Bridgeway, LLC 801 Illinois Avenue Maumee , OH 43537 Telephone: (419) 893-8711 FAX: (419) 893-5362
Ohio	Youngstown	Cummins Bridgeway, LLC 7145 Masury Road Hubbard (Youngstown), OH 44425 Telephone: (216) 534-1935 FAX: (216) 534-5606
Oklahoma	Oklahoma City	Cummins Southern Plains ,Ltd. 5800 West Reno Oklahoma City, OK 73127 Telephone: (405) 946-4481 (24 hours) FAX: (405) 946-3336
Oklahoma	Tulsa	Cummins Southern Plains, Ltd. 16525 East Skelly Drive Tulsa, OK 74116 Telephone: (918) 234-3240 FAX: (918) 234-2342
Oregon	Coburg/Eugene	Cummins Northwest, Inc. 91201 Industrial Parkway Coburg, OR 97401 (Telephone: (541) 687-0000 FAX: (541) 687-1977 Toll Free Telephone (800)777-0336
Oregon	Medford	Cummins Northwest, Inc. 4045 Crater Lake Highway Medford, OR 97504-9796 Telephone: (541) 779-0151 FAX: (541) 772-2395 Toll Free Telephone (800)826-9414
Oregon	Pendleton	Cummins Northwest, Inc. 223 S.W. 23rd Street Pendleton, OR 97801-1810 Telephone: (541) 276-2561 FAX: (541) 276-2564 Toll Free Telephone (800)666-2561
Oregon	Portland	Cummins Northwest, Inc. 4711 N. Basin Avenue Portland, OR 97217-3557 Telephone: (503)286-5938 FAX: (503)286-5938 Toll Free Telephone: ((800)283-0336 FAX: (503)240-5553
Pennsylvania	Philadelphia	Cummins Power Systems, Inc. 2727 Ford Road Bristol, PA 19007 Telephone: (215) 785-6005 FAX: (215) 785-4085

Pennsylvania	Pittsburgh	Cummins Power Systems, Inc. 3 Alpha Drive Pittsburgh, PA 15138-2901 Telephone: (412) 820-8300 FAX: (412) 820-8308
Pennsylvania	Harrisburg	Cummins Power Systems, Inc. 4499 Lewis Road Harrisburg, PA 17111-2541 Telephone: (717) 564-1344 FAX: (717) 558-8217
Puerto Rico		Cummins de Puerto Rico, Inc. Calle 1 G1 Urb. Industrial, Barrio Palmas Cataño ZIP / Postal Code: 00962 Puerto Rico Telephone: (787) 275-2000 FAX: (787) 275-2030
South Carolina	Charleston	Cummins Atlantic Inc. 231 Farmington Road Charleston, SC 29483 Telephone: (843) 851-9819 FAX: (843) 875-4338
South Carolina	Columbia	Cummins Atlantic, Inc. 2791 Shop Road Ext Columbia, South Carolina 29209 Telephone: (803) 799-2410 FAX: (803) 779-3427
South Dakota	Sioux Falls	Cummins Central Power, LLC 701 East 54th Street North Sioux Falls, SD 57104 Telephone: (605) 336-1715 FAX: (605) 336-1748
Tennessee	Memphis	Cummins Mid-South, LLC 670 Riverside Drive Memphis, TN 38173 Telephone: (901) 577-0600 FAX: (901) 522-8758
Tennessee	Chattanooga	Cummins South, Inc. 1509 East 26th Street Chattanooga, TN 37407-1095 Telephone: (423) 629-1447 FAX: (423) 629-1494
Tennessee	Knoxville	Cummins Cumberland, Inc. 1211 Ault Road Knoxville, TN 37914 Telephone: (423) 523-0446 FAX: (423) 523-0343
Tennessee	Memphis	Cummins Mid-South, LLC 1784 E. Brooks Road Memphis, TN 38116 Telephone: (901) 577-0666 FAX: (901) 522-8758

Tennessee	Nashville	Cummins Cumberland, Inc. 706 Spence Lane Nashville, TN 37217 Telephone: (615) 366-4341 FAX: (615) 366-5693
Texas	Arlington	Cummins Southern Plains, Ltd. 600 N Watson Road Arlington, TX 76004-76011 Telephone: (817) 640-6801 FAX: (817) 640-6852
Texas	Amarillo	Cummins Southern Plains, Ltd. 5224 Interstate 40 - Expressway East Amarillo, TX 79120-1570 Telephone: (806) 373-3793 (24 hours) FAX: (806) 372-8547
Texas	Dallas	Cummins Southern Plains, Ltd. 3707 Irving Boulevard Dallas, TX 75247 Telephone: (214) 631-6400 (24 hours) FAX: (214) 631-2322
Texas	El Paso	Cummins Rocky Mountain, LLC 14333 Gateway West El Paso, TX 79927 Telephone: (915) 852-4200 FAX: (915) 852-3295
Texas	Fort Worth	Cummins Southern Plains, Ltd. 3250 North Freeway Fort Worth, TX 76111 Telephone: (817) 624-2107 (24 hours) FAX: (817) 624-3296
Texas	Houston	Cummins Southern Plains, Ltd. 7045 North Loop East Houston, Texas 77028 Telephone: (713) 679-2220 FAX: (713) 679-7774
Texas	Mesquite	Cummins Southern Plains, Ltd. 2615 Big Town Blvd. Mesquite, TX 75150 Telephone: (214) 321-5555 (24 hours) FAX: (214) 328-2732
Texas	Odessa	Cummins Southern Plains, Ltd. 1210 South Grandview P.O. Box 633 Odessa, Texas 79761 Telephone: (915) 332-9121 (24 hours) FAX: (915) 333-4655
Texas	San Antonio	Cummins Southern Plains, Ltd. 6226 Pan Am Expressway North San Antonio, TX 78218-0385 Telephone: (512) 655-5420 (24 hours) FAX: (512) 655-3865

Utah	Salt Lake City	Cummins Rocky Mountain, LLC 1030 South 300 West Salt Lake City, UT 84101 Telephone: (801) 524-1321 FAX: (801) 524-1351
Virginia		
Virginia	Richmond	Cummins Atlantic, Inc. 3900 Deepwater Terminal Road Richmond, VA 23234 Telephone: (804) 232-7891 FAX: (804) 232-7428
Virginia	Tidewater	Cummins Atlantic, Inc. 3729 Holland Blvd. Chesapeake, VA 23323 Telephone: (757) 485-4848 FAX: (757) 485-5085
Washington	Seattle	Cummins Northwest, Inc. 811 S.W. Grady Way Renton, WA 98055 Telephone: (425) 235-3400 FAX: (425) 235-8202 Toll Free: (800) 274-0336
Washington	Chehalis	Cummins Northwest, Inc. 926 N.W. Maryland Chehalis, WA 98532-0339 Telephone: (360) 748-8841 FAX: (360) 748-8843 Toll Free: (800) 451-5506
Washington	Spokane	Cummins Northwest, Inc. 11134 W. Westbow Blvd. Spokane, WA 99204 Telephone: (509) 455-4411 FAX: (509) 624-4681 Toll Free: (800) 825-2122
Washington	Tacoma	Cummins Northwest, Inc. 3701 Pacific Highway East Tacoma, WA 98424-1135 Telephone: (253) 922-2191 FAX: (253) 922-2379
Washington	Yakima	Cummins Northwest, Inc. 1905 East Central Avenue Yakima, WA 98901 Telephone: (509) 248-9033 FAX: (509) 248-9035 Toll Free: (800) 688-9033
West Virginia	Charleston	Cummins Cumberland, Inc. 3100 MacCorkle Ave. SW P.O. Box 8456 South Charleston, WV 25303 Telephone: (304) 744-6373 FAX: (304) 744-8605

West Virginia	Fairmont	Cummins Cumberland, Inc. Rt 73 So. 145 Middletown Rd Fairmont, WV 26554 Telephone: (304) 367-0196 FAX: (304) 367-1077
Wisconsin	DePere	Cummins NPower, LLC Corporate Office 875 Lawrence Drive DePere, WI 54115-5070 Telephone: (920) 337-1991 FAX: (920) 337-9746
Wisconsin		Cummins NPower, LLC 939 Lawrence Dr DePere, Wisconsin 54115 Telephone: (920) 336-9631 FAX: (920) 7336-8984
Wisconsin	Eau Claire	Cummins NPower, LLC W2600 Jopke Road P. O. Box 5070 Eau Claire, Wisconsin 54701 Telephone: (715)830-0996 FAX: (715) 830-1087
Wisconsin	Milwaukee	Cummins NPower, LLC 840 West Ryan Road Oak Creek, WI 53154 Telephone: (414) 768-7400 FAX: (414) 768-9441
Wisconsin	Wausau	Cummins NPower, LLC 7815 Camp Phillips Rd Wausau, WI 54476 Telephone: (715) 359-6888 FAX: (715) 359-3744
Wyoming	Gillette	Cummins Rocky Mountain, LLC 2700 Hwy. 14 & 16 North P.O. Box 1207 (82717) Gillette, WY 82716 Telephone: (307) 682-9611 FAX: (307) 682-8242 Toll Free: (800) 773-9611
Wyoming	Rock Springs	Cummins Rocky Mountain, LLC 2000 Foothill Blvd. P.O. Box 1634 Rock Springs, WY 82901 Telephone: (307) 362-5168 FAX: (307) 362-5171

Distributors and Branches - Canada

Alberta	Edmonton	Cummins Western Canada 11751 - 181 Street Edmonton, AB T5S 2K5 Telephone: (780) 455-2151 FAX: (780) 454-9512
Alberta		Cummins Western Canada 4887 - 35th Street S.E. Calgary, Alberta T2B 3H6, Canada Telephone: (403) 569-1122 FAX: (403) 569-0027
Alberta	Hinton	Cummins Western Canada 122 Hampshire Road Hinton, Alberta T7V 1G8, Canada Telephone: (780) 865-5111 FAX: (780) 865-5714
Alberta	Lethbridge	Cummins Western Canada 4005 - 14th Ave N Lethbridge, Alberta T1H 6P6, Canada Telephone: (403) 329-6144 FAX: (403) 320-5383
British Columbia	Vancouver	Cummins Western Canada 18452 - 96th Avenue Surrey, B.C., Canada V4N 3P8 Telephone: (604) 882-5000 FAX: (604) 882-5080
British Columbia	Kamloops	Cummins Western Canada 976 Laval Crescent Kamloops, B.C. Canada V2C 5P5 Telephone: (250) 828-2388 FAX: (250) 828-6713
British Columbia	Prince George	Cummins Western Canada Prince George, B.C. V2M 6E9 Telephone: (250) 564-9111 FAX: (250) 564-5853
British Columbia	Sparwood	Cummins Western Canada 731 Douglas Fir Road Sparwood, B.C. VOB 2G0, Canada Telephone: (250) 425-0522 FAX: (250) 425-0323
New Brunswick	Fredericton	Cummins Eastern Canada, LP R.R.#1 Doak Road Fredericton, New Brunswick E3B 4X2, Canada Telephone: (506) 451-1929 FAX: (506) 451-1927
Newfoundland	St. John's	Cummins Eastern Canada, LP 122 Clyde Avenue Donovans Industrial Park Mount Pearl, Newfoundland A1N 2C2 Canada Telephone: (709) 747-0176 FAX: (709) 747-2283

Newfoundland	Wabush	Cummins Eastern Canada, LP Wabush Industrial Park Wabush, Newfoundland A0R 1B0 Telephone: (709) 282-3626 FAX: (709) 282-3108
Nova Scotia	Halifax	Cummins Eastern Canada, LP 50 Simmonds Drive Dartmouth, Nova Scotia B3B 1R3 Telephone: (902) 468-7938 FAX: (902) 468-5177
Ontario		
Ontario	Kenora	Cummins Mid-Canada Ltd. Highway 17 East P.O. Box 8 Kenora, Ontario P9N 3X1 Telephone: (807) 548-1941 FAX: (807) 548-8302
Ontario	Ottawa	Cummins Eastern Canada, LP 3189 Swansea Crescent Ottawa, Ontario K1G 3W5, Telephone: (613) 736-1146 FAX: (613) 736-1202
Ontario	Thunder Bay	Cummins Eastern Canada, LP 1400 W. Walsh Street Thunder Bay Ontario P7E 4X4 Telephone: (807) 577-7561 FAX: (807) 577-1727
Quebec	Dorval	Cummins, Eastern Canada, LP 580 Lepihe Dorval, Quebec H9H 1G2 Telephone: (514) 631-5000 FAX: (514) 631-0104
Quebec	Quebec City	Cummins Eastern Canada, LP Branch of Cummins Americas, Inc. 2400 Watt Street Ste Foy, Quebec G1P 3T3 Canada Telephone: (418) 651-2911 FAX: (418)651-0965
Quebec	Val D'Or	Cummins, Eastern Canada, LP Val D'Or, Quebec J9P 4P6 Telephone: (514) 695-8410 FAX: (514) 695-8917
Saskatchewan	Lloydminster	Cummins Western Canada 3709 - 44th Street Lloydminster, SK S9V 0Y9 Telephone: (305) 825-2062 FAX: (305) 825-6702
Saskatchewan	Regina	Cummins Western Canada 110 Kress Street Regina, SK S4P 2Z5 Telephone: (306) 721-9710 FAX: (306) 721-2962

Saskatchewan	Saskatoon	Cummins Western Canada 3001 Faithful Avenue Saskatoon, SK S7K 4R4, Canada Telephone: (306) 933-4022 FAX: (306) 242-1722
---------------------	------------------	---



Distributors and Branches - Australia

Branches:	Gepps Cross	Cummins Engine Company, Pty. Ltd. P.O. Box 108 Blair Athol, 5084 South Australia, Australia Location: 45-49 Cavan Road Gepps Cross, 5094 Telephone: (61-8) 8262-5211
Branches:	Dosra	Cummins Engine Company, Pty. Ltd. P.O. Box 124 Darra, 4076 Queensland, Australia Location: 33 Kimberley Street Darra, 4076, Australia Telephone: (61-7) 3375-3277
Branches:	Bunbury	Cummins Engine Company, Pty. Ltd. P.O. Box 1751 Bunbury, WA 6230 Australia Location: 11 Dryanda Court Picton, WA 6230 Telephone: (61-8) 9725-6777 FAX: (61-8) 9725-6444
Branches:	Cairns	Cummins Engine Company, Pty. Ltd. P.O. Box 7189 Cairns Mail Centre, 4870 Queensland, Australia Location: Liberty Street Cairns, 4870 Telephone: (61-7) 935-2999
Branches:	Campbellfield	Cummins Engine Company, Pty. Ltd. Private Bag 9 Campbellfield, 3061 Victoria, Australia Location: 1788-1800 Hume Highway Campbellfield, 3061 Telephone: (613) 9357-9200
Branches:	Dandenong	Cummins Engine Company, Pty. Ltd. Lot 7 Greens Road Dandenong, 3175 Victoria, Australia Telephone: (613) 9706-8088
Branches:	Darwin	Cummins Engine Company, Pty. Ltd. P.O. Box 37587 Winnellie, 0821 Northern Territory, Australia Location: Lot 1758 Graffin Crescent Winnellie, 0821 Telephone: (61-8) 8947-0766

Branches:	Devonport	Cummins Engine Company, Pty. Ltd. P.O. Box 72E Tasmania, Australia Location: 2 Matthews Way Devonport, 7310 Telephone: (61-3) 6424-8800
Branches:	Emerald	Cummins Engine Company, Pty. Ltd. P.O. Box 668 Emerald, 4720 Queensland, Australia Location: Capricorn Highway Emerald, 4720 Telephone: (61-7) 4982-4022
Branches:	Grafton	Cummins Engine Company, Pty. Ltd. P.O. Box 18 South Grafton, 2461 New South Wales, Australia Location: 18-20 Induna Street South Grafton, 2461 Telephone: (61-2) 6642-3655
Branches:	Hexham	Cummins Engine Company, Pty. Ltd. 21 Gallegan Street Hexham New South Wales, Australia Telephone: (61-2) 4964-8466 FAX: (61-2) 4964-8616
Branches:	Kalgoorlie	Cummins Engine Company, Pty. Ltd. P.O. Box 706 Kalgoorlie, 6430 Western Australia, Australia Location: 16 Atbara Street Kalgoorlie, 6430 Telephone: (61-8) 9021-2588
Branches:	Karratha	Cummins Engine Company, Pty. Ltd. P.O. Box 377 Karratha, WA 6714 Australia Location: 1490 Lambert Road Karratha, WA 6714 Australia Telephone: (61-8) 9144-4646 FAX: (61-8) 9143-1507
Branches:	Laverton	Cummins Engine Company, Pty. Ltd. Locked Bag 1 Laverton, Victoria 3028 Australia Location: 195 Boundary Road Laverton North, Victoria 3028 Australia Telephone: (61-3) 9360-0800 FAX: (61-3) 9360-0438

Branches:	Leeton	Cummins Engine Company, Pty. Ltd. P.O. Box 775 Leeton, NSW 2705 Australia Location: 29 Brady Way Leeton, NSW 2705 Australia Telephone: (61-2) 6953-3077 FAX: (61-2) 6953-3109
Branches:	Mackay	Cummins Engine Company, Pty. Ltd. P.O. Box 842 Mackay, 4740 Queensland, Australia Location: 4 Presto Avenue Mackay, 4746 Telephone: (61-7) 4955-1222
Branches:	Mount Gambier	Cummins Engine Company, Pty. Ltd. P.O. Box 2219 Mount Gambier, 5290 South Australia, Australia Location: 2 Avey Road Mount Gambier, 5290 Telephone: (61-87) 25-6422
Branches:	Penrith	Cummins Engine Company, Pty. Ltd. P.O. Box 132 Cambridge Park, 2747 New South Wales, Australia Location: 7 Andrews Road Penrith, 2750 Telephone: (61-2) 4729-1313
Branches:	Queanbeyan	Cummins Engine Company, Pty. Ltd. P.O. Box 527 Queanbeyan, 2620 New South Wales, Australia Location: 15-27 Bayldon Road Queanbeyan, 2620 Telephone: (61-2) 6297-3433 FAX: (61-2) 6297-6709
Branches:	Regency Park	Cummins Engine Company, Pty. Ltd. P.O. Box 2147 Regency Park, SA 5942 Australia Location: 11 Manton Street Hindmarsh, SA 5942 Australia Telephone: (61-8) 8346-3832 FAX: (61-8) 8340-2045

Branches:	Swan Hill	Cummins Engine Company, Pty. Ltd. P.O. Box 1264 Swan Hill, 3585 Victoria, Australia Location: 5 McAllister Road Swan Hill, 3585 Telephone: (61-3) 5032-1511
Branches:	Tamworth	Cummins Engine Company, Pty. Ltd. P.O. Box 677 Tamworth, 2320 New South Wales, Australia Location: Lot 65 Gunnedah Road Tamworth, 2340 Telephone: (61-2) 6765-5455
Branches:	Townsville	Cummins Engine Company, Pty. Ltd. P.O. Box 7339 Garbutt Business Centre, QLD4814 Australia Location: 704-710 Ingham Road Townsville, QLD 4814 Telephone: (61-7) 4774-7733 FAX: (61-7) 4774-7640
Branches:	Welshpool	Cummins Engine Company, Pty. Ltd. P. O. Box 52 Welshpool, 6986 Western Australia, Australia Location: 50 Kewdale Road Welshpool, 6106 Telephone: (61-8) 9458-5911
Branches:	Wetherill Park	Cummins Engine Company, Pty. Ltd. Private Bag 150 Wetherill Park, NSW 2164 Australia Location: 492-494 Victoria Street Wetherill Park, NSW 2164 Australia Telephone: (61-2) 9616-5300 FAX: (61-2) 9616-5399
Branches:	Wodonga	Cummins Engine Company, Pty. Ltd. P.O. Box 174 Wodonga, 3690 Victoria, Australia Location: 9-11 McKoy Street Wodonga, 3690 Telephone: (61-2) 6024-3655

Distributors and Branches - New Zealand

Auckland		Cummins Engine Company, Pty. Ltd. Private Bag 92804 Penrose, Auckland, New Zealand Location: 440 Church Street Penrose Telephone: (64-9) 579-0085
Branches:	Auckland	Cummins Engine Company, Pty. Ltd. Private Bag 92804 Penrose, Auckland, New Zealand Location: 440 Church Street Penrose Telephone: (64-9) 579-0085
Branches:	Christchurch	Cummins Engine Company, Pty. Ltd. P.O. Box 16-149 Hornby, Christchurch, New Zealand Location: 35 Parkhouse Road Sockburn, Christchurch Telephone: (64-3) 348-8170
Branches:	Dunedin	Cummins Engine Company, Pty. Ltd. P.O. Box 2333 South Dunedin, New Zealand Location: 8 Devon Street Dunedin Telephone: (643) 477-8818
Branches:	Palmerston North	Cummins Engine Company, Pty. Ltd. P.O. Box 9024 Palmerston North, New Zealand Location: 852-860 Tremaine Avenue Telephone: (64-6) 356-2209
Branches:	Rotorua	Cummins Engine Company, Pty. Ltd. P.O. Box 934 Rotorua, New Zealand Location: 328 Te Ngae Road Rotorua Telephone: (647) 345-6699

Regional Offices - International - Locations

Regional Office - Daventry	
<p>Cummins Engine Co. Ltd (Serving Czech Republic), (Middle East), (Africa) Royal Oak Way South Daventry, Northamptonshire ZIP / Postal Code: NN11 8NU Brussels Telephone: (44-1327) 886 000 Fax: (44-1327) 886 100</p>	
<p>Region Countries Covered:</p>	<p>Africa Burkina Faso Cameroon Chad Congo (People's Republic) Djibouti Eritrea Gabon Ghana Guinea-Bissau Liberia Mali Mauritania Niger Rwanda Senegal Somalia Tunisia Cape Verde</p>
<p>Region Countries Covered:</p>	<p>Burundi Central African Republic Congo (Democratic Republic), Cote d'Ivoire (Ivory Coast) Equatorial Guinea, Ethiopia Gambia Guinea Kenya Libya Malta Morocco Nigeria Sao Tome & Principe Sierra Leone Togo Uganda</p>
<p>Region Countries Covered:</p>	<p>Czech Republic Austria Hungary Poland</p>
<p>Region Countries Covered:</p>	<p>Middle East Afghanistan Cyprus Iran Jordan Lebanon Pakistan Republic of Yemen Sudan Turkey Bahrain Egypt Iraq Kuwait Oman Qatar Saudi Arabia Syria United Arab Emirates</p>

Cumbrasa Regional Office - Brazil	
<p>Cummins Brasil Ltda. Rua Jati, 266 07180-900 Guarulhos Sao Paulo, Brazil Telephone: (55-11) 6465-9811 Fax: (55-11) 6412-1483</p>	
<p>Country Covered:</p>	<p>Brazil</p>

Beijing Regional Office - China	
Cummins Corporation Beijing Branch (CCBJ) 28, Tower A, Gateway, 18, Xiaguangli North Road, East Third Ring Chaoyang District Beijing 100027 People's Republic of China Telephone: (86-10) 84548888 Fax: (86-10) 6462-0226	
Countries Covered: <ul style="list-style-type: none"> China Hong Kong S.A.R Mongolia Taiwan 	
Gross-Gerau Regional Office - Germany	
Cummins Diesel Deutschland GmbH Odenwaldstr. 23 Groß-Gerau 64521 Germany Telephone: (49-6152) 174-0 Fax: (49-6152) 174-141	
Countries Covered: <ul style="list-style-type: none"> Germany Switzerland 	
Cummins India Ltd.	
Kothrud Pune, Maharashtra ZIP / Postal Code: 411029 India Telephone: (91-20) 2538-5435 / 0240 / 1105 Fax: (91-20) 2538-0125	
Countries Covered: <ul style="list-style-type: none"> Bhutan India Nepal 	
Tokyo Regional Office - Japan	
Cummins Japan Ltd. 2nd Floor, Ichiboshi Shiba Bldg 2-14, Shiba 2-chome Minato, Tokyo ZIP / Postal Code: 105-0014 Japan Telephone: (81-3) 5444-7600 Fax: (81-3) 5444-0530	
Country Covered: <ul style="list-style-type: none"> Japan 	

Seoul Regional Office - Korea	
Cummins Korea Ltd. 25th floor, ASEM tower 159-1, Samsung-Dong Kangnam-ku, Seou ZIP / Postal Code: 135-798 South Korea Telephone: (82-2) 3420-0901 Fax: (82-2) 3452-4113 / 539-6569	
Country Covered: South Korea	

Col. Polanco Regional Office - Mexico	
Cummins, S. de R.L. de C.V. Arquimedes No. 209 Col. Polanco 4605 Modern Lane Mexico, Distrito Federal ZIP / Postal Code: 11560 Mexico Telephone: (52-5) 254-3822 / 3783 / 3622 Fax: (52-5) 254-3645	
Country Covered: Mexico, Guatemala, Honduras, Costa Rica, Nicaragua, Panama	

Moscow Regional Office - Russia	
Cummins Engine Co., Inc. Park Place Office E708 113/1 Leninsky Prospect Russia 117198 Telephone: (7-495) 956-51-22 / 23 Fax: (7-495) 956-53-62	
Countries Covered: Armenia, Azerbaijan, Belarus, Tajikistan, Georgia, Kyrgyzstan, Kazakhstan, Moldova, Russia, Turkmenistan, Ukraine, Uzbekistan	

Southeast Asia Regional Office - Singapore Singapore																						
<p>Cummins Diesel Sales Corporation 8 Tanjong Penjuru ZIP / Postal Code: 609019 Singapore Telephone: (65) 265-0155 Fax - Parts/MIS/Shipping: (65) 6264-0664</p>																						
<p>Countries Covered:</p> <table style="width: 100%; border: none;"> <tr> <td style="width: 33%;">Bangladesh</td> <td style="width: 33%;">Malaysia</td> <td style="width: 33%;"></td> </tr> <tr> <td>Brunei</td> <td></td> <td></td> </tr> <tr> <td>Cambodia</td> <td>Philippines</td> <td></td> </tr> <tr> <td>Indonesia</td> <td>Singapore</td> <td></td> </tr> <tr> <td>Laos</td> <td>Sri Lanka</td> <td></td> </tr> <tr> <td></td> <td>Thailand</td> <td></td> </tr> <tr> <td></td> <td>Vietnam</td> <td></td> </tr> </table>		Bangladesh	Malaysia		Brunei			Cambodia	Philippines		Indonesia	Singapore		Laos	Sri Lanka			Thailand			Vietnam	
Bangladesh	Malaysia																					
Brunei																						
Cambodia	Philippines																					
Indonesia	Singapore																					
Laos	Sri Lanka																					
	Thailand																					
	Vietnam																					

Latin America Regional Office - Miramar (U.S.A.)																															
<p>Cummins Americas, Inc. 3350 SW 148 Avenue Suite 205 Miramar, FL 33027 U.S.A. Telephone: (954) 431-5511 Fax: (954) 433-5797</p>																															
<p>Countries Covered:</p> <table style="width: 100%; border: none;"> <tr> <td style="width: 33%;">Argentina</td> <td style="width: 33%;"></td> <td style="width: 33%;"></td> </tr> <tr> <td>Bolivia</td> <td></td> <td></td> </tr> <tr> <td>Chile</td> <td></td> <td></td> </tr> <tr> <td>Colombia</td> <td></td> <td></td> </tr> <tr> <td>Dominican Republic</td> <td>Paraguay</td> <td></td> </tr> <tr> <td>El Salvador</td> <td>Peru</td> <td></td> </tr> <tr> <td>Ecuador</td> <td>Uruguay</td> <td></td> </tr> <tr> <td>Costa Rica</td> <td>Venezuela</td> <td></td> </tr> <tr> <td>Dominican</td> <td>Honduras</td> <td></td> </tr> <tr> <td></td> <td>Nicaragua</td> <td></td> </tr> </table>		Argentina			Bolivia			Chile			Colombia			Dominican Republic	Paraguay		El Salvador	Peru		Ecuador	Uruguay		Costa Rica	Venezuela		Dominican	Honduras			Nicaragua	
Argentina																															
Bolivia																															
Chile																															
Colombia																															
Dominican Republic	Paraguay																														
El Salvador	Peru																														
Ecuador	Uruguay																														
Costa Rica	Venezuela																														
Dominican	Honduras																														
	Nicaragua																														

Distributors - International - Locations

Cummins Middle East FZE	Cummins Middle East FZE	P.O. Box No 17636, Units ZF 05 & 06 Jebel Ali Free Zone, Dubai United Arab Emirates Telephone: 00 9714 8838998 Fax: 00 9714 8838997
United Arab Emirates	Cummins Emirates Sales & Service LLC	P.O. Box No 54044 Al Quoz Industrial Estate, Dubai United Arab Emirates Telephone: 00 9714 3478184 Fax: 00 9714 3478185 Toll Free: 800 4184
United Arab Emirates	Cummins Emirates Sales & Service LLC	P.O. Box No 70242, Abu Dhabi United Arab Emirates Telephone: 00 9712 6722980 Fax: 00 9712 6722981
ALBANIA		(Please contact the Central & Eastern European Regional Office) Cummins Diesel Deutschland GmbHGross-Gerau Odenwaldstraße 23 Groß-Gerau ZIP / Postal Code: 64521 Germany Telephone: (49-6152) 174-0 Fax: (49-6152) 174-141
ALGERIA		(Please contact) Cummins Diesel S.A. 39 rue Ampère BP 190 Chassieu cédex 69680 France Telephone: (33-4) 72 22 92 72 Fax: (33-4) 78 90 19 56
ALGERIA		-See SOUTH PACIFIC ISLANDS (Please contact) Cummins 2 Caribbean Drive Scoresby 3179 Victoria AUSTRALIA Telephone: (61-3) 9765-3222 Fax: (61-3) 9763-0079
ANDORRA		- See European Regional Office - Mechelen
ANDORRA		Cummins Belgium Egide Walschaertsstraat, 2 Industriepark Zuid 2800 Mechelen Belgium Europe Telephone: (32-15) 47 91 00 Fax: (32-15) 27 56 86
ANDORRA		

ANGOLA	(Please contact) Cummins Diesel South Africa (Pty) Ltd	13 Eastern Service Road Kelvin (Neighbourhood), Alexandra Rua Major Kahangulo, 134/140 Gauteng, South Africa ZIP / Postal Code: 2054 South Africa Telephone: (27-11) 321 8700 Fax: (27-11) 444 2012
ANTIGUA		Miami (Office In U.S.A.) Cummins Power South, LLC 9900 N.W. 77 Ave. Hialeah Gardens, FL 33016 Telephone: (305) 821-4200 Fax: (305) 557-2992
ARGENTINA	Buenos Aires	Distribuidora Cummins, S.A. Ruta Panamericana KM 32.5 El Talar de Pacheco, Buenos Aires ZIP / Postal Code: CP 1618 Argentina Telephone: (54-11) 4736-6400 Fax: (54-11) 4736-6479 / 6466
ARUBA, ISLAND OF		(Please contact) Cummins Power South, LLC 9900 N W 77th Ave. Hialeah Gardens, Florida 33016 Telephone: (1-305) 821-4200 Fax: (1-305) 557-2992
AUSTRALIA	Bunbury	Cummins 11 Dryanda Court Picton Bunbury, Western Australia 6229 Telephone: (61-8) 9725-6777 Fax: (61-8) 9725-6444
AUSTRALIA	Cairns	Cummins 11 Liberty Street Cairns, Queensland 4870 Australia Telephone: (61-7) 935-2999 Fax: (61-7) 4035 2909
AUSTRALIA	Campbellfield	Cummins 1788-1800 Hume Highway Campbellfield, Victoria 3061 Australia Telephone: (613) 9357-9200 Fax: (613) 9357 9916
AUSTRALIA	Dandenong	Cummins 46 Greens Road Dandenong, Victoria 3175 Australia Telephone: (613) 9706-8088 Fax: (613) 9706 8016
AUSTRALIA	Darwin	Cummins Lot 1758 Graffin Crescent Winnellie, Darwin Northern Territory 0820 Australia Telephone: (61-8) 8947-0766 Fax: (61-8) 8984 4569

AUSTRALIA	Devonport	Cummins 2 Matthews Way Devonport, Tasmania 7310 Australia Telephone: (61-3) 6424-8800 Fax: (61-3) 6424 2200
AUSTRALIA	Emerald	Cummins 23 Old Sheeppark Place Emerald, Queensland 4720 Australia Telephone: (61-7) 4982 4022 Fax: (61-7) 4982 4159
AUSTRALIA	Grafton	Cummins 18 - 20 Induna Street South Grafton, New South Wales 2460 Australia Telephone: (61-2) 6641 1000 Fax: (61-2) 6641 1099
AUSTRALIA	Hexham	Cummins Engine Company, Pty. Ltd. 21 Galleghan Street Hexham Newcastle, New South Wales, Australia 2322 Telephone: (61-2) 4964-8466 Fax: (61-2) 4964-8616
AUSTRALIA	Kalgoorlie	Cummins Lot 62 Great Eastern Highway Cnr Hunter Street Kalgoorlie, Western Australia ZIP / Postal Code: 6430 Australia Telephone: (61-8) 9080 1300 Fax: (61-8) 9091 7933
AUSTRALIA	Karratha	Cummins 1964 Anderson Road Karratha, Western Australia 6714 Australia Telephone: (61-8) 9144 4646 Fax: (61-8) 9143 1507
AUSTRALIA	Laverton	Cummins 191-195 Boundary Road Laverton North, Victoria 3026 Australia Telephone: (61-3) 8368 0800 Fax: (61-3) 9360 0438
AUSTRALIA	Leeton	Cummins 29 Brady Way Leeton, NSW 2705 Australia Telephone: (61-2) 6953-3077 Fax: (61-2) 6953-3109

AUSTRALIA	Mackay	Cummins 46 Southgate Drive Paget, Queensland ZIP / Postal Code: 4740 Australia Telephone: (61-7) 4952 8100 Fax: (61-7) 4952 5631
AUSTRALIA	Mount Gambier	Cummins 2 Avey Road Mount Gambier, South Australia 5290 Australia Telephone: (61-8) 8725 6422 Fax: (61-8) 8724 9764
AUSTRALIA	Penrith	Cummins Total Truck Centre 141 Coreen Avenue Penrith, New South Wales 2750 Australia Telephone: (61-2) 4731 2188 Fax: (61-2) 4731 1140
AUSTRALIA	Queanbeyan	Cummins 15-17 Bayldon Road Queanbeyan, New South Wales 2620 Australia Telephone: (61-2) 6297 3433 Fax: (61-2) 6297 6709
AUSTRALIA	Swan Hill	Cummins 5 McAllister Road Swan Hill, Victoria 3585 Australia Telephone: (61-3) 5033 1511 Fax: (61-3) 5032 9662
AUSTRALIA	Tamworth	Cummins Lot 65 Gunnedah Road Tamworth, New South Wales 2340 Australia Telephone: (61-2) 6765 5455 Fax: (61-2) 6765 5443
AUSTRALIA	Townsville	Cummins 704-710 Ingham Road Townsville, Queensland 4810 Australia Telephone: (61-7) 4774 7733 Fax: (61-7) 4774 7640
AUSTRALIA	Welshpool	Cummins 443 Horrie Miller Drive Industrial Park Perth International Airport, Western Australia 6105 Australia Telephone: (61-7) 9475 8777 Fax: (61-7) 9475 8666
AUSTRALIA	Wetherill Park	Cummins 492-494 Victoria Street Wetherill Park, New South Wales 2164 Australia Telephone: (61-2) 9616 5300 Fax: (61-2) 9616 5399

AUSTRALIA	Wodonga	Cummins 9 - 11 McKoy Street Wodonga, Victoria 3690 Australia Telephone: (61-2) 6024 3655 Fax: (61-2) 6024 3102
AUSTRIA	Neudörfel	Cummins Bickfordstraße 25 Neudörfel, Burgenland 7201 Austria Telephone: (43-2622) 77418 0 Fax: (43-2622) 77418 4
BAHAMAS	Miami (Office in U.S.A.)	Cummins Power South, LLC 9900 N W 77th Ave. Hialeah Gardens, FL 33016 Telephone: (305) 821-4200 Fax: (305) 557-2992
BAHRAIN	Bahrain	Yusuf Bin Ahmed Kanoo W.L.L. Commercial Division 832 Majlees Al Tawoon Highway, Al-Hamriya 611, Sitra Manama ZIP / Postal Code: Kingdom of Bahrain Bahrain Telephone: (973) 17 738200 Fax: (973) 17 732828
BALEARIC ISLANDS	Madrid (Office in Spain)	Cummins Ventas y Servicio, S.A. Torrelaguna, 56 Madrid 28027 Spain Telephone: (34-91) 367-2000 376-2404 Fax: (34-91) 407 6604
BANGLADESH	MIR Trading Co.	House #55/1, Road # 8/A Dhamondi R/A Dhaka 1205 Bangladesh Telephone: (880-2) 8959425-7, 8960680-1, 8960643 Fax: (880-2) 8961373
BARBADOS	Miami (Office in U.S.A.)	Cummins Power South, LLC 900 N W 77th Ave. Hialeah Gardens, Florida 33016 Telephone: (305) 821-821-4200 Fax: (305) 557-2992
BELGIUM	Mechelen	Cummins Distributor Egide Walschaertsstraat, 2 Industriepark Zuid Mechelen ZIP / Postal Code: 2800Belgium Telephone: (32-15) 479 100 Fax: (32-15) 275 686
BELIZE	Tampa (Office in U.S.A.)	Cummins Power South, LLC 5421 N. 59th Street Tampa, FL 33610 Telephone: (813) 621-7202 Fax: (813) 621-8250

BENIN		- See Togo
BENIN	TOGOMAT s.a.	Zone Industrielle CNPPME Lome Togo Telephone: (228) 2272395 Fax: (228) 2270310
BERMUDA	Bronx (Office in U.S.A.)	Cummins Metropower, Inc. 890 Zerega Avenue Bronx, NY 10473 Telephone: (718) 892-2400 Fax: (718) 892-0055
BHUTAN	Pune (Office in India)	Cummins Diesel Sales & Service (India) Ltd 35A/1/2, Erandawana Pune, Maharashtra 411038 India Telephone: (91-20) 25431234 / 25430666 25431703 Fax: (91-20) 25439490
BOTSWANA - See Southern Africa Regional Office - Kelvin	Cummins Diesel South Africa (Pty)	9 Impala Road Kelvin (Neighbourhood), Alexandra Gauteng, South Africa 2054 South Africa Telephone: (27-11) 321 8800 Fax: (27-11) 444 3254
BRAZIL	Belo Horizonte	Distribuidora Cummins Minas Ltda. Anel Rodoviario, Km 01 - Bairro Olhos D'Agua Norte Belo Horizonte, Minas Gerais 31950 Brazil Telephone: (55-31) 3288-1344 Fax: (55-31) 3288-1141
BRAZIL	Campo Grande	Cummins Distribuidora de Motores Diesel e Equipamentos Ltda. Av. Rod. BR 163, nr. 5185 Campo Grande, MATO GROSSO DO SUL 79060 Brazil Telephone: (55-67) 387-8707 Fax: (55-67) 387-8707
BRAZIL	Curitiba	Distribuidora Parana de Motores Cummins Ltda. Abel Scuisiato 3020, Bairro Atuba Curitiba, PARANA 83408 Brazil Telephone: (55-41) 3675-4500 Fax: (55-41) 3675-6077
BRAZIL	Fortaleza	Distribuidora Cummins Diesel do Nordeste Ltda BR 116, km.10 - nr.10.001, Messejana Fortaleza, CEARA ZIP / Postal Code: 60871 Brazil Telephone: (55-85) 4011-6400 Fax: (55-85) 4011-6400

BRAZIL	Goianian	Distribuidora Cummins Centro Oeste Ltda. Centro Oeste Ltda. Av. Caiapo , 777 Bairro Santa Genoveva Goiania, GOIAS 74672 Brazil Telephone: (55-62) 269-1010 / 1011 Fax: (55-62) 269-1032 / 1021
BRAZIL	Manaus	Powertech Comercial Ltda. Av. Efigenio Sales 1717 - Parque 10 Estrada da Ponta Negra, 6080 - Sao Manaus, AMAZONAS 69060 Brazil Telephone: (55-92) 642-2014 Fax: (55-92) 236-6711
BRAZIL	Porto Alegre	Distribuidora Meridional Motores Cummins Ltda. Av. Assis Brasil , 9000 Sarandi Porto Alegre, RIO GRANDE DO SUL 91140 Brazil Telephone: (55-51) 3021-2288 Fax: (55-51) 3364-2288
BRAZIL	Rio de Janeiro	Cummins Distribuidora de Motores Diesel e Equipamentos Ltda. Av. Brasil, 20289 Botafogo Rio de Janeiro, RIO DE JANEIRO 21515 Brazil Telephone: (55-21) 2196-3131 Fax: (55-21) 2196-3121
BRAZIL	Sao Paulo	Cummins Distribuidora de Motores Diesel e Equipamentos Ltda. Rua Coronel Euclides Machado, 52 Freguesia do O Sao Paulo, SAO PAULO 02713 Brazil Telephone: (55-11) 3931-2900 Fax: (55-11) 3931-2900
BRITISH VIRGIN ISLANDS		- See Puerto Rico
BRITISH VIRGIN ISLANDS	Cummins de Puerto Rico, Inc.	Calle 1 G1 Urb. Industrial, Barrio Palmas Cataño 00962 Puerto Rico Telephone: (787) 275-2000 Fax: (787) 275-2030
BRUNEI		- See Malaysia
BRUNEI	Scott & English (M) Sdn Bhd	12 Jalan U1/15, Seksyen U1 Hicom-Glenmarie Industrial Park Shah Alam, Selangor Darul Ehsan 40150 Malaysia Telephone: (60-3) 7805-1111 Fax: (60-3) 7803-5122
BURKINA - FASO		- See North/West/East and Central Africa Regional Office - Daventry

BURKINA - FASO	Cummins Engine Company Ltd	Royal Oak Way South Daventry, Northants ZIP / Postal Code: NN11 5NU United Kingdom Telephone: (44-1327) 886000 Fax: (44-1327) 886106
BULGARIA		-See Germany Regional Office - Gross-Gerau
BULGARIA	Cummins Diesel Deutschland GmbH	Odenwaldstraße 23 Groß-Gerau, Hessen 64521 Germany Telephone: (49-6152) 174-0 Fax: (49-6152) 174-141
BURMA	Kuala Lumpur (Office In Malaysia)	Scott & English (M) Sdn Bhd 12 Jalan U1/15, Seksyen U1 Hicom-Glenmarie Industrial Park Shah Alam, Selangor Darul Ehsan 40150 Malaysia Telephone: (60-3) 7805-1111 Fax: (60-3) 7803-5122
BURUNDI	Brussels (Office in Belgium)	Cummins Belgium N.V./S.A. Egide Walschaertsstraat, 2 Industriepark Zuid Mechelen 2800 Belgium Telephone: (32-15) 479 100 Fax: (32-15) 275 686
CAMBODIA		Scott & English (Cambodia) Ltd. No. 20A E0/E1 Russian Boulevard Phnom Penh Cambodia Telephone: (855-23) 723741 Fax: (855-23) 723741
CANARY ISLANDS	Madrid (Office in Spain)	Cummins Ventas y Servicio S. A. Torrelaguna 56 Madrid 28027 Spain Telephone: (34-91) 367 20 00 / 367 24 04 Fax: (34-91) 407 66 04
CAPE VERDE		- See ECV Portugal Electro Central Vulcanizadora, Lda Rua Conselheiro Martins de Carvalho Lote 1480 Restelo Lisbon ZIP / Postal Code: 1400 Portugal Telephone: (351-21) 3034800 Fax: (351-21) 3034801 / 2
CENTRAL AFRICAN REPUBLIC		- See North/West Africa Regional Office - Daventry Cummins Engine Company Ltd Royal Oak Way South Daventry, Northants NN11 5NU United Kingdom Telephone: (44-1327) 886000 Fax: (44-1327) 886106

CHAD		- See North/West/East and Central Africa Regional Office - Daventry Cummins Engine Company Ltd Royal Oak Way South Daventry, Northants NN11 5NU United Kingdom Telephone: (44-1327) 886000 Fax: (44-1327) 886106
CHILE	Santiago	Distribuidora Cummins Chile, S.A. Avda. Americo Vespucio # 0631 Santiago, Quilicura ZIP / Postal Code: 873-0596 Chile Telephone: (56-2) 655-7253 / 7245 Fax: (56-2) 655-7216 / 7436
CHINA, PEOPLE'S REPUBLIC	Beijing	Cummins Engine (Beijing) Co., Ltd. No. 8, Wan Yuan Street Beijing Economic and Technology Development Zone Beijing, 100176 People's Republic of China Telephone: (86-10) 67882258 Fax: (86-10) 67882285
CHINA, PEOPLE'S REPUBLIC	Shenyang	Cummins Engine (China) Investment Co., Ltd. ShenYang Workshop & Branch Office No.5-2 Seventh Street Shenyang Economic-Technological Development Area Shenyang, Liaoning 110141 China Telephone: (86-24) 25506611 Fax: (86-24) 25365599
CHINA, PEOPLE'S REPUBLIC	Kunming	Cummins (China) Investment Co. Ltd. Kunming Branch Room 606, Hongta Mansion No.155 Beijing Road Kunming, Yunnan 650011 Telephone: (86-871) 3579471/511/579/958 Fax: (86-871) 3579210
CHINA, PEOPLE'S REPUBLIC	Shanghai	Cummins (China) Investment Co., Ltd. Shanghai Distributor Branch No. 581, New jin Qiao Road Pu Dong New Area Shanghai, Shanghai 201206 China Telephone: (86-21) 50318966 Fax: (86-21) 50318528
CHINA, PEOPLE'S REPUBLIC	Urumqi	Cummins Engine (China) Investment Co., Ltd Urumqi Branch No.7, Shanghai Rd. Urumqi, Xinjiang 830011 China Telephone: (86-991) 3780332/5/6/7/8/9 Fax: (86-991) 3780334

CHINA, PEOPLE'S REPUBLIC	Wuhan	Cummins Engine (China) Investment Co., Ltd. Wuhan Branch No.2 Zhang Po Road, Dong Xi Hu District A-Kaili Commercial Building Wuhan, Hubei 430040 China Telephone: (86-27) 83081677 Fax: (86-27) 83259369 / 83259370
CHINA, PEOPLE'S REPUBLIC	Guangzhou	Cummins (China) Investment Co., Ltd. Guangzhou Branch G/F, Unit 1 & 2, Block 5, Xing Hui Yuan NO. 46, Jinsui Road, Zhu Jiang New City, Guangzhou, Guangdong 510623 China Telephone: (86-20) 38621009 Fax: (86-20) 38621144
CHINA, PEOPLE'S REPUBLIC	Shenzhen	Shenzhen Chongfa Cummins Engine Company Ltd. Tian An Che Gong Miao Industrial Estate, Unit F2.6 - 2D Shenzhen Shennan Da Dao Shenzhen, Guangdong 518040 China Telephone: (86-755) 83415479 Fax: (86-755) 83415480
COLOMBIA	Barranquilla	Cummins de Colombia, S.A. Calle 65 (Avenida Murillo) #6-31 Diagonal a Gran Abastos Soledad, Atlantico Colombia Telephone: (57-53) 282600 / 282601 / 282602 / 282603 / 282604 Fax: (57-53) 282640 / 282641
COLOMBIA	Bogota	Cummins de los Andes S.A. Avenida Ciudad de Cali No. 11-22 Location: Bogota, Cundinamarca Colombia Telephone: (57-1) 294-8444 Fax: (57-1) 2294-8431
COLOMBIA	Bucaramanga	Cummins API Ltda. Kilómetro 7 Vía a Girón - Zona Industrial A.A. 1821 Bucaramanga, Colombia Bucaramanga, Santander Colombia Telephone: (57-76) 468060 / 469262 / 469263 Fax: (57-76) 468065
COLOMBIA	Cali	Tecnodiesel Limitada Apartado Aereo No. 6398 Carrera 8, No. 27-43 Cali, Valle Colombia Telephone: (57-2) 442-2422 Fax: (57-2) 442-1798

COLOMBIA	Medellin	Equitel Carrera 52, # 10-184 Medellin, Antioquia Colombia Telephone: (57-4) 255-4200 Fax: (57-4) 255-4104
COLOMBIA	Pereira	Tecnodiesel Limitada Carrera 16 No. 9 - 68 Avenida Simon Bolivar, Dosquebradas Pereira, Risaralda Colombia Telephone: (57-63) 306102 Fax: (57-63) 300062
COMOROS		- See Southern Africa Regional Office - Kelvin
COMOROS		Cummins Diesel South Africa (Pty) Ltd 9 Impala Road Kelvin (Neighbourhood), Alexandra Gauteng, South Africa 2054 South Africa Telephone: (27-11) 321 8800 Fax: (27-11) 444 3254
CONGO, PEOPLE'S REPUBLIC	Mechelen (Office in Belgium)	Cummins Belgium N.V./S.A. Egide Walschaertsstraat, 2 Industriepark Zuid Mechelen 2800 Belgium Telephone: (32-15) 479 100 Fax: (32-15) 275 686
CORSICA		- See France (Please contact) Cummins Diesel S.A. 39 rue Ampère BP 190 Chassieu cédex 69680 Telephone: (33-4) 479 100 Fax: (33-4) 78 90 19 56
COSTA RICA	San Jose	Oficina Regional Cummins de Centro America Urbanización Rincón Verde Dos Casa 13E San Pablo de Heredia Costa Rica Telephone: (506) 238-1160 Fax: (506) 238-1108
CYPRUS	Nicosia	Alexander Dimitriou & Sons Limited 158 Limassol Ave Latsia Nicosia CY-2235 Cyprus Telephone: (357-22) 715 300 Fax: (357-22) 715 400

CZECH REPUBLIC		- See Central & Eastern Europe Cummins Czech Republic s.r.o. Komerční zóna Pruhonice Cestlice Obchodní 132 Praha, Prague 251 01 Czech Republic Telephone: (420-272) 680 110 Fax: (420-272) 680 090
DENMARK	Glostrup	Cummins Diesel Salg & Service A/S Hovedvejen 233B, Osted Roskilde 4000 Denmark Telephone: (45-46) 42 35 50 Fax: (45-46) 42 30 50
DJIBOUTI		- See North/West/East and Central Africa
DJIBOUTI		Cummins Engine Company Ltd Royal Oak Way South Daventry, Northants ZIP / Postal Code: NN11 5NU United Kingdom Telephone: (44-1327) 886000 Fax: (44-1327) 886106
DOMINICAN REPUBLIC	Santo Domingo	Argico C. por A. Calle Jose A. Soler No.3 Esq. Lope de Vega Santo Domingo, Distrito Nacional Dominican Republic Telephone: (809) 562-6281 Fax: (809) 562-4233
DUBAI		- See United Arab Emirates
DUBAI		Cummins Middle East FZE P.O. Box No 17636, Units ZF 05 & 06 Jebel Ali Free Zone, Dubai United Arab Emirates Telephone: (00 9714) 8838998 Fax: (00 9714) 8838997
DUBAI	United Arab Emirates	Cummins Emirates Sales & Service LLC P.O. Box No 54044 United Arab Emirates Telephone: (00 9714) 3478184 Fax: (00 9714) 3478185 Toll Free: (800) 4184
ECUADOR	Guayaquil	Indusur S.A. Ave. Carlos Julio Arosemena Km. 4 Guayaquil, Guayas Ecuador Telephone: (593-4) 220-1177 / 220-0655 Fax: (593-4) 220-1052
ECUADOR	Quito	Rectificadora Botar S.A. Av. 10 de Agosto # 5980 Quito, Pichincha Ecuador Telephone: (593-2) 2265-177 / 2265-209 / 2265-225 / 2265-193 Fax: (593-2) 2459-031

EGYPT	Cairo	Egyptian International Motors CO. Ltd (EIM) Autostrade Road Al-Mugattam, Cairo Egypt Telephone: (20-2) 5061600 / 1 / 2 Fax: (20-2) 5065620
EL SALVADOR	San Salvador	Maquinaria Salvadoreña, S.A. de C.V. Blvd. Ejercito Nacional y 54 Ave. Norte Edificio MAQSA San Salvador El Salvador El Salvador Telephone: (503) 2293-1666 Fax: (503) 2293-1656
ENGLAND		- See United Kingdom
ENGLAND		Cummins UK Rutherford Drive Park Farm South Wellingborough, Northants ZIP / Postal Code: NN8 6AN United Kingdom Telephone: (44-1933) 334200 Fax: (44-1933) 334198
EQUATORIAL GUINEA		- See North/West/East and Central Africa Regional Office - Daventry
EQUATORIAL GUINEA		Cummins Engine Company Ltd Royal Oak Way South Daventry, Northants ZIP / Postal Code: NN11 5NU United Kingdom Telephone: (44-1327) 886000 Fax: (44-1327) 886106
ESTONIA		Cummins Czech Republic s.r.o. Komerčni zona Pruhonice Cestlice Obchodni 132 Praha, Prague 251 01 Czech Republic Telephone: (420-272) 680 110 Fax: (420-272) 680 090
FAROE ISLANDS	Wellingborough (Office in United Kingdom)	Cummins UK Rutherford Drive Park Farm South Wellingborough, Northants NN8 6AN England Telephone: (44-1933) 334200 Fax: (44-1933) 334198
FERNANDO PO		- See Spain
FERNANDO PO		Cummins Ventas y Servicio S. A. Torrelaguna 56 Madrid 28027 Spain Telephone: (34-91) 367 20 00 / 367 24 04 Fax: (34-91) 407 66 04
FIJI		- See Cummins New Zealand

FIJI		Cummins 9 Langley Road Manukau City Centre, Auckland 1702 New Zealand Telephone: (64-3) 277 1000 Fax: (64-3) 277 1001
FINLAND	Helsinki	Machinery Oy Ansatie 5 Vantaa ZIP / Postal Code: FIN-01741 Finland Telephone: (358-9) 89551
FRANCE	Lyon	CUMMINS DIESEL S.A. 39 rue Ampère BP 190 Chassieu cédex 69680 France Telephone: (33-4) 72 22 92 72 Fax: (33-4) 78 90 19 56
GABON		- See North/West/East and Central Africa Regional Office - Daventry
GAMBIA		Matforce 10 Avenue Faidherbe Dakar Senegal Telephone: (221-8) 399500 Fax: (221-8) 399531 / 399550
GEORGIA		- See Moscow Regional Office - Moscow
GEORGIA		Cummins Engine Company, Inc. Park Place Office E708, 113/1 Leninskiy Prospect Moscow ZIP / Postal Code: 117198 Russia Telephone: (7-495) 956-51-22 / 23 Fax: (7-495) 956-53-62
GERMANY	Gross-Gerau	Cummins Diesel Deutschland GmbH Odenwaldstraße 23 Groß-Gerau, Hessen 64521 Germany Telephone: (49-6152) 174-0 Fax: (49-6152) 174-141
GHANA	Accra	J&D Diesels and Systems P.O. Box c2381 Cantonments Accra, Ghana Telephone: (233-21) 30-14-51 Fax: (233-21) 301 201
GREECE	Athens	ERGOTRAK Industrial Machinery & Equipment Trading Company 14 km. National Road of Athens-Lamia Kifissia 14510 Greece Telephone: (30-210) 6293400 / 41 Fax: (30-210) 6201845

GREENLAND		- See Denmark Cummins Diesel Salg & Service A/S Hovedvejen 233B, Osted Roskilde 4000 Denmark Telephone: (45-46) 42 35 50 Fax: (45-46) 42 30 50
GRENADA	Miami (Office in U.S.A.)	Cummins Power South, LLC 9900 N W 77th Ave. Hialeah Gardens, Florida 33016 Telephone: (305) 821-4200 Fax: (305) 557-2992
GUADELOUPE	Miami (Office in U.S.A.)	Cummins Power South, LLC 9900 N W 77th Ave. Hialeah Gardens, Florida 33016 Telephone: (305) 821-4200 Fax: (305) 557-2992
GUAM	Barrigada	Mid-Pac Far East, Inc. Airport Industrial Park 825 Tiyan Parkway Barrigada, Guam 96931 Telephone: (671) 632-5160 Fax: (671) 632-5186
GUATEMALA	Guatemala City	Maquinaria y Equipos, S.A. Carretera a Amatitlan, Kilómetro 12, Zona 12, Guatemala City Guatemala Guatemala Telephone: (502) 2477-2746 / 2477-2747 / 2477-2748 / 2477-2749 / 2477-2750 Fax: (502) 2477-3929
GUINEA	Mechelen (Office in Belgium)	Cummins Belgium N.V./S.A. Egide Walschaertsstraat, 2 Industriepark Zuid Mechelen 2800 Belgium Telephone: (32-15) 479 100 Fax: (32-15) 275 686
GUINEA BISSAU		- See North/West/East and Central Africa Regional Office - Daventry Cummins Engine Company Ltd Royal Oak Way South Daventry, Northants NN11 5NU United Kingdom Telephone: (44-1327) 886000 Fax: (44-1327) 886106
GUYANA	Miami (Office in U.S.A.)	Cummins Power South, LLC 9900 N.W. 77 Court Hialeah Gardens, FL 33016 Telephone: (305) 821-4200 Fax: (305) 557-2992

GUYANA, FRENCH	See France	CUMMINS DIESEL S.A. 39 rue Ampère BP 190 Chassieu cédex 69680 France Telephone: (33-4) 72 22 92 72 Fax: (33-4) 78 90 19 56
HAITI	Miami (Office in U.S.A.)	Cummins Power South, LLC 9900 N W 77th Ave. Hialeah Gardens, FL 33016 Telephone: (305) 821-4200 Fax: (305) 557-2992
HOLLAND	- See Netherlands	Cummins Holland B V Galvanistraat 35 Dordrecht, Zuid-Holland 3316 GH Netherlands Telephone: (31-78) 6181200 Fax: (31-78) 6176579
HONDURAS	Tegucigalpa	Comercial Laeisz Honduras, S.A. Desvio Colonia La Pradera, Blvd. Toncontin Tegucigalpa Honduras Telephone: (504) 233-5615 / 234-7072 Fax: (504) 233-9531 / 234-3718
HONG KONG	Kowloon	Cummins Hong Kong Ltd. 2/F Unison Industrial Centre 27-31 Au Pui Wan Street, Fo Tan, Shatin, N.T. Hong Kong, Hong Kong Hong Kong S.A.R.ong Kong Telephone: (852) 2606-5678 Fax: (852) 2691-1641
ICELAND	Velasalan H.F.	Ananastrum 1 Reykjavik 121 Iceland Telephone: (354) 5526122 Fax: (354) 580 5301
INDIA	Pune	Cummins Diesel Sales & Service (India) Ltd 35A/1/2, Erandawana Pune, Maharashtra 411038 Telephone: (91-20)25431234 , 25430666, 25431703 Fax: (91-20) 25439490
INDIA	Kolkata	Cummins Diesel Sales & Service (India) Ltd 94, Tivoli Court, 1/C Ballygunge Circular Road Kolkata, West Bengal 700019 India Telephone: (91-33) 22472481 / 22470774 / 22478065 Fax: (91-33) 22473833

INDIA	New Delhi	Cummins Diesel Sales & Service (India) Ltd. 911-912, Hemkunt Tower, 98 Nehru Place New Delhi, Delhi 110019 India Telephone: (91-11) 26431051 / 26445756 / 26445759 / 26416947 Fax: (91-11) 26212817
INDIA	Raipur	Cummins Diesel Sales & Service (India) Ltd. Vanija Bhavan' 1st Floor, Sai Nagar Fafadih Devendra Nagar Road Raipur, Madhya Pradesh 492009 India Telephone: (91-771) 2521101 / 2521102 Fax: (91-771) 2521103
INDIA	Ranchi	Cummins Diesel Sales & Service (India) Ltd. 'Shanti Kunj' C-202, Vidyalaya Marg Road No. 01, Ashok Nagar, Ranchi, Jharkhand 834002 India Telephone: (91-651) 2241948 / 2241521 Fax: (91-651) 2242815
INDONESIA	Jakarta	P.T. Alltrak 1978 J1. R.S.C. Veteran No. 4 Bintaro, Rempoa Jakarta 12330 Indonesia Telephone: (62-21) 736-1978 / 3301 / 5085 Fax: (62-21) 736-1977 / 3302
IRAQ		- See Middle East Regional Office or United Arab Emirates
IRAQ		Cummins Emirates Sales & Service LLC P.O. Box No 54044 Al Quoz Industrial Estate, Dubai United Arab Emirates Telephone: 00 9714 3478184 Fax: 00 9714 3478185 Toll Free: 800 4184
IRELAND	Wellingborough (Office in England)	Cummins UK Rutherford Drive Park Farm South Wellingborough, Northants NN8 6AN United Kingdom Telephone: (44-1933) 334200 Fax: (44-1933) 334198
ISRAEL	Tel Aviv	Israel Engines & Trailers 33 Hahashmal Street Tel Aviv 61003 Israel Telephone: (972-3) 7106222 Fax: (972-3) 5604540

ITALY	Milan	Cummins Italia S.p.A. Via Einaudi, 5 Peschiera Borromeo, Milano 20068 Italy Telephone: (39-02) 51 65 581 Fax: (39-02) 51 65 58 56
IVORY COAST		- See Cote d' Ivoire Ste. des Ets. Lemerrier et Fils 10 rue des Brasseurs Abidjan 15 Cote d'Ivoire Cote d'Ivoire Telephone: (225-21) 352522 / 350687 / 350676 Fax: (225-21) 358562 / 243938
JAMAICA		Cummins Power South, LLC 9900 N W 77th Ave. Hialeah Gardens, FL 33016 Telephone: (305) 821-4200 Fax: (305) 557-2992
JAPAN	Tokyo	Cummins Japan Ltd. 2-11, Higashi-Kojiya 6-chome Ota-ku, Tokyo 144-0033 Japan Telephone: (81-3) 5735-0600 Fax: (81-3) 5735-0605
JORDAN	Amman	SETI Jordan Ltd. Bayader Wadi Alseer Industrial Street Amman, Jordan Jordan Telephone: (962-6) 582 7300 / 4261 Fax: (962-6) 585 6854
KENYA	Nairobi	Simba Colt Motors Ltd Cummins Engine Division, PO Box 48296, Code 00100 Shimo-La-Tewa Road, Nairobi Kenya Telephone: (254-20) 650029 Fax: (254-20) 534870
KOREA - SOUTH KOREA	Seoul	Cummins Diesel Sales & Service Co., Ltd. 354-4, Chonheung-ri, Songgo-eup Chonan-city, Choongchungnam-do 330-836 South Korea Telephone: (82-41) 620-9202/3 Fax: (82-41) 621-9121 to 2
KOREA - SOUTH KOREA		Cummins Korea Ltd 2nd Floor, Choyang Bldg. 113 Samsung Dong, Kangnam-ku Seoul, Korea Telephone: (82-2) 3420-0901 Fax: (82-2) 3452-4113 / 539-6569

KUWAIT	Kuwait	General Transportation & Equipment Co. (GTE) (Sales Department) Safat 13011 Kuwait Telephone: (965) 483 3380/1/2 Fax: (965) 481 2860
LAOS		Diethelm & Co. Ltd Ban Phonsinouan, Unit 18, New Road Sisattanak District, Vientiane Laos P.D.R. Telephone: (856-21) 453 100 Fax: (856-21) 453-103
LATVIA	Please contact the Central & Eastern European Regional Office	Cummins Diesel Deutschland GmbH Odenwaldstraße 23 Groß-Gerau ZIP / Postal Code: 64521 Germany Telephone: (49-6152) 174-0 Fax: (49-6152) 174-141
LEBANON	Beirut	S.E.T.I. Charles Keller SAL Corniche du Fleuve Beirut Lebanon Lebanon Telephone: (961-1) 425040 / 425041 / 426042 Fax: (961-1) 425637 / 425389
LESOTHO	- See South Africa	Cummins Diesel South Africa (Pty) Ltd 13 Eastern Service Road Kelvin (Neighbourhood), Alexandra Gauteng, South Africa 2054 South Africa Telephone: (27-11) 321 8700 Fax: (27-11) 444 2012
LIBYA	- See North/West Africa Regional Office - Daventry	Cummins Engine Company Ltd Royal Oak Way South Daventry, Northants NN11 5NU United Kingdom Telephone: (44-1327) 886000 Fax: (44-1327) 886106
LIECHTENSTEIN	- See Switzerland	AKSA Wurenlos AG Grosszelgstrasse 15 Wurenlos CH-5436 Switzerland Telephone: (41-56) 436 77 00 Fax: (41-56) 436 77 19
LUXEMBOURG		Cummins Diesel Deutschland GmbH Odenwaldstraße 23 Groß-Gerau, Hessen 64521 Germany Telephone: (49-6152) 174-0 Fax: (49-6152) 174-141

MACAU	- See Hong Kong	Cummins Hong Kong Ltd. 2/F Unison Industrial Centre 27-31 Au Pui Wan Street, Fo Tan, Shatin, N.T.cccc Hong Kong, Hong Kong Hong Kong S.A.R. Telephone: (852) 2606-5678 Fax: (852) 2691-1641
MADAGASCAR	- See Southern Africa Regional Office	Cummins Diesel South Africa (Pty) Ltd 13 Eastern Service Road Kelvin (Neighbourhood), Alexandra Gauteng, South Africa 2054 ZIP South Africa Telephone: (27-11) 321 8700 Fax: (27-11) 444 2012
MADEIRA ISLANDS	- See Portugal	Electro Central Vulcanizadora, Lda Rua Conselheiro Martins de Carvalho Lote 1480 Restelo Lisbon 1400 Portugal Telephone: (351-21) 3034800 Fax: (351-21) 3034801 / 2
MALAYSIA	Kuala Lumpur	Scott & English (M) Sdn Bhd 12 Jalan U1/15, Seksyen U1 Hicom-Glenmarie Industrial Park Shah Alam, Selangor Darul Ehsan 40150 Malaysia Telephone: (60-3) 7805-1111 Fax: (60-3) 7803-5122
MALI	- See Senegal (Matforce)	Matforce 10 Avenue Faidherbe Dakar Senegal Telephone: (221-8) 399500 Fax: (221-8) 399531 / 399550
MALTA	Valletta	International Machinery Ltd Regency House 254 Republic Street Valletta, Malta Malta Telephone: (356-21) 232620 / 233343 Fax: (356-21) 235484 / 247571
MARTINIQUE		Cummins Power South, LLC 9900 N.W. 77 Ave. Hialeah Gardens, FL 33016 Telephone: (305) 821-4200 Fax: (305) 557-2992
MEXICO	Guadalajara	Distribuidora Megamak de Occidente Metalurgia No. 2980 Fracc. Alamo Industrial Guadalajara, Jalisco 45560 Mexico Telephone: (52-3) 666-0329 / 666-0383 Fax: (52-3) 666-0333

MEXICO	Monterrey	<p>Converto Dixel Monterrey Privada Nazry Hasbun #2, Carr. Migue Aleman 14.8 Parque Industrial Hasna Apodaca, Nuevo León 66473 Mexico Telephone: (52-81) 81310200 Fax: (52-81) 81310200</p>
MEXICO	Merida	<p>Distribuidora Megamak del Sureste Av. Aviacion Civil No. 647 Col. Sambula Merida, Yucatan 97259 Mexico Telephone: (52-9) 930-1300 Fax: (52-9) 930-1315</p>
MEXICO	Puebla	<p>Cummins De Oriente, S.A. de C.V. Km. 10 + 400 Carr. Fed. Puegla-Tlaxcala Puebla, Puebla 72100 Mexico Telephone: (52-2) 248-7674 / 5 / 30-5083 / 6 Fax: (52-2) 249-7679</p>
MEXICO	Queretaro	<p>Converto Dixel Queretaro Blvd. Bernardo Quintana No. 518, Col. Arboledas Queretaro, Queretaro ZIP / Postal Code: 76140 Mexico Telephone: (52-442) 211-8700 Fax: (52-442) 211-8700</p>
MOROCCO	Casablanca	<p>Groupe Auto Hall 44 avenue Lalla Yacout Casablanca Morocco Telephone: (212-22) 442121 / 317044 / 317052 Fax: (212-22) 318915 / 315633</p>
MOZAMBIQUE	- See Southern Africa Regional Office - Kelvin	<p>Cummins Diesel South Africa (Pty) Ltd 13 Eastern Service Road Kelvin (Neighbourhood), Alexandra Gauteng, South Africa 2054 South Africa Telephone: (27-11) 321 8700 Fax: (27-11) 444 2012</p>
NEPAL	Pune (Office in India)	<p>Cummins Diesel Sales & Service (India) Ltd. 35A/1/2, Erandawana Pune, Maharashtra 411038 India Telephone: (91-20) 25431234 / 25430666 / 25431703 Fax: (91-20) 25439490</p>
NETHERLANDS	Dordrecht	<p>Cummins Holland B V Galvanistraat 35 Dordrecht, Zuid-Holland 3316 GH Netherlands Telephone: (31-78) 6181200 Fax: (31-78) 6176579</p>

NETHERLANDS ANTILLES		Cummins Power South, LLC 9900 N W 77th Ave. Hialeah Gardens, FL 33016 Telephone: (305) 821-4200 Fax: (305) 557-2992
NEW GUINEA	- See Papua New Guinea	Cummins Macdhui Street Lae Papua New Guinea Telephone: (675) 472 3699 Fax: (675) 472 3803
NEW GUINEA	- See Papua New Guinea	Cummins Macdhui Street Lae Papua New Guinea Telephone: (675) 472 3699 Fax: (675) 472 3803
New Zealand	Auckland	Cummins 9 Langley Road Manukau City Centre, South Auckland 1702 New Zealand Telephone: (64-9) 277 1000 Fax: (64-9) 277 1001
New Zealand	Christchurch	Cummins 33 Parkhouse Road Christchurch New Zealand Telephone: (64-3) 348 8170 Fax: (64-3) 348 8007
New Zealand	Dunedin	Cummins 8 Devon Street Dunedin New Zealand Telephone: (64-3) 477 8818 Fax: (64-3) 477 8061
New Zealand	Palmerston North	Cummins 852 - 860 Tremaine Avenue Palmerston North, Wanganui-Manawatu 5301 New Zealand Telephone: (64-3) 356 2209 Fax: (64-3) 356 9130
New Zealand	Rotorua	Cummins 328 Te Ngae Road Bay of Plenty Rotorua New Zealand Telephone: (64-7) 345 6699 Fax: (64-7) 345 6694
NICARAGUA	Managua	F. Alf. Pellas, S.A. Gadala Maria Cuatro Cuadras Oeste Barrio Acahualinca Managua, Nicaragua Nicaragua Telephone: (505) 268-2244 Fax: (505) 266-1060

NIGERIA	Lagos	Scoa Power (A Division of Scoa Nigeria Plc) 15, Creek Road Apapa Lagos Nigeria Telephone: (234-1) 5873623 / 5877322 Fax: (234-1) 5450646
NIGERIA	Paris (Office in France)	SCOA Inter Immeublearie Josephe Rue du Marechal de Lattre de Tassigny 78990 Elancourt, France France Telephone: (33-1) 30 688 268 Fax: (33-1) 30 688 269
NORTHERN IRELAND	- See United Kingdom	Cummins Engine Company Ltd Royal Oak Way South Daventry, Northants ZIP / Postal Code: NN11 5NU United Kingdom Telephone: (44-1327) 886000 Fax: (44-1327) 886106
NORWAY	Oslo	Cummins Norway A S Hestehagen 3 Postboks 151 Drobak 1441 Norway Telephone: (47) 64 90 70 80 Fax: (47) 64 90 70 90
OMAN	Ruwi	Universal Engineering Services LLC PO Box 2688 Ruwi 112 Oman Telephone: (968) 597531 / 597537 Fax: (968) 597514
PAKISTAN	Karachi	Cummins Sales & Service Pakistan 2 Bangalore Town Main Shahrah-e-Faisal Karachi 75350 Pakistan Telephone: + 92-21-4539603 / 4539604/ 4539605 Fax: + 92-21-4532519
PANAMA	Panama City	Grupo Tiesa, S.A. Via Transistmica Milla 8 Frente a Bacardi Partillo Panama Panama Telephone: (507) 231-0266 Fax: (507) 231-2535
PARAGUAY	Asuncion	De La Sobera S.A. Eusebio Ayala 1947 P.O. Box 1160 Asuncion Paraguay Telephone: (595) 21 202 913

PERU	Lima	Mitsui Maquinarias Peru, S.A. Av. Nicolas Ayllon 2648 Parcela Rustica Sta. Angelica Ate Lima ZIP / Postal Code: 03 Peru Telephone: (51-1) 326-4957 Fax: (51-1) 326-4954
PHILIPPINES	EDSA	Cummins Sales & Service Philippines, Inc. Lot 1 & 2, Block 15, LIIP Avenue, Laguna International Industrial Park, Mamplasan, Binan Laguna Philippines Telephone: (63-2) 843-0630 Fax: (63-2) 539-0290
POLAND		Cummins Engine Company Limited Sp. z.o.o. Oddzial w Polsce ul. Stawowa 119 Krakow 31-346 Poland Telephone: (48-12) 661 53 05 & (48-12) 661 53 25 Fax: (48-12) 661 53 15
PORTUGAL	Lisbon	Electro Central Vulcanizadora, Lda Rua Conselheiro Martins de Carvalho Lisbon ZIP / Postal Code: 1400 Portugal Telephone: (351-21) 3034800 Fax: (351-21) 3034801 / 2
QATAR	Doha	Jaidah Motors & Trading Co. P.O. Box 150 Doha, Qatar (Arabian Gulf) Telephone: (974) 4466888 Fax: (974) 441 4100 / 441 5400
REUNION	- See Lyon Regional Office - Lyon	CUMMINS DIESEL S.A. 39 rue Ampère BP 190 Chassieu cédex 69680 France Telephone: (33-4) 72 22 92 72 Fax: (33-4) 78 90 19 56
RIO DE ORO	- See Spain	Cummins Ventas y Servicio S. A. Torrelaguna 56 Madrid 28027 Spain Telephone: (34-91) 367 20 00 / 367 24 04 Fax: (34-91) 407 66 04
ROMANIA	- See Germany Regional Office - Gross-Gerau	Cummins Diesel Deutschland GmbH Odenwaldstraße 23 Groß-Gerau, Hessen 64521 Germany Telephone: (49-6152) 174-0 Fax: (49-6152) 174-141

RUSSIA		OOO Cummins Klyazma 1G Khimki District, Moscow Region 141400 Russia Telephone: (7-495) 540 86 24 / 25 Fax: (7-495) 540 86 99
RWANDA	Mechelen	Cummins Belgium N.V./S.A. Egide Walschaertsstraat, 2 Industriepark Zuid Mechelen 2800 Belgium Telephone: (32-15) 479 100 Fax: (32-15)275 686
ST. LUCIA		Cummins Power South, LLC 9900 N W 77th Ave. Hialeah Gardens, FL 33016 Telephone: (305) 821-4200 Fax: (305) 557-2992
ST. LUCIA	Miami (Office in U.S.A.)	Cummins Power South, LLC 9900 N W 77th Ave. Hialeah Gardens, FL 33016 Telephone: (305) 821-4200 Fax: (305) 557-2992
SAN MARINO	- See Italy	Cummins Italia S.p.A. ItalyVia Einaudi, 5 Peschiera Borromeo, Milano 20068 Telephone: (39-02) 51 65 581 Fax: (39-02) 51 65 58 56
SAO TOME AND PRINCIPE	- See North/West/East and Central Africa Regional Office - Daventry, England	Cummins Engine Company Ltd Royal Oak Way South Daventry, Northants ZIP / Postal Code: NN11 5NU United Kingdom Telephone: (44-1327) 886000 Fax: (44-1327) 886106
SAUDI ARABIA	Al-Khobar	General Contracting Company - OLAYAN P.O. Box 356 King Abdul Aziz Road Al-Khobar Saudi Arabia Telephone: (966-3) 882-0888 Fax: (966-3) 8828560 / 8827914
SCOTLAND	- See United Kingdom	Cummins UK Rutherford Drive Park Farm South Wellingborough, Northants ZIP / Postal Code: NN8 6AN United Kingdom Telephone: (44-1933) 334200 Fax: (44-1933) 334198

SENEGAL	Dakar	Matforce 10 Avenue Faidherbe Dakar Senegal Telephone: (221-8) 399500 Fax: (221-8) 399531/399550 Equipements et Services (Mining Only) BP 15372-Fann Dakar Senegal Contacts: Mr. Jean Smets Tel: (221-8) 60 77 76 & 24 73 62 Fax: (221-8) 60 95 98
SEYCHELLES	- See North/West/East & Central Africa Regional Office - Daventry, England	Cummins Engine Company Ltd Royal Oak Way South Daventry, Northants ZIP / Postal Code: NN11 5NU United Kingdom Telephone: (44-1327) 886000 Fax: (44-1327) 886106
SIERRA LEONE	- See North/West/East and Central Africa Regional Office - Daventry	Cummins Engine Company Ltd Royal Oak Way South Daventry, Northants ZIP / Postal Code: NN11 5NU United Kingdom Telephone: (44-1327) 886000 Fax: (44-1327) 886106
SINGAPORE	Singapore	Cummins Engine (Singapore) Pte Ltd 8 Tanjong Penjuru Singapore 609019 Singapore Telephone: (65) 6261-3555 Fax: (65) 6261-2405
SLOVAKIA		- See European Regional Office - Gross-Gerau
SOLOMON ISLANDS	The Czech branch covers sales and service for the Czech Republic and Slovakia	Cummins Czech Republic s.r.o. Komerční zóna Pruhonice Cestlice Obchodní 132 Praha, Prague 251 01 Czech Republic Telephone: (420-272) 680 110 Fax: (420-272) 680 090
SOLOMON ISLANDS	-See SOUTH PACIFIC ISLANDS	(Please contact) Cummins 2 Caribbean Drive Scoresby 3179 Victoria Telephone: (61-3) 9765-3222 Fax: (61-3) 9763-0079
SOMALIA	- see Southern Africa Regional Office	(Please contact) Cummins Diesel South Africa (Pty) Ltd 13 Eastern Service Road Kelvin (Neighbourhood), Alexandra Gauteng, South Africa 2054 South Africa Telephone: (27-11) 321 8700 Fax: (27-11) 444 2012

SOUTH AFRICA	Johannesburg	Cummins Diesel South Africa (Pty) Ltd 13 Eastern Service Road Kelvin (Neighbourhood), Alexandra Gauteng, South Africa 2054 South Africa Telephone: (27-11) 321 8700 Fax: (27-11) 444 2012
SOUTHWEST AFRICA	- see Southern Africa Regional Office	(Please contact) Cummins Diesel South Africa (Pty) Ltd 13 Eastern Service Road Kelvin (Neighbourhood), Alexandra Gauteng, South Africa 2054 South Africa Telephone: (27-11) 321 8700 Fax: (27-11) 444 2012
SPAIN	Madrid	Cummins Ventas y Servicio S. A. Torrelaguna, 56 Madrid 28027 Spain Telephone: (34-91) 367 20 00 / 367 24 04 Fax: (34-91) 407 66 04
SPANISH GUINEA	- See Spain	Cummins Ventas y Servicio S. A. Torrelaguna, 56 Madrid 28027 Spain Telephone: (34-91) 367 20 00 / 367 24 04 Fax: (34-91) 407 66 04
SRI LANKA	Colombo	Trade Promoters Ltd 272/25, Sudharshana Mawatha Malabe Sri Lanka Telephone: (94-11) 2413002 Fax: (94-11) 5550034
SUDAN	- See Middle East Regional Office - United Arab Emirates	United Arab Emirates Cummins Middle East FZE Units ZF 5/6 Jebel Ali Free Zone P.O.Box No 17636 Dubai United Arab Emirates Telephone: (971-4) 883 8998 Fax: (971-4) 883 7971
SURINAM		Cummins Power South, LLC 9900 N W 77th Ave. Hialeah Gardens, FL 33016 Telephone: (305) 821-4200 Fax: (305) 557-2992
SWAZILAND	- See South Africa	Cummins Diesel South Africa (Pty) Ltd 13 Eastern Service Road Kelvin (Neighbourhood), Alexandra Gauteng, South Africa ZIP / Postal Code: 2054 South Africa Telephone: (27-11) 321 8700 Fax: (27-11) 444 2012

SWEDEN	Stockholm	Cummins Sweden Maskingata 17C Brista Industriomade Märsta, Stockholm 195 60 Sweden Telephone: (46-8) 595 133 90 Fax: (46-8) 595 133 99
SWITZERLAND	Regensdorf	AKSA Wurenlos AG Grosszelgstrasse 15 Wuerenlos CH-5436 Switzerland Telephone: (41-1) 436 77 00 Fax: (41-56) 436 77 19
SYRIA	Damascus	Puzant Yacoubian & Sons Yacoubian Building Abou Baker El Saddik Street Damascus Syria Telephone: (963-11) 212 8600 Fax: (963-11) 212 8611
TAHITI, ISLAND OF	- See French Polynesia	Cummins MerCruiser Diesel 245 Brisbane Road Biggera Waters, Queensland 4216 Australia Telephone: (61-7) 5500 9060 Fax: (61-7) 5500 9070
TAIWAN		Cummins Taiwan Pte. Ltd. No.49 Ting Hu Road Tkuei Shan Hsiang Taoyuan, Taiwan 104 Taiwan Telephone: (886-3) 211-5160 Fax: (886-2) 211-4158
TANZANIA	- See South African Regional Office - Kelvin, South Africa	Cummins Diesel South Africa (Pty) Ltd 13 Eastern Service Road Kelvin (Neighbourhood), Alexandra Gauteng, South Africa ZIP / Postal Code: 2054 South Africa Telephone: (27-11) 321 8700 Fax: (27-11) 444 2012
THAILAND	Bangkok	DKSH (Thailand) Ltd 1696 New Petchburi Road Bangkok 10310 Thailand Telephone: (66-2) 254-4900 / 454-2173 Fax: (66-2) 253-5560 / 652-9417 / 8 / 9
TOGO (and BENIN)	Lome	TOGOMAT s.a. Zone Industrielle CNPPME Lome Togo Telephone: (228) 2272395 Fax: (228) 2270310

TONGA, ISLAND OF	-See SOUTH PACIFIC ISLANDS	(Please contact) Cummins 2 Caribbean Drive Scoresby 3179 Victoria AUSTRALIA Telephone: (61-3) 9765-3222 Fax: (61-3) 9763-0079
TRINIDAD and TOBAGO		Cummins Power South, LLC 9900 N W 77th Ave. Hialeah Gardens, FL 33016 Telephone: (305) 821-4200 Fax: (305) 557-2992
TURKEY	Istanbul	Hamamcioglu Muesseseleri Ticaret T.A.S. Okul Cad. No. 13 34956 Orhanli - P.K. 62 Tuzla Istanbul Turkey Telephone: (90-216) 394 3210 Fax: (90-216) 394 3208 / 9
UKRAINE	- See Moscow Regional Office - Moscow	Cummins Engine Company, Inc. Park Place Office E708, 113/1 Leninskiy Prospect Moscow 117198 Russia Telephone: (7-495) 956-51-22 / 23 Fax: (7-495) 956-53-62
UNITED ARAB EMIRATES	Dhabi	Cummins Middle East FZE Units ZF 05&06 Jebel Ali Free Zone Dhabi United Arab Emirates Telephone: (971-4) 883 8998 Fax: (971-4) 883 7971
UNITED KINGDOM	Wellingborough	Cummins UK Rutherford Drive Park Farm South Wellingborough, Northants NN8 6AN United Kingdom Telephone: (44-1933) 334200 Fax: (44-1933) 334198
VATICAN CITY	- See Italy	Cummins Italia S.p.A. Via Einaudi, 5 Peschiera Borromeo, Milano 20068 Italy Telephone: (39-02) 51 65 581 Fax: (39-02) 51 65 58 56
VENEZUELA	Caracas	Dieselval, C.A. Ave. Lisandro Alvarado, Sector La Florida Edificio Dieselval Valencia, Carabobo Venezuela ZIP / Postal Code: Venezuela Venezuela Telephone: (58-241) 8353074 / 8355265 Fax: (58-241) 8314553 / 8314818

VIETNAM	Hanoi	Diethelm & Co. Ltd., Engrg. 94, Tran Quoc Toan Street, Hoan Kiem District Hanoi Vietnam Telephone: (84-4) 9424-725 Fax: (84-4) 9424-730
VIETNAM	Ho Chi Minh City	Diethelm & Co. Ltd., Engrg. 189 Dien Bien Phu Street, Ward 15 Binh Thanh District Ho Chi Minh City, S.R. Vietnam Telephone: (84-8) 5121-334 Fax: (84-8) 5121-335
WESTERN SAMOA	-See SOUTH PACIFIC ISLANDS	(Please contact) Cummins 2 Caribbean Drive Scoresby 3179 Victoria AUSTRALIA Telephone: (61-3) 9765-3222 Fax: (61-3) 9763-0079
YEMEN	Sana'a	Zubieri Trading Company Al Qiyadah Street Sana'a Republic of Yemen Telephone: (967-1) 223943 / 224051 Fax: (967-1) 221611 / 245838
SERBIA & MONTENEGRO		Cummins Dizel Motori Prodaja i Servis Autoput, 22 11080 Zemum Beograd, Serbia & Montenegro Serbia & Montenegro Telephone: (381-11) 314 90 71 Fax: (381-11) 314 91 27
ZAMBIA	Ndola	Cummins Zambia Ltd Lufunza Avenue Ndola, Zambia Zambia Telephone: (260-2) 610 729 Fax: (260-2) 612 756
ZIMBABWE	Harare	Cummins Zimbabwe (Pvt) Ltd. 72 Birmingham Road Southerton, Zimbabwe Zimbabwe Telephones: (263-4) 621871 / 2 / 3 / 4 / 5 Fax: (263-4) 621880

Section TS - Troubleshooting Symptoms

Section Contents

	Page
Troubleshooting Procedures and Techniques	TS-1
General Information.....	TS-1
Troubleshooting Symptoms Charts	TS-2
General Information.....	TS-2
Air Compressor Air Pressure Rises Slowly	TS-3
Coolant Contamination.....	TS-11
Coolant Loss - External.....	TS-12
Coolant Temperature Above Normal - Gradual Overheat.....	TS-13
Coolant Temperature Above Normal - Sudden Overheat.....	TS-15
Engine Acceleration or Response Poor.....	TS-18
Engine Difficult to Start or Will Not Start (Exhaust Smoke).....	TS-20
Engine Difficult to Start or Will Not Start (No Exhaust Smoke).....	TS-22
Engine Noise Excessive — Combustion Knocks.....	TS-26
Engine Power Output Low.....	TS-27
Engine Runs Rough at Idle.....	TS-29
Engine Runs Rough or Misfires.....	TS-30
Engine Shuts Off Unexpectedly or Dies During Deceleration.....	TS-32
Engine Speed Surges at Low or High Idle.....	TS-33
Engine Speed Surges in PTO or Cruise Control.....	TS-36
Engine Speed Surges Under Load or in Operating Range.....	TS-34
Engine Starts But Will Not Keep Running.....	TS-37
Engine Will Not Crank or Cranks Slowly (Air Starter).....	TS-39
Engine Will Not Crank or Cranks Slowly (Electric Starter).....	TS-41
Engine Will Not Reach Rated Speed (RPM).....	TS-42
Fuel Consumption Excessive.....	TS-46
Fuel in the Lubricating Oil.....	TS-49
Lubricating Oil Consumption Excessive.....	TS-53
Lubricating Oil Contaminated.....	TS-54
Lubricating Oil Loss.....	TS-55
Lubricating Oil Pressure High.....	TS-57
Lubricating Oil Pressure Low.....	TS-58
Lubricating Oil Sludge in the Crankcase Excessive.....	TS-60
Turbocharger Leaks Engine Oil or Fuel.....	TS-64

This Page Left Intentionally Blank

Troubleshooting Procedures and Techniques

General Information

This guide describes some typical engine operating problems, their causes, and some acceptable corrections to those problems. Unless noted otherwise, the problems listed are those which an operator can diagnose and repair.

▲WARNING▲

Performing troubleshooting procedures NOT outlined in this section can result in equipment damage or personal injury or death. Troubleshooting must be performed by trained, experienced technicians. Consult a Cummins Authorized Repair Location for diagnosis and repair beyond that which is outlined, and for symptoms not listed in this section. Before beginning any troubleshooting, refer to General Safety Instructions in Section i of this manual.

Follow the suggestions below for troubleshooting:

- Study the complaint thoroughly before acting
- Refer to the engine system diagrams
- Do the easiest and most logical things first
- Find and correct the cause of the complaint

Troubleshooting Symptoms Charts

General Information

Use the charts on the following pages of this section to aid in diagnosing specific engine symptoms. Read each row of blocks from top to bottom. Follow through the chart to identify the corrective action.



Troubleshooting presents the risk of equipment damage, personal injury or death. Troubleshooting must be performed by trained, experienced technicians.

Air Compressor Air Pressure Rises Slowly

Cause

Correction

STEP 1

Air intake system restriction to air compressor is excessive

Replace the air compressor air cleaner (if installed). Check the air intake piping. Check engine air intake restriction if the air compressor inlet is plumbed to the vehicle or equipment intake system. Refer to Section 3 and Section 4.

OK

Go To Next Step

STEP 2

Air system leaks

Block the vehicle wheels and check the air system for leaks with spring brakes applied and released. Check for leaks from the air compressor gaskets and the air system hoses, fittings, tanks, and valves. Refer to the OEM service manuals.

OK

Go To Next Step

STEP 3

Carbon buildup is excessive in the air discharge line, downstream air valves, or cylinder head

Check for carbon buildup. Replace the air compressor discharge line and cylinder head assembly if necessary. Refer to Section 7.

OK

Go To Next Step

STEP 4

Contact a Cummins Authorized Repair Facility



Air Compressor Cycles Frequently

Cause	Correction
<p>STEP 1 Air system leaks</p>	<p>Block the vehicle wheels and check the air system for leaks with spring brakes applied and released. Check for leaks from the air compressor gaskets and the air system hoses, fittings, tanks, and valves. Refer to the OEM service manuals.</p>
<p>OK Go To Next Step</p>	
<p>STEP 2 Carbon buildup is excessive in the air discharge line, check valve, or cylinder head</p>	<p>Check for carbon buildup. Replace the air compressor discharge line, if necessary. Refer to Section 7.</p>
<p>OK Go To Next Step</p>	
<p>STEP 3 Air compressor pumping time is excessive</p>	<p>Replace the desiccant cartridge on the Turbo/CR 2000 air dryer. Refer to the OEM service manual. Check the air compressor duty cycle. Install a larger air compressor, if necessary. Refer to an Authorized Cummins Repair Facility.</p>
<p>OK Go To Next Step</p>	
<p>STEP 4 Contact a Cummins Authorized Repair Facility</p>	

Air Compressor Noise is Excessive

Cause

Correction

STEP 1

Carbon buildup is excessive in the air discharge line, downstream air valves, or cylinder head

Check for carbon buildup. Replace the air compressor discharge line and cylinder head assembly if necessary. Refer to Section 7.

OK

Go To Next Step

STEP 2

Air compressor is sending air pulses into the air tanks

Install a ping tank between the air dryer and the wet tank. Refer to the manufacturer's instructions.

OK

Go To Next Step

STEP 3

Ice buildup in the air system components

For all models, check for ice in low spots of the air discharge line, dryer inlet, and elbow fittings. On Holset® models, also check the Econ valve (if equipped). Refer to the OEM service manual.

OK

Go To Next Step

STEP 4

Contact a Cummins Authorized Repair Facility



Air Compressor Pumping Excess Lubricating Oil into the Air System

Cause	Correction
<p>STEP 1 Lubricating oil drain interval is excessive</p>	<p>Verify the correct lubricating oil drain interval. Refer to Section 2.</p>
<p>OK Go To Next Step</p>	
<p>STEP 2 Air intake system restriction to air compressor is excessive</p>	<p>Replace the air compressor air cleaner (if installed). Check the air intake piping. Check engine air intake restriction if the air compressor inlet is plumbed to the vehicle or equipment intake system. Refer to Section 3.</p>
<p>OK Go To Next Step</p>	
<p>STEP 3 Air compressor pumping time is excessive</p>	<p>Replace the desiccant cartridge on the Turbo/CR 2000 air dryer. Refer to the OEM service manual. Check the air compressor duty cycle. Install a larger air compressor, if necessary. Refer to an Authorized Cummins Repair Facility.</p>
<p>OK Go To Next Step</p>	
<p>STEP 4 Carbon buildup is excessive in the air discharge line, check valve, or cylinder head</p>	<p>Check for carbon buildup. Replace the air compressor discharge line, if necessary. Refer to Section 7.</p>
<p>OK Go To Next Step</p>	
<p>STEP 5 Contact a Cummins Authorized Repair Facility</p>	

Air Compressor Will Not Maintain Adequate Air Pressure (Not Pumping Continuously)

Cause

Correction

STEP 1
Air system leaks

Block the vehicle wheels and check the air system for leaks with spring brakes applied and released. Check for leaks from the air compressor gaskets and the air system hoses, fittings, tanks, and valves. Refer to the OEM service manual.

OK
Go To Next Step

STEP 2
Contact a Cummins Authorized Repair Facility



Air Compressor Will Not Stop Pumping

Cause

Correction

STEP 1
Air system leaks

Block the vehicle wheels and check the air system for leaks with spring brakes applied and released. Check for leaks from the air compressor gaskets and the air system hoses, fittings, tanks, and valves. Refer to the OEM service manual.

OK
Go To Next Step

STEP 2
Contact a Cummins Authorized Repair Facility

Alternator Not Charging or Insufficient Charging
Cause Correction

STEP 1 Alternator pulley is loose on the shaft	Tighten the pulley. Refer to OEM service manual.
OK Go To Next Step	
STEP 2 Batteries have malfunctioned	Check the condition of the batteries. Replace the batteries, if necessary. Refer to OEM service manual.
OK Go To Next Step	
STEP 3 Battery cables or connections are loose, broken, or corroded (excessive resistance)	Check the battery cables and connections.
OK Go To Next Step	
STEP 4 Alternator is overloaded, or alternator capacity is below specification	Install an alternator with a higher capacity. Refer to the OEM service manual.
OK Go To Next Step	
STEP 5 Alternator or voltage regulator is malfunctioning	Test the alternator output. Replace the alternator or voltage regulator if necessary. Refer to the OEM service manual.
OK Go To Next Step	
STEP 6 Battery temperature is above specification	Position the batteries away from heat sources. Refer to the OEM service manual.
OK Go To Next Step	
STEP 7 Electrical system is "open" (blown fuses, broken wires, or loose connections)	Check the fuses, wires, and connections. Refer to the OEM service manual and the manufacturer's wiring diagram.
OK Go To Next Step	
STEP 8 Vehicle gauge is malfunctioning	Check the vehicle gauge. Refer to the OEM service manual.
OK Go To Next Step	
STEP 9 Contact a Cummins Authorized Repair Facility	

Alternator Overcharging

Cause	Correction
<p>STEP 1 Batteries have failed</p>	<p>Check the condition of the batteries. Replace the batteries, if necessary. Refer to the OEM service manual.</p>
<p>OK Go To Next Step</p>	
<p>STEP 2 Voltage regulator is malfunctioning</p>	<p>Check the voltage regulator. Replace the voltage regulator, if necessary. Refer to an Authorized Cummins Repair Facility.</p>
<p>OK Go To Next Step</p>	
<p>STEP 3 Contact a Cummins Authorized Repair Facility</p>	

Coolant Contamination

Cause	Correction
<p>STEP 1 Coolant is rusty and has debris</p>	<p>Drain and flush the cooling system. Fill with correct mixture of antifreeze and water. Refer to Section 7.</p>
<p>OK Go To Next Step</p>	
<p>STEP 2 Transmission oil cooler or torque converter cooler is leaking</p>	<p>Check the transmission oil cooler and torque converter cooler for coolant leaks. Refer to the OEM service manual.</p>
<p>OK Go To Next Step</p>	
<p>STEP 3 Lubricating oil cooler is leaking</p>	<p>Check the lubricating oil cooler for coolant leaks and cracks. Refer to a Cummins Authorized Repair Facility.</p>
<p>OK Go To Next Step</p>	
<p>STEP 4 Cylinder head gasket is leaking</p>	<p>Check the cylinder head gasket. Refer to a Cummins Authorized Repair Facility.</p>
<p>OK Go To Next Step</p>	
<p>STEP 5 Contact a Cummins Authorized Repair Facility</p>	



Coolant Loss - External

Cause	Correction
<p>STEP 1 Coolant level is below specification</p>	<p>Inspect the engine and cooling system for external coolant leaks. Repair if necessary. Add coolant. Refer to the OEM service manual.</p>
<p>OK Go To Next Step</p>	
<p>STEP 2 External coolant leak</p>	<p>Inspect the engine for coolant leaking from hoses, draincocks, water manifold, jumper tubes, expansion and pipe plugs, fittings, radiator core, air compressor and cylinder head gaskets, lubricating oil cooler, water pump seal, cylinder block, and OEM-mounted components that have coolant flow. Refer to Section A.</p>
<p>OK Go To Next Step</p>	
<p>STEP 3 Radiator cap is not correct, is malfunctioning, or has low-pressure rating</p>	<p>Check the radiator pressure cap. Refer to the OEM service manual.</p>
<p>OK Go To Next Step</p>	
<p>STEP 4 Cooling system hose is collapsed, restricted, or leaking</p>	<p>Inspect the hoses. Refer to Section 4.</p>
<p>OK Go To Next Step</p>	
<p>STEP 5 Coolant fill line is restricted or obstructed</p>	<p>Check the coolant fill line for restrictions or obstructions. Refer to Section 7.</p>
<p>OK Go To Next Step</p>	
<p>STEP 6 Coolant is rusty and has debris</p>	<p>Drain and flush the cooling system. Fill with correct mixture of antifreeze and water. Refer to Section 7.</p>
<p>OK Go To Next Step</p>	
<p>STEP 7 Engine is overheating</p>	<p>Refer to the Coolant Temperature is Above Normal - Sudden Overheat or the Coolant Temperature is Above Normal - Gradual Overheat symptom tree.</p>
<p>OK Go To Next Step</p>	
<p>STEP 8 Contact a Cummins Authorized Repair Facility</p>	

Coolant Temperature Above Normal - Gradual Overheat

Cause

Correction

STEP 1

Charge air cooler fins, radiator fins, or air conditioner condenser fins are damaged or obstructed with debris

Inspect the charge air cooler, air conditioner condenser, and radiator fins. Clean, if necessary. Refer to Section 4 and the OEM service manual.

OK

Go To Next Step

STEP 2

Cold weather radiator cover or winterfront is closed

Open the cold weather radiator cover or the winterfront. Maintain a minimum of 387 cm² [60 in²] of opening at all times. Refer to Section 1.

OK

Go To Next Step

STEP 3

Coolant level is below specification

Inspect the engine and cooling system for external coolant leaks. Repair if necessary. Add coolant. Refer to Section 7.

OK

Go To Next Step

STEP 4

Electronic fault codes are active

For instructions on how to read active fault codes, refer to Section 1. If fault codes are active, contact a Cummins Authorized Repair Facility.

OK

Go To Next Step

STEP 5

Fan shroud is damaged or missing or the air recirculation baffles are damaged or missing

Inspect the shroud and the recirculation baffles. Repair, replace, or install, if necessary. Refer to the OEM service manual.

OK

Go To Next Step

STEP 6

Lubricating oil is contaminated with coolant or fuel

Refer to the Lubricating Oil Contaminated symptom tree.

OK

Go To Next Step

STEP 7

Cooling system hose is collapsed, restricted, or leaking

Inspect the hoses. Refer to Section 4.

OK

Go To Next Step

STEP 8

Coolant mixture of antifreeze and water is **not** correct

Verify the concentration of antifreeze in the coolant. Add antifreeze or water to correct the concentration. Refer to Section 5 and Section V.

OK

Go To Next Step

STEP 9

Lubricating oil level is above or below specification

Check the oil level. Add or drain oil, if necessary. Refer to Section 3. Use the oil recommended in Section V.

OK

Go To Next Step

Coolant Temperature Above Normal - Gradual Overheat

Cause

Correction

STEP 10
Coolant temperature gauge is malfunctioning

Test the temperature gauge. Repair or replace the gauge, if necessary.

OK

Go To Next Step

STEP 11
Fan drive belt is loose, tight, or **not** in alignment

Check the fan drive belt. Refer to Section 4.

OK

Go To Next Step

STEP 12
Vehicle cooling system is **not** adequate

Verify that the engine and vehicle cooling systems are using the correct components. Refer to the OEM specifications.

OK

Go To Next Step

STEP 13
Contact a Cummins Authorized Repair Facility

Coolant Temperature Above Normal - Sudden Overheat
Cause Correction

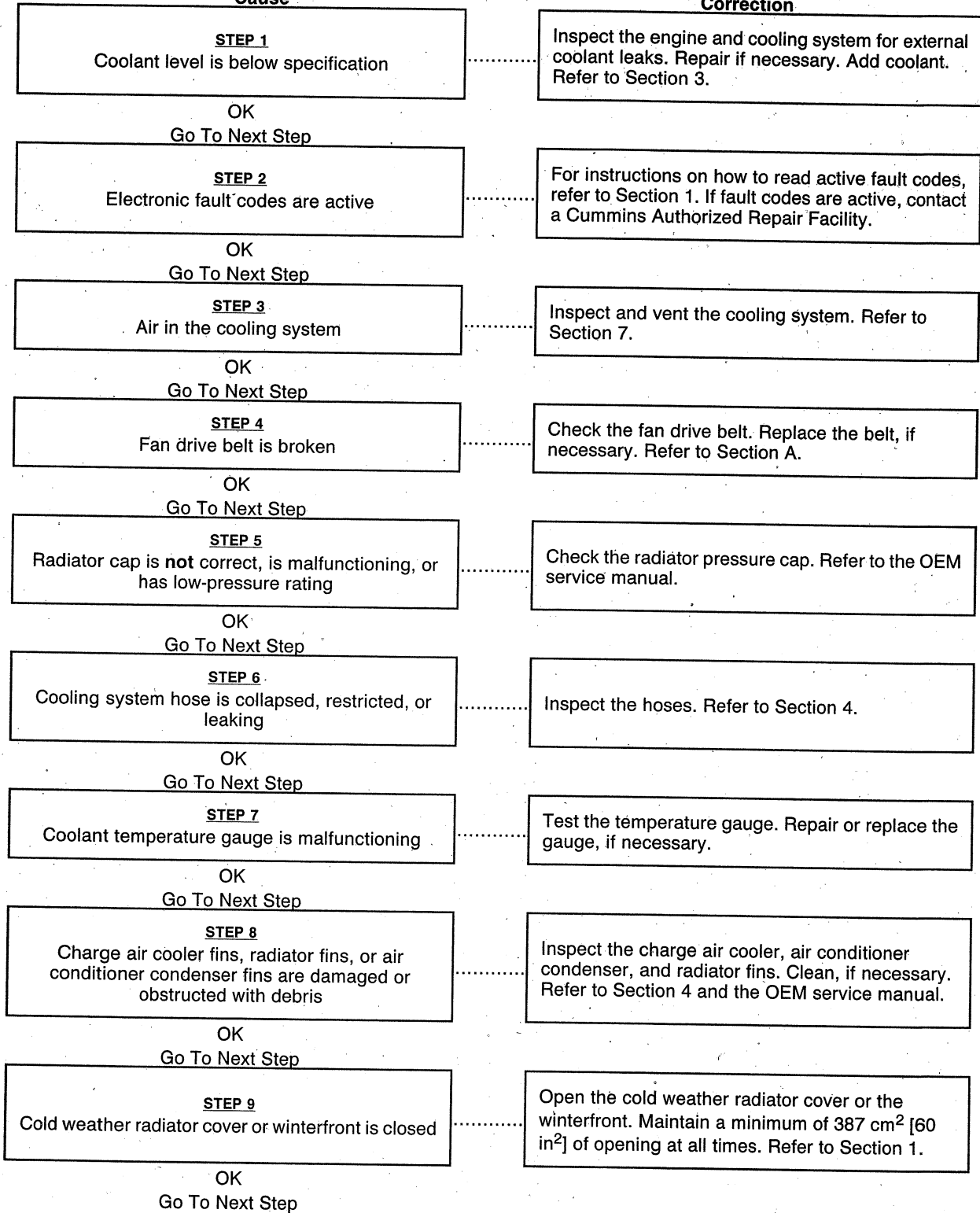

Coolant Temperature Above Normal - Sudden Overheat
Cause Correction

<p>STEP 10 Contact a Cummins Authorized Repair Facility</p>
--

Coolant Temperature Below Normal

Cause	Correction
<p>STEP 1 Coolant temperature gauge or sensor is malfunctioning</p>	<p>Test the gauge and the sensor. Repair or replace, if necessary. Refer to OEM service manual.</p>
<p>OK Go To Next Step</p>	
<p>STEP 2 Electronic fault codes are active</p>	<p>For instructions on how to read active fault codes, refer to Section 1. If fault codes are active, contact a Cummins Authorized Repair Facility.</p>
<p>OK Go To Next Step</p>	
<p>STEP 3 Engine is operating at low ambient temperature</p>	<p>Check the winterfront, shutters, and under-the-hood air. Use under-the-hood intake air in cold weather. Refer to Cold Weather Operation, Bulletin 3387266, and Section 1.</p>
<p>OK Go To Next Step</p>	
<p>STEP 4 Fan drive or fan controls are malfunctioning</p>	<p>Check the fan drive and controls. Refer to the OEM service manual.</p>
<p>OK Go To Next Step</p>	
<p>STEP 5 Coolant temperature gauge is malfunctioning</p>	<p>Test the temperature gauge. Repair or replace the gauge, if necessary.</p>
<p>OK Go To Next Step</p>	
<p>STEP 6 Thermostat is not correct or is malfunctioning</p>	<p>Check the thermostat for the correct part number and for correct operation. Contact a Cummins Authorized Repair Facility.</p>
<p>OK Go To Next Step</p>	
<p>STEP 7 Contact a Cummins Authorized Repair Facility</p>	

Engine Acceleration or Response Poor

Cause	Correction
<p>STEP 1 Operator technique is not correct</p> <p>OK Go To Next Step</p>	<p>Refer to Section 1, Operating Instructions.</p>
<p>STEP 2 Fuel level is low in the tank</p> <p>OK Go To Next Step</p>	<p>Fill the supply tank. Refer to the OEM service manual.</p>
<p>STEP 3 Vehicle parasitics are excessive</p> <p>OK Go To Next Step</p>	<p>Check the vehicle brakes for dragging, transmission malfunction, cooling fan operation cycle time, and engine-driven units. Refer to the OEM service manual.</p>
<p>STEP 4 Clutch is malfunctioning or is not correct</p> <p>OK Go To Next Step</p>	<p>Compare the drivetrain specifications to Cummins recommendations. Check the clutch for correct operation. Refer to the OEM service manual.</p>
<p>STEP 5 Drivetrain is not correctly matched to the engine</p> <p>OK Go To Next Step</p>	<p>Check for correct gearing and drivetrain components. Refer to the OEM vehicle specifications.</p>
<p>STEP 6 Electronic fault codes are active</p> <p>OK Go To Next Step</p>	<p>For instructions on how to read active fault codes, refer to Section 1. If fault codes are active, contact a Cummins Authorized Repair Facility.</p>
<p>STEP 7 Fuel leak</p> <p>OK Go To Next Step</p>	<p>Check the fuel lines, fuel connections, and fuel filters for leaks. Check the fuel lines to the supply tanks. Refer to the OEM service manual.</p>
<p>STEP 8 Intake manifold air temperature is above specification</p> <p>OK Go To Next Step</p>	<p>Refer to the Intake Manifold Air Temperature Above Specification symptom tree.</p>
<p>STEP 9 Charge air cooler is restricted or leaking</p> <p>OK Go To Next Step</p>	<p>Inspect the charge air cooler for air restrictions or leaks. Refer to Section 4.</p>

Engine Acceleration or Response Poor

Cause

Correction

STEP 10

Air in the fuel system

Check for air in the fuel system. Tighten or replace the fuel connections, fuel lines, fuel tank standpipe, and fuel filters as necessary.

OK

Go To Next Step

STEP 11

Air intake or exhaust leaks

Check for loose or damaged piping connections and missing pipe plugs. Check the turbocharger and exhaust manifold mounting. Refer to Section 4.

OK

Go To Next Step

STEP 12

Air intake system restriction is above specification

Check the air intake system for restriction. Clean or replace the air filter and inlet piping as necessary. Refer to Section 4.

OK

Go To Next Step

STEP 13

Fuel grade is **not** correct for the application or the fuel quality is poor

Operate the engine from a tank of high-quality fuel. Refer to Fuel Recommendations and Specifications in Section V.

OK

Go To Next Step

STEP 14

Fuel filter or fuel suction line is restricted

Replace the fuel filter. Refer to Section 5. Check the fuel suction line for restriction Section 5.

OK

Go To Next Step

STEP 15

Fuel supply is **not** adequate

Check the flow through the filter to locate the source of the restriction. Refer to Section 5.

OK

Go To Next Step

STEP 16

Contact a Cummins Authorized Repair Facility

Engine Difficult to Start or Will Not Start (Exhaust Smoke)

Cause	Correction
<p>STEP 1 Starting procedure is not correct</p>	<p>Verify the correct starting procedure. Refer to Section 1.</p>
<p>OK Go To Next Step</p>	
<p>STEP 2 Fuel level is low in the tank</p>	<p>Fill the supply tank. Refer to the OEM service manual.</p>
<p>OK Go To Next Step</p>	
<p>STEP 3 Electronic fault codes are active</p>	<p>For instructions on how to read active fault codes, refer to Section 1. If fault codes are active, contact a Cummins Authorized Repair Facility.</p>
<p>OK Go To Next Step</p>	
<p>STEP 4 Starting aid, if necessary for cold weather, is malfunctioning</p>	<p>Check for correct operation of the cold weather starting aid. Refer to Cold Weather Starting Aids in Section 1. Refer to the manufacturer's instructions.</p>
<p>OK Go To Next Step</p>	
<p>STEP 5 Engine block heater is malfunctioning (if equipped)</p>	<p>Check the electrical sources and wiring to the cylinder block heater. Replace the block heater, if necessary. Refer to the OEM service manual.</p>
<p>OK Go To Next Step</p>	
<p>STEP 6 Fuel heater is malfunctioning (if equipped)</p>	<p>Check the fuel heater and replace, if necessary. Refer to the manufacturer's instructions.</p>
<p>OK Go To Next Step</p>	
<p>STEP 7 Battery voltage is low</p>	<p>Check the batteries and the unswitched battery supply circuit. Refer to the OEM service manual.</p>
<p>OK Go To Next Step</p>	
<p>STEP 8 Keyswitch circuit is malfunctioning</p>	<p>Check the vehicle keyswitch circuit. Refer to the OEM service manual.</p>
<p>OK Go To Next Step</p>	
<p>STEP 9 Engine cranking speed is too slow</p>	<p>If the cranking speed is slower than 150 rpm, refer to the Engine Will Not Crank or Cranks Slowly symptom tree.</p>
<p>OK Go To Next Step</p>	

Engine Difficult to Start or Will Not Start (Exhaust Smoke)

Cause

Correction

<p>STEP 10 Vehicle parasitics are excessive</p>	<p>Check the vehicle brakes for dragging, transmission malfunction, cooling fan operation cycle time, and engine-driven units. Refer to the OEM service manual.</p>
<p>OK Go To Next Step</p>	
<p>STEP 11 Fuel leak</p>	<p>Check the fuel lines, fuel connections, and fuel filters for leaks. Check the fuel lines to the supply tanks. Refer to the OEM service manual.</p>
<p>OK Go To Next Step</p>	
<p>STEP 12 Air in the fuel system</p>	<p>Check for air in the fuel system. Tighten or replace the fuel connections, fuel lines, fuel tank standpipe, and fuel filters as necessary.</p>
<p>OK Go To Next Step</p>	
<p>STEP 13 Air intake system restriction is above specification</p>	<p>Check the air intake system for restriction. Clean or replace the air filter and inlet piping as necessary. Refer to Section 4.</p>
<p>OK Go To Next Step</p>	
<p>STEP 14 Fuel grade is not correct for the application or the fuel quality is poor</p>	<p>Operate the engine from a tank of high-quality fuel. Refer to Fuel Recommendations and Specifications in Section V.</p>
<p>OK Go To Next Step</p>	
<p>STEP 15 Fuel filter or fuel suction line is restricted</p>	<p>Replace the fuel filter. Refer to Section 5. Check the fuel suction line for restriction Section 5.</p>
<p>OK Go To Next Step</p>	
<p>STEP 16 Fuel supply is not adequate</p>	<p>Check the flow through the filter to locate the source of the restriction. Refer to Section 5.</p>
<p>OK Go To Next Step</p>	
<p>STEP 17 Contact a Cummins Authorized Repair Facility</p>	

Engine Difficult to Start or Will Not Start (No Exhaust Smoke)

Cause	Correction
<p>STEP 1 Starting procedure is not correct</p> <p>OK Go To Next Step</p>	<p>Verify the correct starting procedure. Refer to Section 1.</p>
<p>STEP 2 Fuel level is low in the tank</p> <p>OK Go To Next Step</p>	<p>Fill the supply tank. Refer to the OEM service manual.</p>
<p>STEP 3 Fuel grade is not correct for the application or the fuel quality is poor</p> <p>OK Go To Next Step</p>	<p>Operate the engine from a tank of high-quality fuel. Refer to Fuel Recommendations and Specifications in Section V.</p>
<p>STEP 4 Electronic fault codes are active</p> <p>OK Go To Next Step</p>	<p>For instructions on how to read active fault codes, refer to Section 1. If fault codes are active, contact a Cummins Authorized Repair Facility.</p>
<p>STEP 5 OEM engine protection system is malfunctioning</p> <p>OK Go To Next Step</p>	<p>Isolate the OEM engine protection system. Follow the OEM service manuals to check for a malfunction.</p>
<p>STEP 6 Battery voltage is low</p> <p>OK Go To Next Step</p>	<p>Check the batteries and the unswitched battery supply circuit. Refer to the OEM service manual.</p>
<p>STEP 7 Keyswitch circuit is malfunctioning</p> <p>OK Go To Next Step</p>	<p>Check the vehicle, equipment, or vessel keyswitch circuit. Refer to an Authorized Cummins Repair Facility.</p>
<p>STEP 8 Battery voltage supply to the electronic control module (ECM) is low, interrupted, or open</p> <p>OK Go To Next Step</p>	<p>Check the battery connections. Refer to the OEM service manual.</p>
<p>STEP 9 Moisture in the wiring harness connectors</p> <p>OK Go To Next Step</p>	<p>Dry the connectors with Cummins electronic cleaner, Part Number 3824510.</p>

Engine Difficult to Start or Will Not Start (No Exhaust Smoke)

Cause

Correction

<p>STEP 10 Air in the fuel system</p>	<p>Check for air in the fuel system. Tighten or replace the fuel connections, fuel lines, fuel tank standpipe, and fuel filters as necessary.</p>
<p>OK Go To Next Step</p>	
<p>STEP 11 Electronic control module (ECM) is locked up</p>	<p>Disconnect the battery cables for 30 seconds. Connect the battery cables, and start the engine.</p>
<p>OK Go To Next Step</p>	
<p>STEP 12 Fuel filter or fuel suction line is restricted</p>	<p>Replace the fuel filter. Refer to Section 5. Check the fuel suction line for restriction Section 5.</p>
<p>OK Go To Next Step</p>	
<p>STEP 13 Fuel supply is not adequate</p>	<p>Check the flow through the filter to locate the source of the restriction. Refer to Section 5.</p>
<p>OK Go To Next Step</p>	
<p>STEP 14 Fuel drain backup</p>	<p>Verify the fuel return line is plumbed to the bottom of the fuel tank.</p>
<p>OK Go To Next Step</p>	
<p>STEP 15 Contact a Cummins Authorized Repair Facility</p>	



Engine Noise Excessive

Cause	Correction
STEP 1 Fan drive belt is loose, tight, or not in alignment	Check the fan drive belt. Refer to Section 3.
OK Go To Next Step	
STEP 2 Lubricating oil is thin or diluted	Refer to the Lubricating Oil Specifications in Section V.
OK Go To Next Step	
STEP 3 Vibration damper is damaged	Inspect the vibration damper. Refer to Section 7.
OK Go To Next Step	
STEP 4 Air intake or exhaust leaks	Check for loose or damaged piping connections and missing pipe plugs. Check the turbocharger and exhaust manifold mounting. Refer to Section 3.
OK Go To Next Step	
STEP 5 Air intake or exhaust piping is contacting the chassis or cab	Inspect the air piping, chassis, and cab for contact points. Refer to the OEM service manual.
OK Go To Next Step	
STEP 6 Air intake system restriction is above specification	Check the air intake system for restriction. Clean or replace the air filter and inlet piping as necessary. Refer to Section 4.
OK Go To Next Step	
STEP 7 Coolant temperature is above specification	Refer to the Coolant Temperature is Above Normal - Sudden Overheator the Coolant Temperature is Above Normal - Gradual Overheat symptom tree.
OK Go To Next Step	
STEP 8 Engine mounts are worn, damaged, or not correct	Check the engine mounts. Refer to the OEM service manual.
OK Go To Next Step	
STEP 9 Fan clutch, hydraulic pump, or refrigerant compressor noise is excessive	Isolate each component and check for noise. Refer to the OEM service manual.
OK Go To Next Step	

Engine Noise Excessive

Cause

Correction

STEP 10

Fan is loose, damaged, or has excessive hub bearing end play

.....

Check the fan. Refer to Section 3.

OK

Go To Next Step

STEP 11

Contact a Cummins Authorized Repair Facility



Engine Noise Excessive — Combustion Knocks

Cause

Correction

STEP 1
Engine is operating at low ambient temperature

Check the winterfront, shutters, and under-the-hood air. Use under-the-hood intake air in cold weather. Refer to Cold Weather Operation, see Bulletin 3387266, and Section 1.

OK
Go To Next Step

STEP 2
Ether starting aid is malfunctioning

Repair or replace the ether starting aids. Refer to the manufacturer's instructions.

OK
Go To Next Step

STEP 3
Fuel grade is **not** correct for the application or the fuel quality is poor

Operate the engine from a tank of high-quality fuel. Refer to Fuel Recommendations and Specifications in Section V.

OK
Go To Next Step

STEP 4
Air in the fuel system

Check for air in the fuel system. Tighten or replace the fuel connections, fuel lines, fuel tank standpipe, and fuel filters as necessary.

OK
Go To Next Step

STEP 5
Coolant temperature is below specification

Refer to the Coolant Temperature Below Normal symptom tree.

OK
Go To Next Step

STEP 6
Contact a Cummins Authorized Repair Facility

Engine Power Output Low

Cause	Correction
<p>STEP 1 Electronic fault codes are active</p>	<p>For instructions on how to read active fault codes, refer to Section 1. If fault codes are active, contact a Cummins Authorized Repair Facility.</p>
<p>OK Go To Next Step</p>	
<p>STEP 2 Fuel grade is not correct for the application or the fuel quality is poor</p>	<p>Operate the engine from a tank of high-quality fuel. Refer to Fuel Recommendations and Specifications in Section V.</p>
<p>OK Go To Next Step</p>	
<p>STEP 3 Engine is operating above recommended altitude</p>	<p>Engine power decreases above recommended altitude. Refer to the OEM's altitude operation guidelines..</p>
<p>OK Go To Next Step</p>	
<p>STEP 4 Tachometer is not calibrated or is malfunctioning</p>	<p>Compare the tachometer reading with a handheld tachometer or an electronic service tool reading. Calibrate or replace the tachometer as necessary. Refer to the OEM service manual.</p>
<p>OK Go To Next Step</p>	
<p>STEP 5 Intake and exhaust system restricted</p>	<p>Check the intake and exhaust systems for restrictions. Inspect the intake air filter and replace as necessary.</p>
<p>OK Go To Next Step</p>	
<p>STEP 6 Air intake system restriction is above specification</p>	<p>Check the air intake system for restriction. Clean or replace the air filter and inlet piping as necessary. Refer to Section 4.</p>
<p>OK Go To Next Step</p>	
<p>STEP 7 Air intake or exhaust leaks</p>	<p>Check for loose or damaged piping connections and missing pipe plugs. Check the turbocharger and exhaust manifold mounting. Refer to Section 4.</p>
<p>OK Go To Next Step</p>	
<p>STEP 8 Air leak between the turbocharger and the intake manifold</p>	<p>Check for leaks in the air crossover tube, charge air cooler connections, hoses, or through holes in the manifold cover and repair or replace if necessary. Refer to the OEM service manual.</p>
<p>OK Go To Next Step</p>	

Engine Power Output Low

Cause	Correction
<p>STEP 9 Charge air cooler is restricted or leaking</p>	<p>Inspect the charge air cooler for air restrictions or leaks. Refer to Section 4.</p>
<p>OK Go To Next Step</p>	
<p>STEP 10 Fuel leak</p>	<p>Check the fuel lines, fuel connections, and fuel filters for leaks. Check the fuel lines to the supply tanks. Refer to the OEM service manual.</p>
<p>OK Go To Next Step</p>	
<p>STEP 11 Air in the fuel system</p>	<p>Check for air in the fuel system. Tighten or replace the fuel connections, fuel lines, fuel tank standpipe, and fuel filters as necessary.</p>
<p>OK Go To Next Step</p>	
<p>STEP 12 Fuel supply is not adequate</p>	<p>Check the flow through the filter to locate the source of the restriction. Refer to the OEM service manual.</p>
<p>OK Go To Next Step</p>	
<p>STEP 13 Fuel return restriction excessive</p>	<p>Inspect the fuel return lines for restrictions. Refer to the OEM service manual.</p>
<p>OK Go To Next Step</p>	
<p>STEP 14 Fuel filter or fuel suction line is restricted</p>	<p>Replace the fuel filter. Refer to Section 5. Check the fuel suction line for restriction Section 5.</p>
<p>OK Go To Next Step</p>	
<p>STEP 15 Vehicle parasitics are excessive</p>	<p>Check the vehicle brakes for dragging, transmission malfunction, cooling fan operation cycle time, and engine-driven units. Refer to the OEM service manual.</p>
<p>OK Go To Next Step</p>	
<p>STEP 16 Lubricating oil level above specification</p>	<p>Check the oil level. Verify the oil pan capacity. Fill the system to the specified level. Refer to Section V.</p>
<p>OK Go To Next Step</p>	
<p>STEP 17 Contact a Cummins Authorized Repair Facility</p>	

Engine Runs Rough at Idle

Cause	Correction
<p>STEP 1 Engine is cold</p> <p>OK Go To Next Step</p>	<p>Allow the engine to warm to operating temperature. If the engine will not reach operating temperature, refer to the Coolant Temperature Below Normal symptom tree.</p>
<p>STEP 2 Electronic fault codes are active</p> <p>OK Go To Next Step</p>	<p>For instructions on how to read active fault codes, refer to Section 1. If fault codes are active, contact a Cummins Authorized Repair Facility.</p>
<p>STEP 3 Idle speed is set too low for accessories</p> <p>OK Go To Next Step</p>	<p>Check and adjust the low-idle screw. Refer to a Cummins Authorized Repair Facility.</p>
<p>STEP 4 Air in the fuel system</p> <p>OK Go To Next Step</p>	<p>Check for air in the fuel system. Tighten or replace the fuel connections, fuel lines, fuel tank standpipe, and fuel filters as necessary.</p>
<p>STEP 5 Fuel filter or fuel suction line is restricted</p> <p>OK Go To Next Step</p>	<p>Replace the fuel filter. Refer to Section 5. Check the fuel suction line for restriction Section 5.</p>
<p>STEP 6 Fuel supply is not adequate</p> <p>OK Go To Next Step</p>	<p>Check the flow through the filter to locate the source of the restriction. Refer to Section 5.</p>
<p>STEP 7 Engine mounts are worn, damaged, or not correct</p> <p>OK Go To Next Step</p>	<p>Check the engine mounts. Refer to the OEM service manual.</p>
<p>STEP 8 Moisture in the wiring harness connectors</p> <p>OK Go To Next Step</p>	<p>Dry the connectors with Cummins electronic cleaner, Part Number 3824510.</p>
<p>STEP 9 Fuel grade is not correct for the application or the fuel quality is poor</p> <p>OK Go To Next Step</p>	<p>Operate the engine from a tank of high-quality fuel. Refer to Fuel Recommendations and Specifications in Section V.</p>
<p>STEP 10 Contact a Cummins Authorized Repair Facility</p>	

Engine Runs Rough or Misfires

Cause	Correction
<p>STEP 1 Engine is cold</p>	<p>Allow the engine to warm to operating temperature. If the engine will not reach operating temperature, refer to the Coolant Temperature Below Normal symptom tree.</p>
<p>OK Go To Next Step</p>	
<p>STEP 2 Electronic fault codes are active</p>	<p>For instructions on how to read active fault codes, refer to Section 1. If fault codes are active, contact a Cummins Authorized Repair Facility.</p>
<p>OK Go To Next Step</p>	
<p>STEP 3 Air in the fuel system</p>	<p>Check for air in the fuel system. Tighten or replace the fuel connections, fuel lines, fuel tank standpipe and fuel filters as necessary. Vent air from the system. Refer to Section 5.</p>
<p>OK Go To Next Step</p>	
<p>STEP 4 Fuel grade is not correct for the application or the fuel quality is poor</p>	<p>Operate the engine from a tank of high-quality fuel. Refer to Fuel Recommendations and Specifications in Section V.</p>
<p>OK Go To Next Step</p>	
<p>STEP 5 Fuel leak</p>	<p>Check the fuel lines, fuel connections, and fuel filters for leaks. Refer to the OEM service manual.</p>
<p>OK Go To Next Step</p>	
<p>STEP 6 Fuel filter is plugged</p>	<p>Measure the fuel pressure before and after the fuel filter. Refer to Section 5.</p>
<p>OK Go To Next Step</p>	
<p>STEP 7 Fuel supply is not adequate</p>	<p>Check the flow through the filter to locate the source of the restriction. Refer to Section 5.</p>
<p>OK Go To Next Step</p>	
<p>STEP 8 Fuel lift pump is malfunctioning</p>	<p>Check the fuel lift pump for correct operation. Check the pump output pressure. Replace the fuel lift pump if necessary. Refer to an Authorized Cummins Repair Facility.</p>
<p>OK Go To Next Step</p>	
<p>STEP 9 Engine mounts are worn, damaged, or not correct</p>	<p>Check the engine mounts. Refer to the OEM service manual.</p>
<p>OK Go To Next Step</p>	

Engine Runs Rough or Misfires

Cause

Correction

STEP 10
Moisture in the wiring harness connectors

Dry the connectors with Cummins electronic cleaner, Part Number 3824510.

OK

Go To Next Step

STEP 11
Contact a Cummins Authorized Repair Facility



Engine Shuts Off Unexpectedly or Dies During Deceleration

Cause	Correction
<p>STEP 1 Engine will not restart</p> <p>OK Go To Next Step</p>	<p>Refer to the Engine Difficult to Start or Will Not Start symptom tree.</p>
<p>STEP 2 Fuel level is low in the tank</p> <p>OK Go To Next Step</p>	<p>Fill the supply tank. Refer to the OEM service manual.</p>
<p>STEP 3 Electronic fault codes are active</p> <p>OK Go To Next Step</p>	<p>For instructions on how to read active fault codes, refer to Section 1. If fault codes are active, contact a Cummins Authorized Repair Facility.</p>
<p>STEP 4 Idle shutdown or PTO shutdown features are activated</p> <p>OK Go To Next Step</p>	<p>Check the time limit on idle and PTO shutdowns with an electronic service tool. Refer to Electronic Controlled Fuel System in Section 1.</p>
<p>STEP 5 Moisture in the wiring harness connectors</p> <p>OK Go To Next Step</p>	<p>Dry the connectors with Cummins electronic cleaner, Part Number 3824510.</p>
<p>STEP 6 OEM engine protection system is malfunctioning</p> <p>OK Go To Next Step</p>	<p>Isolate the OEM engine protection system. Follow the OEM service manuals to check for a malfunction.</p>
<p>STEP 7 Battery voltage supply to the electronic control module (ECM) is low, interrupted, or open</p> <p>OK Go To Next Step</p>	<p>Check the battery connections, the fuses, and the unswitched battery supply circuit. Refer to the OEM service manual.</p>
<p>STEP 8 Air in the fuel system</p> <p>OK Go To Next Step</p>	<p>Check for air in the fuel system. Tighten or replace the fuel connections, fuel lines, fuel tank standpipe, and fuel filters as necessary. Refer to Section 5.</p>
<p>STEP 9 Contact a Cummins Authorized Repair Facility</p>	

Engine Speed Surges at Low or High Idle

Cause

Correction

<p>STEP 1 Fuel level is low in the tank</p>	<p>Fill the supply tank. Refer to the OEM service manual.</p>
<p>OK Go To Next Step</p>	
<p>STEP 2 Engine idle speed is set too low</p>	<p>Adjust the idle speed. Refer to an Authorized Cummins Repair Facility.</p>
<p>OK Go To Next Step</p>	
<p>STEP 3 Electronic fault codes are active</p>	<p>For instructions on how to read active fault codes, refer to Section 1. If fault codes are active, contact a Cummins Authorized Repair Facility.</p>
<p>OK Go To Next Step</p>	
<p>STEP 4 Moisture in the wiring harness connectors</p>	<p>Dry the connectors with Cummins electronic cleaner, Part Number 3824510.</p>
<p>OK Go To Next Step</p>	
<p>STEP 5 Air in the fuel system</p>	<p>Check for air in the fuel system. Tighten or replace the fuel connections, fuel lines, fuel tank standpipe and fuel filters as necessary. Vent air from the system. Refer to Section 5.</p>
<p>OK Go To Next Step</p>	
<p>STEP 6 Fuel filter is plugged</p>	<p>Measure the fuel pressure before and after the fuel filter. Refer to Section 5.</p>
<p>OK Go To Next Step</p>	
<p>STEP 7 Fuel supply is not adequate</p>	<p>Check the flow through the filter to locate the source of the restriction. Refer to Section 5.</p>
<p>OK Go To Next Step</p>	
<p>STEP 8 Fuel lift pump is malfunctioning</p>	<p>Check the fuel lift pump for correct operation. Check the pump output pressure. Replace the fuel lift pump if necessary. Refer to an Authorized Cummins Repair Facility.</p>
<p>OK Go To Next Step</p>	
<p>STEP 9 Fuel grade is not correct for the application or the fuel quality is poor</p>	<p>Operate the engine from a tank of high-quality fuel. Refer to Fuel Recommendations and Specifications in Section V.</p>
<p>OK Go To Next Step</p>	
<p>STEP 10 Contact a Cummins Authorized Repair Facility</p>	

Engine Speed Surges Under Load or in Operating Range

Cause	Correction
<p>STEP 1 Fuel level is low in the tank</p>	<p>Fill the supply tank. Refer to the OEM service manual.</p>
<p>OK Go To Next Step</p>	
<p>STEP 2 Electronic fault codes are active</p>	<p>For instructions on how to read active fault codes, refer to Section 1. If fault codes are active, contact a Cummins Authorized Repair Facility.</p>
<p>OK Go To Next Step</p>	
<p>STEP 3 Moisture in the wiring harness connectors</p>	<p>Dry the connectors with Cummins electronic cleaner, Part Number 3824510.</p>
<p>OK Go To Next Step</p>	
<p>STEP 4 Air in the fuel system</p>	<p>Check for air in the fuel system. Tighten or replace the fuel connections, fuel lines, fuel tank standpipe and fuel filters as necessary. Vent air from the system. Refer to Section 5.</p>
<p>OK Go To Next Step</p>	
<p>STEP 5 Fuel filter is plugged</p>	<p>Measure the fuel pressure before and after the fuel filter. Refer to Section 5.</p>
<p>OK Go To Next Step</p>	
<p>STEP 6 Fuel supply is not adequate</p>	<p>Check the flow through the filter to locate the source of the restriction. Refer to Section 5.</p>
<p>OK Go To Next Step</p>	
<p>STEP 7 Idling with excessive load</p>	<p>Use the PTO feature for loaded conditions at low engine speeds. Refer to Section 1.</p>
<p>OK Go To Next Step</p>	
<p>STEP 8 Vehicle parasitics are excessive</p>	<p>Check the vehicle brakes for dragging, transmission malfunction, cooling fan operation cycle time, and engine-driven units. Refer to the OEM service manual.</p>
<p>OK Go To Next Step</p>	
<p>STEP 9 Clutch is malfunctioning or is not correct</p>	<p>Compare the drivetrain specifications to Cummins recommendations. Check the clutch for correct operation. Refer to the OEM service manual.</p>
<p>OK Go To Next Step</p>	

Engine Speed Surges Under Load or in Operating Range

Cause

Correction

STEP 10

Fuel grade is **not** correct for the application or the fuel quality is poor

Operate the engine from a tank of high-quality fuel. Refer to Fuel Recommendations and Specifications in Section V.

OK

Go To Next Step

STEP 11

Contact a Cummins Authorized Repair Facility



Engine Speed Surges in PTO or Cruise Control

Cause	Correction
<p>STEP 1 Engine speed also surges at idle</p> <p>OK Go To Next Step</p>	<p>Refer to the Engine Speed Surges at Low or High Idle symptom tree.</p>
<p>STEP 2 Engine speed surges while in the normal operating range and not in PTO or cruise control</p> <p>OK Go To Next Step</p>	<p>Refer to the Engine Speed Surges Under Load or in Operating Range symptom tree.</p>
<p>STEP 3 Electronic fault codes are active</p> <p>OK Go To Next Step</p>	<p>For instructions on how to read active fault codes, refer to Section 1. If fault codes are active, contact a Cummins Authorized Repair Facility.</p>
<p>STEP 4 Moisture in the wiring harness connectors</p> <p>OK Go To Next Step</p>	<p>Dry the connectors with Cummins electronic cleaner, Part Number 3824510.</p>
<p>STEP 5 Fuel filter is plugged</p> <p>OK Go To Next Step</p>	<p>Measure the fuel pressure before and after the fuel filter. Refer to Section 5.</p>
<p>STEP 6 Fuel supply is not adequate</p> <p>OK Go To Next Step</p>	<p>Check the flow through the filter to locate the source of the restriction. Refer to Section 5.</p>
<p>STEP 7 Contact a Cummins Authorized Repair Facility</p>	

Engine Starts But Will Not Keep Running

Cause	Correction
<p style="text-align: center;">STEP 1</p> <p style="text-align: center;">Fuel level is low in the tank</p>	<p>Fill the supply tank. Refer to the OEM service manual.</p>
<p style="text-align: center;">OK</p> <p style="text-align: center;">Go To Next Step</p>	
<p style="text-align: center;">STEP 2</p> <p style="text-align: center;">Battery voltage supply to the electronic control module (ECM) is low, interrupted, or open</p>	<p>Check the battery connections. Refer to the OEM service manual.</p>
<p style="text-align: center;">OK</p> <p style="text-align: center;">Go To Next Step</p>	
<p style="text-align: center;">STEP 3</p> <p style="text-align: center;">Electronic fault codes are active</p>	<p>For instructions on how to read active fault codes, refer to Section 1. If fault codes are active, contact a Cummins Authorized Repair Facility.</p>
<p style="text-align: center;">OK</p> <p style="text-align: center;">Go To Next Step</p>	
<p style="text-align: center;">STEP 4</p> <p style="text-align: center;">Idle speed is set too low for accessories</p>	<p>Check and adjust the low-idle screw. Refer to a Cummins Authorized Repair Facility.</p>
<p style="text-align: center;">OK</p> <p style="text-align: center;">Go To Next Step</p>	
<p style="text-align: center;">STEP 5</p> <p style="text-align: center;">Engine-driven units are engaged</p>	<p>Disengage engine-driven units. Refer to the OEM service manual.</p>
<p style="text-align: center;">OK</p> <p style="text-align: center;">Go To Next Step</p>	
<p style="text-align: center;">STEP 6</p> <p style="text-align: center;">Air in the fuel system</p>	<p>Check for air in the fuel system. Tighten or replace the fuel connections, fuel lines, fuel tank standpipe, and fuel filters as necessary.</p>
<p style="text-align: center;">OK</p> <p style="text-align: center;">Go To Next Step</p>	
<p style="text-align: center;">STEP 7</p> <p style="text-align: center;">Fuel filter or fuel suction line is restricted</p>	<p>Replace the fuel filter. Refer to Section 5. Check the fuel suction line for restrictionSection 5.</p>
<p style="text-align: center;">OK</p> <p style="text-align: center;">Go To Next Step</p>	
<p style="text-align: center;">STEP 8</p> <p style="text-align: center;">Fuel grade is not correct for the application or the fuel quality is poor</p>	<p>Operate the engine from a tank of high-quality fuel. Refer to Fuel Recommendations and Specifications in Section V.</p>
<p style="text-align: center;">OK</p> <p style="text-align: center;">Go To Next Step</p>	
<p style="text-align: center;">STEP 9</p> <p style="text-align: center;">Contact a Cummins Authorized Repair Facility</p>	

Engine Vibration Excessive

Cause	Correction
<p style="text-align: center;">STEP 1 Belt-driven accessories are malfunctioning</p> <p style="text-align: center;">OK Go To Next Step</p>	<p>Check the fan hub, alternator, refrigerant compressor, and hydraulic pump for interference. Isolate belt-driven accessories and check for vibration. Refer to Section 3 and Section 4.</p>
<p style="text-align: center;">STEP 2 Air compressor pumping time is excessive</p> <p style="text-align: center;">OK Go To Next Step</p>	<p>Refer to the Air Compressor Cycles Frequently symptom tree.</p>
<p style="text-align: center;">STEP 3 Engine idle speed is set too low (electronically controlled fuel systems)</p> <p style="text-align: center;">OK Go To Next Step</p>	<p>Verify the correct idle speed setting. Increase the idle speed with the idle increment switch or an electronic service tool. Refer to Section 1.</p>
<p style="text-align: center;">STEP 4 Engine mounts are worn, damaged, or not correct</p> <p style="text-align: center;">OK Go To Next Step</p>	<p>Check the engine mounts. Refer to the OEM service manual.</p>
<p style="text-align: center;">STEP 5 Fan is loose, damaged, or has excessive hub bearing end play</p> <p style="text-align: center;">OK Go To Next Step</p>	<p>Check the fan. Refer to Section 3.</p>
<p style="text-align: center;">STEP 6 Engine is misfiring</p> <p style="text-align: center;">OK Go To Next Step</p>	<p>Refer to the Engine Runs Rough or Misfires symptom tree.</p>
<p style="text-align: center;">STEP 7 Electronic fault codes are active</p> <p style="text-align: center;">OK Go To Next Step</p>	<p>For instructions on how to read active fault codes, refer to Section 1. If fault codes are active, contact a Cummins Authorized Repair Facility.</p>
<p style="text-align: center;">STEP 8 Vibration damper is damaged</p> <p style="text-align: center;">OK Go To Next Step</p>	<p>Inspect the vibration damper. Refer to Section 7.</p>
<p style="text-align: center;">STEP 9 Alternator bearing worn or damaged</p> <p style="text-align: center;">OK Go To Next Step</p>	<p>Clean and replace the alternator. Refer to the OEM service manual.</p>
<p style="text-align: center;">STEP 10 Contact a Cummins Authorized Repair Facility</p>	

Engine Will Not Crank or Cranks Slowly (Air Starter)

Cause

Correction

<p>STEP 1 Air pressure is low in the air tanks</p>	<p>Increase air pressure with an external air source. Refer to the OEM service manual.</p>
<p>OK Go To Next Step</p>	
<p>STEP 2 Engine-driven units are engaged</p>	<p>Disengage engine-driven units. Refer to the OEM Service Manual.</p>
<p>OK Go To Next Step</p>	
<p>STEP 3 Lubricating oil level above specification</p>	<p>Check the oil level. Verify the oil pan capacity. Fill the system to the specified level. Refer to Section V.</p>
<p>OK Go To Next Step</p>	
<p>STEP 4 Lubricating oil does not meet specifications for operating conditions</p>	<p>Change the oil and filters. Refer to Section 5. Use the oil recommended in Section V.</p>
<p>OK Go To Next Step</p>	
<p>STEP 5 Electrical system is "open" (blown fuses, broken wires, or loose connections)</p>	<p>Check the fuses, wires, and connections. Refer to the OEM service manual and manufacturer's wiring diagram.</p>
<p>OK Go To Next Step</p>	
<p>STEP 6 Battery charge is low</p>	<p>Check battery. If the battery is low, check the alternator for proper charging. Charge the battery, and replace if necessary. Refer to the OEM service manual.</p>
<p>OK Go To Next Step</p>	
<p>STEP 7 Keyswitch circuit is malfunctioning</p>	<p>Check the vehicle, equipment, or vessel keyswitch circuit. Refer to the OEM service manual.</p>
<p>OK Go To Next Step</p>	
<p>STEP 8 Starter solenoid is not receiving voltage</p>	<p>Check the battery supply to the starter solenoid. Refer to the OEM service manual.</p>
<p>OK Go To Next Step</p>	
<p>STEP 9 Starting motor is malfunctioning or starting motor is not correct</p>	<p>Check the starting motor operation. Compare the starting motor with the engine and vehicle specifications. Refer to the manufacturer's instructions.</p>
<p>OK Go To Next Step</p>	

Engine Will Not Crank or Cranks Slowly (Air Starter)

Cause

Correction

STEP 10

Contact a Cummins Authorized Repair Facility

Engine Will Not Crank or Cranks Slowly (Electric Starter)

Cause

Correction

STEP 1

Batteries are cold

Check the battery heater. Refer to the manufacturer's instructions.

OK

Go To Next Step

STEP 2

Battery cables or connections are loose, broken, or corroded (excessive resistance)

Check the battery cables and connections.

OK

Go To Next Step

STEP 3

Electrical system is "open" (blown fuses, broken wires, or loose connections)

Check the fuses, wires, and connections. Refer to the OEM service manual and manufacturer's wiring diagram.

OK

Go To Next Step

STEP 4

Battery charge is low

Check battery. If the battery is low, check the alternator for proper charging. Charge the battery, and replace if necessary. Refer to the OEM service manual.

OK

Go To Next Step

STEP 5

Keyswitch circuit is malfunctioning

Check the vehicle, equipment, or vessel keyswitch circuit. Refer to the OEM service manual.

OK

Go To Next Step

STEP 6

Starter solenoid is **not** receiving voltage

Check the battery supply to the starter solenoid. Refer to the OEM service manual.

OK

Go To Next Step

STEP 7

Engine-driven units are engaged

Disengage engine-driven units. Refer to the OEM Service Manual.

OK

Go To Next Step

STEP 8

Lubricating oil level above specification

Check the oil level. Verify the oil pan capacity. Fill the system to the specified level. Refer to Section V.

OK

Go To Next Step

STEP 9

Lubricating oil does **not** meet specifications for operating conditions

Change the oil and filters. Refer to Section 5. Use the oil recommended in Section V.

OK

Go To Next Step

STEP 10

Contact a Cummins Authorized Repair Facility

Engine Will Not Reach Rated Speed (RPM)

Cause	Correction
<p>STEP 1 Electronic fault codes are active</p>	<p>For instructions on how to read active fault codes, refer to Section 1. If fault codes are active, contact a Cummins Authorized Repair Facility.</p>
<p>OK Go To Next Step</p>	
<p>STEP 2 Vehicle speed is too low for adequate cooling with high engine load</p>	<p>Reduce the engine load. Increase the engine (fan) rpm by downshifting.</p>
<p>OK Go To Next Step</p>	
<p>STEP 3 Tachometer is not calibrated or is malfunctioning</p>	<p>Compare the tachometer reading with a handheld tachometer or an electronic service tool reading. Calibrate or replace the tachometer as necessary. Refer to the OEM service manual.</p>
<p>OK Go To Next Step</p>	
<p>STEP 4 Air-fuel tube leaking, wastegate diaphragm ruptured, or wastegate plumbing damaged</p>	<p>Tighten the fittings, repair plumbing, replace wastegate diaphragm. Refer to the OEM service manual or an Authorized Cummins Repair Facility.</p>
<p>OK Go To Next Step</p>	
<p>STEP 5 Charge air cooler restricted (if equipped)</p>	<p>Inspect the air cooler for internal and external restrictions. Replace the restricted cooler if necessary. Refer to the OEM service manual.</p>
<p>OK Go To Next Step</p>	
<p>STEP 6 Fuel supply is not adequate</p>	<p>Check the flow through the filter to locate the source of the restriction. Refer to the OEM service manual.</p>
<p>OK Go To Next Step</p>	
<p>STEP 7 Exhaust back pressure too high</p>	<p>Measure and correct if above specification. Refer to an Authorized Cummins Repair Facility.</p>
<p>OK Go To Next Step</p>	
<p>STEP 8 Fuel lift pump is malfunctioning</p>	<p>Check the fuel lift pump for correct operation. Check the pump output pressure. Replace the fuel lift pump if necessary. Refer to an Authorized Cummins Repair Facility.</p>
<p>OK Go To Next Step</p>	

Engine Will Not Reach Rated Speed (RPM)

Cause

Correction

STEP 9
Vehicle parasitics are excessive

Check the vehicle brakes for dragging, transmission malfunction, cooling fan operation cycle time, and engine-driven units. Refer to the OEM service manual.

OK

Go To Next Step

STEP 10
Engine power output is low

Refer to the Engine Power Outlet Low symptom tree.

OK

Go To Next Step

STEP 11
Contact a Cummins Authorized Repair Facility



Fault Code Warning Lamps Stay On (No Apparent Reason)

Cause	Correction
<p>STEP 1 Diagnostic shorting plug is installed</p>	<p>Remove the diagnostic shorting plug.</p>
<p>OK Go To Next Step</p>	
<p>STEP 2 Diagnostic switch is in the ON position</p>	<p>Turn off the diagnostic switch.</p>
<p>OK Go To Next Step</p>	
<p>STEP 3 Electronic fault codes are active</p>	<p>For instructions on how to read active fault codes, refer to Section 1. If fault codes are active, contact a Cummins Authorized Repair Facility.</p>
<p>OK Go To Next Step</p>	
<p>STEP 4 Contact a Cummins Authorized Repair Facility</p>	

Fault Code Warning Lamps Do Not Illuminate

Cause

Correction

STEP 1
Keyswitch is in the OFF position

Turn the keyswitch to the ON position.

OK

Go To Next Step

STEP 2
Battery voltage supply to the electronic control module (ECM) is low, interrupted, or open

Check the battery connections, the fuses, and the unswitched battery supply circuit. Refer to the OEM service manual.

OK

Go To Next Step

STEP 3
Idle shutdown or PTO shutdown features are activated

Check the time limit on idle and PTO shutdowns with an electronic service tool. Refer to Section 1.

OK

Go To Next Step

STEP 4
Contact a Cummins Authorized Repair Facility



Fuel Consumption Excessive

Cause	Correction
<p style="text-align: center;">STEP 1 Operator technique is not correct</p> <p style="text-align: center;">OK Go To Next Step</p>	<p>Refer to Section 1, Operating Instructions.</p>
<p style="text-align: center;">STEP 2 Electronic fault codes are active</p> <p style="text-align: center;">OK Go To Next Step</p>	<p>For instructions on how to read active fault codes, refer to Section 1. If fault codes are active, contact a Cummins Authorized Repair Facility.</p>
<p style="text-align: center;">STEP 3 Fuel leak</p> <p style="text-align: center;">OK Go To Next Step</p>	<p>Check the fuel lines, fuel connections, and fuel filters for leaks. Check the fuel lines to the supply tanks. Refer to the OEM service manual.</p>
<p style="text-align: center;">STEP 4 Hubometer or odometer is miscalibrated</p> <p style="text-align: center;">OK Go To Next Step</p>	<p>Check the hubometer and odometer calibrations. Calibrate or replace the hubometer or odometer, if necessary. Calculate fuel consumption with new mileage figures.</p>
<p style="text-align: center;">STEP 5 Hour meter is miscalibrated</p> <p style="text-align: center;">OK Go To Next Step</p>	<p>Check the hour meter. Calibrate or replace the hour meter if necessary. Calculate fuel consumption with new figures.</p>
<p style="text-align: center;">STEP 6 Air intake or exhaust leaks</p> <p style="text-align: center;">OK Go To Next Step</p>	<p>Check for loose or damaged piping connections and missing pipe plugs. Check the turbocharger and exhaust manifold mounting. Refer to Section 3.</p>
<p style="text-align: center;">STEP 7 Air intake system restriction is above specification</p> <p style="text-align: center;">OK Go To Next Step</p>	<p>Check the air intake system for restriction. Clean or replace the air filter and inlet piping as necessary. Refer to Section 4.</p>
<p style="text-align: center;">STEP 8 Equipment and environmental factors are affecting fuel consumption</p> <p style="text-align: center;">OK Go To Next Step</p>	<p>Consider ambient temperatures, wind, tire size, axle alignment, routes, and use of aerodynamic aids when evaluating fuel consumption.</p>

Fuel Consumption Excessive

Cause

Correction

STEP 9
Lubricating oil level above specification

Check the oil level. Verify the oil pan capacity. Fill the system to the specified level. Refer to Section V.

OK

Go To Next Step

STEP 10
Contact a Cummins Authorized Repair Facility



Fuel in Coolant

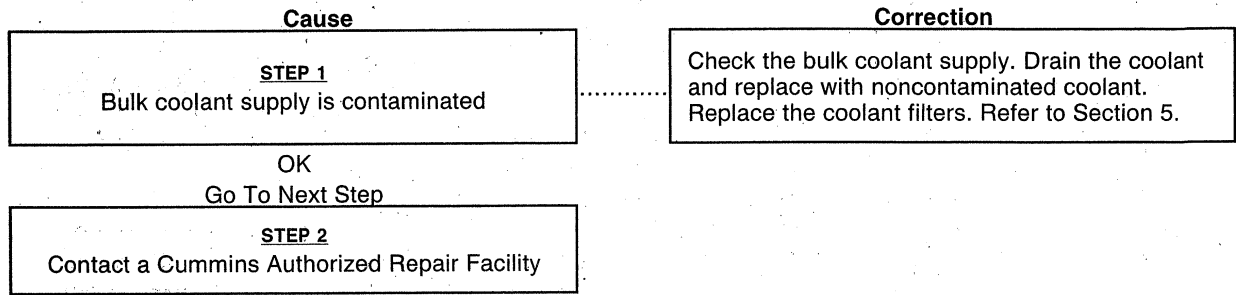

Fuel in the Lubricating Oil

Cause

Correction

STEP 1

Engine idle time is excessive

Low oil and coolant temperatures can be caused by long idle time (greater than 10 minutes). Shut off the engine rather than idle for long periods. If idle time is necessary, raise the idle speed.

OK

Go To Next Step

STEP 2

Bulk oil supply is contaminated

Check the bulk oil supply. Drain the oil and replace with noncontaminated oil. Replace the oil filter(s). Refer to Section 5.

OK

Go To Next Step

STEP 3

Contact a Cummins Authorized Repair Facility

Intake Manifold Air Temperature Above Specification

Cause	Correction
<p style="text-align: center;">STEP 1</p> <p>Charge air cooler fins, radiator fins, or air conditioner condenser fins are damaged or obstructed with debris</p> <p style="text-align: center;">OK Go To Next Step</p>	<p>Inspect the charge air cooler, air conditioner condenser, and radiator fins. Clean, if necessary. Refer to Section 4 and the OEM service manual.</p>
<p style="text-align: center;">STEP 2</p> <p>Cold weather radiator cover or winterfront is closed</p> <p style="text-align: center;">OK Go To Next Step</p>	<p>Open the cold weather radiator cover or the winterfront. Maintain a minimum of 387 cm² [60 in²] of opening at all times. Refer to Section 1.</p>
<p style="text-align: center;">STEP 3</p> <p>Fan drive belt or water pump belt is broken</p> <p style="text-align: center;">OK Go To Next Step</p>	<p>Check the fan drive belt and water pump belt. Replace the belts if necessary. Refer to Section A.</p>
<p style="text-align: center;">STEP 4</p> <p>Fan shroud is damaged or missing or the air recirculation baffles are damaged or missing</p> <p style="text-align: center;">OK Go To Next Step</p>	<p>Inspect the shroud and the recirculation baffles. Repair, replace, or install, if necessary. Refer to the OEM service manual.</p>
<p style="text-align: center;">STEP 5</p> <p>Radiator shutters are not opening completely or the shutterstat setting is wrong</p> <p style="text-align: center;">OK Go To Next Step</p>	<p>Inspect the radiator shutters. Repair or replace if necessary. Refer to the manufacturer's instructions. Check the shutterstat setting. Refer to the OEM service manual.</p>
<p style="text-align: center;">STEP 6</p> <p>Vehicle speed is too low for adequate cooling with high engine load</p> <p style="text-align: center;">OK Go To Next Step</p>	<p>Reduce the engine load. Increase the engine (fan) rpm by downshifting.</p>
<p style="text-align: center;">STEP 7</p> <p>Vehicle cooling system is not adequate</p> <p style="text-align: center;">OK Go To Next Step</p>	<p>Verify that the engine and vehicle cooling systems are using the correct components. Refer to the OEM vehicle specifications.</p>
<p style="text-align: center;">STEP 8</p> <p>Intake manifold temperature gauge is malfunctioning, if equipped</p> <p style="text-align: center;">OK Go To Next Step</p>	<p>Test the temperature gauge. Refer to the OEM service manual.</p>
<p style="text-align: center;">STEP 9</p> <p>Fan is not an adequate size for the application</p> <p style="text-align: center;">OK Go To Next Step</p>	<p>Verify that the fan is the correct size. Refer to the engine and OEM vehicle specifications.</p>

Intake Manifold Pressure (Boost) is Below Normal

Cause

Correction

STEP 1
Air intake or exhaust leaks

Check for loose or damaged piping connections and missing pipe plugs. Check the turbocharger and exhaust manifold mounting. Refer to Section 4.

OK
Go To Next Step

STEP 2
Air intake system restriction is above specification

Check the air intake system for restriction. Clean or replace the air filter and inlet piping as necessary. Refer to Section 4 and Section A.

OK
Go To Next Step

STEP 3
Charge air cooler is restricted or leaking

Inspect the charge air cooler for air restrictions or leaks. Refer to Section 4.

OK
Go To Next Step

STEP 4
Electronic fault codes are active

For instructions on how to read active fault codes, refer to Section 1. If fault codes are active, contact a Cummins Authorized Repair Facility.

OK
Go To Next Step

STEP 5
Engine power output is low

Refer to the Engine Power Output Low symptom tree.

OK
Go To Next Step

STEP 6
Contact a Cummins Authorized Repair Facility

Lubricating Oil Consumption Excessive

Cause	Correction
<p>STEP 1 Crankcase ventilation system is plugged</p>	<p>Check and clean the crankcase breather and vent tube. Refer to Section 3.</p>
<p>OK Go To Next Step</p>	
<p>STEP 2 Lubricating oil does not meet specifications for operating conditions</p>	<p>Change the oil and filters. Refer to Section 5. Use the oil recommended in Section V.</p>
<p>OK Go To Next Step</p>	
<p>STEP 3 Lubricating oil drain interval is excessive</p>	<p>Verify the correct lubricating oil drain interval. Refer to Section 2.</p>
<p>OK Go To Next Step</p>	
<p>STEP 4 Lubricating oil leak (external)</p>	<p>Inspect the engine for external oil leaks. Tighten the capscrews, pipe plugs, and fittings. Replace gaskets, if necessary. Refer to Section V for specifications.</p>
<p>OK Go To Next Step</p>	
<p>STEP 5 Verify the oil consumption rate</p>	<p>Check the amount of oil added versus the hours of operation.</p>
<p>OK Go To Next Step</p>	
<p>STEP 6 Air compressor is pumping lubricating oil into the air system</p>	<p>Check the air lines for carbon buildup and lubricating oil. Refer to a Cummins Authorized Repair Facility.</p>
<p>OK Go To Next Step</p>	
<p>STEP 7 Contact a Cummins Authorized Repair Facility</p>	

Lubricating Oil Contaminated

Cause	Correction
<p>STEP 1 Lubricating oil sludge is excessive</p>	<p>Change the oil and filters. Refer to the Lubricating Oil Sludge in the Crankcase Excessive symptom tree.</p>
<p>OK Go To Next Step</p>	
<p>STEP 2 Lubricating oil is contaminated with coolant or fuel</p>	<p>Change the oil and filters. Refer to Section 5. Use the oil recommended in Section V.</p>
<p>OK Go To Next Step</p>	
<p>STEP 3 Fuel lift pump is malfunctioning</p>	<p>Check the fuel lift pump for correct operation. Check the pump output pressure. Replace the fuel lift pump if necessary. Refer to an Authorized Cummins Repair Facility.</p>
<p>OK Go To Next Step</p>	
<p>STEP 4 Bulk oil supply is contaminated</p>	<p>Check the bulk oil supply. Drain the oil and replace with noncontaminated oil. Replace the oil filter(s). Refer to Section 5.</p>
<p>OK Go To Next Step</p>	
<p>STEP 5 Contact a Cummins Authorized Repair Facility</p>	

Lubricating Oil Loss

Cause	Correction
<p>STEP 1 Lubricating oil leak (external)</p>	<p>Inspect the engine for external oil leaks. Tighten the capscrews, pipe plugs, and fittings. Replace gaskets, if necessary. Refer to the OEM service manual.</p>
<p>OK Go To Next Step</p>	
<p>STEP 2 Lubricating oil level is below specification</p>	<p>Check the oil level. Verify the dipstick calibration and the oil pan capacity. Fill the system to the specified level. Refer to Section V.</p>
<p>OK Go To Next Step</p>	
<p>STEP 3 Lubricating oil does not meet specifications for operating conditions</p>	<p>Change the oil and filters. Refer to Section 5. Use the oil recommended in Section V.</p>
<p>OK Go To Next Step</p>	
<p>STEP 4 Lubricating oil pressure switch, gauge, or sensor is malfunctioning or is not in the correct location</p>	<p>Check the oil pressure switch, gauge, or sensor for correct operation and location. Refer to an Authorized Cummins Repair Facility.</p>
<p>OK Go To Next Step</p>	
<p>STEP 5 Electronic fault codes are active</p>	<p>For instructions on how to read active fault codes, refer to Section 1. If fault codes are active, contact a Cummins Authorized Repair Facility.</p>
<p>OK Go To Next Step</p>	
<p>STEP 6 Lubricating oil cooler is leaking</p>	<p>Check the lubricating oil cooler for coolant leaks and cracks. Refer to the OEM service manual or an Authorized Cummins Repair Facility.</p>
<p>OK Go To Next Step</p>	
<p>STEP 7 Air compressor is pumping lubricating oil into the air system</p>	<p>Check the air lines for carbon buildup and lubricating oil. Refer to the OEM service manual or an Authorized Cummins Repair Facility.</p>
<p>OK Go To Next Step</p>	
<p>STEP 8 Blowby excessive</p>	<p>Check for excessive blowby. Refer to the OEM service manual or an Authorized Cummins Repair Facility.</p>
<p>OK Go To Next Step</p>	

Lubricating Oil Loss

Cause

STEP 9
Turbocharger oil seal is leaking

OK
Go To Next Step

STEP 10
Contact a Cummins Authorized Repair Facility

Correction

Check the turbocharger for oil seals and for leaks. Refer to the Turbocharger Leaks Engine Oil or Fuel symptom tree.

Lubricating Oil Pressure High

Cause

Correction

<p>STEP 1 Coolant temperature is above specification</p>	<p>Refer to the Coolant Temperature Below Normal symptom tree.</p>
<p>OK Go To Next Step</p>		
<p>STEP 2 Lubricating oil does not meet specifications for operating conditions</p>	<p>Change the oil and filters. Refer to Section 5. Use the oil recommended in Section V.</p>
<p>OK Go To Next Step</p>		
<p>STEP 3 Lubricating oil pressure switch, gauge, or sensor is malfunctioning or is not in the correct location</p>	<p>Check the oil pressure switch, gauge, or sensor for correct operation and location. Refer to the OEM service manual.</p>
<p>OK Go To Next Step</p>		
<p>STEP 4 Electronic fault codes are active</p>	<p>For instructions on how to read active fault codes, refer to Section 1. If fault codes are active, contact a Cummins Authorized Repair Facility.</p>
<p>OK Go To Next Step</p>		
<p>STEP 5 Contact a Cummins Authorized Repair Facility</p>		



Lubricating Oil Pressure Low

Cause	Correction
<p>STEP 1 Engine angularity during operation exceeds specification</p>	<p>Refer to the Engine Data Sheet.</p>
<p>OK Go To Next Step</p>	
<p>STEP 2 Lubricating oil does not meet specifications for operating conditions</p>	<p>Change the oil and filters. Refer to Section 5. Use the oil recommended in Section V.</p>
<p>OK Go To Next Step</p>	
<p>STEP 3 Lubricating oil is diluted with water</p>	<p>Check for a missing dipstick, rain caps, or oil fill caps. Change the oil. Refer to the OEM service manual.</p>
<p>OK Go To Next Step</p>	
<p>STEP 4 Lubricating oil filter is plugged</p>	<p>Change the oil and filter. Refer to Section 5. Use the oil recommended in Section V.</p>
<p>OK Go To Next Step</p>	
<p>STEP 5 Lubricating oil is contaminated with coolant or fuel</p>	<p>Refer to the Lubricating Oil Contaminated symptom tree.</p>
<p>OK Go To Next Step</p>	
<p>STEP 6 Lubricating oil leak (external)</p>	<p>Inspect the engine for external oil leaks. Tighten the capscrews, pipe plugs, and fittings. Replace gaskets, if necessary. Refer to Section V for specifications.</p>
<p>OK Go To Next Step</p>	
<p>STEP 7 Lubricating oil level is above or below specification</p>	<p>Check the oil level. Add or drain oil, if necessary. Refer to Section 5. Use the oil recommended in Section V.</p>
<p>OK Go To Next Step</p>	
<p>STEP 8 Electronic fault codes are active</p>	<p>For instructions on how to read active fault codes, refer to Section 1. If fault codes are active, contact a Cummins Authorized Repair Facility.</p>
<p>OK Go To Next Step</p>	
<p>STEP 9 Lubricating oil pressure switch, gauge, or sensor is malfunctioning or is not in the correct location</p>	<p>Check the oil pressure switch, gauge, or sensor for correct operation and location. Refer to the OEM service manual.</p>
<p>OK Go To Next Step</p>	

Lubricating Oil Pressure Low

Cause

Correction

STEP 10

Contact a Cummins Authorized Repair Facility



Lubricating Oil Sludge in the Crankcase Excessive

Cause

Correction

STEP 1
Bulk oil supply is contaminated

Check the bulk oil supply. Drain the oil and replace with noncontaminated oil. Replace the oil filter(s). Refer to Section 5. Use the oil recommended in Section V.

OK
Go To Next Step

STEP 2
Coolant temperature is below specification

Refer to the Coolant Temperature Below Normal symptom tree.

OK
Go To Next Step

STEP 3
Crankcase ventilation system is plugged

Check and clean the crankcase breather and vent tube. Refer to Section 3.

OK
Go To Next Step

STEP 4
Fuel grade is **not** correct for the application or the fuel quality is poor

Operate the engine from a tank of high-quality fuel. Refer to Fuel Recommendations and Specifications in Section V.

OK
Go To Next Step

STEP 5
Lubricating oil does **not** meet specifications for operating conditions

Change the oil and filters. Refer to Section 5. Use the oil recommended in Section V.

OK
Go To Next Step

STEP 6
Contact a Cummins Authorized Repair Facility

Smoke, Black — Excessive

Cause

Correction

<p>STEP 1 Electronic fault codes are active</p>	<p>For instructions on how to read active fault codes, refer to Section 1. If fault codes are active, contact a Cummins Authorized Repair Facility.</p>
<p>OK Go To Next Step</p>	
<p>STEP 2 Air intake system restriction is above specification</p>	<p>Check the air intake system for restriction. Clean or replace the air filter and inlet piping as necessary. Refer to Section 4.</p>
<p>OK Go To Next Step</p>	
<p>STEP 3 Air intake or exhaust leaks</p>	<p>Check for loose or damaged piping connections and missing pipe plugs. Check the turbocharger and exhaust manifold mounting. Refer to Section 4.</p>
<p>OK Go To Next Step</p>	
<p>STEP 4 Charge air cooler is restricted or leaking</p>	<p>Inspect the charge air cooler for air restrictions or leaks. Refer to Section 4.</p>
<p>OK Go To Next Step</p>	
<p>STEP 5 Contact a Cummins Authorized Repair Facility</p>	



Smoke, White — Excessive

Cause	Correction
STEP 1 Starting procedure is not correct OK Go To Next Step	Verify the correct starting procedure. Refer to Section 1.
STEP 2 Engine is cold OK Go To Next Step	Allow the engine to warm to operating temperature. If the engine will not reach operating temperature, refer to the Coolant Temperature Below Normal symptom tree.
STEP 3 Engine is operating at low ambient temperature OK Go To Next Step	Check the winterfront, shutters, and under-the-hood air. Use under-the-hood intake air in cold weather. Refer to Cold Weather Operation, Bulletin 3387266, and Section 1.
STEP 4 Electronic fault codes are active OK Go To Next Step	For instructions on how to read active fault codes, refer to Section 1. If fault codes are active, contact a Cummins Authorized Repair Facility.
STEP 5 Starting aid is malfunctioning OK Go To Next Step	Check for correct operation of cold-starting aid. Refer to Cold Weather Starting Aids in Section 1. Refer to the manufacturer's instructions.
STEP 6 Coolant temperature is below specification OK Go To Next Step	Refer to the Coolant Temperature is Below Normal symptom tree.
STEP 7 Fuel grade is not correct for the application or the fuel quality is poor OK Go To Next Step	Operate the engine from a tank of high-quality fuel. Refer to Fuel Recommendations and Specifications in Section V.
STEP 8 Air intake or exhaust leaks OK Go To Next Step	Check for loose or damaged piping connections and missing pipe plugs. Check the turbocharger and exhaust manifold mounting. Refer to Section 4.

Smoke, White — Excessive

Cause

Correction

STEP 9
Air intake system restriction is above specification

Check the air intake system for restriction. Clean or replace the air filter and inlet piping as necessary. Refer to Section 3.

OK
Go To Next Step

STEP 10
Charge air cooler is restricted or leaking

Inspect the charge air cooler for air restrictions or leaks. Refer to Section 4.

OK
Go To Next Step

STEP 11
Contact a Cummins Authorized Repair Facility



Turbocharger Leaks Engine Oil or Fuel

Cause	Correction
<p>STEP 1 Engine is operating for extended periods under light or no-load conditions (slobbering)</p>	<p>Review the engine operating instructions. Refer to Section 1.</p>
OK	
Go To Next Step	
<p>STEP 2 Lubricating oil or fuel is entering the turbocharger</p>	<p>Remove the intake and exhaust piping, and check for oil or fuel. Refer to Section 3.</p>
OK	
Go To Next Step	
<p>STEP 3 Turbocharger oil drain line is restricted</p>	<p>Remove the turbocharger oil drain line and check for restriction. Clean or replace the oil drain line. Refer to an Authorized Cummins Repair Facility.</p>
OK	
Go To Next Step	
<p>STEP 4 Turbocharger oil supply line loose or leaking</p>	<p>Check and tighten oil supply line fitting(s), if necessary. Refer to an Authorized Cummins Repair Facility.</p>
OK	
Go To Next Step	
<p>STEP 5 Contact a Cummins Authorized Repair Facility</p>	

Section V - Maintenance Specifications

Section Contents

	Page
Air Intake System	V-5
Specifications.....	V-5
Capscrew Markings and Torque Values	V-18
Capscrew Markings and Torque Values - Metric.....	V-18
Capscrew Markings and Torque Values - U.S. Customary.....	V-18
General Information.....	V-18
Coolant Recommendations and Specifications	V-13
Cooling System Sealing Additives.....	V-14
Cooling System Soluble Oils.....	V-15
Fully Formulated Coolant/Antifreeze.....	V-13
Cooling System	V-4
Specifications.....	V-4
Cummins/Fleetguard® Filter Specifications	V-8
General Information.....	V-8
Drive Belt Tension	V-16
Tension Chart.....	V-16
Electrical System	V-7
Batteries (Specific Gravity).....	V-7
Specifications.....	V-7
Exhaust System	V-6
Specifications.....	V-6
Fuel Recommendations and Specifications	V-9
Fuel Recommendations.....	V-9
Fuel System	V-2
Preparatory Steps.....	V-2
General Engine	V-1
Specifications.....	V-1
Lubricating Oil Recommendations and Specifications	V-10
General Information.....	V-10
New Engine Break-in Oils.....	V-12
Lubricating Oil System	V-3
Specifications.....	V-3
Sealants	V-17
General Information.....	V-17

This Page Left Intentionally Blank

General Engine

Specifications

Listed below are the general specifications for this engine.

Horsepower.....	Refer to engine dataplate
Bore and Stroke.....	107 mm [4.21 in] X 124 mm [4.88 in]
Displacement (four-cylinder engine).....	4.5 liters [274 C.I.D.]
Displacement (six-cylinder engine).....	6.7 liters [409 C.I.D.]
Firing Order (four-cylinder engine).....	1-3-4-2
Firing Order (six-cylinder engine).....	1-5-3-6-2-4
Engine Weight (with standard accessories):	
Dry Weight for 4.5 Liters [274 C.I.D.].....	374 kg [825 lb]
Dry Weight for 6.7 Liters [409 C.I.D.].....	485 kg [1070 lb]
Crankshaft Rotation (viewed from the front of the engine).....	Clockwise
Valve Clearance:	
Intake.....	0.254 mm [0.010 in]
Exhaust.....	0.508 mm [0.020 in]

NOTE: The engine features a no-adjust overhead. The valve train is designed such that adjustment of the valve lash is **not** required for normal service during the first 241,402 km [150,000 mi, 5000 hr]. The valve train operates acceptably within the limits of 0.152- to 0.381-mm [0.006- to 0.015-in] intake valve lash and 0.381- to 0.762-mm [0.015- to 0.030-in] exhaust valve lash. It is recommended that the valve lash be checked around 241,402 km [150,000 mi, 5000 hr] and every 81,000 km [50,000 mi, 2000 hr] thereafter.



Fuel System

Preparatory Steps

For performance and fuel rate values, refer to the Engine Data Sheet

Maximum Fuel Inlet Restriction - With gear pump only (no engine mounted electric fuel lift pump) (at gear pump inlet)	50.7 kPa [15 in Hg]
Rail Pressure - 4.5 liters [275 C.I.D.] and 6.7 liters [409 C.I.D.]	250 to 1600 bar [3626 to 23,206 psi]
Fuel Pressure Range at Fuel Filter Inlet and Outlet (engine cranking) - With gear pump only (no electric fuel lift pump)	303 to 1103 kPa [44 to 160 psi]
Fuel Pressure Range at Fuel Filter Inlet and Outlet (engine running) - With gear pump only (no electric fuel lift pump)	503 to 1303 kPa [73 to 189 psi]
Maximum Pressure Drop across Fuel Filter - With gear pump only (no electric fuel lift pump)	200 kPa [29 psi]
Maximum Fuel Drain Line Restriction	19 kPa [2.7 psi]
Maximum Fuel Inlet Temperature	70°C [158°F]

Lubricating Oil System

Specifications

Oil Pressure:	
Low Idle (minimum allowed).....	103 kPa [15 psi]
At Rated Speed (minimum allowed).....	310 kPa [45 psi]
Regulated Pressure.....	414 kPa [60 psi]
Oil Capacity of Standard Engine:	
Standard	
Pan Only	14.2 liters [15 qt]
Total System	16.4 liters [17 qt]
Deep Sump	
Pan Only	17 liters [18 qt]
Total System.....	19.2 liters [20 qt]
Oil Pan High - Low	
Standard Pan.....	12 to 14.2 liters [13 to 15 qt]
Deep Sump Pan.....	15.1 to 17 liters [16 to 18 qt]

NOTE: Some applications use a slightly different lubricating oil pan capacity. You can also look up the exact capacity of your Lubricating Oil Pan on QuickServe OnLine® using your engine serial number. Contact your local Cummins Distributor if you have questions.



Cooling System

Specifications

Coolant Capacity (four-cylinder engine only).....	8.5 liters [2.2 gal]
Coolant Capacity (six-cylinder engine only).....	10 liters [2.6 gal]
Standard Modulating Thermostat — Range — Industrial Applications.....	88 to 97°C [190 to 207°F]
Maximum Allowed Operating Temperature — Industrial Applications.....	107°C [225°F]
Minimum Recommended Operating Temperature.....	71°C [160°F]
Minimum Recommended Pressure Cap — Industrial Applications.....	50 kPa [7 psi]

Air Intake System

Specifications

.....	.254 mm H ₂ O [10.0 in H ₂ O]
Maximum Intake Restriction (clean air filter element).....	.254 mm H ₂ O [10.0 in H ₂ O]
Maximum Intake Restriction (dirty air filter element).....	.635 mm H ₂ O [25.0 in H ₂ O]



Exhaust System

Specifications

Maximum Back Pressure measured at the turbocharger outlet (exhaust manifold outlet for naturally aspirated engines):

Without Exhaust Catalyst.....	10 kPa [1.5 psi]
With Exhaust Catalyst.....	15 kPa [2.2 psi]

Electrical System

Specifications

Recommended Battery Capacity

System Voltage	Ambient Temperature			
	-18°C [0°F]		-29°C [-20°F]	
	Cold Cranking Amperes	Reserve Capacity (minutes) ¹	Cold Cranking Amperes	Reserve Capacity (minutes) ¹
6 cylinder engines				
12 VDC	1500	260	1900	260
24 VDC ²	750	130	950	130
4 cylinder engines				
12 VDC	1200	260	1500	260
24 VDC ²	600	260	750	260

- ¹The number of plates within a given battery size determines reserve capacity. Reserve capacity is the length of time for which a battery at 27°C [81°F] can supply 25 amperes at 10.5 VDC or greater.

- ²Cold cranking amp(s)(CCA) ratings are based on two 12-VDC batteries in series.

Batteries (Specific Gravity)

Specific Gravity at 27°C [81°F]	State of Charge
1.260 to 1.280	100%
1.230 to 1.250	75%
1.200 to 1.220	50%
1.170 to 1.190	25%
1.110 to 1.130	Discharged

Cummins/Fleetguard® Filter Specifications

General Information

Fleetguard®/Nelson is a subsidiary of Cummins Inc. Fleetguard®/Nelson filters are developed through joint testing at Cummins and Fleetguard®/Nelson. Fleetguard®/Nelson filters are standard on new Cummins engines. Cummins Inc. recommends their use.

Fleetguard®/Nelson products meet all Cummins Source Approval Test standards to provide the quality filtration necessary to achieve the engine's design life. If other brands are substituted, the purchaser should insist on products that the supplier has tested to meet Cummins Inc. high-quality standards.

Cummins Inc. can **not** be responsible for problems caused by non-genuine filters that do **not** meet Cummins performance or durability requirements.

Filter Part Numbers

Lubricating oil filter	
Cummins Part Number	3937736
Fleetguard®/Nelson Part Number	LF3970

Fuel filter (Primary)	
Cummins Part Number	3978040
Fleetguard®/Nelson Part Number	FF5421

Fuel filter (Prefilter with WIF sensor)	
Cummins Part Number	3973233
Fleetguard®/Nelson Part Number	FS19732

Fuel Recommendations and Specifications

Fuel Recommendations



Do not mix gasoline, alcohol, or gasohol with diesel fuel. This mixture can cause an explosion.



Due to the precise tolerances of diesel injection systems, it is extremely important that the fuel be kept clean and free of dirt or water. Dirt or water in the system can cause severe damage to both the fuel pump and the fuel injectors.



Lighter fuels can reduce fuel economy or possibly damage fuel system components.

Cummins Inc. recommends the use of ASTM number 2D fuel. The use of number 2D diesel fuel will result in optimum engine performance.

At operating temperatures below 0°C [32°F], acceptable performance can be obtained by using blends of number 2D and number 1D.

The following chart lists acceptable substitute fuels for this engine.

Acceptable Substitute Fuels									
Number 1D Diesel (1) (2) (3)	Number 2D Diesel (3)	Number 1K Kerosene	Jet-A	Jet-A1	JP-5	JP-8	Jet-B	JP-4	CITE
A	OK	Not OK	A	A	A	A	Not OK	Not OK	Not OK
<ul style="list-style-type: none"> An "A" means OK only if fuel lubricity is adequate. This means the BOCLE number is 3100 or greater as measured by ASTM specification D6078, Scuffing Load Ball On Cylinder Evaluator (SLBOCLE). Lubricity can also be measured by ASTM, specification D6079, ISO 12156, High Frequency Reciprocating Rig (HFRR) in which the fuel must have a wear scar diameter of 0.45 mm [0.02 in] or less. Any adjustment to compensate for reduced performance with a fuel system using alternate fuel is not warrantable. Winter blend fuels, such as found at commercial fuel-dispensing outlets, are combinations of number 1D and 2D diesel fuels and are acceptable. 									

NOTE: Cummins Inc. recommends that the cetane number of diesel fuel be a minimum of 45 for engines that are expected to operate at temperatures below 0°C [32°F] and a minimum of 40 for engines that are operated at temperatures above 0°C [32°F].

NOTE: Using diesel fuel with lower than recommended cetane number can cause hard starting, instability, and excessive white smoke. To maintain satisfactory operation at low ambient temperatures, it is important to specify diesel fuel of the correct cetane number.

Additional information for fuel recommendations and specifications can be found in Fuel for Cummins Engines, Bulletin 3379001. See ordering information in the back of this manual.

Lubricating Oil Recommendations and Specifications

General Information

⚠CAUTION⚠

- The fuel sulphur content should not exceed 0.5 mass percent sulphur. If the fuel sulphur content is greater than 0.5 mass percent sulphur, seek advice from your local Cummins Distributor. For recommendations of fuel for Cummins engines, refer to Fuel for Cummins Engines, Bulletin 3379001 .
- Extending the oil and filter change interval beyond the recommendations will decrease engine life due to factors such as corrosion, deposits and wear.
- Cummins does not recommend the use of A.C.E.A. E4/MB 228.5 formulation oils, which do not attain one or more of the following lubricant qualifications: A.P.I. CH-4. CI-4, A.C.E.A. E5. E7, C.E.S. 20071, C.E.S. 20072, C.E.S. 20076, C.E.S. 20077, C.E.S. 20078.
- If A.C.E.A. E4/MB 228.5 formulation oils, which do not comply with the oil specifications listed above, are used in Cummins automotive engines, problems such as wear to overhead, sliding tappets, camshaft and crankshaft bearings may be experienced.

The use of quality engine lubricating oils, combined with appropriate oil drain and filter change intervals, is a critical factor in maintaining engine performance and durability. Extending the oil and filter change interval beyond the recommendations will decrease engine life due to factors such as corrosion, deposits and wear.

NOTE: The responsibility is with the owner. If recommendations are ignored, warranty could be affected.

NOTE: A.C.E.A. = Association des Constructeurs Européen d'Automobiles, A.P.I. = American Petroleum Institute and C.E.S. = Cummins Engineering Standard.

Cummins Inc. recommends the use of a high-quality SAE 15W-40 heavy-duty engine oil, such as Valvoline Premium Blue®, which meets or exceeds the American Petroleum Institute (API) performance classification CH-4/SJ or CI-4/SK and the Association des Constructeurs Européen d'Automobiles (A.C.E.A.) performance classification E5 or E7.

Cummins Engine Standard Classifications (CES)	American Petroleum Institute Classification (API)	European Classification (ACEA)	Comments
	API CD API CE	ACEA E-1, ACEA E-2	OBSOLETE. DO NOT USE.
CES-20075	API CF-4/SG, API CG-4/SH	ACEA E-3	Minimum acceptable oil classification for Midrange engines. ⁽¹⁾
CES-20071, CES-20072, CES-20076, CES-20077	API CH-4/SJ	ACEA E-5, E-7	Good oil classification for Midrange engines without EGR.
CES-20078	API CI-4/SK		Excellent oil for Midrange engines.

1. CG-4/SH and E-3 oils can be used in areas where none of the recommended oils are available, but the oil drain interval **must** be reduced by one half of the interval given in the maintenance schedule. See the oil drain interval information in Section 2.

A sulfated ash limit of 1.0 mass percent is suggested for optimum valve and piston deposit, and oil consumption control. The sulfated ash **must not** exceed 1.85 mass percent.

Special "break-in" oils are **not** recommended for use in new or rebuilt Cummins engines. Use the same lubricating oil that will be used in normal engine operations.

Use of "synthetic engine oils" (those made with API group 3 or group 4 base stocks) is permitted subject to the same performance and viscosity limitations of petroleum (mineral) based engine oils. The same oil change intervals **must** be applied to synthetic oils that are applied to petroleum (mineral) based engine oils.

For further details and discussion of engine lubricating oils for Cummins engines, refer to Cummins Engine Oil Recommendations, Bulletin 3810340.

QSB Series
Section V - Maintenance Specifications

Cummins' primary recommendation is for the use of 15W-40 multigrade for normal operation at ambient temperatures above -15°C [5°F]. The use of multigrade oil reduces deposit formation, improves engine cranking in low temperature conditions and increases engine durability by maintaining lubrication during high temperature operating conditions. Since multigrade oils have been shown to provide approximately 30 percent lower oil consumption, compared with monograde oils, it's important to use multigrade oils to be certain your engine will meet applicable emissions requirements. While the preferred viscosity grade is 15W-40, lower viscosity multigrades can be used in colder climates. See the accompanying chart.

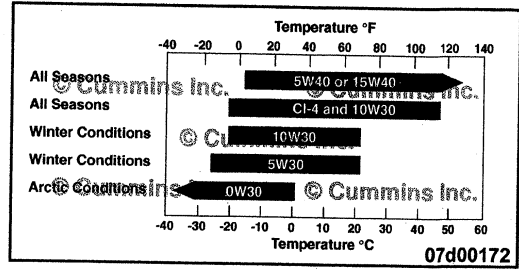

07d00172

Oils meeting a 10W30 viscosity grade, **must** meet a minimum High Temperature/High Shear viscosity of 3.5 cSt., and ring wear/liner wear requirements of Cummins and Mack tests. Thus, they can be used over a wider temperature range than 10W30 oils meeting older API performance classifications. As these oils will have directionally thinner oil films than 15W40 oils, top quality Fleetguard® filters **must** be used above 20°C [70°F]. Some oil suppliers might claim better fuel economy for these oils. Cummins can neither approve nor disapprove any product **not** manufactured by Cummins Inc. These claims are between the customer and oil supplier. Obtain the oil supplier's commitment that the oil will give satisfactory performance in Cummins' engines or do **not** use the oil.

⚠CAUTION⚠

An SAE 10W30 designation on a product is a viscosity designation only. This designation alone does not imply that the product meets Cummins requirements. Only 10W30 oils with diesel performance credentials listed in table above can be used in Cummins Engines if the reduced ambient temperature indicated in chart above is observed.

An example of the API service symbols are shown in the accompanying illustration. The upper half of the symbol displays the appropriate oil categories.

The center section identifies the SAE oil viscosity grade.

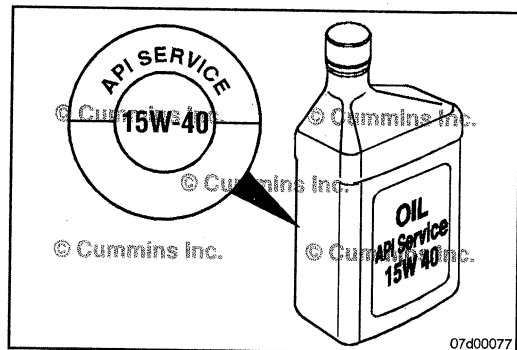

07d00077

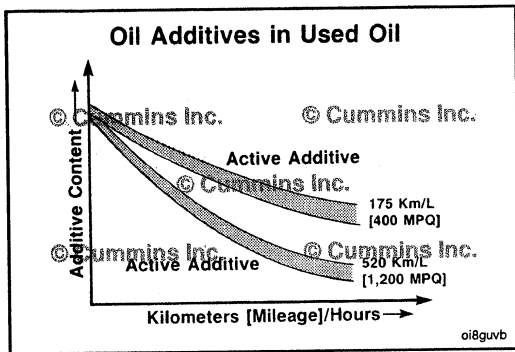

As the engine oil becomes contaminated, essential oil additives are depleted. Lubricating oils protect the engine as long as these additives are functioning properly. Progressive contamination of the oil between oil and filter change intervals is normal. The amount of contamination will vary depending on the operation of the engine, kilometers or miles on the oil, fuel consumed, and new oil added.

Extending oil and filter change intervals beyond the recommendations will decrease engine life due to factors such as corrosion, deposits, and wear.

See the oil drain chart in Section 2 to determine which oil drain interval to use for your application.

New Engine Break-in Oils

Special break-in engine lubricating oils are **not** recommended for new or rebuilt Cummins engines. Use the same type of oil during the break-in as is used in normal operation.

Additional information regarding lubricating oil availability throughout the world is available in the EMA Lubricating Oils Data Book for Heavy-Duty Automotive and Industrial Engines. The data book can be ordered from: Engine Manufacturers Association, Two North LaSalle Street, Chicago, IL 60602; (312) 827-8733, (www.enginemanufacturers.org).

⚠CAUTION⚠

A sulfated ash limit of 1.85 percent has been placed on all engine lubricating oils recommended for use in Cummins engines. Higher ash oils can cause valve and/or piston damage and lead to excessive oil consumption.

⚠CAUTION⚠

The use of a synthetic-base oil does not justify extended oil change intervals. Extended oil change intervals can decrease engine life due to factors such as corrosion, deposits, and wear.

Coolant Recommendations and Specifications

Fully Formulated Coolant/Antifreeze

Cummins Inc. recommends the use of fully formulated antifreeze/coolant meeting Cummins Engineering Standards (C.E.S.) 14603. For further details and discussion of coolant for Cummins® engines, refer to Coolant Requirements and Maintenance, Bulletin 3666132.

Typically, antifreeze/coolants meeting ASTM4985 (GM6038M specification) or ASTM D6210 criteria are acceptable antifreeze/coolants for engines covered by the manual.

Low-silicate antifreeze/coolants meeting ASTM D4985 (GM6038M specification) are **not** adequate for extended service intervals.

Cummins Inc. recommends using either a 50/50 mixture of good-quality water and fully formulated antifreeze, or fully formulated coolant when filling the cooling system.

Good-quality water is important for cooling system performance. Excessive levels of calcium and magnesium contribute to scaling problems, and excessive levels of chlorides and sulfates cause cooling system corrosion.

Water Quality	
Calcium Magnesium (hardness)	Maximum 170 ppm as (CaCO ₃ + MgCO ₃)
Chloride	40 ppm as (Cl)
Sulfur	100 ppm as (SO ₄)

Cummins Inc. recommends using Fleetguard® Compleat. It is available in both glycol forms (ethylene and propylene).

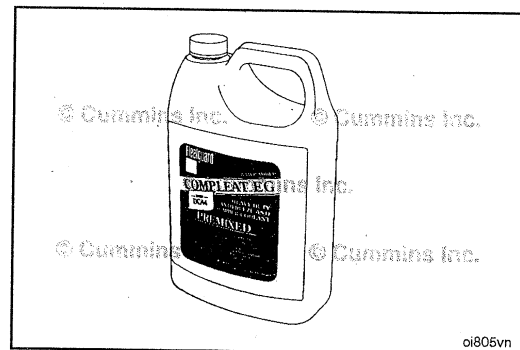
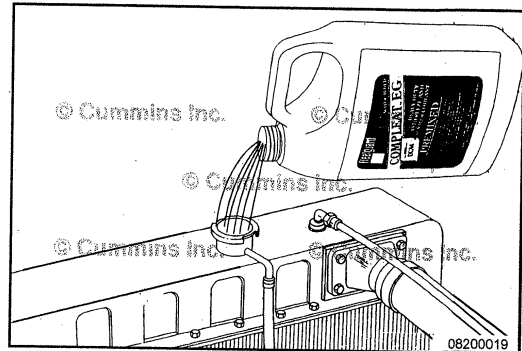

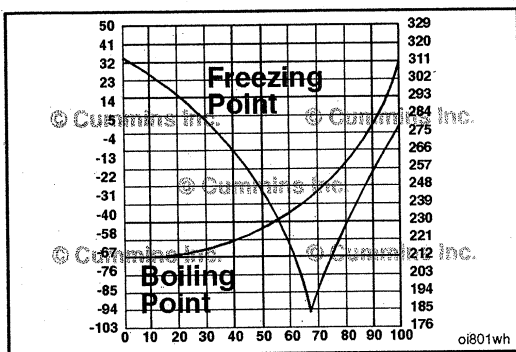

Fully formulated antifreeze **must** be mixed with good-quality water at a 50/50 ratio (40- to 60-percent working range). A 50/50 mixture of antifreeze and water gives a -36°C [-33°F] freezing point and a 108°C [226°F] boiling point, which is adequate for locations in North America. The actual lowest freezing point of ethylene glycol antifreeze is at 68 percent. Using higher concentrations of antifreeze will raise the freezing point of the solution and increase the possibility of a silica gel problem.

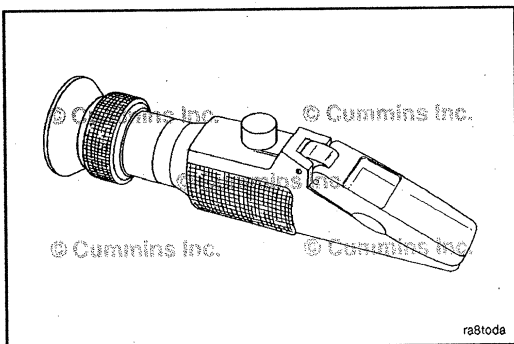

A refractometer **must** be used to measure the freezing point of the coolant **accurately**. Use Fleetguard® refractometer, Part Number C2800.

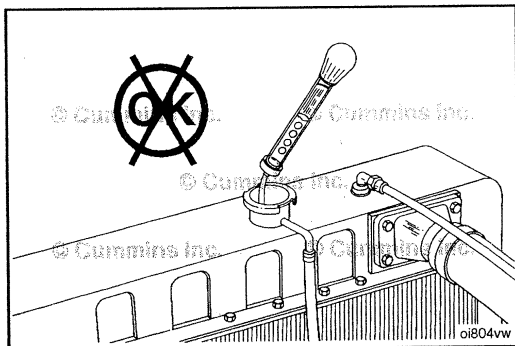

Do **not** use a floating ball hydrometer. The use of floating ball hydrometers can give an incorrect reading.

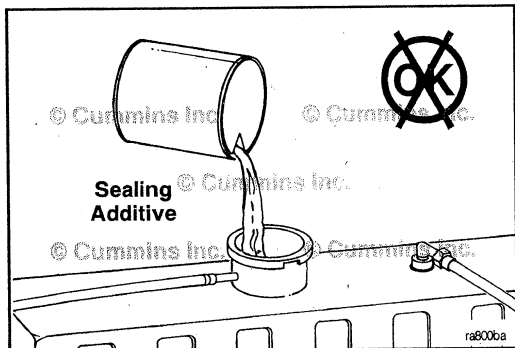

Cooling System Sealing Additives

Do **not** use sealing additives in the cooling system. The use of sealing additives will:

- Buildup in coolant low-flow areas
- Plug the radiator and oil cooler
- Possibly damage the water pump seal.

Cooling System Soluble Oils

Do **not** use soluble oils in the cooling system. The use of soluble oils will:

- Corrode brass and copper
- Damage heat transfer surfaces
- Damage seals and hoses.

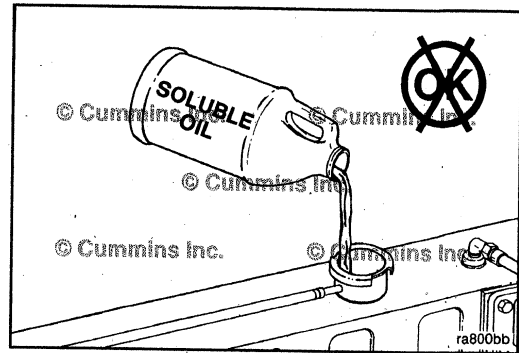

Drive Belt Tension

Tension Chart

SAE Belt Size	Belt Tension Gauge Part No.		Belt Tension New		Belt Tension Range Used*	
	Click-type	Burroughs	N	lbf	N	lbf
0.380 in	3822524		620	140	270 to 490	60 to 110
0.440 in	3822524		620	140	270 to 490	60 to 110
1/2 in	3822524	ST-1138	620	140	270 to 490	60 to 110
11/16 in	3822524	ST-1138	620	140	270 to 490	60 to 110
3/4 in	3822524	ST-1138	620	140	270 to 490	60 to 110
7/8 in	3822524	ST-1138	620	140	270 to 490	60 to 110
4 rib	3822524	ST-1138	620	140	270 to 490	60 to 110
5 rib	3822524	ST-1138	670	150	270 to 530	60 to 120
6 rib	3822525	ST-1293	710	160	290 to 580	65 to 130
8 rib	3822525	ST-1293	890	200	360 to 710	80 to 160
10 rib	3822525	3823138	1110	250	440 to 890	100 to 200
12 rib	3822525	3823138	1330	300	530 to 1070	120 to 240
12 rib K section	3822525	3823138	1330	300	890 to 1070	200 to 240

NOTE: This chart does not apply to automatic belt tensioners.

* A belt is considered used if it has been in service for ten minutes or longer.

* If used belt tension is less than the minimum value, tighten the belt to the maximum used belt value.

Sealants

General Information

Use the sealants listed below or sealants containing equivalent properties.

Item	Cummins Part Number	Generic Description
Pipe Plugs	3375066	Teflon Pipe Sealant
Cup Plugs	3375068	Sealant
O-Rings	3163087	Assembly Lube
Oil Pan T-Joint	3164067	RTV Sealant
Flywheel Housing to Rear Gear Housing Joint	3164070	RTV Sealant
Front Gear Cover to Block Joint	3164070	RTV Sealant
Rear Gear Housing to Block Joint	3164070	RTV Sealant
Intake Manifold to Cylinder Head Joint	3164070	RTV Sealant

Capscrew Markings and Torque Values

General Information

⚠CAUTION⚠

When replacing capscrews, always use a capscrew of the same measurement and strength as the capscrew being replaced. Using the wrong capscrews can result in engine damage.

Metric capscrews and nuts are identified by the grade number stamped on the head of the capscrew or on the surface of the nuts. U.S. Customary capscrews are identified by radial lines stamped on the head of the capscrew.

The following examples indicate how capscrews are identified:

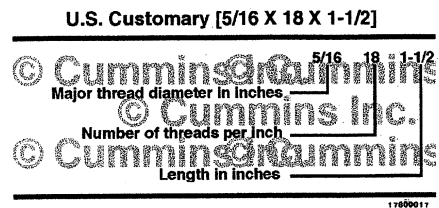
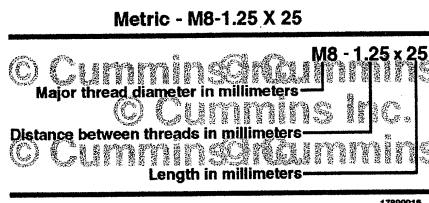





NOTES:

1. **Always** use the torque values listed in the following tables when specific torque values are **not** available.
2. Do **not** use the torque values in place of those specified in other sections of this manual.
3. The torque values in the table are based on the use of lubricated threads.
4. When the ft-lb value is less than 10, convert the ft-lb value to in-lb to obtain a better torque with an in-lb torque wrench. Example: 6 ft-lb equals 72 in-lb.

Capscrew Markings and Torque Values - Metric

Commercial Steel Class	8.8				10.9				12.9			
	Capscrew Head Markings											
Body Size	Torque				Torque				Torque			
Diameter	Cast Iron		Aluminum		Cast Iron		Aluminum		Cast Iron		Aluminum	
mm	N•m	ft-lb	N•m	ft-lb	N•m	ft-lb	N•m	ft-lb	N•m	ft-lb	N•m	ft-lb
6	9	5	7	4	13	10	7	4	14	9	7	4
7	14	9	11	7	18	14	11	7	23	18	11	7
8	23	17	18	14	33	25	18	14	40	29	18	14
10	45	33	30	25	65	50	30	25	70	50	30	25
12	80	60	55	40	115	85	55	40	125	95	55	40
14	125	90	90	65	180	133	90	65	195	145	90	65
16	195	140	140	100	280	200	140	100	290	210	140	100
18	280	200	180	135	390	285	180	135	400	290	180	135
20	400	290	—	—	550	400	—	—	—	—	—	—

Capscrew Markings and Torque Values - U.S. Customary

SAE Grade Number	5	8
Capscrew Head Markings		
These are all SAE Grade 5 (3 line)		

Capscrew Body Size	Capscrew Torque - Grade 5 Capscrew				Capscrew Torque - Grade 8 Capscrew			
	Cast Iron		Aluminum		Cast Iron		Aluminum	
	N•m	ft-lb	N•m	ft-lb	N•m	ft-lb	N•m	ft-lb
1/4 - 20	9	7	8	6	15	11	8	6
1/4 - 28	12	9	9	7	18	13	9	7
5/16 - 18	20	15	16	12	30	22	16	12
5/16 - 24	23	17	19	14	33	24	19	14
3/8 - 16	40	30	25	20	55	40	25	20
3/8 - 24	40	30	35	25	60	45	35	25
7/16 - 14	60	45	45	35	90	65	45	35
7/16 - 20	65	50	55	40	95	70	55	40
1/2 - 13	95	70	75	55	130	95	75	55
1/2 - 20	100	75	80	60	150	110	80	60
9/16 - 12	135	100	110	80	190	140	110	80
9/16 - 18	150	110	115	85	210	155	115	85
5/8 - 11	180	135	150	110	255	190	150	110
5/8 - 18	210	155	160	120	290	215	160	120
3/4 - 10	325	240	255	190	460	340	255	190
3/4 - 16	365	270	285	210	515	380	285	210
7/8 - 9	490	360	380	280	745	550	380	280
7/8 - 14	530	390	420	310	825	610	420	310
1 - 8	720	530	570	420	1100	820	570	420
1 - 14	800	590	650	480	1200	890	650	480



Section W - Warranty

Section Contents

	Page
California Emission Control System Warranty, Off-Highway	W-6
All Engines International Industrial (Off-Highway)	W-4
All Engines United States and Canada Industrial (Off-Highway)	W-1



This Page Left Intentionally Blank

All Engines United States and Canada Industrial (Off-Highway)

Coverage

Products Warranted

This warranty applies to new Engines sold by Cummins and delivered to the first user on or after April 1, 1999, that are used in industrial (off-highway) applications in the United States* and Canada, except for Engines used in marine, generator drive and certain defense applications, for which different warranty coverage is provided.

Base Engine Warranty

This warranty covers any failures of the Engine, under normal use and service, which result from a defect in material or factory workmanship (Warrantable Failures).

Coverage begins with the sale of the Engine by Cummins. Coverage continues for two years or 2,000 hours of operation, whichever occurs first, from the date of delivery of the Engine to the first user, or from the date the unit is first leased, rented or loaned, or when the Engine has been operated for 50 hours, whichever occurs first. If the 2,000 hour limit is exceeded during the first year, Coverage continues until the end of the first year.

Extended Major Components Warranty

The Extended Major Components Warranty covers Warrantable Failures of the Engine cylinder block, camshaft, crankshaft and connecting rods (Covered Parts).

Bushing and bearing failures are not covered.

This Coverage begins with the expiration of the Base Engine Warranty and ends three years or 10,000* hours of operation from the date of delivery of the Engine to the first user, or from the date the unit is first leased, rented or loaned, or from when the Engine has been operated for 50 hours, whichever occurs first.

*3,000 hours for A series engines.

Consumer Products

The warranty on Consumer Products in the United States is a LIMITED warranty. **CUMMINS IS NOT RESPONSIBLE FOR INCIDENTAL OR CONSEQUENTIAL DAMAGES.** Any implied warranties applicable to Consumer Products in the United States terminate concurrently with the expiration of the express warranties applicable to the product. In the United States, some states do not allow the exclusion of incidental or consequential damages, or limitations on how long an implied warranty lasts, so the limitations or exclusions herein may not apply to you.

These warranties are made to all Owners in the chain of distribution, and Coverage continues to all subsequent Owners until the end of the periods of Coverage.

Cummins' Responsibilities

During The Base Engine Warranty

Cummins will pay for all parts and labor needed to repair the damage to the Engine resulting from a Warrantable Failure.

Cummins will pay for the lubricating oil, antifreeze, filter elements, and other maintenance items that are not reusable due to the Warrantable Failure.

Cummins will pay reasonable costs for mechanics to travel to and from the equipment site, including meals, mileage and lodging, when the repair is performed at the site of the failure.

Cummins will pay reasonable labor costs for Engine removal and reinstallation when necessary to repair a Warrantable Failure.

During The Extended Major Components Warranty

Cummins will pay for the repair or, at its option, replacement of the defective Covered Part and any Covered Part damaged by a Warrantable Failure of the defective Covered part.

Owner's Responsibilities

During The Base Engine Warranty

Owner is responsible for the cost of lubricating oil, antifreeze, filter elements and other maintenance items provided during warranty repairs unless such items are not reusable due to the Warrantable Failure.

During The Extended Major Components Warranty

Owner is responsible for the cost of all labor needed to repair the Engine, including the labor to remove and reinstall the Engine. When Cummins elects to repair a part instead of replacing it, Owner is not responsible for the labor needed to repair the part.

Owner is responsible for the cost of all parts required for the repair except for the defective Covered Part and any Covered Part damaged by a Warrantable Failure of the defective Covered Part.

Owner is responsible for the cost of lubricating oil, antifreeze, filter elements and other maintenance items replaced during repair of a Warrantable Failure.

During The Base Engine and Extended Major Components Warranties

Owner is responsible for the operation and maintenance of the Engine as specified in the applicable Cummins Operation and Maintenance Manual. Owner is also responsible for providing proof that all recommended maintenance has been performed.

Before the expiration of the applicable warranty, Owner must notify a Cummins distributor, authorized dealer or other repair location approved by Cummins of any Warrantable Failure and make the Engine available for repair by such facility. Locations in the United States and Canada are listed in the Cummins Off Highway Authorized Dealer Directory.

Owner is responsible for communication expenses, meals, lodging and similar costs incurred as a result of a Warrantable Failure.

Owner is responsible for non-Engine repairs, "downtime" expenses, cargo damage, fines, all applicable taxes, all business costs and other losses resulting from a Warrantable Failure.

Limitations

Cummins is not responsible for failures or damage resulting from what Cummins determines to be abuse or neglect, including, but not limited to: operation without adequate coolants or lubricants; overfueling; overspeeding; lack of maintenance of lubricating, cooling or intake systems; improper storage, starting, warm-up, run-in or shutdown practices; unauthorized modifications of the Engine. Cummins is also not responsible for failures caused by incorrect oil or fuel or by water, dirt or other contaminants in the fuel or oil.

For power units and fire pumps (package units), this warranty applies to accessories, except for clutches and filters, supplied by Cummins which bear the name of another company.

Except for power units and fire pumps, this warranty does not apply to accessories which bear the name of another company. Such non-warranted accessories include, but are not limited to: alternators, starters, fans** , air conditioning compressors, clutches, filters, transmissions, torque converters, steering pumps, and non-Cummins fan drives, engine compression brakes and air compressors.

Cummins CompuSave units are covered by a separate warranty.

Before a claim for excessive oil consumption will be considered, Owner must submit adequate documentation to show that consumption exceeds Cummins published standards.

Failures of belts and hoses supplied by Cummins are not covered beyond the first 500 hours or one year of operation, whichever occurs first.

Parts used to repair a Warrantable Failure may be new Cummins parts, Cummins-approved rebuilt parts, or repaired parts. Cummins is not responsible for failures resulting from the use of parts not approved by Cummins.

A new Cummins or Cummins-approved rebuilt part used to repair a Warrantable Failure assumes the identity of the part it replaced and is entitled to the remaining coverage hereunder.

CUMMINS DOES NOT COVER WEAR OR WEAROUT OF COVERED PARTS.

CUMMINS IS NOT RESPONSIBLE FOR INCIDENTAL OR CONSEQUENTIAL DAMAGES.

THESE WARRANTIES SET FORTH HEREIN ARE THE SOLE WARRANTIES MADE BY CUMMINS IN REGARD TO THESE ENGINES. CUMMINS MAKES NO OTHER WARRANTIES, EXPRESS OR IMPLIED, OR OF MERCHANTABILITY OR FITNESS FOR A PARTICULAR PURPOSE.

This warranty gives you specific legal rights, and you may also have other rights which vary from state to state.

Emission Warranty

Products Warranted

This emission warranty applies to new Engines marketed by Cummins that are used in the United States* in vehicles designed for Industrial off-highway use. This warranty applies to Engines delivered to the ultimate purchaser on or after April 1, 1999 for engines up to 750 horsepower, on or after January 1, 2000 for engines 751 horsepower and over.

Coverage

Cummins warrants to the ultimate purchaser and each subsequent purchaser that the Engine is designed, built and equipped so as to conform at the time of sale by Cummins with all U.S. Federal emission regulations applicable at the time of manufacture and that it is free from defects in workmanship or material which would cause it not to meet these regulations within the longer of the following periods: (A) Five years or 3,000 hours of operation, whichever

occurs first, as measured from the date of delivery of the Engine to the ultimate purchaser, or (B) The Base Engine Warranty.

If the vehicle in which the Engine is installed is registered in the state of California, a separate California Emission Warranty also applies.

Limitations

Failures, other than those resulting from defects in materials, or workmanship, are not covered by this warranty.

Cummins is not responsible for failures or damage resulting from what Cummins determines to be abuse or neglect, including, but not limited to: operation without adequate coolant or lubricants; overfueling; overspeeding; lack of maintenance of lubricating, cooling or intake systems; improper storage, starting, warm-up, run-in or shutdown practices; unauthorized modifications of the Engine. Cummins is also not responsible for failures caused by incorrect fuel or by water, dirt or other contaminants in the fuel.

Cummins is not responsible for non-Engine repairs, "downtime" expenses, cargo damage, fines, all business costs or other losses resulting from a Warrantable Failure.

CUMMINS IS NOT RESPONSIBLE FOR INCIDENTAL OR CONSEQUENTIAL DAMAGES.

* Includes American Samoa, the Commonwealth of Northern Mariana Islands, Guam, Puerto Rico, and the U.S. Virgin Islands.

** Alternators, starters, and fans ARE covered for the duration of the base engine warranty on A series and B3.3 engines.

All Engines International Industrial (Off-Highway)

Coverage

PRODUCTS WARRANTED

This warranty applies to new Engines sold by Cummins and delivered to the first user on or after April 1, 1999, that are used in industrial (off-highway) applications anywhere in the world where Cummins-approved service is available, except the United States* and Canada. Different warranty coverage is provided for Engines used in marine, generator drive and certain defense applications.

BASE ENGINE WARRANTY

This warranty covers any failures of the Engine, under normal use and service, which result from a defect in material or factory workmanship (Warrantable Failure).

Coverage begins with the sale of the Engine by Cummins. Coverage continues for two years or 2,000 hours of operation, whichever occurs first, from the date of delivery of the Engine to the first user, or from the date the unit is first leased, rented or loaned, or when the Engine has been operated for 50 hours, whichever occurs first. If the 2,000 hour limit is exceeded during the first year, coverage continues until the end of the first year.

EXTENDED MAJOR COMPONENTS WARRANTY

The Extended Major Components Warranty covers Warrantable Failures of the Engine cylinder block, camshaft, crankshaft and connecting rods (Covered Parts).

Bushing and bearing failures are not covered.

This coverage begins with the expiration of the Base Engine Warranty and ends three years or 10,000* hours of operation, from the date of delivery of the Engine to the first user, or from the date the unit is first leased, rented or loaned, or when the Engine has been operated for 50 hours, whichever occurs first.

*3,000 hours for A series engines.

These warranties are made to all Owners in the chain of distribution, and Coverage continues to all subsequent Owners until the end of the periods of Coverage.

Cummins' Responsibilities

DURING THE BASE ENGINE WARRANTY

Cummins will pay for all parts and labor needed to repair the damage to the Engine resulting from a Warrantable Failure.

Cummins will pay for the lubricating oil, antifreeze, filter elements, and other maintenance items that are not reusable due to a Warrantable Failure.

Cummins will pay reasonable costs for mechanics to travel to and from the equipment site, including meals, mileage and lodging, when the repair is performed at the site of the failure.

Cummins will pay reasonable labor costs for Engine removal and reinstallation when necessary to repair a Warrantable Failure.

DURING THE EXTENDED MAJOR COMPONENTS WARRANTY

Cummins will pay for the repair or, at its option, replacement of the defective Covered Part and any Covered Part damaged by a Warrantable Failure of the defective Covered part.

Owner's Responsibilities

DURING THE BASE ENGINE WARRANTY

Owner is responsible for the cost of lubricating oil, antifreeze, filter elements and other maintenance items replaced during warranty repairs unless such items are not reusable due to the Warrantable Failure.

DURING THE EXTENDED MAJOR COMPONENTS WARRANTY

Owner is responsible for the cost of all labor needed to repair the Engine, including the labor to remove and reinstall the Engine. When Cummins elects to repair a part instead of replacing it, Owner is not responsible for the labor needed to repair the part.

Owner is responsible for the cost of all parts required for the repair except for the defective Covered Part and any Covered Part damaged by a Warrantable Failure of the defective Covered Part.

Owner is responsible for the cost of lubricating oil, antifreeze, filter elements and other maintenance items replaced during repair of a Warrantable Failure.

DURING THE BASE ENGINE AND EXTENDED MAJOR COMPONENTS WARRANTIES

Owner is responsible for the operation and maintenance of the Engine as specified in the applicable Cummins Operation and Maintenance Manual. Owner is also responsible for providing proof that all recommended maintenance has been performed.

Before the expiration of the applicable warranty, Owner must notify a Cummins distributor, authorized dealer or other repair location approved by Cummins of any Warrantable Failure and make the product available for repair by such facility. Locations are listed in the Cummins International Sales and Service Directory.

Owner is responsible for communication expenses, meals, lodging and similar costs incurred as a result of a Warrantable Failure.

Owner is responsible for non-Engine repairs, "downtime" expenses, cargo damage, fines, all applicable taxes, all business costs and other losses resulting from a Warrantable Failure.

Limitations

Cummins is not responsible for failures or damage resulting from what Cummins determines to be abuse or neglect, including, but not limited to: operation without adequate coolants or lubricants; overfueling; overspeeding; lack of maintenance of lubricating, cooling or intake systems; improper storage, starting, warm-up, run-in or shutdown practices; unauthorized modifications of the Engine. Cummins is also not responsible for failures caused by incorrect oil or fuel or by water, dirt or other contaminants in the fuel or oil.

For power units and fire pumps (package units) the warranty applies to accessories, except for clutches and filters supplied by Cummins which bear the name of another company.

Non-Cummins starters, alternators, power steering pumps and air compressors supplied by Cummins that are not supplied as part of a package unit are covered for six months from the date of delivery of the Engine to the first user, or from the date the unit is first leased, rented or loaned, or when the Engine has been operated for 50 hours, whichever occurs first. Cummins branded parts noted above supplied by Cummins are covered for the entire Base Warranty period.

Except for the accessories noted previously, Cummins does not warrant accessories which bear the name of another company. Such non-warranted accessories include, but are not limited to: alternators, starters, fans*, air conditioning compressors, clutches, filters, transmissions, torque converters, steering pumps, non-Cummins fan drives, and air cleaners.

Cummins Compusave units are covered by a separate warranty.

Before a claim for excessive oil consumption will be considered, Owner must submit adequate documentation to show that consumption exceeds Cummins published standards.

Failures of belts and hoses supplied by Cummins are not covered beyond the first 500 hours or one year of operation, whichever occurs first.

Parts used to repair a Warrantable Failure may be new Cummins parts, Cummins-approved rebuilt parts, or repaired parts. Cummins is not responsible for failures resulting from the use of parts not approved by Cummins.

A new Cummins or Cummins-approved rebuilt part used to repair a Warrantable Failure assumes the identity of the part it replaced and is entitled to the remaining coverage hereunder.

CUMMINS DOES NOT COVER WEAR OR WEAROUT OF COVERED PARTS.

CUMMINS IS NOT RESPONSIBLE FOR INCIDENTAL OR CONSEQUENTIAL DAMAGES.

THESE WARRANTIES SET FORTH HEREIN ARE THE SOLE WARRANTIES MADE BY CUMMINS IN REGARD TO THESE ENGINES. CUMMINS MAKES NO OTHER WARRANTIES, EXPRESS OR IMPLIED, OR OF MERCHANTABILITY OR FITNESS FOR A PARTICULAR PURPOSE.

In case of consumer sales, in some countries, the Owner has statutory rights which cannot be affected or limited by the terms of this warranty.

Nothing in this warranty excludes or restricts any contractual rights the Owner may have against third parties.

* Alternators, starters, and fans ARE covered for the duration of the base engine warranty on A series and B3.3 engines.

California Emission Control System Warranty, Off-Highway

Products Warranted

This Emission Control System Warranty applies to off-road diesel engines certified with the California Air Resources Board beginning with the year 1996 for engines up to 750 horsepower, beginning with the year 2000 for 751 horsepower and over, marketed by Cummins, and registered in California for use in industrial off-highway applications.

Your Warranty Rights and Obligations

The California Air Resources Board and Cummins Engine Company, Inc., are pleased to explain the emission control system warranty on your engine. In California, new off-road diesel engines must be designed, built and equipped to meet the State's stringent anti-smog standards. Cummins must warrant the emission control system on your engine for the periods of time listed below provided there has been no abuse, neglect or improper maintenance of your engine.

Your emission control system may include parts such as the fuel injection system and the air induction system. Also included may be hoses, belts, connectors and other emission-related assemblies.

Where a warrantable condition exists, Cummins will repair your off-road diesel engine at no cost to you including diagnosis, parts and labor.

Manufacturer's Warranty Coverage

This warranty coverage is provided for 5 years or 3,000 hours of engine operation, whichever first occurs from the date of delivery of the engine to the first user. If any emission-related part on your engine is defective, the part will be repaired or replaced by Cummins.

Coverage

This emission control system warranty applies only to the following A series, B3.3, B3.9, B4.5^s, B5.9, B6.7^s, QSB3.9-30, QSB4.5-30, QSB5.9-30, QSB5.9-44, C8.3, QSC8.3, and QSL9 emission control parts:

Fuel Pump

Static Timing
Delivery Valve
Injection Control Valve Module

Injectors

Calibration
Needle
Nozzle
Spring

Turbocharger

Compressor Wheel
Turbine Wheel
Turbine Oil Seal
Wastegate Valve

Intake Manifold

Charge Air Cooler
Aftercooler

Exhaust Manifold

Oxidation Catalyst

Electronic Control System

Control Module
Boost Pressure Sensor
Coolant Temperature Sensor
Fuel Pressure Sensor



Owner's Warranty Responsibilities

As the off-road diesel engine owner, you are responsible for the performance of the required maintenance listed in your Cummins Operation and Maintenance Manual. Cummins recommends that you retain all receipts covering maintenance on your off-road diesel engine, but Cummins cannot deny warranty solely for the lack of receipts or for your failure to ensure the performance of all scheduled maintenance.

You are responsible for presenting your off-road diesel engine to a Cummins dealer as soon as a problem exists. The warranty repairs should be completed in a reasonable amount of time, not to exceed 30 days.

As the off-road diesel engine owner, you should also be aware that Cummins may deny you warranty coverage if your off-road diesel engine or a part has failed due to abuse, neglect, improper maintenance or unapproved modifications.

Your engine is designed to operate on diesel fuel only. Use of any other fuel may result in your engine no longer operating in compliance with California's emissions requirements.

If you have any questions regarding your warranty rights and responsibilities, you should contact Cummins Customer Assistance Department at 1-800-343-7357 (1-800-DIESELS) or the California Air Resources Board at 9528 Telstar Avenue, El Monte, CA 91731.

Prior to the expiration of the applicable warranty, Owner must give notice of any warranted emission control failure to a Cummins distributor, authorized dealer or other repair location approved by Cummins and deliver the engine to such facility for repair. Repair locations are listed in Cummins United States and Canada Service Directory.

Owner is responsible for incidental costs such as: communication expenses, meals, lodging incurred by Owner or employees of Owner as a result of a warrantable failure.

Owner is responsible for business costs and losses, "downtime" expenses, and cargo damage resulting from a warrantable failure. CUMMINS IS NOT RESPONSIBLE FOR OTHER INCIDENTAL OR CONSEQUENTIAL DAMAGES, INCIDENTAL OR CONSEQUENTIAL DAMAGES INCLUDE BUT ARE NOT LIMITED TO FINES, THEFT, VANDALISM OR COLLISIONS.

Replacement Parts

Cummins recommends that any service parts used for maintenance, repair or replacement of emission control systems be new, genuine Cummins or Cummins approved rebuilt parts and assemblies, and that the engine be serviced by a Cummins distributor, authorized dealer or the repair location approved by Cummins. The owner may elect to have maintenance, replacement or repair of the emission control parts performed by a facility other than a Cummins distributor, an authorized dealer or a repair location approved by Cummins, and may elect to use parts other than new genuine Cummins or Cummins approved rebuilt parts and assemblies for such maintenance, replacement or repair; however, the cost of such service or parts will not be covered under this emission control system warranty.

Cummins Responsibilities

Repairs and service will be performed by any Cummins distributor, authorized dealer or other repair location approved by Cummins using new, genuine Cummins or Cummins approved rebuilt parts and assemblies. Cummins will repair any of the emission control parts found by Cummins to be defective without charge for parts or labor (including diagnosis which results in determination that there has been a failure of a warranted emission control part).

Emergency Repairs

In the case of an emergency where a Cummins distributor, authorized dealer, or other repair location approved by Cummins is not available, repairs may be performed by any available repair location using any replacement parts. Cummins will reimburse the Owner for expenses (including diagnosis), not to exceed the manufacturer's suggested retail price for all warranted parts replaced and labor charges based on the manufacturer's recommended time allowance for the warranty repair and the geographically appropriate hourly labor rate. A part not being available within 30 days or a repair not being complete within 30 days constitutes an emergency. Replaced parts and paid invoices must be presented at a Cummins authorized repair facility as a condition of reimbursement for emergency repairs not performed by a Cummins distributor, authorized dealer, or other repair location approved by Cummins.

Warranty Limitations

Cummins is not responsible for failures resulting from Owner or operator abuse or neglect, such as: operation without adequate coolant, fuel or lubricants; overfueling; overspeeding; lack of maintenance of lubricating, cooling or air intake systems; improper storage, starting, warm-up, run-in or shutdown practices.

The manufacturer warrants to the ultimate purchaser and each subsequent purchaser that the engine is designed, built, and equipped so as to conform with all applicable regulations adopted by the Air Resources Board, and that it is free from defects in materials and workmanship which cause the failure of a warranted part.

Any warranted part which is not scheduled for replacement as required maintenance, or which is scheduled only for regular inspection to the effect of "repair or replace as necessary" is warranted for the warranty period.

Any warranted part which is scheduled for replacement as required maintenance is warranted for the period of time prior to the first scheduled replacement point for that part.

The owner will not be charged for diagnostic labor which leads to the determination that a warranted part is defective, if the diagnostic work is performed at a warranty station.

The manufacturer is liable for damages to other engine components caused by the failure under warranty of any warranted part.

Cummins is not responsible for failures resulting from improper repair or the use of parts which are not genuine Cummins or Cummins approved parts.

These warranties, together with the express commercial warranties and emission warranty are the sole warranties of Cummins. There are no other warranties, express or implied, or of merchantability or fitness for a particular purpose.

About the Manual	i-2	Fuel Warmers.....	M-2
General Information.....	i-2	Gauges.....	M-3
Accelerator Options	FB-3	Governors.....	M-3
Disadvantages.....	FB-3	Heat Sleeves.....	M-3
Driver Activation/Deactivation.....	FB-3	Hydraulic and Power Steering Pumps.....	M-3
Feature Description.....	FB-3	In-Line Connectors.....	M-3
Interaction with other Features and Parameters.....	FB-3	Oil Heaters.....	M-3
Visual Aids.....	FB-3	Prelubrication Systems.....	M-3
Acronyms and Abbreviations	i-13	Radiators.....	M-3
General Information.....	i-13	Throttle Assemblies.....	M-3
Additional Service Literature	L-1	Torque Converters.....	M-3
General Information.....	L-1	Coolant Contamination.....	TS-11
Air Cleaner Restriction	4-1	Coolant Level	4-4
Maintenance Check.....	4-1	Maintenance Check.....	4-4
Air Compressor	4-2	Coolant Loss - External.....	TS-12
Maintenance Check.....	4-2	Coolant Recommendations and Specifications	V-13
Air Compressor Air Pressure Rises Slowly.....	TS-3	Cooling System Sealing Additives.....	V-14
Air Compressor Discharge Lines	7-1	Cooling System Soluble Oils.....	V-15
General Information.....	7-1	Fully Formulated Coolant/Antifreeze.....	V-13
Maintenance Check.....	7-1	Coolant Temperature Above Normal - Gradual Overheat.....	TS-13
Air Intake Piping	4-3	Coolant Temperature Above Normal - Sudden Overheat.....	TS-15
Maintenance Check.....	4-3	Coolant Thermostat	A-10
Air Intake System	V-5	Clean and Inspect for Reuse.....	A-12
Specifications.....	V-5	Finishing Steps.....	A-14
Air Tanks and Reservoirs	3-2	General Information.....	A-10
Drain.....	3-2	Install.....	A-14
Alternate Droop	FB-4	Preparatory Steps.....	A-11
Disadvantages.....	FB-5	Remove.....	A-12
Driver Activation/Deactivation.....	FB-5	Fan, Cooling	4-3
Feature Description.....	FB-4	Inspect for Reuse.....	4-3
Interaction with other Features and Parameters.....	FB-5	Cooling Fan Belt Tensioner	6-1
Visual Aids.....	FB-5	Maintenance Check.....	6-1
Alternator	A-1	Cooling Fan Belt Tensioner	A-15
Finishing Steps.....	A-6	Maintenance Check.....	A-15
General Information.....	A-1	Cooling System	5-1
Initial Check.....	A-1	Drain.....	5-2
Install.....	A-5	Fill.....	5-5
Preparatory Steps.....	A-3	Flush.....	5-3
Remove.....	A-4	General Information.....	5-1
Test.....	A-2	Maintenance Check.....	5-2
Automatic Boost Power	FB-7	Cooling System	7-2
Disadvantages.....	FB-7	Drain.....	7-3
Driver Activation/Deactivation.....	FB-7	Fill.....	7-6
Feature Description.....	FB-7	Flush.....	7-4
Interaction with other Features and Parameters.....	FB-7	General Information.....	7-2
Visual Aids.....	FB-7	Cooling System	V-4
California Emission Control System Warranty, Off-Highway	W-6	Specifications.....	V-4
Capscrew Markings and Torque Values	V-18	Crankcase Breather Tube	3-2
Capscrew Markings and Torque Values - Metric.....	V-18	Maintenance Check.....	3-2
Capscrew Markings and Torque Values - U.S. Customary.....	V-18	Cummins Customized Parts Catalog	L-3
General Information.....	V-18	General Information.....	L-3
Charge-Air Cooler	4-2	Ordering the Customized Parts Catalog.....	L-3
Maintenance Check.....	4-2	Ordering by Telephone.....	L-3
Charge-Air Cooler	A-6	Ordering On-Line.....	L-3
Clean.....	A-6	Cummins/Fleetguard® Filter Specifications	V-8
Inspect for Reuse.....	A-7	General Information.....	V-8
Leak Test.....	A-7	Daily Maintenance Procedures - Overview	3-1
Pressure Differential Test.....	A-9	Engine Operation Report.....	3-1
Temperature Differential Test.....	A-8	General Information.....	3-1
Charge-Air Piping	4-2	Unusual Engine Noise.....	3-1
Maintenance Check.....	4-2	Distributors - International	S-31
Cold Weather Starting	1-4	Locations.....	S-31
General Information.....	1-4	Distributors and Branches	S-4
Using Starting Aids.....	1-5	Australia.....	S-22
Component Manufacturers' Addresses	M-1	Canada.....	S-19
Air Compressors.....	M-1	New Zealand.....	S-26
Air Cylinders.....	M-1	United States.....	S-4
Air Heaters.....	M-1	Division and Regional Offices	S-2
Air Starting Motors.....	M-1	Locations.....	S-2
Alternators.....	M-1	Drive Belt Tension	V-16
Auxiliary Brakes.....	M-1	Tension Chart.....	V-16
Belts.....	M-1	Drive Belt, Cooling Fan	A-16
Catalytic Converters.....	M-1	Inspect for Reuse.....	A-16
Coolant Level Switches.....	M-1	Install.....	A-17
Clutches.....	M-1	Remove.....	A-16
Coolant Heaters.....	M-2	Drive Belts	3-3
Drive Plates.....	M-2	Maintenance Check.....	3-3
Electric Starting Motors.....	M-2	Poly-Vee Belt.....	3-3
Electronic Switches.....	M-2	Cogged Belt.....	3-4
Engine Protection Controls.....	M-2	Electrical System	V-7
Fan Clutches.....	M-2	Batteries (Specific Gravity).....	V-7
Fans.....	M-2	Specifications.....	V-7
Fault Lamps.....	M-2	Electromagnetic Interference (EMI)	1-8
Filters.....	M-2	General Information.....	1-8
Flexplates.....	M-2	System EMI Radiation Levels.....	1-8
Fuel Coolers.....	M-2	System EMI Susceptibility.....	1-8
Fuel Pumps.....	M-2	Emergency and Technical Service	S-1

Index
Page X-2

General Information.....	S-1	General Information.....	i-8
Engine Acceleration or Response Poor.....	TS-18	Welding on a Vehicle with an Electronic Controlled Fuel System.....	i-8
Engine Diagrams	E-4	General Safety Instructions	i-6
Engine Views.....	E-4	Important Safety Notice.....	i-6
Engine Difficult to Start or Will Not Start (Exhaust Smoke).....	TS-20	General Engine	V-1
Engine Difficult to Start or Will Not Start (No Exhaust Smoke).....	TS-22	Specifications.....	V-1
Engine Identification	E-1	Hot Shutdown Monitor	FB-6
Air Compressor.....	E-3	Disadvantages.....	FB-7
Cummins® Engine Nomenclature.....	E-2	Driver Activation/Deactivation.....	FB-7
ECM Dataplate.....	E-3	Feature Description.....	FB-6
Engine Dataplate.....	E-1	Interaction with other Features and Parameters.....	FB-7
Fuel Injection Pump Dataplate.....	E-2	Visual Aids.....	FB-7
Engine Noise Excessive — Combustion Knocks.....	TS-26	How to Use the Manual	i-3
Engine Operating Range	1-8	General Information.....	i-3
General Information.....	1-8	Idle Shutdown	FB-2
Engine Power Output Low.....	TS-27	Disadvantages.....	FB-2
Engine Runs Rough at Idle.....	TS-29	Driver Activation/Deactivation.....	FB-2
Engine Runs Rough or Misfires.....	TS-30	Feature Description.....	FB-2
Engine Shutdown	1-8	Interaction with other Features and Parameters.....	FB-2
General Information.....	1-8	Visual Aids.....	FB-2
Engine Shuts Off Unexpectedly or Dies During Deceleration.....	TS-32	Illustrations	i-5
Engine Speed Surges at Low or High Idle.....	TS-33	General Information.....	i-5
Engine Speed Surges in PTO or Cruise Control.....	TS-36	Intermediate Speed Control (ISC)	FB-3
Engine Speed Surges Under Load or in Operating Range.....	TS-34	Disadvantages.....	FB-4
Engine Starts But Will Not Keep Running.....	TS-37	Driver Activation/Deactivation.....	FB-4
Engine Will Not Crank or Cranks Slowly (Air Starter).....	TS-39	Feature Description.....	FB-3
Engine Will Not Crank or Cranks Slowly (Electric Starter).....	TS-41	Interaction with other Features and Parameters.....	FB-4
Engine Will Not Reach Rated Speed (RPM).....	TS-42	Visual Aids.....	FB-4
Exhaust System	V-6	Lubricating Oil and Filters	5-7
Specifications.....	V-6	Drain.....	5-7
Fan Control	FB-1	Fill.....	5-9
Disadvantages.....	FB-1	Install.....	5-8
Driver Activation/Deactivation.....	FB-1	Remove.....	5-8
Feature Description.....	FB-1	Lubricating Oil Consumption Excessive.....	TS-53
Interaction with other Features and Parameters.....	FB-1	Lubricating Oil Contaminated.....	TS-54
Visual Aids.....	FB-1	Lubricating Oil Level	3-3
Fan Hub, Belt Driven	6-2	Maintenance Check.....	3-3
Maintenance Check.....	6-2	Lubricating Oil Loss.....	TS-55
Fan Spacer and Pulley	A-17	Lubricating Oil Pressure High.....	TS-57
Inspect for Reuse.....	A-17	Lubricating Oil Pressure Low.....	TS-58
Install.....	A-18	Lubricating Oil Recommendations and Specifications	V-10
Preparatory Steps.....	A-17	General Information.....	V-10
Remove.....	A-17	New Engine Break-in Oils.....	V-12
Flow Diagram, Air Intake System	D-10	Lubricating Oil Sludge in the Crankcase Excessive.....	TS-60
Flow Diagram.....	D-10	Lubricating Oil System	V-3
Flow Diagram, Compressed Air System	D-14	Specifications.....	V-3
Flow Diagram.....	D-14	Maintenance Guidelines - Overview	2-1
Flow Diagram, Cooling System	D-9	General Information.....	2-1
Flow Diagram.....	D-9	Maintenance Procedures - Overview	4-1
Flow Diagram, Exhaust System	D-11	General Information.....	4-1
Flow Diagram.....	D-11	Maintenance Procedures - Overview	5-1
Without EGR.....	D-11	General Information.....	5-1
With EGR.....	D-12	Maintenance Procedures - Overview	6-1
Marine Applications.....	D-13	General Information.....	6-1
Flow Diagram, Fuel System	D-2	Maintenance Procedures - Overview	7-1
Flow Diagram.....	D-2	General Information.....	7-1
With Electric Lift Pump.....	D-3	Maintenance Procedures - Overview	8-1
Flow Diagram, Lubricating Oil System	D-4	General Information.....	8-1
Flow Diagram.....	D-4	Maintenance Record Form	2-4
Fuel Consumption Excessive.....	TS-46	Maintenance Data.....	2-4
Fuel Consumption Rate Logger	FB-8	Maintenance Schedule	2-3
Disadvantages.....	FB-8	General Information.....	2-3
Driver Activation/Deactivation.....	FB-8	Oil Drain Intervals.....	2-3
Feature Description.....	FB-8	Multiple Unit Synchronization	FB-5
Interaction with other Features and Parameters.....	FB-8	Disadvantages.....	FB-6
Visual Aids.....	FB-8	Driver Activation/Deactivation.....	FB-6
Fuel Filter (Spin-On Type)	5-6	Feature Description.....	FB-5
Install.....	5-6	Interaction with other Features and Parameters.....	FB-6
Prime.....	5-7	Visual Aids.....	FB-6
Remove.....	5-6	Normal Starting Procedure	1-2
Fuel in the Lubricating Oil.....	TS-49	General Information.....	1-2
Fuel Recommendations and Specifications	V-9	Jump Starting.....	1-4
Fuel Recommendations.....	V-9	All Engines International/Industrial (Off-Highway)	W-4
Fuel System	V-2	All Engines United States and Canada Industrial (Off-Highway)	W-1
Preparatory Steps.....	V-2	Operating Instructions - Overview	1-1
Fuel-Water Separator	3-2	General Information.....	1-1
Drain.....	3-2	Operating the Engine	1-5
Canister Type.....	3-2	Ambient Temperature.....	1-6
Spin-on Type.....	3-3	0 to -32°C [32 to -25°F].....	1-6
General Cleaning Instructions	i-9	-32 to -54°C [-25 to -65°F].....	1-6
Abrasive Pads and Abrasive Paper.....	i-9	Cold Weather.....	1-6
Definition of Clean.....	i-9	Normal.....	1-5
Gasket Surfaces.....	i-10	Winterfronts and Shutters.....	1-7
Plastic Bead Cleaning.....	i-11	Overhead Set	8-1
Solvent and Acid Cleaning.....	i-10	Adjust.....	8-3
Steam Cleaning.....	i-11	Finishing Steps.....	8-7
General Repair Instructions	i-8	Install.....	8-5

Preparatory Steps.....	8-1
Remove.....	8-1
Problem Solving	S-1
General Information.....	S-1
Radiator Hoses	4-3
Maintenance Check.....	4-3
Regional Offices - International	S-27
Locations.....	S-27
Routine Service and Parts	S-1
General Information.....	S-1
Sealants	V-17
General Information.....	V-17
Service Literature Ordering Location	L-2
Contact Information.....	L-2
Starting Motor	A-18
Clean and Inspect for Reuse.....	A-20
Install.....	A-21
Cummins Branded Starters.....	A-22
Non-Cummins Branded Starters.....	A-22
Measure.....	A-21
Remove.....	A-19
Rotation Check.....	A-18
Starting Procedure After Extended Shutdown or Oil Change	1-5
General Information.....	1-5
Switchable (Alternate) Torque	FB-5
Disadvantages.....	FB-5
Driver Activation/Deactivation.....	FB-5
Feature Description.....	FB-5
Interaction with other Features and Parameters.....	FB-5
Visual Aids.....	FB-5
Symbols	I-4
General Information.....	I-4
System Diagrams - Overview	D-1
General Information.....	D-1
To the Owner and Operator	I-1
General Information.....	I-1
Tool Requirements	2-2
General Information.....	2-2
Troubleshooting Procedures and Techniques	TS-1
General Information.....	TS-1
Troubleshooting Symptoms Charts	TS-2
General Information.....	TS-2
Turbocharger Leaks Engine Oil or Fuel.....	TS-64
Vibration Damper, Rubber	7-7
Inspect.....	7-7
Vibration Damper, Viscous	7-7
Inspect.....	7-7
Water-in-Fuel Sensor	FB-1
Disadvantages.....	FB-2
Driver Activation/Deactivation.....	FB-2
Feature Description.....	FB-1
Interaction with other Features and Parameters.....	FB-2
Visual Aids.....	FB-2

