

FOREWORD

This shop manual contains the specifications, construction, operation, adjustment and service procedures of the Model D6A diesel engine for service mechanics engaged in servicing of the Hyundai diesel engines.

Please make the most of this shop manual to perform correct servicing and wasteless operations.

Note that some of the contents of this shop manual are subject to change owing to improvements, etc. that may be introduced after publication of the shop manual.

HYUNDAI MOTOR COMPANY
COMMERCIAL ENGINE DEPT

Printed in Korea

HYUNDAI MOTOR COMPANY

COMPILATION OF THIS MANUAL

1. The contents of this shop manual are divided as shown below when edited.

Group No	Group Name	Contents
1	General	General description, outside view photograph and cross section view of engine, specifications, construction and operations
2	Service standards	Engine service standards, service standards table, tightening torque table, sealant and grease table
3	Special tools	Shapes and usages of special tools
4	Determining time to overhaul	Decision on time to overhaul, measurement of compression pressure, troubleshooting
5	Engine adjustment and break-in operation	Inspection and adjustment of valve clearance, inspection and adjustment of fuel injection start timing, engine speed adjustment
6	Removal and installation of auxiliaries	Removal and installation of auxiliaries such as injection pump, starter, alternator, injection pump drive
7	Engine proper	Disassembly, inspection and reassembly of engine proper, including cylinder head, valve mechanism, camshaft, piston, crankshaft, timing gear, flywheel, etc.
8	Inlet and exhaust	Disassembly, inspection and reassembly of air cleaner, turbo-charger, etc.
9	Lubrication	Disassembly inspection and reassembly of lubrication system, including oil pump, oil filter, oil cooler, etc.
10	Cooling	Disassembly, inspection and reassembly of cooling system, including water pump, thermostat, etc.
11	Fuel	Disassembly, inspection and reassembly of fuel system, including injection pump, injection nozzle, fuel filter, etc.
12	Electrical	Inspection of starter, starter relay, alternator, etc.
13	Other equipment	Disassembly, inspection and reassembly of infection pump drive.

2. How to read disassembly and reassembly drawings

- (a) The part names and numbers in the drawings correspond to those in the text. The parts are numbered in the order of disassembly.
- (b) The inspection items to be performed during disassembly operations are shown in the disassembly drawings.
- (c) All tightening torque specifications in the reassembly drawings may be considered "dry" unless "wet" is specified.

3. Definition of terms

(a) Nominal Value(Abbr. : NV)

Shows dimension of single part, mutual clearance between parts or standard performance. Values, however, are rounded off within limits necessary for inspection.

(b) Repair Limit(Abbr. : RL)

Shows that when specified value is reached, repair is necessary, Repair means adjustment, grinding, replacement of bushings, metals and the like, selection of oversize, selection of shim thickness, etc.

(c) Service Limit(Abbr. : SL)

Shows that when specified value is reached, replacement of the parts with new one is necessary.

(d) Basic Diameter(Abbr : BD)

Shows nominal diameter of part to be measured.

4. Unit

The SI unit(International System of Units) is used. Metric notation is jointly shown in parentheses.

5. Table of Conversion Rate for Foot–pound Units into SI Units

Unit	Sign of SI unit	Sign of foot–pound unit	Conversion rate
Mass quantity of matter	kg	lb	1kg=2.2046 lb
	g	oz	1g=0.035274 oz
Dimension	m	ft.	1m=3.2808 ft.
	mm	in.	1mm=0.03937 in.
Capacity	lit.	gal.	1 lit.=0.2642 gal.(U.S.) 0.220 gal.(Imp.)
	cc	oz	1 cc=0.033814 oz(U.S.) 0.035195 oz(Imp.)
Force	N(Newton)	lbf	1 N=0.2248 lbf
Pressure	kpa(Kilopascal)	lbf/in. ²	1 kpa=0.145 lbf/in. ²
			1 kpa=0.2953 in. Hg
Stress	N/cm ²	lbf/in. ²	1 N/cm ² =1.45 lbf/in. ²
Moment of force	N/m	ft.lbf	1 N/m=0.7375 ft.lbf
Output	kw(kilowatt)	HP	1 kw=1.34 HP
Temperature	°C	°F	t °C=(1.8t °C + 32)°F

1-1 GENERAL DESCRIPTION

1-1-1 Engine Section Views

(1) D6AU

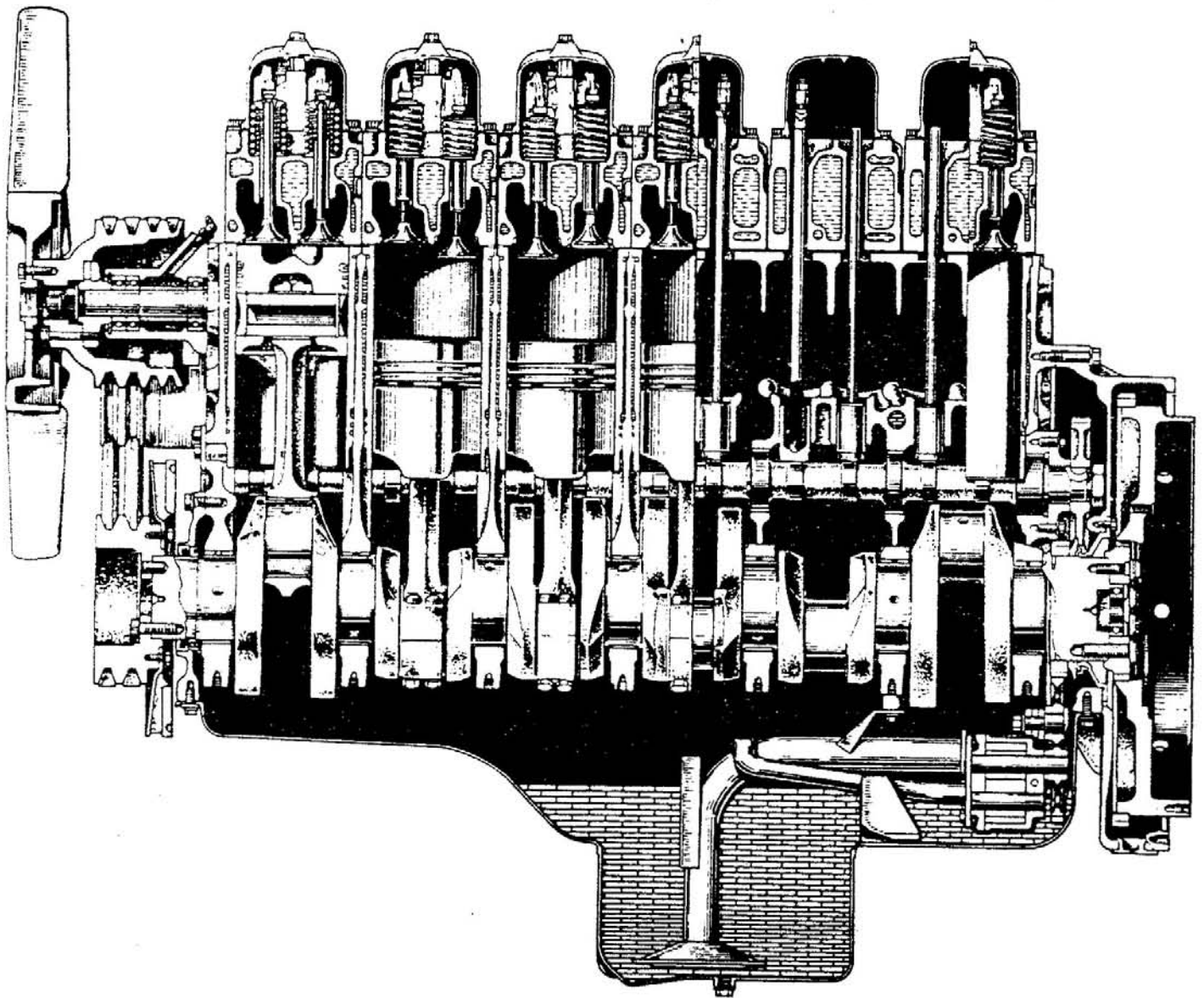

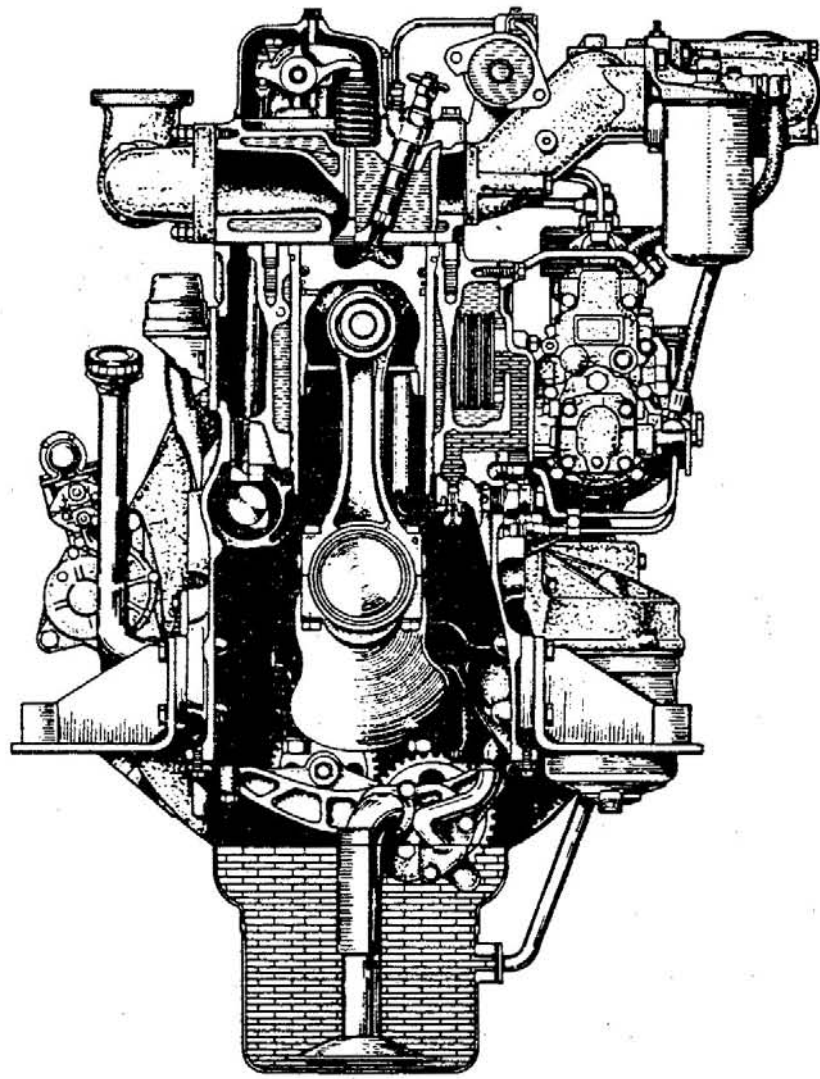

(2) D6AZ

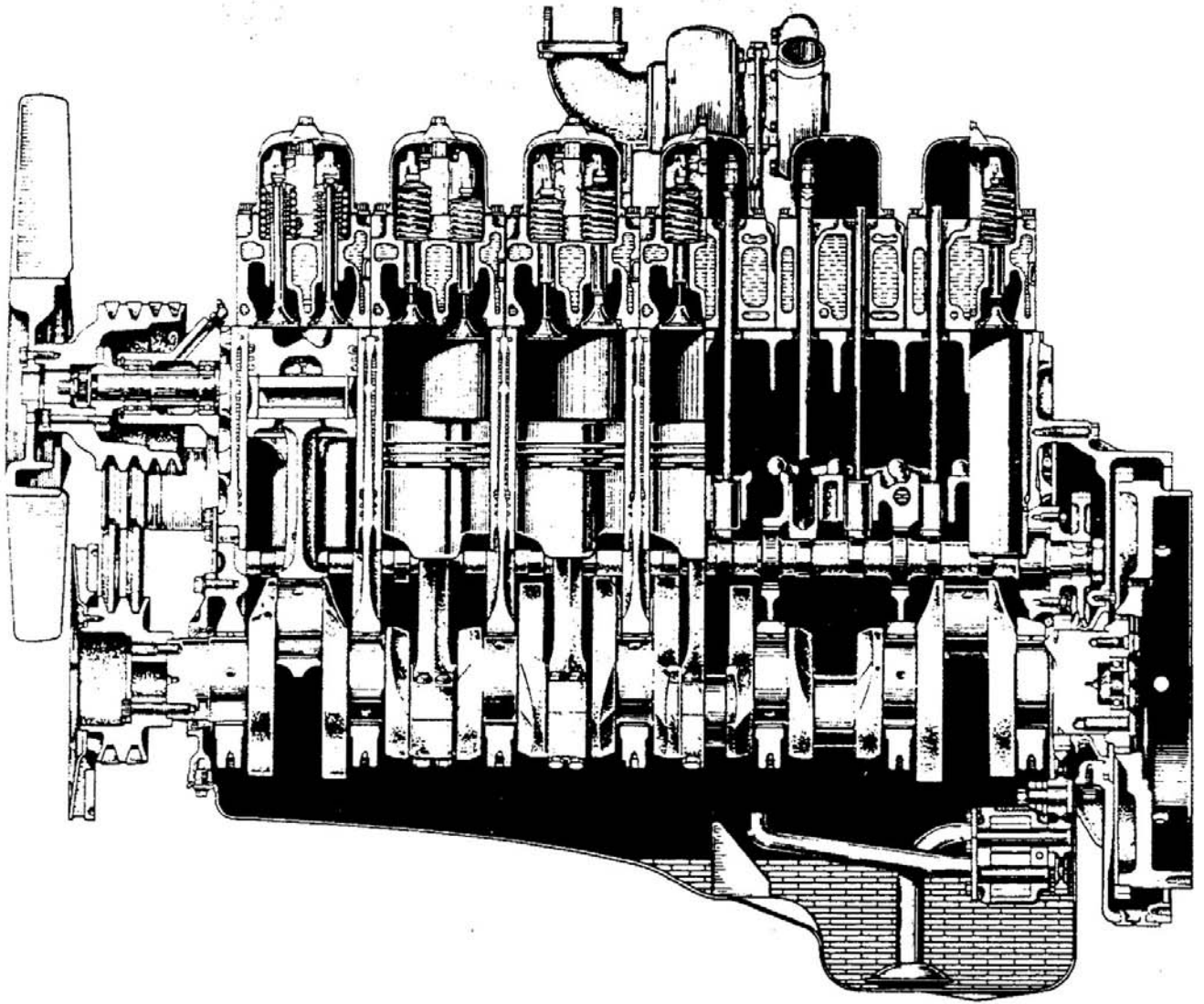

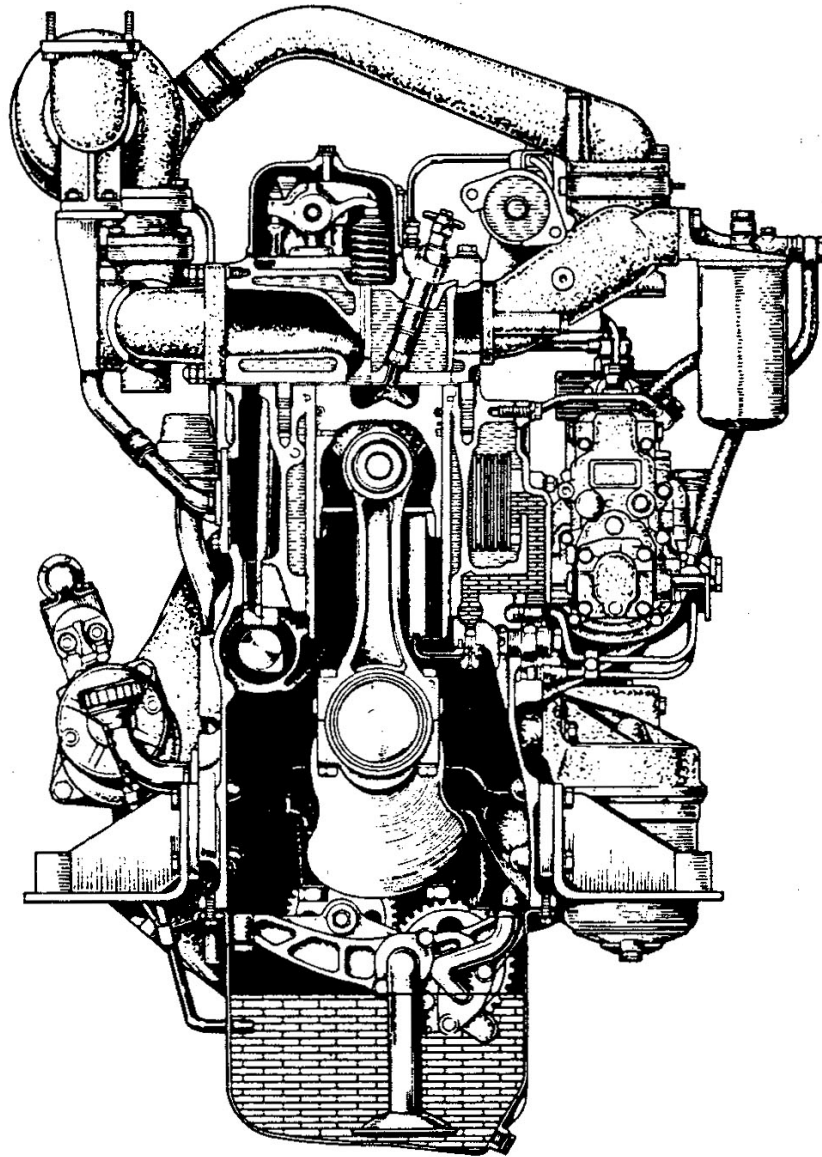

1-1-3 Engine Number, Nameplate

(1) Engine Number

The engine number is stamped on the left side of the crankcase, near the front portion, as shown.

Ex : Model Production year Engine No.
 ↓ ↓ ↓
 D6AU W 123456

The engine number is important in knowing the history of the engine.

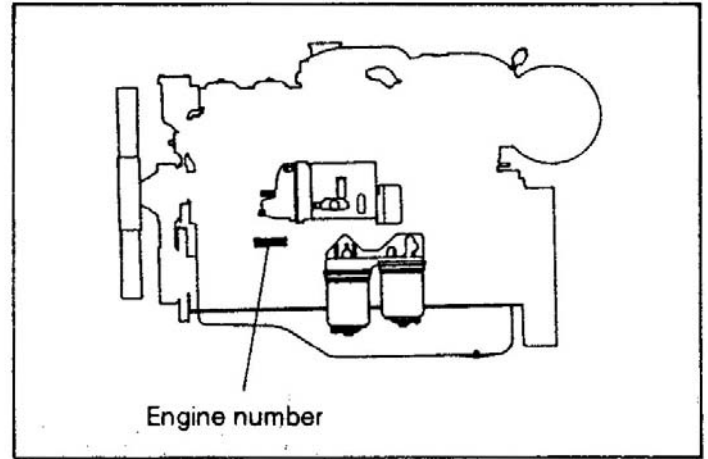

(2) Name plate

The nameplate is bonded to the side cover on the right side of the engine and shows the following.

- Engine Model
- Total Displacement
- Output
- Valve Clearance
- Firing Order
- Fuel Injection Timing

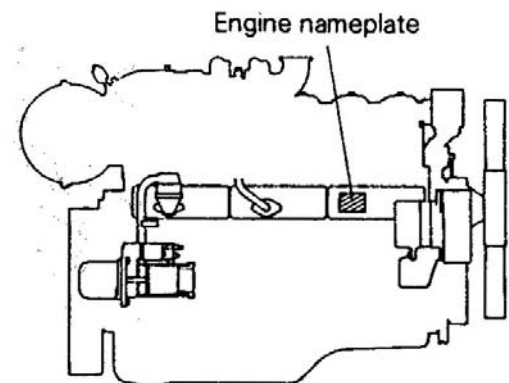
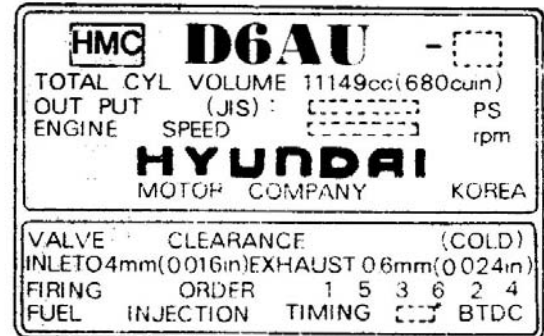

1-2 SPECIFICATIONS

1-2-1 Principal Specifications

Item	Specification		
	D6AU	D6AZ	D6AC
Engine model	D6AU	D6AZ	D6AC
Type	Water cooled, 4-cycle diesel	Water cooled, 4-cycle diesel	←
Number of cylinders-arrangement	6-in-line	6-in-line	←
Valve mechanism	Overhead Valve	Overhead Valve	←
Combustion chamber	Direct injection type.	Direct injection type.	←
Cylinder bore × stroke	mm 130 × 140	130 × 140	←
Total displacement	cc 11149	11149	←
Compression ratio	17	16	16.5
Firing order	1-5-3-6-2-4	1-5-3-6-2-4	←
Engine dimensions			
Overall length	1612	1607	1289.6
Overall width	mm 924	907	847.5
Overall height	mm 1248	1392	1018
Weight	kg 930	970	970

1-2-2 Specifications of Each Device

Engine proper

Item		Specifications
Cylinder liner	Type	Wet type
Piston	Type	Trunk-shaped, slipper skirt type
Piston rings	Q'ty	Two compression rings One oil ring

Inlet and Exhaust

Item		Specifications
Air cleaner		
Element	Type	Cyclone filter paper type
Turbocharger		D6AZ
	Type	Turbocharger
	Model	Mitsubishi Schwitzer 3LM

Lubrication

Item		Specification			
Engine oil	Quality	[D6AU] API classification "FOR SERVICE CC" or better		[D6AZ(AC)] API classification "FOR SERVICE CD" or better	
		For gen- erators	For con- struction machinery	For gen- erators	For con- struction machinery
Oil pan oil quantity		Approx. 20 lit.	Approx. 23.3 lit.	Approx. 20 lit.	Approx. 23.3 lit.
Oil filter oil quantity		Approx. 3 lit.		Approx. 3 lit.	
Lubricationg system		Oil pump forced feed system Gear Pump forced feed system Ball valve type			
Oil pump	Type				
Relief valve	Type				
Oil filter		Filter paper type			
Full flow filter element type		Filter paper type			
By pass filter element type		Piston valve type with electric contacts			
Oil bypass alarm type		Shell and plate type(multi-plate type)			
Oil cooler	Type	Piston valve type			
Bypass valve	Type	Piston valve type			
Regulator valve	Type	Piston valve type			
Oil jet					
Check valve	Type	Piston valve type			

Cooling

Item	Specification
Cooling system	Water-cooled, forced circulation system
Cooling water quantity (Engine proper)	24 lit.
Water pump	Centrifugal type
Type	V-belt drive
Drive system	
V-belt	(With fan)
Type × quantity	Low edge cog Type B × 1 (for water pump)
	Low edge cog Type C × 2 (for fan drive)
	(Without fan)
	Low edge cog Type C × 1 (for water pump)
Thermostat	Wax pellet type bottom bypass system
Type	
Valve opening temperature × quantity	71°C × 2
Fan	Made of polypropylene, blow-off type
Type	

Fuel

Item	Specification		
	[D6AU]	[D6AZ]	[D6AC]
Injection pump proper			
Type	Boash Type AD	Boash Type P	←
Model	NP-PE6AD 105	NP-PE6P 120	←
Turing direction (as viewed from drive side)	Counter Clockwise	Counter Clockwise	←
Plunger			
Diameter	10.5mm	12mm	←
Governor			
Type	All speed governor	All speed governor	←
Model	RSV	Electric Gov.	←
Feed pump			
Model	NP-FP/KE22ACB	NP-FP/KE-PS	←
Automatic timer			
Type	Mechanical automatic timer	Mechanical automatic timer	←
Model	SA	SP	←
Injection nozzle			
Type	Hole type (1-spring nozzle)	Hole type (2-spring nozzle)	←
No. of orifices	5	5	←
Orifices diameter	0.33mm	0.34mm	←
Orifices angle	154°	150°	←
Injection pressure	220kgf/cm ²	220kgf/cm ²	←
Fuel filter			
type	Cartridge type		

Electrical

Item	Specifications
Voltage-Polarity	24V-(-) ground
Starter	
Type	Solenoid shift Type Reduction starter
Output	24V-5.5kW
Reduction mechanism	Single stage reduction by internal spur gear
Starter relay	
Model	M72S3006
Alternator	
Type	Alternator with built-in IC regulator
Output	24V-40A
Intake air heater	
Type	Electric heating type
Capacity	2.86kW
Heater relay	
Fuse capacity	127A

Automatic stop system (For generators)

Item	Specifications
Stop solenoid	
Type	Solenoid type
Oil pressure switch	
Type	Diaphragm type with built-in electric contacts
Water temp unit	
Type	Wax type with built-in electric contacts

1-3 CONSTRUCTION AND OPERATION

1-3-1 Engine Proper

(1) Combustion Chamber

The combustion chamber is formed by the cylinder head and piston top.

The injection nozzle and nozzle tube are mounted to the cylinder head.

The nozzle tube not only holds the nozzle in position but also cools it. Since the outside of the nozzle tube is exposed to the water jacket, the top end of the tube is sealed with an O-ring and the bottom end staked to prevent water leakage.

Fuel is directly injected into the combustion chamber where combustion takes place.

Water directors which direct the flow of coolant are installed at the bottom of the cylinder head to provide more effective cooling around the combustion chamber.

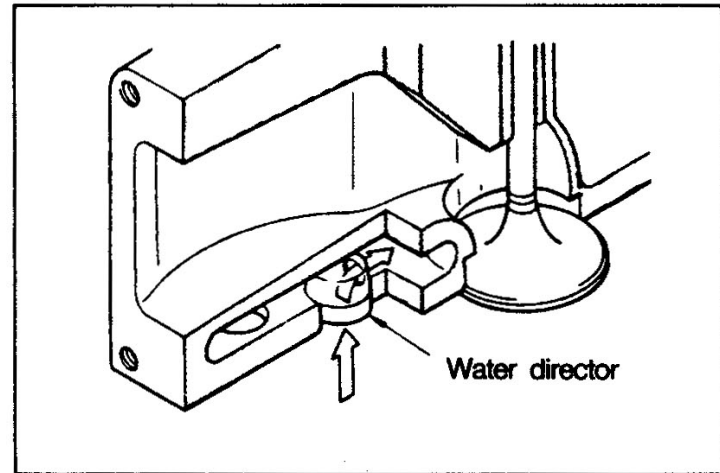
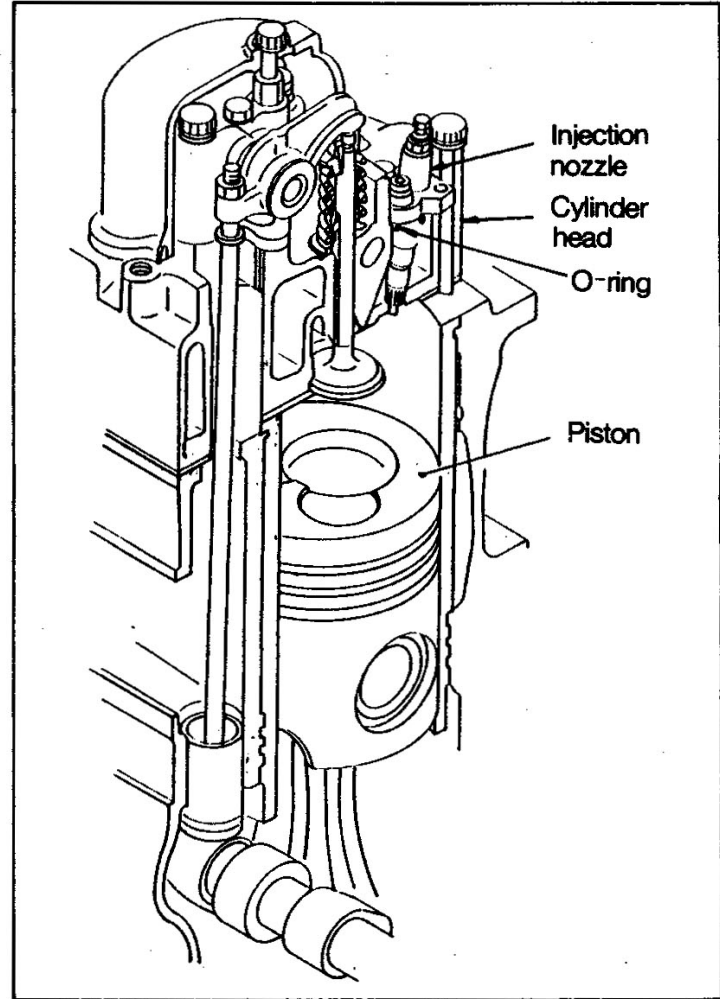

(2) Valve Mechanism

The valve mechanism is an overhead valve (OHV) type and is constructed as shown in illustration at right.

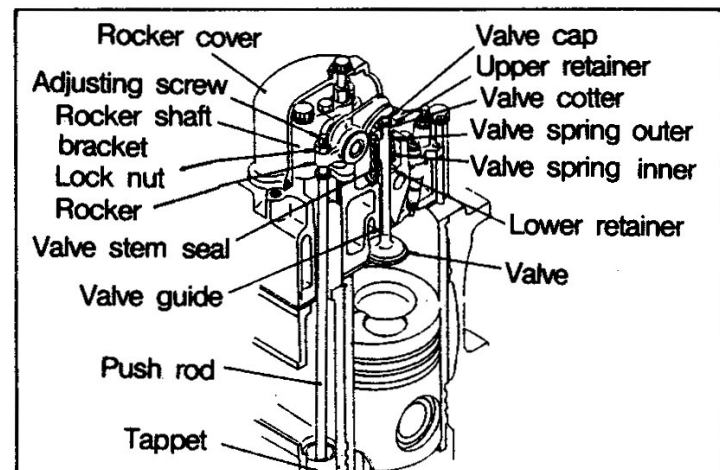

- (a) Both inlet and exhaust valves are made of surface-treated heat-resisting steel. The valve seat angle is 45° .

The valve stem has a valve stem seal which controls the quantity of lubricating oil on the sliding surfaces of valve and valve guide.

- (b) The valve springs are unequally pitched springs. Two springs, inner and outer, different in coiled direction are installed.

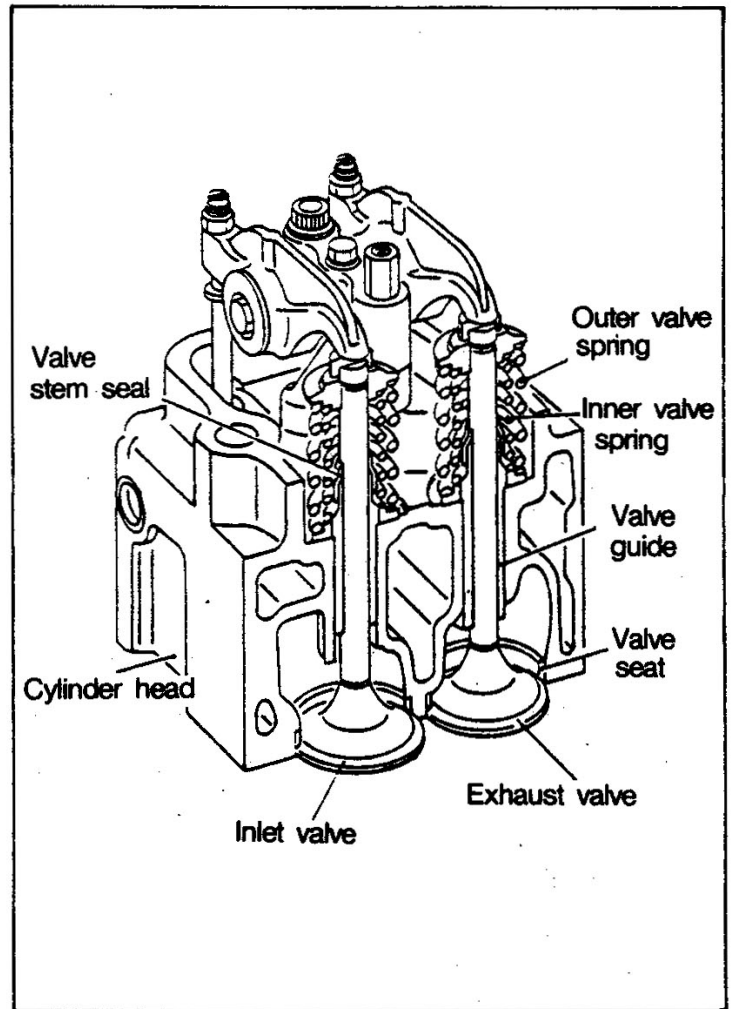

- (c) The rocker and rocker shaft are supported on the rocker shaft bracket and are independently installed for each cylinder. The inlet and exhaust rockers are common parts, and the end sliding portions are quenched. The rocker shaft is a hollow round rod sealed off by thrust plates at both ends. The hollow inside of the shaft constitutes an engine oil passage.

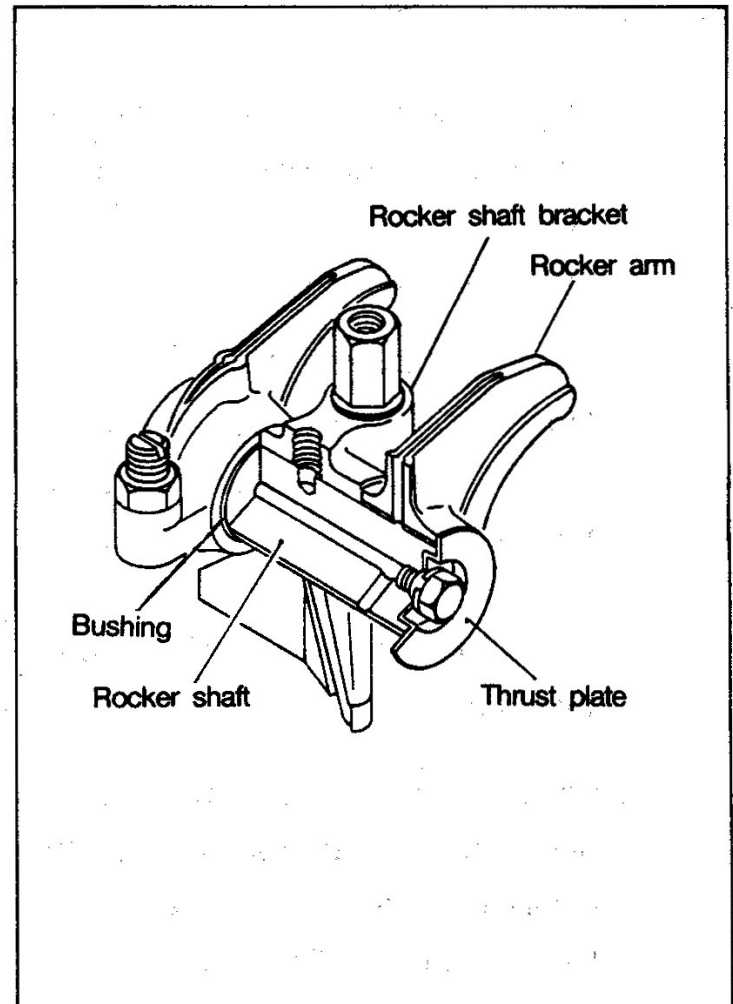

- (d) A steel ball is welded to the bottom end of the push rod and a spherical concave-shaped cup welded to the top end. Both ends are case-hardened.
- (e) The tappet is a cylindrical type, and the portion making contact with the camshaft has a spherical surface. The tappet is removable through the side of the crankcase.
- (f) The cam profile of the camshaft has a special curve. The surface is induction-hardened to improve the performance of the valve mechanism at high speeds and to improve wear resistance.

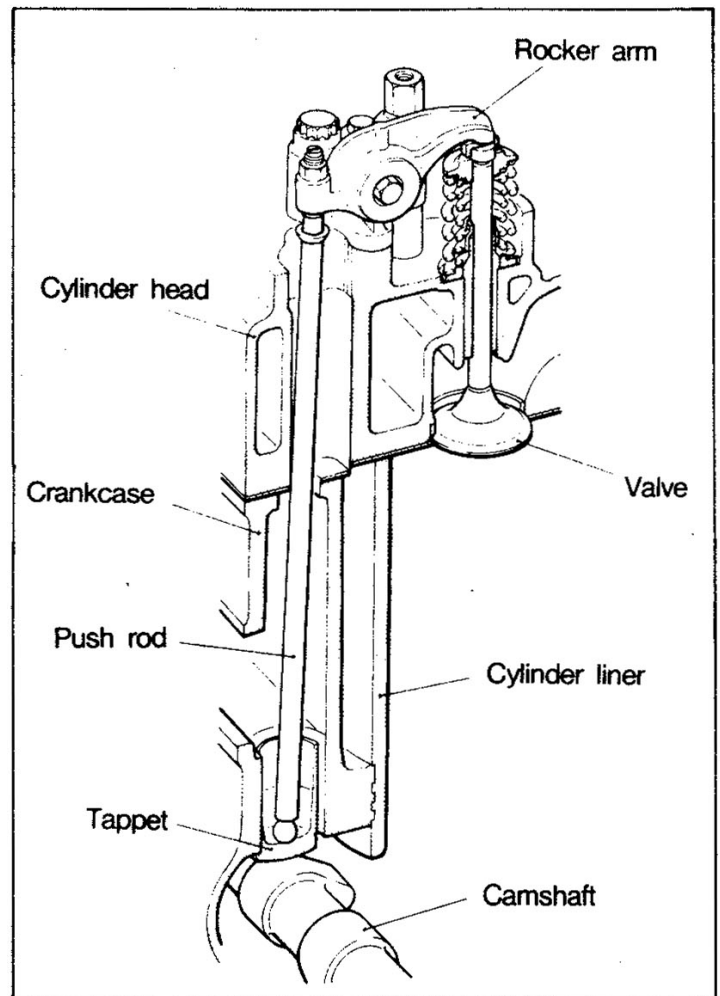

(3) Crankcase and Cylinder Liner

- (a) The crankcase is made of cast iron, has a high rigidity and is so constructed as to minimize stress concentration and deformation.
- (b) Seven camshaft bushings are installed in the camshaft bearing portions of the crankcase. To facilitate insertion and removal of the camshaft from the rear end of the case, the bearing I.D. is made smaller toward the front.
- (c) Coolant is forced in from the water pump at the left front end of the crankcase. after cooling the oil cooler, the coolant flows through the

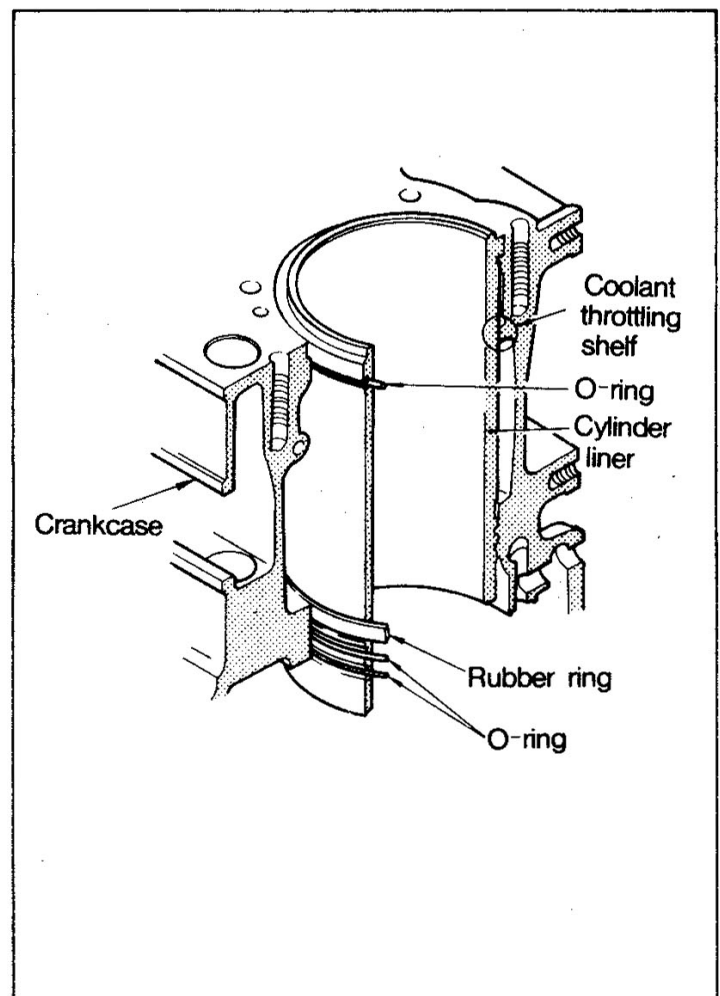

water jacket holes to around all cylinders. After cooling the cylinders, the coolant reaches the cylinder head

(d) The cylinder liner is a removable wet type and is press-fitted in the crankcase at the top of the crankcase and at the bottom of the water jacket.

Rubber rings and O-rings are provided at the top and bottom of the cylinder liner to prevent entry of coolant. The water jacket has a throat for higher cooling performance.

(4) Piston and Piston Ring

(a) Piston

The piston is an aluminum alloy casting. The one for the D6AU has a re-entrant type combustion chamber at the top, whereas the one for the D6AZ has a toroidal type combustion chamber.

A Niresist piston ring insert is cast into the 1st piston ring groove to increase durability.

A size classification mark(oversize dimension on oversize pistons) for selection fit with the cylinder liner, a piston weight and part No., and a front mark "F" and arrow indicating the piston installing direction are stamped on the top surface of the piston.

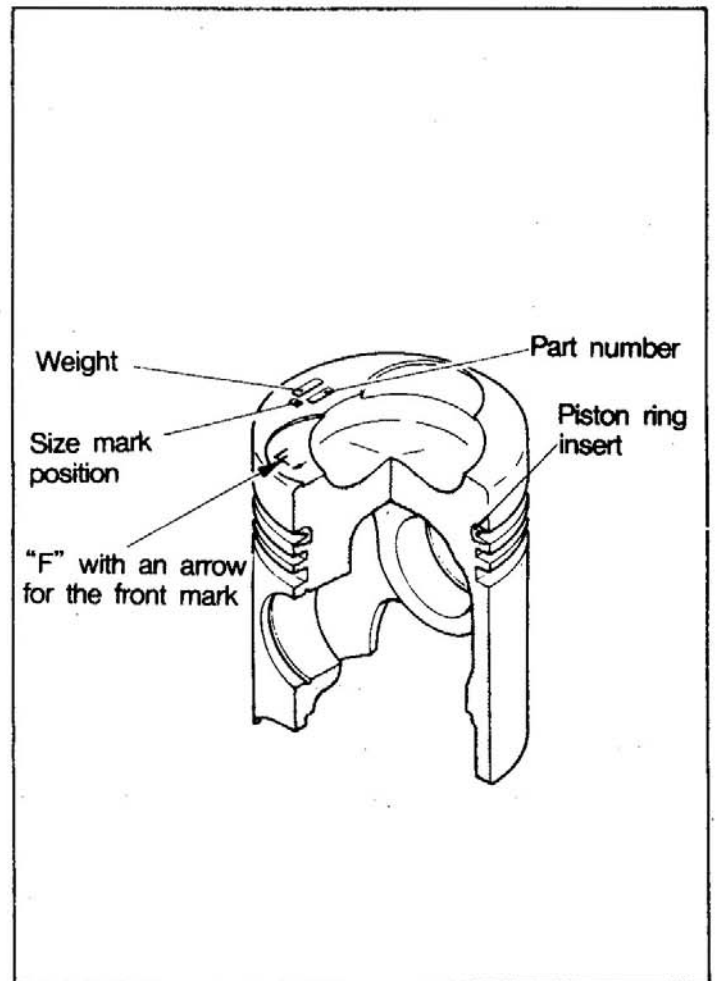

The piston pin is fitted in the piston and connecting rod in fullfloating style with the snap rings fitted at both ends of the piston pin to prevent the pin from slipping off.

(b) Piston ring

The piston rings are three in total ; two compression rings and one oil ring. The sliding surface of each ring is hard chrome plated to improve durability.

The piston rings are shaped as shown. The 1st compression ring is a barrel-faced full keystone type, the 2nd compression ring is a taper faced inner cut type, and the oil ring is a dual type with an expander spring.

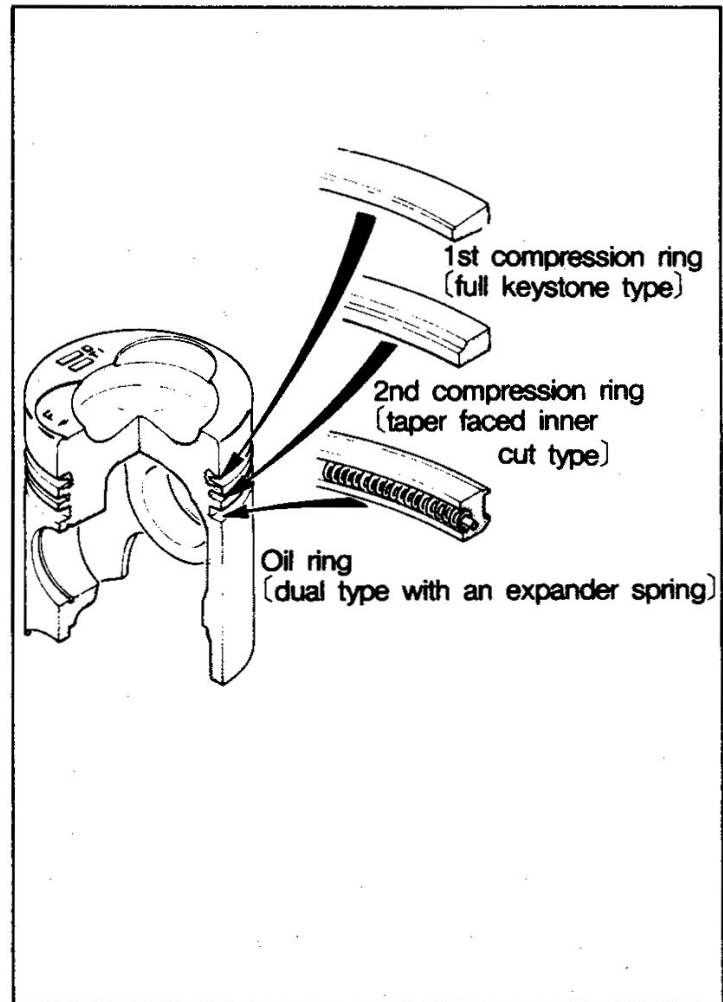

(5) Connecting Rod and Connecting Rod Bearing

The connecting rod is I-section die forging and has a high rigidity. A lead bronze bushing is installed in the small end and a split type plain bearing used in the big end.

An oblique oil passage is provided in the stem portion for lubrication of the small end bushing.

The connecting rod and connecting rod cap are coupled by four bolts.

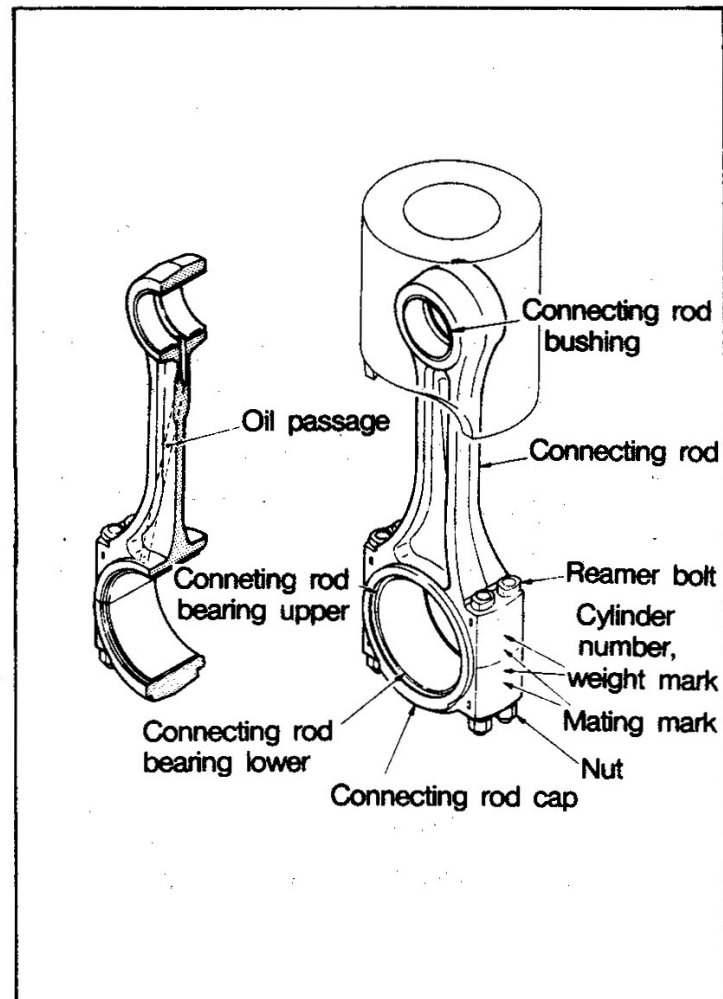

(6) Crankshaft and Main Bearing

- (a) The crankshaft is a high rigidity die forging with integrally forged balance weights.

The pin and journal are induction hardened for higher wear resistance. An oil hole is provided between each journal and pin, allowing some of the main bearing lubricating oil to be fed to the pin to lubricate the connecting rod bearing. At the rear of the crankshaft, the crankshaft gear which drives the timing gear is fitted.

An oil seal is provided at the front of the crankshaft and an axial lip type oil seal provided at the rear.

The front portion of the crankshaft is a flange type to which the crankshaft pulley is mounted with bolts. A torsional damper mounted to the pulley absorbs the torsional vibration of the crankshaft.

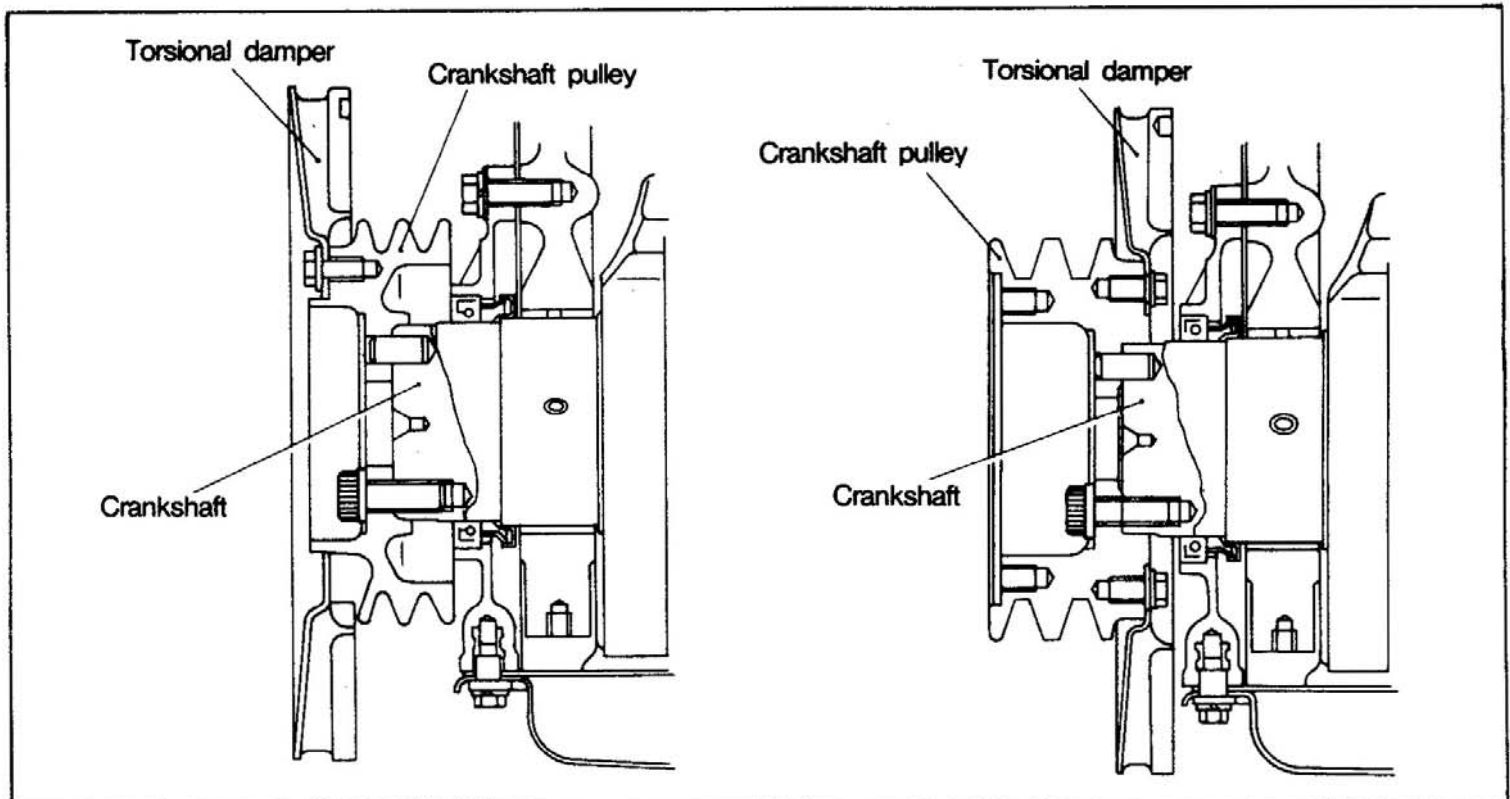
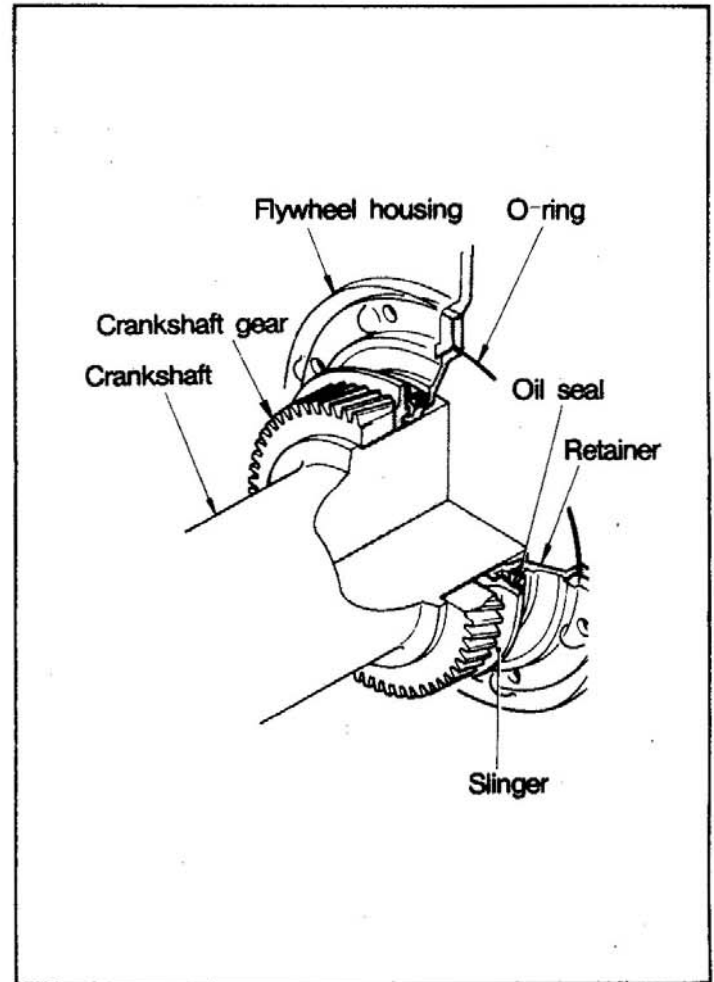

(b) Main bearing

The main bearing is a split type plain bearing consisting of special alloy plating and kelmet metal with backing metal.

The inside surface of upper main bearing has an oil groove and oil hole which is in alignment with the oil hole in the crankshaft.

Seven pairs of main bearings are provided. Halved thrust plates are mounted at the rearmost bearing cap.

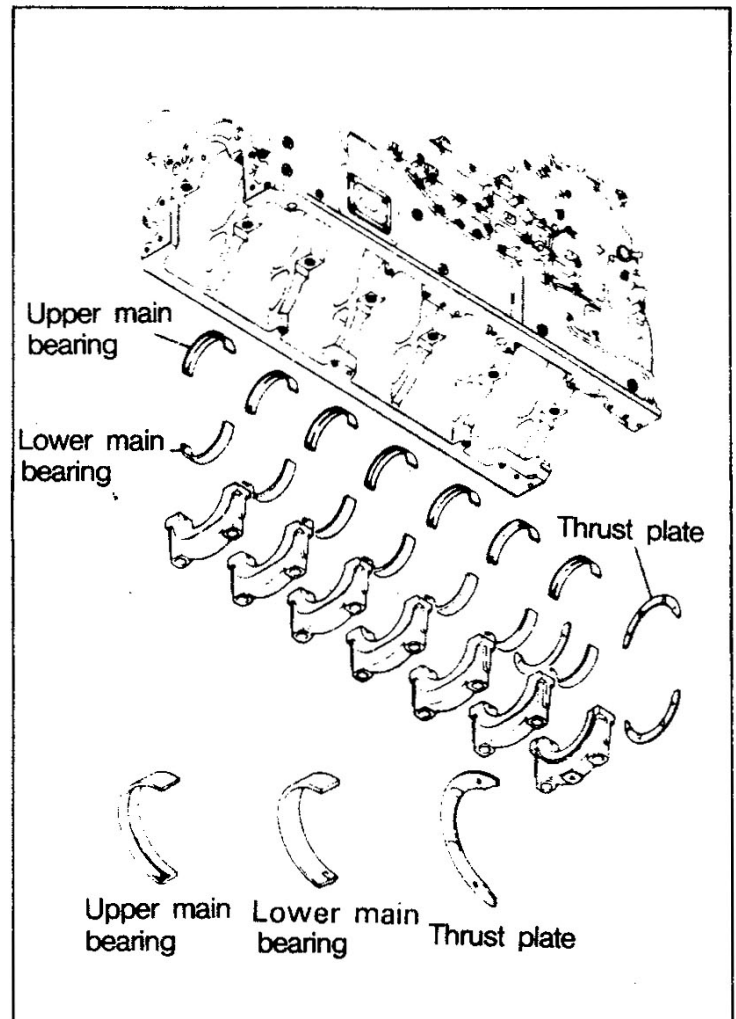

(7) Timing Gear

The timing gears are accommodated in the flywheel housing at the rear of the engine. The gear train is as shown below.

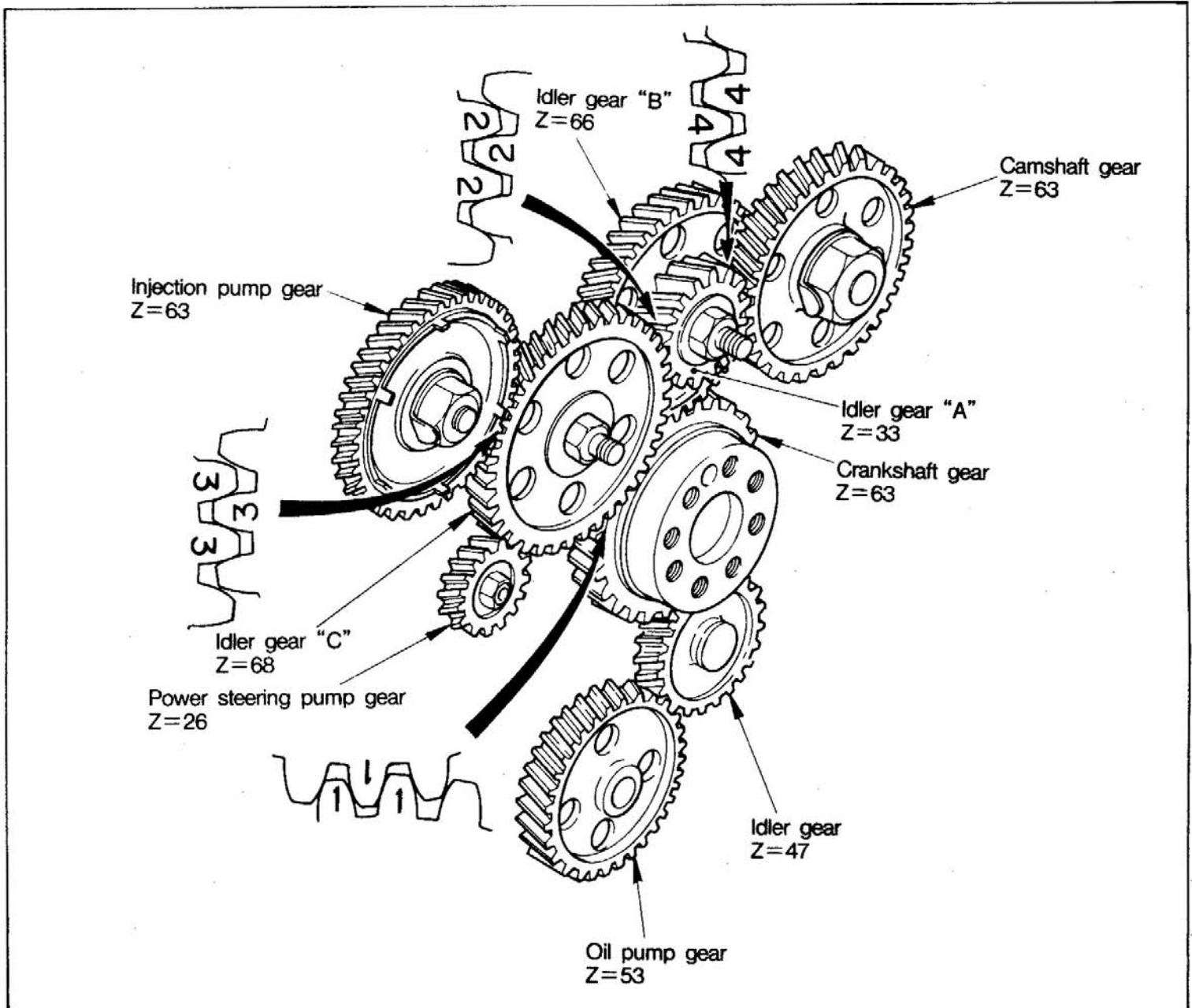

Each gear is a carbon steel helical gear. The tooth surfaces are machined by shaving to form close-tolerance tooth profile, and are given surface treatment to offer improved durability.

A timing mark is stamped on each timing gear. Correct meshing can be achieved by aligning the timing marks at reassembly.

The crankshaft gear, installed on the crankshaft and positioned by a dowel pin drives all the gears.

The idler gear is mounted to the crankcase with the idler shaft bolt and is supported by the flywheel housing at the other end.

A bushing is installed on the inside circumference of the idler gear and turns on the idler shaft.

The bushing is lubricated by the oil which flows through the inside of the idler shaft from the crankcase oil hole.

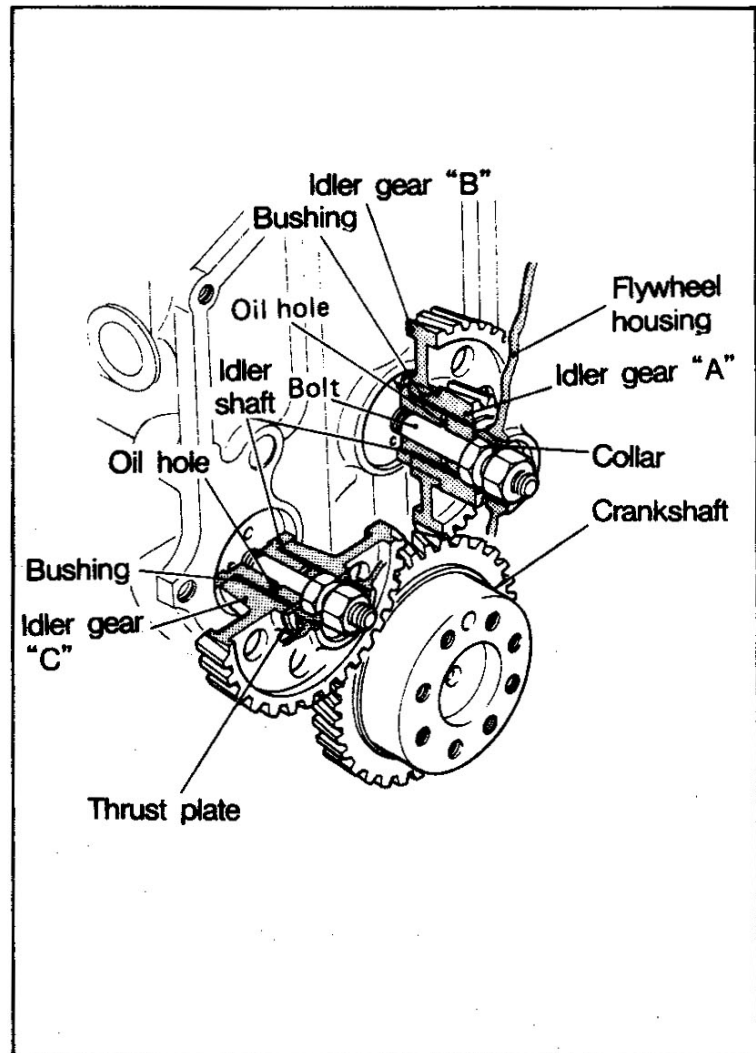

A sensor plate is mounted on the injection pump gear.

The sensor plate is smaller than the injection pump gear to facilitate removal of the air compressor, etc. Therefore, the air compressor, etc. can be easily removed with the gear at any position. When they are reinstalled, however, make sure that the timing marks are in alignment.

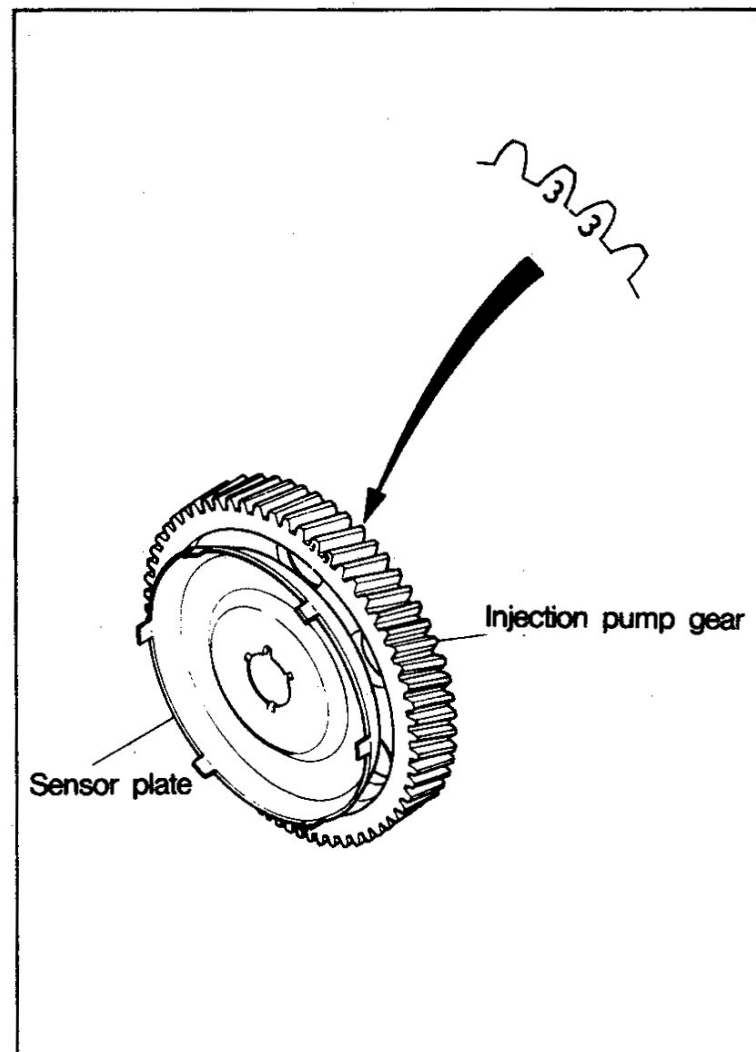

(8) Flywheel

The flywheel is made of cast iron. The pilot bearing of the transmission drive pinion is installed at the center. The ring gear which meshes with the pinion of the starter is shrinkage-fitted on the circumference of the flywheel.

The ring gear teeth are induction-hardened for higher durability and one side of the teeth is chamfered for easier engagement with the pinion of the starter.

The cylinder Nos. and angle scales are stamped on the circumference of the flywheel as shown.

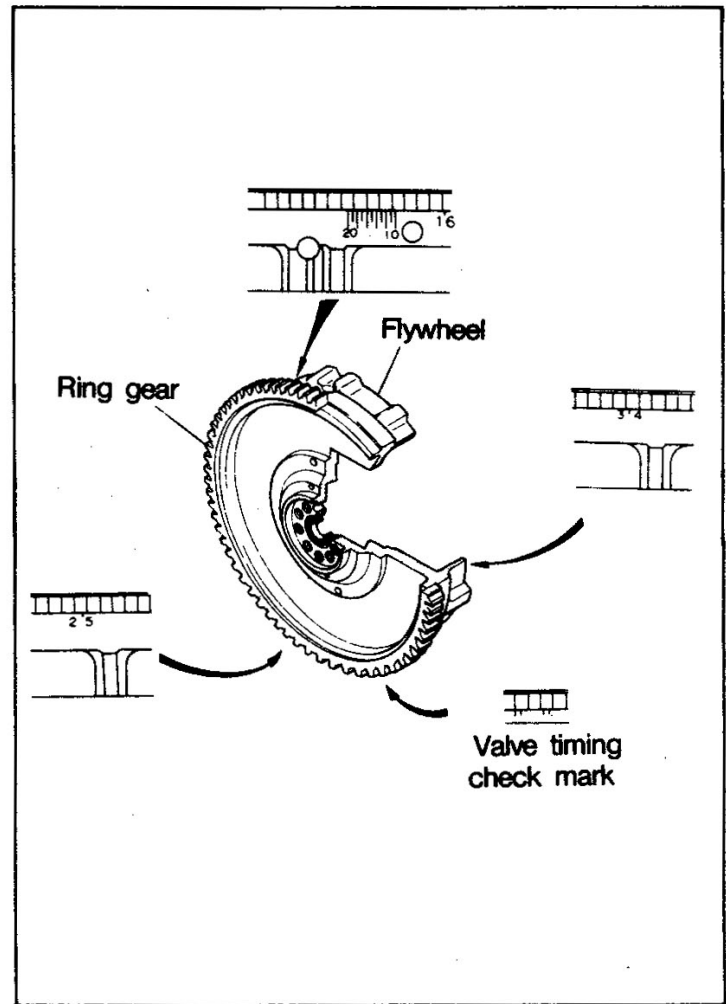

1-3-2- Inlet and Exhaust

(1) Air Cleaner

(a) Cyclone type air cleaner

The element is a plastic-coated and heat-treated filter paper type and is resistant to water and oil. Even if it is contaminated with oil or water, it can be restored to normal by washing.

The air drawn into the element is made to spin at high speed by the vanes on the element, so large particles of dust are centrifugally separated (cyclone function). Small particles of dust are removed by the filter paper element, so clean air is drawn into the engine.

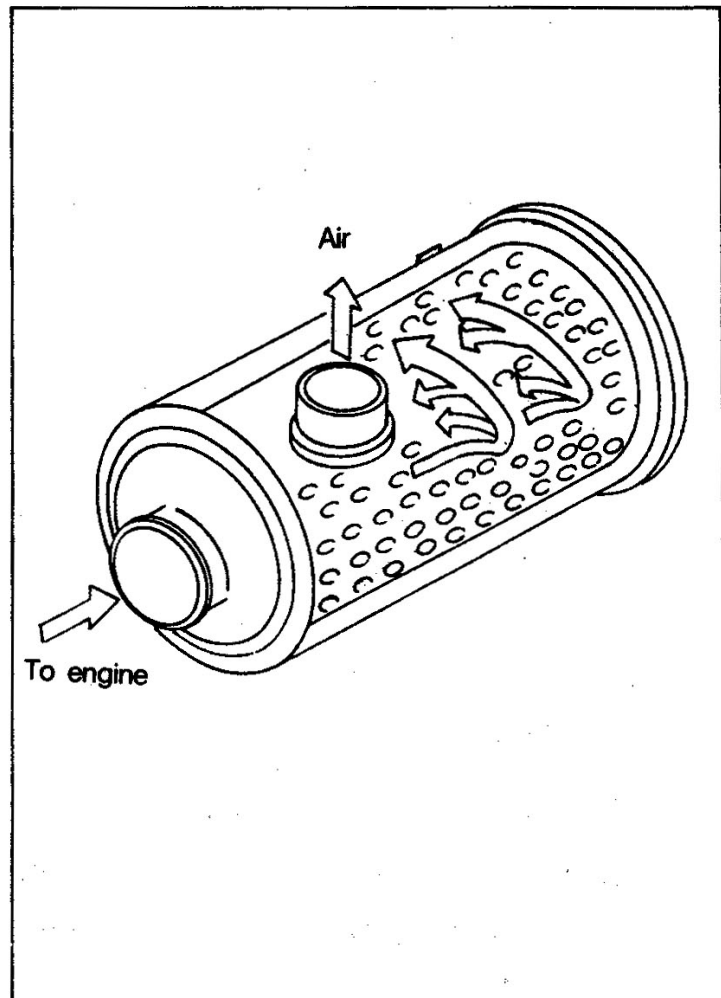

(b) Read Valve

The centrifugally separated particles of dust and dirt are collected at the bottom of the air cleaner. The collected particles of dust and dirt are discharged outside by pulsations of the rubber read valve mounted in the air cleaner. If the engine speed increases (to 800 rpm or more), the read valve will be closed by a high negative pressure in the air cleaner, so no outside air will be drawn in.

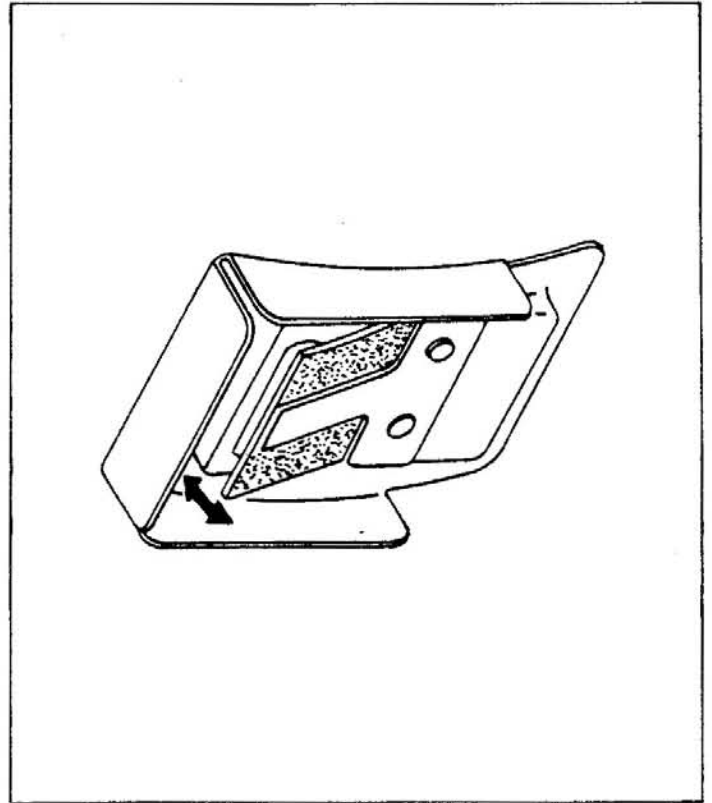

(2) Dust Indicator

The dust indicator, mounted near the outlet of a paper element type air cleaner, operates on the negative pressure of the air drawn into the engine, performing the function of indicating, the time to clean or replace the element.

If dust is collected in the element, the suction resistance increases. When the negative pressure reaches 700mmAq, the signal is pulled down against the pressure of the spring, and the transparent portion of the body changes to red, indicating the time to clean or replace the element.

After the element has been cleaned or replaced, depress the reset button on the top, and the signal will return to its original position.

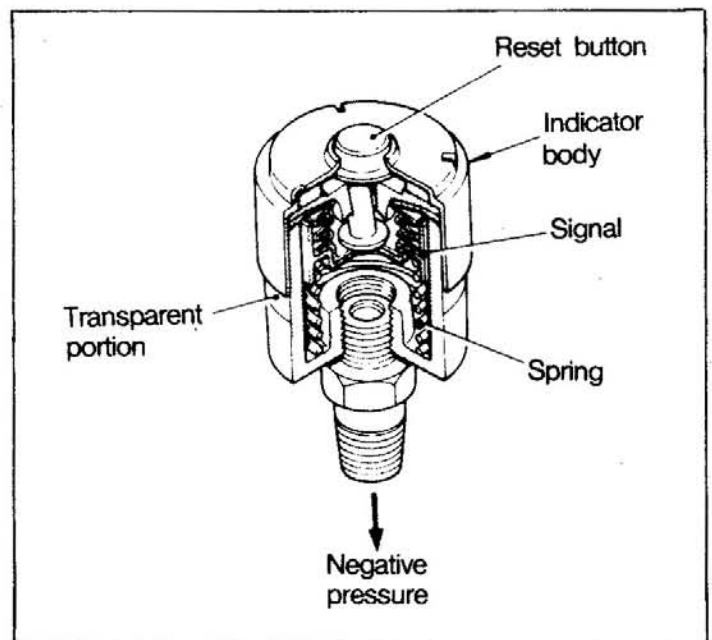

(3) Turbocharger

The turbocharger utilizes the energy of the exhaust gases from the engine to feed more air into the engine, thereby offering the advantages of increased engine output, greater saving in fuel consumption, lower engine noise, etc.

The exhaust gases discharged from the cylinder of the engine are led through the exhaust manifold into the turbocharger and are accelerated in the turbine housing and are blown against the turbine wheel.

Accordingly, the turbine is made to rotate at a speed of scores of thousands of revolutions per minute, and turns the compressor wheel mounted on the same shaft as the turbine wheel. By rotation of the compressor wheel, a larger amount of air than that supplied when no turbocharger is provided is forced into the cylinder of the engine, so a correspondingly larger amount of fuel can be burnt. This increases the effective pressure during combustion (the pressure forcing the piston down) and thus increases the output.

Structurally, the turbocharger may be divided into two broad sections; the turbine wheel section which is driven by exhaust gases and the compressor wheel section which forces inlet air.

The turbine wheel and compressor wheel are supported by bearings. A thrust bearing is mounted on the compressor side. The lubricating oil is derived from the main oil gallery at the front end of the engine and routed through the oil hole provided in the bearing housing. After lubrication of the bearings, the oil is returned to the engine oil pan through the drain port provided at the bottom of the bearing housing.

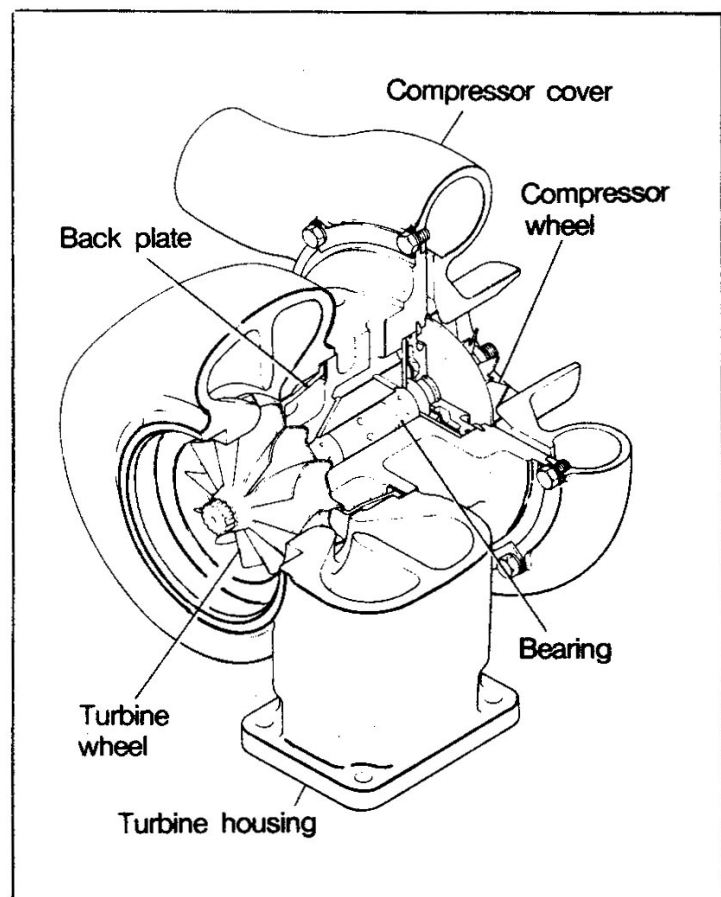
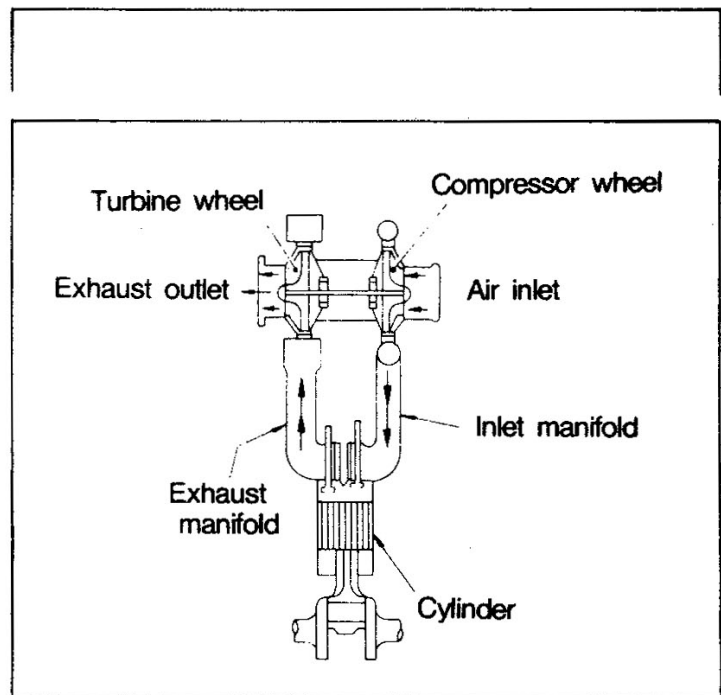

1-3-3 Lubrication

Engine lubrication is accomplished by forced lubrication system using gear pump. The engine oil in the pan is drawn up through the oil strainer by the oil pump and force-fed to the oil filter and oil cooler to lubricate all parts.

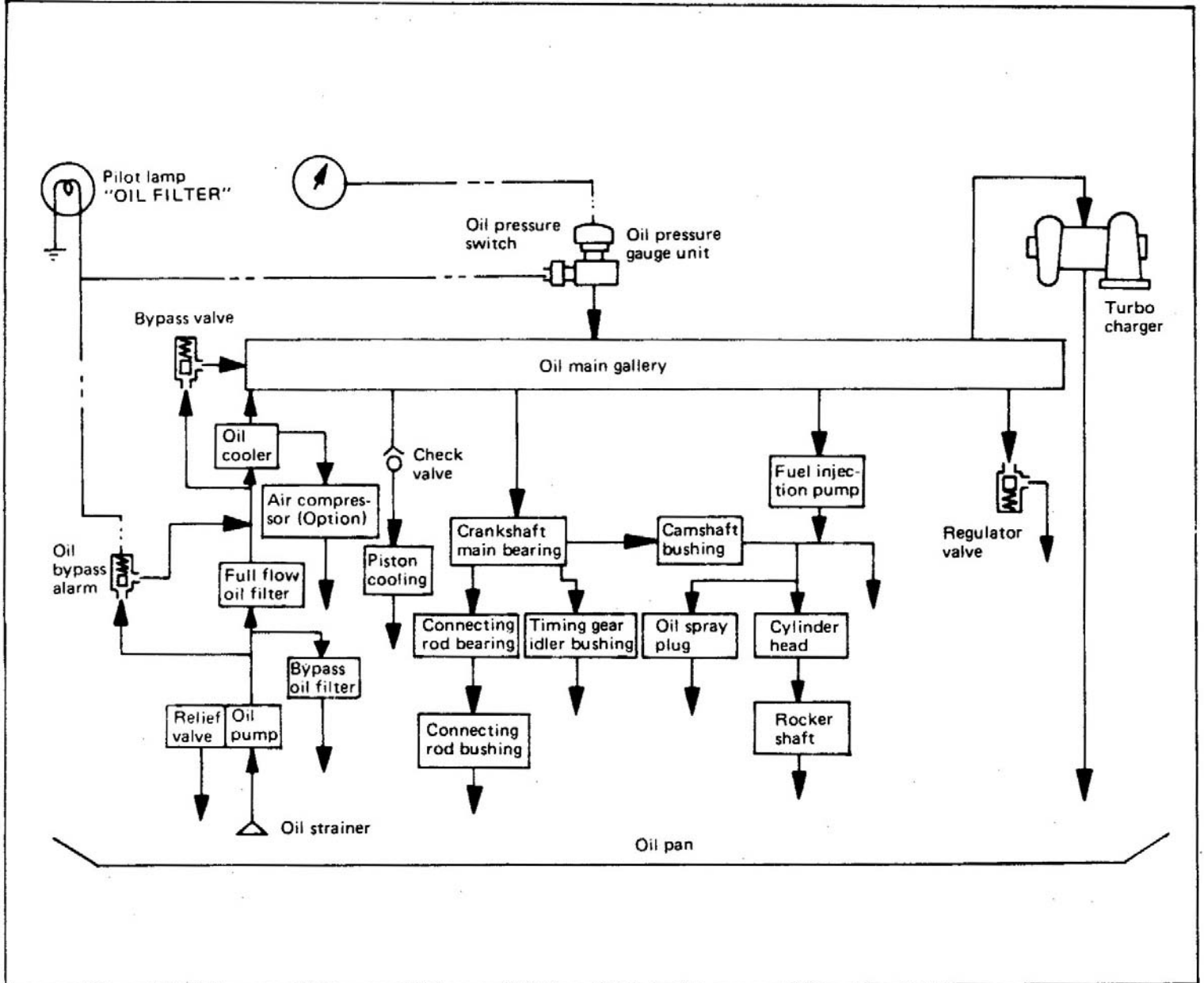

(1) Oil pump

The oil pump is a gear pump. It is mounted on the rear bottom surface of the crankcase and is driven by the crankshaft gear.

An oil strainer is mounted to the suction port of oil pump and an oil pipe mounted to the delivery port.

The crankshaft gear drives the oil pump idler gear and oil pump gear to transmit the rotation to the oil pump drive gear. In the oil pump, the oil pump drive gear is in mesh with the oil pump driven gear. When the oil pump drive gear is driven, the oil pump driven gear is turned in the opposite direction.

At this time, the engine oil is drawn in by the negative pressure produced when the gears turn along the inside of the pump case, and is forced out from the suction side to the delivery side along the gears and case inside wall.

An oil strainer is mounted to the suction port of the oil pump to prevent suction of foreign substances and air from inside the oil pan. The oil pipe mounted to the delivery port sends the engine oil to the crankcase.

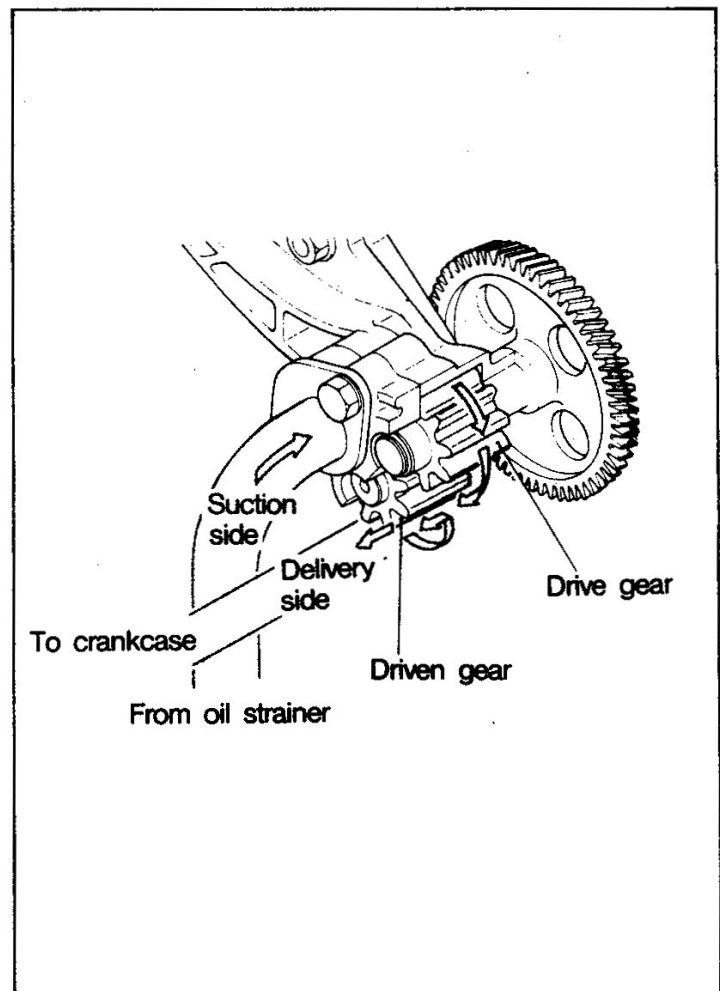
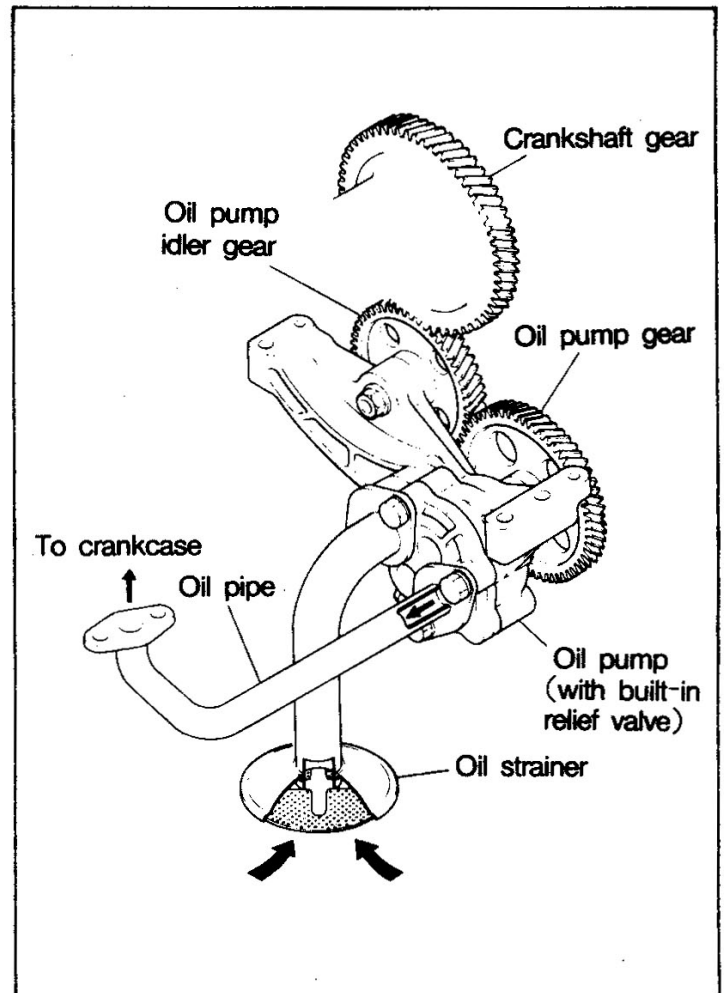

Since the oil pump is driven at speed proportional to the engine speed, the delivery pressure of the oil pump might rise excessively and overload the lubrication system during cold starting, etc. To prevent overloading the lubricating system, the oil pump has a built-in relief valve.

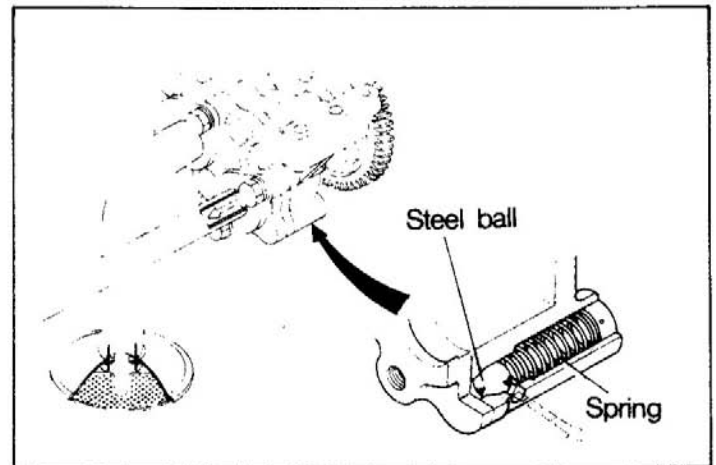

(2) Oil Filter

The oil filter is a double type oil filter consisting of a full flow filter and bypass filter put together as a single assembly. It comes in two types ; the vertical and horizontal types. The element is a filter paper element.

The engine oil forced by the oil pump passes through the oil hole of the crankcase and flows from the oil filter head into the full flow filter and bypass filter. The engine oil filtered by the full flow filter is routed from the oil filter head through the crankcase oil hole to the oil cooler. The engine oil filtered by the bypass filter returns to the oil pan. An oil bypass alarm is provided on the oil filter head.

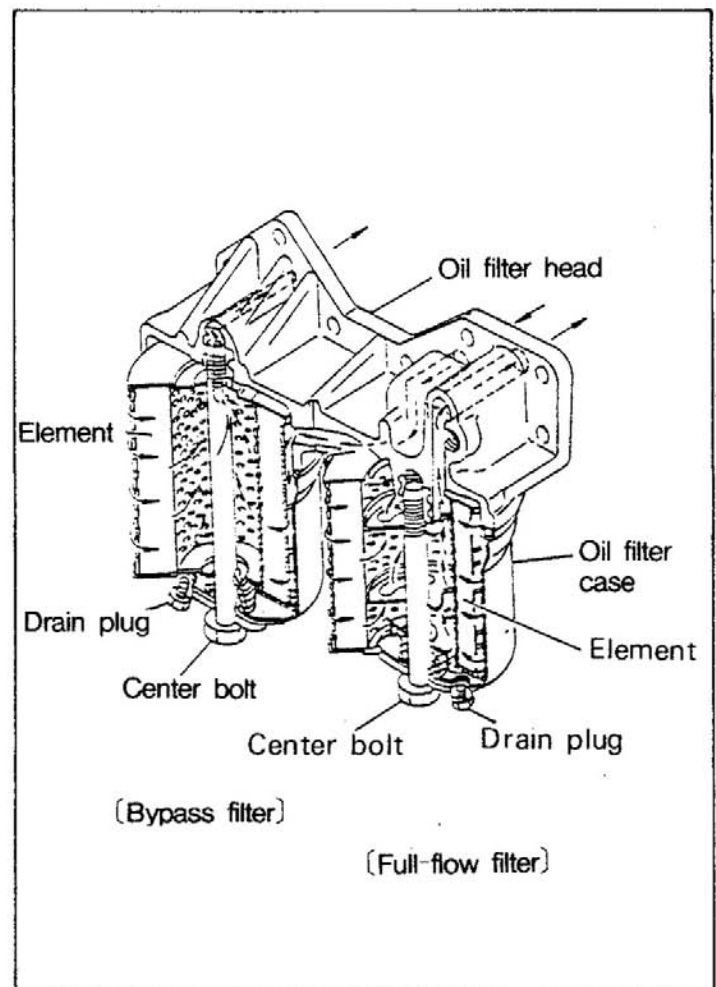

When the oil filter element is clogged and the difference between the filtered and unfiltered oil pressures increases beyond specification, the valve in the oil bypass alarm moves against the spring force, allowing the unfiltered oil to flow to the filtered oil path.

The oil bypass alarm has electric contacts. When the valve opens, the contacts close and the meter cluster pilot lamp of the cab lights to warn the driver.

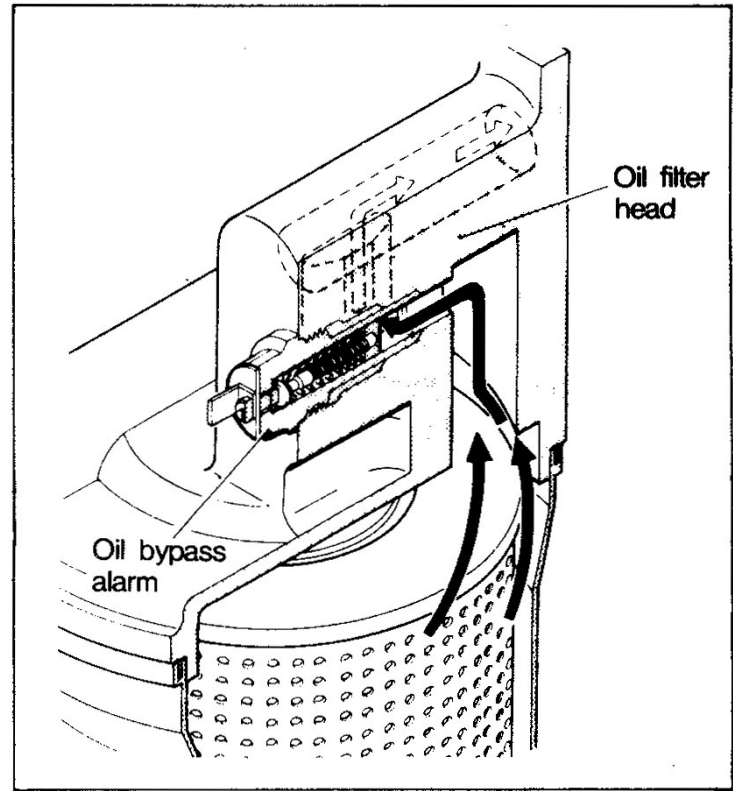

(3) Oil Cooler

The oil cooler is a shell and plate type (multi-plate type) and is mounted to the coolant path on the left side of the crankcase.

The engine oil forced through the oil filter flows through the inside of the oil cooler element, whereas the coolant forced from the water pump flows around the element. The engine oil in the element is cooled or heated before it flows to the main oil gallery.

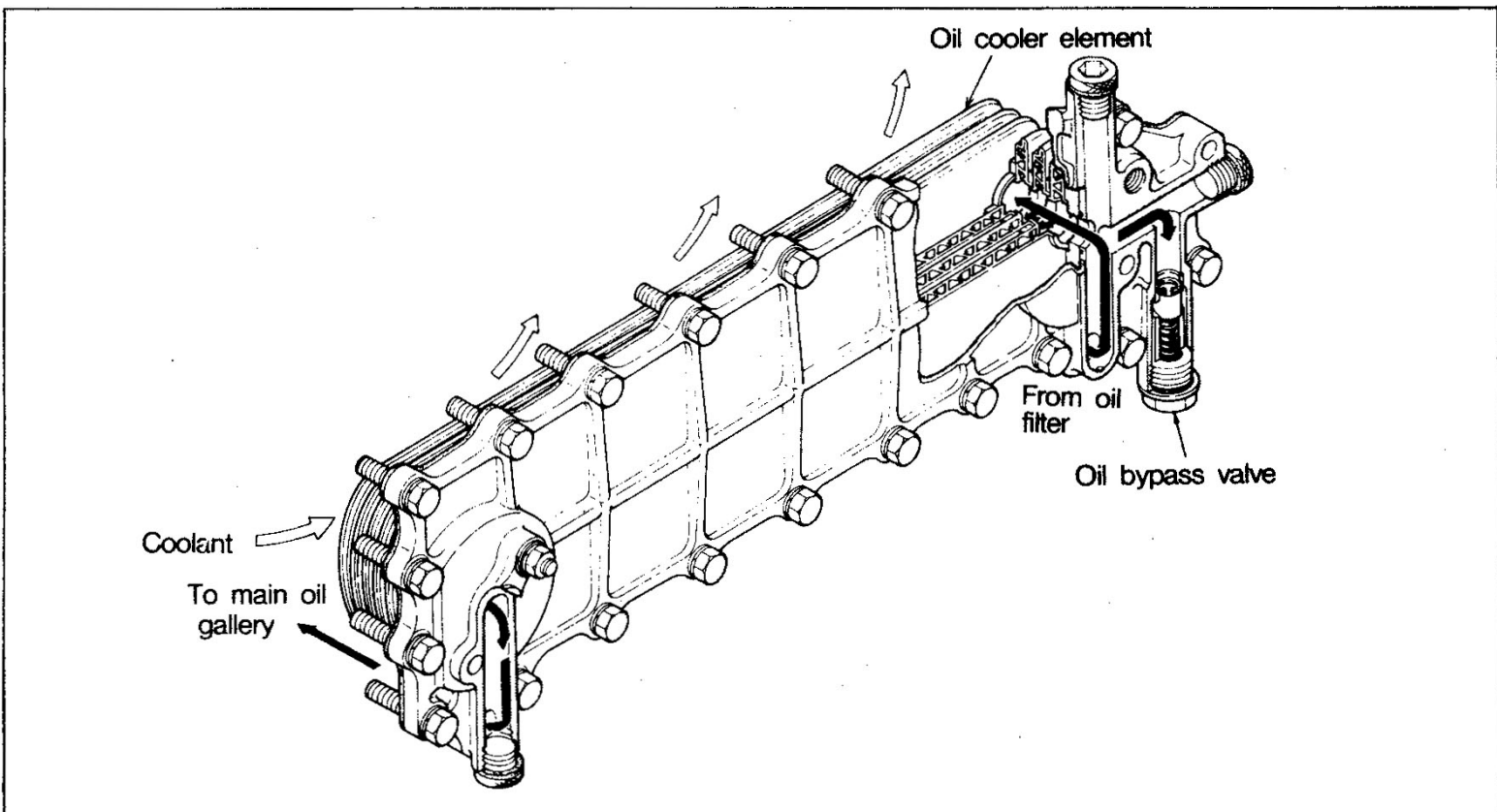

When the oil viscosity is high at low temperatures or when the element is clogged and the element has high resistance to flow, the oil bypass valve provided at the oil cooler opens so that the engine oil flows to the main gallery without passing through the oil cooler.

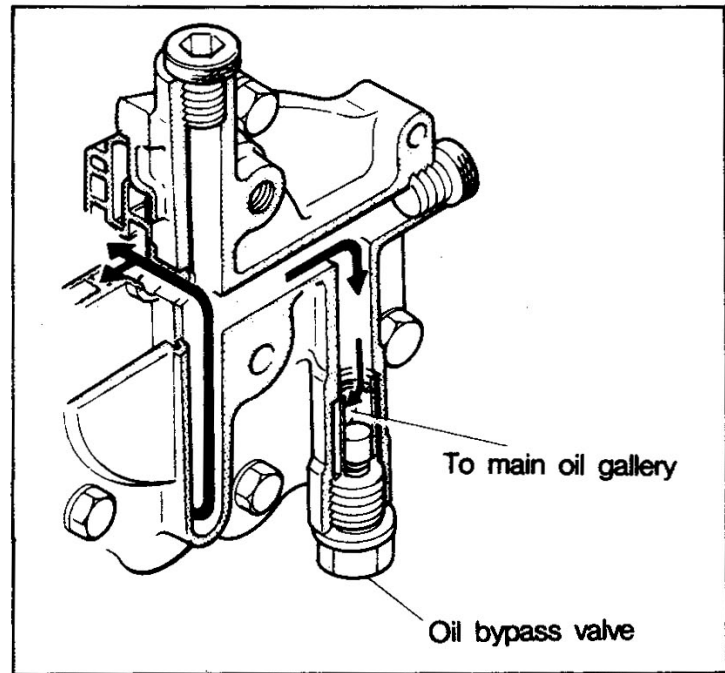

(4) Regulator Valve

The regulator valve is mounted to the main oil gallery in the crankcase. When the oil pressure in the main gallery exceeds specification, the valve accomplishes the function of allowing the engine oil to escape to the oil pan, thereby protecting the lubrication system against overload.

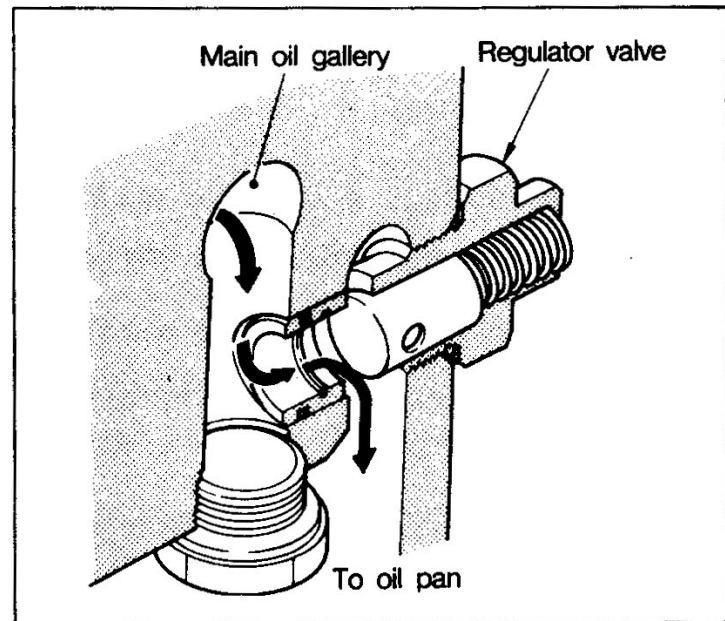

(5) Lubrication of Each Part

The engine oil forced to the oil main gallery lubricates each part as described below.

(a) Main bearing, connecting rod bearing and connecting rod bushing.

The oil hole extends from the oil main gallery to the crankshaft main bearing to lubricate the main bearing.

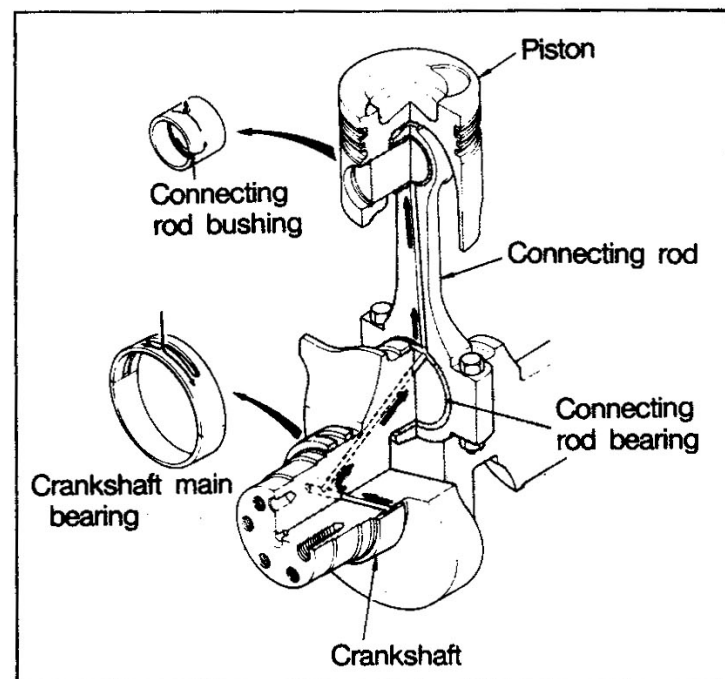

Some of the engine oil which has lubricated the main bearing flows through the oil hole in the crankshaft and lubricates the connecting rod bearing. The oil then flows through the oil hole in the connecting rod and lubricates the connecting rod bushing.

(b) Camshaft

Lubrication of the camshaft bushings is accomplished by the oil flowing through the oil holes to the individual camshaft bushings.

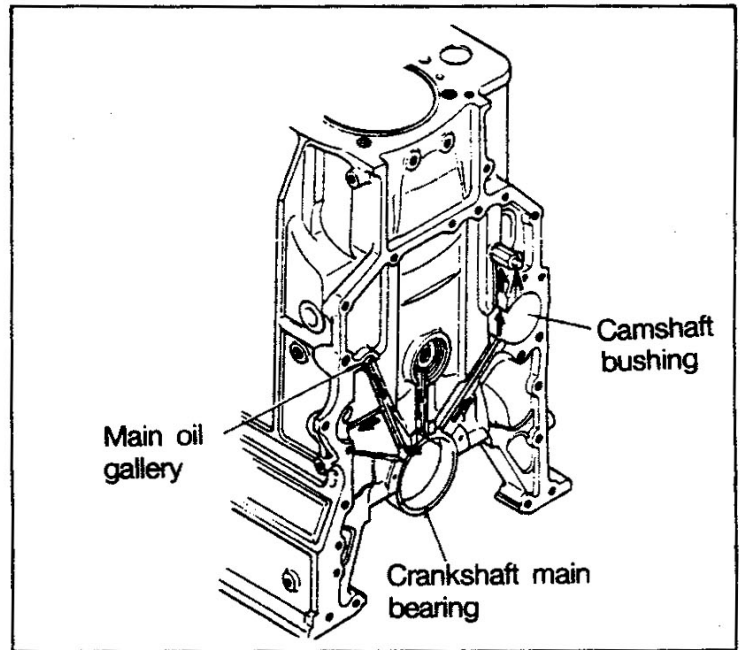

(c) The engine oil that has lubricated the No. 7 camshaft bushing is routed through the oil holes in the top of the crankcase to each cylinder head.

The engine oil forced to the cylinder head flows through the oil holes in the rocker shaft bracket and rocker shaft and lubricates all rocker bushings. The engine oil ejected from the oil hole at the top of the rocker arm lubricates the sliding portion contacting the valve cap, the valve stem portion and the push rod and adjust-

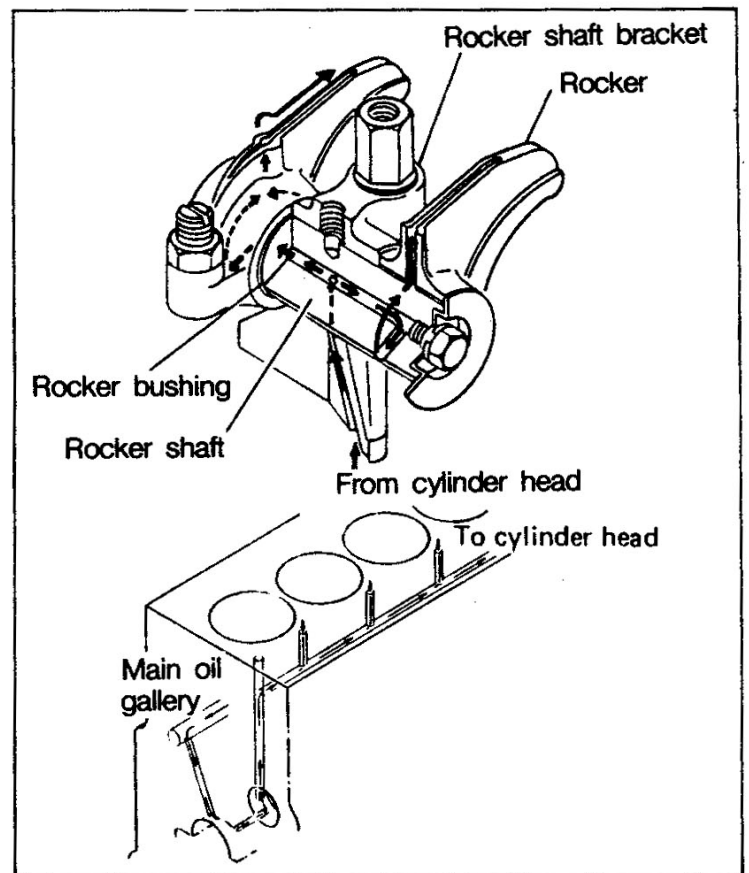

ting screw portion, flows through the cylinder head and crankcase push rod hole, lubricates the tappet and camshaft cam portion, and returns to the oil pan.

(d) Timing gear

The idler shaft bushing of the timing gear is lubricated by oil through the oil hole from the oil main gallery and through the oil hole from the crankshaft main bearing at the rearmost end as shown. Each gear is lubricated by the oil spray plug.

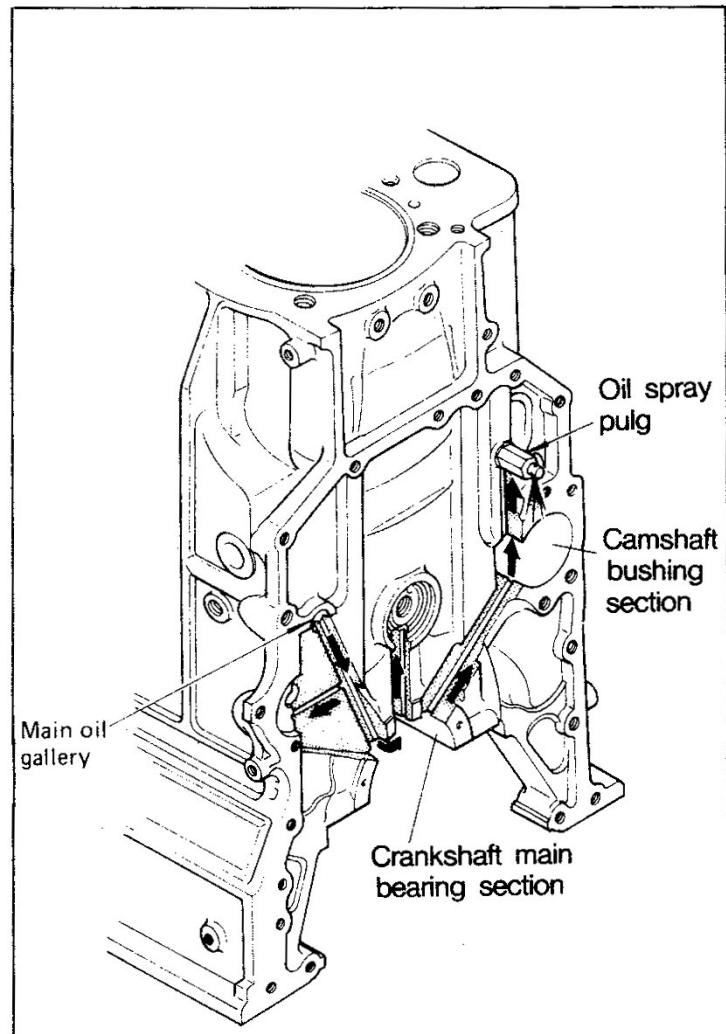

(e) Cooling of piston

The oil jet provided under the main oil gallery for each cylinder sprays engine oil against the reverse surface of the piston to cool the piston.

The oil jet has a check valve which opens and closes at specified oil pressures, preventing reduction of the oil quantity (at low oil pressure) and reduction of the oil pressure.

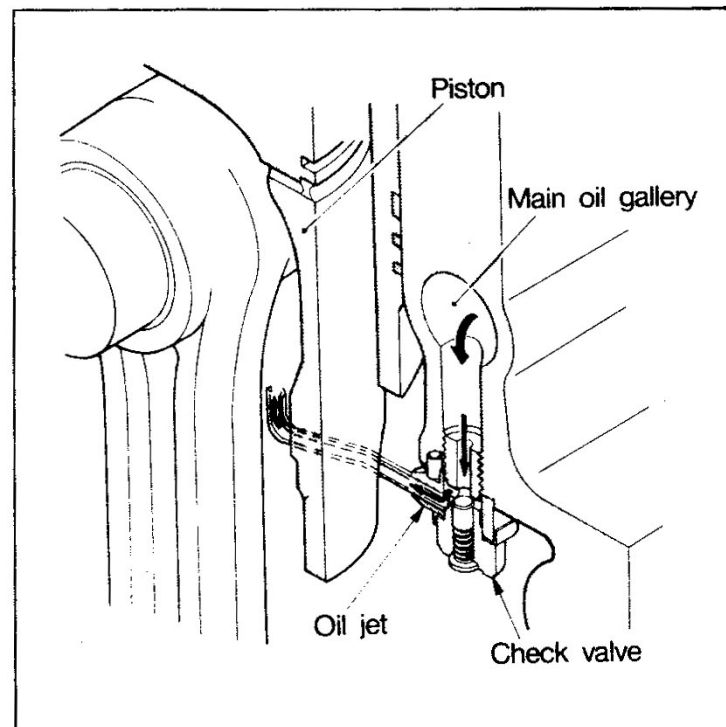

1-3-4 Cooling

The engine cooling system is a water-cooled, forced circulation system using a water pump. Coolant, for the most part, is cooled by the radiator, but the cooling efficiency varies on different applications (as in an enclosed generator room in a building, operations in stationary condition, etc.). Therefore, variation in fan diameter, ventilation type (suction or blow-out type), radiator capacity, etc. have been made available for the individual applications.

Engines for fixed type power generators and those installed in the basement of a building usually employ a city water cooling system instead of radiator cooling system.

The following illustration is the schematic diagram of a radiator cooling system with a suction type ventilation.

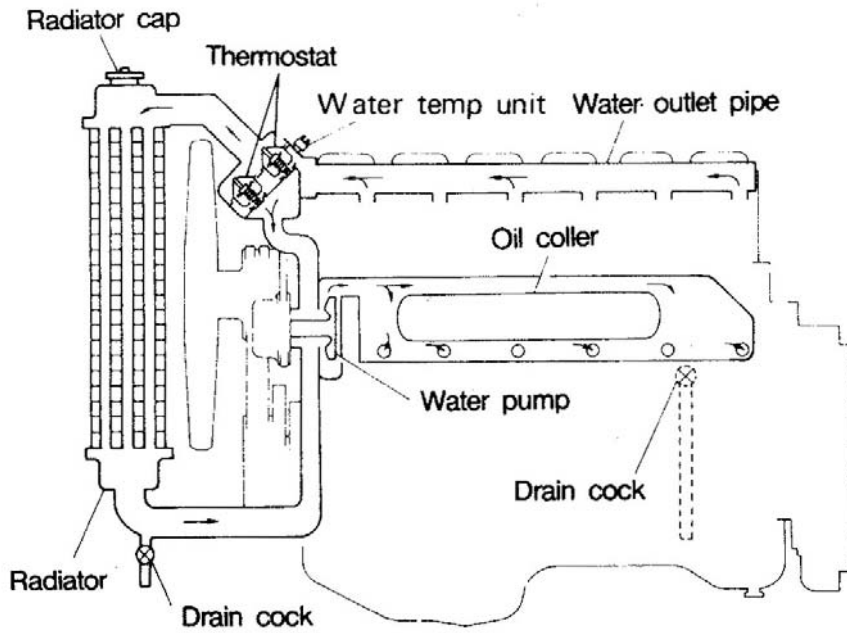

(1) Water pump

The water pump is a centrifugal pump. Mounted on the left side of the crankcase, the pump is driven by the crankshaft pulley via a V belt.

An impeller having a blade is mounted at one end of the water pump shaft and coolant is sealed off by a unit seal.

The ball bearing supporting the water pump shaft is lubricated with grease.

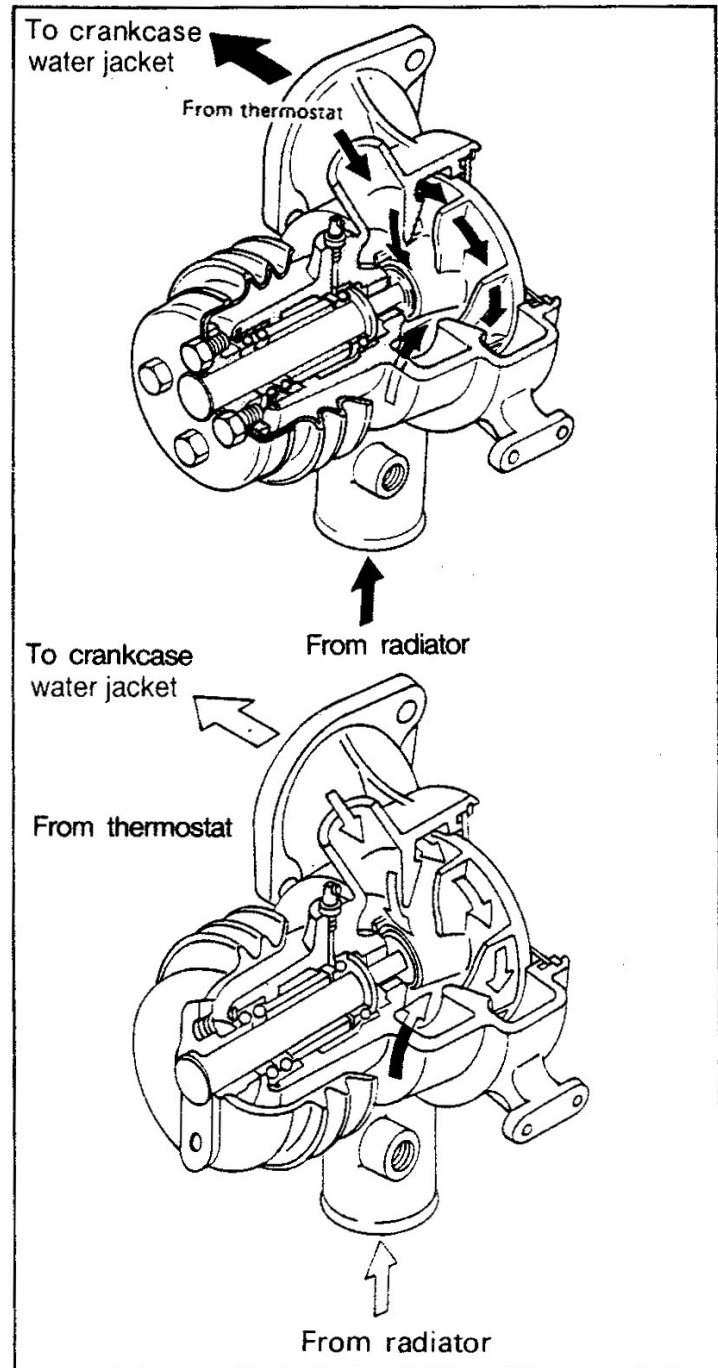

(2) Thermostat

The thermostat is a bottom bypass type with a special wax enclosed in a pellet. When the wax is heated, it changes from solid to liquid and its volume also changes. This change in volume changes the opening of the valve and changes the quantity of coolant flowing into the radiator and water pump (bypass side), thereby controlling the coolant temperature.

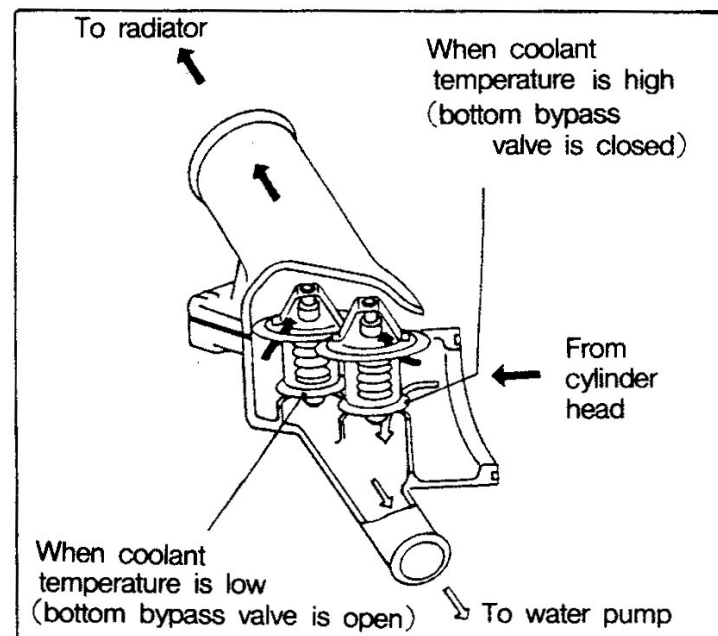

1-3-5 Fuel

The fuel system consists of the injection pump general assembly (injection pump proper, governor, timer, feed pump and coupling), fuel filter, water separator, injection pipe, injection nozzle, fuel leak-off pipe, etc.

The injection pump is driven at one-half the engine speed.

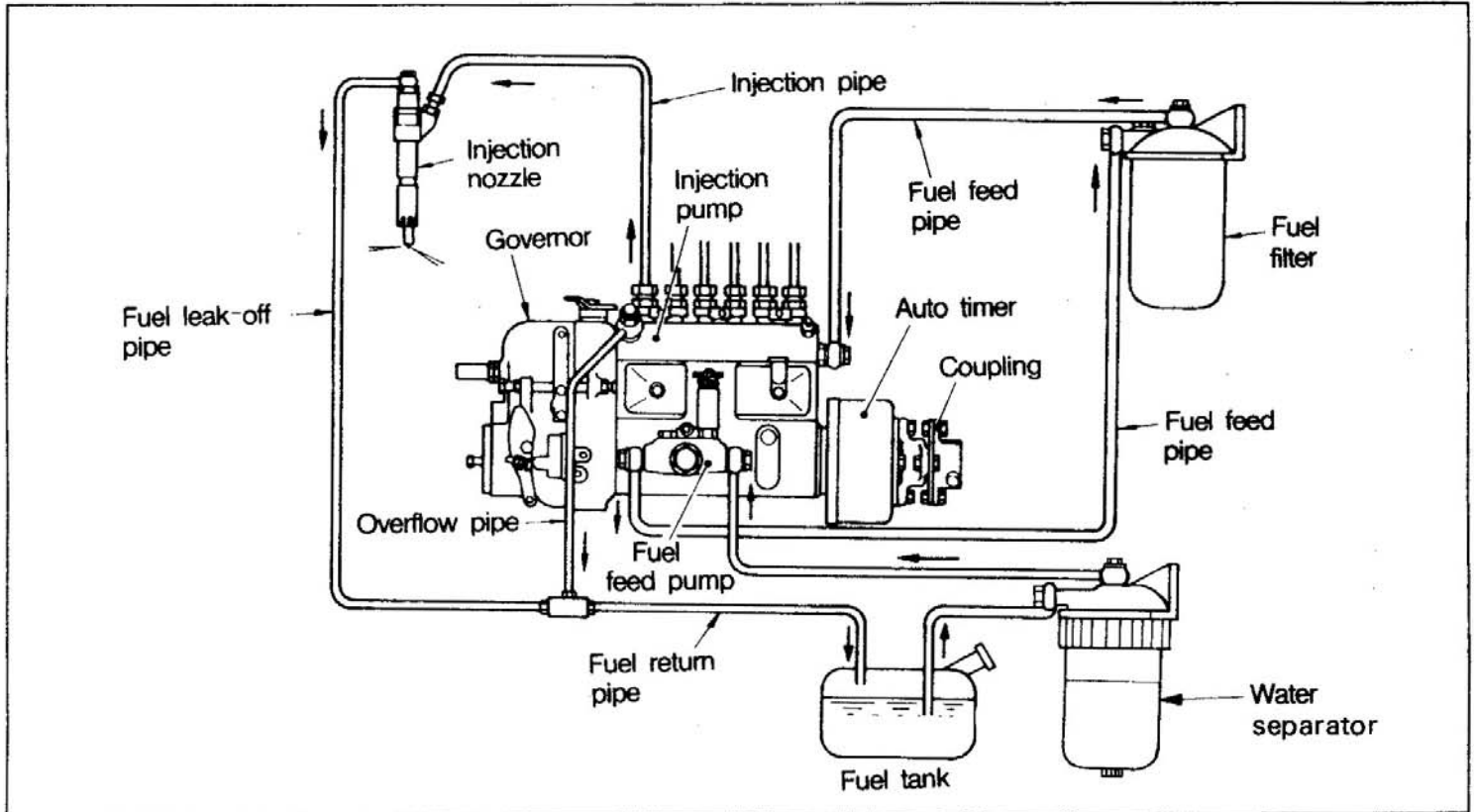

(1) Injection Pump Proper

(a) AD type injection pump [D6AU]

The camshaft driven at half the engine speed is supported by taper roller bearings at both ends. The camshaft has a cam for operating the plunger and a cam for operating the feed pump.

A tappet operating with the pump housing as the guide is in contact with the camshaft. The tappet changes the rotary motion of the cam

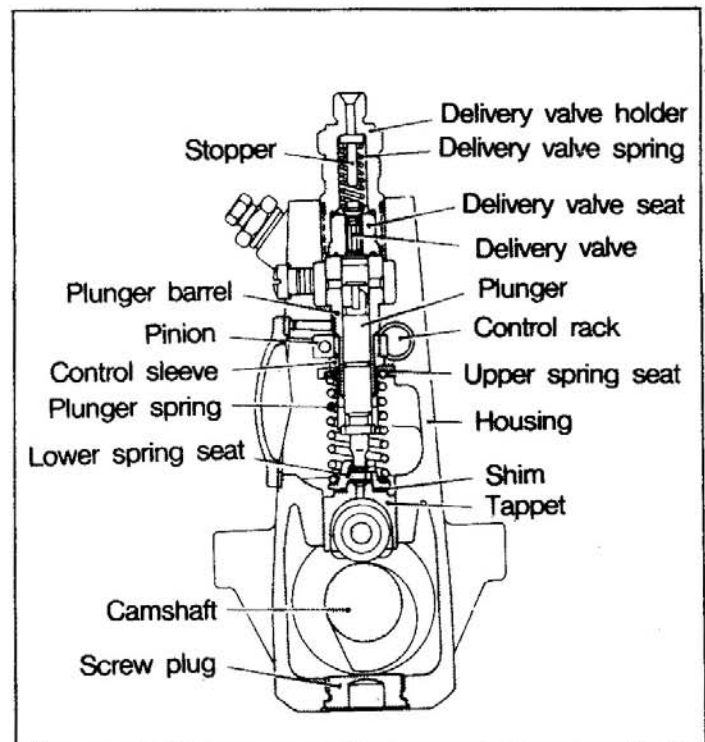

to up-and-down motion which is transmitted to the plunger.

The plunger slides in the plunger barrel secured by the dowel pin of the pump housing.

A delivery valve is mounted on the top of the plunger by the delivery holder. An injection pipe is mounted to the holder.

(b) P type injection pump (D6AZ)

The p type pump is a totally enclosed type and is constructed as shown.

The plunger barrel, delivery valve, delivery valve spring, etc. are secured on the flange sleeve by the delivery valve holder. These are put together as a unit to constitute a plunger block assembly and are mounted to the pump housing.

The cam chamber lubricates the tappet, pump housing, camshaft and governor by the forced lubrication system using engine oil. To minimize the leakage of fuel into the cam chamber, the plunger barrel has an oblique hole for returning the fuel that has leaked to the oil sump. To prevent leakage of the fuel in the oil sump into the cam chamber, O-ring is mounted on the periphery of the plunger barrel.

A deflector is also mounted on the periphery of the plunger barrel to prevent erosion of the pump housing by counter flow of fuel at the end of an injection.

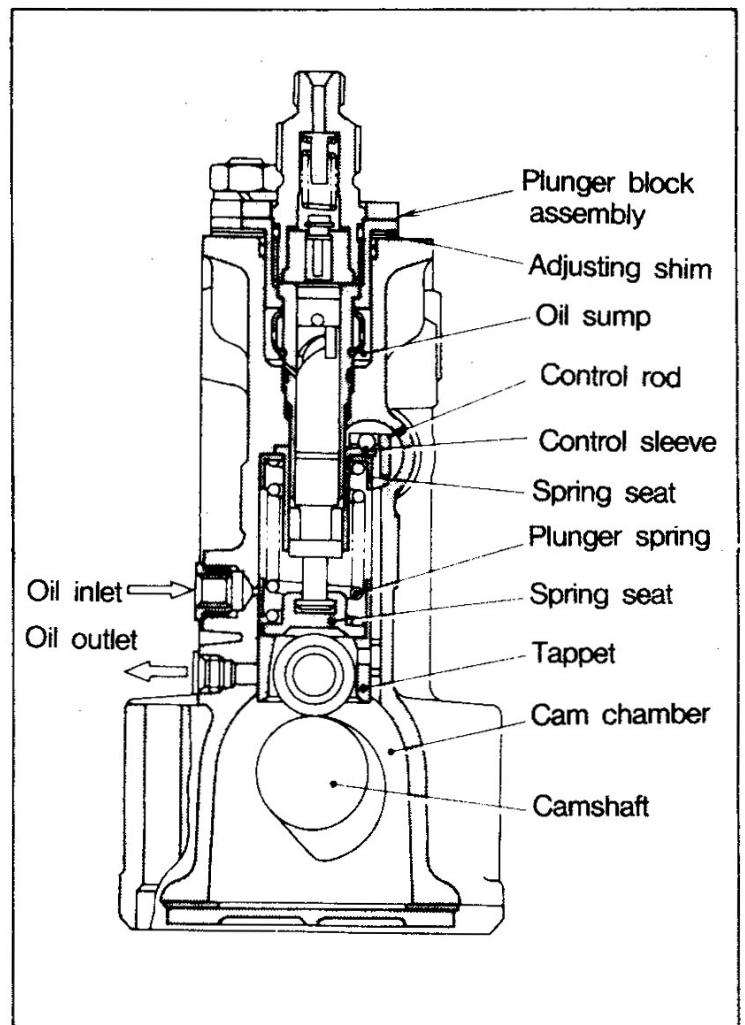

(c) Plunger

The plunger has an oblique groove and a vertical groove, while the plunger barrel has 2 inlet-outlet holes.

Pressurized feeding of fuel oil begins when the plunger, pushed up by the cam of cam shaft, closes the inlet-outlet holes of plunger barrel. When the plunger is further pushed up, fuel oil is discharged through the vertical groove of plunger from the inlet-outlet holes.

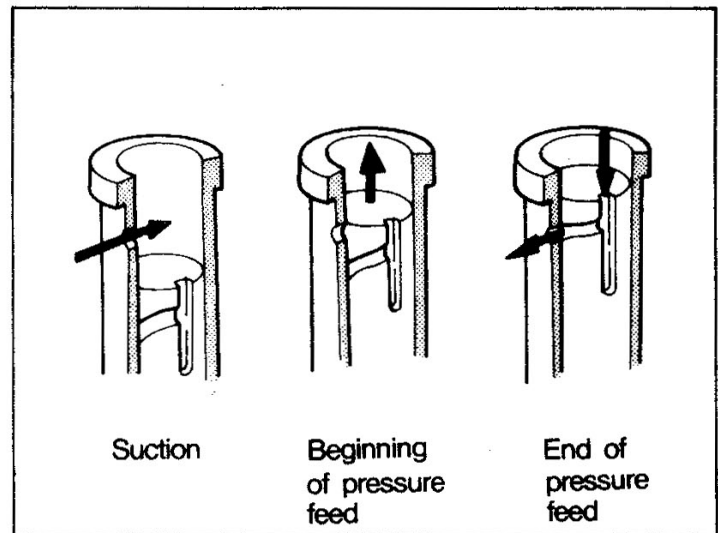

A deflector is installed on the periphery of the plunger barrel so that high pressure fuel oil discharged from inlet and outlet ports will not erode the pump housing. Fuel injection volume is controlled by the governor which moves the control rod(or the control rack) left and right and rotates the control sleeve which engages with the control rod(or the control rack and pinion). Since the driving face of plunger meshes with the control sleeve at the lower part thereof, the plunger turns with the rotation of control sleeve and injection volume is controlled through the changing of the effective stroke.

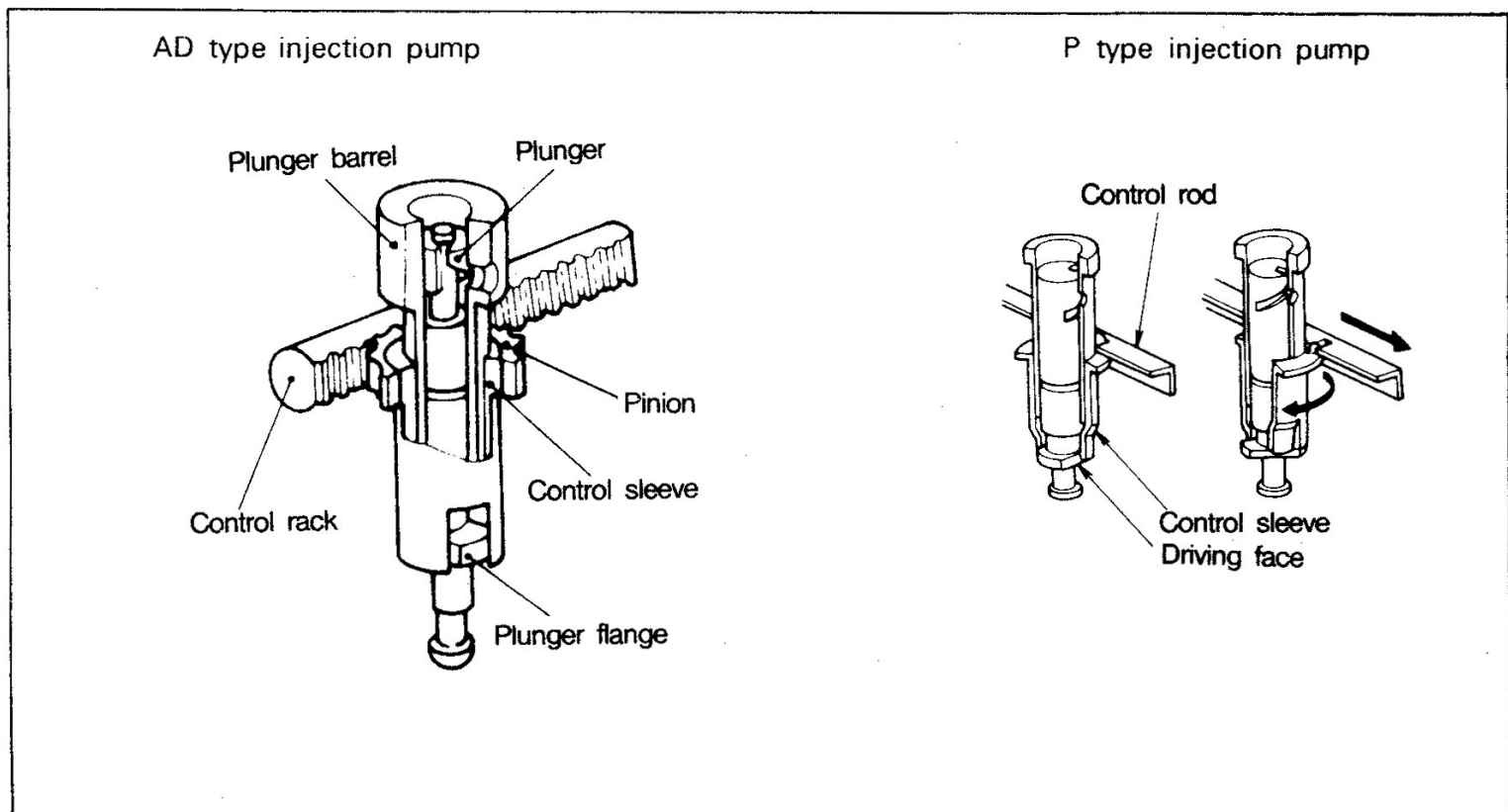

The effective stroke means the length of the plunger stroke from the time when the upper end of plunger closes the inlet-outlet holes of plunger barrel until the oblique groove of plunger opens to the inlet-outlet holes. When the effective stroke stands at zero, it indicates that no fuel injection takes place.

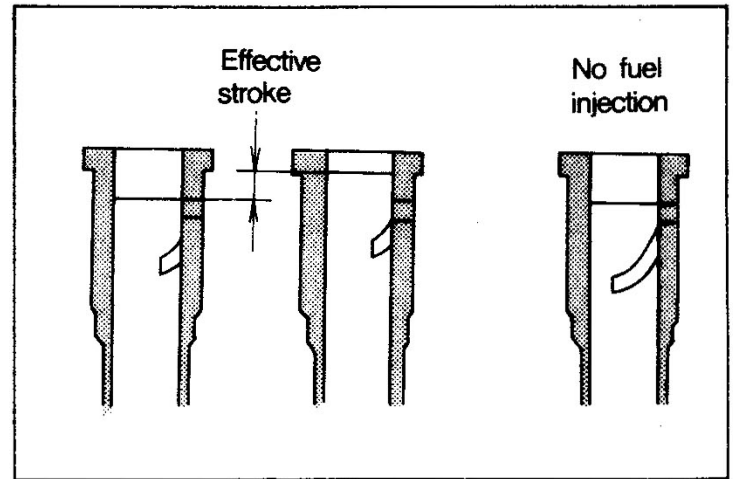

(d) Delivery valve

The fuel highly pressurized by the plunger pushes the delivery valve up and gushes out. When delivery of the fuel under pressure by the plunger is completed, the delivery valve is pushed back by the delivery valve spring and closes the fuel passage to prevent counter flow of the fuel.

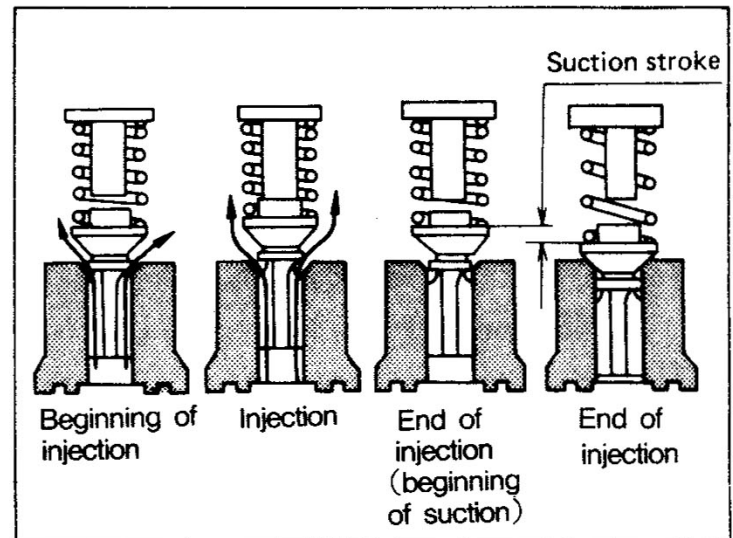

The delivery valve is further brought down until it is held against the seat surface tightly. The amount of fuel corresponding to the stroke during the period is drawn back from above to instantly lower the residual pressure in the line between the delivery valve and nozzle. The draw-back effect improves the cutting of fuel from the nozzle and prevents after-injection dripping.

A delivery valve stopper, provided on the top of the delivery valve spring, limits the lift of the delivery valve to prevent the surging of the valve during high speed operation. It also reduces the dead volume between the delivery valve and nozzle and stabilizes the injection rate.

(e) Overflow valve

When the fuel pressure in the injection pump exceeds a predetermined pressure, the steel ball in the overflow valve is pushed up to let the fuel flow out from the injection pump and return to the fuel tank, thereby stabilizing the fuel temperature and temperature distribution in the injection pump and maintaining the injection rate into each cylinder constant.

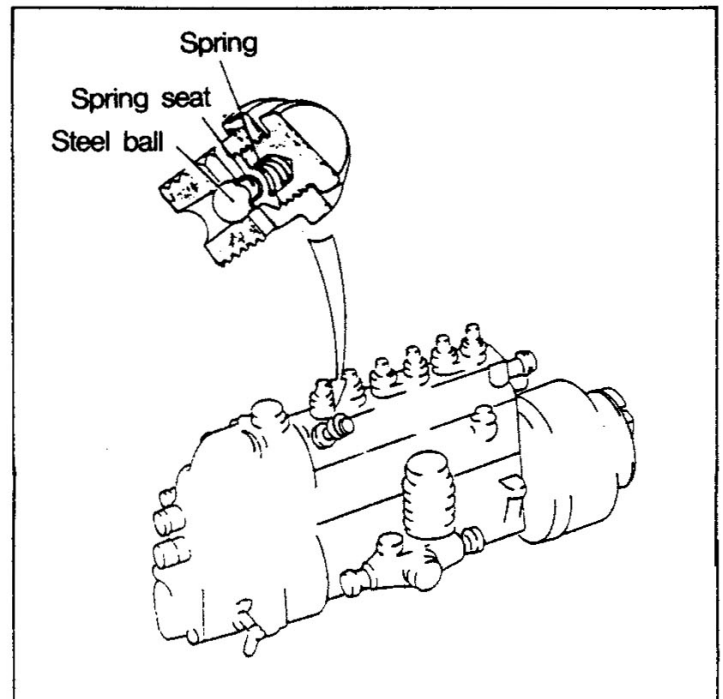

(2) Governor

(a) RSV type governor

The RSV type governor is a centrifugal type all-speed governor coupled to the cam shaft of the injection pump. The governor not only controls the maximum and minimum speeds but also automatically controls the engine speed at any intermediate speed position.

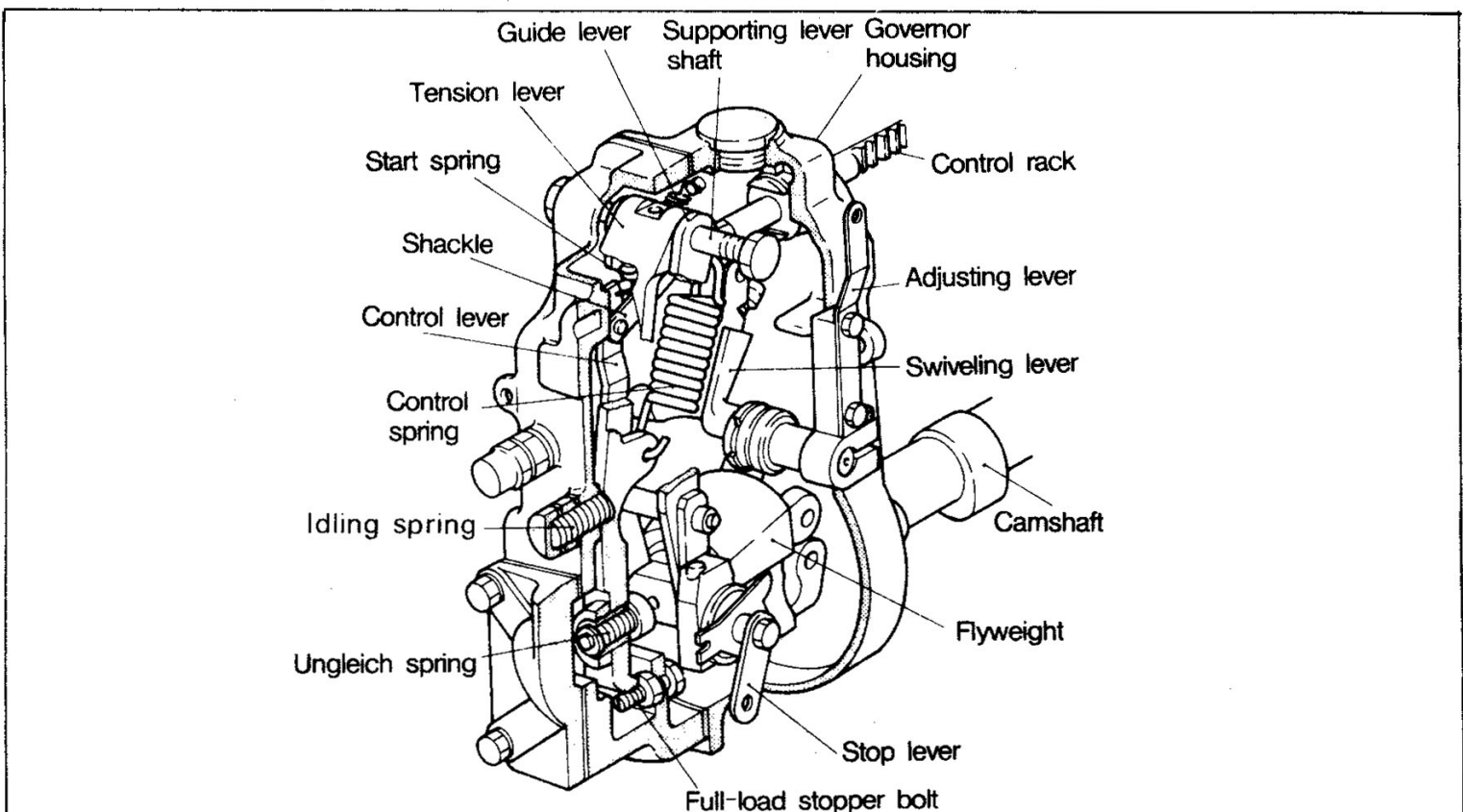

The governor, as shown, consists of flyweights mounted to the injection pump camshaft. When the flyweights turning on the flyweight supporting shaft open outward, the roller mounted to the end of flyweight arm pushes the end of the sleeve in the axial direction. The governor sleeve, being made integral with the control block through a bearing, moves only in the axial direction.

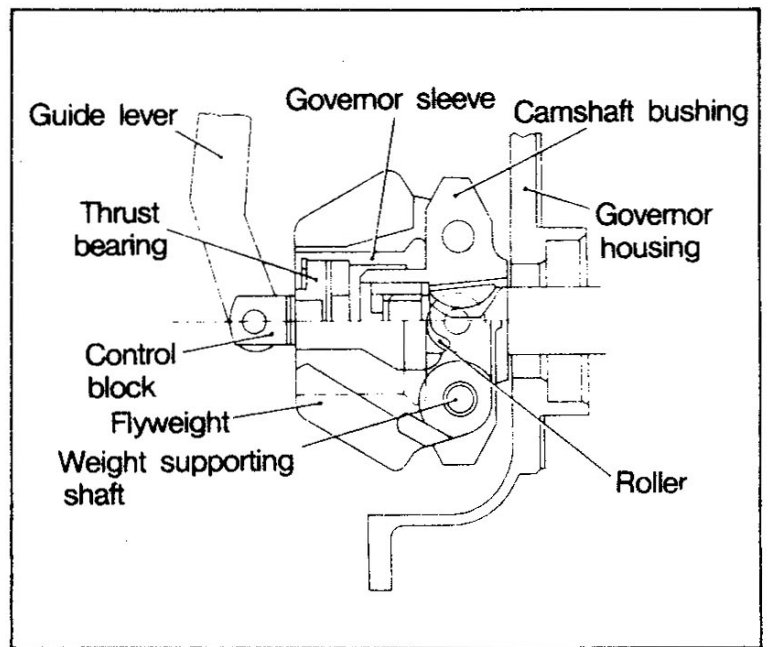

The control block, mounted to the guide lever hung on the supporting lever shaft of the governor cover, prevents rotation.

The control lever is mounted to the middle of the guide lever by the shaft with the bottom end as the fulcrum, whereas the top of the lever is coupled through the shackle to the control rack.

The start spring, attached to the top end of the control lever, always pulls the control rack in the direction that fuel is increased.

The turning shaft of the swiveling lever is fitted into the bushing of the governor cover and its center is eccentric with respect to the mounting position of the control spring installed to the tension lever. The control spring is installed to the end of the swiveling lever. When the control spring receives tension, the bottom end of the tension lever touches the adjustable full-load stopper bolt.

When the angle of the adjusting lever is changed, the angle of the swiveling lever is also changed and the tension of the control spring changed. This is because the turning center of the swiveling lever and the mounting position of the control spring installed to the tension lever are eccentric to each other as mentioned above.

An adjusting screw is also mounted to the swiveling lever. Adjustment of the screw changes the tension of the control spring, thereby making it possible to adjust the speed regulation.

An Ungleich spring is provided in the bottom portion of the tension lever. Adjust the tension of the spring by adding or removing shims.

An idling sub spring adjustable from outside is provided in the middle of the governor cover. During idling, the spring always keeps in contact with the tension lever to maintain a constant idling speed.

The stop lever, mounted through the supporting lever to the bottom end of the control lever, returns the control rack to the stop position with a slight pressure irrespective of the adjusting lever position.

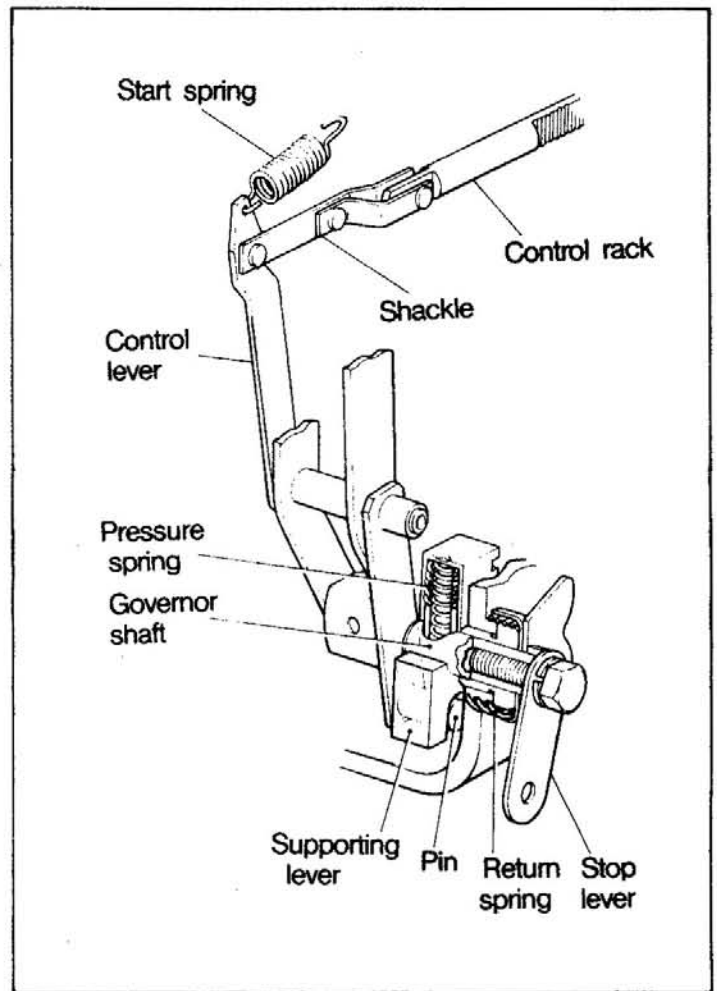

1) Start of engine

When the adjusting lever is moved to the start position (until it touches the maximum speed stopper), the swiveling lever which moves with the adjusting lever pulls the control spring and moves the tension lever until it touches the full-load stopper bolt.

At that time, the flyweights are stationary, and the start spring with weak tension pulls the control lever in the direction that fuel is increased.

At the same time, the control block and governor sleeve push the flyweight roller to the left.

As the result, the tension lever and control block are spaced that much apart, and the corresponding amount of fuel is supercharged to facilitate starting.

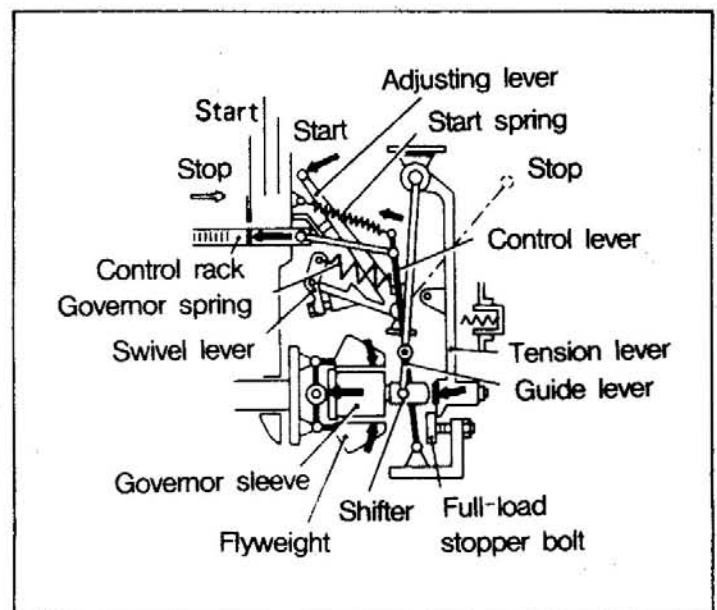

2) Idling control

Once the engine is started and the adjusting lever returned to the idling position, the tension of the control spring is drastically reduced.

Now the flyweights can move outward even at a low speed, so the tension lever is pushed back until it touches the idling sub spring and places the control rack at the idling position. In this state, the centrifugal force of the flyweights and the weak-state control spring and idling sub spring achieve balance and maintain smooth idling.

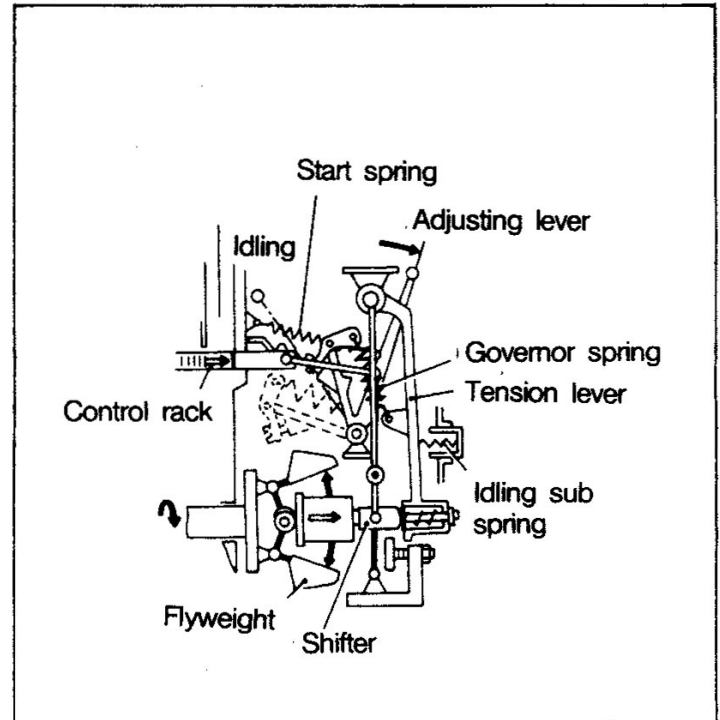

When the speed falls, the centrifugal force decreases, the flyweights move inward, and the idling sub spring pushes the tension lever to the left and moves the control rack in the direction that fuel is increased.

If the speed falls radically, the start spring with weak tension acts and moves the control rack in the direction that fuel is increased to maintain the idling speed.

3) Maximum speed control

When the adjusting lever is moved to the full-load position, the tension of the control spring is increased and pulls the tension lever until it touches the full-load stopper bolt.

When the engine exceeds the specified speed, the centrifugal force of flyweights becomes larger than the force of the control spring pulling the tension lever. So the tension lever is moved to the right and moves the control rack in the direction

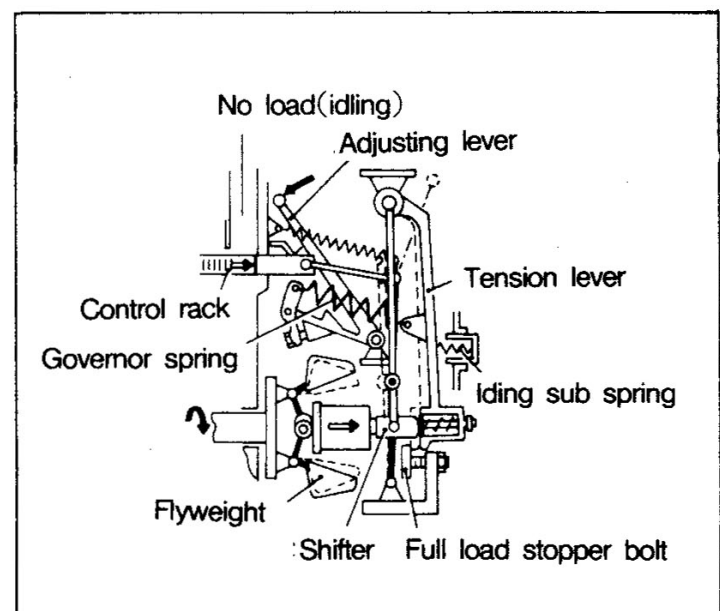

that fuel is reduced, thereby preventing the engine from exceeding the specified speed.

If the speed further increases, the centrifugal force of flyweight increases and pushes the tension lever to the right and also compresses the idling sub spring to pull the control rack back to the no-load maximum speed position, thereby preventing over-speed operation of the engine.

The RSV type governor controls the entire speed range from idling to maximum speed. If load increases or decreases at a certain speed determined by the position of the adjusting lever, the governor automatically functions and maintains the engine speed constant at all times.

4) Ungleich operation

The Ungleich device controls fuel injection in such a way as to match the engine performance (the required injection varies with engine speed).

The air intake rate of the engine falls as the engine speed increases. The injection pump, on the other hand, increases the per-stroke injection as the speed increases, even with the control rack at the same position.

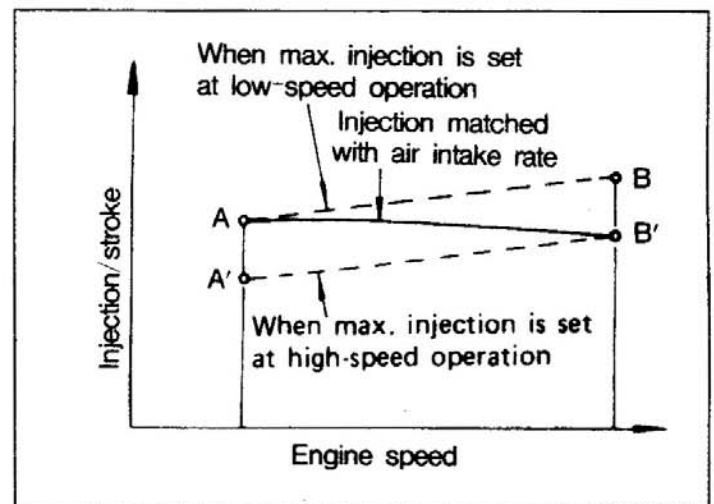

Therefore, if full load is set at point A to derive enough output at low speeds, the injection will reach B as the speed increases, and the engine will produce black smoke.

If full load is set at point B' to prevent black smoke, the low speed injection will come down to A', allowing combustion of more fuel.

So the Ungleich device accomplishes the function of setting full load at point A to derive the largest possible torque in the low speed range, and changing it to adjust the injection to point B' in the high speed range.

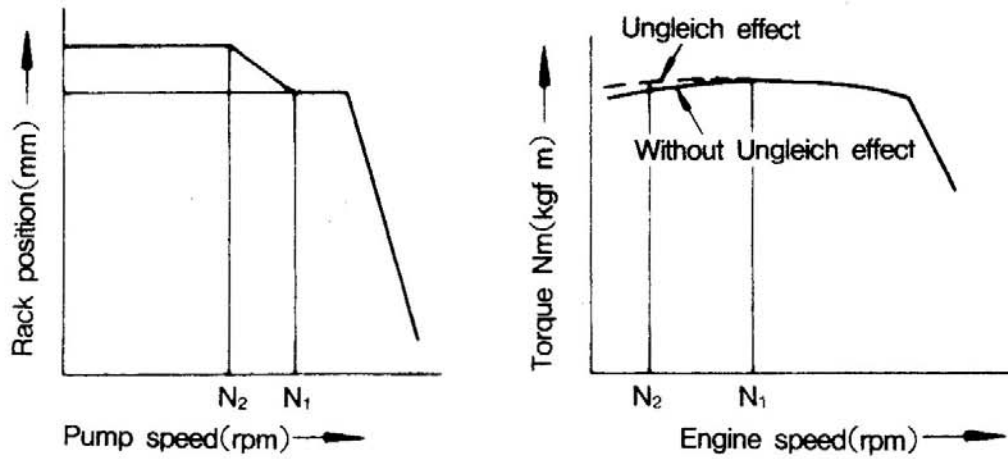

When the engine speed is low and the centrifugal force of flyweight smaller than the pressure of the Ungleich spring, the control block is moved as much as the Ungleich stroke to the left, so the control rack moves in the direction that fuel is increased to increase the torque of the engine at low speeds.

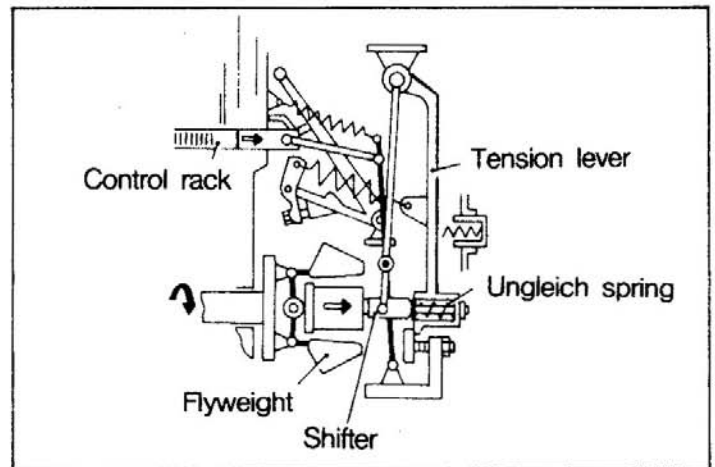

As the engine speed increases, the centrifugal force of flyweight increases. If it becomes larger than the pressure of the Ungleich spring, the Ungleich spring is slowly compressed before the start of high speed control, and the control rack moves in the direction that fuel is reduced. The Ungleich stroke is completed at the position where the control block directly touches the tension lever.

5) Engine stop

When the stop lever is moved to the stop position, the control rack is moved to the stop position to stop the engine regardless of the position of the adjusting lever.

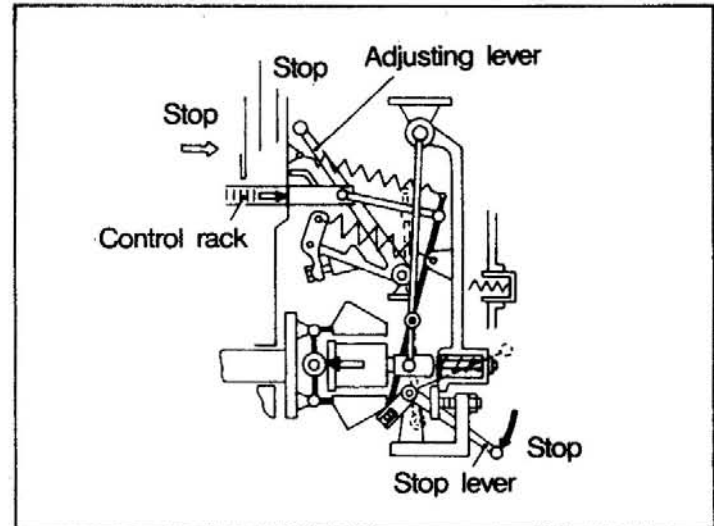

6) Operation of torque spring

Construction machinery engines are often subjected to a large load during operation, and reduced speeds often lead to stalls. To prevent this, a torque spring is provided.

When the adjusting lever is fixed in the lever set position, a sudden increase of load, if no torque spring is provided, will move the control rack along the B-D curve as the speed falls. The rotational displacement at the time may be expressed as P_1 .

If a torque spring is provided, the control rack moves along B-C, and the rotational displacement at the time may be expressed as P_2 . Therefore, large changes occur in P_2 and engine speed, and because of increased fuel injection, the engine torque increases, and large combustion noise warns the operator of the increased load, enabling him to take proper action to prevent stopping the engine.

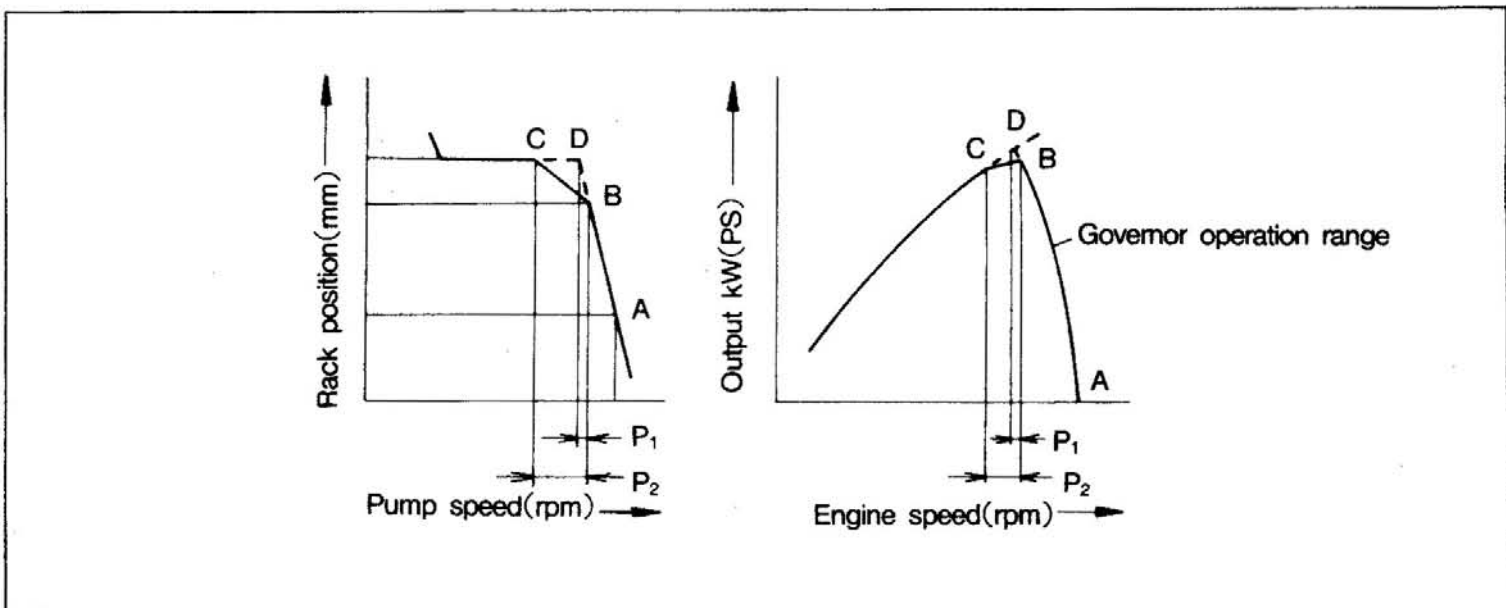

In an abrupt increase of load occurs when the engine is running at continuous rating, the engine speed falls. So the flyweights are moved inward and the tension lever pulled to left by the control spring, causing the control rack to move in the direction that fuel is increased.

At the time, the tension lever pin pushes the bottom of the torque control lever, and the lever moves with the pin "A" as the fulcrum, whereas the portion "B" is pushed to right. As the result, the torque spring performs the function of reducing movement of the tension lever.

(b) RFD type governor

The RFD type governor is a minimum-maximum governor which controls only the minimum and maximum speeds.

The RFD type governor make it possible to increase or reduce fuel by the load control lever which operates the control rod. Any desired speed can be set as a displacement of the speed control lever changes the tension of the governor spring.

Because of the construction described above, the RFD governor can be operated as an all-speed governor by holding the load control lever in the FULL position and operating the speed control lever.

On the top of the governor, an engine stop lever is provided which creates

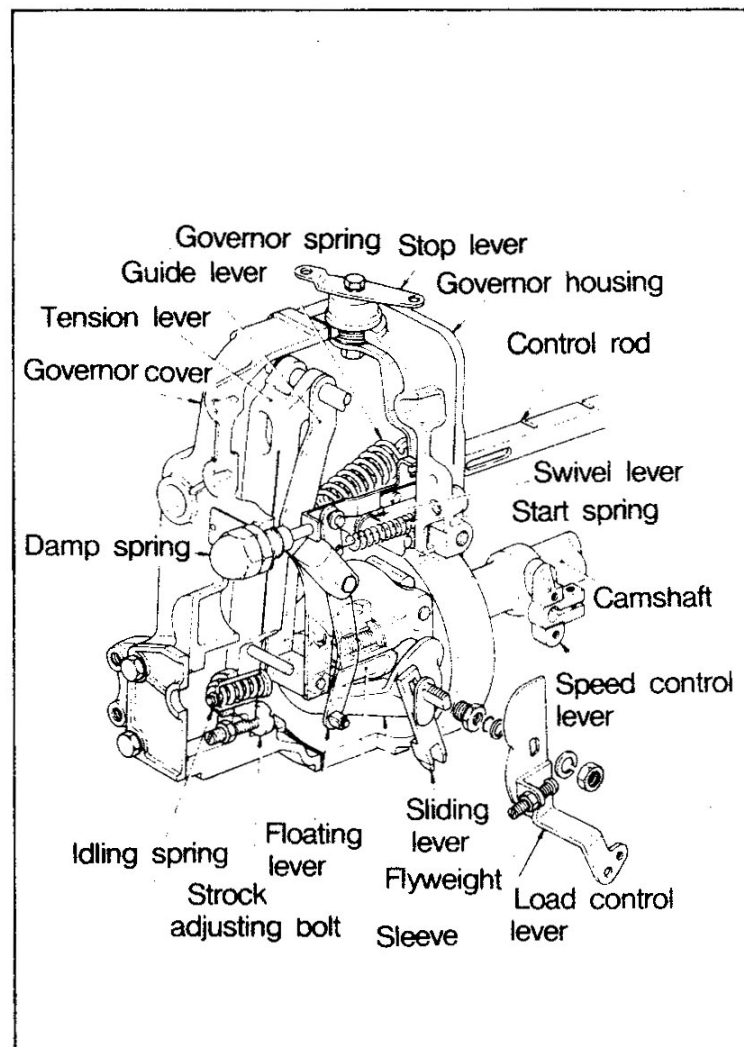
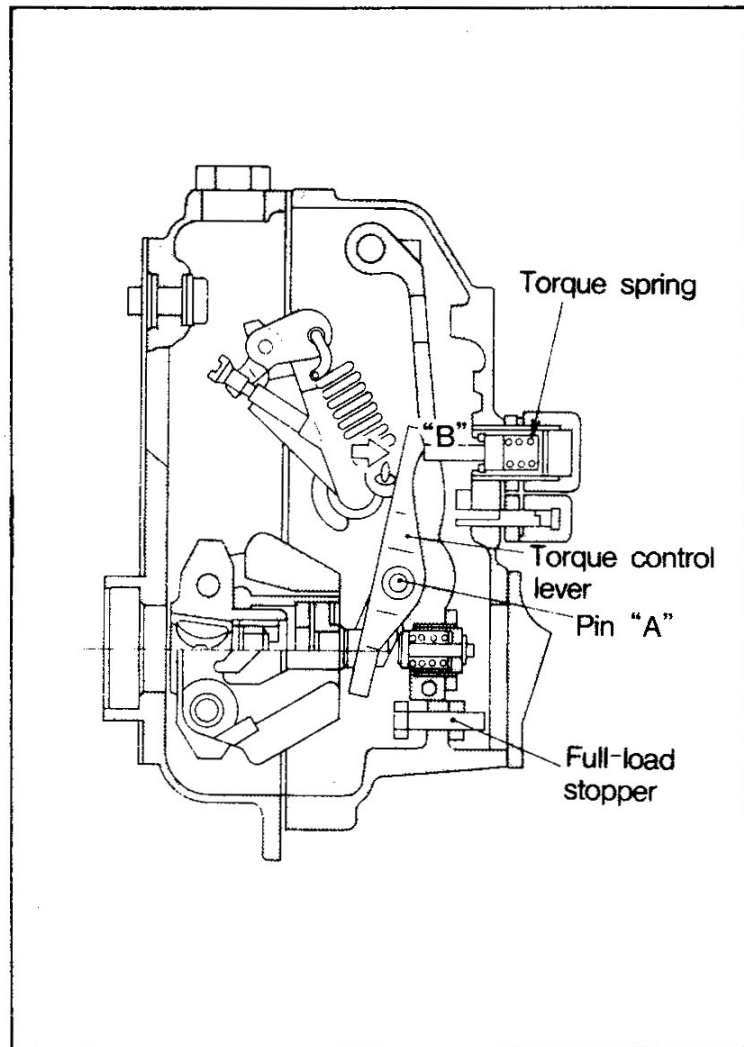

a no-fuel injection state for stopping the engine. A cancel spring is provided to make sure that when the lever is operated, no undue force is applied to the link.

1) Start of engine and control of idling

When the engine is stationary, the flyweight is in closed position, pushed by the governor spring, idling spring and start spring.

If, in this condition, the load control lever is moved all the way to the FULL position (in the direction of greater fuel delivery), the start spring and idling spring will cause the control rod to move to the fuel increasing position.

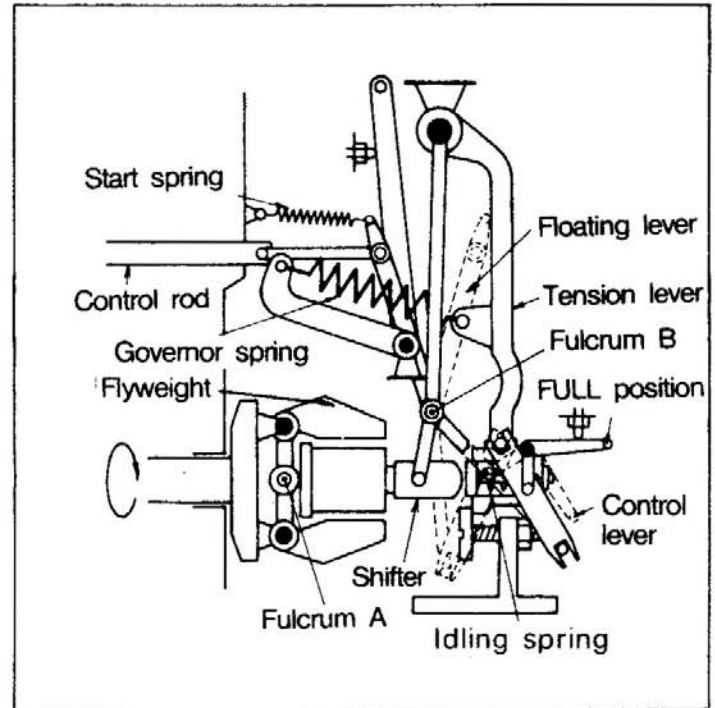

If the load control lever is placed to the idling position after the engine has started, the floating lever will move the control rod back to a position where a fuel injection rate suitable for the idling speed is available, with the point B as the fulcrum.

As the engine speed increases, the flyweights will move outward by the centrifugal force and will shift the shifter by the point A until the shifter compresses the idling spring.

At this time, the fulcrum B will also slightly move toward the tension lever and will move the control rod back in the direction for reducing the fuel injection rate.

As the engine speed decreases, the centrifugal force of the flyweights will decrease and the flyweights will move inward, so the point A will return toward the pump housing. This will set the shifter in the free state, pushing it back toward the pump housing by idling spring force.

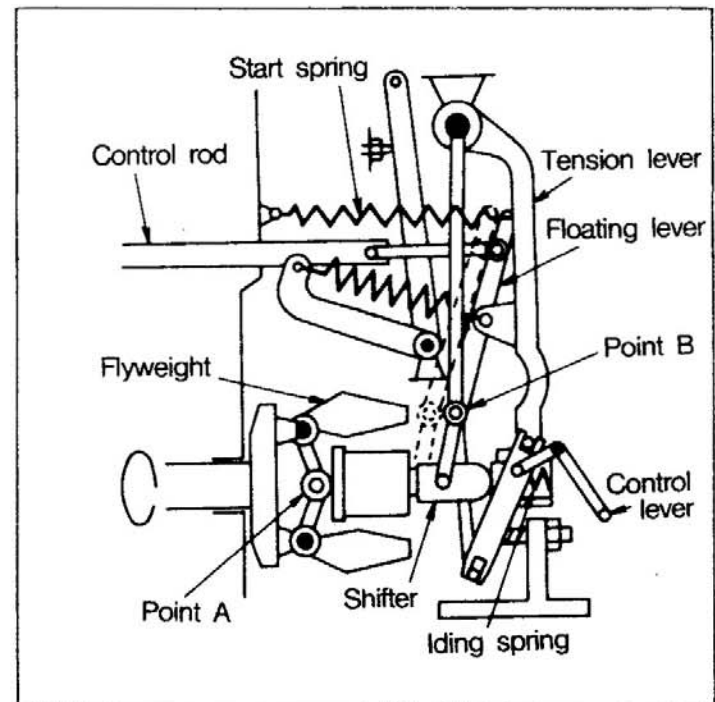

At the same time, the fulcrum B will also slightly move toward the pump housing to push the control rod back in the direction for decreasing the fuel injection rate.

In this manner, the idling speed is maintained stable by slight adjustment of the injection rate.

2) Normal speed operation

If the control lever is moved toward FULL (in the direction of greater fuel delivery), the eccentric shaft coupled to the load control lever will cause the sliding lever to turn with the point D of the tension lever as the fulcrum. In addition, the floating lever will push the control rod back in the direction of greater fuel injection rate, with the point B as the fulcrum.

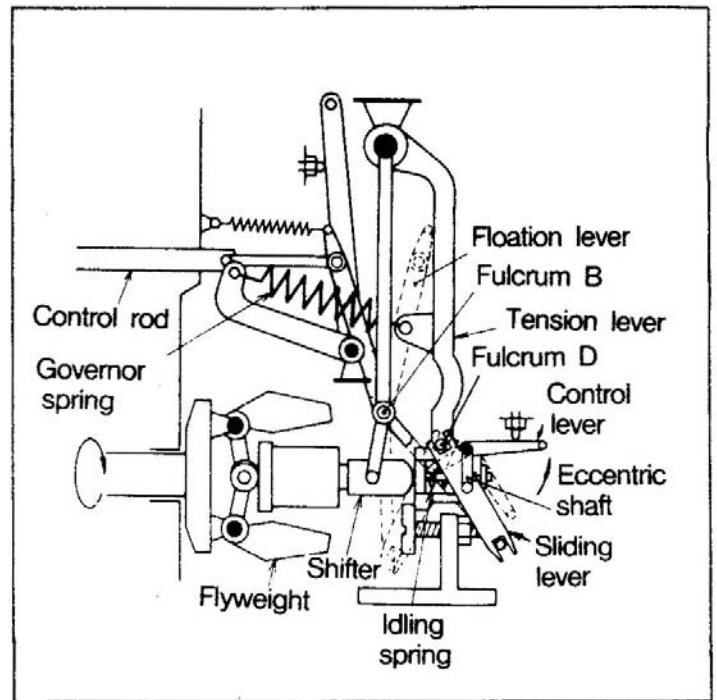

As the engine speed increases, the centrifugal force of the flyweight will increase, and the flyweight will push the shifter. In the normal speed range, however, the shifter will have only a thrust enough for compressing the idling spring and will not be able to push the tension lever out by overcoming the tension of the governor spring.

In this manner, the fuel injection rate is increased or reduced simply by operation of the load control lever which moves the control rod.

3) Control of maximum speed

If the engine speed exceeds a predetermined maximum speed because of changes in engine load, the centrifugal force of the flyweight will overcome the tension of the governor spring and will push the tension lever together with the shifter.

Movement of the shifter will move the point B, and movement of the tension lever will move the point D, and will also move the point C with the point E as the fulcrum.

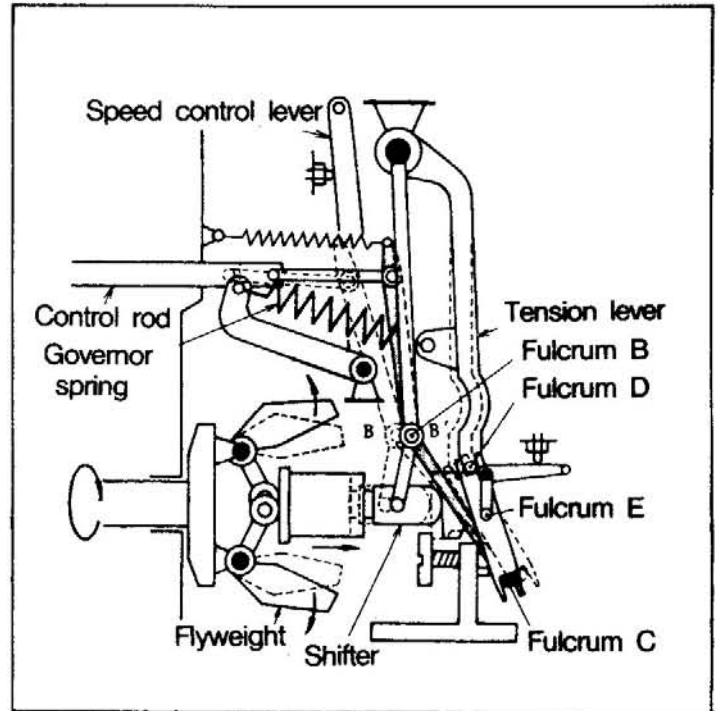

Movement of the point B and movement of the point C will combine to pull the control rod back in the direction of less fuel injection rate, thereby preventing the engine speed from increasing.

If an engine control mechanism which operates the speed control lever adjusting the tension of the governor spring is employed, the governor can be operated as an all-speed governor which maintains a desired engine speed constant.

4) Engine stop

To stop the engine, fuel is cut off by operation the stop lever on the top of the governor.

If the stop lever is operated, the internal lever pushes the pawl of the floating lever link to force the control rod out to the no-injection position.

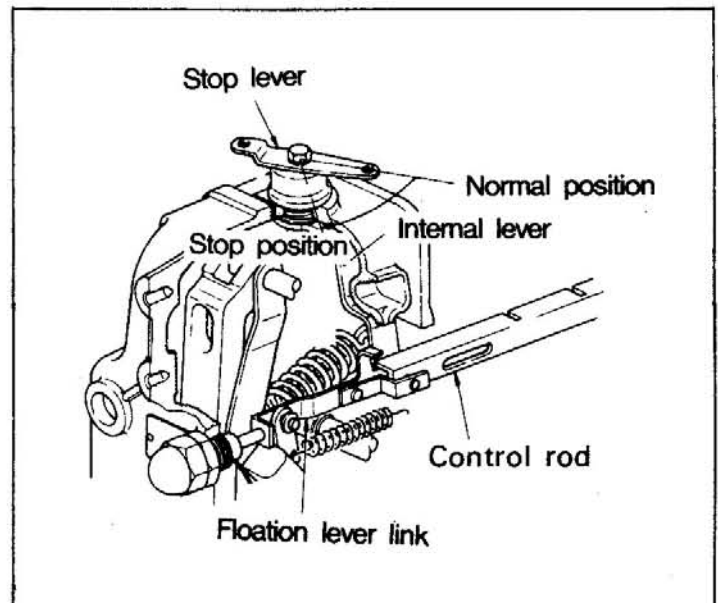

Since the amount the control rod is moved by operation of the stop lever exceeds the operating range of the floating lever mechanism, damage to the link and allied parts is prevented by the cancel mechanism shown.

The floating lever A pushed by the floating lever link turns in such a way as to make the cancel spring bend over the shaft B. So no load is placed on the floating lever C blocked by the idle stopper bolt outside the governor.

Operation of the ungleich device is the same as the RSV type governor.

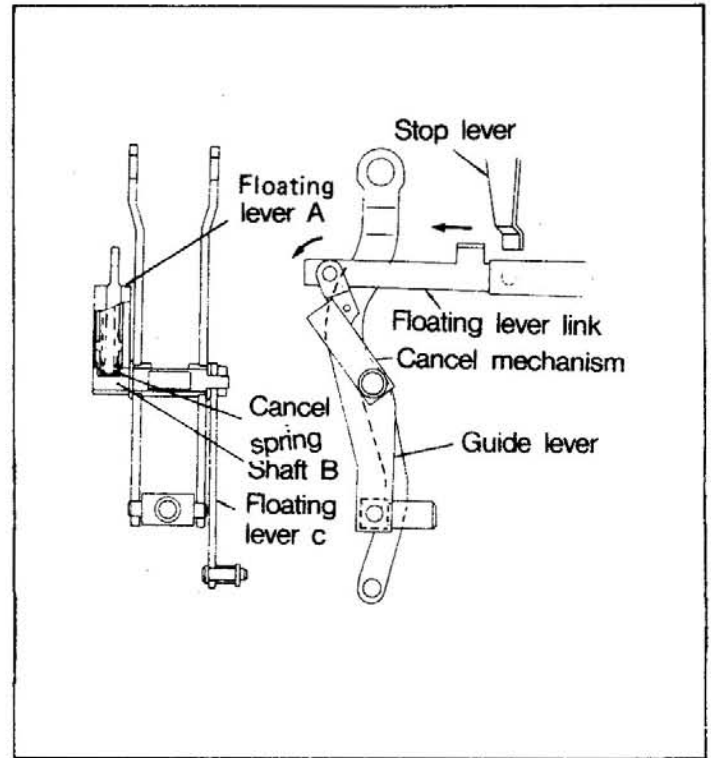

(3) Feed Pump

Supply of fuel to the injection pump proper is accomplished by the feed pump mounted to the side of the injection pump proper and driven by the cam of the injection pump camshaft provided for the purpose.

The priming pump mounted to the feed pump makes it possible to lift fuel manually when the engine is stationary.

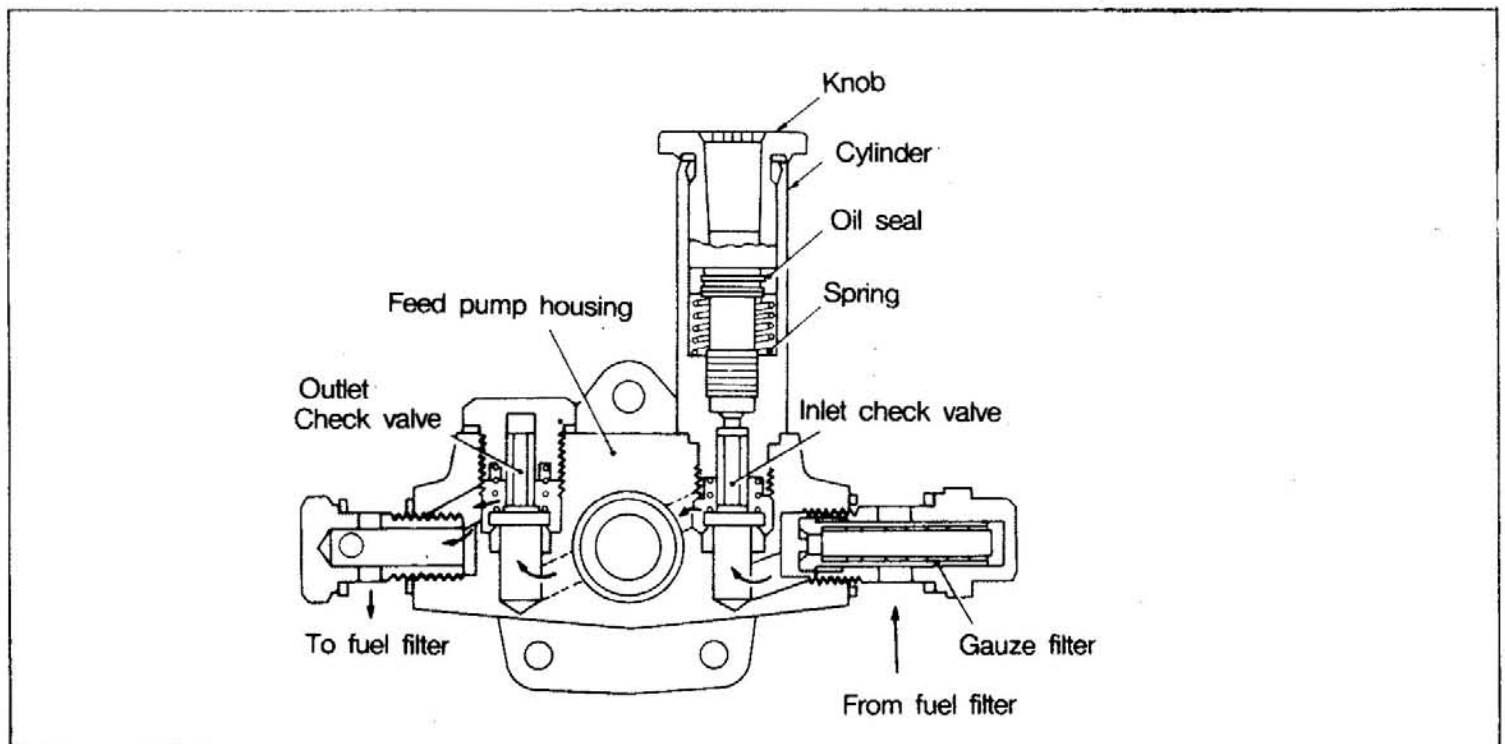

The feed pump feeds fuel under pressure as follows.

When the piston is pushed up by the cam of the camshaft, the fuel in the suction chamber opens the outlet check valve, so most of the fuel is forced out and drawn into the pressure chamber. When the cam is moved away by rotation of the camshaft, the piston is pushed back by the pressure of the piston spring. At the time, the outlet check valve closes and the inlet check valve opens. So fuel is drawn into the suction chamber, whereas the fuel in the pressure chamber is forced out.

When the pressure of the pressure chamber or the delivery pressure exceeds specification, the piston cannot be brought back by the pressure of the piston spring, so the pump action stops and the fuel pressure in the fuel filter does not rise more than necessary.

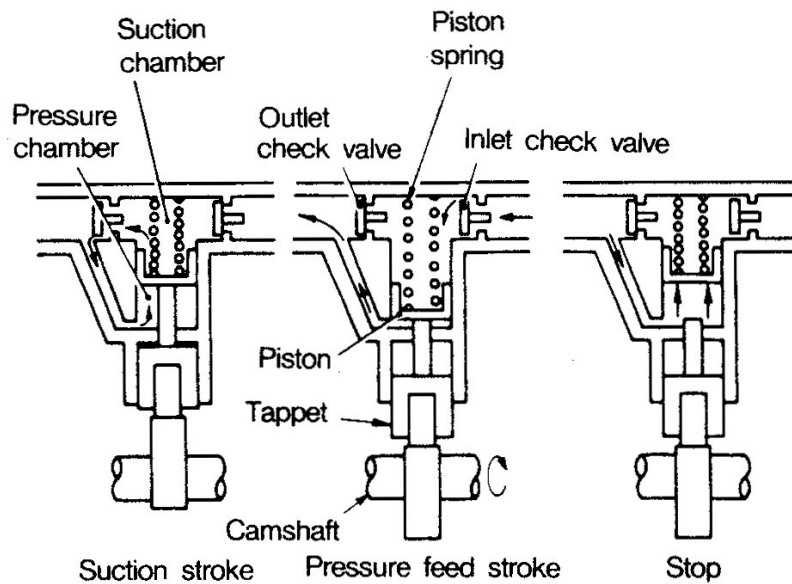

(4) Automatic Timer

The interval between fuel injection into the cylinder and its ignition is called the ignition delay interval. The ignition delay interval is constant regardless of the engine speed. If the ignition timing is always constant, changes in the engine speed will vary the relation between the piston position and ignition timing, making it impossible to obtain the best engine performance. To maintain the relation between the piston position and ignition timing constant at all times, the injection timing must be changed to match the engine speed.

The automatic timer is a device which automatically changes the injection timing according to the engine speed.

(a) SA type automatic timer

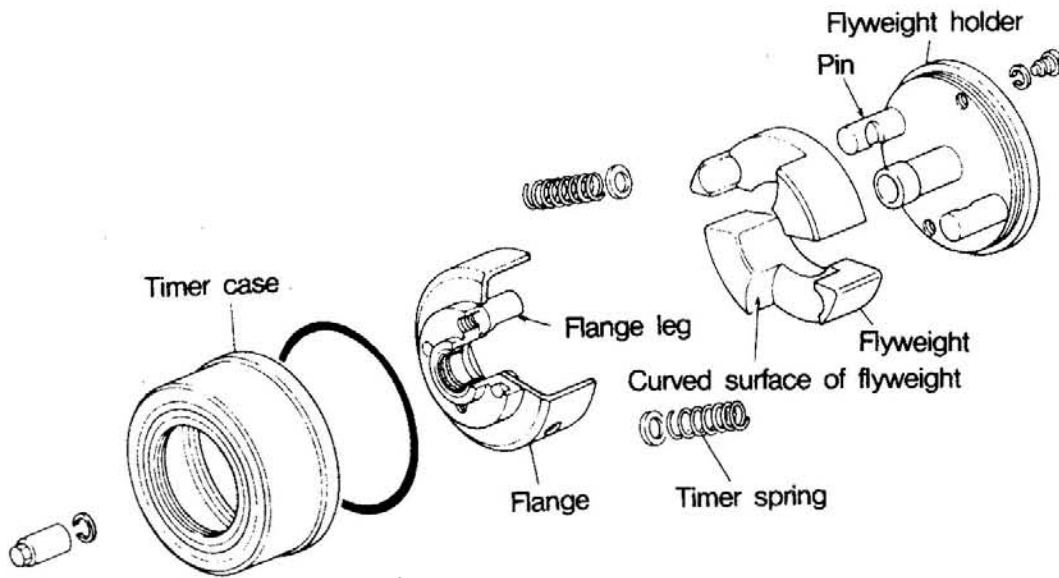

The two flyweights have a hole at one end. The pins of the flyweight holder fit in the holes. The flange legs touch the curved surfaces of the flyweights. Timer springs are mounted to the flyweight pins and flange legs.

Rotation of the engine is transmitted to the flange and from there to the flange legs, flyweights and flyweight holder and to the injection pump camshaft.

During low speed operation of the engine, no centrifugal force acts on the flyweights, so the timer springs have the longest installed length.

When the engine runs at a high speed, a centrifugal force acts on the flyweights and causes them to open outward with the pins of the flyweight holder as the fulcrums. The flange legs are pushed by the curved surfaces of the flyweights in the direction of the timer spring compression, but they cannot be moved because they are coupled to the drive side.

As a result, the pins of the flyweight holder are drawn in the turning direction, while compressing the timer springs, and move the camshaft of the pump in the turning direction to advance the injection timing.

If the engine speed changes from a high to low speed, the centrifugal force of the flyweights will decrease and the flyweights will return to their original positions. At the same time, the pins of the flyweight holder will be pushed back by the timer springs.

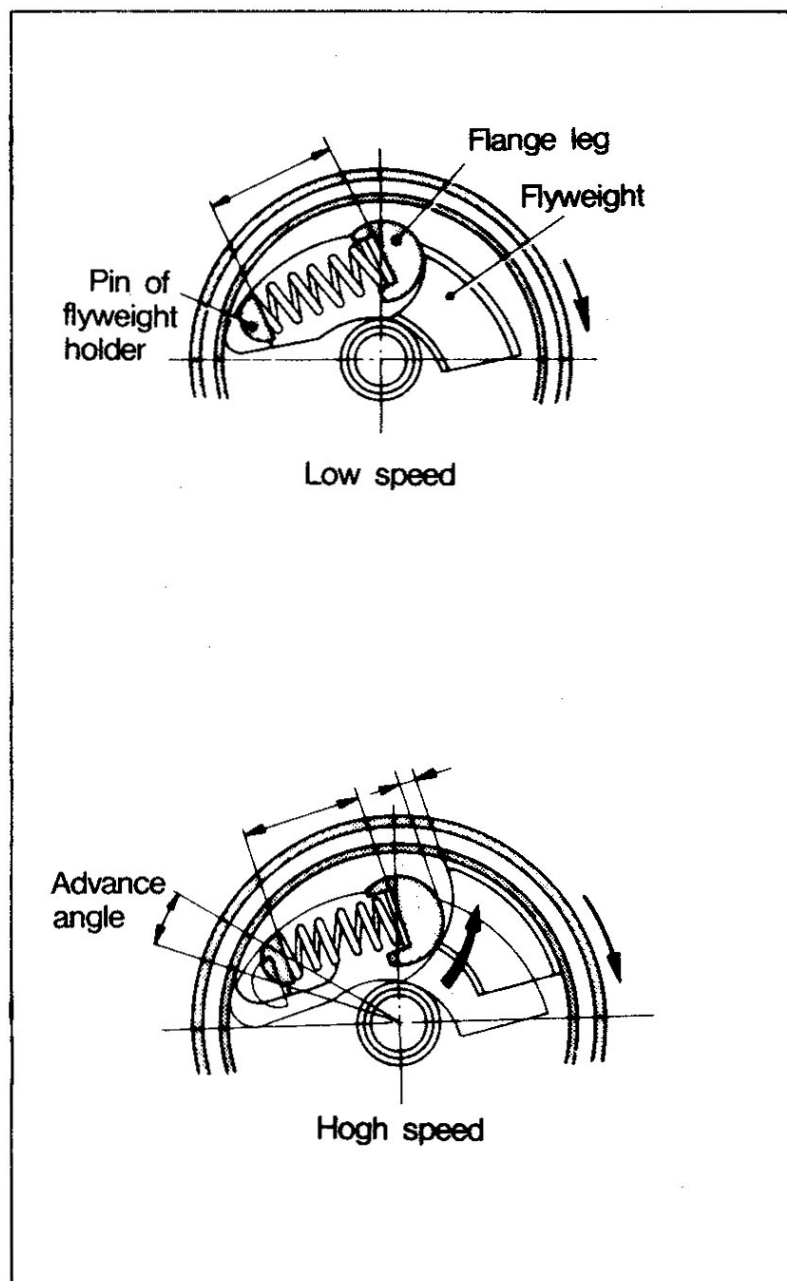

(b) SP type automatic timer

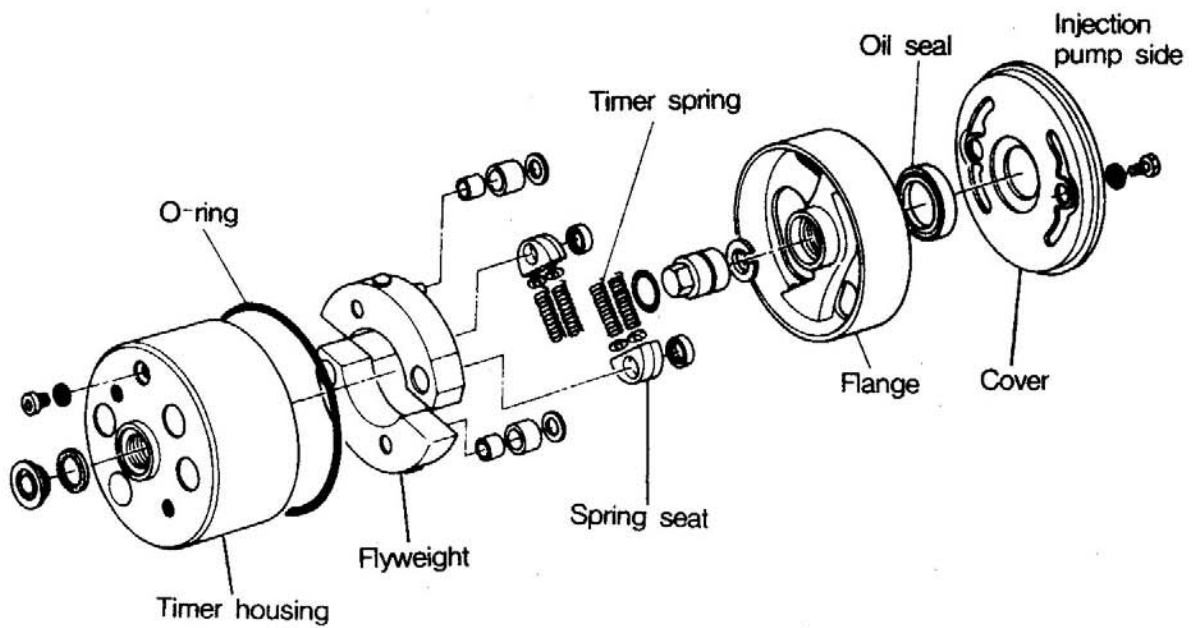

Two flyweights are fitted on the pins of the timer housing and are held in the timer housing. On the other hand, the injection pump connection side flange has a curved surface, and the roller fitted on the pin installed in the flyweight touches the curved surface. Timer springs are held between the spring seats fitted on the timer housing pins which extend through the flange and flyweight. These parts are housed in the timer housing and are totally enclosed with a cover, O-ring and oil seal.

When the engine is running at a low speed, the timer spring pressure is stronger than the centrifugal force of flyweight, so the roller of flyweight is held down by the flange, creating no advance state.

When the engine reaches a high speed, the centrifugal force of flyweight becomes stronger, the roller of flyweight pushes the curved surface of flange with the timer housing pin as the fulcrum, and the flyweight opens outward, while compressing the timer springs.

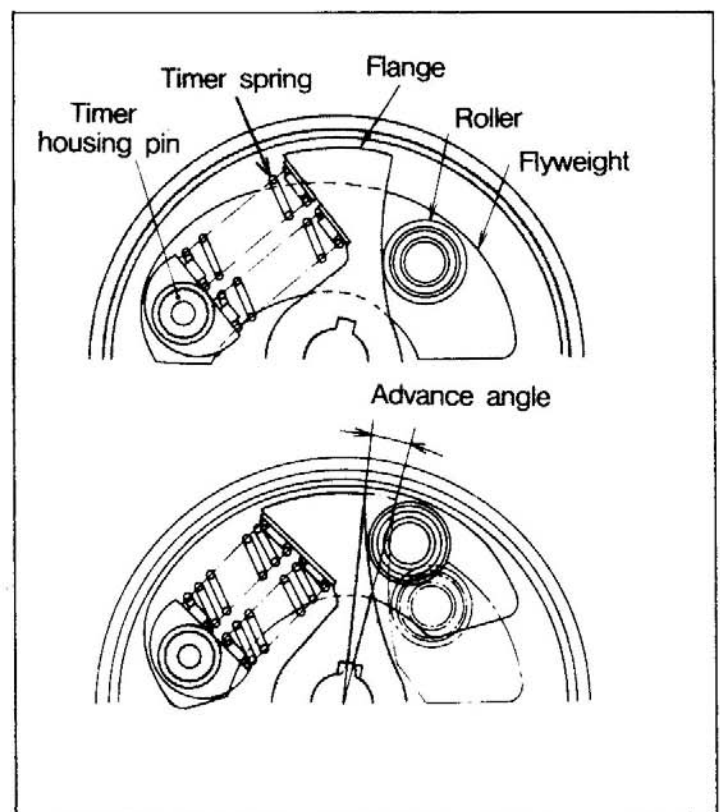

In this manner, the roller installed on the flyweight moves the flange in the turning direction and advances the injection timing.

(5) Coupling

The coupling which transmits drive power from the air compressor crankshaft or injection pump drive crankshaft to the automatic timer is a laminated coupling consisting of thin plates placed one upon another.

The laminated coupling, thanks to the reversibility of the plates, absorbs excess forces other than the torque, thereby providing protection against application of forces other than necessary to the injection pump.

Adjustment of the fuel injection start timing is made by changing the installed condition of the driving coupling.

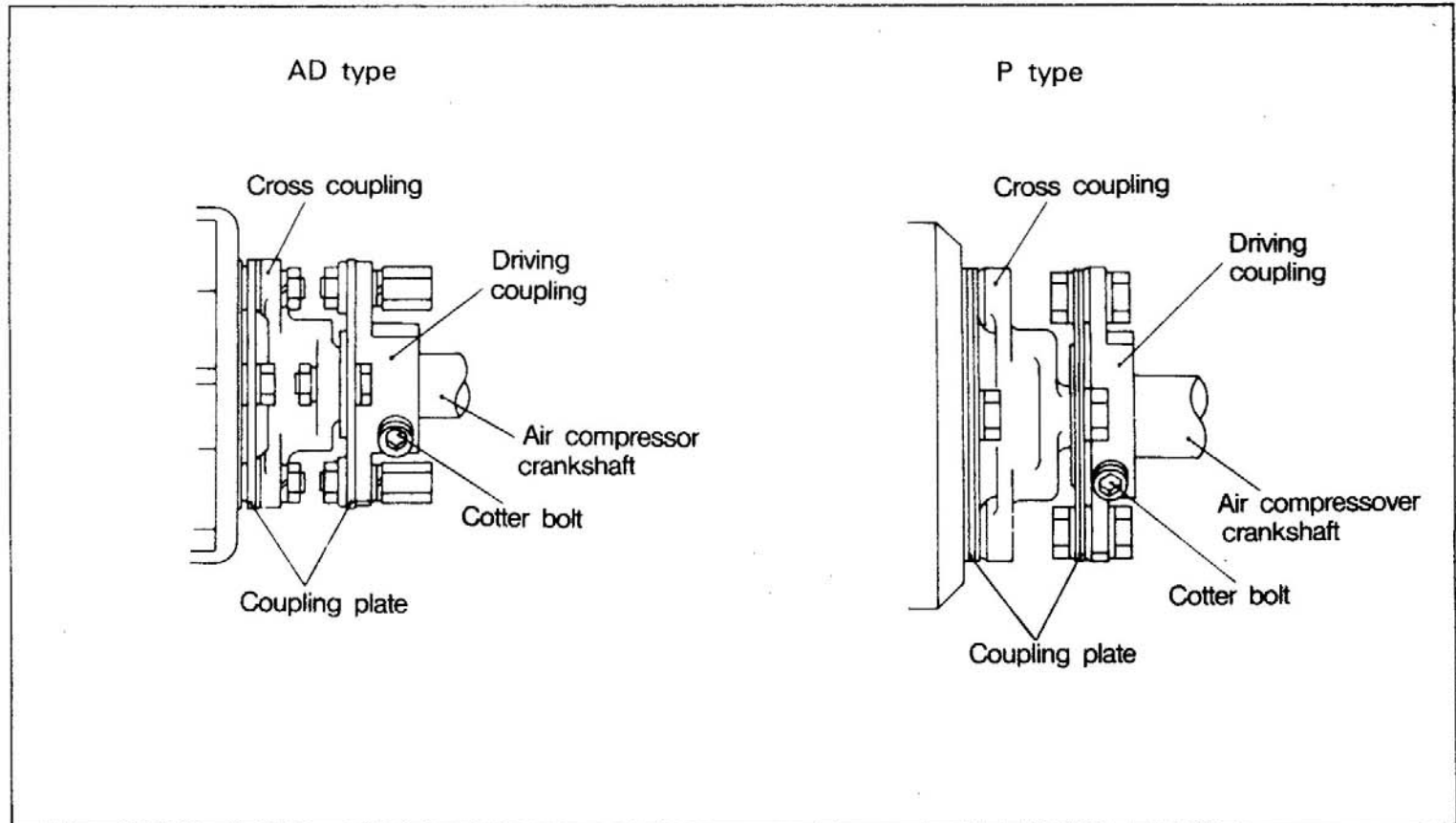

(6) Injection Nozzle

(a) Hole type(1-spring nozzle)

The fuel delivered from the injection pump enters the nozzle holder and has a pressure higher than the specified pressure. So the fuel overcomes the nozzle spring and pushes the needle valve up.

The high pressure fuel which has forced the needle valve up is injected from the orifice at the end of the nozzle into the engine combustion chamber.

Some of the high pressure fuel lubricates the needle valve, etc. and is returned through the fuel leak-off pipe to the fuel tank.

The injection pressure of the injection nozzle is adjusted by changing the tension of the nozzle spring with the adjusting screw.

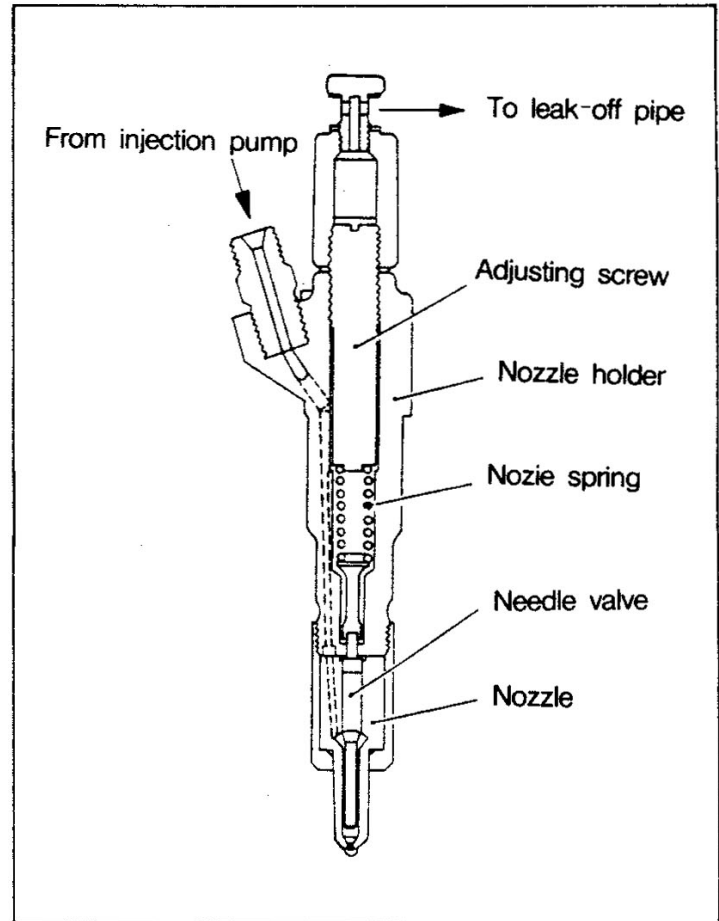

(7) Fuel Filter

The fuel filter is a cartridge type. So the element is easily replaceable.

The fuel filter separates the water contained in the fuel fed under pressure from the feed pump of the injection pump and removes dust and dirt by the element.

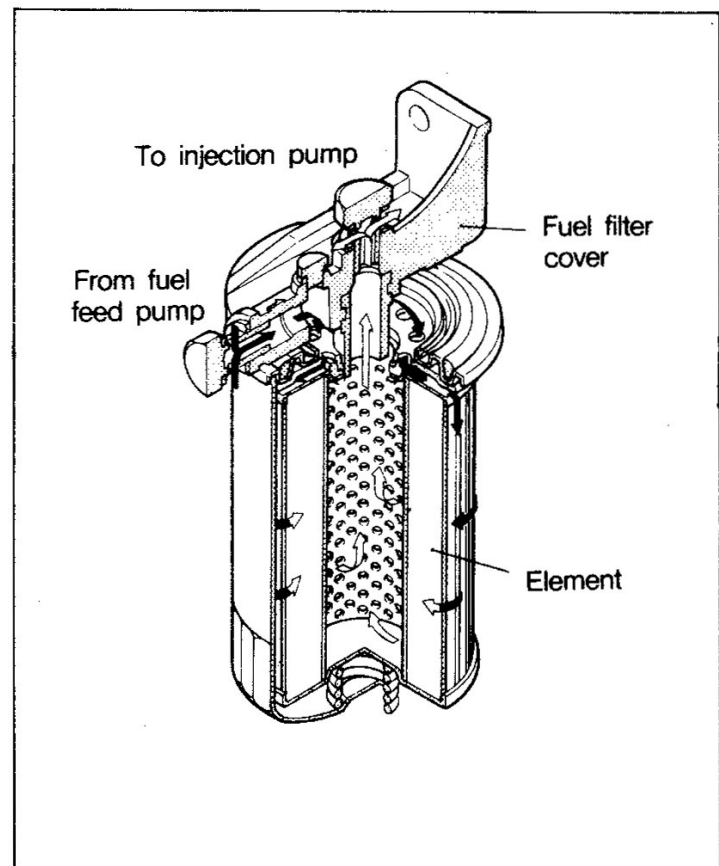

(8) Water Separator (Option)

The sedimenter type water separator separates gas oil and water centrifugally by taking advantage of their difference in specific gravity.

The fuel that has flowed in from the inlet connector is squeezed by the fuel path of the head to increase the flow velocity and spins. The separated water is sedimented in the case, where as the water-separated fuel is drawn through the fuel path in the center of the head into the feed pump.

The water separator sediments not only water but also mud components.

A red float goes up and down with the water level in the semitransparent case, making it possible to visually check the water quantity.

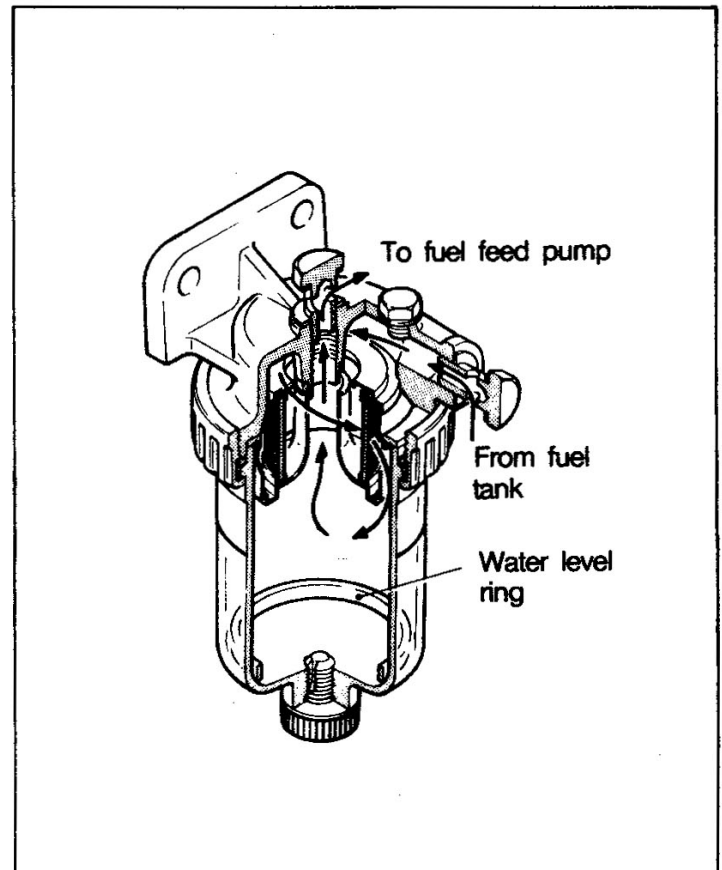

1-3-6 Electrical

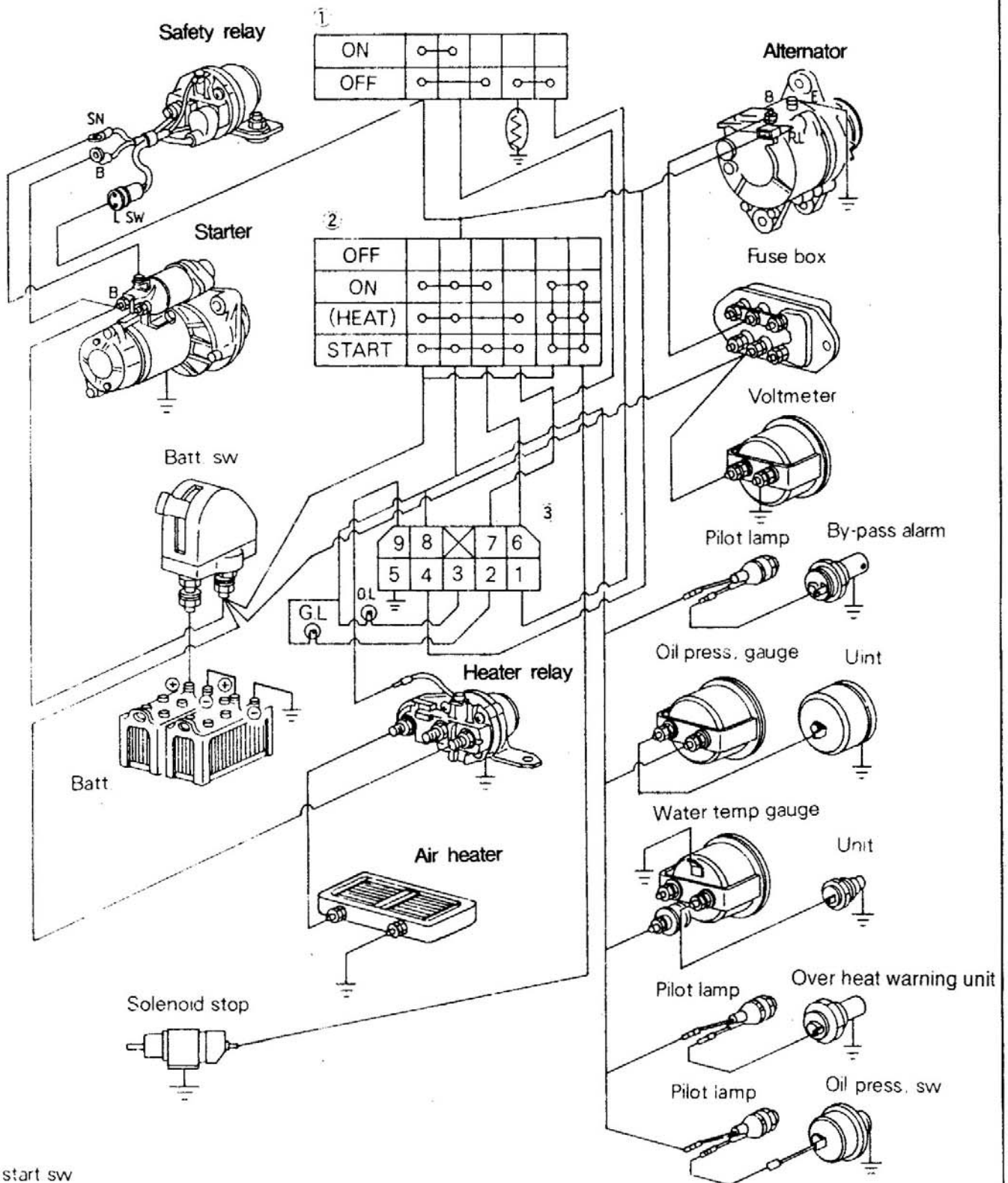

- 1 : Cold start sw
- 2 : Key sw
- 3 : Preheat controller
- G.L : Green lamp
- O.L : Orange lamp

(1) Starter

The starter is a reduction type starter containing a smaller-size and higher-speed motor and a reduction gear mechanism.

The starter may be broadly divided into the motor section which generates power, the overrunning clutch section which transmits the torque of the armature and prevents the starter from overrunning after the engine has started, the magnetic switch section which makes the pinion fit the ring gear and feeds the load current to the motor, and the reduction gear section which reduces the rotating speed of the armature and transmits the torque to the pinion.

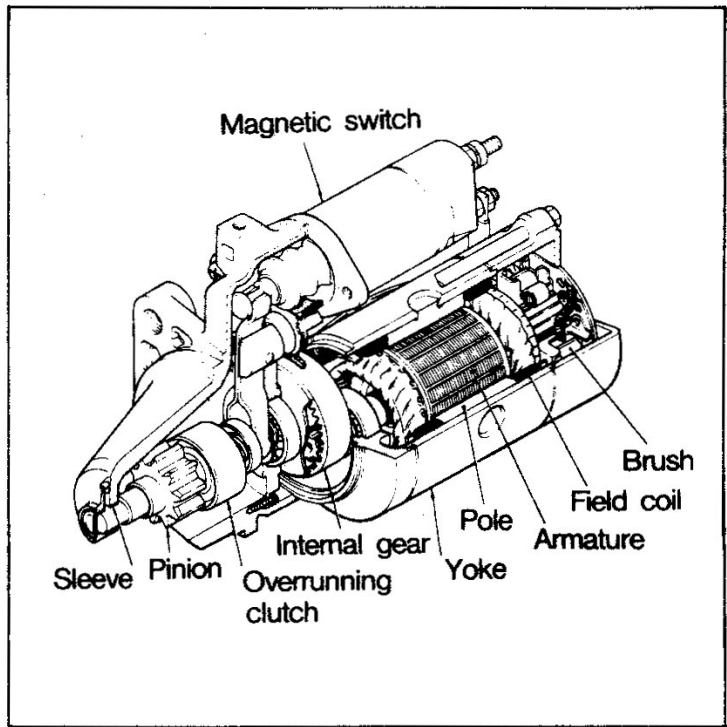

(a) Reduction gear section

The end of the armature is shaped as a gear and is in mesh with the internal gears.

After reduction by the internal gears, the torque is multiplied several times and is transmitted to the pinion.

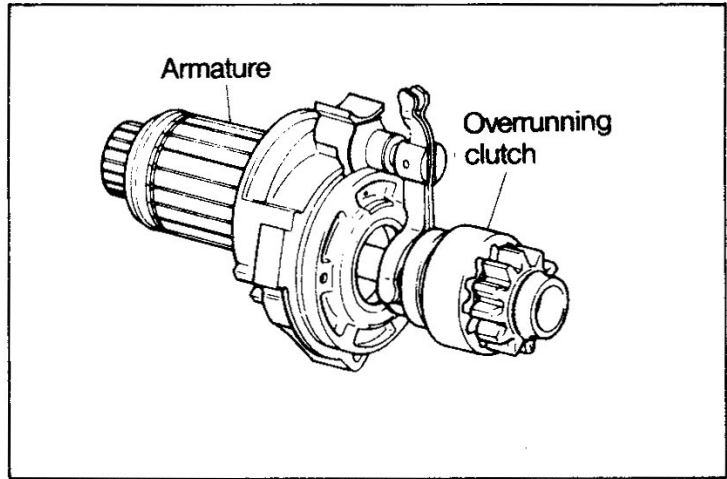

(b) Overrunning clutch

The overrunning clutch is a roller type. Each roller is set in the wedge-like groove provided between the outer and inner races (pinion) and is pressed against the narrower side of the groove by spring.

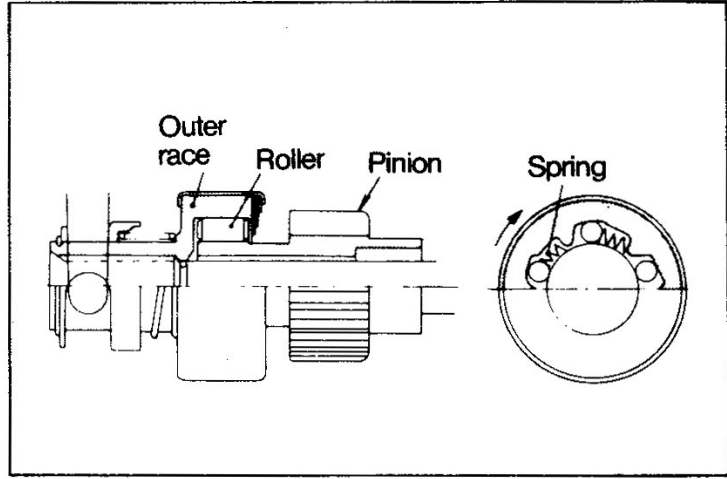

When the armature turns, the rotation is transmitted through the rollers to the pinion by the wedge action of the outer race of the clutch.

On the other hand, no torque is transmitted from the pinion side as the wedge action is released.

(c) Operation

While the starter switch is ON, current flows from the terminal "SW" of the starter relay to the terminal "L" and closes the contact "P₂".

When the contact "P₂" closes, current from the battery flows from the terminal "S" of the magnetic switch to the pull-in coil "P" and holding coil "H".

Furthermore, the current that has decreased flows from the terminal "M" to the motor section.

The plunger, attracted by the magnetic flux of the pull-in coil and holding coil, closes the contact "P₁" and simultaneously pushes out the pinion turning slowly on weak current.

When the pinion comes into complete mesh with the ring gear, the contact "P₁" closes and the large current of the battery directly flows to the motor section to turn the pinion powerfully.

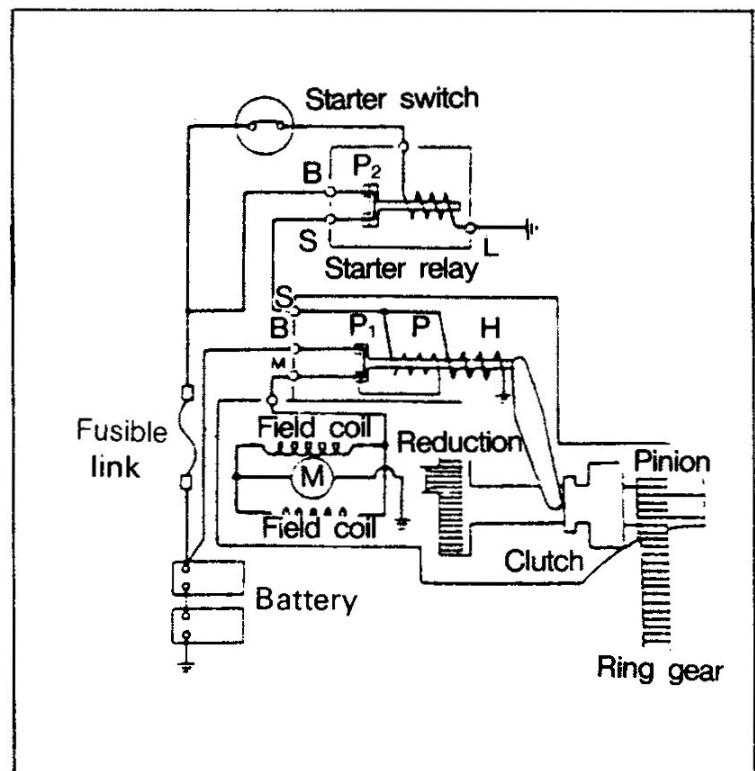
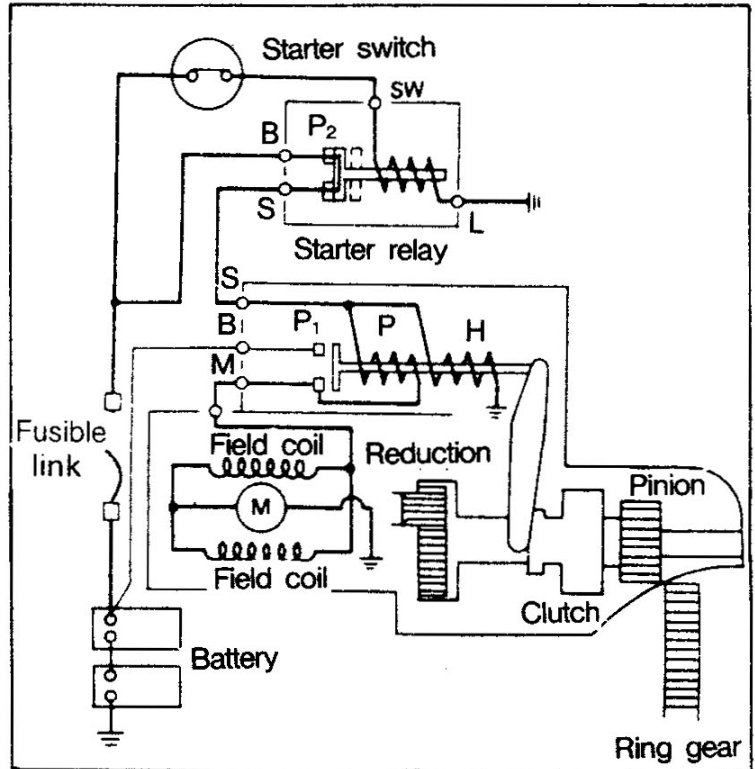
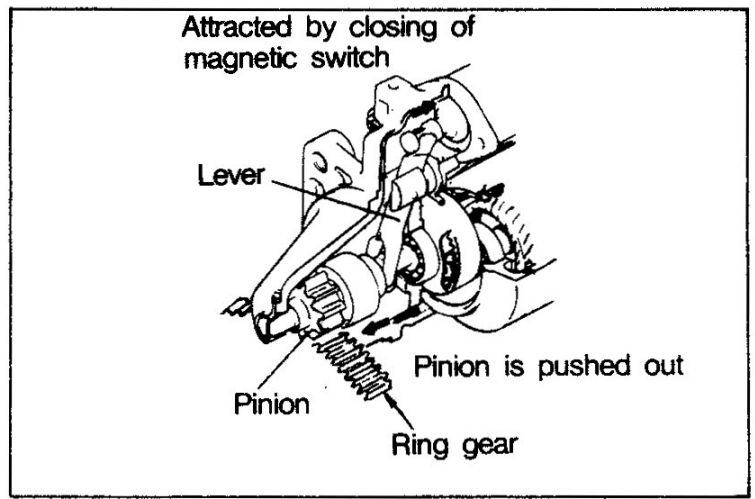

In this condition, no current flows to the pull-in coil.

The plunger is retained by the holding coil alone.

When the starter switch is set to OFF, the contact point P_2 opens.

The moment the starter switch is opened, the P_1 is still in closed position and the battery current flows from the B terminal to the pull-in coil (P) and holding coil (H).

Since the direction of current that flows is reverse, the magnetic fluxes cancel each other, and the return spring pushes the plunger back to its original position. At the same time, the contact point P_1 opens, so the current to the motor section is cut off.

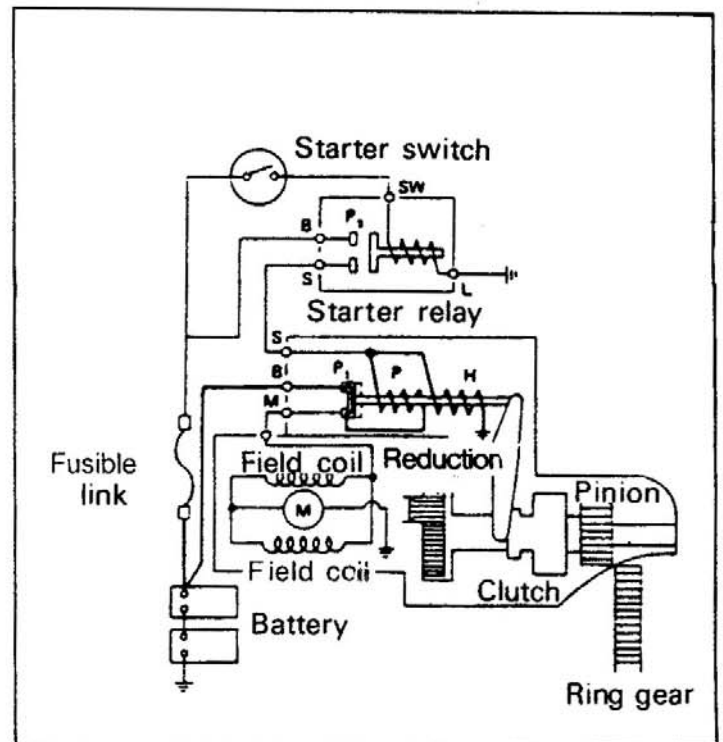

(2) Alternator

(a) 40A IC regulator built-in alternator

The 40A alternator is a compact IC regulator built-in alternator (abbreviated to built-in alternator) consisting of an IC regulator built in the alternator rear bracket.

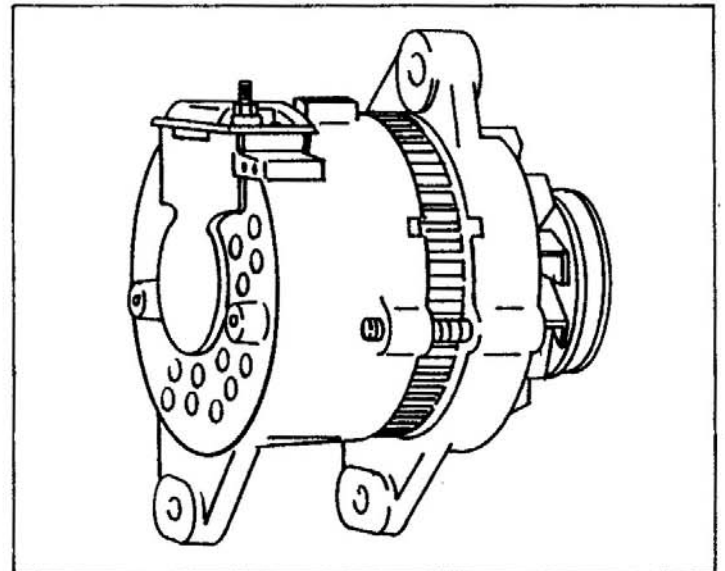

The built-in alternator offers the following features.

1. The residual magnetism of the rotor allows the alternator voltage to build up through self-excitation.
2. Field current directly flows from the diode trio to the field coil. So no voltage drop is caused by the starter switch and wiring as in the conventional alternator.

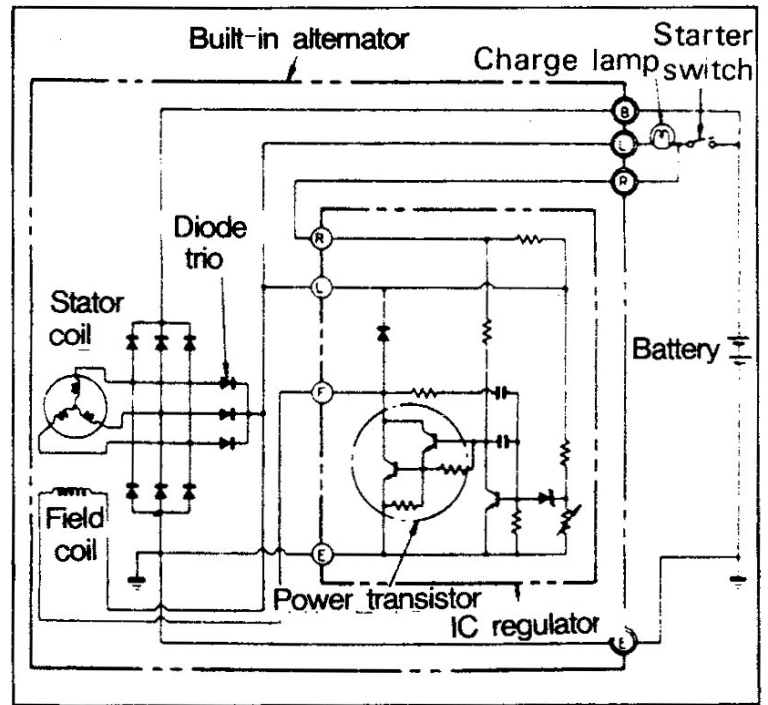

3. To make sure that the voltage builds up easily, power transistor base current is kept flowing. Therefore, when the battery switch is in closed position, current (10 mA or less) continues to flow through the regulator even when the engine is stationary.

When the battery switch is closed, current flows to the base of the power transistor and causes the power transistor to be ON.

When the alternator is turned, the residual magnetism of the rotor causes the stator coil to generate a very small voltage, and current flows from the diode trio to the field coil to excite the rotor.

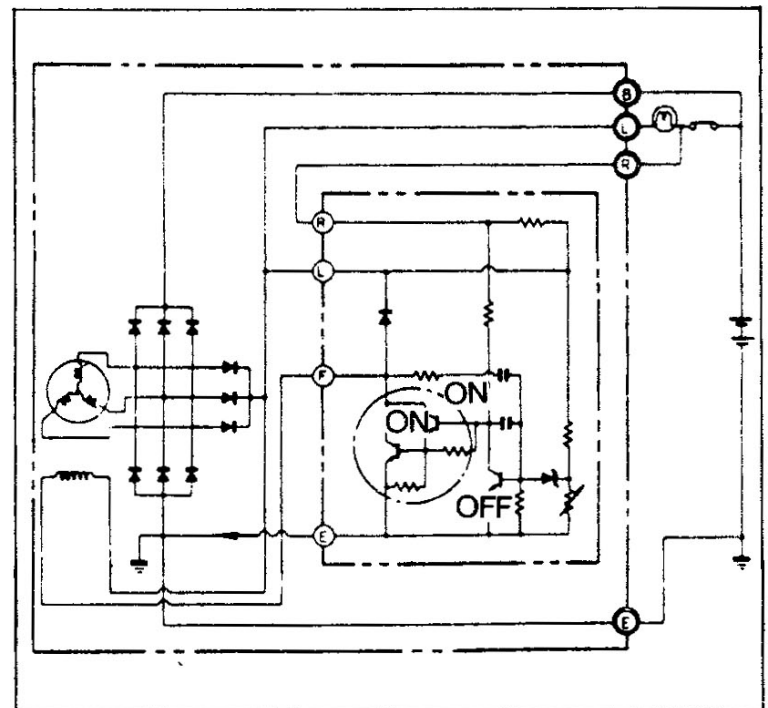

If the engine is started and the rotor excited, the stator coil generated voltage suddenly rises.

Current to the base of the power transistor is supplied from the alternator itself.

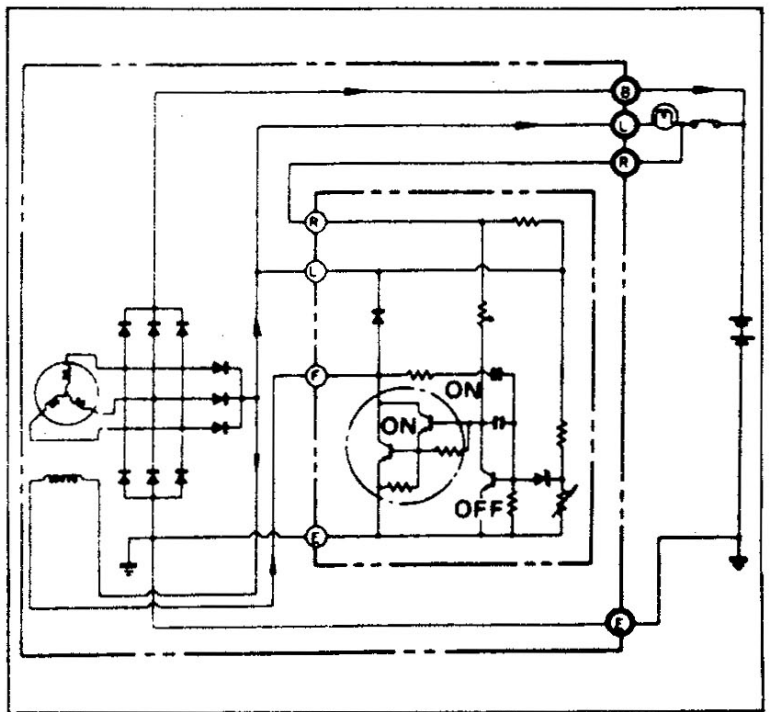

When the voltage generated by the alternator increases, the Zener diode "Dz" conducts, base current of the transistor "Tr₁" flows and causes "Tr₁" to be ON.

So current to the power transistor is short-circuited to "Tr₁", and the power transistor through which base current has ceased to flow is forced to the OFF state. As the result, no current flows to the field coil, and the voltage generated by the alternator falls.

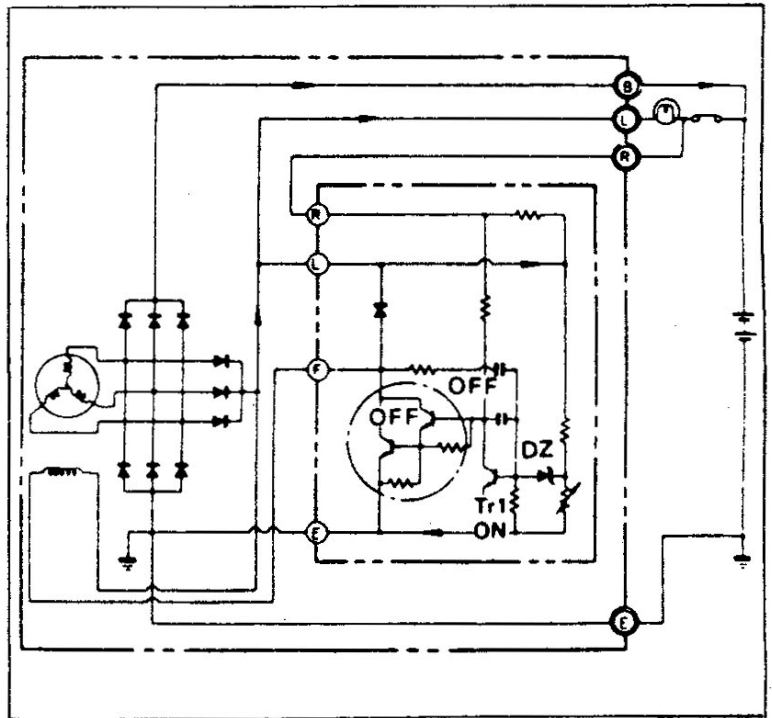

When the generated voltage falls too far below the Zener voltage, "Dz" does not conduct so that "Tr₁" is forced to the OFF state.

Accordingly, base current flows again to the power transistor and causes the power transistor to be ON, so that current flows to the field coil and the voltage generated by the alternator rises.

The voltage generated by the alternator is adjusted through repetition of such operations by the IC regulator.

(3) Intake Air Heater

The intake air heater improves engine startability by heating intake air at engine starting.

When the starter switch is set to "HEAT" or "START" position, current is supplied to the intake air heater. If current is supplied for about 40 to 60 seconds with the starter switch at the "HEAT" position, the temperature of the intake air heater exceeds 800°C, and the air heater indicator indicating heated condition for the driver becomes red hot.

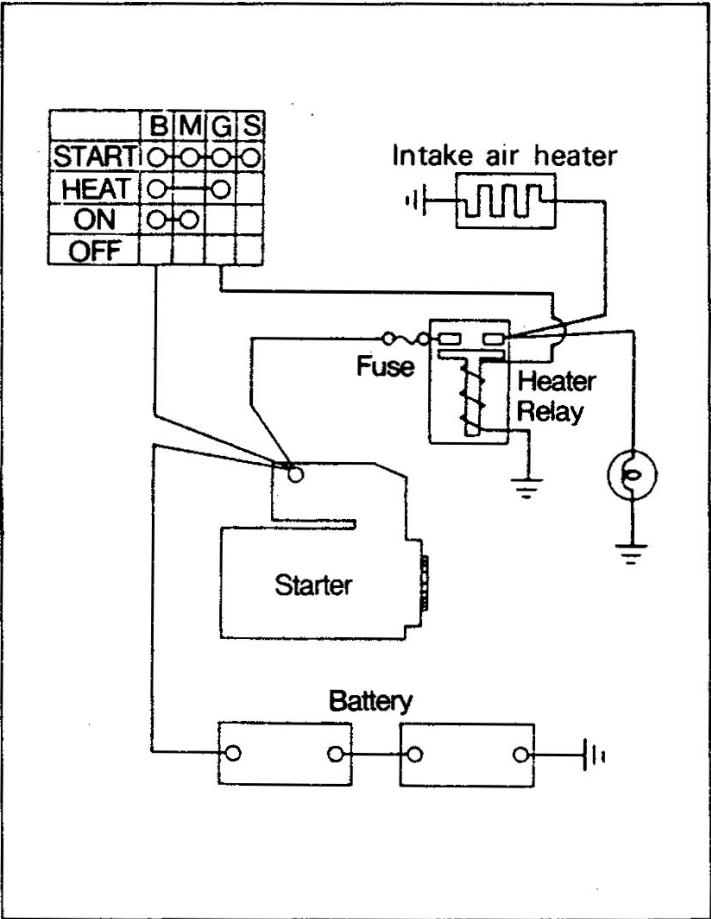

1-3-7 Other Equipment

(1) Injection pump Drive

The injection pump drive is mounted to the flywheel housing on the left side of the engine and is driven at half the engine speed by the timing gear train (injection pump gears) of the engine. A coupling is mounted at the rear end of the injection pump drive crankshaft to drive the injection pump.

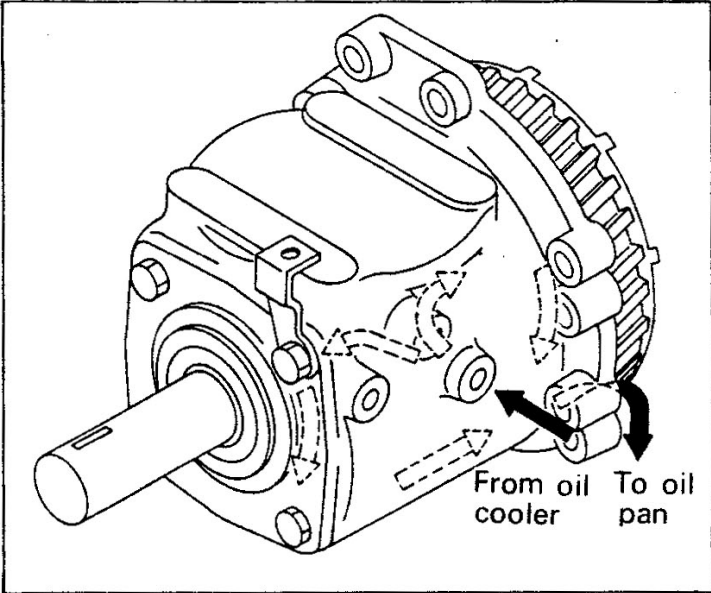

For lubrication of the parts, the engine oil is drawn by an oil pipe from the engine oil cooler. The oil flows through the oil hole in the shaft and lubricates the bearing.

Excess oil flows from the bottom hole in the crankcase and returns through the timing gear train to the oil pan.

2-1 ENGINE ADJUSTMENT STANDARDS

Adjustment Item		Adjustment Standard Value	
Valve timing	Inlet valve opened	18° BTDC	
	Inlet valve closed	50° ABDC	
	Exhaust valve opened	50° BBDC	
	Exhaust valve closed	18° ATDC	
Valve clearance (when cold)	Inlet side	0.4 mm	
	Exhaust side	0.6 mm	
Fuel injection timing		Vary on different specifications.	
No-load minimum speed(idling)			
No-load maximum speed			
Tension of V-belt(deflection of V-belt when pressed down at middle under approx. 98N or 10 kgf pressure)		10 to 15 mm	
Compression pressure (With engine at 200rpm)	Standard value	2 750 kpa(28 kgf/cm ²)	
	Repair limit	1 960 kPa(20 kgf/cm ²)	
	Difference between cylinders	390kPa(4 kgf/cm ²) or less	
Oil pressure (oil temperature : 70°C)	Air idling speed	Standard value	145 to 290 kPa (1.5 to 3.0 kgf/cm ²)
		Repair limit	49kPa (0.5kgf/cm ²)
	At maximum speed	Standard value	290 to 490 kPa
		Repair limit	195kPa(2.0kgf/cm ²)

2-2 SERVICE STANDARDS

2-2-1 Engine Proper

All values in mm unless otherwise specified.

Description		Nominal value (Basic diameter)	Repair limit	Service limit	Correction and remarks
Clearance between rocker and rocker shaft		[28] 0.03 to 0.08	0.2		Replace bushing.
Outer valve spring	Free length	89.38		85	Replace.
	Installed load (installed length : 58.35)	450N(46.1kgf)		380N (39kgf)	
	Squareness			2.5	
Inner valve spring	Free length	65.04		62.0	Replace.
	Installed load (installed length : 50.35)	115 N (12 kgf)		100N (10.2kgf)	
	Squareness			2.5	
Clearance between crankcase tappet hole and tappet		[35] 0.06 to 0.10		0.2	Replace tappet.
Push rod runout				0.6	Replace.
Cylinder head bottom surface distortion		0.07 or less	0.08		May be ground to cylinder head height of 129.8 mm maximum
Valve stem O.D.	Inlet	11.95 to 11.96		11.85	Replace.
	Exhaust	11.91 to 11.93			
Clearance between valve stem and valve guide	Inlet	[12] 0.05 to 0.09		0.2	Replace valve guide.
	Exhaust	[12] 0.09 to 0.12			
Depth of valve from cylinder head bottom surface	Inlet	0.25 to 0.75		1.0	Replace valve seat insert. Service limit shows value when new valve is instal- led. (Minus value shows amount of projec- tion.)
	Exhaust	-0.05 to 0.45		0.7	
Valve seat angle		45°			

Description		Nominal value (Basic diameter)	Repair limit	Service limit	Correction and remarks
Valve margin	Inlet	2.2		1.7	Replace.
	Exhaust	2.5		2.0	
Valve seat insert seat width		2.69 to 2.96	3.5		
Eccentricity of flywheel housing			0.2		Correct installed condition.
Flywheel	Runout		0.2		Correct installed condition
	Friction surface distortion	0.1 or less	0.2		Correct.
	Depth from clutch cover mounting surface to friction surface	48		49.5	Replace.
Timing gear backlash	Between crankshaft gear and idler gear "B"	0.12 to 0.26		0.4	Replace.
	Between idler gear "A" and camshaft gear	0.11 to 0.23		0.4	
	Between idler gear "A" and idler gear "C"	0.11 to 0.24		0.4	
	Between injection pump gear and idler gear "C"	0.12 to 0.25		0.4	
	Between power steering gear and idler gear "C"	0.10 to 0.23		0.4	
End play of idler gear		0.1 to 0.28	0.4		Replace thrust plate.
Clearance between idler shaft and idler gear bushing		{40} 0.03 to 0.06	0.2		Replace bushing.
Camshaft gear end play		0.05 to 0.22	0.4		Replace thrust plate.
Clearance between camshaft journal and camshaft bushing	No.1 journal	{65} 0.03 to 0.08	0.25		Replace bushing
	No. 2 journal	{65.25} 0.03 to 0.08			
	No. 3 journal	{65.50}			
	No. 4 journal	0.03 to 0.08			

Description		Nominal value (Basic diameter)	Repair limit	Service limit	Correction and remarks
	No. 5 journal	{65.75}	0.25		Replace bushing
	No. 6 journal	0.03 to 0.08			
	No. 7 journal	{66} 0.03 to 0.08			
Cam profile(difference between lobe height and base circle diameter)				8.3	Inlet Lobe height : 56.167 Base circle diameter : 47.334 Exhaust Lobe height : 56. 036 Base circle diameter : 47.216
Camshaft bend		0.05 or less	0.08		Correct or replace.
Crankcase top surface distortion		0.07 or less	0.2		Regrind very slightly.
Cylinder liner	I.D.	130.014 to 130.054	130.25		Replace or correct to oversize.
	Cylindricity (diametral method)	0.02 or less	0.3		
	Projection of flanged portion	0 to 0.08			Replace.
Clearance between piston and cylinder liner(selection fit)		{130} 0.178 to 0.204			
Clearance between piston ring groove and piston ring	1st ring	0.11~0.13		0.25	Replace.
	2nd ring	0.05 to 0.08		0.15	
	Oil ring	0.03 to 0.06		0.15	
Clearance between open ends of piston ring		0.4 to 0.6		1.5	Replace.
Projection of piston from top surface of crankcase		0.87 to 1.33			Replace parts.
Clearance between piston pin hole and piston pin		{50} 0.01 to 0.02		0.1	Replace.

Description		Nominal value (Basic diameter)	Repair limit	Service limit	Correction and remarks
Connecting rod	Clearance between con- necting rod bushing and piston pin	[50] 0.02 to 0.05	0.1		Replace bushing.
	Bend and torsion	[50] 0.02~0.05	0.05 or less		Correct or replace.
	End play	0.2 to 0.5		1.0	Replace.
Connecting rod bearing	Oil clearance	[84] 0.07 to 0.13	0.25		Replace.
	Tension when free			Less than 90.5	
Crankshaft	End play	0.09 to 0.23	0.4		Adjust by oversize thrust plate.
	Bend	0.04 or less	0.1		Correct or replace.
	Out-of-round- ness of journal and pin	0.01 or less	0.08		Grind and correct to undersize.
	Cylindricity of journal and pin	0.006 or less			
Main bearing	Oil clearance	[100] 0.08 to 0.15	0.25		Replace.
	Tension when free			Less than 106.5	

2-2-2 Inlet and Exhaust

All values in mm unless otherwise specified.

Description		Nominal value (Basic diameter)	Repair limit	Service limit	Correction and remarks
Turbo- charger (3LM)	I.D. of bearing inserting portion of bearing housing			19.06	Replace.
	Turbine wheel shaft journal diameter			11.18	Replace.
	Turbine wheel shaft journal diameter			0.015	Replace.
	Piston ring open end clearance	0.015 to 0.18			Replace insert.
	Clearance between turbine wheel and turbine housing	0.53 to 1.04			Check.
	End play of turbine wheel shaft	0.05 to 0.13			Check.
	Clearance between turbine back plate and turbine wheel back surface	0.74 to 1.55			Check.
Dust indicator operating resistance value		700± 50 mmAg (7.47 ±0.57kpa)			Replace.

2-2-3 Lubrication

All values in mm unless otherwise specified.

Description		Nominal value (Basic diameter)	Repair limit	Service limit	Correction and remarks
Oil pump	Backlash between crankshaft gear and oil pump idler gear	0.13 to 0.24		0.4	If backlash is less than 0.13, adjust shims.
	Backlash between idler gear and oil pump gear	0.11 to 0.22		0.4	Replace.
	Difference between pump case depth and gear height	0.05 to 0.11		0.15	Replace.

Description		Nominal value (Basic diameter)	Repair limit	Service limit	Correction and remarks
Oil pump	Clearance between gear tooth end and pump case	0.11 to 0.18		0.2	Replace.
	Clearance between drive gear shaft and case and cover	{20} 0.04 to 0.07		0.15	Replace.
	Clearance between driven gear shaft and driven gear	{20} 0.04 to 0.07		0.15	Replace.
	Clearance between idler gear shaft and idler gear	{22} 0.03 to 0.05		0.15	Replace bushing.
Relief valve	Valve opening pressure	1 180kPa (12kgf/m ²)			Replace.
	Spring load (Installed length : 46 : 3)	158± 7.8N (16.1± 0.8kgf)			
Oil bypass alarm valve opening pressure (ON start pressure)		295 to 345 kPa (3 to 3.5kgf/m ²)			
Oil cooler bypass valve opening pressure		175 to 215 kPa (1.8 to 2.2kgf/m ²)			
Regulator valve	Valve opening pressure	360 to 420 kPa (3.7 to 4.3kgf/m ²)			Replace.
	Spring load (Installed length : 50)	76~80N (7.8~8.2kgf)			

2-2-4 Cooling

All values in mm unless otherwise specified.

Description		Nominal value [Basic diameter]	Repair limit	Service limit	Correction and remarks
Thermostat	Valve Opening start temperature	69 to 73 °C			Replace.
	Valve lift/temperature	10mm or more/ 85°C			
Water pump	Interference between pump shaft and pulley	0.05 to 0.08		Reassembly tolerated up to two times	Replace.
	Interference between pump shaft and impeller	0.04 to 0.06			

2-2-5 Fuel

All values in mm unless otherwise specified.

Description		Nominal value [Basic diameter]	Repair limit	Service limit	Correction and remarks	
Injec- tion pump proper	Injection spacing	60° ±30'			Adjust.	
	Prestroke	AD type	4.5			Adjust.
		P type	4.8			
	Overall tappet clearance	AD type			0.3	Replace.
		P type			0.2	
	Clearance between tappet and housing	AD type	26] 0.03 to 0.07		0.2	Replace.
		P type			0.15	
	Clearance between plunger driving face and control sleeve	AD type	0.03 to 0.08		0.12	Replace.
Wear of plunger contacting surface of lower spring seat	P type			0.2	Replace.	

Description		Nominal value (Basic diameter)	Repair limit	Service limit	Correction and remarks
Injection pump proper	End play of camshaft		0.02 to 0.06		Adjust shims.
	Sliding resistance of control rack (when stationary)	AD type	1.5N or less (150 gf or less)		Check.
	Sliding resistance of control rod (when stationary)	P type	1.3N or less (130 gf or less)		Check.
	Tappet clearance	AD type	0.3 or more		Adjust.
	Backlash between control rack and pinion	AD type	0.15	0.3	Replace.
	Overflow valve opening pressure	AD type	157 kPa (1.6 kgf/cm ²)		Replace.
AD type, P type		255 kPa (2.6kgf/cm ²)			
Governor	Dimension from governor housing to shifter	RSV type	19 to 19.2		Adjust shims.
		RFD type	33 to 33.4		
Feed pump	Overall tappet clearance			0.2	Replace.
	Lifting capacity	Number of strokes pump goes through before lifting of fuel when operated at 60 to 100 strokes a minute	25 strokes or less		
	Air tightness	When 196 kPa (2kgf/cm ²) air pressure is applied	Occ(No leaks tolerated)		
	Delivery rate	For 15 seconds at 1000 rpm	AD type	350cc	
P type			530cc		
Injection nozzle injection pres- sure	1-spring nozzle		21.6 to 22.5 kPa (220 to 230 kgf/cm ²)		Adjust or replace.
	2-spring nozzle		17.2~18.1 kPa (175~185 kgf/cm ²)		

2-2-6 Electrical

(1) Starter

All values in mm unless otherwise specified.

Description		Nominal value (Basic diameter)	Repair limit	Service limit	Correction and remarks
Commutator O.D.		38.7		37.7	Replace.
Commutator periphery runout		0 to 0.03	0.1		Replace or correct.
Depth of groove between segmets		0.7 to 0.9	0.3		Correct.
Brush length		17		11	Replace.
Brush spring pressure		25 to 33N (2.55 to 3.45kgf)		18N(1.8kgf)	Replace.
Pinion gap		0.1 to 2.0			Adjust washers.
Gear shaft thrust gap		0.1 to 0.5			Adjust washers.
No-load-character- istics	Voltage	23V			Check.
	Current	110A or less			
	Rotating speed	3 100 rpm or more			
Magnet switch operating voltage		16V or less			Check.
Starter relay coil resistance		10.4Ω			Replace.

(2) Alternator

All values in mm unless otherwise specified.

Description		Nominal value (Basic diameter)	Repair limit	Service limit	Correction and remarks
Slip ring portion O.D.		41		40.4	Replace.
Brush spring pressure		3.7N(380gf)		2N (200gf)	Replace.
Brush length		23		8	Replace.
Field coil resistance(at 20°C)		10Ω			
Load character- istics	Rotating speed (1500 rpm)	Terminal voltage	27V		Check.
		Cur- rent	when cold	26A or more	
	When hot		22A or more		
	Rotating speed 2500 rpm	Terminal voltage	27V		
Cur- rent		When cold	37A or more		
	When hot	33A or more			
IC regulator regulated voltage (5000rpm, 5A or less)		28 to 29V			Replace.

(3) Preheating Equipment

All values in mm unless otherwise specified.

Description	Nominal value (Basic diameter)	Repair limit	Service limit	Correction and remarks
Air heater resistance	0.23 to 0.27 Ω			Replace.
Heater relay resistance	10.4 Ω			Replace.
Indicator resistance	12.2 Ω			Replace.
Time required before indicator becomes red hot	40 to 60 secs.			Check.

2-3 TIGHTENING TORQUE TABLE

2-3-1 Tightening Torque of Major Bolts and Nuts

Description		Thread size Dia. x Pitch mm	Torque N m(kgf m)	Remarks	
Engine proper	Main bearing cap bolt	M18×2.5	370(38)	Wet	
	Connecting rod nut	M13×1.25	115(12)	Wet	
	Crankshaft pulley attaching bolt	M14×1.5	175(18)		
	Idler shaft bolt	M16×2	115(12)		
	Camshaft gear attaching nut	M27×1.5	265(27)	Wet	
	Flywheel housing attaching bolt	M12×1.75	59(6)		
	Idler shaft nut (for attaching collar)	M16×1.5	98(10)		
	Flywheel attaching bolt	M16×1.5	255(26)	Wet	
	Cylinder head bolt	M14×2	195(20)	Wet	
	Rocker bracket attaching bolt	M10×1.5	34(3.5)		
	Rocker cover attaching screw	M10×1.25	9.8(1)		
Inlet and exhaust	Inlet manifold bolt	M10×1.5	29(3)		
	Exhaust manifold nut	M10×1.25	33(3.4)		
	Turbo- charger	Compressor wheel attaching nut		17 to 20 (1.73 to 2.07)	
		Compressor cover attaching bolt		6.9(0.7)	
	Turbine housing attaching bolt		17(1.7)		
Lubrication	Oil pump idler gear shaft nut	M12×1.25	59 to 78 (6 to 8)	LOCTITE No.262 to be applied	
	Oil filter center bolt	M16×1.5	59 to 69 (6 to 7)		
	Regulator valve	M27×1.5	98(10)		
	Check valve(to be mounted to crankcase)	M12×1.75	34(3.5)		
Cooling	Fan coupling bolt(to retain damper as well)	M12×1.75	59(6)		
	Cooling fan bolt	M10×1.5	42(4.3)		
		M12×1.75	59(6)		

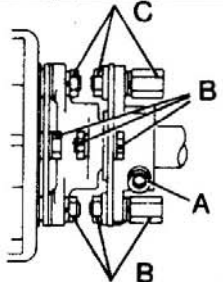
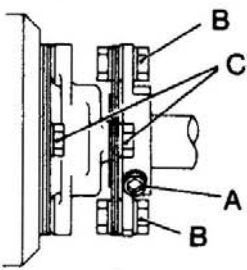
Description			Thread size Dia. x Pitch mm	Torque N m(kgf m)	Remarks
Fuel	Injection pump bracket attaching bolt		M10×1.5	42(4.3)	
Injection pump	Flange sleeve nut	P type		39 to 44 (4 to 4.5)	Tighten to specified torque repeatedly three times.
	Delivery valve holder	AD type		64 to 69 (6.5 to 7)	
		P type		110 to 115 (11 to 12)	
	Governor flyweight nut			49 to 59 (5 to 6)	
	Automatic timer round nut	AD type		83 to 98 (8.5 to 10)	
P type			125 to 145 (13 to 15)		
Injection pump	(AD type) 	A bolt		49 to 54 (5 to 5.5)	
		B bolt		29 to 34 (3 to 3.5)	
		C bolt		29 to 34 (3 to 3.5)	
	(P type) 	A bolt		74 to 83 (7.5 to 8.5)	
		B bolt		44 to 49 (4.5 to 5)	
		C bolt		44 to 49 (4.5 to 5)	
Injection pipe union nut			M14×1.5	29(3)	
			M12×1.5	20(2)	
Injection nozzle	Nozzle bolt(for attaching to cylinder head)		M8×1.25	15(1.5)	
	Inlet connector		M14×1.5	135(14)	
	Retaining nut			59 to 78 (6 to 8)	
	Nozzle cap nut			39 to 49 (4 to 5)	

Description			Thread size Dia. x Pitch mm	Torque N m(kgf m)	Remarks
Fuel	Fuel filter	Element		12 to 20 (1.2 to 2)	
		Connector bolt		34(3.5)	

2-3-2 Tightening Torque of General Bolts and Nuts

When parts are tightened, use the bolts and nuts specified in the specifications. Parts for which no bolts and nuts are specified should be tightened with general bolts and nuts torqued as shown below.

Unit : N m(kgf m)

Thread diameter mm	Pitch mm	4T (Head mark : 4 or ○)	7T (Head mark : 7 or ⊗)	8T (Head mark : 8 or ⊕)
5	0.8	2.0 to 2.9 (0.2 to 0.3)	4.0 to 5.8 (0.4 to 0.6)	5.0 to 6.8 (0.5 to 0.7)
6	1.0	4.0 to 5.8 (0.4 to 0.6)	6.9 to 10 (0.7 to 1.1)	7.9 to 11 (0.8 to 1.2)
		{ 4.0 to 5.8 } { 0.4 to 0.6 }	{ 7.9 to 11 } { (0.8 to 1.2) }	{ 8.9 to 13 } { (0.9 to 1.4) }
8	1.25	8.9 to 13 (0.9 to 1.4)	17 to 25 (1.7 to 2.6)	20 to 29 (2.0 to 3.0)
		{ 9.9 to 14 } { (1.0 to 1.5) }	{ 19 to 27 } { (1.9 to 2.8) }	{ 22 to 32 } { (2.2 to 3.3) }
10	1.25	19 to 27 (1.9 to 2.8)	35 to 53 (3.5 to 5.5)	45 to 58 (4.5 to 6.0)
		{ 21 to 30 } { (2.1 to 3.1) }	{ 39 to 58 } { (3.9 to 6.0) }	{ 50 to 63 } { (5.0 to 6.5) }
	1.5	18 to 26 (1.8 to 2.7)	33 to 49 (3.3 to 5.0)	43 to 105 (4.3 to 6.0)
12	1.25	34 to 49 (3.4 to 5.0)	69 to 93 (7.0 to 9.5)	84 to 105 (8.5 to 11)
		{ 38 to 53 } { 3.8 to 5.5 }	{ 79 to 105 } { (8.0 to 11) }	{ 89 to 115 } { (9.0 to 12) }
	1.75	31 to 46 (3.1 to 4.7)	64 to 83 (6.5 to 8.5)	74 to 98 (7.5 to 10)
14	1.5	59 to 83 (6.0 to 8.5)	120 to 155 (12 to 16)	130 to 175 (13 to 18)
	2.0	54 to 73 (5.5 to 7.5)	110 to 135 (11 to 14)	120 to 165 (12 to 17)
16	1.5	94 to 125 (9.5 to 14)	180 to 235 (18 to 24)	200 to 260 (20 to 27)
	2.0	89 to 115 (9.0 to 12)	160 to 215 (16 to 22)	190 to 250 (19 to 26)





NOTE : 1. Threaded portion and bearing surface are in dry state.
2. Tightening torque of flange bolts and nuts is shown in ().

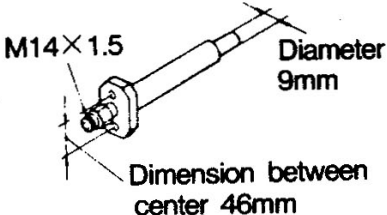
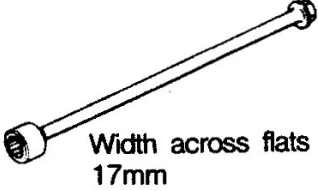
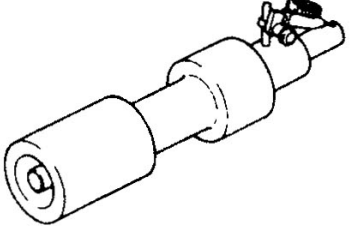
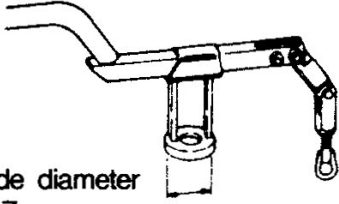
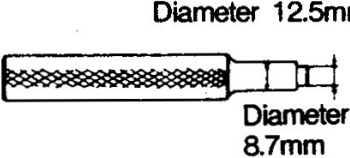
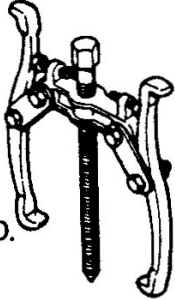
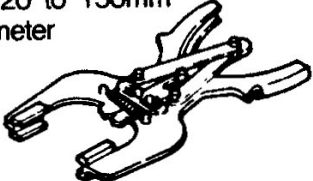

2-4 SEALANT, OIL AND GREASE



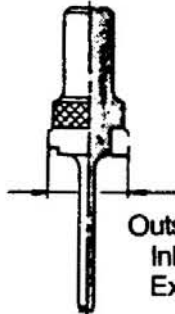
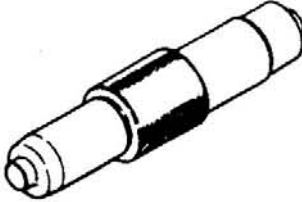
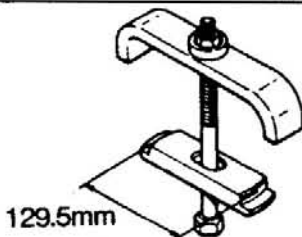

Location		Sealant, oil or grease	Application procedure
Oil main gallery plug and connector		HERMESEAL S2 or equivalent	Apply to threaded portions.
Idler gear shaft of oil pump		LOCTITE No. 262 or equivalent	Apply to threaded portions.
		MOLYCOAT or equivalent	Apply to portion sliding with idler gear bushing.
Water pump case		JT-6 grease or equivalent	Put 70g in case and pack bearing.
Water pump unit seal	Seat	Silicone oil	Portion for fitting impeller
	Outer cylinder	THREEBOND 1101 or equivalent	Portion for fitting case
Water thermo gage and water temperature sending unit in thermostat case		THREEBOND 1102C or equivalent	Apply to threaded portions.
SA type automatic timer		AUTO TIMER GREASE (ZEXEL Co., Ltd. product) or equivalent	Put 150g in case.
SP type automatic timer		Engine oil	Pour in 250 cc in case.
Starter	Sleeve bearing	MULTEMP PS-2 (KYODO YUSHI) or equivalent	Apply to inside.
	Internal gear		Apply to gear.
	Gear shaft		Apply to splines.
	Plunger		Apply to sliding portion.
	Lever		Apply to portion contacting plunger and clutch.
	Rear bracket		Put in rear.
	Thrust gap adjusting washer of gear shaft		Apply to all surfaces.
	Gear shaft		ALVANIA or equivalent

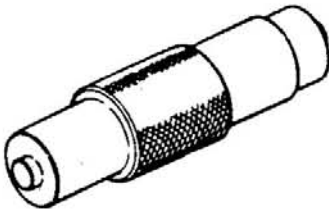
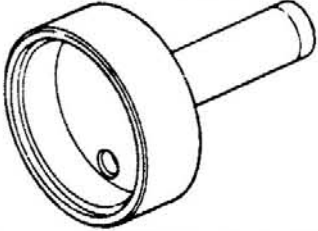
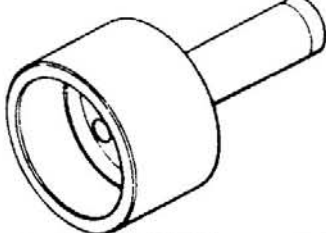
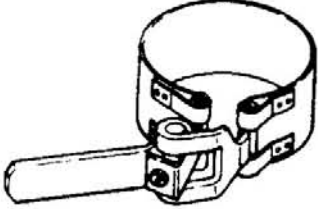
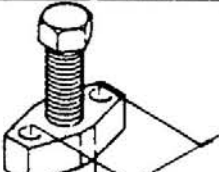
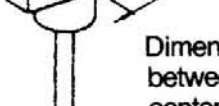
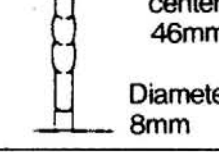
Engine

Tool name	Part No.	Shape	Use
Compression gauge adaptor	MH061461	 <p>M14×1.5 Diameter 9mm Dimension between center 46mm</p>	Measurement of compression pressure
Socket	31191-06100	 <p>Width across flats 17mm</p>	Removal and installation of starter
Injection pump centering tool	MH061270		Centering of bracket of AD type injection pump
Valve lifter	MH061668	 <p>Inside diameter 47mm</p>	Removal and installation of valve cotter
Valve lifter Hook	MH061679		
Nozzle tube remover	MH061232	 <p>Diameter 12.5mm Diameter 8.7mm</p>	Removal of nozzle tube
Gear puler	MH061061	 <p>Maximum pulling O.D. 200mm</p>	Removal of gear and pulley
Piston ring tool	31191-02900	<p>For 120 to 150mm diameter</p> 	Removal and installation of piston ring

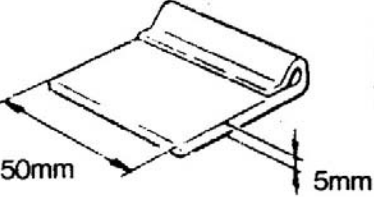
Tool name	Part No.	Shape	Use
Rocker bushing pulley	MH061236		Removal and installation of rocker bushing
Valve guide puller	30091-08100		Removal and installation of valve guide
Valve seat insert caulking tool	Inlet MH061650	 <p data-bbox="869 985 1085 1086">Outside diameter Inlet 59mm Exhaust 54mm</p>	Installation and caulking of valve seat insert
	Exhaust MH061651		
Idler gear bushing puller	MH061228		Removal and installation of idler gear bushing
Cylinder liner extractor	MH061490	 <p data-bbox="678 1668 790 1691">129.5mm</p>	Extraction of cylinder liner
Cylinder liner installer	31191-03101	 <p data-bbox="877 1736 1085 1803">Outside diameter 129.5mm</p>	Installation of cylinder liner

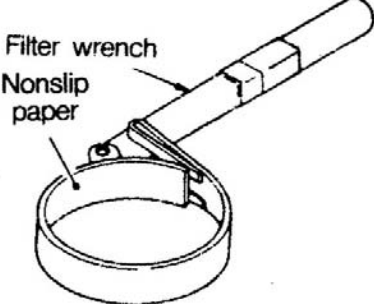
Tool name	Part No.	Shape	Use
Connecting rod bushing puller	MH061238		Removal and installation of connecting rod bushing
Oil seal slinger installer	MH061652		Installation of rear oil seal slinger
Front slinger installer	MH061247		Installation of front slinger
Piston guide	31191-03200		Insertion of piston
Nozzle tube stamp	MH061229		Installation of nozzle tube
Nozzle tube installer flange	MH061416		Installation of nozzle tube
Nozzle tube installer bolt	MH061231	 <p data-bbox="900 1406 1031 1525">Dimension between centers 46mm</p> <p data-bbox="884 1559 995 1615">Diameter 8mm</p>	Installation of nozzle tube
Valve stem seal installer	ME067431		Installation of valve stem seal
Socket	MH061242	 <p data-bbox="687 2092 1002 2119">Width across flats 14mm</p>	For exhaust manifold nut

Tool name	Part No.	Shape	Use
Tip clearance spacer	MC019470		Adjustment of fan shroud clearance
Water pump impeller puller	MH061417		Removal of water pump impeller
Filter wrench	MH061507		Removal of fuel filter element
Non-slip paper	MH061508		

4-1 DETERMINING TIME TO OVERHAUL

When determining a time to overhaul the engine, first check for a low compression pressure. If increased blow-by gases as well as low compression pressure are evident, it is safe to consider that the engine needs overhauling.

A low output, a radical increase in engine oil consumption, an increase in fuel consumption, low oil pressure, hard starting, etc. could be symptoms suggesting the need for overhauling the engine, but these are often due to effects of other causes and do not necessarily mean a time to overhaul the engine.

NOTE : 1. Measure the compression pressure at regular intervals and keep records of its changes.

2. When the engine is new or when parts are replaced, the compression pressure slightly rises due to inadequate seating of the piston rings, valve seats, etc. but will soon fall as the parts are worn down.

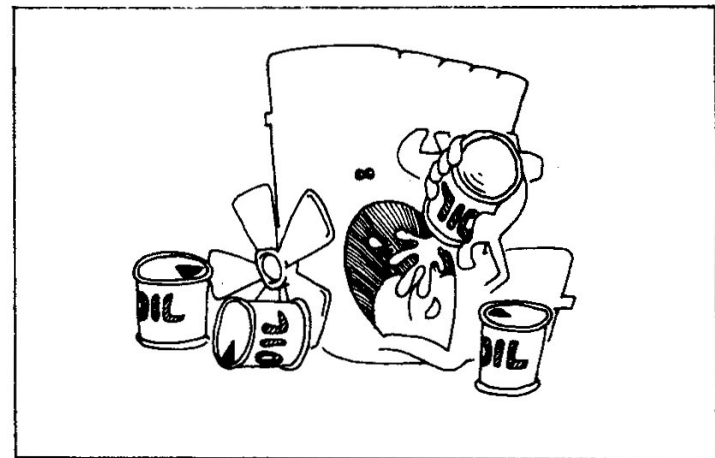
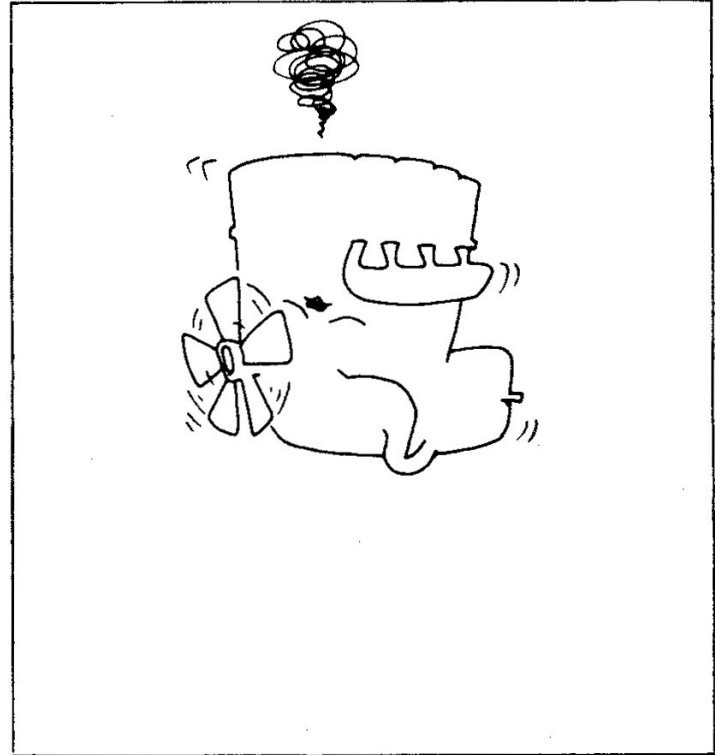

4-1-1 Measurement of Compressor Pressure

- (1) Allow the engine to warm up until the engine coolant temperature reaches 75 to 85°C.
- (2) Remove all injection nozzles from the cylinder head.

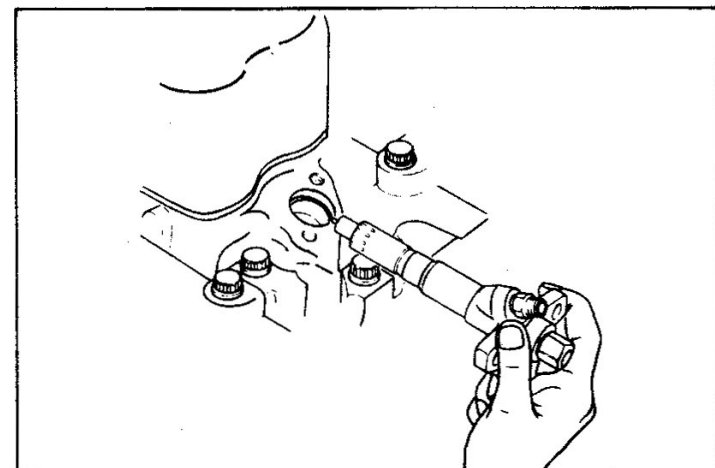

NOTE : Put a cover on the injection nozzle mounting holes and injection pipes to prevent entry of dust and dirt.

- (3) Install a special tool(the Pressure Gauge Adaptor) to the injection nozzle mounting hole together with the gasket and connect a measuring instrument(the Compression Gauge).
- (4) Operate the starter to rotate the engine and read the pointer of the compression gauge when the engine speed is 200 rpm.
- (5) If the reading is below the repair limit, disassemble and check.

NOTE : 1. Since the compression pressure varies with the engine speed, make sure that the engine speed is measured at the same time.

2. Since the wear and other conditions differ from cylinder to cylinder, be sure to measure all the cylinders.

Measuring one cylinder and estimating the rest could result in a wrong decision.

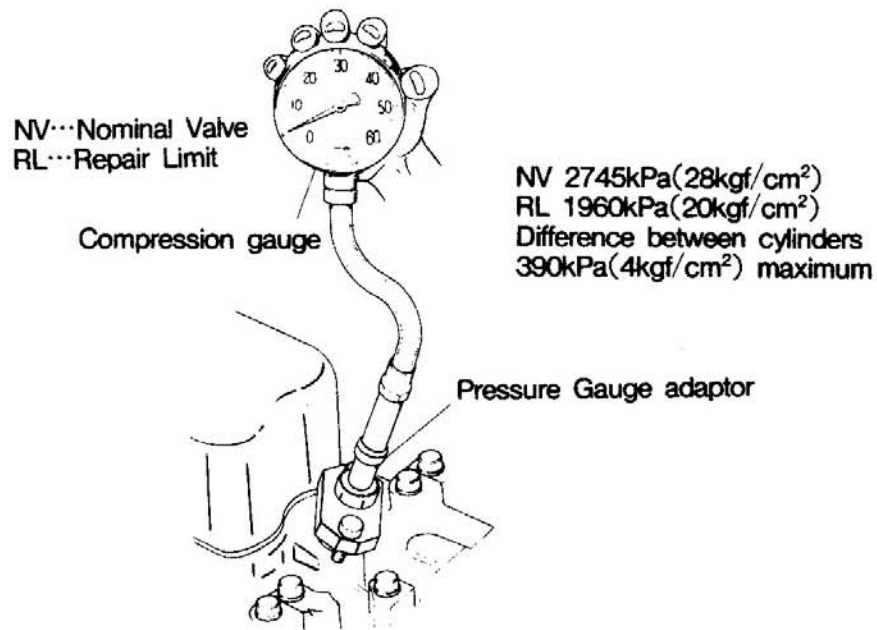

4-1-2 Engine Oil Consumption

The engine oil consumption could increase, depending on the operating condition. engine oil quality, oil leakage, etc. Check the compression pressure as well as the oil consumption from the overall point of view before making a decision.

4-1-3 Low Oil Pressure

- (1) Allow the engine to warm up until the oil temperature reaches 70 to 90°C
- (2) Measure oil pressures at idling and maximum speeds. If the readings are below the repair limit, overhaul the lubrication system.

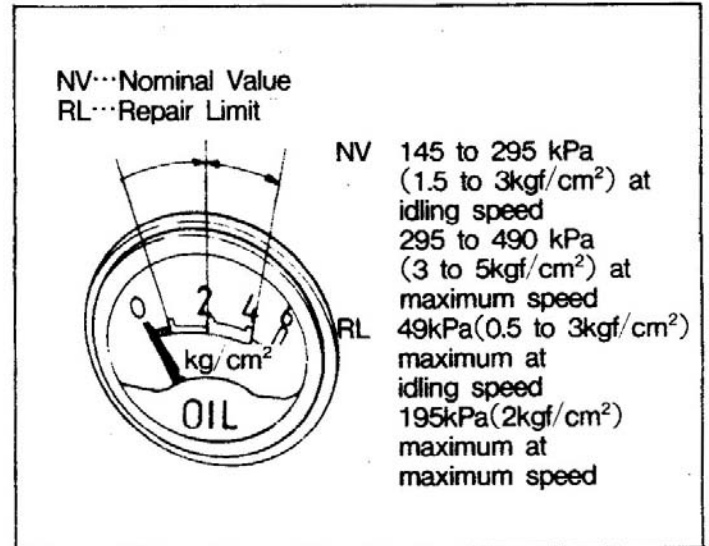

4-2 TROUBLESHOOTING

The symptoms and causes shown in this paragraph are typical examples. In actual operations, locate the causes according to the symptoms.

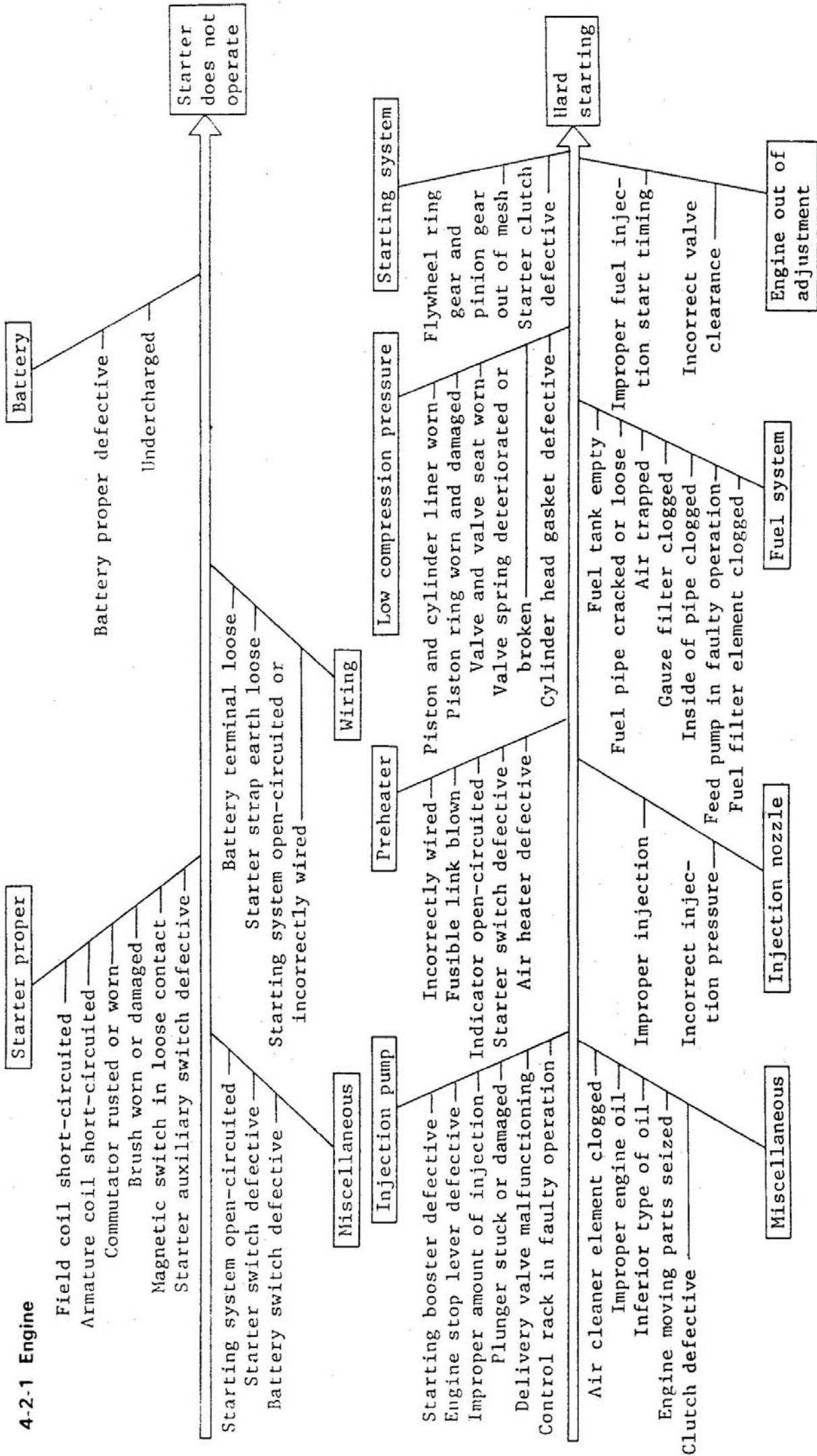

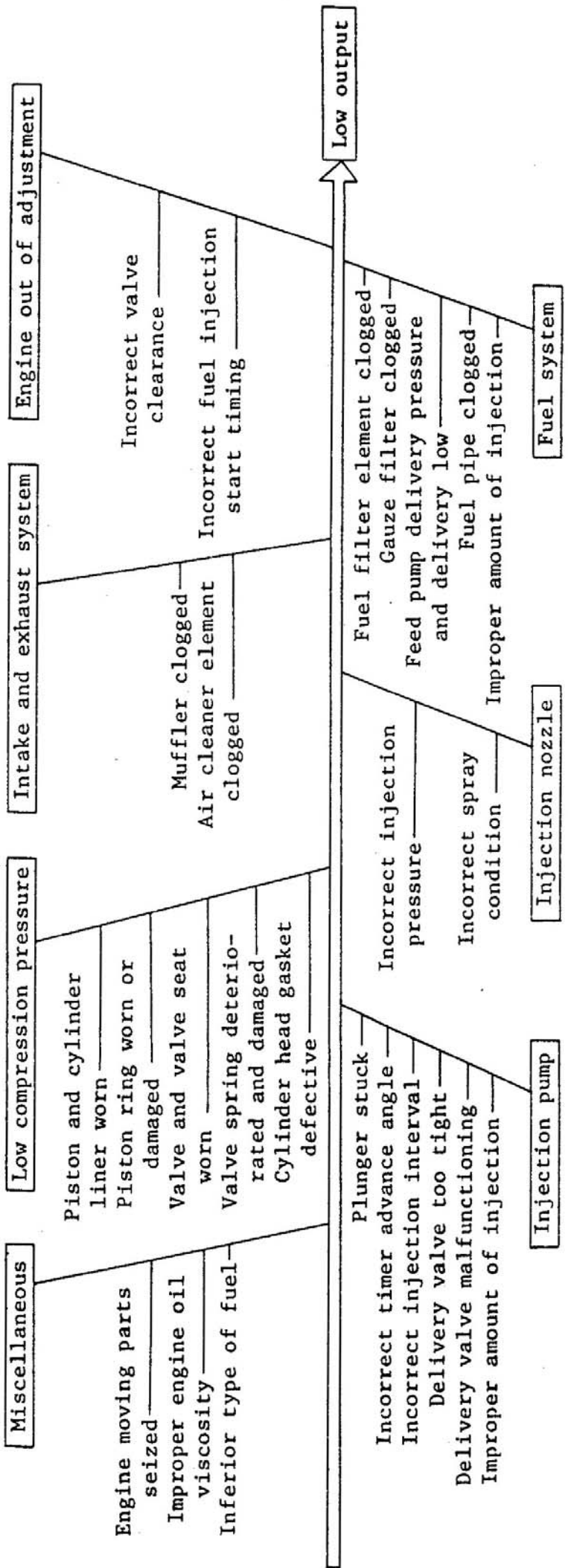
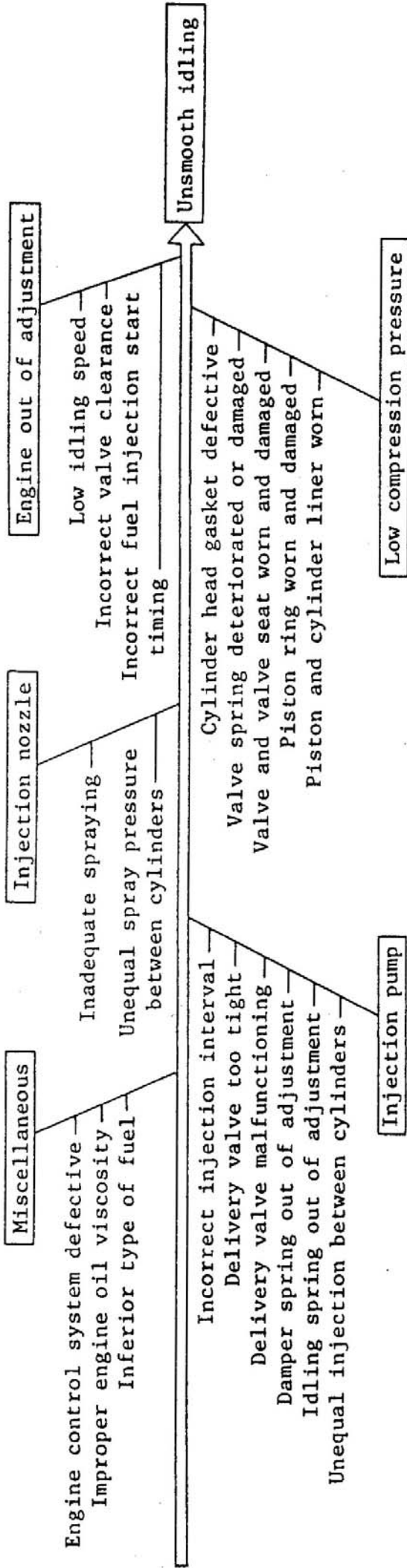

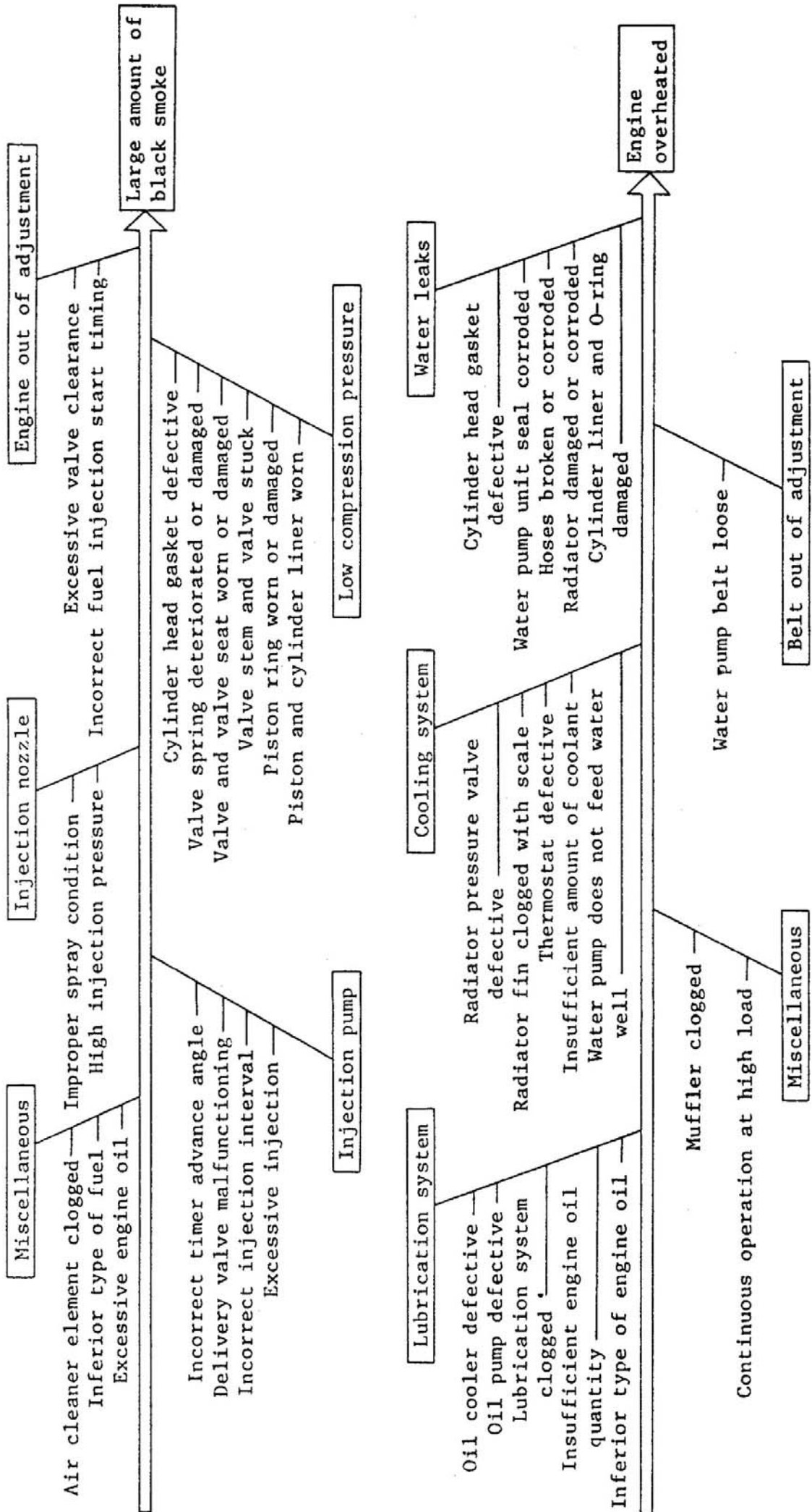

Miscellaneous

Air cleaner element clogged
 Inferior type of fuel
 Excessive engine oil

Injection nozzle

Improper spray condition
 High injection pressure

Engine out of adjustment

Excessive valve clearance
 Incorrect fuel injection start timing

Large amount of black smoke

Incorrect timer advance angle
 Delivery valve malfunctioning
 Incorrect injection interval
 Excessive injection

Injection pump

Cylinder head gasket defective
 Valve spring deteriorated or damaged
 Valve and valve seat worn or damaged
 Valve stem and valve stuck
 Piston ring worn or damaged
 Piston and cylinder liner worn

Low compression pressure

Lubrication system

Oil cooler defective
 Oil pump defective
 Lubrication system clogged
 Insufficient engine oil quantity
 Inferior type of engine oil

Cooling system

Radiator pressure valve defective
 Radiator fin clogged with scale
 Thermostat defective
 Insufficient amount of coolant
 Water pump does not feed water well

Water leaks

Cylinder head gasket defective
 Water pump unit seal corroded
 Hoses broken or corroded
 Radiator damaged or corroded
 Cylinder liner and O-ring damaged

Engine overheated

Muffler clogged

Continuous operation at high load

Miscellaneous

Water pump belt loose

Belt out of adjustment

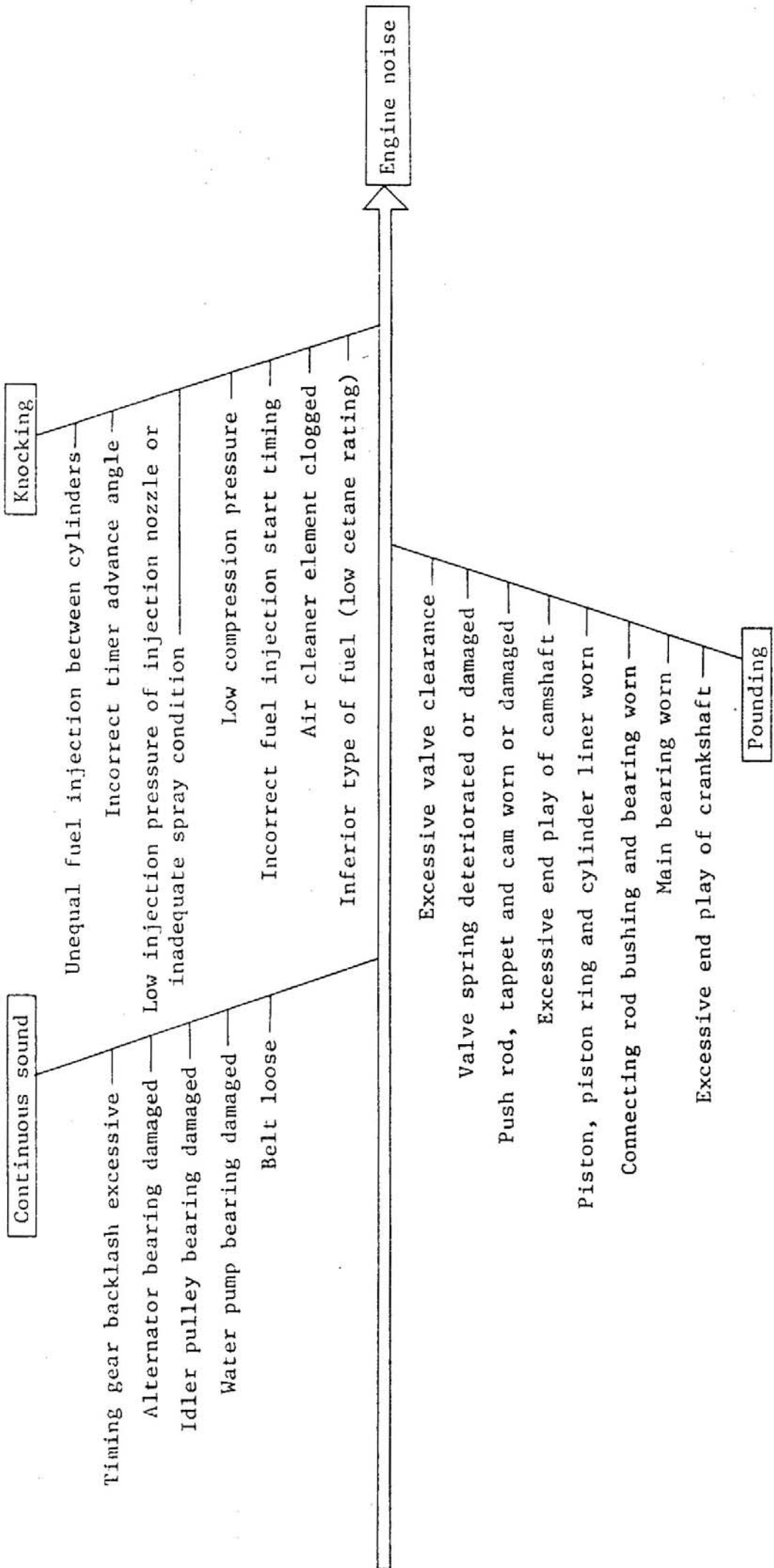

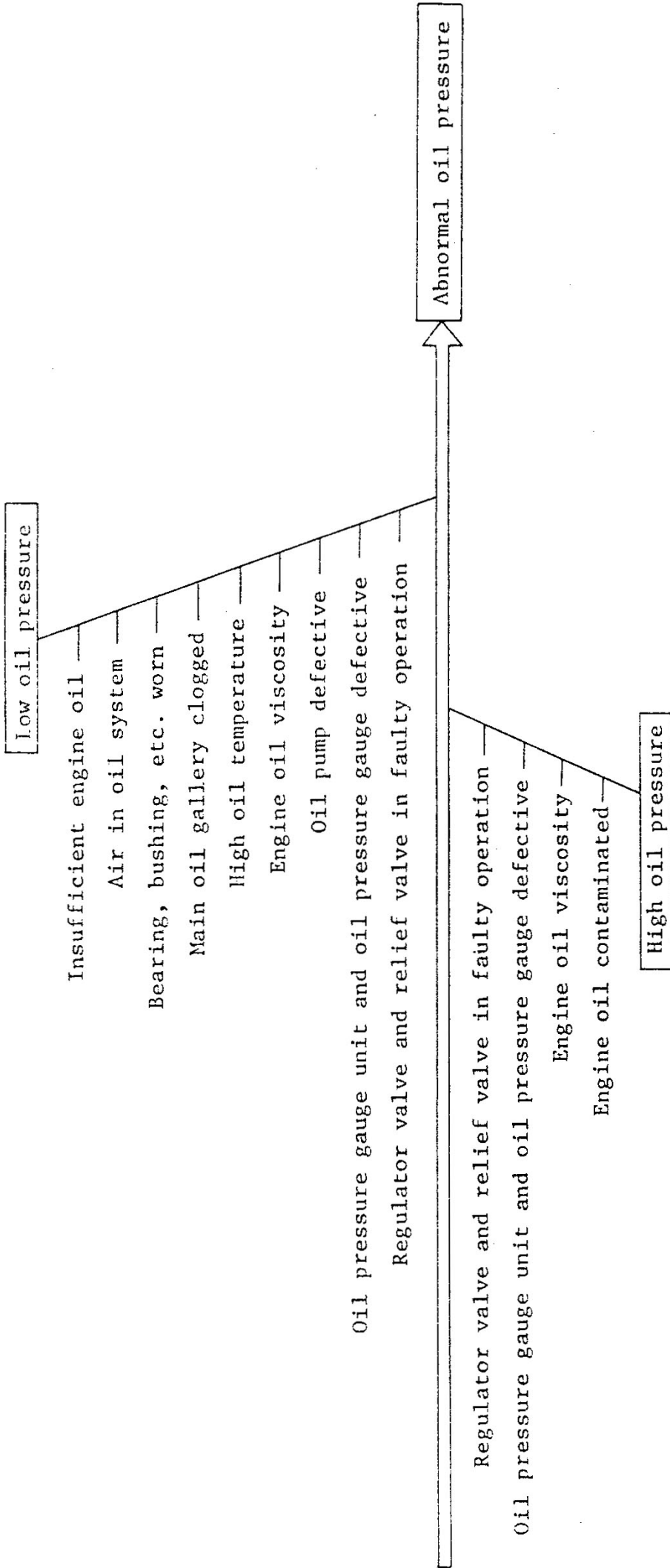

5-1 ENGINE ADJUSTMENT

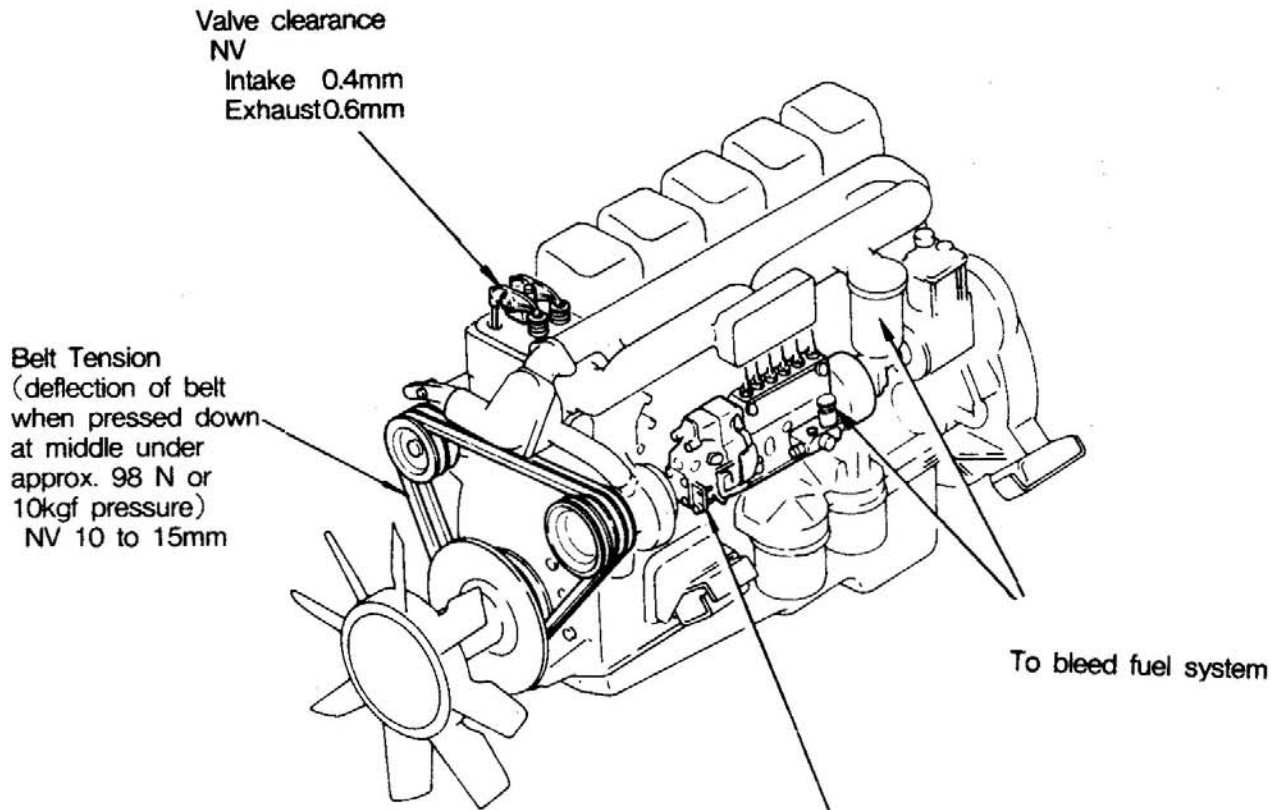

- Fuel injection timing
 - No-load minimum speed (Idling)
 - No-load maximum speed
- NV All three items vary on different specifications.

NV---Nominal Value

5-1-1 Inspection and Adjustment of Valve Clearance

Check and adjust the valve clearance as described below when the engine is cold.

- (1) Crank the engine to align the inscribed line 1.6 on the flywheel housing with the pointer of the inspection window in flywheel housing. The piston in the cylinder where the push rod is not pushing the rocker up is at the top dead center on the compression stroke.
- (2) If the piston in the No. 1 cylinder is at the top dead center on the compression stroke, check and adjust the valves marked ○ in the following table. If the piston in the No. 6 cylinder is at the top dead center on the compression stroke, check and adjust the valves marked × in the following table.

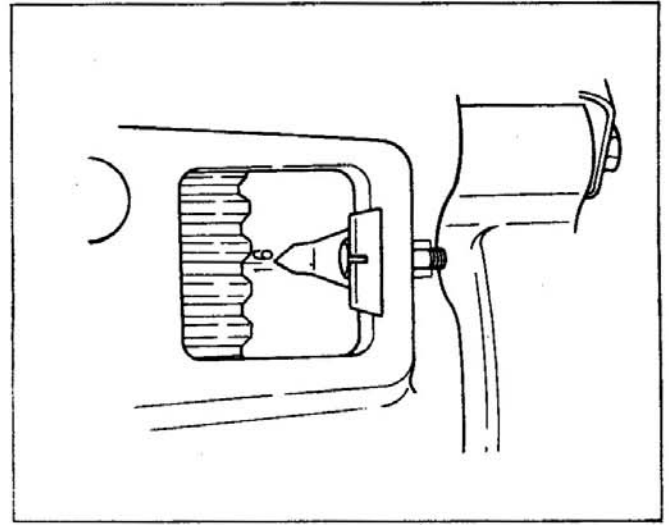

Crank the engine another rotation and check and adjust the valve clearance of all the valves.

Cylinder No.	1		2		3		4		5		6	
	In.	Ex.	In.	Ex.	In.	Ex.	In.	Ex.	In.	Ex.	In.	Ex.
Piston in No. 1 cylinder at TDC on compression stroke	○	○	○			○	○				○	
Piston in No. 6 cylinder at TDC on compression stroke				×	×			×	×		×	×

- (3) Measure the clearance between the rocker arm and valve cap with a thickness gauge to determine whether it is up to specification.

If the thickness gauge having the normal thickness fits in the clearance somewhat tightly, then the clearance is good.

If the clearance is out of the nominal value, loosen the lock nut and adjust the clearance with the adjusting screw.

After the clearance has been adjusted, tighten the lock nut to secure the adjusting screw.

NOTE : After the lock nut has been tightened, recheck the clearance.

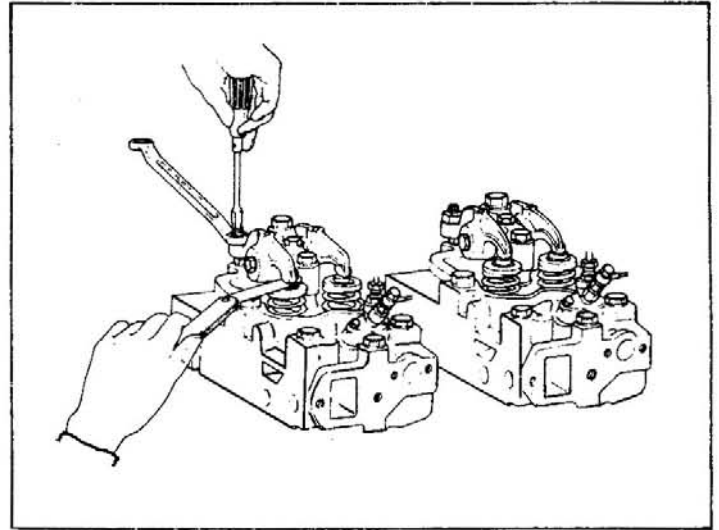

5-1-2 Bleeding Fuel System

Bleed the fuel system as described below.

- (1) Loosen the air plug of the fuel filter.
- (2) Turn the priming pump knob of the injection pump counterclockwise to let the knob float up.
- (3) Move the priming pump knob up and down by hand to force the fuel out until no air bubbles come out from the air plug.
- (4) After air bubbles have ceased to come out in the fuel, firmly tighten the air plug.
- (5) Move the priming pump knob several times up and down and turn down the knob, while pressing it down.

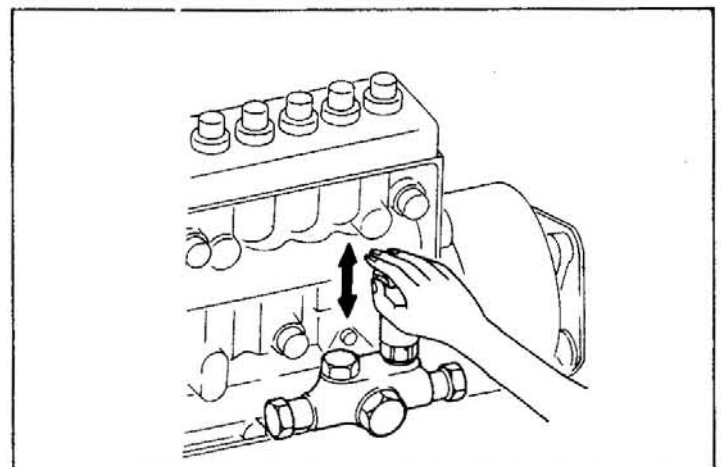
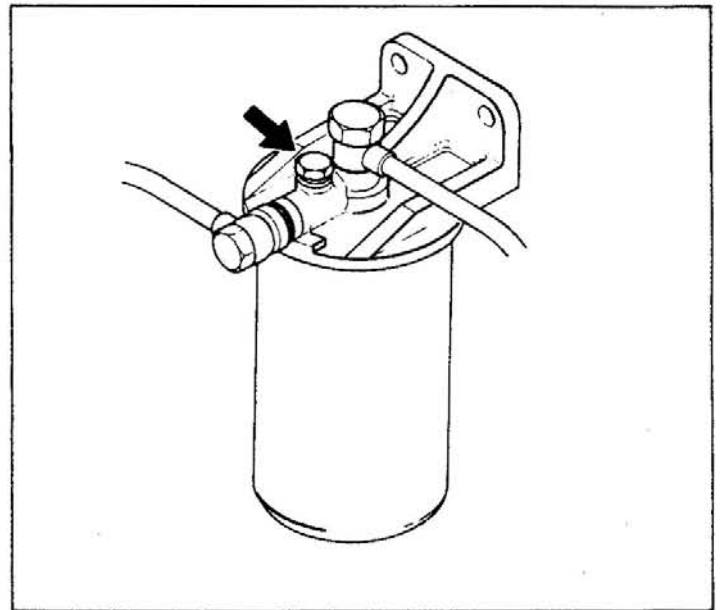

NOTE : Make sure that fuel spilt around is thoroughly wiped away.

(6) .Operate the starter to exhaust the air from inside the injection pump and injection pipe.

NOTE : Do not operate the starter continuously for more than 15 seconds.

5-1-3 Inspection and Adjustment of Fuel Injection Start Timing

(1) Crank the crankshaft more than 180° in normal direction to align the fuel injection start timing angle scale inscribed on the periphery of the flywheel with the pointer.

NOTE : If the engine is reversed (by cranking or when it is stopped), the automatic timer will stay operated in advancing direction and will not readily return to normal even if it is made to resume normal operation by turning the engine in normal direction for a while. Make sure that the crankshaft is cranked more than 180° in normal direction by hand.

(2) If, under the condition of Item (1), the pointer of the injection pump and the inscribed line of the automatic timer are in alignment, the injection start timing is correct.

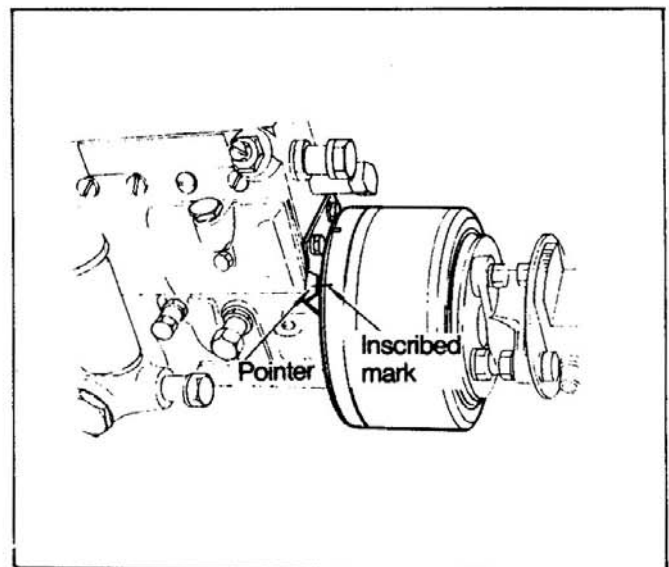
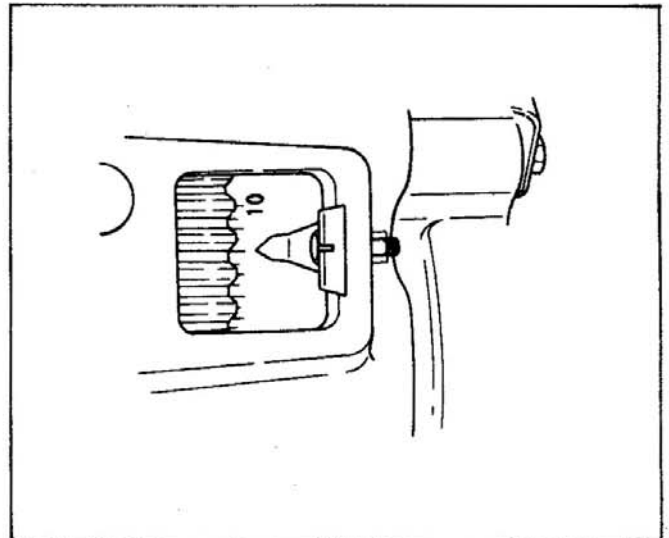

(3) If the fuel injection start timing is not correct, loosen the two timing adjusting bolts and adjust the timing by turning the automatic timer.

Tighten the adjusting bolts to the specified torque. Recheck the fuel injection start timing by the procedure described in Items(1) and (2).

NOTE : Do not loosen any other parts than the adjusting bolts.

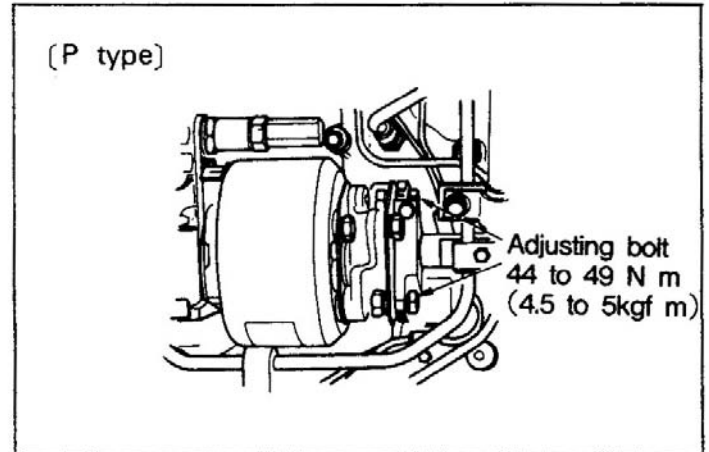
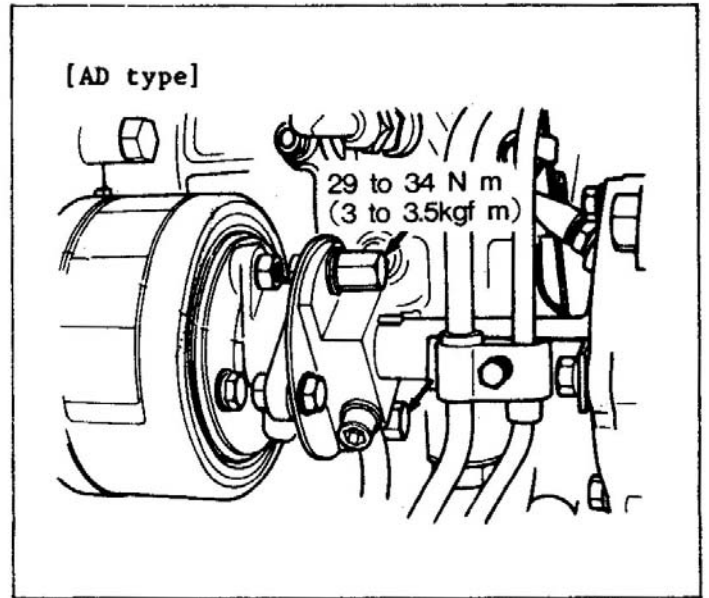

5-1-4 Inspection and Adjustment of No-load Minimum and Maximum Speeds

- (1) Inspection and Adjustment of Idling Run the engine at idle and check to ensure that the control lever touches the stopper bolt "A", and measure the engine speed at the time.

If the idling speed is not within the specified limits, adjust with the stopper bolt "A".

- (2) Inspection and Adjustment of No-load Maximum Speed

Push the control lever until it touches the stopper bolt "B". If the engine speed is out of the maximum speed limits, adjust with the stopper bolt "B".

NOTE : After idling adjustment, quickly move the control lever from the full load position to the idling position to verify that the engine does not stall and no hunting occurs. If abnormal condition occurs, make adjustment as far as the specified idling limits allow. If adjustment is impossible, disassemble and inspect the injection pump.

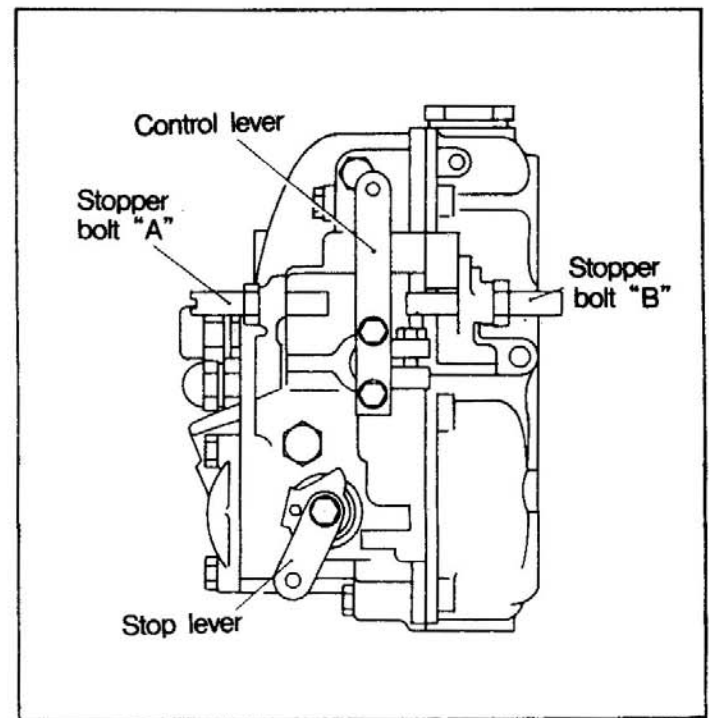

5-1-5 Inspection and Adjustment of V-belt Tension

- (1) Inspection

Adjust the belt tension so that when the middle of the belt is pressed strongly (approx. 98 N or approx. 10 kgf), the belt deflection will be up to specification.

Check the V-belt for damage. Make sure that a damaged and badly worn one is replaced.

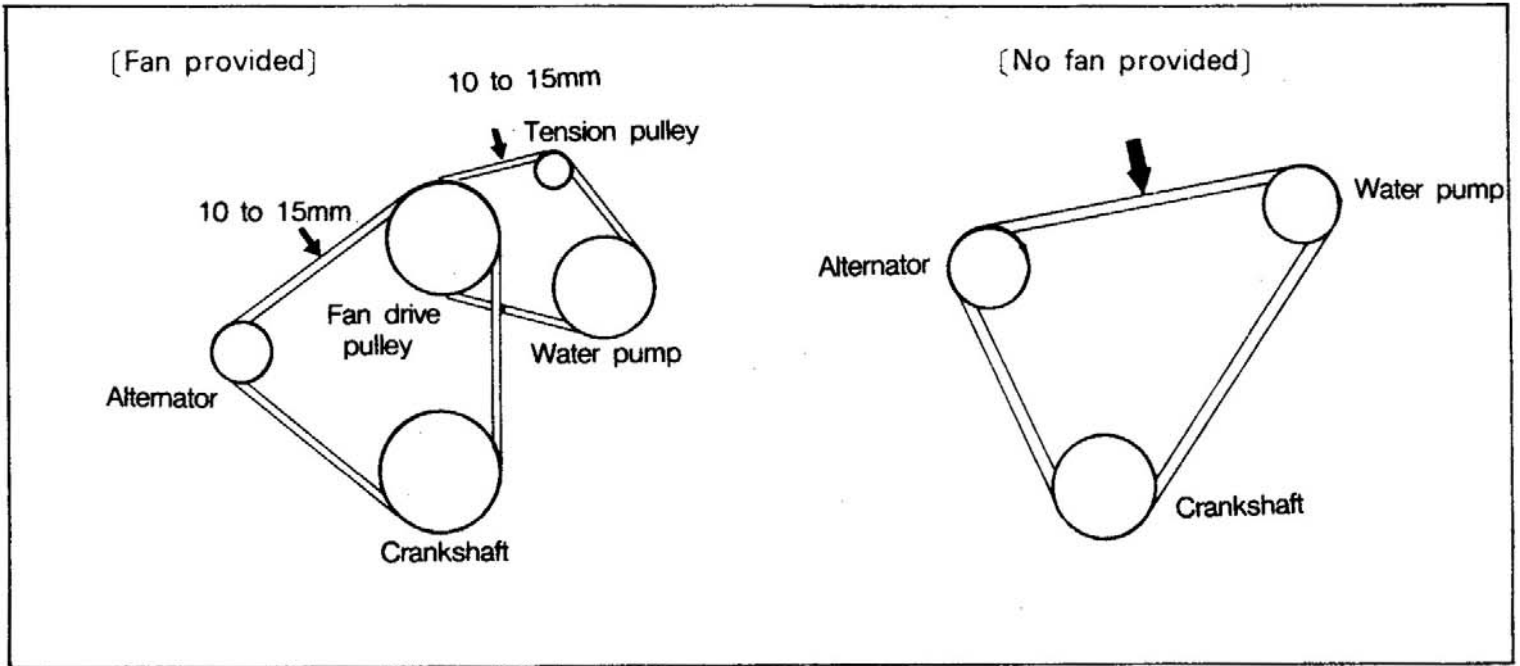

(2) Adjustment

Slightly loosen the alternator mounting bolt and adjusting plate mounting bolt and move the alternator to right and left to adjust the tension.

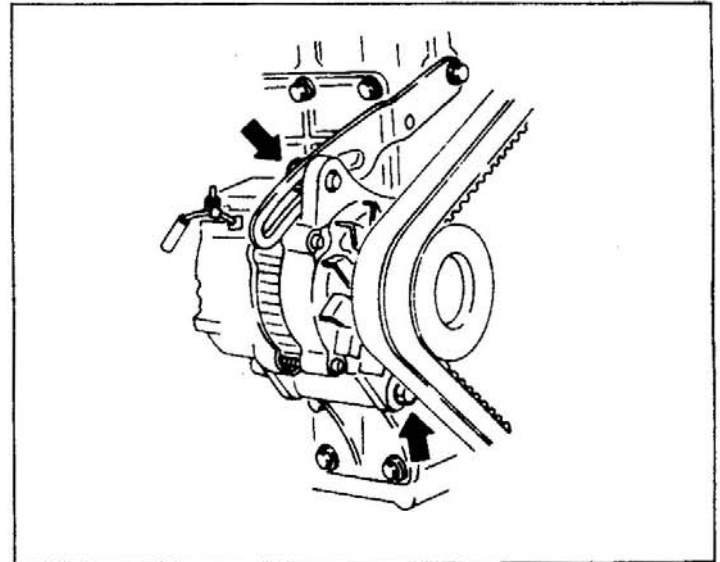

Slightly loosen the tension pulley nut and turn the adjusting bolt to adjust the belt tension.

After adjustment, tighten the tension pulley nut to the specified torque.

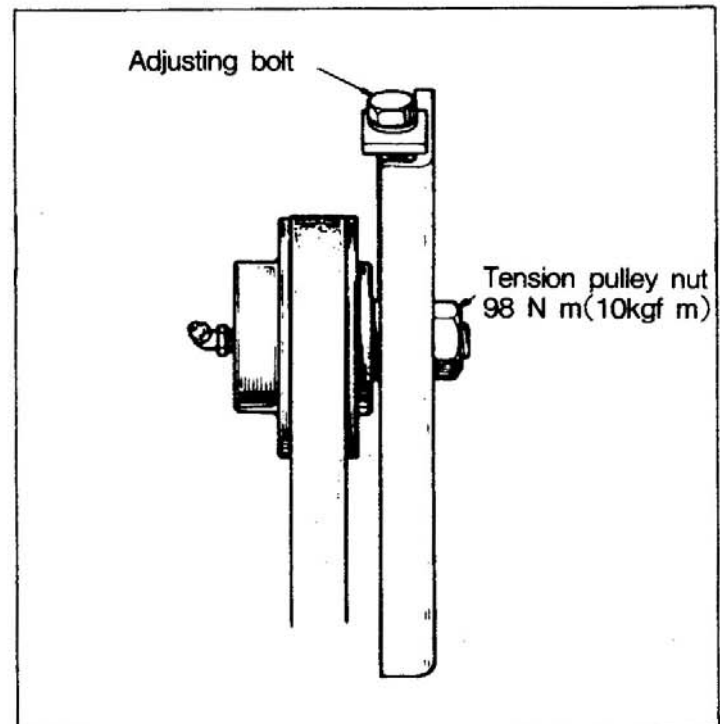

5-2 BREAK-IN OPERATION

After an engine has been overhauled, install it to a dynamometer and break it in.

5-2-1 Starting of Engine

- (1) Before starting the engine, check the coolant, engine oil and fuel and bleed the fuel system.
- (2) Heat the air heater for approx. 40 seconds to facilitate engine starting.
- (3) Place the load control lever to the full load position and start the engine with the starter.
- (4) After the engine has started, return the load control lever to let the engine run at idle.

5-2-2 Inspection during Engine Operation

Pay attention to the following points during operation. If anything wrong was noted, stop the engine and take corrective action immediately.

(1) Oil Pressure

When the oil temperature is over 70°C , the oil pressure should be 145 to 295 kPa(1.5 to 3.0 kgf/m^2) during idling and 295 to 490 kPa(3.0 to 5.0 kgf/m^2) during high speed operation.

(2) Water Temperature

Should be approx. 75 to 85°C

(3) Check for oil leaks, water leaks and fuel leaks.

(4) Check for Noise

Knocking may be heard while the water temperature is low, but will die away as the water temperature rises.

(5) Check for abnormal exhaust color and odor.

5-2-3 Break-in Operation

The load, speed and time for break-in operation are as shown below.

Model	Break-in operation		
	Speed rpm	Output kW(PS)	Time in minutes
D6AU	650	0(0)	5
	1000	22(30)	15
	1400	48(65)	15
	1800	88(120)	15
D6AZ	650	0(0)	5
	1000	37(50)	15
	1400	66(90)	15
	1800	117(160)	15

5-2-4 Inspection and Adjustment after Break-in Operation

- (1) Check all bolts and nuts for looseness.
- (2) Retighten the cylinder head bolts.
- (3) After the cylinder head bolts have been retightened, adjust the valve clearance.
(Refer to 5-1-1.)

This section contains the procedures for removal and installation of the various auxiliaries of an off-vehicle engine. The procedures are systematically described, presuming that the engine is to be overhauled.

Since the removal and installation procedures are described on a system-classified basis, their sequence may not always be consistent. Some changes may be made to the sequence when operations are performed.

6-1 PREPARATIONS

6-1-1 Preliminary Inspection of Engine

Before the engine is overhauled, check the cylinder compression pressure, engine oil consumption, startability, exhaust gas condition, diesel knocking and other noises, and keep records of all data. After disassembly, correction and reassembly, refer to the data as necessary.

To determine a time to overhaul the engine, refer to "Group 4 Determining Time to Overhaul."

6-1-2 Cleaning of Engine

The engine removed from a vehicle has oil, grease, dust and dirt deposits. Clean them from the engine, using a steam cleaner, etc.

When the engine is to be cleaned, the electrical devices(alternator, starter, etc.), V-belt, rubber hose, wiring, etc. should be removed beforehand.

NOTE : Before disassembly and cleaning, isolate symptoms and possible causes of problem which are not easily detected after disassembly and cleaning.



6-2 REMOVAL AND INSTALLATION

6-2-1 Electrical

When there is a need for removal of vehicle-borne and installed electrical parts, first disconnect the negative battery cable.

(1) Harness

When removing the terminals of engine harness, make alignment marks on the clamps to prevent misconnections at reinstallation.

(2) Starter

- 1 Starter
- 2 Starter relay

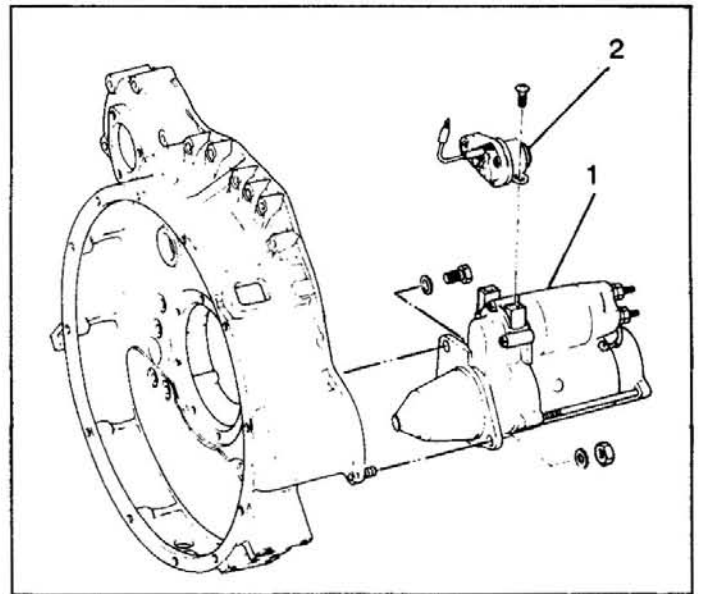

(3) Alternator

- 1 V-belt
- 2 Alternator

NOTE : After the alternator has been installed, adjust tension of the V-belt. (Refer to Item 5-1-5.)

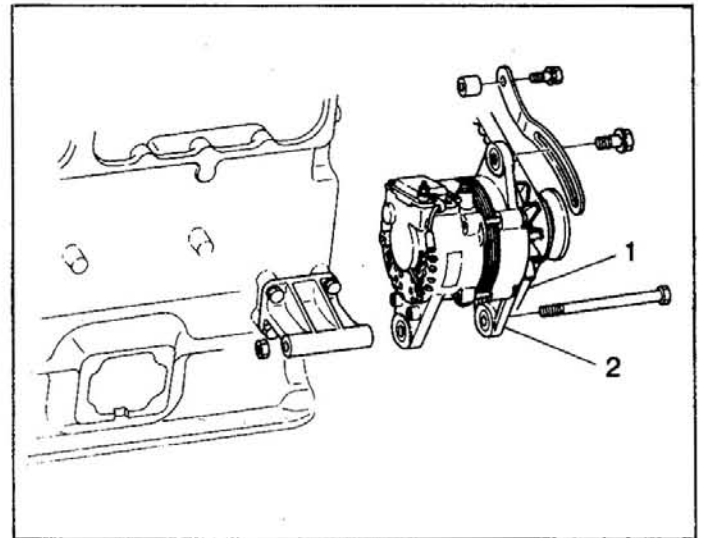

(2) Intake Air Heater

[Model D6AU]

- 1 Coupler
- 2 Air heater

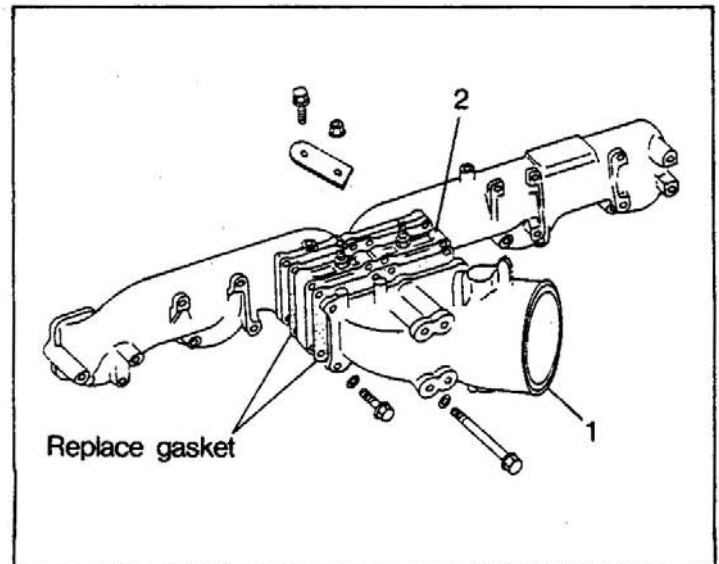

[Model D6AZ]

- 1 Inlet pipe
- 2 Air heater

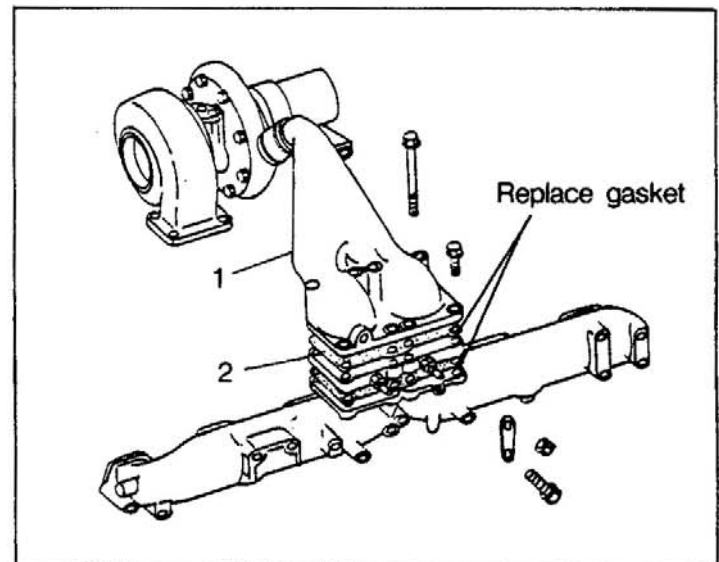

NOTE : When the air heater is installed, make sure that the embossed arrow mark of the air heater is directed toward the inlet manifold.

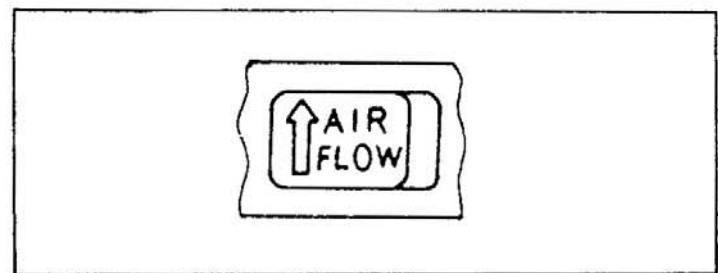

6-2-2 Inlet and Exhaust

(1) Air Cleaner

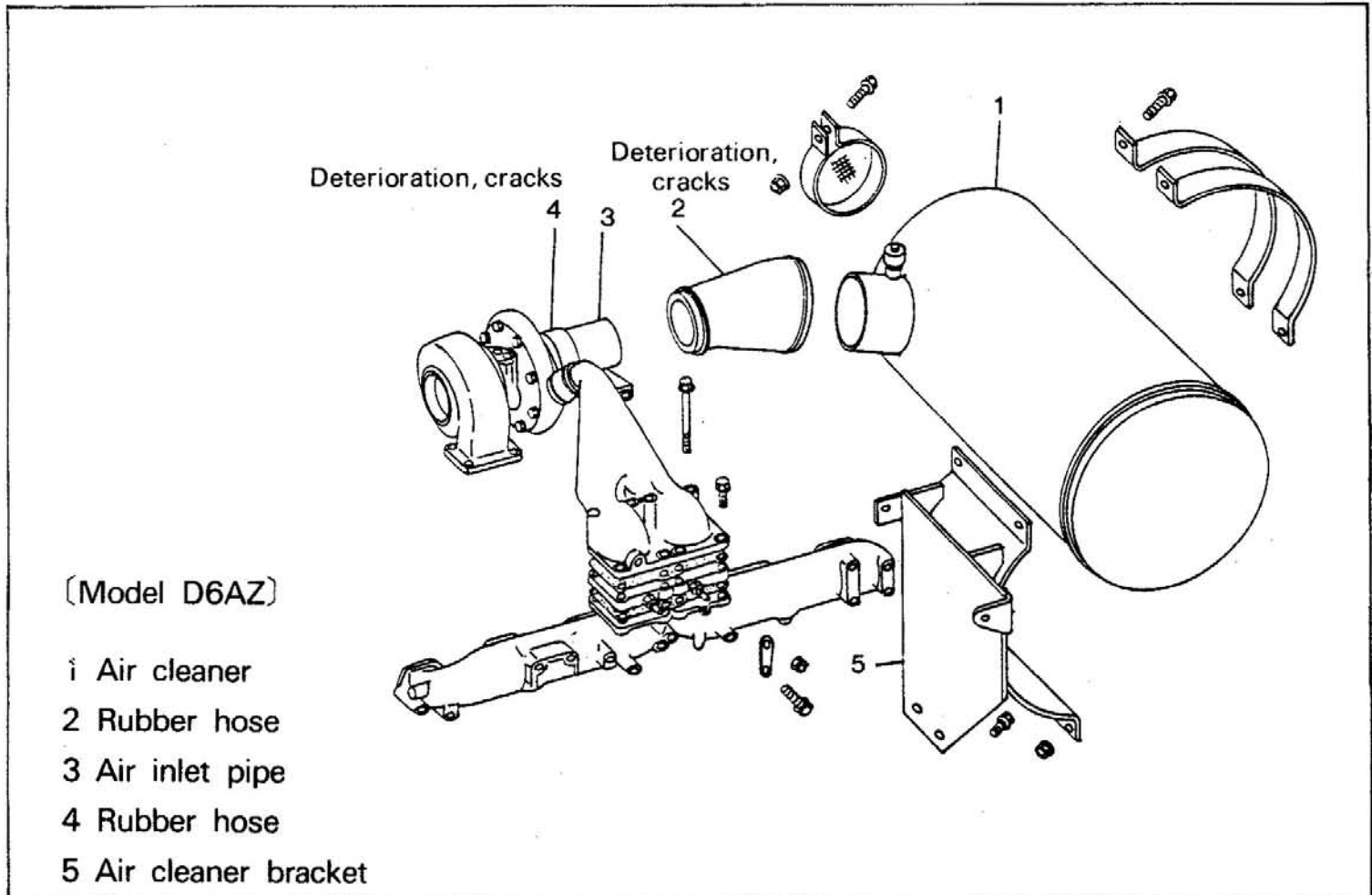
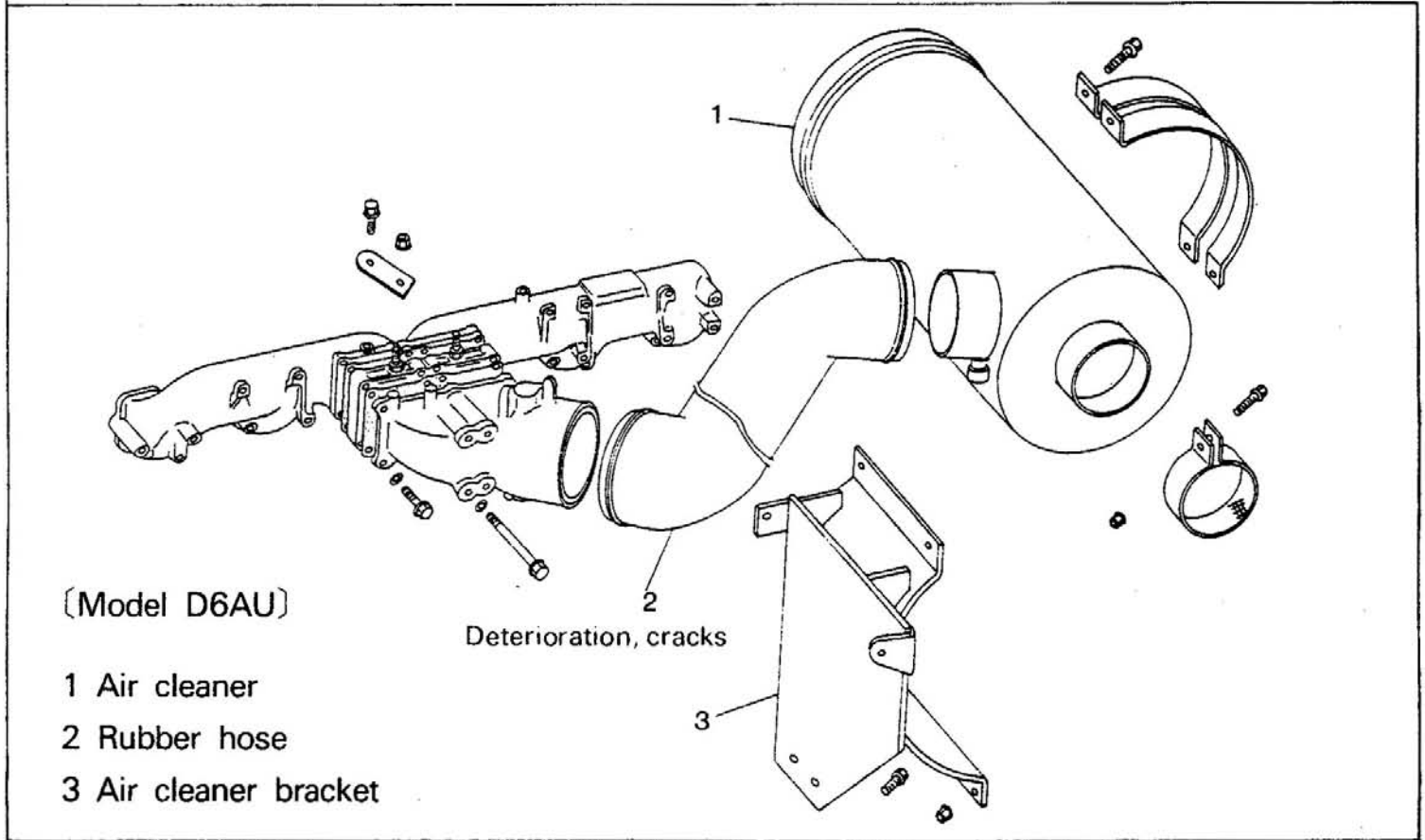

(2) Turbocharger

- 1 Oil inlet pipe
- 2 Oil outlet pipe

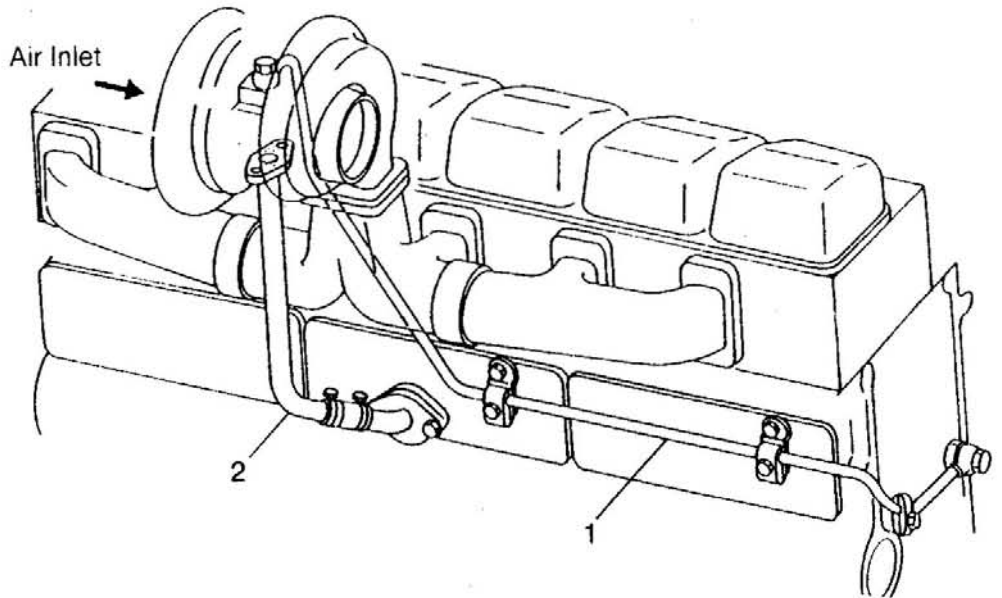

- 3 Inlet pipe
- 4 Rubber hose
- 5 Exhaust elbow
- 6 Ring
- 7 Turbocharger

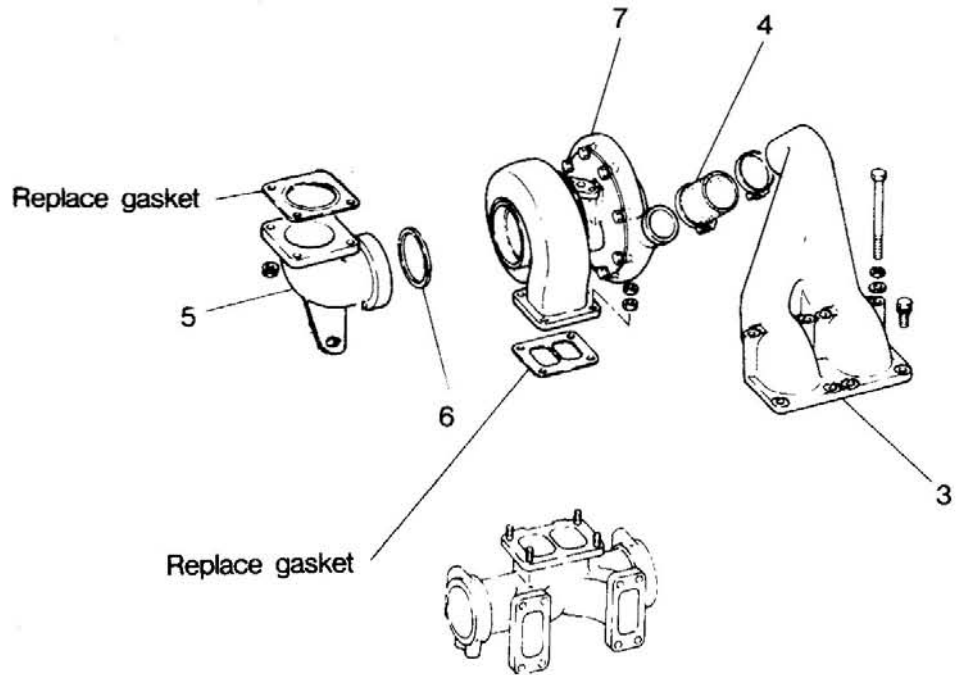

6-2-3 Fuel

(1) Fuel Filter

- 1 Inlet feed hose
- 2 Outlet feed hose
- 3 Fuel filter

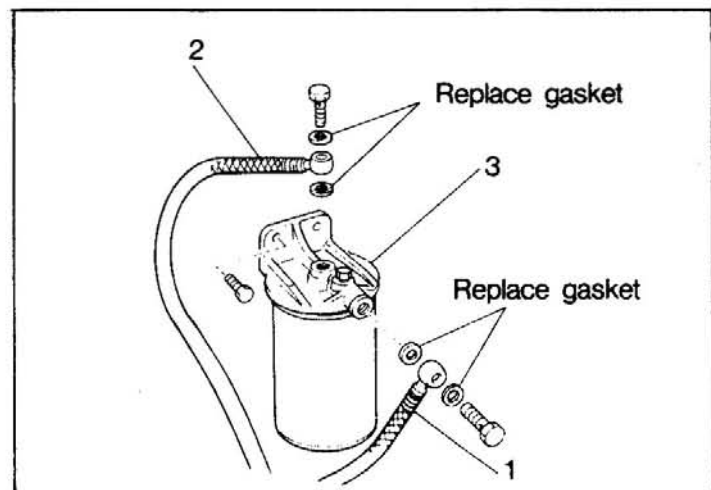

(2) Injection Nozzle

- 1 Injection pipe
- 2 Fuel return pipe
- 3 Fuel leak-off pipe
- 4 Injection nozzle
- 5 Dust seal

NOTE : Store the pipes, injection nozzles and injection pipe in such a way as to prevent entry of dust and dirt.

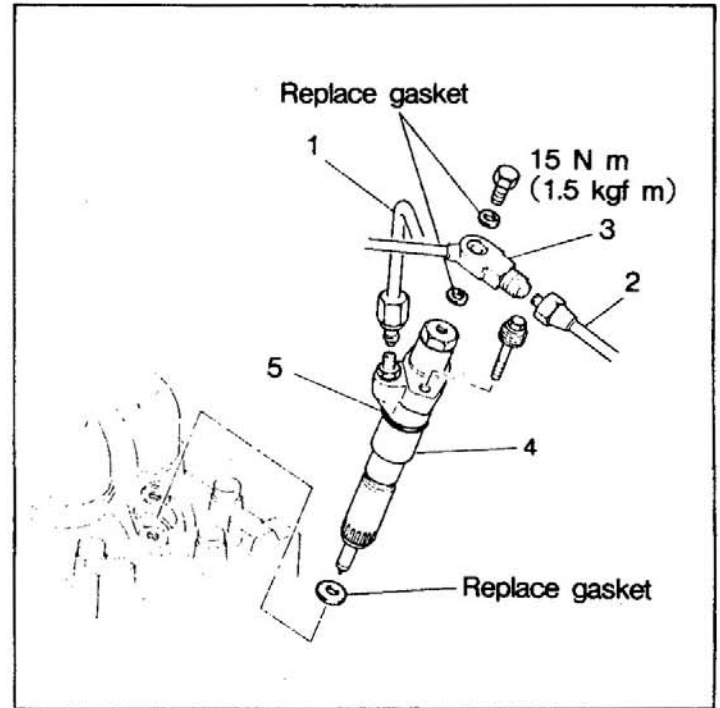

(3) Injection Pump

- 1 Inlet oil pipe
- 2 Outlet oil pipe
- 3 Overflow pipe
- 4 Injection pump

NOTE : To remove the injection pump, remove the bolts indicated by arrow in illustration from the coupling.

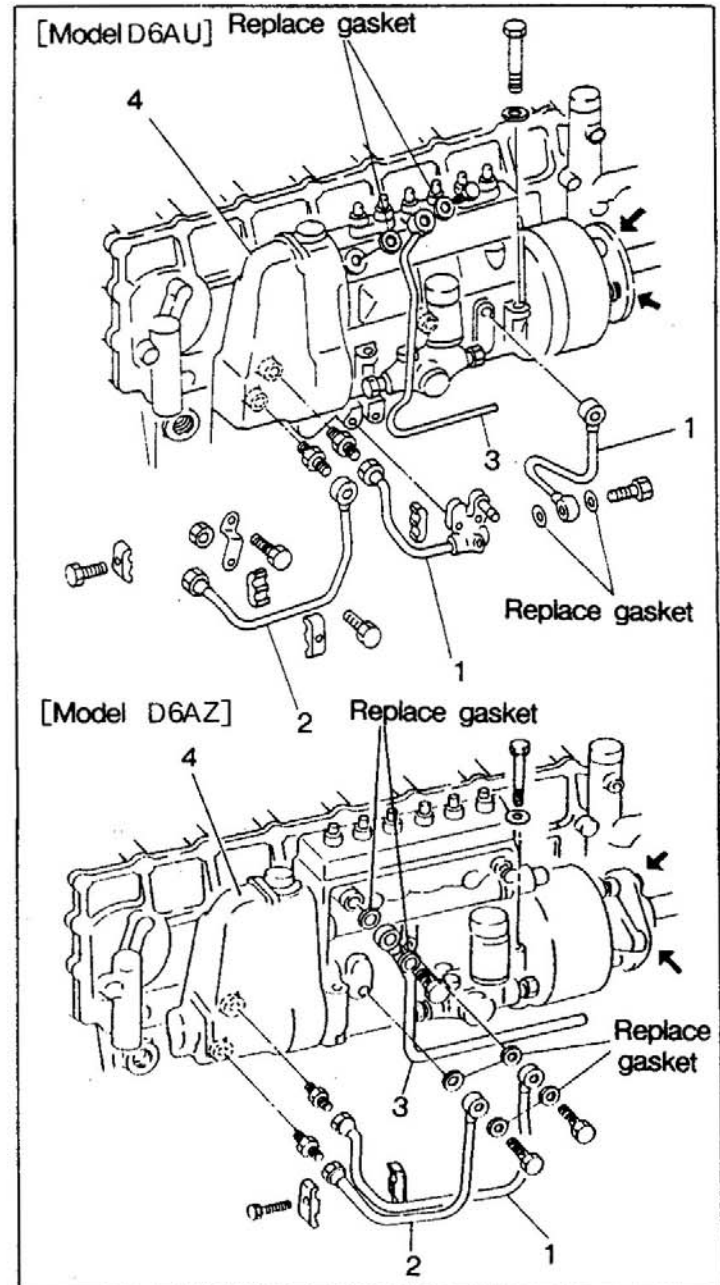

NOTE : The injection pump should be stored on woodblocks to prevent application of undue force to the timer section.

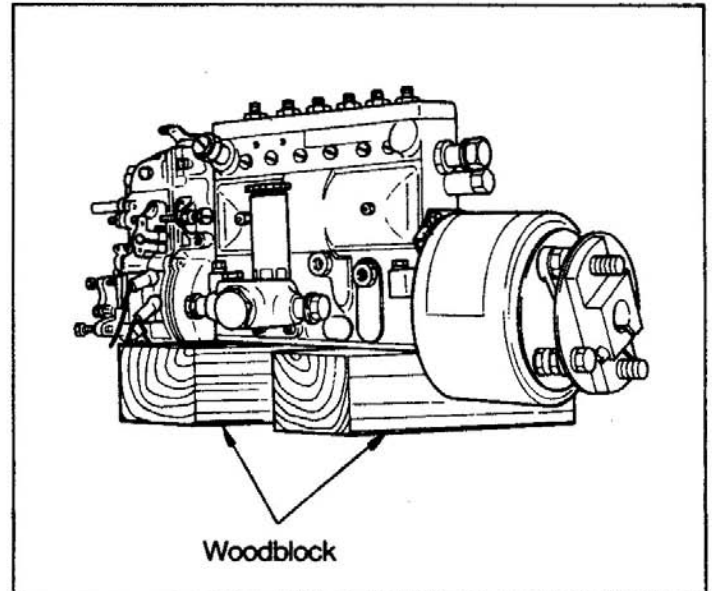

Installation Procedures

(a) Adjustment of injection pump bracket

- 1) Center the injection pump bracket by the following procedures.

Place Injection Pump Centering Tool (special tool) on the injection pump bracket, hold a dial indicator to the mandrel of the centering tool, and perform O-point adjustment.

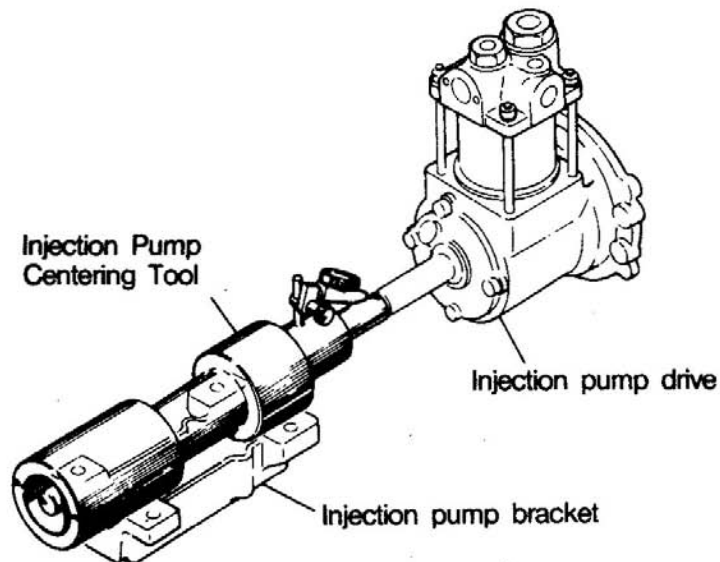

- 2) Slide the dial indicator of the centering tool toward the injection pump drive and measure the positions of the injection pump drive shaft shown in the illustration with the dial indicator.

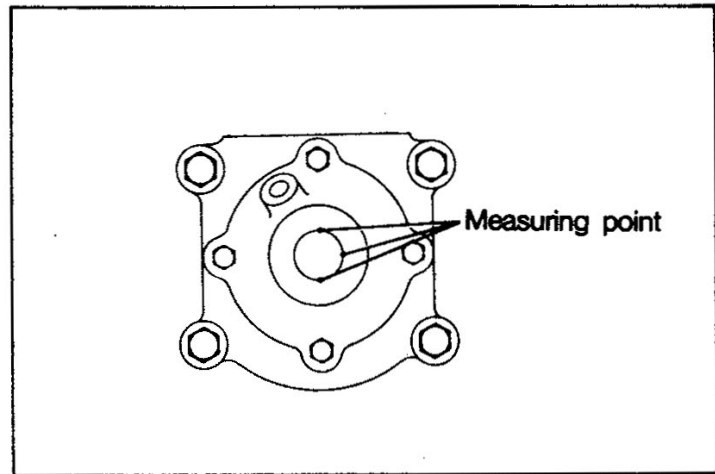

- 3) If the eccentricity between the mandrel and injection pump drive shaft is in excess of the nominal dimension, adjust by adding or removing injection pump bracket shims.

Shim Inserting Condition

- The number of shims inserted into a single point must not exceed three.
 - The front and rear shims must be equal in number.
 - The difference in number between the top and bottom shims must not exceed one.
- 4) After adjustment, tighten the tightening bolts to the specified torque before confirmation.

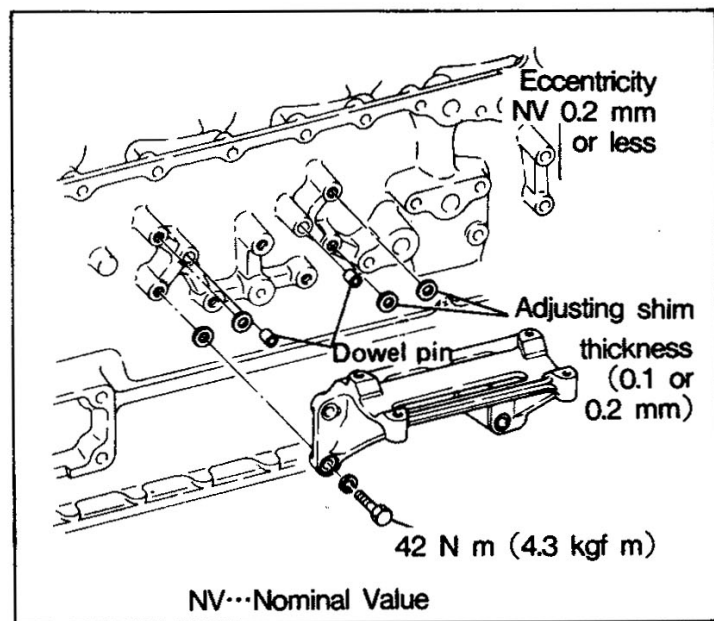

(b) Installation of injection pump

- 1) Crank the engine to adjust the No. 1 cylinder to the fuel injection timing. For this purpose, align the angle scale inscribed on the outer periphery of the flywheel with the pointer of the inspection window of the flywheel housing.

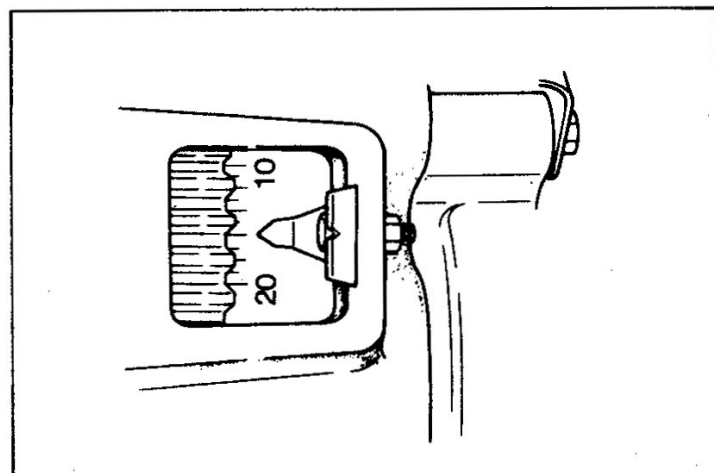

- 2) At this point, check to ensure that the keyway of the crankshaft of the injection pump drive is in the uppermost position.
If the keyway is not in the uppermost position, turn the engine crankshaft.

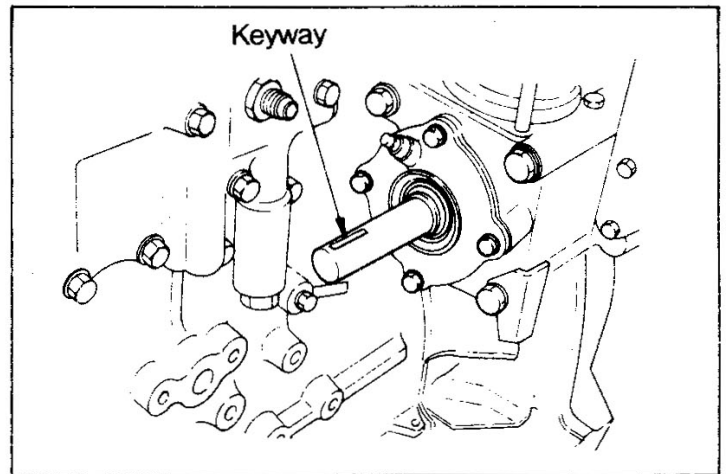

- 3) Align the pointer of the injection pump and the inscribed mark of the auto timer. (On engines with no auto timer, align the inscribed mark on the pump bearing cover with that on the pump side coupling.)

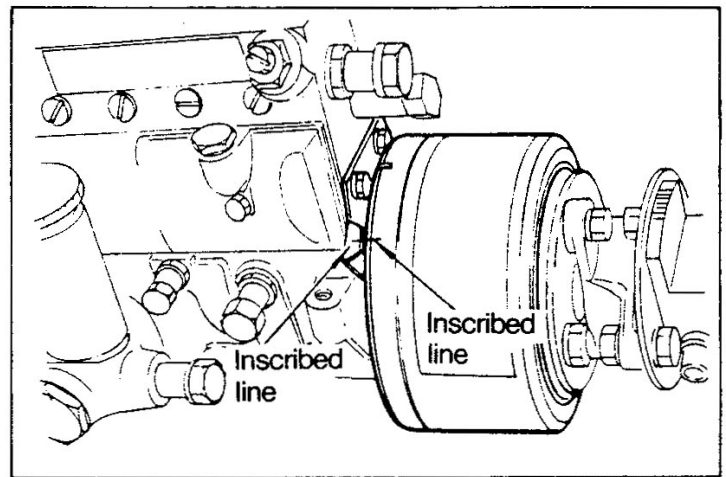

- 4) Install the driving coupling together with the coupling plate on the injection pump drive shaft.

Install the injection pump to the bracket. Move the driving coupling toward the cross coupling and tighten the coupling plate and cross coupling to the specified torque.

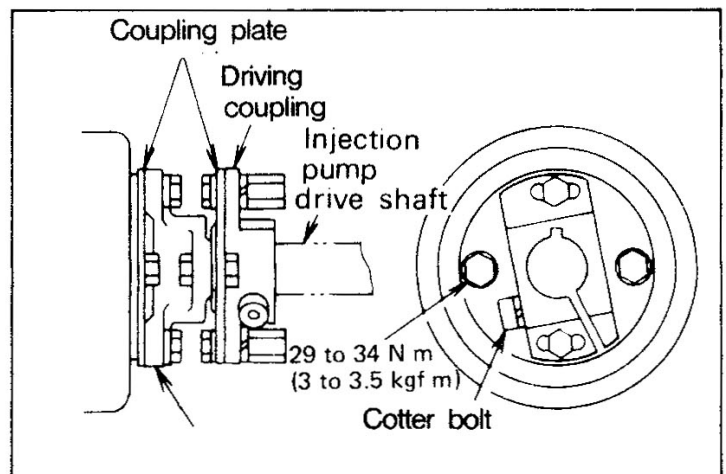

Then tighten the cotter bolt to the specified torque.

NOTE : After the injection pump has been installed, be sure to check and adjust the fuel injection timing. (Refer to 5-1-3).

6-2-4 INJECTION PUMP DRIVE

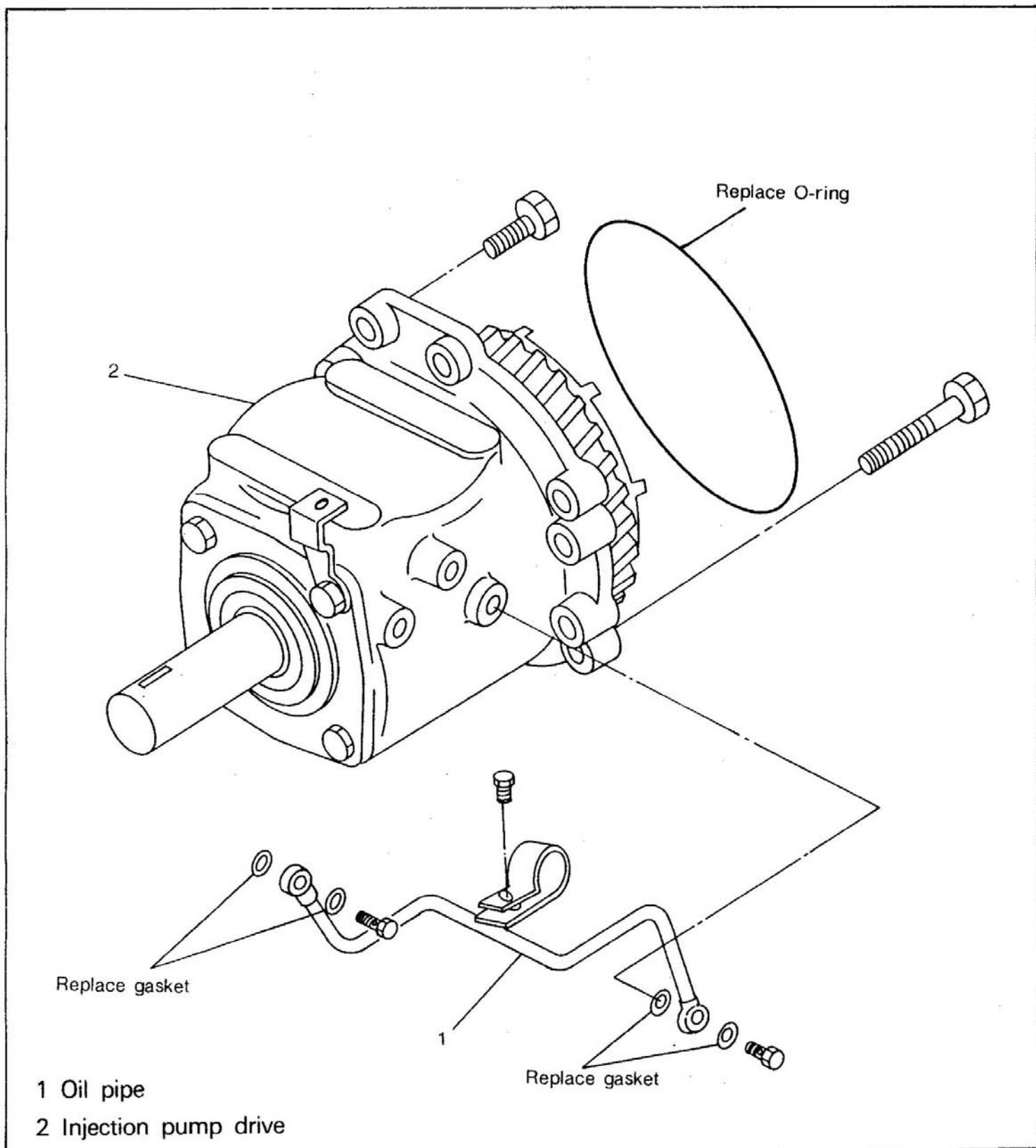

The injection pump gear mounted to the Injection pump drive must be put in correct mesh when the Injection pump drive is installed.

Install the Injection pump drive by the following procedure.

Injection pump drive Installation Procedure

- (1) Crank the engine to align the stamped mark "1, 6" on the periphery of the flywheel with the pointer of the inspection window in the flywheel housing and put the piston in the No. 1 cylinder of the engine at top dead center on the compression stroke.

If the piston in the No. 1 cylinder is at top dead center on the compression stroke, the No. 1 cylinder will have a valve clearance. If both inlet and exhaust valves have no valve clearance, the piston in the No. 6 cylinder will be at top dead center on the compression stroke. So let the engine rotate 360°

- (2) Remove the plug from the flywheel housing.

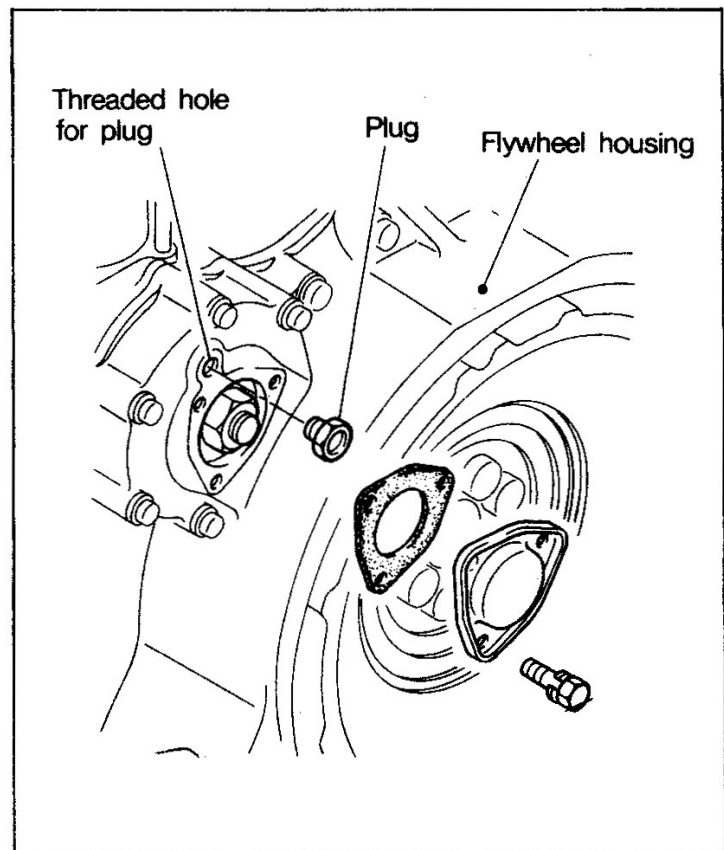
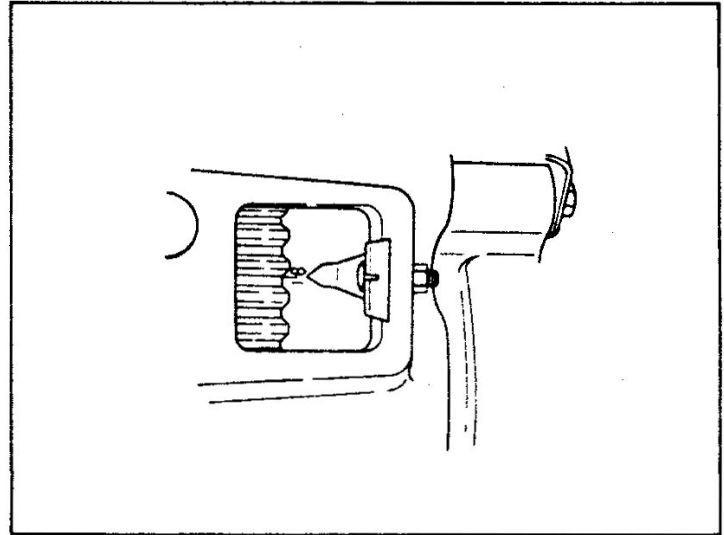

- (3) Insert the bolt (M10×1.5 about 100 mm long) from the rear end of the fly-wheel housing to support the injection pump drive. Using the bolt as a guide, insert the injection pump drive into the mounting hole of the flywheel housing. At the position where both ends of the injection pump gear and idler gear C have touched each other, align the inscribed line on the rear plate with that on the injection pump gear tooth surface, and then push the injection pump drive.

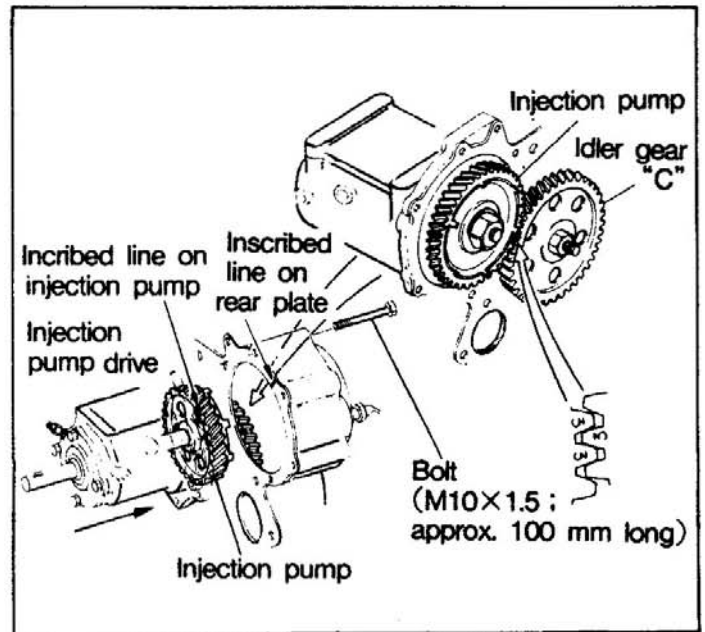

- (4) Look through the plug hole to confirm that the projection on the sensor plate is positioned at the center of the plug hole, and then secure the injection pump drive. If the projection on the sensor plate is not positioned at the center of the plug hole, remove the injection pump drive and perform Item(3) again.

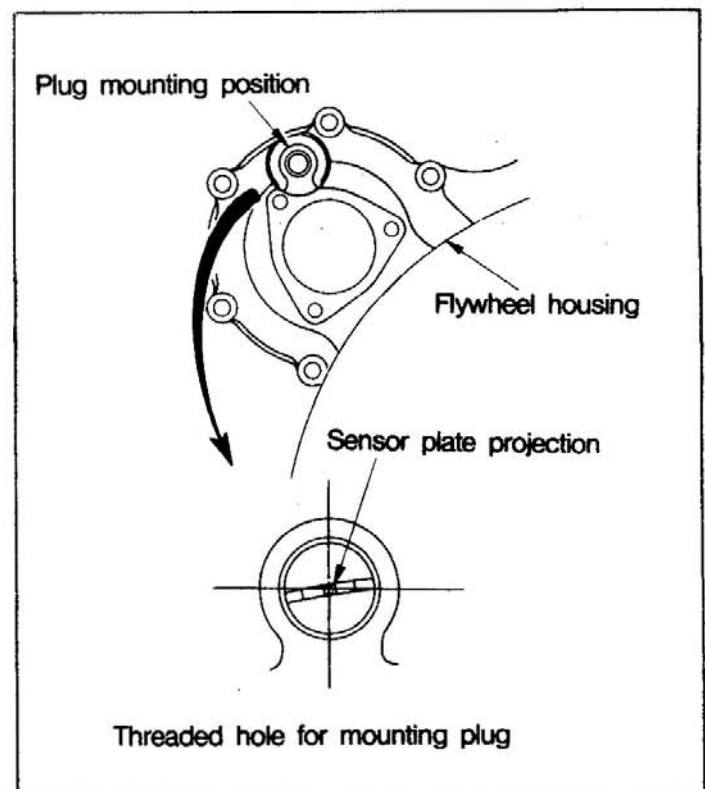

After the injection pump drive has been installed, install the plug.

NOTE : If the injection pump gear and idler gear C are misaligned a tooth, about half of the projection on the sensor plate will be hidden from the plug hole.

6-2-5 Cooling

- (1) Fan and Fan Drive

- 1 Fan
- 2 Fan drive

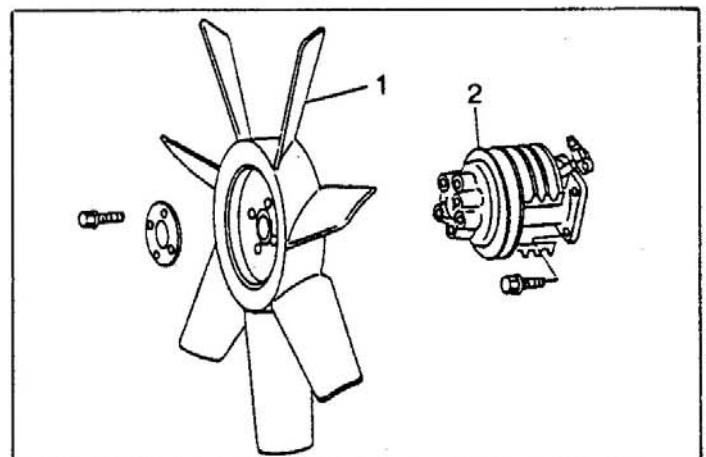

NOTE : Remove or install the fan drive by operating the tension pulley.

After installation, adjust the tension of the V-delt.
(Refer to 5-1-5.)

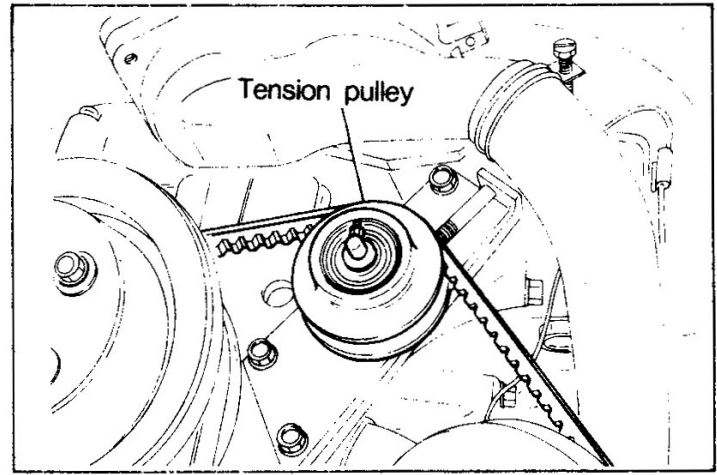

(2) Fan Drive Pulley and Torsional Damper

- 1 Fan drive pulley
- 2 Torsional damper

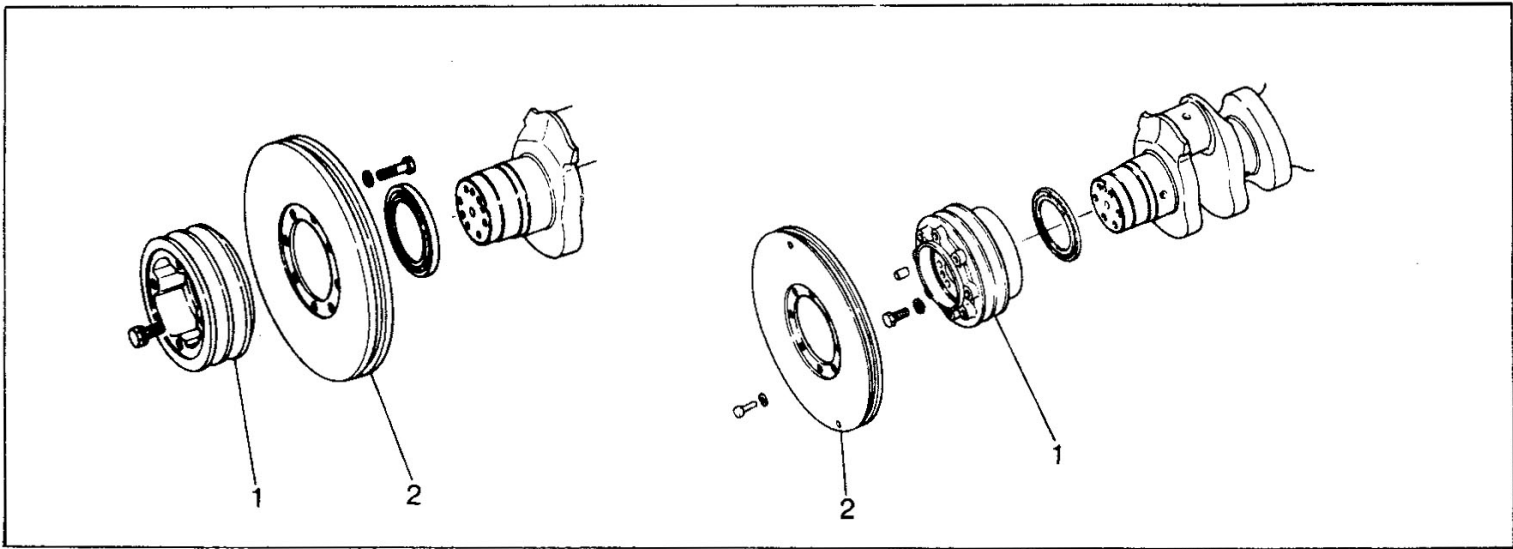

(3) Thermostat and Water Pump

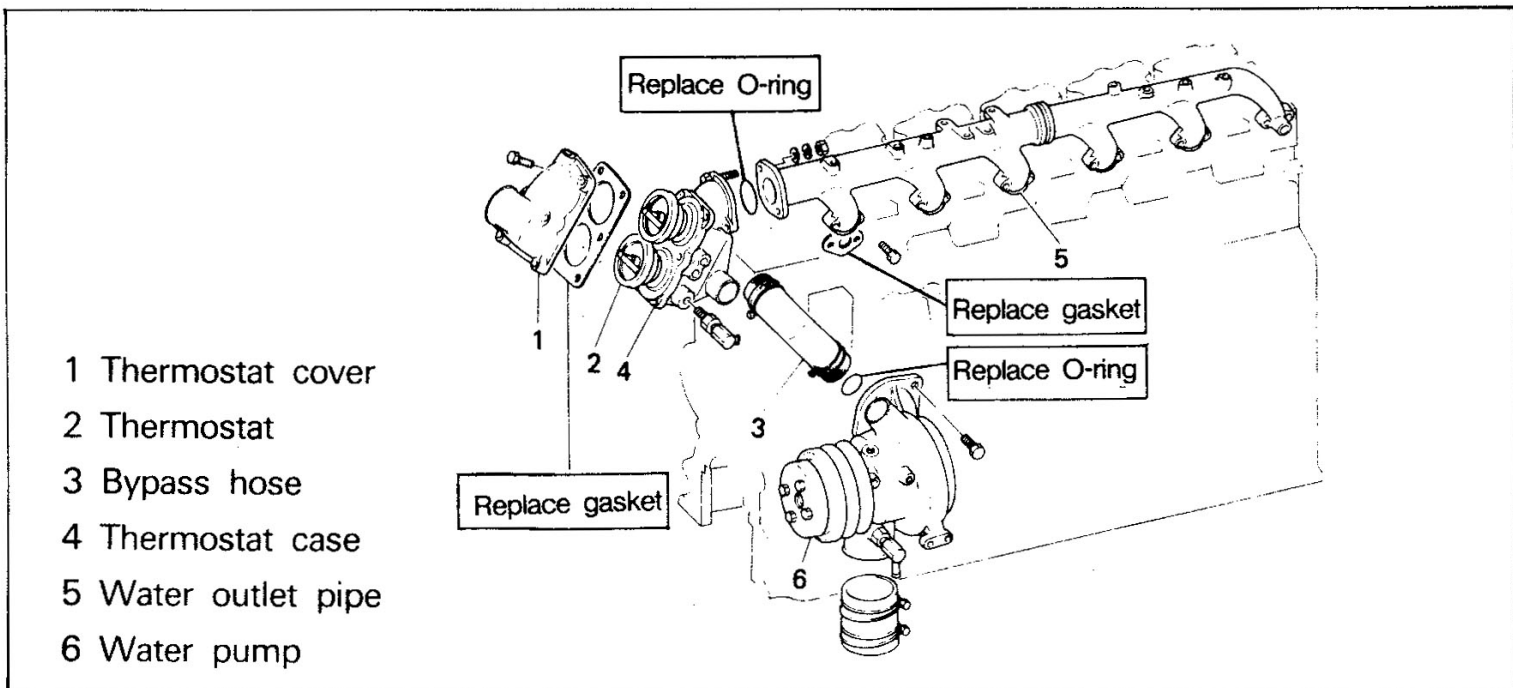

6-2-6 Lubrication

(1) Oil Filter and Oil Cooler

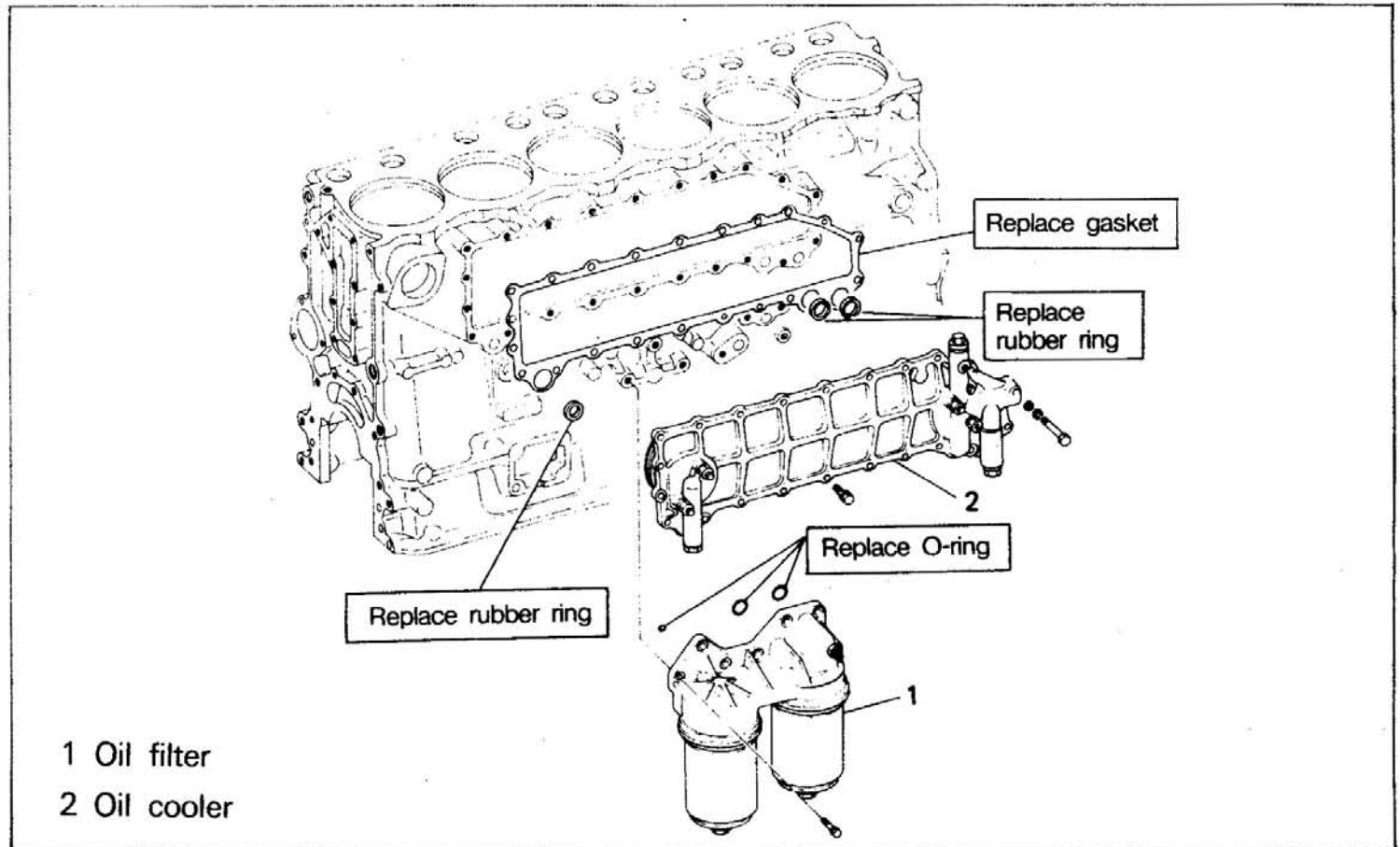

(2) Oil Pump and Oil Strainer

- | | |
|----------------|------------|
| 1 Oil pan | 3 Oil pipe |
| 2 Oil strainer | 4 Oil pump |

NOTE : 1. Before the oil pump is removed, measure the backlash.

2. The oil strainer and oil pipe should be removed as assembled with the oil pump, unless abnormal condition is evident.

3. After the oil pump has been installed, measure the backlash to confirm that the backlash is within the nominal values.

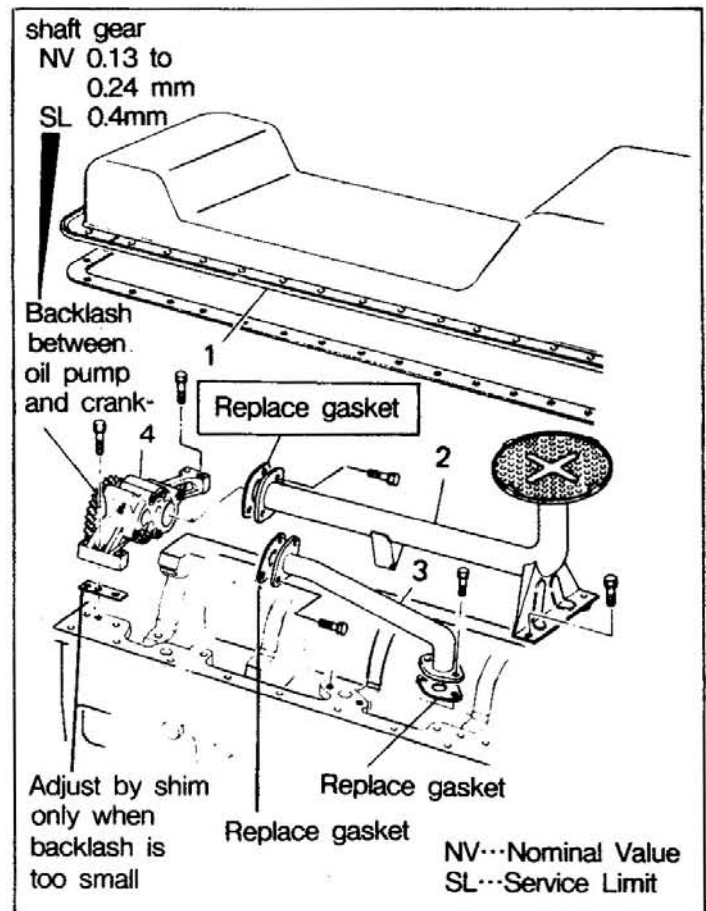

In servicing the engine proper, use the following tools and measuring instruments.

Special Tool Name	Part No.	Use
Valve Lifter	MH061668 MH061679	Removal and installation of inlet and exhaust valve cotters
Nozzle Tube Remover	MH061232	Removal of nozzle tube
Nozzle Tube Stamp	MH061229	Installation of nozzle tube
Nozzle Tube Installer Flange	MH061416	
Nozzle Tube Installer Bolt	MH061231	
Rocker Bushing Puller	MH061236	Removal and installation of rocker bushing
Valve Guide Puller	30091-08100	Removal and installation of valve guide
Caulking Tool, Exhaust	MH061651	Caulking of valve seat insert
Caulking Tool, Inlet	MH061650	
Valve Stem Seal Installer	ME067431	Installation of valve stem seal
Gear Puller	MH061061	Removal of gear and pulley
Piston Ring Tool	31191-02900	Removal and installation of piston ring
Piston Guide	31191-03200	Insertion of piston
Connecting Rod Bushing Puller	MH061238	Removal and installation of connecting rod bushing
Idler Gear Bushing Puller	MH061228	Removal and installation of idler gear bushing
Cylinder Liner Extractor	MH061490	Removal of cylinder liner
Cylinder Liner Installer	31191-03101	Installation of cylinder liner
Front Slinger Installer	MH061247	Installation of front slinger
Oil Seal Slinger Installer	MH061652	Installation of rear oil seal slinger
General tools and measuring instruments		
Snap ring pliers	Spring tester	Straight edge
Varnier calipers	Caliper gauge	Valve seat cutter
Portable jack	Thickness gauge	Dial gauge
Torque wrench	Connecting rod aligner	Square
Micrometer	Cylinder gauge	Valve lapper

7-1 DISASSEMBLY

This paragraph contains the procedures for disassembly of the engine proper with the engine auxiliaries removed. For removal and installation of the auxiliaries, refer to "Group 6 Removal and Installation of Auxiliaries."

For disassembly of the individual parts, the operational procedures aimed at their overhaul are shown, but the procedures are simply fundamental examples.

They may be changed as the occasion may demand.

As for the cylinder head and valve mechanism, the procedures for only one cylinder are shown. For the other cylinders, follow the same procedures.

When proceeding with disassembly operations, observe the following precautions.

- (1) Use proper tools suitable for disassembly operations to prevent damage.
- (2) For parts which might cause confusion at reassembly, make alignment marks on functionally safe points before disassembly.
- (3) The disassembled parts should be kept in order to prevent confusion. The parts independently assembled for each cylinder should be kept in a separate place to eliminate the possibility of their reinstallation in different positions.

7-1-1 Cylinder Head and Valve Mechanism

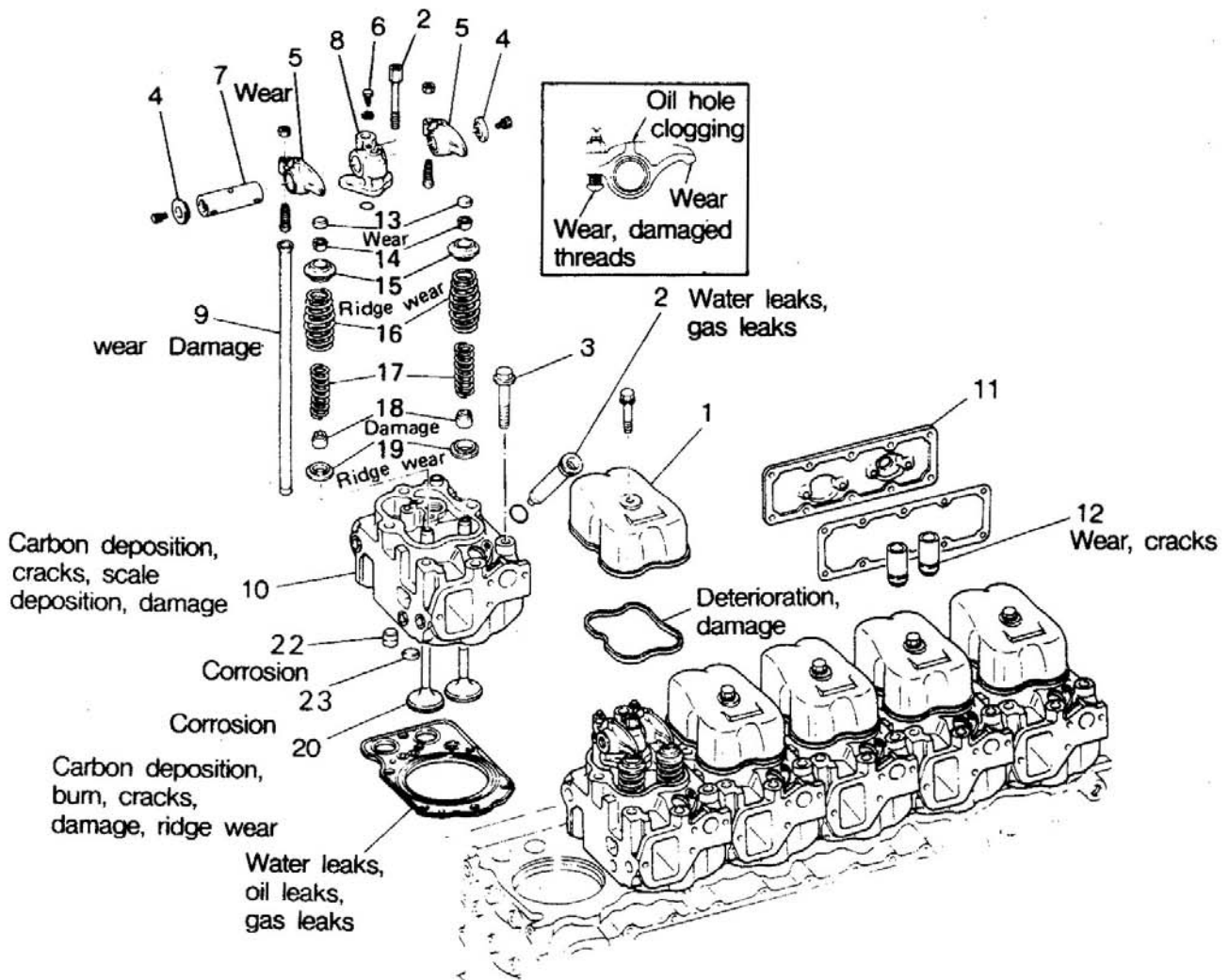

- | | |
|--------------------------------|-----------------------|
| 1 Rocker cover | 13 Valve cap |
| 2 Rocker bracket mounting bolt | 14 Valve cotter |
| 3 Cylinder head bolt | 15 Upper retainer |
| 4 Thrust plate | 16 Outer valve spring |
| 5 Rocker | 17 Inner valve spring |
| 6 Set screw | 18 Valve stem seal |
| 7 Rocker shaft | 19 Lower retainer |
| 8 Rocker shaft bracket | 20 Valve |
| 9 Push rod | 21 Nozzle tube |
| 10 Cylinder head | 22 Water director |
| 11 Crankcase side cover | 23 Sealing cap |
| 12 Tappet | |

(1) Remove the following parts.

- 1 Rocker cover
- 2 Rocker bracket mounting bolt
- 3 Cylinder head bolt

NOTE : Where the push rod is forcing the rocker up, the rocker adjusting screws should be loosened before all bolt are removed.

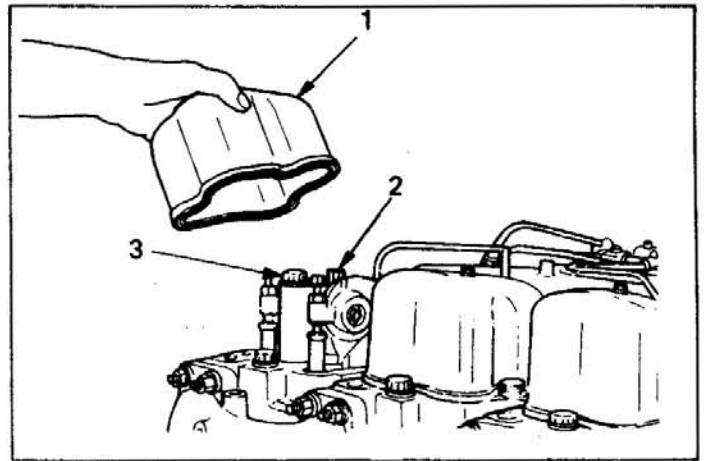

(2) Remove the rocker shaft bracket assembly from the cylinder head.

NOTE : The rocker shaft bracket assembly is set in position on the cylinder head by spring pins.

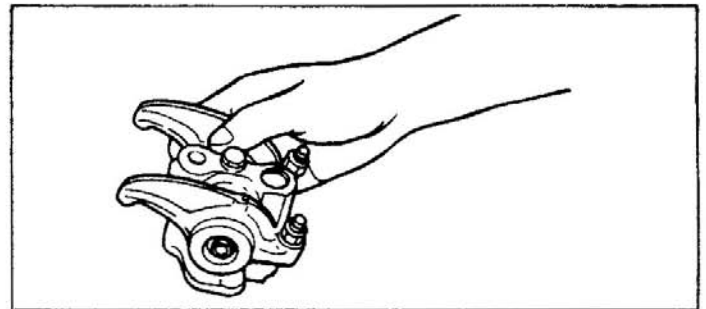

(3) Remove the following parts.

- 4 Thrust plate
- 5 Rocker
- 6 Set screw
- 7 Rocker shaft
- 8 Rocker shaft bracket

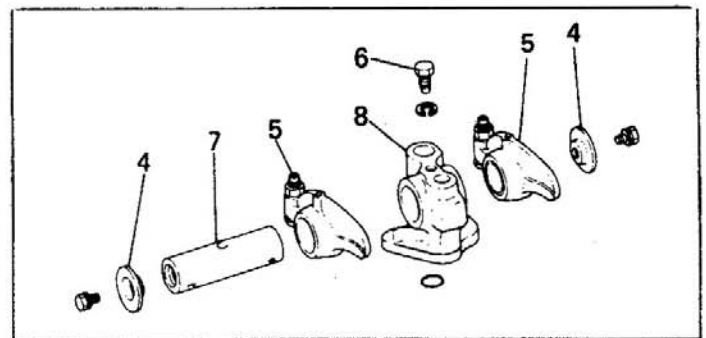

(4) Withdraw the push rod 9 and remove the cylinder head 10 from the crankcase.

NOTE : 1. To remove the cylinder head, make sure that the injection nozzle is removed beforehand. If the cylinder head with nozzle mounted is placed on the work table, damage to the nozzle end projecting from the bottom surface of the cylinder head will result.

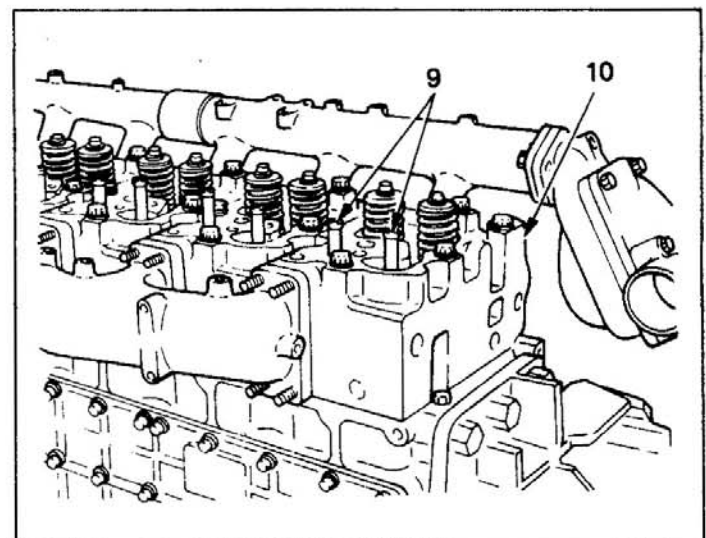

2. When the cylinder head gasket is removed, make sure that the cylinder head and crankcase are not scratched.
3. Since the cylinder head is located by dowel pins on the top surface of the crankcase, make sure that the cylinder head is lifted straight upward when removed.

- (5) Remove the crankcase side cover 11 and remove the tappet 12 from the crankcase.

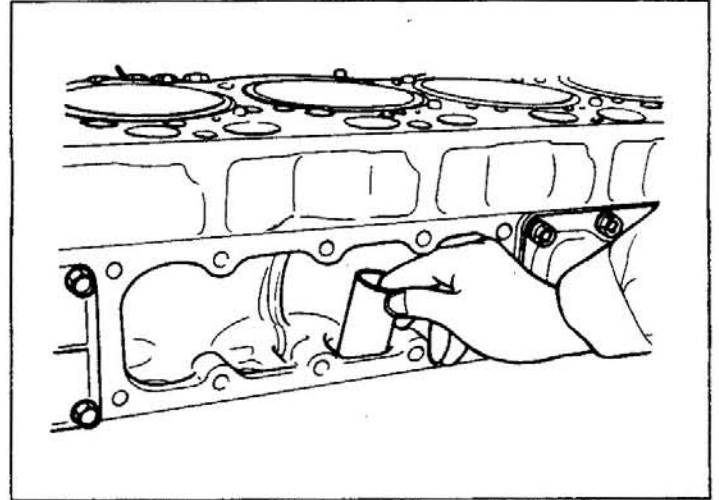

- (6) Remove the valve cap 13. Using Valve Lifter (special tool) as shown, remove the valve cotter 14.

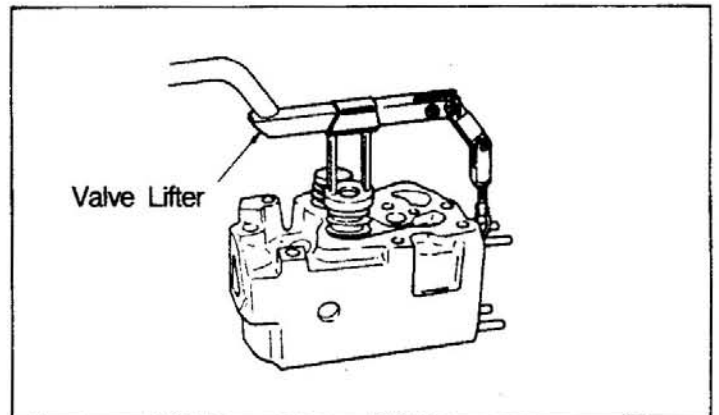

NOTE : Make sure that the valve spring is evenly compressed.

- (7) Remove the following parts.

- 15 Upper retainer
- 16 Outer valve spring
- 17 Inner valve spring
- 18 Valve stem seal
- 19 Lower retainer
- 20 Valve

NOTE : When the valve stem seal was removed, make sure that a new one is installed.

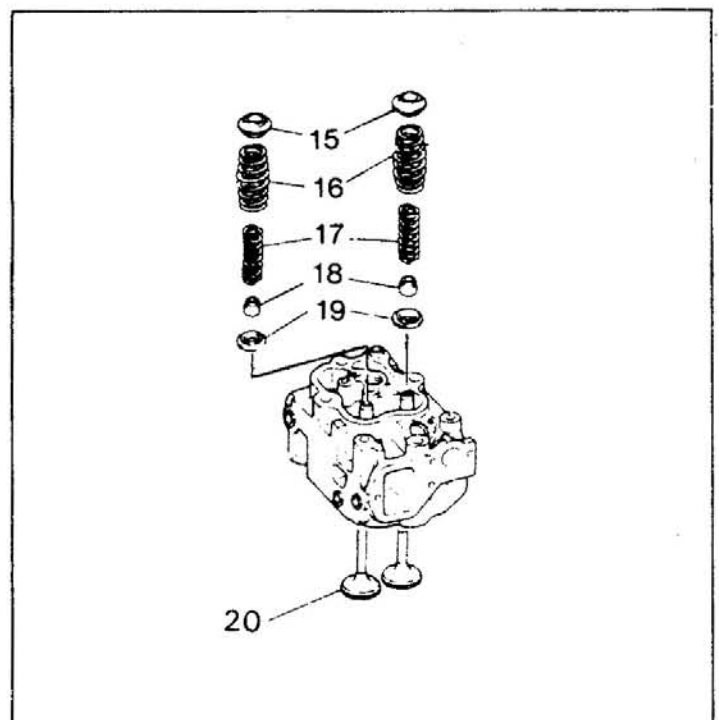

- (8) Withdraw the nozzle tube 21 with Nozzle Tube Remover(special tool).

NOTE : The nozzle tube need not be removed unless water leaks, gas leaks, etc. are evident.

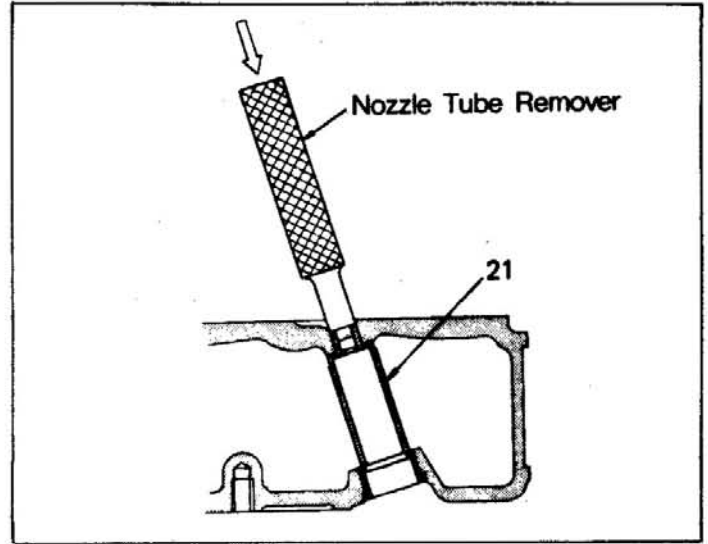

- (9) If the water director 22 and sealing cap 23 are corroded, withdraw.

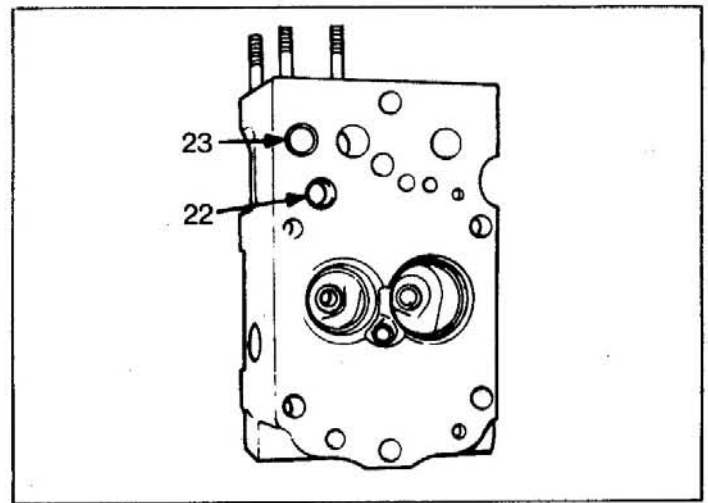

7-1-2 Flywheel, Timing Gear and Camshaft

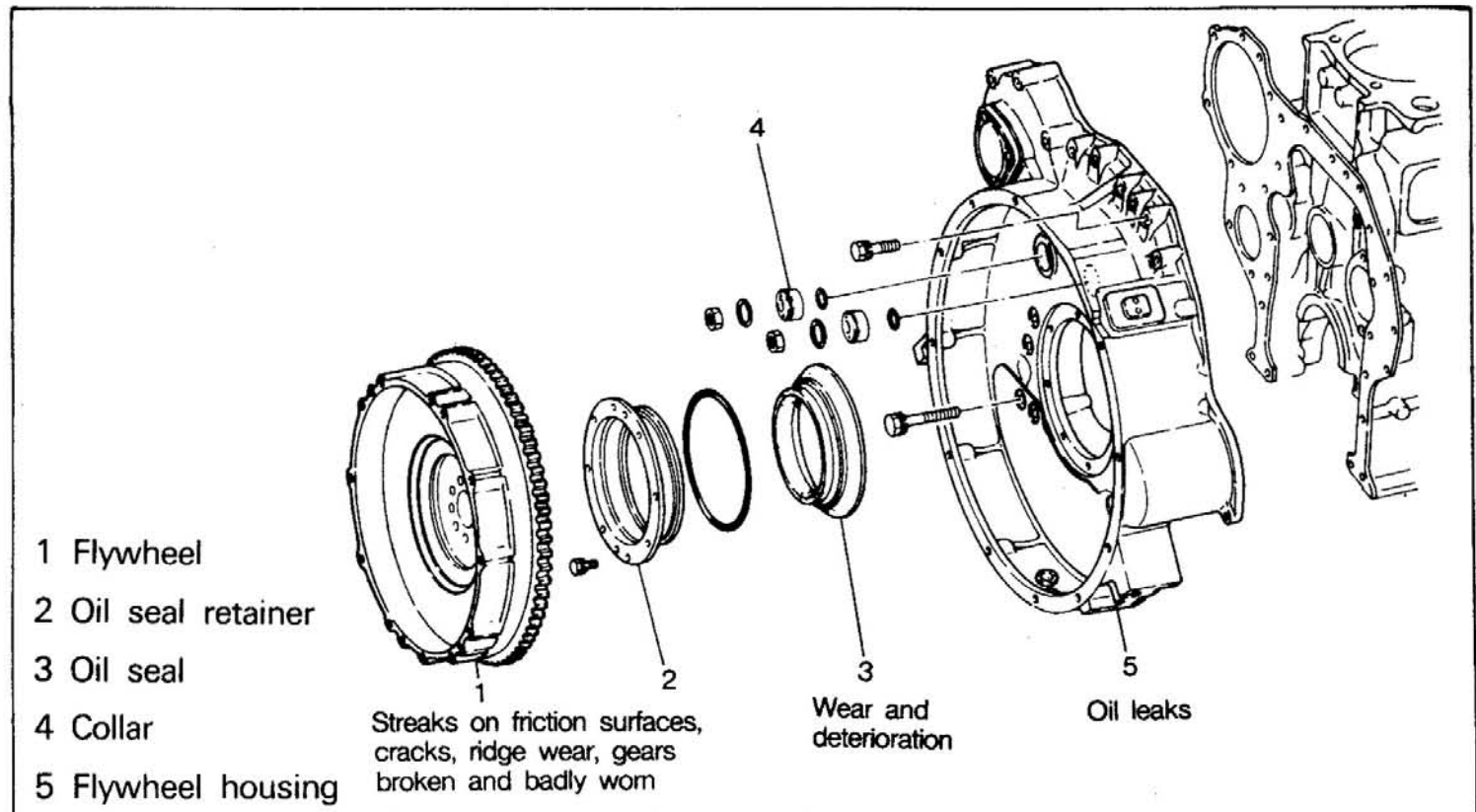

Timing gear backlash
 Crankshaft gear-idler gear "B"
 NV 0.12 to 0.26 mm
 SL 0.4 mm
 Idler gear "A"-camshaft gear
 NV 0.11 to 0.23 mm
 SL 0.4 mm
 Idler gear "A"-idler gear "C"
 NV 0.11 to 0.24 mm
 SL 0.4 mm
 Injection pump gear-idler gear "C"
 NV 0.12 to 0.25 mm
 SL 0.4 mm
 Power steering gear-idler gear "C"
 NV 0.10 to 0.23 mm
 SL 0.4 mm

NV...Nominal Value
 RL...Repair Limit
 SL...Service Limit

Idler gear end play
 NV 0.1 to 0.28 mm
 RL 0.4 mm

Camshaft gear end play
 NV 0.05 to 0.22 mm
 RL 0.4 mm

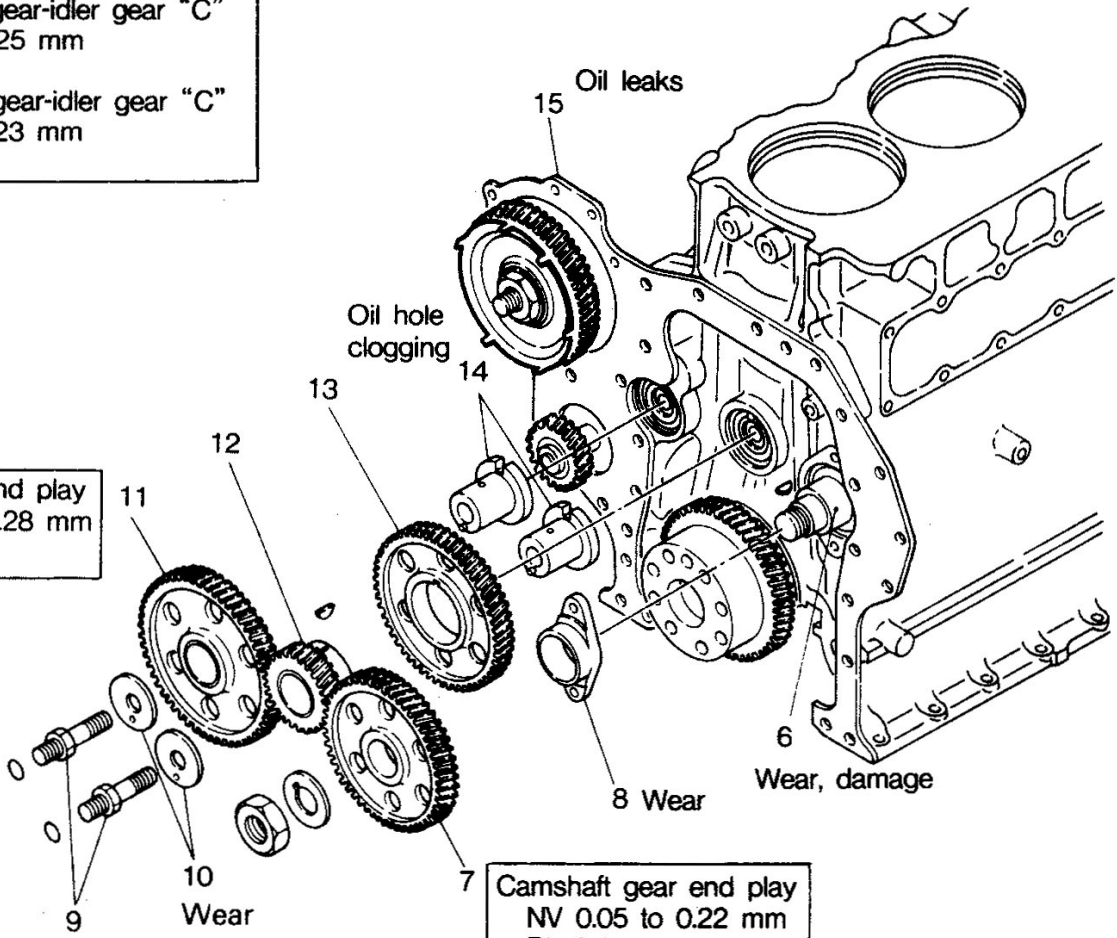

- | | |
|--------------------|-------------------|
| 6 Camshaft | 11 Idler gear "C" |
| 7 Camshaft gear | 12 Idler gear "A" |
| 8 Thrust plate | 13 Idler gear "B" |
| 9 Idler shaft bolt | 14 Idler shaft |
| 10 Thrust plate | 15 Rear plate |

- (1) Thread the mounting bolt into the removing threaded hole to remove the flywheel 1.

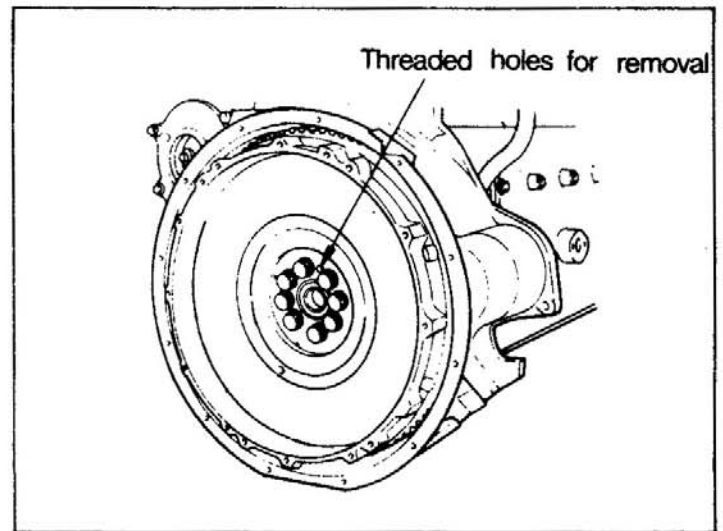

- (2) Remove the following parts.

- 2 Oil seal retainer
- 3 Oil seal
- 4 Collar
- 5 Flywheel housing

Remove the oil seal retainer with oil seal attached by threading the mounting bolts evenly into the removing threaded holes.

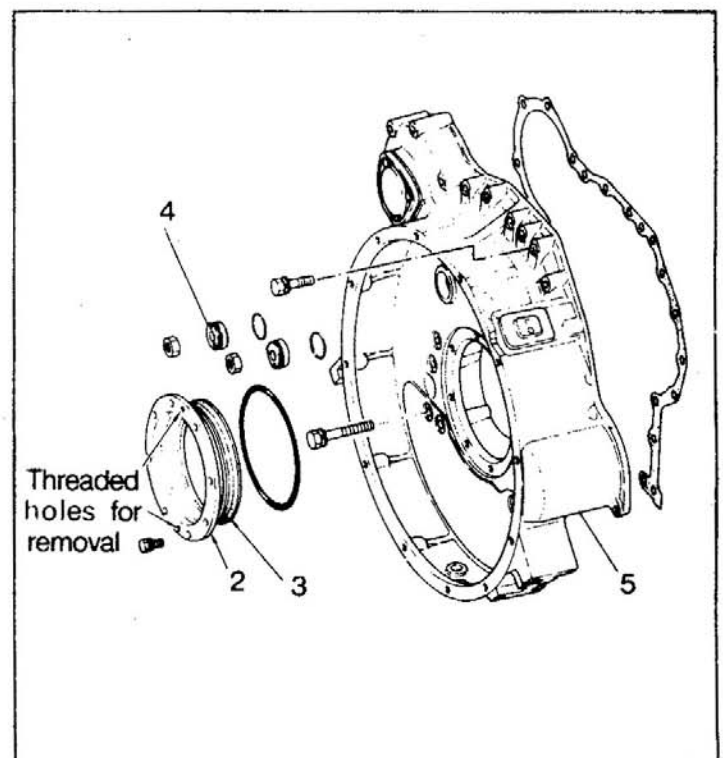

NOTE : Do not remove the pointer mounted to the inspection window of the flywheel housing.

- (3) Measure the backlash between the individual gears. Parts that have exceeded the service limit should be replaced.

NOTE : For a pair of gears, the backlash should be measured at more than three points to determine whether it is acceptable.

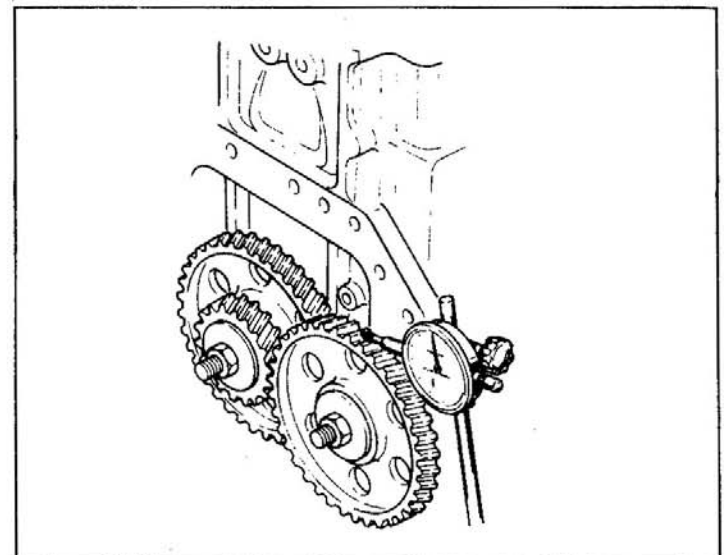

- (4) Measure the idler gear and camshaft gear end plays with a thickness gauge and dial indicator. If the readings are over the repair limit, replace the thrust plate.

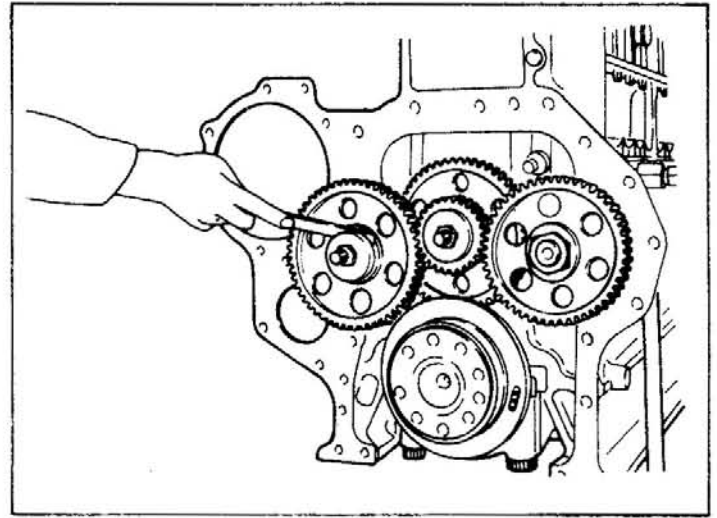

- (5) Loosen the thrust plate mounting bolt through the camshaft gear hole and remove the camshaft 6.

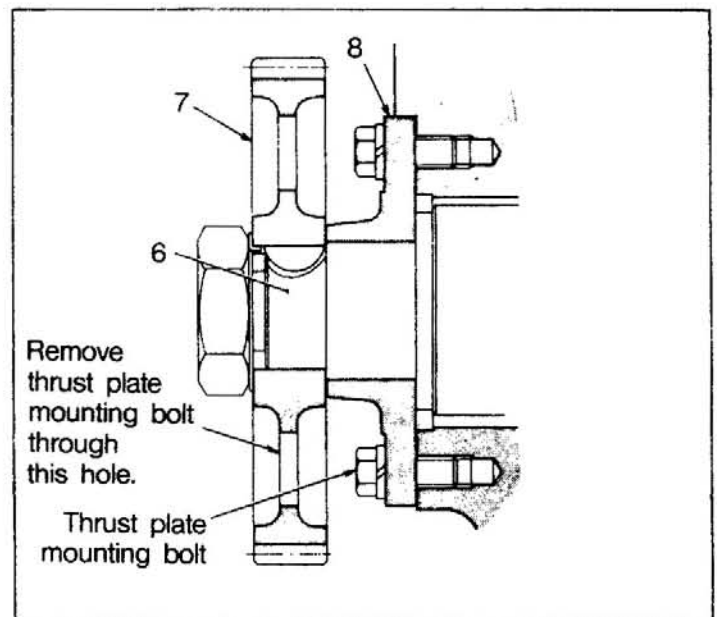

- (6) Remove the lock nut and lock washer of the camshaft gear and withdraw the camshaft gear 7 with Gear Puller (special tool).

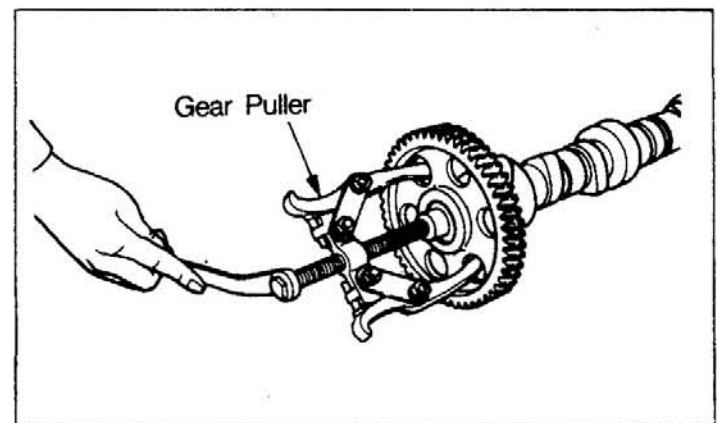

Remove the thrust plate 8.

NOTE : 1. Do not remove the gears unless trouble is evident.

2. Do not strike the gears with a hammer. Make sure that the gears are removed by use of a gear puller.

(7) Remove the following parts.

- 9 Idler shaft bolt
- 10 Thrust plate
- 11 Idler gear "C"
- 12 Idler gear "A"
- 13 Idler gear "B"
- 14 Idler shaft

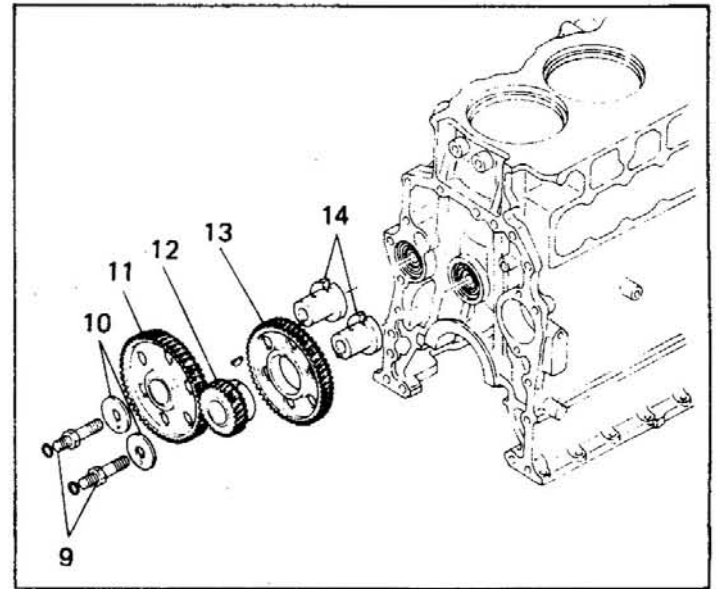

7-1-3 Crankcase and Main Moving Parts

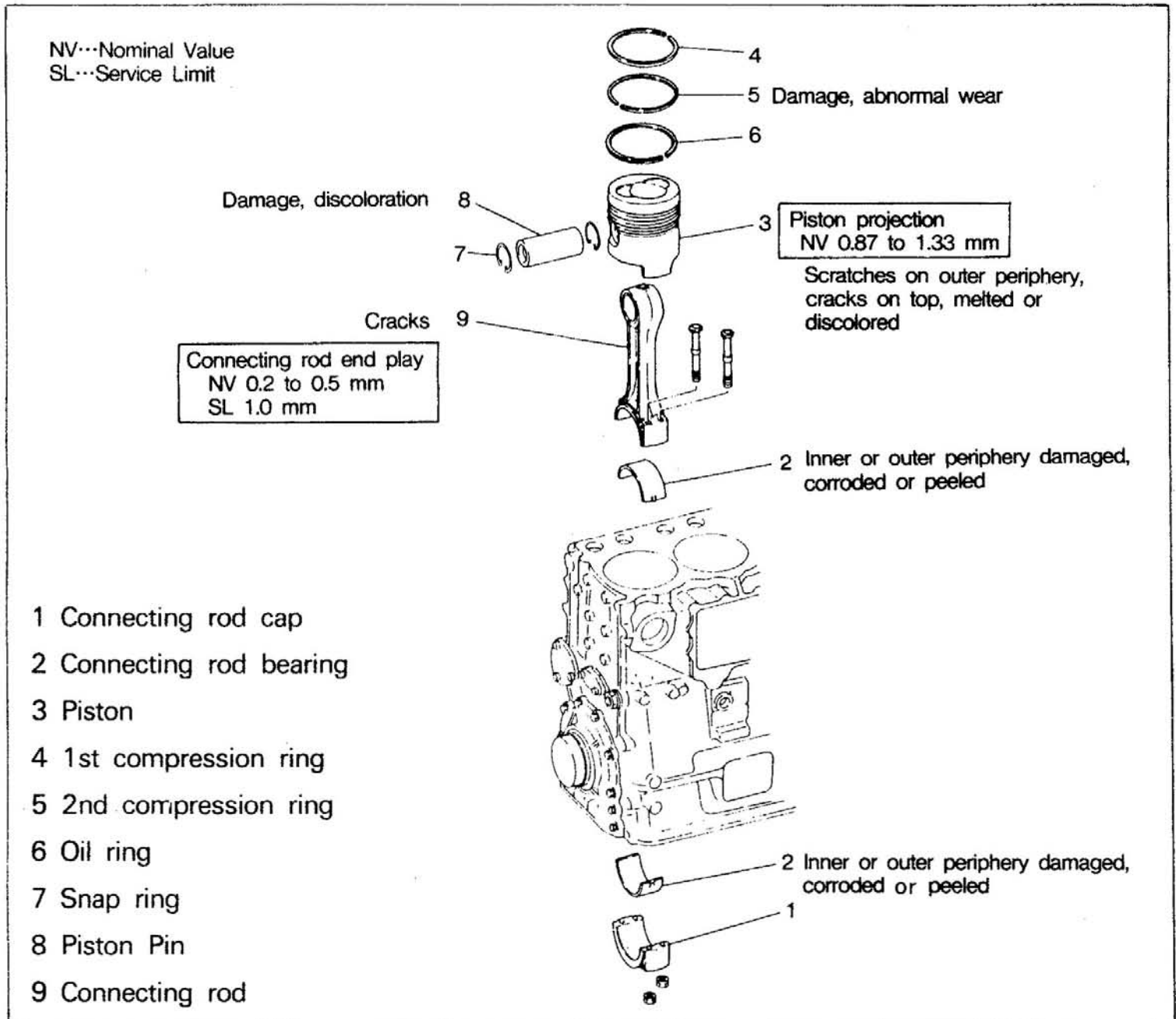

NV...Nominal Value
 RL...Repair Limit

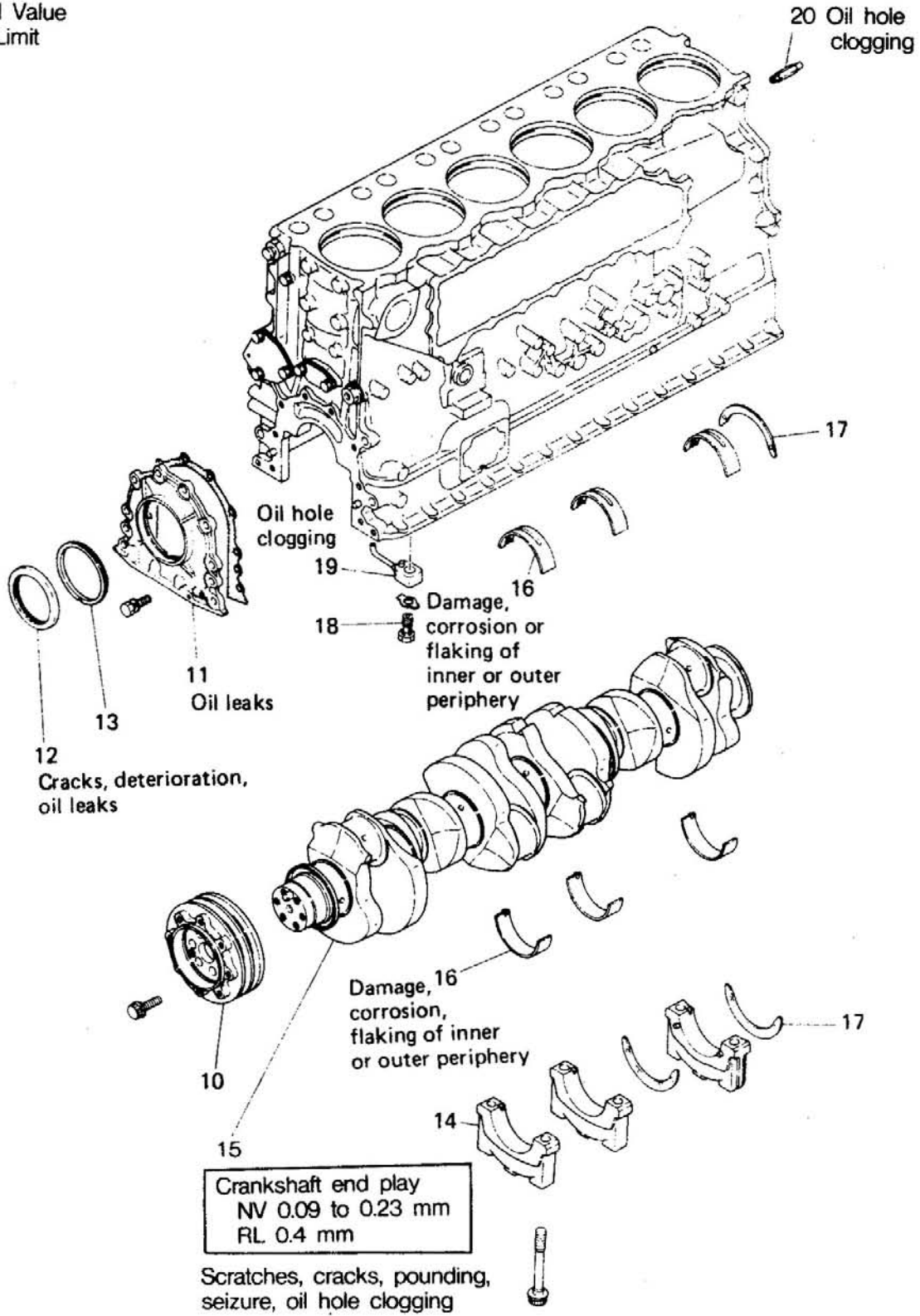

- 10 Crankshaft pulley
- 11 Front cover
- 12 Oil seal
- 13 Seal plate
- 14 Main bearing cap
- 15 Crankshaft

- 16 Main bearing
- 17 Thrust plate
- 18 Check valve
- 19 Oil jet
- 20 Oil spray plug

(1) Measure the projection of each piston by the following procedures. If the readings are out of specification, check all clearances.

- (a) Hold the dial indicator to the top surface of the crankcase and make zero adjustment.
- (b) Find the top dead center of piston with a dial indicator.
- (c) Measure three points on the top surface of piston to find the average value.

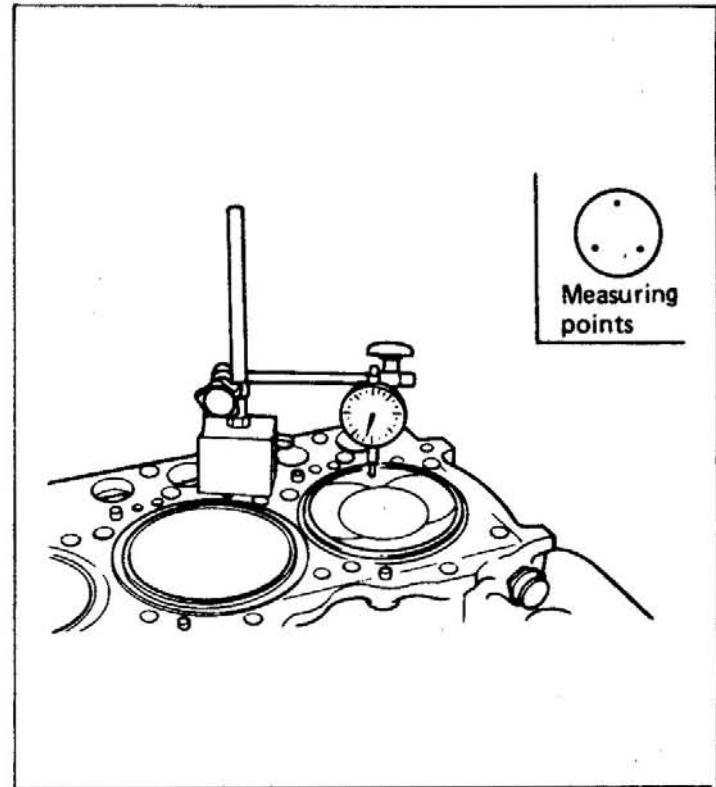

NOTE : Make sure that the piston projection is up to specification, because an incorrect projection could cause adverse effects on engine performance.

(2) Measure the end play of each connecting rod. If the service limit is exceeded, replace the connecting rod.

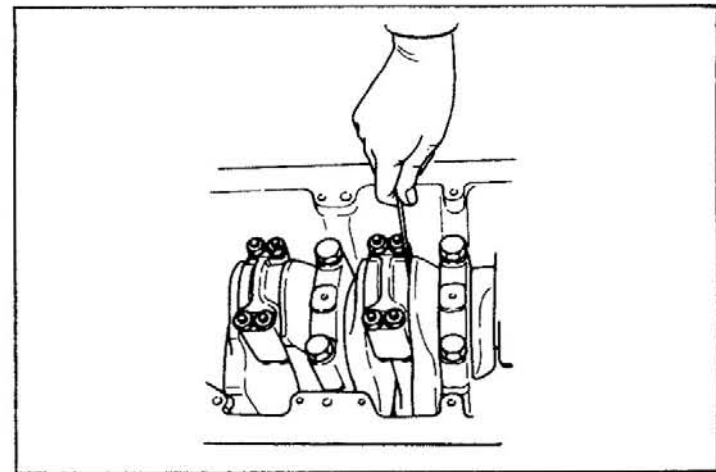

(3) Remove the following parts.

- 1 Connecting rod cap
- 2 Connecting rod bearing
- 3 Piston

NOTE : When withdrawing the piston from the crankcase by pushing up together with the connecting rod use care to prevent damage to the cylinder liner.

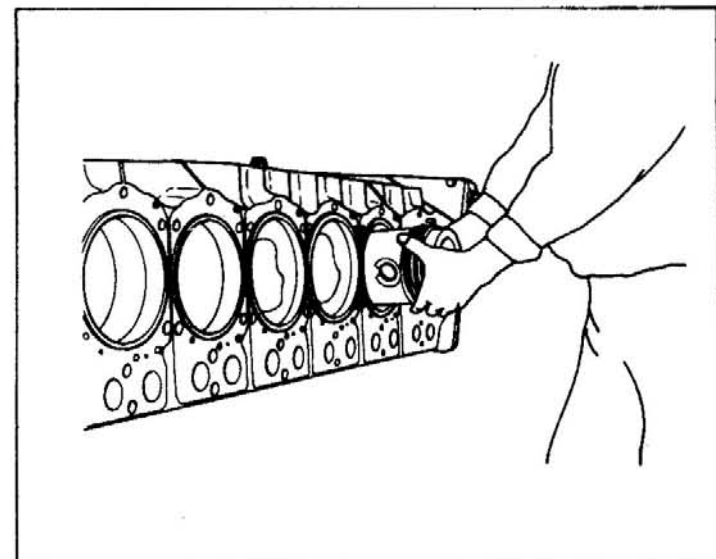

(4) Remove the piston rings, using piston Ring Tool(special tool).

- 4 1st compression ring
- 5 2nd compression ring
- 6 Oil ring

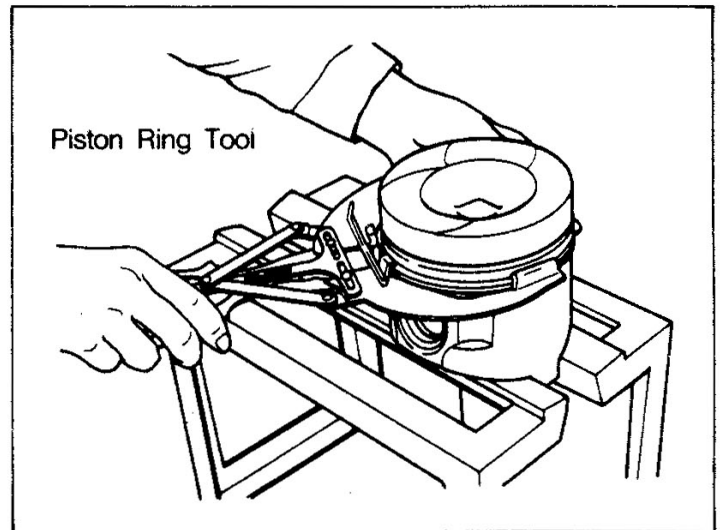

(5) Remove the following parts.

- 7 Snap ring
- 8 Piston pin
- 9 Connecting rod

If the piston pin is hard to remove, heat it with a piston heater or in hot water.

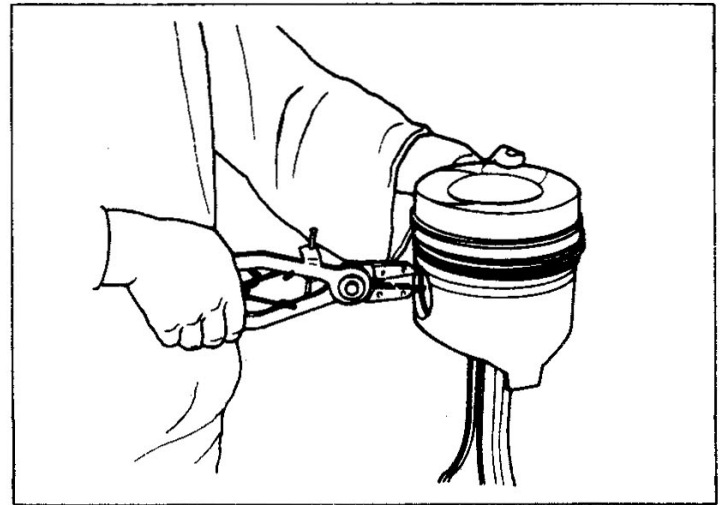

(6) Measure the end play of crankshaft. If the reading is in excess of the repair limit, replace the thrust plate with an oversize one.

There are three kinds of oversize thrust plates ; +0.15, +0.30 and +0.45mm.

The thrust plates on both sides of the bearing cap need not be the same size. However, the thrust plate on the rear end of the crankcase and the one on the rear side of the bearing cap must be the same size.

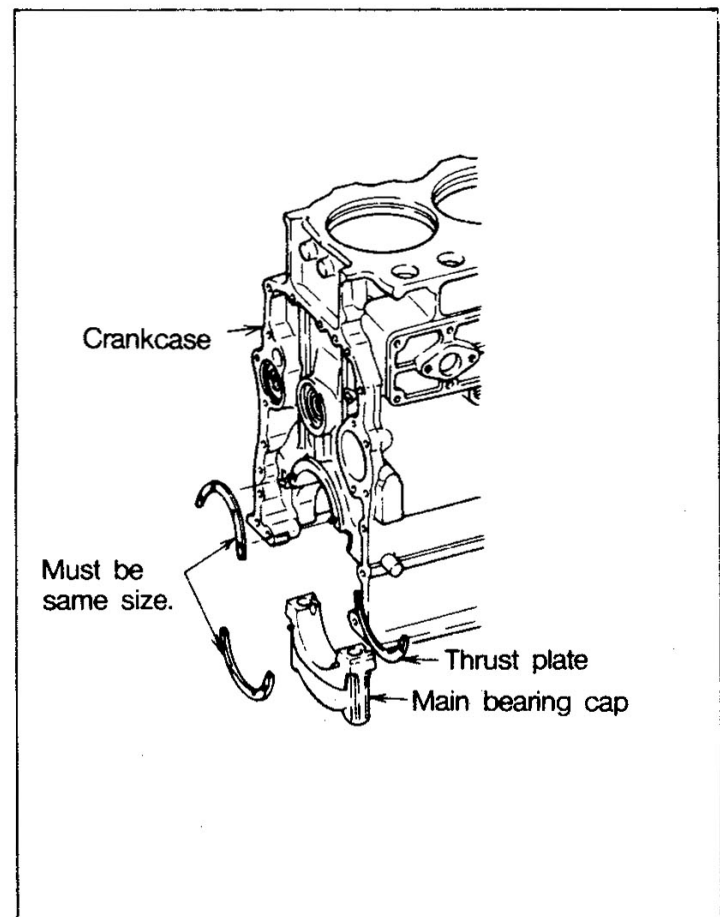

(7) Remove the following parts.

10 Crankshaft pulley

11 Front cover

The crankshaft pulley should be removed by threading the removed bolt into the removing threaded hole.

NOTE : The oil seal 12 and seal plate 13 need not be removed unless trouble is evident.

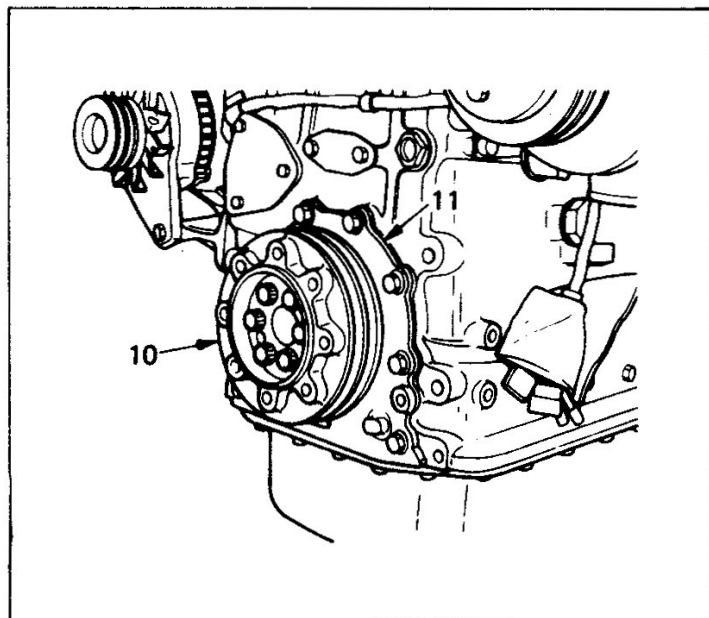

(8) Remove the following parts.

14 Main bearing cap

15 Crankshaft

16 Main bearing

17 Thrust plate

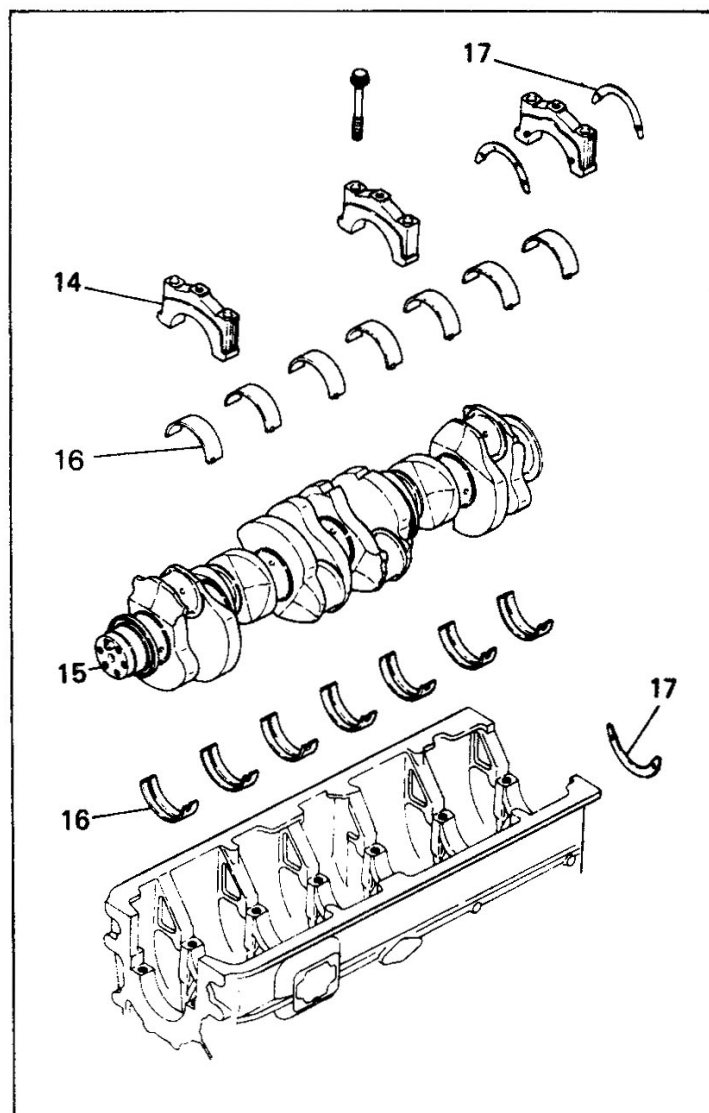

(9) Remove the following parts.

18 Check valve

19 Oil jet

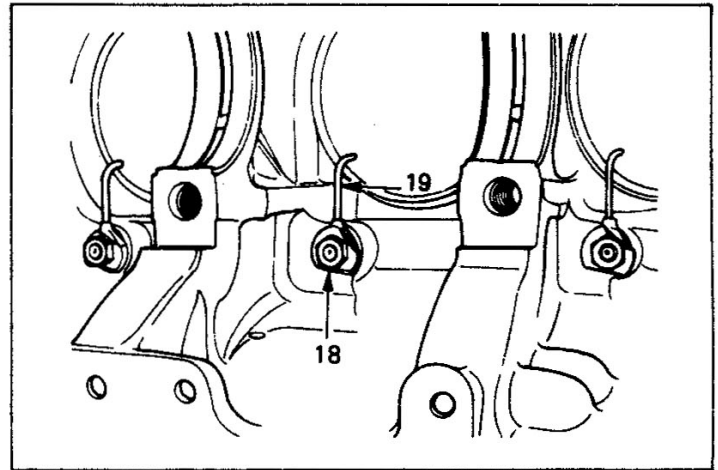

(10) Remove the oil spray plug 20 and check to ensure that the oil hole is not clogged.

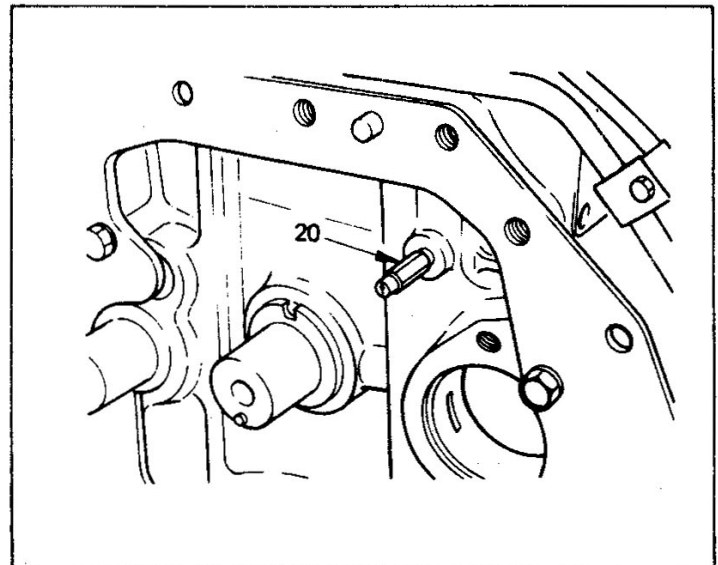

7-2 INSPECTION AND CORRECTION

BD...Basic Diameter
 NV...Nominal Value
 RL...Repair Limit
 SL...Service Limit

Clearance
 BD 28 mm
 NV 0.03 to 0.08 mm
 RL 0.2 mm

Free length
 NV 73.46 mm
 SL 70.5 mm
 Load/installed length
 NV 325 N (33 kgf)/58.35 mm
 SL 275 N (28 kgf)/58.35 mm
 Squareness
 SL 2.5 mm

Displacement
 SL 0.5 mm

Free length
 NV 65.04 mm
 SL 62.0 mm
 Load/installed length
 NV 120 N (12 kgf)/50.35 mm
 SL 100 N (10.2 kgf)/50.35 mm
 Squareness
 SL 2.5 mm

Crankcase tappet hole to
 tappet clearance
 BD 35 mm
 NV 0.06 to 0.10 mm
 SL 0.2 mm

Valve stem O.D Inlet valve NV 11.95 to 11.96 mm SL 11.85 mm	Exhaust valve NV 11.91 to 11.93 mm SL 11.85 mm	Valve margin Inlet NV 2.2 mm SL 1.7 mm	Exhaust NV 2.5 mm SL 2.0 mm
Valve guide to valve stem clearance Inlet valve BD 12 mm NV 0.05 to 0.09 mm SL 0.2 mm	Exhaust valve BD 12 mm NV 0.09 to 0.12 mm SL 0.2 mm	Sinkage of valve from bottom surface of cylinder head Inlet valve NV 0.25 to 0.75 mm SL 1.0 mm	Exhaust valve NV -0.05 to 0.45 mm SL 0.7 mm
Valve seat insert seat width NV 2.69 to 2.96 mm RL 3.5 mm	Distortion of cylinder head bottom surface NV 0.07 mm RL 0.08 mm		

NV...Nominal Value
RL...Repair Limit

Distortion of friction surface
NV 0.1 mm or less
RL 0.2 mm

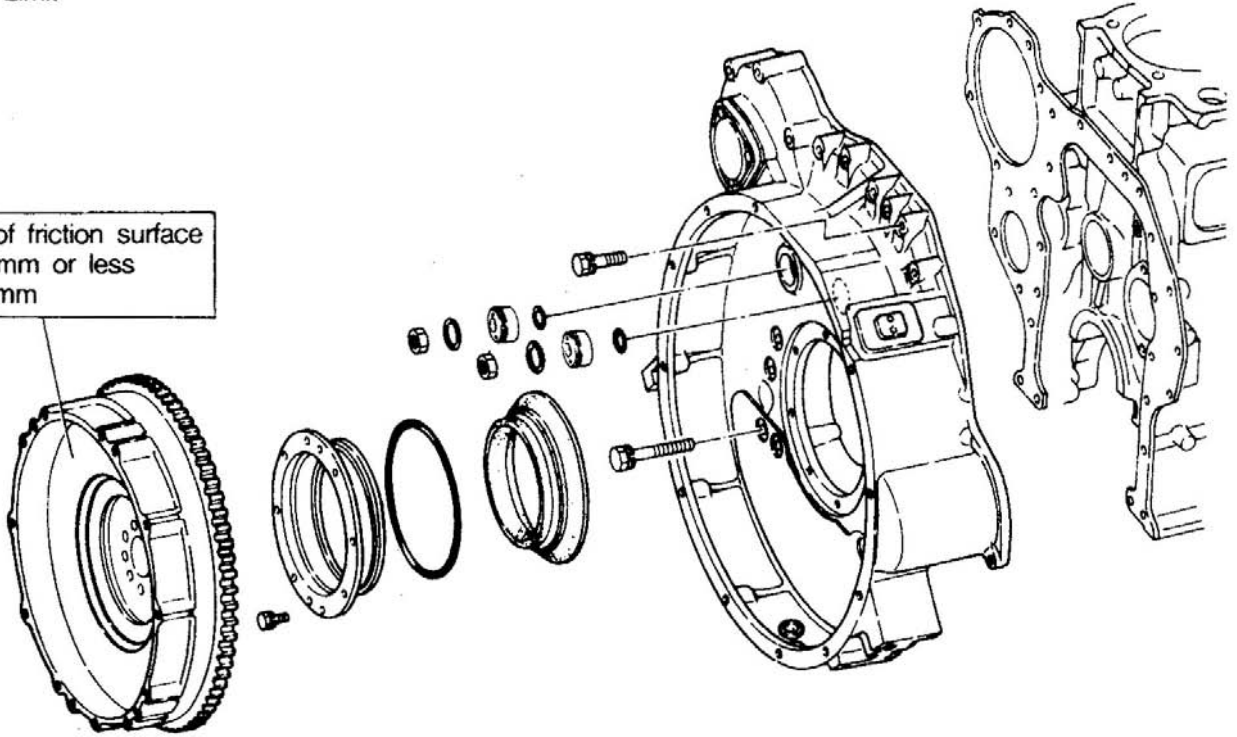

BD...Basic Diameter
 NV...Nominal Value
 RL...Repair Limit
 SL...Service Limit

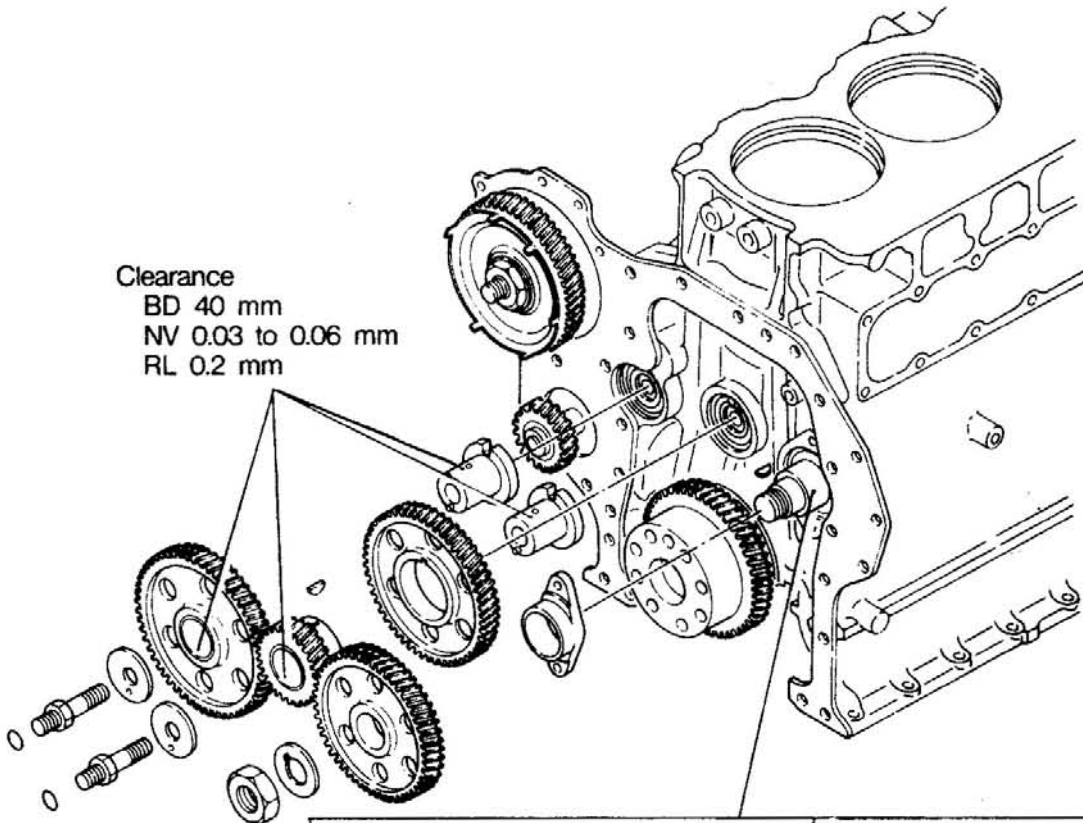

Clearance
 BD 40 mm
 NV 0.03 to 0.06 mm
 RL 0.2 mm

Cam profile
 (difference between
 lobe height and base
 circle diameter)
 BD
 (intake valve cam)
 Lobe height 56.167 mm
 Base circle diameter 47.334 mm
 (exhaust valve cam)
 Lobe height 56.036 mm
 Base circle diameter 47.216 mm

Camshaft journal to
 bushing clearance
 BD No. 1 65.00 mm
 No. 2 65.25 mm
 No. 3, 4 65.50 mm
 No. 5, 6 65.75 mm
 No. 7 66 mm
 NV 0.03 to 0.08 mm
 RL 0.25 mm

Bend
 NV 0.05mm or less
 RL 0.08mm

BD...Basic Diameter
 NV...Nominal Value
 RL...Repair Limit
 SL...Service Limit

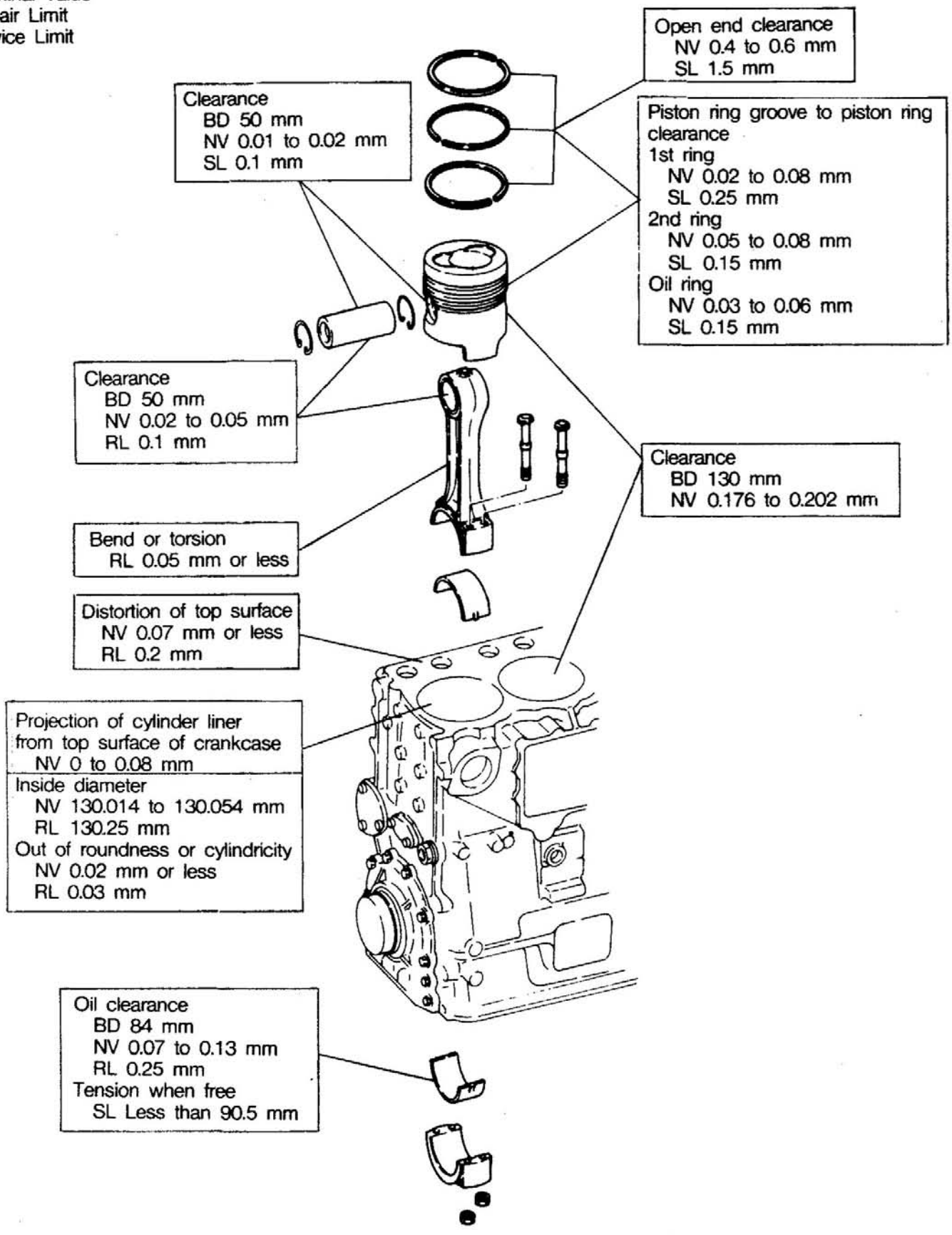

Clearance
 BD 50 mm
 NV 0.01 to 0.02 mm
 SL 0.1 mm

Open end clearance
 NV 0.4 to 0.6 mm
 SL 1.5 mm

Piston ring groove to piston ring clearance
 1st ring
 NV 0.02 to 0.08 mm
 SL 0.25 mm
 2nd ring
 NV 0.05 to 0.08 mm
 SL 0.15 mm
 Oil ring
 NV 0.03 to 0.06 mm
 SL 0.15 mm

Clearance
 BD 50 mm
 NV 0.02 to 0.05 mm
 RL 0.1 mm

Clearance
 BD 130 mm
 NV 0.176 to 0.202 mm

Bend or torsion
 RL 0.05 mm or less

Distortion of top surface
 NV 0.07 mm or less
 RL 0.2 mm

Projection of cylinder liner from top surface of crankcase
 NV 0 to 0.08 mm
 Inside diameter
 NV 130.014 to 130.054 mm
 RL 130.25 mm
 Out of roundness or cylindricity
 NV 0.02 mm or less
 RL 0.03 mm

Oil clearance
 BD 84 mm
 NV 0.07 to 0.13 mm
 RL 0.25 mm
 Tension when free
 SL Less than 90.5 mm

BD...Basic Diameter
 NV...Nominal Value
 RL...Repair Limit
 SL...Service Limit

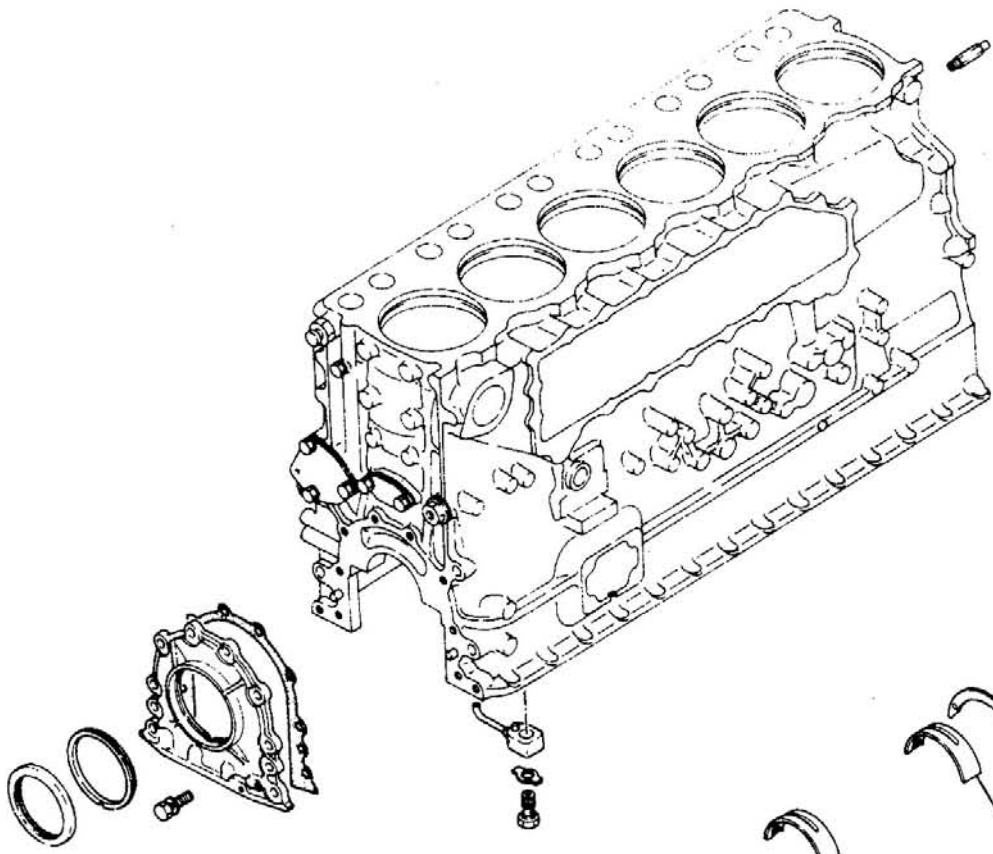

	Out of roundness NV 0.01 mm or less RL 0.08 mm
Bend NV 0.04 mm or less RL 0.1 mm	Cylindricity NV 0.006 mm or less

Oil clearance BD 100 mm NV 0.08 to 0.15 mm RL 0.25 mm
--

Tension
 when free
 SL Less than
 106.5 mm

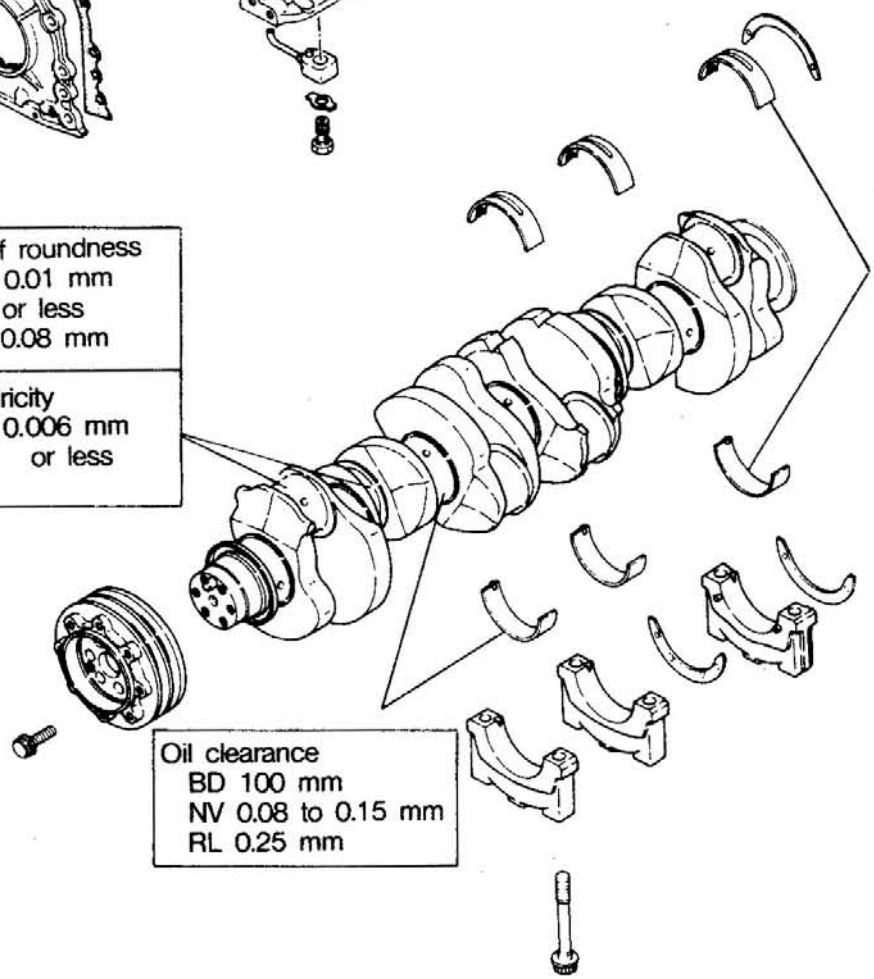

7-2-1 Valve Mechanism

- (1) Calculate the clearance from the rocker I.D. and rocker shaft O.D. If the repair limit is exceeded, replace the bushing in the rocker.

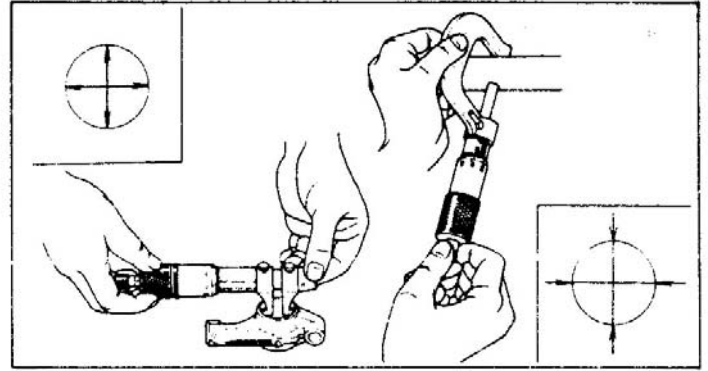

- (2) Replacement of Rocker Bushing

Replace the bushing by the procedures shown in illustration, using Rocker Bushing Puller (special tool).

- NOTE :
1. Align the bushing and rocker oil holes.
 2. Face the bushing joint toward the adjusting screw.

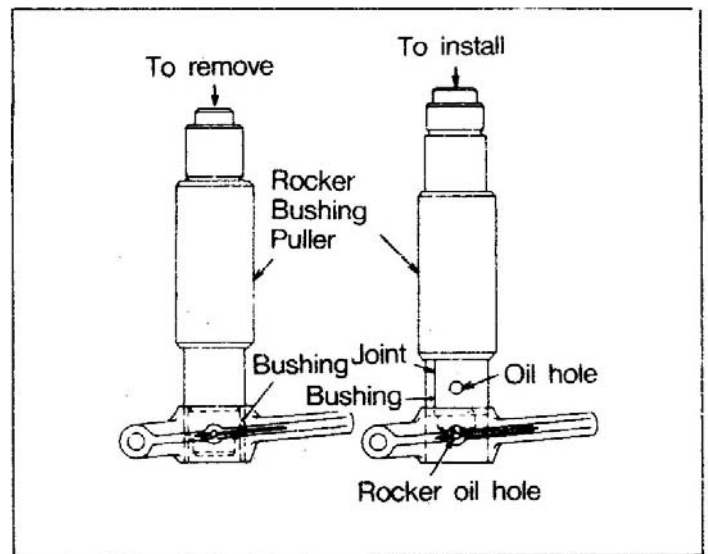

- (3) Measure the displacement, free length, and installed length/load of the valve spring. If the service limit is exceeded, replace.

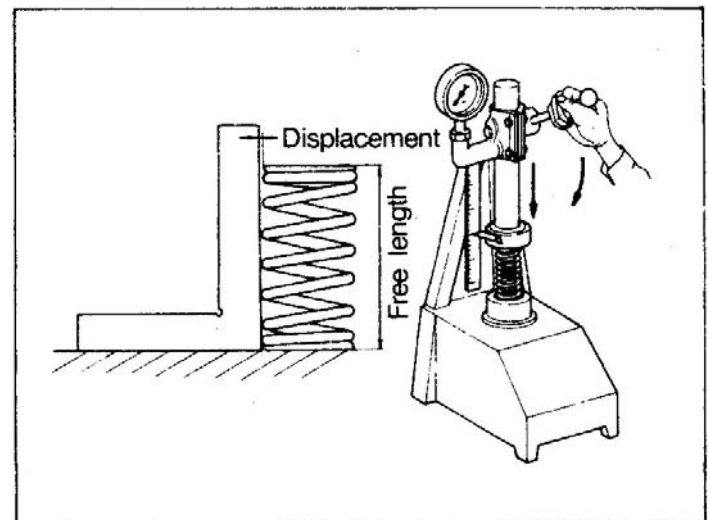

- (4) Measure the clearance from the tappet O.D. and crankcase I.D. If the service limit is exceeded, replace the tappet.

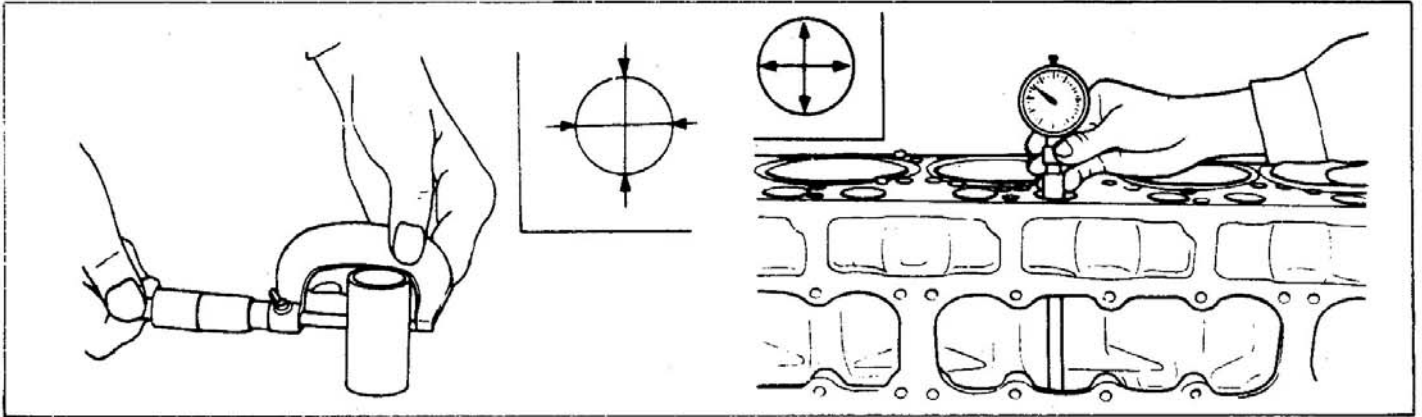

- (5) Measure the push rod runout. If the service limit is exceeded, replace.

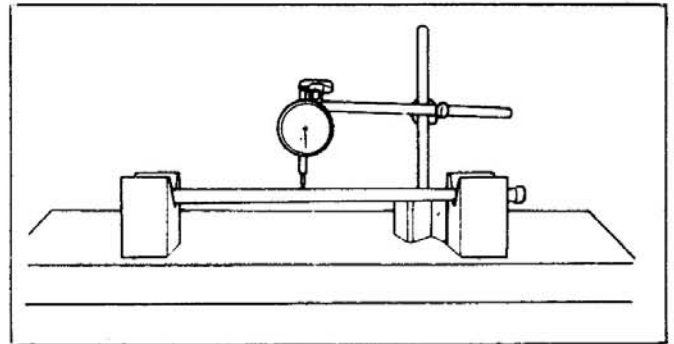

7-2-2 Cylinder Head, Valve and Valve Seat Insert

- (1) Measure the cylinder head bottom surface distortion. If the repair limit is exceeded, correct the distortion with a surface grinder.

NOTE : The height from the top to bottom surface of the cylinder head after grinding must be more than 129.8mm.

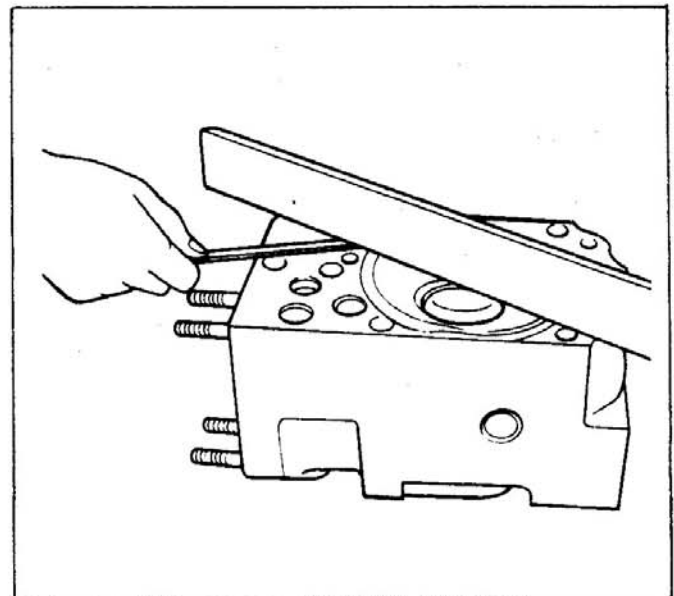

- (2) Measure the valve stem O.D. If it is smaller than the service limit, replace.

An excessively unevenly worn stem should also be replaced.

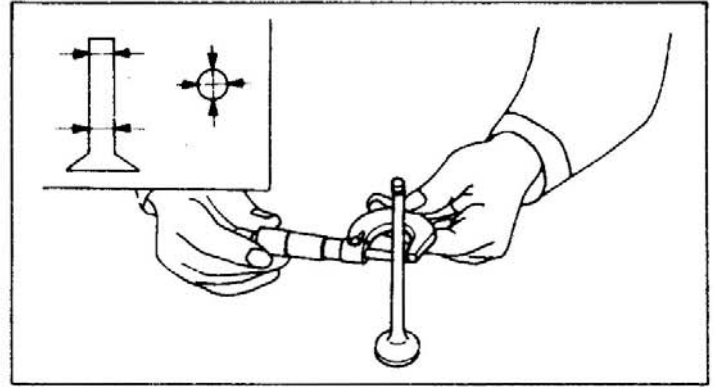

- (3) Calculate the clearance from the valve guide I.D. and valve stem O.D. If the service limit is exceeded, replace the valve guide.

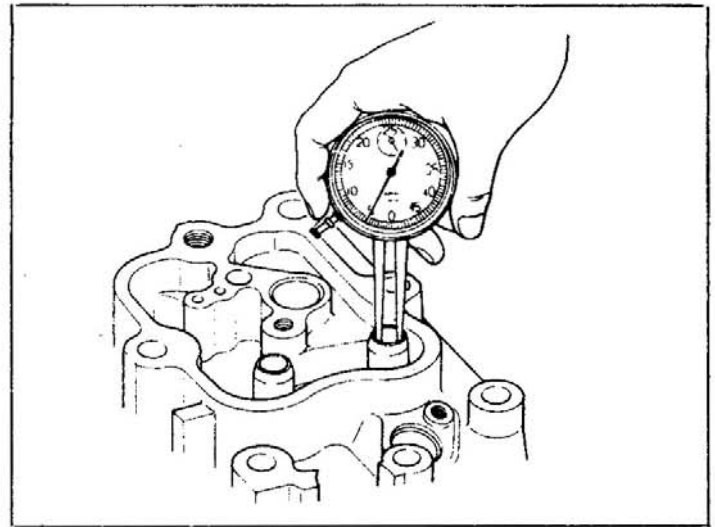

- (4) Replacement of Valve Guide

Using Valve Guide Puller (special tool), replace the valve guide.

NOTE : When the valve guide is installed, make sure that the valve guide flange is securely seated on the cylinder head.

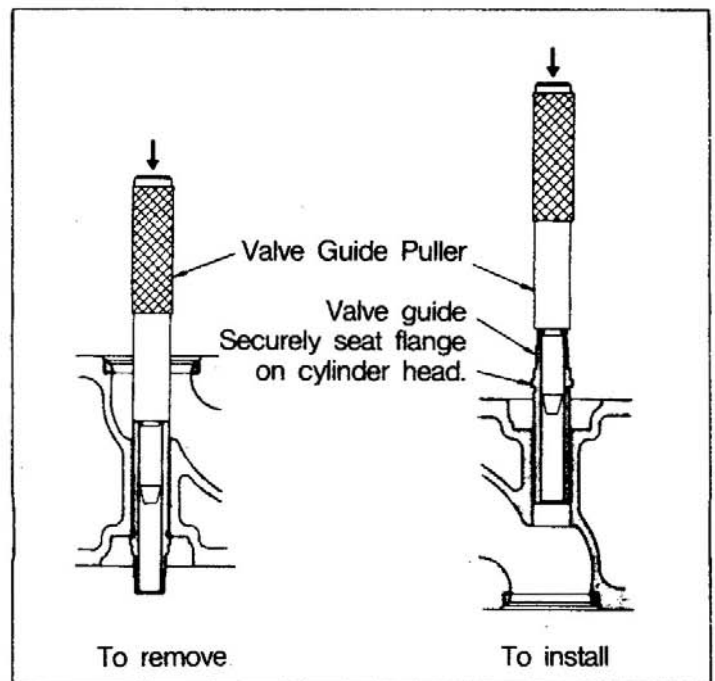

- (5) Check the contacting condition of the valve seat insert and valve. If anything wrong is noted, correct or replace the valve seat insert and valve.

NOTE : 1. The contacting condition should be checked after inspection/replacement of the valve guide.

2. When the valve is pressed against a red lead coated valve seat insert, make sure that the valve is not turned.

(6) Correction of Valve Face

Grind the valve face with a valve refacer. The grinding should be limited to a minimum.

- NOTE : 1. The valve seat angle is 45° .
2. Secure a valve margin of more than 1.7mm for inlet valves and more than 2.0mm for exhaust valves. If these margins cannot be secured after grinding and correction, replace.

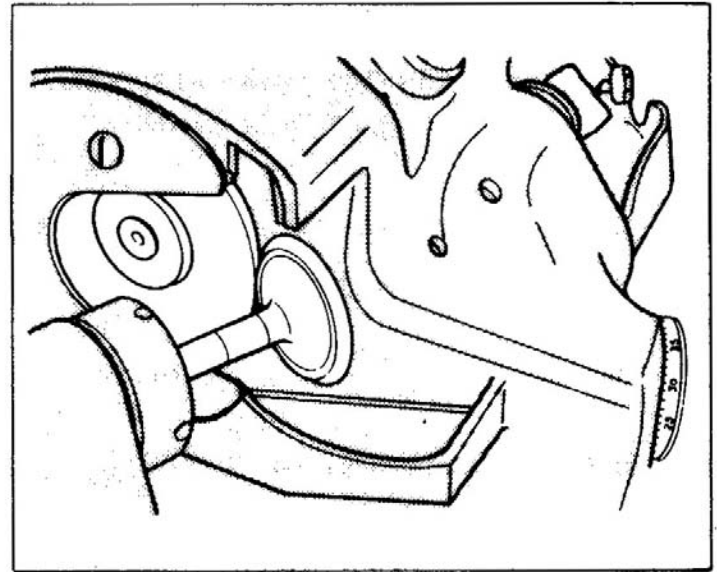
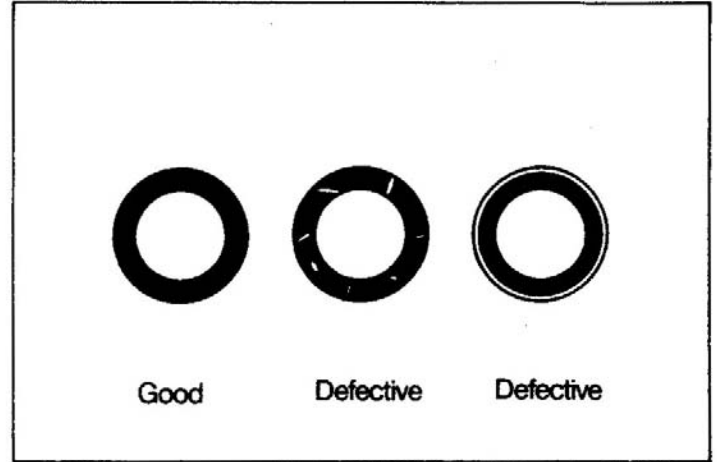

(7) Correction of Valve Seat Insert

- (a) Grind with a valve seat cutter or a valve seat grinder.
- (b) After machining, lightly grind by holding about #400 sandpaper between the cutter and valve seat.

NOTE : 1. The valve seat angle is 45° .

2. If the valve sinkage is beyond the service limit, replace the valve seat insert.

- (c) Correct the seat width to the nominal dimension, using a 15° cutter.
- (d) Seat the valve and valve seat insert. Refer to Para.(9).

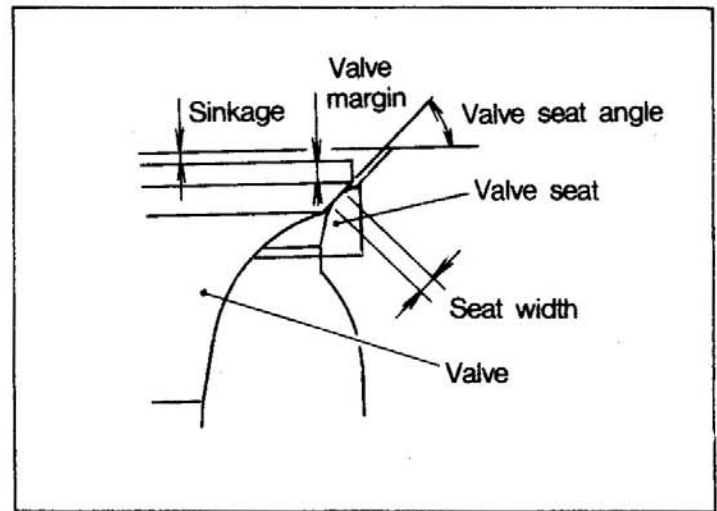
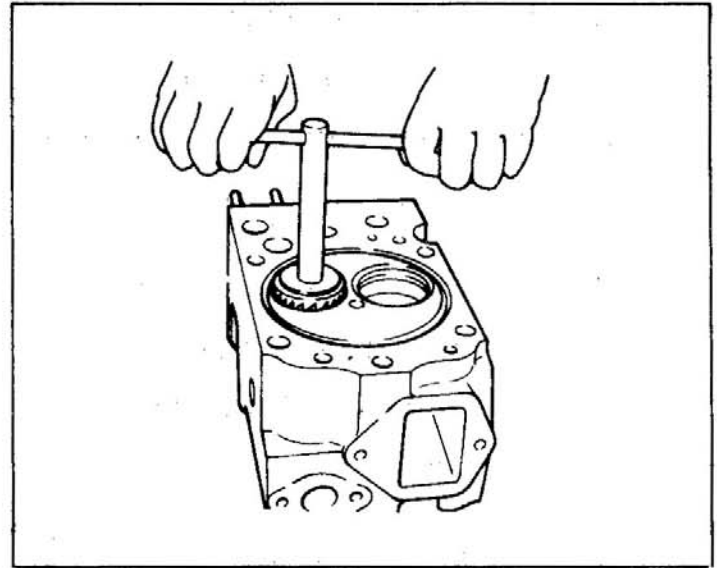

(8) Replacement of Valve Seat Insert

Since the valve seat insert is cold fitted, replace it by the following procedures.

- (a) Grind the valve seat insert from inside to reduce the thickness, and remove it at normal temperature.
- (b) Check to ensure that there is enough interference between the cylinder head and valve seat insert.
- (c) Cool the valve seat insert by immersing in liquid nitrogen. The cylinder head should be fully heated.

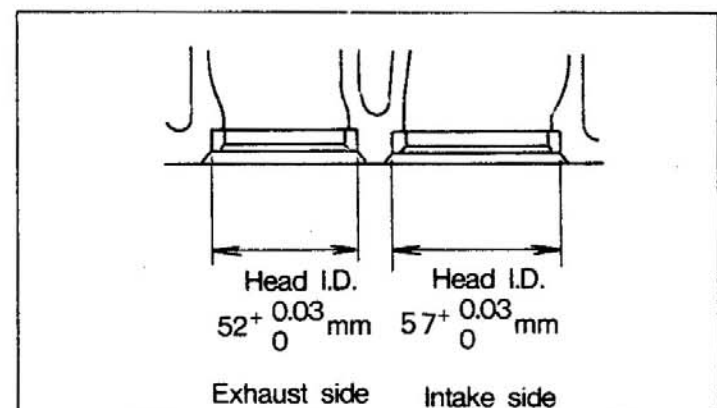
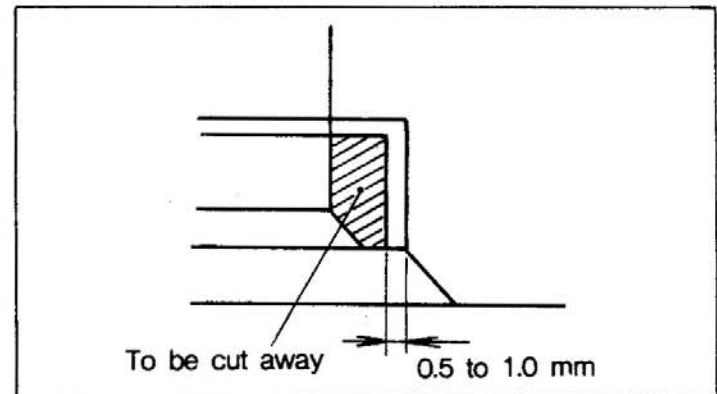

- (d) Using Caulking Tool (special tool), install the valve seat insert and caulk the periphery of the valve seat.

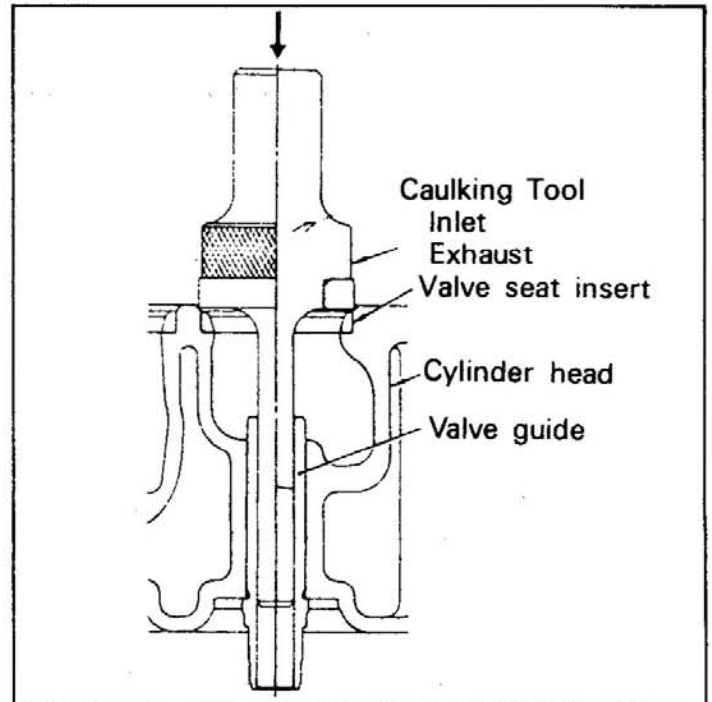

- (e) Reface the valve seat insert so that the seat width and valve sinkage will have the nominal dimensions.

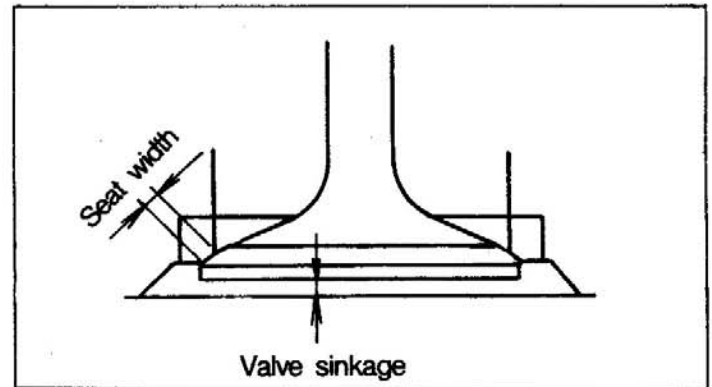

(9) Seating of Valve and Valve Seat Insert

The valve and valve seat insert must be in even contact throughout.

When the valve or valve seat insert is corrected or replaced, make sure that they are seated.

- (a) Apply a thin coat of compound evenly to the seating surface of the valve.

NOTE : 1. Make sure that there is no compound on the stem of the valve.

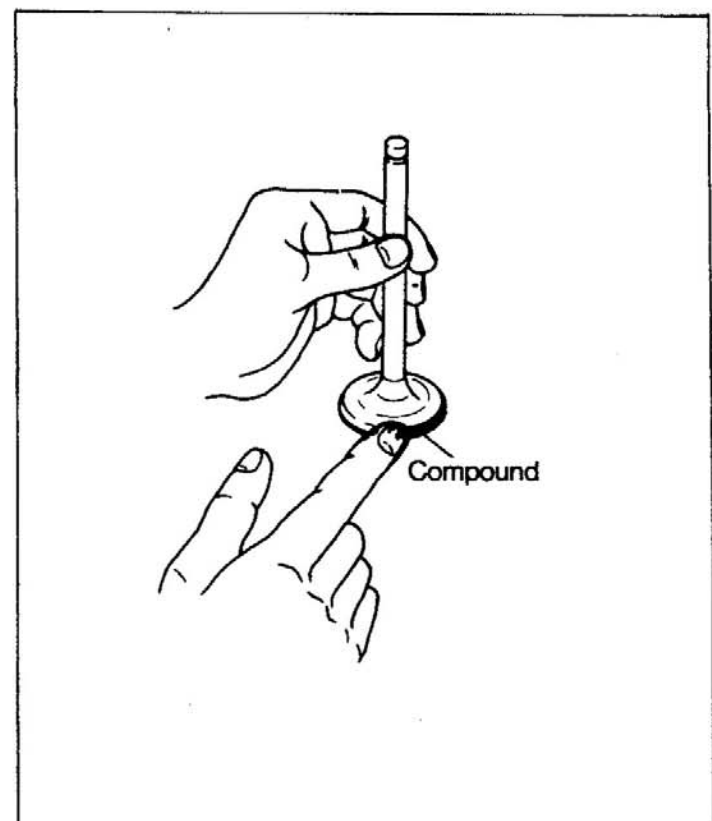

2. Use intermediate mesh compound(120 to 150 meshes) first and then use fine mesh compound (200 meshes or more) for finishing.
3. If the compound is mixed with a small amount of engine oil, it can be evenly applied.

- (b) Using Valve Lapper(special tool), seat the valve and valve seat insert.

While turning the valve slightly at a time, strike it against the valve seat insert.

- (c) Wash away the compound in gas oil, etc.
- (d) Apply engine oil to the contacting surface to seat them with oil.
- (e) Check to ensure that they are properly seated.

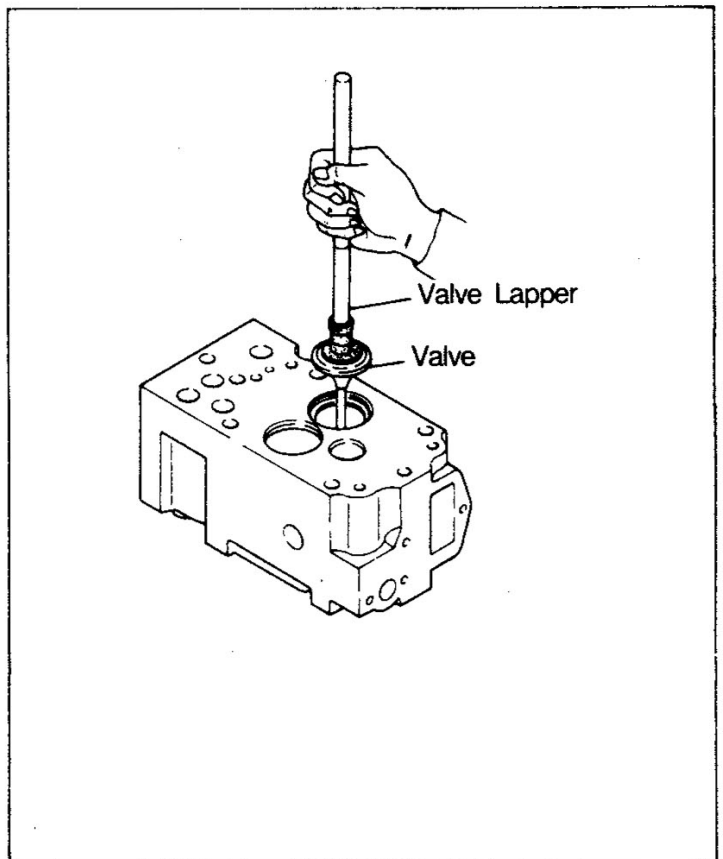

7-2-3 Flywheel

Check the ring gear. If broken teeth or abnormally worn tooth surface are evident, replace by the following procedures.

(1) Replacement of Ring Gear

(a) Removal

- 1) Evenly heat the ring gear with an acetylene torch, etc.
- 2) While holding a protective rod, strike the ring gear all around with a hammer to force it out of position.

(b) Installation

- 1) Heat the ring gear with piston heater (approx. 100°C) for three minutes.
- 2) Fit the ring gear onto the flywheel with the nonchamfered side of tooth end toward the flywheel.

(2) Friction Surface distortion

Place the flywheel on a surface plate and move a dial indicator in the diametral direction of the flywheel to measure distortion.

Use of a portable jack will make it possible to take a more accurate reading.

If the distortion is in excess of the repair limit, grind the friction surface.

NOTE : If the ring gear shows an abnormal condition, replace the ring gear before measurement.

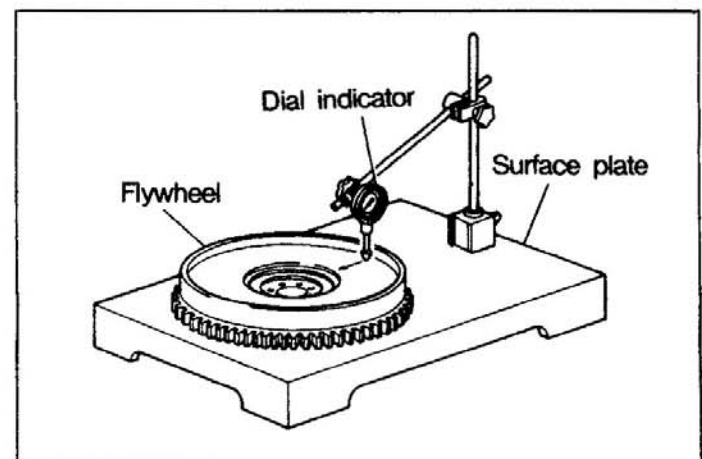
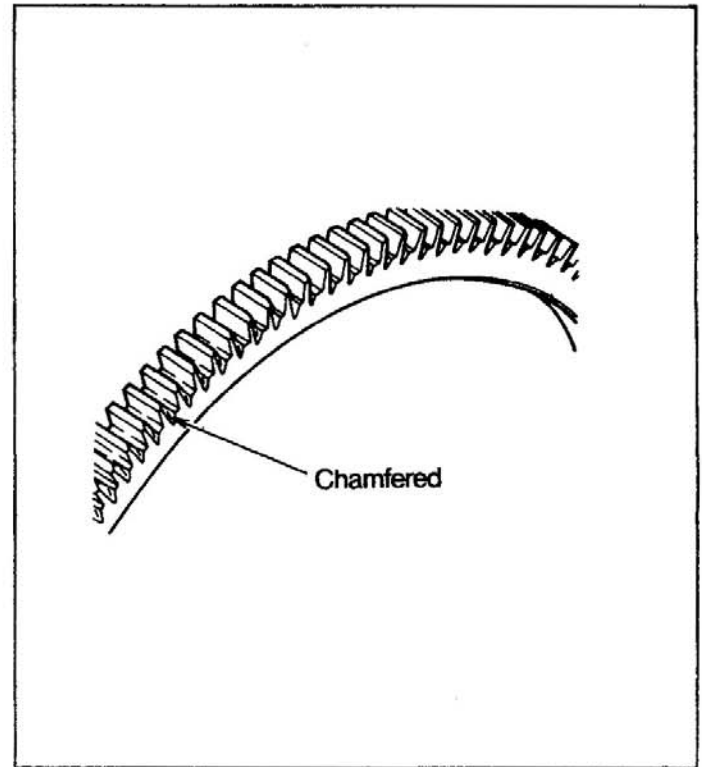

- (3) If the distortion of the surface making friction with the clutch is in excess of the repair limit, grind.

Make sure that the friction surface is parallel to surface A with in 0.1mm.

If the dimension of portion B exceeds the service limit, replace.

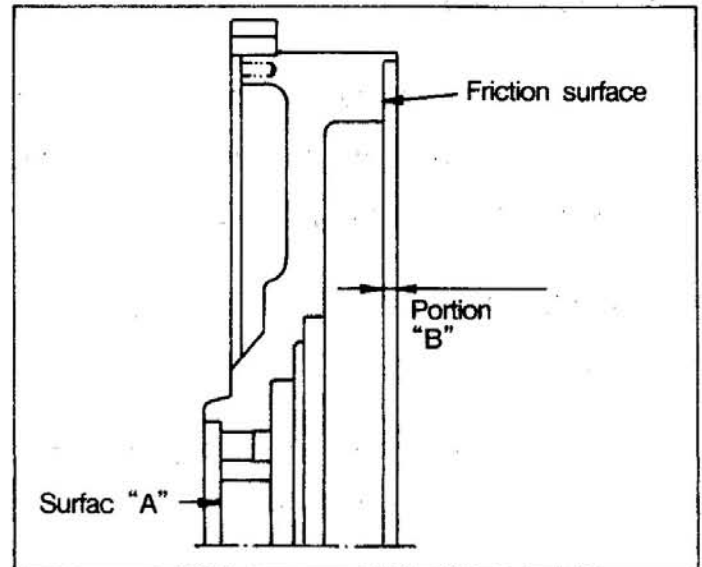

7-2-4 Timing Gear

- (1) Calculate the clearance from the idler gear I.D. and idler shaft O.D. If the repair limit is exceeded, the bushing in the gear should be replaced.

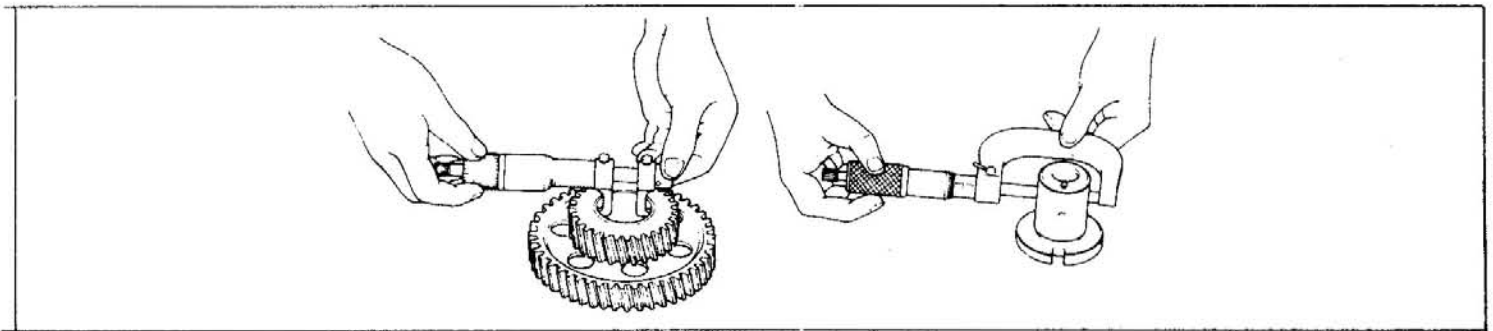

(2) Replacement of Idler Gear Bushing

Replace the bushing by the procedures shown in illustration, using Idler Gear Bushing Puller(special tool).

NOTE : 1. Install the bushing with chamfered side of gear I.D. inward.

2. After installation, check to ensure that the bushing to idler shaft clearance is within the nominal dimension. If it is below the nominal dimension, ream the bushing.

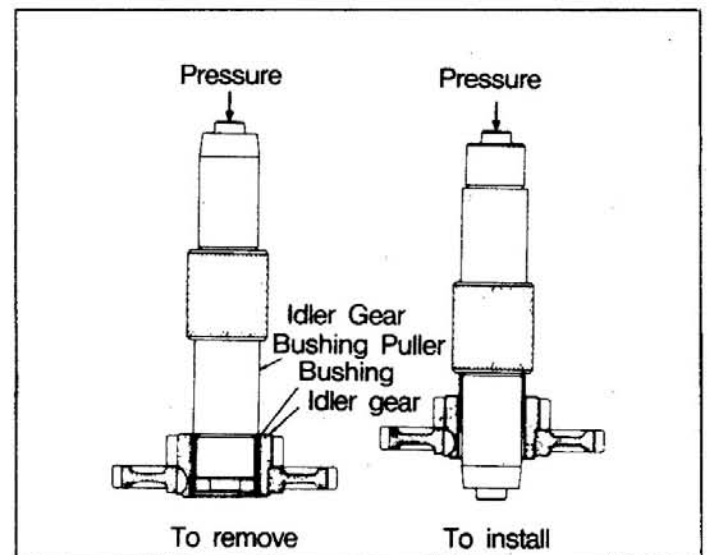

7-2-5 Camshaft

- (1) Measure the lobe height and base circle diameter of each cam. If the difference between them is below the service limit, replace.

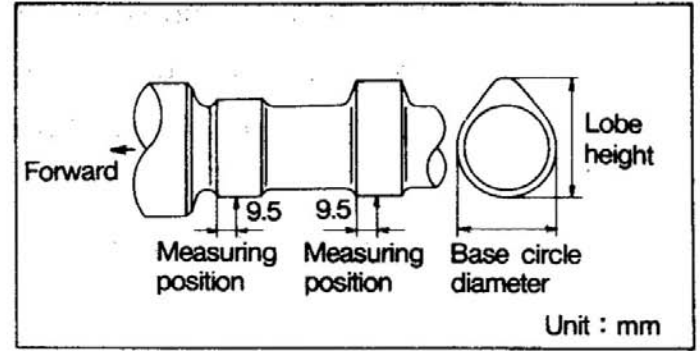

- (2) Measure the camshaft journal O.D. and crankcase I.D. If the repair limits are exceeded, the bushing in the crankcase should be replaced.

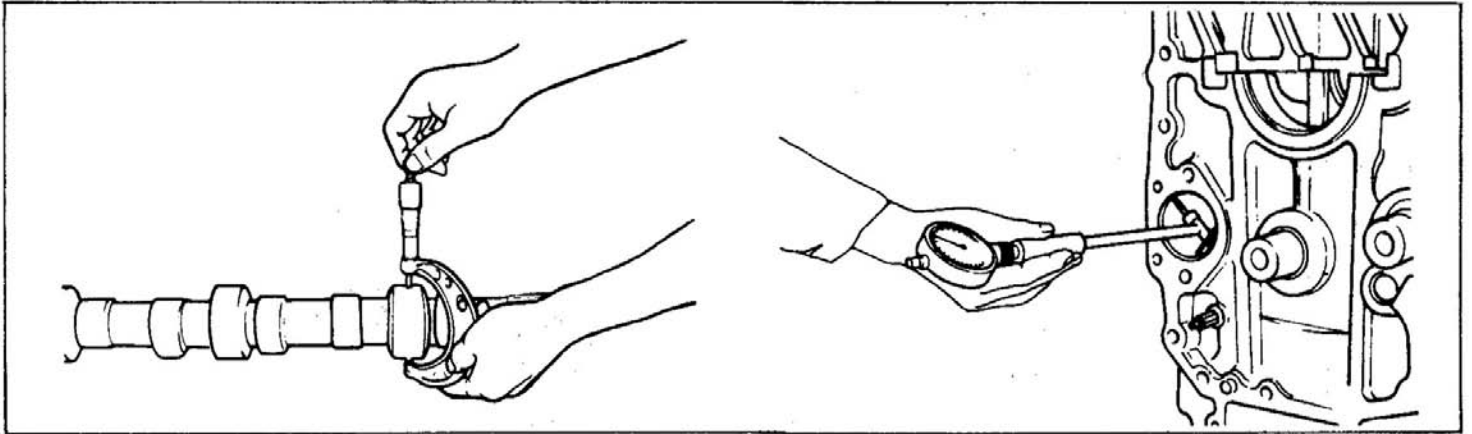

(3) Replacement of Camshaft Bushing

Remove the camshaft bushing screws to remove the bushing. Since the bushing and crankcase are clearance fitted, they are easily replaceable.

NOTE : For installation, pay attention to the following points.

1. Thread the set screw positively into the set hole of the bushing.

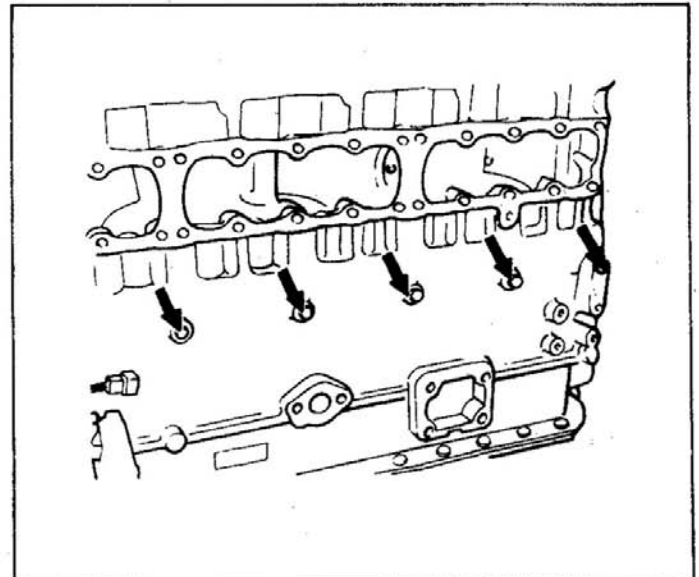

2. The number stamped on the external periphery of bushing near the set screw hole shows the position where the bushing is to be installed. Insert the bushings in the order of 3-4-5-5-6-6-7 from the front. At that time, the set screw hole(Ø8mm) and threaded hole of the crankcase should be aligned.

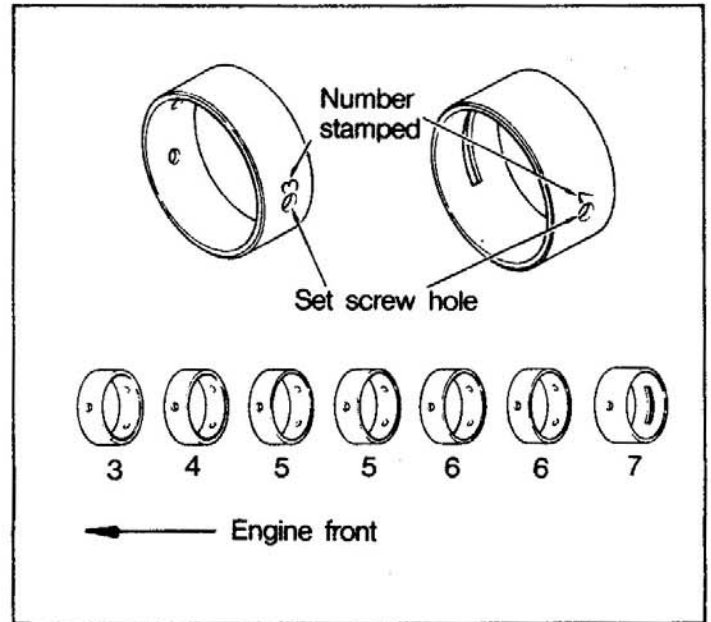

(4) Measure the bend of the camshaft. If the repair limit is exceeded, correct with a press or replace.

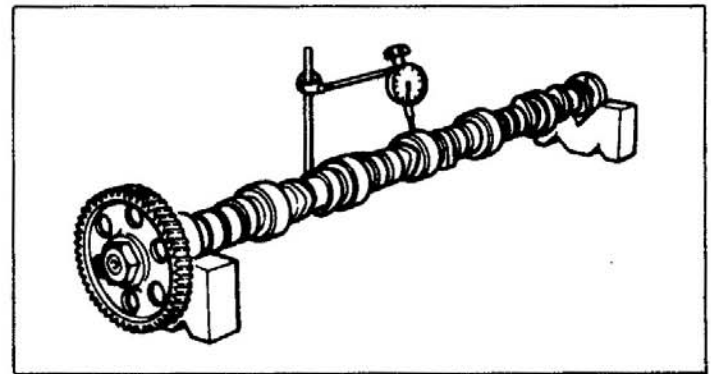

NOTE : Turn the camshaft a turn and read the deflection of the pointer, using a dial indicator.
One half of the reading is the bend.

7-2-6 Crankcase and Cylinder Liner

(1) Measure the cylinder liner I.D. at six positions shown in illustration. If the I.D. is in excess of the repair limit, replace or bore to oversize.

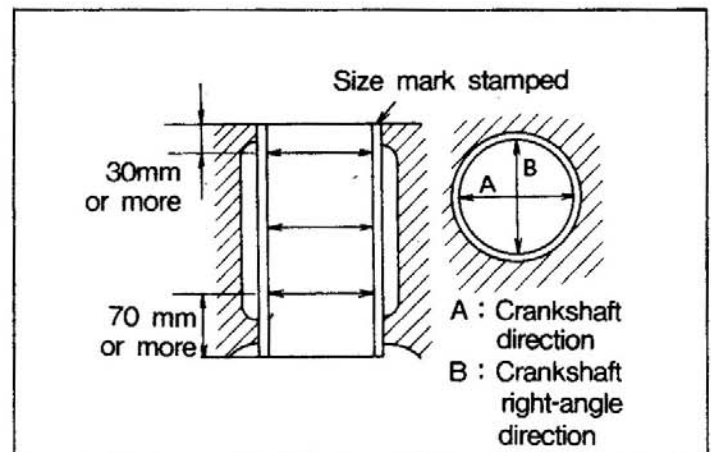

If the out-of-roundness and cylindricity are in excess of the repair limit, take the same corrective action.

NOTE : When a cylinder liner needs replacing, make sure that the liner with the same size mark as that of the piston is selected.

Piston size mark	A	B	C
Cylinder liner size mark	A	B	C

- (2) Measure the cylinder liner flange to determine whether it is projecting from the top surface of the crankcase as specified.

If the projection is out of specification, replace the cylinder liner or crankcase.

NOTE : If the projection is in sufficient, the surface pressure around the bore of the cylinder head gasket will fall and cause gas leakage.

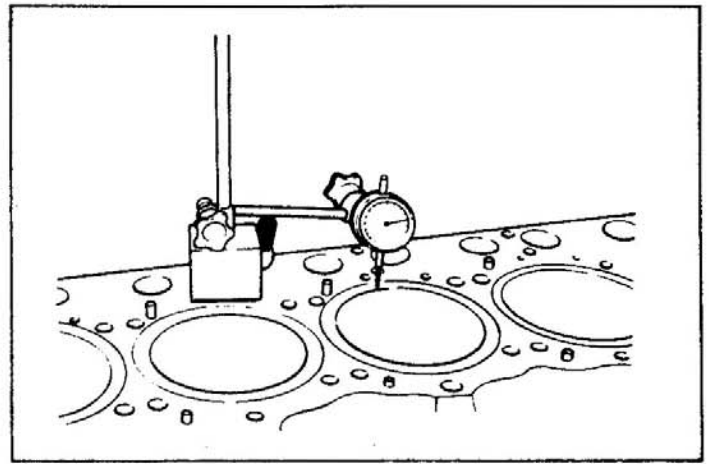

(3) Replacement of Cylinder Liner

- (a) Remove the cylinder liner through use of cylinder Liner Extractor(special tool).

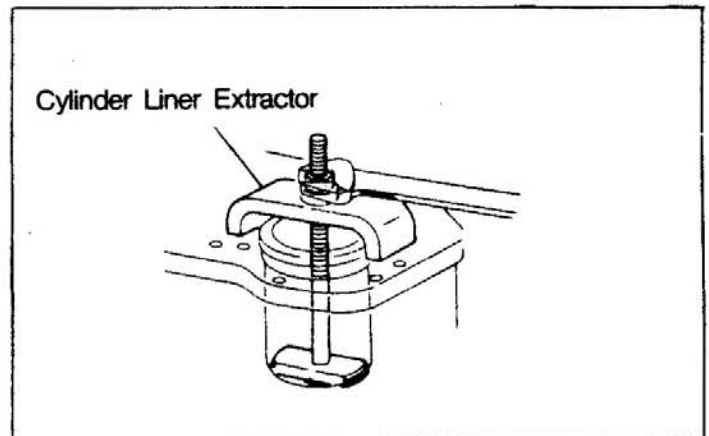

- (b) After the rubber packing and O-ring have been installed to the cylinder liner, slowly insert the cylinder liner into the crankcase.

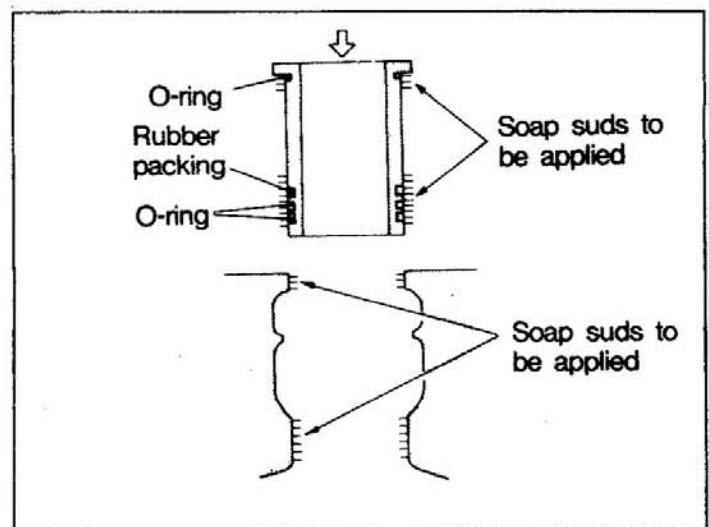

NOTE : Apply soap suds to the crankcase and cylinder liner fitting portions and make sure that the rubber packing and O-ring are not twisted when inserted.

(c) Securely seat the cylinder liner on the crankcase by lightly striking the flange portion, using Cylinder Liner Installer(special tool).

NOTE : After installation, make leak test to confirm air-tightness. Keep hold-down pressure on the cylinder liner flange portion.

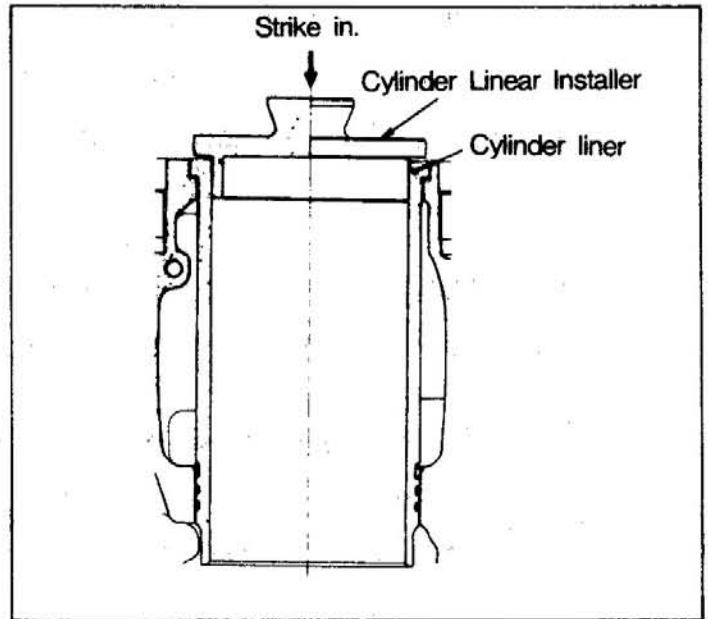

(4) Measure the crankcase top surface distortion. If the repair limit is exceeded, correct the distortion with a surface grinder. If the service limit is exceeded, replace the crankcase.

NOTE : When the crankcase is ground, make sure that the piston projection does not exceed the nominal dimension.

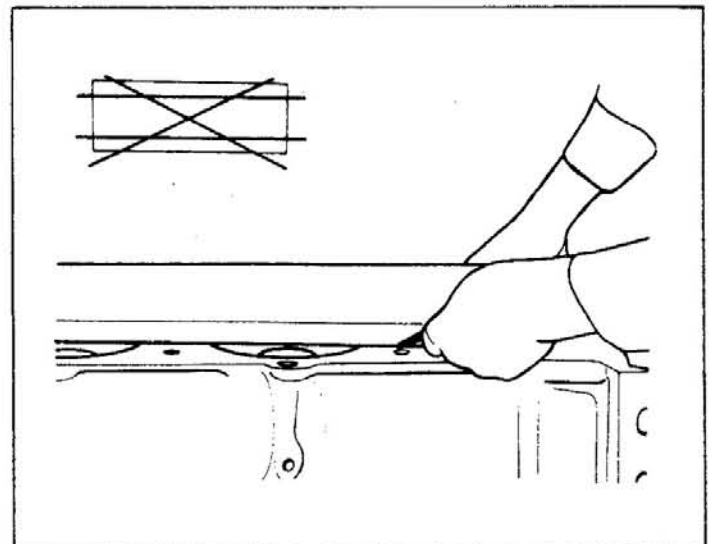

(5) Oversize of Cylinder Liner

Oversize(three kinds)

+0.5mm, +0.75mm and +1.00mm

(a) Selection of an oversize should be accomplished in consideration of the maximum worn portion from all cylinder I.D. measurements.

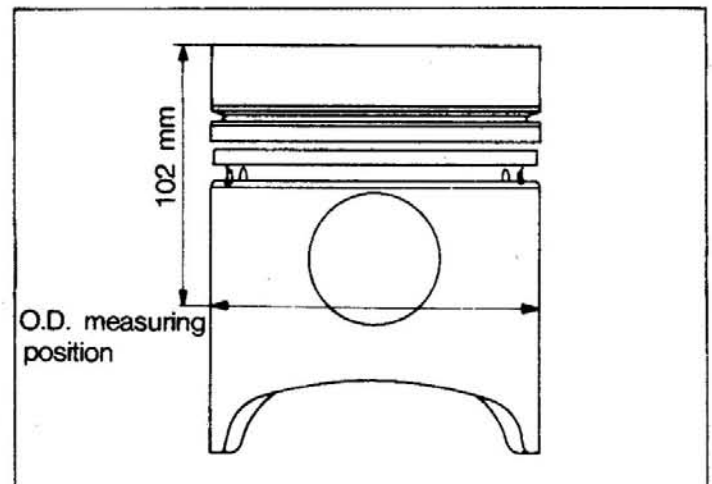

- (b) Measure the O.D. of each oversize piston to be used, using a micrometer.
- (c) Bore and hone-finish the cylinder liner so that the cylinder liner to piston clearance will have the nominal dimension.

NOTE : 1. Even if it is only one cylinder that needs boring, make sure that all cylinders are bored to the same oversize.

2. The piston rings should be replaced with corresponding oversize rings.

7-2-7 Piston and Piston Ring

(1) Replacement of Piston

- (a) If the piston to be replaced is a standard(STD) one, select one of the same size mark as stamped on the cylinder liner.
- (b) The weight of six pistons for a vehicle must fall within the range of 10 g difference in stamped value of weight.
- (c) Make sure that the piston rings are also replaced.

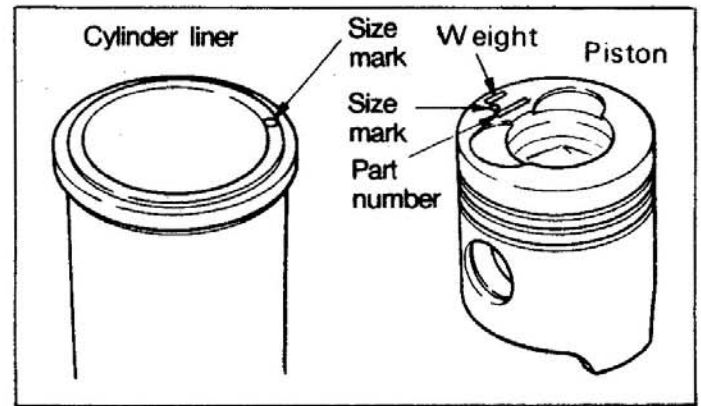

- (2) Measure the piston skirt O.D. and calculate the clearance from the measured value of cylinder liner I.D., refer to Para. 7-2-6(1). If the nominal dimension is exceeded by a large margin, replace the cylinder liner or piston.

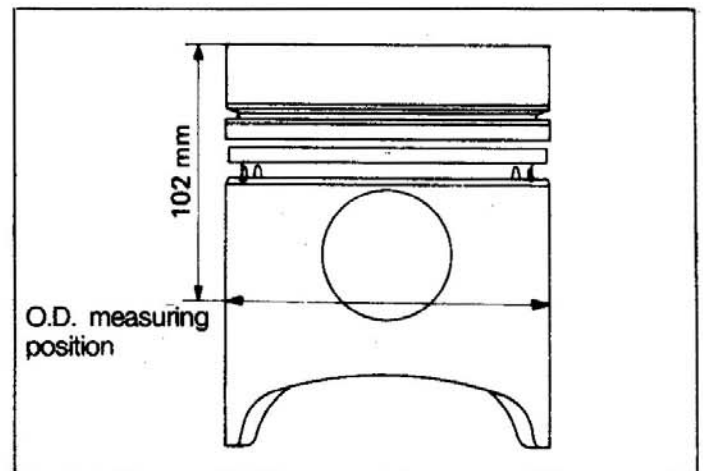

- (3) Measure the piston to piston ring clearance. If the service limit is exceeded, replace the piston rings or piston.

NOTE : 1. After carbon has been removed, measure the clearance all around the piston.

2. Replace the piston rings as a set.

The 1st compression ring should be measured by pressing the ring against the piston with a straight edge.

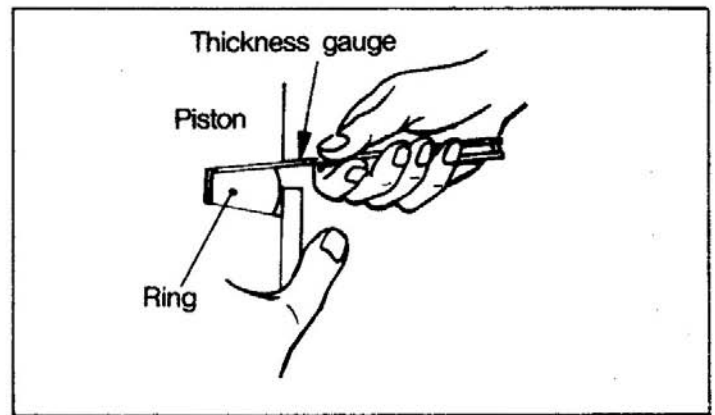
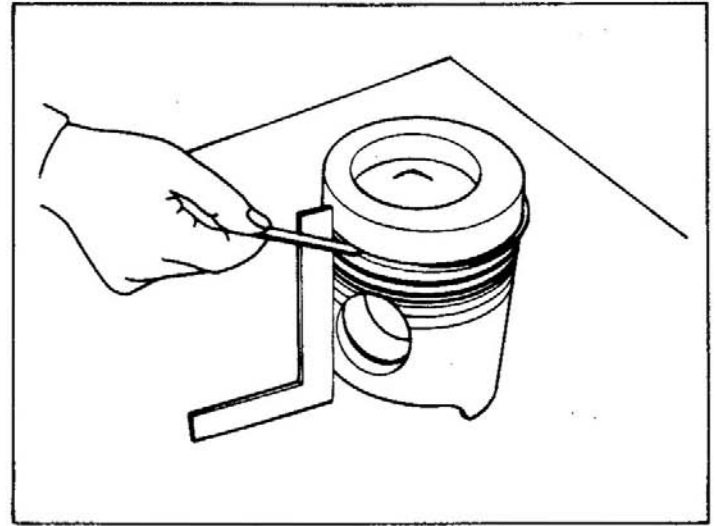

- (4) Place the piston ring in a standard gauge or new cylinder to measure the open end clearance.

If the clearance is over the service limit, replace.

Standard gauge I.D. $130 \pm 0\text{mm}$

NOTE : Using a piston, push the piston ring in horizontally into a standard gauge cylinder.

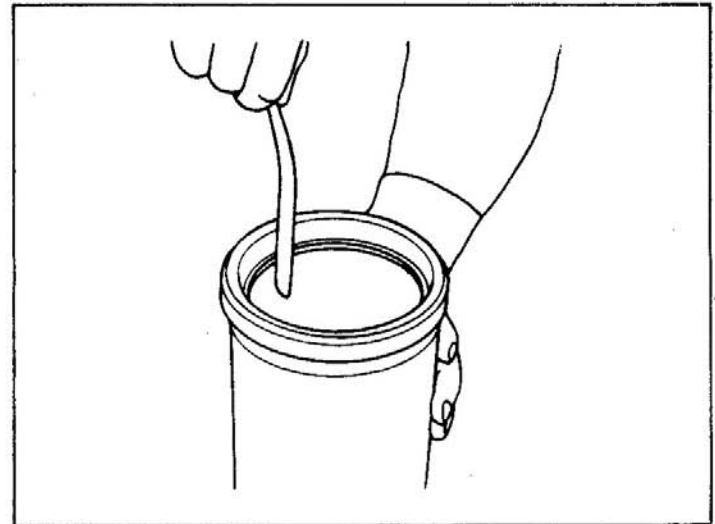

- (5) Calculate the clearance from the piston pin O.D. and piston I.D.

If the clearance is over the service limit, replace the piston pin or piston.

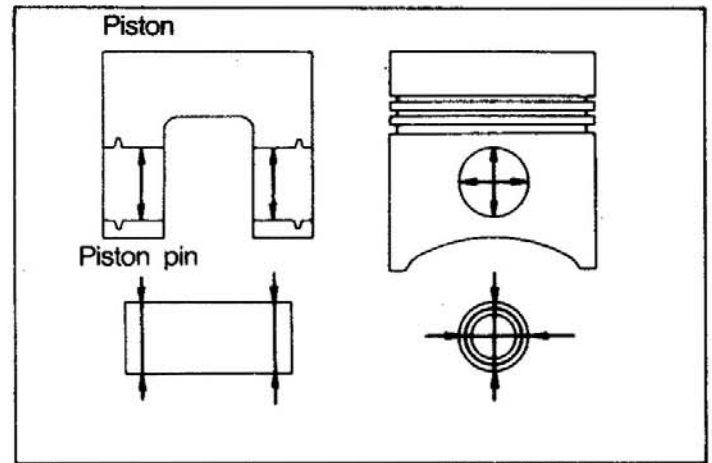

7-2-8 Connecting Rod

- (1) Calculate the clearance from the piston pin O.D. and connecting rod I.D.

If the clearance is over the repair limit, replace the bushing in the connecting rod.

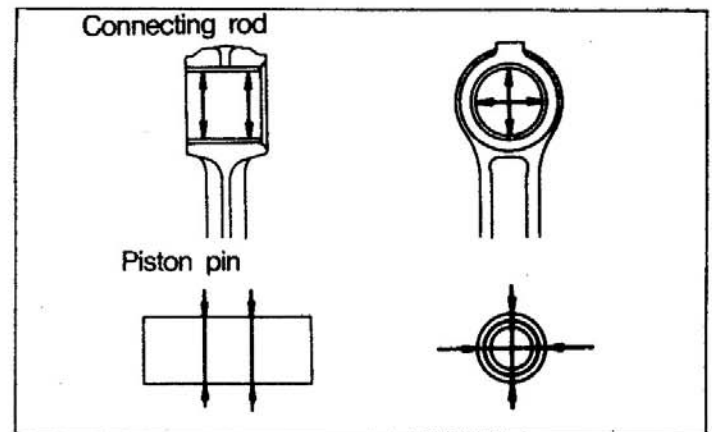

- (2) Replacement of Connecting Rod Bushing

Replace the bushing by procedures shown in illustration, using Connecting Rod Bushing Puller (special tool).

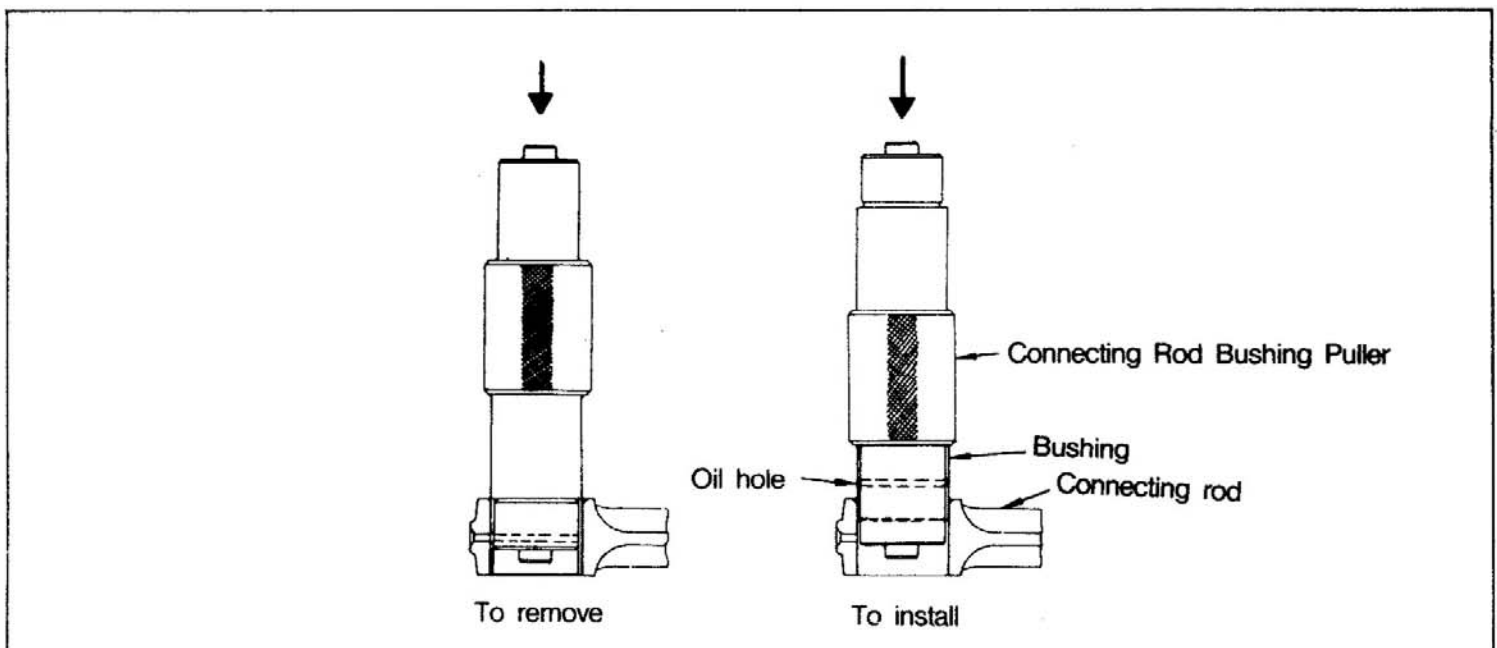

(a) Align the oil hole of the bushing with the oil hole of the connecting rod.

(b) Press the bushing in from the chamfered side of connecting rod end.

(c) After the bushing has been pressed in, insert the piston pin and check to ensure that it turns lightly without play.

(3) Measure the bend and torsion of the connecting rod with Connecting Rod Aligner (measuring instrument).

If the reading is in excess of the repair limit, replace or correct with a press.

NOTE : 1. Install the bushing and connecting rod bearing to the connecting rod before measurement.

2. Tighten the connecting rod and connecting rod cap to the specified torque before measurement.

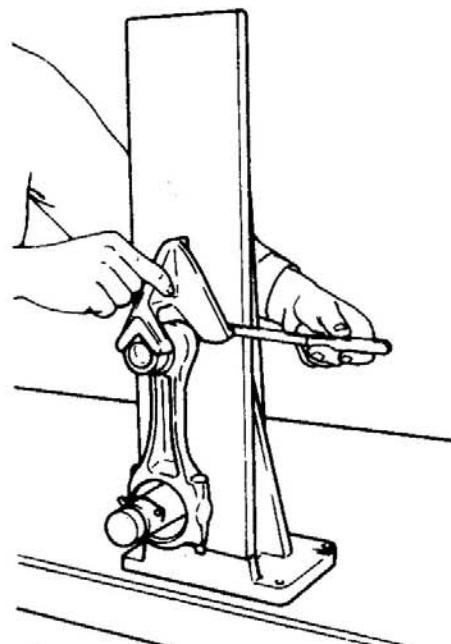
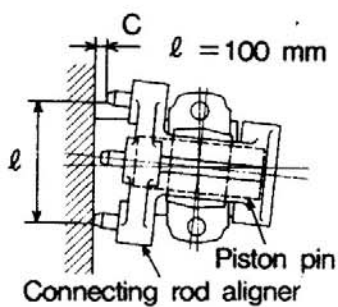
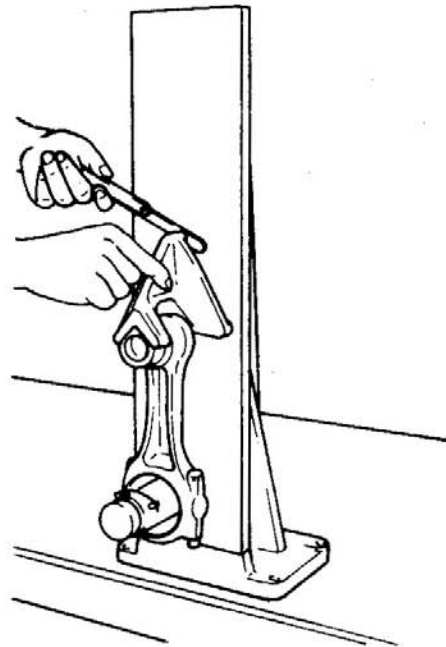
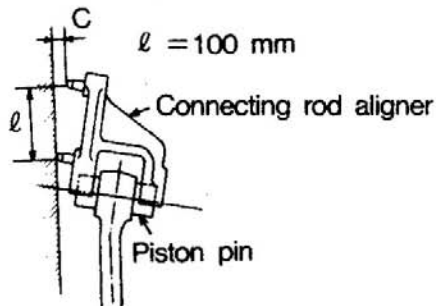

- (4) Measure the free time tension of the connecting rod bearing. If the tension is lower than the service limit, replace the upper and lower bearings as a set.

NOTE : Do not use the bearing by artificially expanding it.

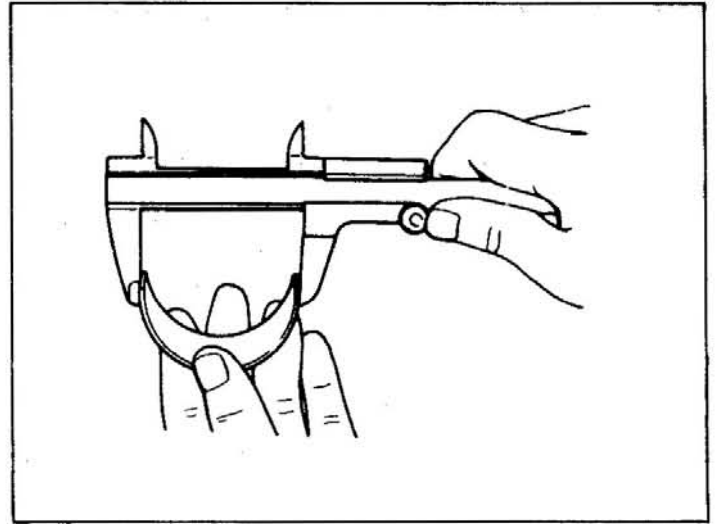

- (5) Calculate the clearance from the bearing I.D. and crankshaft O.D. If the repair limit is exceeded, replace the upper and lower bearings as a set.

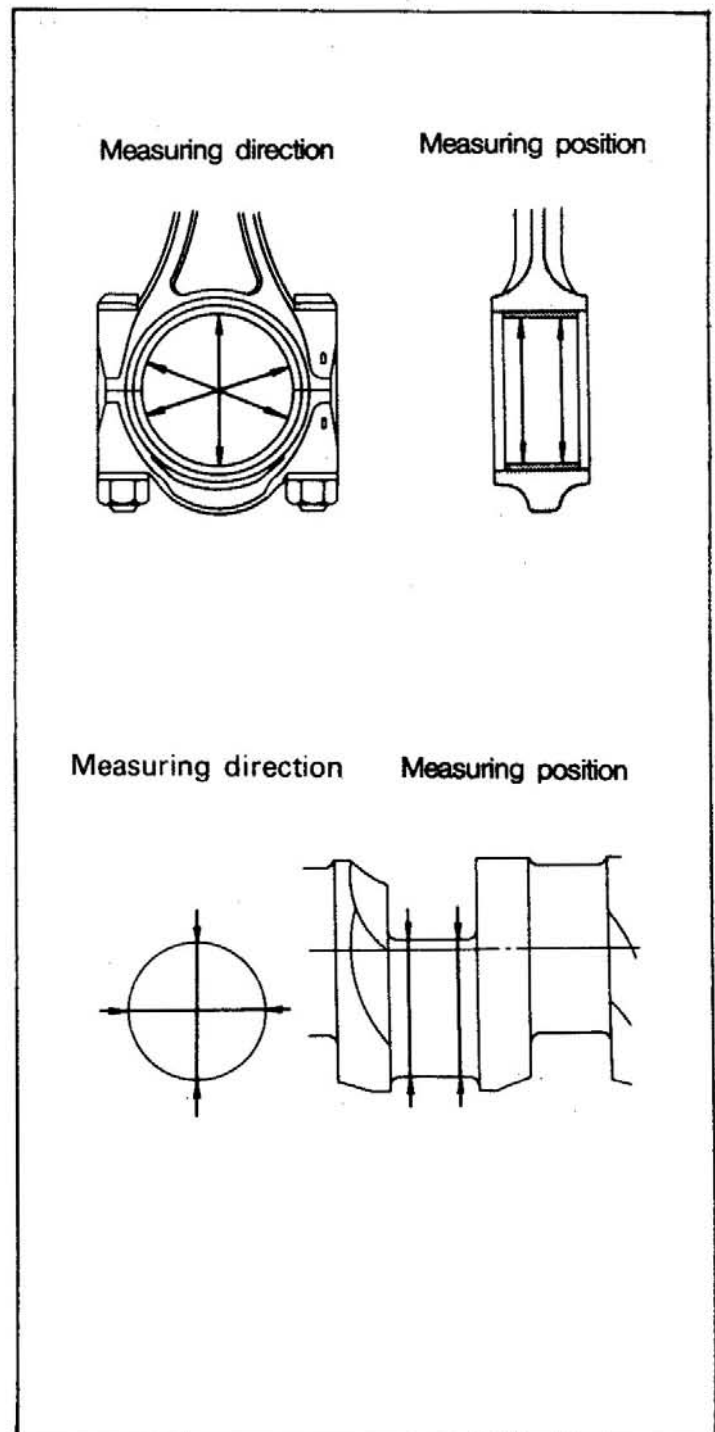

7-2-9 Crankshaft and Main Bearing

- (1) Calculate the clearance from the main bearing I.D. and crankshaft O.D. If the repair limit is exceeded, replace the upper and lower bearings as a set.

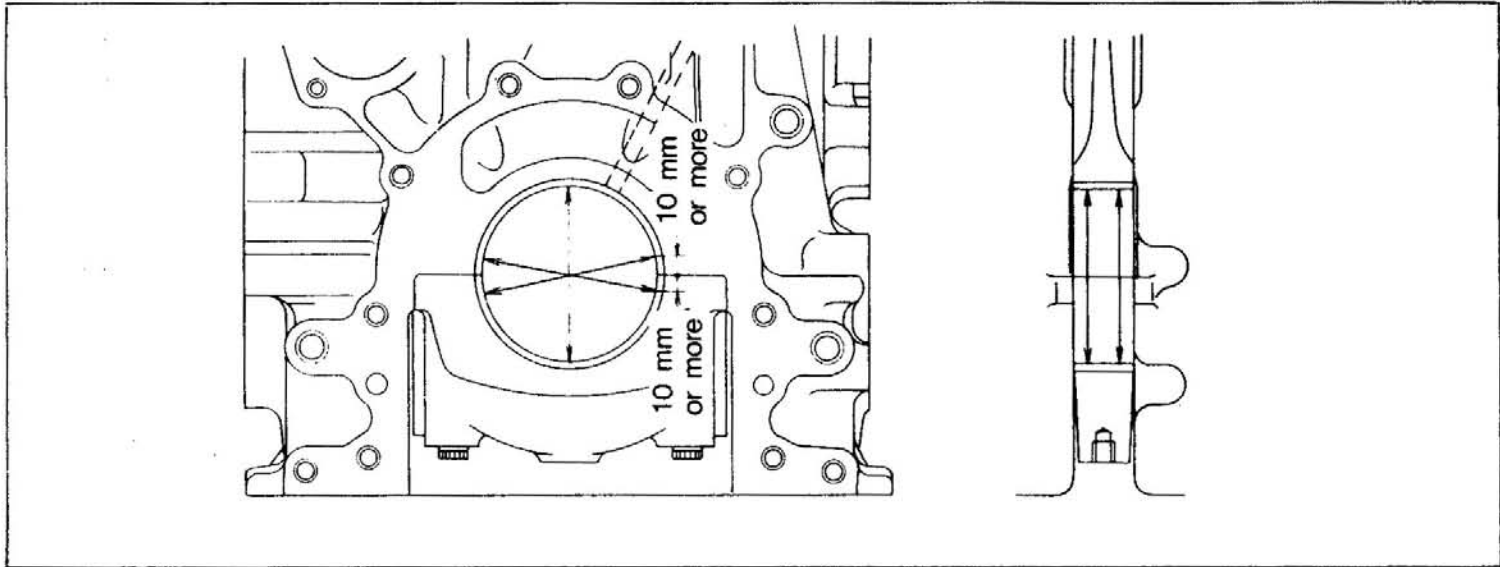
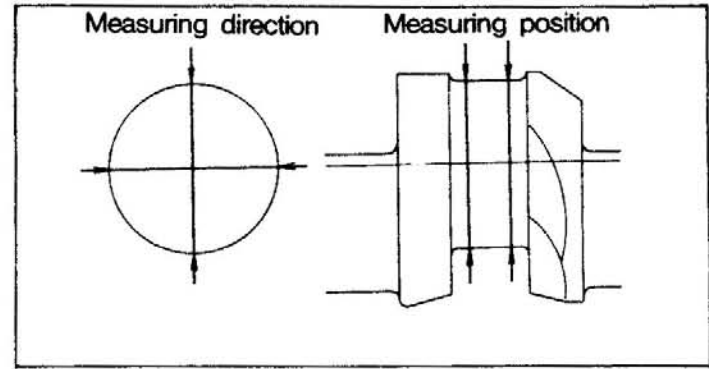

- (2) Measure the free time tension of the main bearing. If the tension is below the service limit, replace the upper and lower bearings as a set.

NOTE : Do not use the bearing by artificially widening it.

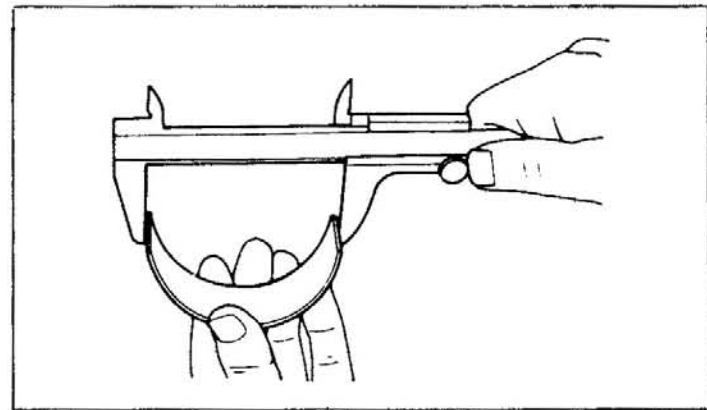

- (3) Determine the out-of-roundness on the basis of the crankshaft journal and pin O.D. measurements.

If the repair limit is exceeded, grind to undersize.

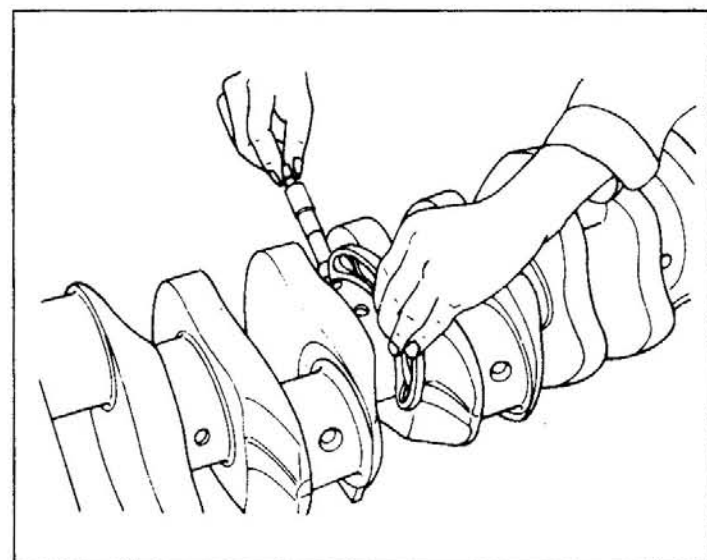

- (4) Measure the bend of the crankshaft. If the repair limit is exceeded, correct with a press or grind to undersize.

NOTE : Read the crankshaft center journal runout with a dial indicator. One half of the reading is the bend.

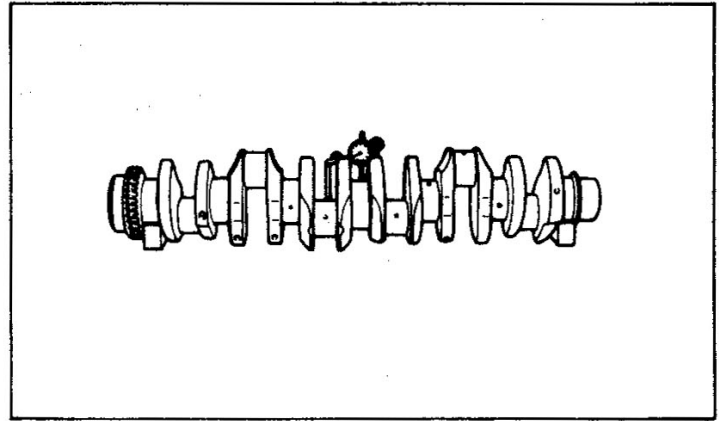

(5) Correction of Crankshaft to Undersize

If the journal or pin is damaged or seized, grind the crankshaft by the following procedures. Replace the bearing with an undersized one.

- (a) When the crankshaft is ground, take care not to change the center distance of journal and pin.
- (b) Grind the crankshaft in such a way as not to change the width of journal and pin.
- (c) Finish the fillet smooth to the specified R.
- (d) Check for ground cracks by the magnetic particle inspection method. The surface hardness(Hs 75 or more) should also be checked to confirm that it has not decreased.
- (e) To grind the crankshaft with grinder, the grinder and crankshaft should be turned clockwise as viewed from the crankshaft front end.

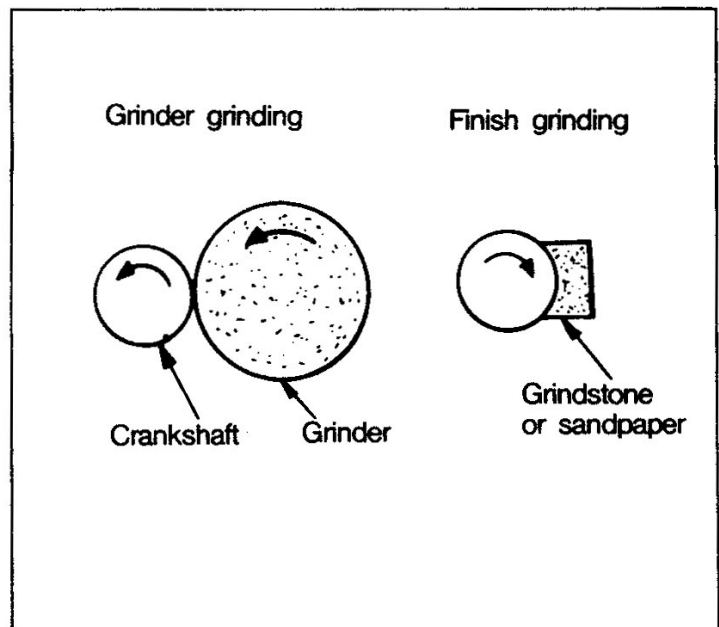
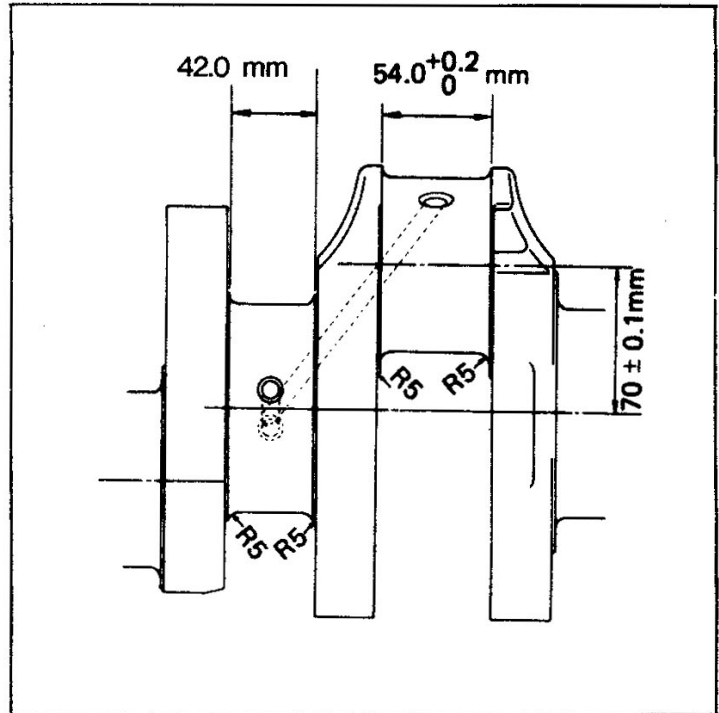

- (f) To finish the crankshaft with a grindstone or sandpaper, turn the crankshaft counterclockwise.

Undersize	Journal O.D. finish dimension		Pin O.D. finish dimension		Out-of-roundness	Cylindricity
-0.25	99.75	-0.08 -0.10	83.75	-0.06 -0.09	0.01 or less	0.006 or less
-0.50	99.50	-0.08 -0.10	83.50	-0.06 -0.09		
-0.75	99.25	-0.08 -0.10	83.25	-0.06 -0.09		
-1.00	99.00	-0.08 -0.10	83.00	-0.06 -0.09		
-1.25	98.75	-0.08 -0.10	82.75	-0.06 -0.09		
-1.50	98.50	-0.08 -0.10	82.50	-0.06 -0.09		

(6) Replacement of Crankshaft Gear

- (a) Remove the oil seal slinger from the crankshaft.
- (b) Remove the gear from the crankshaft, using Gear Puller (special tool).

NOTE : Do not attempt removing the gear by striking.

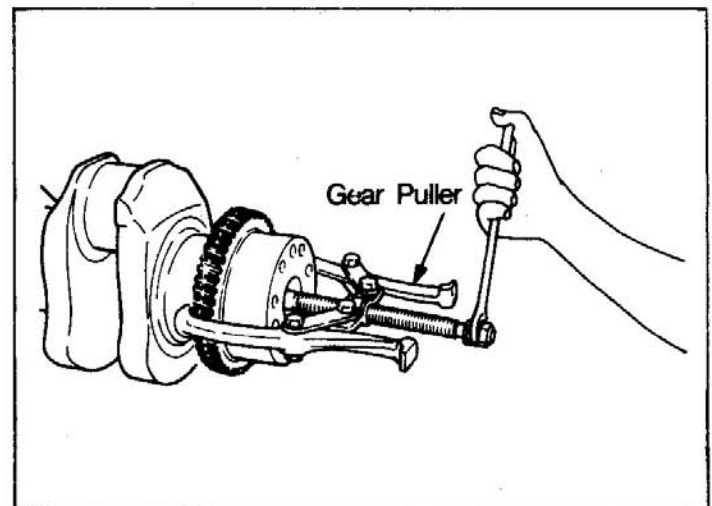

- (c) Heat the gear to about 100°C, using a piston heater, etc.

Locate the gear so that the dowel pin of the crankshaft will fit in the notch of the gear and fit the gear by lightly striking the gear end with a soft hammer.

- (b) Install the oil seal slinger, using Oil Seal Slinger Installer(special tool).

NOTE : Install the oil seal slinger with the threaded surface toward the flywheel.

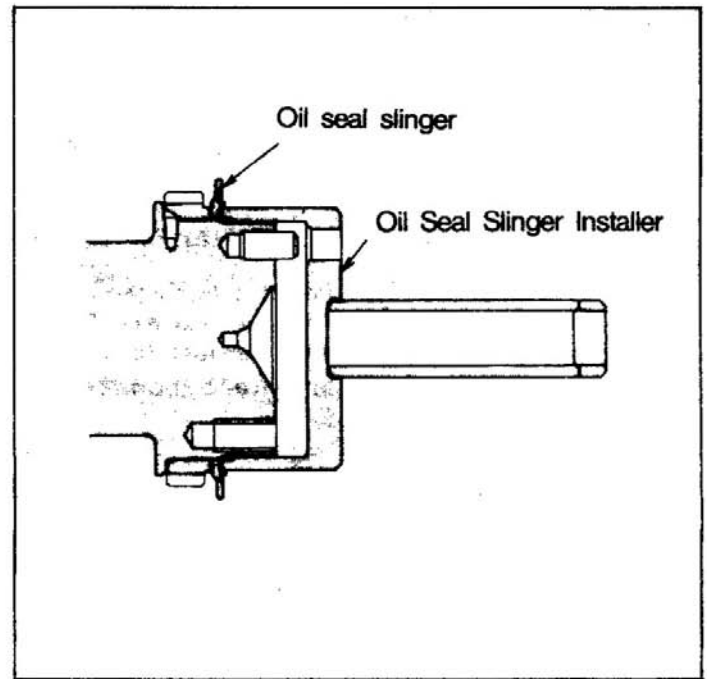

(7) Relacement of Front Slinger

- (a) Remove the front slinger from the crankshaft.

- (b) Install the front slinger, using Front Slinger Installer(special tool).

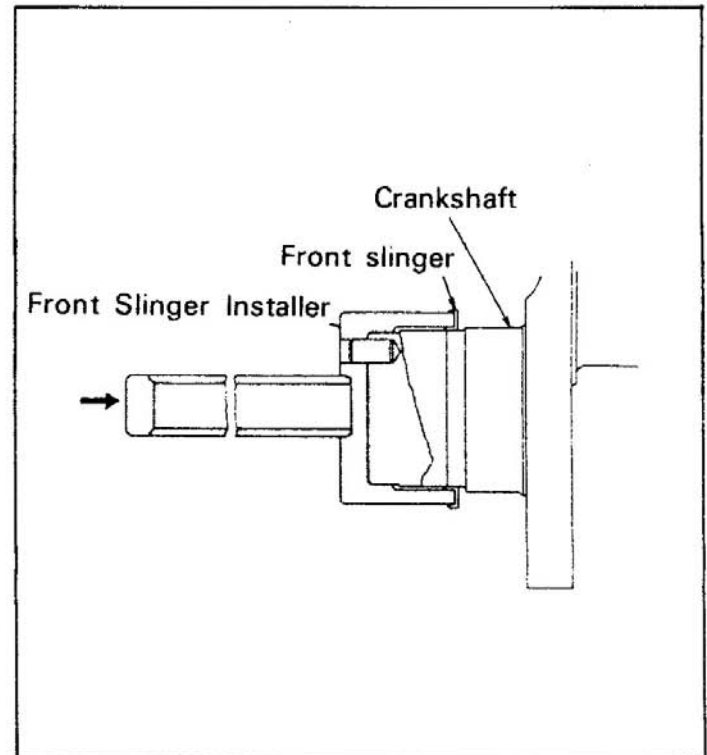

7-3 REASSEMBLY

Observe the following items when proceeding with reassembly.

- (1) Thoroughly clean all parts to be assembled. Check to ensure that there are no dust, oil and water on the joining surfaces of the parts before reassembly.
- (2) The gaskets, O-rings, packings, lock washers, split pins, etc. should be replaced with new ones. Since gasket kits are available, use them at the time of an overhaul.
- (3) Use of sealants is not required as a rule. Where use of a sealant is specified, however, use the specified sealant.
- (4) Parts for which a tightening torque is specified should be tightened to the specified torque. Parts for which no tightening torque is specified should be tightened to the general bolt and nut tightening torque.
- (5) Apply engine oil to all moving parts before reassembly unless otherwise specified.

7-3-1 Crank case and Main Moving parts

NV...Nominal Value
RL...Repair Limit

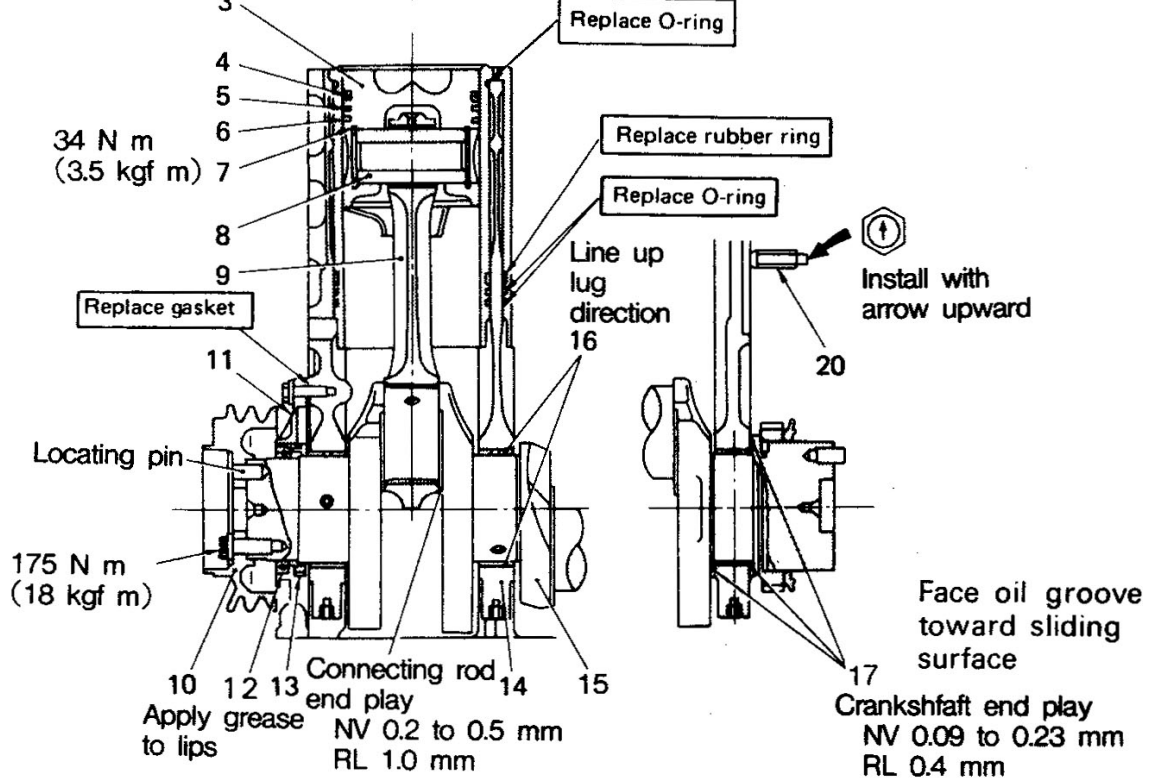
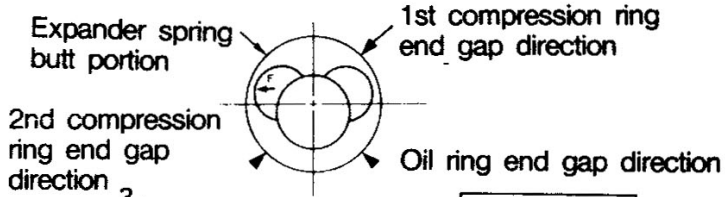
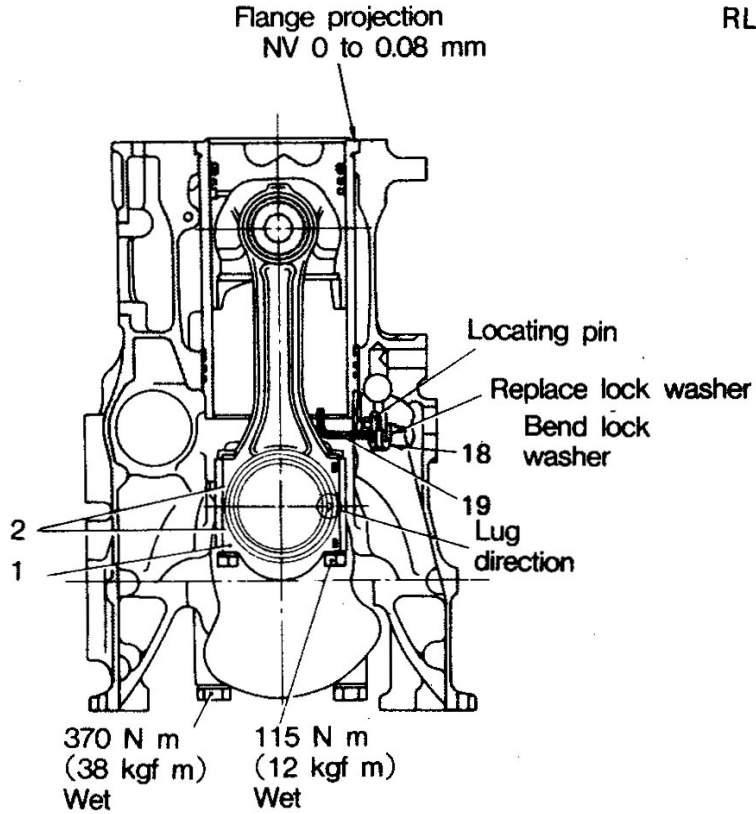

Assembling sequence

20→19→18→17→16→15→14] →2→1→13→12→11→10
3→9→8→7→6→5→4

- (1) Install the oil spray plug 20 to the crankcase.

NOTE : Install the oil spray plug with the arrow stamped on the plug toward the top of the engine.

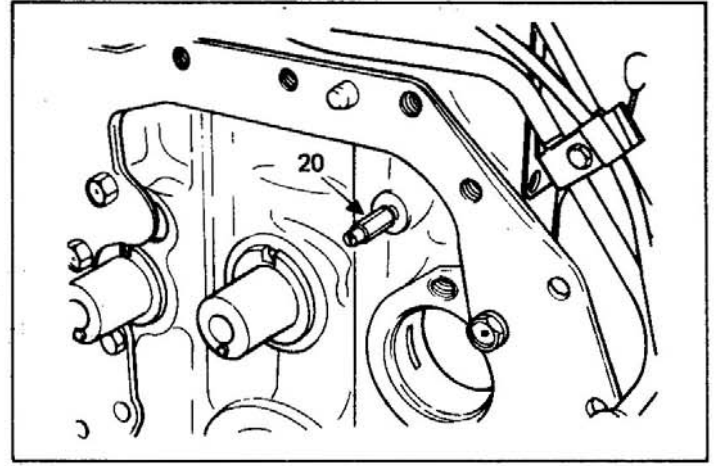

- (2) Tighten the oil jet 19 and check valve 18 to the specified torque. After they have been tightened, bend the lock washer to prevent turning.

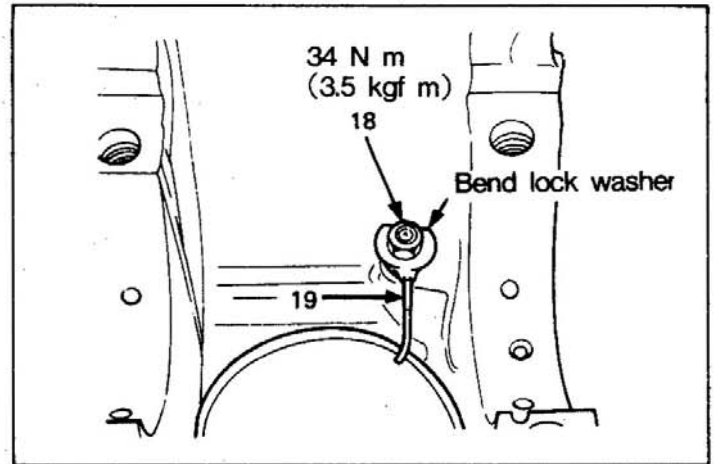

- (3) Install the thrust plate 17 and upper main bearing 16 to the crankcase.

NOTE : 1. Install the thrust plate with the oil grooveless side toward the crankcase.

2. Line up the lug of the main bearing and the groove of the crankcase. The upper main bearing is one with oil holes. Take care not to confuse it with the lower one.

3. The crankcase and rear main bearing cap rear end thrust plates should be the same size.

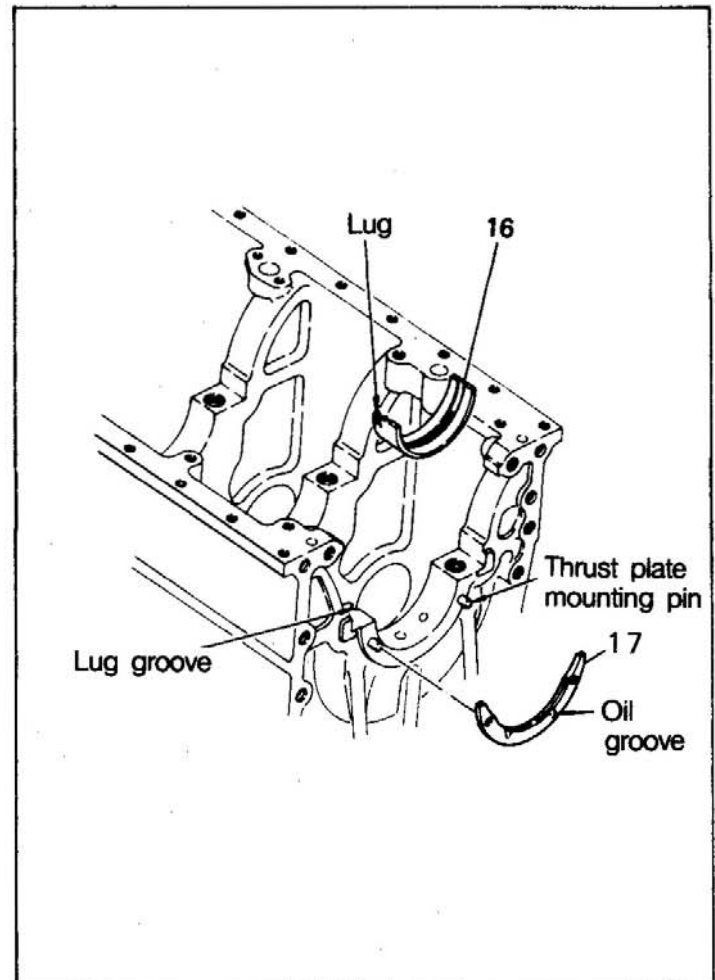

- (4) Lift the crankshaft 15 with chain blocks, etc. While keeping it in horizontal position, slowly lower it into the crankcase.

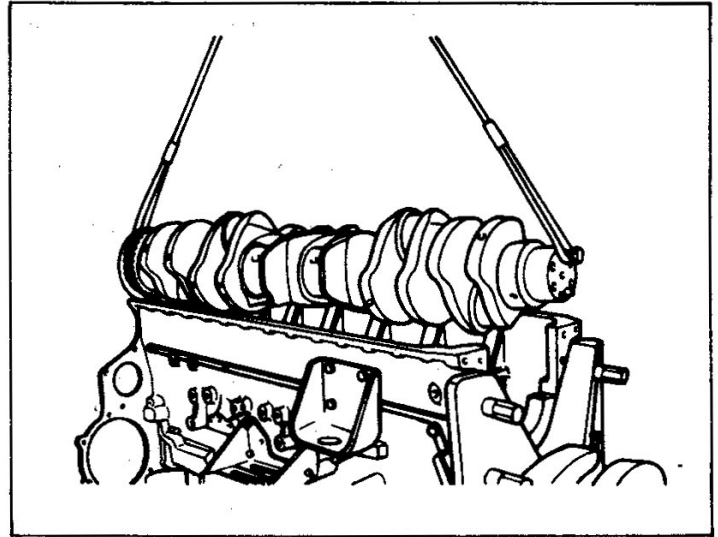

- (5) Fit the lower main bearing 16 onto the main bearing cap 14. Install the main bearing cap to the crankcase while tapping it with a soft hammer. The thrust plates 17 should also be installed to the front and rear of the rear main bearing cap.

NOTE : 1. The lug of the lower main bearing should be on the same side as the lug of the upper main bearing.

2. Install both thrust plates with the oil grooveless surface toward the rear main bearing cap.

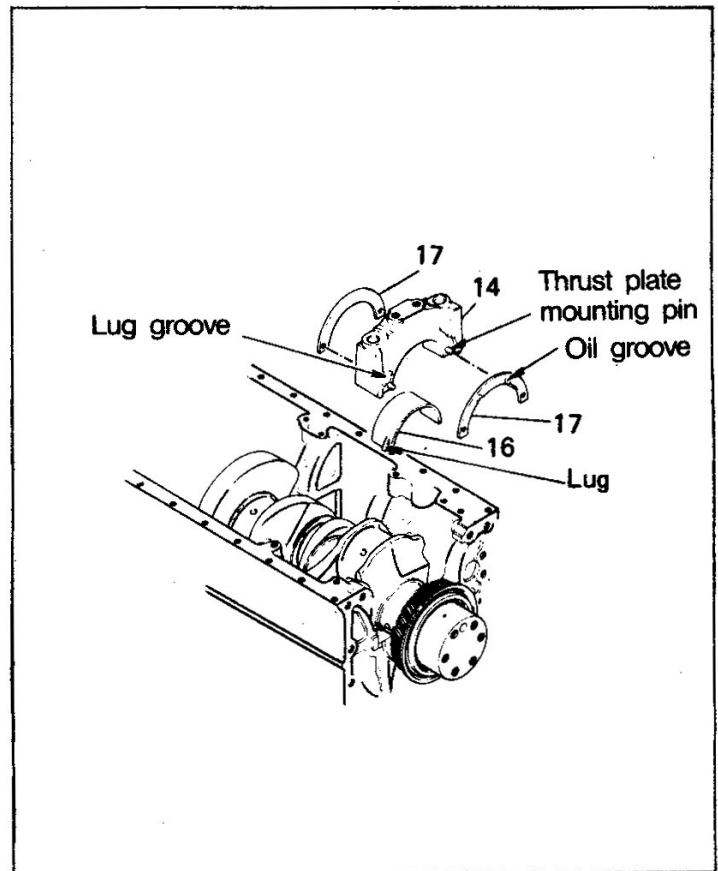

- (6) Tighten the main bearing cap to the specified torque.

After reassembly, check to ensure that the crankshaft can be turned lightly by hand. Check to ensure that the crankshaft end play has the nominal dimension. Refer to Para. 7-1-3(6).

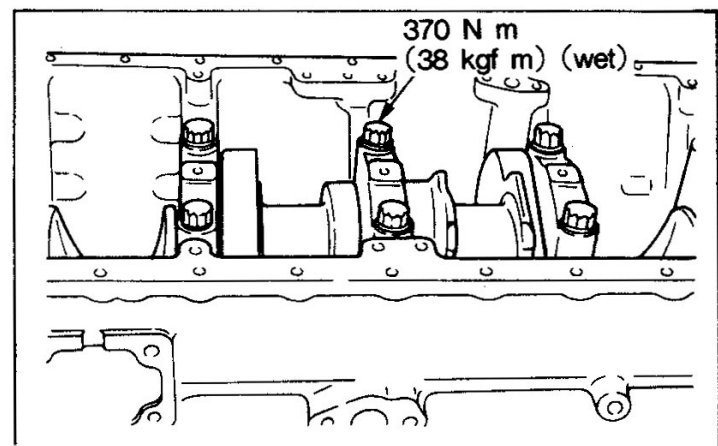

(7) Reassembly of Piston and Connecting Rod

- (a) When the piston 3 and connecting rod 9 are installed, direct them as shown.
- (b) Insert the piston pin 8 to couple the piston and connecting rod.

Fit the snap ring 7 to prevent the piston pin from slipping out of position.

If the piston and piston pin are hard to insert, heat the piston with a piston heater or in hot water.

NOTE : The parts for an engine must be of the same weight mark.

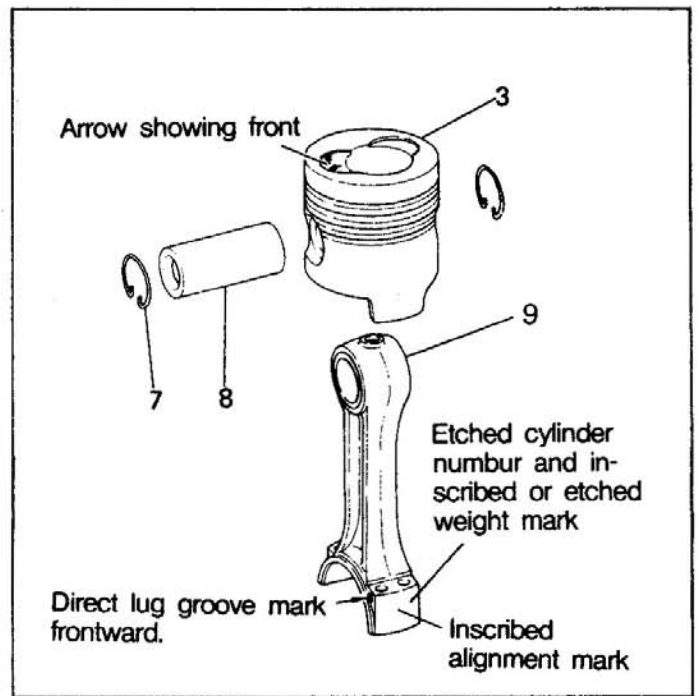

Weight marks

Heavy ← → Light

A B C D E F G H J K

- (c) Using Piston Ring Tool (special tool), install the piston rings in the following sequence.

- 6 Oil ring
- 5 2nd compression ring
- 4 1st compression ring

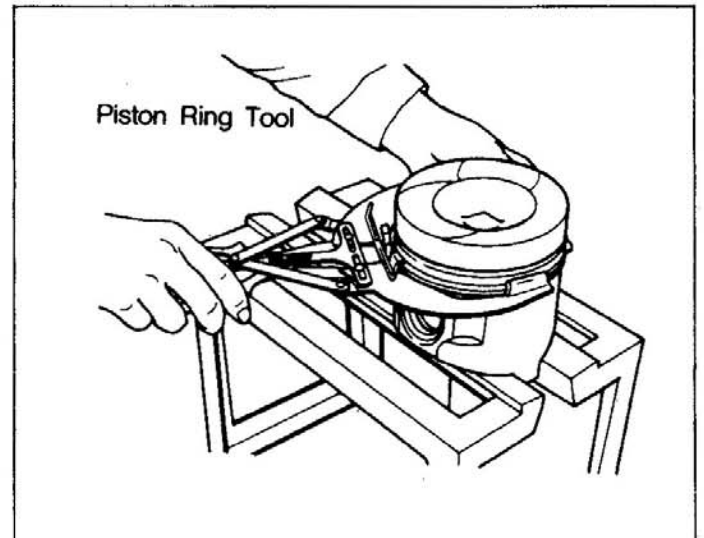

Install the piston ring with the manufacturer's mark at the open end of the ring upward.

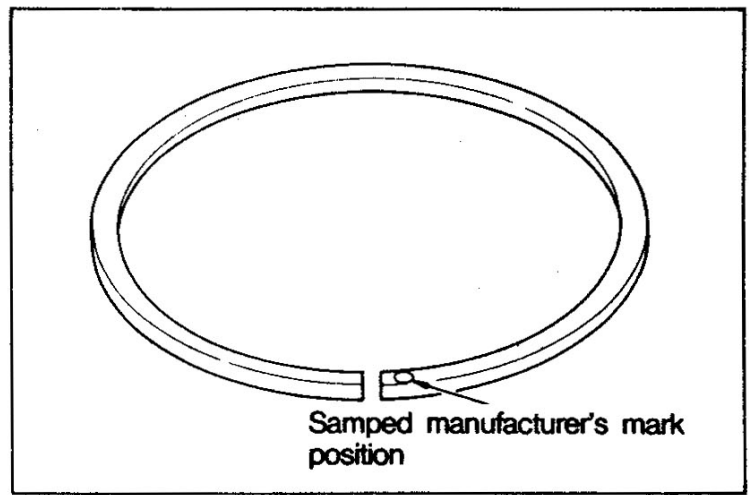

Direct the open ends of the piston rings as shown.

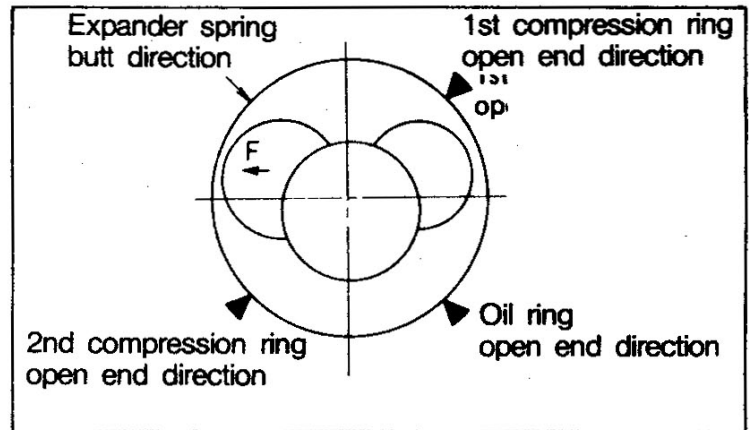

(d) Fit the oil-holed upper connecting rod bearing 2 on the connecting rod in such a way that the oil hole will match the oil hole in the connecting rod, and insert the piston into the cylinder liner, using a special tool (Piston Guide).

NOTE : 1. Assemble the piston and connecting rod so that the arrow mark on the top of the piston will be directed toward the front.

2. Make sure that the open ends of the piston rings do nt change their directions.

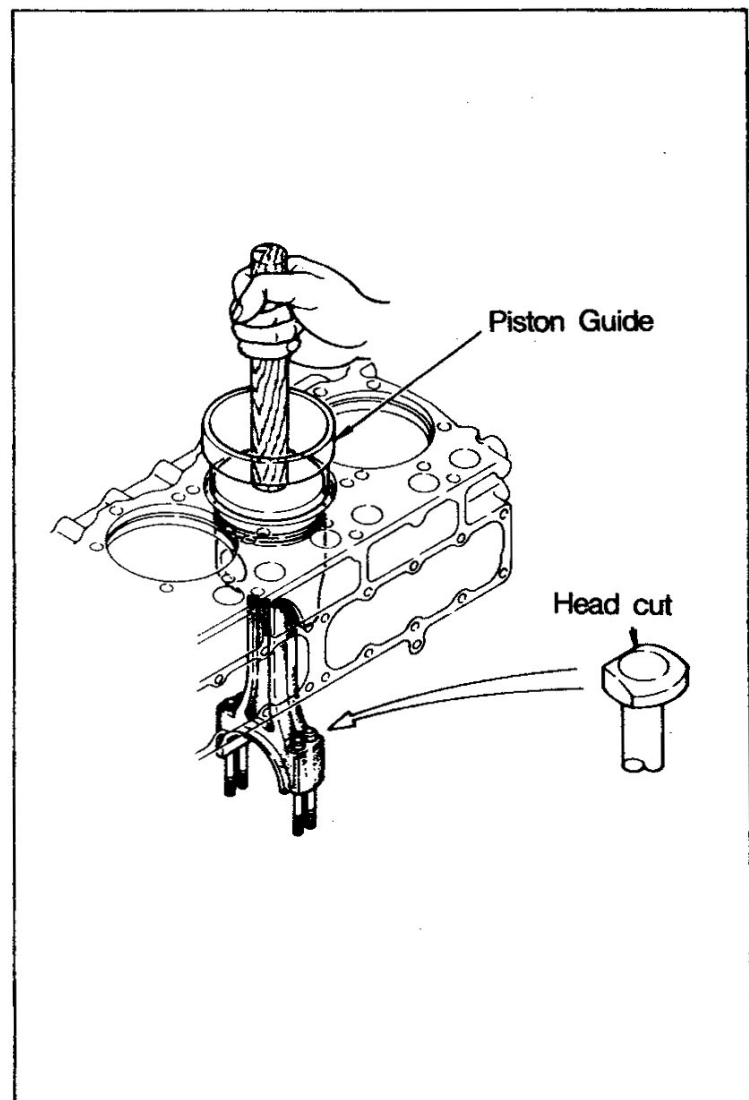

3. When the connecting rod is inserted, be sure not to damage the cylinder liner and crankshaft pin.
4. The notched portion of bolt head should be directed toward the connecting rod.
5. The connecting rod bearings are of two kinds, the upper and lower bearings. Assemble by fitting the oil-holed upper bearing on the connecting rod with the oil holes in alignment and by fitting the lower bearing without an oil hole in the connecting rod cap.

- (e) Fit the lower connecting rod bearing 2 without an oil hole in the connecting rod cap 1 and tighten the cap to the connecting rod to the specified torque.

NOTE : The lug side of connecting rod and the lug side of connecting rod cap should be in the same direction.

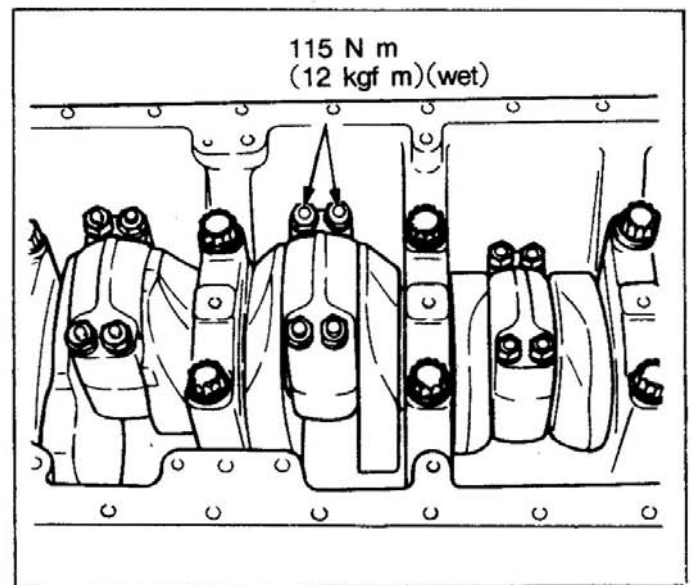

- (f) Check the connecting rod end play. Refer to Para. 7-1-3(2).
- (g) Check the projection of the piston. Refer to Para. 7-1-3(1).

- (8) Fit the seal plate 13 and oil seal 12 into the front cover 11 and install the front cover 11 to the crankcase.

NOTE : 1. Apply engine oil to the oil seal lips.

2. Check to ensure that the front slinger pressed into the crankshaft is free from deformation.

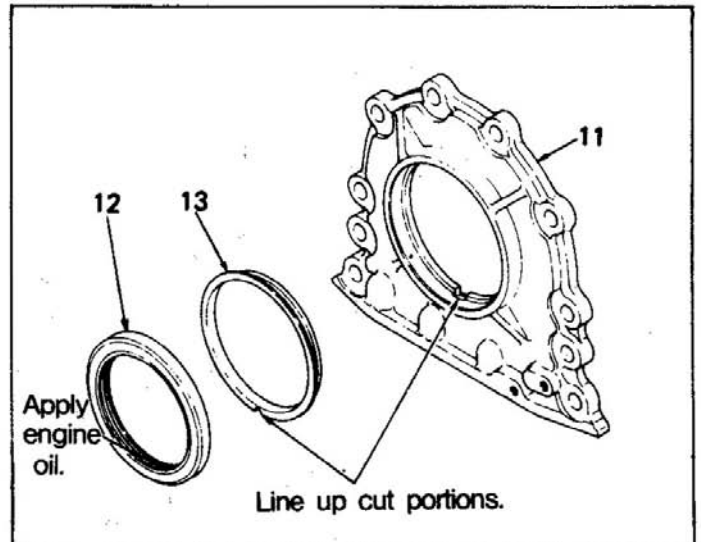

- (9) Tighten the crankshaft pulley 10 to the specified torque.

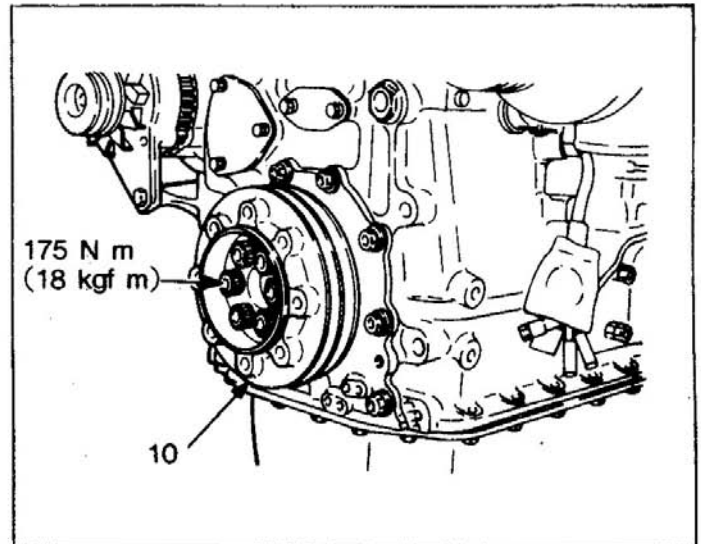

7-3-2 Flywheel, Timing Gear and Camshaft

NV...Nominal Value
 RL...Repair Limit
 SL...Service Limit

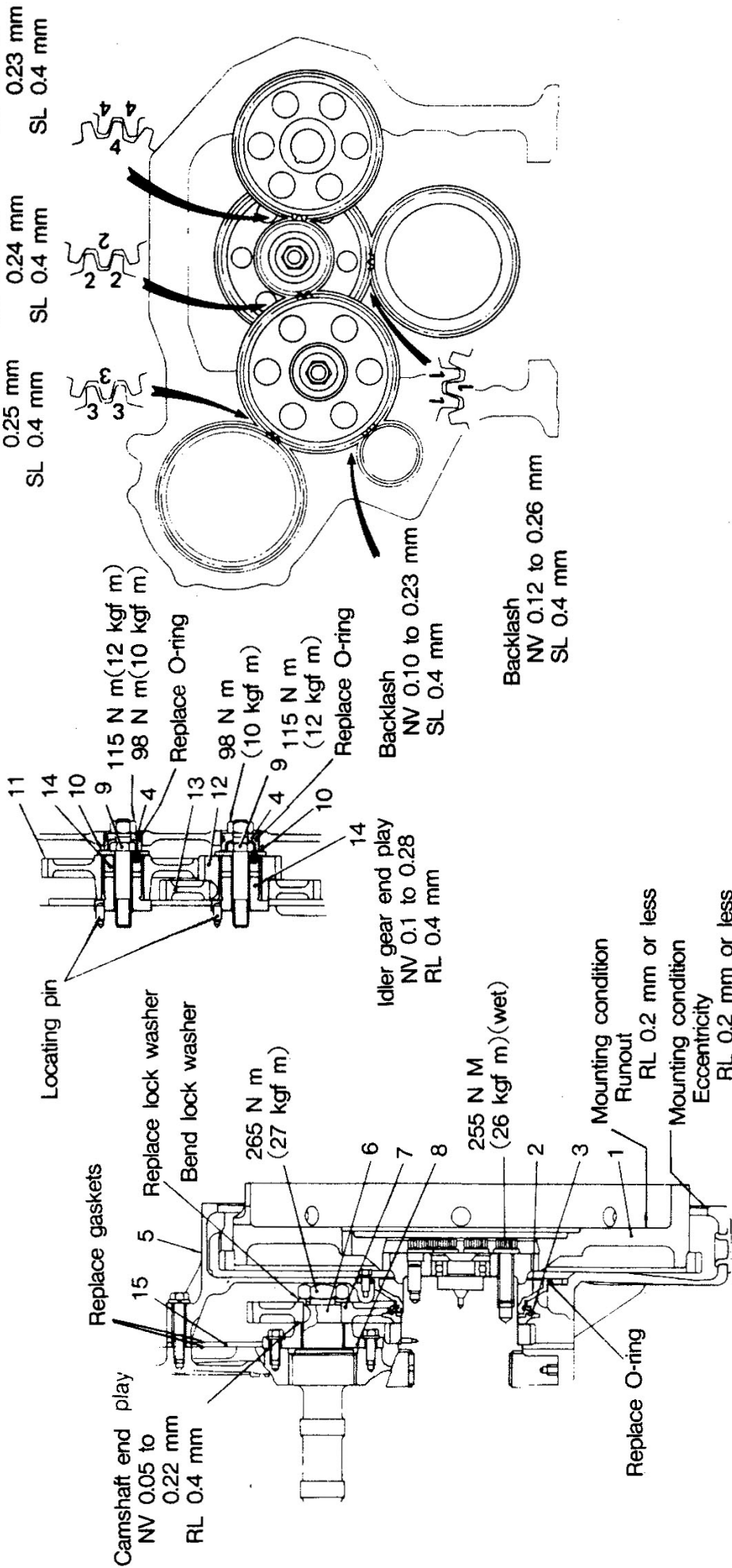

Assembling sequence



- (1) Install the rear plate 15 to the crankcase rear end.

The bottom of gasket installed between the rear plate and crankcase will protrude. After the flywheel housing has been installed, cut away the protruding portion.

NOTE : Do not apply sealant to the joining surfaces of the rear plate and crankcase.

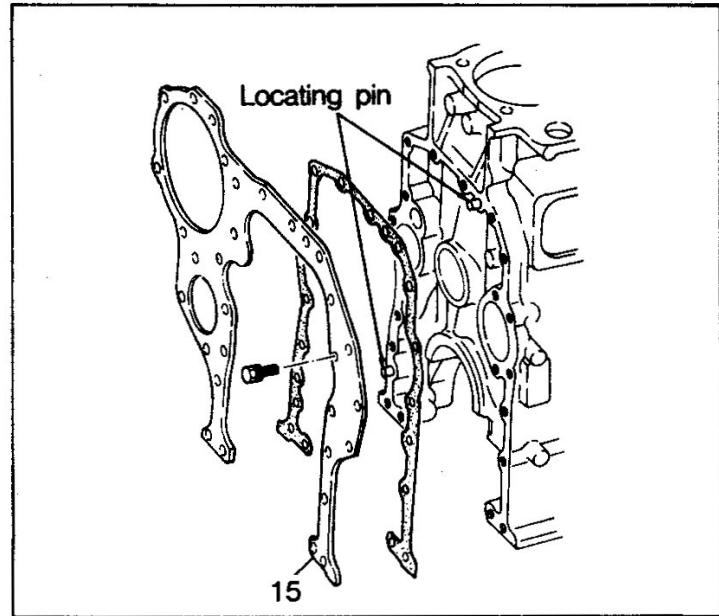

- (2) Install the idler gears in the following sequence.

- 14 Idler shaft
- 13 Idler gear "B"
- 12 Idler gear "A"
- 11 Idler gear "C"
- 10 Thrust plate
- 9 Idler shaft bolt

When the idler gears are installed, make sure that the alignment marks are in alignment.

Tighten the idler shaft bolt to the specified torque.

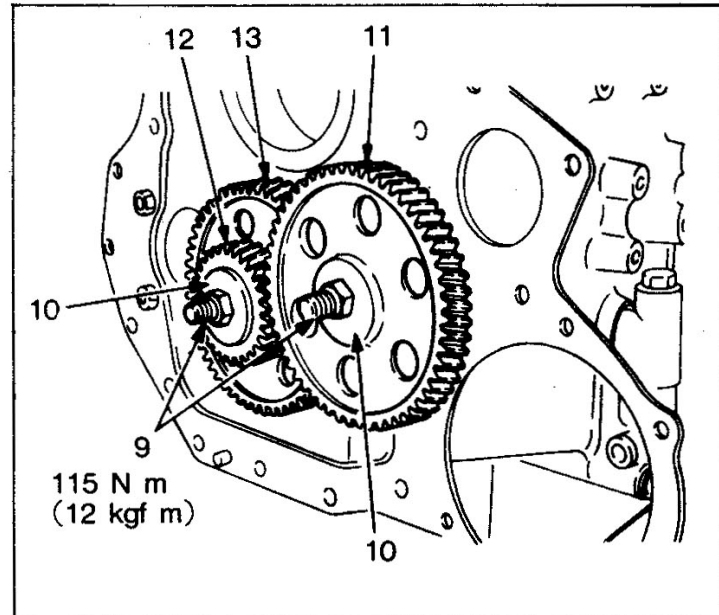

- (3) Install the thrust plate 8 and camshaft gear 7 to the camshaft 6.

The gear mounting nut should be tightened to the specified torque.

As for the lock washer, make sure that its claws are fitted and positively bent toward the nut.

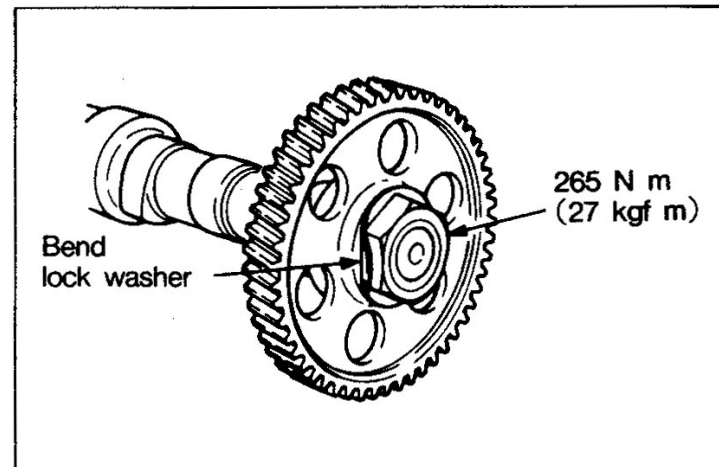

(4) Install the camshaft.

NOTE : 1. When the camshaft is inserted, take care not to damage the camshaft bushing.

2. When the idler gears and camshaft gear are installed, make sure that their alignment marks are in alignment.

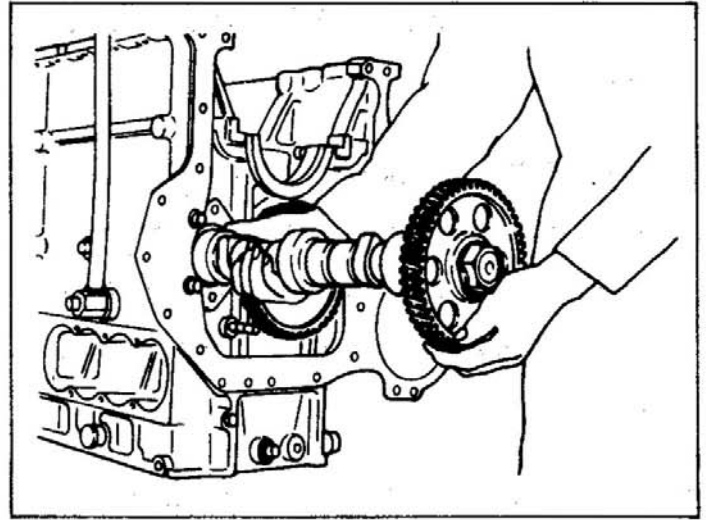

(5) Check the camshaft gear and idler gear end play. Refer to Para. 7-1-2(4).

(6) Check the backlash of each gear. Refer to Para 7-1-2(3).

(7) Install the flywheel housing 5 to the crankcase by tightening to the specified torque.

Measure the mounting condition (eccentricity) at the flywheel housing joint. If the pointer of a dial indicator deflects beyond the repair limit, loosen the bolts and lightly strike the housing to correct the mounting condition.

NOTE : 1. The protruding bottom ends of the gaskets between the rear plate and crankcase and between the rear plate and flywheel housing should be cut away.

2. Do not apply sealant to the mounting surfaces of the rear plate and flywheel housing.

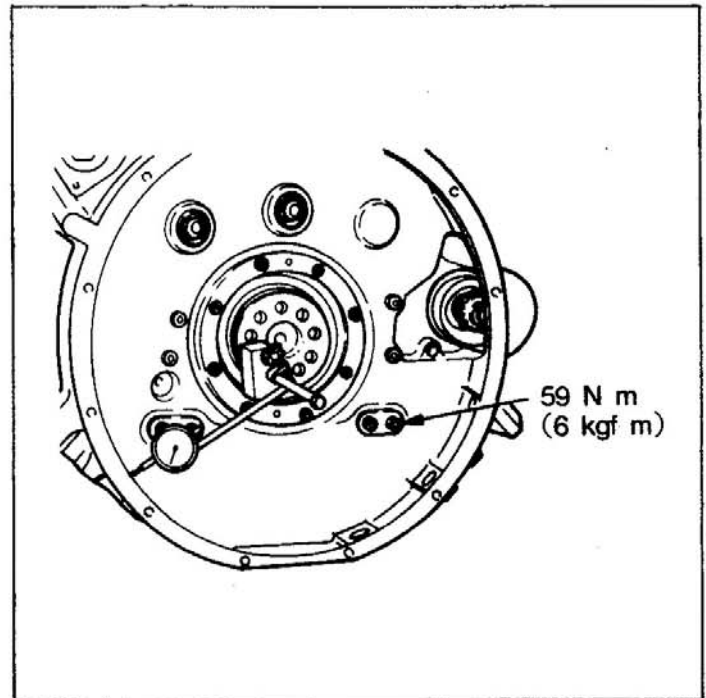

- (8) Install the collar 4 to the idler shaft bolt and tighten the nut to the specified torque.
- (9) Install the oil seal retainer 2 in which the oil seal 3 was pressed to the flywheel housing.

NOTE : Apply engine oil to the sliding surface of the oil seal.

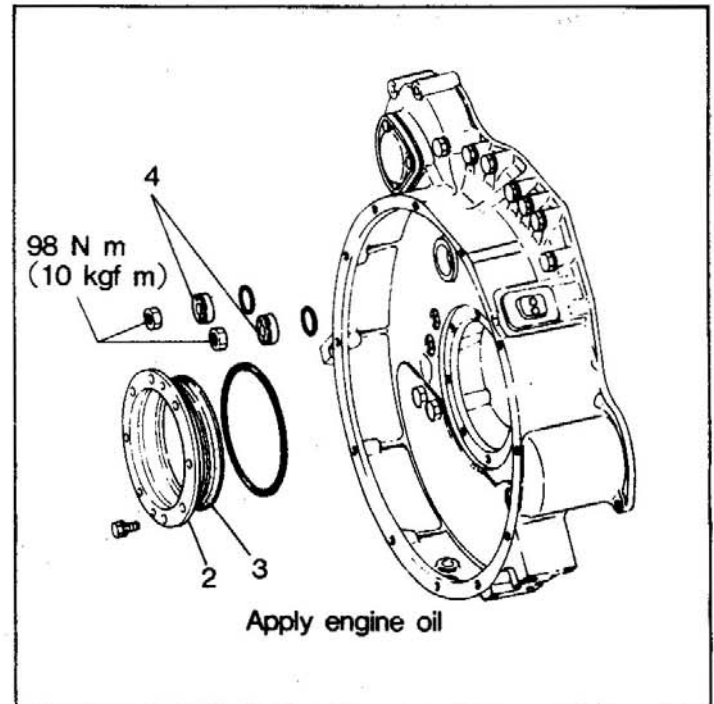

- (10) Install the flywheel 1 to the crankshaft and tighten the bolt to the specified torque.

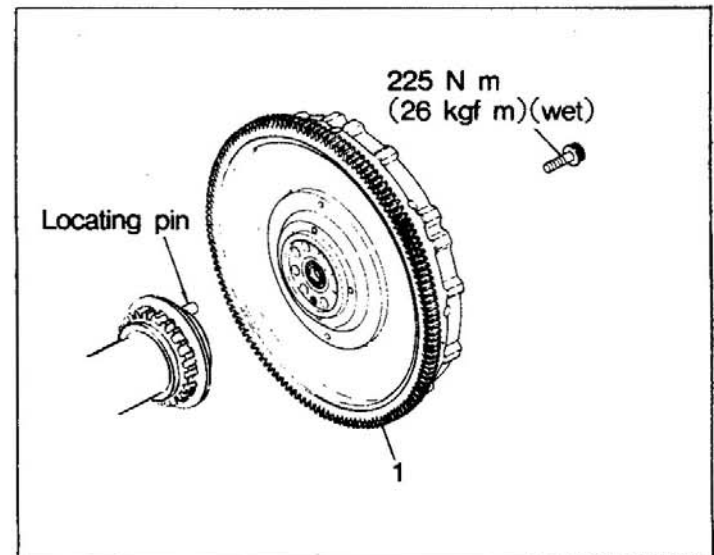

- (11) Measure the flywheel mounting condition (runout). If the pointer of the dial indicator deflects beyond the repair limit, check the bolt tightness or mounting surface.

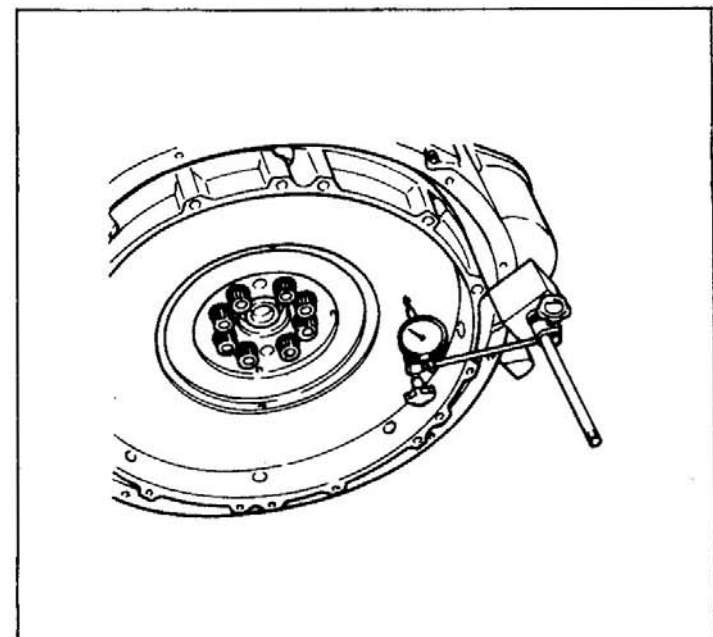

7-3-3 Cylinder Head and Valve Mechanism

* Install valve spring with the side painted in green directed toward cylinder head.

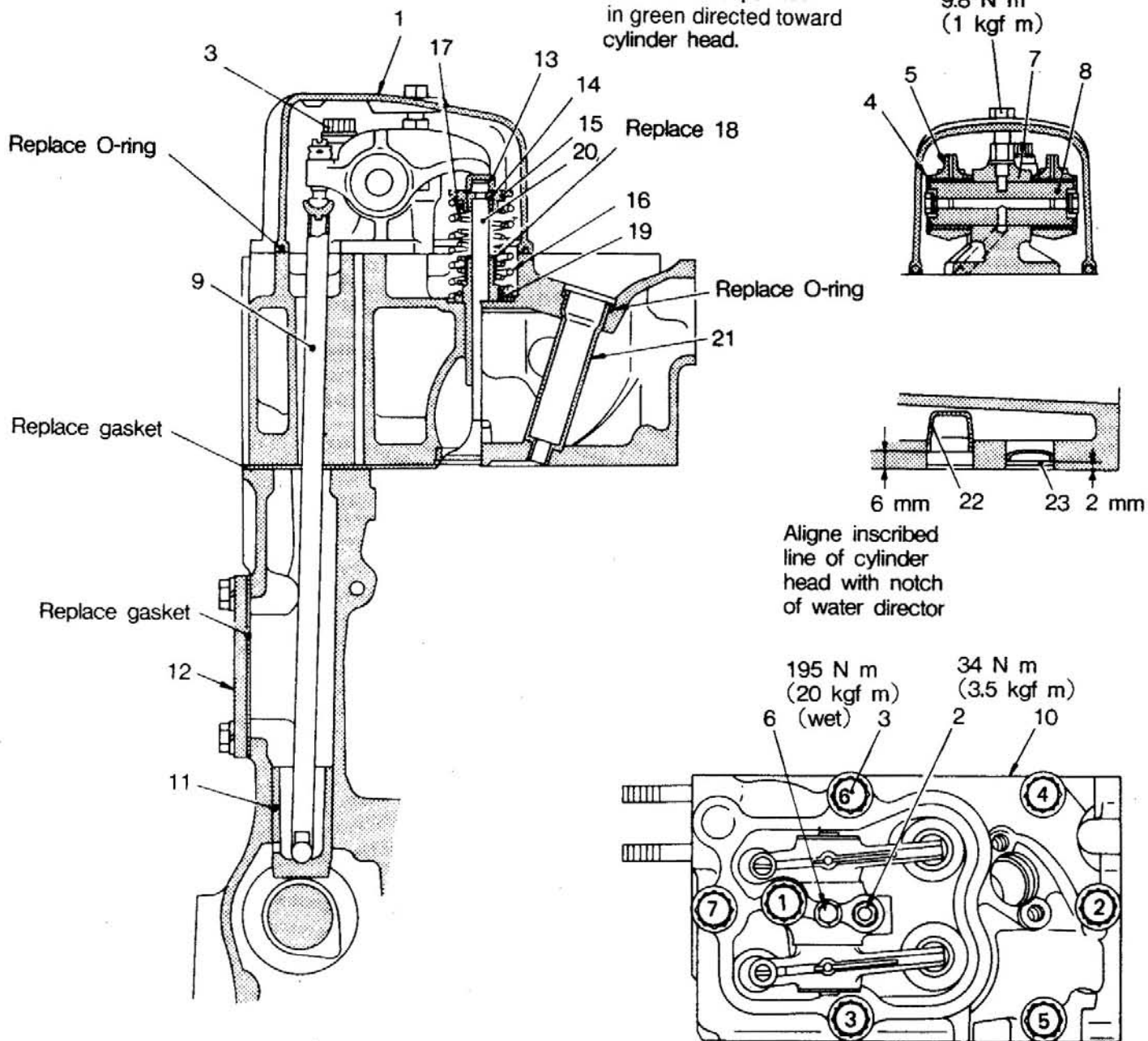

Assembling sequence

23→22→21→20→18→19→17→16→16→14→13→
12→11→10→9→8→7→6→5→4→3→2→1

- (1) Install the sealing cap 23 and water director 22 in the cylinder head.

NOTE : Install the water director with its notch directed as shown.

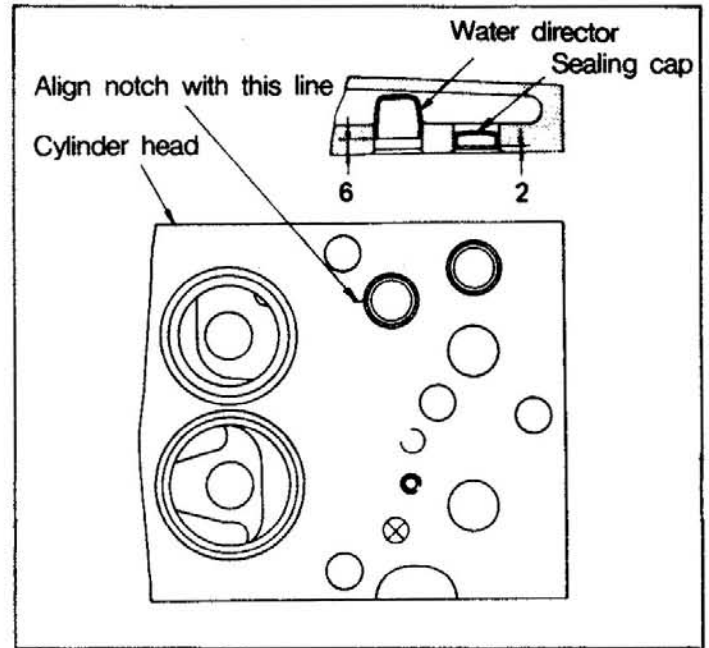

- (2) Installation of Nozzle Tube

- (a) Apply sealant to the end of the nozzle tube 21 and insert into the cylinder head together with the O-ring.
- (b) Using Flange(special tool), press the nozzle tube against the cylinder.
- (c) Apply engine oil to Stamp(special tool) and insert into the nozzle tube.

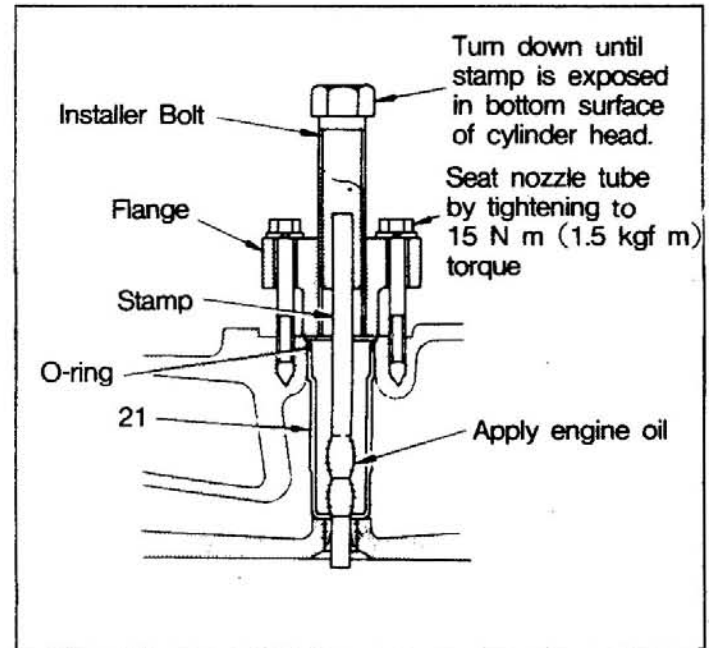

- (d) Thread Installer Bolt(special tool) to push the stamp until it can be removed from the bottom of the cylinder head.
- (e) After the nozzle tube has been installed, perform hydraulic test to check for water leaks.(Test pressure 195 kPa or 2 kgf/m²)

(3) Install the following parts.

20 Valve

18 Valve stem seal

The valve stem seal should be installed by applying engine oil to the lip and striking down Valve Stem Seal Installer (special tool) until it touches the cylinder head.

NOTE : 1. Before the valve is installed, apply a small amount of engine oil to the stem.

2. After installation, check to ensure that the valve stem seal spring has not been deformed or damaged.

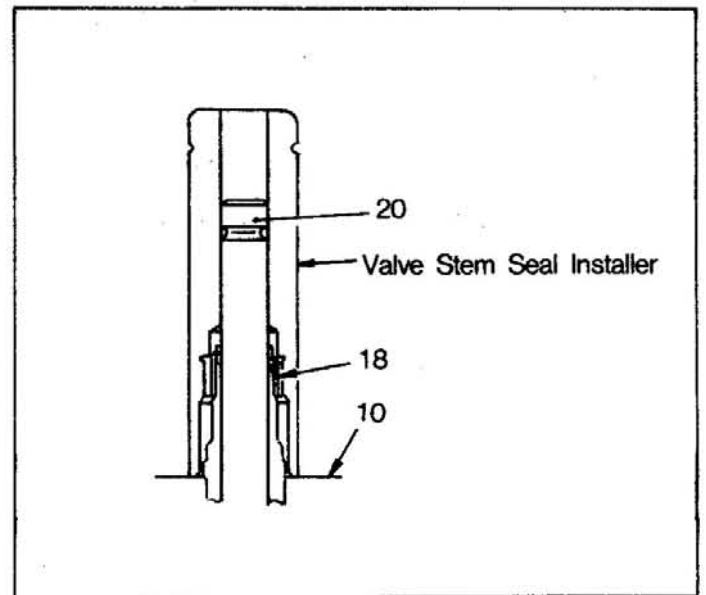

(4) Install the following parts.

19 Lower retainer

17 Inner valve spring

16 Outer valve spring

15 Upper retainer

14 Valve cotter

13 Valve cap

Install the valve cotter, while compressing the valve spring, using Valve Lifter (special tool).

NOTE : 1. Install the valve spring with the closely coiled portion (blue painted) toward the cylinder.

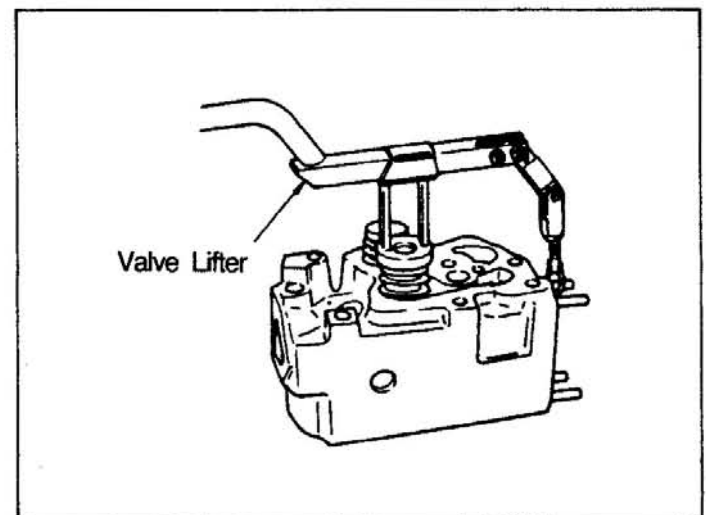

2. When the valve spring is compressed with the valve lifter, make sure that it is evenly compressed.

- (5) Insert the tappet 12 and install the crankcase side cover 11.

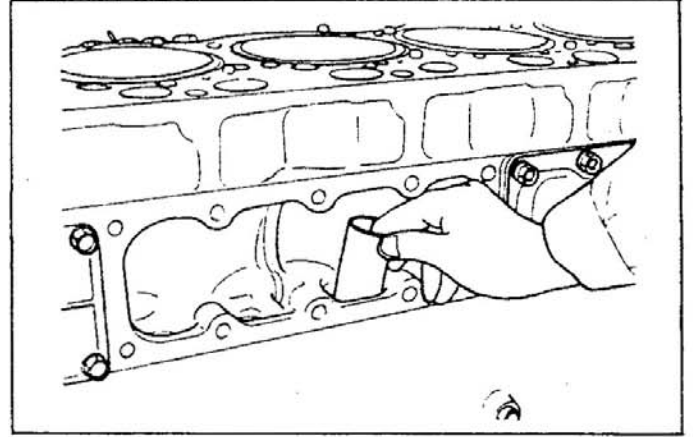

- (6) Seat the cylinder head 10 on the crankcase, while lining it up with the locating pin.

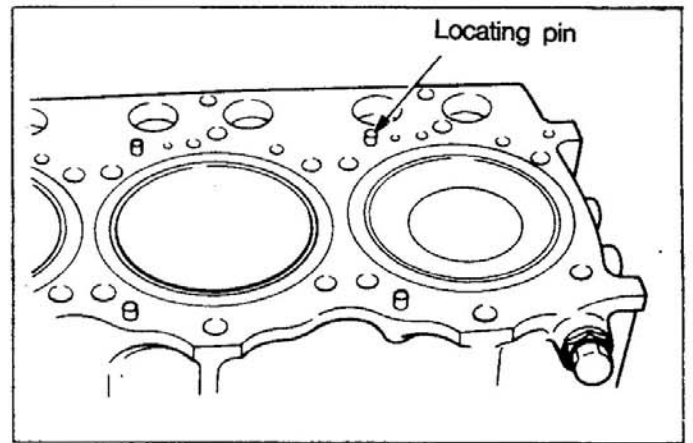

- (7) Assemble the rocker shaft bracket assembly.

- 8 Rocker shaft bracket
- 7 Rocker shaft
- 6 Set screw
- 5 Rocker
- 4 Thrust plate

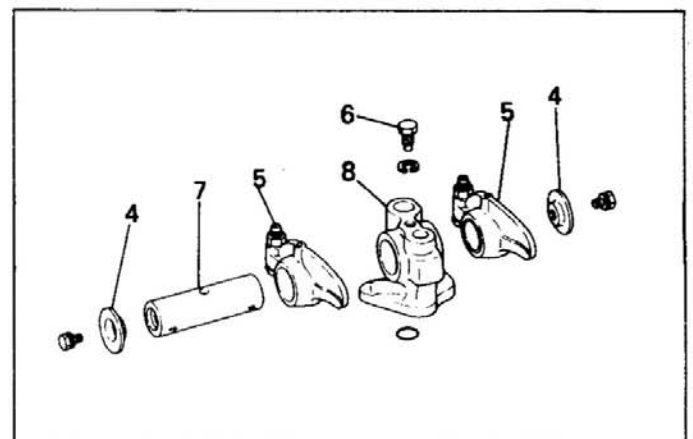

(8) Install the push rod 9 and rocker shaft bracket assembly.

NOTE : Install a new O-ring to the bottom of the rocker shaft bracket.

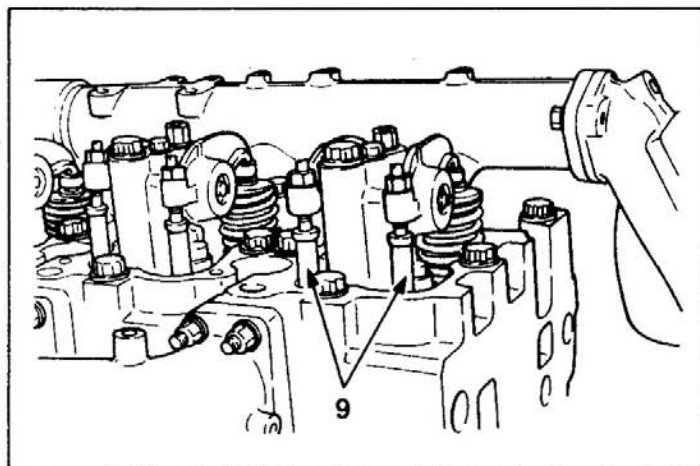

(9) Install the following parts.

- 3 Cylinder head bolt
- 2 Rocker bracket mounting bolt
- 1 Rocker cover

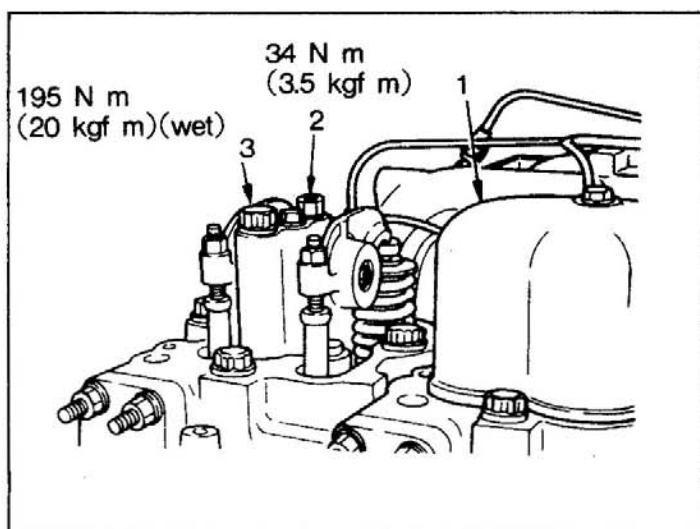

Temporarily turn down the cylinder head bolts in the sequence shown. As a final step, torque them to specifications.

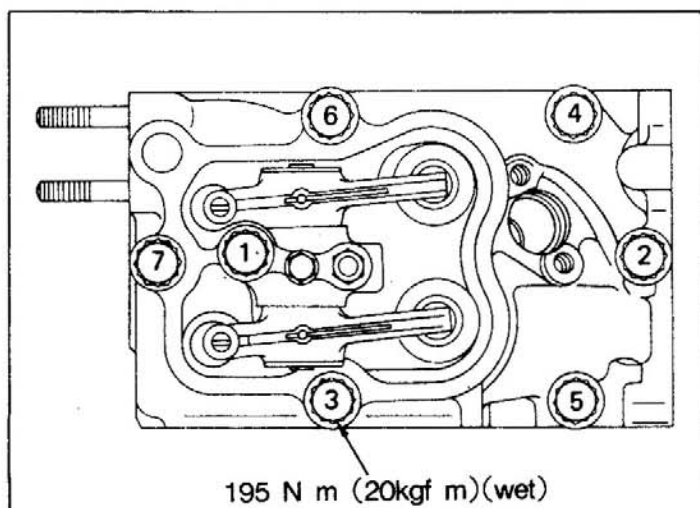

In servicing the inlet and exhaust system, use the following tools.

Special Tool Name	Part No.	Use
Socket	MH061242	For exhaust manifold attaching nuts
General tools and measuring tools Snap ring expander Plastic hammer Torque wrench Chisel Dial gauge Micrometer Thickness gauge		For overhaul of turbocharger

8-1 INLET MANIFOLD

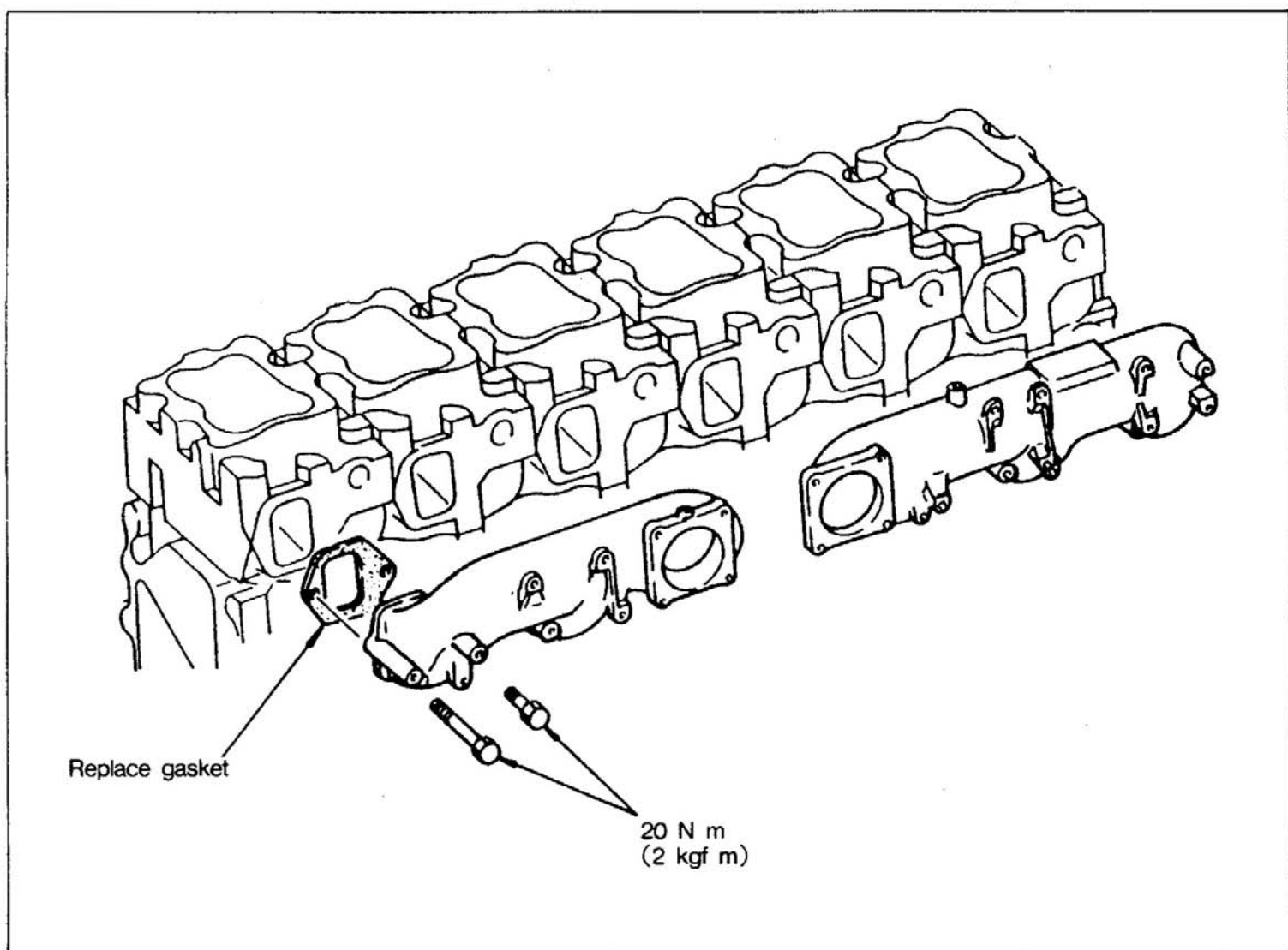

8-2 AIR CLEANER

8-2-1 Disassembly and Reassembly

(1) Single Element Type

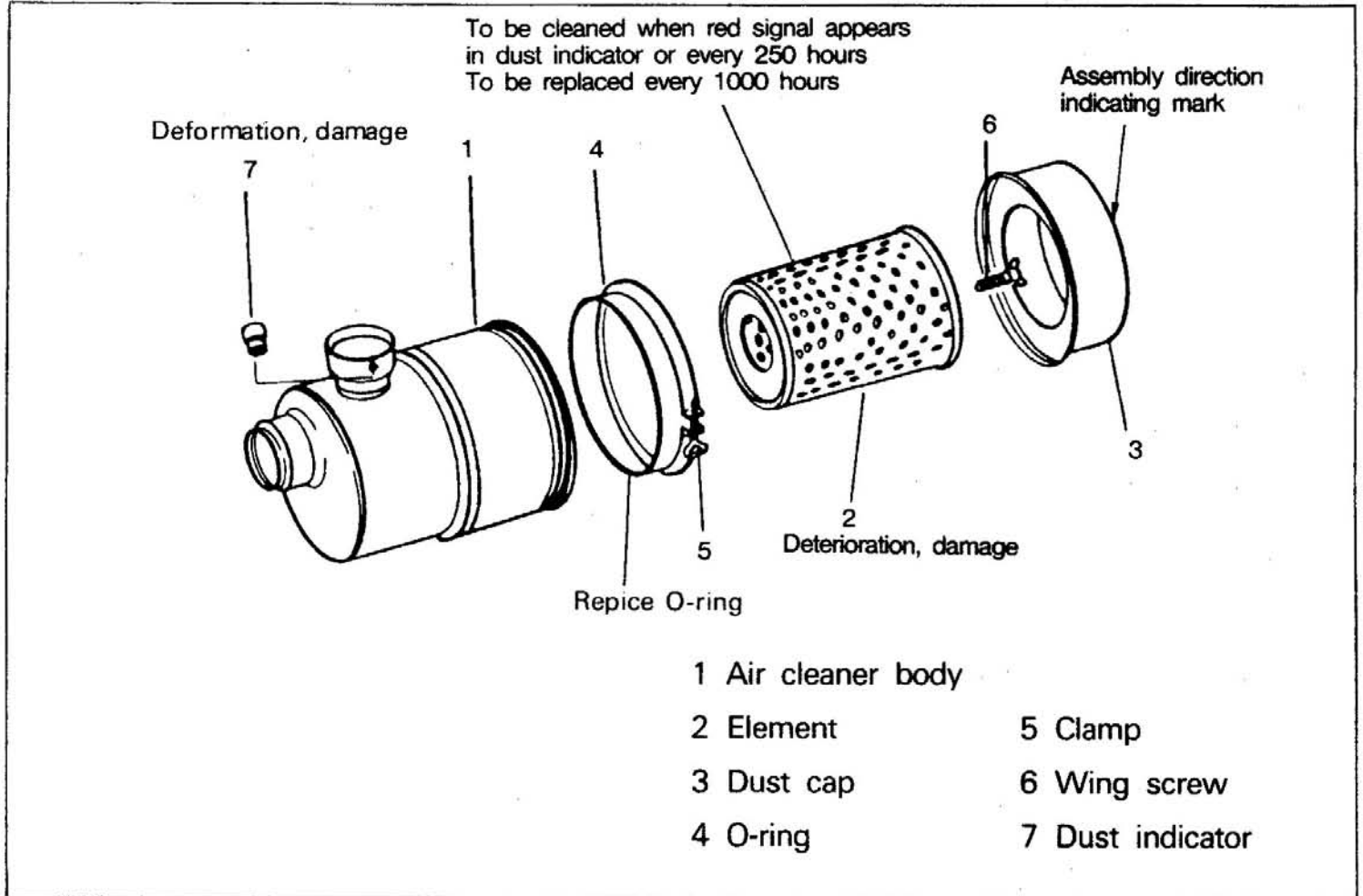

8-2-2 Inspection and Cleaning

(1) Dry Dust

If there is dry dust on the element, clean the dust by blowing 685kPa(7 kgf/m²) or lower compressed air against the element.

Blow the compressed air from inside the element up and down along the frills of the filter paper and clean the whole element evenly.

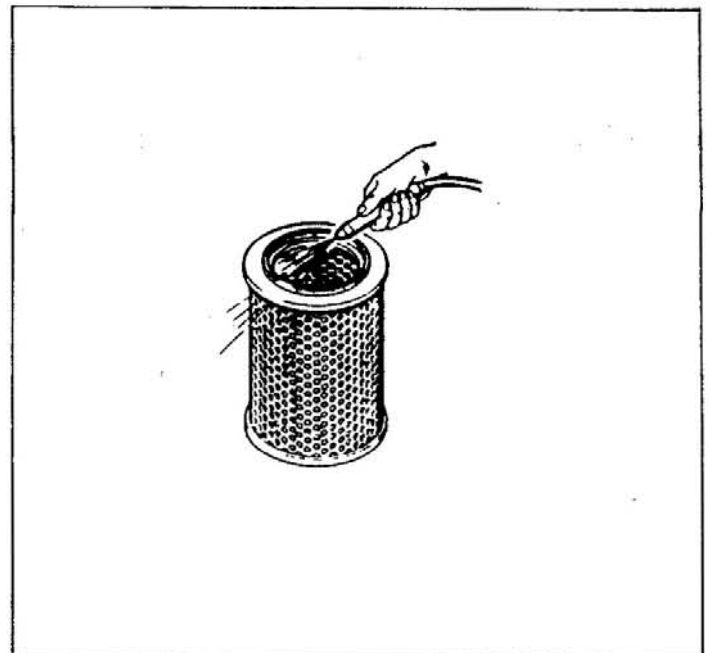

NOTE : Do not strike the element or strike it against a hard object to loosen the dust.

(2) Moist Dust

If the element has dust moistened with oil smoke or soot, wash the element, using the element cleaner ND-1500

Add 15 g of the cleaner per liter of approx. 40°C hot water, stir, immerse the element for about 30 minutes, and wash.

After the element has been washed, rinse it in water (275 kPa or 2.8kgf/m² or lower water pressure) and let it dry in a well-ventilated place.

An element washed four times should be replaced regardless of the time in service.

NOTE : When the element has to be quickly dried, an electric fan, etc. may be used, but do not use compressed air or fire.

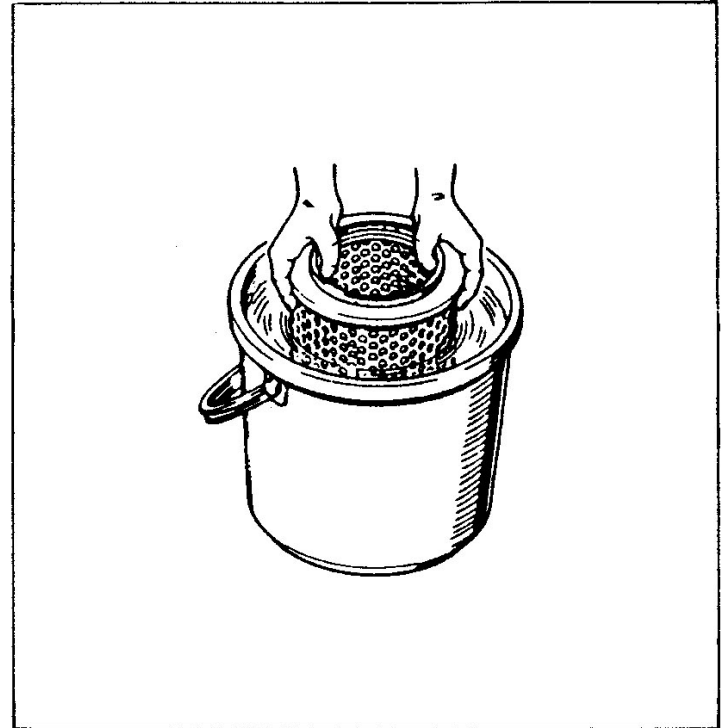

(3) Inspection of Element

After the element has been cleaned, put an electric lamp inside the element to check for damage and pin holes. If there are thin portions in the filter paper, replace the element. If the packing on the top surface of the element is broken, replace the packing.

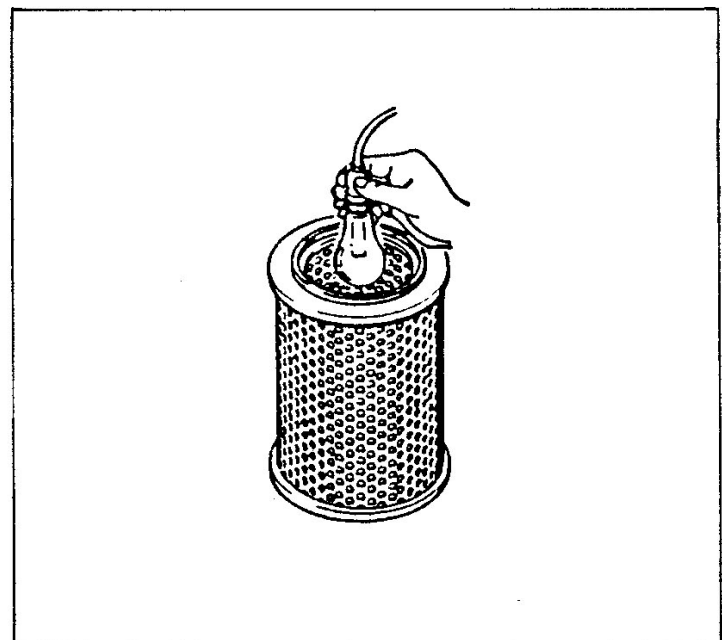

8-2-3 Inspection of Dust Indicator

Start the engine and slowly close the suction port of the air cleaner to increase the negative pressure. If the red signal appears in the dust indicator, the dust indicator is good.

The simplest checking method is to put the suction port in your mouth and draw a breath. If the red signal appears at this time, then the dust indicator is good.

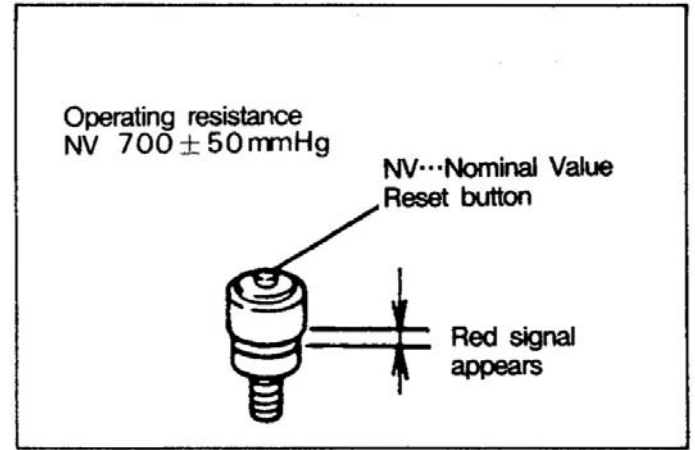

8-3 EXHAUST MANIFOLD

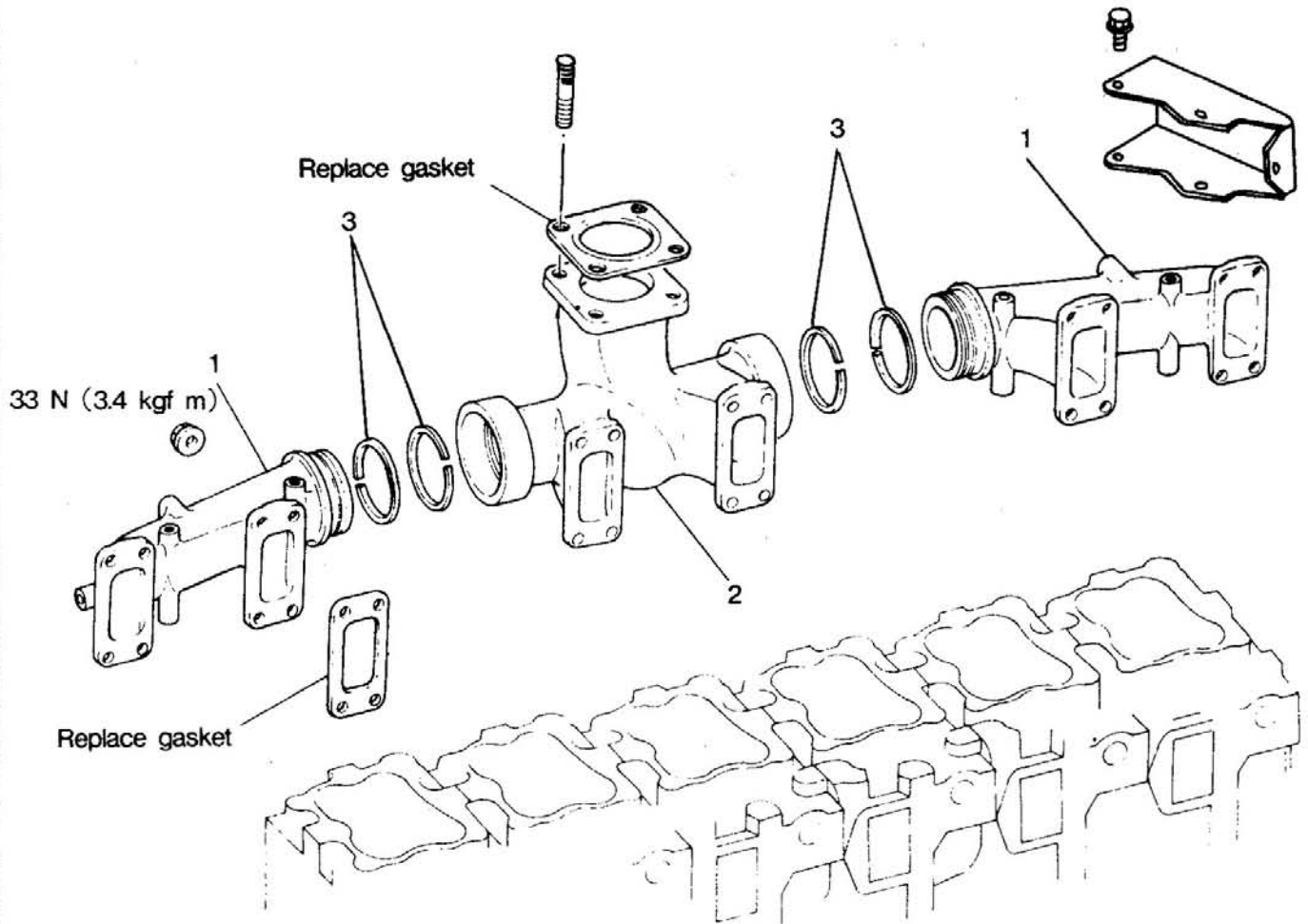

- 1 Exhaust manifold
- 2 Center exhaust manifold
- 3 Exhaust manifold ring

8-4 TURBOCHARGER

8-4-1 Disassembly

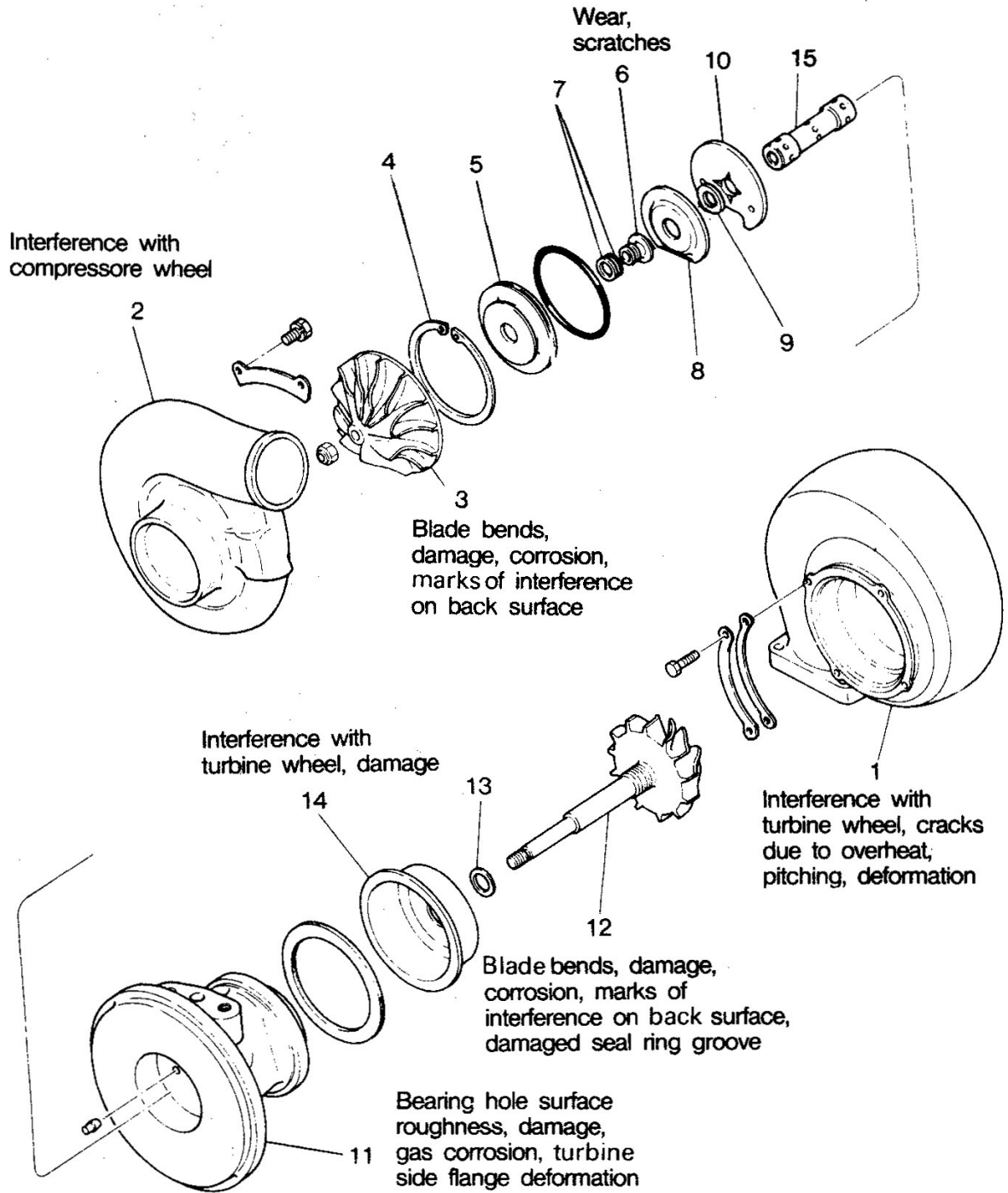

- | | | |
|--------------------|-------------------|--------------------------|
| 1 Turbine housing | 6 Thrust sleeve | 11 Bearing housing |
| 2 Compressor cover | 7 Piston ring | 12 Turbine wheel shaft |
| 3 Compressor wheel | 8 Oil deflector | 13 Piston ring |
| 4 Snap ring | 9 Thrust ring | 14 Turbine backing plate |
| 5 Insert | 10 Thrust bearing | 15 Bearing |

(1) Hold the flange portion of the turbine housing in a vice.

NOTE : Make sure to put alignment marks on the compressor cover, bearing housing and turbine housing for correct positional relationships at reassembly.

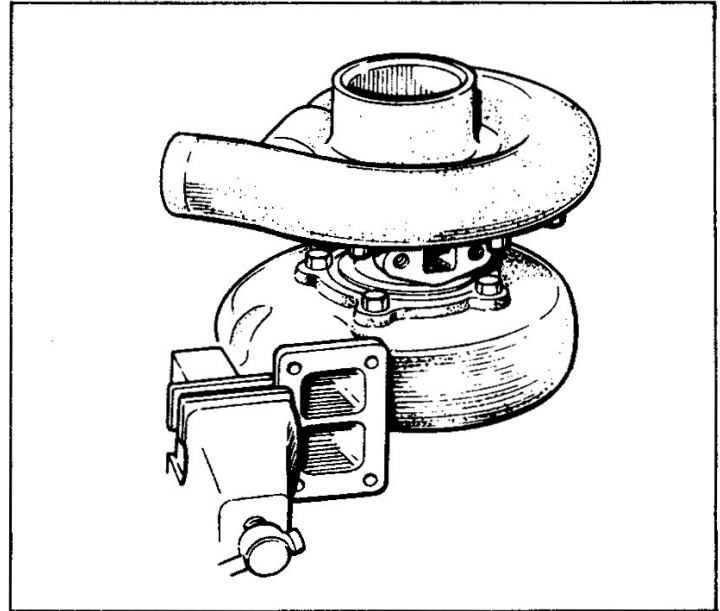

(2) Remove the turbine housing 1.

NOTE : Do not drop and strike the compressor wheel and turbine wheel, as their blades are readily bent.

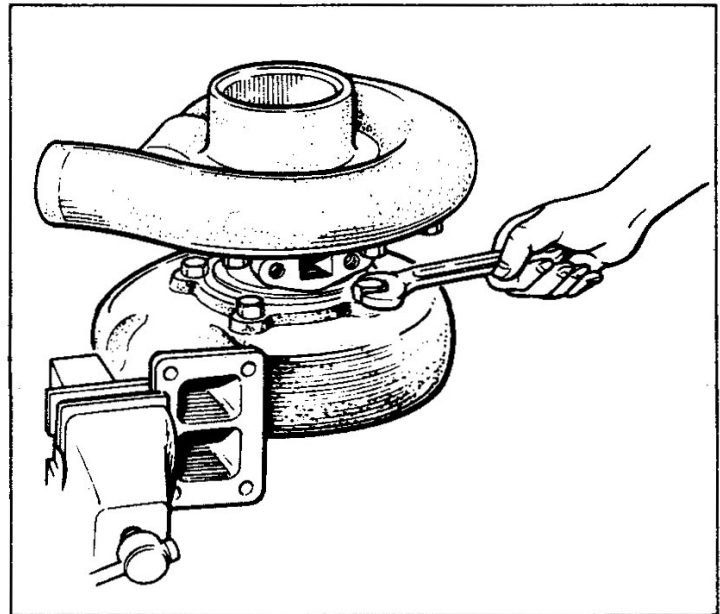

(3) Remove the compressor cover 2.

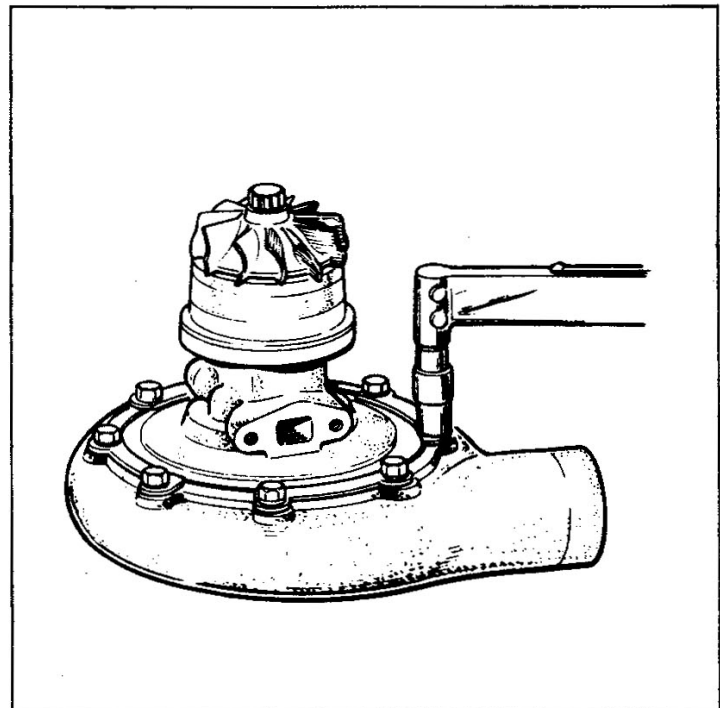

(4) Fit the core assembly detached from the compressor cover in the turbine housing. Hold the turbine housing end of the turbine wheel shaft to prevent its rotation and remove the following parts.

3 Compressor wheel

4 Snap ring

NOTE : If the compressor wheel has bent blades, do not attempt correcting the bend but replace parts.

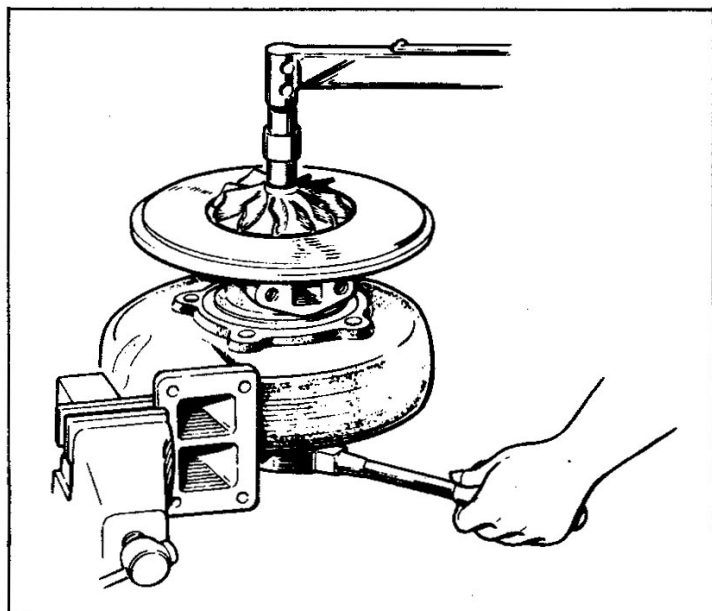

(5) Remove the following parts.

5 Insert

6 Thrust sleeve

7 Piston ring

8 Oil deflector

9 Thrust ring

10 Thrust bearing

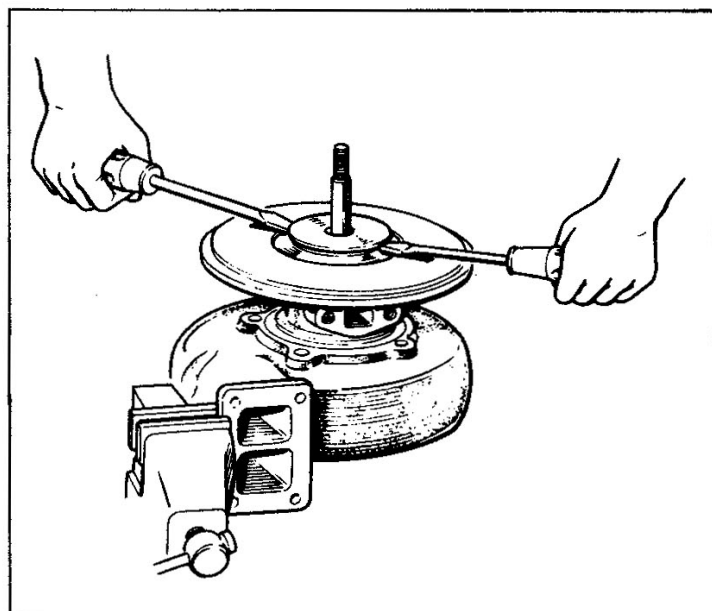

(6) Remove the bearing housing 11 from the turbine housing.

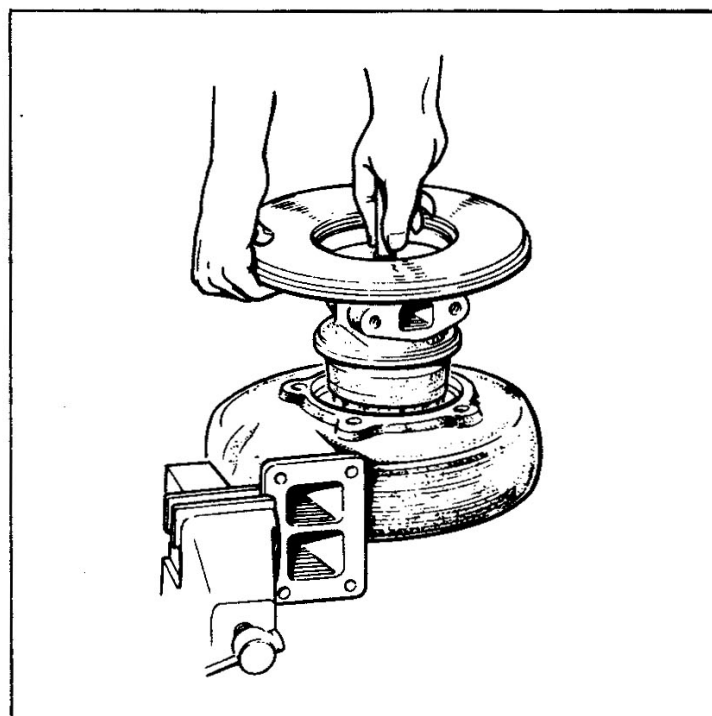

(7) Remove the following parts.

- 12 Turbine wheel shaft
- 13 Piston ring
- 14 Turbine backing plate
- 15 Bearing

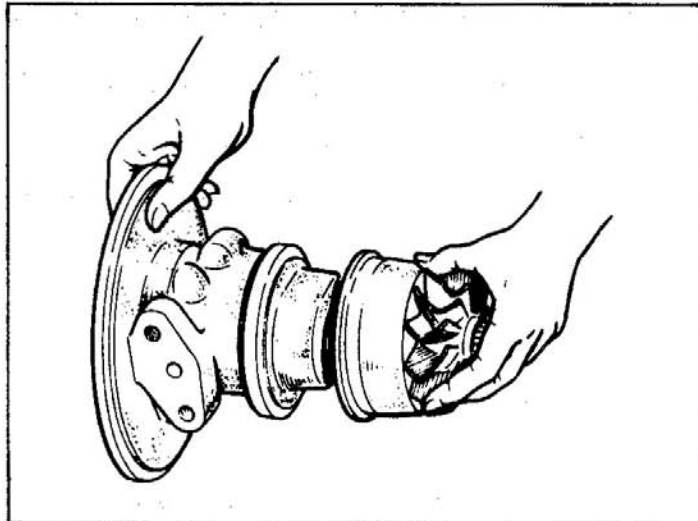

NOTE : 1. There are two pins driven into the turbine housing. Do not remove the pins.

2. Do not attempt correcting bent blades but replace them.

(1) Cleaning

Turbocharger manufacturers use a blasting equipment for cleaning parts at their workshops. As an alternative effective method for overhaul at the dealer's workshop, use the following procedures.

When a commercially available neutral detergent is used for cleaning, make sure that it does not contain corrosive component.

- (a) Before cleaning, visually check the condition of the parts. Check for burns, wear, etc. which could not be identified after washing.
- (b) Immerse all the parts in a non-inflammable solvent to clean oily contamination.

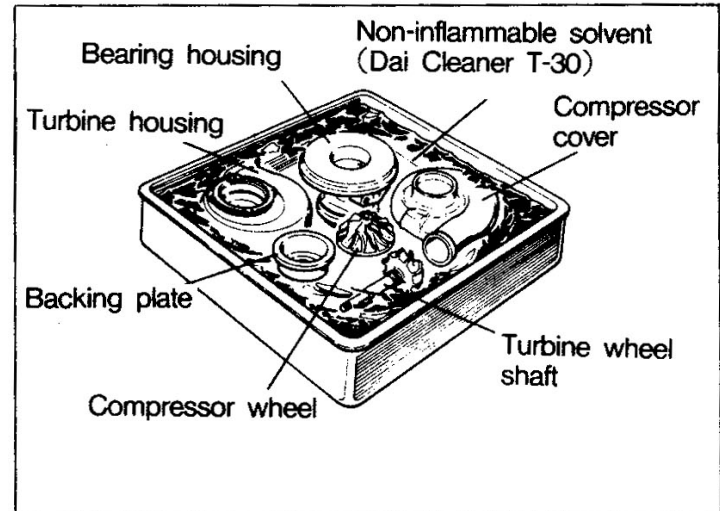

- (c) Blow clean compressed air against the entire internal and external surfaces.

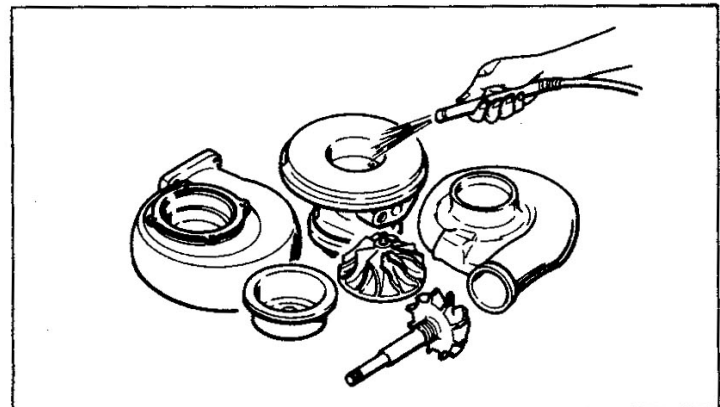

- (d) Clean deposits, using a plastic scraper or bristle brush.

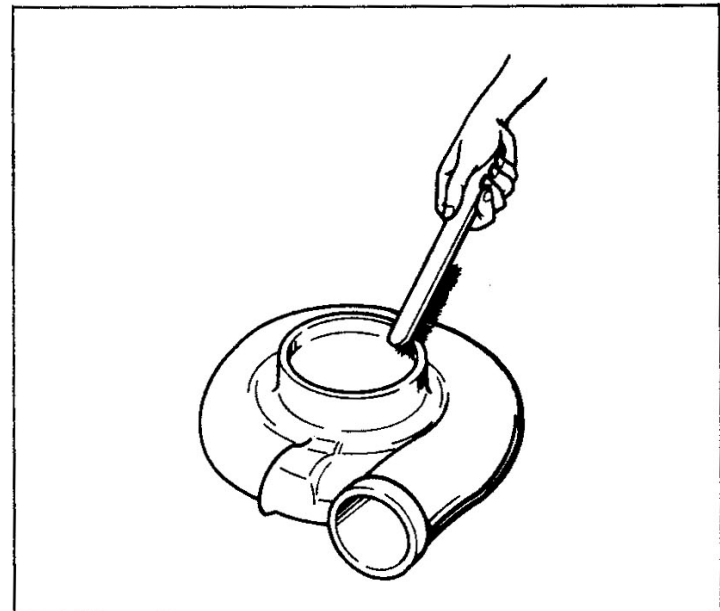

- (e) Blow clean compressed air again against the entire internal and external surfaces.

NOTE : The bearing housing and turbine wheel shaft should be re-immersed in a non-inflammable detergent after Step (d). After deposits have been removed, blow compressed air.

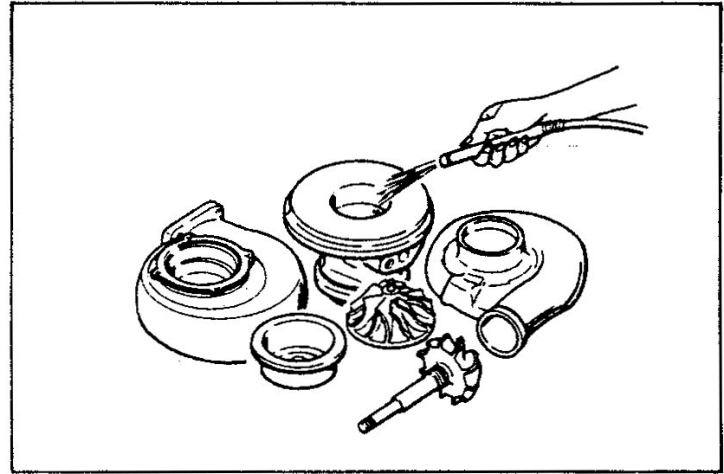

- (f) To prevent rust, apply engine oil to the entire internal and external surfaces of the bearing housing, turbine housing and turbine backing plate and the shaft portion of the turbine wheel shaft.

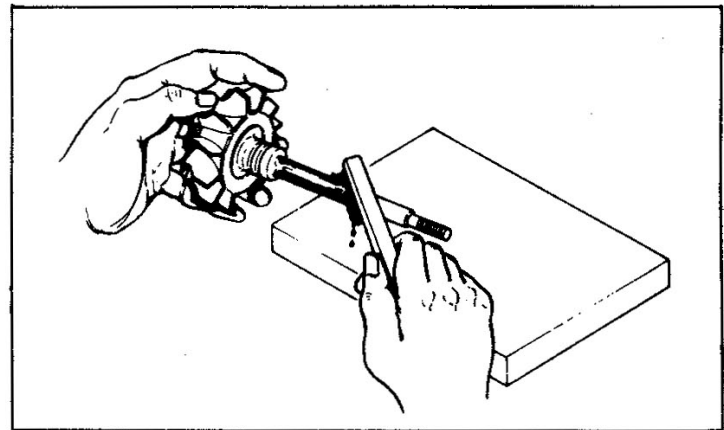

(2) Inspection

- (a) If the bearing hole diameter and piston ring hole diameter are beyond the service limit, replace the bearing housing.

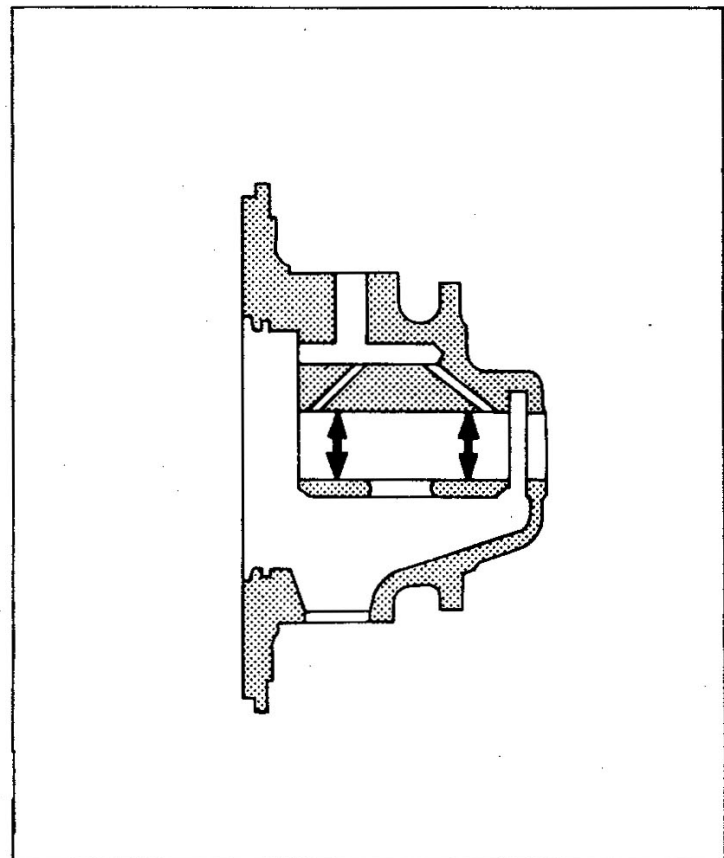

- (b) Measure the shaft journal diameter.
If the measured diameter is less than the service limit, replace the turbine wheel shaft.

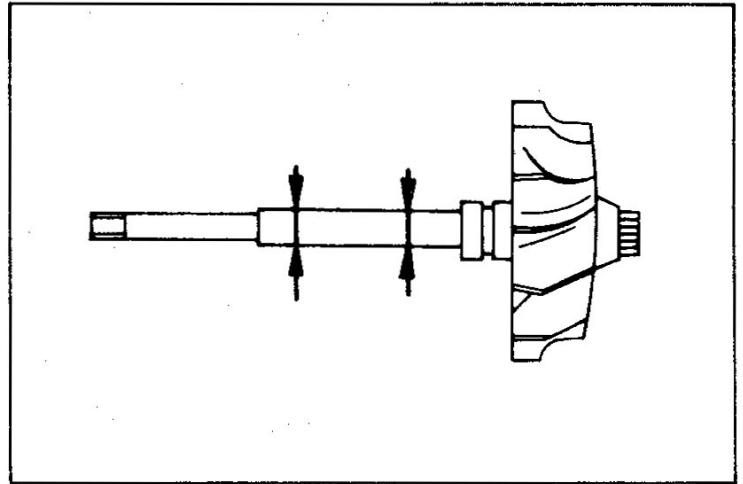

- (c) Set a dial indicator beside the threaded portion of the shaft to measure the bend.

If the deflection of the dial indicator is beyond the service limit, replace the turbine wheel shaft.

NOTE : Do not correct but replace a bent shaft.

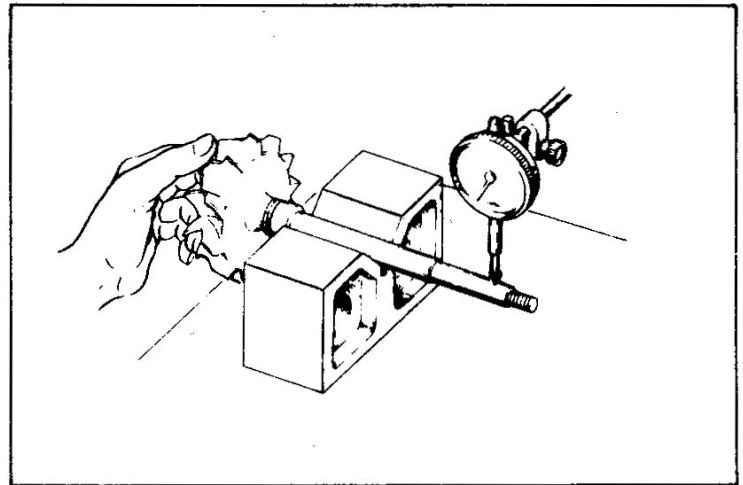

- (d) Insert

Insert a new piston ring securely in the bore in the insert and measure the end gap of the piston ring.

If the end gap is out of specification, replace the insert.

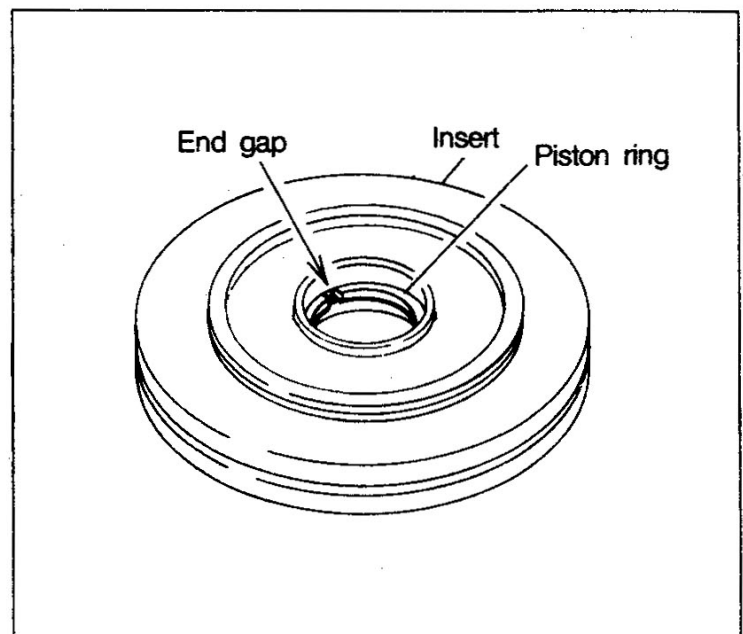

8-4-3 Reassembly

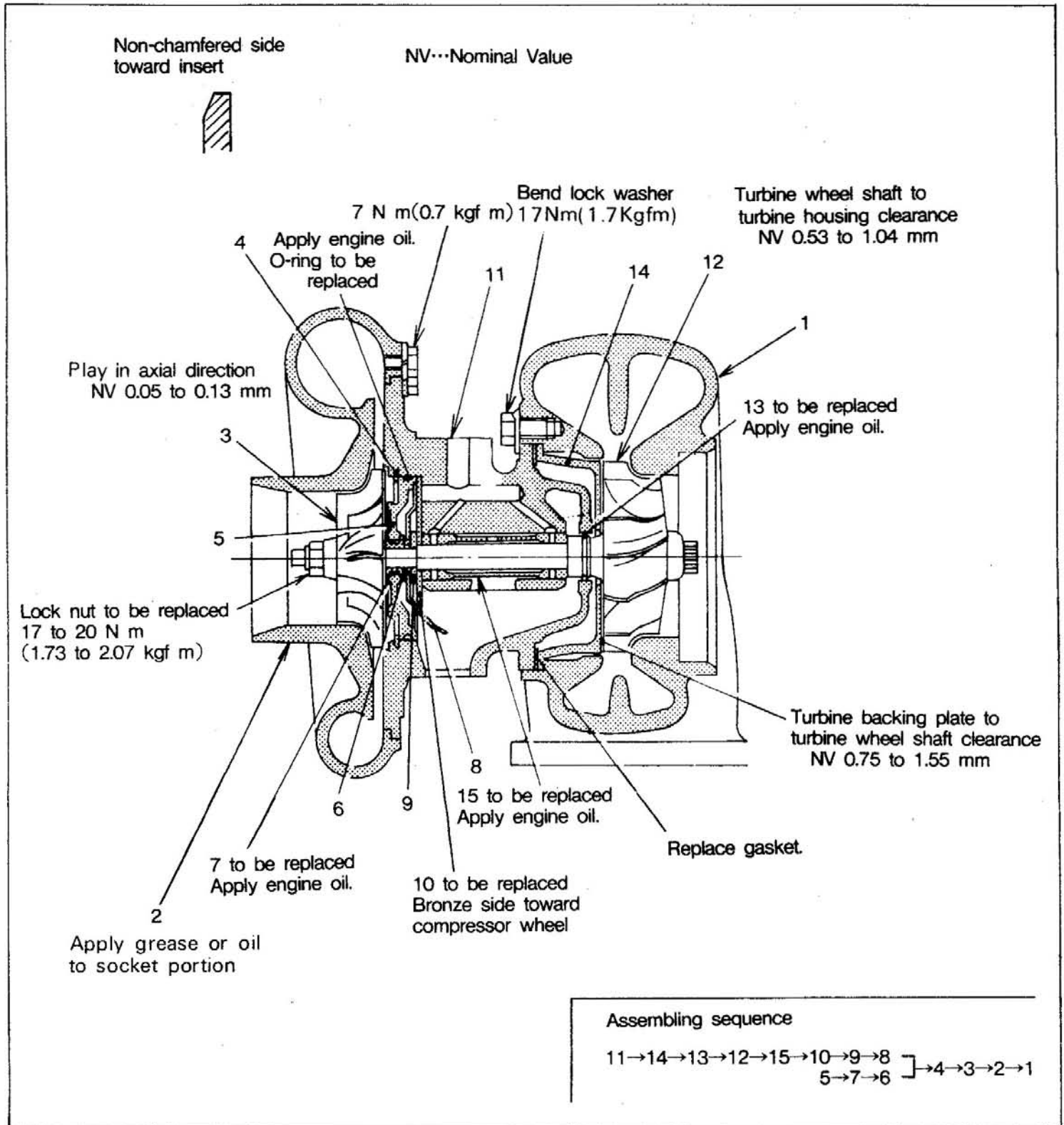

NOTE:After an overhauled turbo charger has been installed to the engine, run the engine at low idle speed for more than three minutes.

(1) Assemble the following parts.

11 Bearing housing

14 Turbine backing plate

13 Piston ring

12 Turbine wheel shaft

NOTE : Apply engine oil to the piston ring.

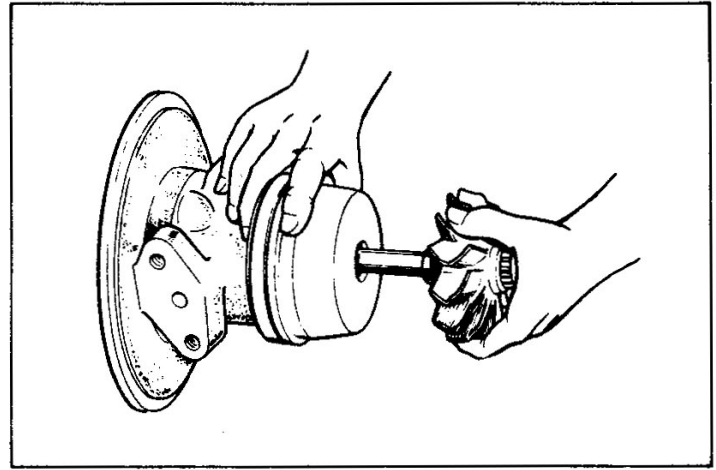

(2) Insert the core assembly into the turbine housing held in a vice.



(3) Apply engine oil to the I.D. and O.D. of the bearing 15 before installing the bearing in the bearing housing.

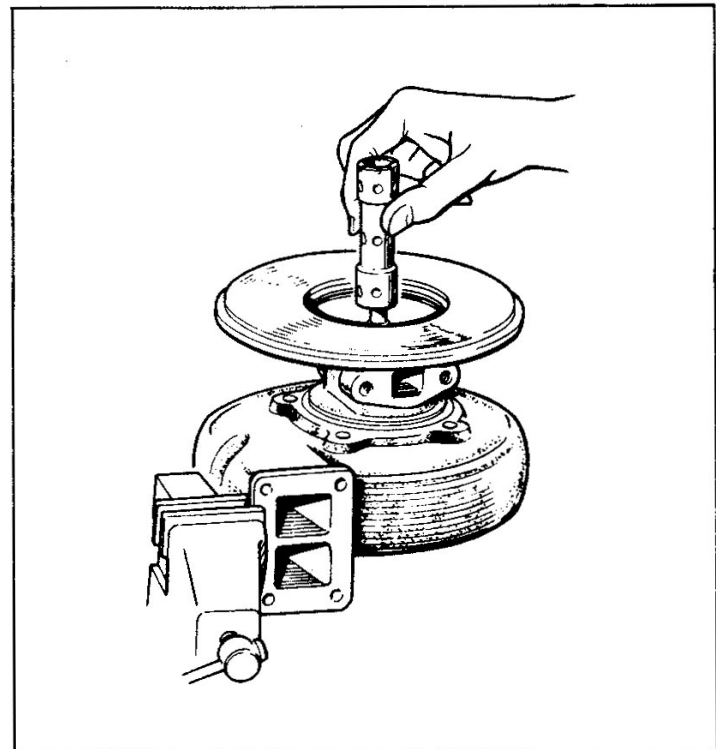

- (4) Apply engine oil to both sides of the thrust bearing 10 and thrust ring 9 before assembling them on the turbine wheel shaft. Then install the oil deflector 8.

NOTE : Install the thrust bearing with the bronze side up.

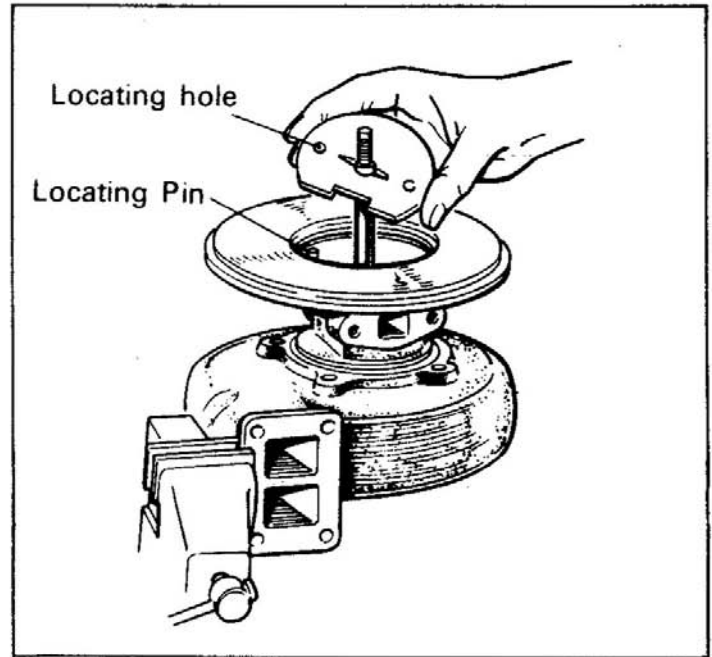

- (5) Assemble the following parts and install them in the bearing housing.

5 Insert

7 Piston ring

6 Thrust sleeve

NOTE : Apply engine oil to piston ring, flinger sleeve, O-ring and bearing housing before assembly.

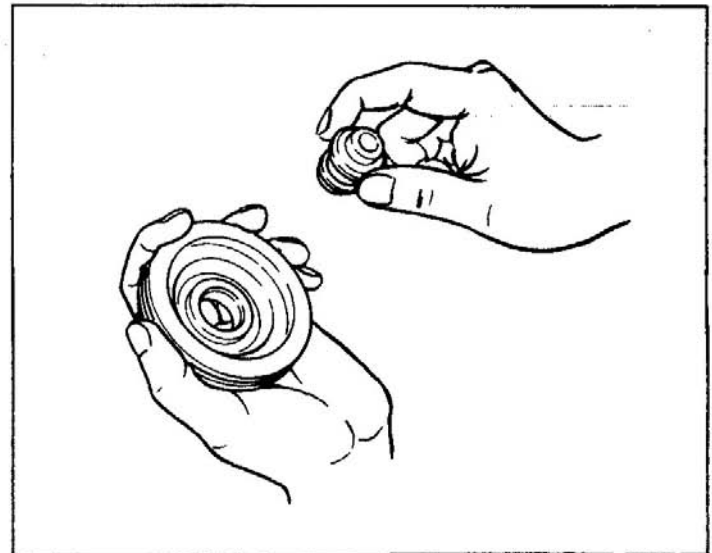

- (6) Install the snap ring 4.

NOTE : Face the non-chamfered side toward the insert.

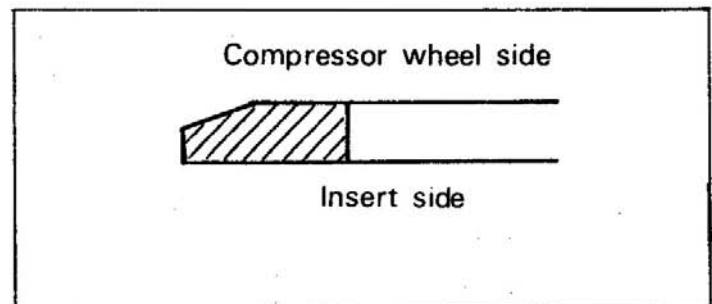

- (7) Set a dial indicator on the end of the turbine wheel shaft.

Move the turbine wheel shaft up and down to measure the clearance between the turbine wheel and turbine housing. If the clearance is out of specification, disassemble and check to locate the cause.

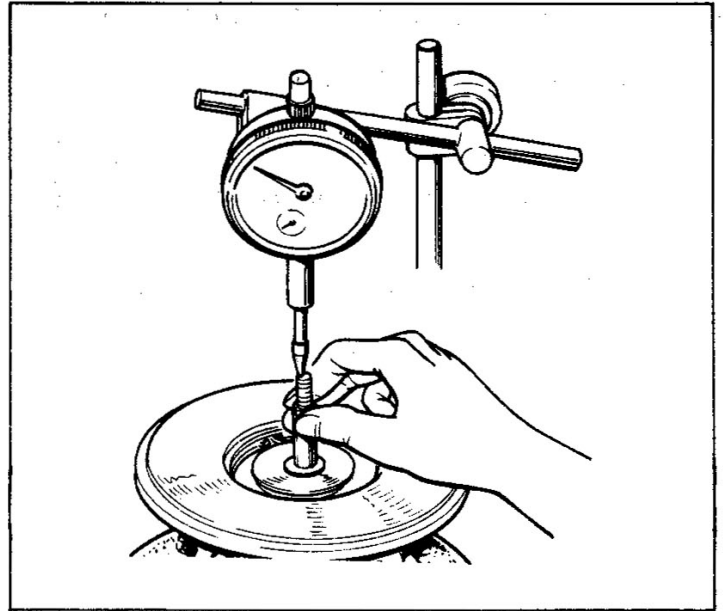

- (8) Install the compressor wheel 3 on the turbine wheel shaft and tighten the lock nut to the specified torque.

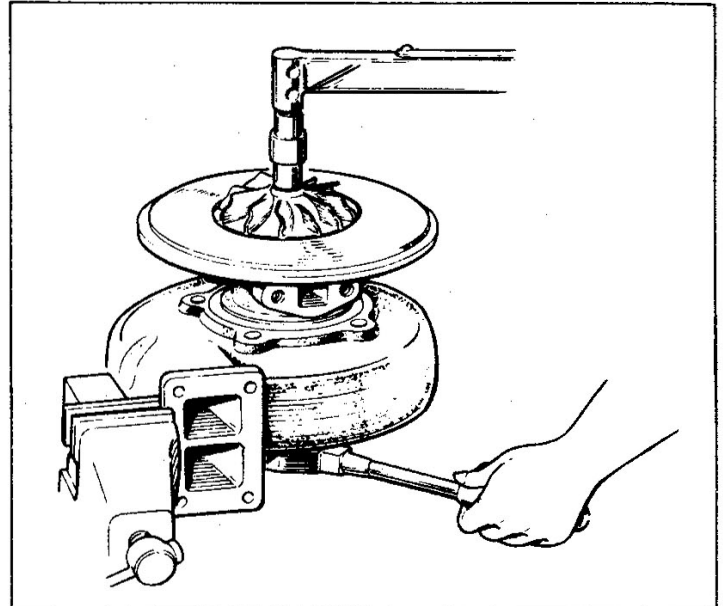

- (9) Set a dial indicator on the turbine wheel shaft end. Move the compressor wheel up and down to measure the end play.
- If the play is out of specification, disassemble and check to locate the cause.

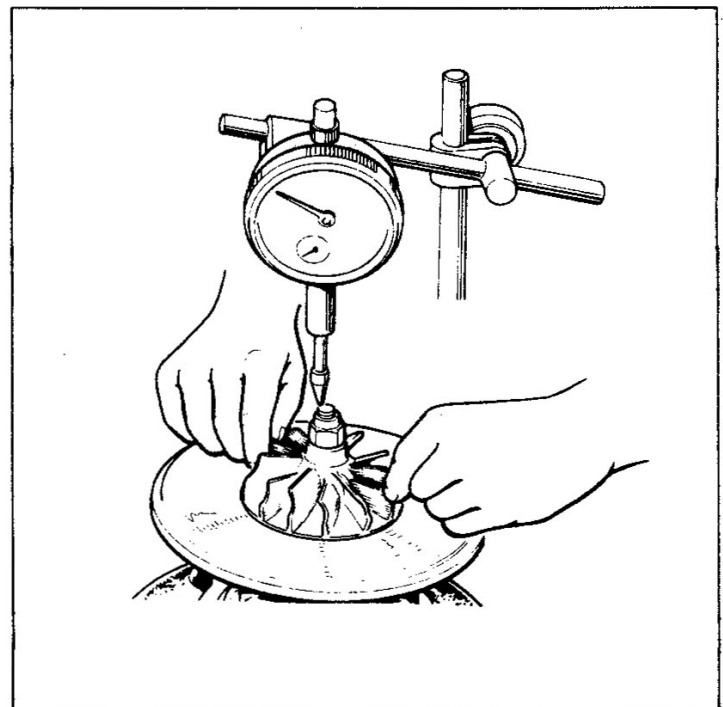

- (10) Apply grease or engine oil to the socket portion of the compressor cover.

Remove the core assembly from the turbine housing and insert into the compressor cover.

Using two thickness gauges, measure the clearance between the turbine backing plate and turbine wheel shaft back surface.

If the clearance is out of specification, disassemble and check to locate the cause.

- (11) Install the compressor cover 2 by tightening the bolts to the specified torque.

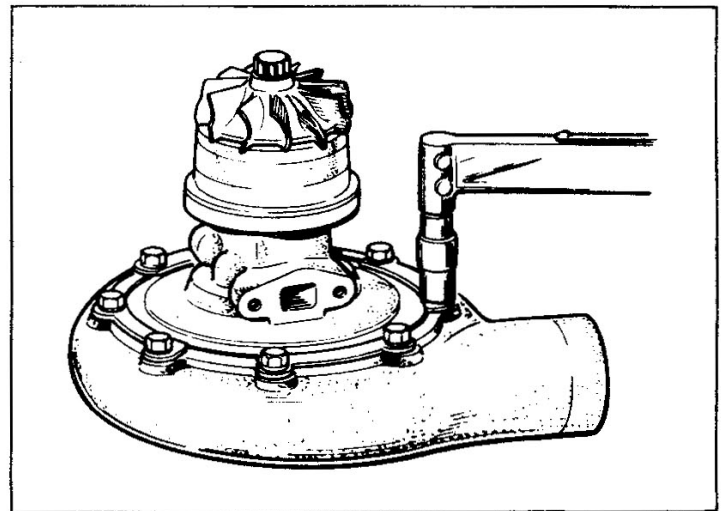

- (12) Install the turbine housing 1 by tightening the bolts to the specified torque.

NOTE : Apply an anti-seizure agent to the cap screw.

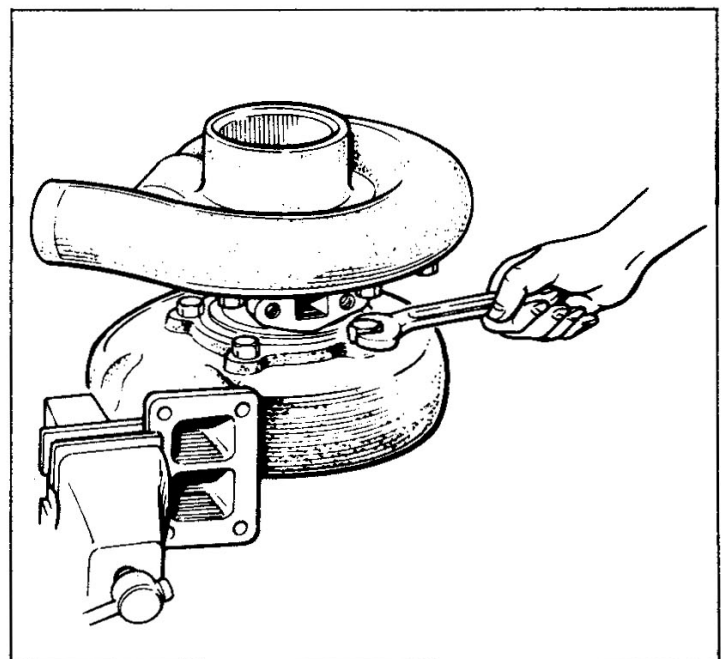

In servicing the lubrication system, use the following tools.

General tools and measuring devices

Micrometer for external measurement

Micrometer for internal measurement

Straight edge

Thickness gauge

9-1 OIL PUMP

9-1-1 Disassembly and Inspection

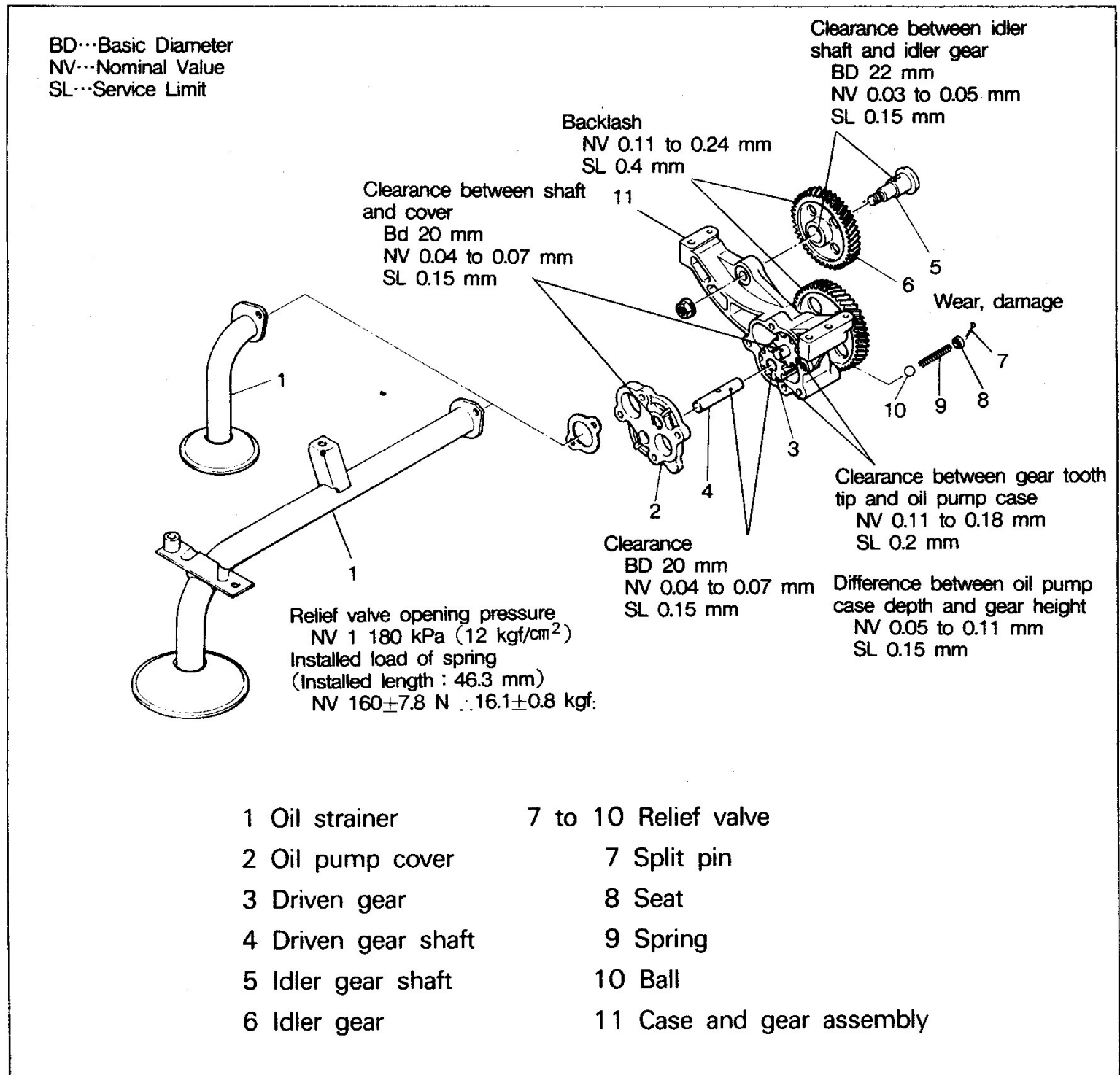

When disassembling the oil pump, pay attention to the following items.

- (1) Prior to disassembly, measure and record the backlash between the oil pump gear and idler gear.
- (2) Remove the oil strainer 1. Remove the oil pump cover 2 by lightly striking with a plastic hammer, etc.

NOTE : The oil pump cover is positioned by the dowel pin in the oil pump case.

- (3) Before the drive gear and driven gear are removed, measure and record the following items.

- (a) Measure the difference between the drive and driven gear height and the oil pump case depth with a thickness gauge.
- (b) Measure the clearance between the drive and driven gear tooth ends and the oil pump case with a thickness gauge.

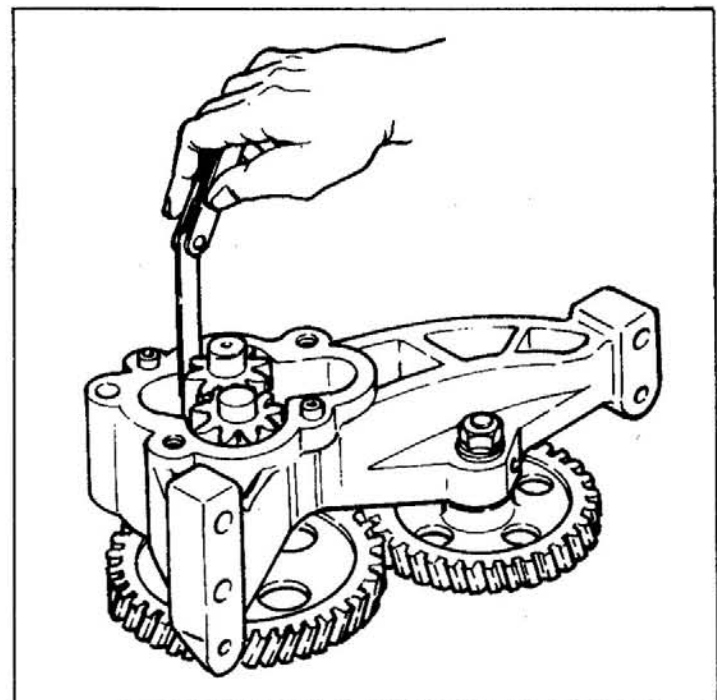
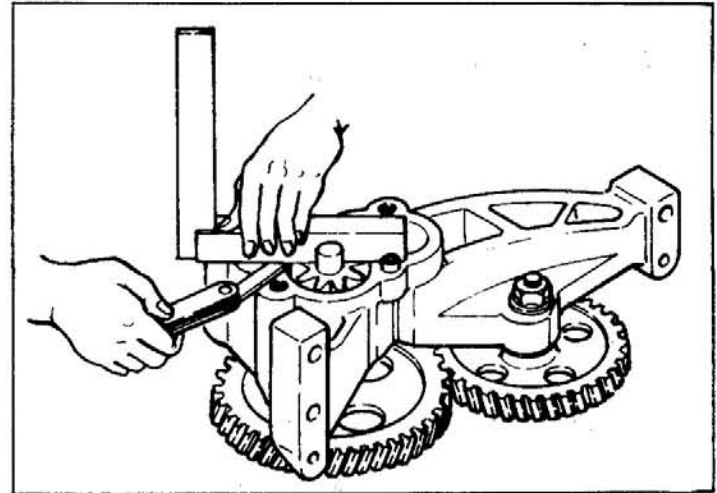
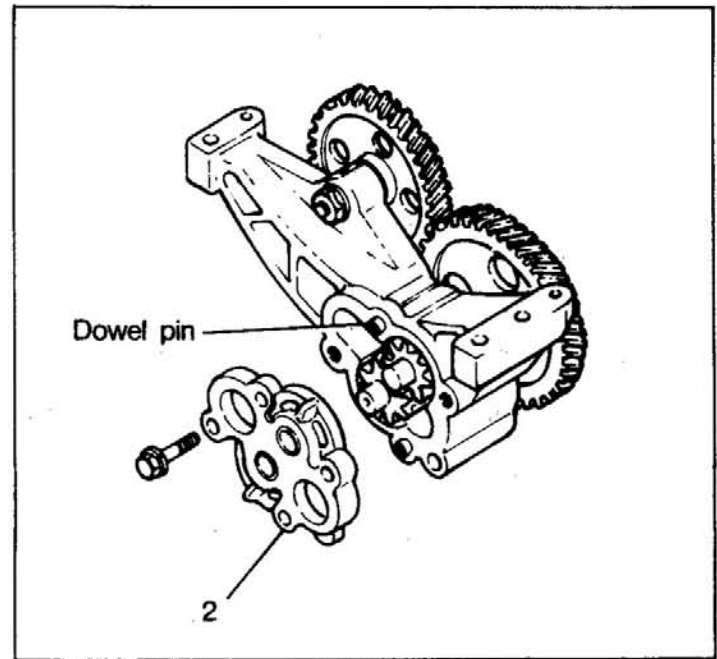

(4) Remove the following parts.

- 3 Drive gear
- 4 Driven gear shaft
- 5 Idler gear shaft
- 6 Idler gear

NOTE : Do not remove the driven gear shaft unless it is defective, as an insufficient interference with the oil pump case could otherwise result.

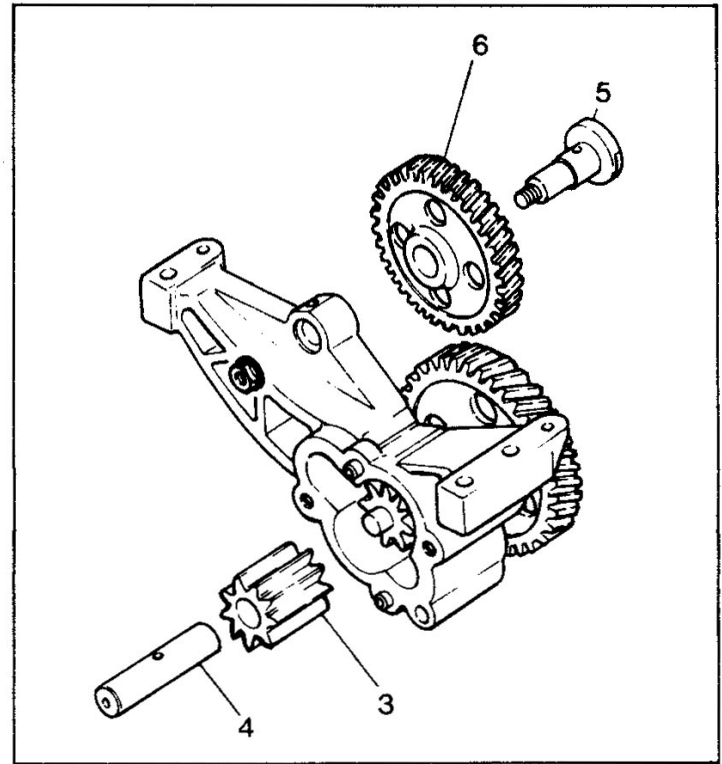

(5) Remove the following parts.

- 7 Split pin
- 8 Seat
- 9 Spring
- 10 Ball

NOTE : The case and gear assembly cannot be disassembled. If defective, replace as an assembly.



(6) Measure and record the outside diameters of the drive gear shaft, driven gear shaft and idler gear shaft. Then, measure and record the inside diameter of each bushing in the oil pump case, cover and driven gear. Calculate the clearances from the measured values, and the parts which have exceeded the service limits should be replaced.

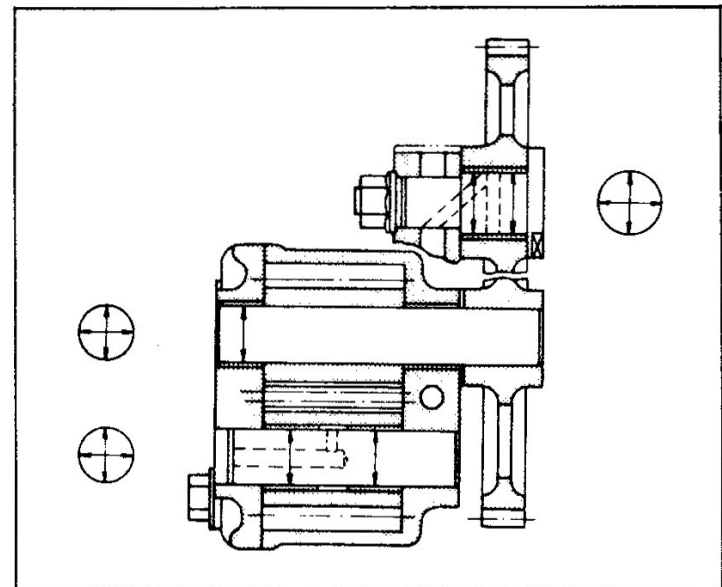

9-1-2 Reassembly

Prior to reassembly, apply engine oil to all parts unless otherwise specified.

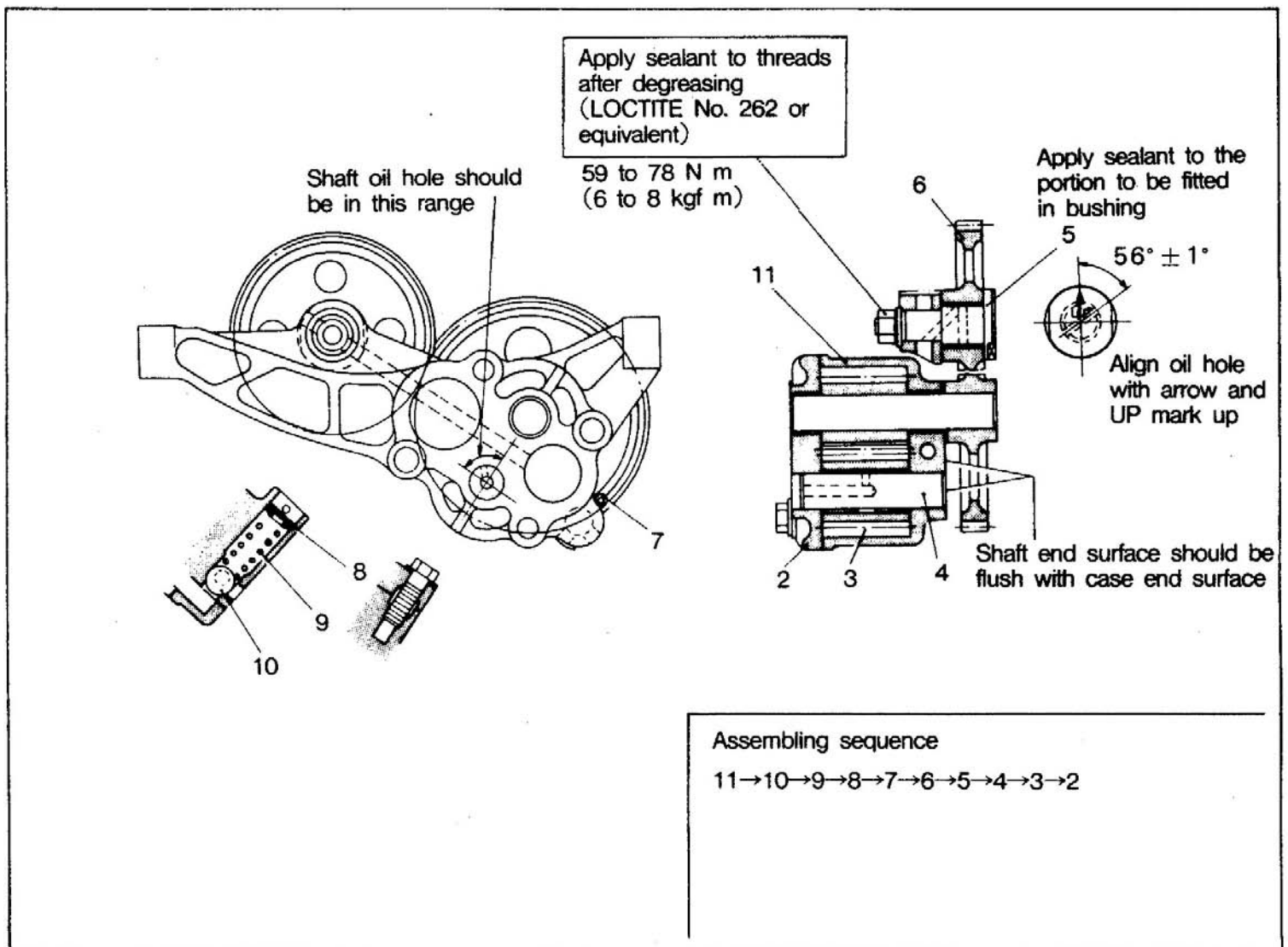

NOTE : Temporarily tighten the oil strainer 1 for installation in the crankcase.

9-2 OIL FILTER

NV...Nominal Value

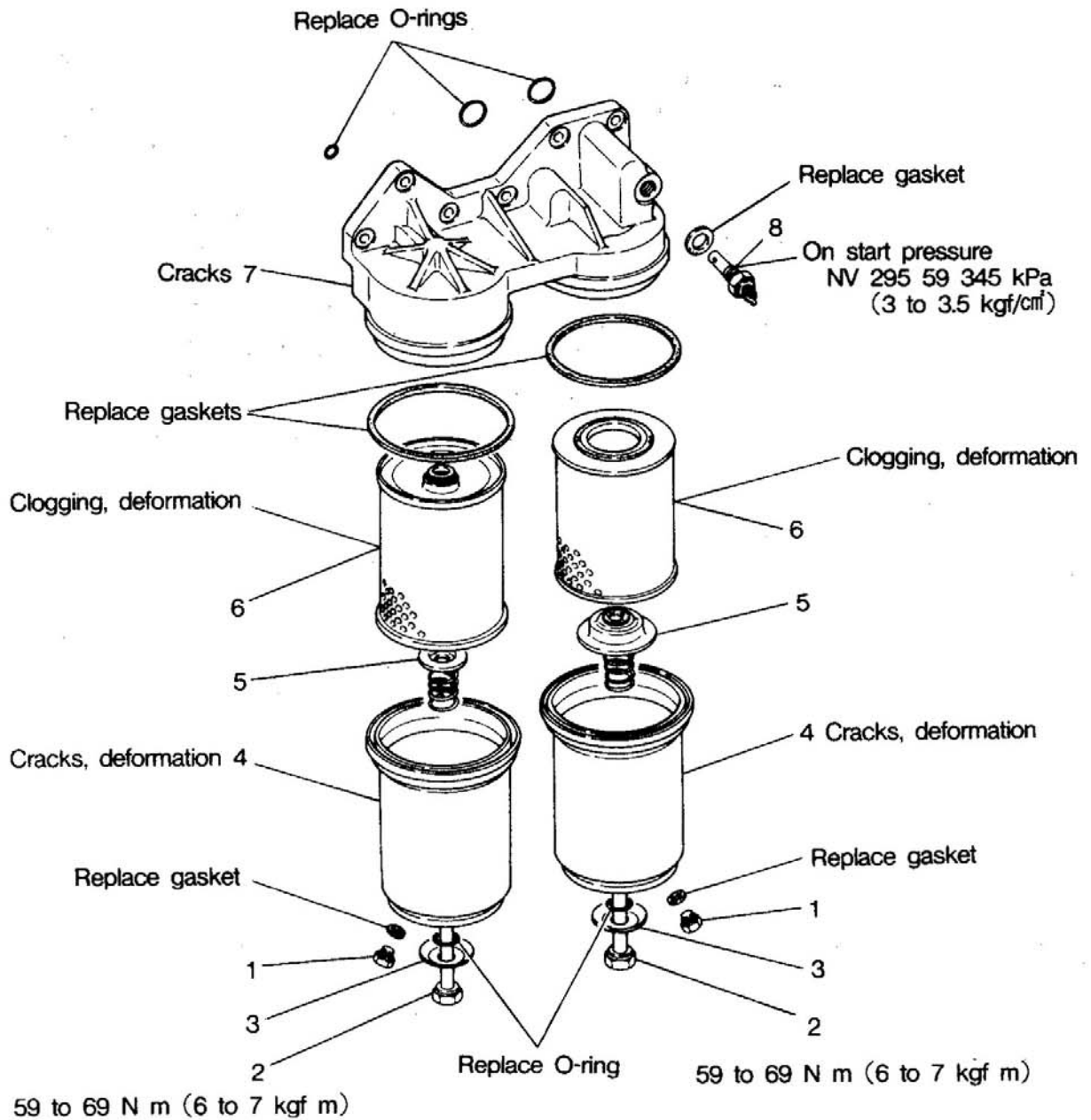

- | | |
|-------------------|----------------------|
| 1 Drain plug | 5 Spring retainer |
| 2 Center bolt | 6 Oil filter element |
| 3 Washer | 7 Oil filter head |
| 4 Oil filter case | 8 Oil bypass alarm |

9-3 OIL COOLER

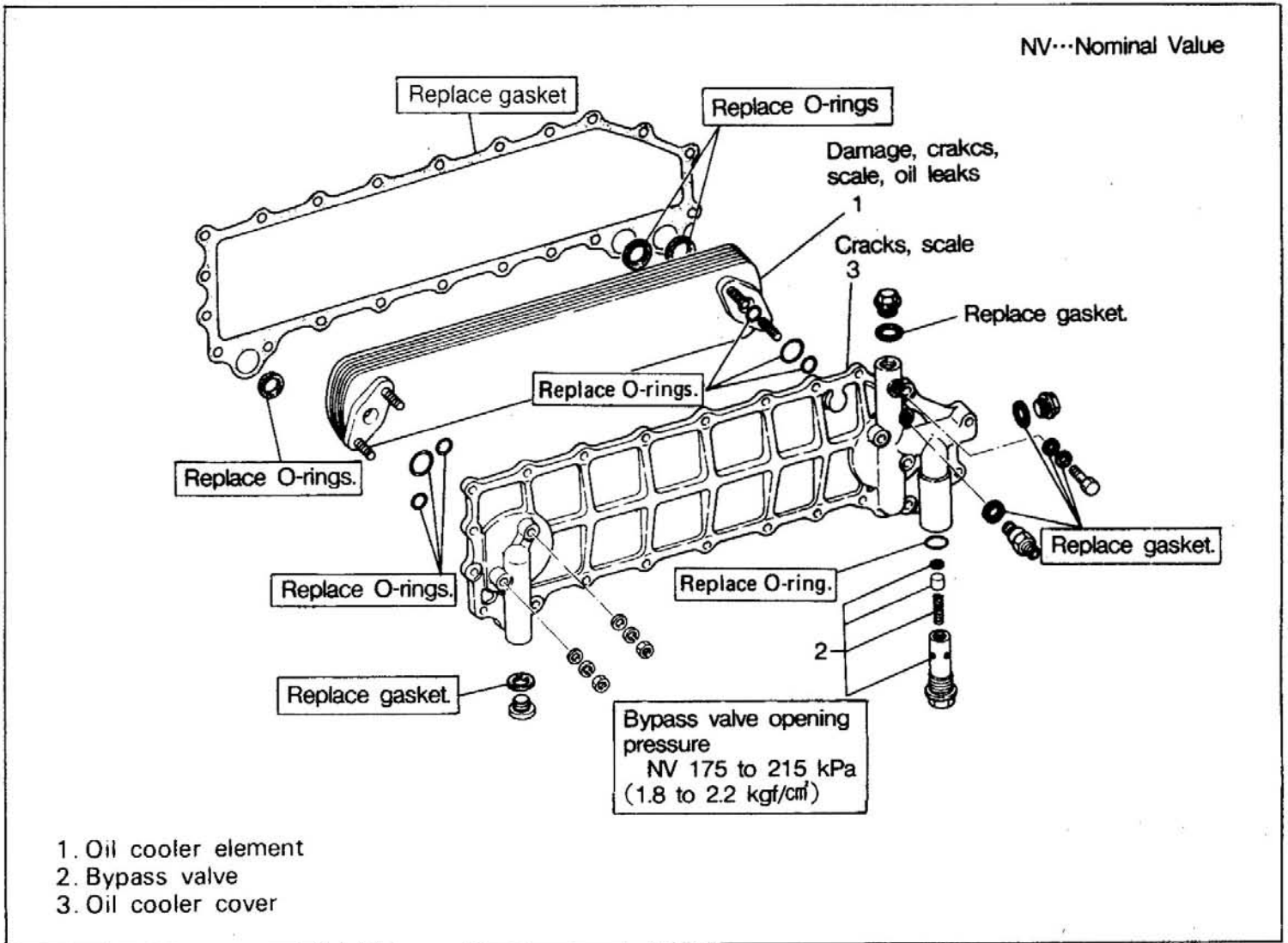

9-3-1 Cleaning

- (1) Check for carbon or sludge deposited in the oil passage of the oil cooler element and bypass valve. If contamination is evident, wash in a cleaning oil.
- (2) If there is much scale on the element and cover, wash in the cleaner Radipet 7 or caustic soda solution.

9-3-2 Air Pressure Test

To check for oil leaks due to a broken or cracked element, air pressure test should be performed.

Apply 980 kPa(10 kgf/m²) air pressure to the element to check for leaks.

If air leaks or other defects are evident, replace the element.

NOTE : Make sure that the specified air pressure is not exceeded.

9-4 REGULATOR VALVE

- 1 Snap ring
- 2 Valve
- 3 Spring
- 4 Body

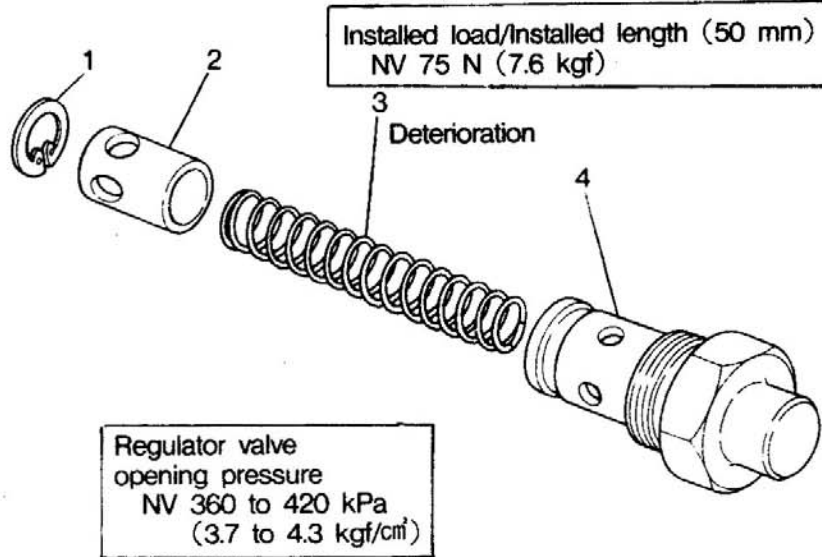

NV...Nominal value

9-5 CHECK VALVE

- 1 Check valve
- 2 Oil jet body

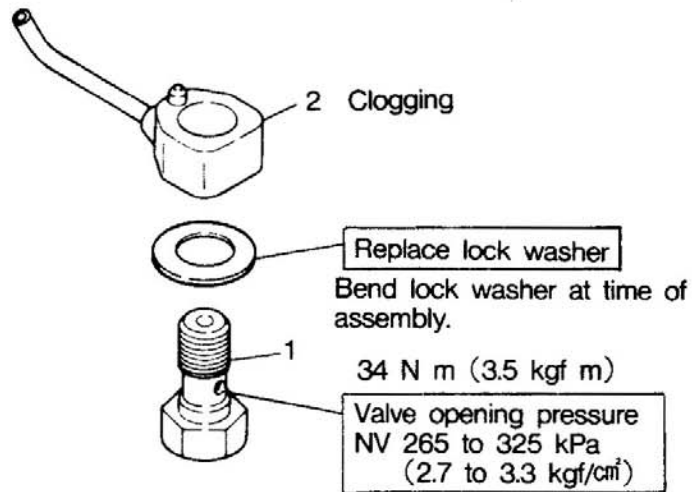

NV...Nominal value

For servicing the cooling system, use the following tools.

Special tool name	Part No.	Use
Water pump impeller puller	MH061417	For removal of water pump impeller

10-1 WATER PUMP

10-1-1 Disassembly and Inspection

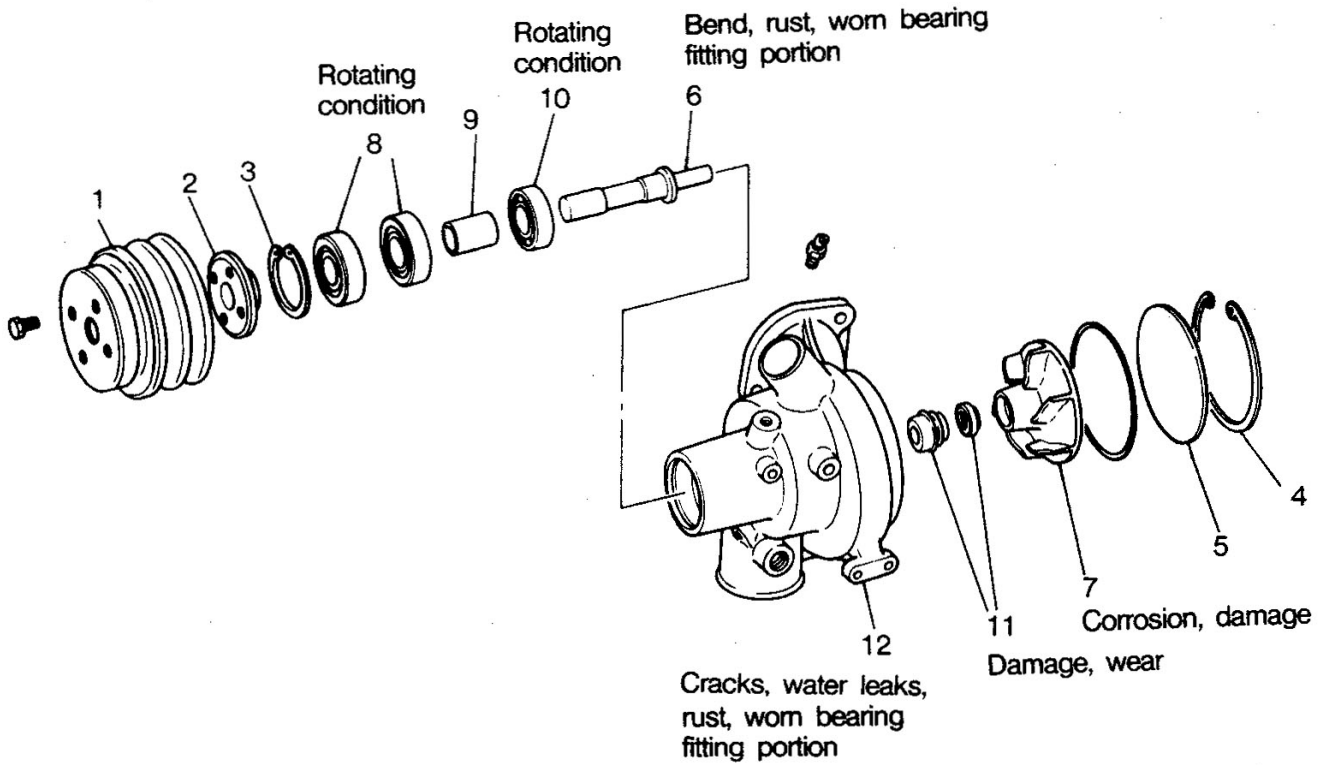

- | | |
|---------------------|--------------------|
| 1 Water pump pulley | 7 Impeller |
| 2 Flange | 8 Ball bearing |
| 3 Snap ring | 9 Spacer |
| 4 Snap ring | 10 Ball bearing |
| 5 Cover | 11 Unit seal |
| 6 Water pump shaft | 12 Water pump case |

- (1) Remove the water pump pulley 1. Pull off the flange 2 with Gear Puller etc. and remove the snap ring 3.

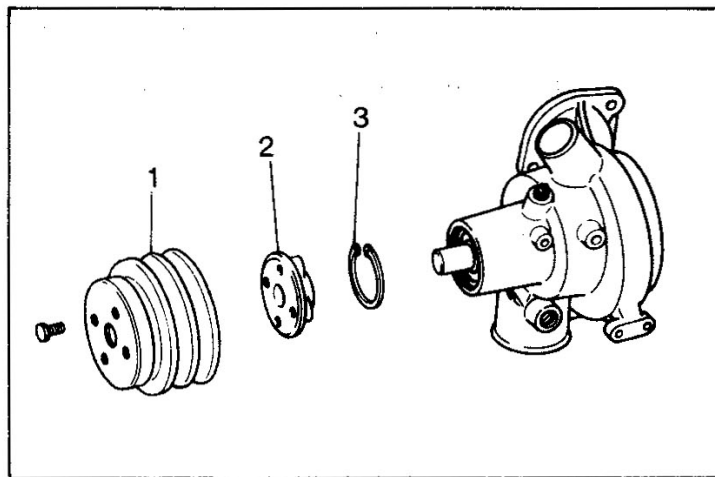

- (2) Remove the snap ring 4 and remove the cover 5.

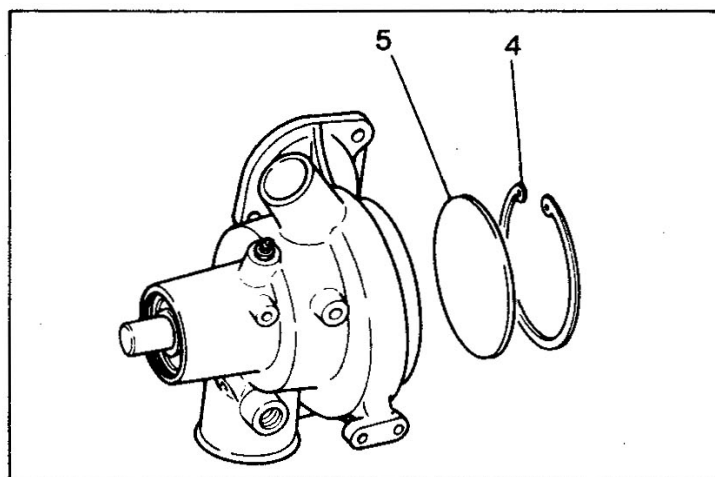

- (3) Using two threaded holes (M8×1.25) in the impeller 7 and the Puller (special tool), pull off the impeller 7 and remove the water pump shaft 6.

Check the unit seals in the impeller and water pump case for wear and damage and replace the unit seal 11 if defective or water leaks during operation.

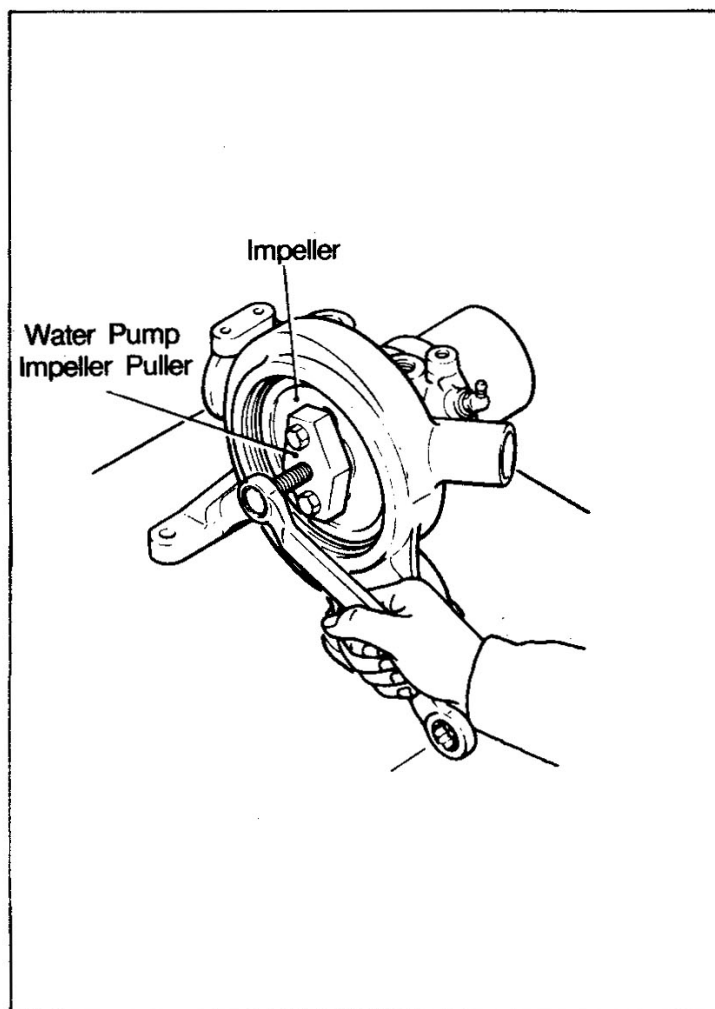

(4) Remove the ball bearings 8 and 10 from the water pump shaft with a gear puller etc.

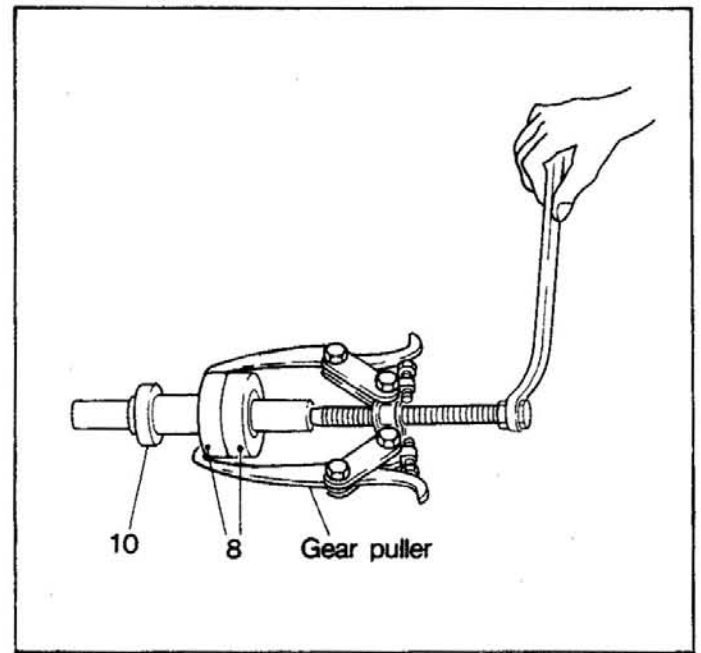

10-1-2 Reassembly

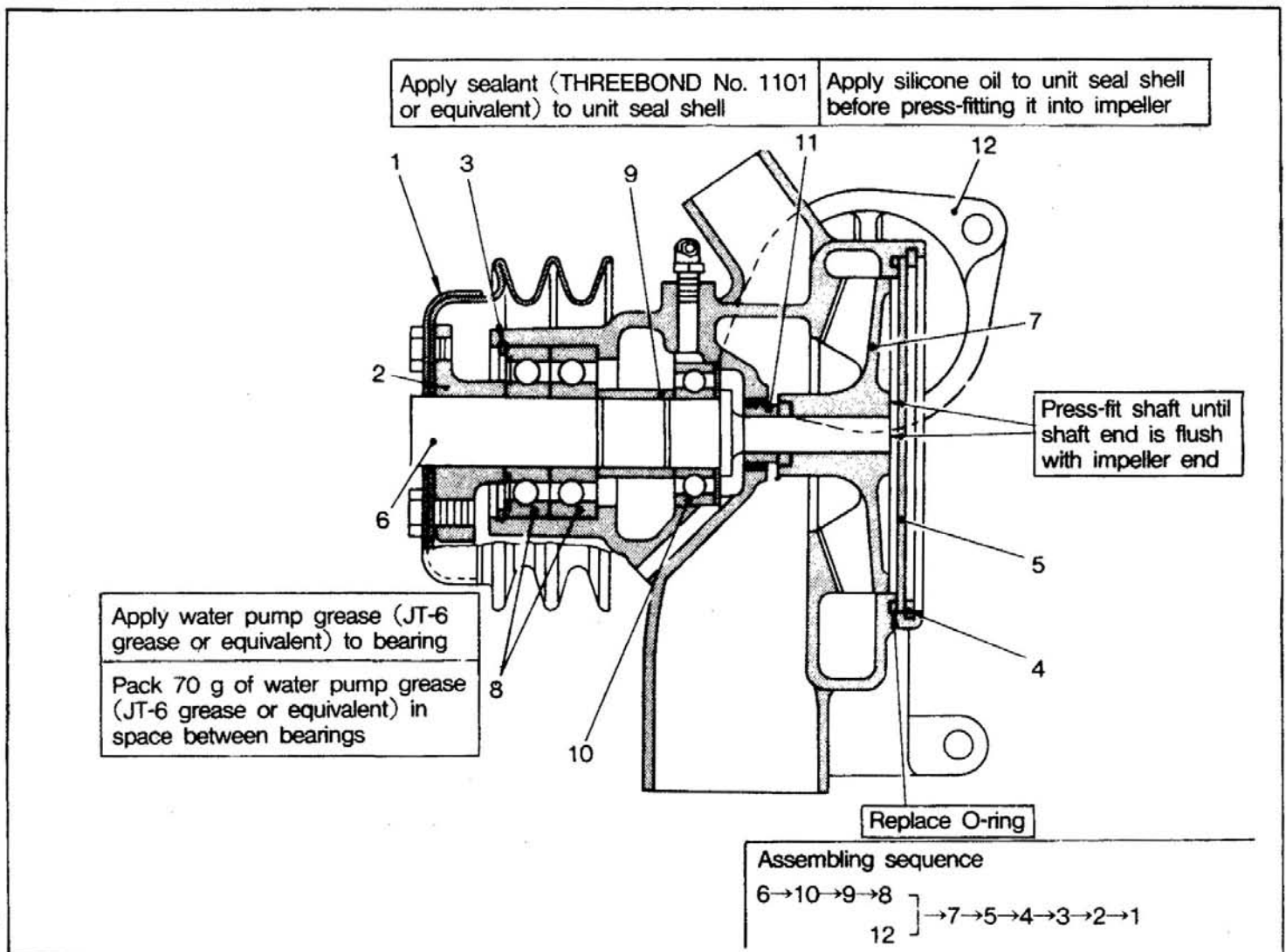

NOTE : After reassembly, turn the water pump pulley by hand to confirm that the impeller does not touch the case and cover.

10-2 THERMOSTAT

10-2-1 Inspection of Thermostat

Check the thermostat by the following procedures. Stir the water in the container with a rod equalize water temperature.

- (1) Slowly heat the thermostat to the valve opening temperature.

Keep this condition for about five minutes and check to ensure that the valve is open.

- (2) Raise the water temperature further to 95°C.

Keep this condition for five minutes and measure the lift of the pellet.

- (3) Lower the temperature to less than 65°C and check to see that the valve is held tightly against the valve seat.

Check all of the above items. If any of the items fails, replace the thermostat

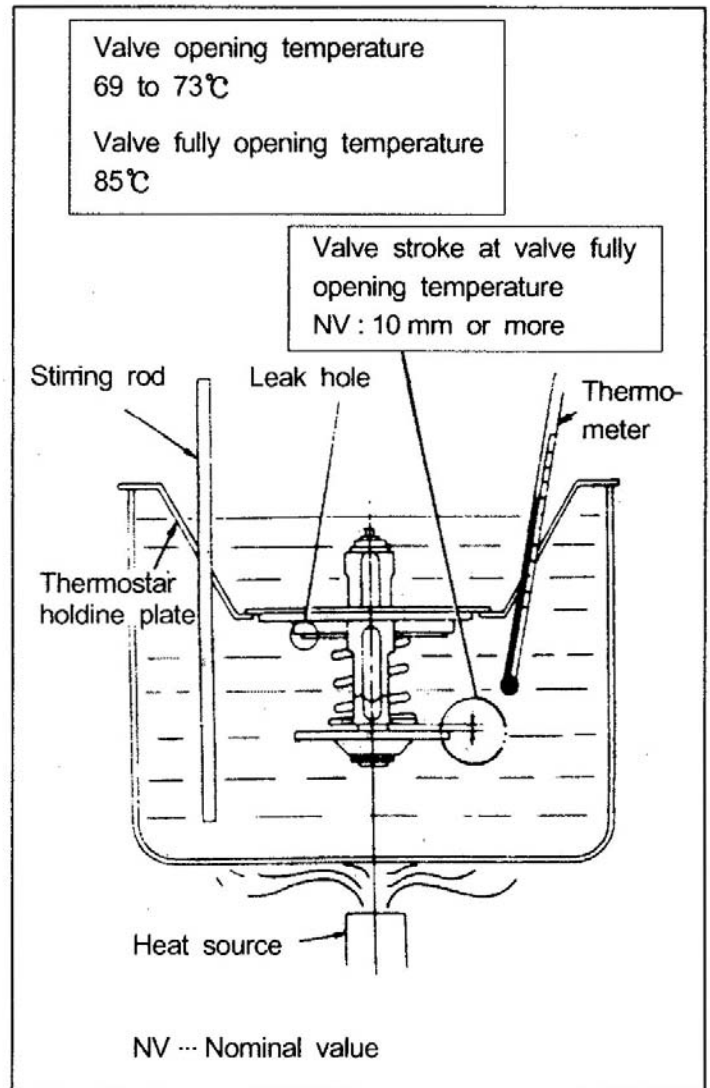

NOTE : The two thermostats in normal control trucks differ in valve opening temperature. The valve opening temperature is stamped on the thermostat.

10-3 FAN DRIVE AND TENSION PULLEY

10-3-1 Disassembly and Inspection

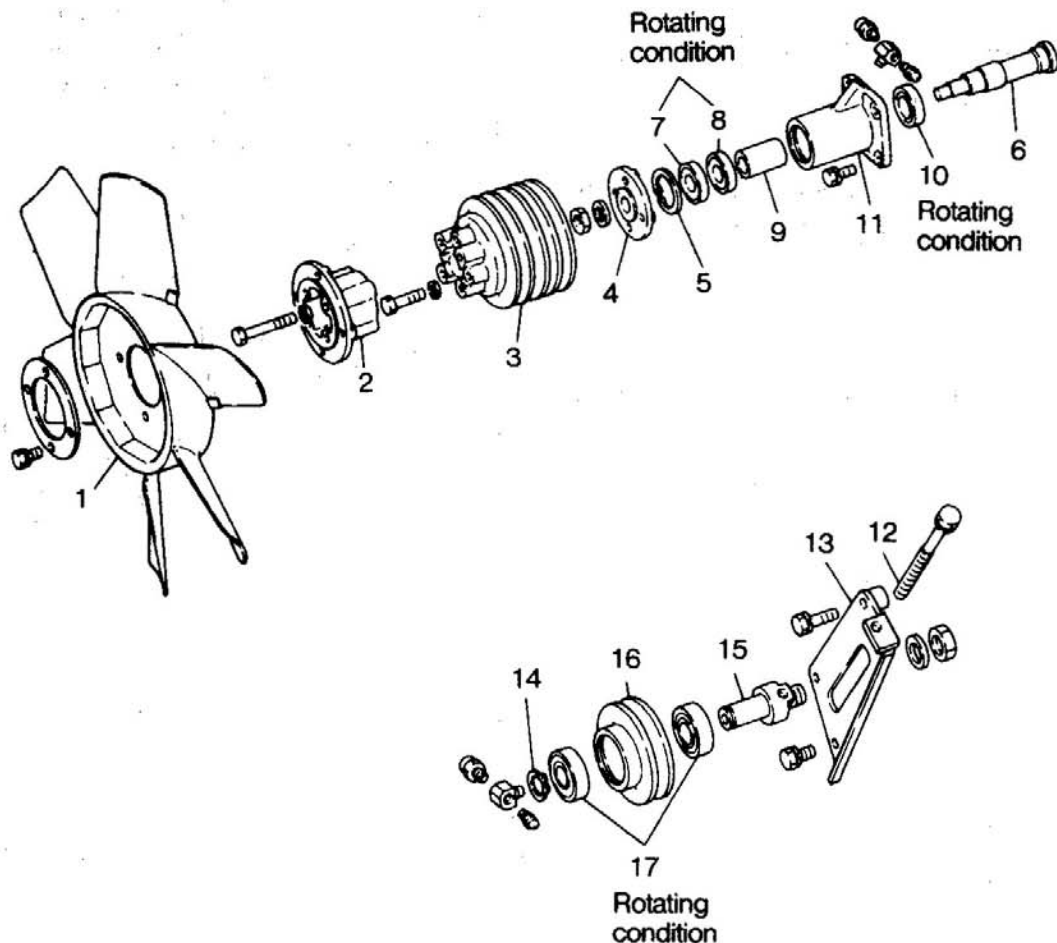

- | | |
|-------------------------------|---------------------------|
| 1 Fan | 10 Ball bearing |
| 2 Spacer | 11 Bearing case |
| 3 Fan pulley | 12 Adjusting bolt |
| 4 Coupling flange | 13 Tension pulley bracket |
| 5 Snap ring | 14 Snap ring |
| 6 Fan drive shaft | 15 Tension pulley shaft |
| 7 Ball bearing(one-side seal) | 16 Tension pulley |
| 8 Ball bearing | 17 Ball bearing |
| 9 Spacer | |

10-3-2 Reassembly

Face the shield surface outward.
Apply grease (JT-6 grease or equivalent).

Apply grease (JT-6 grease or equivalent) every 125 hours.

Pack 6g of grease (JT-6 grease or equivalent).

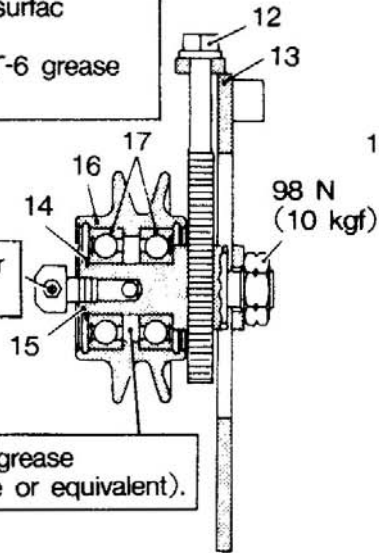

10 to 15 mm 10 to 15 mm

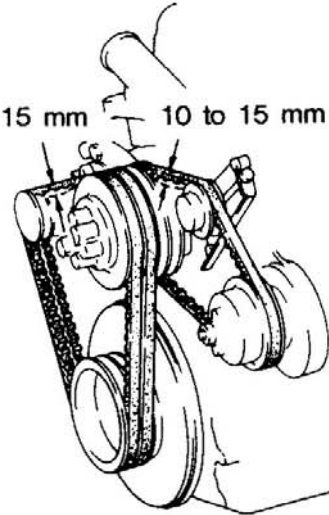

Face seal surface outward.
Apply grease (JT-grease or equivalent).

Apply grease (JT-6 grease or equivalent) every 125 hours.

145 N m (15 kgf m)

Pack 86g of grease (JT-6 grease or equivalent).

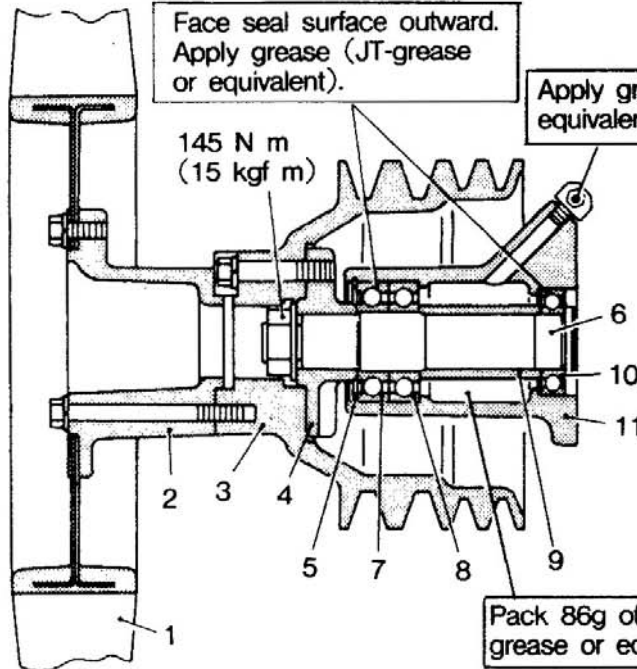

Prior to disassembly, test the parts of the fuel system to precisely grasp their conditions unless it is impossible to make their test.

Make sure that the parts of the fuel system are disassembled and reassembled in a clean place, as small particles of dust deposited in the parts can produce large effects on engine performance.

In servicing the fuel system, use the following tools.

(1) AD Type Injection Pump Proper

The part numbers are the ZEXEL part numbers.

Special Tool Name	Part No.	Use
AD type injection pump special tool set	105790-1060	Disassembly and reassembly
Universal vice	105794-0090	Mounting base
Tappet pin	157931-3120	Supporting of tappet
Measuring device	105782-4130	Measurement of camshaft end play
Wrench	157910-1120	Removal and installation of screw
Guide	157920-5400	Protection of oil seal
Roller pincers	157921-3020	Removal and installation of tappet
Tappet pincers	157931-7120	
Plunger pincers	157921-6120	Removal and installation of plunger
Wrench	157914-0500	Removal and installation of delivery valve holder
Extractor	157925-6520	Removal of inner race
	157925-0520	Removal of outer race(timer side)
	157925-0120	Removal of outer race(governor side)
Reamer	157930-4620	Correction of pump housing

(2) P Type Injection Pump Proper

The part numbers are the ZEXEL part numbers.

Special Tool Name	Part No.	Use
P type injection pump special tool	105790-7000	Disassembly and reassembly
Universal vice	105794-0010	Mounting base
Fitting plate	157944-3620	Installation
plate	157944-3820	
Tappet holder	157931-4700	Supporting of tappet
Bracket	157920-5600	Removal of bearing cover
Extractor bearing cover	157920-7720	
Tappet mounting device	157921-8020	Removal and installation of tappet
Plunger insert	157921-4820	Removal and installation of plunger
Plunger clamp device	157921-5620	Removal and installation of control sleeve
Extractor	105792-0030	Removal of plunger block assembly
Fitting plate	157944-3520	Disassembly and reassembly of plunger block assembly
Socket wrench	157914-0500	Removal and installation of delivery holder
Special wrench	157915-6500	Removal and installation of screw bushing
Inner race extractor	157925-7120	Removal of inner race
Outer race extractor	157925-2020	Removal of outer race
O-ring insert	105792-0000	Installation of O-ring
Plate measuring	157828-7200	Positioning of governor side taper roller bearing
Camshaft measuring device	105782-4140	Measurement of camshaft end play

(3) RSV Type Governor

The part numbers are the ZEXEL part numbers.

Special Tool Name	Part No.	Use
Handle	157910-0300	Removal and installation of lock nut
Socket wrench	157914-0500	
Wrench	157915-0100	Removal and installation of round nut
Extractor	157926-5110	Removal and installation of flyweight

(4) RFD Type Governor

The part numbers are the ZEXEL part numbers.

Special Tool Name	Part No.	Use
Socket wrench	157914-0500	Removal and installation of lock nut
Special wrench	157915-0100	Removal and installation of round nut
Extractor	157926-5320	Removal of flyweight

(5) SA Type Automatic Timer

The part numbers are the ZEXEL part numbers.

Special Tool Name	Part No.	Use
SA type automatic timer special tool set	105790-5010	Disassembly and reassembly
Special spanner	157916-5320	Removal and installation of round nut
Extractor	157926-6210	Removal
Guide bolt	157924-0200	Disassembly and reassembly
Base	157924-0110	
Hand spanner	157916-6120	Removal and installation of timer case
Thrust bushing	157924-1500	Installation of oil seal
Guide bushing	157924-1200	
Block	157924-0800	
Guide bushing	157924-1300	
Guide	157924-0900	
Support	157932-0100	Installation of flyweight
Guide	157924-0400	
Thrust bushing	157924-0500	Installation of flange
Oil seal guide	157914-0600	Insertion of timer case

(6) SP Type Automatic Timer

The part numbers are the ZEXEL part numbers.

Special Tool Name	Part No.	Use
SP type automatic timer special tool set	105790-5050	Disassembly and reassembly
Box spanner	157915-2320	Removal and installation of round nut
Box wrench	157916-2800	
Special spanner	157916-5320	Removal and installation
Extractor	157926-6420	
Base	157924-2520	Disassembly and reassembly
Special spanner	157916-8320	

(7) AD Type Injection Pump Testing and Adjustment Tools

The part numbers are the ZEXEL part numbers.

Special Tool Name	Part No.	Use
Measuring device	105782-6010	Adjustment of control rack position
	105782-4020	Adjustment of prestroke

(8) P Type Injection Pump Testing and Adjustment Tools

The part numbers are the ZEXEL part numbers.

Special Tool Name	Part No.	Use
Fixing stand	105781-0170	Fixing of injection pump
Measuring device	105782-4210	Adjustment of control rod position
	105782-4190	Adjustment of prestroke

(9) Injection Nozzle

The part numbers are the DOOWON part numbers.

Special Tool Name	Part No.	Use
Nozzle cleaning tool	105789-0010	Cleaning of nozzle
Nozzle tester	105785-1010	Adjustment and testing

(10) Miscellaneous

The part numbers are the ZEXEL part numbers.

Special Tool Name	Part No.	Use
Filter wrench	MH061507	Removal of fuel filter element
Nonslip paper	MH061508	

11-1 INJECTION PUMP-GENERAL

11-1-1 AD Type Injection Pump

In servicing the injection pump, clean the work bench and arrange all disassembled parts neatly by cylinders. Use special care not to change combination of the plunger and plunger barrel and that of the delivery valve and delivery valve seat.

Disassemble and reassemble the major parts with utmost care.

For disassembly and reassembly, use the ZEXEL special tool set and be sure to avoid application of an undue force and rough operation.

Prior to disassembly, perform tests to grasp all defective points.

(1) Disassembly

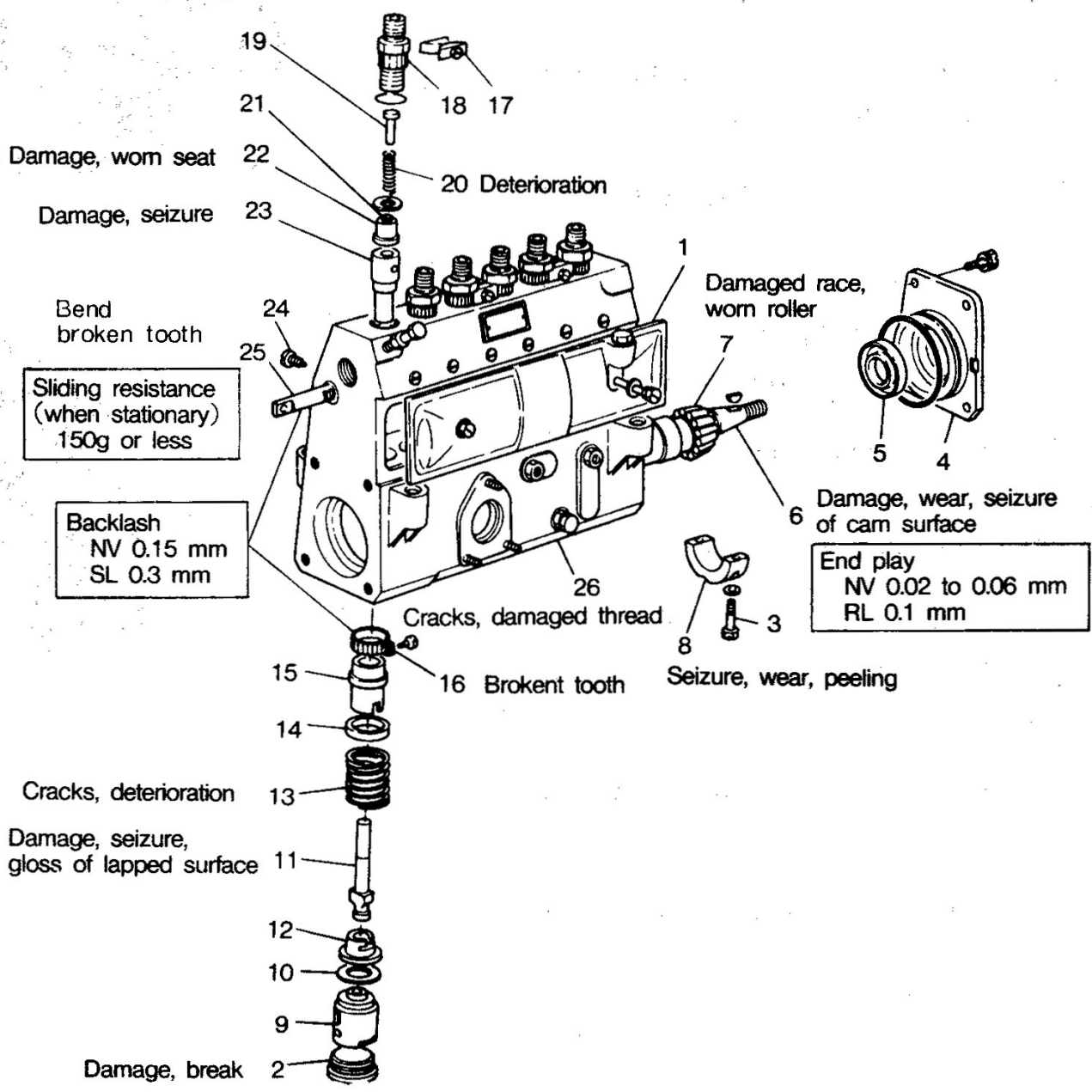

- | | | |
|------------------------|--------------------------|--------------------------|
| 1 Housing cover | 10 Shim | 19 Stopper |
| 2 Screw | 11 Plunger | 20 Delivery valve spring |
| 3 Screw | 12 Lower spring seat | 21 Delivery valve |
| 4 Bearing cover | 13 Plunger spring | 22 Delivery valve seat |
| 5 Oil seal | 14 Upper spring seat | 23 Plunger barrel |
| 6 Camshaft | 15 Control sleeve | 24 Screw |
| 7 Taper roller bearing | 16 Pinion | 25 Control rack |
| 8 Center bearing | 17 Lock plate | 26 Pump housing |
| 9 Tappet | 18 Delivery valve holder | |

- (a) Install the injection pump in a special tool (Universal Vice).
- (b) Remove the feed pump.
- (c) Remove the coupling and automatic timer. (Refer to Para. 11-1-6.)
- (d) Remove the governor. (Refer to Para 11-1-3.)

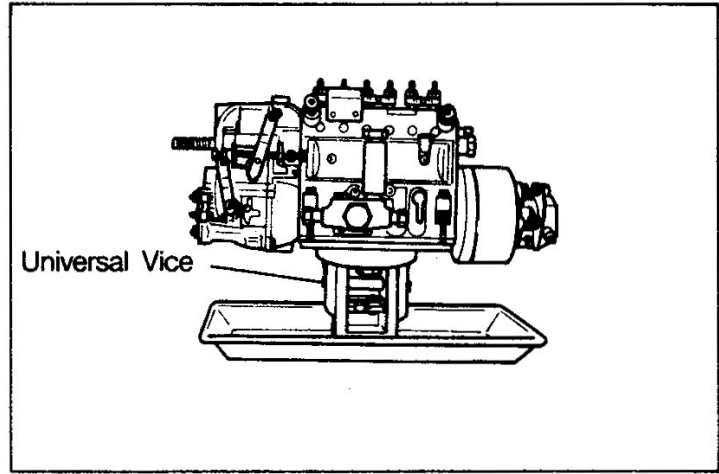

- (e) Measure the sliding resistance of the control rack with a spring balancer.

Turn the camshaft and measure the sliding resistance in all of the rising and falling positions of the cam.

If the readings are in excess of the nominal value, the following causes are probable.

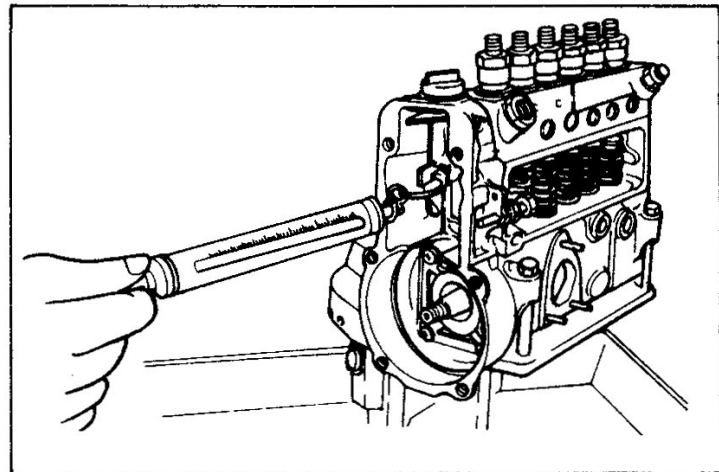

- 1) Damaged control rack, abnormal teeth.
- 2) Abnormal teeth of pinion, contact with housing
- 3) Overtightened delivery valve holder

- (f) Remove the housing cover 1.

Insert special tools (Tappet Pins) into the tappet holes of all the cylinders to space the tappets away from the camshaft.

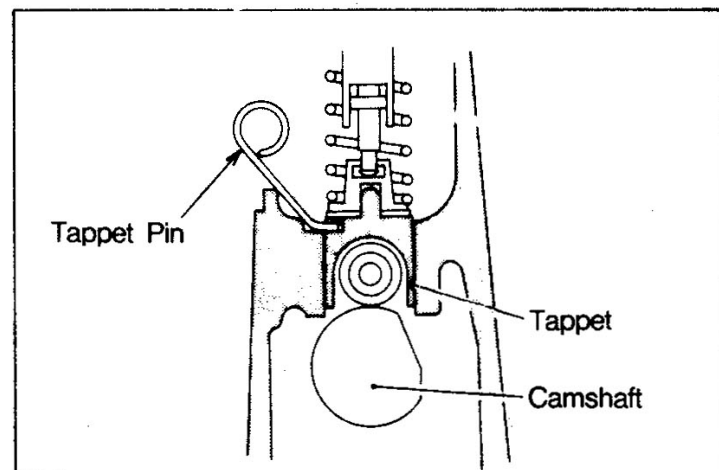

- (g) Measure the end play of the camshaft with special tool (Measuring Device). If the end play is in excess of the repair limit, adjust by using shims or replace the bearing.

Shim thickness	0.10, 0.12, 0.14, 0.16, 0.18, 0.30 0.50, 1.00mm
----------------	---

NOTE : Select timer and governor side shims so that their thicknesses will be about equal.

- (h) Remove the screws 2 at the bottom of the injection pump with special tool (Wrench).

- (i) Insert a screwdriver into the groove in the bearing cover to remove the bearing cover 4 and oil seal 5.

NOTE : 1. To prevent damaging the oil seal, remove the woodruff key from the camshaft and put special tool (Guide) on the threaded portion.

2. To remove the camshaft, direct the first cam lobe on the removal side of camshaft toward the top of the pump to prevent the camshaft lobe from touching the tappets, and then lightly strike.

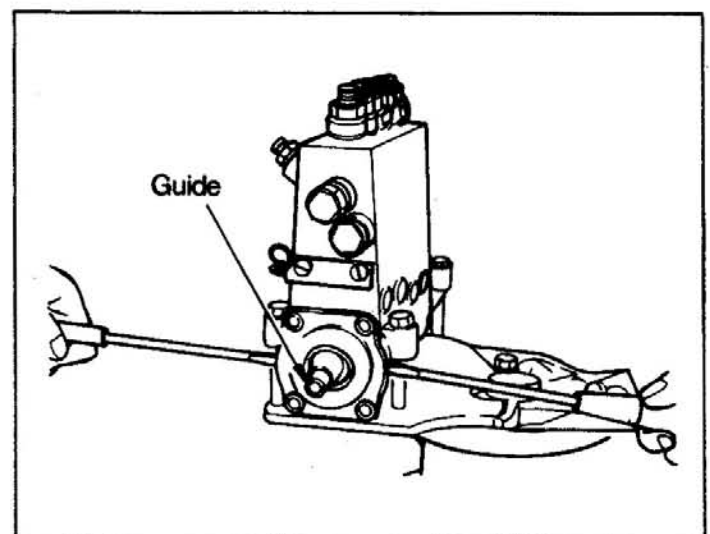
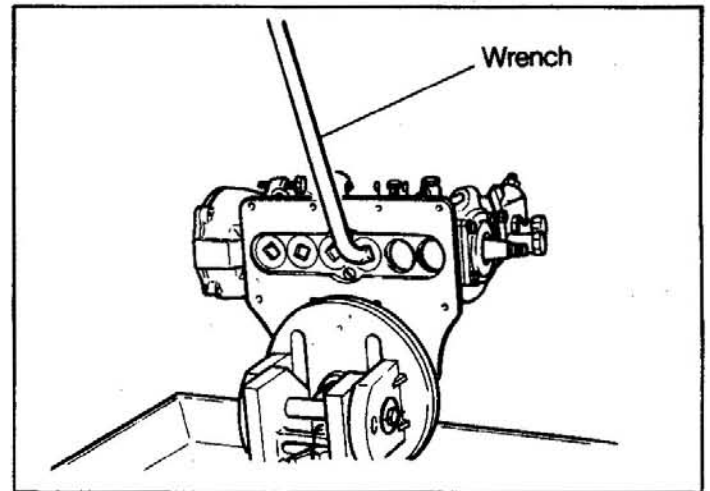
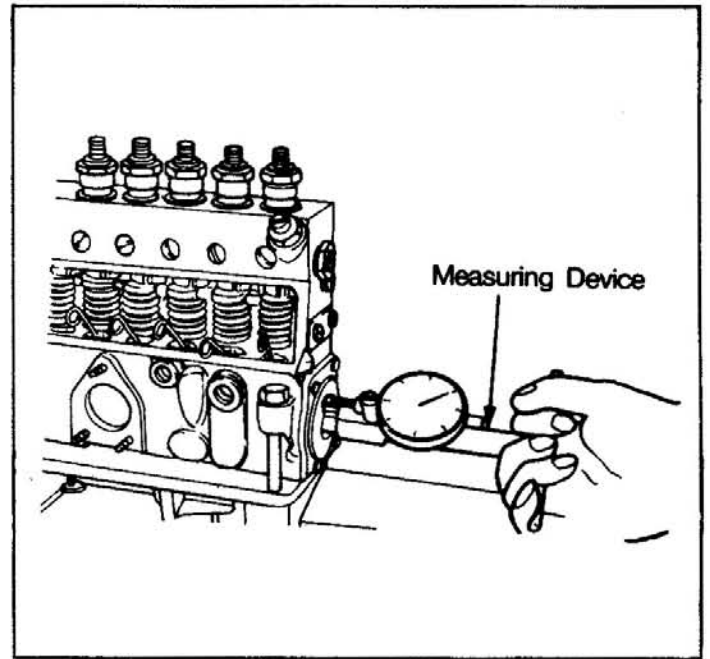

- (j) Push the tappets up from the bottom of the injection pump with special tool (Roller Pincers) and remove the special tools (Tappet Pins).

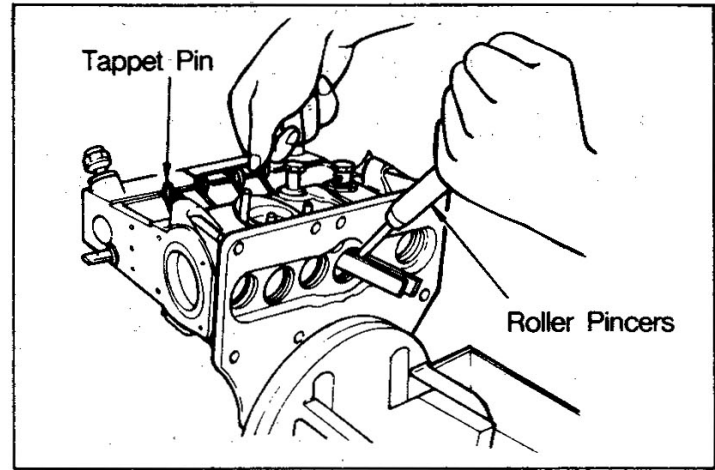

- (k) Hold a tappet in special tool (Tappet Pincers), remove the special tool (Roller Pincers), and then take out the tappet 9 and shim 10.

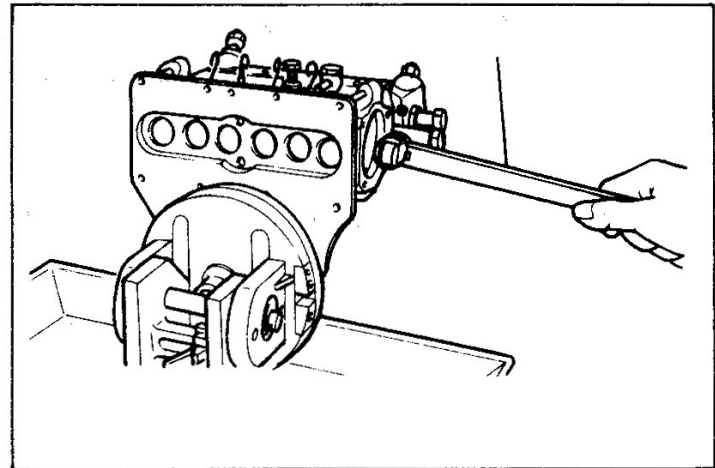

- (l) Remove the plunger 11 together with the lower spring seat 12, using special tool (Plunger Pincers).

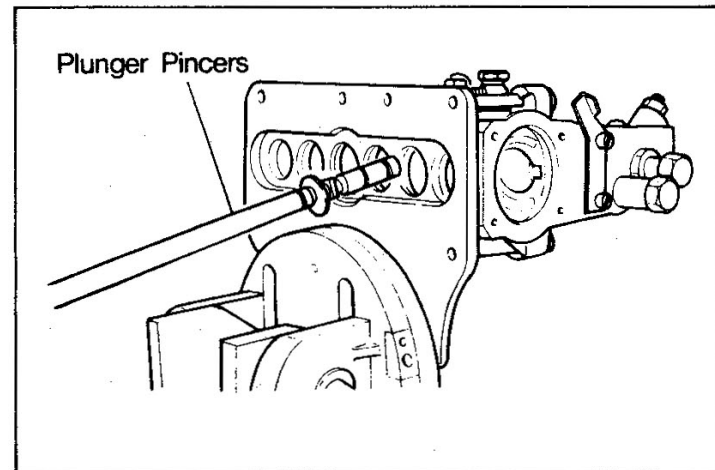

- (m) Measure the backlash between the control rack and pinion. If the backlash is in excess of the service limit, replace.

- (n) Remove the following parts.

- 17 Lock plate
- 18 Delivery valve holder
- 19 Stopper
- 20 Delivery valve spring

Use special tool (Wrench) to remove the delivery valve holder.

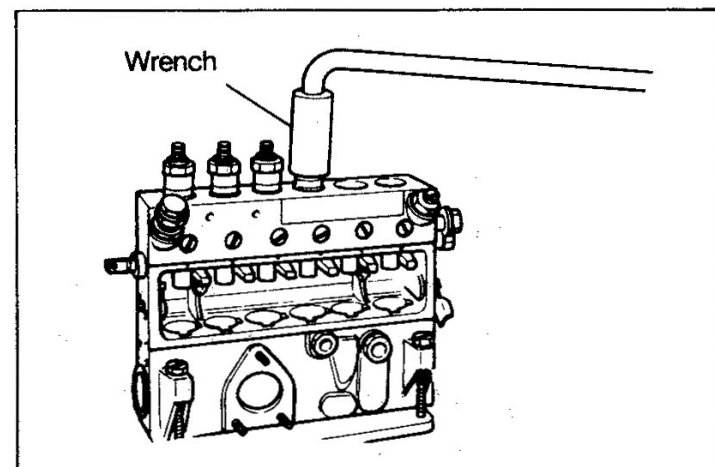

NOTE: Immerse the delivery valve combined with delivery valve seat and the plunger combined with plunger barrel in gas oil without changing their combinations.

(2) Inspection and Correction

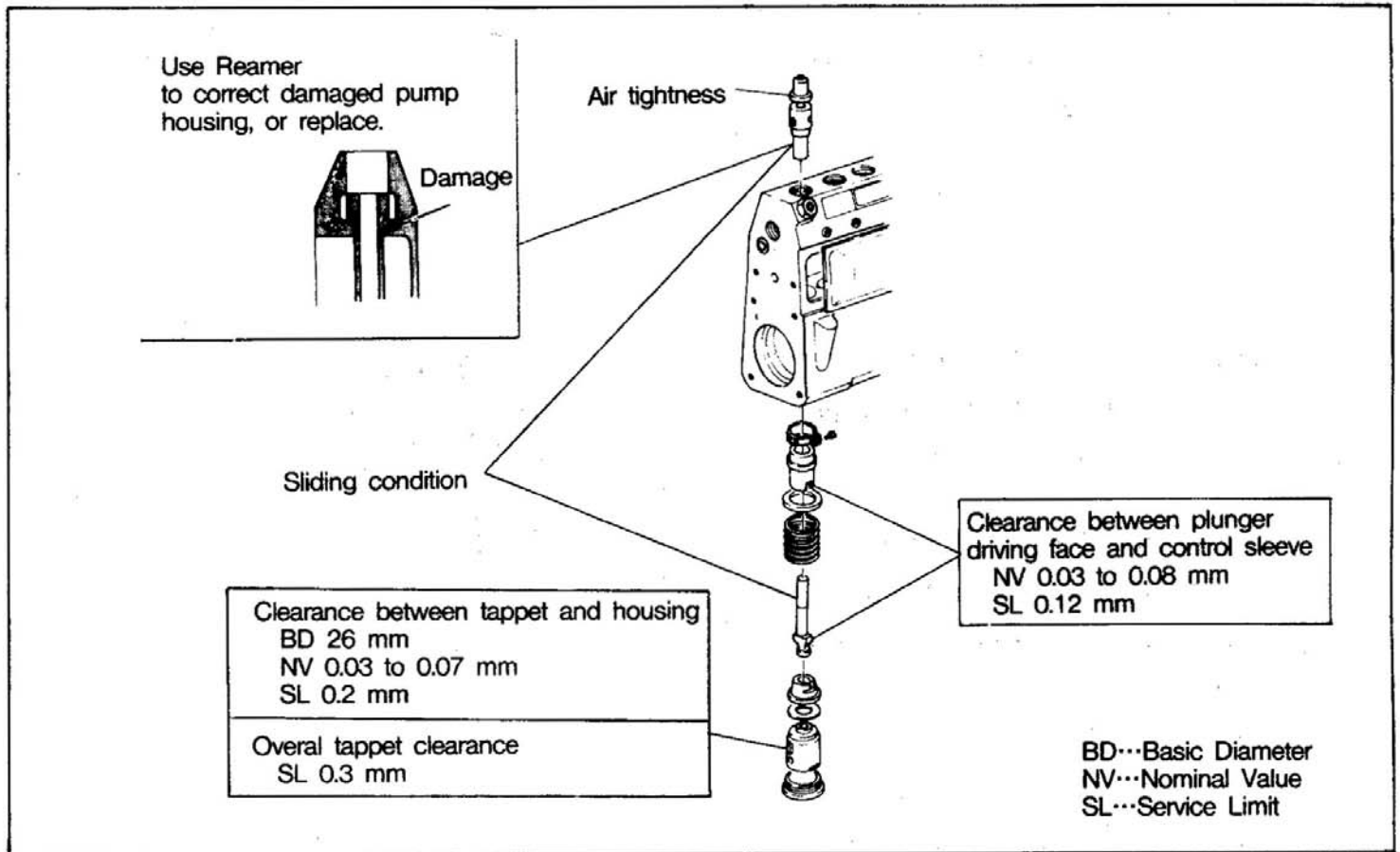

(a) Plunger and plunger barrel

After cleaning in gas oil, check to see that the plunger falls smoothly in the plunger barrel under its own weight.

Check by the following procedure.

- 1) Tilt the plunger barrel approx. 60°.
- 2) Pull the plunger about 20mm out.
- 3) Turn the plunger and check several points.

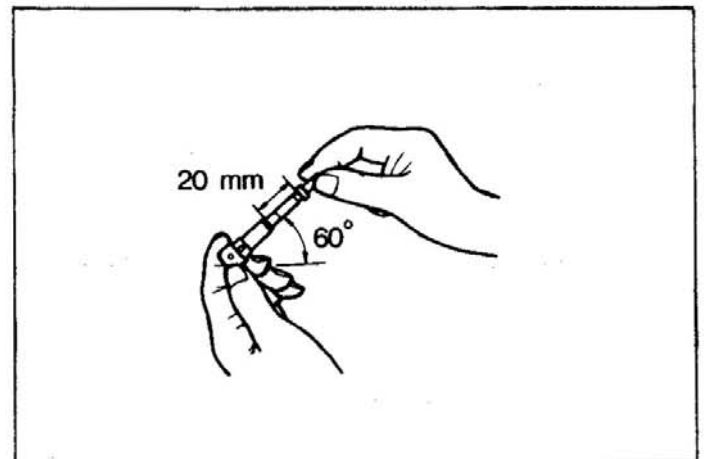

Measure the width between the driving faces of the plunger and the width of the groove in the control sleeve. If the calculated clearance between driving face and groove is in excess of the service limit, replace the control sleeve.

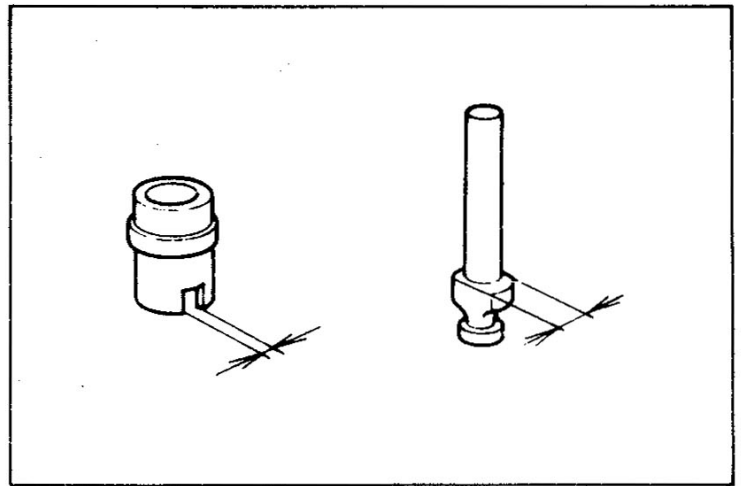

(b) Delivery valve

Clean the valve and valve seat portions of the delivery valve in gas oil and check worn condition.

Seal off the bottom of the valve seat portion with a finger tip and press down the valve portion with a finger. If the valve portion bounces back when released, the valve portion is good. If it does not bounce back, the valve portion is badly worn. Replace the delivery valve.

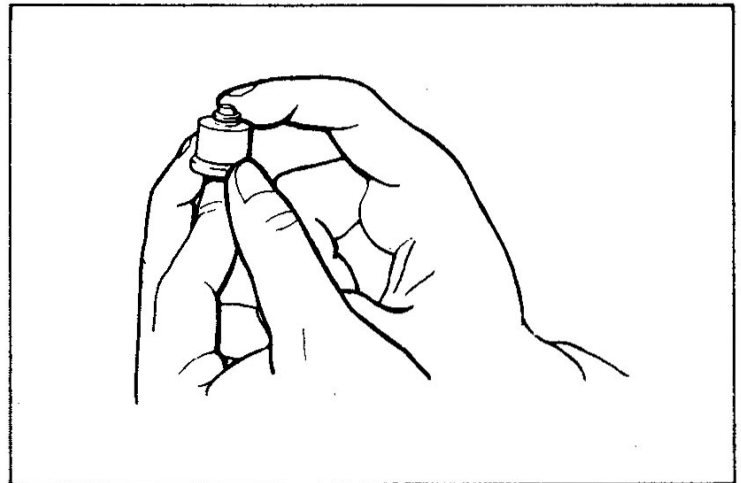

(c) Tappet

Hold a dial gauge to the roller portion of tappet and check the overall clearance by moving the roller up and down.

If the overall clearance is in excess of the service limit, replace the tappet assembly.

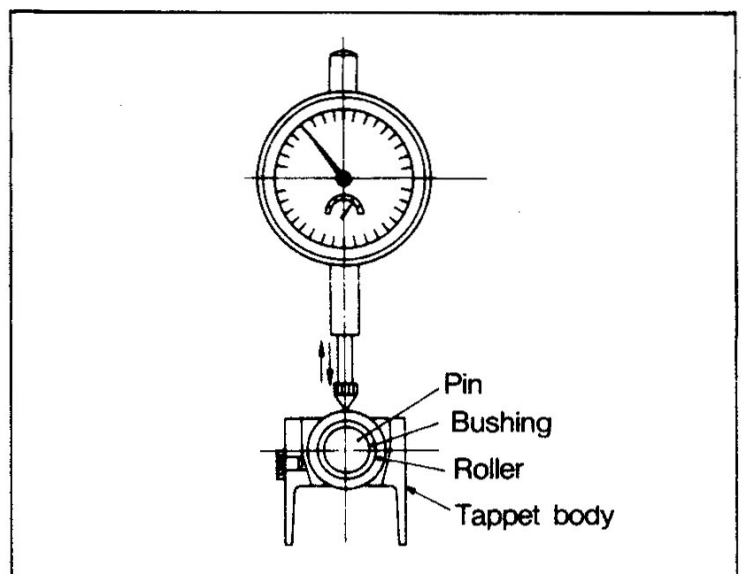

Calculate the clearance between the tappet and pump housing.

If the clearance is in excess of the service limit, replace parts.

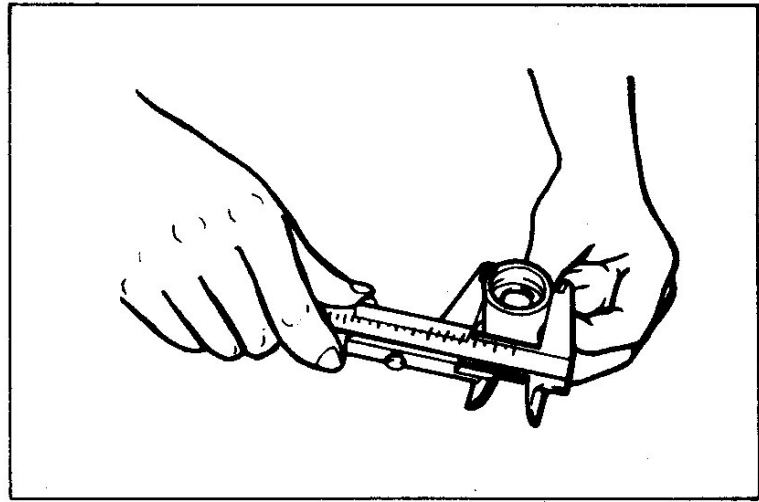

(d) Plunger spring and delivery spring

Measure the squareness and free length of the springs. A spring which has reached the service limit should be replaced.

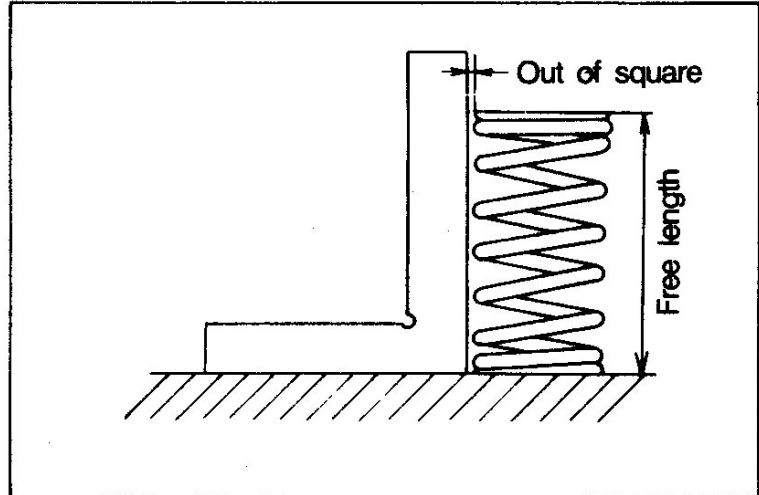

(e) Replacement of taper roller bearing

Inner race

To remove, use special tool (Extractor).

To install, put the ring and shims and then install the taper roller bearing.

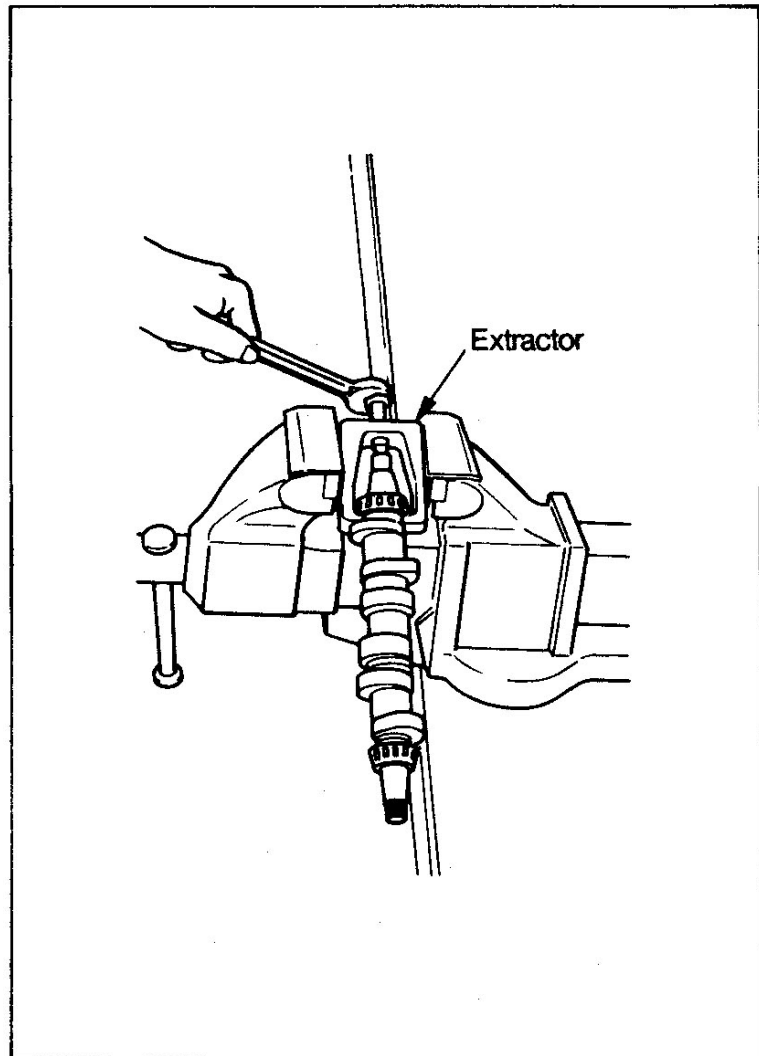

Outer race

The bearing cover side outer race should be removed by use of special tool (Outer Race Extractor).

To install, put a new oil seal in position, and then install the outer race.

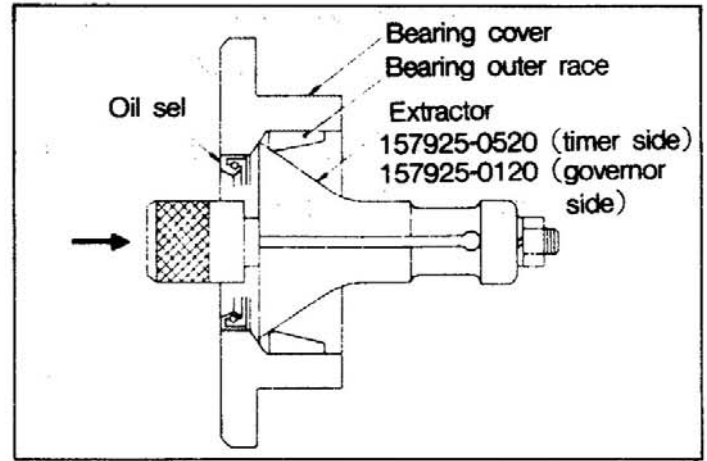

(3) Reassembly

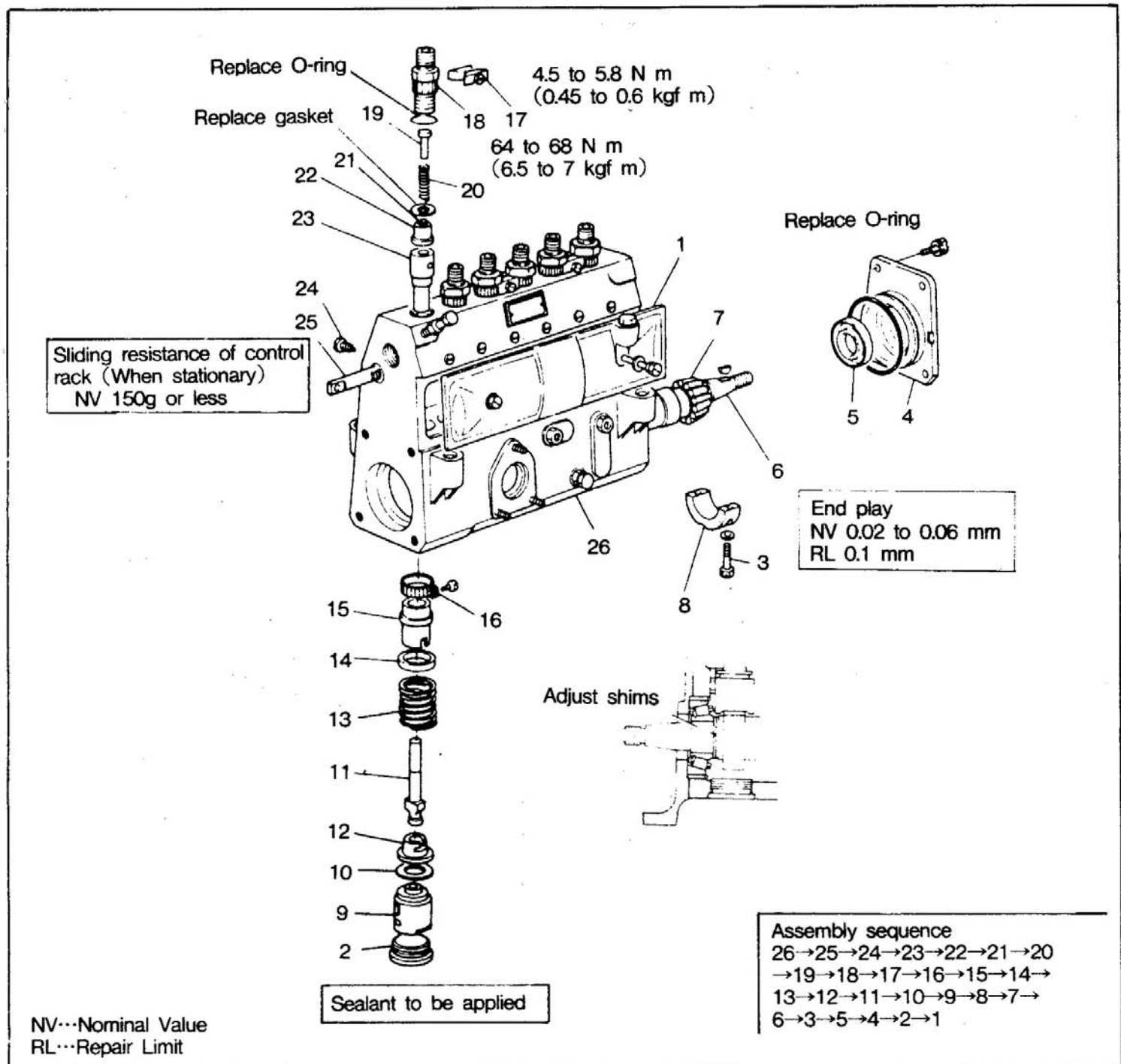

- (a) Mount the pump housing 26 in special tool (Universal Vice). After the control rack 25 has been inserted, thread the screw 24 into the back of the pump housing.

Check to see if the control rack lightly operates.

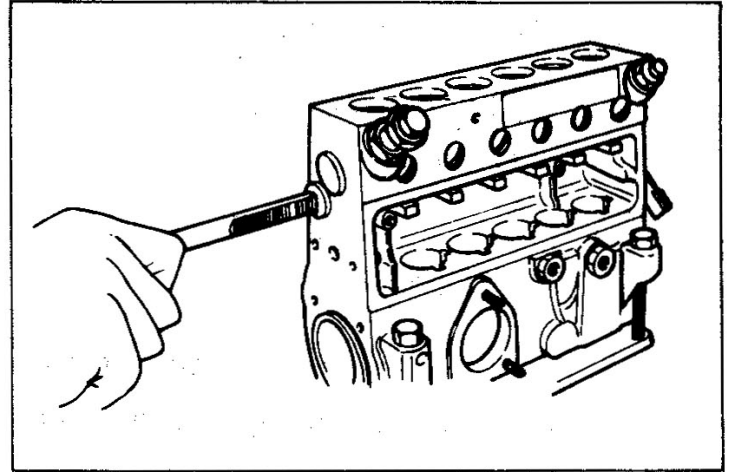

- (b) Insert the plunger barrel 23 into the housing.

NOTE : 1. Align the notch of the plunger barrel with the dowel pin of the housing.

2. Do not lightly strike the plunger barrel but securely push in by finger.

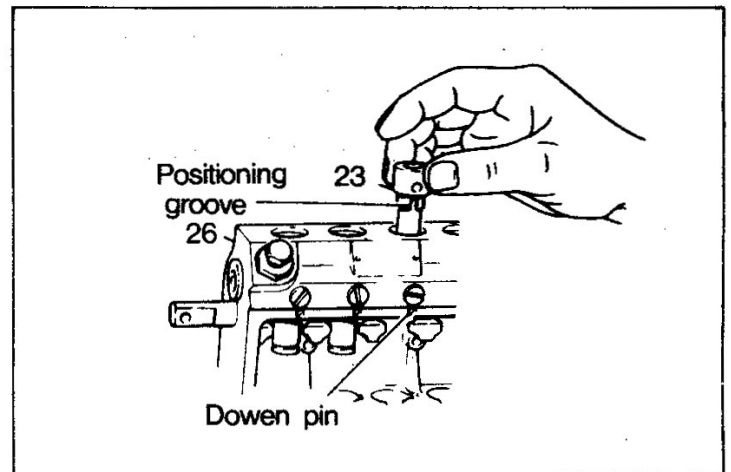

- (c) Place the pump housing on its side and set the control rack so that the punched marks of the control rack will be positioned the same dimension away from the ends of the housing. After the pinion 16 and control sleeve 15 have been combined, put the pinion in mesh with the teeth of the control rod.

NOTE : 1. Install the pinion and control sleeve so that the joint of the pinion and notch of the control sleeve will be faced toward you.

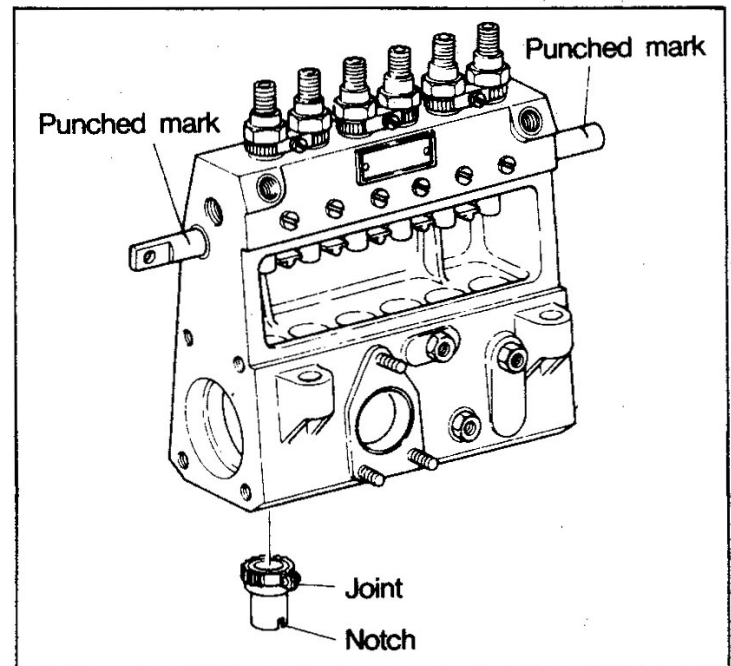

2. After each pinion has been installed, move the control rack to confirm that it can be moved the same amount to right and left.

(d) Install the following parts.

- 14 Upper spring seat
- 13 Plunger spring
- 12 Lower spring seat
- 11 Plunger

Install the lower spring seat and plunger together, using special tool (Plunger Pincers).

NOTE : Install the plunger with the stamped model number toward you (the housing cover).

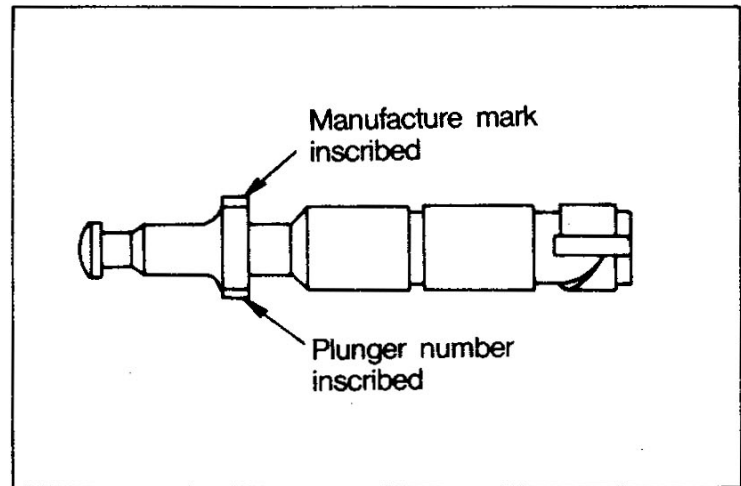
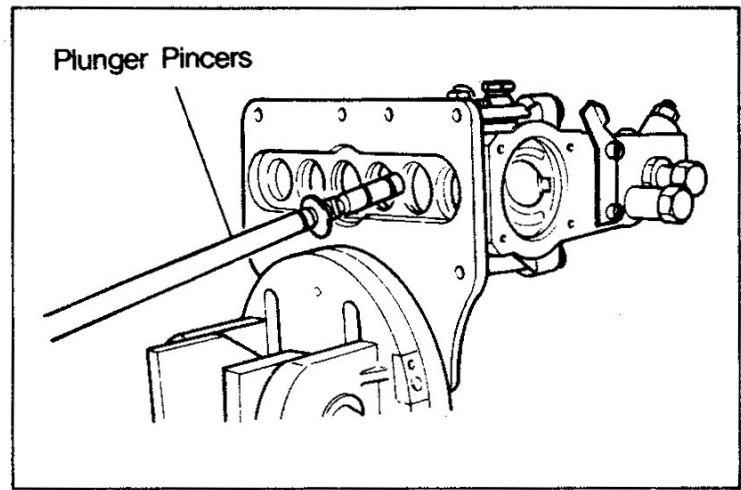

(e) Hold the tappet 9 and shim 10 in special tool (Tappet Pincers) and insert into the housing.

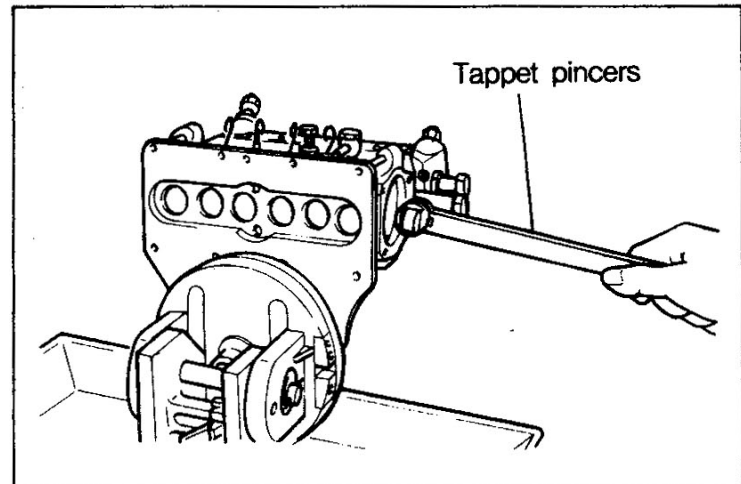

(f) Push the tappet inserted into the housing up with special tool (Roller Pincers) and insert special tool (Tappet Pin) into the hole in the tappet.

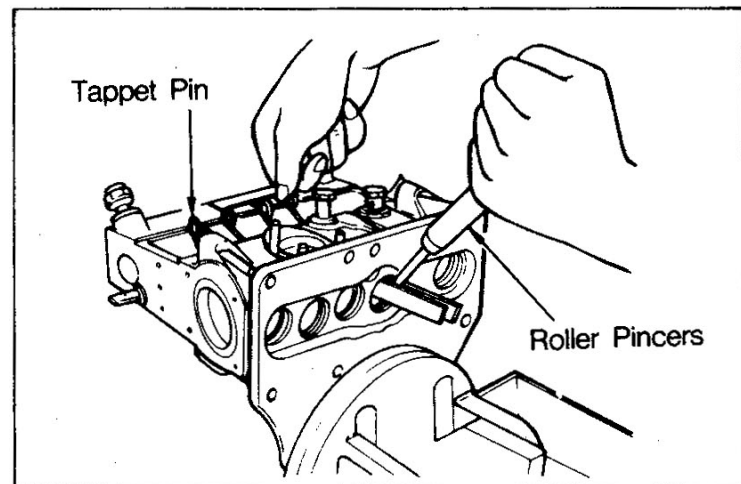

NOTE : When the camshaft is inserted, face the inscribed line on the end of the camshaft toward the timer.

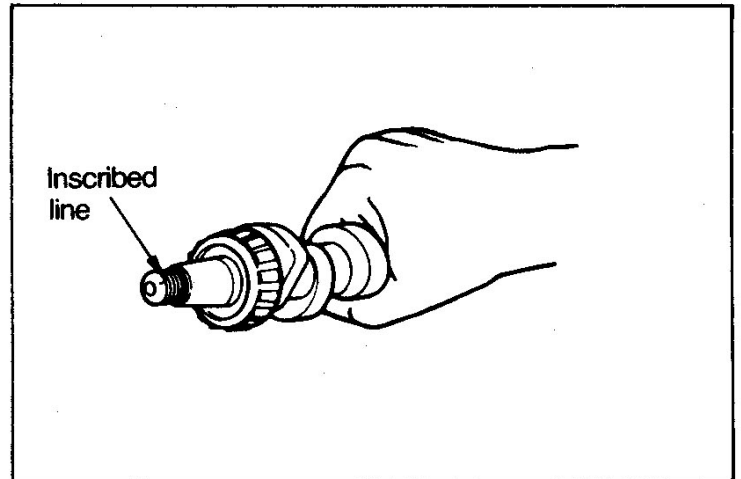

(g) Confirm the following items.

- 1) End play of camshaft [Refer to 11-1-1 (1) (g).]
- 2) Sliding resistance of control rack [Refer to 11-1-1 (1) (e).]

Check after removal of the special tool(Tappet Pin).

(h) Install the following parts.

- 5 Oil seal
- 4 Cover
- 2 Screws
- 1 Cover

Install the screws, using special tool(Wrench).

(i) Install the following parts.

Governor(Refer to Para. 11-1-3.)

Feed pump

Automatic timer(Refer to Para. 11-1-6.)

Coupling

(j) After the reassembly has been completed, adjust the injection pump.

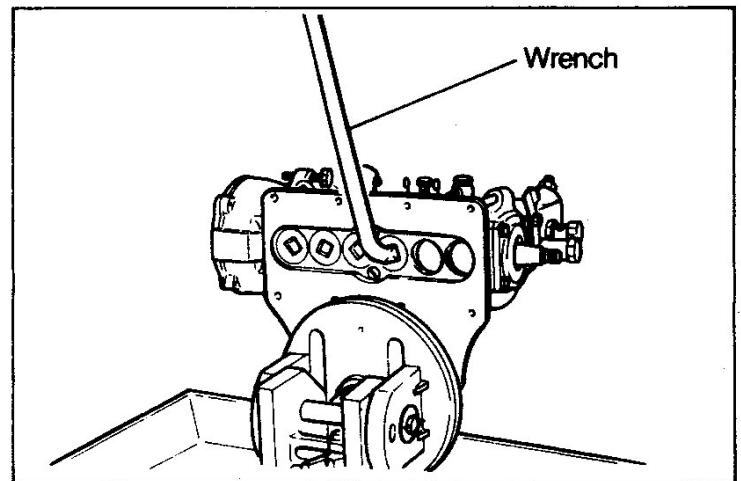

11-1-2 P Type Injection Pump

In servicing the injection pump, clean the work bench and arrange all disassembled parts neatly by cylinders. Use special care not to change the combination of the plunger and plunger barrel and that of the delivery valve and delivery valve seat.

Disassemble and reassemble the major parts with utmost care.

For disassembly and reassembly, be sure to use the ZEXEL Injection Pump Special Tool Set and avoid application of an undue force and rough operations.

Prior to disassembly, perform tests to fully grasp all defective points.

(1) Disassembly

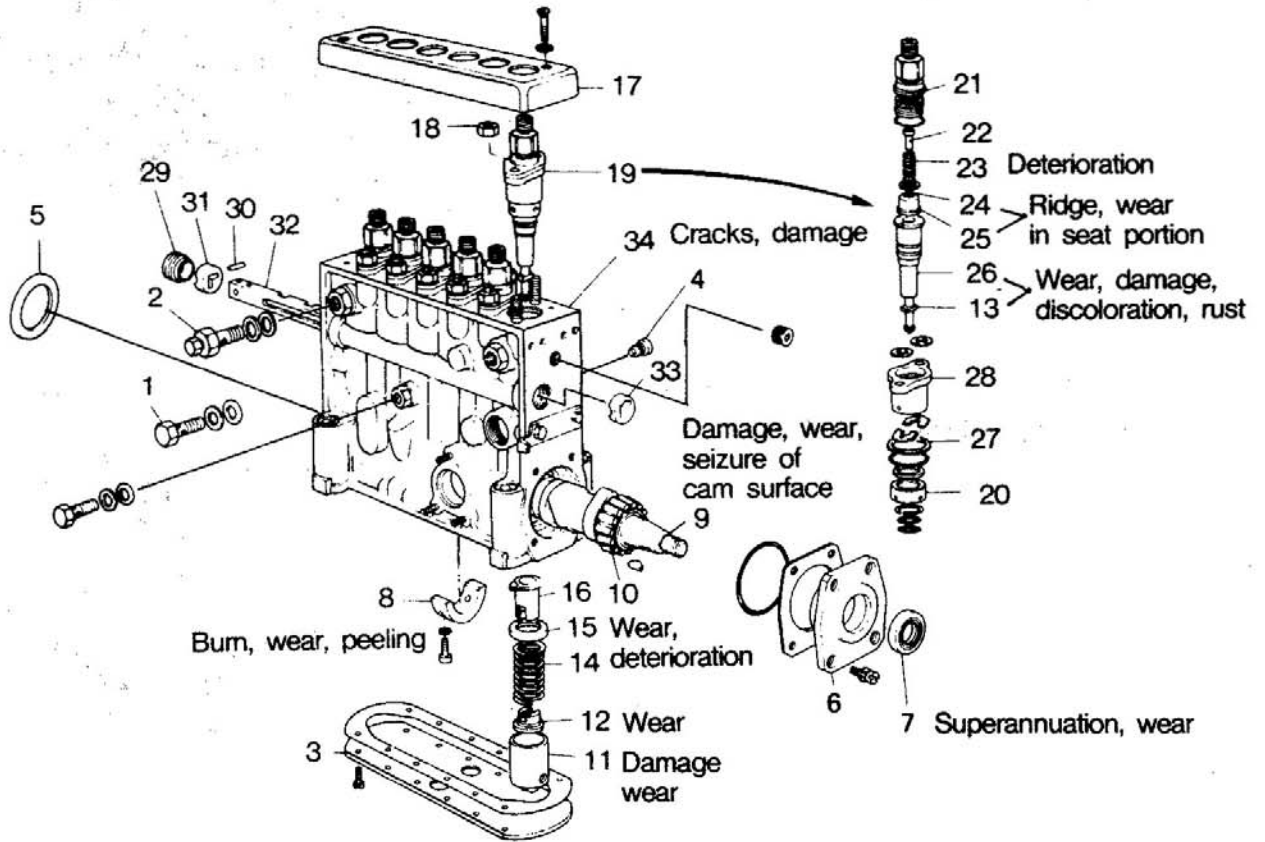

- | | |
|------------------------------|--------------------------|
| 1 Pipe joint bolt | 18 Nut |
| 2 Overflow valve | 19 Plunger lock assembly |
| 3 Bottom cover | 20 Deflector |
| 4 Screw plug | 21 Delivery valve holder |
| 5 Shim | 22 Stopper |
| 6 Bearing cover | 23 Delivery valve spring |
| 7 Oil seal | 24 Delivery valve |
| 8 Center bearing | 25 Delivery valve seat |
| 9 Camshaft | 26 Plunger barrel |
| 10 Roller bearing inner race | 27 Distance ring |
| 11 Tappet assembly | 28 Flange sleeve |
| 12 Lower spring seat | 29 Screw bushing |
| 13 Plunger | 30 Pin |
| 14 Plunger spring | 31 Bushing |
| 15 Upper spring seat | 32 Control rod |
| 16 Control sleeve | 33 Bushing |
| 17 Cover | 34 Pump housing |

(a) Remove the feed pump.

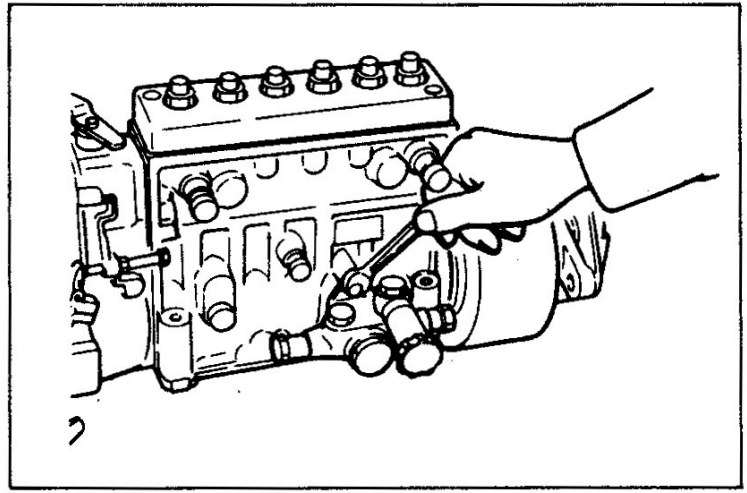

(b) Install special tool(Fitting Plate) in special tool(Universal Vice).

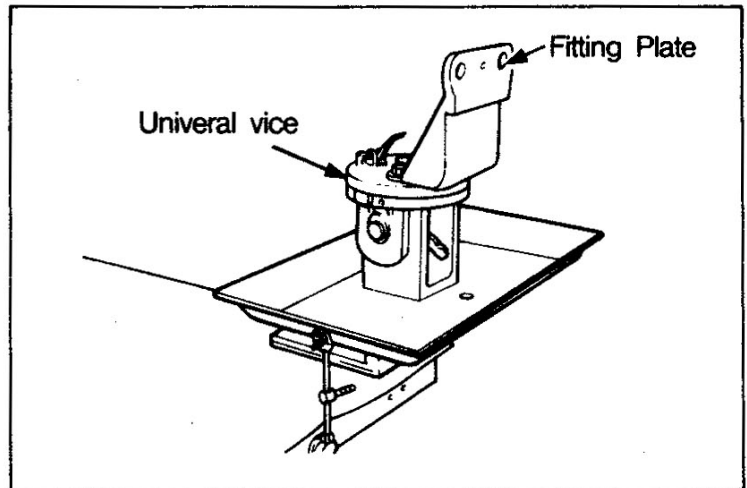

(c) Remove the pipe joint bolt 1 and overflow valve 2 from the fuel inlet of the injection pump. Utilizing the threaded hole, install special tool (Plate).

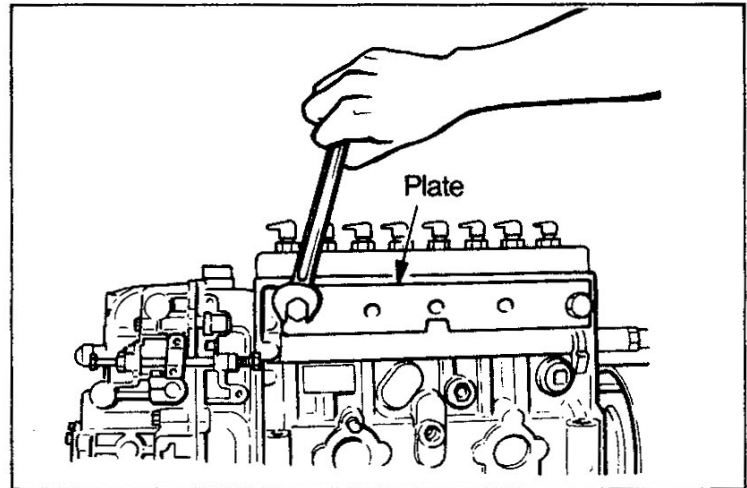

(d) Install the injection pump in special tool(Universal Vice).

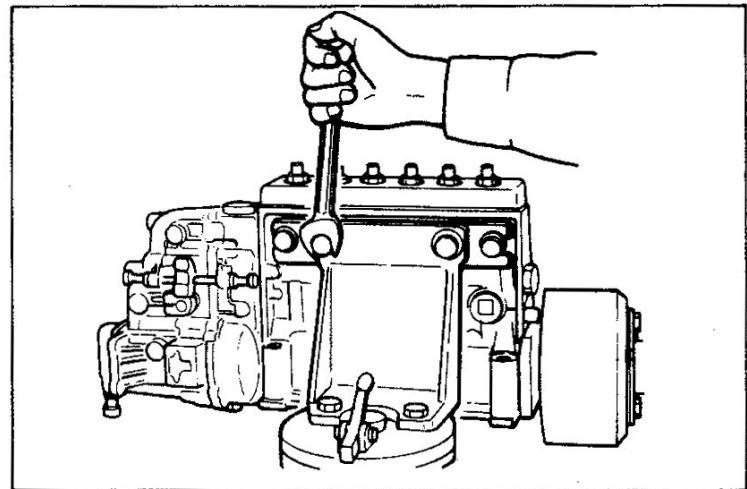

(e) Remove the screw plug 4, turn the camshaft to place the tappet at the top dead center position, and insert special tool(Tappet Holder) into the screw plug hole to space the tappet away from the camshaft.

(f) Remove the coupling.

(g) Remove the automatic timer.

(Refer to Para. 11-1-7).

(h) Remove the governor.

(Refer to Para. 11-1-3 or 11-1-4).

(i) Remove the bearing cover 6, using special tools(Bracket) and (Bearing Cover Extractor).

NOTE : 1. When the bearing cover is removed, use care not to lose the end play adjusting shims.

2. Check the oil seal 7 and do not remove it unless defective.

(j) Install special tool(Tappet Mounting Device) to the pump housing.

Then operate the lever to push the tappet up, remove the special tool (Tappet Holder), and take out the tappet assembly 11.

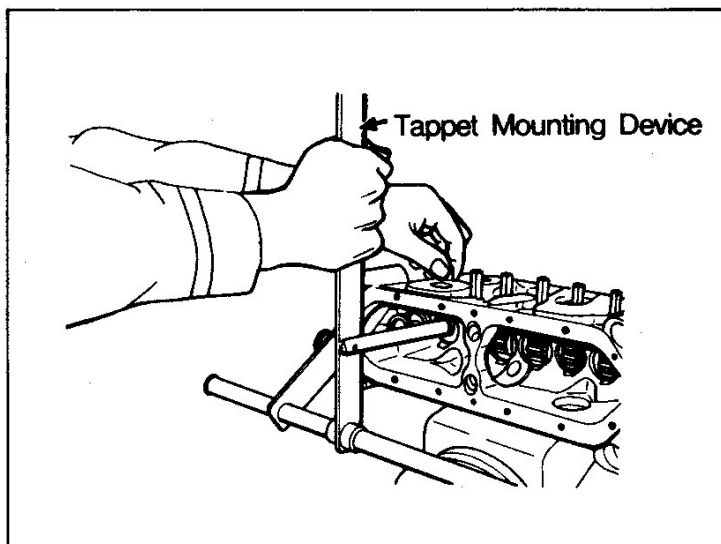
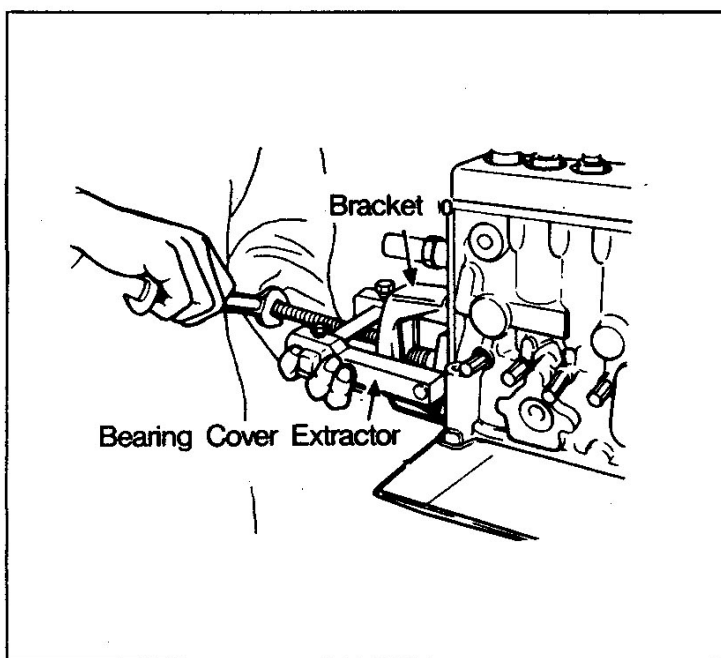
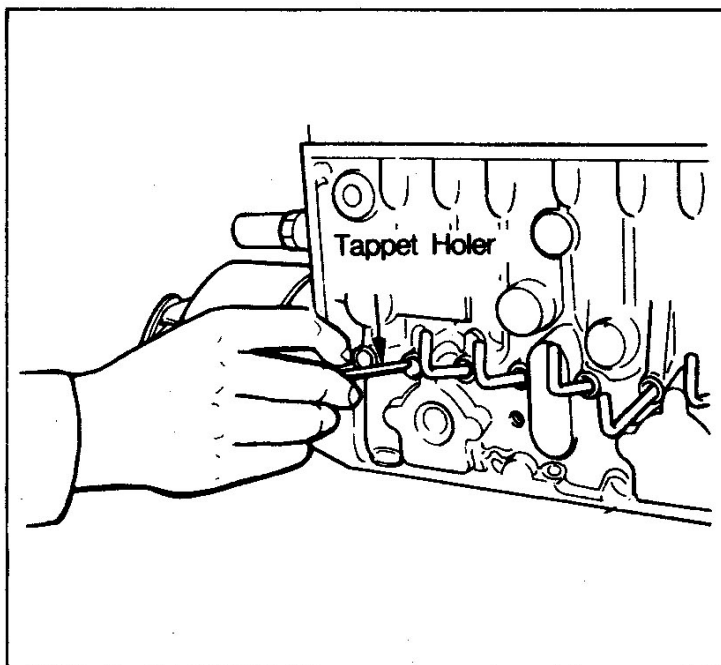

(k) Remove the special tool (Tappet Mounting Device), install a wire in the hole of the lower spring seat 12, pull it together with the plunger until the lower spring seat can be removed, and remove only the lower spring seat.

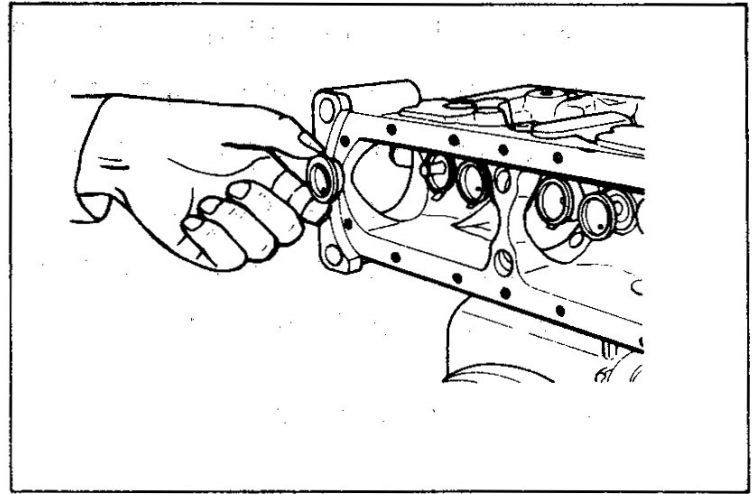

(l) Remove the plunger 13, using special tool (Plunger Insert).

NOTE : Put the removed plungers orderly in a tray containing clean gas oil.

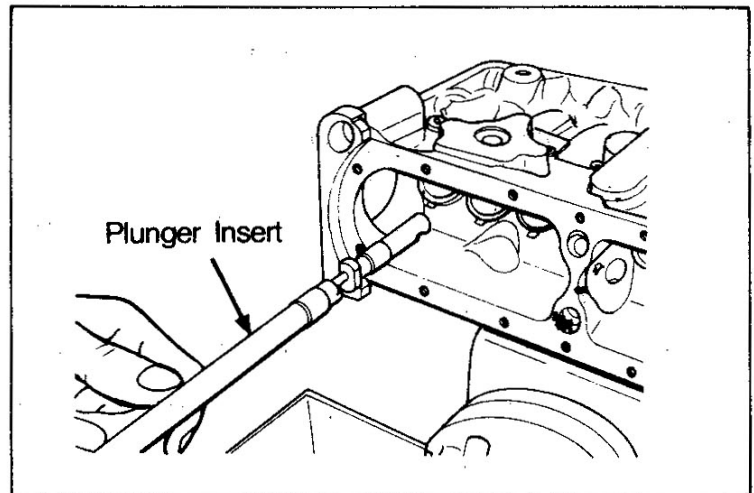

(m) Remove the upper spring seat 15 and control sleeve 16. The control sleeve can be easily removed by use of special tool (Plunger Clamp Device).

NOTE : The control sleeve cannot be removed unless the ball mounted on the flange of the control sleeve and the tappet guide groove in the pump housing are in alignment.

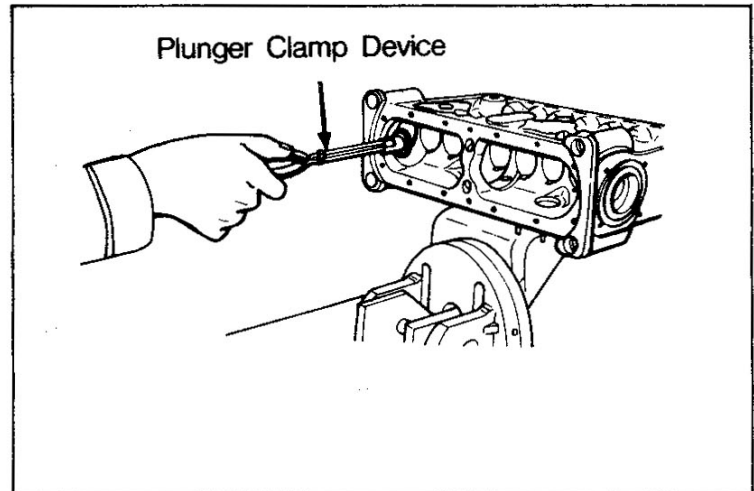

(n) Mount special tool (Extractor) to the delivery holder and remove the plunger block assembly 19.

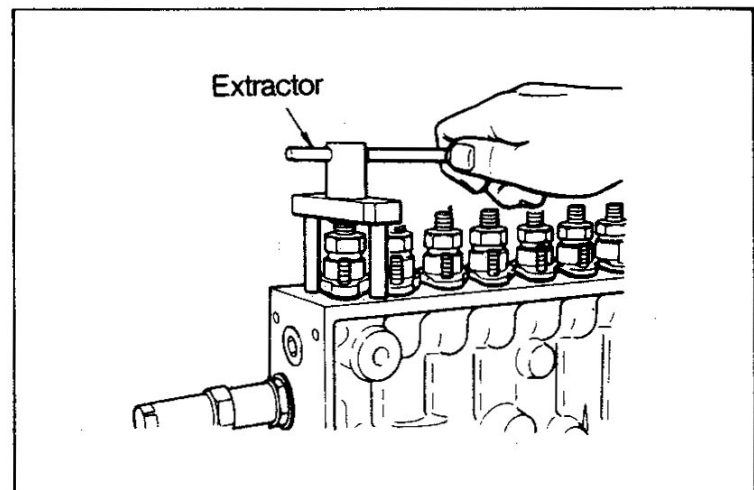

(o) Disassemble the plunger block assembly by the following procedure.

a) Mount special tool (Fitting Plate) in the vice.

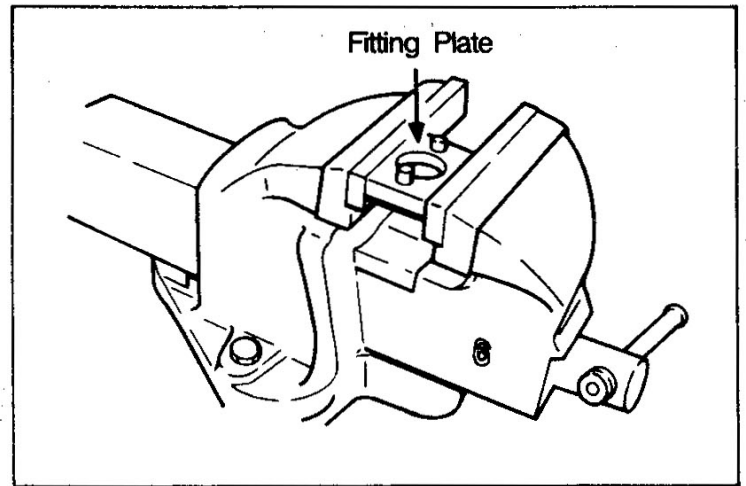

(p) Secure the plunger lock assembly to the special tool (Fitting Plate) and loosen the delivery valve holder with special tool (Socket Wrench).

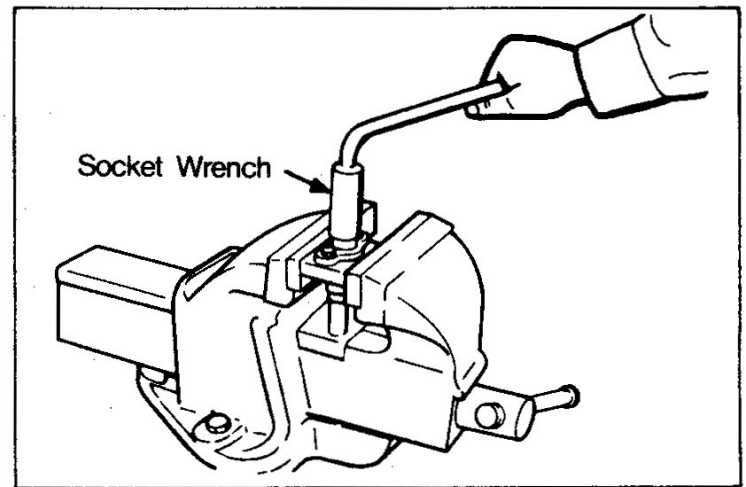

(q) Remove the governor side screw bushing 29 with special tool (Special Wrench) and remove the pin 30 and bushing 31.

Then remove the control rod 32 and bushing 33 from the timer side.

NOTE : 1. Arrange all removed parts orderly by cylinders.

2. Be sure not to change the combination of the paired plunger barrel and plunger and that of delivery valve and delivery valve seat.

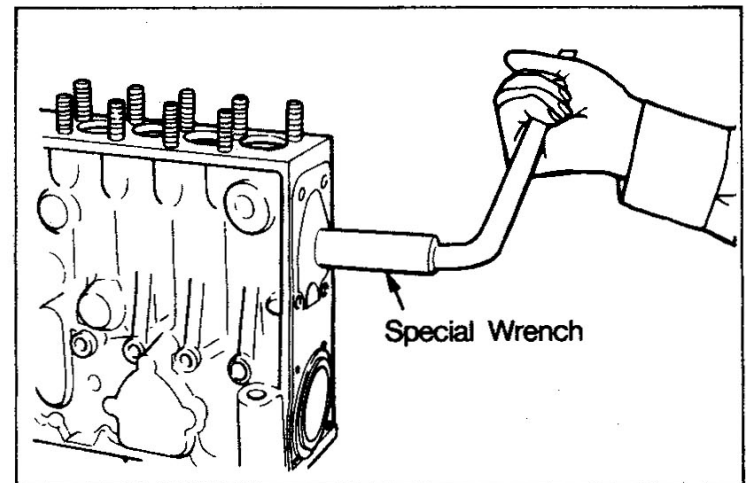

(2) Inspection and Correction

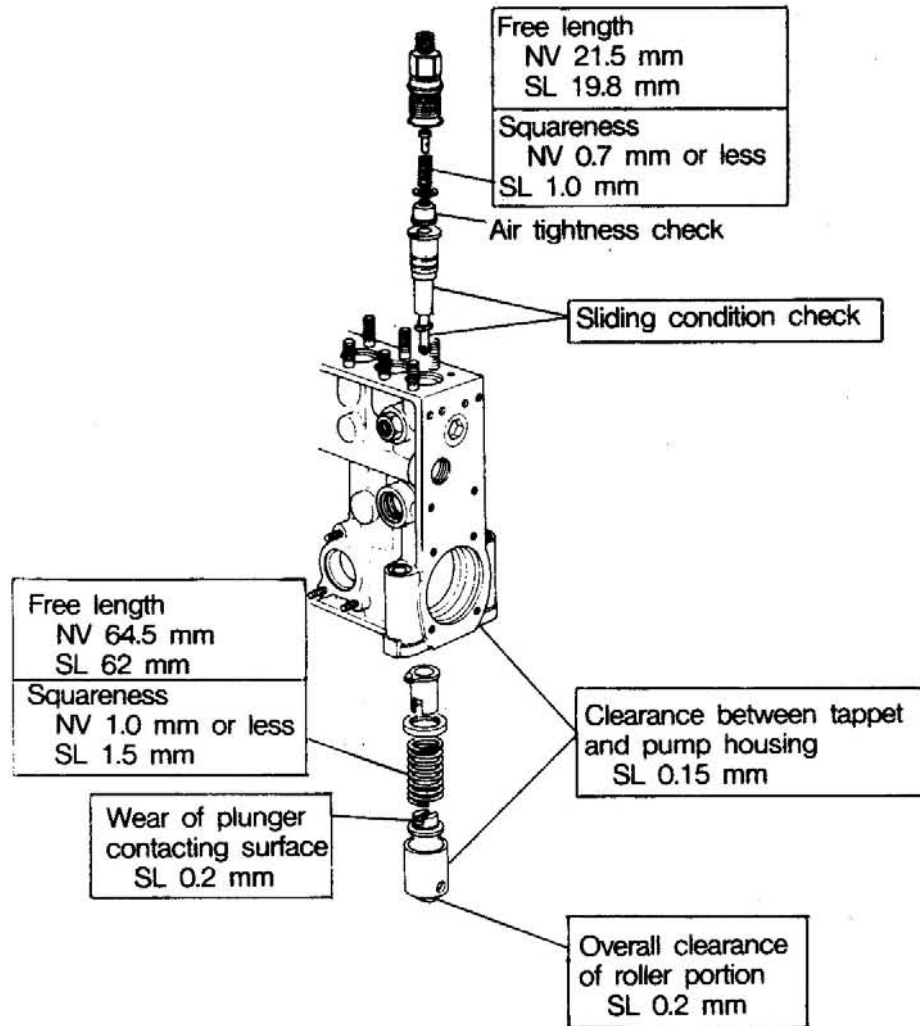

NV...Nominal Value
SL...Service Limit

(a) Plunger and plunger barrel

After the plunger and plunger barrel have been cleaned in gas oil, tilt the plunger barrel approx. 60° and pull the plunger half the way out and release. If it falls smoothly under its own weight, then the plunger and plunger barrel are good.

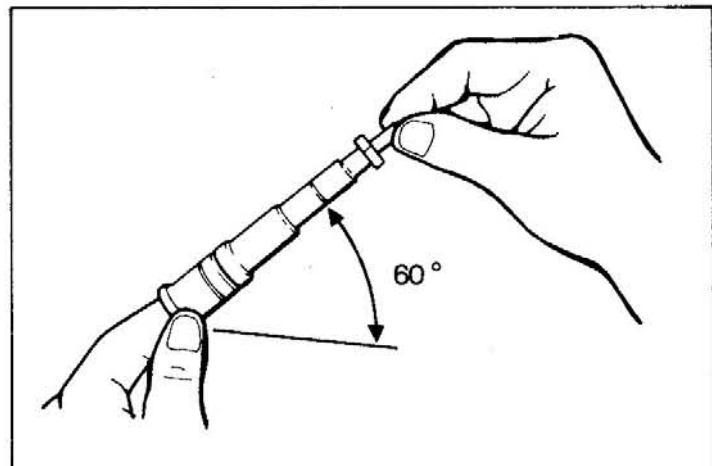

(b) Delivery valve

After cleaning the valve and valve seat portions of the delivery valve in gas oil, check the worn condition.

Seal off the bottom of the valve seat portion with a finger tip, press down the piston portion with a finger and release. If the piston portion bounces back, the delivery valve is good. If it does not bounce back, the delivery valve is badly worn. Replace the delivery valve.

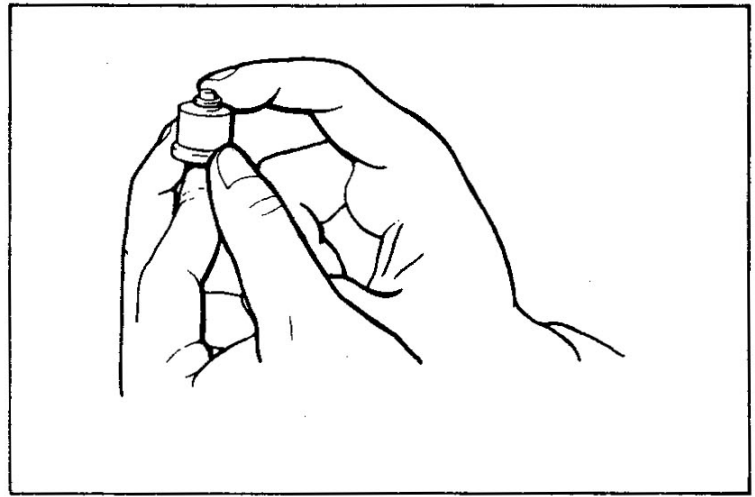

(c) Tappet

Hold a dial gauge to the roller portion of tappet and check the overall clearance by moving the roller portion up and down. If the overall clearance is in excess of the service limit, replace the tappet assembly.

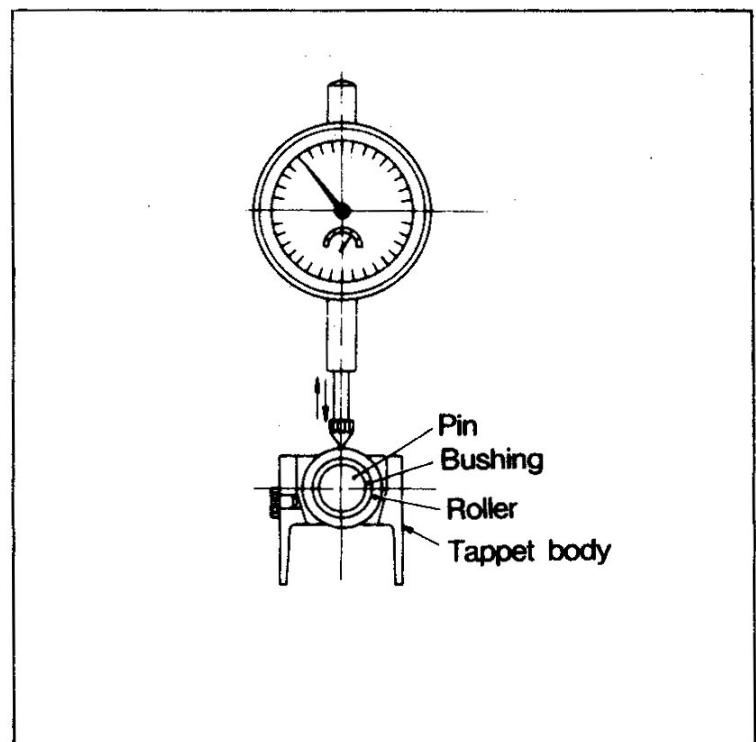

Check the clearance between the tappet and pump housing. If the clearance is in excess of the service limit, replace parts.

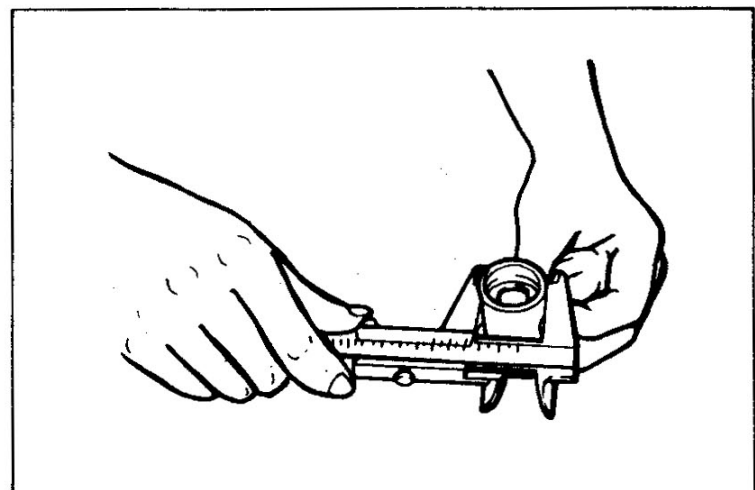

(d) Lower spring seat

Check the plunger contacting surface of the lower spring seat. If it is worn beyond the service limit, replace parts.

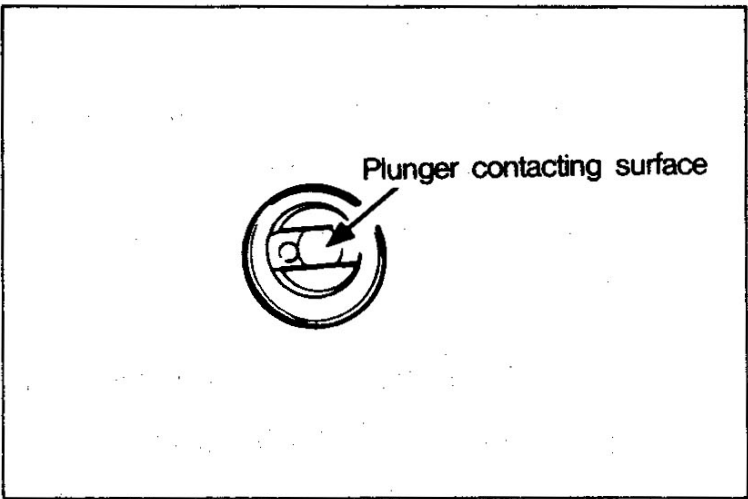

(e) Plunger spring and delivery valve spring

Measure the out of square (squareness) and free length of the springs. If they are beyond the service limits, replace parts.

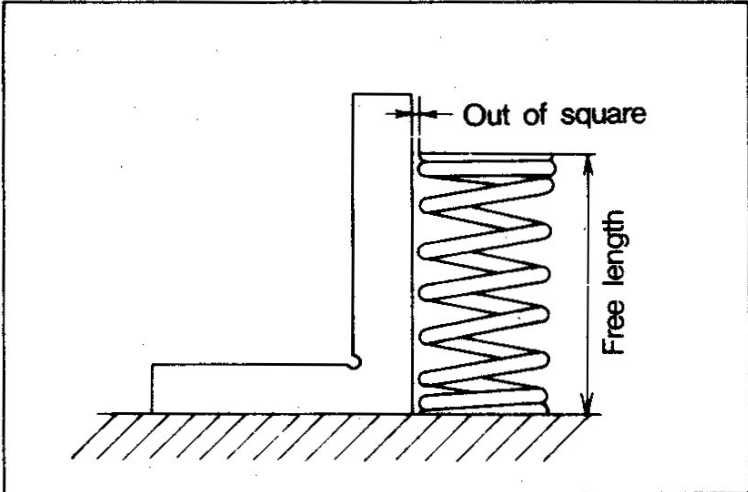

(f) Replacement of taper roller bearing

Inner race

Remove inner race by use of special tool (Inner Race Extractor).

To install, use press.

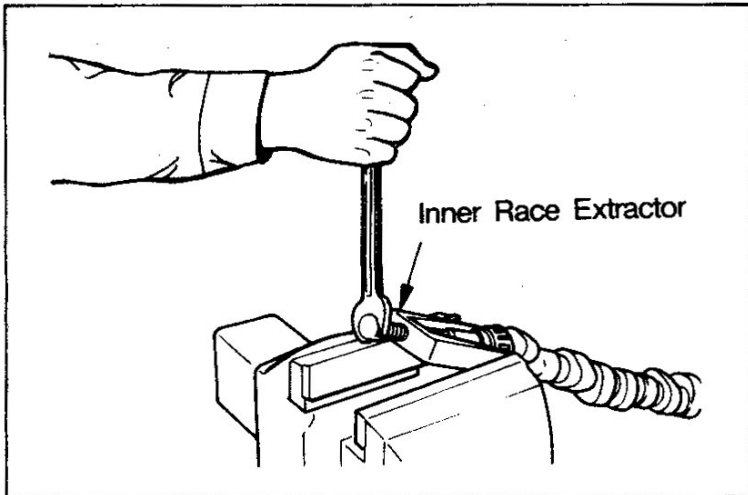

Outer race

Remove the bearing cover side outer race by use of special tool (Outer Race Extractor).

To install, install a new oil seal and then install the outer race.

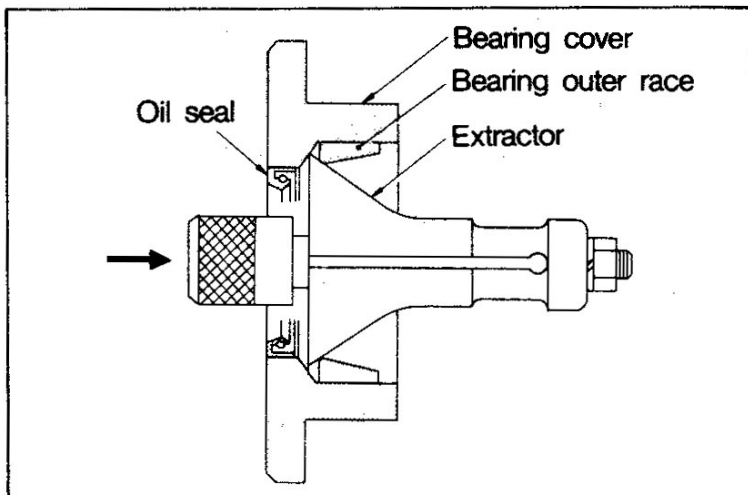

(3) Reassembly

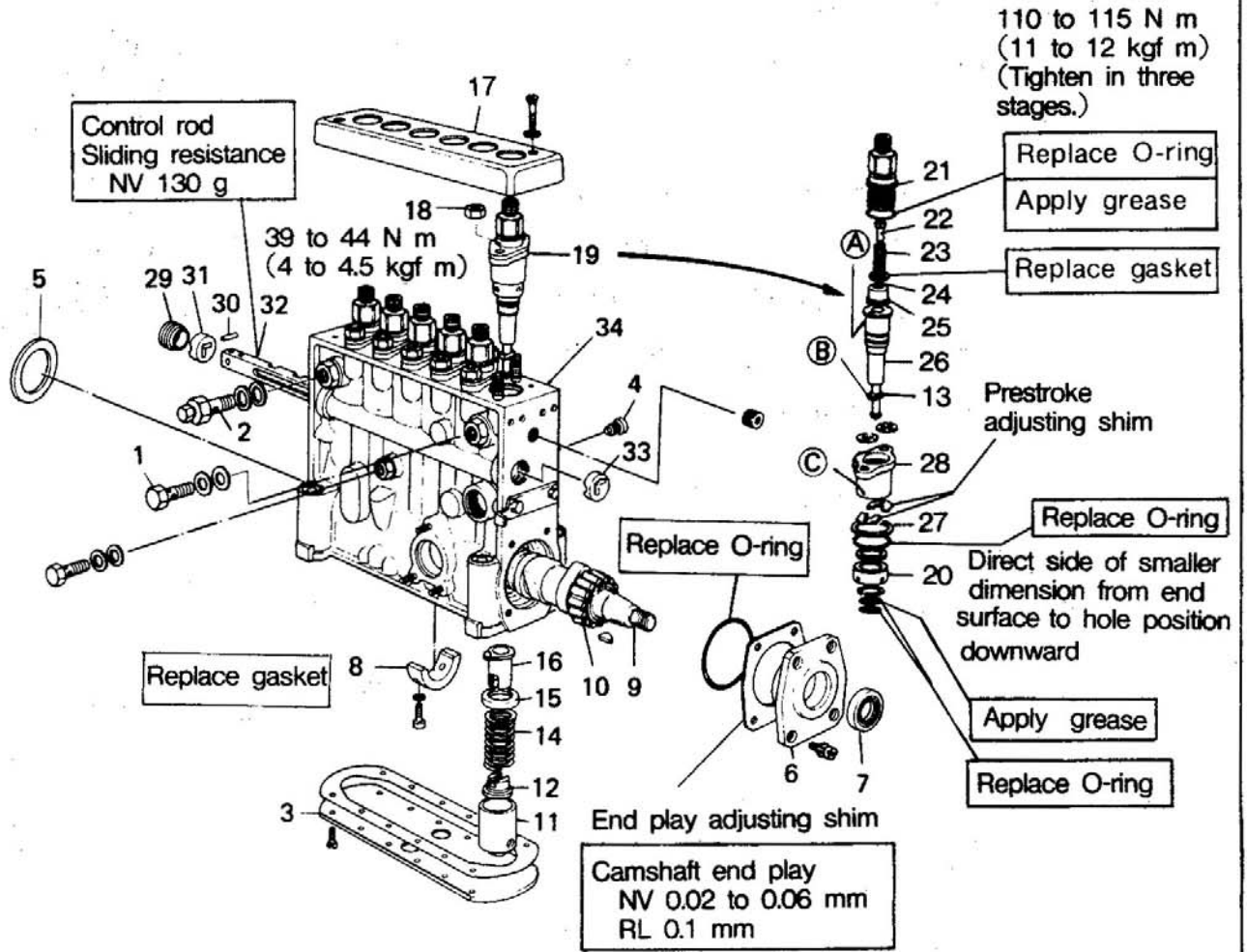

NV...Nominal Value
RL...Repair Limit

(a) Mount the pump housing 34 in special tool(Universal Vice).

Then install bushings 33 and 31, control rod 32, pin 30 and screw bushing 29 with special tool(Special Wrench). Check to see that the control rod lightly operates.

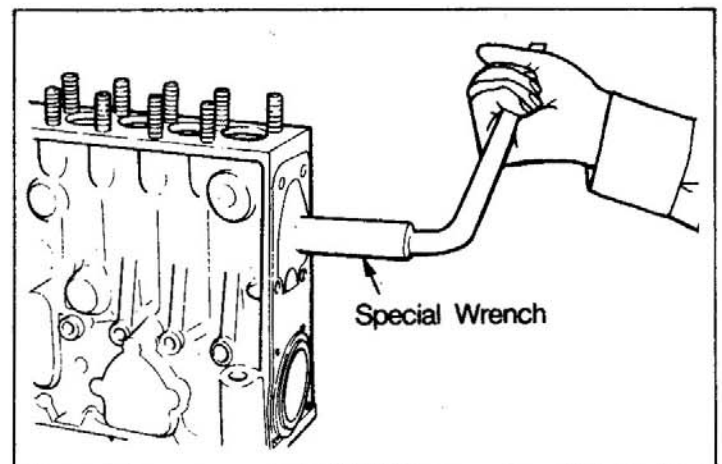

- (b) Install the O-ring on the upper side of the plunger barrel, and insert the lower side O-ring into the pump housing with special tool (O-ring Insert).

NOTE : Make sure that the lower side O-ring is not set on the plunger barrel and slid along the wall surface of pump housing.

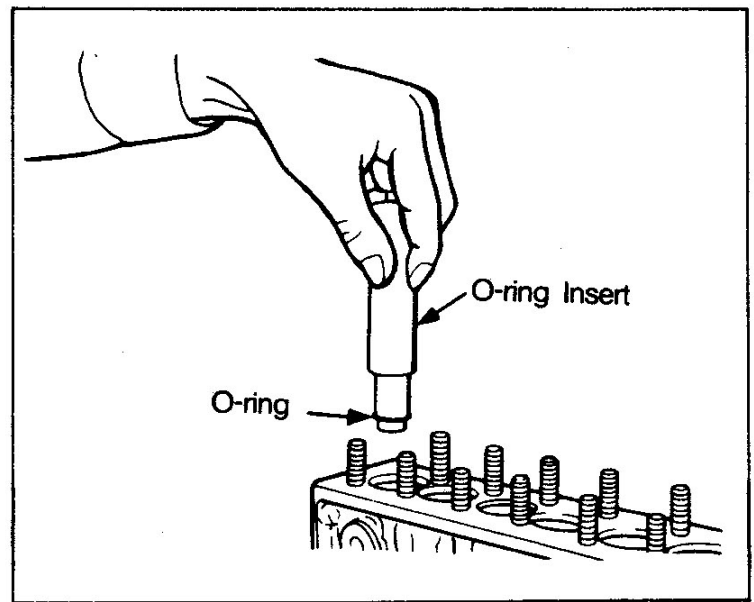

- (c) Using special tool(Socket Wrench), tighten the delivery valve holder to the specified torque(tighten in three stages).

NOTE : If the tightening torque is smaller than the specified torque, oil leakage or damage to the related parts could result.

If the tightening torque is excessive, unsmooth plunger movement or damage to the related parts could result.

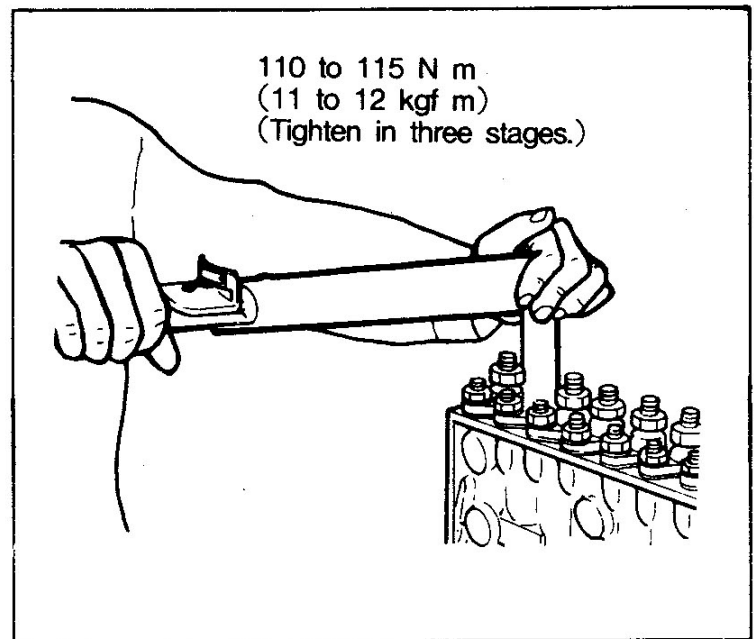

- (d) Mount the plunger 13 to special tool (Plunger Insert) and insert it into the plunger barrel.

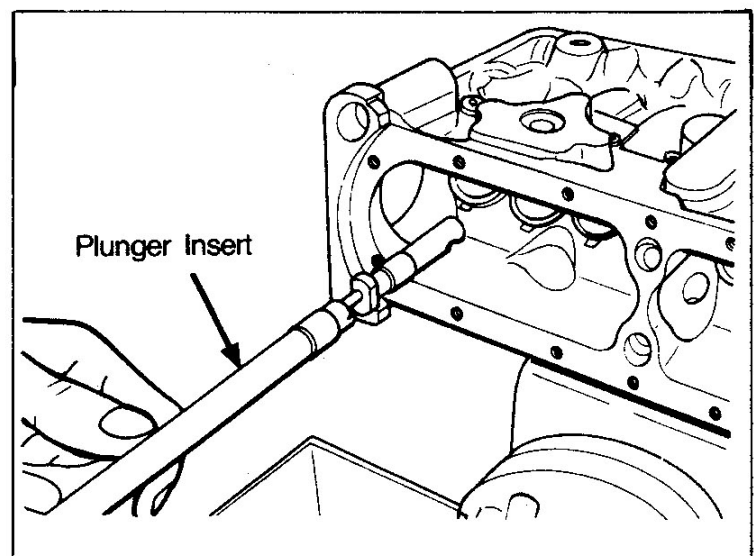

- (e) Mount special tool(Tappet Mounting Device) to the pump housing.

Then install the tappet by operating the Tappet Mounting Device.

At this time, compress the plunger spring and insert the mitt portion of the plunger into the guide groove in the control sleeve, and insert special tool(Tappet Holder) into the screw plug hole. The operation of inserting the mitt portion of the plunger into the guide groove of the control sleeve can be easily performed by inserting the mitt portion, while moving the control rod to right and left.

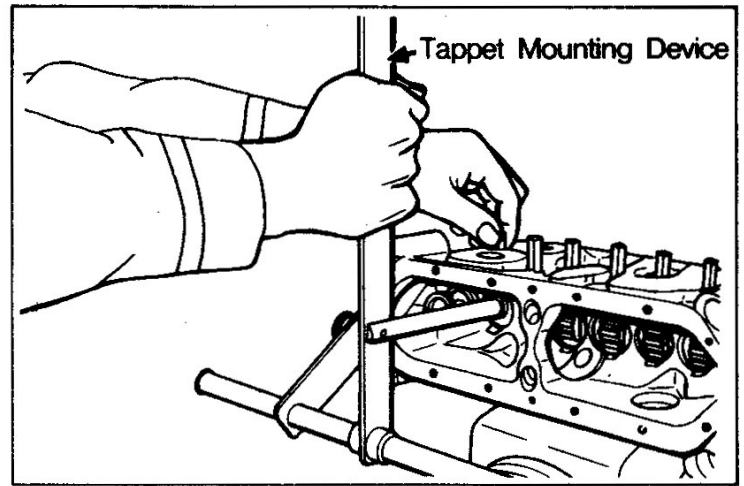

- (f) Insert the camshaft 9 from the timer side.

When the camshaft is installed, face the inscribed line of the end of the camshaft toward the timer side.

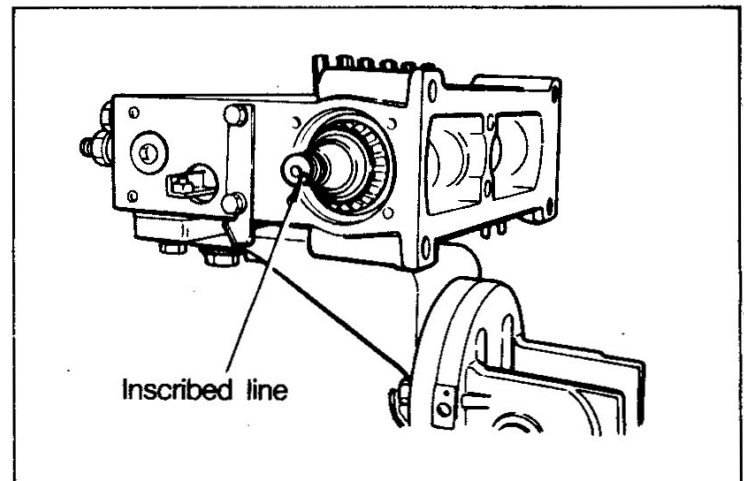

- (g) Install the governor housing. At this time, perform the following operations.

Mount special tool(Measuring plate) to the timer side taper portion of the camshaft, and install and position the governor side taper roller bearing outer race in the ring so that

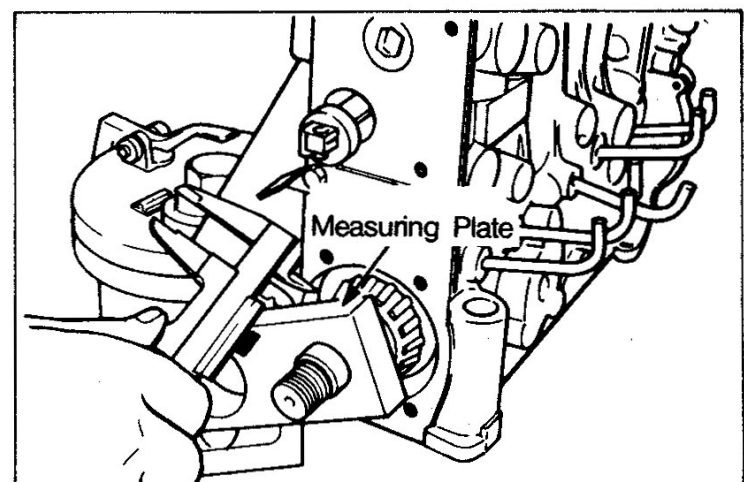

the dimension from the end of the pump housing to the end of the Measuring Plate will be 13.85 ± 0.5 mm.

Installation of the taper roller bearing outer race will produce a clearance between the governor housing and taper roller bearing outer race. Change shims to eliminate the clearance.

Shim thickness

0.6, 1.2, 1.5, 1.8, 2.0mm

(h) Measure the camshaft end play.

Install special tool (Camshaft Measuring Device) to the timer side of the camshaft to measure the end play.

If the camshaft end play is out of the nominal value, adjust by changing shims between the bearing cover and pump housing.

Shim thickness

0.10, 0.12, 0.14, 0.16, 0.18, 0.30, 0.50mm

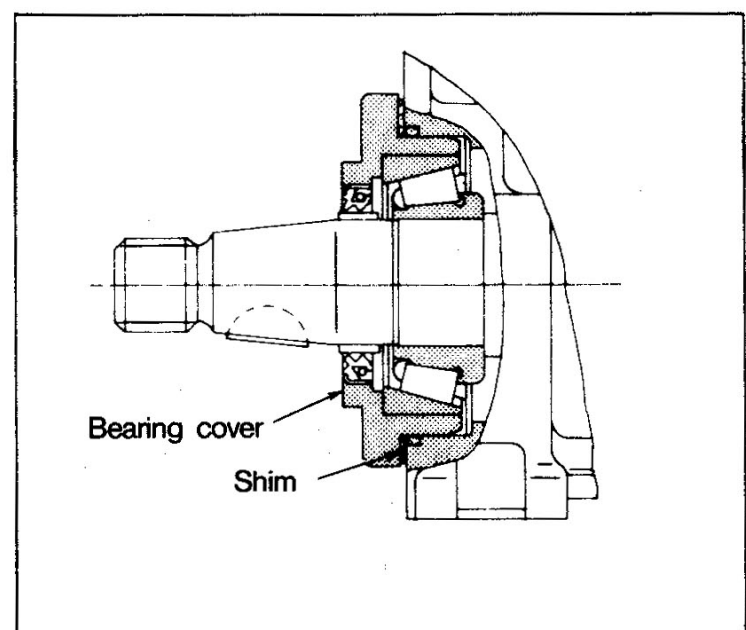
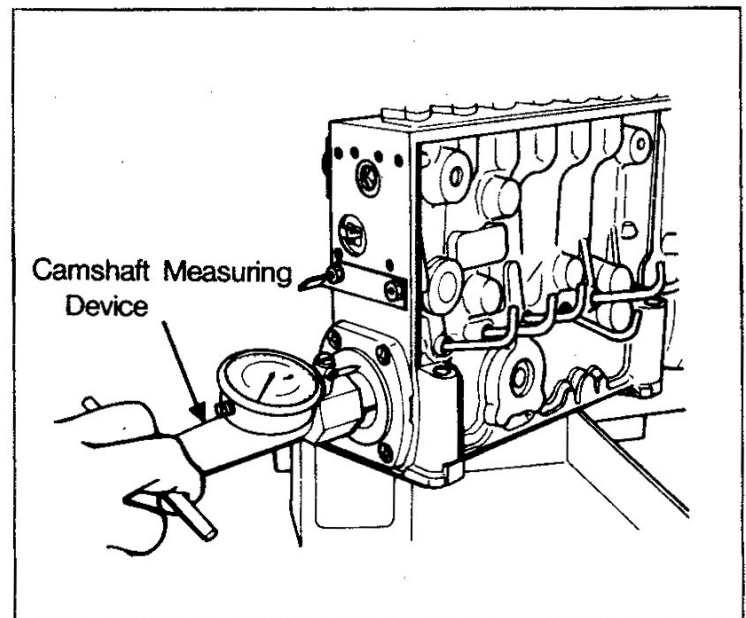
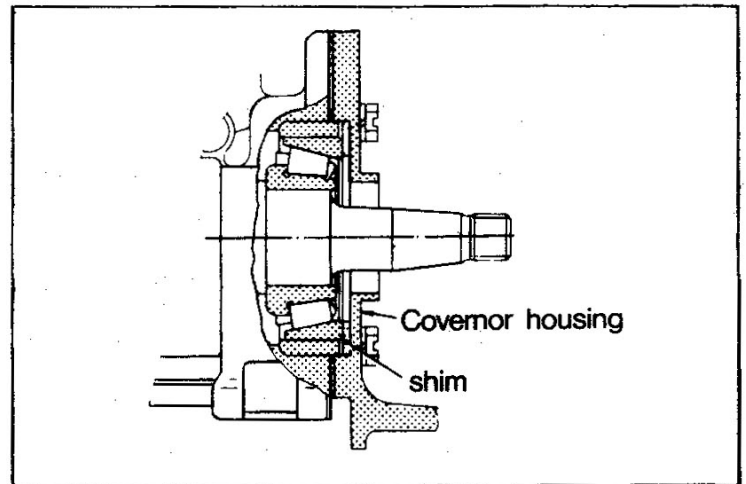

- (i) Install a spring balance to the control rod and check to see that the control rod slides smoothly over the entire stroke without exceeding the standard sliding resistance value.

Remove the special tool
(Tappet Pin) before checking.

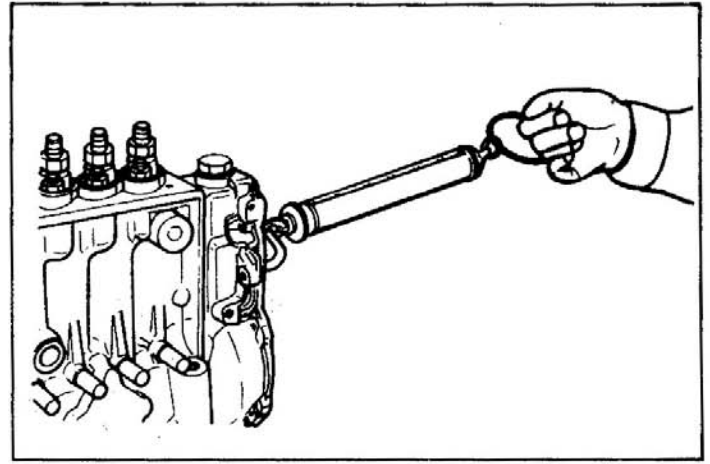

- (j) Install the following parts.

Governor(Refer to 11-1-3 or 11-1-4).

Feed pump

Automatic timer(Refer to 11-1-7).

Coupling

- (k) After reassembly has been completed, adjust the injection pump.

11-1-3 RSV Type Governor

Make sure that the disassembly operations are carefully performed. Clean the work bench and site beforehand. Prior to disassembly, record the governor performance and the turned-down amounts of the adjustment points. During disassembly, put all parts neatly and orderly on the work bench to facilitate fast reassembly and adjustments.

If drastic maladjustments or malfunctioning parts are detected, the causes of the problems can be located by comparing the pre-and post-disassembly adjustment values.

Prior to disassembly of the RSV mechanical governor, thoroughly remove the dust and other foreign substances from the external surfaces and remove the lubricant from the cam and governor chambers of the injection pump. Be sure to use special tools for disassembly and avoid application of undue forces and rough operations.

(1) Disassembly

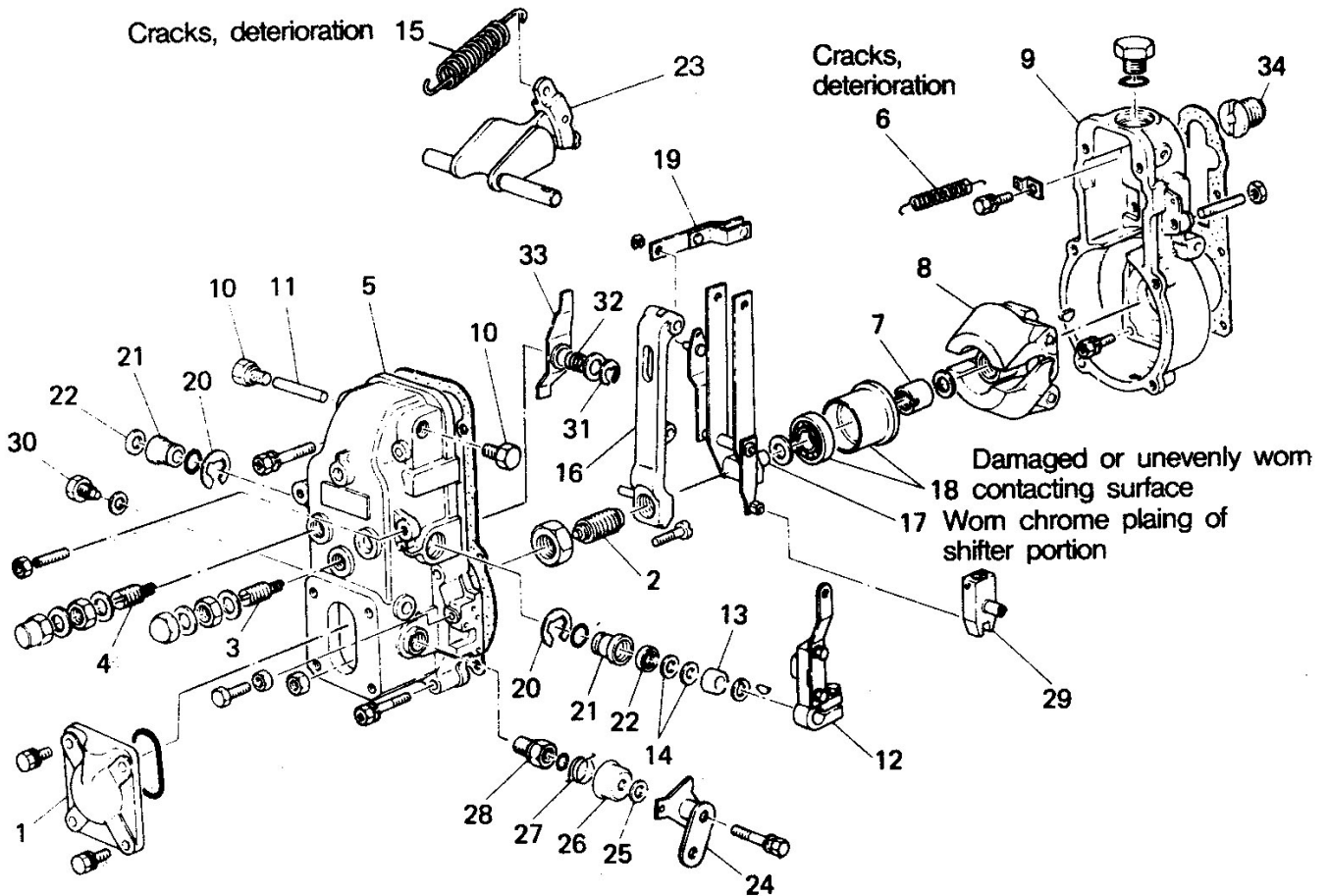

- | | | |
|----------------------------|-------------------------|-------------------------|
| 1 Closing cover | 13 Collar | 25 Shim |
| 2 Ungleich spring capsule | 14 Shim | 26 Spring cap. |
| 3 Idling subspring capsule | 15 Governor spring | 27 Return spring |
| 4 Torque spring capsule | 16 Tension lever | 28 Bushing |
| 5 Governor cover | 17 Guide lever assembly | 29 Sliding lever |
| 6 Start spring | 18 Sleeve | 30 Bolt |
| 7 Round nut | 19 Floating lever link | 31 Snap ring |
| 8 Flyweight | 20 Snap ring | 32 Spring |
| 9 Governor housing | 21 Bushing | 33 Torque control lever |
| 10 Plug | 22 Oil seal | 34 Adapter |
| 11 Tension lever shaft | 23 Swivel lever | |
| 12 Control lever | 24 Stop lever | |

(a) Removal of ungleich spring assembly

Using special tool(Socket Wrench), loosen the nut tightening the ungleich spring assembly to the tension lever, and remove the ungleich spring capsule.

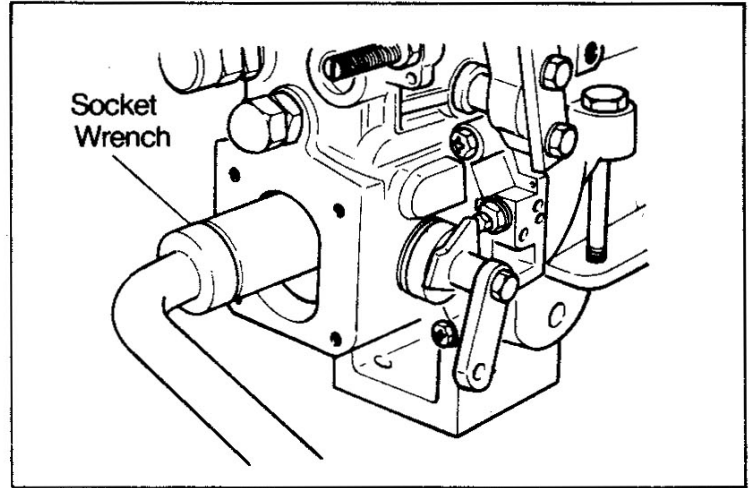

(b) Removal of flyweight

Using special tool(Special Wrench), remove the round nut tightening the flyweight. At this time, hold the drive side to prevent it from turning.

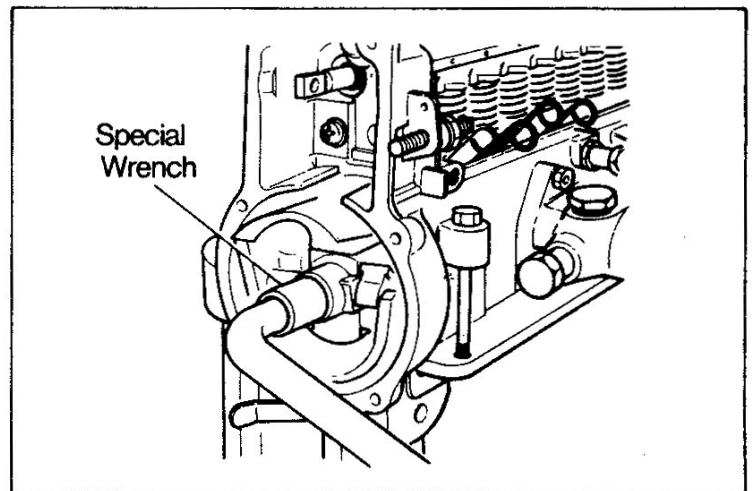

Thread special tool(Extractor) into the flyweight.

After the bolt end has touched the camshaft, lightly strike the bolt head and turn down the bolt to remove the flyweight.

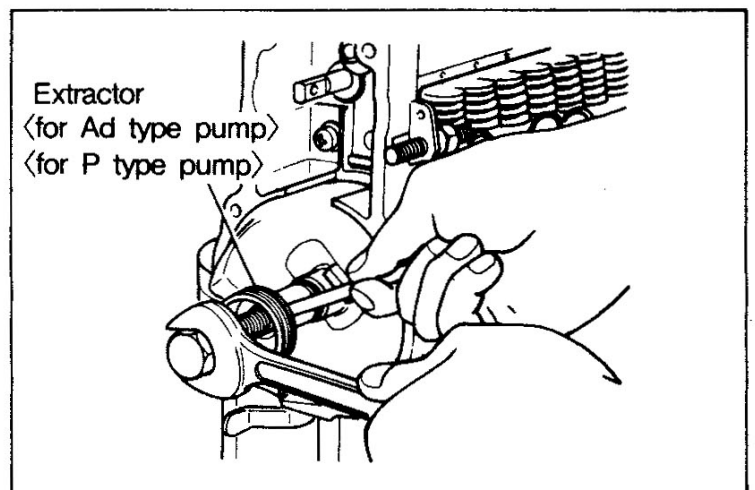

NOTE : Do not attempt disassembly to remove the swivel lever except when replacement of parts is necessary or when unsmooth operation is evident. In addition, disassembly of parts for the stop device and torque spring mechanism of the governor is not generally required.

(2) Inspection and Correction

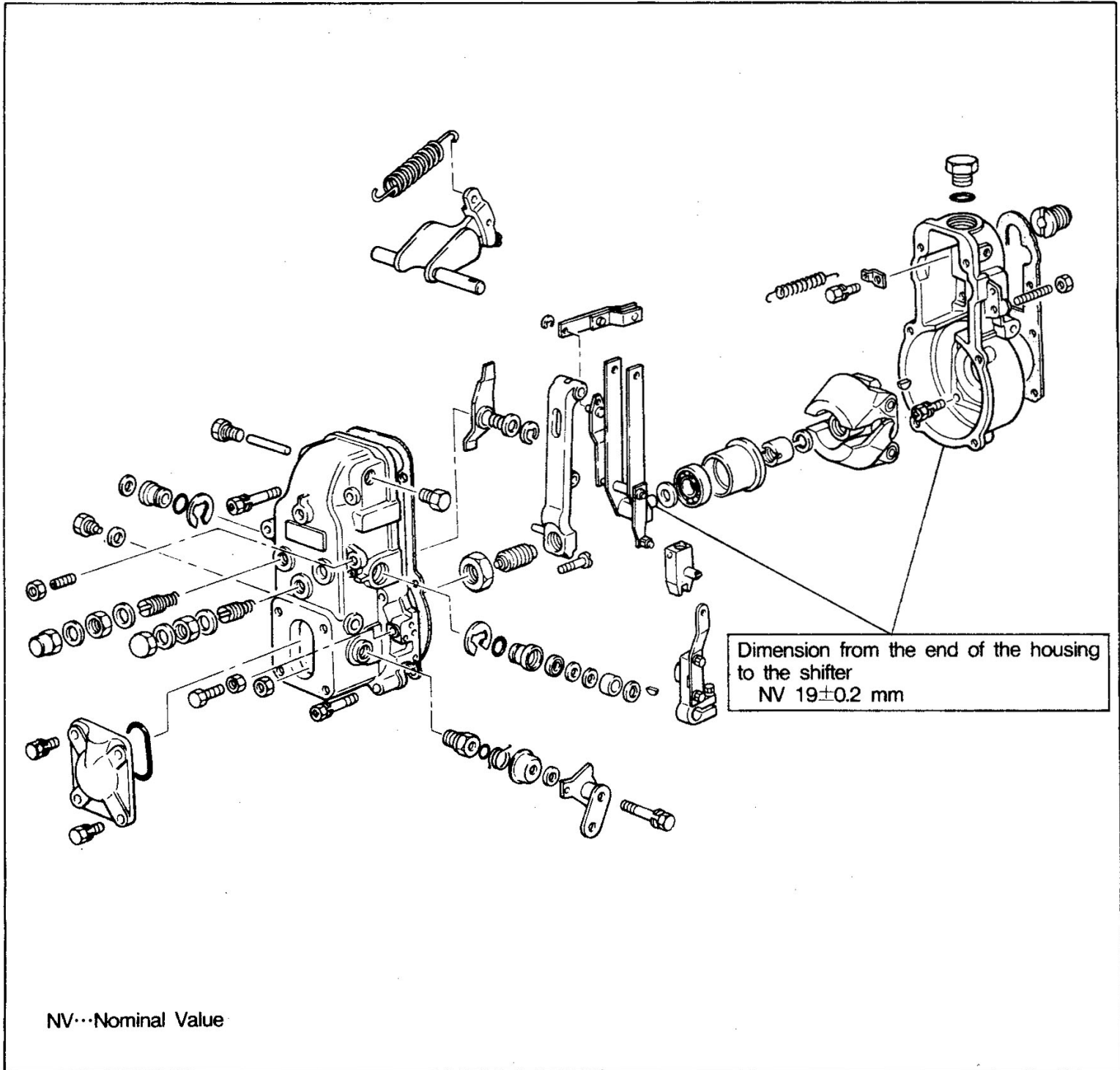

Replacement of sleeve or guide lever assembly

- Remove the bearing from inside the shifter, using a press.
- Using a press, remove the shifter of the guide lever assembly from the bearing.

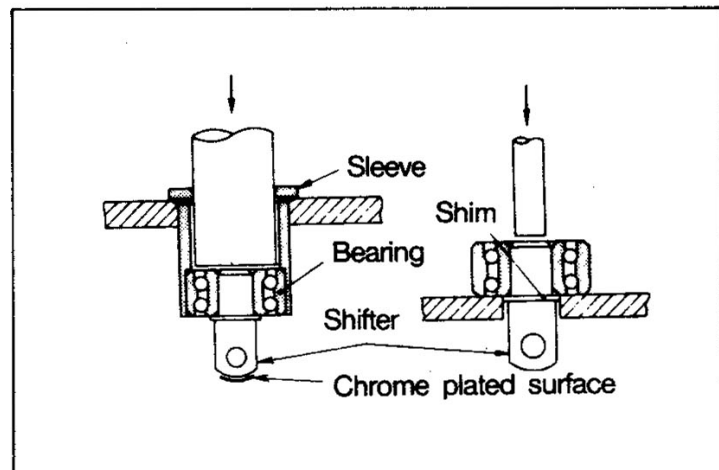

- (c) Install the bearing in the sleeve.
- (d) Then install the shifter of the guide lever assembly in the bearing.
- (e) Check to ensure that the sleeve rotates smoothly.

NOTE : 1. Do not replace the shim, as it has a thickness determined by adjustment of Item (f).

- 2. During the removal and installation operations, use care not to damage the chrome plated surface of the shifter.

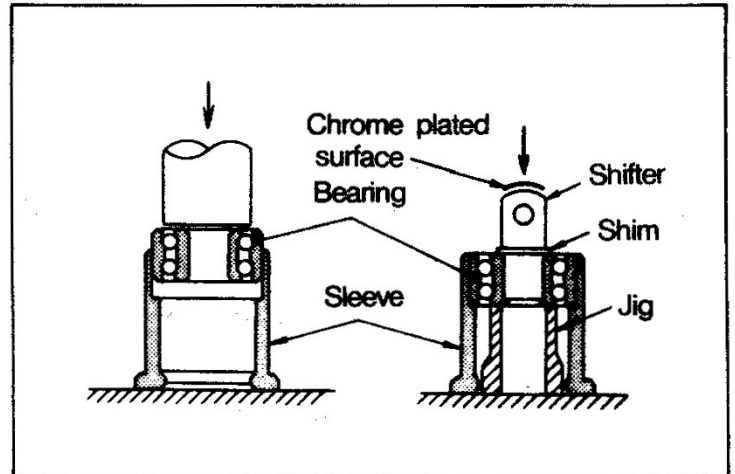

- (f) When the shim has to be replaced, assemble all related parts correctly and select the right shim thickness to make sure that the dimension from the end of the housing to the shifter complies with the specified value.

Shim thickness(4 types)

0.2, 0.3, 0.4, 1.0mm

NOTE : Measure the assembly dimension without lifting the flyweights.

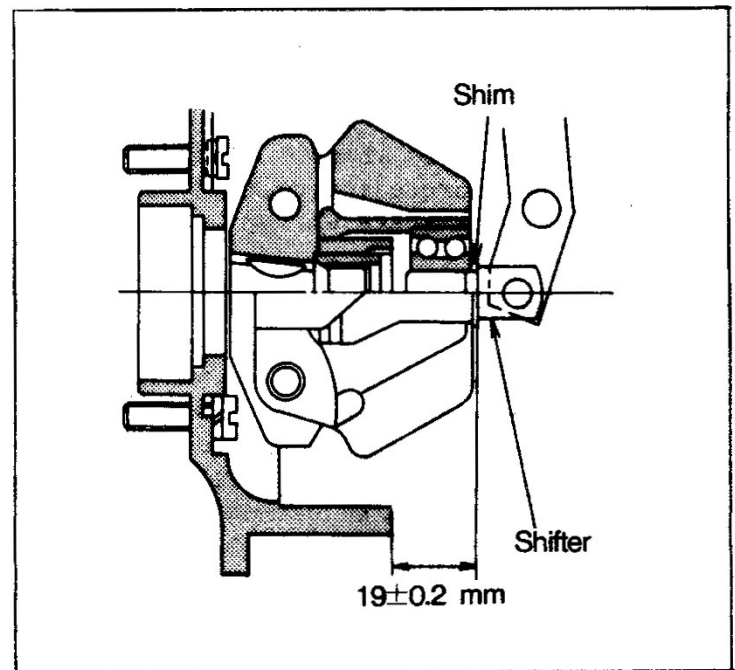

Prior to disassembly of the RFD mechanical governor, thoroughly remove the dust and other foreign substances from the external surfaces and remove the lubricant from the cam and governor chambers of the injection pump. Be sure to use special tools for disassembly and avoid application of undue forces and rough operations.

(1) Disassembly

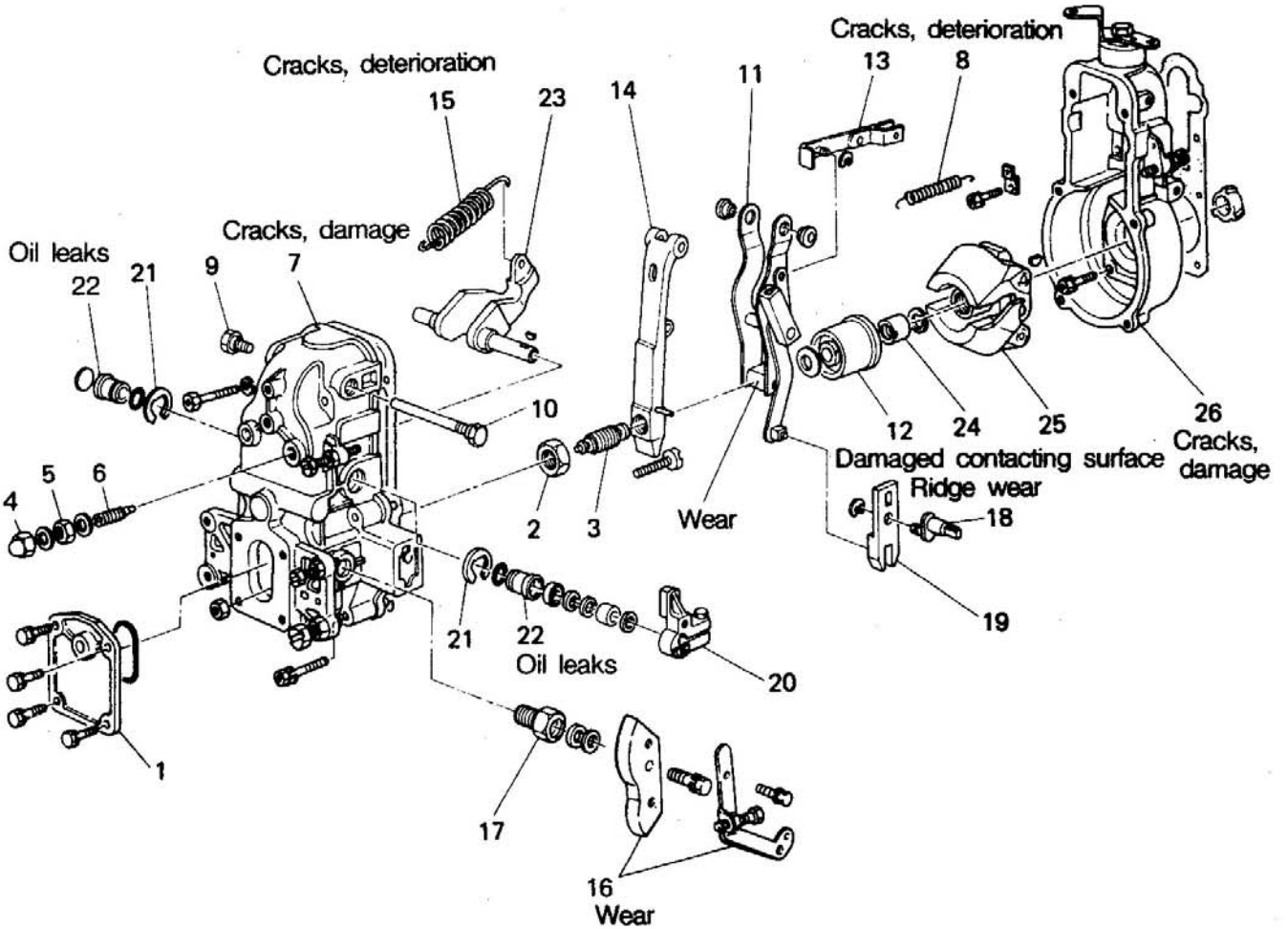

- | | | |
|--------------------------|-------------------------|------------------------|
| 1 Governor cover | 10 Thension lever shaft | 19 Sliding lever |
| 2 Lock nut | 11 Guide lever assembly | 20 Speed control lever |
| 3 Idling spring assembly | 12 Sleeve | 21 Snap ring |
| 4 Cap nut | 13 Floating lever link | 22 Bushing |
| 5 Lock nut | 14 Tension lever | 23 Swivel lever |
| 6 Damper spring | 15 Governor spring | 24 Round nut |
| 7 Governor cover | 16 Load control lever | 25 Flyweight |
| 8 Start spring | 17 Bushing | 26 Governor housing |
| 9 Tension lever plug | 18 Lever shaft | |

- (a) Install special tool(Fitting Plate) in special tool(Universal Vice).

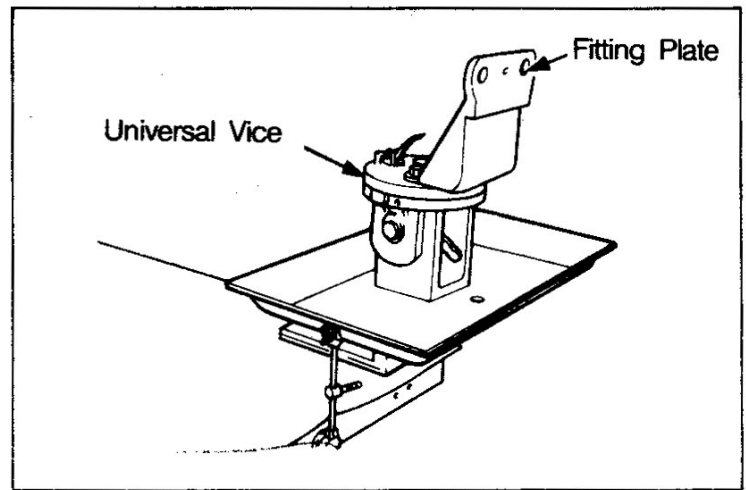

- (b) Remove the pipe joint bolt and overflow valve from the fuel inlet of the injection pump. Utilizing the threaded hole, install special tool(Plate).

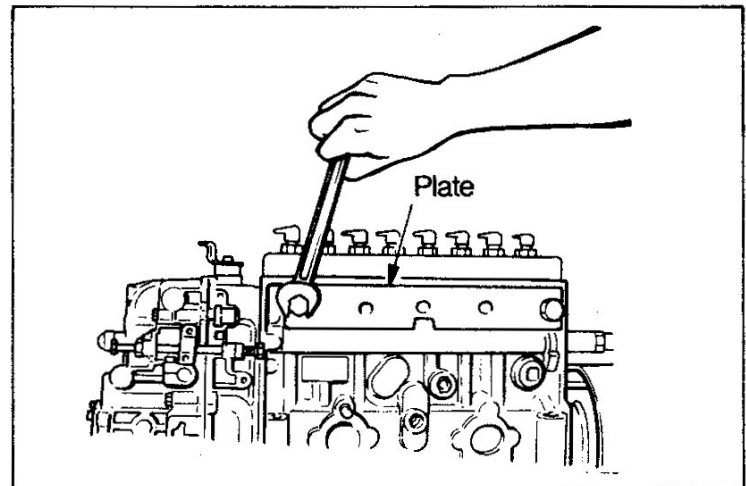

- (c) Install the injection pump in special tool(Universal Vice).

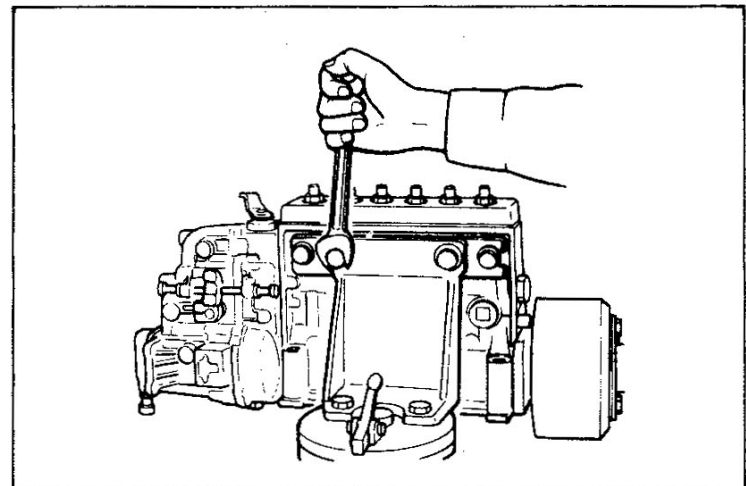

- (d) Remove the cover 1 and remove the lock nut 2 with special tools(Socket Wrench and Handle).

Furthermore, remove the idle spring capsule 3.

NOTE : Check the speed setting lever. If there is nothing wrong, do not disassemble it.

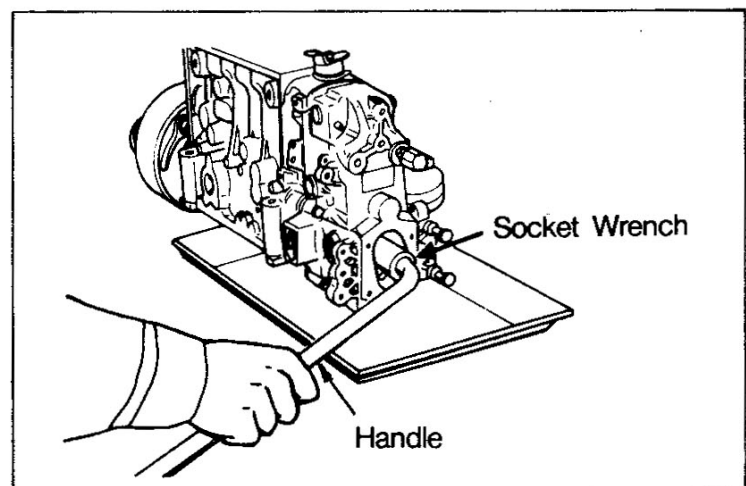

- (e) Remove the flyweight by the following procedure.

Using special tool (Special Wrench), remove the round nut 24 of the flyweight.

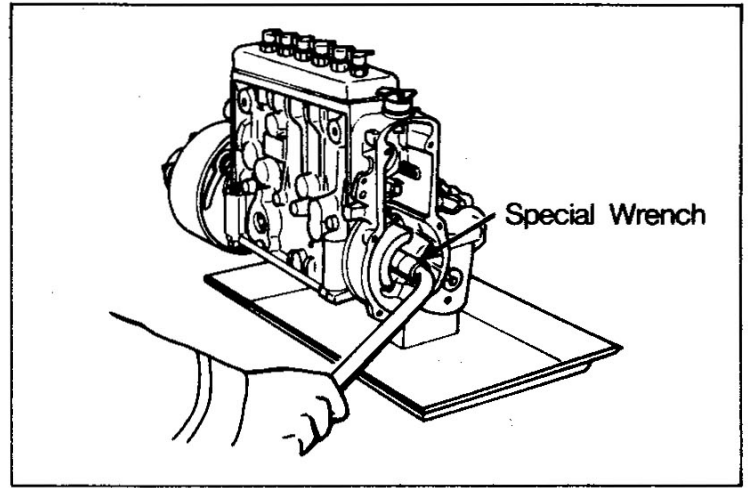

Using special tool (Extractor), remove the flyweight 25.

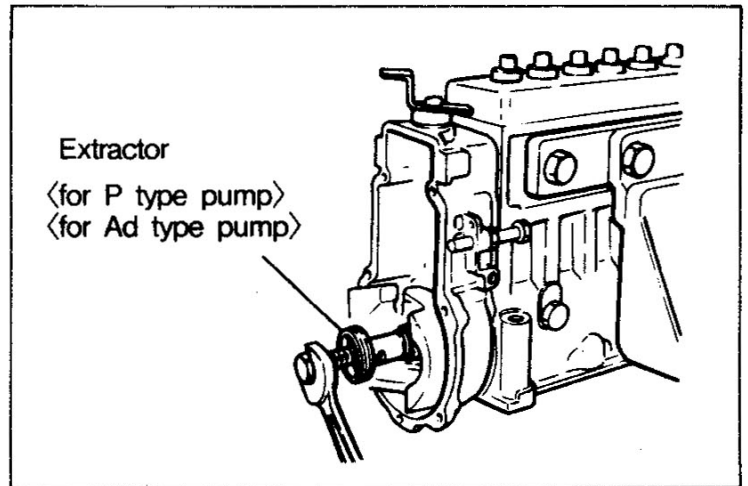

- (f) Remove the governor housing 26 by the following procedure.

Using special tool (Tappet Holder or Tappet Pin), disconnect the tappet from the camshaft.

Then remove the governor housing tightening bolts, and remove the governor housing, while striking with a plastic hammer, etc.

NOTE : Do not remove the stop lever assembly on the top of the governor housing from the governor housing.

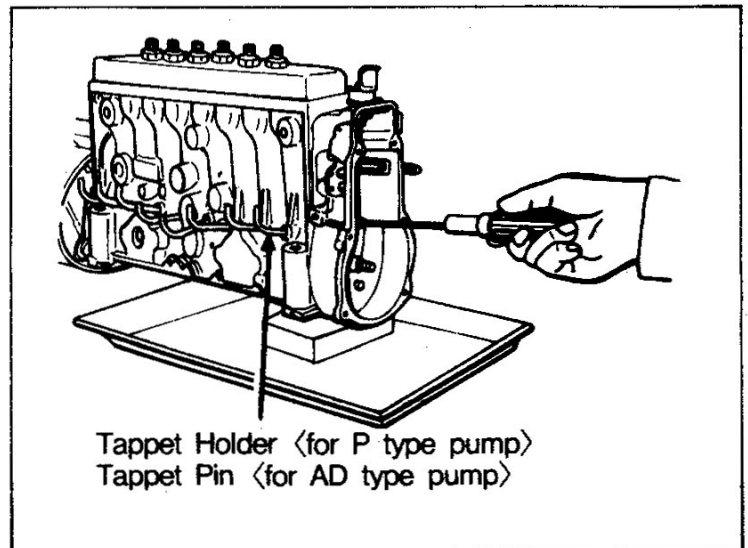

(2) Inspection and Correction

(a) Replacement of sleeve or guide lever assembly

To disassemble the shifter and sleeve, remove the snap ring in the sleeve, and the shifter and sleeve can be separated.

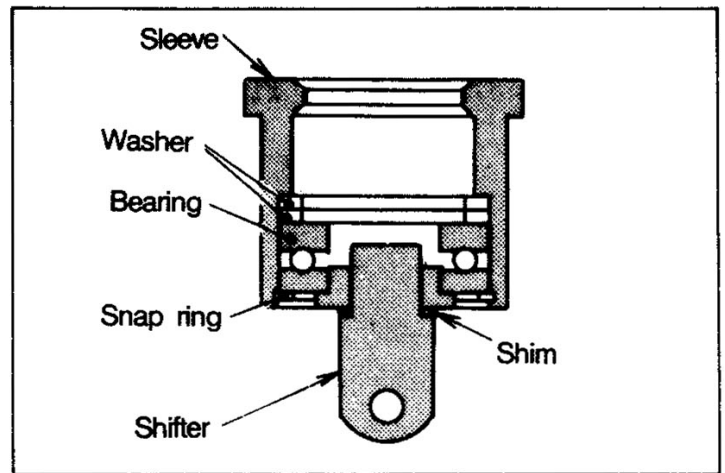

Use a press to remove the shifter and bushing.

NOTE : When the shifter and bushing are installed, use care not to damage the chrome plated surface of the shifter.

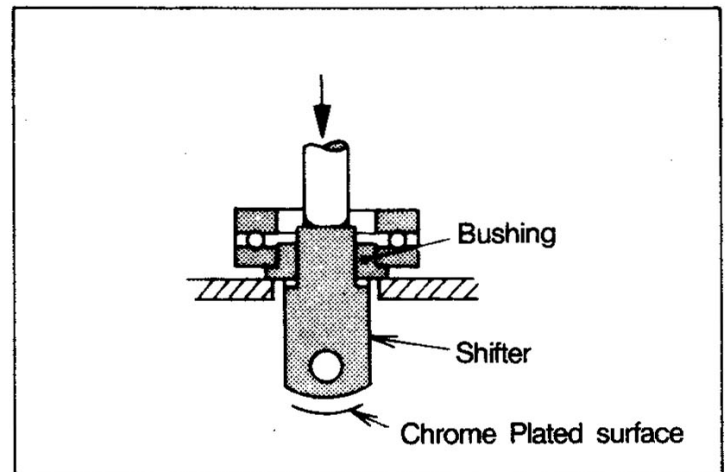

(b) Assembly dimension of shifter

When the shifter and sleeve are assembled, be sure not to change the adjusting shim, as the assembly dimension of the shifter has been adjusted by the shim.

If readjustment is necessary, assemble all related parts correctly and select the right shim thickness to make sure that the dimension from the housing end to the shifter complies with the specified value.

Shim thickness(4 types)

0.2, 0.3, 0.4, 1.0mm

NOTE : Measure the assembly dimension with all flyweights lifted.

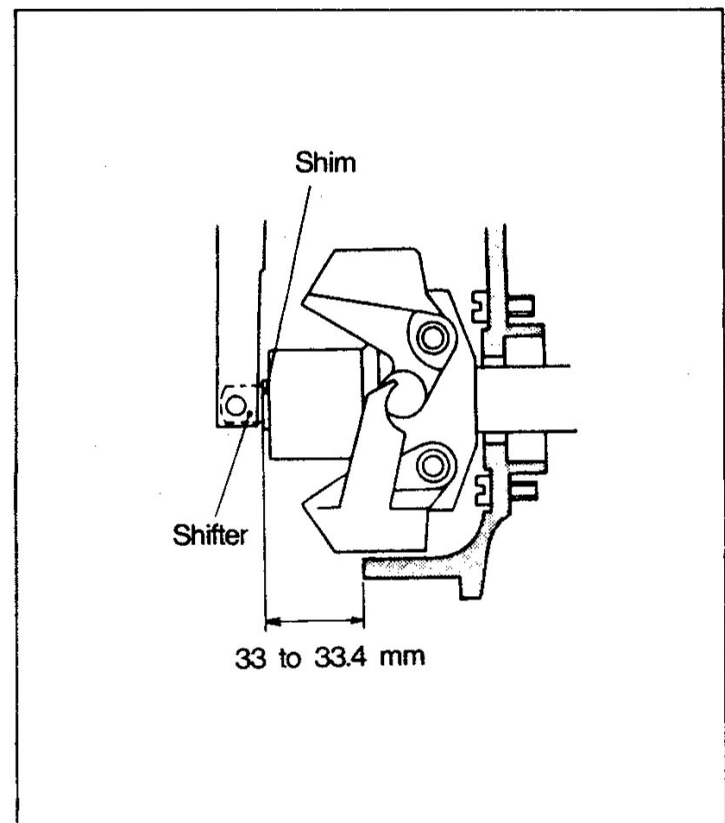

(3) Reassembly

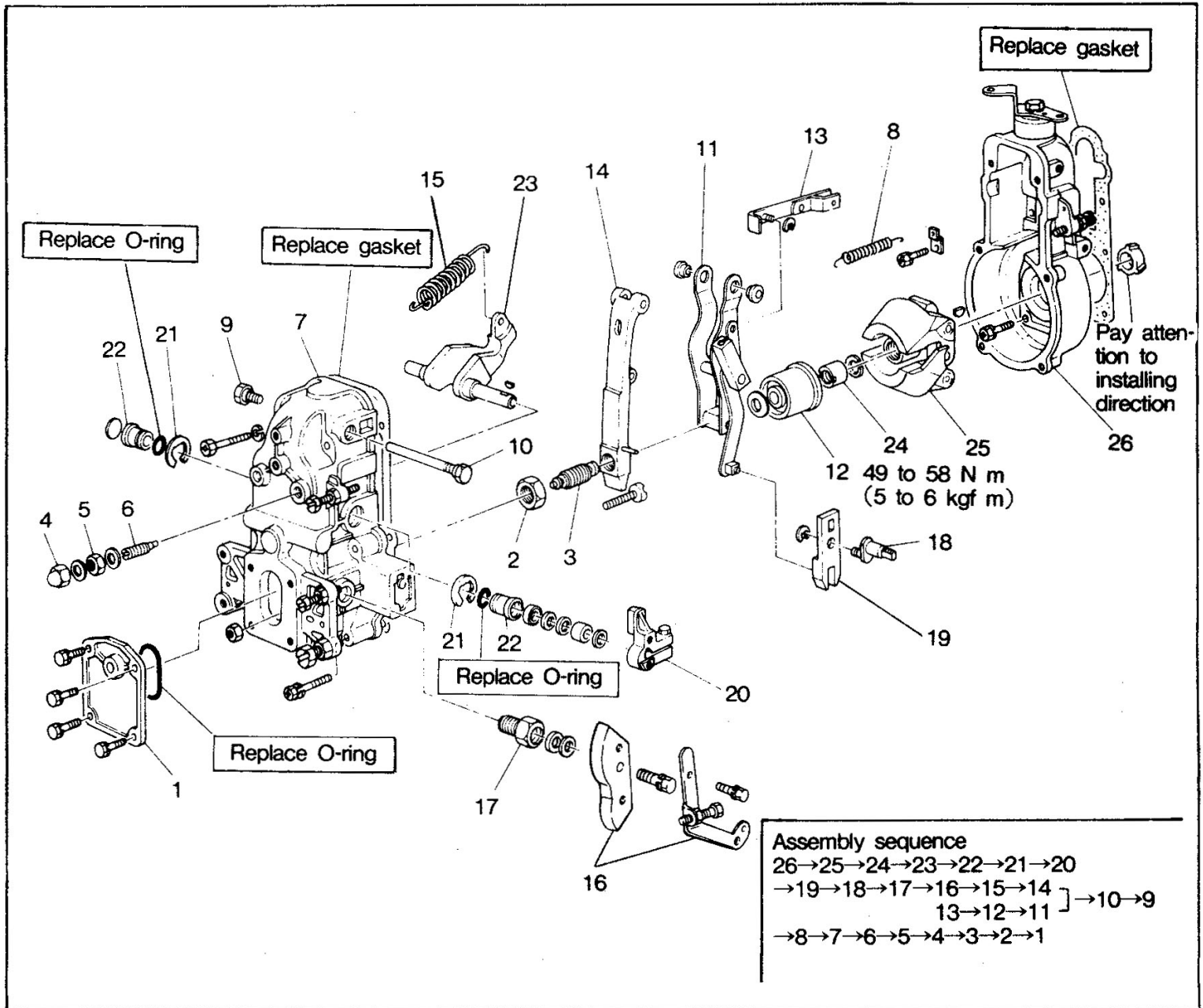

(a) Install the governor housing 26. After installation, remove the special tool (Tappet Holder or Tappet Pin).

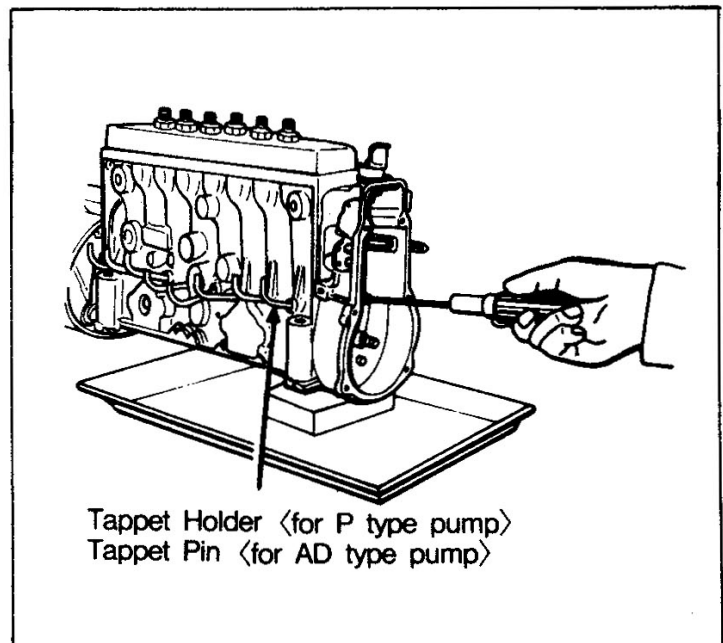

- (b) Install the flyweight 25 and tighten the round nut 24 to the specified torque with special tool(Special Wrench) and torque wrench.

NOTE : Use care not to forget to install the bushings on both sides of the guide lever assembly.

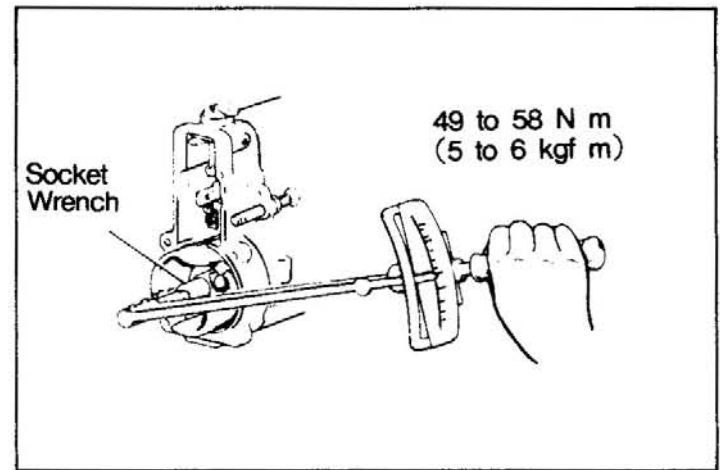

11-1-5 Feed Pump

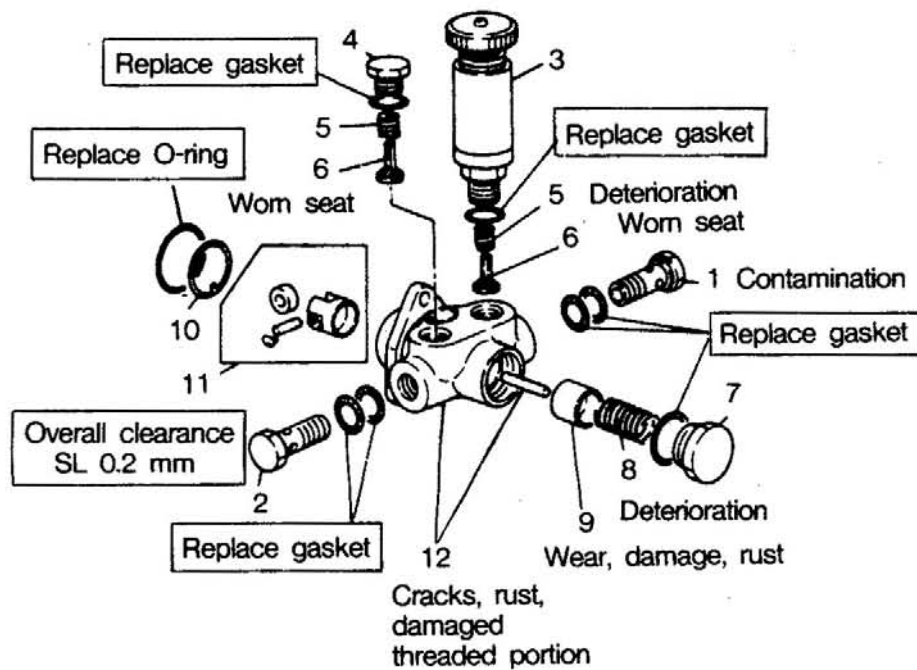

- | | |
|--|----------------------|
| 1 Eye bolt(suction side : with gauze filter) | 7 Plug |
| 2 Eye bolt(delivery side) | 8 Piston spring |
| 3 Priming pump | 9 Piston |
| 4 Check valve plug | 10 Snap ring |
| 5 Check valve spring | 11 Tappet |
| 6 Check valve | 12 Feed pump housing |

11-1-6 SA Type Automatic Timer

In servicing the SA type automatic timer, use special tools.

(1) Disassembly

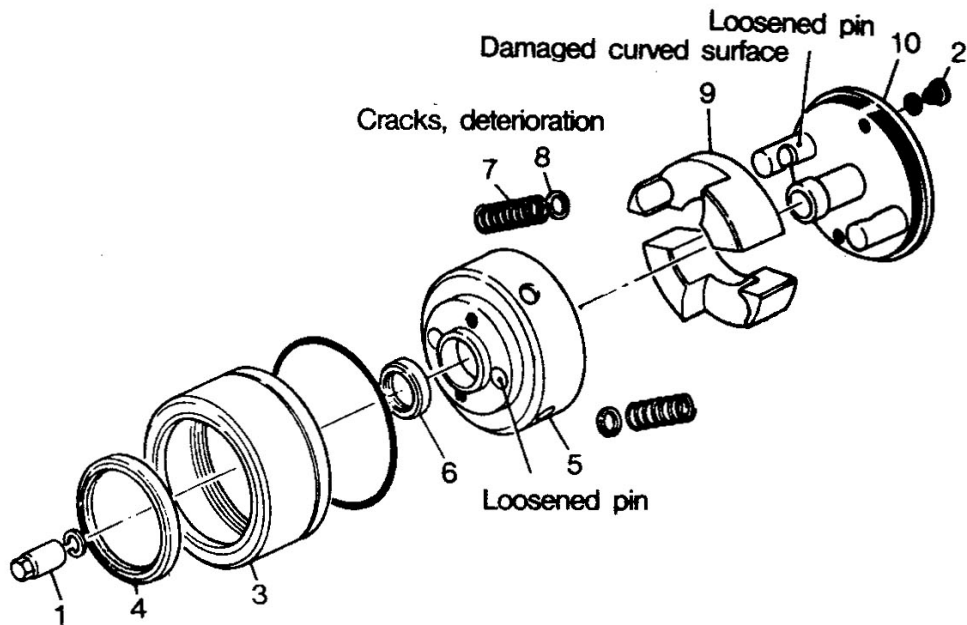

1 Round nut

2 Timer plug

3 Timer case

4 Oil seal

5 Flange

6 Oil seal

7 Spring

8 Shim

9 Flyweight

10 Holder

(a) Remove the coupling from the automatic timer.

(b) Mount special tool (Special Spanner) in the coupling mounting threaded hole to prevent turning, and remove the round nut 1.

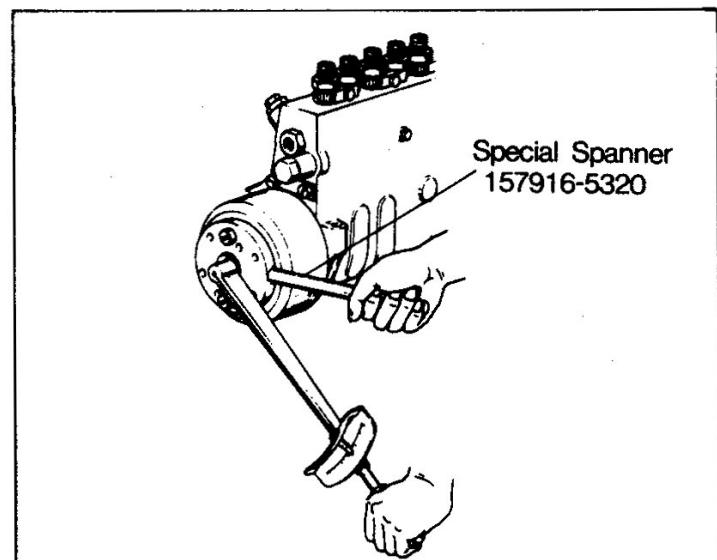

- (c) While holding the automatic timer with special tool(Special Spanner) to prevent it from turning, remove the automatic timer with special tool (Extractor).

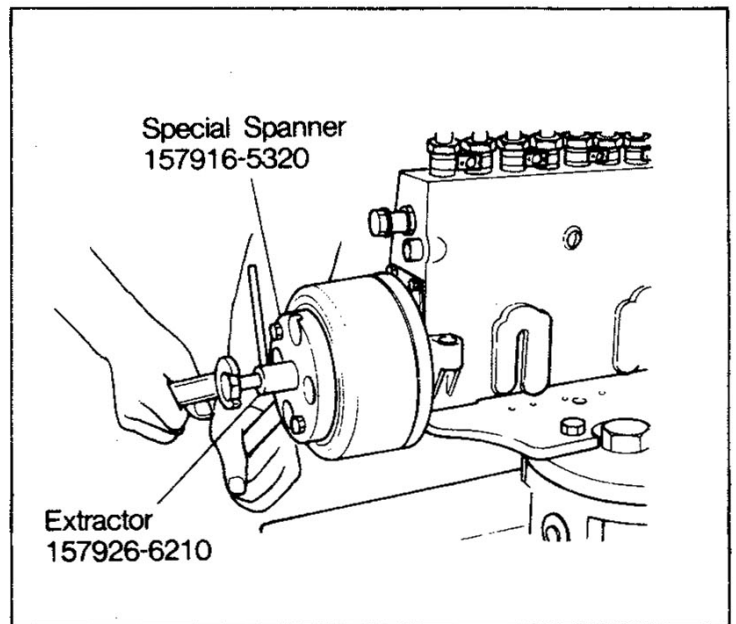

- (d) Mount special tools(Base and Guide Bolt) in the vice.

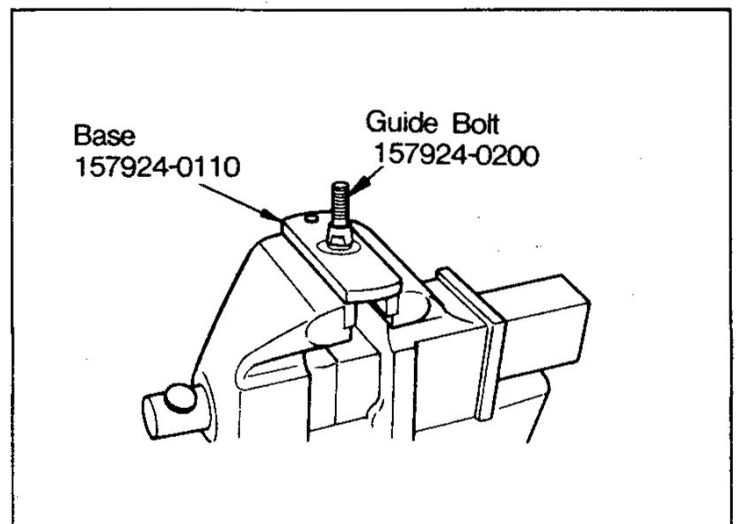

- (e) Remove the timer plug 2 and place the automatic timer on special tool (Base).

NOTE : Line up the hole in the timer plug with the pin of the base.

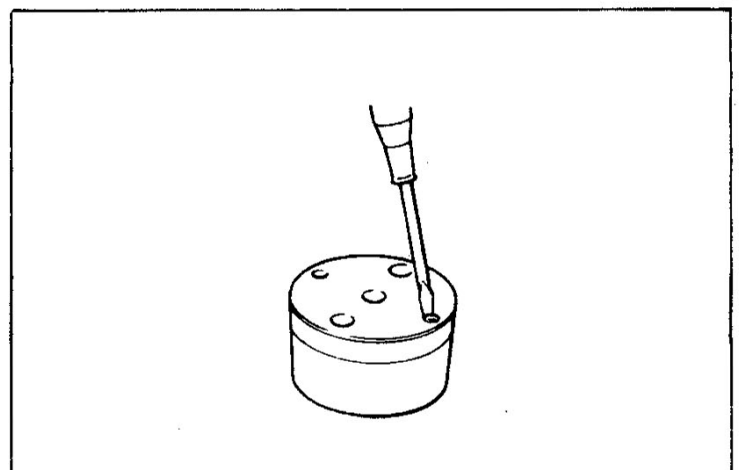

(f) Using special tool (Hand Spanner), remove the timer case 3 by turning clockwise.

Remove the oil seal 4 from the timer case.

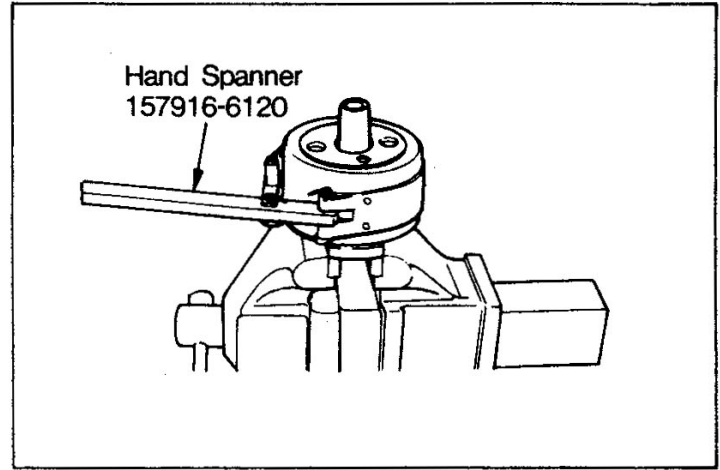

(2) Reassembly

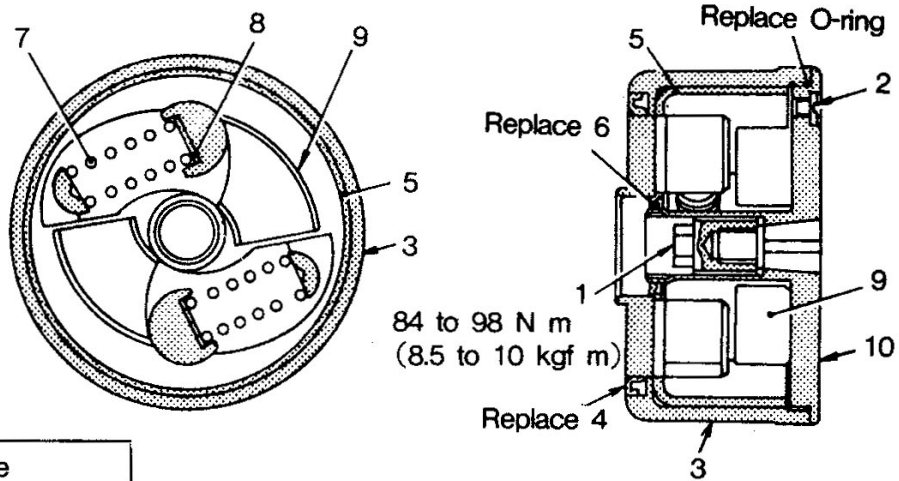

Assembly sequence

6→5 }
 10→9→8→7 } →2→1
 4→3 }

(a) Mount special tools (Base and Guide) in a vice.

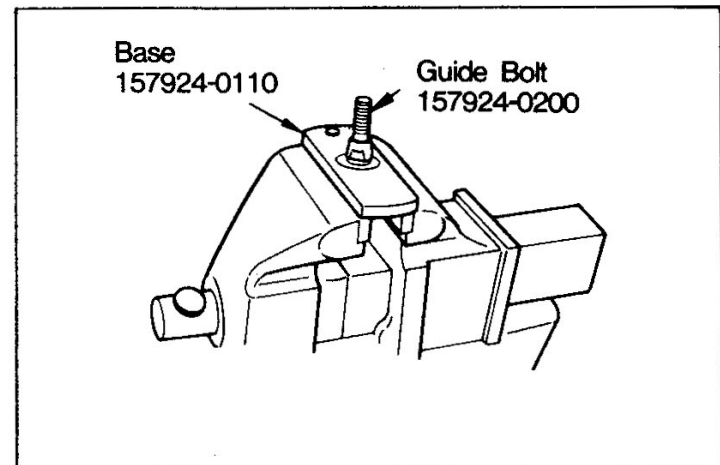

(b) Install the oil seal 6 in the flange.

- 1) Mount special tool(Block) to the base.
- 2) Put the flange so that its pins will fit in the holes in the block.
- 3) Apply NEJI LOCK to the oil seal installing hole in the flange.
- 4) Put the oil seal in the hole in the flange.

Install the oil seal by turning down special tool(Thrust Bushing) with special tool(Guide Bushing) in between.

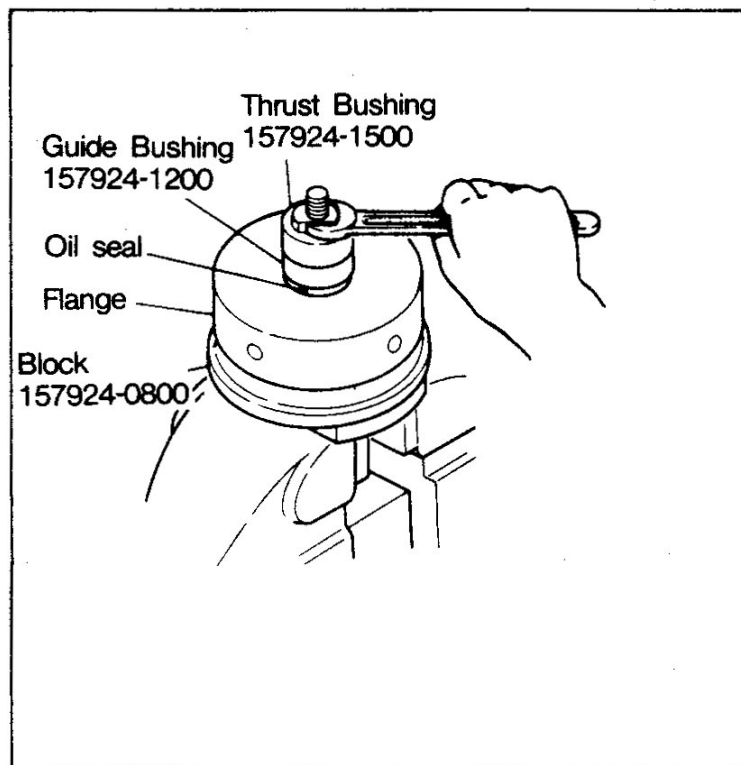

(c) Install the oil seal 4 in the timer case.

- 1) Mount special tools(Block and Guide) to the base.
- 2) Put the timer case on the guide.
- 3) Apply NEJI LOCK to the oil seal installing hole in the timer case.
- 4) Put the oil seal in the hole in the timer case. Install the oil seal by turning down special tool(Thrust Bushing) with special tool (Guide Bushing) in between.

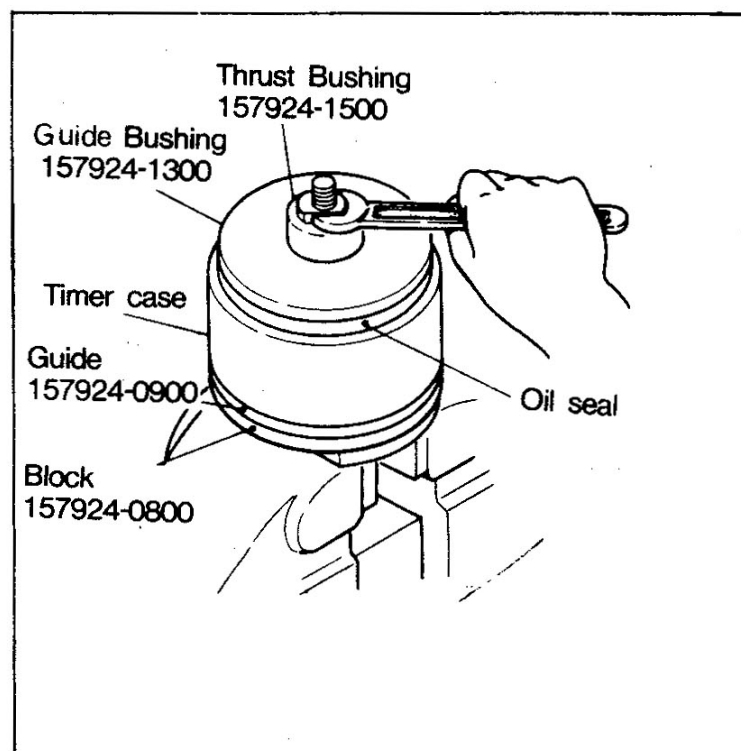

(d) Place the holder 10 on special tool (Base).

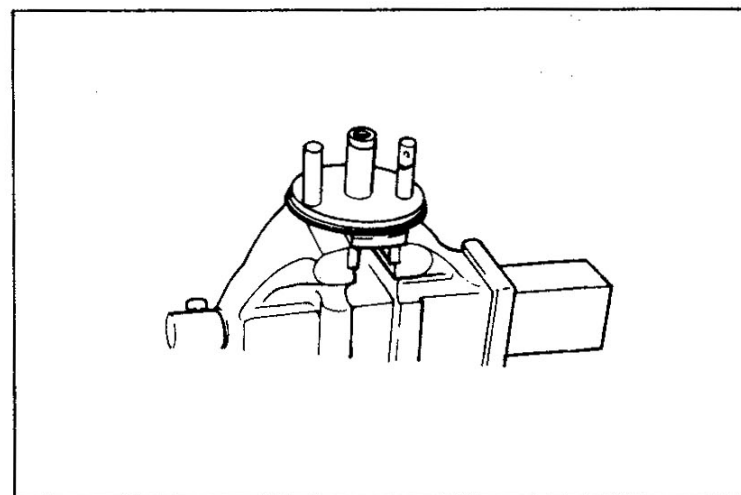

- (e) After placing special tool(Support) on the flyweight, install the shim 8 and spring 7.

Thread special tool(Guide) onto the guide bolt.

NOTE : Select the proper shim thickness suitable for the advance angle of the automatic timer.

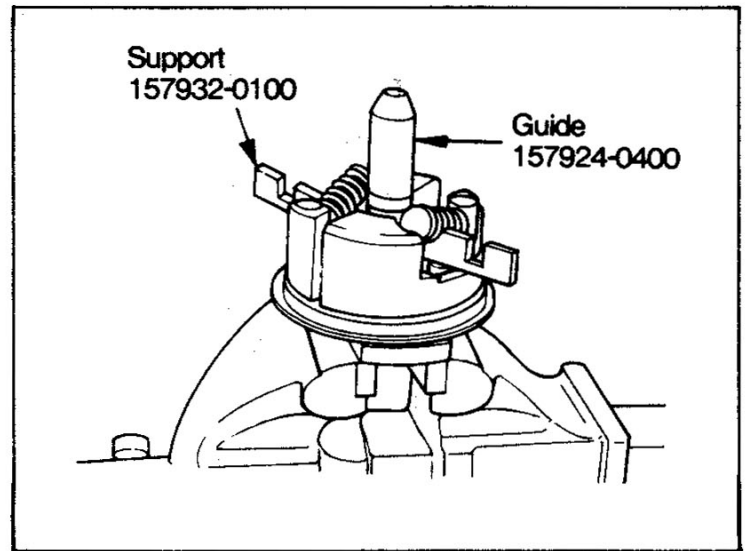

- (f) Put the flange 5 so that the pin of the flange will touch one end of the spring.

Mount special tool(Special Spanner) to the coupling mounting hole of the flange.

Furthermore, mount special tool(Thrust Bushing) with a bolt.

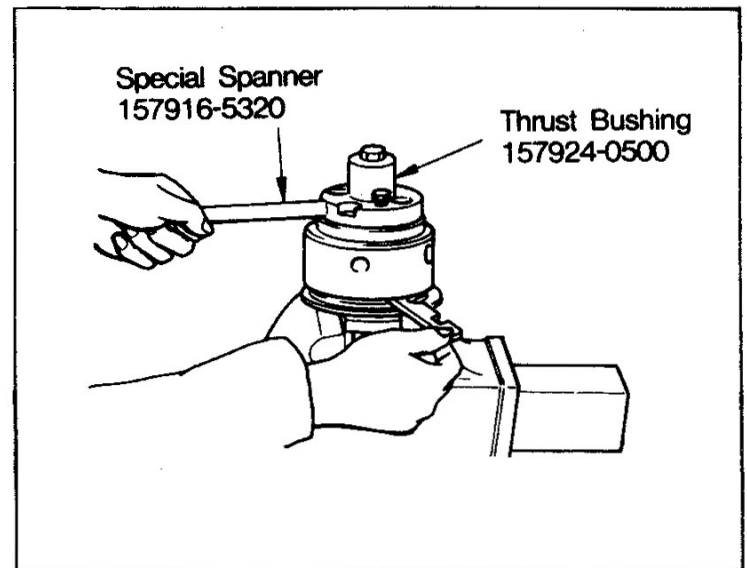

- (g) After placing special tool(Oil Seal Guide) on the flange, insert the timer case 3.

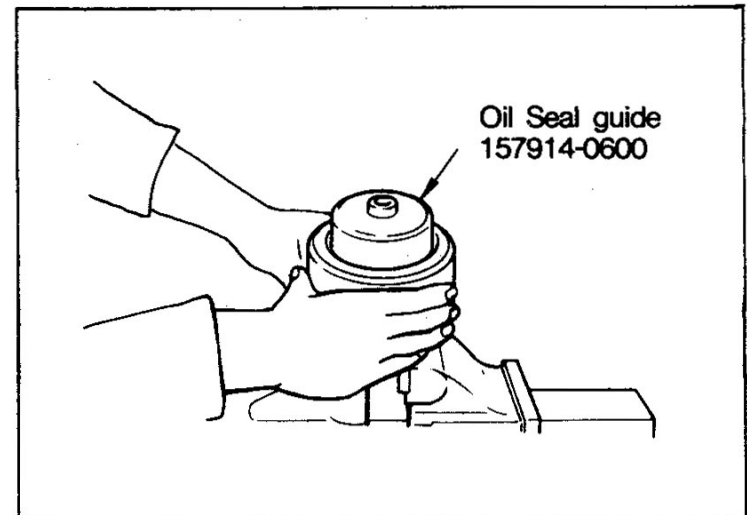

- (h) After the oil seal guide has been removed, turn down the timer case onto the holder with special tool (Band Spanner), and punch it.

NOTE : Turn down the timer case until the injection start timing lines inscribed on the timer case and flange are in alignment.

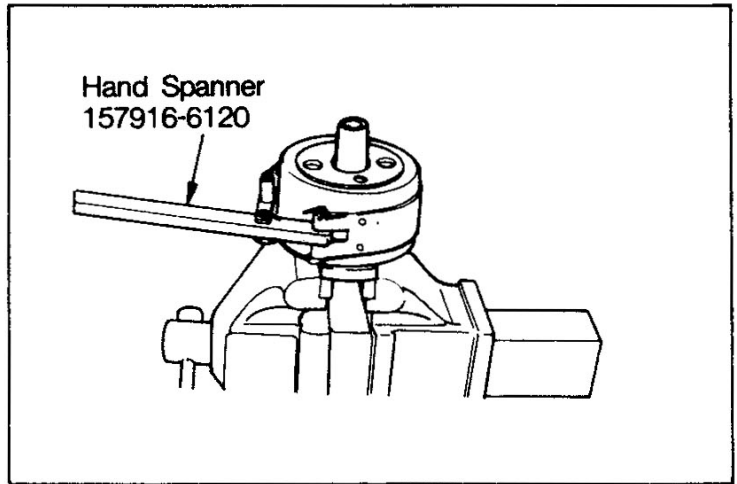

- (i) Inject approx. 150g of automatic timer grease from the timer plug hole.

After grease has been injected, tighten the timer plug 2.

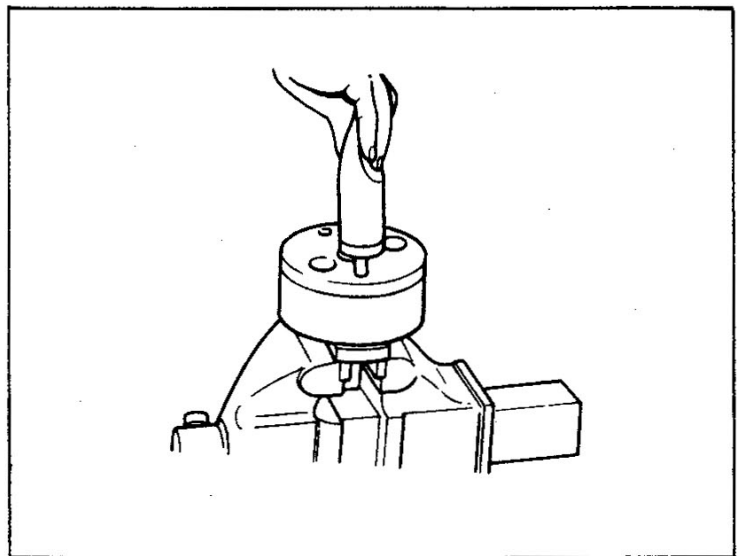

- (j) After the automatic timer has been installed on the camshaft, fit special tool (Special Spanner) into the coupling mounting hole. While holding it to prevent turning, tighten the round nut 1 to the specified torque.

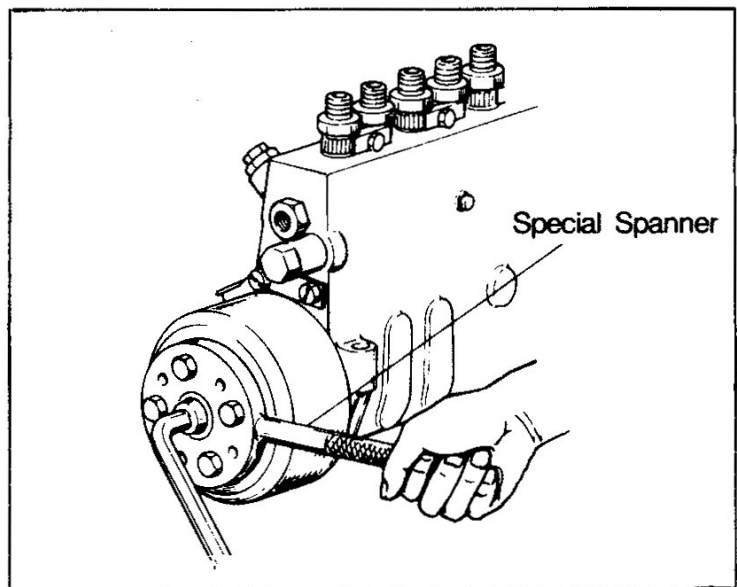

11-1-7 SP Type Automatic Timer

In servicing the SP type automatic timer, use special tools.

(1) Disassembly

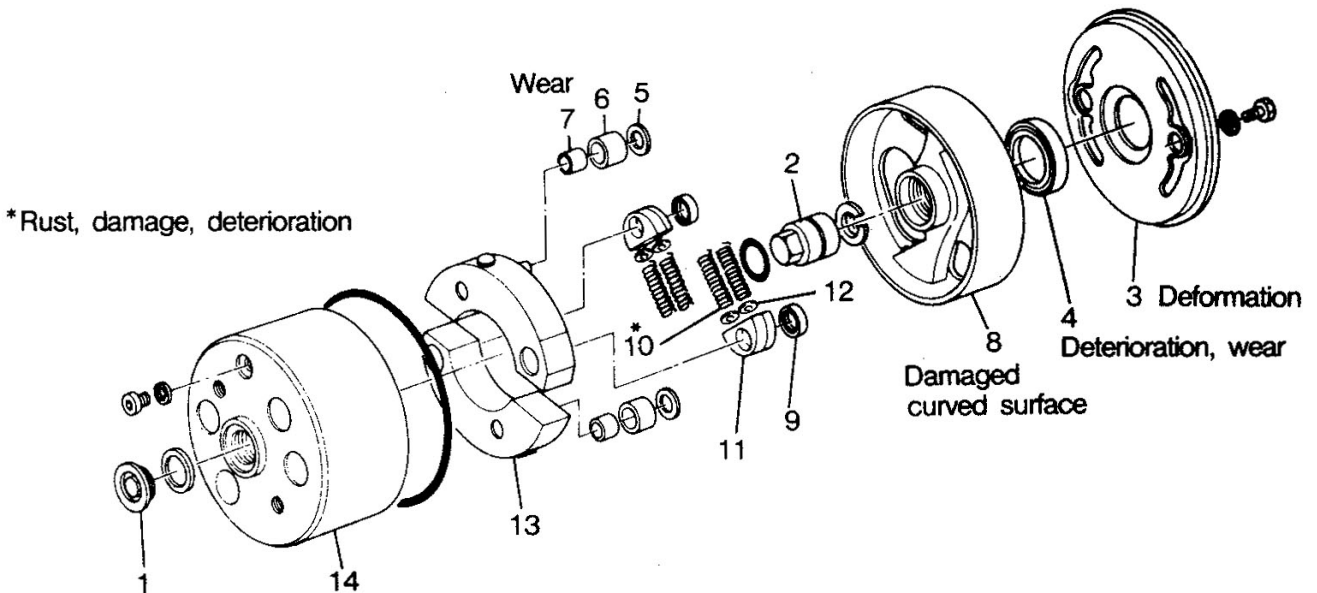

- | | |
|-------------|------------------|
| 1 Cap screw | 8 Flange |
| 2 Round nut | 9 Retainer |
| 3 Cover | 10 Timer spring |
| 4 Oil seal | 11 Spring seat |
| 5 Washer | 12 Shim |
| 6 Roller | 13 Flyweight |
| 7 Bushing | 14 Timer housing |

(a) Remove the coupling from the timer.

(b) Remove the cap screw 1 of the timer. While using special tool (Box Spanner), remove the round nut 2 with special tool (Box Wrench).

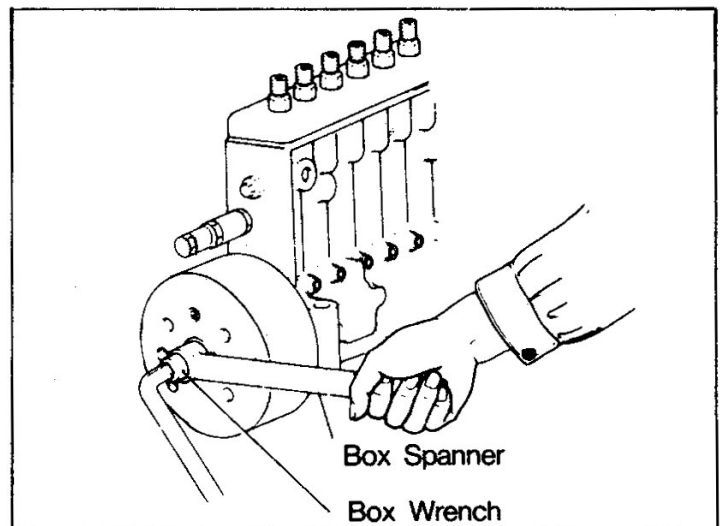

(c) Mount special tool(Special Spanner) by taking advantage of the coupling mounting thread. While holding it to prevent turning, remove the timer from the injection pump, using special tool(Extractor).

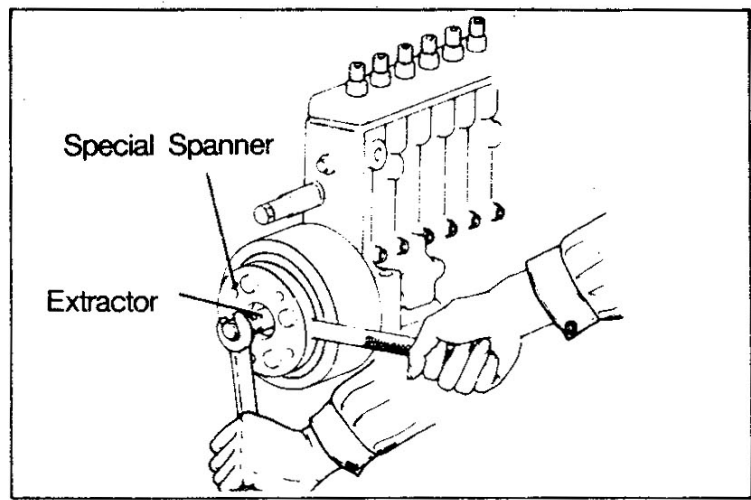

(d) Mount special tool(Base) in a vice.

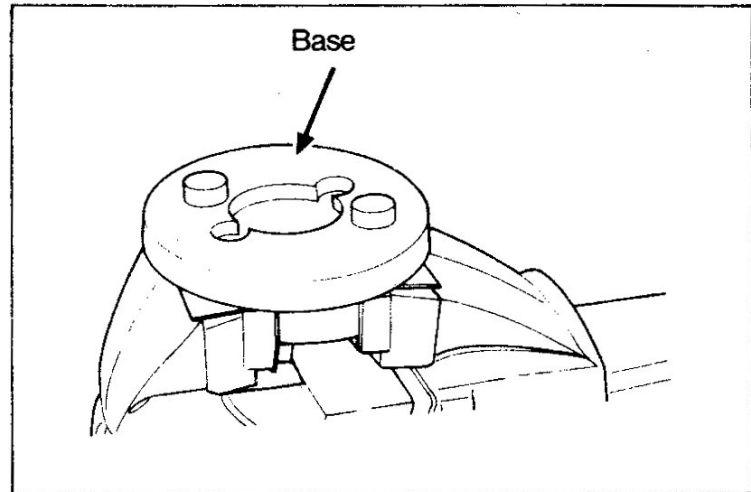

(e) Fix the timer to special tool(Base).

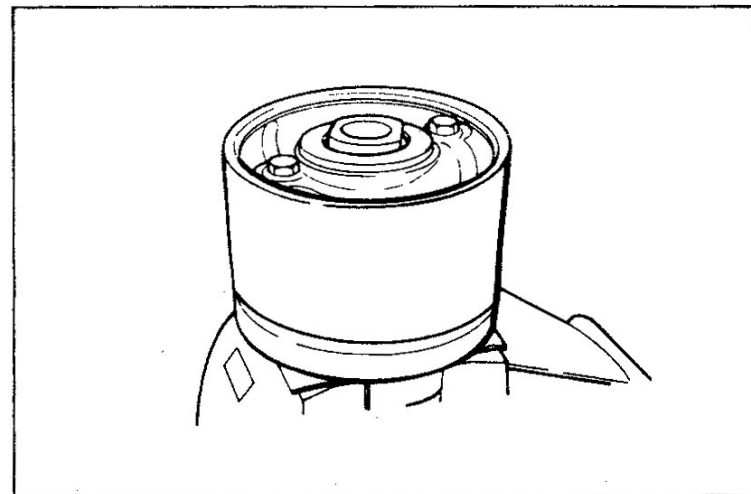

(f) Mount special tool(Special Spanner) to the flange. With the timer spring compressed, remove the washer 5, roller 6 and bushing 7.

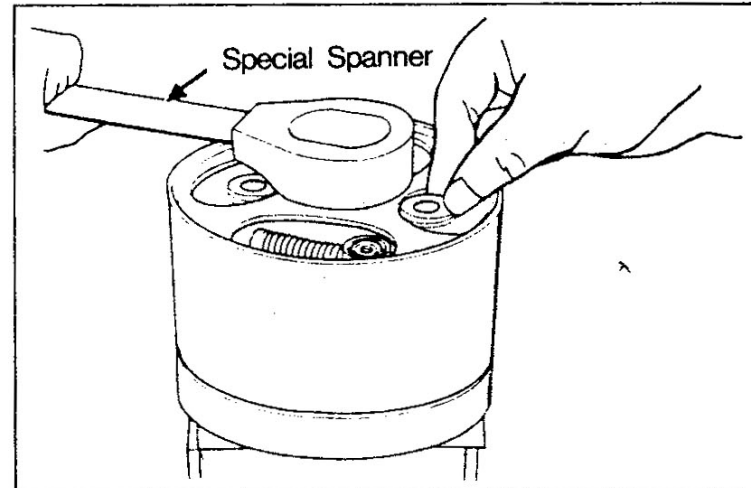

(2) Reassembly

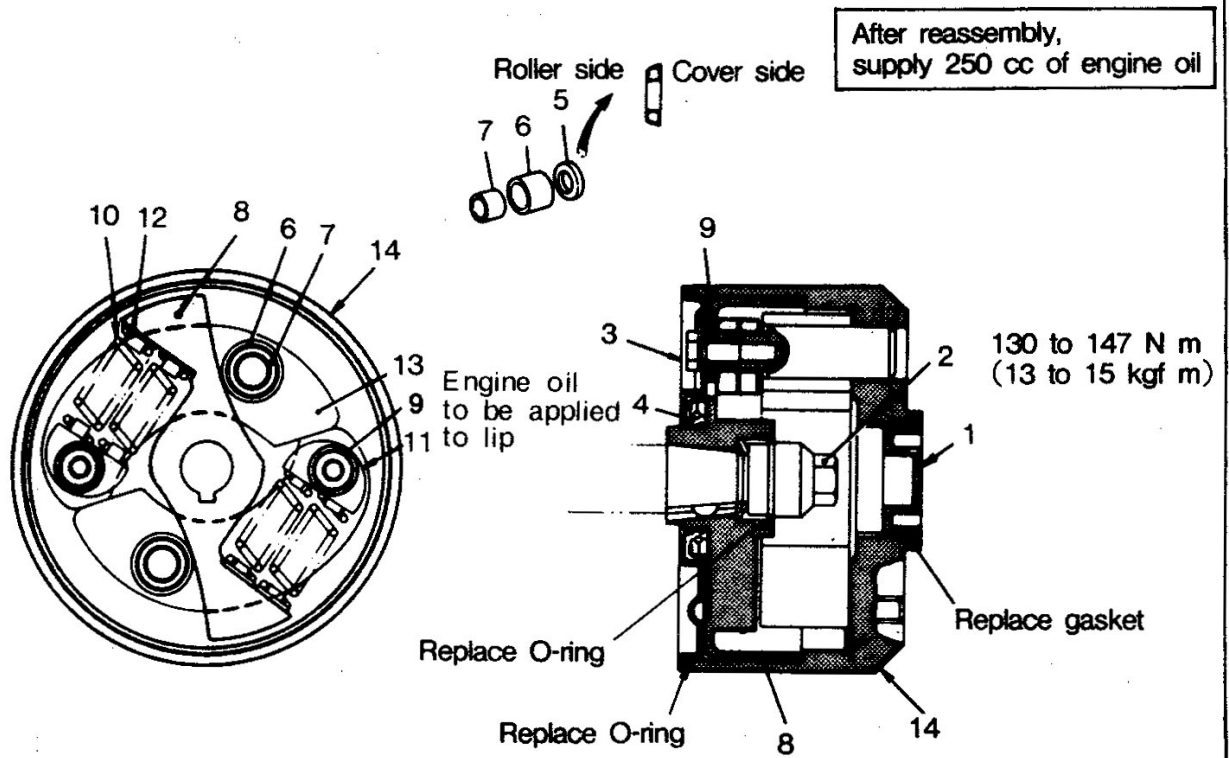

Reassembly sequence
 14→13→12→11→10→9
 →8→7→6→5→4→3→2→1

- (a) Mount special tool(Base) in a vice and secure the timer housing 14 to the base.

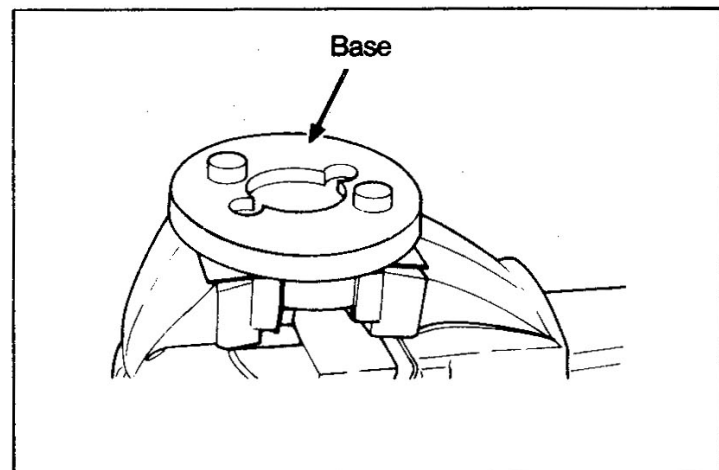

(b) Mount special tool(Special Spanner) to the flange. With the timer spring compressed, install the following parts.

7 Bushing

6 Roller

5 Washer

NOTE : When the washer is installed, direct it as shown.

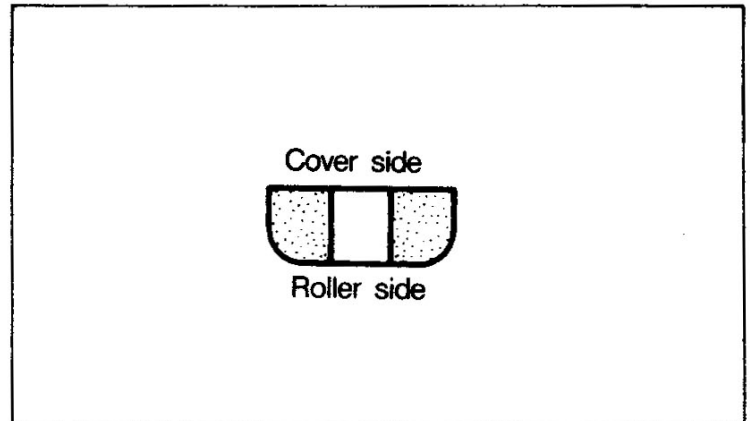
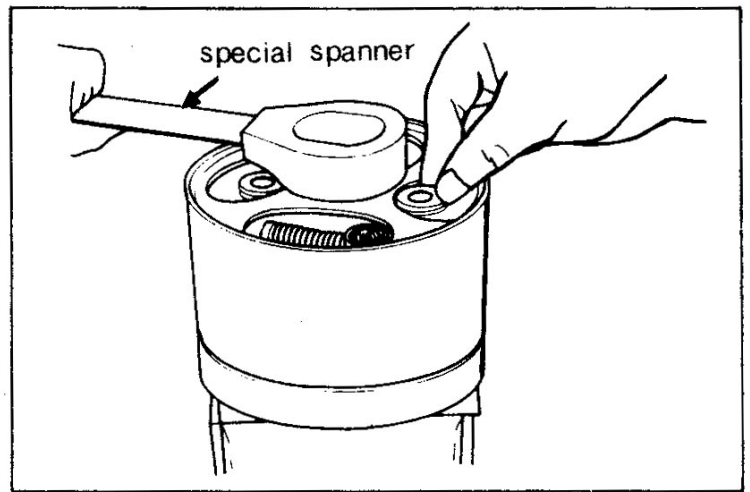

(c) Install the key to the injection pump camshaft and install the automatic timer. While using special tool (Special Spanner) to prevent turning, tighten the round nut to the specified torque.

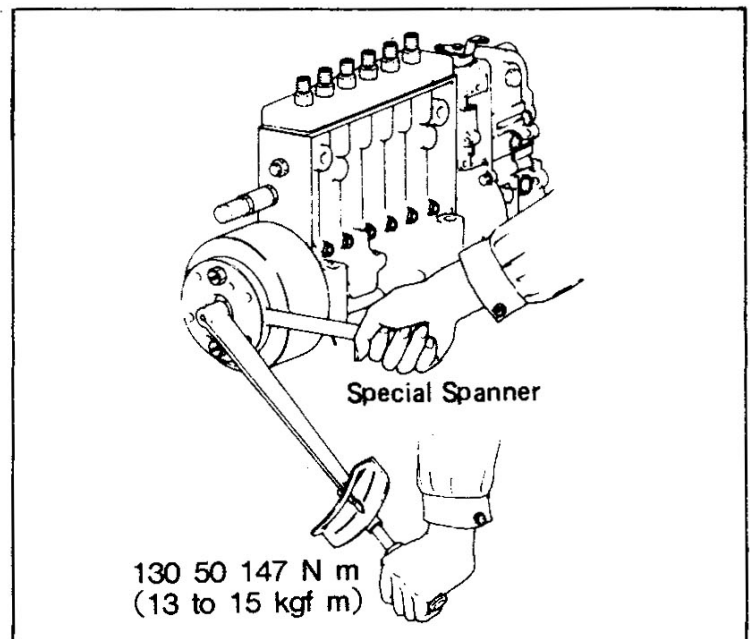

(d) Remove the plug at the rear end of the timer and supply 250 cc of engine oil.

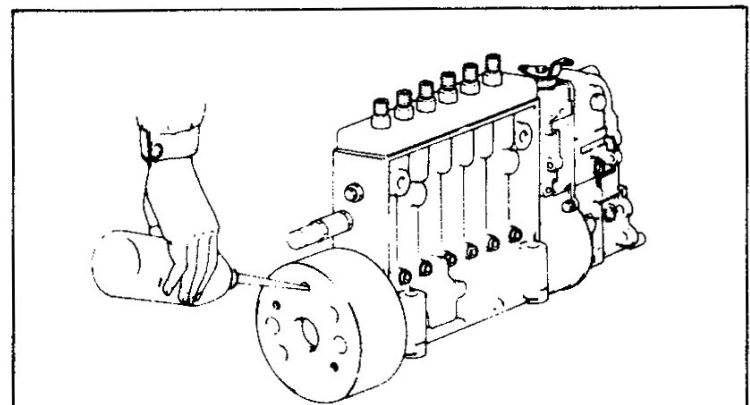

11-1-8 Test and Adjustment

(1) AD Type Injection Pump

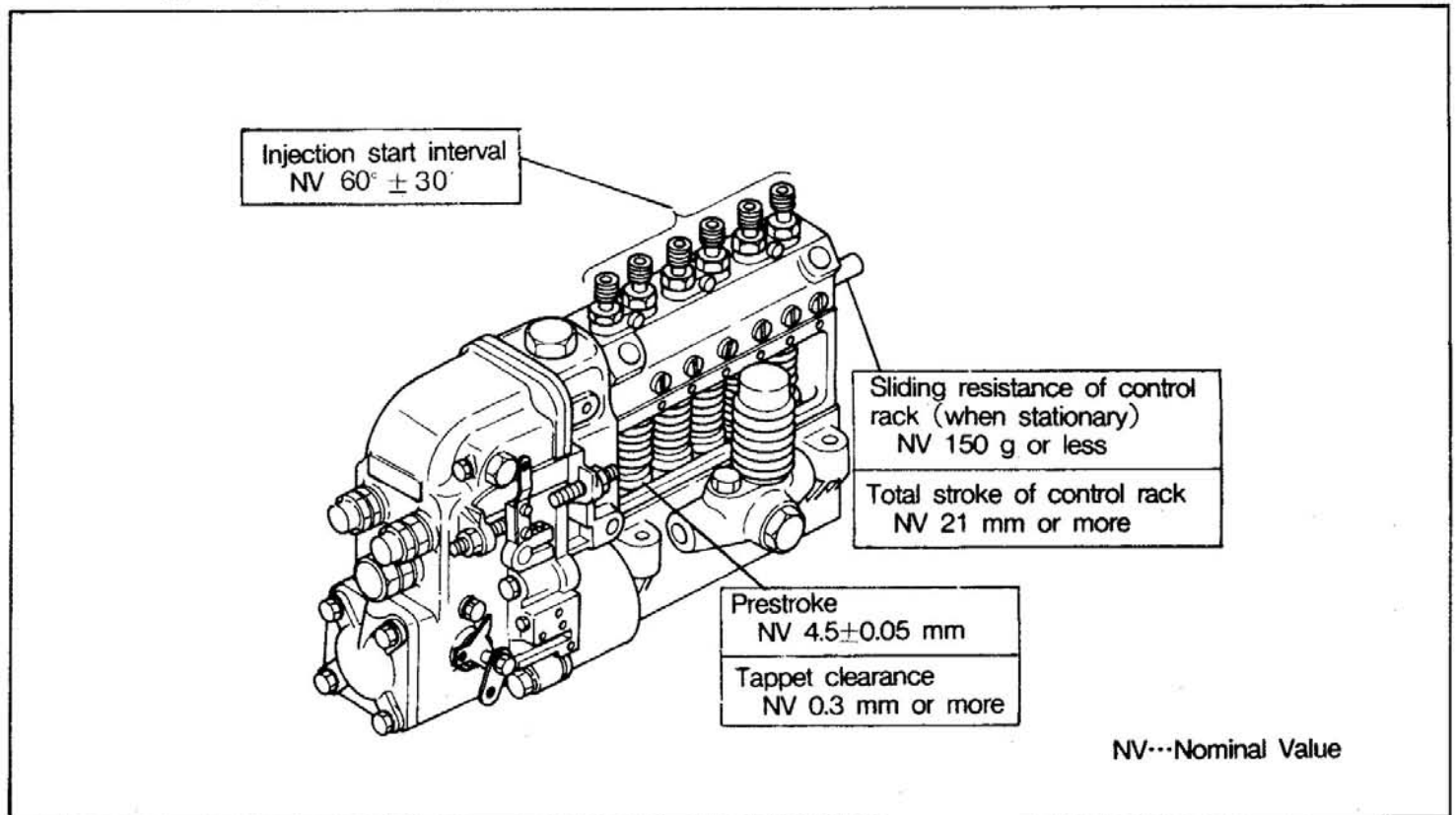

NOTE : Supply oil to the injection pump cam chamber.

(a) Setting position O of control rack

Mount special tool(Measuring Device) to the injection pump.

Temporarily set the speed control lever so that with the injection pump at 500 to 600 rpm, the governor will provide high speed control.

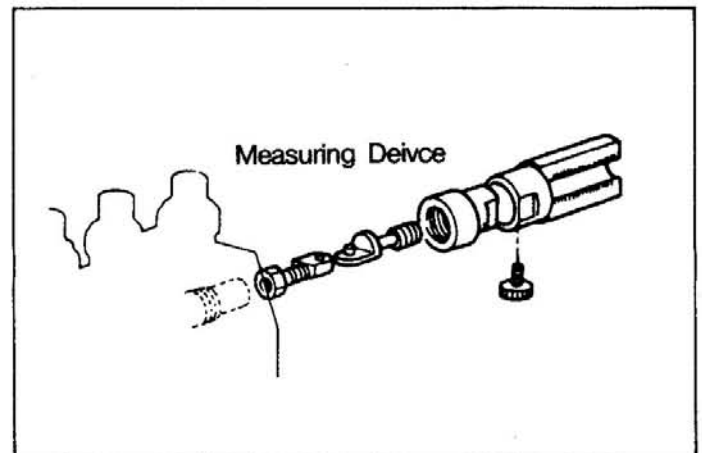

Increase the speed further to have the control rack pulled, and simultaneously push the control rack all the way in.

Regard this position of the control rack as "O" and set the scale "O" of the measuring device to this position.

NOTE : If the position O is set by operating the load control lever without rotating the injection pump, there is the possibility that the link mechanism and other parts of the governor will be damaged. Do not set the position O by operating the load control lever.

(b) Checking stroke of control rack

Move the control rack to confirm that the total stroke is over the specified value.

In addition, check to see that the start spring and idling spring smoothly move the control rack in the maximum injection direction.

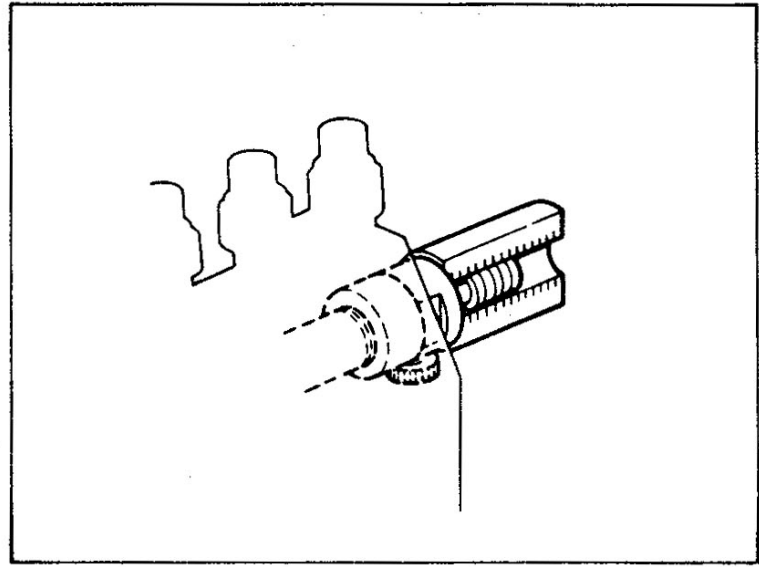

(c) Adjusting prestroke

1) Pull the control rack out to the total injection position and secure it there.

2) Place the plunger of the No. 1 cylinder in the bottom dead center position and mount special tool (Measuring Device). Set the contactor on the tappet.

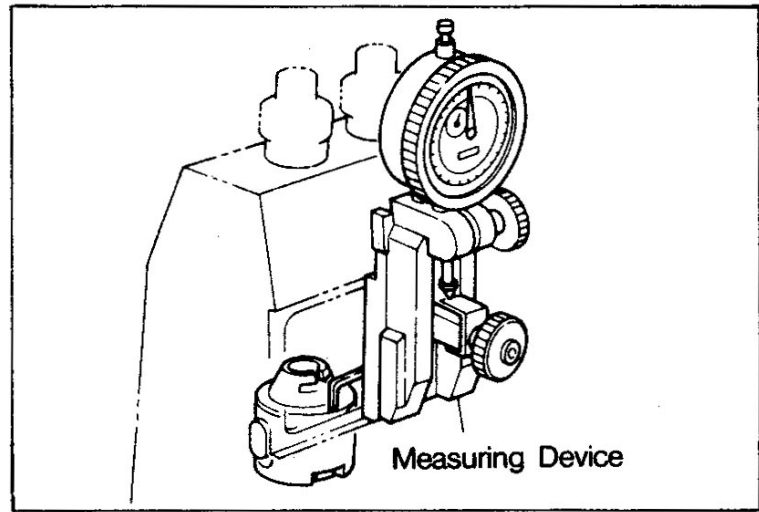

3) Couple the injection pump and tester nozzle.

4) Send a high pressure fuel into the injection pump to let the fuel flow out from the overflow pipe of the nozzle holder.

NOTE : The pressure of the fuel forced into the injection pump must be higher than the delivery valve opening pressure.

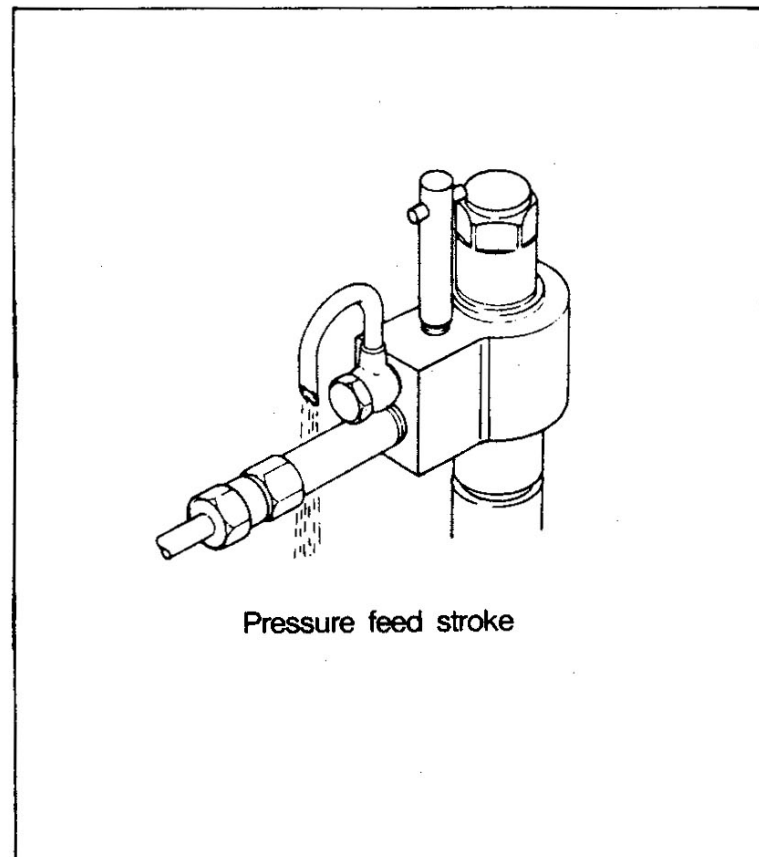

- 5) Slowly turn the camshaft until the fuel ceases to flow from the overflow pipe of the nozzle holder (until static injection begins).

NOTE : Make measurement by turning the camshaft clockwise.

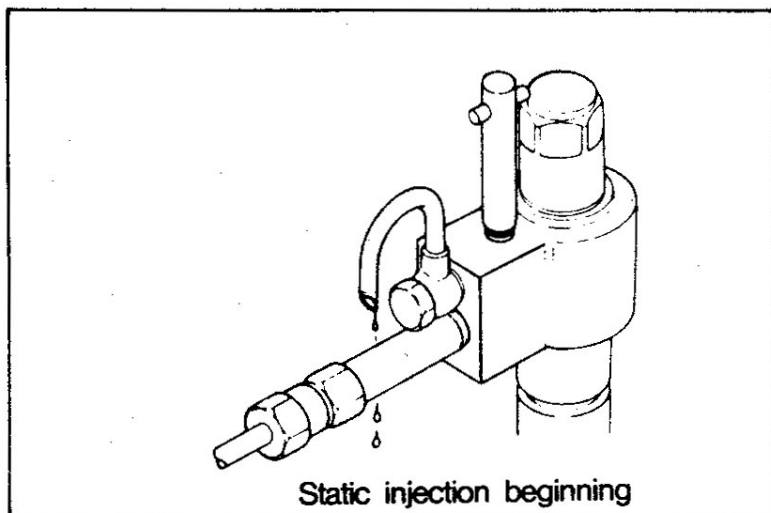

- 6) Read the prestroke from the bottom dead center to the point where the fuel ceases to flow (static injection begins), using a dial gauge.

If the prestroke is out of specification, adjust by shims. [Refer to (d).]

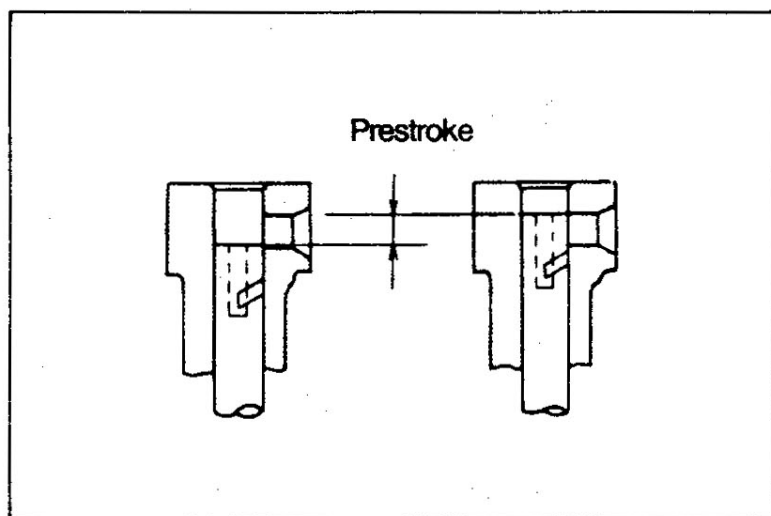

- 7) After adjustment of the prestroke, check to see that, at the static injection beginning, the inscribed lines of the pointer and timer are in alignment.

If they are out of alignment, res-tamp a line on the automatic timer.

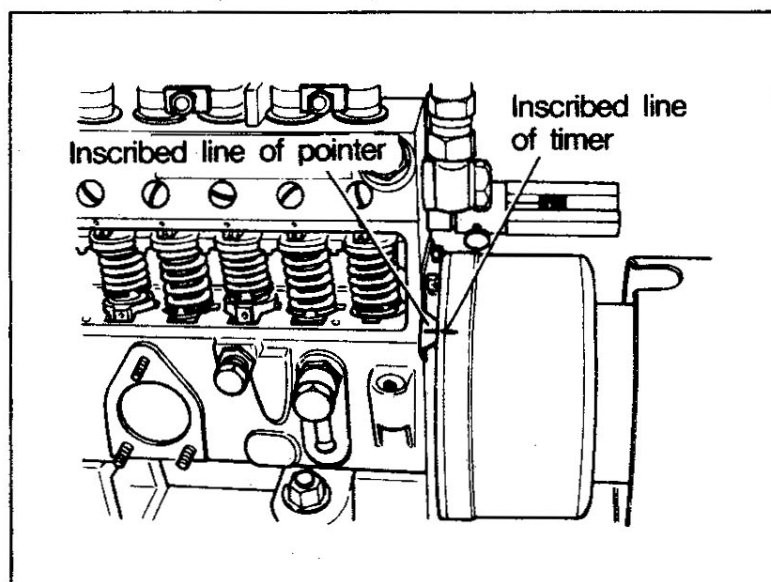

(d) Adjustment of injection start interval

- 1) Couple tester nozzles to all the cylinders of the injection pump as in the case of adjustment of the prestroke.
- 2) Force fuel into the injection pump to let the fuel flow out from the tester nozzle.
- 3) On the basis of the static injection beginning of the No. 1 cylinder, measure the interval when the fuel ceases to flow out according to the injection sequence, using an angle scale.

NOTE : Injection sequence

1-5-3-6-2-4

- 4) If the prestroke and injection start interval are out of specification, insert a special tool (Holder) between the tappet and lower seat and then adjust by changing the shim thickness.

Shim thickness

29 Kinds from 0.20 to 1.60mm,
0.05mm apart

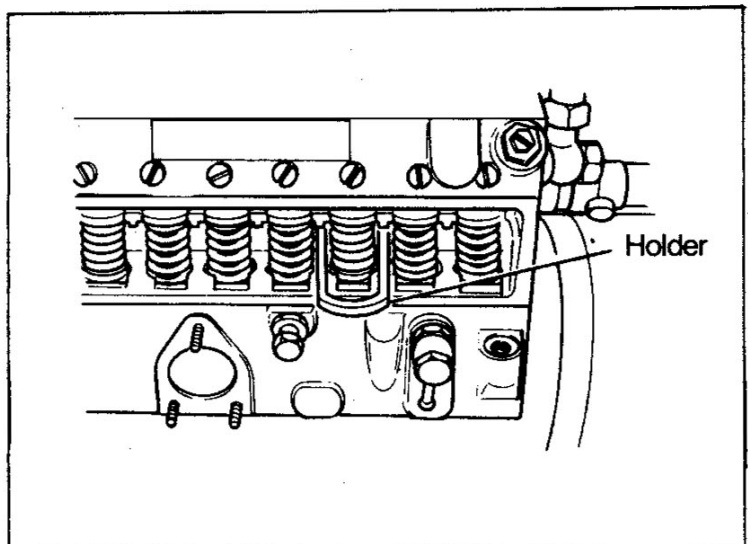
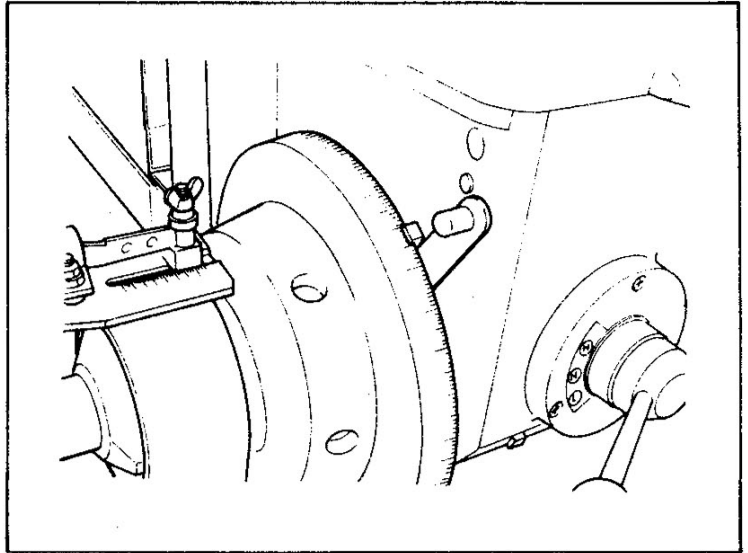

(e) Adjustment of tappet clearance

- 1) Place the tappet in the top dead center position.
- 2) Raise the tappet with a screwdriver, etc. until the driving face of the plunger touches the bottom end of the plunger barrel.
- 3) Measure the stroke of the tappet from the top dead center to the point where the plunger barrel is touched.
- 4) If the tappet clearance is less than the nominal value, adjust within the extent permitted by the injection start interval.

If correction within the permitted extent is impossible, set the prestroke of the No. 1 cylinder to the maximum of the set value and readjust.

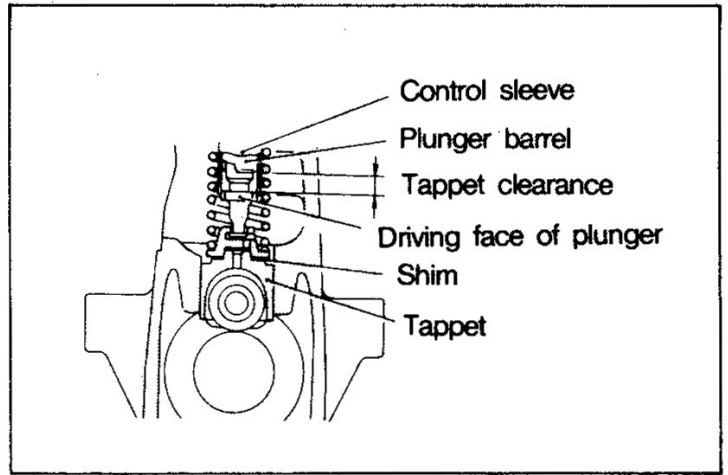

(f) Adjustment of fuel injection amount

To check whether the injection amount is up to specification at the specified rack position and speed, measure with a measuring cylinder.

If the injection amount is out of specification, adjust by the following procedures.

- 1) Loosen the screw of the pinion.
- 2) While blocking movement of the control rack, turn the control sleeve with an adjusting rod.
- 3) Tighten the screw of the pinion.

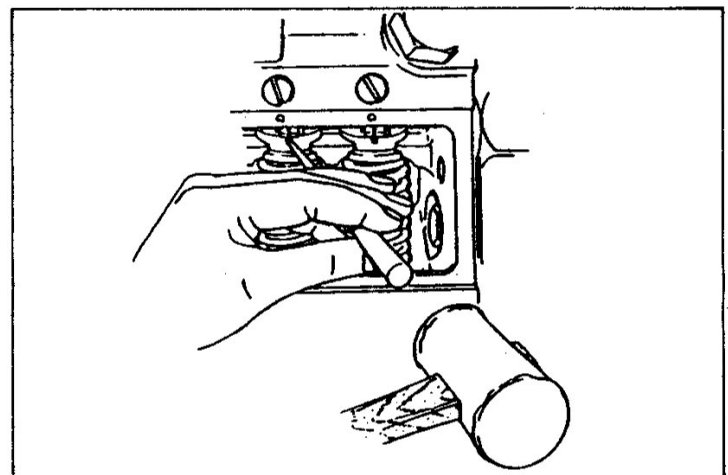

NOTE : 1. A maladjusted injection amount will produce marked effects on engine performance. Make sure the injection amount is carefully adjusted.

2. The injection amount varies on different nozzles and pipes. Make sure that the measuring conditions are observed.

3. Injection amount uneven ratio

$$\text{Uneven ratio}(+) = \frac{\text{Maximum injection amount in each cylinder} - \text{Average injection amount of each cylinder}}{\text{Average injection amount of each cylinder}} \times 100(\%)$$

$$\text{Uneven ratio}(-) = \frac{\text{Maximum injection amount in each cylinder} - \text{Average injection amount of each cylinder}}{\text{Average injection amount of each cylinder}} \times 100(\%)$$

(g) Final adjustment of injection amount

Adjustment of load control lever

With the load control lever fixed at the full load position, operate the injection pump at the specified speed.

Finely adjust the stopper bolt of the load control lever so that the injection amount at the time will be up to specification.

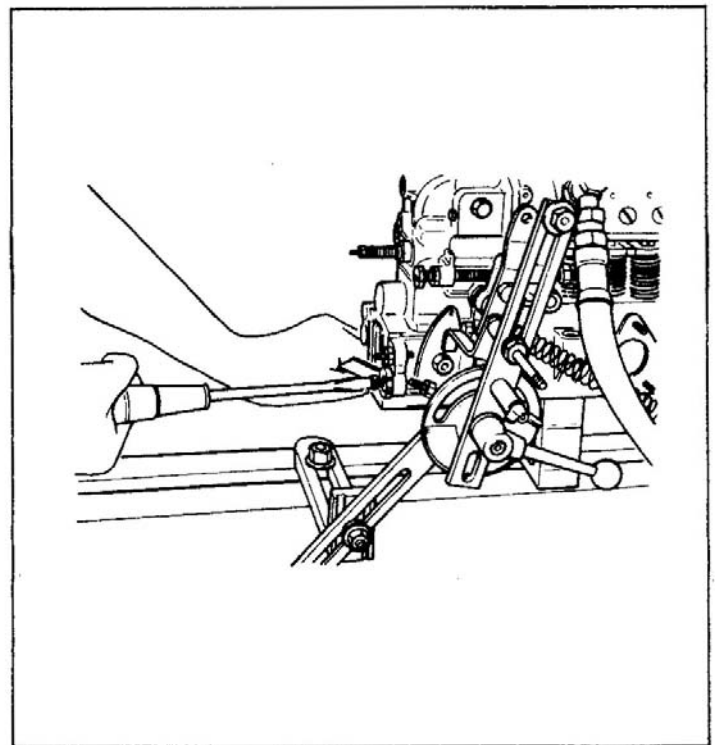

(2) P Type Injection Pump

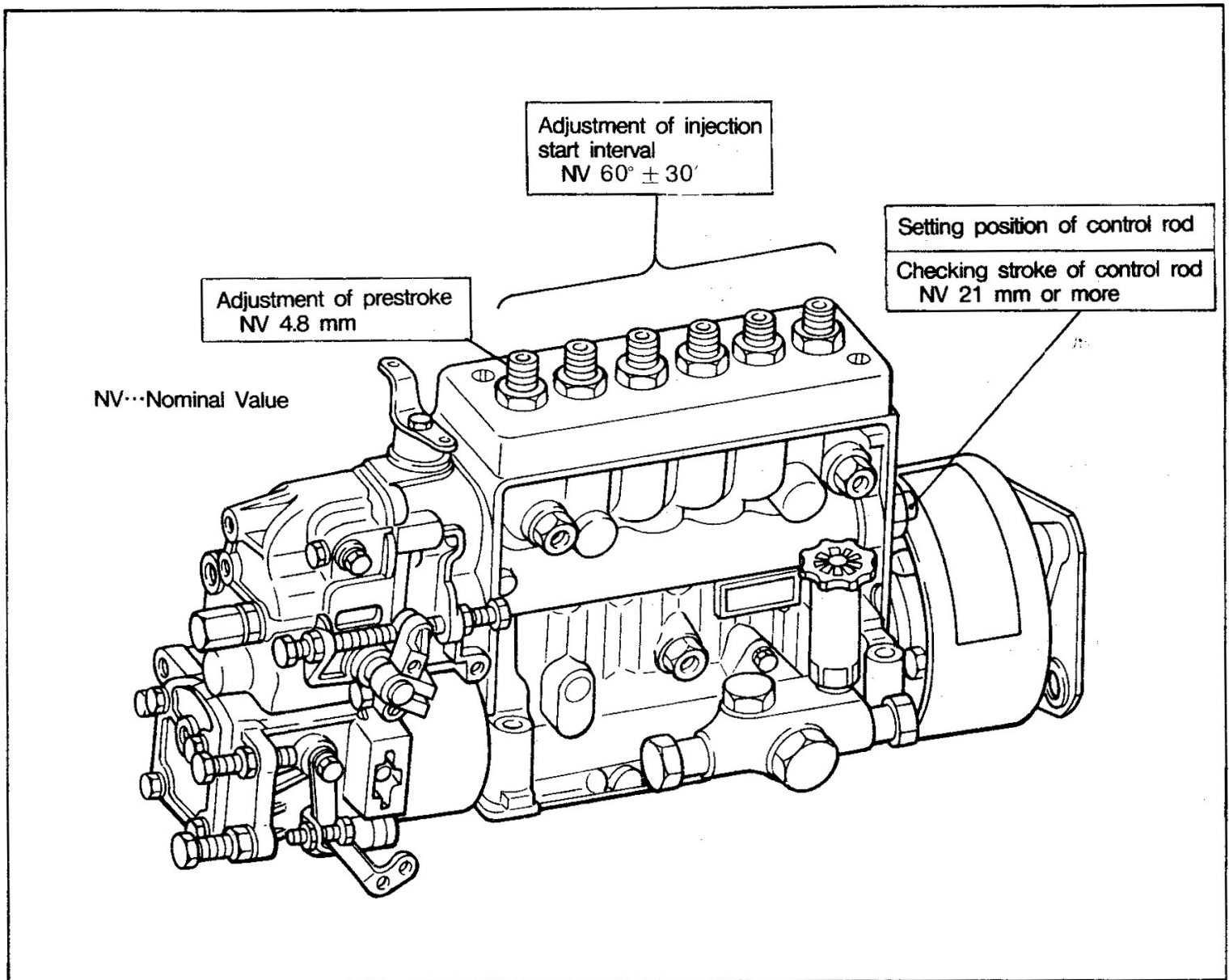

NOTE : 1. Supply oil to the injection pump cam chamber.

2. Adjust the injection amount after adjustment of the governor.

(a) Mount two special tools(Fixing Stands) to an injection pump tester.

Secure the injection pump firmly to the special tools.

NOTE : To make sure that the coupling and injection pump rotate smoothly, align the centers of the coupling and injection pump accurately.

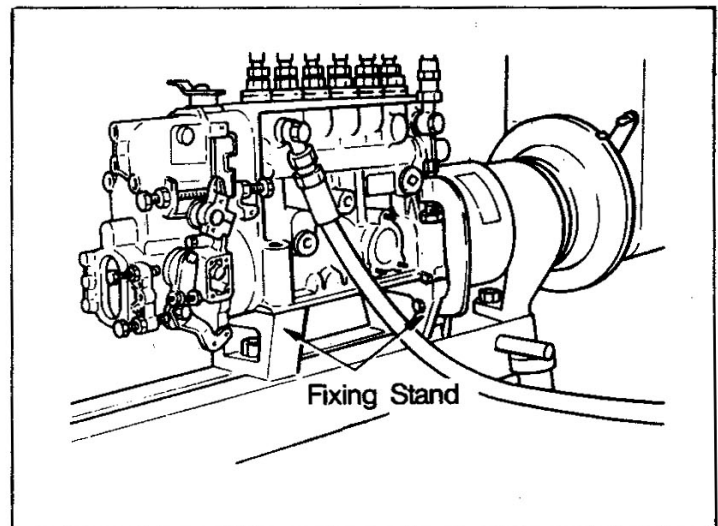

(b) Setting position "O" of control rod

Remove the smoke set assembly, mount special tool (Measuring Device) there instead, and couple it with the control rod. Set the speed control lever so that the control will begin when the injection pump reaches a speed of 500 to 600 rpm. In this condition, increase the pump speed to have the control rod pulled back. At the same time, push the control rod all the way in until it becomes stationary. This position is the position "O" of the control rod. Adjust the point "O" of the scale.

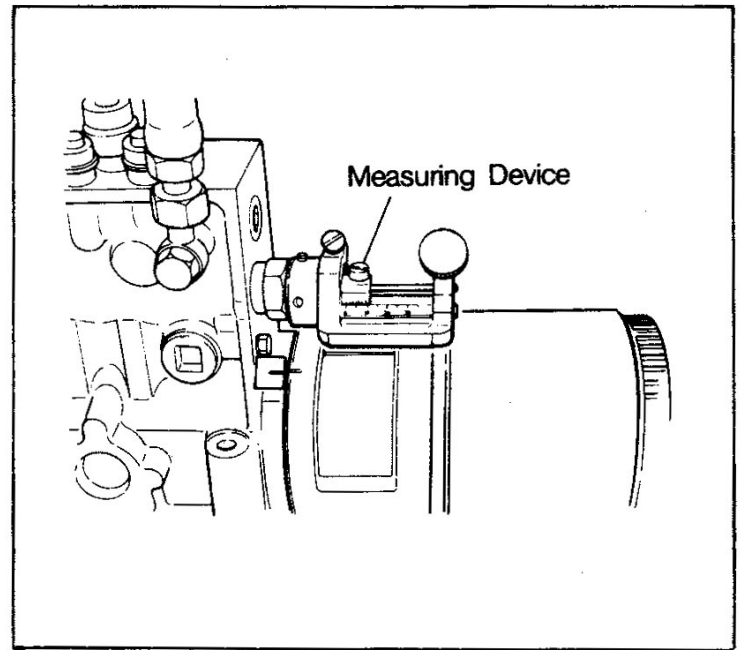

NOTE : 1. If the position "O" of the control rod is set by operating the load control lever, there is danger of damage to the link mechanism and other parts of the governor.

Do not set the position "O" by operating the load control lever.

2. When the position "O" is set, remove the damper spring beforehand.

(c) Checking stroke of control rod

Move the control rod to confirm that the total stroke is more than the specified value.

Check to see that the control rod is moved smoothly in the maximum injection amount direction by the start spring and idling spring.

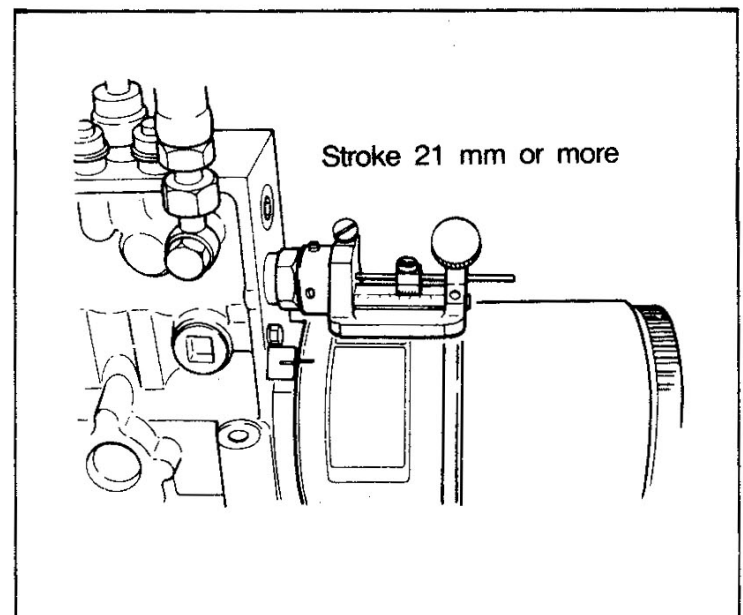

(d) Adjustment of prestroke

- 1) Remove the governor side No. 1 cylinder delivery valve holder, spring, delivery valve and gasket.
- 2) Mount special tool (Measuring Device) to the flange sleeve.
- 3) Turn the flywheel of the pump tester to detect the bottom dead center of the plunger with a dial gauge.
- 4) With the control rod set in the full position, force a high pressure fuel into the injection pump to let the fuel flow out from the overflow pipe.
- 5) Slowly turn the flywheel of the pump tester clockwise until the fuel ceases to flow out from the overflow pipe (until static injection begins).
- 6) Measure the prestroke of the plunger from the bottom dead center to the point where the fuel ceases to flow out (static injection beginning).

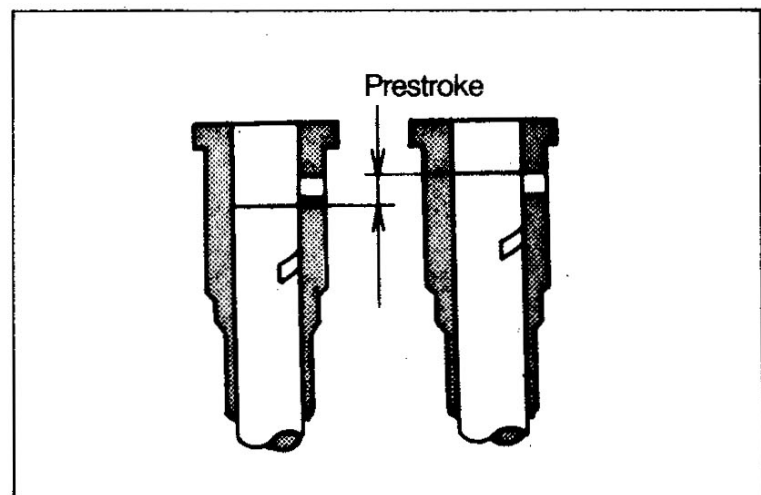
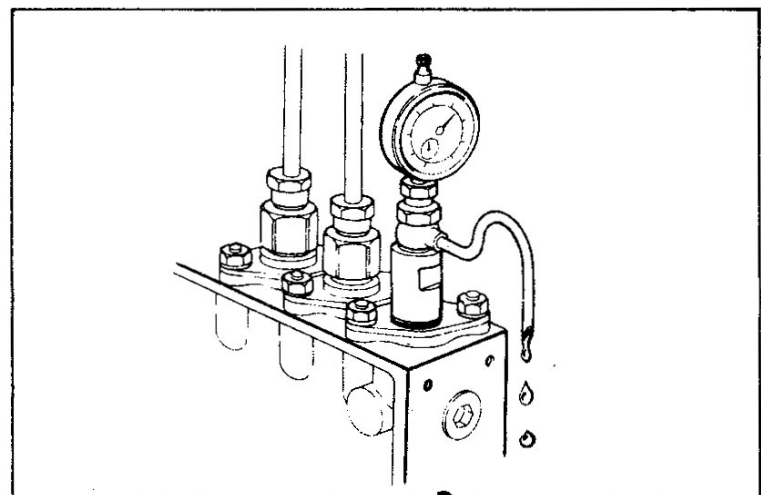
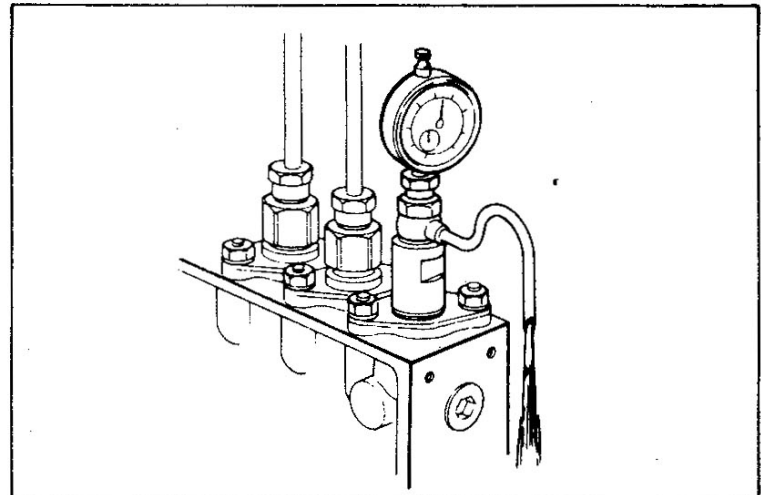
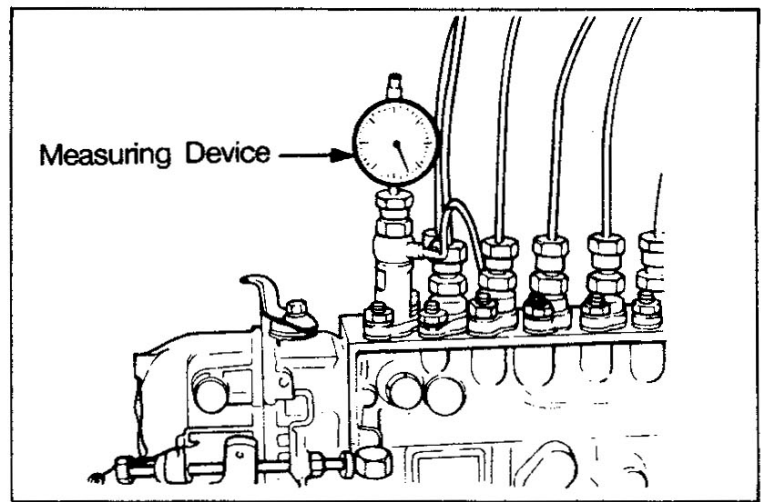

7) If the prestroke is out of specification, adjust by changing the shim thickness between the flange sleeve and pump housing.

Shims(8 types) $t=0.15, 0.4, 0.5, 0.6, 0.7, 0.8, 0.9, 1.5\text{mm}$

If the prestroke is smaller, increase the thickness. If the prestroke is larger, reduce the thickness.

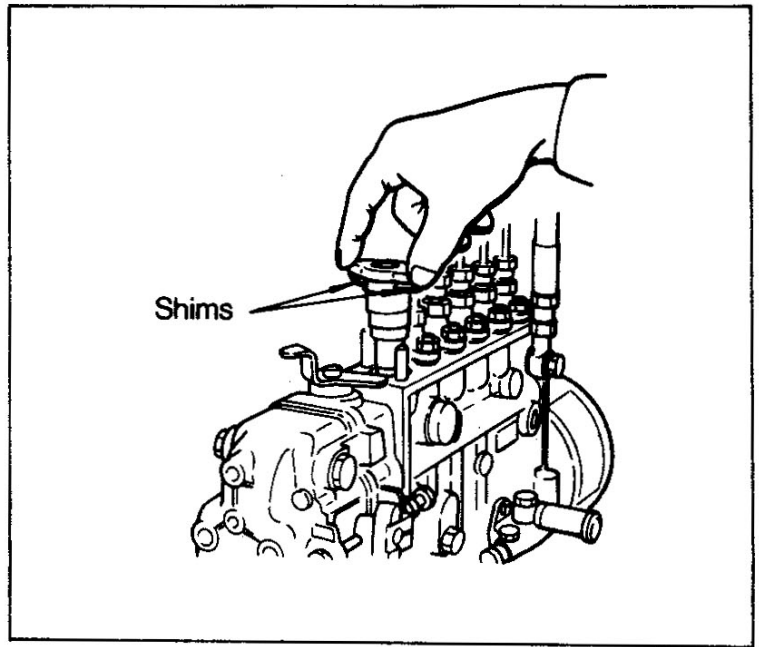

NOTE : To install the plunger block, apply grease to each O-ring. After inserting the O-ring in the lower part of the plunger barrel into the pump housing in advance, apply grease to the skirt portion of the plunger barrel and then install the plunger barrel.

8) After adjustment of the prestroke, check to see that the inscribed line of the timer and that of the pointer are in alignment.

If they are out of alignment, inscribe another line on the timer. When the automatic timer was replaced with a new one, proceed in the same way.

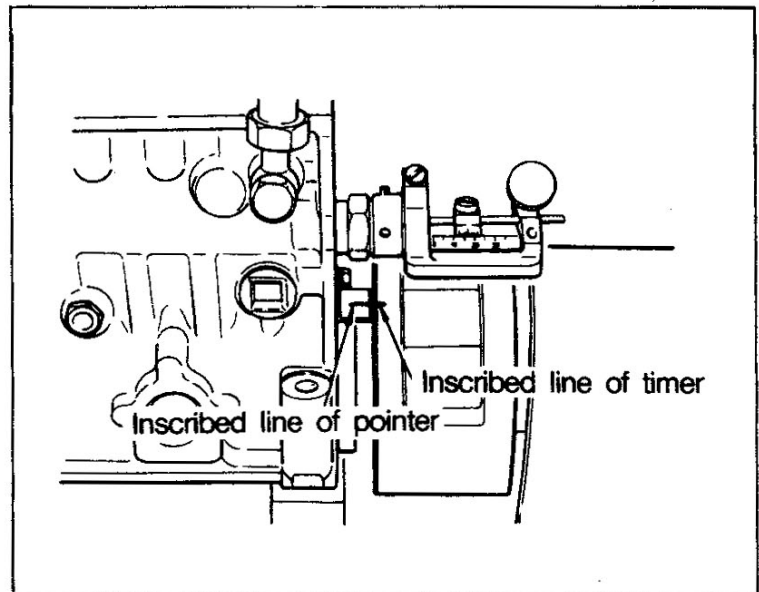

(e) Adjustment of injection start interval

1) Set the static injection beginning position of the No. 1 cylinder on the pump tester scale plate.

2) Force a high pressure fuel into the injection pump to let the fuel

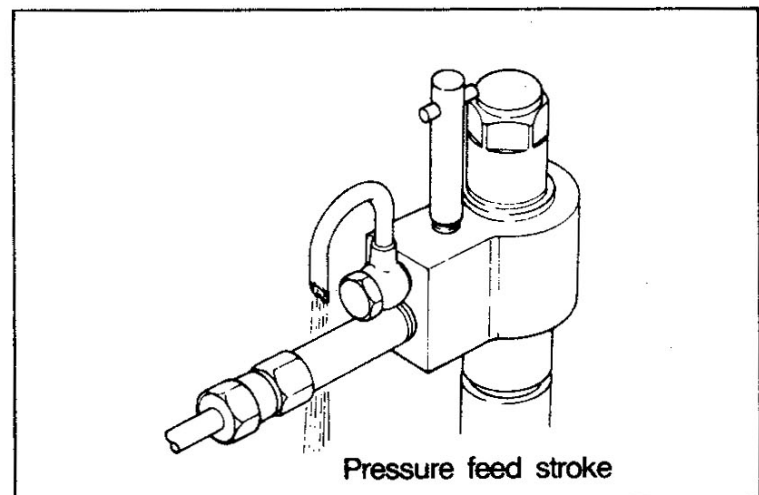

flow out from the overflow pipe of the tester nozzle.

NOTE : The pressure of the fuel forced into the injection pump must be higher than the delivery valve opening pressure.

- 3) Slowly turn the flywheel of the pump tester clockwise until the fuel ceases to flow out from the tester nozzle.

Read the rotation angles (injection start intervals) where the fuel ceases to flow, according to the injection sequence.

- 4) If the injection start interval is out of the standard angle, adjust by the same procedures as for prestroke adjustment.

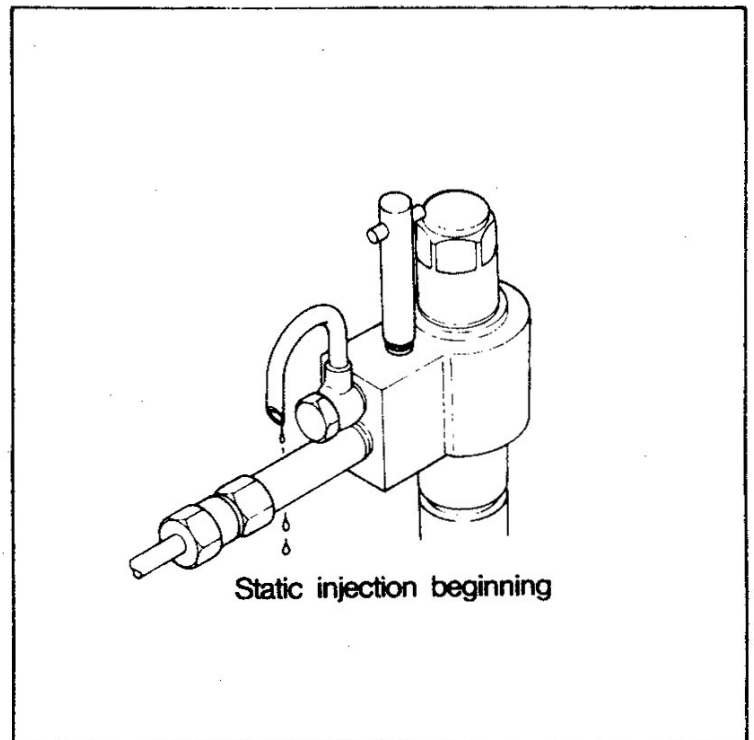

NOTE : Injection sequence

1-5-3-6-2-4

- (f) Adjustment of fuel injection amount

At the specified rack position and speed, measure the injection amount and uneven ratio with a measuring cylinder to check whether they are up to specification.

If the injection amount is out of specification, adjust by the following procedures.

- 1) Loosen the two nuts tightening the flange sleeve.
- 2) Turn the flange sleeve by lightly striking.
- 3) Tighten the nuts to the specified torque to secure the flange sleeve. [39 to 44 N m (4 to 4.5kgf m)]

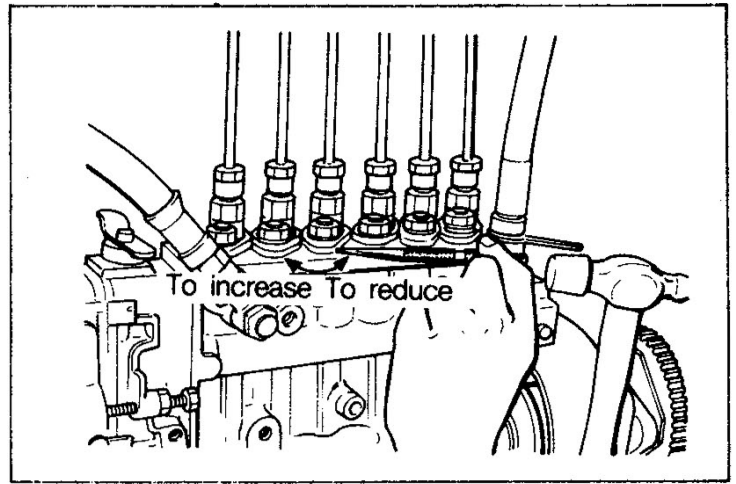

Perform the operations repeatedly.

NOTE : 1. A maladjusted injection amount will produce considerable effects on engine performance. Make sure that the injection amount is carefully adjusted.

2. Since the injection amount varies on different nozzles and pipes, make sure that the measuring conditions are observed.
3. Injection amount uneven ratio

$$\text{Uneven ratio(+)} = \frac{\text{Maximum injection amount in each cylinder} - \text{Average injection amount of each cylinder}}{\text{Average injection amount of each cylinder}} \times 100(\%)$$

$$\text{Uneven ratio(-)} = \frac{\text{Maximum injection amount in each cylinder} - \text{Average injection amount of each cylinder}}{\text{Average injection amount of each cylinder}} \times 100(\%)$$

(g) Final adjustment of injection amount

Adjustment of load control lever

Place the load control lever in the full load position and operate the pump at the specified speed.

Finely adjust the stopper bolt of the load control lever so that the injection amount will be up to specification.

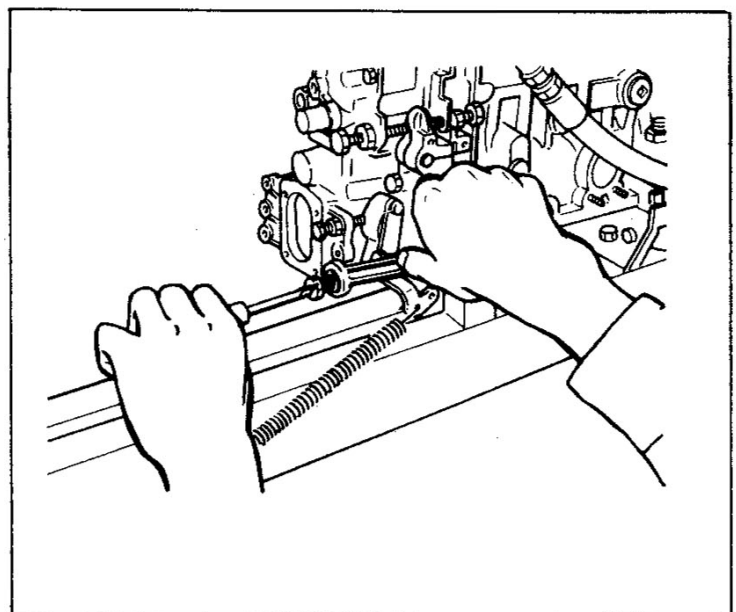

(a) Setting position "O" of control rack
[Refer to 11-1-8(1) (a).]

(b) Adjustment of intermediate speed control

This adjustment is aimed at determining the control rack position, point C (maximum injection amount) when the injection pump is at full load.

Operate the injection pump at N_c speed, press down the adjusting lever so that the governor spring in the governor will be given considerable tension, and temporarily secure the lever in the position.

Then adjust the full load stopper so that the control rack will be positioned at R_c .

Clockwise rotation of the full load stopper, as viewed from the rear of the governor, will move the rack in the direction fuel is increased.

Counter-clockwise rotation will move the rack in the direction fuel is decreased.

(c) Adjustment of ungleich device

Fix the adjusting lever at the maximum speed stopper position. Adjust the adapter screw so that when the speed is changed from N_a to N_b , the rack position will move from R_a to R_c .

The stroke of the rack position from R_a to R_c is called the ungleich stroke.

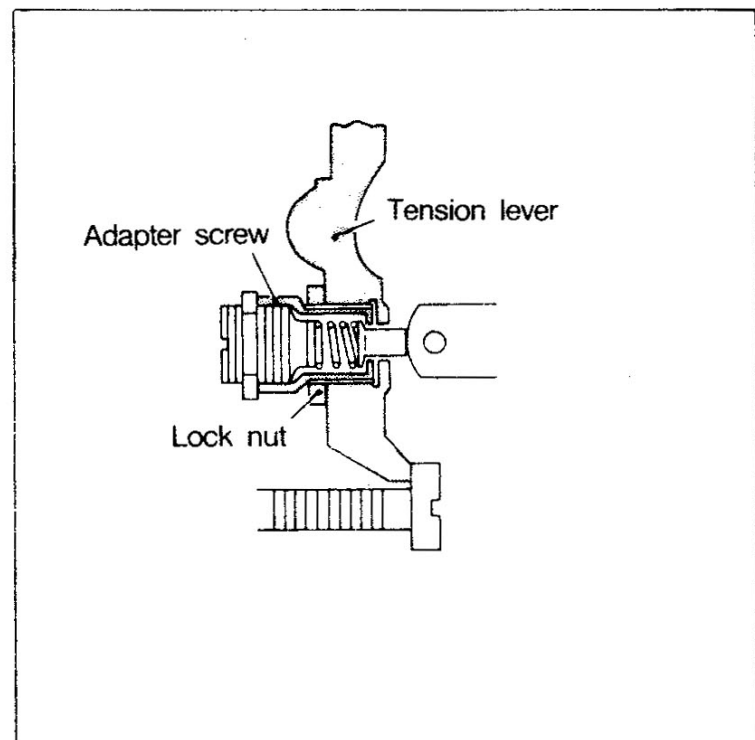
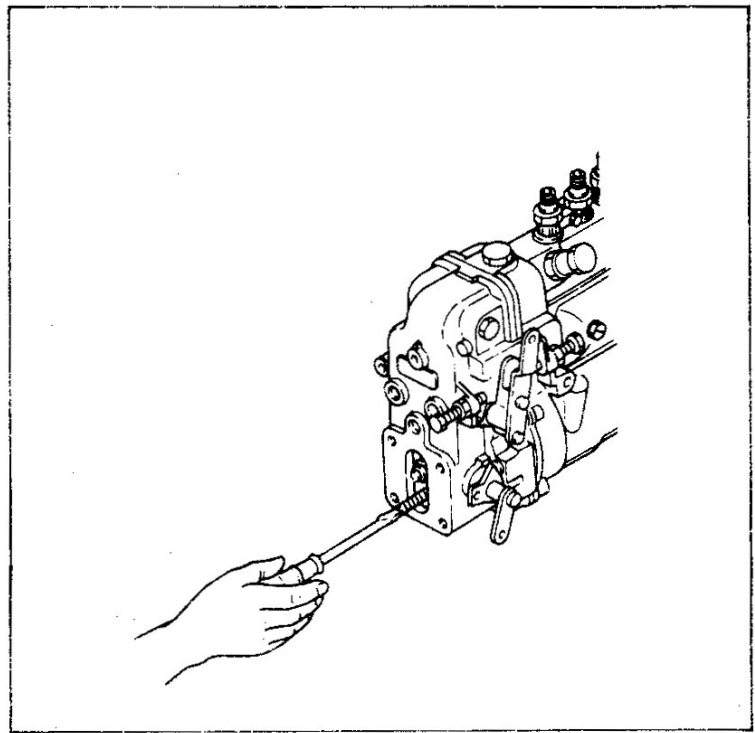

Tightening the adapter screw will increase the ungleich stroke.

Loosening it will reduce the ungleich stroke.

Adjust with special tool (Special Wrench) so that the rack will be positioned at R_a when the speed is N_a .

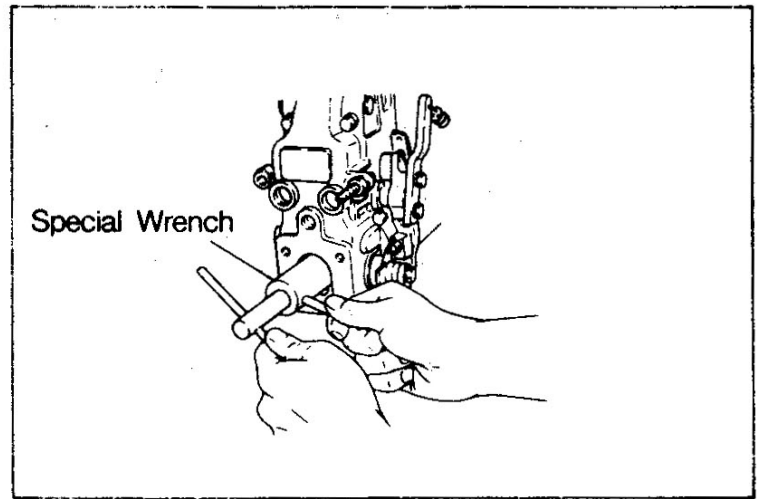

(d) Adjustment of low speed control

1) Adjustment of stopper bolt

Operate the pump at N_i speed, press down the adjusting lever and adjust with the stopper bolt so that the control rack will be positioned at R_i .

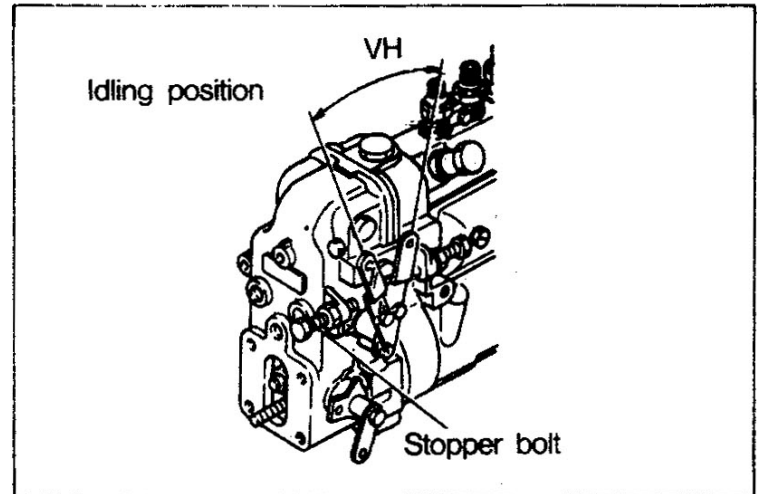

2) Adjustment of idling sub spring

Adjust the idling sub spring so that the rack will be positioned at R_h with the pump at N_h speed.

Reduce the speed and check to see that the rack is positioned at R_g when the speed is N_g .

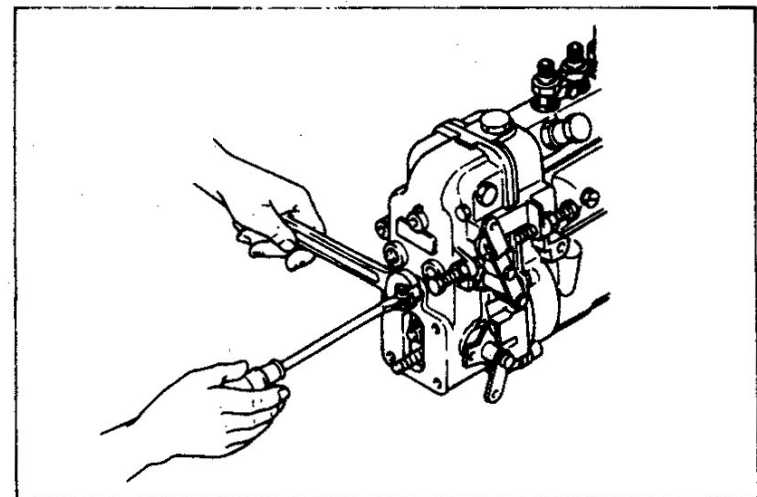

(e) Adjustment of high speed control

1) Adjustment of high speed control start point

Press down the adjusting lever and determine the maximum control speed of the governor.

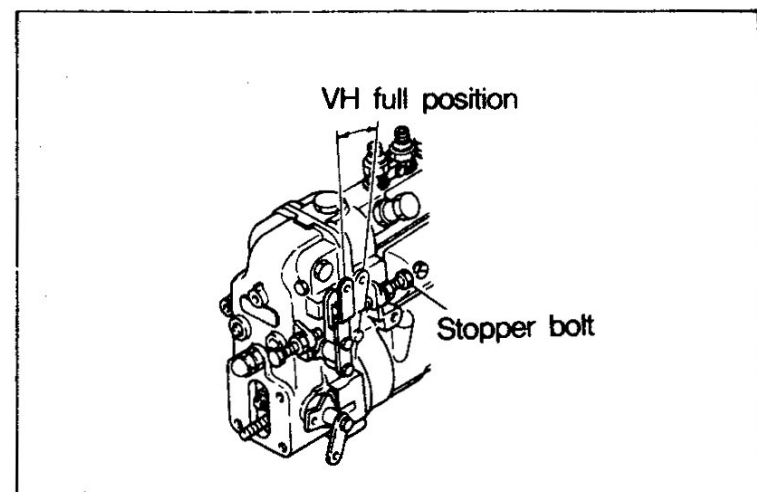

Slowly increase the pump speed from N_c and press down the adjusting lever and adjust the maximum speed stopper so that when the speed reaches N_d , the control rack will begin to retreat from the position R_c .

2) Adjustment of speed variation rate

Increase the pump speed from N_d and check to see that when the speed reaches N_e , the rack position is pulled back to R_e .

If it is out of specification, adjust the amount the adjusting screw of the swivel lever is turned down.

Tightening the screw will improve the speed variation rate.

Loosening it will worsen the speed variation rate.

$$\text{Speed variation rate} = \frac{N_e - N_d}{N_d} \times 100(\%)$$

NOTE : 1. If the variation rate is poor, the engine will exceed the specified maximum speed at no load and will enter a hazardous condition.

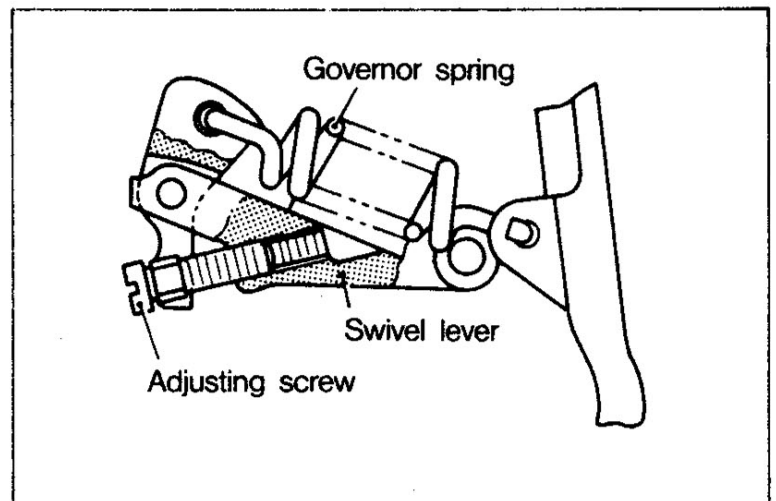
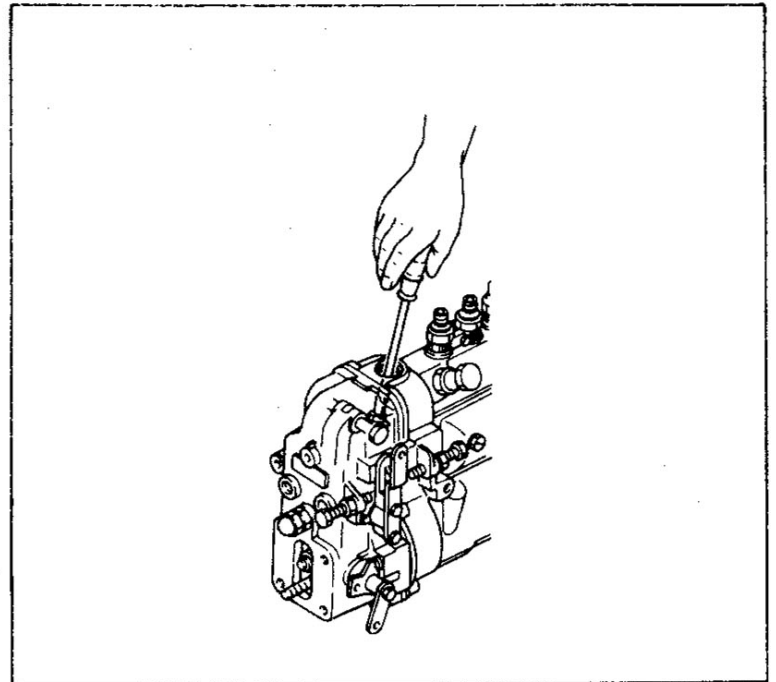

2. The maximum extent to which the adjusting screw can be loosened is 20 notches (5 rotations) from the fully tightened position. Loosening it any further can be dangerous.
3. If the adjusting screw is adjusted, the tension of the governor spring will change and the high speed control start point will change. Make sure that the high speed control start point of Item 1) is readjusted.

(f) Checking operation of stop lever

Check to see that when the stop lever is pulled all the way toward the stop side with the injection pump at full load, the rack is positioned at 0 mm.

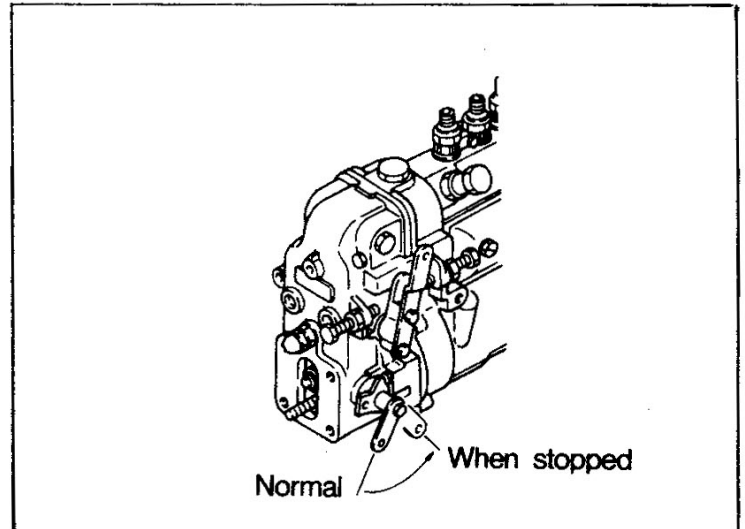

(g) Adjustment of torque spring

Press down and fix the control lever at the maximum stopper bolt position, slowly increase the pump speed from N_a , and set the torque spring so that the rack position will pass through the points B and C.

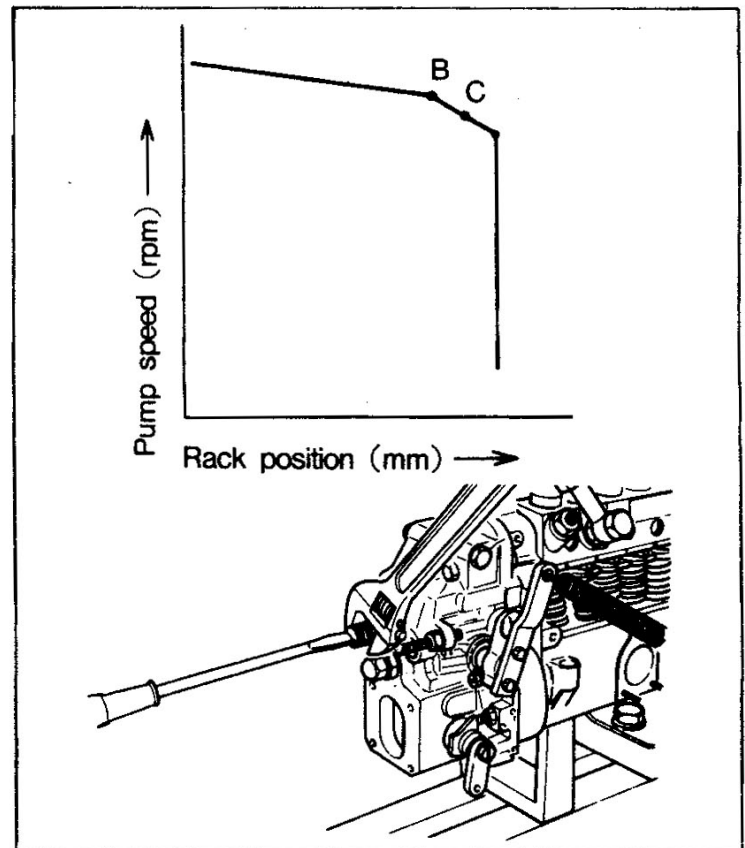

(h) Adjustment for adaptation to engine

After the governor adjustment has been completed, measure and adjust the total injection amount at the same lever angle as at the time of high speed control according to the adjustment standards.

(4) RFD Type Governor

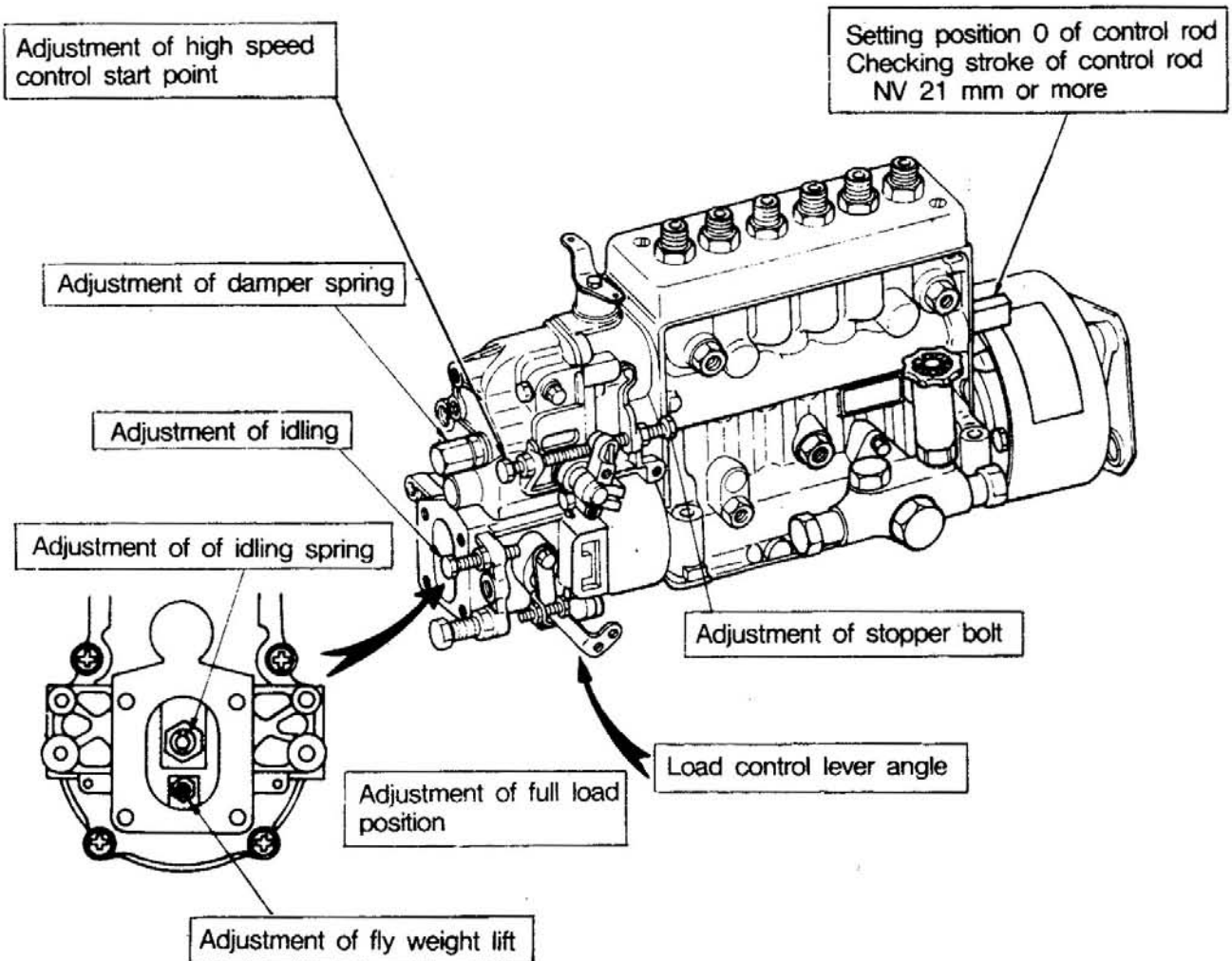

NV...Nominal Value

NOTE : 1. Remove the damper spring.

2. Remove the idling spring.

3. Keep the stopper bolt of the speed control lever loosened.

4. Keep the stopper bolt of the load control lever loosened.

5. Supply engine oil to the injection pump cam chamber.

Adjust the relation between pump speed and rod position to the specified governor performance diagram and perform adjustments in the following sequence.

The governor performance diagram varies on different specifications.

- (a) Setting position "O" of control rod
[Refer to 11-1-8 (2) (b).]
- (b) Checking stroke of control rod
[Refer to 11-1-8 (2) (c).]

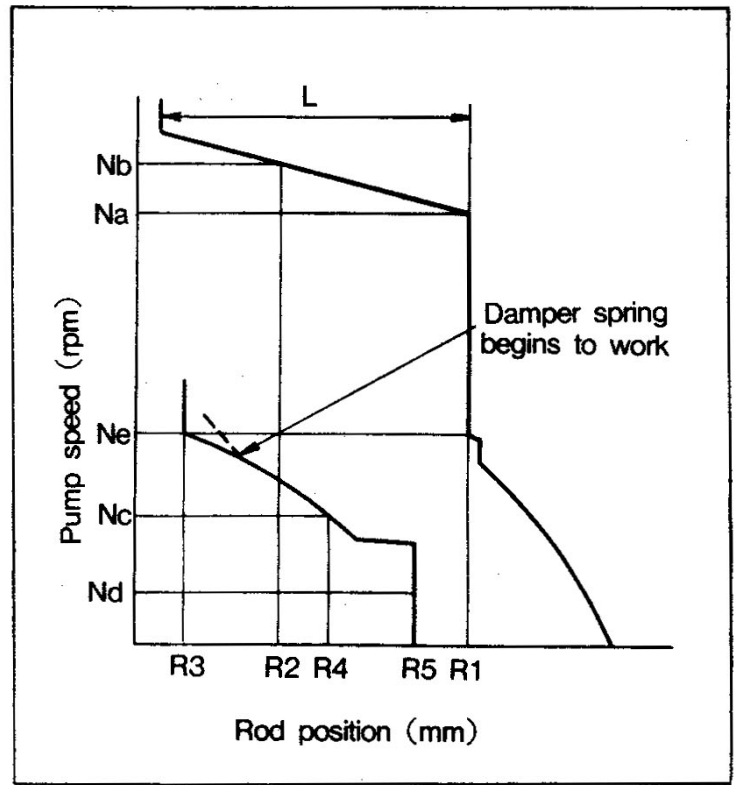

(c) Adjustment of flyweight lift

Divide the total lift of flyweight between a lift necessary for high speed control and that necessary for idling control.

- 1) Temporarily set the speed control lever so that high speed control will be performed with the pump at 500 to 600 rpm.
- 2) Keep the load control lever in the full load direction.
- 3) Slowly increase the pump speed and adjust the stroke adjusting bolt so that the pull-back stroke (L) from the control start point C to the end point A will be up to specification.

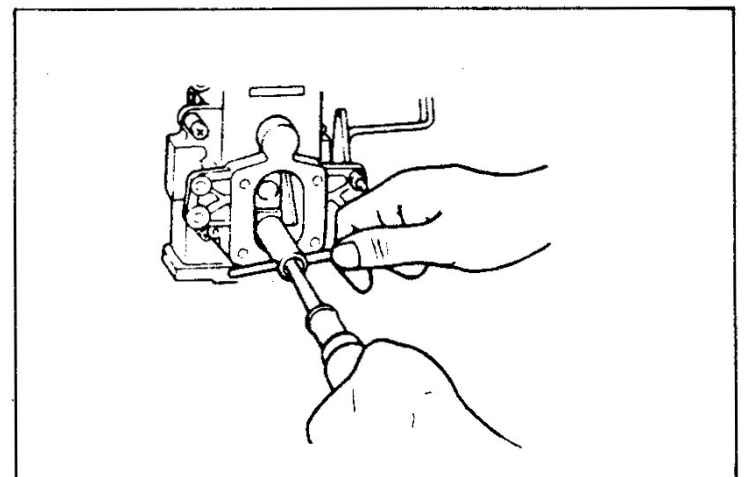
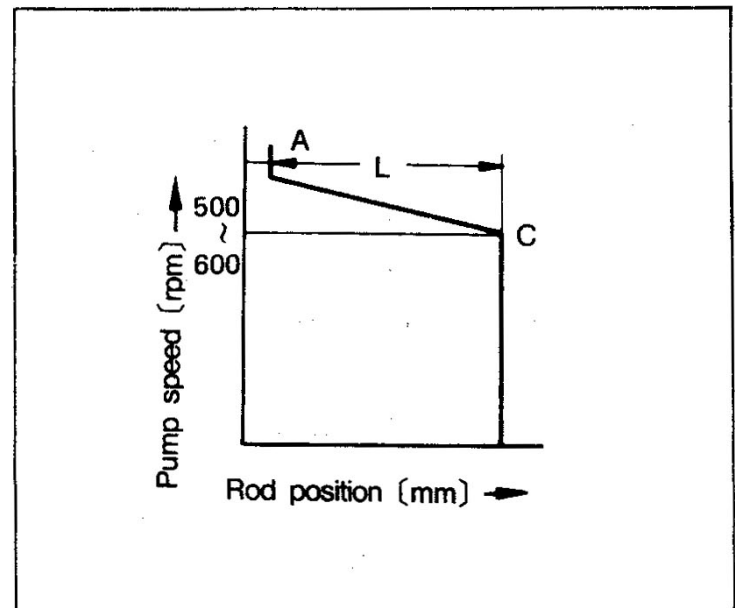

(d) Adjustment of high speed control

1) Adjustment of full load position

Adjust the pump speed to 500 to 600 rpm.

Temporarily adjust the load control lever with the full load stopper bolt so that the control rod will be positioned at R_1 .

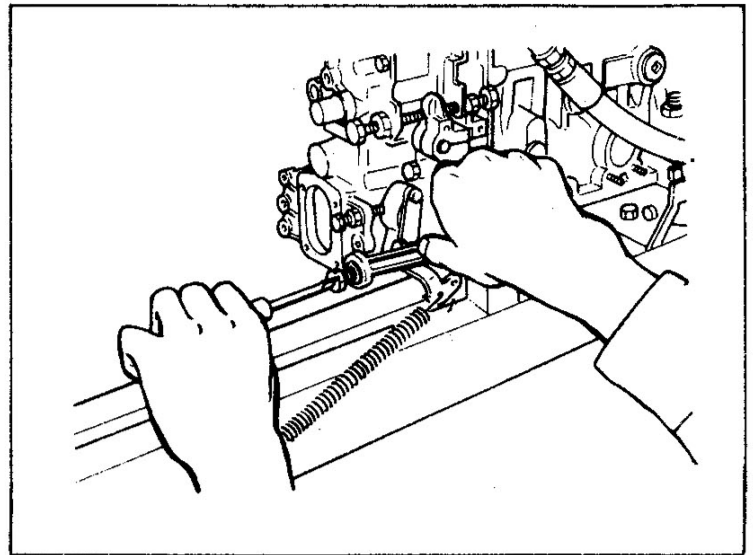

NOTE : The correct position R_1 is determined on the basis of the injection amount.

2) Adjustment of high speed control start point

Fix the load control lever at the full load position.

Slowly increase the pump speed and adjust the stopper bolt of the speed control lever so that when the pump speed reaches N_a , the control rod will retreat from the position R_1 .

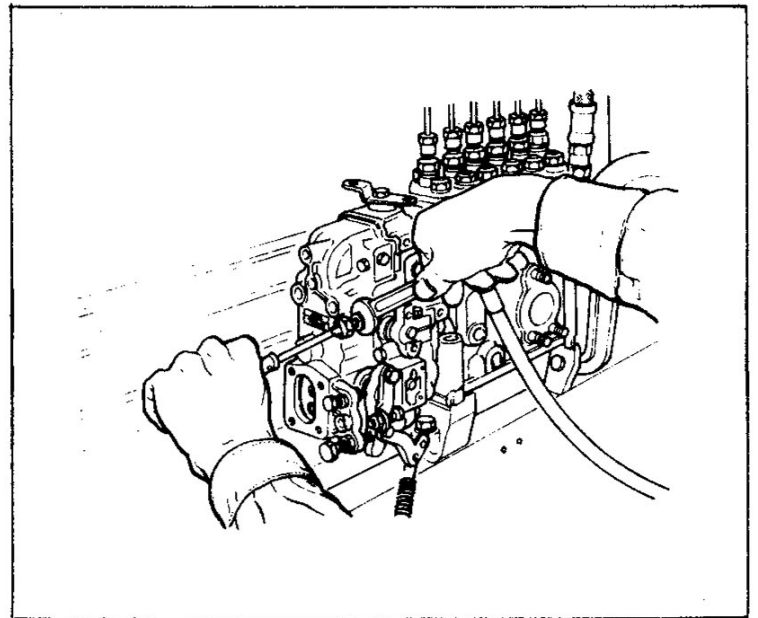

3) Checking speed variation rate

Slowly increase the pump speed until the control rod is pulled back to the position R_2 .

Check to ensure that when the rod reaches the position R_2 , the pump speed is N_b .

Increase the pump speed further and check to ensure that the control rod pull-back stroke L is up to specification.

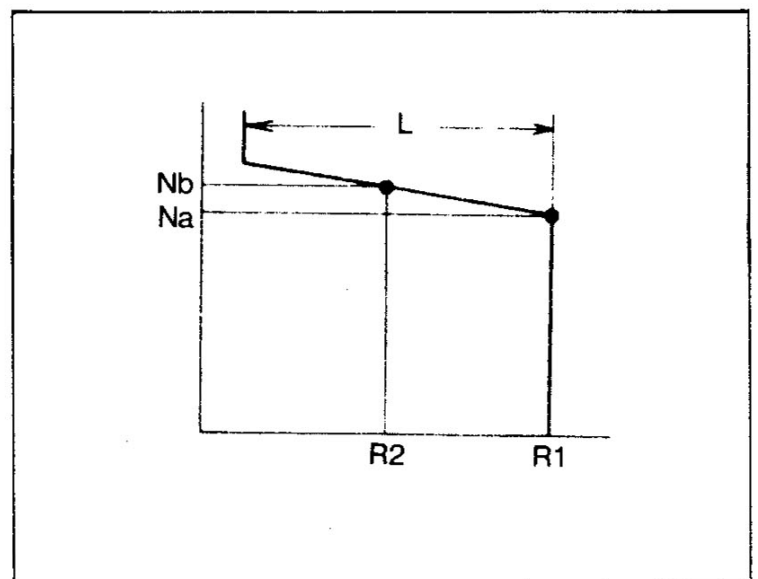

NOTE : If the speed variation rate is poor, the engine will exceed the specified maximum speed at no load and will enter a hazardous condition.

4) Adjustment of stopper bolt

With the load control lever fixed at the full load position, turn down the stopper bolt of the speed control lever.

NOTE : Adjustment of the stopper bolt should be performed after adjustment of the high speed control start point and checking the speed variation rate.

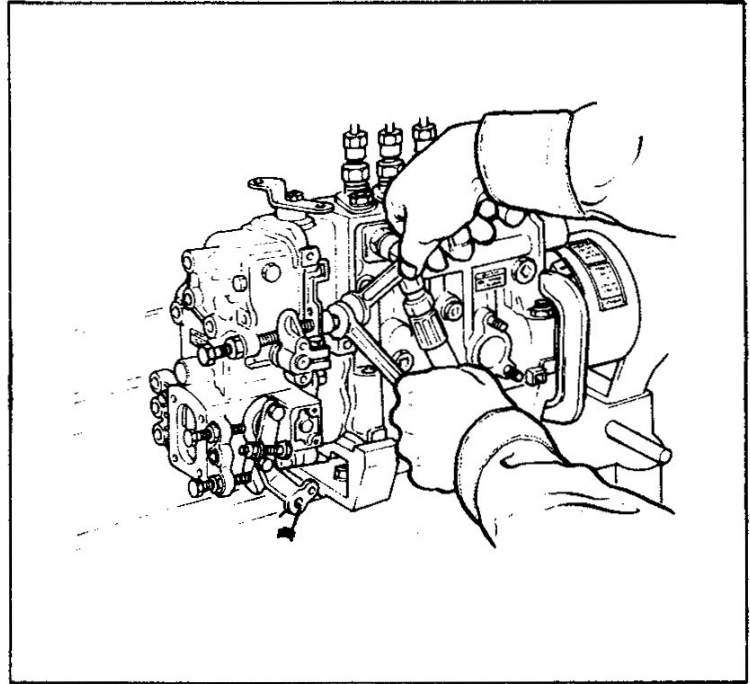

(e) Adjustment of idling

Adjust the pump speed to 800 to 1000rpm. In this condition, adjust the stopper bolt of the load control lever so that the control rod will be positioned at R_3 . With the load control lever fixed in this condition, lower the pump speed to N_c .

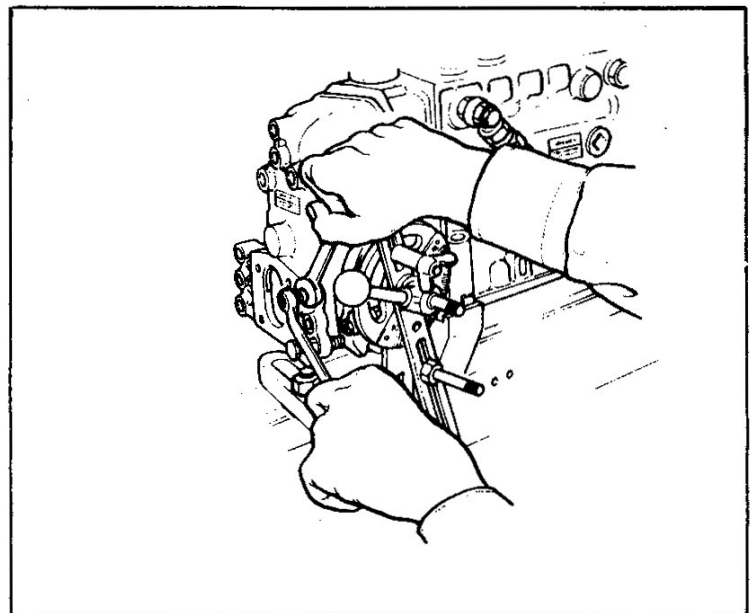

Adjust the idling spring so that when the pump speed is N_c , the control rod will be positioned at R_4 .

Check to see that the control rod is positioned at R_5 when the pump speed is N_d and at R_3 when the pump speed is N_e .

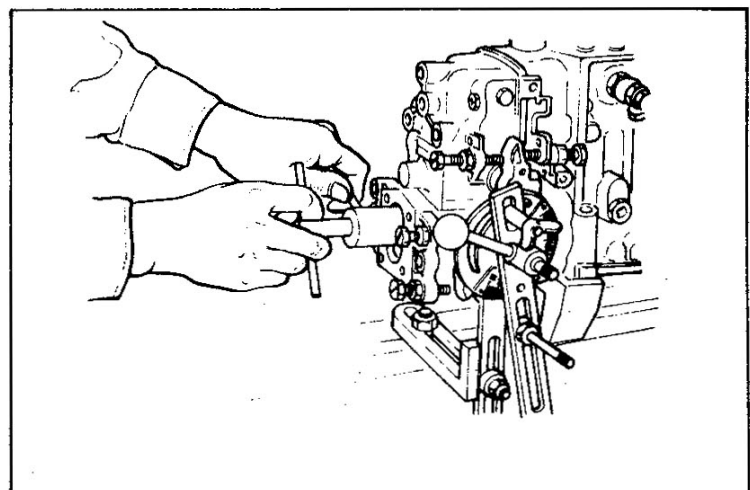

(f) Adjustment of damper spring

Operate the pump so that the control rod will be positioned at R_6 .

In this condition, tighten the damper spring until it touches the back surface of the control rod.

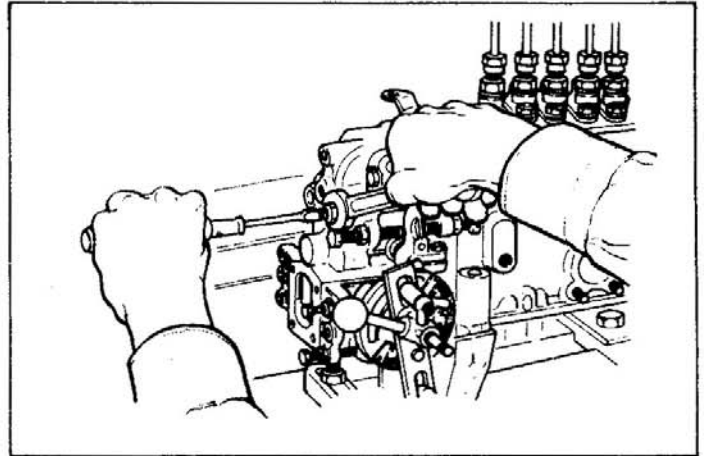

(g) Adjustment for adaptation to engine

After the governor adjustment has been completed, measure and adjust the total injection amount at the same lever angle as at the time of high speed control according to the adjustment standards.

(5) Feed Pump

The feed pump tests are as follows :

Test Item		Standard Value	Remarks
Air tightness test		0 cc/minute	When 196 kPa (2kgf/m ²) air pressure is applied
Delivery rate test	KE type	350cc/15secs	Pump 100rpm Test condition Fuel pipe $\varnothing 10 \times \varnothing 8 \times 2000$ mm Cam lift KE type.....6mm(D6AU) K type.....4mm(D6AZ) (Double cams)
	K type	530cc/15secs	
Pumping-up test		25 times or less.	No. of times feed pump is operated until it pumps up fuel by operating priming pump at 60 to 100 strokes/min. (Pumping-up lift 1m) Test condition Same as for delivery rate test

(6) SA Type Automatic Timer

Adjust the relation between pump speed and advance angle to match the specified automatic timer performance diagram.

The automatic timer performance diagram varies on different specifications.

Adjustment of Automatic Timer Advance Characteristics

Adjustment of the advance characteristics should be performed by adding or removing adjusting shims or replacing the spring.

Increase the shim thickness to reduce the advance angle.

Shim thickness(5 types)

0.1, 0.2, 0.5, 1.0, 1.5mm

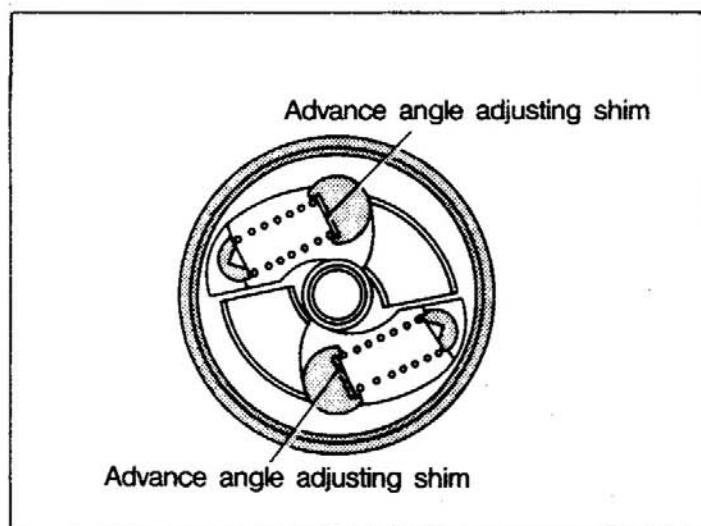

(7) SP Type Automatic Timer

Adjust the relation between pump speed and advance angle to match the specified automatic timer performance diagram.

The automatic timer performance diagram varies on different specifications.

Adjustment of Automatic Timer Advance Characteristics

Adjustment of the advance characteristics is performed by adding or removing adjusting shims or replacing the spring.

Increase the shim thickness to reduce the advance angle.

Shim thickness(6 types)

0.2, 0.4, 0.5, 0.6, 0.7, 1.0mm

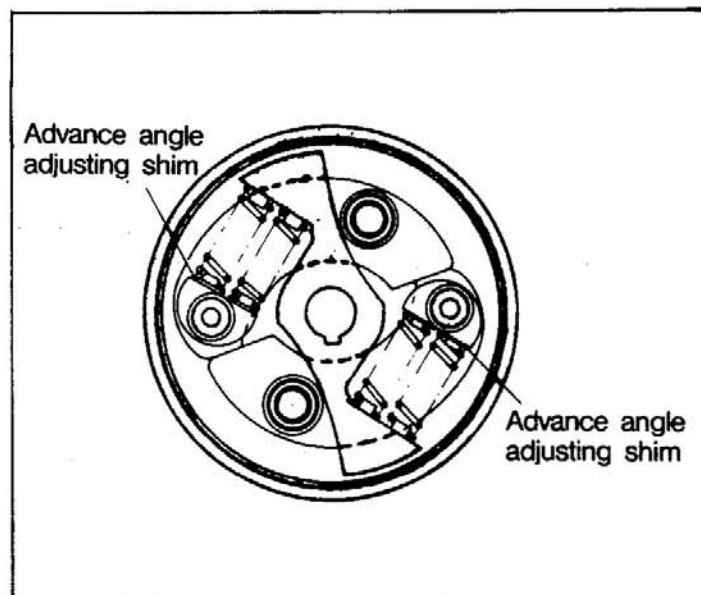

11-2 INJECTION NOZZLE

11-2-1 1-spring Nozzle

(1) Disassembly

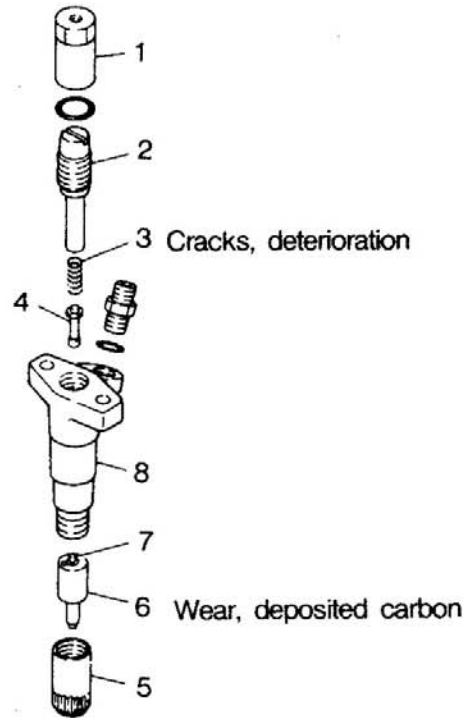

- 1 Cap nut
- 2 Adjusting screw
- 3 Spring
- 4 Push rod
- 5 Retaining nut
- 6 Nozzle
- 7 Needle valve
- 8 Nozzle holder

(2) Cleaning

After the nozzle has been cleaned in a cleaning solvent, remove the deposited carbon by the following procedures, using special tool(Nozzle Cleaning Tool).

NOTE : Make sure the combination of the nozzle and needle valve is not changed.

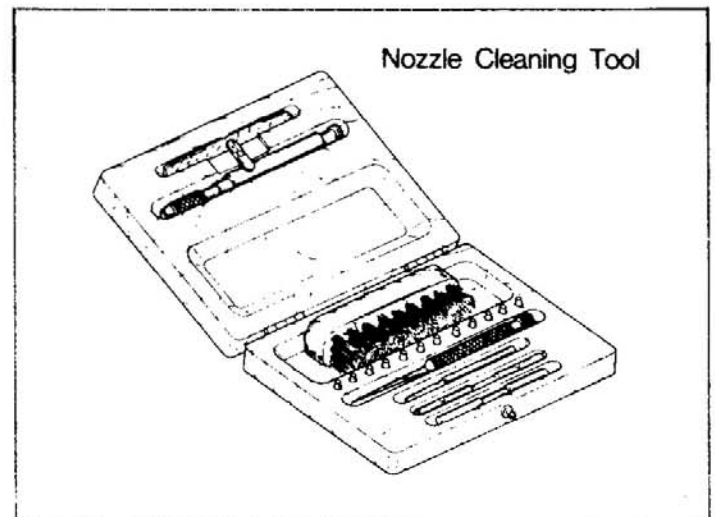

- (a) Remove the needle valve from the nozzle and clean the needle valve with a needle valve cleaning wood piece.

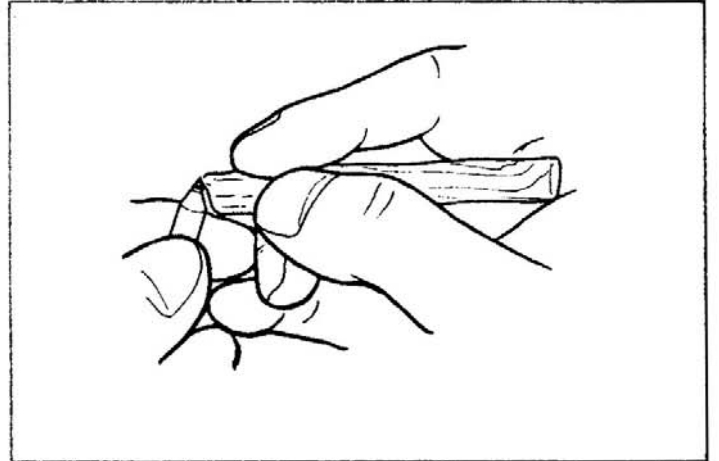

- (b) Pass a cleaning needle through the injection orifice of the nozzle, while turning the needle, to remove carbon.

First pass a cleaning needle 0.32 mm in diameter through the orifice and then pass a finishing needle 0.35 mm in diameter.

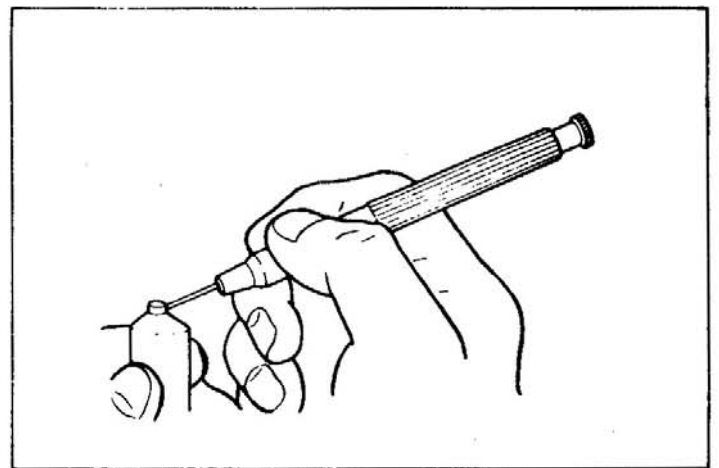

- (c) To remove burnt and hardened carbon, use FUSO Carbon Remover.

(3) Inspection

Clean and immerse the needle valve in gas oil, slide the needle valve, and check to see that it moves smoothly.

Then pull the needle valve approximately $\frac{1}{3}$ vertically and check to see that the needle valve falls down under its own weight.

If it does not fall, replace the nozzle.

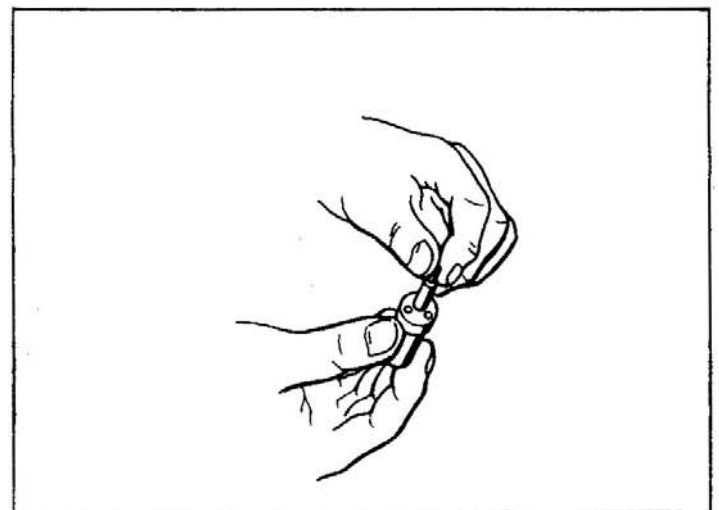

(4) Reassembly

NOTE : Be sure not to touch the sliding surface of the needle valve by hand.

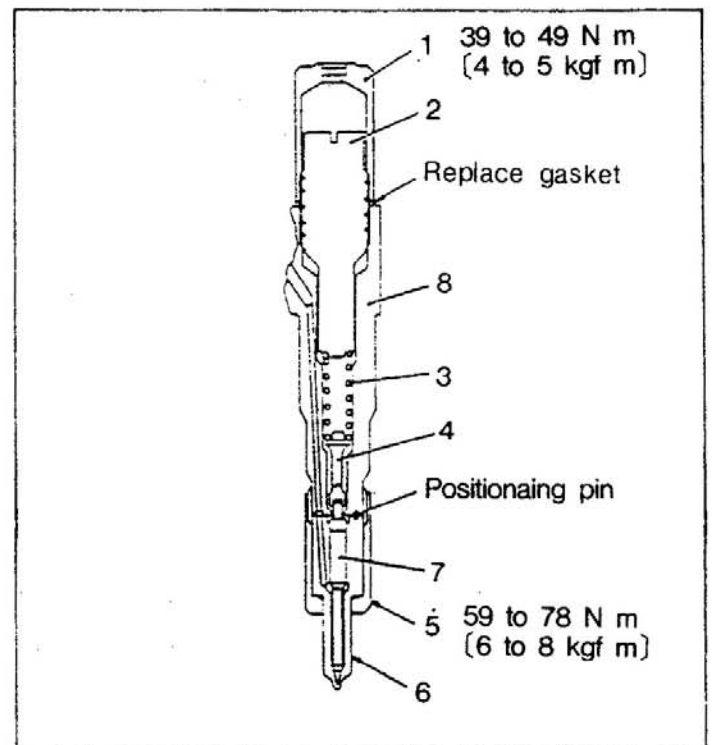

(5) Test and Adjustment

(a) Injection pressure

- 1) Remove the cap nut and mount the nozzle to a nozzle tester.
- 2) Loosen the adjusting screw. In that condition, let the nozzle inject two or three times to bleed the air.
- 3) Operate the lever of the nozzle tester at the specified speed. Adjust the injection pressure to the standard value with the adjusting screw.

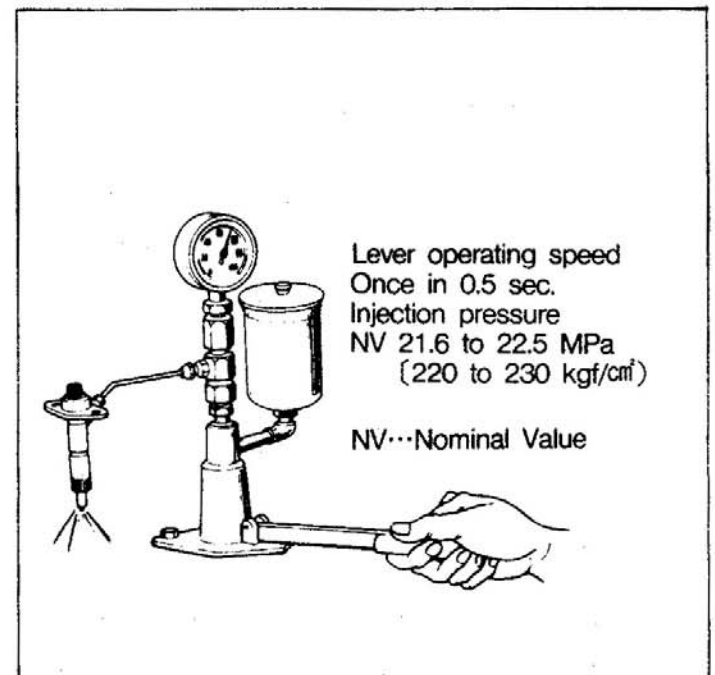

NOTE : Be sure not to touch the atomized fuel injected from the nozzle.

- 4) After the injection pressure has been adjusted, tighten the cap nut to the specified torque. At this time, insert a screwdriver through the hole in the cap nut to hold the adjusting screw in position and prevent it from rotating together.

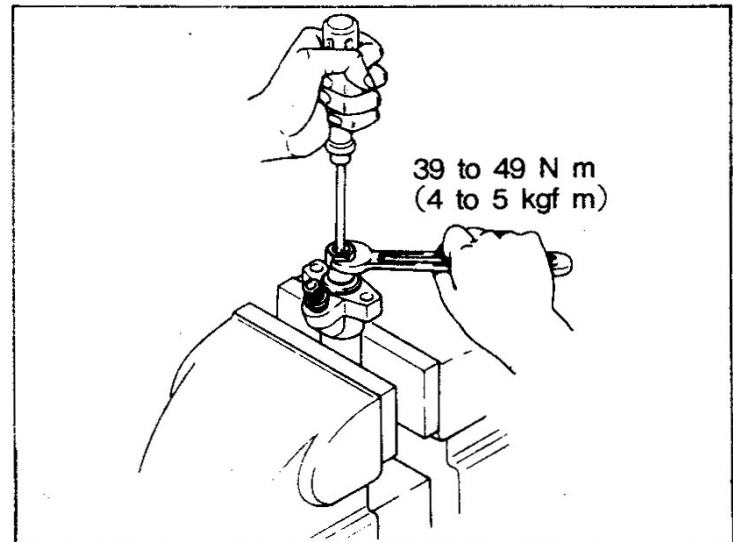

- 5) After the cap nut has been tightened, recheck whether the injection pressure is correct.

(b) Spray condition

When the injection pressure is adjusted by a nozzle tester, check for clogged injection orifices, spray condition, fuel leaks from the injection orifices, etc. at the same time. If defective, replace the nozzle.

① Good ② Good ③ Poor ④ Poor ⑤ Poor ⑥ Poor



Good spray

1. Evenly sprayed from four injection orifices
2. Even and symmetrical sprays

Poor spray

3. Asymmetrical sprays
4. Branches intermediately produced
5. Thin sprays
6. Irregular sprays

(c) Oil tightness test

Mount a nozzle adjusted to start in-

jection at $21.6 \begin{matrix} +0.98 \\ 0 \end{matrix}$ MPa

$(220 \begin{matrix} +10 \\ 0 \end{matrix} \text{ kgf/cm}^2)$ to a nozzle

tester and slowly increase the pres-

sure to the test pressure. Keep the condition and check for fuel leaks from the bottom of the nozzle. If there are no fuel leaks, the nozzle is good.

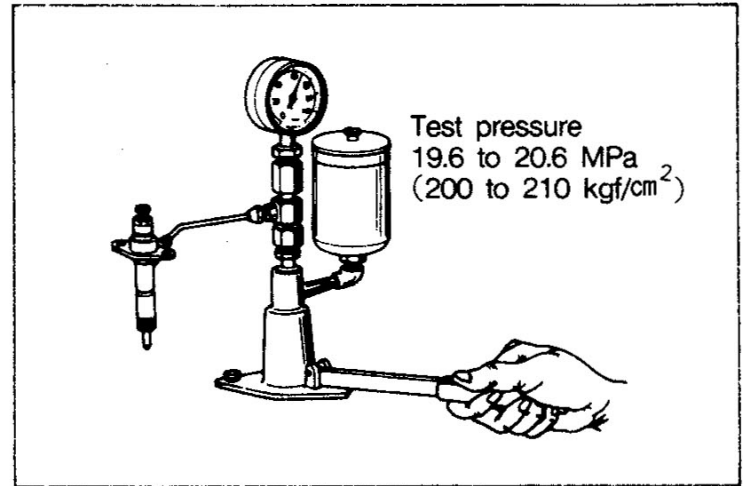

11-3 FUEL FILTER

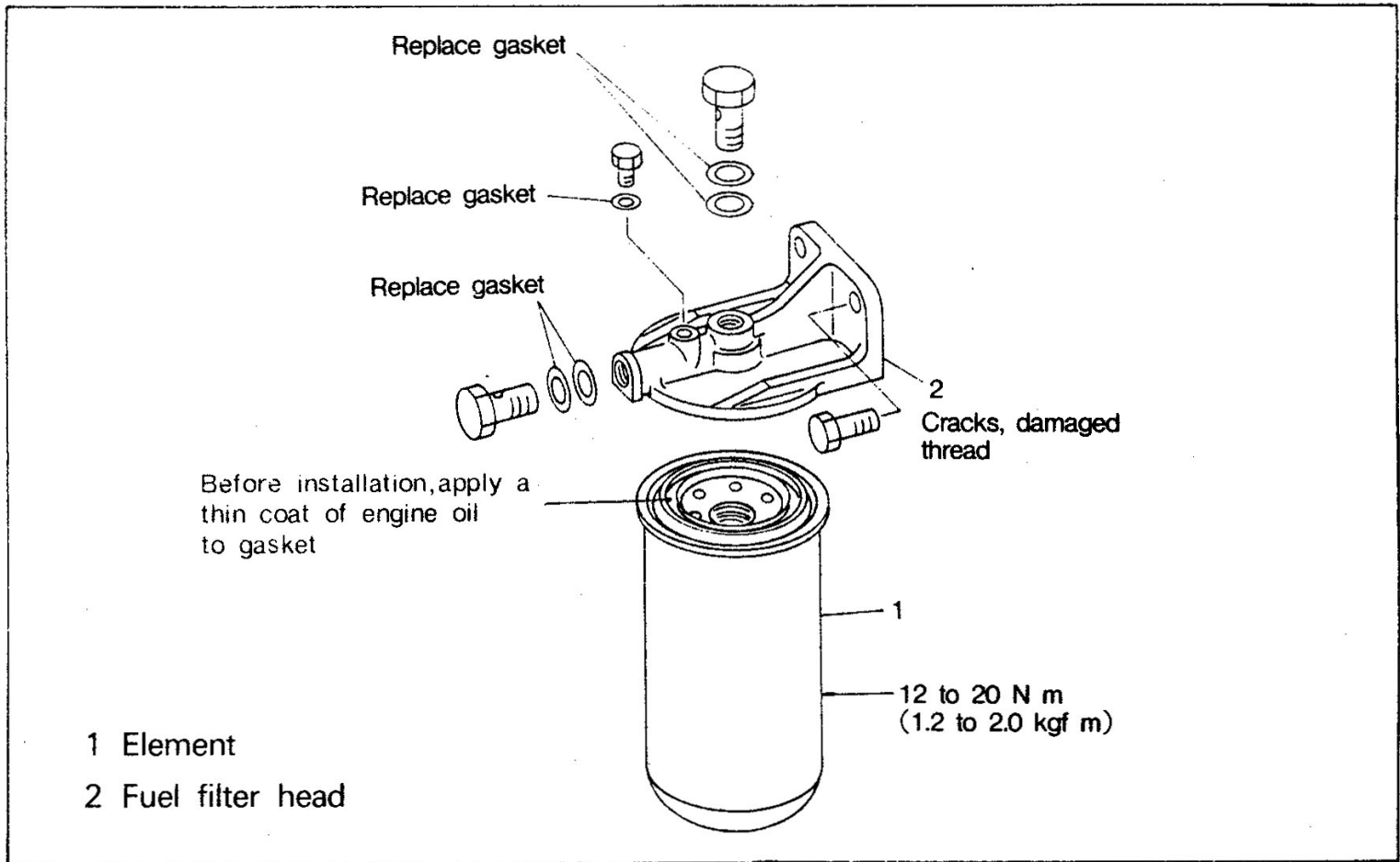

NOTE : 1. When removing the element, check for the gasket left behind on the head side.

2. To mount, apply a thin coat of engine oil to the gasket, and fully tighten by hand.

(Hand pressure equivalent to tightening torque of 12 to 20 N m or 1.2 to 2.0 kgf m).

3. After installation, start the engine and check for fuel leaks.

To remove the element, use special tool(Filter Wrench)

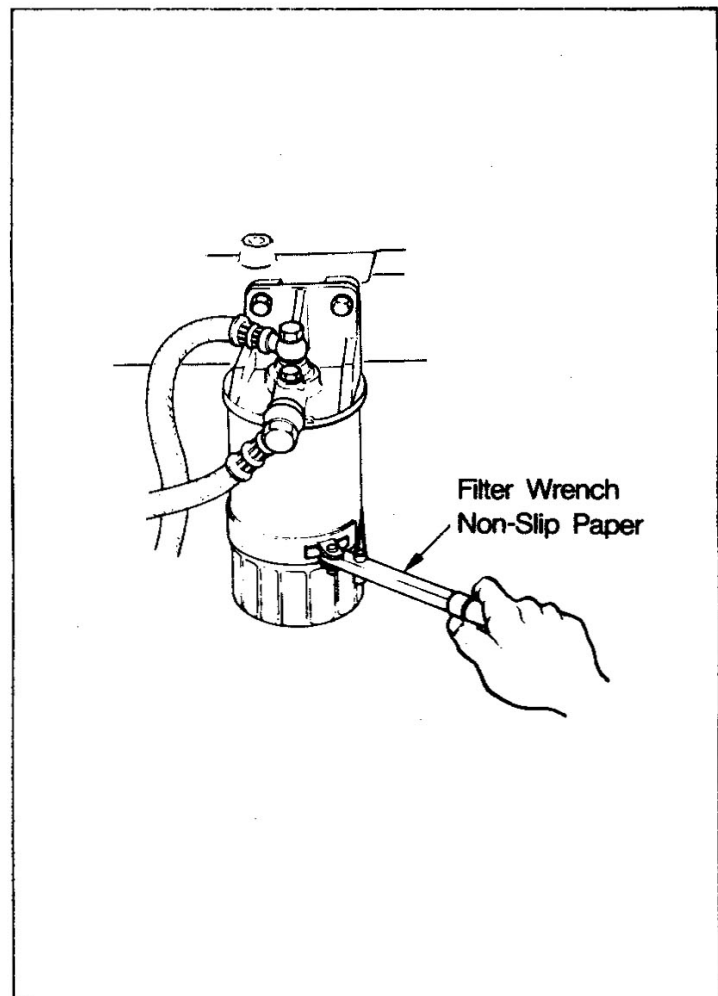

11-4 WATER SEPARATOR

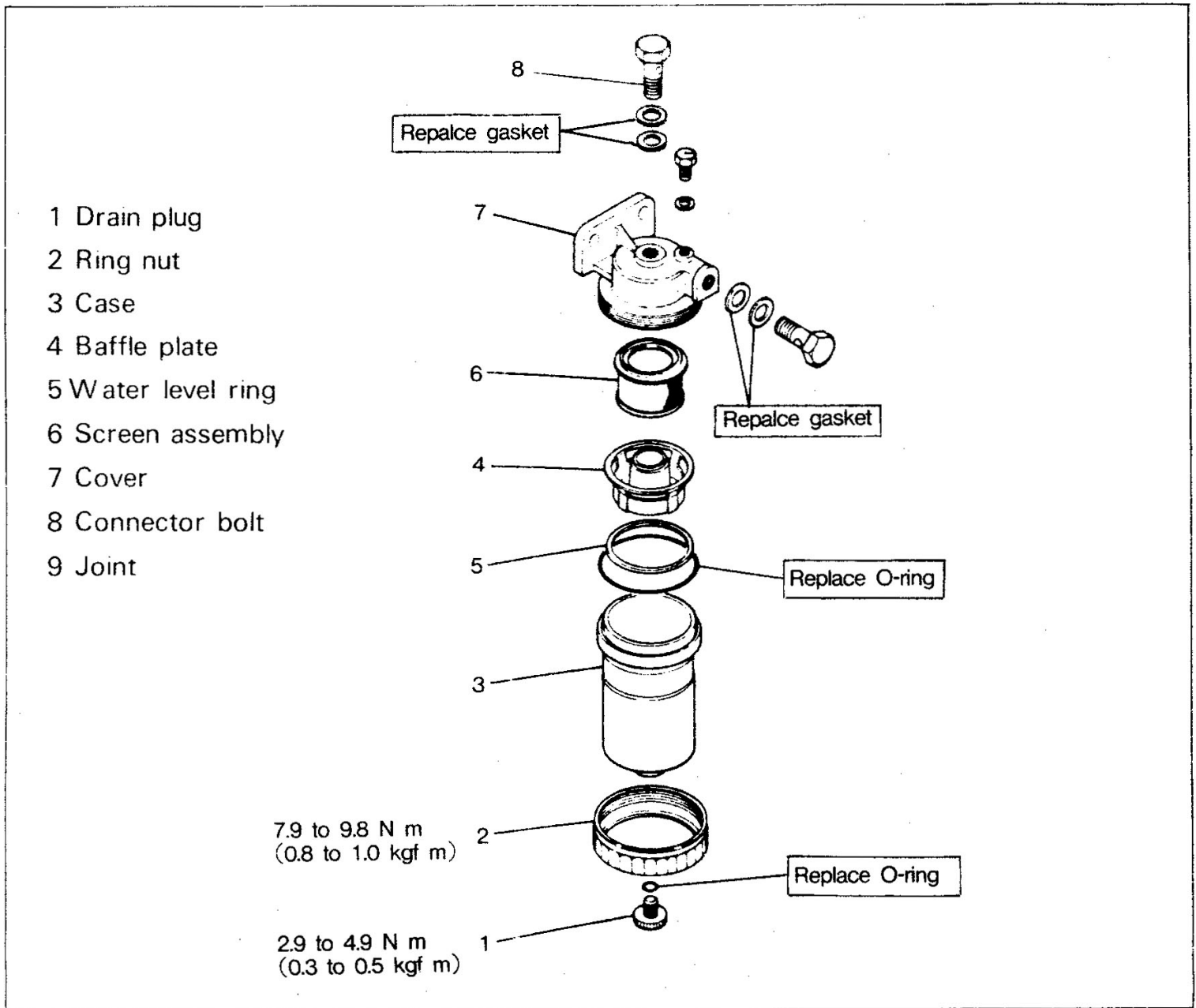

If the red float in the translucent case rises to the level of the red line marked on the outer circumference of the case, immediately loosen the drain plug to discharge water. It is not necessary to completely remove the drain plug, as water is discharged gradually through the groove of the loosened plug.

NOTE: After draining, tighten firmly the drain plug before bleeding the fuel system.

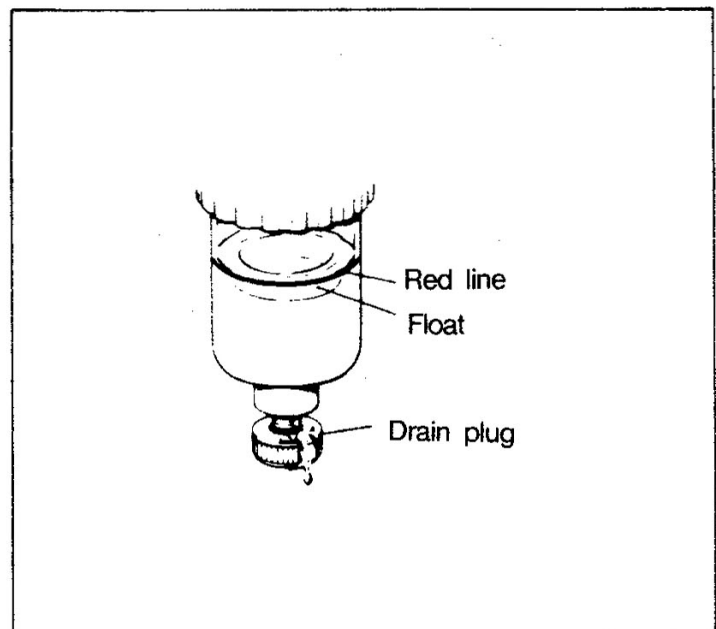

12-1 STARTER

(1) Disassembly

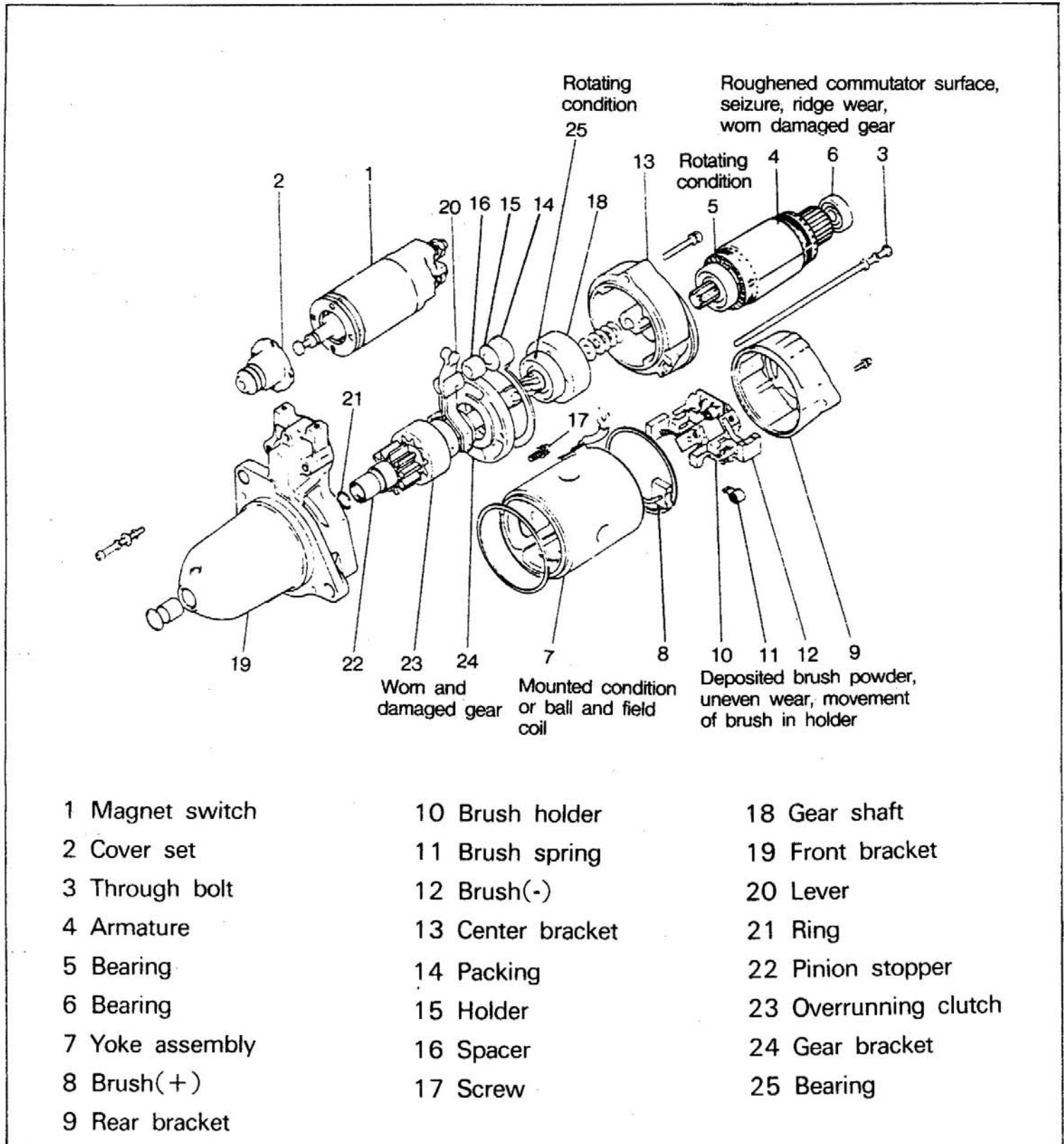

NOTE : 1. Do not remove the bearings located on each end of the armature unless defective.

2. To prevent misassembly, carefully confirm the assembly sequence and directions beforehand.

- (1) Hold a pipe-like tool on the pinion stopper and strike it with a hammer until the pinion stopper is loosened from the ring.

NOTE : If the pinion stopper cannot be removed, grind away the burr of the ring groove in the gear shaft.

- (2) If the bearing 25 of the gear shaft is defective, put a pin or bolt in each of the four holes(6mm in diameter) in the internal gear and press down the bearing out of position with a press.

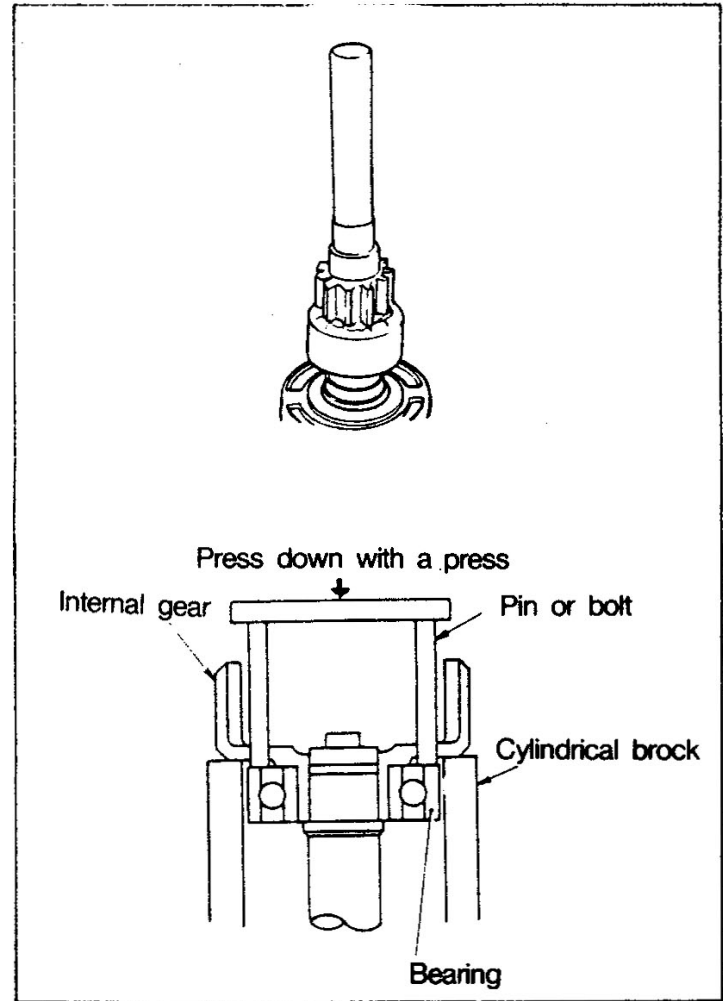

(2) Inspection

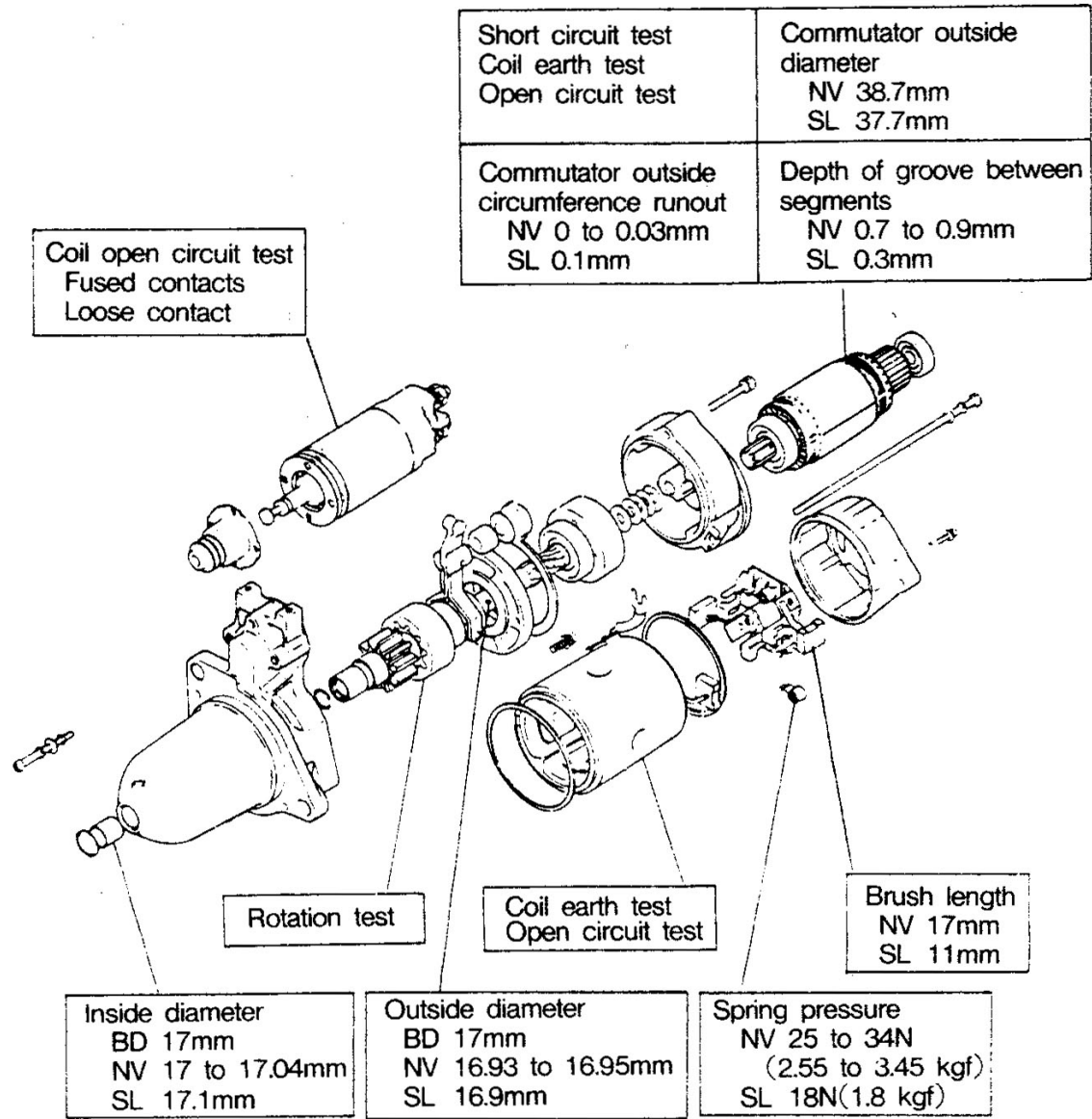

BD ... Basic Diameter
NV ... Nominal Value
SL ... Service Limit

(a) Armature

1) Coil short circuit test

Place the armature on a growler tester.

Hold a piece of iron in parallel with the armature and slowly turn the armature by hand.

If the iron piece is attracted or vibrates, it means that there is a short circuit. Replace the armature.

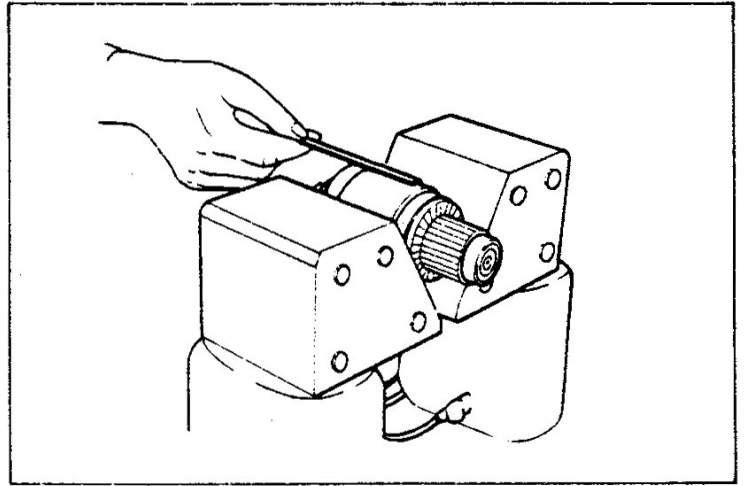

2) Coil earth test

Check to ensure that there is no continuity between the commutator and core.

If there is a continuity, it means that the coil is earthed. Replace the armature.

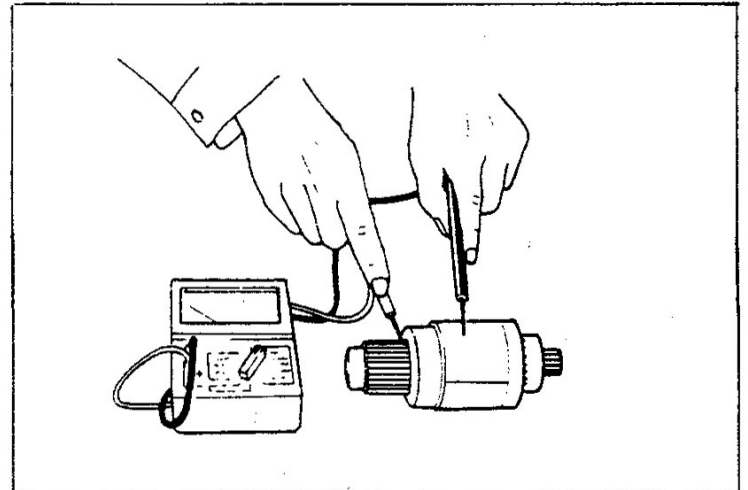

3) Inspection of commutator

a) Measure the runout of the commutator with a dial gauge.

If the runout is in excess of the repair limit, correct, while making sure that the service limit of the outside diameter is not exceeded.

If the commutator surface is rough or shows ridge wear, correct with sandpaper (No. 300 to 500).

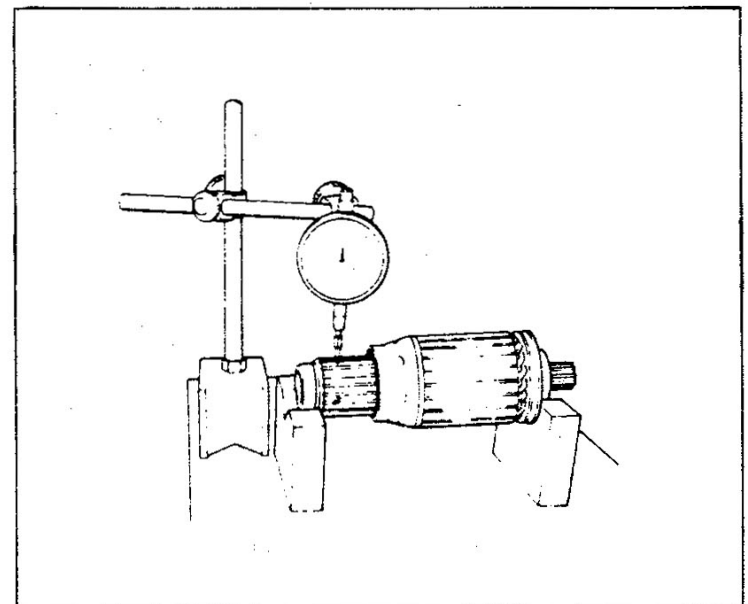

b) Measure the outside diameter of the commutator. If the outside diameter is less than the service limit, replace the armature.

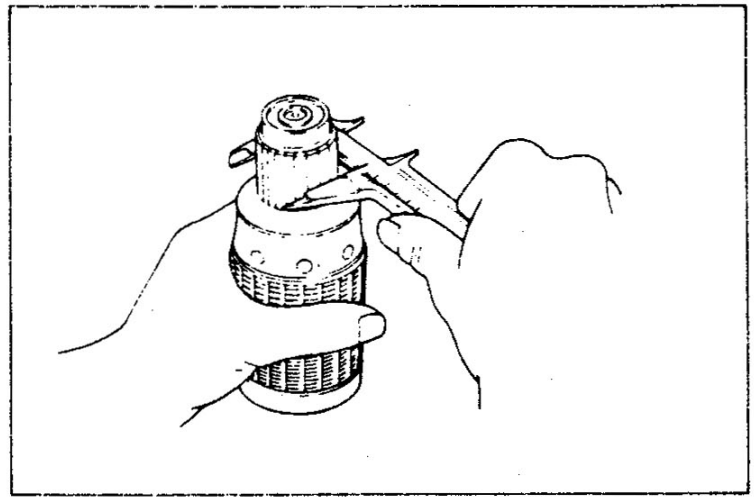

c) Measure the depth of groove between segments. If the depth is less than the repair limit, correct.

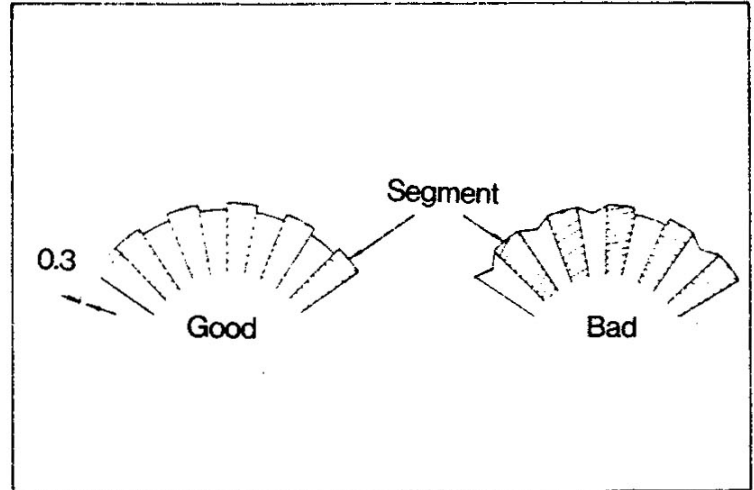

(b) Field coil

1) Coil open circuit test

Check to ensure that there is continuity between the terminal lead and brush(+).

If there is no continuity, it means that there is an open circuit. Replace the yoke assembly.

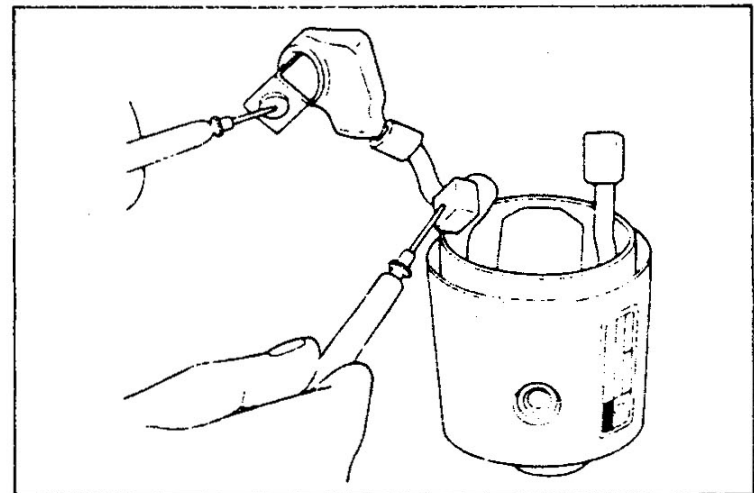

2) Coil earth test

Check to ensure that there is no continuity between the yoke and brush(+).

If there is a continuity, the coil is earthed. Check for poor insulation. If correction is impossible, replace the yoke assembly.

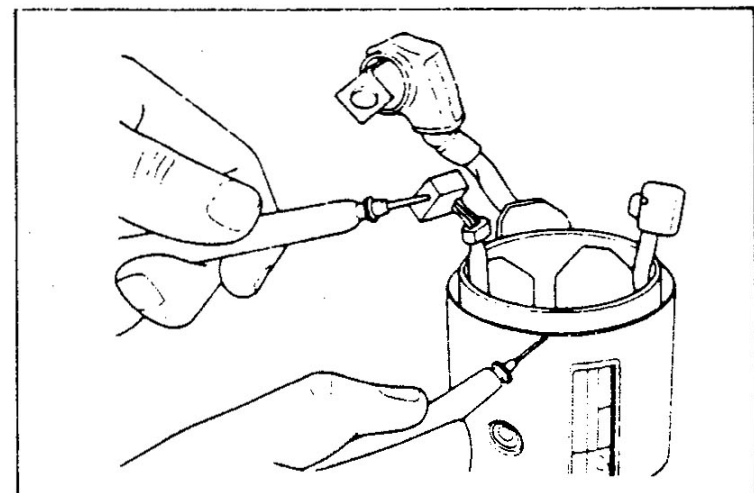

(c) Brush and brush holder

1) Wear of brush

Measure the length of brush. If the length is less than the service limit, replace the brush.

If the brush is unevenly worn or has a rough contacting surface, correct with sandpaper (No. 300 to 500).

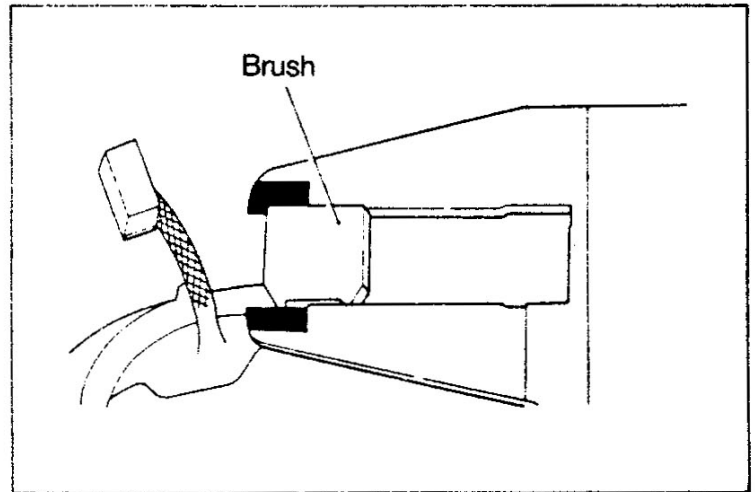

2) Brush spring pressure

Measure the installed load of brush spring. Using a new brush, read the load at the moment the spring leaves the brush.

If the spring pressure is less than the service limit, replace the spring.

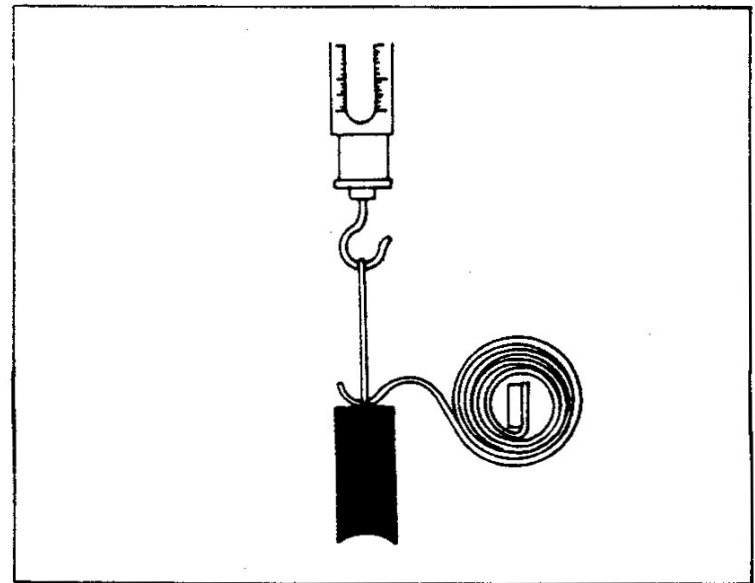

3) Brush holder insulation test

Check to ensure that there is no continuity between the (+) side brush holder and (-) side holder plate.

If there is a continuity, replace the brush holder.

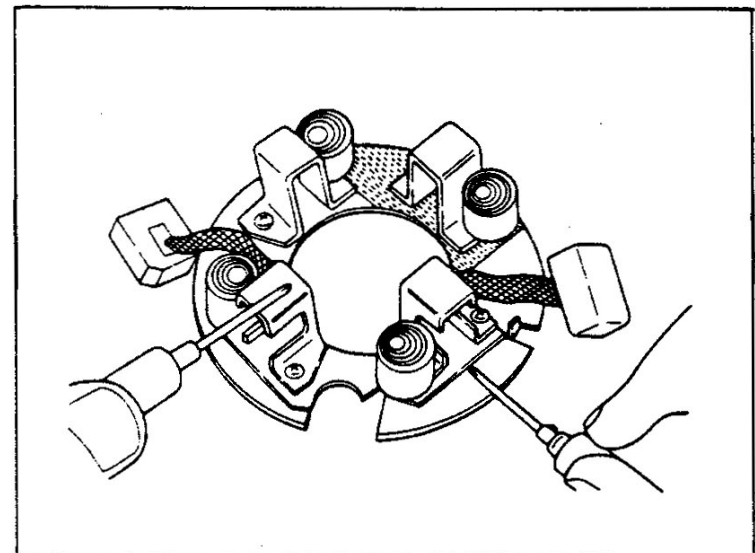

(d) Overrunning clutch

Check to ensure that the pinion rotates smoothly when turned in the drive direction (clockwise) and locks when turned in the opposite direction (counterclockwise).

If the pinion does not rotate properly, replace the overrunning clutch.

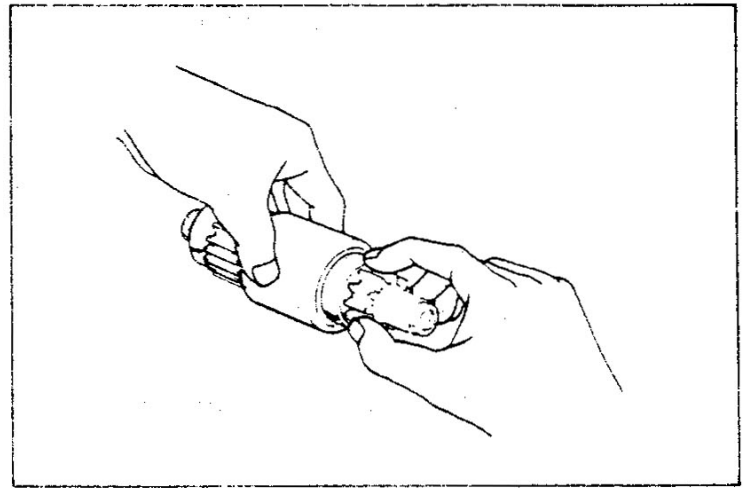

(e) Measure the outside diameter of gear shaft and the inside diameter of sleeve bearing in the front bracket.

If the readings are the service limits, replace.

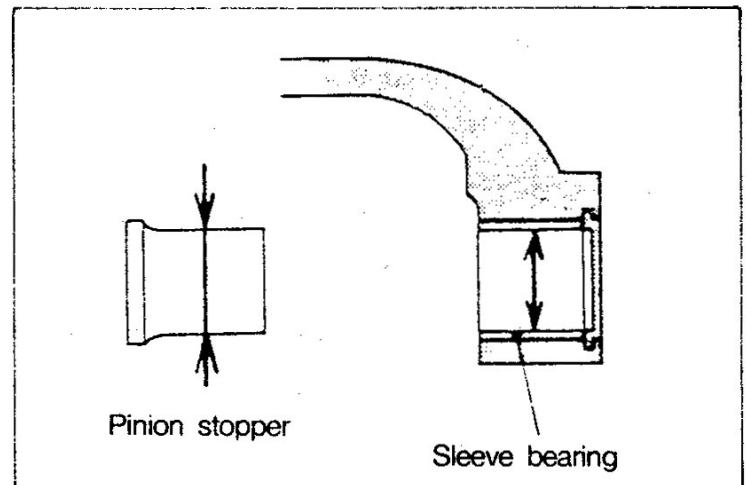

(f) Magnet switch

Perform the following continuity tests. If defective, replace the magnet switch.

1) Coil open circuit test

Check to see that there is continuity between S and M terminals (resistance value 1Ω or less) and between the S terminals and earth (resistance value 2Ω or less).

2) Melted contact check

Check to see that there is no continuity between B and M terminals.

3) Loose contact check

Check to see that there is a little voltage drop across the contacts. If there is a large voltage drop, the contacts are defective.

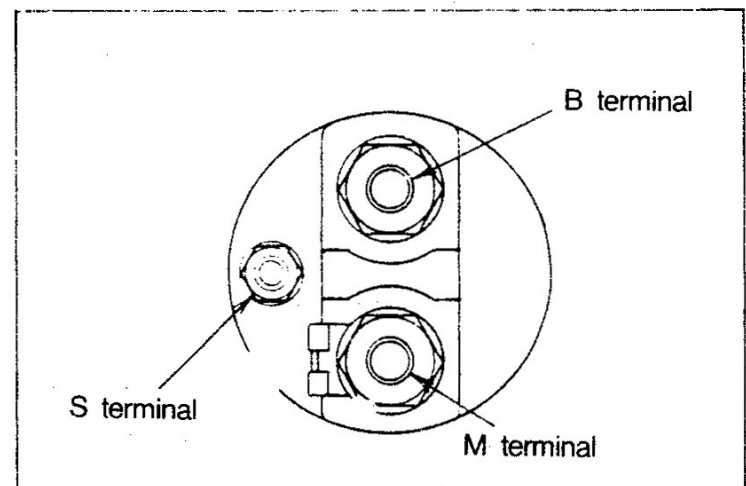

(3) Reassembly

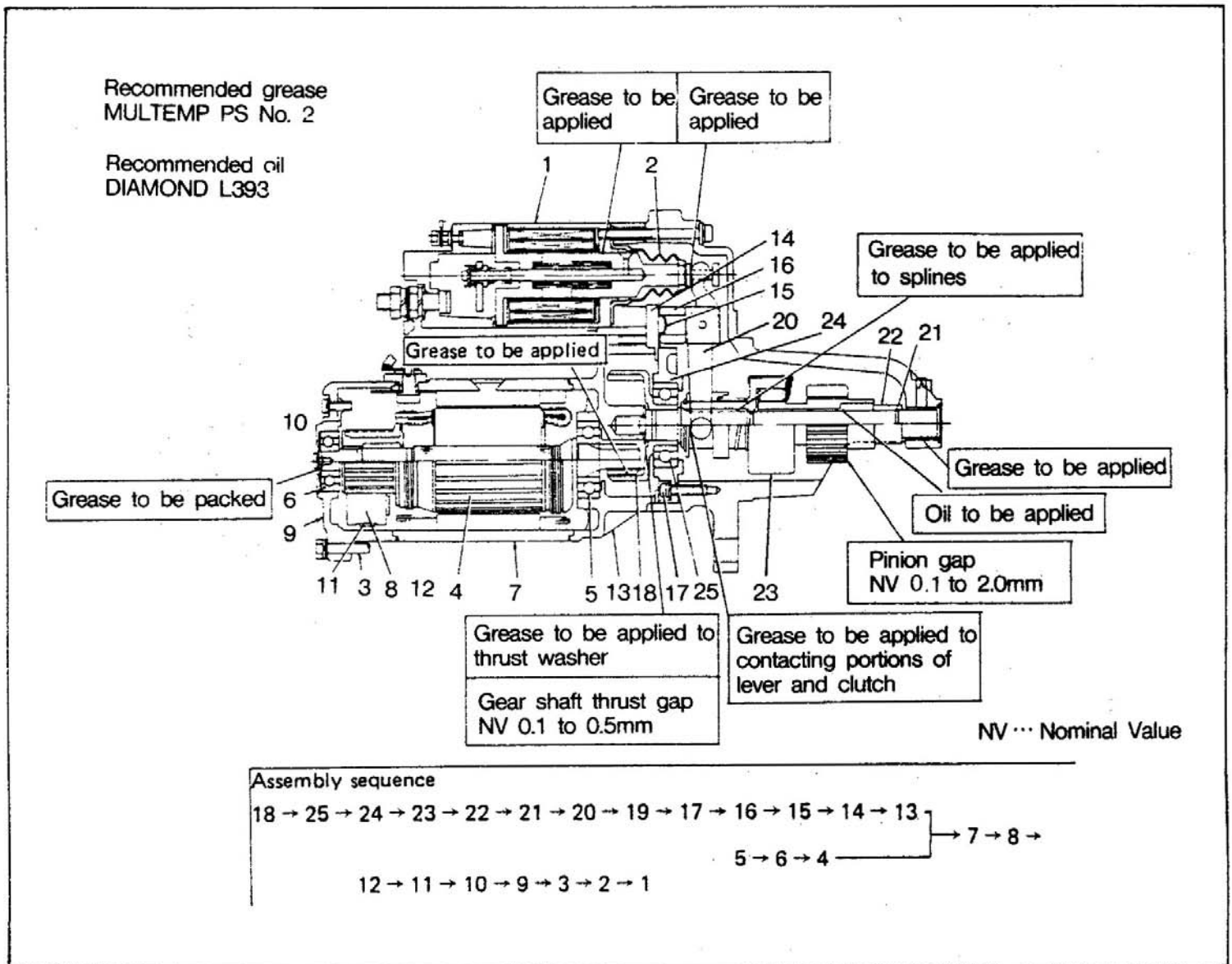

NOTE : 1. When the lever is installed, pay attention to its installing direction.

2. The yoke assembly and center bracket have a positioning notch and projection.

3. The armature thrust gap is a no-adjustment type.

(a) Install the following parts on the gear shaft 18.

- 25 Bearing
- 24 Gear bracket
- 23 Overrunning clutch
- 22 Pinion stopper
- 21 Ring

For installation of the pinion stopper and ring, install the pinion stopper, secure the ring in the ring groove

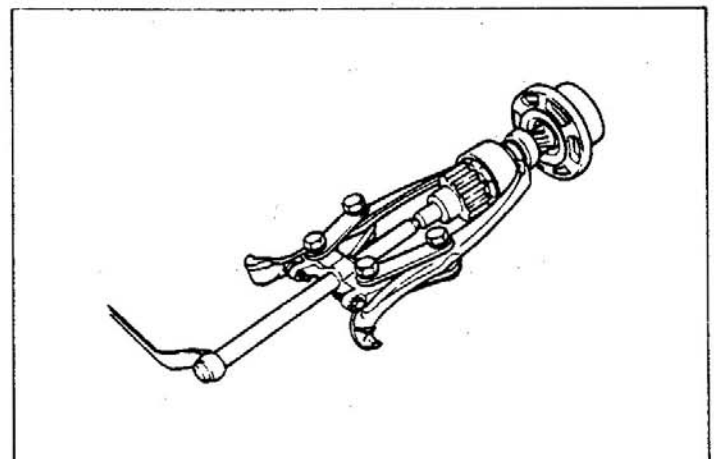

of the gear shaft, and then secure both by drawing the overrunning clutch tightly against them.

- (b) Choose adjusting washers to make sure that the thrust gap of the gear shaft falls within the nominal value, and install the packing 14, bearings 5 and 6 put together as an assembly, armature 4 and center bracket 13.

To measure the thrust gap, temporarily assemble the center bracket and determine the gap on the basis of a difference in the dimension A. Thickness of adjusting washers 0.2mm and 1.0mm

NOTE : If the thrust gap is measured with the packing installed, an accurate reading cannot be taken because of the elasticity of the packing.

- (c) Install the cover set 2 and magnet switch 1.

Measure the pinion gap and add or remove washers on the magnet switch assembly mounting surface so that the gap will conform to the nominal value.

To measure the pinion gap, make connections as shown in illustration at right.

Close the switches K_1 and K_2 . If the

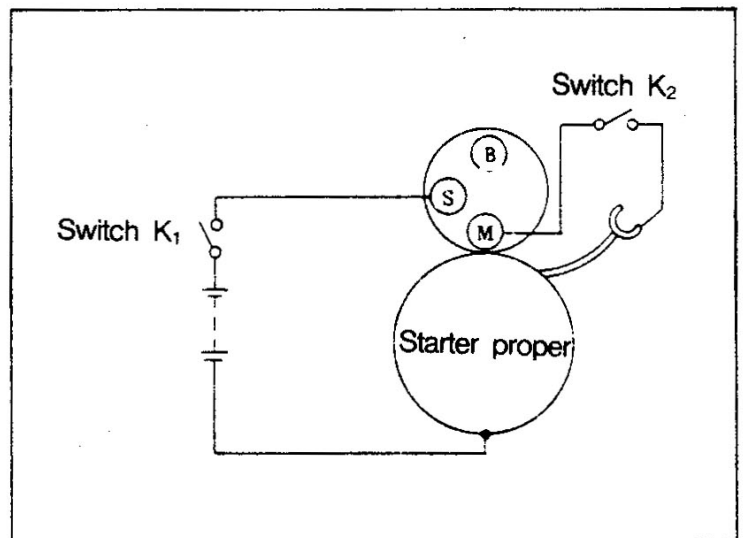
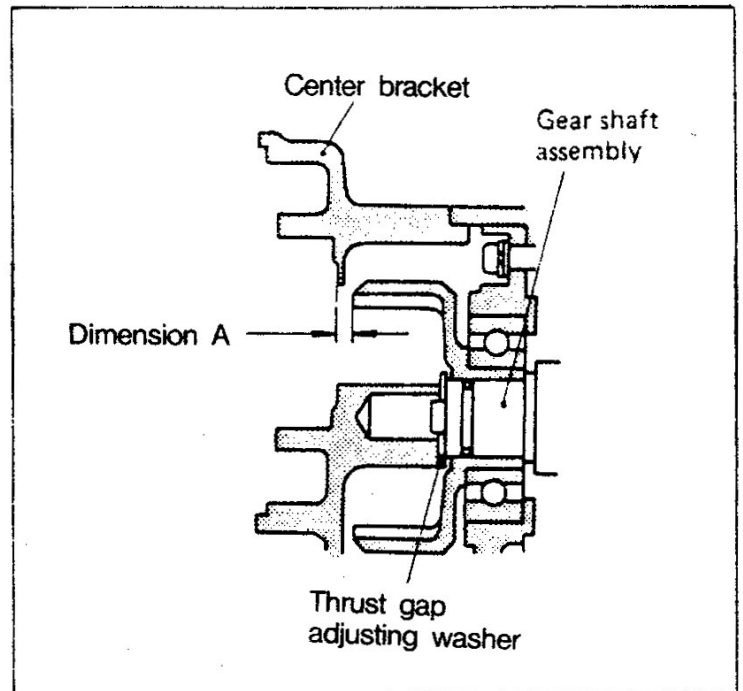

pinion comes out rotating, open the switch K_2 to stop rotation of the pinion.

In this condition, lightly push the pinion toward the armature, and the amount the pinion is moved in the axial direction is the pinion gap.

NOTE : 1. Do not close the switch K_2 for more than 30 seconds. If the switch is closed for a longer period, heat damage to the coil and lead could result.

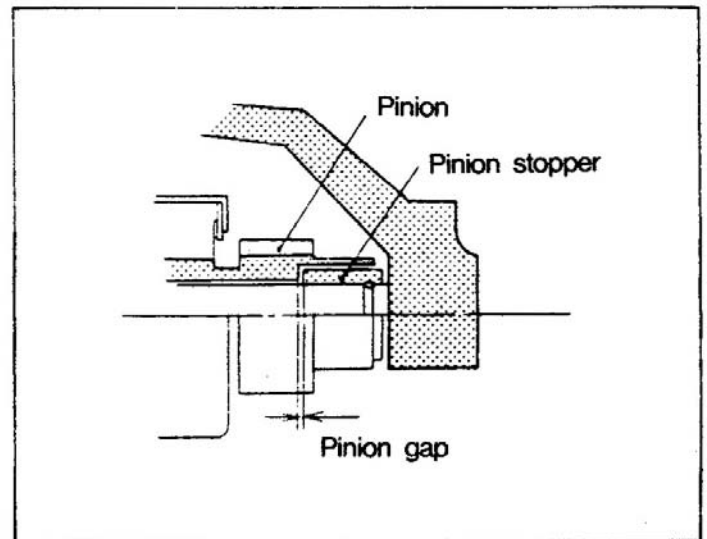

2. The pinion is pushed by a spring in the direction that it moves out. Even if it is pushed back by hand, the pinion will return when released.

(4) Test

No-load characteristics	Voltage	23V
	Current	110A or less
	Rotating speed	3100rpm or more
Bound characteristics	Voltage	8V
	Current	1400A or less
	Torque	98N(10kgf) or more
Magnet switch operating voltage		16V or less

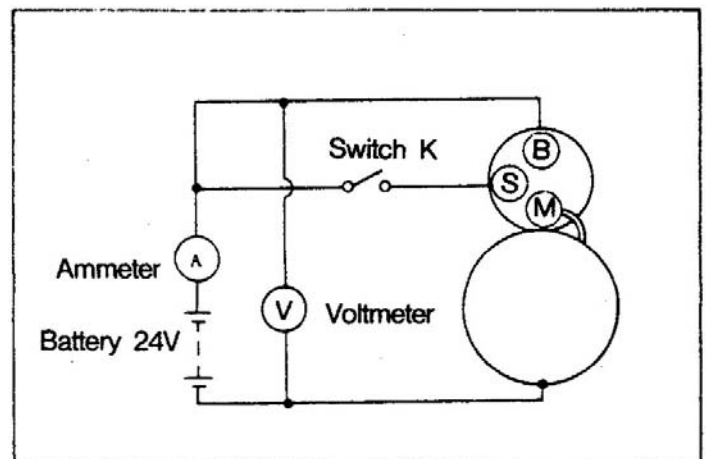

Large current flows but rotating speed is low. (No torque)	(1) Sleeve bearing and ball bearing short of oil or contaminated (2) Armature and yoke pole portion rubbing (3) Armature coil and yoke field coil earthed (4) Armature coil short-circuited
Large current flows but no rotation occurs.	(1) Magnet switch earthed (2) Armature coil and yoke field coil earthed (3) Sleeve bearing and ball bearing seized
No current flows and no rotation occurs.	(1) Open circuit in armature coil and yoke field coil (2) Open circuit in brush (3) Commutator contaminated or in loose contact due to high mica, etc.
Small current flows and rotating speed is low.	Contacting portions of yoke field coil in loose contact
Large current flows and rotating speed is high.	Short circuit in yoke field coil

NOTE : 1. Use as thick wires as possible for wiring and tighten all terminals firmly.

2. Since the starter has a built-in reduction gear, it produces high rotating sound at no load.
3. If the starter is operated for a long period, the battery will run down and the rotating speed will fall. Operate the starter for 10 to 15 seconds and stop it for 10 to 15 seconds, and thereafter repeat this sequence.

12-2 STARTER RELAY

- (1) Check for continuity between the "SW" and "L" terminals and check to ensure that the coil resistance is up to specification.

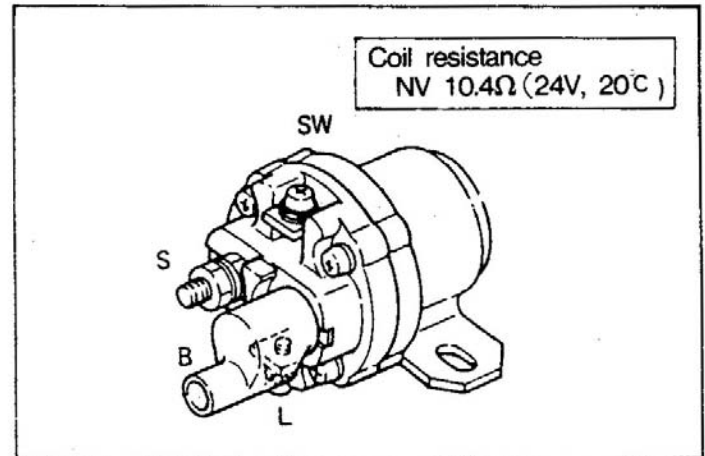

- (2) Check to ensure that when the battery voltage(24V) is applied across the "SW" and "L" terminals, there is continuity between the "B" and "S" terminals.

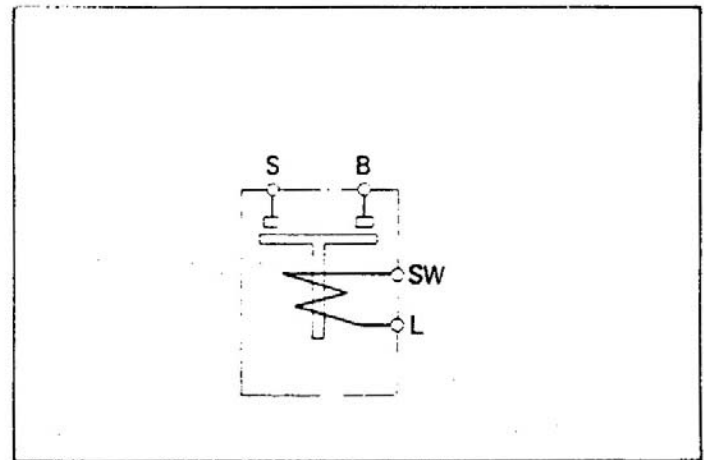

12-3 ALTERNATOR

12-3-1 Alternator Handling Precautions

When servicing the alternator, pay attention to the following.

- (1) If the polarity of the battery is reversed when connections are made, large current will flow from the battery to the alternator, causing damage to the diode and the IC regulator.
- (2) Do not disconnect the battery terminal connections while the engine is running. Otherwise, a surge voltage will be generated, causing deterioration of the diode and the regulator.
- (3) Do not use a high voltage tester such as megger to test the alternator as it could cause damage to the diode and the regulator.

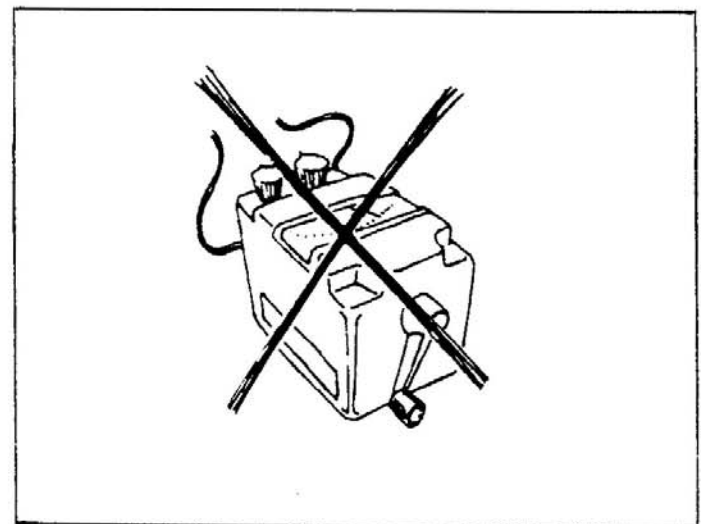
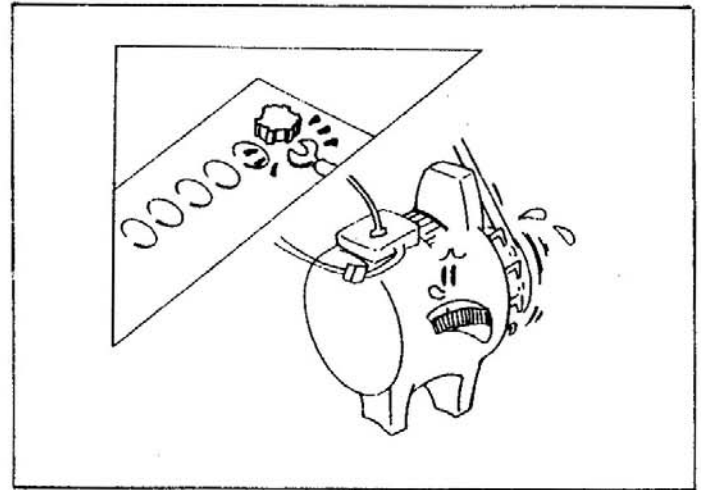
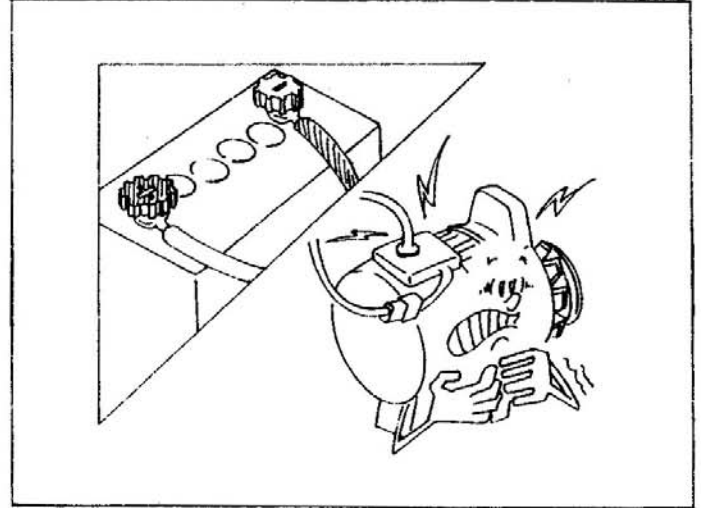

- (4) When a steam cleaner is used, take care to prevent direct exposure of the alternator to the steam.

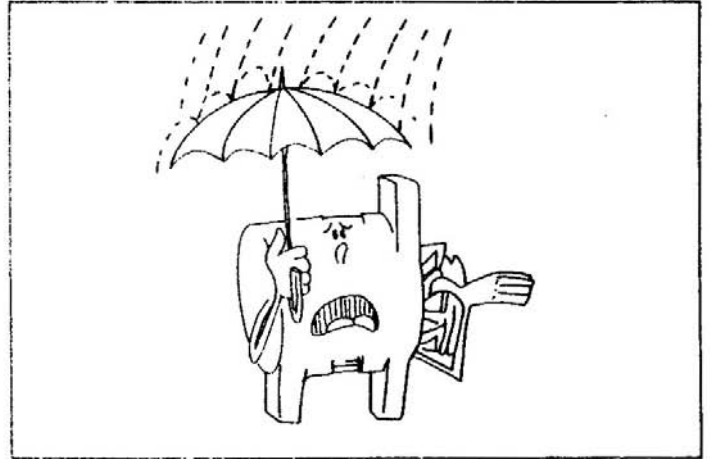

- (5) Operation of the alternator with the terminals shorted will result in damage to the diodes.

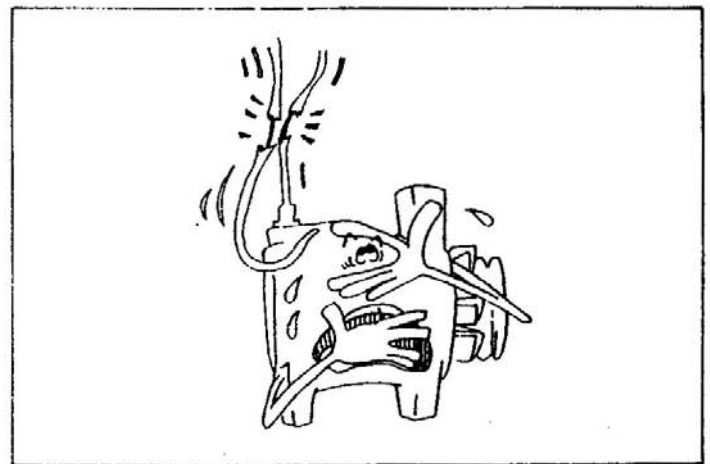

- (6) When the battery is to be quick-charged with a quick charger, be sure to disconnect the battery terminal connections beforehand. Otherwise, the diode and the regulator would be damaged.

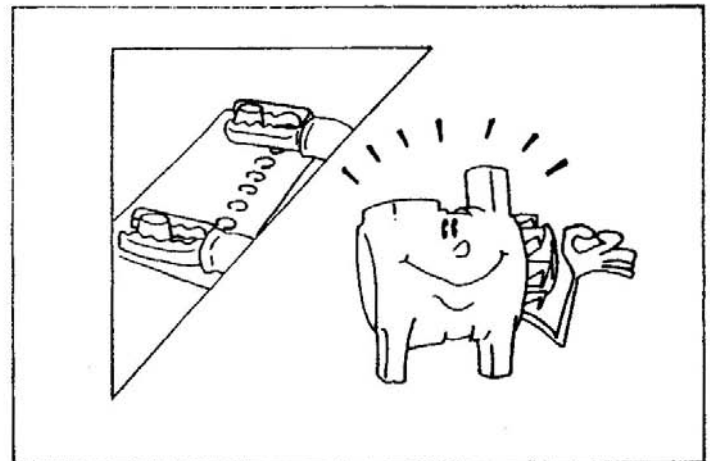

12-3-2 40A Alternator

(1) Disassembly

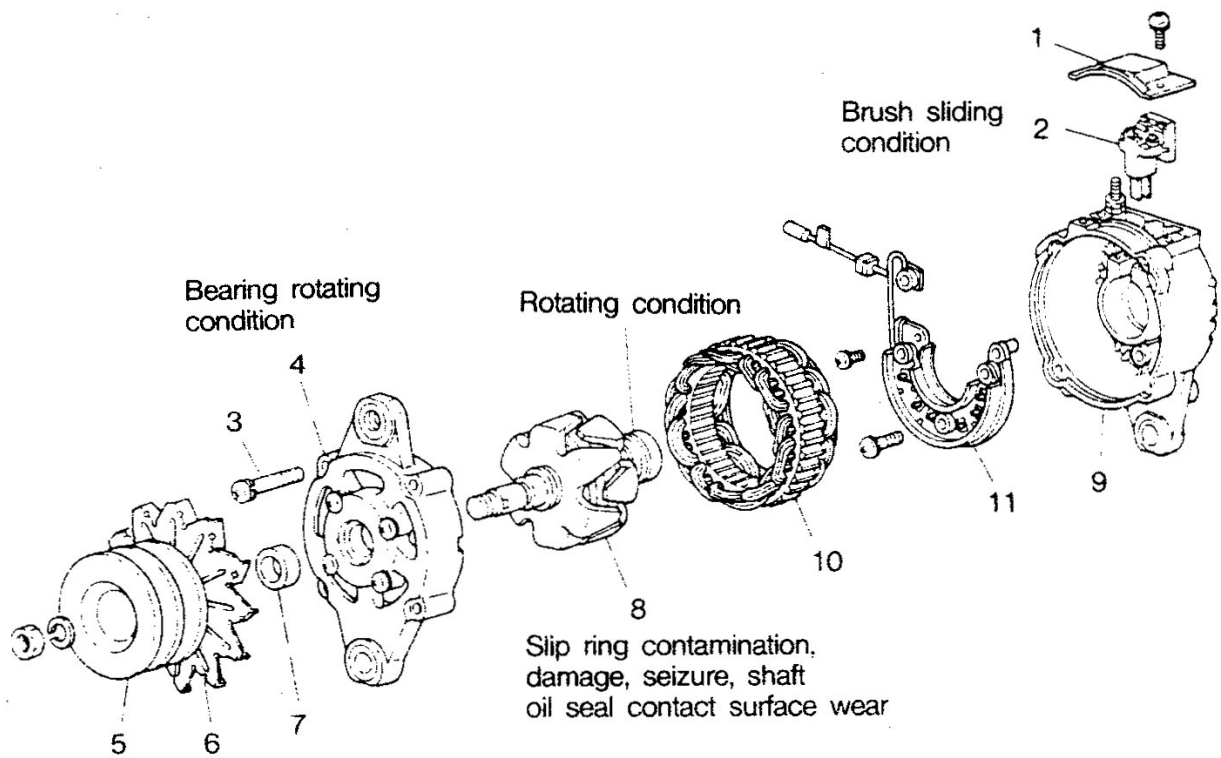

- | | | |
|----------------------|----------|----------------|
| 1 Cover | 5 Pulley | 9 Rear bracket |
| 2 Regulator assembly | 6 Fan | 10 Stator |
| 3 Through bolt | 7 Spacer | 11 Rectifier |
| 4 Front bracket | 8 Rotor | |

NOTE : 1. If disassembly is continued without removing the regulator assembly, the brush will be damaged when removing the rotor.

2. Do not remove the oil seal unless it is defective.

(a) Remove the through bolt 3 and separate the assembly into the front bracket and the rear bracket as illustrated.

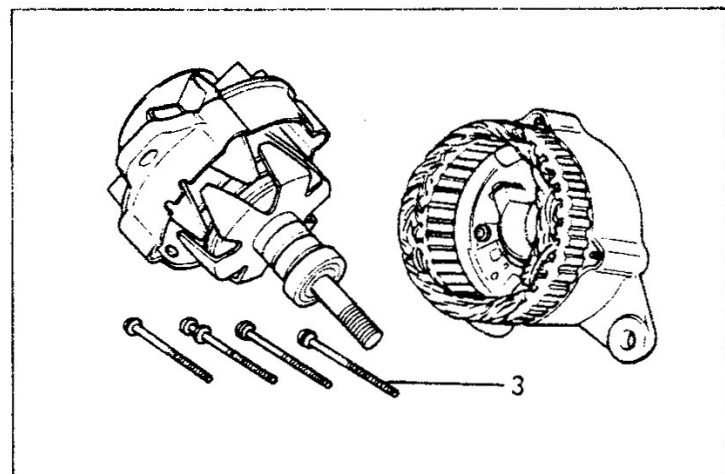

- (b) Unsolder the stator coil leads and remove the stator 10 from the rear bracket 9.

NOTE : When unsoldering, operate the soldering iron quickly (within 5 seconds or so).

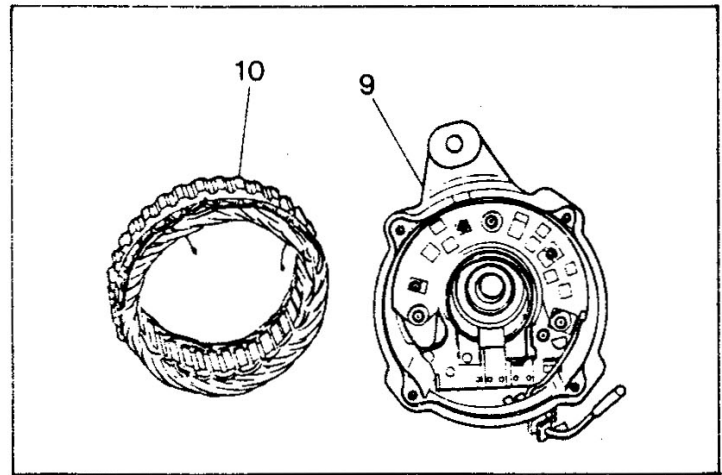

(2) Inspection

NV ... Nominal Value
SL ... Service Limit

Earth test	
Slip ring O.D.	Field coil resistance
NV 41mm	NV 10Ω
SL 40.4mm	

Brush length
NV 23mm
SL 8mm
Brush spring pressure
NV 3.7N(380 gf)
SL 2N(200 gf)

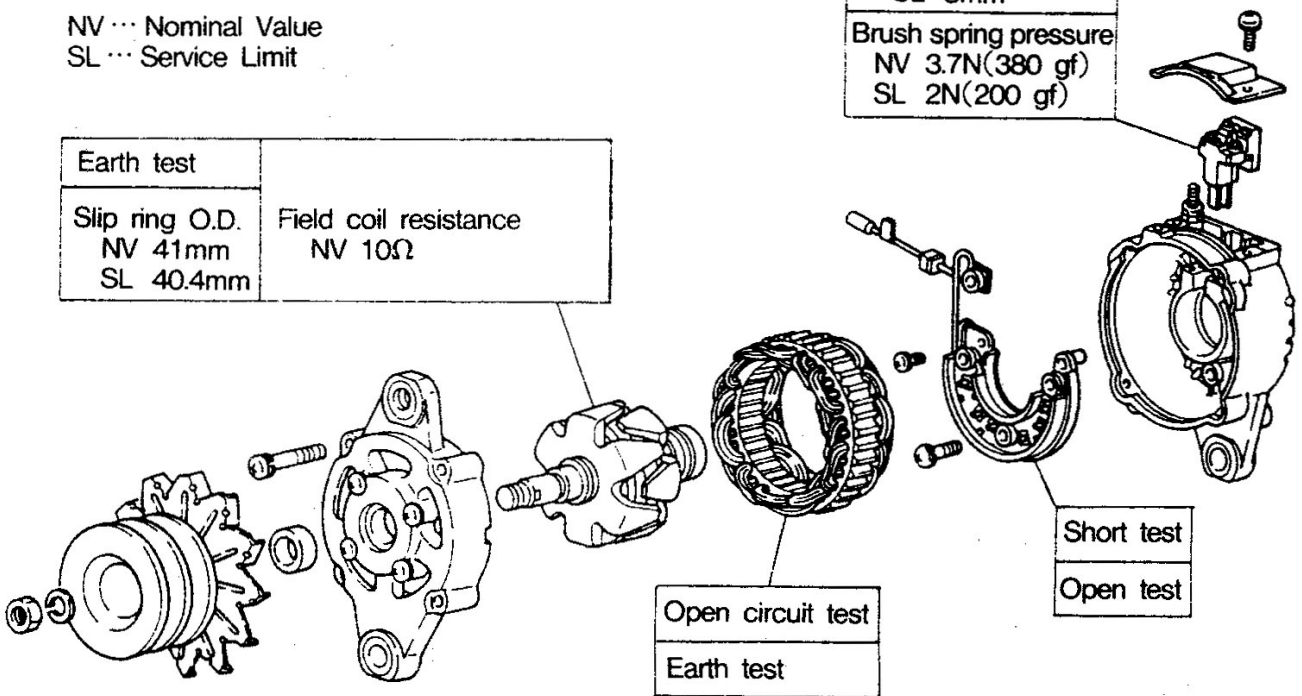

(a) Stator

- 1) Check that there is continuity between stator leads.

If not, replace the stator as leads are broken.

- 2) Check that there is no continuity between the stator leads and core.

If there is continuity, replace the stator as it is earthed.

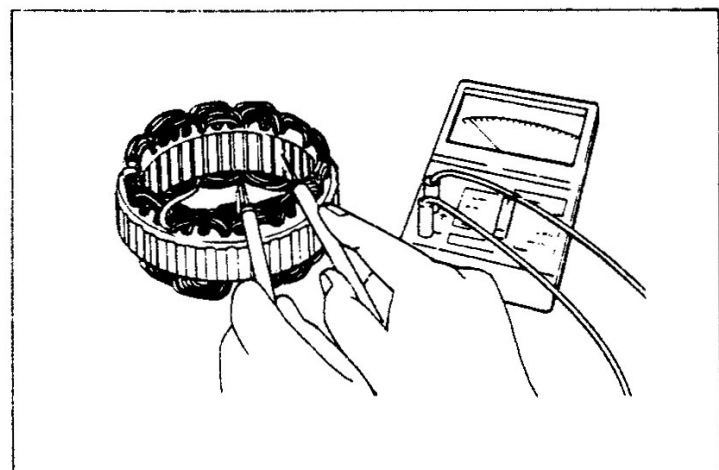

(b) Rotor

- 1) Check that there is no continuity between the slip ring and the core. If there is continuity, replace the rotor.

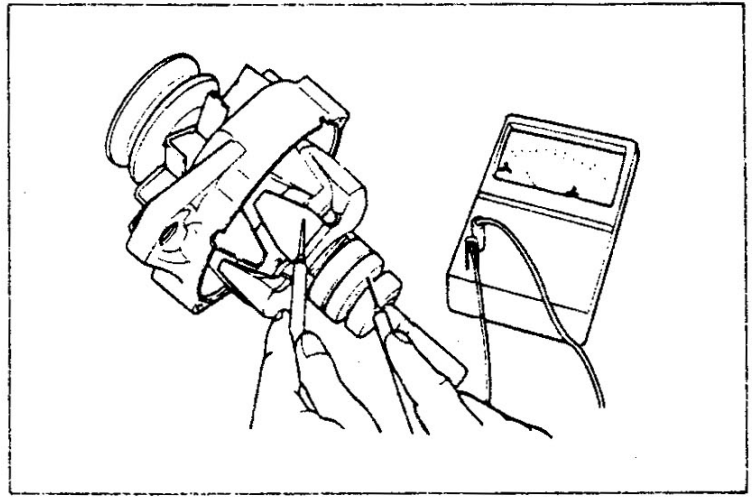

- 2) Measure the resistance between the slip rings. Replace the rotor if the resistance is not as specified.

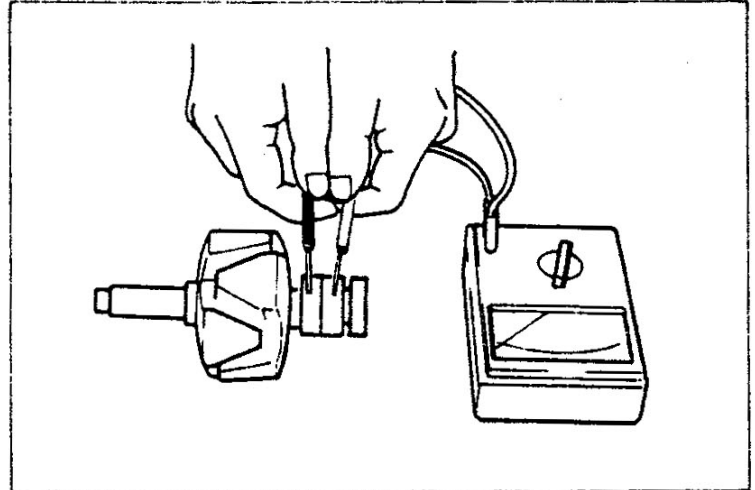

- 3) If the slip ring has rough surface or unevenly worn surface, correct with sandpaper or lathe.

Do not correct beyond the service limit of the slip ring O.D.

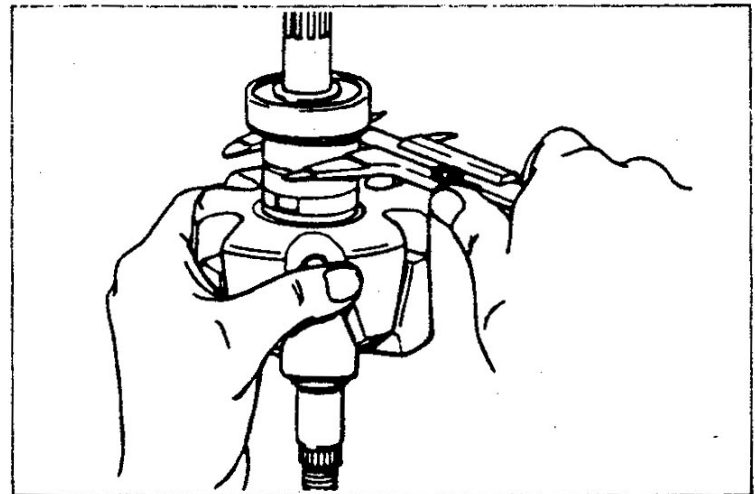

(c) Brush

- 1) Replace the brush if it is worn beyond the wear limit.

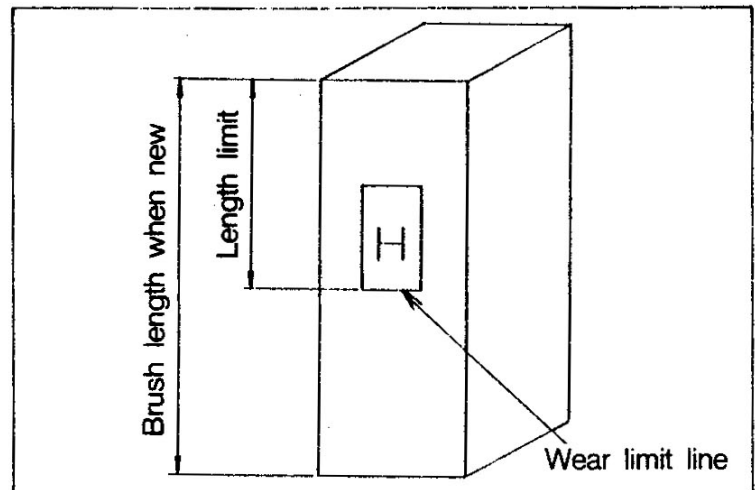

2) When a brush has been replaced, push in the new brush and measure the brush spring pressure.

If the spring pressure is lower than the service limit, replace the brush spring.

3) Replacement of brush and brush spring.

The brush and brush spring can be removed by unsoldering the pigtail.

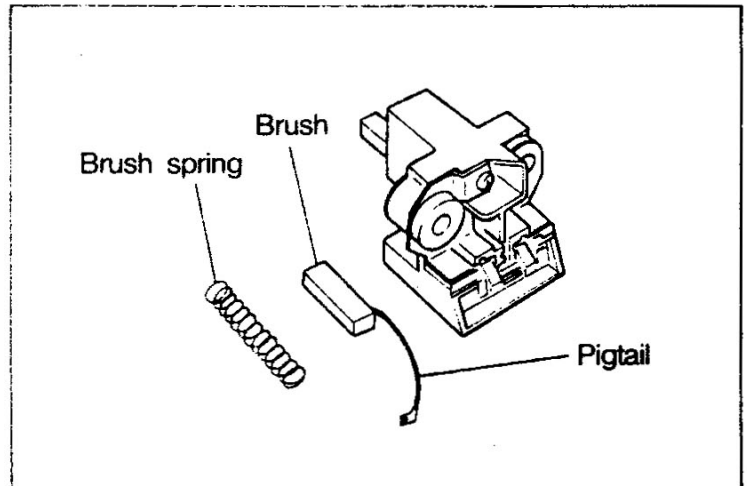

(d) Diode

For each diode, check the resistance between the diode leads and the heat sink.

Check the resistance in two manners, namely connecting the positive (+) tester lead to the diode or connecting the negative(-) lead to the diode.

The diode is open if the resistance is infinite in both cases.

The diode is shorted if the resistance is nearly 0 in both cases.

Replace the rectifier if the diode is open or shorted.

As for the diode trio, check resistance between diode trio leads.

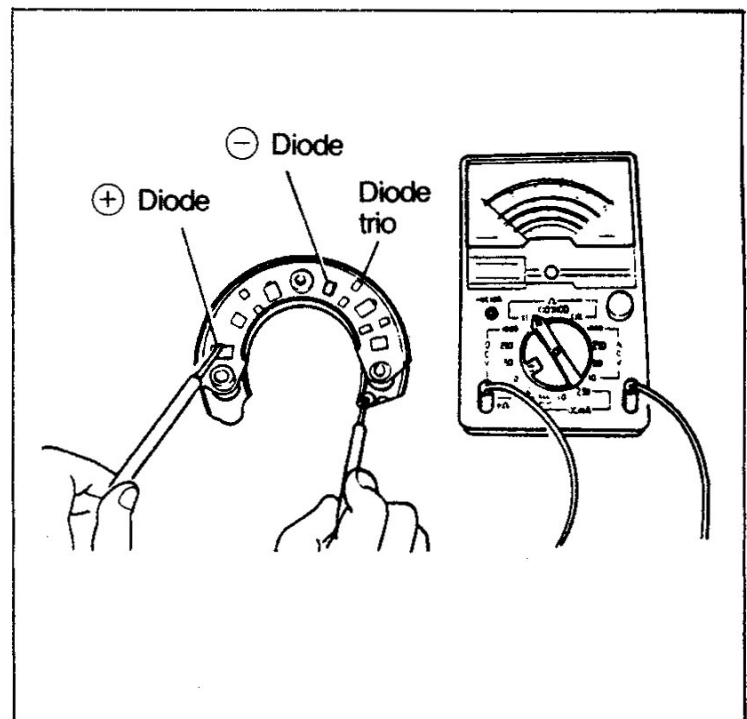

(3) Reassembly

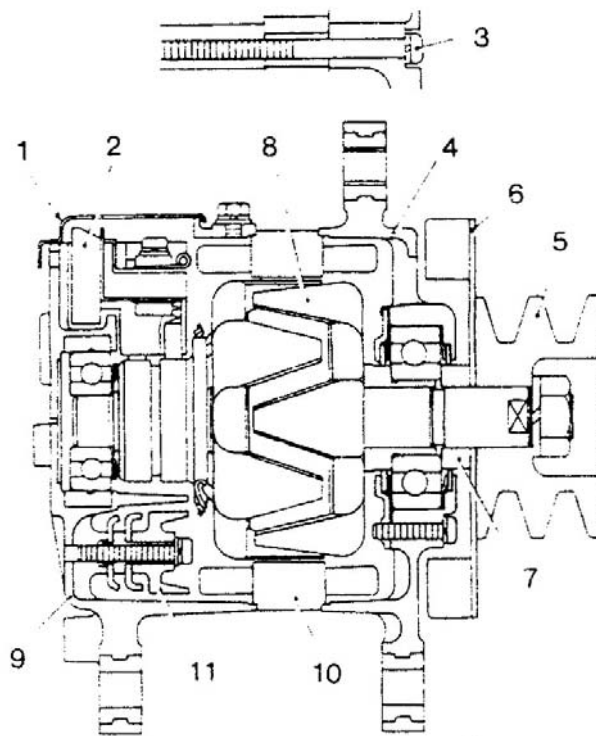

- NOTE : 1. When inserting the shaft through the oil seal, apply vinyl tape around the splined section of the shaft to prevent the oil seal lip from being damaged by the splined section.
2. When inserting the oil seal into the rear bracket, work uniformly on the outer circumference of the oil seal to prevent local shock or heavy shock.

(4) Test

(a) Performance test(on test bench)

Characteristics under load

	Model	40A	
Characteristics when loaded	Terminal voltage	27V	
	Current	When cold	26A or more
		When hot	22A or more
	Rotating speed	1500rpm	
	Terminal voltage	27V	
	Current	When cold	37A or more
		When hot	33A or more
	Rotating speed	2500rpm	

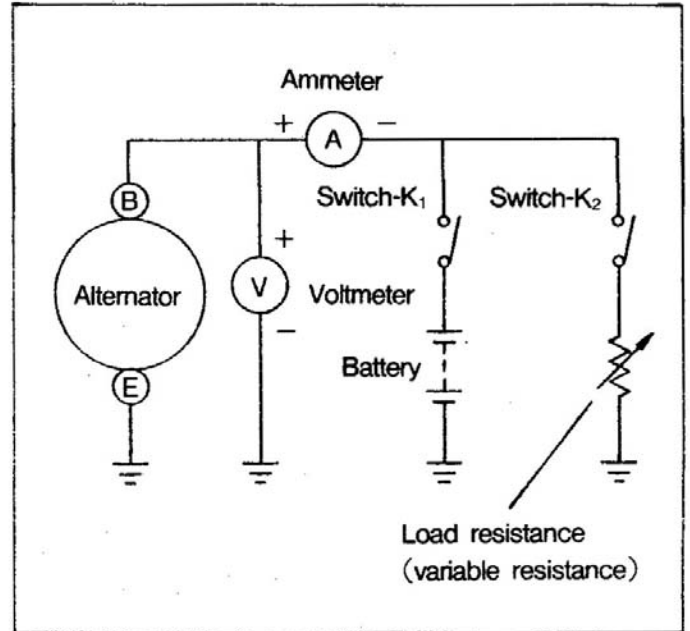

With the load resistance set at maximum(almost no load current flowing), close switches K₁ and K₂. While increasing the alternator speed gradually, decrease the load resistance and measure the specified terminal voltage and the current value at specified speed.

If the measurement reading is less than the specified level, check each section of the alternator.

(b) Performance test(as mounted to engine)

1) Provide a switch between the battery and the alternator "B" terminal. With the switch turned off, connect an ammeter(60A class) and a voltmeter.

2) Turn on the switch to check that the voltmeter indicates the battery voltage.

3) Start up the engine and immediately turn on all lamp switches. Then, increase the engine speed and read the maximum current value as soon as the alternator speed reaches 5000rpm.

4) If the current reading is 70% or more of the nominal output, the alternator may be safely regarded as good.

NOTE : The on-vehicle inspection is a simple way of inspection and the test bench inspection is necessary for more accurate results.

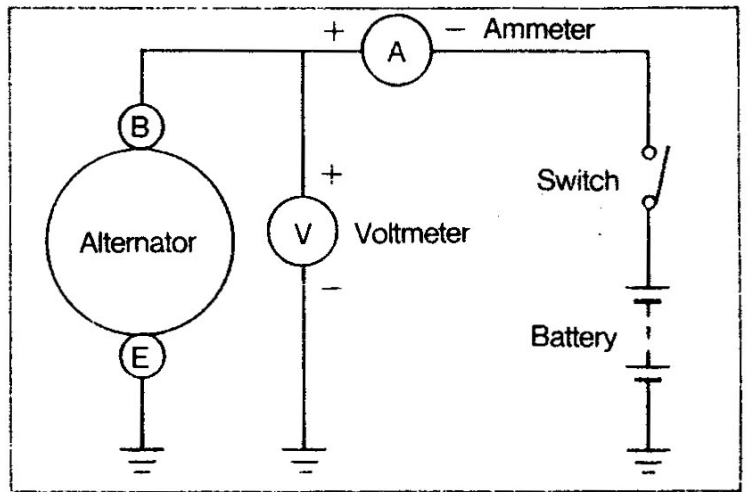

(c) IC regulator regulated voltage inspection(on test bench)

IC regulator regulated voltage

28 to 29V	Measured between terminals L and E at 5000rpm, load 5A or less
-----------	--

Use a fully charged battery. Close the switch and gradually increase the alternator speed to 5000rpm. Check that the current value at this speed is 5A or less. The regulator is good if the regulated voltage un-

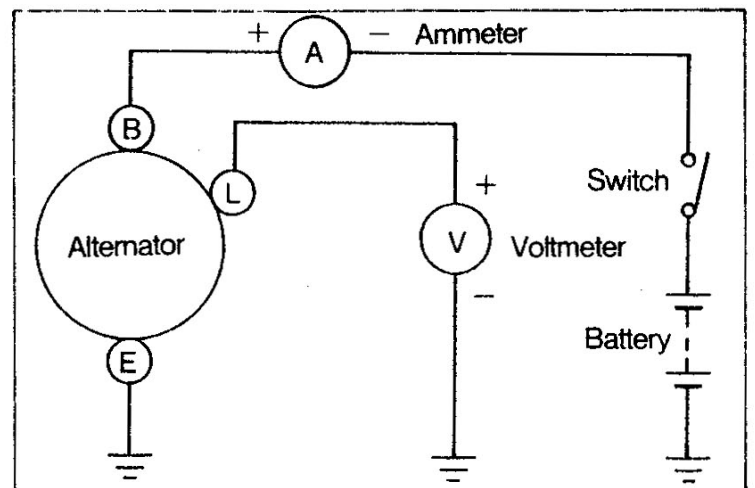

der this condition is as specified.

If not, replace the regulator assembly as the regulated voltage is not readjustable.

(d) IC regulator regulated voltage inspection(as mounted to engine)

- 1) Connect a voltmeter and an ammeter and provide a switch.
- 2) The regulator is normal if the voltmeter reads 0 when the switch is closed. If the voltmeter pointer deflects, the alternator or wiring is defective.
- 3) With the ammeter terminal shorted to prevent flow of the starter current through it, start up the engine.

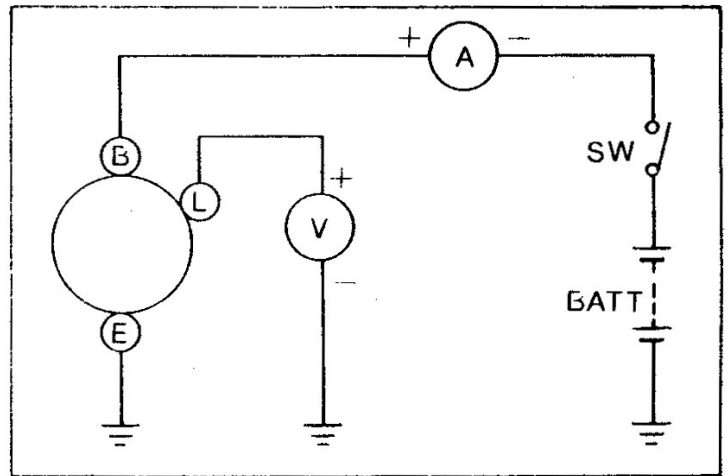

- 4) Increase the engine speed to approximately 2000rpm and read the regulator voltage value if the charge current is 5A or less.

If the charge current is 5A or more, continue charging for some time or replace with a fully charged battery. It is also acceptable to connect a 1/4 resistor(25W) in series to the battery to limit the charge current.

- 5) It is good if the regulator voltage is as specified.

If not, replace the regulator assembly as the regulator voltage is not readjustable.

12-4 AIR HEATER

Standard Limits

Indicator resistance	12.2Ω
Heater relay resistance	10.4Ω
Air heater resistance	0.23 to 0.27Ω
Time required for indicator to be red hot	40 to 60 sec.

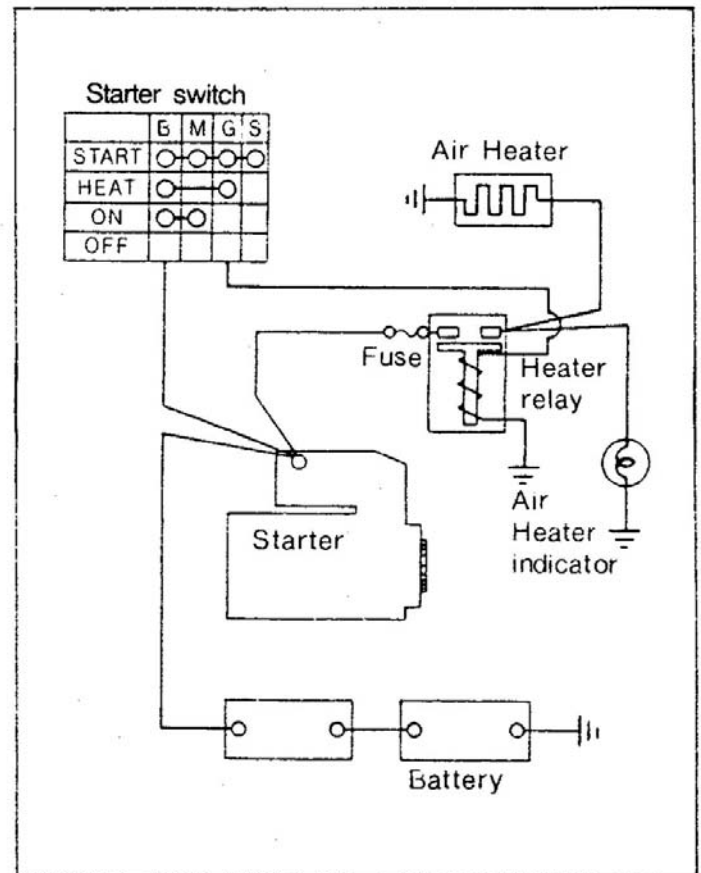

The heater relay is provided with a fuse of the air heater circuit. Check the fuse and replace if burned out, after determining the cause of the burn-out.

For replacement, be sure to use a fuse of the amperage(91A) marked on the burned out fuse.

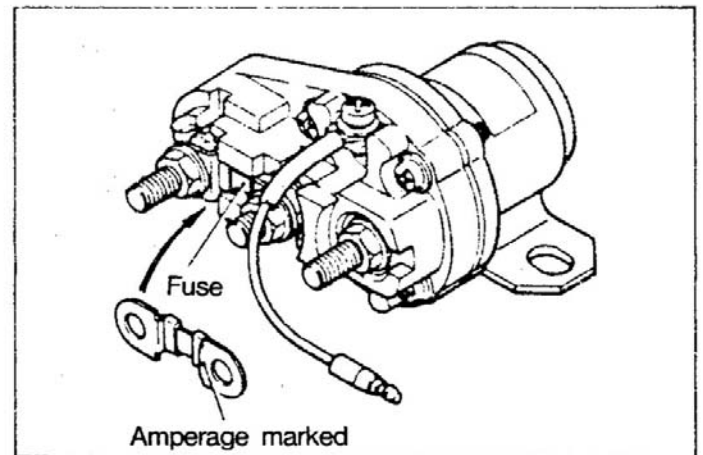

13-1 INJECTION PUMP DRIVE

13-1-1 Disassembly

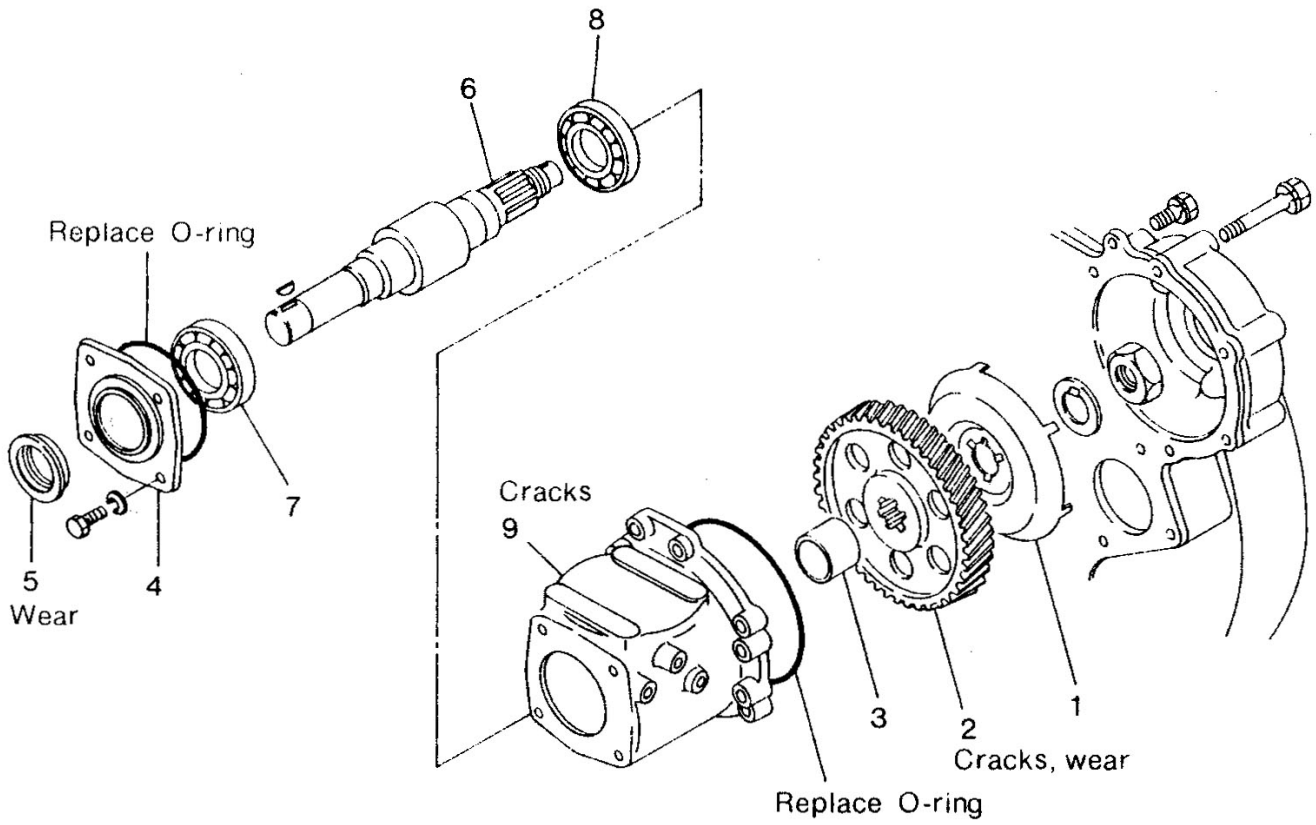

1 Sensor plate

2 Injection pump gear

3 Collar

4 Bearing holder

5 Oil seal

6 Shaft

7 Bearing

8 Bearing

9 Crankcase

(1) Remove the following parts.

- 1 Sensor plate
- 2 Injection pump gear
- 3 Collar

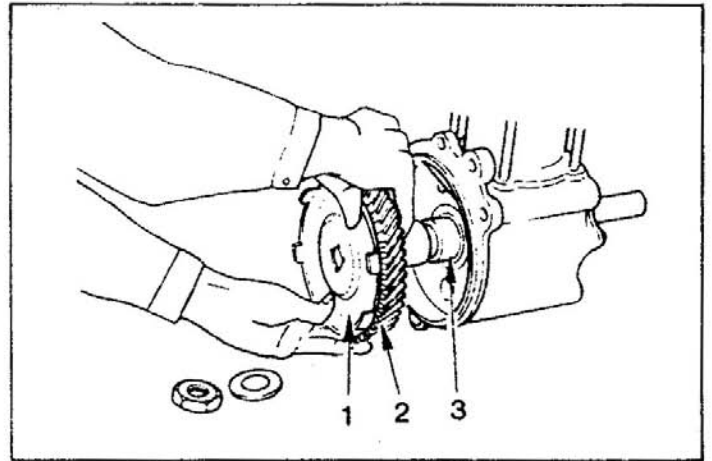

(2) Remove the bearing holder 4

TOTE : 1. When that bearing holder is removed, take care not to damage the oil seal 5.

- 2. Do not remove the oil seal from the bearing holder unless it is defective.

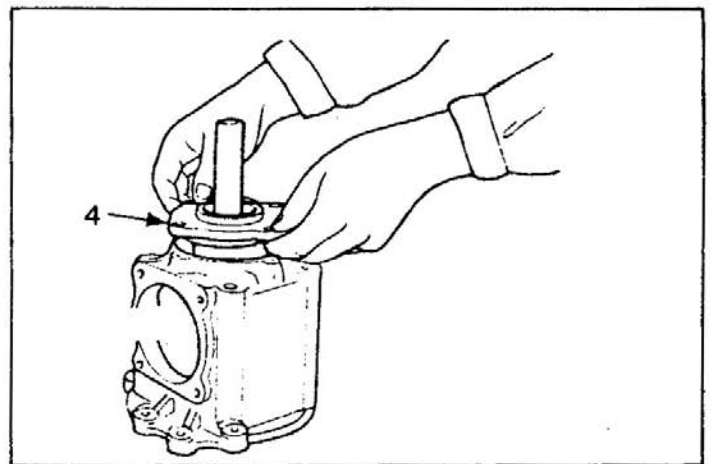

(3) Remove the shaft 6 from the crankcase 9.

NOTE : Do not remove the bearings 7 and 8 from the crankcase unless they are defective.

13-1-2 Inspection and Correction

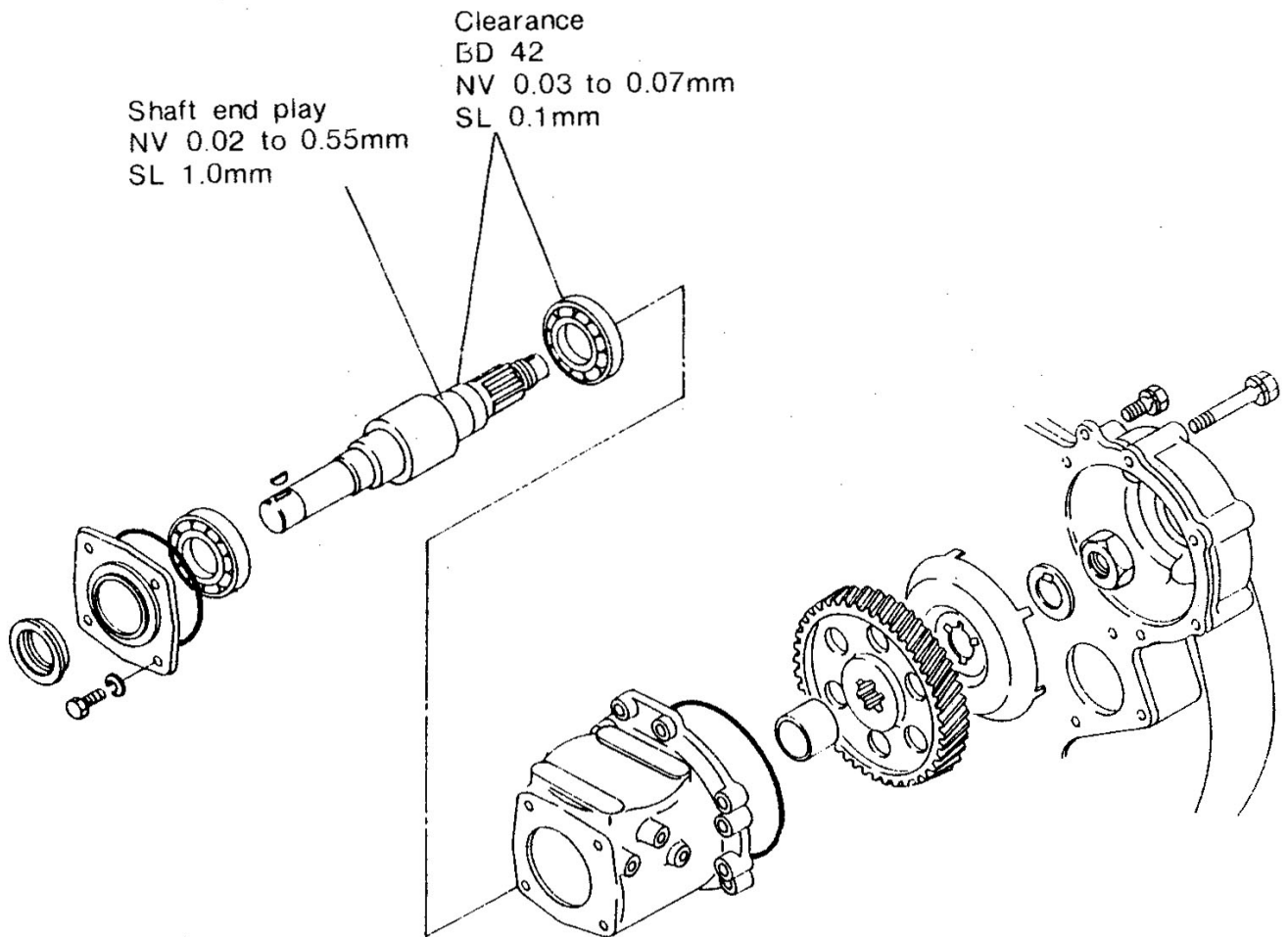

13-1-3 Reassembly

Install with "O" mark
aligned with "U" mark

NV... Nominal Valve
SL... Service Limit

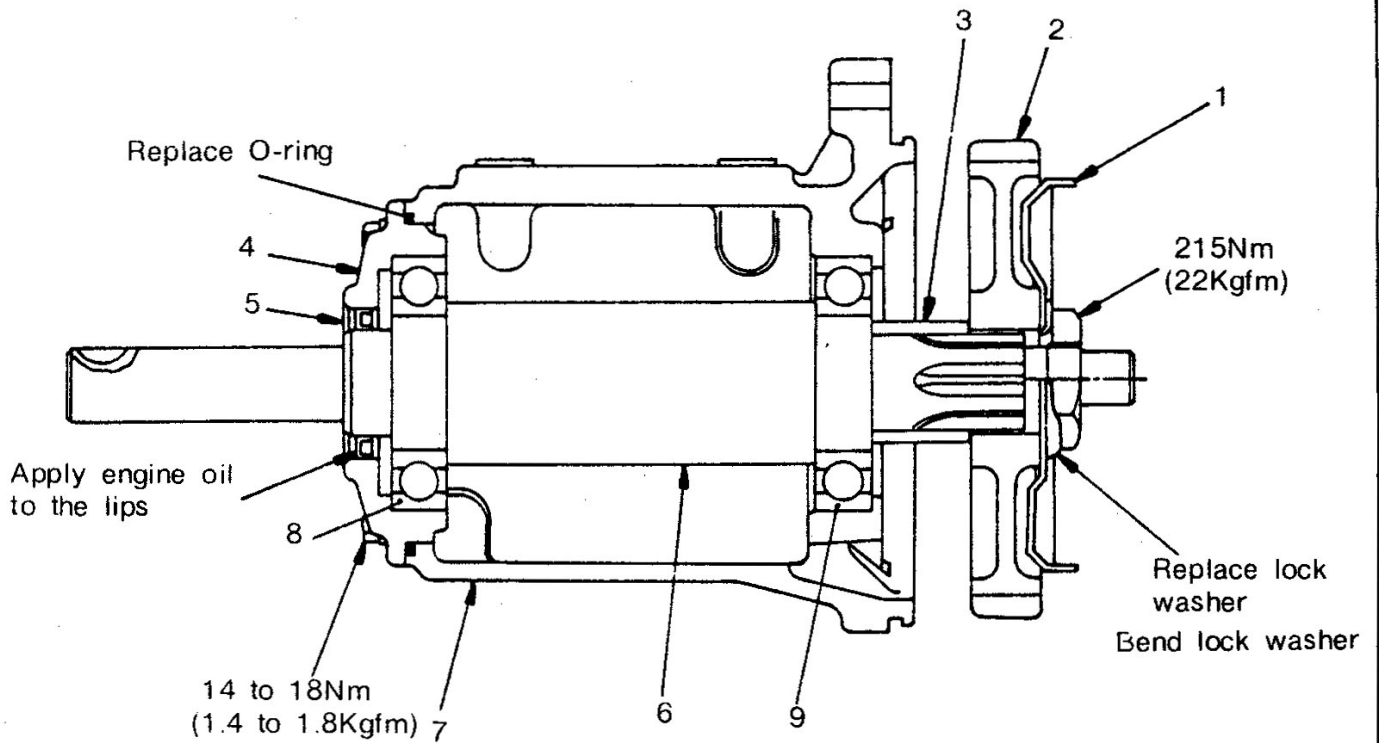
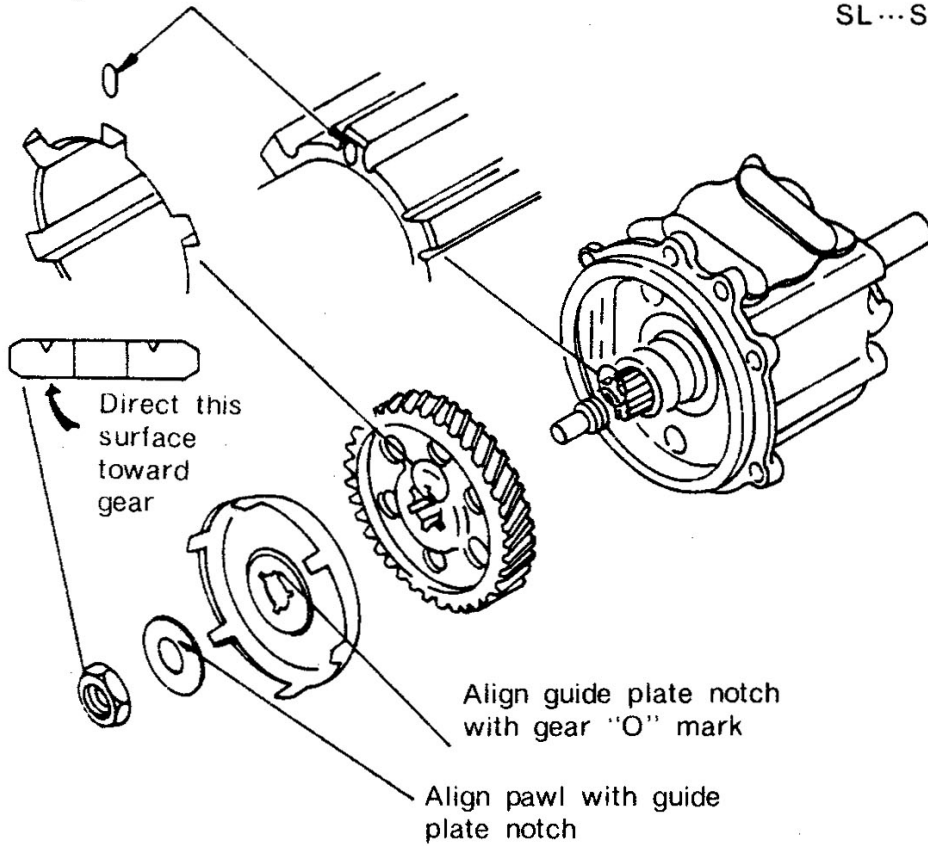

Assembling sequence

9 → 8 → 7 → 6 → 5 → 4 → 3 → 2 → 1

13-2 AUTOMATIC STOP SYSTEM

13-2-1 Inspection

(1) Stop Solenoid (Energize to RUN Type)

Energize the stop solenoid and check to see that the stop lever comes to the RUN position. Using an ammeter, check to see that when the solenoid is held, only the holding coil is energized.

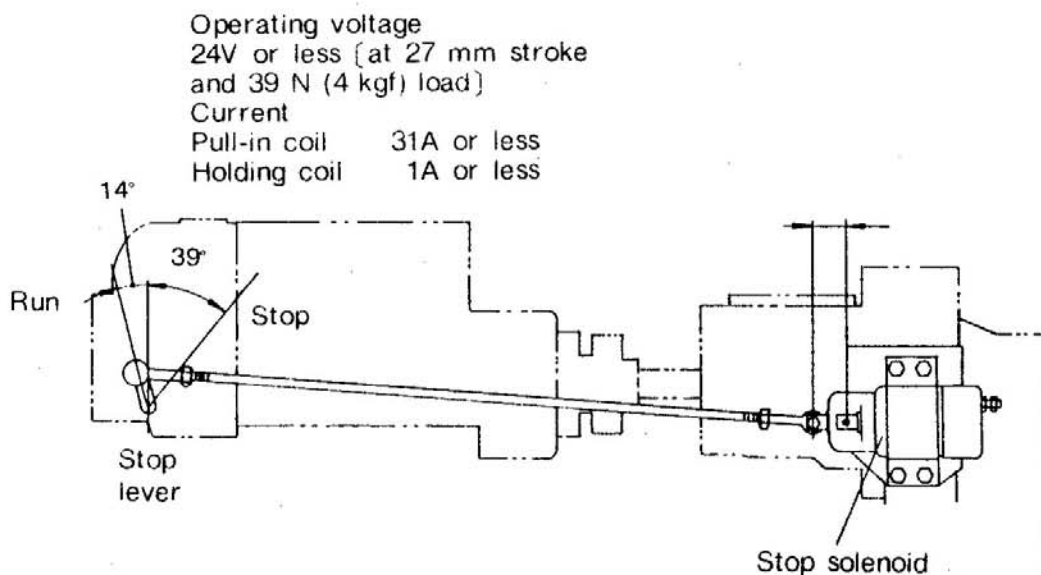

Before attraction

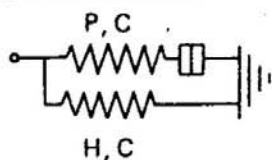

After attraction

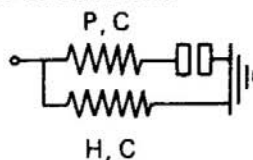

(2) Over heat warning unit

The over heat warning unit won't operate if the temperature-sensing portion is not in contact with coolant. If the coolant level is low or if there is only steam, the over heat warning unit won't operate completely.

Immerse the temperature-sensing portion in water, heat the water, and check the over heat warning unit operating temperature with a mercury THERMOMETER

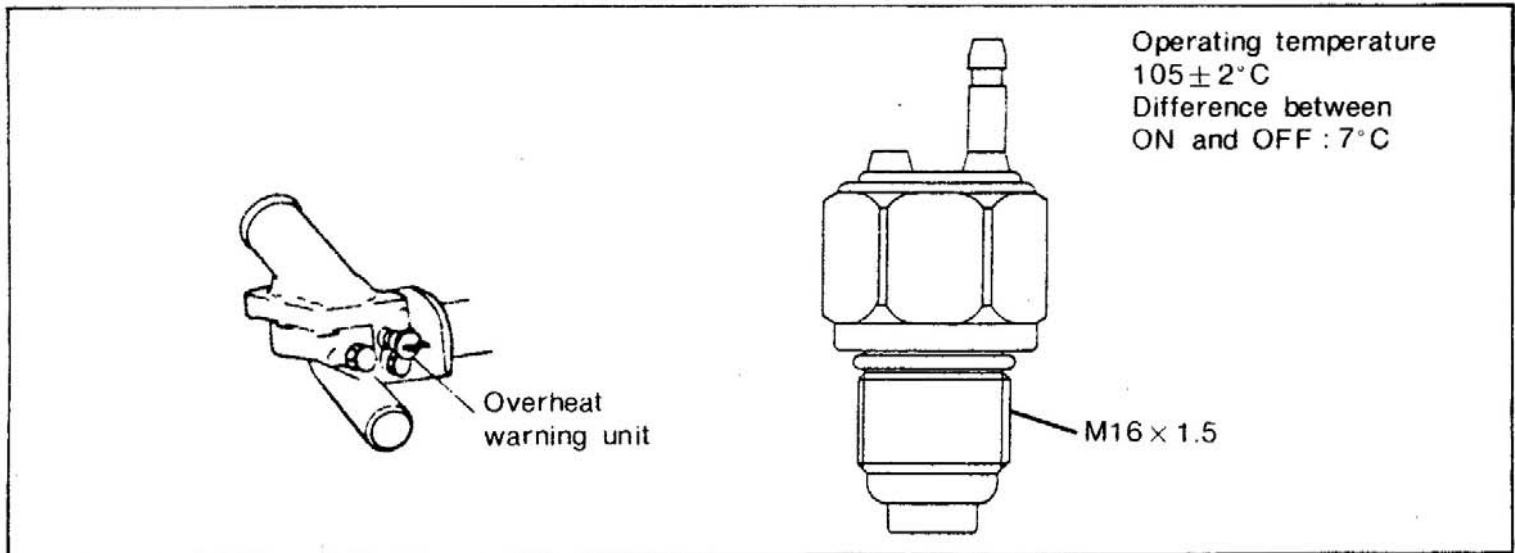

(3) Oil Pressure Switch

Connect the pipes as shown above, close the cocks A and B, and start the engine. After the oil pressure has risen, fully open the cock A to lead the oil pressure to the oil pressure switch. Then close the cock A to shut off the oil passage to the engine and hold the oil reservoir.

Slowly open the cock B to lower the oil pressure and check the oil pressure switch operating oil pressure with the test oil pressure gauge.

