

## 2. SPECIFICATIONS

### 1) WITHOUT TOOTH AND CUTTING EDGE TYPE BUCKET

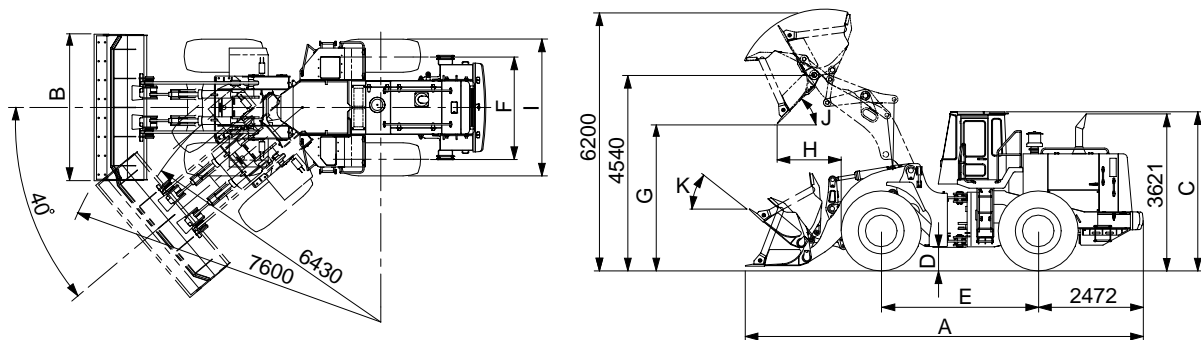

Description		Unit	Specification	
Operating weight		kg(lb)	28715(63306)	
Bucket capacity	Struck	m <sup>3</sup> (yd <sup>3</sup> )	4.0(5.2)	
	Heaped		4.7(6.2)	
Overall length	A	mm(ft-in)	9195(30' 2")	
Overall width	B		3450(11' 4")	
Overall height	C		3670(12' 0")	
Ground clearance	D		475(1' 7")	
Wheelbase	E		3700(12' 2")	
Tread	F		2440(8' 0")	
Dump clearance at 45.	G		3480(11' 5")	
Dump reach	H		1435(4' 8")	
Width over tires	I		3220(10' 7")	
Dump angle	J		Degree (°)	45
Roll back angle(Carry position)	K			48
Cycle time	Lift(With load)		sec	6.4
	Dump(With load)			1.6
	Lower(Empty)	3.6		
Maximum travel speed		km/hr(mph)	37.4(23.3)	
Braking distance		m(ft-in)	12(39' 4")	
Minimum turning radius(Center of outside tire)			6.43(21' 1")	
Gradability		Degree (°)	30	
Travel speed	Forward	First gear	7.6(4.7)	
		Second gear	13.3(8.3)	
		Third gear	22.3(13.9)	
		Fourth gear	37.4(23.3)	
	Reverse	First gear	7.6(4.7)	
		Second gear	13.3(8.3)	
		Third gear	22.3(13.9)	
		Fourth gear	37.4(23.3)	

## 2) BOLT-ON CUTTING EDGE TYPE BUCKET

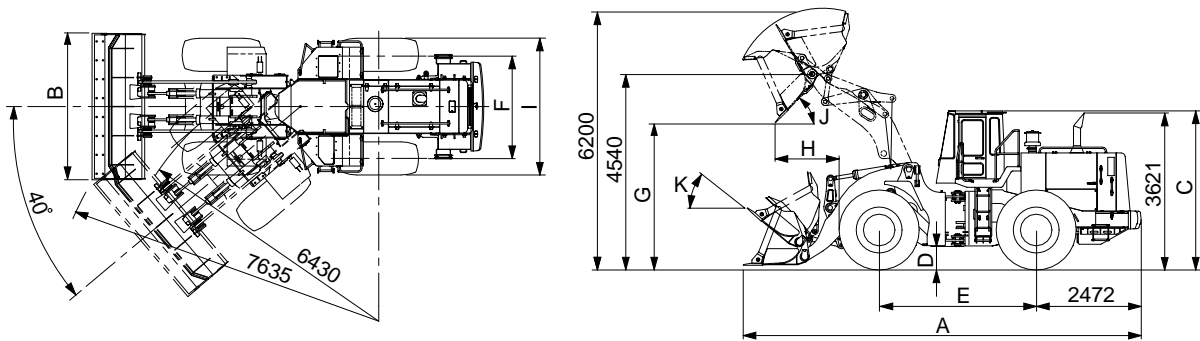

Description		Unit	Specification	
Operating weight		kg(lb)	29000(63934)	
Bucket capacity	Struck	m <sup>3</sup> (yd <sup>3</sup> )	4.2(5.5)	
	Heaped		5.0(6.5)	
Overall length	A	mm(ft-in)	9310(30' 7")	
Overall width	B		3450(11' 4")	
Overall height	C		3670(12' 0")	
Ground clearance	D		475(1' 7")	
Wheelbase	E		3700(12' 2")	
Tread	F		2440(8' 0")	
Dump clearance at 45°	G		3395(11' 2")	
Dump reach	H		1470(4' 10")	
Width over tires	I		3220(10' 7")	
Dump angle	J		Degree (°)	45
Roll back angle(Carry position)	K			48
Cycle time	Lift(With load)		sec	6.4
	Dump(With load)	1.6		
	Lower(Empty)	3.6		
Maximum travel speed		km/hr(mph)	37.4(23.3)	
Braking distance		m(ft-in)	12(39' 4")	
Minimum turning radius(Center of outside tire)			6.43(21' 1")	
Gradability		Degree (°)	30	
Travel speed	Forward	First gear	7.6(4.7)	
		Second gear	13.3(8.3)	
		Third gear	22.3(13.9)	
		Fourth gear	37.4(23.3)	
	Reverse	First gear	7.6(4.7)	
		Second gear	13.3(8.3)	
		Third gear	22.3(13.9)	
		Fourth gear	37.4(23.3)	

### 3) WITH TOOTH TYPE BUCKET

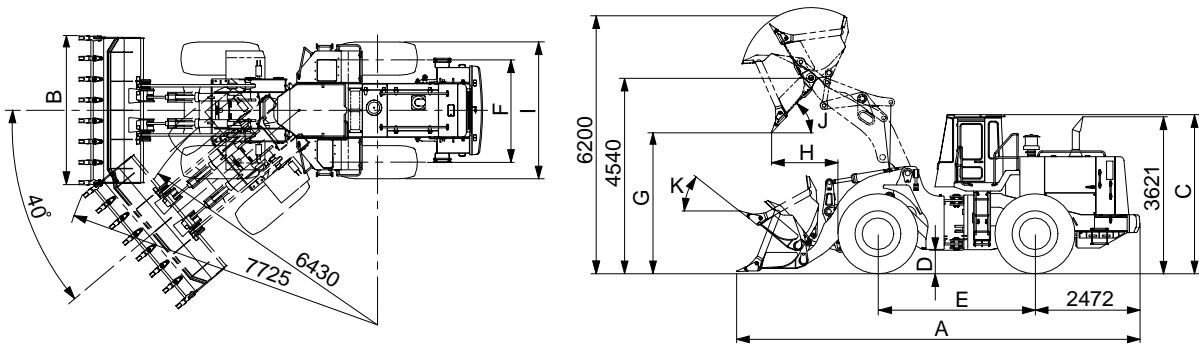

Description		Unit	Specification	
Operating weight		kg(lb)	28905(63725)	
Bucket capacity	Struck	m <sup>3</sup> (yd <sup>3</sup> )	4.0(5.2)	
	Heaped		4.7(6.2)	
Overall length	A	mm(ft-in)	9470(31' 1")	
Overall width	B		3500(11' 6")	
Overall height	C		3670(12' 0")	
Ground clearance	D		475( 1' 7")	
Wheelbase	E		3700(12' 2")	
Tread	F		2440( 8' 0")	
Dump clearance at 45.	G		3240(10' 8")	
Dump reach	H		1590( 5' 3")	
Width over tires	I		3220(10' 7")	
Dump angle	J		Degree (.)	45
Roll back angle(Carry position)	K			48
Cycle time	Lift(With load)	sec	6.4	
	Dump(With load)		1.6	
	Lower(Empty)		3.6	
Maximum travel speed		km/hr(mph)	37.4(23.3)	
Braking distance		m(ft-in)	12(39' 4")	
Minimum turning radius(Center of outside tire)			6.43(21' 1")	
Gradability		Degree (.)	30	
Travel speed	Forward	First gear	7.6(4.7)	
		Second gear	13.3(8.3)	
		Third gear	22.3(13.9)	
		Fourth gear	37.4(23.3)	
	Reverse	First gear	7.6(4.7)	
		Second gear	13.3(8.3)	
		Third gear	22.3(13.9)	
		Fourth gear	37.4(23.3)	