

### 3. STARTING AND STOPPING THE ENGINE

#### 1) CHECK INDICATOR LIGHTS

- (1) Check if parking brake switch is ON.
  - (2) Check if gear selector lever is in neutral position.
  - (3) Check if hydraulic safety lever is in the lock position.
  - (4) Turn the key to the ON position, and check following.
    - ① If all the lamps light ON after sounding buzzer for 3 seconds.
      - ※ **If the lamps do not light or the buzzer is not sounded, check disconnection of wire.**
    - ② Only below lamps will light ON and all the other light will be turn OFF after 3 seconds.
      - Charging warning lamp(1)
      - Engine oil pressure warning lamp(2)
      - Brake fail warning lamp(3)
- ※ **Refer to the START PROCEDURE on the page 0-11.**

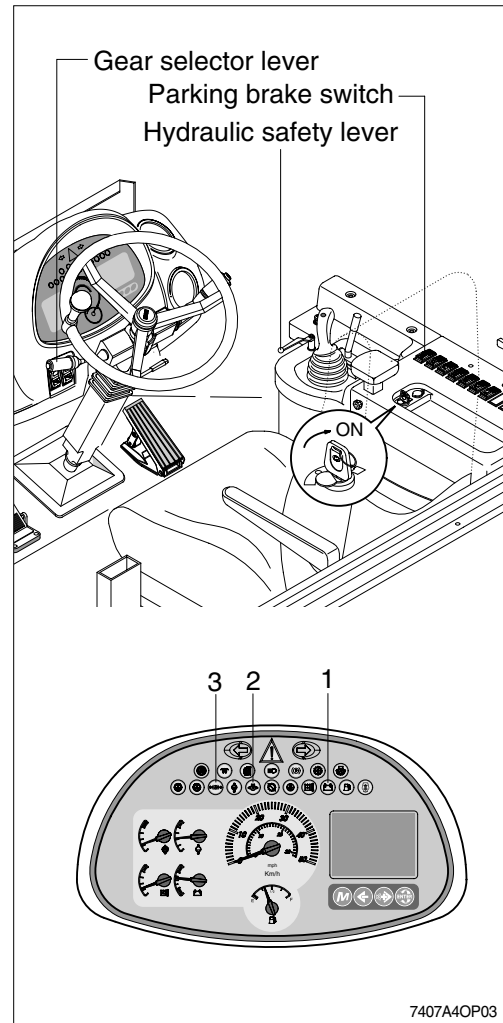

#### 2) STARTING ENGINE IN NORMAL TEMPERATURE

- ※ **Sound the horn to warn the surroundings after checking if personnel or obstacles are in the area.**
- (1) Turn the starting switch to START position to start the engine.
    - ※ **If the engine does not start, allow the starter to cool for about 2 minutes before attempting to start the engine again.**
  - (2) Release the starting switch instantly after the engine starts to avoid possible damage to the starting motor.

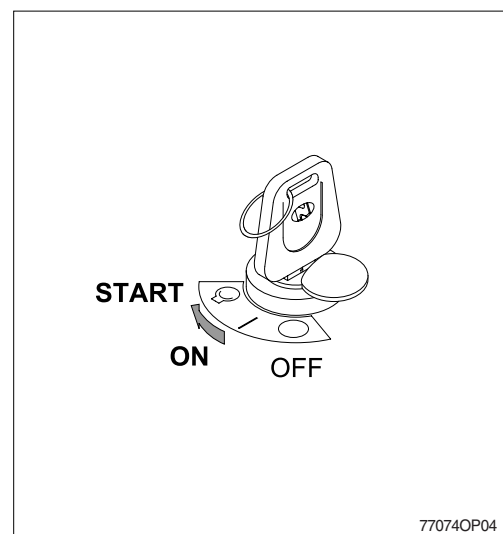

### 3) STARTING ENGINE IN A COLD WEATHER

- ※ Sound horn to warn surroundings after checking if there are obstacles in the area.
- ※ Replace the engine oil and fuel referring to recommended oils at page 6-9.
- ※ Fill the anti-freeze solution to the coolant as required.
- ※ If you turn ON the starting switch, the fuel warmer is automatically operated to heat the fuel by sensing the coolant temperature.

- (1) Check if the parking brake is locked(With the parking switch ON).
- (2) Check if the gear selector lever is in the neutral position.
- (3) Check if the hydraulic safety lock lever is in the lock position.
- (4) Turn the starting switch to ON position, and wait 1~2 minutes. More time may take according to ambient temperature and wait the preheater pilot lamp OFF.

- (5) Start the engine by turning the starting switch to START position after the preheater pilot lamp OFF.

- ※ If the engine does not start, allow the starter to cool for about 2 minutes before attempting to start the engine again.

- (6) Release starting switch immediately after starting engine. The starting switch will automatically return to the ON position.

- ※ After engine started, the preheating function is actuated to reduce the white smoke.

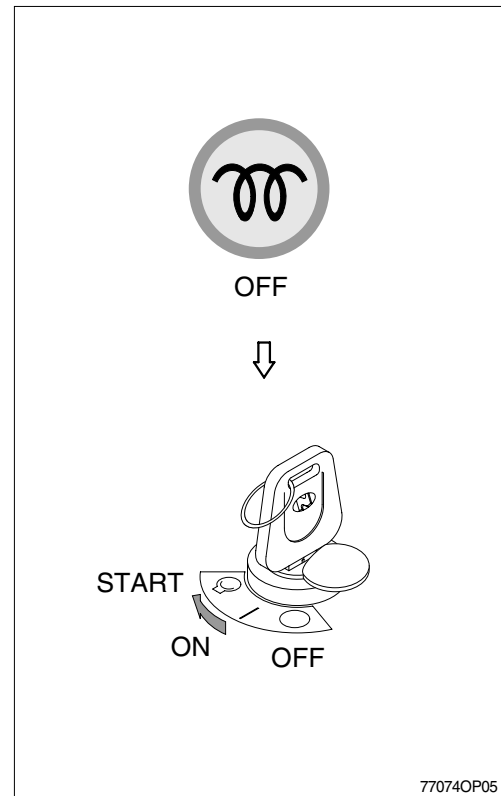

### 4) INSPECTION AFTER ENGINE START

Inspect and confirm the following after engine starts.

- (1) Is the level gauge of hydraulic oil tank in the normal level?
- (2) Are there leakages of oil or water?
- (3) Are all the warning lamps(1-11) OFF?
- (4) Check the following after warming up operation.
  - ① Is the indicator of water temperature gauge (12) in the operating range?
  - ② Is the indicator of transmission oil temperature gauge(13) in the operating range?
  - ③ Is the engine sound and the color of exhaust gas normal?
  - ④ Are the sound and vibration normal?

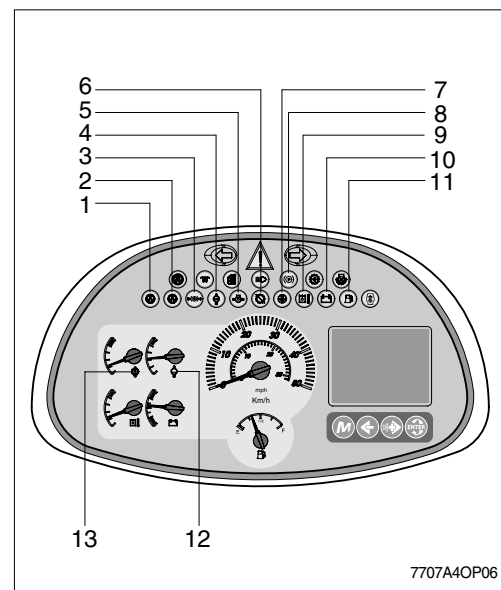

- ※ Do not increase engine speed quickly after starting, it can make damage engine or turbocharger.

- ※ If there are problems in the control panel, stop the engine immediately and correct problem as required.

## 5) TRANSMISSION COLD STARTING

- (1) At an oil temperature in the shifting circuit  $< -12^{\circ}\text{C}$ , the transmission must be warmed-up for some minutes.
- (2) This must be carried out in neutral with an increased engine speed.
- (3) Until this oil temperature is reached, the electronics remains in neutral, and the symbol of the cold start phase will be indicated on the display.
  - Indication on the display :
- (4) After the indication on the display is extinguished, the full driving programm can be utilized out of NEUTRAL.



## 6) TO STOP THE ENGINE

- ※ If the engine is abruptly stopped before it has cooled down, engine life may be greatly shortened. Consequently, do not abruptly stop the engine apart from an emergency.
  - ※ In particularly if the engine has overheated, do not abruptly stop it but run it at medium speed to allow it to cool gradually, then stop it.
- (1) Place the gear selector lever in neutral.
  - (2) Turn the parking brake switch ON.
  - (3) Run the engine for five minutes at low idle with no load.
  - (4) Return the key of starting switch to the OFF position.
  - (5) Remove the key to prevent other people using the machine and LOCK safety lever.
  - (6) Lock the cab door.

