

HYUNDAI EQUIPMENT LIABILITY WARRANTY

THE WARRANTY IS THE ONLY OBLIGATION OF HYUNDAI OR A HYUNDAI DEALER TO THE PURCHASER OR ANYONE ELSE CONCERNING A PRODUCT, ITS SERVICE, ITS USE OR PERFORMANCE OR ITS LOSS OF USE OR FAILURE TO PERFORM. NEITHER HYUNDAI NOR A HYUNDAI DEALER HAVE MADE AND NEITHER WILL MAKE ANY OTHER EXPRESSED OR IMPLIED REPRESENTATION, WARRANTY OR AGREEMENT CONCERNING A PRODUCT. NEITHER HYUNDAI NOR A HYUNDAI DEALER HAVE MADE OR WILL MAKE ANY REPRESENTATION, WARRANTY OR AGREEMENT CONCERNING A PRODUCTS MERCHANTABILITY OR OTHER QUALITY, ITS SUITABILITY FOR PURCHASER'S PURPOSE (EVEN IF A PURCHASER HAS INFORMED HYUNDAI OR A HYUNDAI DEALER OF THAT PURPOSE), ITS DURABILITY, PERFORMANCE OR OTHER CONDITION.

EVEN IF HYUNDAI OR A HYUNDAI DEALER WAS ADVISED OF THE POSSIBILITY OF SUCH LOSS, NEITHER HYUNDAI NOR A HYUNDAI DEALER WILL BE LIABLE TO PURCHASER OR ANYONE ELSE FOR ANY INDIRECT, INCIDENTAL CONSEQUENTIAL, PUNITIVE, ECONOMIC, COMMERCIAL, OR SPECIAL LOSS WHICH IS IN ANY WAY ASSOCIATED WITH A PRODUCT. THIS INCLUDES ANY LOSS OF USE OR NON-PERFORMANCE OF A PRODUCT, ANY REPLACEMENT RENTAL OR ACQUISITION COST, ANY LOSS OF REVENUE OR PROFITS, ANY FAILURE TO REALIZE EXPECTED SAVINGS, ANY INTEREST COSTS, ANY IMPAIRMENT OF OTHER GOODS, ANY INCONVENIENCE OR ANY LIABILITY OF PURCHASER TO ANY OTHER PERSON.

PURCHASER MAY NOT ATTEMPT TO ENLARGE ITS RIGHTS UNDER THE WARRANTY BY MAKING A CLAIM FOR INDEMNITY, FOR BREACH OF CONTRACT, FOR BREACH OF COLLATERAL WARRANTY, FOR A TORT (INCLUDING NEGLIGENCE, MISREPRESENTATION OR STRICT LIABILITY) OR BY CLAIMING ANY OTHER CAUSE OF ACTION.

THE WARRANTY IS A CONDITION OF SALE OF THE PRODUCT TO PURCHASER AND WILL THEREFORE APPLY EVEN IF PURCHASER ALLEGES THAT THERE IS A TOTAL FAILURE OF THE PRODUCT.

*N.B. Read and practice your **Hyundai** operating and servicing instructions. Failure to do this may void your warranty.*

INDEX

1. SAFETY PRECAUTIONS

2. CONTROLS

- 2. 1 Instrument Panel
- 2. 2 Seat and Seat Belt
- 2. 3 Seat Bar
- 2. 4 Parking Brake
- 2. 5 Throttle Control
- 2. 6 Lift Arm Supports
- 2. 7 Steering Controls
- 2. 8 Hand Controls
- 2. 9 Electrical Solenoid Auxiliary
- 2. 10 Foot Pedals
- 2. 11 Quick-Tach
- 2. 12 Electrical Panel

3. OPERATION

- 3. 1 Starting Instructions
- 3. 2 Operating Procedure
- 3. 3 Filling From a Pile
- 3. 4 Digging with a Bucket
- 3. 5 Leveling and Backfilling
- 3. 6 Auxiliary Hydraulics
- 3. 7 Lifting
- 3. 8 Towing
- 3. 9 Securing and Transporting
- 3. 10 Battery Maintenance and Boosting
- 3. 11 Lower Lift Arms

4. MAINTENANCE

- 4. 1 Preventative Maintenance Service Schedule
- 4. 2 Daily Service Checks
- 4. 3 50 Hour Service Check
- 4. 4 Service Access
- 4. 5 Final Drive Maintenance
- 4. 6 Hydraulic / Hydrostatic System Maintenance
- 4. 7 Engine Maintenance
- 4. 8 Air Cleaner Maintenance
- 4. 9 Electrical System
- 4. 10 Tire Maintenance
- 4. 11 Trouble Shooting
- 4. 12 Hydraulic / Hydrostatic Circuit
- 4. 13 Special Tools

5. SPECIFICATIONS

- 5. 1 Loader Specifications
- 5. 2 Torque Specifications
- 5. 3 Sound Power Level
- 5. 4 Decals, Warning

6. ATTACHMENTS AND BUCKETS

- 6. 1 Hyundai Approved Buckets and Attachments

FOREWORD

This book has been written to give the Owner / Operator necessary operating servicing and preventative maintenance instructions on the loader.
Read this manual completely and know the loader before operating or servicing it.
Do not do any service procedures that are not in the Operator's manual.
Only service personnel that have had training in the service of this loader can do these service procedures.

Reference Information

Write the correct information for your loaders in the spaces below. Always use these numbers when referring to your loader.

Model No. _____
Serial No. _____
Dealer Name _____
Address _____
Phone _____

Throughout this manual the terms DANGER, WARNING and CAUTION are used to indicate the degree of hazard in terms of personal safety. These words will be used in conjunction with the Safety - Alert symbol, a triangle with an exclamation mark.

Throughout this manual, the term IMPORTANT is used

- * To indicate that instructions are necessary before operating or servicing the loader.
- * To show important procedures which must be followed to prevent damage to the loader or attachment.

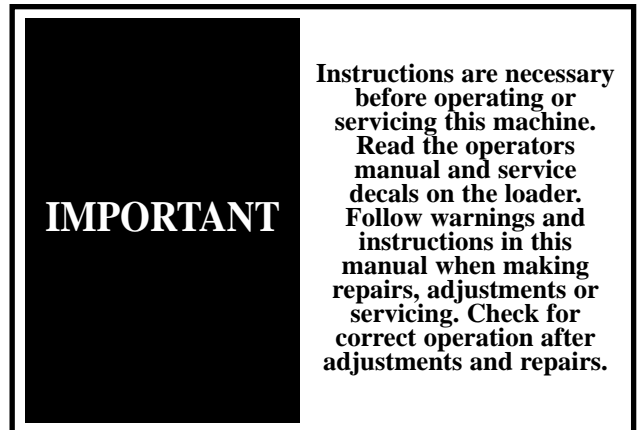
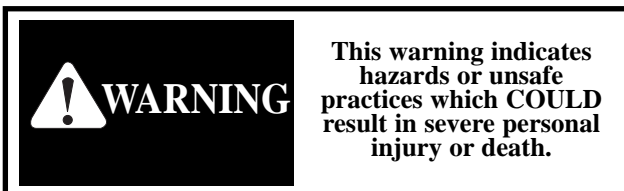

1...SAFETY PRECAUTIONS

The following precautions are suggested to help prevent accidents.

A careful operator is the best operator. Most accidents can be avoided by observing certain precautions. Read and take the following precautions before operating this loader to help prevent accidents. Equipment should be operated only by those who are responsible and instructed to do so.

1. Read this manual carefully before using the loader. Working with unfamiliar equipment can lead to accidents.
2. Do not allow anyone to ride on the loader with the operator.
3. Make sure the control locks and the seat bar are installed and functioning at all times.
4. Never run the engine in a closed building without adequate ventilation, as the exhaust fumes can cause death.
5. Always fasten the seat belt around your waist before starting the engine. Never fasten the seat belt behind you.
6. Never attempt to start the engine while standing beside the unit unless as specified in this manual or under specific service and backhoe operation procedures. Start the engine only while sitting in the operator's seat with the seat belt fastened around you. Always check to make certain that the seat cushion is secured to the frame.
7. Keep the operator's area free of debris.
8. Never enter or leave the loader while the engine is running. Always lower the lift arms down against the frame, drop the attachment down to contact the ground, set the parking brake and shut off the engine prior to leaving the loader.
9. If the unit is equipped with a cab enclosure kit always close the door prior to operating the loader lift arms.
10. Do not operate the loader unless all safety equipment, shields, seat belt, seat bar, hydraulic controls, parking brake, operator guard, and lift arm supports are working properly, as well as all safety and instruction decals are in place.
7. Always be sure of water, gas, sewage and electrical line locations before you start to dig.
8. Watch out for overhead and underground high-voltage electrical lines when operating the loader.
9. Always park the loader on level ground where possible. If the loader is to be parked on an incline, always lower the attachment so it contacts the ground, set the parking brake and block the wheels.
10. Do not leave the loader when it is in motion.
11. Do not dismount from the loader and leave the loader lift arms raised, unless following specific service procedures. Always lower the lift arms down against the frame and drop the attachment down to contact the ground.
12. Always be watchful of bystanders when operating the loader.
13. Always carry the attachment low for maximum stability and visibility.
14. Exercise extreme caution when operating the loader with a raised attachment.
15. Never attempt to lift loads in excess of loader capacity.
16. Check that the foot pedals are locked before getting out of the operator's seat.

MAINTENANCE

OPERATING THE LOADER

1. Always drive the loader at speeds compatible with safety, especially when operating over rough ground, crossing ditches or when turning.
2. Avoid jerky turns, starts, stops, or reverses.
3. Use care when operating on steep grades to maintain proper stability.
4. Do not turn the loader while the lift arms are in the raised position.
5. Be careful when driving through door openings or under overhead objects. Always make sure there is sufficient clearance for the operator's guard.
6. When travelling on public roads, know the local rules and regulations and make sure your loader is equipped with the proper safety equipment.
1. Stop the engine before performing any service on the loader.
2. Never refuel the loader while smoking or with the engine hot or running.
3. Replace all missing, illegible or damaged safety and warning decals. See section 5.4 for list.
4. Do not modify or alter, or permit anyone to modify or alter this loader or any of its components or any loader function.
5. Do not bypass the safety system. Consult your **Hyundai** Equipment Dealer if your safety controls are malfunctioning. Use jumper cables only in recommended manner. See section 3.10
6. Do not make mechanical adjustments while the loader is in motion or when the engine is running. However, if minor engine adjustments must be made, securely block the loader with the wheels clear of the ground, and use extreme caution.
7. Do not attempt to repair or tighten hydraulic hoses when the system is under pressure, when the engine is running or when the lift arms are raised.
8. Do not get under the attachment or lift arms or reach through the lift arms when they are raised.
9. Never attach the chains or ropes to the operator's guard for pulling purposes, as the loader can tip over.

1...SAFETY PRECAUTIONS

10. Whenever servicing or replacing pins in cylinder ends, buckets, etc., always use a brass drift and a hammer. Failure to do so could result in injury from flying metal fragments.
11. Cooling system operates under pressure which is controlled by the radiator cap. It is dangerous to remove the cap while system is hot. Always turn cap slowly to the first stop and allow the pressure to escape before removing the cap entirely.
12. Keep the operator and foot pedal areas free from debris.
13. For lifting and towing instructions, refer to sections 3. 7 and 3. 8 of this manual.

**WARNING**

To avoid personal injury, lower the lift arms, shut off the engine, raise the seat bar and cycle the hydraulics to ensure they are locked. Then, unlatch the seat belt and exit the loader. Do not enter or exit with the engine running unless as specified in this manual or under specific service and backhoe operating procedures.

**WARNING**

To prevent personal injury do not start the engine unless you are in the seat with the seat belt fastened around you.

PARK SAFELY

Select level ground whenever possible. If you must park on a slope or incline, position the machine at right angles to the slope. Lower the attachment to the ground, engage the parking brake and block the wheels (C359).

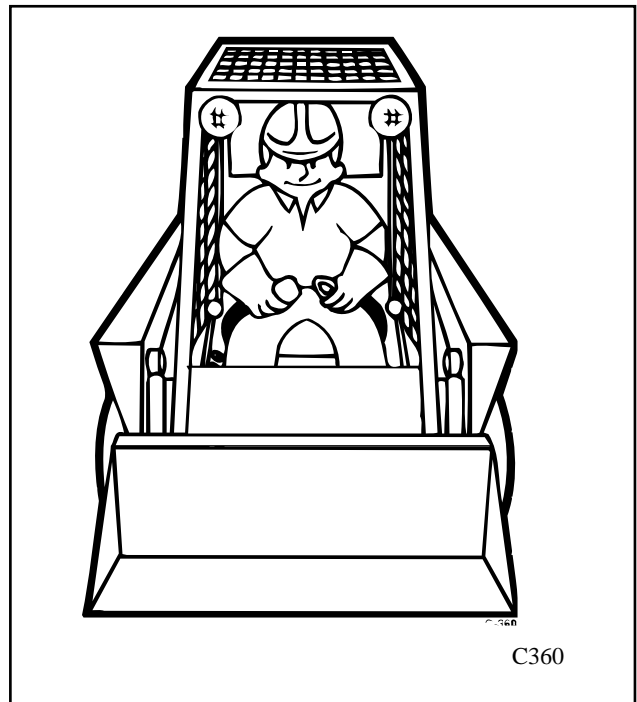
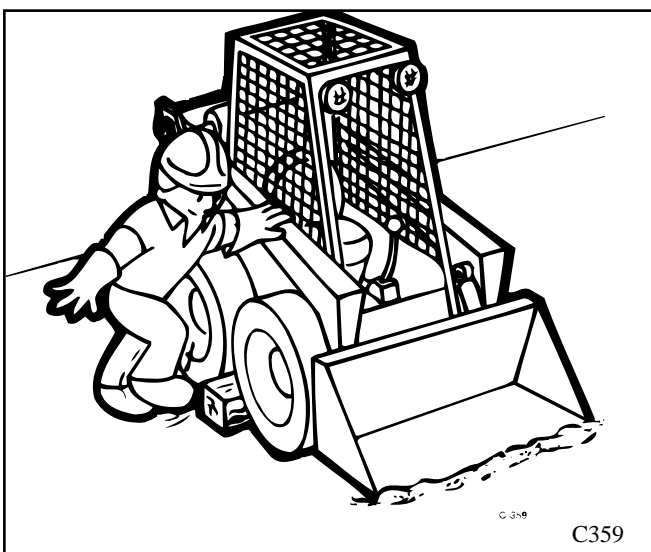

START SAFELY

1. Sit in the operator's seat and adjust it so you can operate all of the controls properly.
2. Adjust the seat and fasten the seat belt. Cycle the controls to make sure they are in the locked or neutral position. Lower the seat bar.
3. Know the exact starting procedure for your machine. See Section 3 for the manufacturer's instructions for starting.

**WARNING**

To prevent personal injury do not operate the loader without lowering the safety bar, fastening the seat belt and keeping feet on the control pedals or cab floor.

IMPORTANT

This engine is equipped with glow plugs. Do not use ether or any high energy fuels to assist starting.

2...CONTROLS

2...CONTROLS

- 2. 1 Instrument Panel
- 2. 2 Seat and Seat Belt
- 2. 3 Seat Bar
- 2. 4 Parking Brake
- 2. 5 Throttle Control
- 2. 6 Lift Arm Supports
- 2. 7 Steering Controls
- 2. 8 Hand Controls
- 2. 9 Electric Solenoid Auxiliary
- 2. 10 Foot Pedals
- 2. 11 Quick - Tach
- 2. 12 Electrical Panel

2...CONTROLS

2.1 INSTRUMENT PANEL

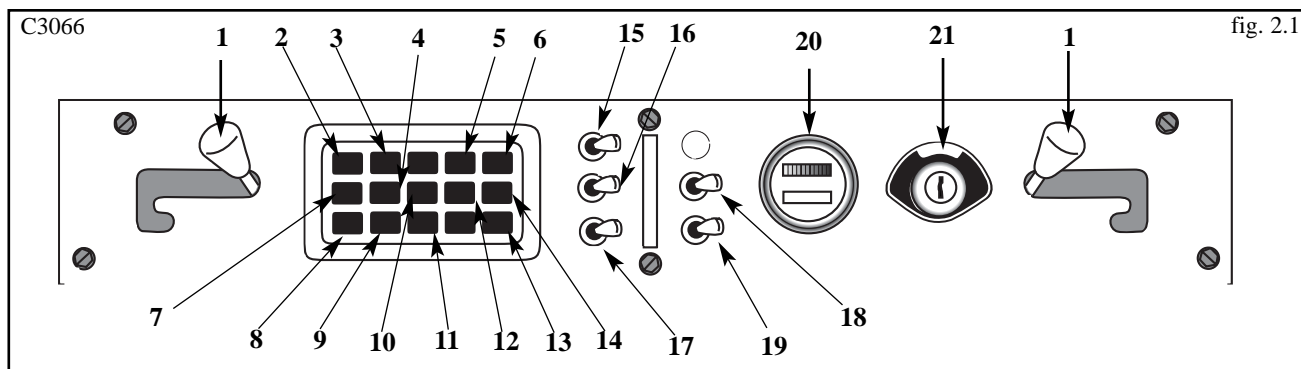

1. **Lift Arm Supports:**
For safety while performing service or maintenance, the loader is equipped with a lift arm support device. Refer to section 2.6 for details.
2. **Left Signal Indicator Light:**
This light will illuminate when the operator uses the optional left signal (if equipped).
3. **Auxiliary Front Indicator Light:**
This light will illuminate when the loader auxiliary hydraulic front switch (if equipped) is turned on.
4. **Brake Indicator Light:**
The brake light will illuminate when the parking brake is engaged.
5. **Work Light Indicator:**
This light will be illuminated when the loader headlights are turned on. This will serve as a reminder to turn them OFF when the loader is not in use.
6. **Right Signal Indicator Light:**
This light will illuminate when the operator uses the optional right signal (if equipped).
7. **Hydraulic Oil Temperature Indicator:**
This light will illuminate when the oil temperature has exceeded recommended levels. Shut off the engine immediately and determine the cause.
8. **Hydraulic Oil Pressure Indicator Light:**
This light will illuminate when there is low hydraulic oil pressure. If this light illuminates, shut off the engine and determine the cause.
9. **Coolant Temperature Indicator Light:**
This light will illuminate if there is a rise in engine temperature. If this occurs, shut off the engine immediately and determine the cause.
10. **Seat Belt Indicator Light:**
This light will illuminate when the seat belt is unfastened.
11. **Alternator Indicator Light:**
This light will illuminate when the alternator is not producing sufficient current.
12. **Engine Oil Pressure Indicator:**
This light will illuminate when the engine loses lubrication pressure. Shut off the engine immediately and determine the cause.
13. **Pre-heat Indicator Light:**
This light will illuminate when the ignition key is turned counter clockwise to activate the engine glow plugs.
14. **Rotary Beacon Indicator:**
This light will illuminate when the optional rotary beacon (if equipped) is turned on.
15. **Hazard Light Switch:**
This switch is a toggle switch. Push up to turn the optional hazard light (if equipped) on.
16. **Rotary Beacon Light Switch:**
This switch is a toggle switch. Push up to turn the optional rotary beacon light (if equipped) on.
17. **Dipped Beam Light Switch:**
This switch is a toggle switch. Push up to turn the work lights on. The light is located on the front of the loader.
18. **Auxiliary Hydraulics Front Switch:**
This switch is a toggle switch. Push up to provide a continuous flow of hydraulic oil to the quick couplers when using an attachment.

IMPORTANT This engine is equipped with glow plugs. Do not use ether or any high energy fuels to assist starting.

WARNING To prevent personal injury never add fuel to the loader when the engine is running or is hot. **NO SMOKING!**

WARNING To prevent personal injury do not start the engine unless you are in the seat with the seat belt fastened around you.

2...CONTROLS

19. Work Light Switch:

This switch is a toggle switch. Push up to turn the optional work light (if equipped) on. The light is located on the back of the loader.

20. Fuel Gauge/Hour Meter:

The fuel gauge indicates the quantity of fuel remaining in the fuel tank. The hour meter records the number of engine operating hours and has a total of 9999.9 hours.

21. Ignition Switch:

The ignition switch is a four (4) position switch: 'OFF', 'PRE-HEAT', 'RUN' and 'START'.

Turn

the key counter clockwise to engage engine 'PRE-HEAT'. Turn the key clockwise to the 'START' position, this engages the starter. The key will be in the 'RUN' position when released. Turn the key to 'OFF' to shut off the engine and remove the key.

2.2 SEAT AND SEAT BELT

The loader is equipped with a deluxe seat. The seat can be adjusted forward or back for operator comfort. (Fig. 2.2A).

For your safety the loader is equipped with a seat belt. Before starting the loader adjust and fasten the seat belt (Fig. 2.2B) around you. The seat and seat belt also have integrated safety lock switches whereby the operator must be seated in the seat with the belt securely fastened

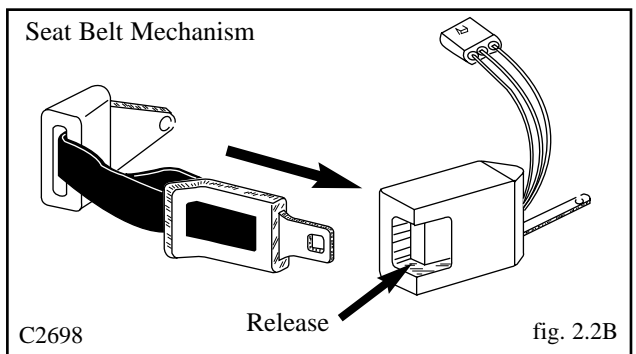
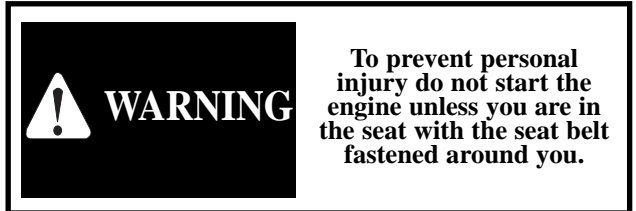

before the loader can be operated.

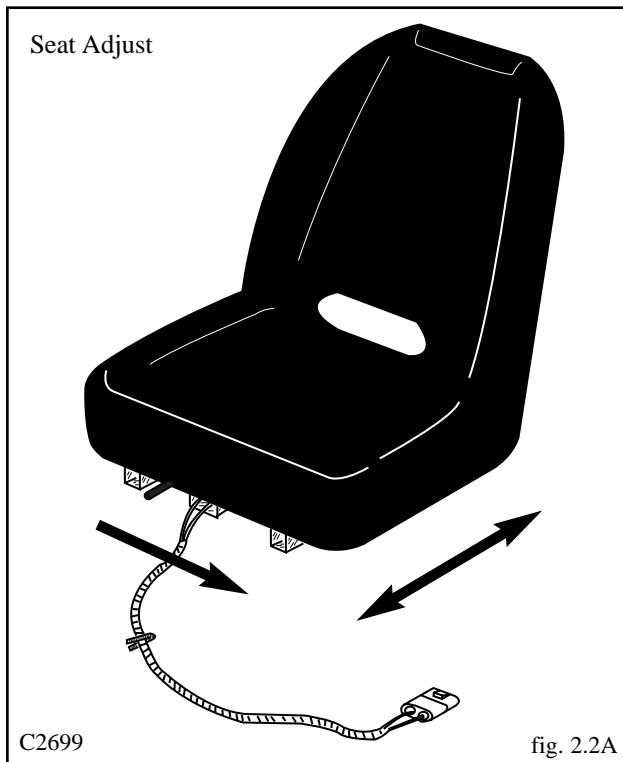

2...CONTROLS

2.3 SEAT BAR

For operator protection the loader is equipped with a seat bar.

To raise the seat bar, lift up on the bar (Fig. 2. 3A). In the up position, the seat bar activates the park brake. Before exiting the loader always check hand control levers by cycling them to be sure they are in the neutral position. The loader must be started with the operator seated in the loader and the seat bar in the up position. When down, the seat bar releases the park brake (Fig. 2. 3C).



2.4 PARKING BRAKE

The loader is equipped with park brakes, located inside the torque motor. The brakes are activated and de-activated by the seat bar, via charge pressure. When the seat bar is in the up position, the brake is activated (Fig. 2.3A). When the seat bar is in the down position, the brake is off (Fig. 2.3C).

The loader has a parking brake indication light to warn that the brake is engaged. When the seat bar is in the down position, activation of the **emergency brake** can be carried out by pushing on the button (optional), located on the ROPS in front of the Left Control Handle.

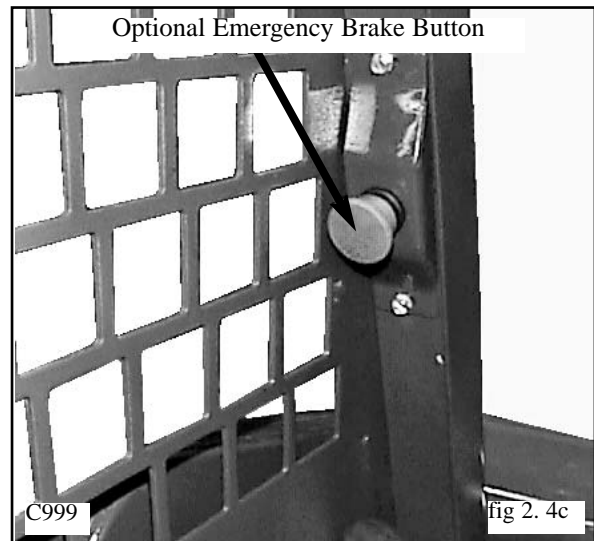

**WARNING**

To avoid personal injury, lower the lift arms, shut off the engine, raise the seat bar and cycle the hydraulics to ensure they are locked. Then, unlatch the seat belt and exit the loader. Do not enter or exit with the engine running unless as specified in this manual or under specific service and backhoe operating procedures.

**WARNING**

To avoid personal injury do not enter or exit the loader with the engine running unless as specified in this manual or under service procedures and backhoe operation.

2...CONTROLS

2.5 THROTTLE CONTROL

The diesel engine throttle control, is the lever located on the left hand side of the loader next to the steering control lever (Fig. 2. 5A) Engine start and stop are controlled electrically by the ignition *key*. (FIG. 2. 5B)

Before shutting off the engine, return the throttle control to idle position and allow the engine to cool at least 2 minutes. Pushing the lever full forward increases the engine speed to maximum high idle. Pulling the lever back decreases the engine RPM.

The engine should always be operated at full speed and the loader travel speed controlled with the steering control levers. (See section 2. 7)

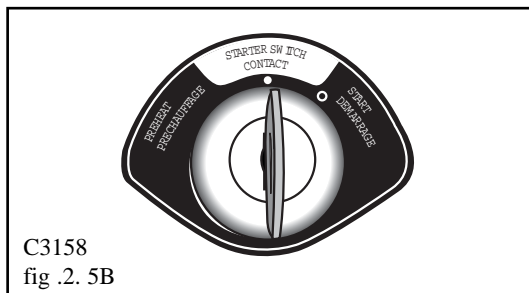
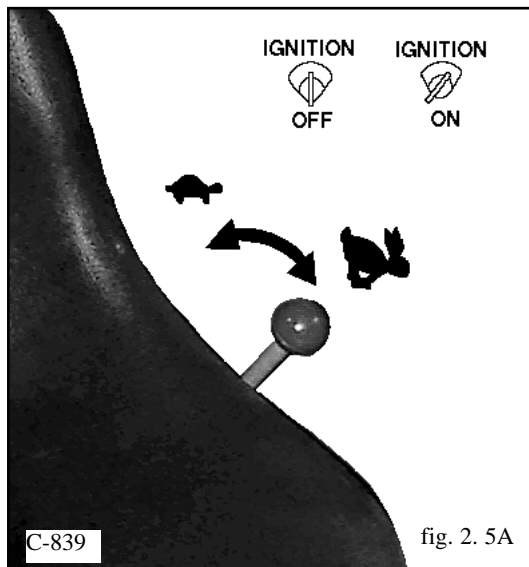

WARNING

To avoid personal injury, lower the lift arms, shut off the engine, raise the seat bar and cycle the hydraulics to ensure they are locked. Then, unlatch the seat belt and exit the loader. Do not enter or exit with the engine running unless as specified in this manual or under specific service and backhoe operating procedures.

2.6 LIFT ARM SUPPORTS

For safety while performing regular service or maintenance work, the loader is equipped with lift arm supports.

The lift arm supports, when extended, prevent the lift arms from dropping if hydraulic pressure is relieved or the foot control pedals are accidentally cycled.

To operate the lift arm supports, first remove any bucket or attachment from the quick-tach; raise the lift arms to full height and shut OFF the engine. Raise the lift arm support handles (Fig. 2. 6A) up and push out toward lift arms to extend the lift arm supports. (Fig. 2. 6B)

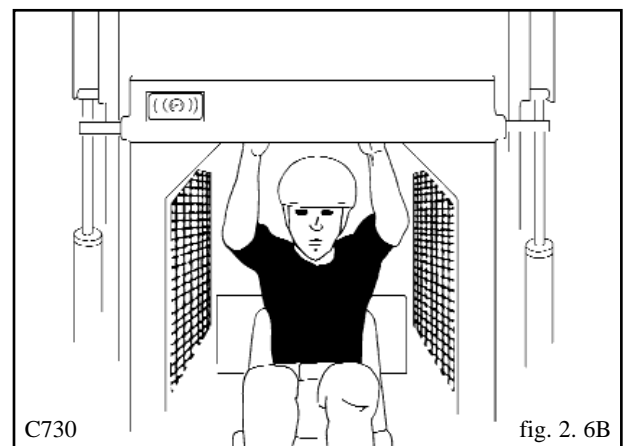
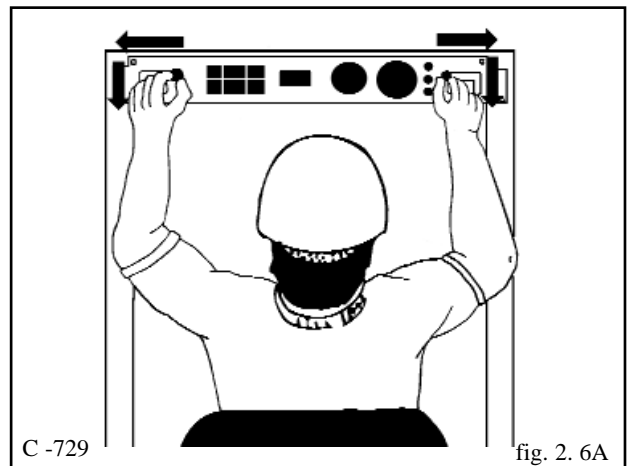

IMPORTANT

Fully retract the lift arm supports before raising or lowering lift arms.

2...CONTROLS

2.7 STEERING CONTROLS

The two steering levers control speed, direction and turning the loader. The R.H. lever controls the wheels on the R.H. side of the loader and the L.H. lever controls the wheels on the left hand side of the loader. The loader speed is controlled by the amount each lever is moved from centre or neutral position. (Fig. 2. 7A) The further away from neutral the faster the travel speed. For maximum power and slow travel speed move the control levers only a small amount. To drive the loader forward in a straight line, move both control levers forward the same amount. (Fig. 2. 7B)

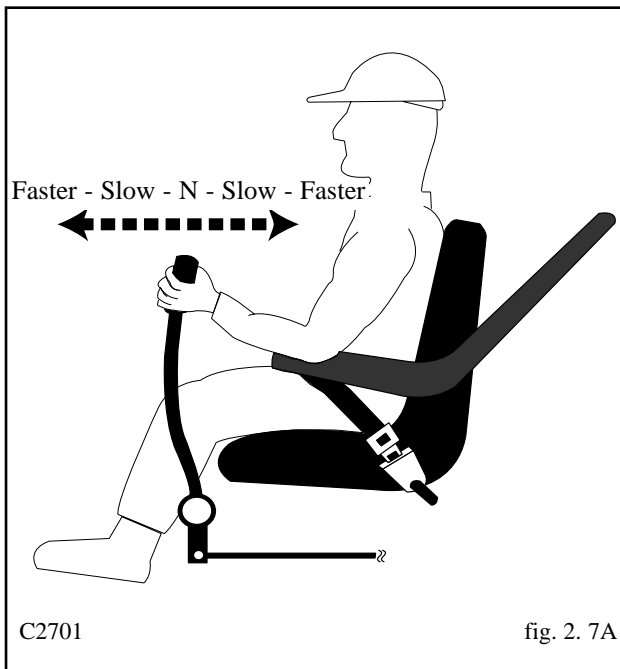

To drive the loader in reverse in a straight line, move both control levers back the same amount (Fig. 2. 7B). The loader is turned by moving one lever further forward than the other. To turn right move the left lever further than the right lever, to turn left move the right lever further than the left lever. For the loader to turn or "skid-steer" within its own length, one lever is moved forward and the other back. This causes the wheels on one side to turn forward and the wheels on the other side to reverse turning the loader. (Fig. 2. 7B)

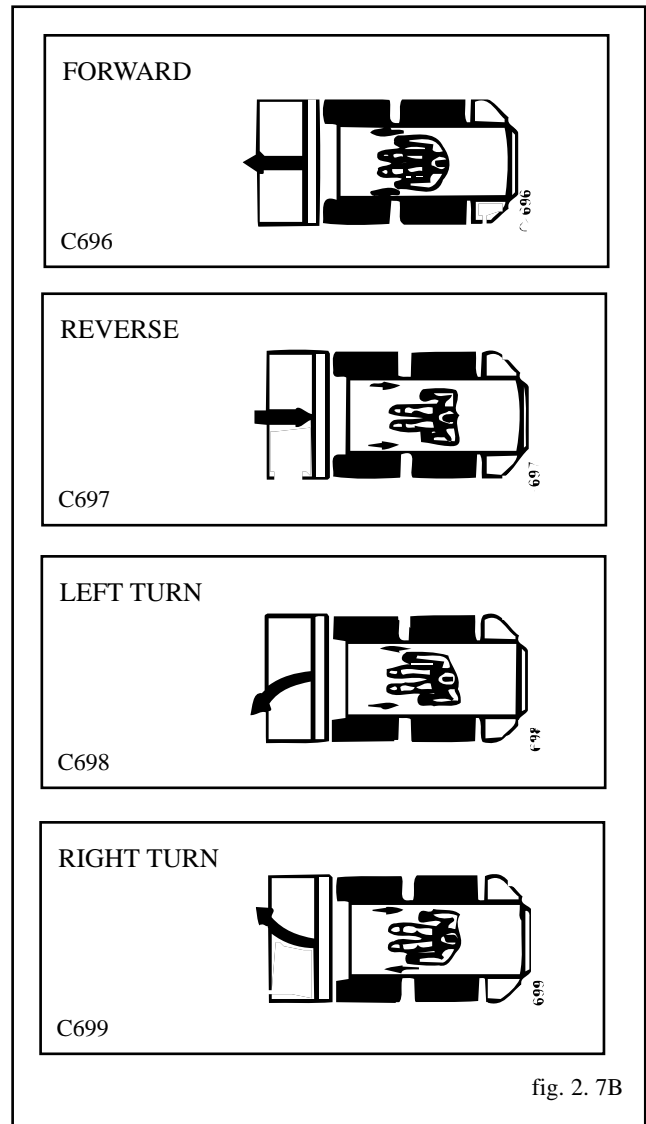

2.8 HAND CONTROLS (OPTIONAL)

Hand controls to operate the loaders lift arm and bucket hydraulic system as well as the loaders travel speed and direction are available. Refer to section 2. 7 for instruction on steering controls.

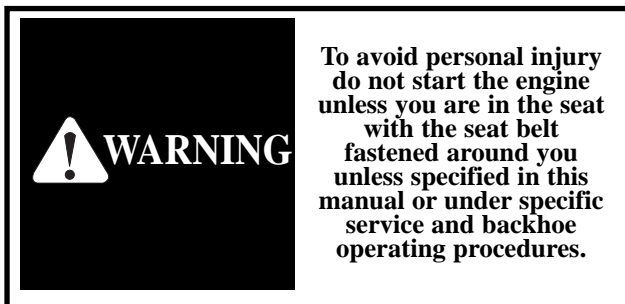

2...CONTROLS

LIFT ARM and BUCKET CONTROLS:

The right hand lever controls the bucket tilt cylinders (Fig. 2. 8A). Moving the left hand control lever to the left will cause the lift cylinders to extend, raising the loaders lift arms. Moving the control lever to the right causes the lift cylinders to retract, lowering the lift arms. Moving the control lever to extreme right will place the lift arms in float position. This allows the bucket to follow the contour of the ground as the loader moves backward.

When the control levers are released they will automatically return to the neutral position stopping all hydraulic movement and travel speed. Before exiting the loader, shut off the engine and lower the lift arms completely down to the frame and ground the attachment. Raise the seat bar to the locked position. Move both levers to the left and right to ensure the hydraulic controls are locked before you get out of the loader.

AUXILIARY HYDRAULICS:

The foot pedal is used to engage the loaders auxiliary hydraulic circuit to power an attachment such as a post hole auger.

Pressing on the toe of the pedal provides hydraulic flow to the female quick - connect coupling located at the front of the lift arms. Firm pressure on the toe of the pedal will lock it into detent position providing a continuous flow of hydraulic oil to the attachment.

Pressing on the heel of the pedal provides hydraulic flow to the quick-connect coupling reversing the flow of hydraulic oil. If not locked in detent position, releasing the pedal will cause it to return to the neutral position stopping all hydraulic flow. Once the pedal is locked in detent, it can be returned to neutral by tapping the heel of the pedal.

When the auxiliary hydraulic system is not in use return the pedal to the neutral position otherwise starting the loader may be difficult or impossible and damage to the starter motor may occur.

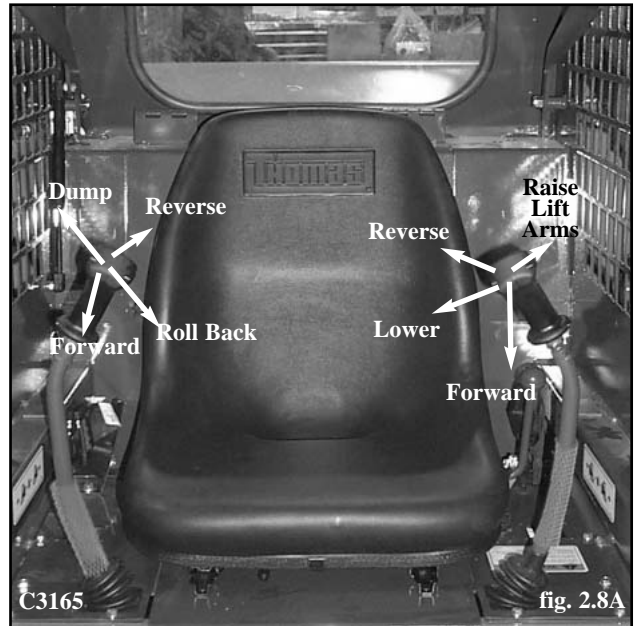

IMPORTANT

Return the auxiliary hydraulic foot pedal to neutral position when not in use.

WARNING

To prevent personal injury do not start the engine unless you are in the seat with the seat belt fastened around you.

2...CONTROLS

2.9 ELECTRICAL SOLENOID AUXILIARY (OPTIONAL)

A switch located in the L.H. steering control lever (Fig. 2. 9A) is used to engage the loaders auxiliary hydraulic circuit to power attachments such as post hole augers, sweepers etc.

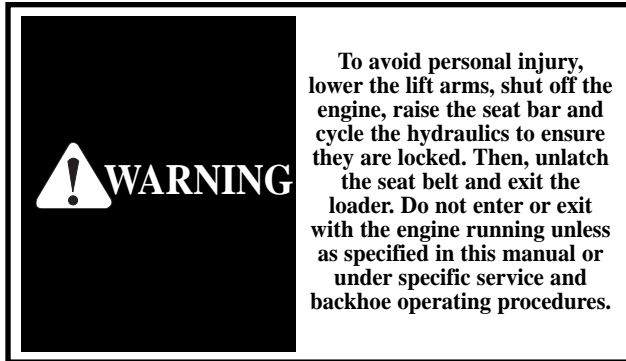

CONTROLS:

By pressing and holding the switch in position 1 (Fig. 2. 9A) provides hydraulic flow to the female quick connect coupling located at the front of the lift arms (Fig. 2. 9B). Releasing the switch returns the auxiliary hydraulic circuit to neutral, stopping hydraulic flow.

By pressing and holding the switch in position 2 (Fig. 2. 9A) provides hydraulic flow to the male quick connect coupling located at the front of the lift arms (Fig. 2. 9B). Releasing the switch returns the auxiliary hydraulic circuit to neutral, stopping hydraulic flow.

For continuous flow to the auxiliary hydraulic circuit, a toggle switch is located on the Instrument Panel. Placing the switch in the ON position provides continuous hydraulic flow to the female quick connect coupling located at the front of the lift arms (Fig. 2. 9B). To stop hydraulic flow to the auxiliary hydraulic circuit, return the switch to the "OFF" position. When the switch on the instrument panel is in the ON position, the switch located in the L.H. control lever is not operable.

NOTE: The optional left hand control lever auxiliary control switch operates a horn, if equipped.

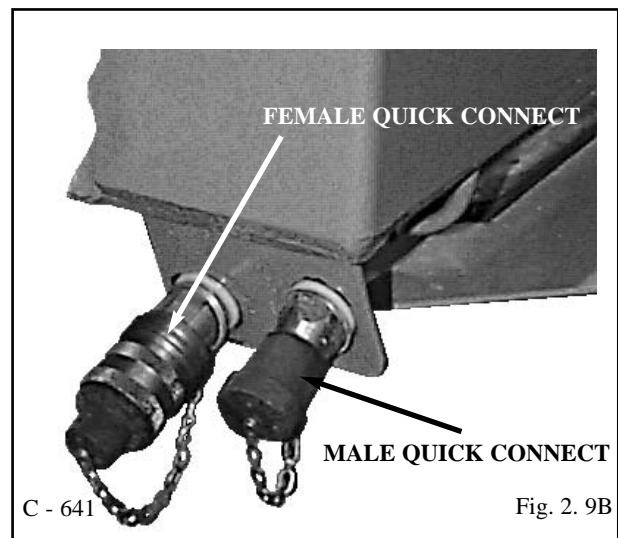
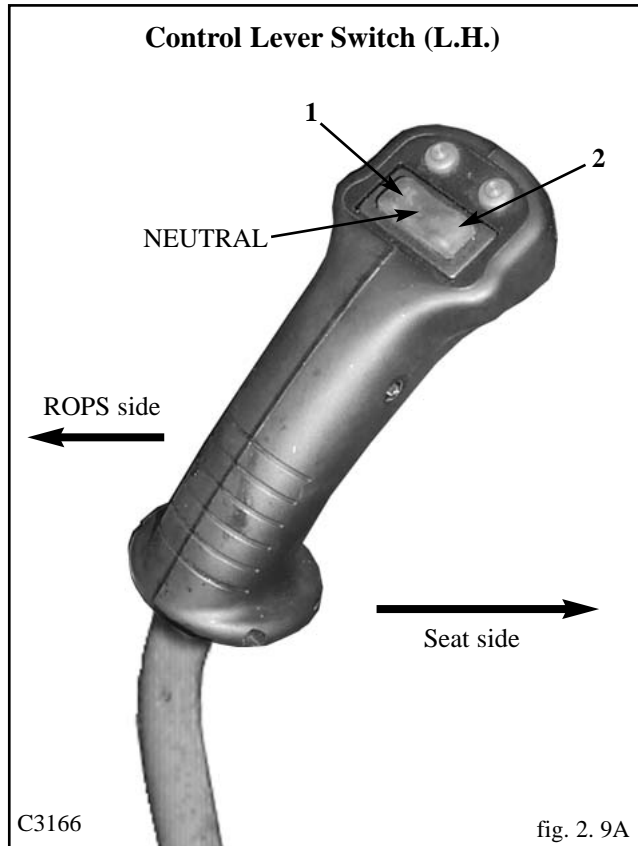

2...CONTROLS

When the auxiliary circuit is not in use and before starting the loader, ensure the switch located in the instrument panel is in the off position, otherwise starting the loader may be difficult or impossible and damage to the starter may occur. If for any reason the loader stops or loses current when the electric solenoid is engaged, it can be disengaged by simply turning off the switch located in the upper panel, or by depressing the poppet located at either end of the control valve (Fig. 2.9B).

IMPORTANT

Return the auxiliary control switch to OFF when not in use otherwise starting may be impossible and damage to the starter may occur. Return toggle switch to neutral.

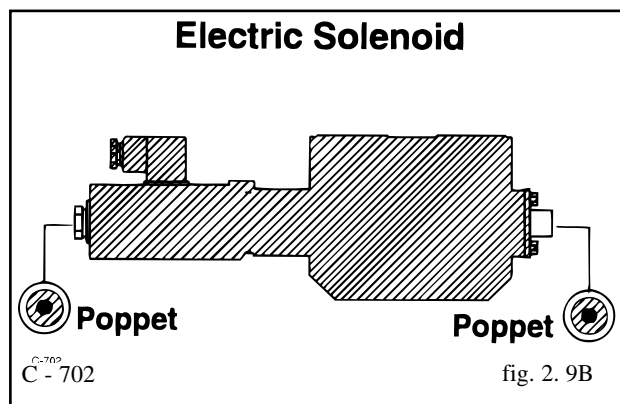

2.10 FOOT PEDALS

Operation of the lift cylinders, bucket tilt cylinders and auxiliary hydraulic circuit are controlled by foot pedals (Fig. 2.10) connected to a hydraulic control valve. The hydraulic control valve is a series type valve which allows simultaneous use of both the lift and bucket tilt circuits.

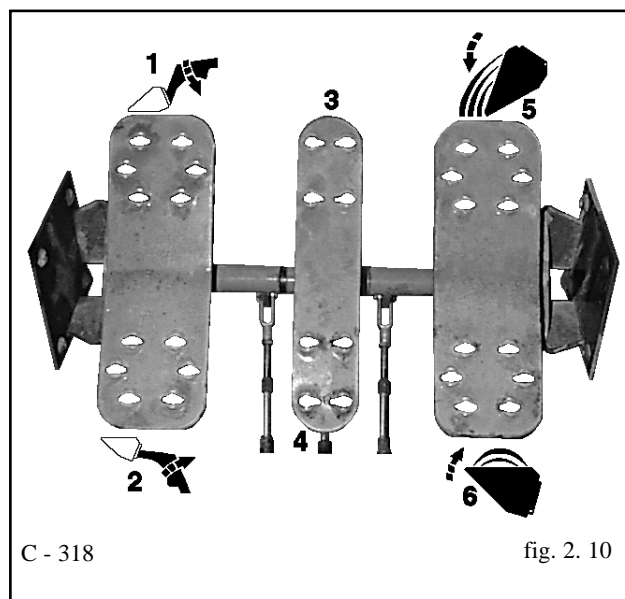

WARNING

To avoid personal injury, lower the lift arms, shut off the engine, raise the seat bar and cycle the hydraulics to ensure they are locked. Then, unlatch the seat belt and exit the loader. Do not enter or exit with the engine running unless as specified in this manual or under specific service and backhoe operating procedures.

Lift – The L.H. pedal is the lift control (Fig. 2.10). To raise the lift arms press on the heel (2) of the pedal. To lower the lift arms press on the toe (1) of the pedal. Firm pressure on the toe (1) of the pedal will lock the lift arms in float position. This allows the bucket to follow the ground as the loader moves backward.

Auxiliary Hydraulics – The center pedal is used to engage the auxiliary hydraulic circuit to power an attachment such as a backhoe. Pressing on the toe (3) of the pedal provides hydraulic pressure to the female quick - connect coupling located at the front of the lift arms. Firm pressure on the toe (3) of the pedal places the valve in detent position providing a continuous flow of hydraulic oil to the attachment. Pressing on the heel of the pedal (4) provides hydraulic pressure to the male quick-connect coupling reversing the flow of hydraulic oil. When the auxiliary circuit is not in use return the foot pedal to neutral position otherwise starting the loader may be difficult or impossible and damage to the starter may occur.

Bucket Tilt – The R.H. pedal is the bucket tilt (dump) control. Pressing on the toe (5) of the pedal will dump the bucket. Pressing on the heel (6) of the pedal will roll the bucket back.

IMPORTANT

Return auxiliary hydraulic foot pedal to neutral position when not in use.

2...CONTROLS

2. 11 QUICK - TACH

The loader is available with a **Hyundai Quick - Tach**. The **Hyundai Quick - Tach** is designed to fit **Hyundai** approved attachments.

The quick - tach, which is standard equipment, allows changing from one attachment to another quickly without having to remove bolt or pins. To operate, simply lift the two over - centre locking levers to disengage the lock pins (Fig. 2. 11B). Tilt the quick-tach frame forward (Fig. 2. 11A) with the bucket tilt cylinders and drive into the attachment. Retract the bucket tilt cylinders which will line up the bottom of the attachment with the quick-tach lock pins. Shut

off the engine. Push the locking levers down (4) (Fig. 2. 11B) extending the lock pins (5) through the attachment. Before operating the attachment check that the locking pins are correctly engaged.

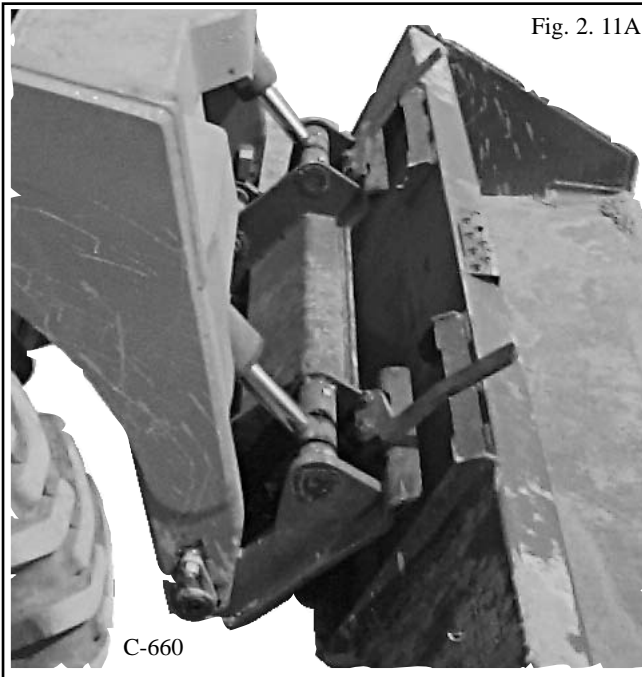

Fig. 2. 11A

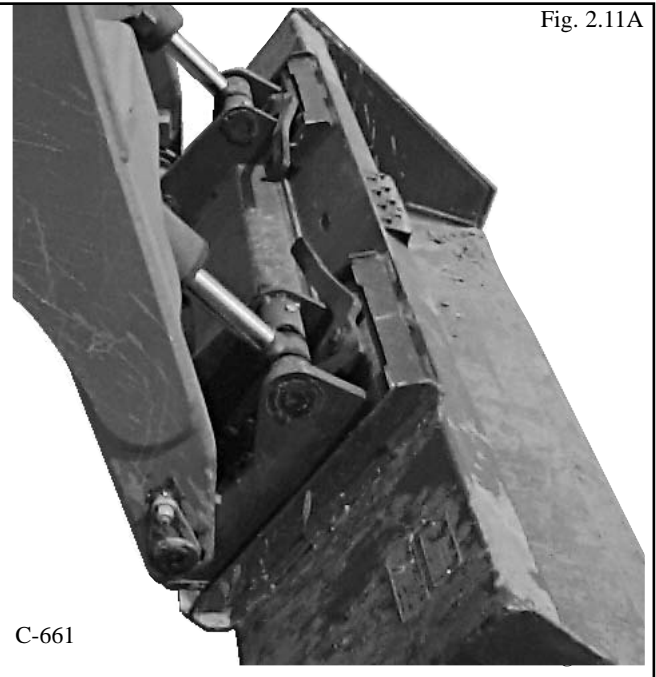
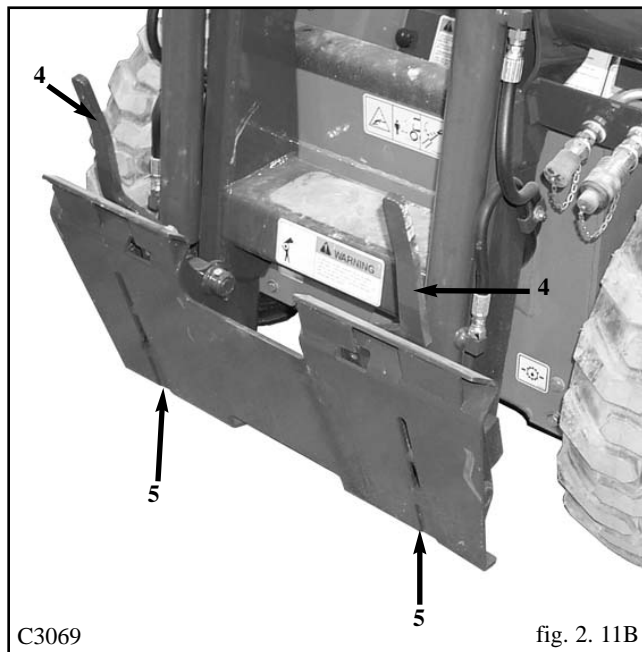
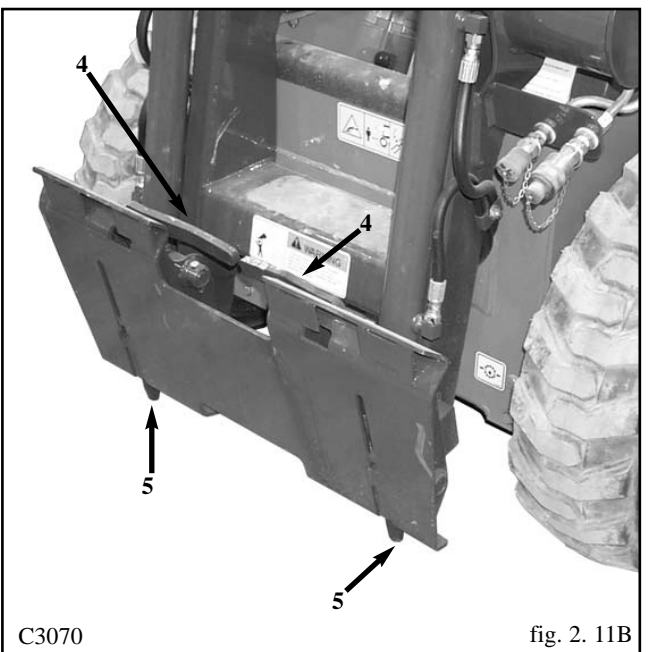

Fig. 2.11A



C3069

fig. 2. 11B



C3070

fig. 2. 11B

2...CONTROLS

2. 12 ELECTRICAL PANEL

The loader is equipped with a 12 volt, negative ground electrical system. The fuse and relay panel is located in the engine compartment just in front of the battery box. The panel consist of the following:

1. Glow Plug Relay
2. Starter Relay
3. Fan Relay
- 4 Main Electrical Circuit Breaker

FUSE PANEL

- | | | | |
|----|--------------------------|-----|--------------------|
| 5. | Valve Locks / Park Brake | 9. | Horn |
| 6. | Fan | 10. | Solenoid Auxiliary |
| 7. | Electric Fuel Shutoff | 11. | Alternator |
| 8. | Spare | 12. | Spare |

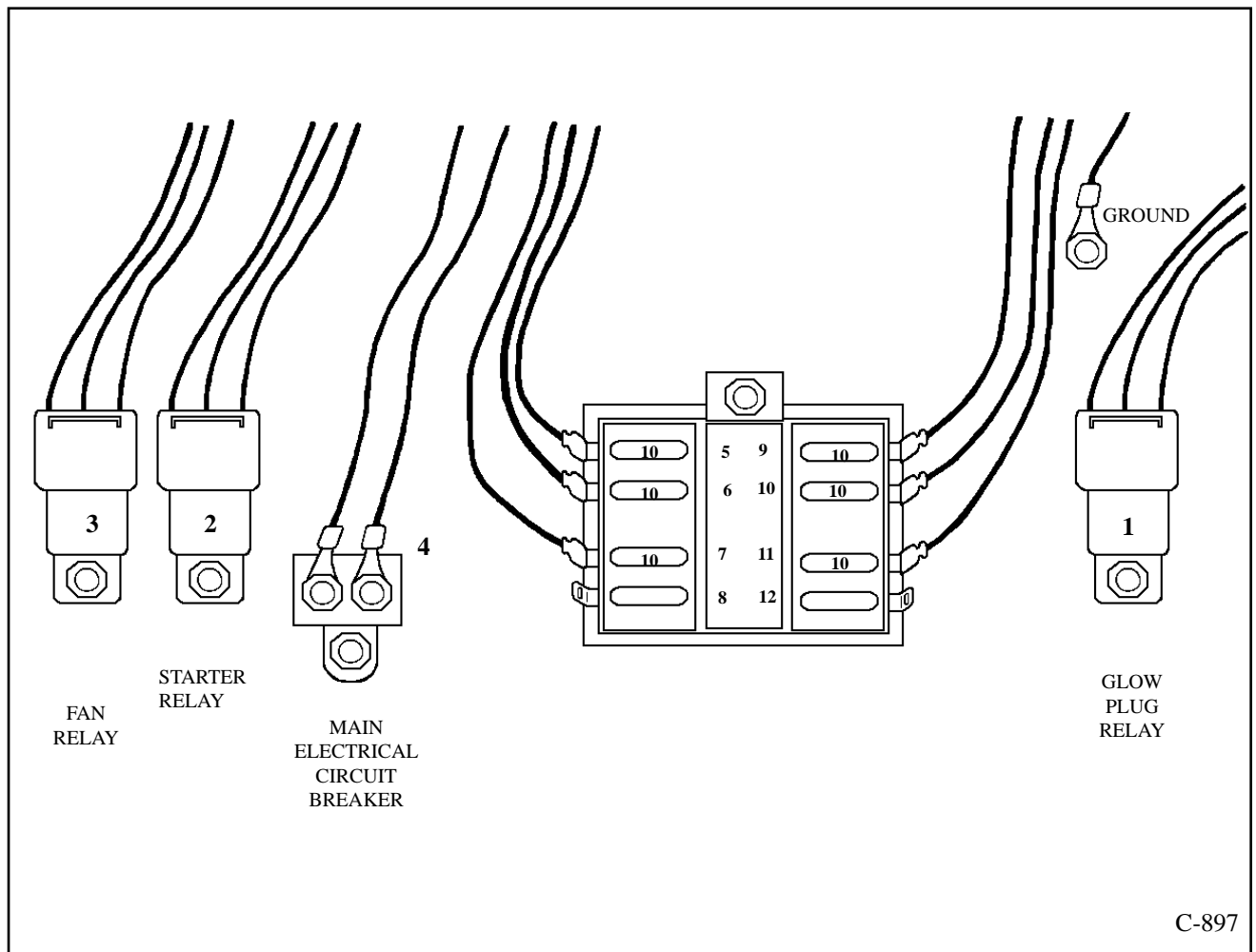

3...OPERATION

3...OPERATION

- 3. 1 Starting Instructions
 - A. Pre - Starting Inspection
 - B. Starting Procedure
 - C. Shut - Off Procedure
- 3. 2 Operating Procedure
- 3. 3 Filling From a Pile
- 3. 4 Digging With a Bucket
- 3. 5 Leveling and Backfilling
- 3. 6 Auxiliary Hydraulics
- 3. 7 Lifting
- 3. 8 Towing
- 3. 9 Securing and Transporting
- 3. 10 Battery Maintenance and Boosting
- 3. 11 Lowering Lift Arms

3...OPERATION

3.1 STARTING INSTRUCTIONS

A. Pre-Starting Inspection

Before starting the loader complete the following inspection:

1. Check the hydraulic oil level, engine oil level, engine coolant level and fuel supply.
2. Check the air filter indicator.
3. Check for fuel, oil and hydraulic leaks.
4. Check lights, battery level and cables.
5. Check tire pressure:
8.50 X 15 30 - 35 P.S.I. (207 - 241 kPa)
10.50 x 15 30 - 35 P.S.I. (207 - 241 kPa)
6. Check wheel nut torque 100 - 110 ft. lbs. (136 - 149 Nm)
7. Lubricate all grease fittings.
8. Check the condition and operation of all safety decals and equipment – Ensure all shields and safety screens are in place. If necessary repair or replace before starting.

For complete daily servicing refer to section 4. 2.

B. Starting Procedure – Diesel

1. Ensure the seat bar is in the UP position and the steering controls are centered and the hydraulic controls are locked.

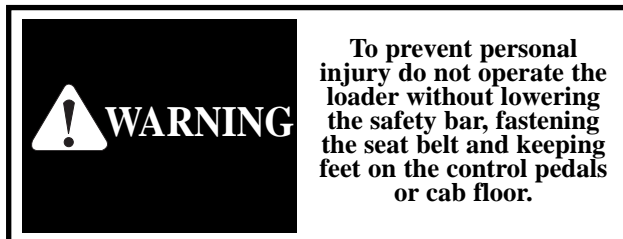

2. Adjust and fasten the seat belt securely around you.
3. Place the throttle control in idle position.
4. Turn the ignition key counter clockwise to activate the glow plugs. Hold approximately 15 seconds. Both the alternator and engine oil pressure warning lights should be on.
5. Turn the key clockwise to start position to engage the starter. Do not crank the starter for more than 15 seconds. If the engine fails to start turn the key counter clockwise and pre - heat again.
6. When the engine has started the engine oil pressure and alternator warning lights should go out. If they don't, shut - off the engine immediately and determine cause. Allow the engine to warm up for five minutes before operating. When ready to operate, lower the seat bar and advance the throttle to full on position.

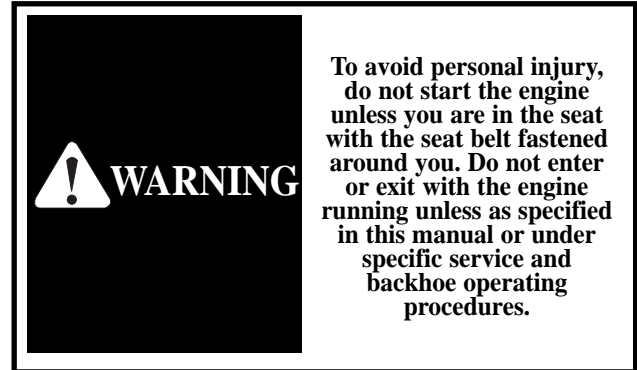

C. Shut-Off Procedure

1. Park the loader on level ground. If it's necessary to park on a slope, position the machine at right angles to the slope.
2. Lower the lift arms and ground the attachment.
3. Return the throttle control to idle position. If the engine is hot allow it to idle until normal. At least 2 minutes.
4. When the engine is cool, turn the ignition key to the OFF position and remove the key.
5. Never enter or exit the loader when the engine is running unless as specified in this manual or under specific service and backhoe operating procedures.
6. Place the auxiliary foot pedal in neutral position. If the auxiliary foot pedal is left in detent, restarting the machine may be impossible. If equipped with an electric solenoid make sure the switch is in the OFF position.
7. Raise the seat bar to apply the park brake. Turn the ignition switch to the OFF position, unfasten the seat belt, and ensure the pedals are locked by rocking them, and ensure the steering levers are in neutral.

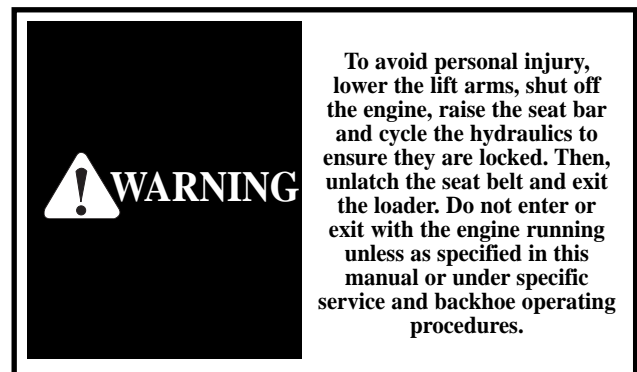

3...OPERATION

3.2 OPERATING PROCEDURES

1. When learning to use the loader operate at a slow rate.
2. Take advantage of the efficient operation of the loader. Keep the travel distance as short as possible. Keep the work area small so the cycle time is short.
3. Keep the work area as level as possible.
4. Decrease cycle time by “skid” turning (section 2.7) rather than a go backward-go forward turn.
5. Fill the bucket to rated capacity. Turning is easier with a full load than with a partial load. Keep the loaded bucket close to the ground when transporting.
6. Tilt the bucket as you raise the lift arms or drive up a slope. This will prevent material from falling off the back of the bucket.
7. Do not drive across a slope. Always go up or down a slope with the heavy end of the loader pointing up towards the top of the slope.

3.3 FILLING FROM A PILE

Push down on the toe of the lift arm pedal and lower the lift arms completely down (Fig. 3. 3A). Push the toe of the bucket pedal and place the cutting edge of the bucket on the ground. For hand control units, move the L.H. control lever towards you and lower the lift arms completely down. Move the R.H. control lever away from you (Fig. 3. 3A) and place the cutting edge of the bucket on the ground.

Drive the loader forward slowly. As the bucket begins to fill push on the heel of the bucket pedal to raise the front of the bucket (Fig. 3. 3B) and push on the heel of the lift arm pedal to raise the lift arms. When the bucket is full back away from the pile. For hand control units, move the R.H. control lever towards you to raise the front of the bucket, and move the L.H. control lever away from you to raise the lift arms (Fig. 3. 3B). When the bucket is full back away from the pile.

IMPORTANT

Always let the engine warm completely before you begin operation each day.

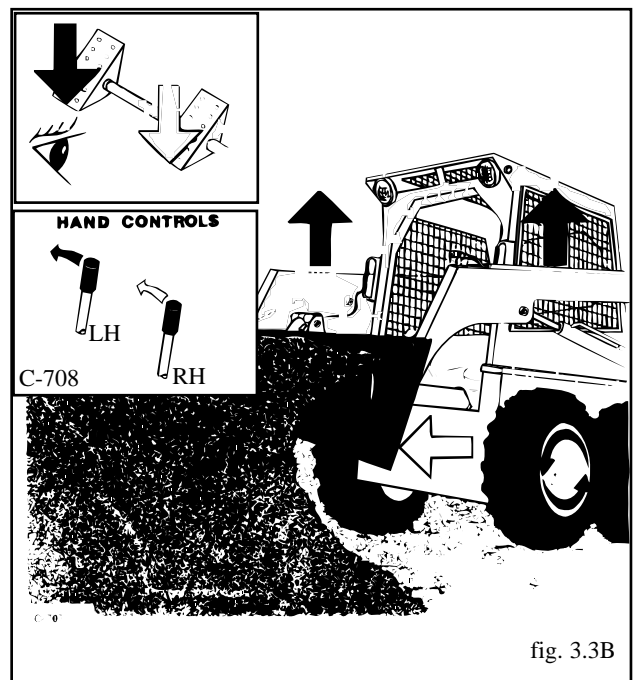
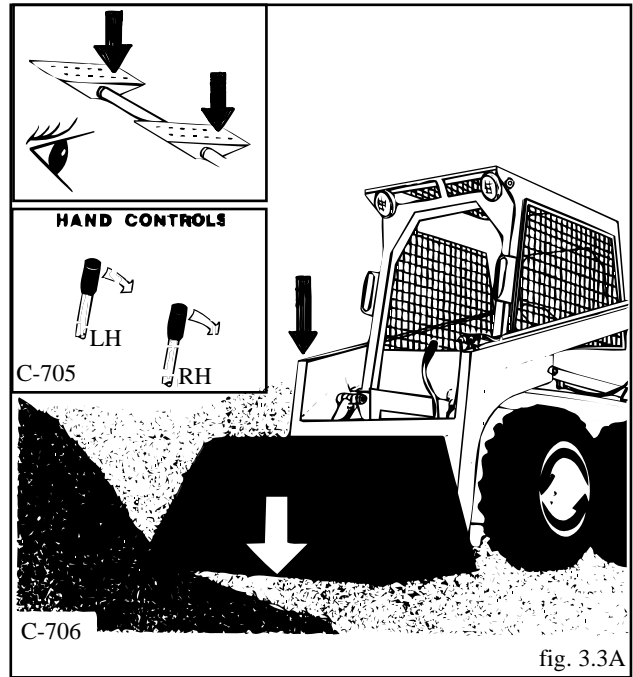

3...OPERATION

To dump the bucket (Fig. 3. 3C) push down on the heel of the lift arm pedal to raise the lift arms. Push down on the toe of the bucket pedal small amounts as the lift arms are raising to stop material from falling off the back of the bucket. When the bucket is at the correct height for dumping, push on the toe of the bucket pedal to empty the bucket.

For hand control units, move the L.H. control lever away from you (Fig. 3. 3C) to raise the lift arms. Move the R.H. control lever away from you in small amounts as the lift arms are raising to stop material from falling from the back of the bucket. When the bucket is at the correct height for dumping, move the R.H. lever away from you to empty the bucket.

3. 4 DIGGING WITH A BUCKET

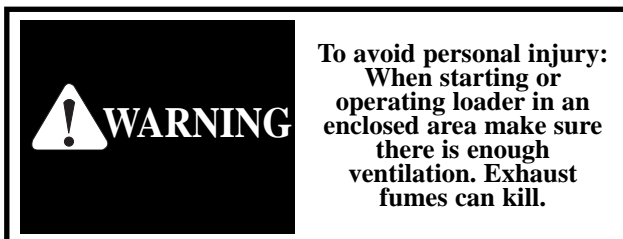
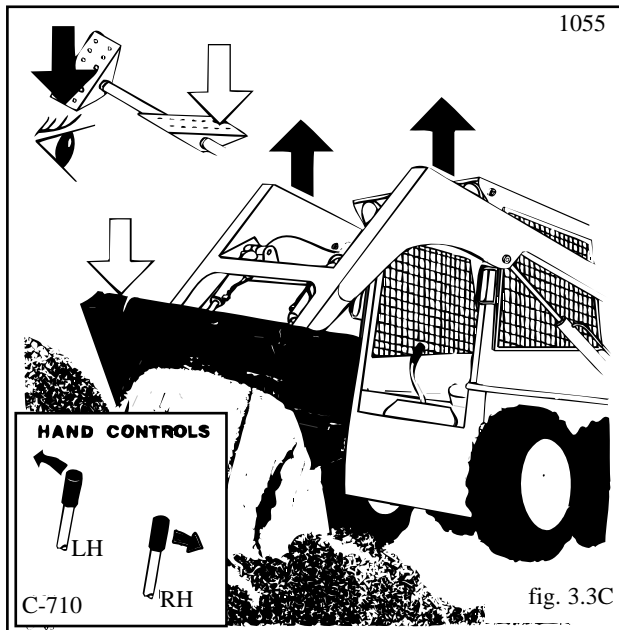

Push on the toe of the lift arm pedal and lower the lift arms completely down. Push on the toe of the bucket pedal and place the cutting edge of the bucket on the ground (Fig. 3. 4D). Drive the loader forward at a slow rate and continue to tilt the bucket down until it enters the ground.

Push down on the heel of the bucket pedal (Fig. 3.4E) to increase traction and keep an even digging depth.

Continue to drive forward until the bucket is full. When digging in hard ground, it is easier to raise and lower the bucket cutting edge with the tilt pedal while slowly driving forward.

When the bucket is full push down on the heel of the bucket pedal (Fig. 3. 4F) to raise the tip of the bucket.

For hand control units, move the L.H. control lever towards you to lower the lift arms completely down. Move the R.H. control lever away from you and place the cutting edge of the bucket on the ground (Fig. 3. 4D). Drive the loader forward at a slow rate and continue to tilt the bucket down until it enters the ground. Move the R.H. control lever towards you (Fig. 3. 4E) to increase traction and keep an even digging depth. Continue to drive forward until the bucket is full. When the bucket is full, move the R.H. control lever towards you (Fig. 3. 4F) to raise the tip of the bucket.

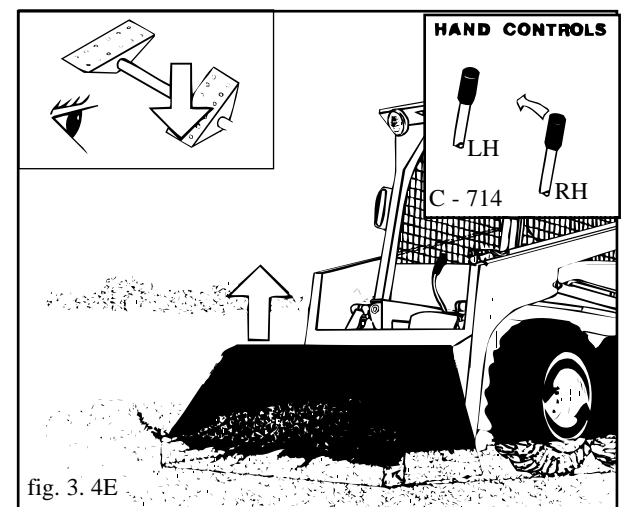
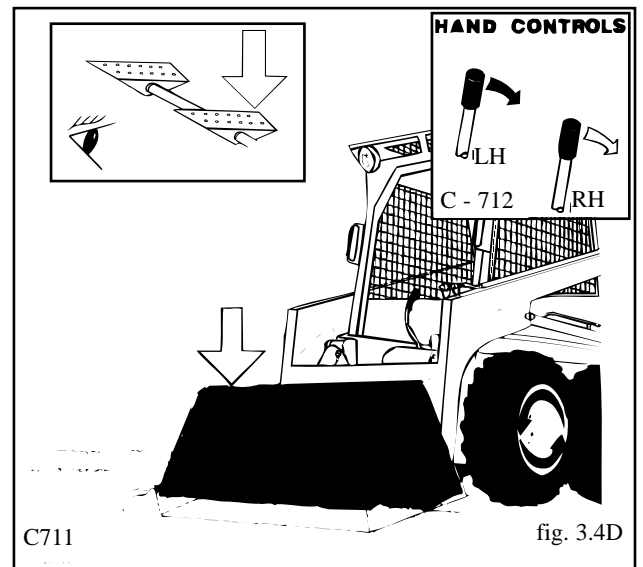

3...OPERATION

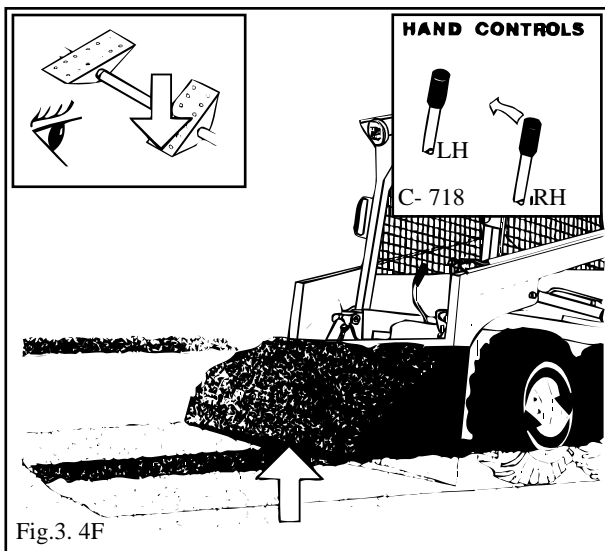
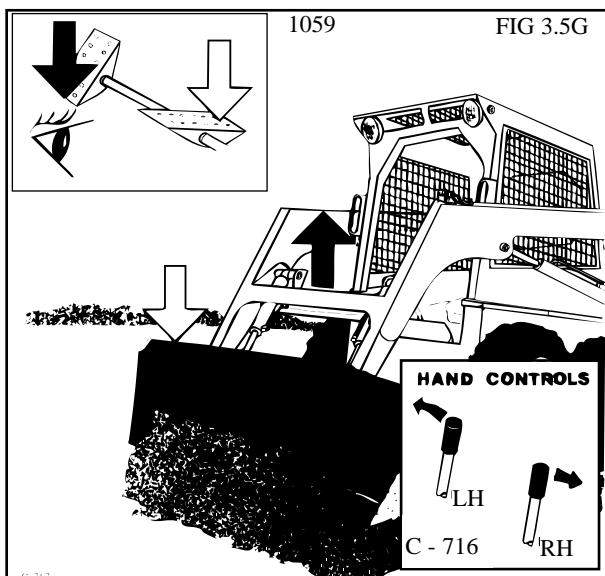

Fig.3. 4F

3.5 LEVELING AND BACKFILLING

Spread dirt on uneven ground by pushing on the heel of the lift arm pedal (Fig. 3.5G) to raise the lift arms and push on the toe of the bucket pedal to tilt the bucket down as you drive forward.

For hand control units, spread dirt on uneven ground by moving the L.H. control lever away from you (Fig. 3. 5G). To raise the lift arms and move the right hand control lever away from you to tilt the bucket down as you drive forward.



1059

FIG 3.5G

To level the ground; raise the lift arms and tilt the bucket down by pressing on the toe of the bucket pedal (Fig. 3.5H). Push firmly on the toe of the lift arm pedal to lock the lift arms in float position. The weight of the lift arms and bucket will hold the bucket on the ground. Drive backward to level material.

To level the ground with a hand control unit, raise the lift arms and tilt the bucket down by moving the R.H. control lever away from you. Move the L.H. control lever all of the way towards you (Fig. 3. 5H) to place the lift arms in the float position. The weight of the lift arms and the bucket will hold the bucket on the ground. Drive backwards to level material.

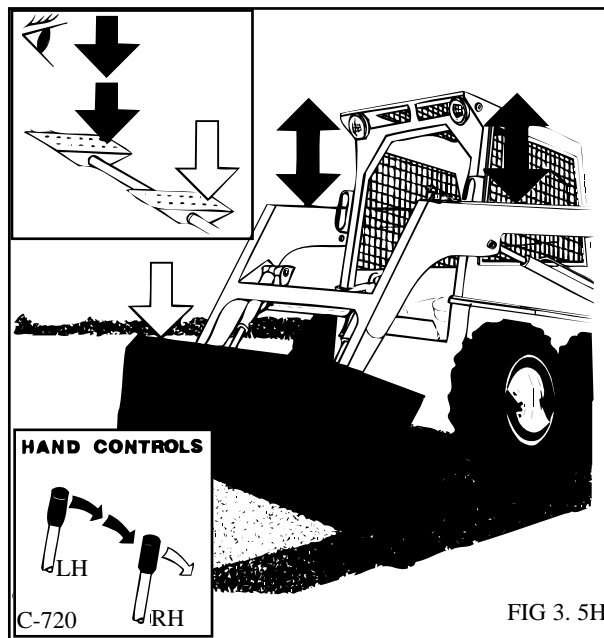

FIG 3. 5H

To fill a hole (Fig. 3. 5I) drive the loader slowly with the bucket low, up to the hole. As the bucket passes the edge of the hole, push on the toe of the bucket pedal to dump the bucket. When necessary raise the lift arms to empty the bucket.

On hand control units, as the bucket passes the edge of the hole, move the R.H. control lever away from you to dump the bucket. When necessary, raise the lift arms to empty the bucket.

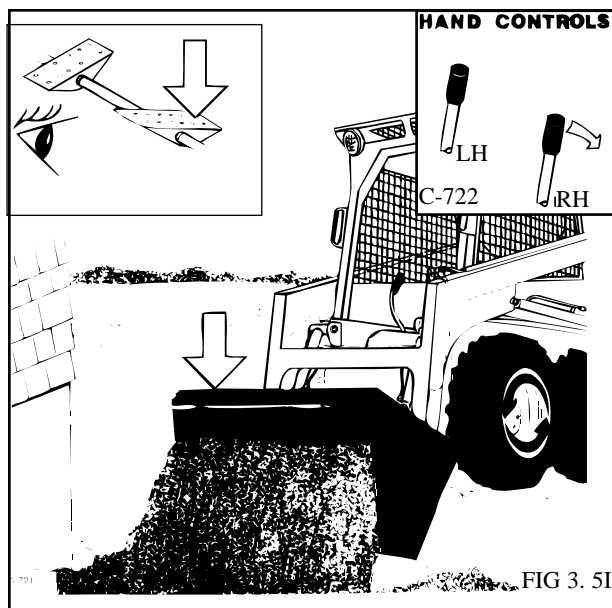
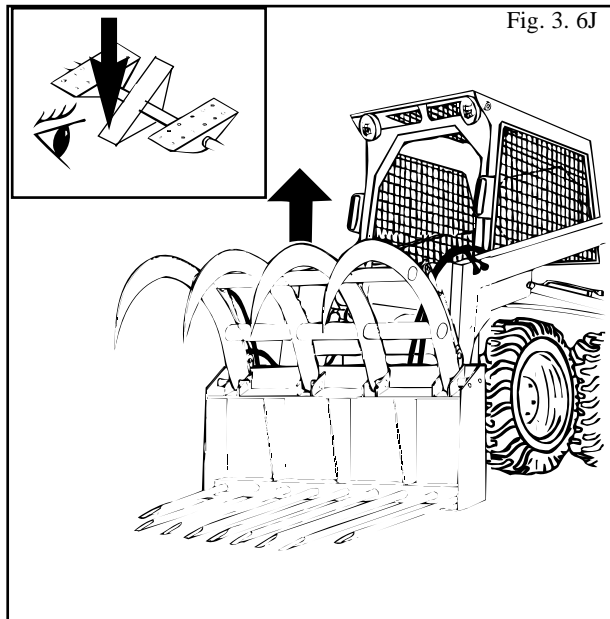

FIG 3. 5I

3...OPERATION

3.6 AUXILIARY HYDRAULICS

To operate an attachment such as a grapple fork using the auxiliary hydraulic circuit, push on the heel of the centre or auxiliary pedal to open the grapple (Fig. 3. 6J).



To close the grapple (Fig. 3. 6K), push down on the toe of the auxiliary pedal. The lift arm and the bucket pedals can be used to raise and tilt the grapple as with a bucket.

To operate an attachment which requires a constant flow of oil such as a sweeper push down firmly on the toe of the

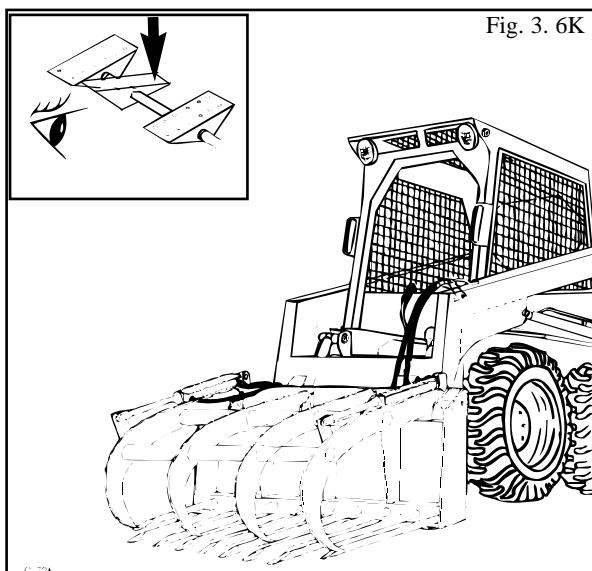

auxiliary pedal until the pedal locks in detent position. When the auxiliary circuit is not in use return the auxiliary pedal to neutral position otherwise starting the loader may be difficult or impossible.

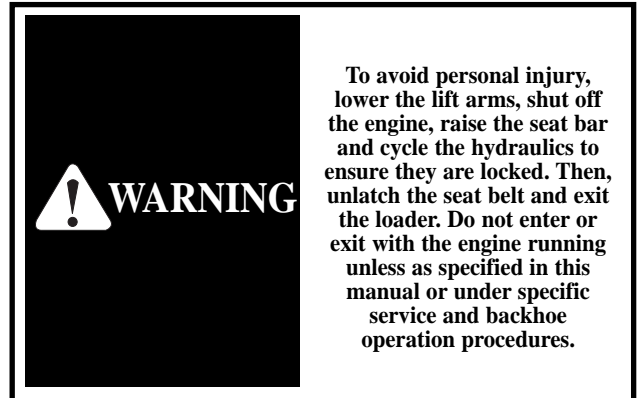

3.7 LIFTING

The loader can be equipped with optional features to use in lifting (for example by crane onto a flatbed trailer or a flat car), for securing, and for extraction (from mud or snow).

To lift using a crane, first follow the shut-off procedure in section 3.1C.

Once this is done, attach properly rated cables, chains or straps to lift points provided (Fig. 3.7). To prevent marking the operator guard or chafing of the lifting cable, a lifting frame should be used.

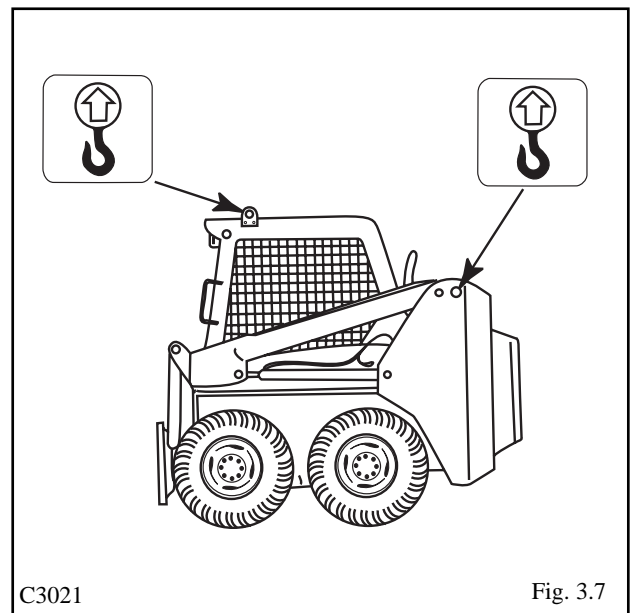

C3021

3...OPERATION



WARNING

To avoid personal injury, lower the lift arms, shut off the engine, raise the seat bar and cycle the hydraulics to ensure they are locked. Then, unlatch the seat belt and exit the loader. Do not enter or exit with the engine running unless as specified in this manual or under specific service and backhoe operating procedures.

3.8 TOWING

1. When winching or towing a stuck loader from the rear, always lower the lift arms until the attachment is resting on the ground and then follow the shut-off procedure (See 3.1C).
2. When winching or towing a stuck loader from the front, lower the attachment so that the front attachment points are accessible and have an assistant block the attachment, then follow the shut-off procedure (See 3.1C).
3. Attach a properly rated chain, cable or towing strap to the towing point provided (Fig. 3.8). The point was designed to accommodate a chain, but a cable or strap with a sufficiently large hook to prevent jamming in the chain slot may be used.
4. If towing from the front, remove the blocks supporting the attachment prior to engaging tow equipment.
5. The attachment point on the towing or winching equipment should be kept as low as possible and in as direct a line as possible with the stuck loader. A steep tow line angle or side pull could result in upsetting the stuck loader.

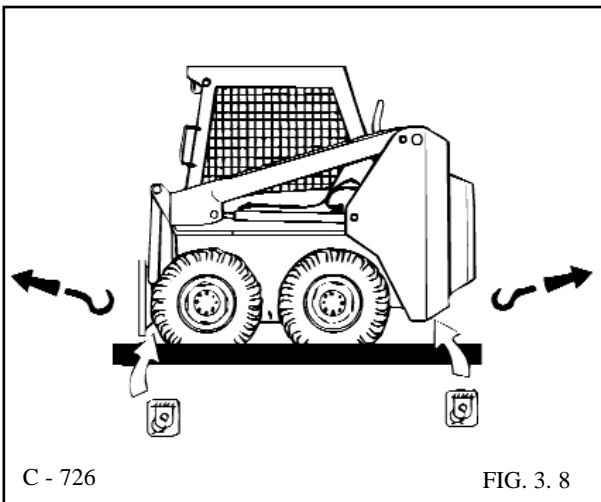

C - 726

FIG. 3. 8

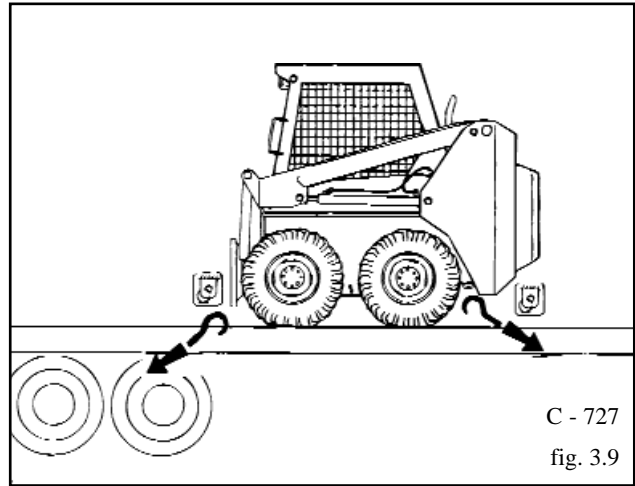

C - 727

fig. 3.9

IMPORTANT

Never install tie down chains across the bucket cylinders. Damage to the cylinders may occur.

3.9 SECURING AND TRANSPORTING

There are three tie down points provided for securing the skid steer while transporting. One at the lower front and two at the rear (fig. 3. 9).

Be sure the trailer and/or truck is of adequate size and capacity to safely transport your skid steer.

Measure the clearance height of the machine and trailer or truck, and post it in the cab of the truck.

Before loading the skid steer make sure the ramps and parking surface are free of all oil, grease, ice, etc. and of sufficient strength to support the load.

IMPORTANT

When moving your skid steer on or off a transport vehicle, drive slowly and keep the machine centered.

Know the local rules and regulations, and make sure your truck and trailer is equipped with the correct safety equipment.

When loading a skid steer with an attachment, always load the heavy end of the skid steer first.

Once the skid steer has been loaded, lower the attachment to the floor, stop the engine and engage the park brake.

Install chains at the front and rear tie down locations, and securely attach to the transport vehicle.

NOTE: Minimum 3/8 in. grade 40 chain is required

3...OPERATION



3.10 BATTERY MAINTENANCE AND BOOSTING

Inspect the battery on a regular basis for damage such as a cracked or broken case or cover which would allow electrolyte loss.

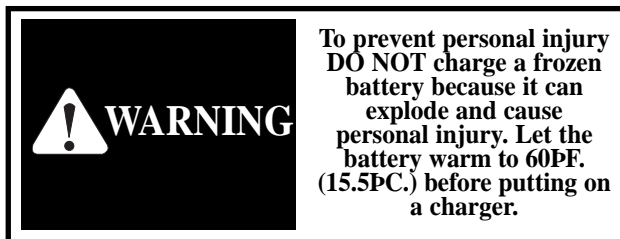
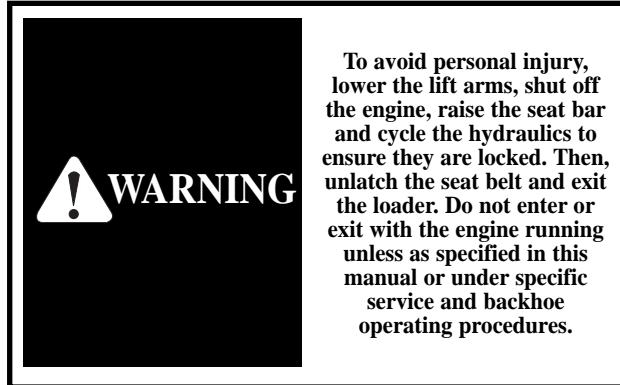

Check the battery cables for tightness and that they are corrosion free. Remove any acid corrosion from the battery and cables with a baking soda and water solution. Coat the terminal connections with di-electric grease.

If it is necessary to use a booster battery to start the engine, **BE CAREFUL !**

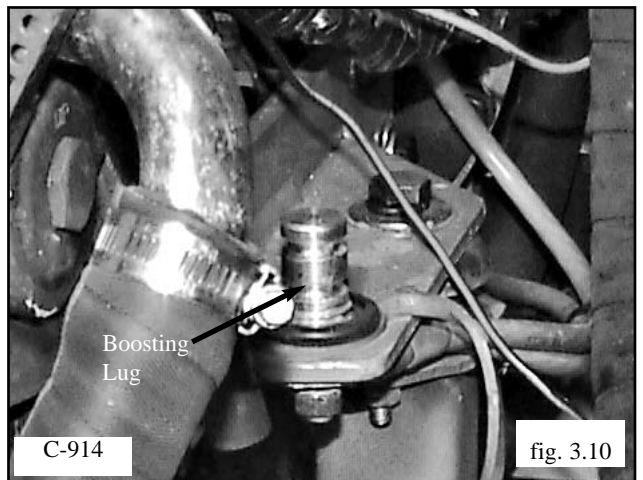
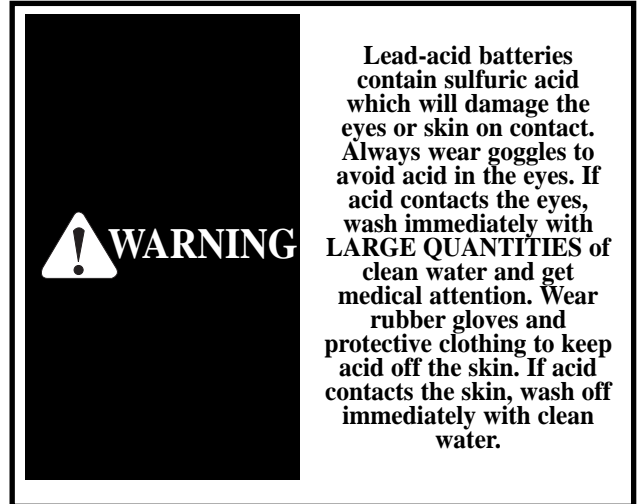

The ignition must be in the OFF position. The booster battery to be used must be 12 volt. Connect the end of the first cable to the positive (+) terminal of the booster battery. Connect the other end of the same cable to the loader battery positive (+) terminal, or to the boosting lug. (See Fig 3. 10). Connect the end of the second cable to the negative (-) terminal of the booster battery. Connect the other end of the same cable to a ground. Keep cables away from moving parts. Start the engine. After the engine has started, disconnect the end of the second cable from the negative (-) terminal of the booster battery. Disconnect the other end of the same cable from the ground. Disconnect the end of the first cable from the positive (+) terminal of the booster battery. Disconnect the other end of the same cable from the loader battery positive (+) terminal, or boosting lug. (See Fig 3. 10).

3... OPERATION

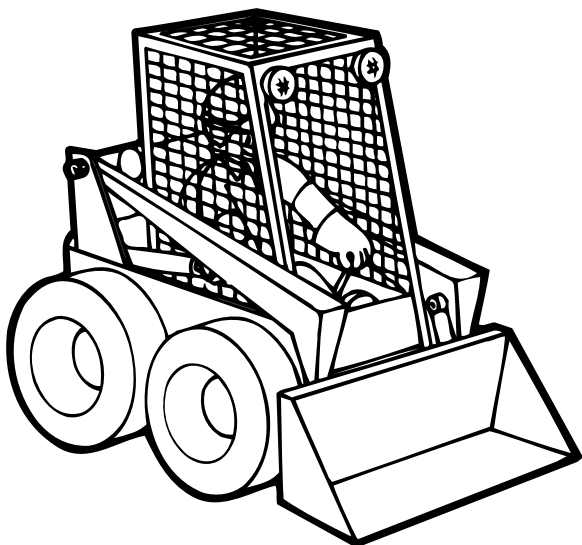

C-361

Safe Shutdown Procedures

- Stop machine
- Lower the bucket and other attachments flat on the ground
- Position controls in neutral
- Idle engine for short cool-down period
- Stop engine
- Cycle hydraulic controls to eliminate pressure
- Raise operator seat bar
- Check that lift arm/bucket controls are locked in neutral
- Unbuckle seat belt
- Remove ignition key and lock covers and closures

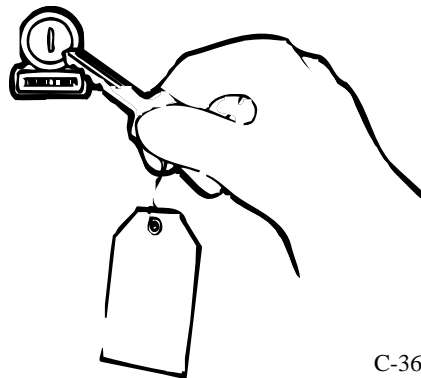

C-362

Don't give anyone the key to an accident.

3...OPERATION

3. 11 LOWERING LIFT ARMS (ENGINE OFF)

In the event that you should have an electrical failure which renders your skid steer inoperable with the lift arms up, the following procedures would apply.



1. Lift Arm Height Is Sufficient To Engage Lift Arm Support Pins

Engage lift arm support pins. (Fig. 3. 11A) Raise seat bar and cycle all controls to ensure they are locked. Exit loader and open rear door. Locate the control valve on the right side of the machine. Unplug the electrical wire and remove the knurled nut holding the solenoid on the spool lock. Remove the solenoid, then remove the lock pin and spring assembly. (Fig. 3. 11B2) Once the lock pin and spring are removed, the lift arm spool is free to travel. Enter the machine, being careful not to cycle the foot pedals or the control levers as the locking system has been disabled. Once in the operator seat, lower the safety bar, and disengage lift arm support pins. Move the lift arm pedal or control lever to lower the lift arms to the ground.

2. Lift Arm Height Is Not Sufficient To Engage Lift Arm Support Pins

DO NOT EXIT FROM FRONT OF LOADER WITHOUT LIFT - ARMS ON GROUND OR SUPPORTED BY ACCEPTABLE MEANS!

Raise seat bar and cycle all controls to ensure they are locked. If help is readily available, have some one place a suitable support under the lift arms (e.g. 4" x 4" Lumber) or a piece of angle iron between lift cylinder end cap and lift cylinder rod mount.

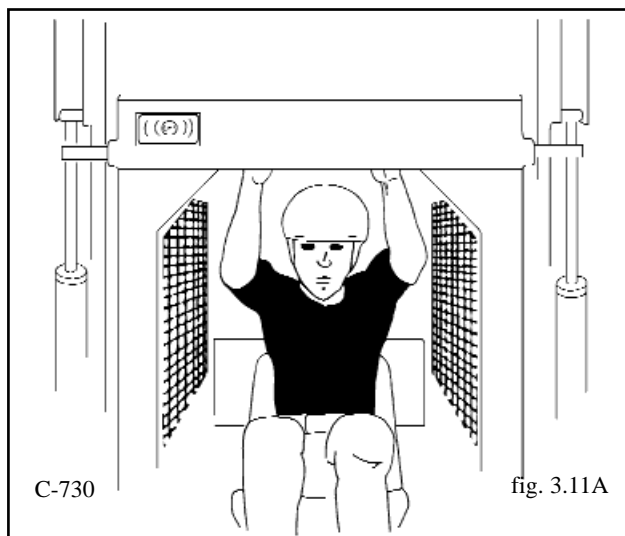

Then exit loader using extreme caution. If help is not available, the operator must exit the loader from the rear window and perform the proper lift arm supporting (As described previously). Once this is completed, open rear door. Locate the control valve on the right side of the machine. (FIG. 3. 11B1) Unplug the electrical wire and remove the knurled nut holding the solenoid on the spool lock. Remove the solenoid, then remove the lock pin and spring assembly (Fig. 3. 11B2). Once the lock pin and spring are removed, the lift arm spool is free to travel.

Ensure assistance is available, then the operator can enter the machine, being careful not to cycle the foot pedals or the control levers as the locking system has been disabled. Once in the operator seat, lower the safety bar. Have the assistant remove the lift arm support devices. The operator can then move the lift arm pedal or control lever to lower the lift arms to the ground.

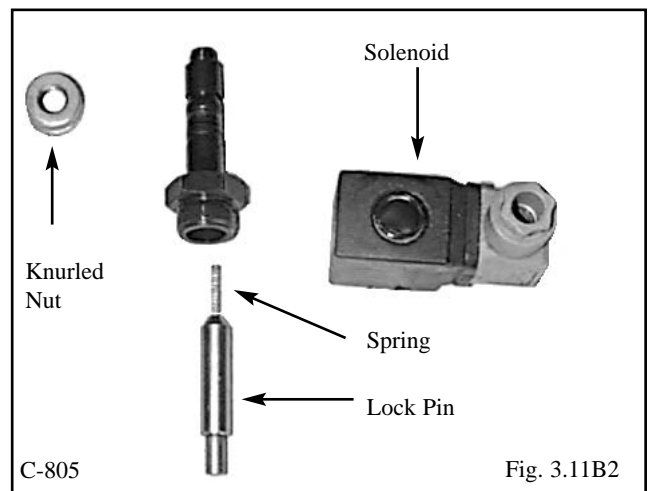
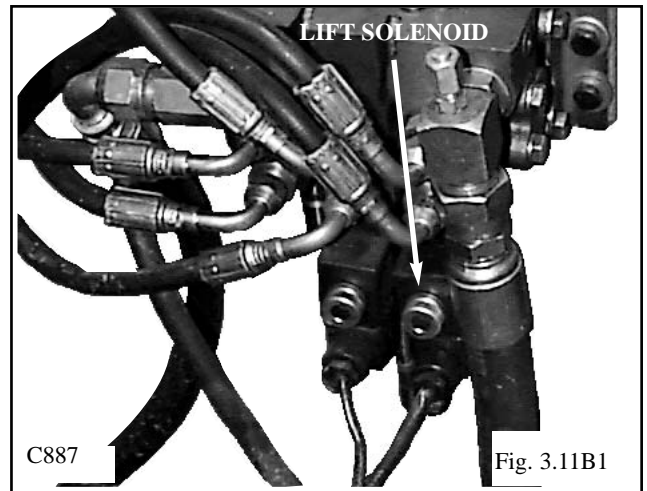

4...MAINTENANCE

4...MAINTENANCE

- 4. 1 Preventative Maintenance Service Schedule
- 4. 2 Daily Service Checks
 - 1. Radiator Service
 - 2. Hydraulic Oil Level
 - 3. Air Cleaner
 - 4. Tires and Wheel Nuts
 - 5. Safety Equipment
 - 6. Decals
 - 7. Lubrication
 - 8. Engine Oil Level
- 4. 3 50 Hour Service Check
 - 1. Engine
 - 2. Hydraulic / Hydrostatic
 - 3. Final Drive
 - 4. Controls & Safety Equipment
 - 5. Electrical
 - 6. Grease / Lubrication
 - 7. General
- 4. .4 Service Access
 - 1. Lift Arm Support
 - 2. Seat Removal
 - 3. Engine Compartment
- 4. 5 Final Drive Maintenance
 - 1. Oil Level Check
 - 2. Adding Oil
 - 3. Drive Chain, Axles and Socket Inspection
 - 4. Mounting Bolts
- 4. 6 Hydraulic/Hydrostatic System Maintenance
 - 1. Oil Level Check
 - 2. Adding Oil
 - 3. Main Hydraulic Filter Replacement
 - 4. Draining System Fluid
 - 5. Brake Service Override
- 4. 7 Engine Maintenance
 - 1. Engine Specifications
 - 2. Oil Level Check
 - 3. Engine Oil and Filter Replacement
 - 4. Cooling System Fluid
 - 5. Fan Belt Tension
 - 6. Fuel Filter Replacement
 - 7. Adding Fuel
- 4. 8 Air Cleaner Maintenance
 - 1. Daily Maintenance
 - 2. Servicing Cleaner Element
- 4. 9 Electrical System
 - 1. Circuit Diagram
 - 2. Battery Access
- 4. 10 Tire Maintenance
 - 1. Tire Inflation and Service
 - 2. Tire Rotation
- 4. 11 Trouble Shooting
 - 1. Hydrostatic Drive System
 - 2. Hydraulic System
 - 3. Final Drive System
 - 4. Control System
 - 5. Park Brake
 - 6. Electrical
 - 7. Engine
- 4. 12 Hydraulic/Hydrostatic Circuit
- 4. 13 Special Tools

4...MAINTENANCE

4.1 PREVENTIVE MAINTENANCE SERVICE SCHEDULE

| ITEM | SERVICE REQUIRED | 8 HOURS | 50 HOURS | 150 HOURS | 200 HOURS | 400 HOURS | 1000 HOURS |
|------------------------------------|---|---------|----------|-----------|-----------|-----------|------------|
| Engine Oil | Check level and add if necessary. Use 10W30 API Classification SE/CD oil. | | | | | | |
| Radiator | Check level and add if necessary. Fill with 50% mixture of ethylene glycol and water. Check cooling fins for dirt. If necessary blow out with compressed air. Check rubber seal around radiator baffle. | | | | | | |
| Hydraulic Oil | Check level and add if necessary. Use 10W30or 20W50 API Classification SE/CD oil. | | | | | | |
| Air Cleaner | Empty dust cap. Check condition indicator and service or replace element as required. | | | | | | |
| Tires and Wheel Nuts | Check for low pressure or tire damage. Inflate standard tires 30 - 35 PSI (345 KPa), flotation tires 30 - 35 PSI (207 - 241 KPa). Check wheel nut torque 100 - 110 ft. lbs. (136-149 N m) | | | | | | |
| Safety Equipment | Check all safety equipment for proper operation and condition. Seat belt, lift arm supports, quick - tach locks, parking brake, foot pedal locks, safety treads . Repair or replace if necessary. | | | | | | |
| Decals | Check for damaged safety or instruction decals (see section 5.4). If necessary replace. | | | | | | |
| Hydraulic Oil Filter | Check Filter Service Indicator | | | | | | |
| 50 Hour Service | Perform complete 50 hour service (see 4. 3). | | | | | | |
| Lubrication | Grease all hinge pin fittings until excess shows. | | | | | | |
| Engine Oil | Replace engine oil. Use 10W30 API Classification SE / CD oil. Initial change only. | | | | | | |
| Engine Oil Filter | Change engine oil filter element. Initial change only. | | | | | | |
| Muffler | Check the muffler for carbon buildup and plugging. If necessary clean. Check every 100 hours. | | | | | | |
| Safety System Linkages and Springs | Check and if necessary adjust. Lubricate foot pedal lock springs, shaft and linkage with a silicone based lubricant. | | | | | | |
| Hydraulic Oil Filter | Change hydraulic oil filter element. Initial change only. | | | | | | |
| 50 Hour Service | Perform complete 50 hour service (see 4. 3). | | | | | | |
| Final Drive | Check chain and sprocket condition. Check every 150 hours. | | | | | | |
| Engine Oil | Replace engine oil (initial change already made). Use 10W30 API Classification SE/CD oil. See 4 . 7 - 3. Replace every 200 hours. | | | | | | |
| Engine Oil Filter | Replace engine oil filter. See 4. 7 - 3. Replace every 200 hours | | | | | | |
| Hydraulic Oil Filter | Replace engine oil filter every 150 hrs or when the Service Indicator shows red. | | | | | | |
| | | | | | | | |

4...MAINTENANCE

| ITEM | SERVICE REQUIRED | 8 HOURS | 50 HOURS | 150 HOURS | 200 HOURS | 400 HOURS | 1000 HOURS |
|--|--|---------|----------|-----------|-----------|-----------|------------|
| Preventative Maintenance Service Check | It is recommended as a preventative maintenance procedure that the 50 hour service be repeated every 150 hours. (See section 4. 3) | | | | | | |
| Final Drive | Check Chain and Sprocket Condition. | | | | | | |
| Engine Fuel Filter | Replace engine fuel filter. See 4. 7 - 3. | | | | | | |
| Hydraulic Oil | Change hydraulic oil. Replace with 10W30 A.P.I. Classification SE/CD oil or 20W50 A.P.I. Classification SE/CD oil. | | | | | | |
| Final Drive | Change final drive lubricating oil. Use 10W30 A.P.I. Classification SE/CE oil. | | | | | | |
| Engine Cooling System | Drain, flush and refill. Use 50% mixture of ethylene glycol and water. | | | | | | |
| Hydraulic Reservoir Filters | Remove and replace the 100 micron suction element in the oil reservoir. (See 4. 6 - 3) | | | | | | |

NOTE: For complete engine service details refer to the engine manufacturers service manual. Specify Kubota Part # V1305B for this manual.

| | |
|--|---|
|  WARNING | <p>To avoid personal injury service repairs must be performed by an authorized Hyundai dealer.</p> |
|--|---|

4...MAINTENANCE

4.2 DAILY SERVICE CHECK

1. Radiator Service

With the engine cool remove the radiator cap and check the coolant level. If adding coolant is required fill with a 50% mixture of ethylene glycol and water for cold weather protection.

The radiator cooling fins must be kept free of debris otherwise overheating of the engine will occur. Inspect the radiator cooling fins for damage or buildup of debris. Repair any damage and if necessary flush the radiator with compressed air to remove debris.

2. Hydraulic Oil Level

Check the oil level with the machine on a level surface with the lift arms down and the bucket flat on the ground. Open the rear door and check the oil level sight glass (Fig. 4. 2A). If oil is apparent the oil level is satisfactory.

If necessary to add oil, remove the reservoir cap located at the top of the oil reservoir and add oil until oil appears in the oil level sight glass.

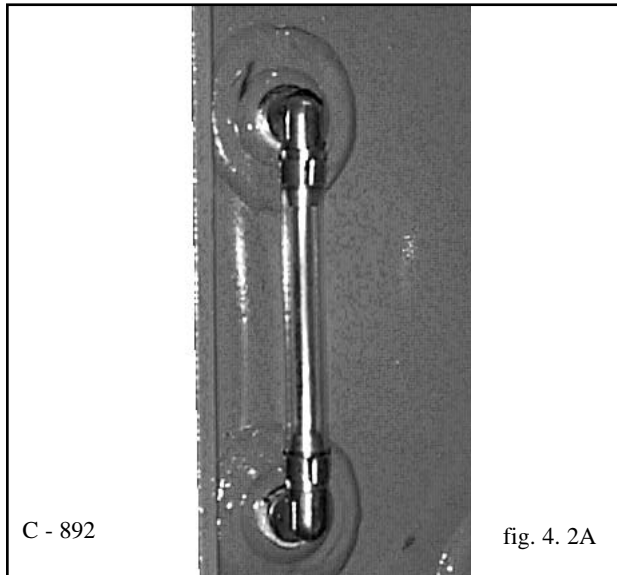

Use a good quality 10W30 or 20W50 oil which meets the API classification SE/CD only.

3. Air Cleaner

The T103S is equipped with an air pre-cleaner restriction visual indicator. If indicator changes from green to red, shut off the engine and determine cause. Possibly a plugged air filter. (Fig. 4.2B)

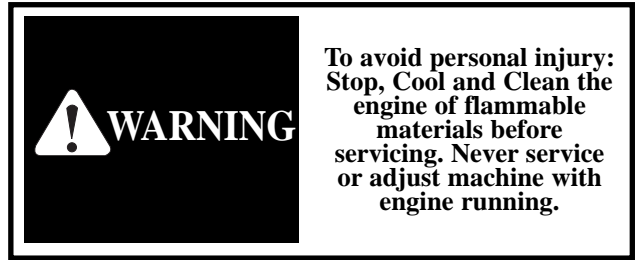

4 Tires and Wheel Nuts

Inspect tires for wear or damage. Check and inflate tires to correct pressure:

| | |
|--------------------|-----------------------------|
| 27.00 X 8.50 X 15 | 30 - 35 PSI (207 - 241 kPa) |
| 27.00 X 10.50 X 15 | 30 - 35 PSI (207 - 241 kPa) |

To prevent shearing of the wheel studs and rim damage check wheel nuts for proper torque 100 -110 lbs. ft.(136 - 149 N m) daily (Fig. 4. 2C). After changing a rim, Check wheel nuts hourly, until the reading stabilizes.

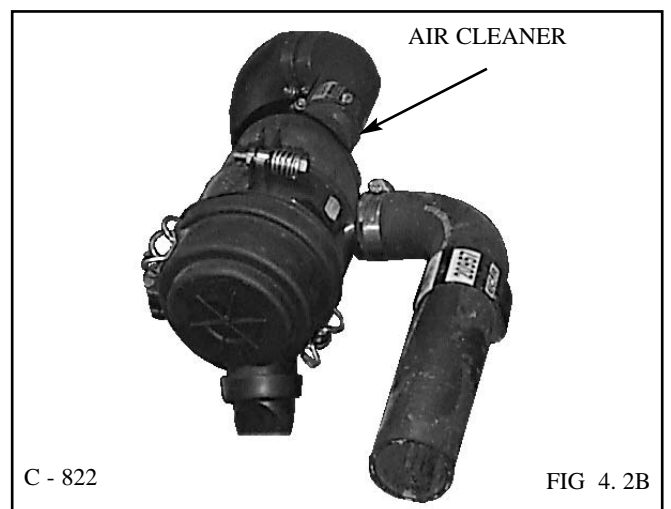
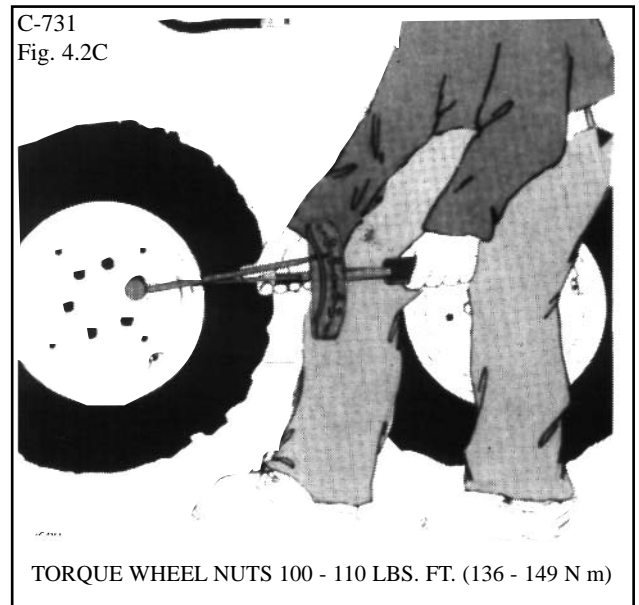

4...MAINTENANCE

5. Safety Equipment

Do not operate the loader unless equipment shields, seat belt, seat bar, hydraulic controls, parking brake, operator guard and lift arm supports are working properly as well as all safety and instruction decals are in place.

6. Decals

Check the condition of all safety and instruction decals. Replace any damaged or missing decals. Refer to section 5. 4 for decal description and locations.

7. Lubrication

There are sixteen grease fittings located in the loader that require lubrication every eight hours. Lubricate with a good quality multi-purpose lithium based grease. Apply grease until excess shows. Refer to the service schedule for complete service details.(See Fig. 4. 4G). The sixteen lubrication points are:

- Rear Lift Arm Pivots (2)
- Lift Arm Cylinder Bushings (4)
- Bucket Cylinder Bushings (4)
- Lift Arm Supports (2)
- Quick Tach Pivot and Lock Pins (4)

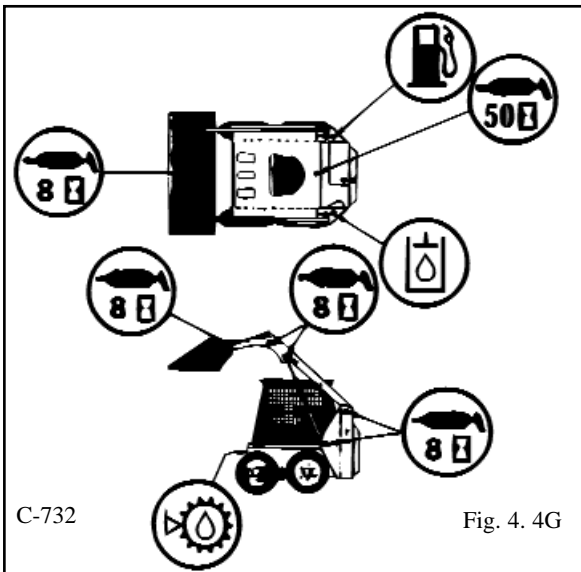

8. Engine Oil Level

To check the oil level, stop the engine with the loader on level ground, open the rear door and remove the dipstick (Fig. 4. 4I1).

Keep the oil level between the full and low mark on the dipstick (Fig. 4. 4I2). Do not fill above the full mark – use 10W30 or 20W50 API Classification SE/CD oil.

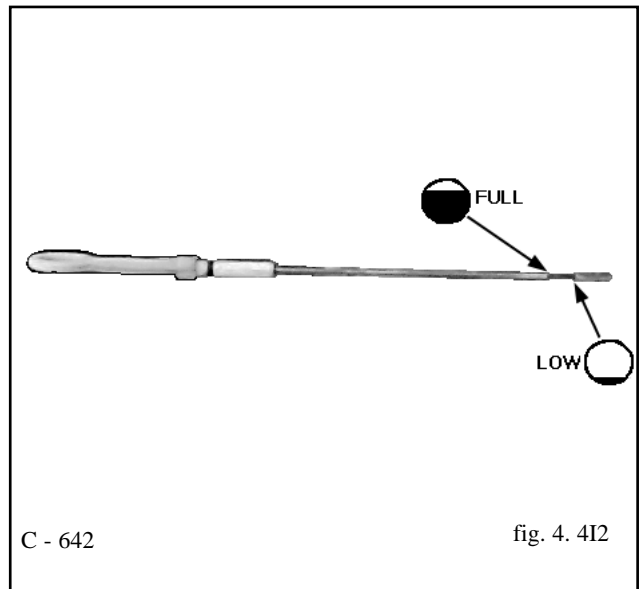
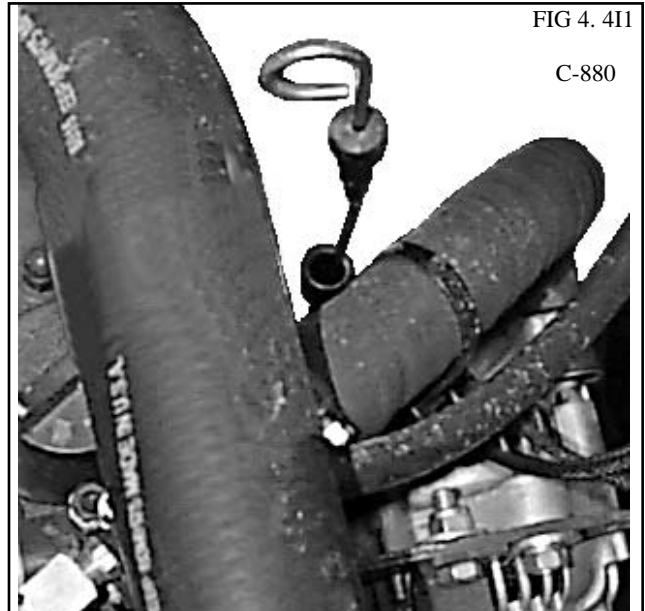

4...MAINTENANCE

4.3 50 HOUR SERVICE CHECK

The following service check is to be performed by your dealer after the first 50 hours of operation.

1 Engine

1.1 Oil Filter:

Change the engine oil filter. Use only original replacement parts. Refer to section 4.7 - 3 for installation details. Change the oil filter every 150 hours.

1.2 Engine Oil:

Change the engine oil. Use only 10W30 API classification SE/CD oil. Refer to section 4.7 - 3 for procedure. Change engine oil every 150 hours.

1.3 Coolant Level:

Check that the coolant is to the proper level. The cooling system is filled with a 50% mixture of ethylene glycol and water. (see Section 4.7 - 4)

1.4 Radiator for Leakage and Dirt:

If necessary flush the radiator with compressed air. A dirt buildup on the radiator cooling fins can cause both engine and hydraulic system overheating. Check rubber gasket on radiator baffle.

1.5 Fan Belt Tension and Condition:

Check fan belt for cuts and wear, if necessary replace. Check tension and adjust as shown Section 4.7 - 5.

1.6 Fuel System for Leaks:

Make a visual inspection of fuel system for leaks and potential hazards such as fuel line(s) touching exhaust manifold, flywheel, etc. Replace fuel filter every 400 hours.

1.7 Air Intake and Cleaner System:

Visually inspect the air cleaner system and be sure all hose clamps are secure. Check that the filter indicator is not indicating that filter service is required.

1.8 Exhaust System:

Visually inspect the exhaust system and ensure all clamps are secure and the manifold bolts/nuts are tight.

1.9 Engine Speed:

Check and if necessary adjust engine R.P.M. See specifications.

1.10 Muffler:

Check muffler for carbon and soot buildup and plugging. If necessary clean.

**WARNING**

To avoid personal injury, lower the lift arms, shut off the engine, raise the seat bar and cycle the hydraulics to ensure they are locked. Then, unlatch the seat belt and exit the loader. Do not enter or exit with the engine running unless as specified in this manual or under specific service and backhoe operating procedures.

2 Hydraulic/Hydrostatic

2.1 Hydraulic Oil Filter:

Change the hydraulic filter only when the filter indicator changes from green to red or every 150 hrs. Lubricate the filter cartridge seal with system fluid.

2.2 Hydraulic Oil Level:

If oil is visible in the oil level sight glass the level satisfactory. If additional oil is required use only 10W30 or 20W50 API classification SE/CD oil. Fill to the top or maximum check point.

2.3 Hoses and Pipes:

Make a visual inspection of all hydraulic lines and fittings for leaks. Check that steel lines do not touch one another.

2.4 Cylinders:

Inspect cylinders for leaks. Extend cylinders and check for rod damage.

2.5 Hydraulic Functions:

Check that the following operate properly: control valve float position, auxiliary hydraulic detent, hydraulic cylinders.

2.6 Pumps & Motors, Leakage:

Inspect pumps and motors for leaks.

**WARNING**

To avoid personal injury: Never repair or tighten hydraulic hoses or fittings with the engine running or the system under pressure.

IMPORTANT

Keep the rear door closed except for servicing. Make sure the door is closed and latched before operating the loader.

4...MAINTENANCE

3 Final Drive

3.1 Oil Level:

Check lubricating oil level. If necessary add 10W30 API classification SE/CD oil.

3.2 Drive Chain Tension and Condition:

Check drive chains for any sign of wear or damage. Check lubrication oil in housing for signs of contamination.

3.3 Hydrostatic Motor Mounting Bolts: Check torque 85 - 90 ft. lbs. (115 - 122 N m)

3.4 Axle Bearing End Play:

Axle bearings are preloaded and must have no end play. Inspect and adjust if necessary.

4 Controls and Safety Equipment

4.1 Control Levers, Operation and Linkage:

Check that the steering levers operate freely without binding, they return to neutral when released and the machine travels in a straight line with both levers in forward position. Lubricate linkage with a silicone based lubricant.

4.2 Foot Pedals, Operation and Linkage:

Check that the foot pedals operate freely without binding. Before leaving the operator seat, ensure the pedals are locked, raise the safety bar and unbuckle the seat belt, to test the seat switch, grasp the seat bar and raise your weight off the seat and check pedals at the same time to ensure they are locked. Lubricate linkage with a silicone based lubricant.

4.3 Engine Throttle Control:

Check that the throttle control operates freely without binding or slackening off due to vibration.

4.4 Parking Brake:

Check that the parking brake engages and completely disengages. The park brake automatically engages with seat bar up.

4.5 Lift Arm Supports:

Check that the lift arm supports operate without binding.

NOTE:Ensure the lift arm supports are fully retracted before raising or lowering the lift arms.

4.6 Quick - Tach, Operation & Linkage:

Ensure the quick - tach linkage operates smoothly without binding engage completely.

4.7 Seat Belt:

Check seat belt condition. If necessary replace.

For your safety, the loader is equipped with electrically activated safety devices through the seat and seat belt. Consult your repair manual for repairs.

5 Electrical

5.1 Battery: Maintenance Free.

5.2 Battery Terminals:

Check battery terminals for corrosion. If necessary, clean.

5.3 Operation of Starter:

Engage and disengage the starter several times to ensure it's working properly. To prevent starter damage do not engage for more than 15 seconds. Allow 1 minute between starting attempts for cooling the starter.

5.4 Operation of Electrical Equipment:

Make a complete check of all electrical equipment, gauges, warning devices, pre - heat indicator, work lights, seat belt switch and seat bar and all optional equipment to ensure they are operating correctly.

6 Grease/Lubrication

Lubricate the following points with a good quality grease. Numbers marked () indicate the number of fittings at each location.

Rear Lift Arm Pivots (2)

Lift Arm Cylinder Bushings (4)

Bucket Cylinder Bushings (4)

Lift Arm Supports (2)

Quick - Tach Pivot and Lock Pins (4)

7 General

7.1 Tire Pressure:

Check tire pressure and if necessary inflate to the following pressures:

8.50 x 15.0 30 - 35 PSI (207 - 241 kPa)

10.50 x 15.0 30 - 35 PSI (207 - 241 kPa)

7.2 Wheel Nut Torque:

Check and torque wheel nuts to 100 - 110 ft. lbs. (136 - 149 N m).

4...MAINTENANCE

7.3 Condition of Cab:

Inspect both the seat and seat belt. Ensure all safety and instruction decals are in place. Inspect sound insulation, side windows and door operation for machines equipped with cab enclosure kits. Inspect for structural damage and alterations to R.O.P.S

7.4 Condition of Shields and Safety Equipment:

Inspect and ensure all shields are in place and securely fastened. Inspect and ensure all safety equipment is working properly. Ensure owners and operators manual, safety manual and all safety and instruction decals are in place. if necessary replace. If the safety controls are malfunctioning or require adjustment consult your **Hyundai** Equipment Dealer for service.

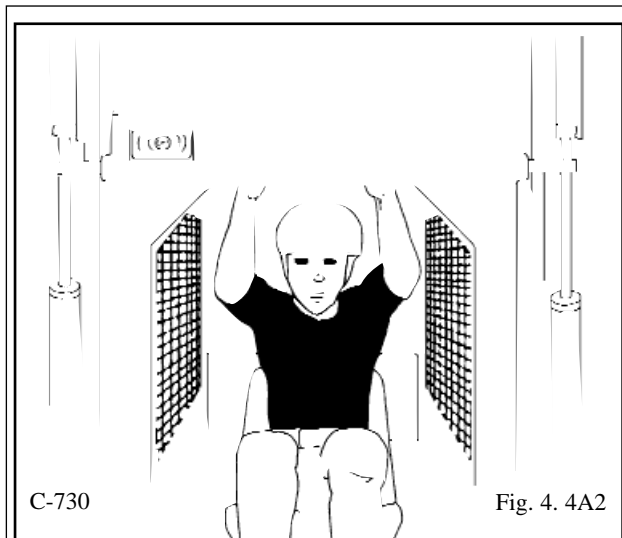
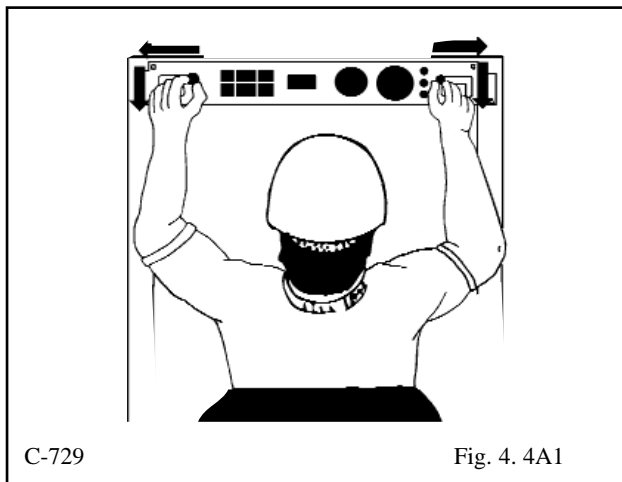

7.5 General Condition:

Make a general inspection of the machine looking for loose or missing parts, oil leaks, etc.



4.4 SERVICE ACCESS

1. Lift Arm Support

For safety while performing regular service or maintenance work, the loader is equipped with lift arm support pins. The lift arm support pins, when extended, prevent the lift arms from dropping if hydraulic pressure is relieved or the hydraulic controls are accidentally cycled.

To operate the lift arm support, first remove any bucket or attachment from the quick - tach; raise the lift arms to full height. Raise the lift arm support handle (fig. 4. 4A1) up and push out toward lift arms to extend the lift arm locking pins (fig. 4. 4A2) Slowly lower the lift arms down on to the pins.

2. Seat Removal

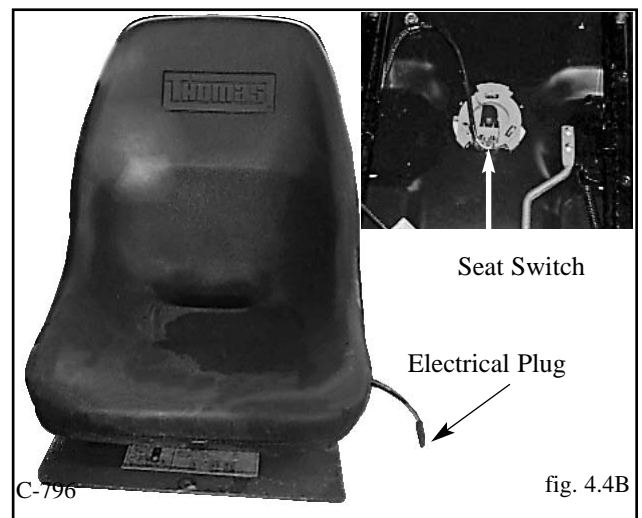

The seat and seat plate can be removed to provide access to the controls, hydraulic and hydrostatic components. To remove the seat assembly, remove the fasteners located at the front of the seat. **Disconnect the electrical plug!!** Lift the seat assembly out of the machine. When installing the seat, be sure the seat plate locks are in place at the rear (Fig. 4. 4B).

4...MAINTENANCE

3. Engine Compartment

The engine compartment is completely enclosed for component protection and lockable to discourage vandalism. For servicing, the rear door swings open and the engine cover hinges up. To open; pull door latch upward, grasp the door handle and swing the door open. (See Fig. 4. 4C1). Lower the engine cover before closing the rear door. (See Fig. 4. 4C2)

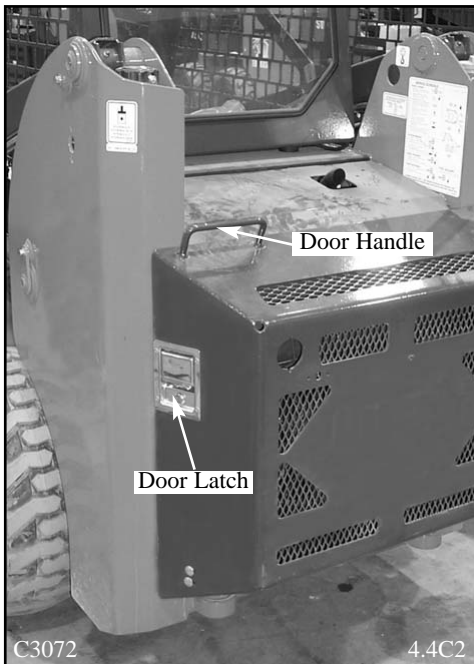

IMPORTANT

Keep the rear door closed except for servicing. Make sure the door is closed and latched before operating the loader.

4.5 FINAL DRIVE MAINTENANCE

1. Oil Level Check

The loader has two independent final drive housings. Check the lubricating oil level with the loader on a level surface. Remove the check plug (Fig. 4. 5A) located on the front of the frame to determine the oil level. The oil level should be checked after 50 operating hours and every 150 hours thereafter. It is recommended the oil be changed after 1000 operating hours or if it shows signs of contamination.

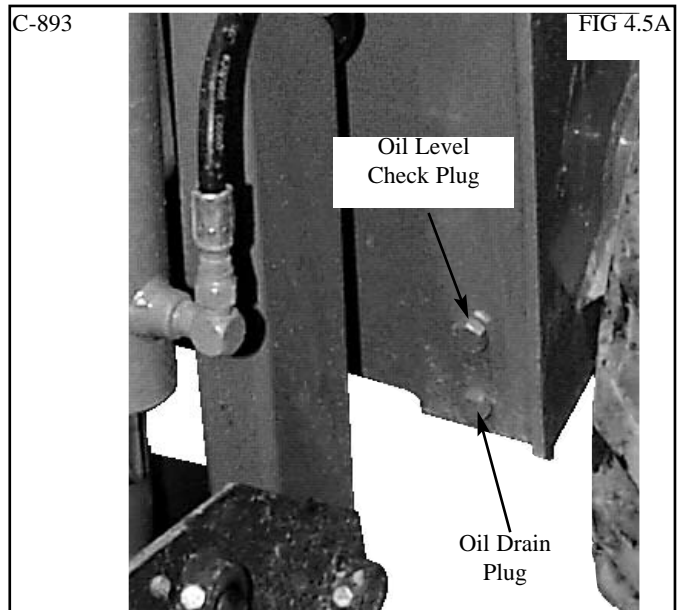

4...MAINTENANCE

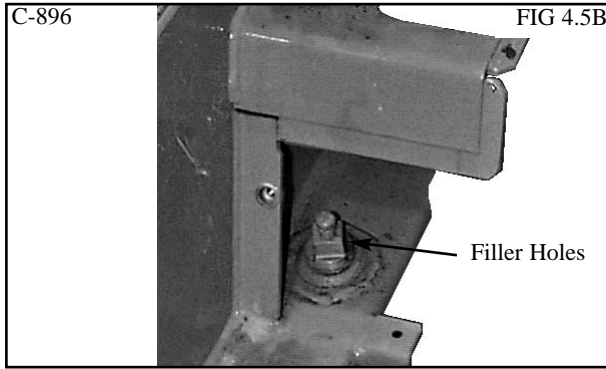

2. Adding Oil

Add oil with the loader on level ground. Remove the oil level check plug (Fig. 4. 5A) on the final drive housing. remove the filler cap (Fig. 4. 5B). Fill with 10W30 API Classification SE/CD engine oil check plug level, total capacity is 3.5 gal. (13 l).

3. Drive Chain, Axle and Sprocket Inspection

The condition of the drive chains should be checked after the first 50 hours of operation and every 150 hours thereafter.

To inspect, block the loader securely with all four wheels clear off the ground. Remove both the front and rear wheels. On reassembly torque the wheel nuts to 100-110 ft. lbs. (136-149 N m). Remove the inspection cover on the side of the chain drive housing.

Inspect the chain for any sign of wear, damage or excessive looseness. Inspect the sprockets for any sign of damage or excessive wear. Inspect the lubricating oil for signs of contamination. Check the axle bearings for loss of bearing preload. If necessary adjust the bearings for zero end play.

4.6 HYDRAULIC/ HYDROSTATIC SYSTEM MAINTENANCE

1. Oil Level Check

Check the oil level of the hydraulic reservoir with the machine on a level surface with the lift arms down and the bucket flat on the ground. Open the rear door and check the oil level sight glass (Fig. 4.6A). If oil is apparent the level is satisfactory.

2. Adding Oil

To add oil, remove the oil filler cap located at the top of the oil reservoir (Fig. 4. 6B). Check the filter screen in the filler neck for signs of damage. Add 10W30 or 20W50API Classification SE/ CD engine oil until oil is visible in the oil level sight glass (Fig. 4.6A).

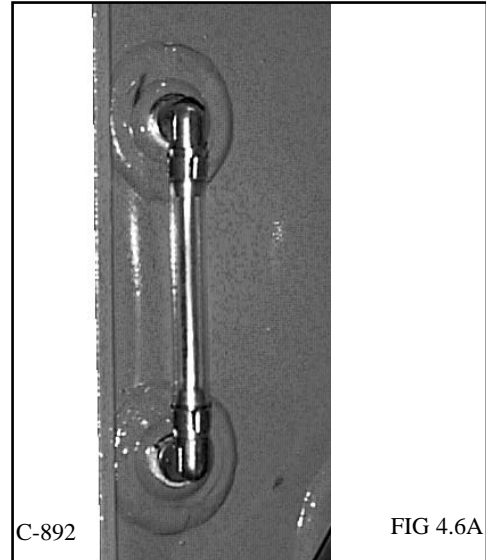

WARNING

WARNING: Escaping hydraulic fluid under pressure can penetrate the skin causing serious injury.

- **DO NOT** use your hand to check for leaks. Use a piece of cardboard or paper to search for leaks.
- Stop engine and relieve pressure before connecting or disconnecting lines.
- Tighten all connections before starting engine or pressurizing lines.

If any fluid is injected into the skin obtain medical attention immediately.

WARNING

To avoid personal injury, lower the lift arms, shut off the engine, raise the seat bar and cycle the hydraulics to ensure they are locked. Then, unlatch the seat belt and exit the loader. Do not enter or exit with the engine running unless as specified in this manual or under specific service and backhoe operating procedures.

4...MAINTENANCE

3. Main Hydraulic Filter Replacement

The hydraulic oil filter must be changed after the first 50 hours operation. This filter has an indicator which indicates a blocked filter. Change the filter when it indicates a blocked condition or every 150 hours whichever is first. To change the filter; shut off the engine, lower the lift arms, ground any attachment and set the parking brake. Open the rear door and using an oil filter wrench remove the filter element (Fig. 4.6C). Lubricate the new filter element with system fluid and reinstall.



4. Draining System Fluid:

Change the hydraulic oil:

1. after 1000 operating hours,
2. if the oil has become contaminated
3. after any major hydrostatic repair.

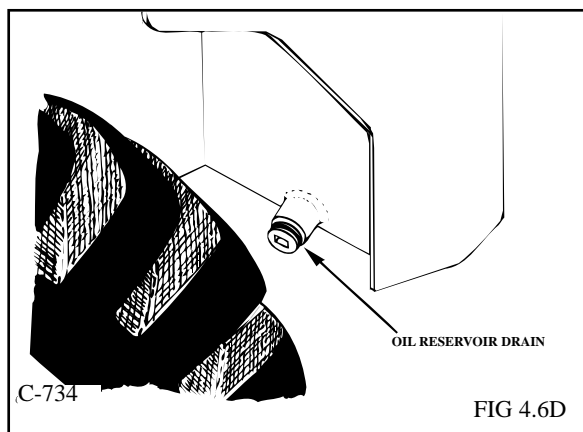

To drain the oil: remove the drain plug located at the bottom of the reservoir (Fig. 4.6D). Refill the hydraulic oil reservoir with 10W30 or 20W50 API Classification SE/CD engine oil.

5. Brake Service Override

A Service Override has been incorporated for use by **Hyundai** Dealers. The normal position of the plunger is down and turned into the locked position.

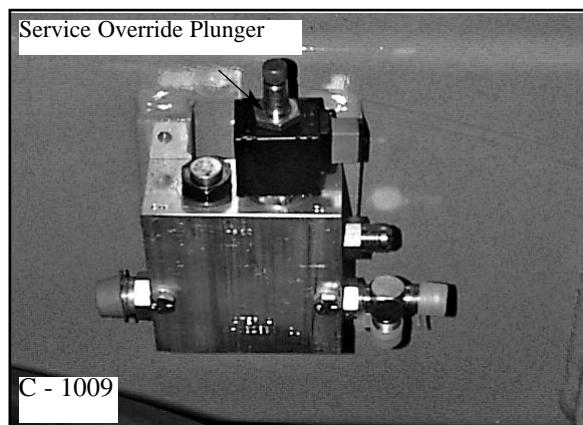

WARNING

To avoid personal injury: Stop, Cool and Clean the engine of flammable materials before servicing. Never service or adjust machine with engine running.

4.7 ENGINE MAINTENANCE

1. Engine Specifications

| | |
|-------------------------------------|-------------------------|
| Make | Kubota |
| Model | V1305B |
| No. of Cyls. | 4 |
| H.P. (kW). | 33.5 (25) |
| ISO Net | 22.5 Kw @ 3000 RPM |
| Max. Torque | 43.4 ft lbs. |
| | (6 kg/m) @ 3000 RPM |
| Displacement | 81.5 cu. in.(1335 c.c.) |
| Max. High Idle | 3000 |
| Engine Oil Capacity | 9 qts. (8.5 L) |
| Oil Pressure | 28 - 64 PSI @ 3000 |
| | (193 - 441 kPa) |
| Injector Working Pressure | 1991 - 2133 PSI |
| | (13.7 - 14.7 MPa) |
| Cooling System Capacity | 3.2 gal. (12 l) |
| Radiator Pressure Cap Setting | 7 PSI (48 kPa) |
| Thermostat Rating | 180°F (82°C) |
| | Full open |
| Alternator | 60 A |

4...MAINTENANCE

2. Oil Level Check

To check the oil level, stop the engine with the loader on level ground, open the rear door and remove the dipstick (Fig. 4. 7B1).



Keep the oil level between the full and low mark on the dipstick (Fig. 4. 7B2). Do not fill above the full mark – use 10W30 API classification SE/CD oil.

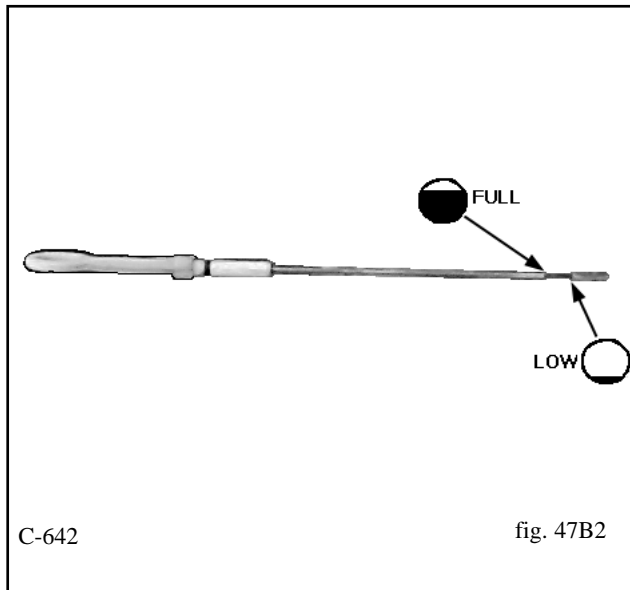

3. Engine Oil and Filter Replacement

Operate the engine until warm, approximately 5 minutes. Stop the engine.

Remove the cap on the oil drain hose located at the bottom of the oil pan. (Fig 4. 7C1).

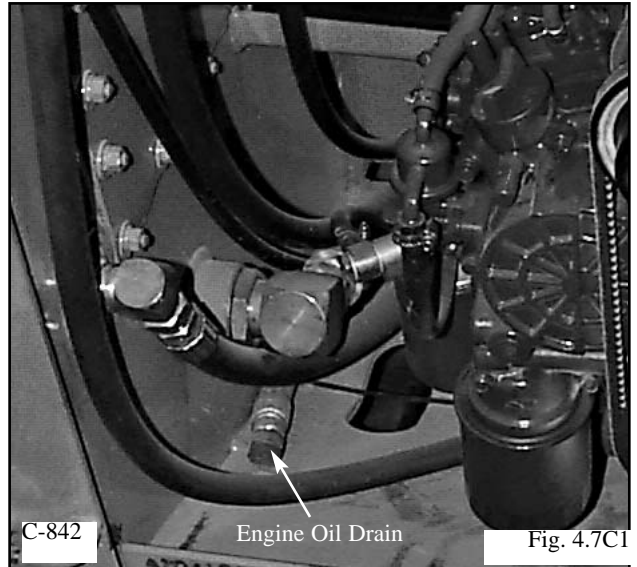

Remove the oil filter (Fig. 4. 7C2). Clean the filter housing surface. Put clean oil on the seal of the new filter and install the filter hand tight. Replace the oil drain plug. Remove the filler cap and add 10W30 API classification SE/CD engine oil. Start the engine and run for 5 minutes. Stop the engine and check for leaks at the filter. Recheck the oil level and add oil until the level is at the top mark on the dipstick.

Oil Check *Daily*

Oil Change 150 hrs.

Filter Change 150 hrs.

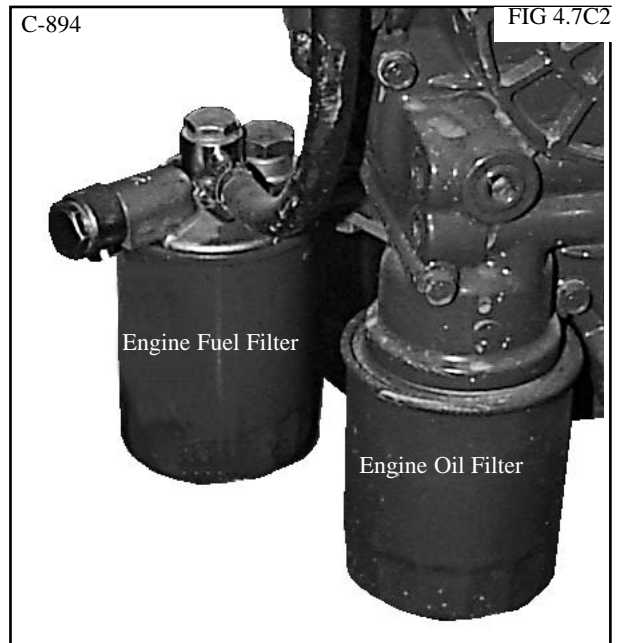

4...MAINTENANCE



4. Cooling System Fluid

The engine cooling system fluid is a 50 - 50 mixture of ethylene glycol and water for cold - weather protection.

To drain the cooling system; attach a hose to the drain valve located at the engine block (Fig. 4. 7D1). Remove the radiator cap. Turn the drain valve handle so that it's toward the valve outlet. To completely drain the radiator open the drain valve located at the bottom of the radiator (Fig. 4. 7D1).

To fill the cooling system; close the drain valve on the engine block (Fig. 4. 7D1) and refit the radiator drain plug. Fill the radiator with a 50 - 50 mixture of ethylene glycol and water. Refit the radiator cap.



5. Fan Belt Tension

Check the fan belt tension midway between the fan pulley and alternator pulley (Fig. 4. 7E1). Deflection should be between 1/4 to 3/8 in. (7 - 9 mm). Ensure the Fan Belt Guard is replaced after the tension check.(Fig 4. 7E2).

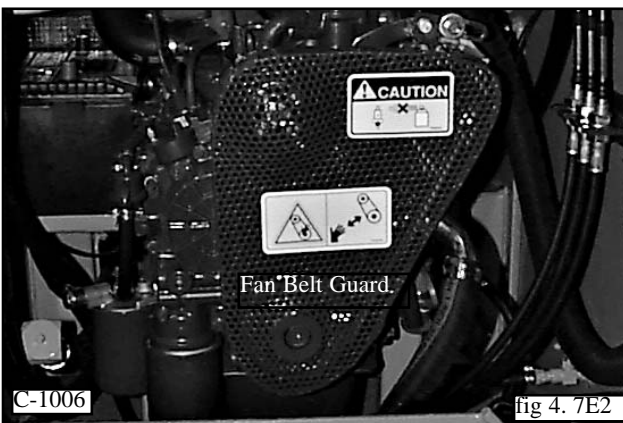

6. Fuel Filter Replacement

The fuel filter is located in the engine compartment on the left hand side (Fig. 4. 7F). The fuel filter should be removed every 100 hours and any water or dirt found in the element drained off. Change the filter every 400 hours. To replace the filter; close the fuel inlet line shut - off located on the side of the fuel tank (Fig. 4. 7F). Remove the filter element (Fig. 4. 7F). Lubricate the seal on the new filter and install the filter hand tight. Open the fuel inlet shut-off. It is not a requirement to bleed air from the fuel system. Follow Section 3. 1 for starting procedures.

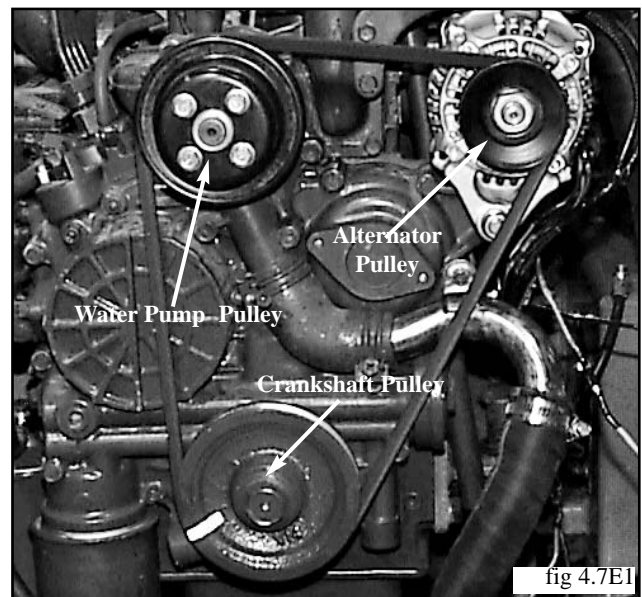
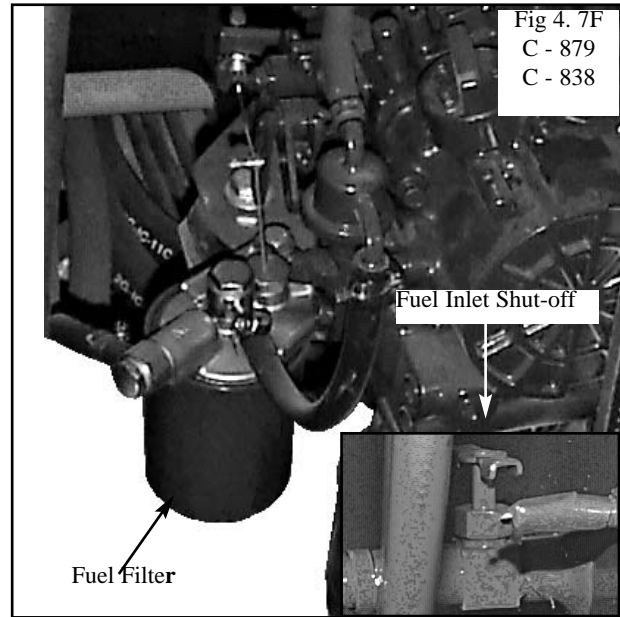

4...MAINTENANCE

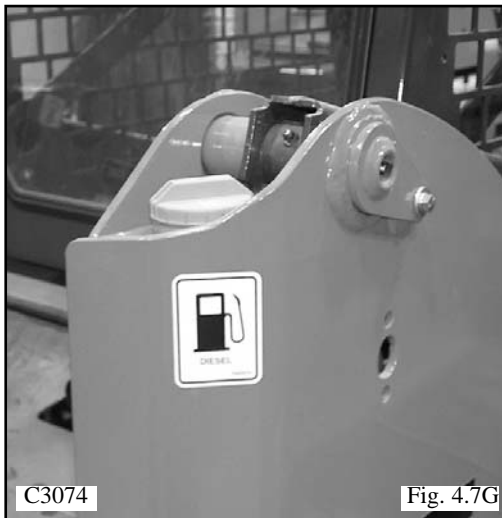

7. Adding Fuel

Use No. 2 diesel fuel only. Total tank capacity 14.6 gal. (55 L).

Before adding fuel to the loader the key switch must be off and the engine must be cool. Remove the fuel cap (Fig. 4. 7G). Use a clean approved safety container to add fuel. Add fuel only in an area that is well ventilated and away from open flames or sparks – NO SMOKING.

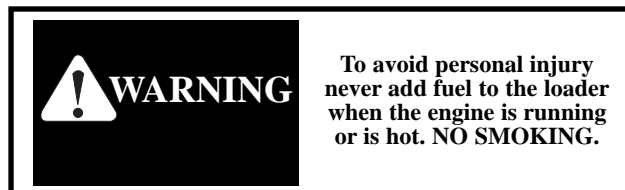

4.8 AIR CLEANER MAINTENANCE

1. Daily Maintenance

Inspect the air precleaner canister for holes or dents, or missing or mis-aligned gaskets. Check all hose clamps for tightness and inspect the hoses for damage. Check the vacuator for damage.

2. Servicing Cleaner Element

To replace the air filter element carry out the following:

1. Empty the dust cap as required. Dust should not be allowed to build up closer than 1 in. from the baffle.
2. Remove the primary element as gently as possible. Before installing the new element inspect the element and gasket for shipping or storage damage.
3. Always clean the inside of the housing and gasket seating surface making sure no dust is allowed into the intake duct.
4. Check for uneven dirt patterns on the old filter. Make sure the new gasket is seating evenly. Reinstall dust cap, making sure it seals 360 degrees around the cleaner body. Reset the restriction indicator.
5. Check all connections between the air cleaner and the engine to be certain they are tight and leak - free.

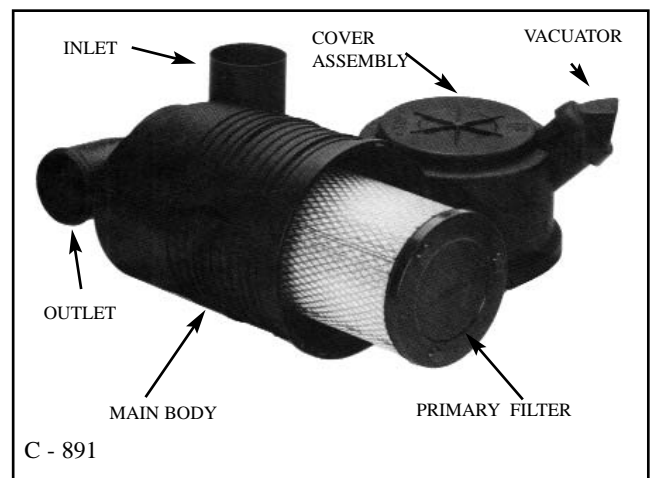

4...MAINTENANCE

4.9 ELECTRICAL SYSTEM Electrical Schematic HSL500T

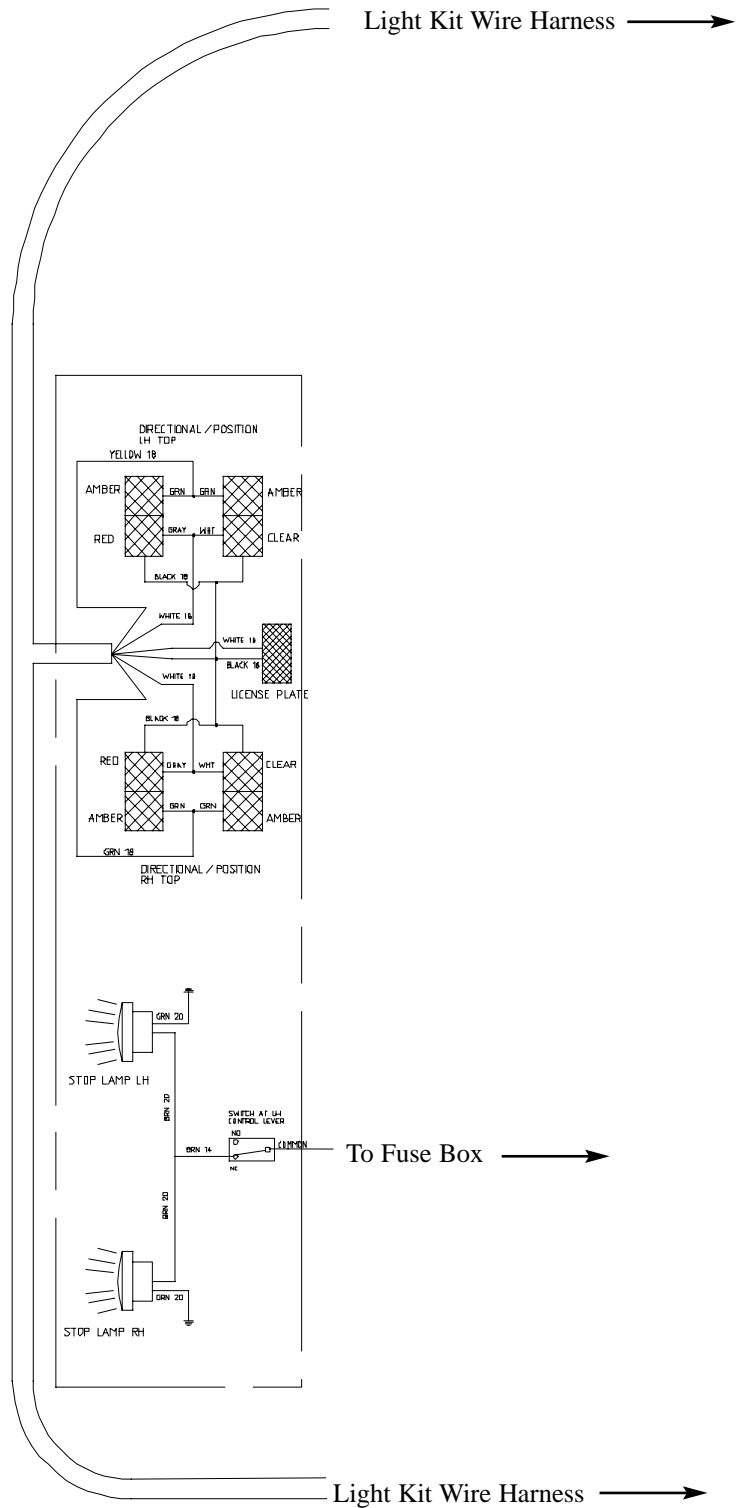

C3159

4...MAINTENANCE

4.9 ELECTRICAL SYSTEM

Electrical Schematic HSL500T

Light Kit Wire Harness

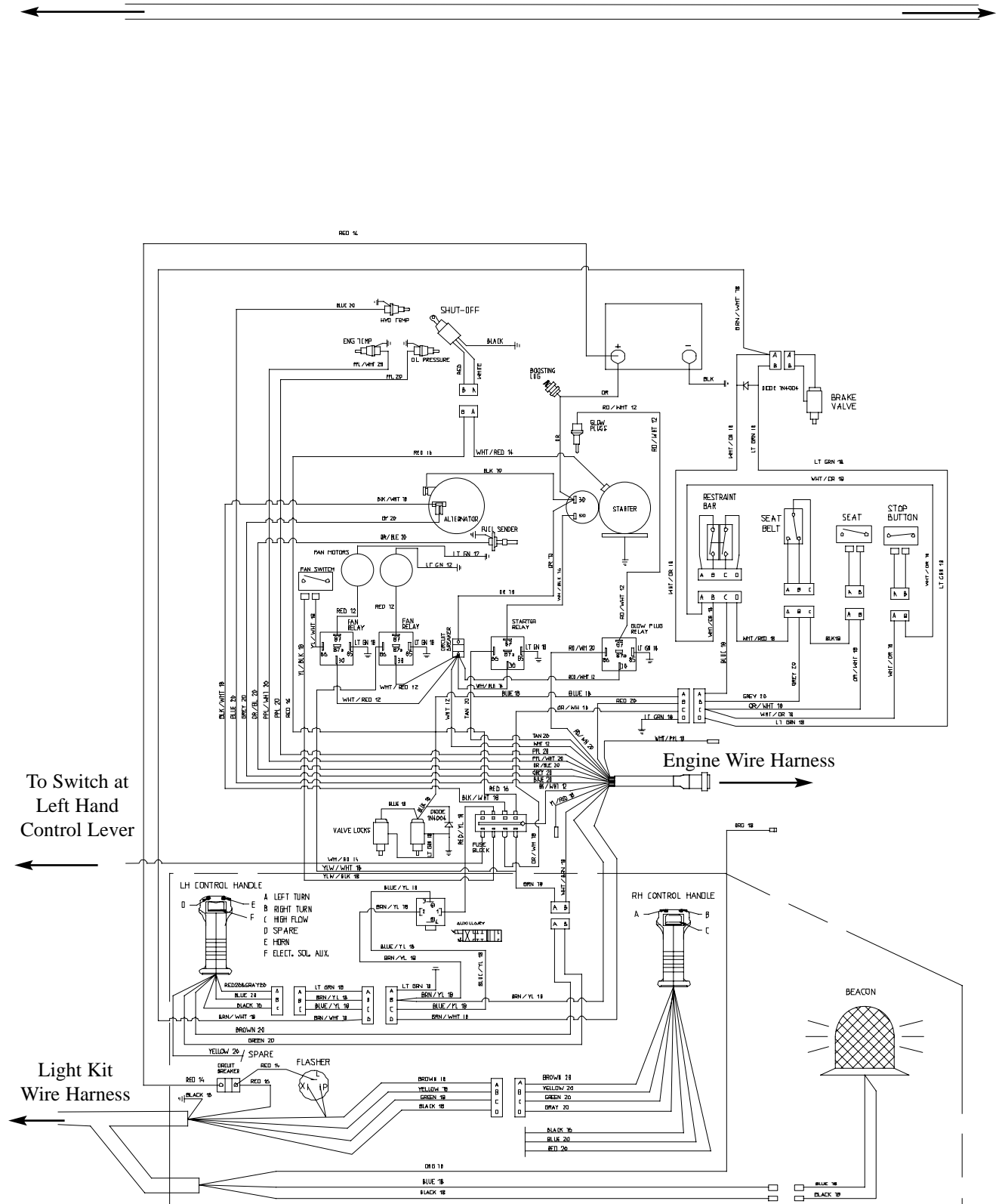

To Switch at
Left Hand
Control Lever

Light Kit
Wire Harness

Engine Wire Harness

4...MAINTENANCE

2. Battery Access

The battery is located behind the LH transmission, in the engine compartment (See Fig. 4. 9B1 & B2).

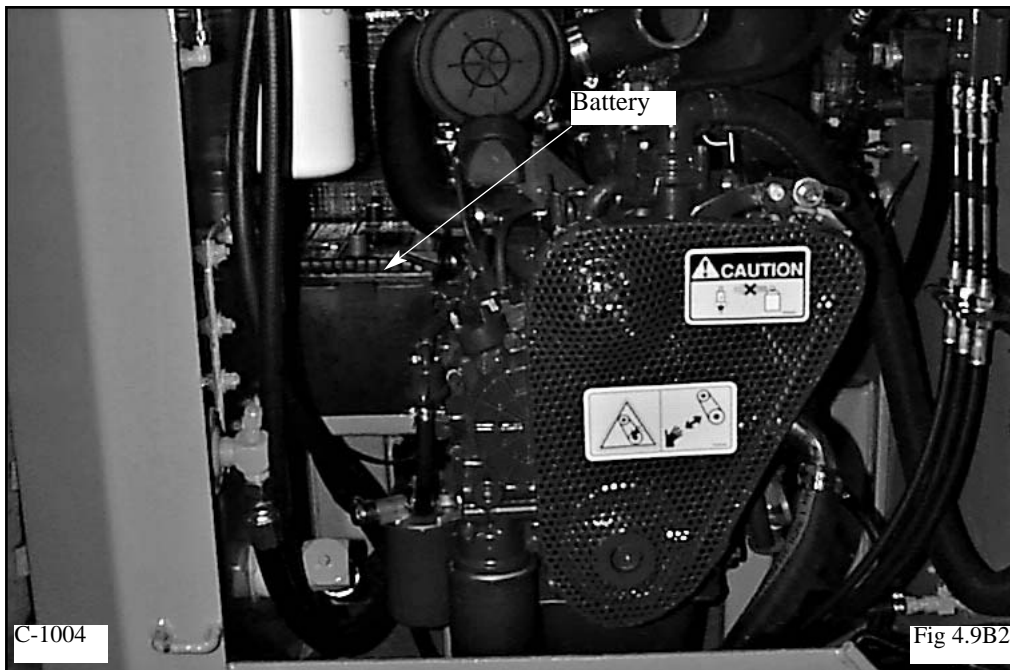
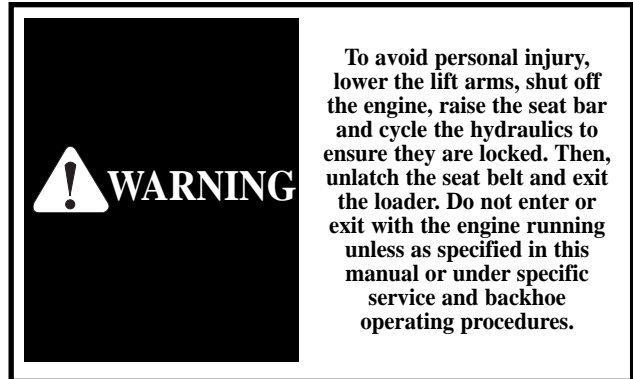
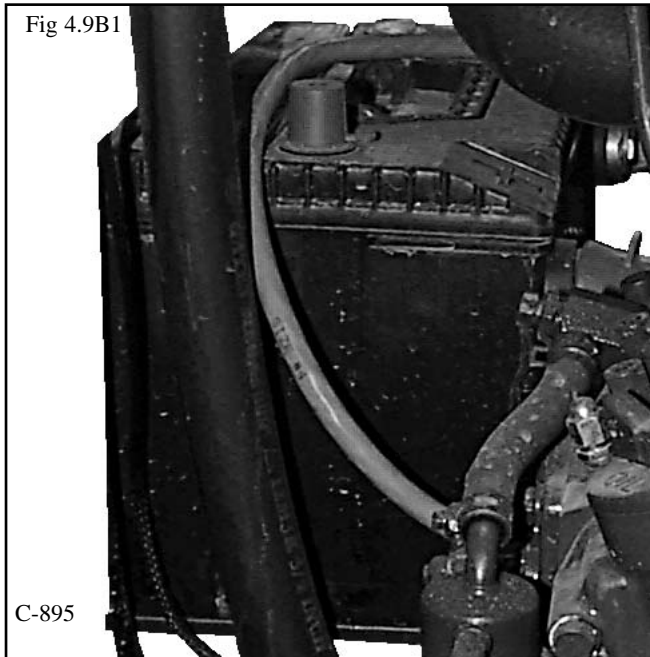

4...MAINTENANCE

4.10 TIRE MAINTENANCE

1. Tire Inflation and Service

1. 1 Upon receiving your loader, check the air pressure in the tires as indicated in the table.
1. 2 Check tire pressure every 50 hours or weekly.
1. 3 Tire inflation pressure affects the amount of weight which a tire may carry. Do not over or under inflate the tires.
1. 4 Do not inflate a tire above the manufacturer's maximum pressure shown on the tire or the maximum pressure shown in the table.
1. 5 Do not re - inflate a tire that has been run flat or seriously under - inflated until the tire has been inspected for damage by a qualified person.
1. 6 When checking tire pressure, inspect the tire for damaged side walls and tread cuts. Neglected damage will lead to early tire failure.
1. 7 Be sure the rim is clean and free of rust.
1. 8 Lubricate both tire beads and rim flanges with soap solution. Do not use oil or grease.
1. 9 Use a clip - on tire chuck with a remote hose and gauge which allows the operator to stand clear of the tire while inflating it.
1. 10 After seating the beads, adjust inflation pressure to recommended operating pressure.
1. 11 Do not inflate a tire unless the rim is mounted on the loader or is secured so that it will not move if the tire or rim should suddenly fail.
1. 12 Do not weld, braze or otherwise repair a rim. Do not use a damaged rim.
1. 13 Never attempt tire repairs on a public road or highway.
1. 14 Use jack stands or other suitable blocking to support the loader while repairing tires.
1. 15 Insure jack has adequate capacity to lift your loader.
1. 16 Insure jack is placed on a firm level surface.
1. 17 Do not put any part of your body under the loader or start the engine while the loader is on the jack.
1. 18 Torque lug nuts to specification after reinstalling wheel. Check lug nut torque hourly until torque stabilizes.



WARNING

To avoid personal injury: Inflating or servicing tires can be dangerous. Trained personnel should be called to service and/or mount tires when possible. In any event to avoid possible serious or fatal injury, follow the safety precautions below.



WARNING

NEVER INFLATE TIRES TO OVER 240 KPA (35 PSI) TO SEAT BEADS. If beads have not seated by the time pressure reaches 240 KPa (35 PSI), deflate the assembly, reposition the tire on the rim, relubricate both tire beads, rim flanges and re-inflate. INFLATION Beyond 240 KPa (35 PSI) with unseated beads may break the bead or rim with EXPLOSIVE force, sufficient to cause serious injury.

| Tire | Inflation Pressure |
|--------------|-----------------------------|
| 8.50 x 15.0 | 30 - 35 PSI (207 - 241 kPa) |
| 10.50 x 15.0 | 30 - 35 PSI (207 - 241 kPa) |

2. Tire Rotation

The front and rear tires will wear at different rates. For even wear move the front tires to the rear and the rear tires to the front when wear is first noticed.

If two tires become worn more than the other two put the two worn tires on the same side.

When new tires are installed, always keep tires the same size on the same side of the loader. Two different size tires on the same side of the loader will cause drive chain wear, tire wear and a loss of power.

4...MAINTENANCE

4. 11 TROUBLESHOOTING

1. Hydrostatic Drive

| Power | Cause | Remedy |
|--|---|--|
| No power on one side (both directions) | Reservoir low on oil | Replenish with 10W30 API SE/CD oil. Check for hose or fitting leak. |
| | Disconnected control linkage | Reconnect and adjust linkage. |
| | Groove pin sheared on pump pintle lever | Replace. Check pintle lever for loose bolt or excessive play. |
| | High pressure line failure | Replace line. Ensure new line fits without being forced. If necessary stress relieve. |
| | Drive chain failure Adjust tightener tension. | Replace chain or connection link. |
| | Motor shaft or key failure Check mounting bolts. | Inspect and repair defective parts. motor |
| | Excessive internal leakage in and/or motor pump | Inspect and repair defective unit. Flush all lines and tank. Replace filter. Check on type of fluid used and engine RPM. |
| No power on one side (one direction only) | Defective relief valve | Replace defective valve. |
| | Damaged ball check | Disassemble and repair. |
| No power on both sides also loss of hyd. power | Reservoir low on oil | Replace with 10W30 or 20W50 API SE/CD oil. check for hose or fitting leak |
| | Pump coupling failure | if damaged, consult dealer or Hyundai Service Dept. |
| | Check system pressure | If low, consult dealer or Hyundai Service Dept. |
| Gradual loss of power as machine warms up | Excessive internal leakage in pump and/or motor | Consult dealer or Hyundai Service Dept. |

| Power | Cause | Remedy |
|--|--|---|
| System erratic and/or noisy | Air in system due to low oil level in reservoir | Replenish with 10W30 API SE/CD oil. |
| | Air in system due to leak at suction fitting | Check fittings and tighten. |
| | Internal pump or motor wear caused by overspeeding | Consult your dealer or Hyundai Service Dept. |
| | Excessive play in linkage or pintle lever | Adjust linkage and tighten or replace pintle lever. |
| Machine will not travel in a straight line in high range | Control levers binding | Check that shields are not stopping lever from full travel. |
| | | Check for linkage binding at spring mount. Adjust tracking. |

2. Hydraulic System

| PROBLEM | CAUSE | REMEDY |
|--|---|---|
| Loss of hydraulic power (no flow from gear pump) | Reservoir low on fluid hose or fitting leak. | Replenish with 10W30 or 20W50 API SE/CD oil. Check for leaks. |
| | Flexible coupling between engine and pump failure | Inspect and replace damaged parts. Check for misalignment between engine and pumps. |
| | Spline coupling failure between front and rear hydrostatic pump | Inspect coupling for sheared splines. Also check pump shaft bearings. |
| | Hydraulic gear pump not functioning | Inspect and repair. |
| Loss of hydraulic power (flow from gear pump) | Reservoir low on fluid | Replenish with 10W30 or 20W50 API SE/CD oil. |
| | Foot pedal linkage disconnected or binding | Inspect and adjust. |
| | Auxiliary foot pedal engaged | Disengage |
| | Relief valve failure in control valve | Check pressure and adjust. |
| Hydraulic action jerky | Reservoir low on oil | Replenish with 10W30 API or 20W50 SE/CD oil. |
| | Air in hydraulic system | Check for leak between reservoir and pump. Bleed System by extending and retracting lift cylinders several times. |

4...MAINTENANCE

| | | |
|--|---|--|
| Lift arms raise slowly at full engine rpm | Anti-cavitation check valve not functioning | Inspect and repair or replace |
| | Reservoir low on oil | Replenish with 10W30 or 20W50 API SE/CD oil |
| | Foot pedal linkage binding | Inspect and adjust |
| | Auxiliary foot pedal engaged | Disengage |
| | Engine RPM too slow | Check RPM and reset |
| | Anti-cavitation check valve spring broken | Replace |
| | Main relief valve in control valve faulty | Check pressure if necessary - adjust |
| | Internal leakage in pump due to wear | Check pump flow and repair or replace as necessary |
| Lift or tilt cylinders will not support a load | Oil bypassing one or both lift cylinder piston seals | Install new piston seal kits |
| | External leak between or at control valve and cylinders | Check for leaks and correct |
| | Control valve spool not centering | Check for sticking foot pedal linkage |
| | | Check for broken or stuck return spring on valve spool |
| | Oil leaking by one or both cylinder piston seals | Install new piston seal kits |
| Hydraulic oil overheating | Reservoir low on fluid | Replenish with 10W30 or 20W50 API SE/CD oil |
| | Auxiliary foot pedal engaged | Disengage |
| | Engine RPM too slow | Check RPM and adjust |
| | Incorrect temperature sensor | Replace |

| | | |
|-------------------------------------|--------------------------------------|---|
| Foot pedals do not operate smoothly | Foot pedal linkage out of adjustment | Adjust foot pedal linkages |
| | Foot pedal linkages need lubrication | Lubricate with a silicone based lubricant |
| | Cable Binding | Check routing for kinks etc. |

| | | |
|------------------------------------|------------------------------|---|
| <i>3. Final Drive Transmission</i> | | |
| Final drive transmission noisy | No lubricating oil | Check and bring oil to the proper level. Use 10W30 SE/CD engine oil |
| | Axles have too much end play | Pre-load axle bearings removing all end play |
| | Chain loose | Replace the chain |
| | | |

| | | |
|--|---|---|
| <i>4. Control Levers</i> | | |
| Control levers will not centre | Linkage out of adjustment | Adjust, check for wear at rod ends, loose counter nuts |
| | Linkage disconnected | Reconnect, check for wear at rod ends, loose counter nuts |
| | Centering spring broken | Replace |
| | Linkage binding | Binding of spring bushing in spring box. Align spring box with linkage. |
| | | Control levers binding with safety shields or sound insulation Adjust |
| Machine operates erratically | | Control lever bearings binding in lever assy. Inspect replace or clean as required |
| | Control lever linkage loose | Inspect linkage for wear at rod ends, loose counter nuts |
| | Spiral pin in pintle lever worn or broken | Replace pin. Inspect pintle lever for wear at pin hole. Ensure bolt clamping lever to pump shaft is tight |
| | | See hydrostatic system |
| Machine will not travel in straight line | Linkage binding | Adjust |
| | Control lever travel out of adjustment | Adjust |

4...MAINTENANCE

| 4. Control Levers | | |
|--|--|--|
| Control levers do not operate smoothly | Internal pump and/or motor leakage | See troubleshooting hydrostatic system |
| | Control lever linkages out of adjustment | Adjust control lever linkages |

| 5. Park Brake | | |
|--------------------------------|---|---|
| Brake will not hold machine | Brake valve will not release pressure | Verify position of override Sect 4.6 - 5 |
| | Brake parts damaged or worn | Consult your Dealer or Hyundai Service Dept. |
| | Brakes are disengaged | Engage parking brake |
| Brake will not release machine | No power to brake valve solenoid | Check fuse. If fine, consult Dealer or Hyundai Service Dept. |
| | No pressure in supply line to brake valve | Consult your Dealer or Hyundai service Dept. |
| | Brakes are engaged | Release brake |

| 6. Electrical | | |
|---|---|--|
| Engine will not crank over | Battery failure | Check battery, charge or replace |
| | Battery cable failure | Check for loose or corroded connectors. tighten and clean as required. Use di-electric grease to prevent corrosion. |
| | | Check continuity of cables and replace if defective |
| | Starter failure | Repair or replace |
| | Fuse burnt | Check and replace |
| | Defective relay | Check relay continuity if defective, replace |
| Engine cranks over, but will not start | Ignition switch failure | Check continuity and if defective, replace |
| | Auxiliary hydraulics engaged | Engine will smoke but not run unassisted by starter. Disengage aux. hydraulics |
| | Defective glow plug relay | Check continuity and if defective, replace |
| | Defective glow plugs | Check continuity and if defective, replace |
| | Broken connection or defective wire | Disconnect the ROPS harness from the engine harness. Open the dash panel and check continuity of the circuit not functioning properly in both engine and ROPS harness. |
| | No fuel | Check fuel levels and system |
| | Loader starts, but foot pedals will not release | Electro solenoids not releasing valve spools |
| Engine will not stop when the key is turned OFF | Defective fuel solenoid switch | Check and correct |

4...MAINTENANCE

7. Diesel Engine

| SYMPTOM | PROBABLE CAUSE | SOLUTION |
|---|---|--|
| Engine does not start | No fuel | Replenish fuel |
| | Air in the fuel | Vent air |
| | Water in the fuel | Change fuel and repair or replace fuel system |
| | Fuel pipe clogged | Clean |
| | Fuel filter clogged | Clean or change |
| | Excessively high viscosity of fuel or engine oil at low temperature | Use the specified fuel or engine oil |
| | Fuel with low cetane number | Use the specified fuel |
| | Fuel leak due to loose injection pipe retaining nut | Tighten nut |
| | Incorrect injection timing | Adjust |
| | Fuel cam shaft worn | Replace |
| | Injection nozzle clogged | Clean |
| | Injection pump malfunctioning | Repair or replace |
| | Seizure of crankshaft, camshaft, piston, cylinder liner or bearing | Repair or replace |
| | Compression leak from cylinder | Replace head gasket, tighten cylinder head bolt, glow plug and nozzle holder |
| | Improper valve timing | Correct or replace timing gear |
| | Piston ring and liner worn | Replace |
| Starter does not run | Excessive valve clearance | Adjust |
| | Battery discharged | Charge |
| | Starter malfunctioning | Repair or replace |
| | Key switch malfunctioning | Repair or replace |
| Engine revolution is not smooth | Wiring disconnected | Connect |
| | Fuel filter clogged or dirty | Clean or change |
| | Air cleaner clogged | Clean or change |
| | Fuel leak due to loose injection pipe retaining nut | Tighten nut |
| | Injection pump malfunctioning | Repair or replace |
| | Incorrect nozzle opening pressure | Adjust |
| | Injection nozzle stuck or clogged | Repair or replace |
| | Fuel overflow pipe clogged | Clean |
| Governor malfunctioning | Repair | |
| Either white or blue exhaust gas is observed | Excessive engine oil | Reduce to the specified level |
| | Low grade fuel used | Repair or replace |
| | Fuel filter clogged | Adjust |
| | Air cleaner clogged | Adjust top clearance |
| Either black or dark gray exhaust gas is observed | Overload | Lessen the load |
| | Low grade fuel used | Use the specified fuel |
| | fuel filter clogged | Clean or change |
| | air cleaner clogged | Clean or change |
| | | |

4...MAINTENANCE

7. Diesel Engine

| SYMPTOM | PROBABLE CAUSE | SOLUTION |
|--|---|--|
| Excessive lubricant oil consumption | Piston rings gap facing the same direction | Shift gap direction |
| | Oil ring worn or stuck | Replace |
| | Piston ring groove worn | Replace |
| | Valve stem and guide worn | Replace |
| | Crankshaft bearing and crank pin bearing worn | Replace |
| Fuel mixed into lubricant oil | Injection pump plunger worn | Replace pump element or pump |
| | Injection pump broken | Replace |
| Water mixed into lubricant oil | Head gasket defective | Replace |
| | Cylinder block or cylinder head flawed | Replace |
| Low oil pressure | Engine oil insufficient | Replenish |
| | Oil strainer clogged | Clean |
| | Relief valve stuck with dirt | Clean |
| | Relief valve spring weakened or broken | Replace |
| | Excessive oil clearance of crankshaft bearing | Replace |
| | Excessive oil clearance of crank pin bearing | Replace |
| | Excessive oil clearance of rocker arm bearing | Replace |
| | Oil passage clogged | Clean |
| High oil pressure | Oil pump defective | Use the specified oil type |
| | Different type of oil | Use the specified oil type |
| | Relief valve defective | Replace |
| Engine overheated | Engine oil insufficient | Replenish |
| | Fan belt broken or elongated | Change or adjust |
| | Cooling water insufficient | Replenish |
| | Radiator net and radiator fin clogged with dust | Clean |
| | Inside of radiator corroded | Clean or replace |
| | Cooling water flow route corroded | Clean or replace |
| | Radiator cap defective | Replace |
| | Overload running | Loosen the load |
| | Head gasket defective | Replace |
| | Incorrect injection timing | Adjust |
| | Unsuitable fuel used | Use the specified fuel |
| | Deficient output | Incorrect injection timing |
| Engine's moving parts seem to be seizing | | Repair or replace |
| Uneven fuel injection | | Repair or replace injection pump |
| Deficient nozzle injection | | Repair or replace nozzle |
| Compression leak | | Replace head gasket, tighten cylinder head bolt, glow plug and nozzle holder |
| Battery quickly discharges | Battery electrolyte insufficient | Replenish distilled water recharge |
| | Fan belt slips | Adjust belt tension or change |
| | Wiring disconnected | Connect |
| | Rectifier defective | Replace |
| | Alternator defective | Replace |
| | Battery defective | Change |





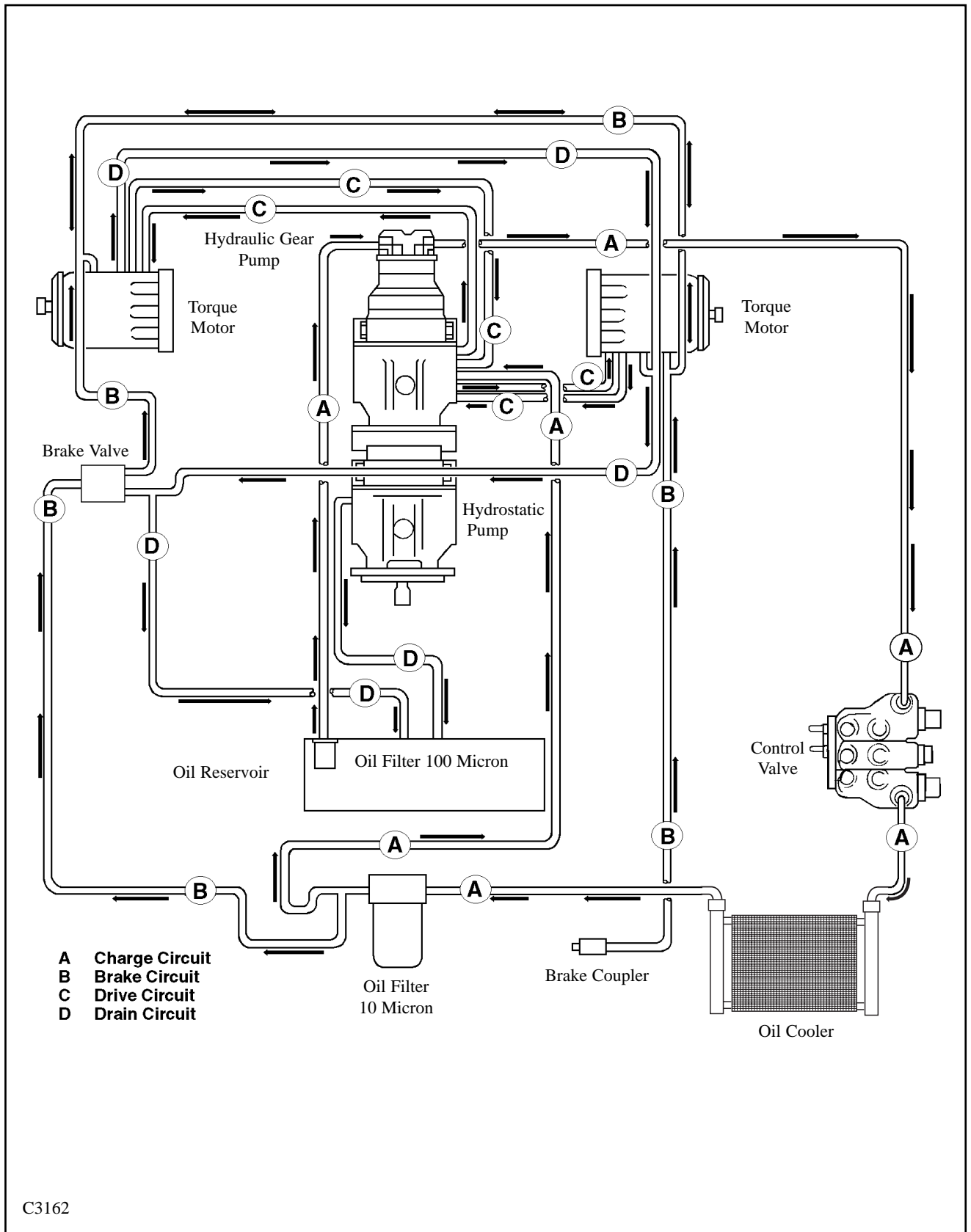

4...MAINTENANCE

4.12 HYDRAULIC/HYDROSTATIC CIRCUIT

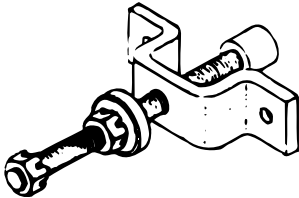

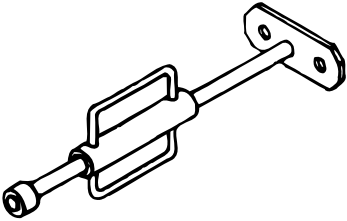

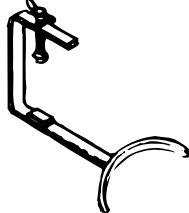
4...MAINTENANCE

4.13 SPECIAL TOOLS

| P/N | ILLUSTRATION | DESCRIPTION | MODEL |
|------------------|---|---|--------------------|
| 955280 |  | AXLE INSTALLATION TOOL - To install axle in final drive housing. Quantity - 1 | HSL600T |
| 960849 955281 |  | SEAL INSTALLATION TOOL - To install axle seal in final drive housing. Quantity - 3 required | HSL500T HSL600T |
| 955283 |  | AXLE EXTRACTOR TOOLS- To remove axle from final drive housing. Quantity - 2 | ALL LOADERS |
| 955287 |  | SEAL INSTALLATION TOOL - To install axle seal in final drive housing. Quantity - 1 | HSL800T |
| 957189 |  | SEAL INSTALLATION TOOL - To install axle seal in final drive housing. Quantity - 1 | |
| 959849 |  | CHAIN TENSION TOOL - To test chain tension. | HSL500T HSL600T |
| U-1288 | Universal Tool Kit | 1 each. Combination wrench 7/16", 1/2", 9/16", 11/16" 3/4", 1 1/16", 1 1/4". Sockets, 1", 1/2" drive, 7/8", 1/2" drive, tool pouch, allen wrench 5/32" and 1/8" | ALL MODELS |

4...MAINTENANCE

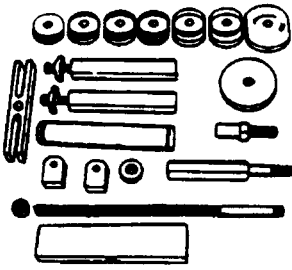
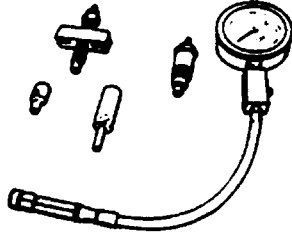
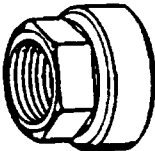
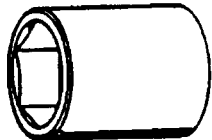
4.13 SPECIAL TOOLS

| Order # | Illustration | Description | Models |
|-------------------------------|---|--|------------|
| 916 - 30042-01 25197 |  | DRY LINER PULLER - Used for removing and installing the dry liner of the engine. Consists of: 304742 (64mm); 304743 (68mm); 30744 (75mm) 304745 (76mm); 304746 (82mm); 304747 (105mm); Removing Plates; 304748 Installing Plate | KUBOTA |
| 07909 - 30202-01 25198 |  | DIESEL ENGINE COMPRESSION TESTER - Used to measure diesel engine compression and diagnosis of need for major overhaul. | KUBOTA |
| 07916 - 30820-01 25199 |  | CRANKSHAFT NUT SOCKET - Used to take off and fix the crankshaft nut. (46 mm). | KUBOTA |
| 07916 - 30840-01 25200 |  | NOZZLE REMOVER SOCKET - Used to unfasten the screw type nozzle holders. | KUBOTA |
| 70090 - 01125-01 25201 |  | NOZZLE DISASSEMBLY SOCKET - Used in place of a vice for disassembly and repair of nozzles. | KUBOTA |
| 960456 |  | HYDRAULIC FLOW AND PRESSURE GAUGE ASSEMBLY. | All Models |

4...MAINTENANCE

4.13 SPECIAL TOOLS

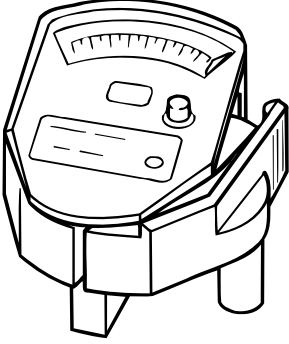
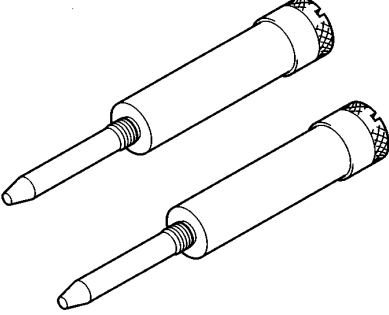
| Order # | Illustration | Description | Models |
|---------|--|---|--------|
| 42530 |  | TOOTHED BELT TENSION GAUGE Quantity -1 | |
| 42531 |  | ADJUSTING PIN FOR CRANKSHAFT AND CAMSHAFT | |
| | | | |

5...SPECIFICATIONS

5...SPECIFICATIONS

- 5. 1 Loader Specifications
- 5. 2 Torque Specifications
- 5. 3 Sound Power Level
- 5. 4 Decals, Warning

5...SPECIFICATIONS

5.1 LOADER SPECIFICATIONS

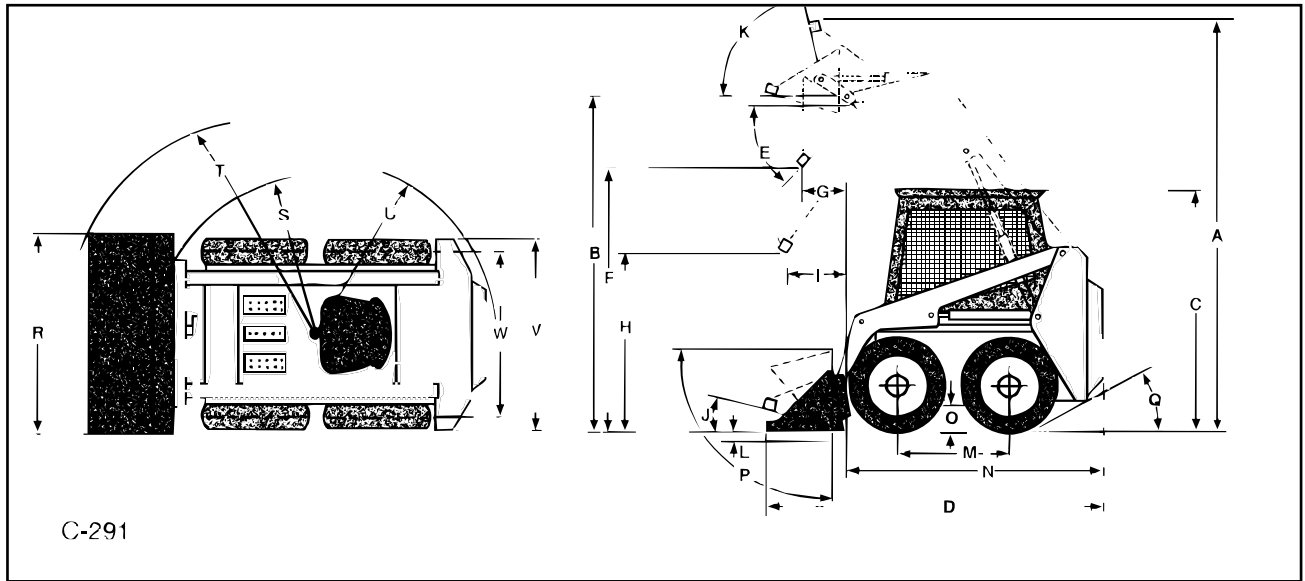

Dimensions – 5. 1: (With Std. Tires & Dirt Bucket)

| | |
|---|-------------------|
| A. Overall operating height | 134. 5" (3416 mm) |
| B. Height to hinge pin | 102.5" (2604 mm) |
| C. Overall vehicle height with ROPS | 71" (1803 mm) |
| D. Overall length with bucket | 115" (2921 mm) |
| E. Dump angle | 30° |
| F. Dump height | 81.5" (2070 mm) |
| G. Reach — fully raised | 22.75" (578 mm) |
| H. Height at 45° dump angle | 54.75" (1391 mm) |
| I. Reach at 45° dump angle | 27" (686 mm) |
| J. Maximum roll back at ground | 32° |
| K. Maximum roll back fully raised | 97° |
| M. Wheel base | 33.18" (843 mm) |
| N. Overall length less bucket | 91" (2311 mm) |
| O. Ground clearance | 6.75" (171 mm) |
| P. Maximum grading angle – bucket | 80° |
| Q. Angle of departure | 23° |
| R. Bucket width | 48" (1219mm) |
| S. Clearance circle – front – less bucket | 41" (1041 mm) |
| T. Clearance circle – front – with bucket | 66.25" (1683 mm) |
| U. Clearance circle – rear | 54" (1372 mm) |
| V. Overall width – less bucket | 47.75" (1213 mm) |
| W. Tread | 38.5" (978) |

Performance

| | |
|--------------------------|------------------------------|
| Rated operating capacity | 1000 lbs. (454 kg) |
| Operating weight | 3650 lbs. (1656 kg) |
| Shipping weight | 3150 lbs. (1429 kg) |
| Speed | 3000 RPM 5.8 mph (9.3 km/hr) |
| Tipping Load | 2100 lbs. (953 kg) |

5...SPECIFICATIONS

Controls

VEHICLE: Steering direction and speed controlled by two hand operated control levers.

HYDRAULICS: Lift, bucket tilt and auxiliary hydraulic functions controlled by separate foot pedals.

ENGINE: Hand lever throttle, engine stop and key type ignition switch.

Engine

Make and modelKubota V1305B
 Cylinders.....4
 Cooling systemLiquid
 Displacement81.5 cu. in. (1335 cc)
 Horsepower (kW)33.5 (25)
 ISO Net.....22.5 kW @ 3000 RPM
 Torque43.4 ft. lbs (6 kg/M)
 Fuel type.....Diesel No. 2
 Air cleaner.....Replaceable Dry Cartridge
w/ indicator
 Maximum governed RPM (no load).....3000 RPM

Hydraulic System

Pump typeGear
 Pump capacity.....8.7 GPM / 3000 RPM
33 L/M / 3000 RPM
 Control valve Parallel type with float on lift and
detent on auxiliary
 System relief pressure (Zero Flow) 2150 PSI
 (148 Bar)
 Filtration 5 micron
 Hydraulic fluid 10W30 API Class, SE/CD
20W50 API Class, SE/CD
 Oil Cooler.....250 BTU/min (264 kJ/min)

| | | |
|---------------------------|-----------|-----------|
| Cylinders (double acting) | Lift | Tilt |
| Bore dia. | 2 in. | 2 in. |
| Rod dia. | 1.125 in. | 1.125 in. |

Hydrostatic Transmission & Final Drive

Pump type Two in line, axial piston
 Pump displacement 1.5 cu. in. (25 cm³)
 Motor type Geroler, torque motor
 System relief setting3625 PSI (250 Bar)
 Final drive No. 60 HT roller chain
running in an oil bath

Electrical

Alternator60A
 Battery12 V
 Type34/78
 Cranking amps.....730
 Reserve capacity.....125
 Starter.....12 V

Tires

Standard8.50 x 15, 4 ply
 Flotation10.50 x 15, 4 ply
30 - 35 PSI (207 - 241 kPa)

Fluid Capacities

Fuel tank11.3 gal. (43 L)
 Final drive transmission5.9 gal. (22.3 L)
 Hyd. Reservoir9 gal (34 L)
 Engine cooling system3.2 gal. (12.1 L)
 Engine oil.....9.0 qt (8.5 L)

5.4 DECAL CHART

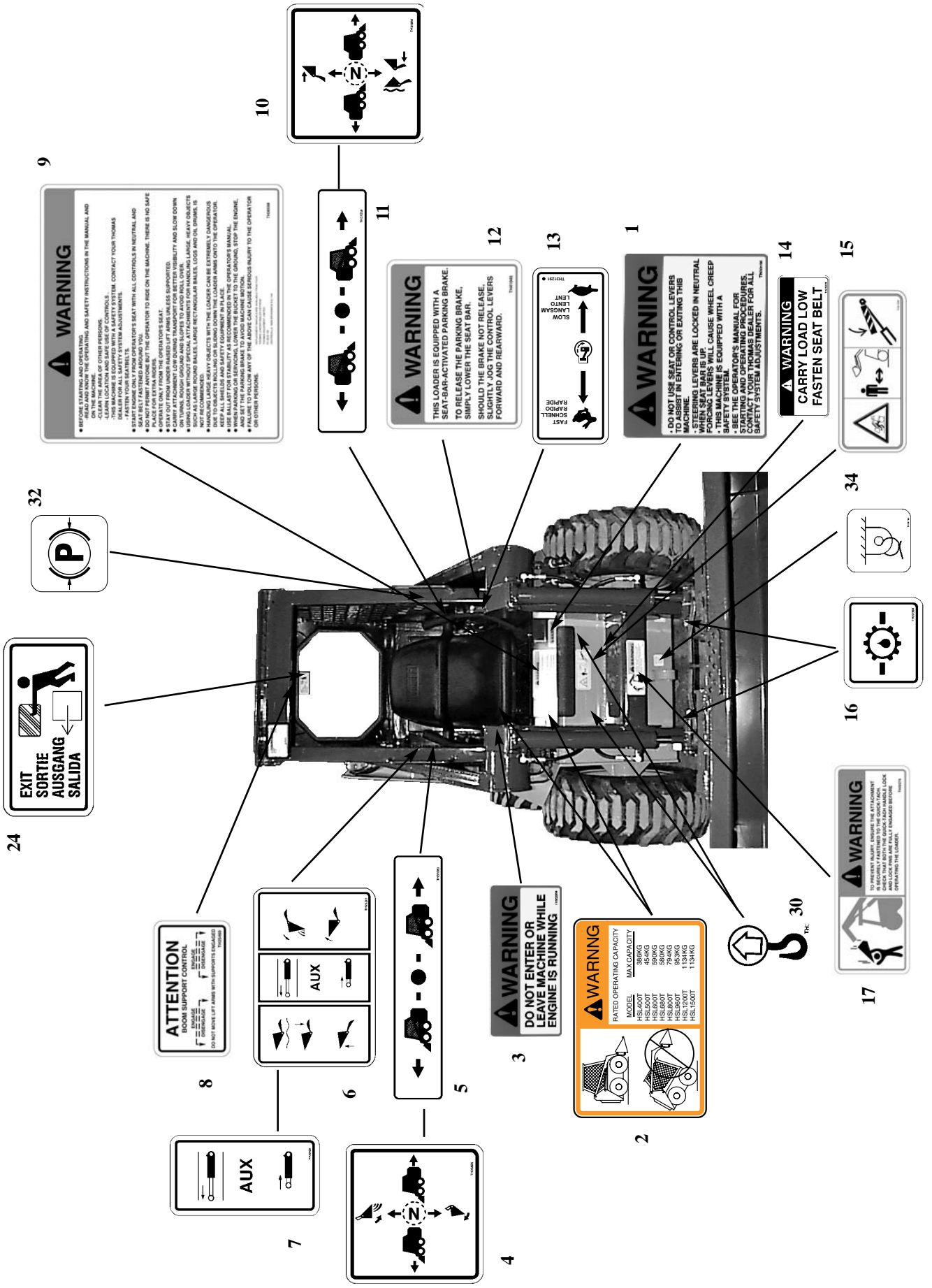

WARNING

BEFORE STARTING AND OPERATING:
 - READ AND KNOW THE OPERATING AND SAFETY INSTRUCTIONS IN THE MANUAL AND
 - CLEAR THE AREA OF OTHER PERSONS.
 - THIS MACHINE IS EQUIPPED WITH A SAFETY SYSTEM. CONTACT YOUR THOMAS
 DEALER FOR ALL SAFETY SYSTEM ADJUSTMENTS.
 - START ENGINE ONLY FROM OPERATOR'S SEAT WITH ALL CONTROLS IN NEUTRAL AND
 - DO NOT PERMIT ANYONE BUT THE OPERATOR TO RISE ON THE MACHINE. THERE IS NO SAFE
 PLACE FOR EXTRA RIDERS.
 - STAY OUT FROM UNDER RAISED LIFT ARMS UNLESS SUPPORTED.
 - USE SAFETY BELT AND SEAT BELT. ALWAYS WEAR YOUR SAFETY BELT AND SLOW DOWN
 ON TIGHT, SLOPING, UNLEVEL AND SLOTTED SURFACES.
 - USING LARGER WITHOUT SPECIAL ATTACHMENTS FOR HANDLING LARGE, HEAVY OBJECTS
 IS NOT RECOMMENDED.
 - HANGING LARGE (EMPTY) OBJECTS WITH THE LOADERS CAN BE EXTREMELY DANGEROUS
 AND CAUSE THE FORK LIFTS TO FALL. ALWAYS USE THE OPERATOR'S MANUAL.
 - KEEP ALL SHIELDS AND SAFETY EQUIPMENT IN PLACE.
 - WHEN PARKING OR SERVICING, LOWER THE BUCKET TO THE GROUND, STOP THE ENGINE,
 AND SET THE PARKING BRAKE TO AVOID MACHINE MOTION.
 - ALWAYS WEAR YOUR SAFETY BELT AND SEAT BELT.
 - ON OTHER PERSONS.

WARNING

THIS LOADER IS EQUIPPED WITH A SEAT-BAR-ACTIVATED PARKING BRAKE. TO RELEASE THE PARKING BRAKE, SIMPLY LOWER THE SEAT BAR. SHOULD THE BRAKE NOT RELEASE, SLIGHTLY JOG THE CONTROL LEVERS FORWARD AND REARWARD.

WARNING

DO NOT USE SEAT OR CONTROL LEVERS TO ASSIST IN ENTERING OR EXITING THIS MACHINE. CONTROL LEVERS ARE LOCKED IN NEUTRAL WHEN SEAT BAR IS UP. FORCING LEVERS WILL CAUSE WHEEL CREEP.
 THIS MACHINE IS EQUIPPED WITH A SAFETY SYSTEM. CONTACT YOUR THOMAS DEALER FOR ALL SAFETY SYSTEM ADJUSTMENTS.

WARNING

CARRY LOAD LOW
 FASTEN SEAT BELT

WARNING

DO NOT ENTER OR LEAVE MACHINE WHILE ENGINE IS RUNNING

WARNING

RATED OPERATING CAPACITY

| MODEL | MAX. CAPACITY |
|----------|---------------|
| HSL5500T | 4500KG |
| HSL5600T | 4500KG |
| HSL6000T | 5000KG |
| HSL6500T | 5500KG |
| HSL6600T | 7000KG |
| HSL6800T | 7500KG |
| HSL6900T | 8500KG |
| HSL7200T | 11000KG |
| HSL7500T | 11300KG |

WARNING

THE OPERATOR'S MANUAL FOR THIS MACHINE IS ESSENTIAL TO THE SAFE OPERATION OF THE MACHINE. ALWAYS READ AND FOLLOW THE INSTRUCTIONS IN THE OPERATOR'S MANUAL BEFORE OPERATING THE LOADER.

5. 4 DECAL CHART

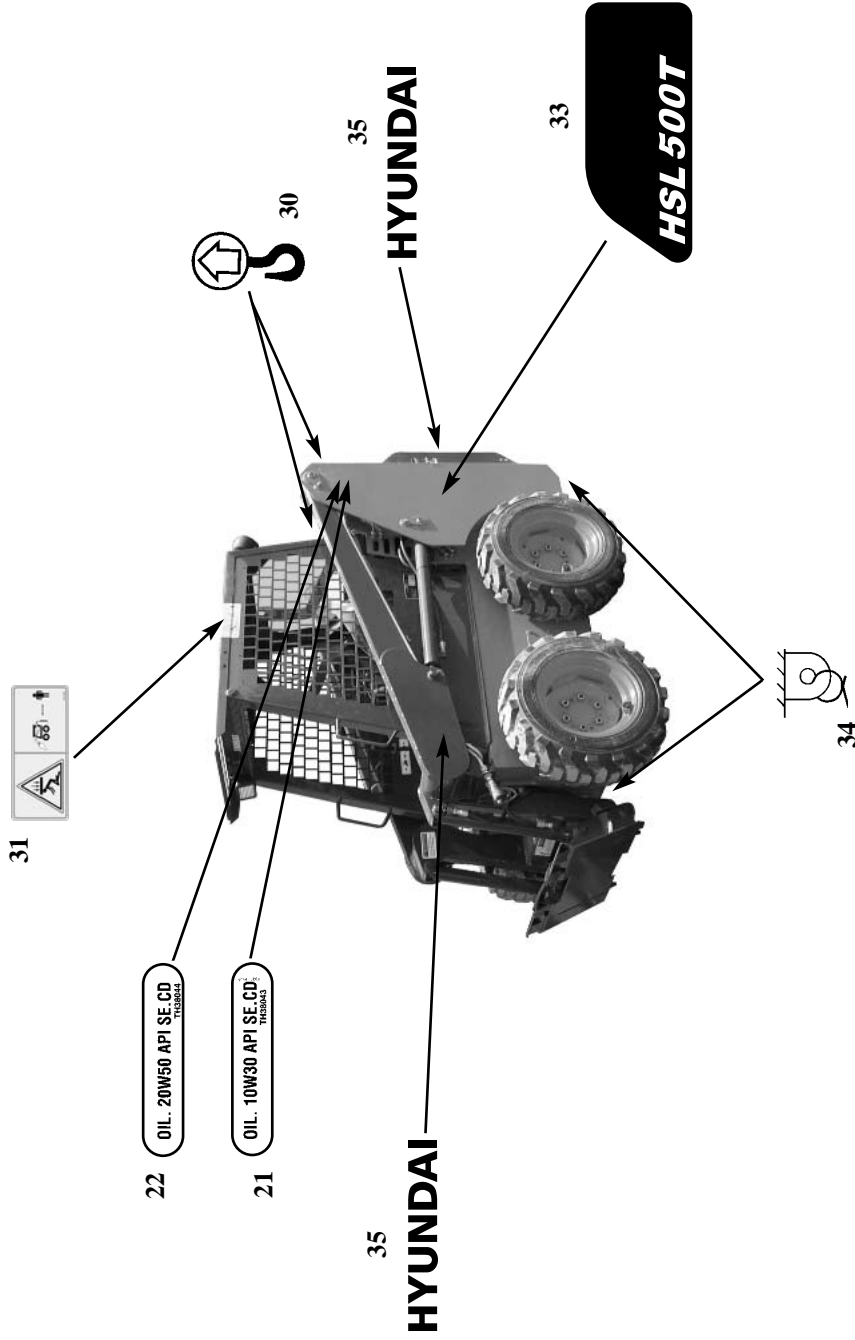

T105 DECAL PARTS LIST

| | | | | | | | | | |
|----|-------|-----|-------|-----|-------|-----|-------|-----|-------|
| 1. | 39196 | 10. | 35885 | 19. | 23308 | 27. | 23310 | 35. | 52328 |
| 2. | 42107 | 11. | 37059 | 20. | 23307 | 28. | 23325 | 36. | 37010 |
| 3. | 23324 | 12. | 41045 | 21. | 38043 | 29. | 43144 | 37. | 42108 |
| 4. | 35886 | 13. | 31291 | 22. | 38044 | 30. | 39191 | | |
| 5. | 37060 | 14. | 23326 | 23. | 23312 | 31. | 41065 | | |
| 6. | 23301 | 15. | 41066 | 24. | 36841 | 32. | 43145 | | |
| 7. | 35935 | 16. | 23309 | 25. | 23321 | 33. | 52337 | | |
| 8. | 25460 | 17. | 32275 | 26. | 41064 | 34. | 39192 | | |
| 9. | 36598 | | | | | | | | |

6...ATTACHMENTS AND BUCKETS

6...ATTACHMENTS AND BUCKETS

6. 1 Hyundai Approved Buckets and Attachments

6...ATTACHMENTS AND BUCKETS

6.1 HYUNDAI APPROVED BUCKETS AND ATTACHMENTS

BUCKETS - DIRT/CONSTRUCTION

| Cat. # | Description | SAE Heaped Capacity (ft ³) | Approx. Weight |
|--------|---------------------|--|----------------|
| 2093 | 48 inch Dirt Bucket | 8.8 | 274 lb. |
| 2059 | 54 inch Bucket | 9.9 | 301 lb. |

PALLET FORK

| Cat. # | Description | Approx. Weight |
|--------|------------------------------------|----------------|
| 2096 | Pallet Fork Frame (Requires Tines) | 120 lb. |
| 99 | 30" Tines (Set of Two) | 110 lb. |
| 98 | 36" Tines (Set of Two) | 138 lb. |
| 437 | 42" Tines (Set of Two) | 149 lb. |
| 2564 | 48" Tines (Set of Two) | 160 lb. |

HYDRAULIC BREAKER

| Cat. # | Description | Approx. Weight |
|--------|--|----------------|
| 1536 | HH 150-150 ft. lb. Class Hydraulic Breaker | 250 lb. |
| 1693 | Side Plates | 120 lb. |
| 2144 | Breaker Mount | 190 lb. |
| 1530 | Moil Point - HH150 | 25 lb. |
| 1531 | Chisel Point - HH150 | 25 lb. |
| 1532 | Blunt Point - HH150 | 25 lb. |
| 1567 | Asphalt Point - HH150 | 25 lb. |
| 1568 | Tamping Pad 8x8 - HH150 | 70 lb. |
| 1548 | Gas Charger | 2 lb. |