

## 6. SERVICE INSTRUCTION

### 1) CHECK ENGINE OIL LEVEL

Check the oil level with the machine on a flat ground before starting engine.

- (1) Pull out the dipstick and wipe with a clean cloth.
- (2) Check the oil level by inserting the dipstick completely into the hole and pulling out again.
- (3) If oil level is LOW, add oil and then check again.
  - ※ If the oil is contaminated or diluted, change the oil regardless of the regular change interval.
  - ※ Check oil level after engine has been stopped for 15 minutes.
  - ▲ Do not operate unless the oil level is in the normal range.

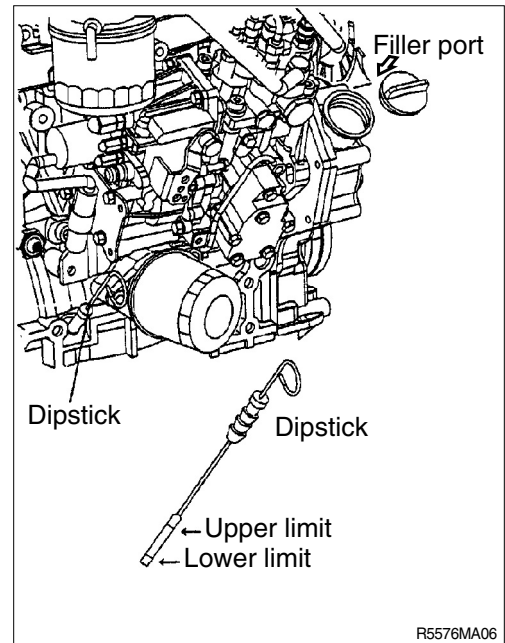

### 2) REPLACEMENT OF ENGINE OIL AND OIL FILTER

- (1) Warm up the engine.
- (2) Remove the cover of drain plug and connect the quick coupler hose.
  - ※ A drain pan with a capacity of 20 liters(5 U.S. gallons) will be adequate.
  - ▲ Use API CI-4 or better grade oil.

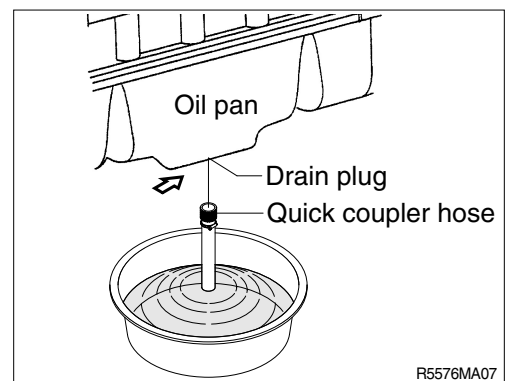

- (3) Clean around the filter head, remove the filter with a filter wrench and clean the gasket surface.

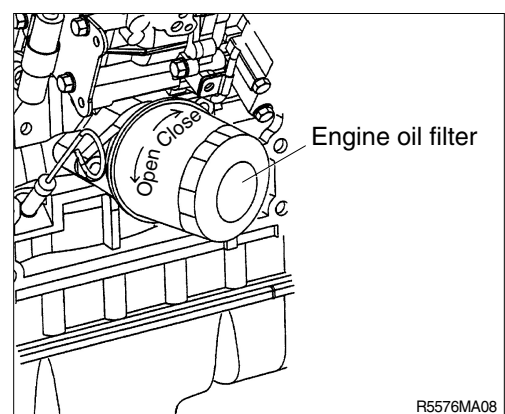

- (4) Apply a light film of lubricating oil to the gasket sealing surface before installing the filters.

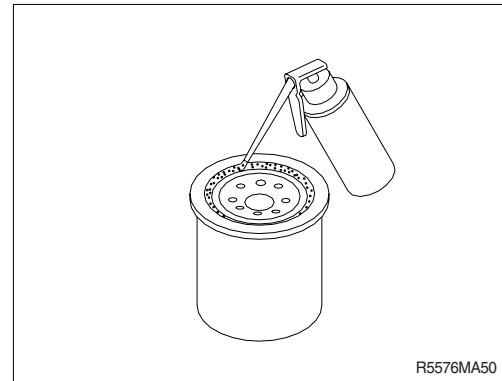

- (5) Install the filter to the filter head.  
Remove the quick coupler hose.  
※ **Mechanical over-tightening may distort the threads or damage the filter element seal.**  
· Install the filter as specified by the filter manufacturer.

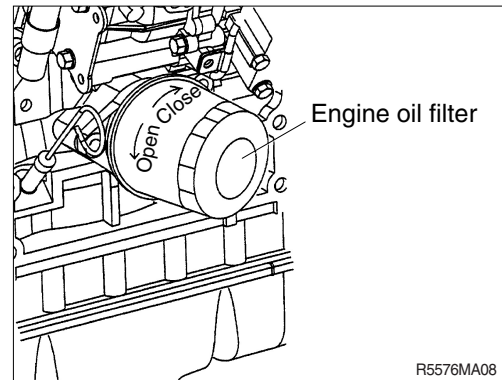

- (6) Fill the engine with clean oil to the proper level.  
· Quantity : 11.6 l (3.1U.S.gallons)

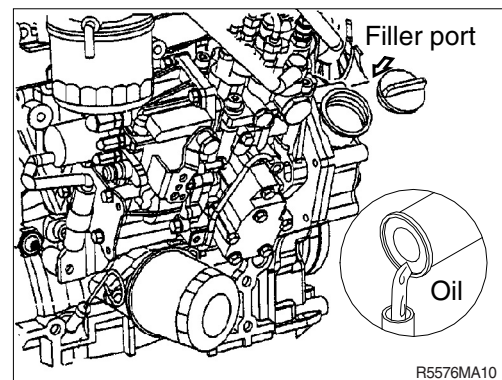

- (7) Operate the engine at low idle and inspect for leaks at the filters and the drain plug.  
Shut the engine off and check the oil level with the dipstick. Allow 15minutes for oil to drain down before checking.

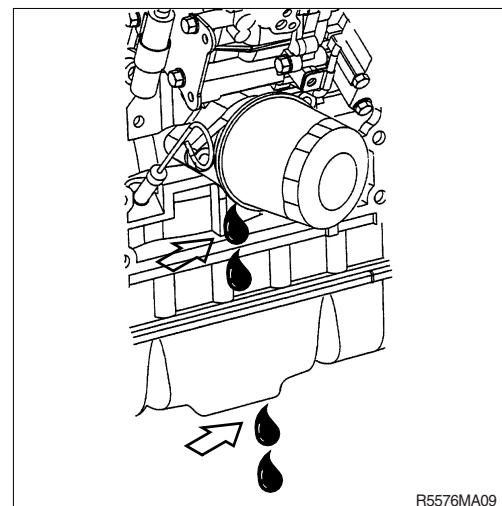

### 3) CHECK COOLANT

- (1) Check if the level of coolant in reservoir tank is between FULL and LOW.
- (2) Add the mixture of antifreeze and water after removing the cap of the reservoir tank if coolant is not sufficient.
- (3) Be sure to add the coolant by opening the cap of radiator when coolant level is below LOW.
- (4) Replace gasket of radiator cap when it is damaged.

**▲ Hot coolant can spray out if radiator cap is removed while engine is hot. Remove the cap after the engine has cooled down.**

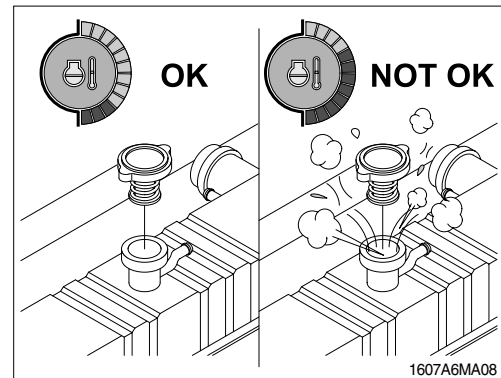
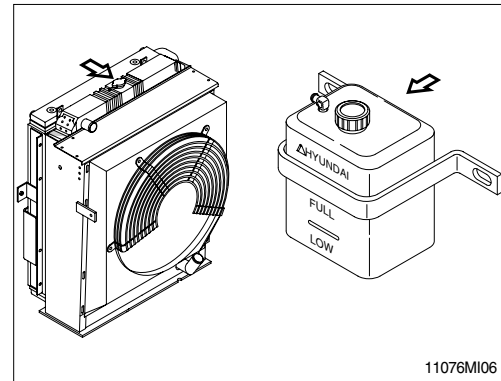

### 4) FLUSHING AND REFILLING OF RADIATOR

- (1) Change coolant

**▲ Avoid prolonged and repeated skin contact with used antifreeze. Such prolonged repeated contact can cause skin disorders or other bodily injury.**

**Avoid excessive contact-wash thoroughly after contact.**

**Keep out of reach of children.**

**※ Protect the environment : Handling and disposal of used antifreeze can be subject to federal, state, and local law regulation.**

**Use authorized waste disposal facilities, including civic amenity sites and garages providing authorized facilities for the receipt of used antifreeze.**

**If in doubt, contact your local authorities for guidance as to proper handling of used antifreeze.**

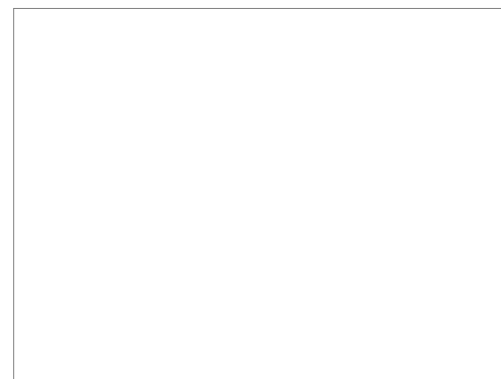
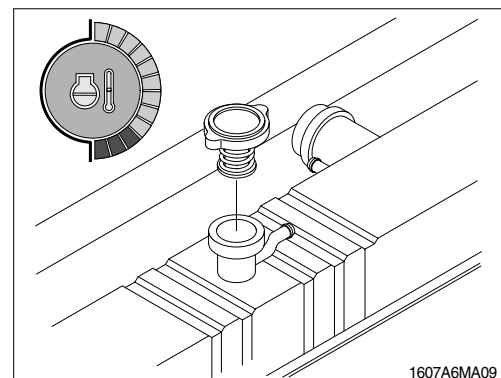

**▲ Wait until the temperature is below 50°C (122°F) before removing the coolant system pressure cap.**

**Failure to do so can cause personal injury from heated coolant spray.**

Drain the cooling system by opening the drain valve on the radiator and removing the plug in the bottom of the water inlet. A drain pan with a capacity of 17.5 liters(4.6U.S.gallons) will be adequate in most applications.

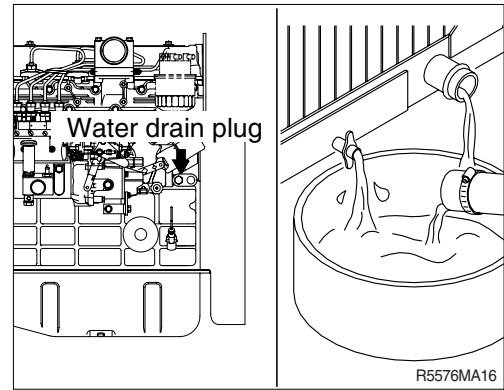

## (2) Flushing of cooling system

① Fill the system with a mixture of sodium carbonate and water(or a commercially available equivalent).

※ Use 0.5kg(1.0pound) of sodium carbonate for every 23 liters(6.0U.S. gallons) of water.

※ Do not install the radiator cap. The engine is to be operated without the cap for this process.

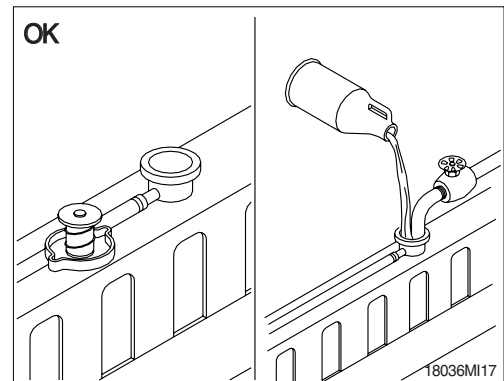

② Operate the engine for 5 minutes with the coolant temperature above 80°C(176°F) .

Shut the engine off, and drain the cooling system.

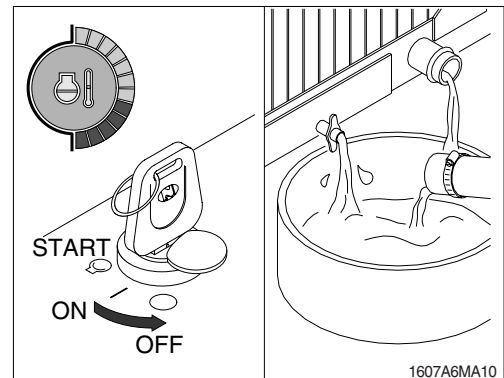

③ Fill the cooling system with clean water.

※ Be sure to vent the engine and aftercooler for complete filling.

※ Do not install the radiator cap or the new coolant filter.

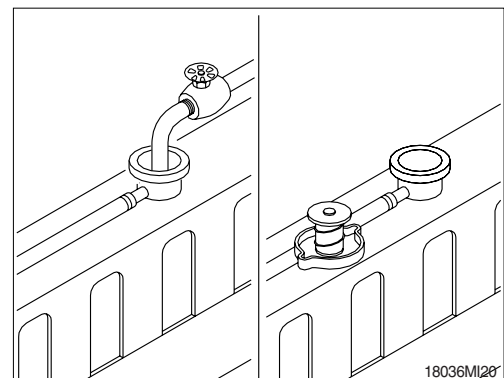

- ④ Operate the engine for 5 minutes with the coolant temperature above 80°C(176°F) . Shut the engine off, and drain the cooling system.
- ※ If the water being drained is still dirty, the system must be flushed again until the water is clean.

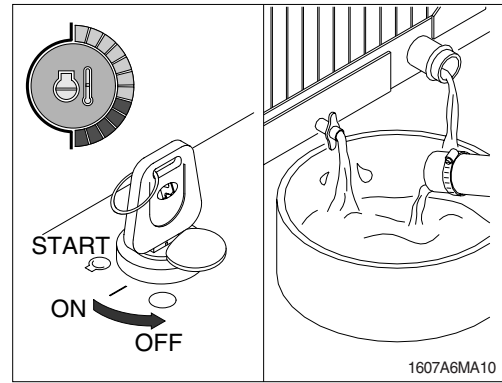

### (3) Cooling system filling

- ① Use a mixture of 50 percent water and 50 percent ethylene glycol antifreeze to fill the cooling system.  
Coolant capacity(engine only) : 4.2 l (1.1U.S. gallons)
  - ※ Use the correct amount of DCA4 corrosion inhibitor to protect the cooling system.
  - ※ The system must be filled slowly to prevent air locks.
- During filling, air must be vented from the engine coolant passage.

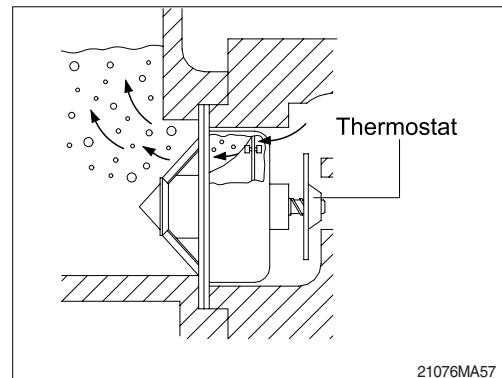
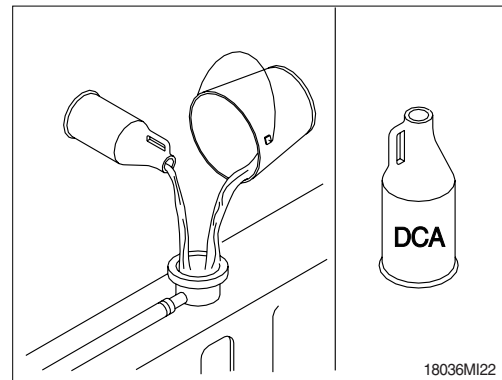

- ③ Install the pressure cap. Operate the engine until it reaches a temperature 80°C (176°F), and check for coolant leaks. Check the coolant level again to make sure the system is full of coolant.

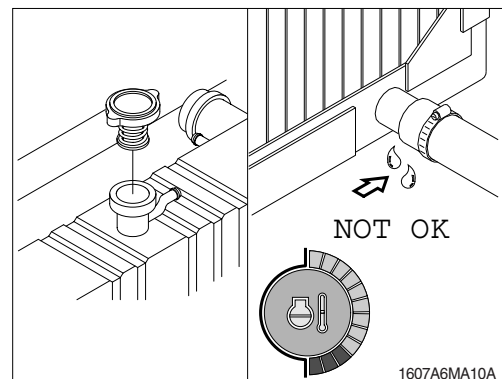

## 5) CLEAN RADIATOR AND OIL COOLER

Check, and if necessary, clean and dry outside of radiator and oil cooler. After working in a dusty place, clean radiator more frequently.

- (1) Visually inspect the radiator for clogged radiator fins.
- (2) Use 550kPa(80psi) air pressure to blow the dirt and debris from the fins.  
Blow the air in the opposite direction of the fan air flow.
- (3) Visually inspect the radiator for bent or broken fins.  
※ **If the radiator must be replaced due to bent or broken fins which can cause the engine to overheat, refer to the manufacturer's replacement procedures.**
- (4) Visually inspect the radiator for core and gasket leaks.

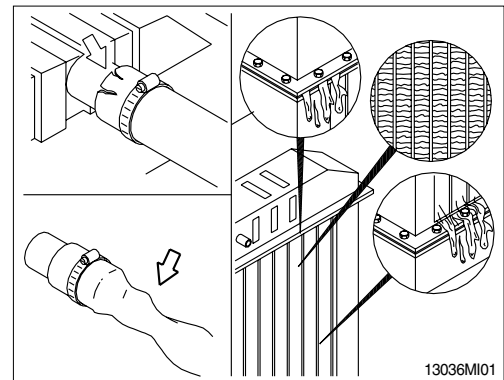
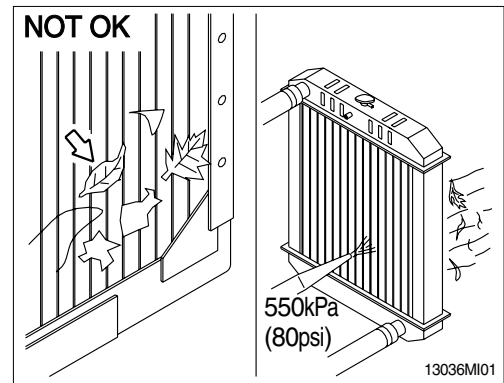

## 6) FAN BELT TENSION

- (1) Measure the belt deflection at the longest span of the belt.

· Deflection

Unit : mm

Item	A	B	C
Used belt	10~14	7~10	9~13
New belt	8~12	5~8	7~11

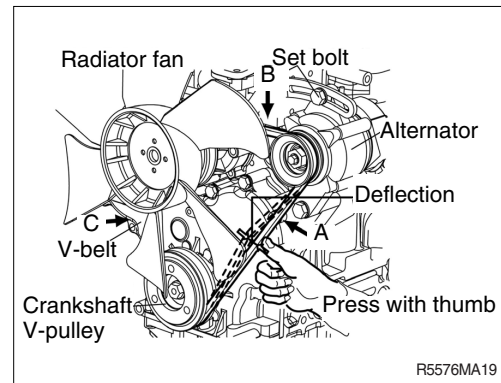

- (2) Inspect the drive for damage.

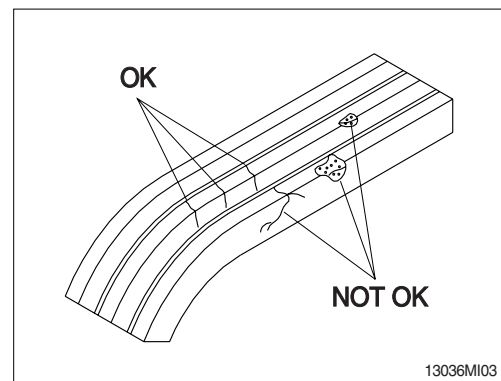

## 7) INSPECTION OF COOLING FAN

**▲ Personal injury can result from a fan blade failure. Never pull or pry on the fan. This can damage the fan blade and cause fan failure.**

※ Rotate the crankshaft by using the engine barring gear.

※ A visual inspection of the cooling fan is required daily.

Check for cracks, loose rivets, and bent or loose blades.

Check the fan to make sure it is securely mounted. Tighten the capscrews if necessary.

Replace any fan that is damaged.

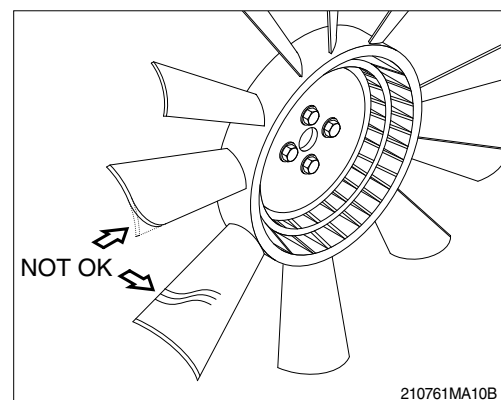

## 8) CLEANING OF AIR CLEANER

### (1) Primary element

- ① Open cover and remove the element.
  - ② Clean the inside of the body.
  - ③ Clean the element with pressurized air.
    - Remove the dust inside of the element by the pressurized air (Below  $3\text{kgf/cm}^2$ , 40psi) forward and backward equally.
  - ④ Inspect for cracks or damage of element by putting a light bulb inside of the element.
  - ⑤ Insert element and close cover.
- ※ **Replace the primary element after 4 times cleanings.**

### (2) Safety element

- ※ **Replace the safety element only when the primary element is cleaned for the 4 times.**
- ※ **Always replace the safety element. Never attempt to reuse the safety element by cleaning the element.**

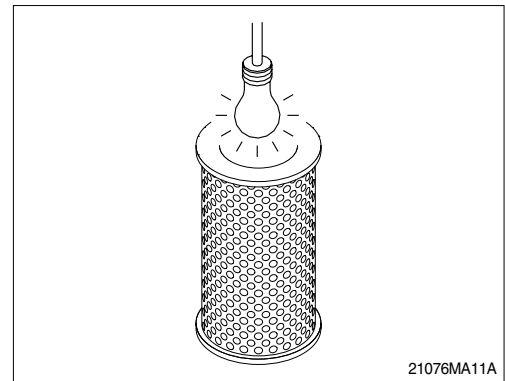
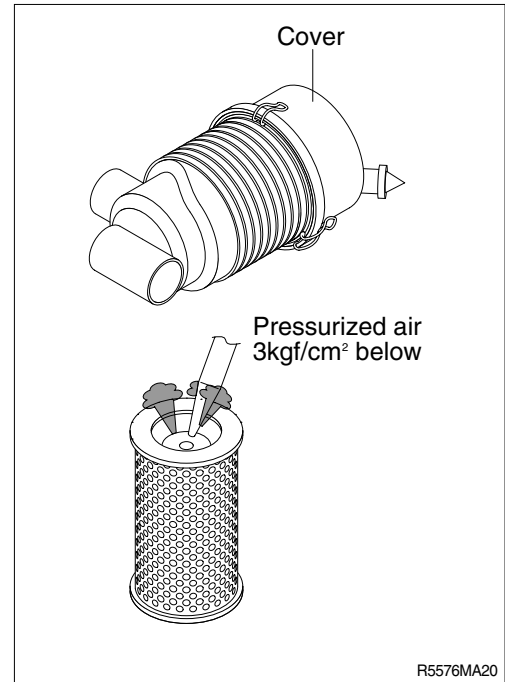

## 9) FUEL TANK

- (1) Fill fuel fully when system the operation to minimize water condensation, and check it with fuel gauge before starting the machine.
  - (2) Drain the water and sediment in the fuel tank by opening the drain cock.
    - ※ **Be sure to LOCK the cap of fuel tank.**
    - ※ **Remove the strainer of the fuel tank and clean it if contaminated.**
- ▲ **Stop the engine when refueling.**  
All lights and flames shall be kept at a safe distance while refueling.

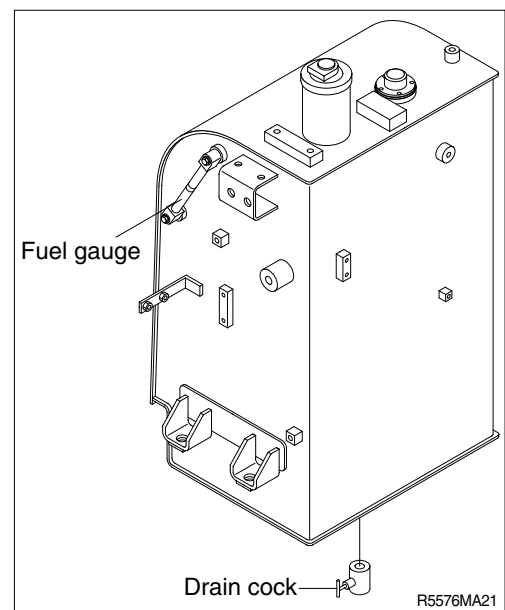

## 10) PREFILTER

- ※ Inspect or drain the collection bowl of water daily and replace the element every 500hours.

### (1) Drain water

- ① Open bowl drain valve to evacuate water.
- ② Close drain valve.

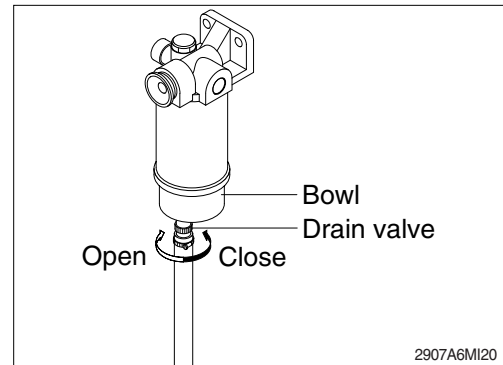

### (2) Replace element

- ① Drain the unit of fuel. Follow "Drain water" instructions above.
  - ② Remove element, fuel warmer and bowl from filter head.
- ※ The bowl is reusable, do not damage or discard.
- ③ Separate element from bowl. Clean bowl and seal gland.

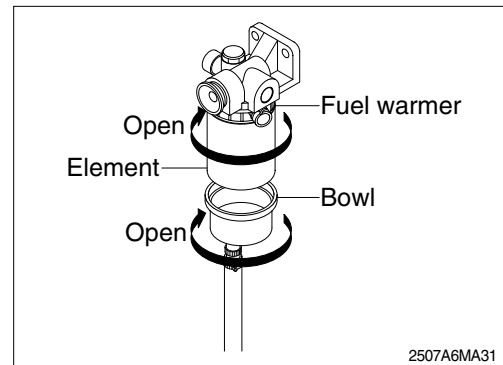

- ④ Lubricate new bowl seal with clean fuel or motor oil and place in bowl gland.
- ⑤ Attach bowl to new element firmly by hand.
- ⑥ Lubricate new element seal and place in element top gland.
- ⑦ Attach the element, fuel warmer and bowl to the head.

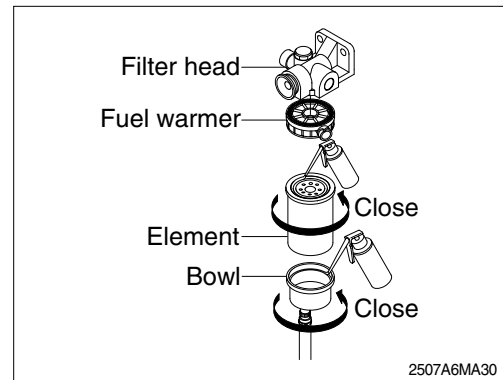

## 11) REPLACEMENT OF FUEL FILTER

- (1) Clean around the filter head, remove the filter with a filter wrench and clean the gasket surface.
- (2) Apply a small amount of fuel to the O-ring of new cartridge.
- (3) Install new cartridge by hand.
  - ※ Do not add fuel to the new cartridge. Invisible particles of dirt which might get inside the injection pump can damage its finely finished parts.
- (4) Relieve the air after mounting.
  - ※ Check for fuel leakage after the engine starts.
  - ※ If air is in the fuel system, the engine will not start. Start engine after bleeding the air according to the method of bleeding air.

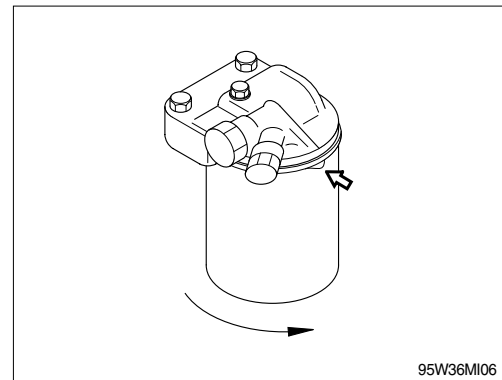
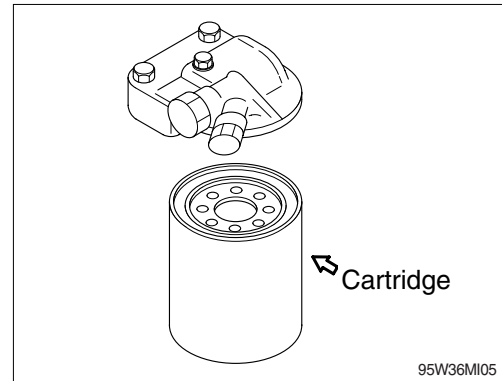

## 12) BLEEDING THE FUEL SYSTEM

- (1) Turn the start switch to the ON position and hold it in the position for 10~15 seconds to operate the fuel feed pump.

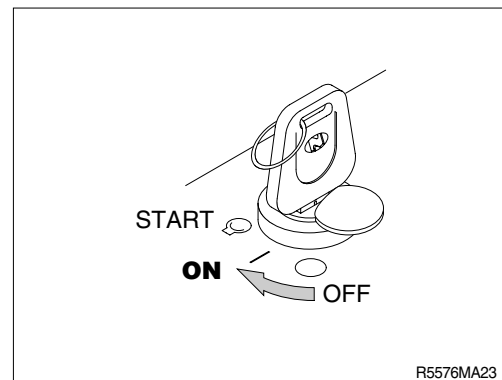

## 13) LEAKAGE OF FUEL

- ▲ Be careful and clean the fuel hose, injection pump, fuel filter and other connections as the leakage from these part can cause fire.

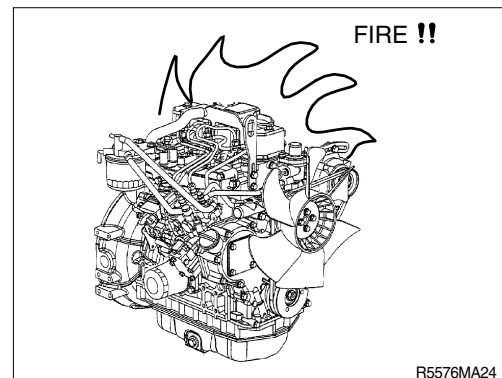

#### 14) HYDRAULIC OIL CHECK

- (1) Stop the engine after retract the arm and bucket cylinders, then lower the boom and set the bucket on the ground at a flat location as in the illustration.
- (2) Check the oil level at the level gauge of hydraulic oil tank.
- (3) The oil level is normal if between the red lines.

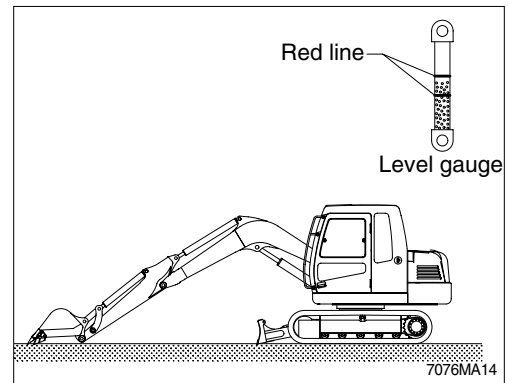

#### 15) FILLING HYDRAULIC OIL

- (1) Stop the engine to the position of level check.
- (2) Loosen the cap and relieve the pressure in the tank by pushing the top of the air breather.
- (3) Remove the breather on the top of oil tank and fill the oil to the specified level.
  - Tightening torque :  $1.44 \pm 0.3 \text{kgf} \cdot \text{m}$   
( $10.4 \pm 2.1 \text{lb} \cdot \text{ft}$ )
- (4) Start engine after filling and operate the work equipment several times.
- (5) Check the oil level at the level check position after engine stops.

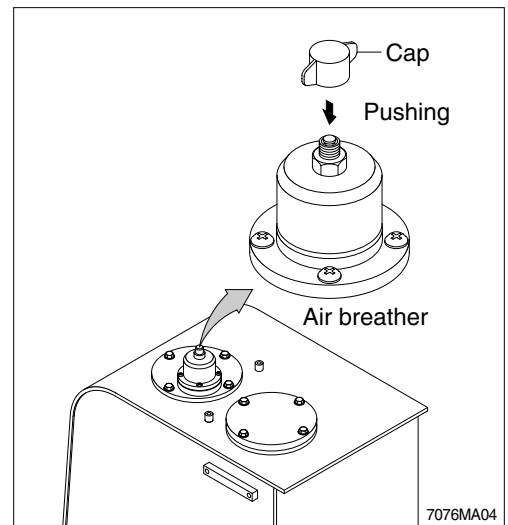

#### 16) CHANGE HYDRAULIC OIL

- (1) Lower the bucket on the ground pulling the arm and bucket cylinder to the maximum.
- (2) Loosen the cap and relieve the pressure in the tank by pushing the top of the air breather.
- (3) Remove the cover.
  - Tightening torque :  $6.9 \pm 1.4 \text{kgf} \cdot \text{m}$   
( $50 \pm 10 \text{lb} \cdot \text{ft}$ )
- (4) Prepare a suitable container.
- (5) To drain the oil loosen the drain plug at the bottom of the oil tank.
- (6) Fill proper amount of recommended oil.
- (7) Put the breather in the right position.
- (8) Bleed air hydraulic pump loosen the air breather at top of hydraulic pump assembly.**
- (9) Start engine and run continually. Release the air by full stroke of each control lever.

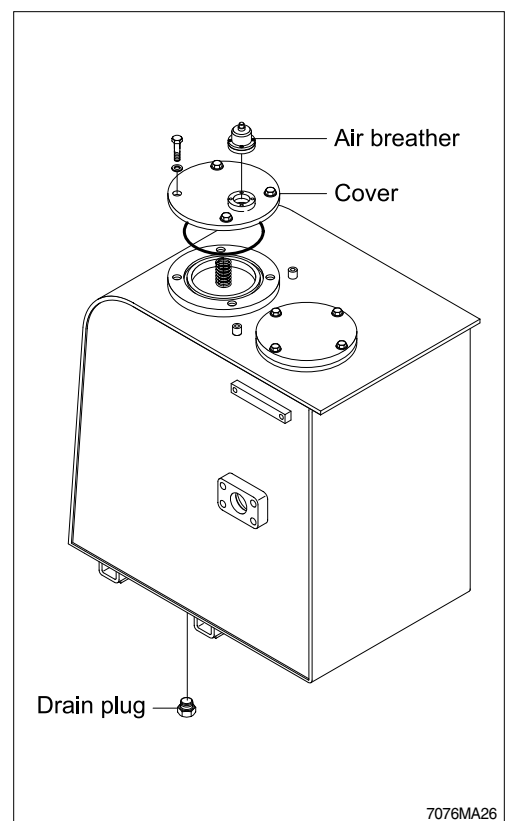

## 17) CLEAN SUCTION STRAINER

Clean suction strainer as follows paying attention to the cause to be kept during oil filling.

- (1) Remove the cover on the top of the oil tank.
    - Tightening torque :  $6.9 \pm 1.4 \text{kgf} \cdot \text{m}$   
( $50 \pm 10 \text{lbf} \cdot \text{ft}$ )
  - (2) Pull out the strainer in the tank.
  - (3) Wash the foreign material on the suction strainer with gasoline or cleaning oil.
  - (4) Replace the suction strainer if it is damaged.
  - (5) Assemble with reverse order of disassembly.  
Be sure to install a new O-ring and reinsert in the oil tank.
- ※ **Loosen the bolt slowly at the cover can be spring out by the spring when removing it.**

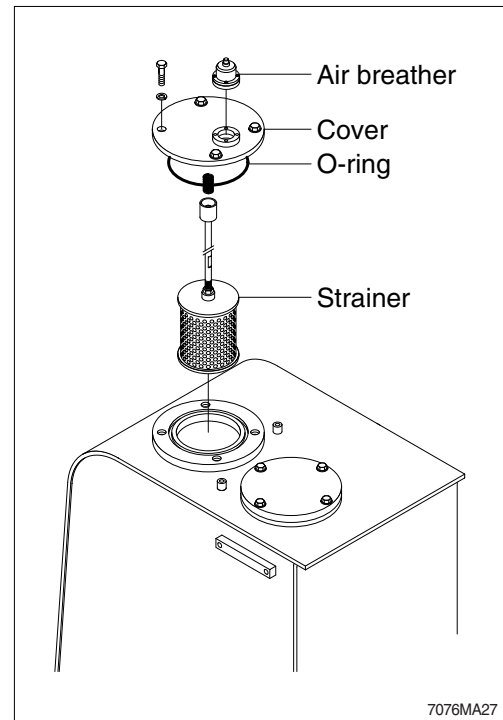

## 18) REPLACEMENT OF RETURN FILTER

Replace as follows paying attention to the cause to be kept during the replacement.

- (1) Remove the cover.
  - Tightening torque :  $6.9 \pm 1.4 \text{kgf} \cdot \text{m}$   
( $50 \pm 10 \text{lbf} \cdot \text{ft}$ )
- (2) Remove the spring, by-pass valve, and return filter in the tank.
- (3) Replace the element with new one.

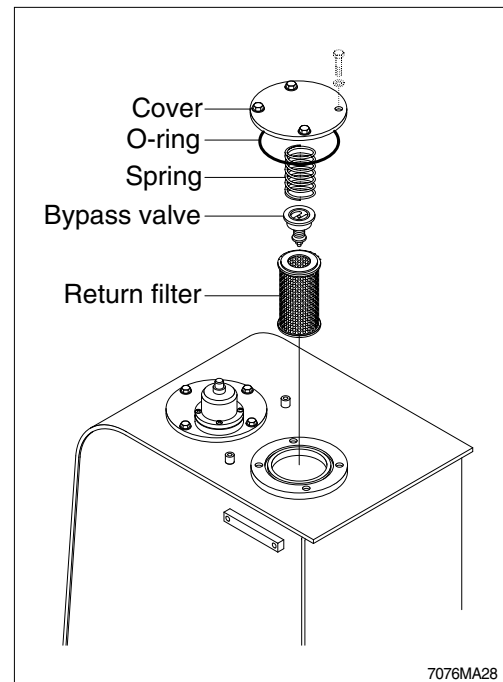

### 19) REPLACEMENT OF ELEMENT IN HYDRAULIC TANK BREATHER

- (1) Loosen the cap and relieve the pressure in the tank by pushing the top of the air breather.
- (2) Loosen the lock nut and remove the cover.
- (3) Pull out the filter element.
- (4) Replace the filter element new one.
- (5) Apply oil on the O-ring and reassemble by reverse order of disassembly.
  - Tightening torque : 0.2~0.3kgf · m  
(1.4~2.1lbf · ft)

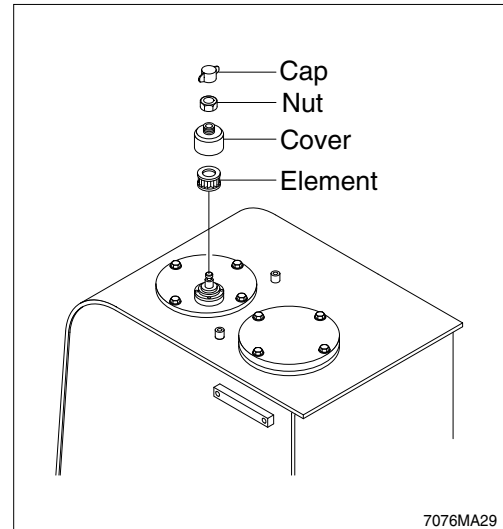

### 20) REPLACE OF PILOT LINE FILTER

- (1) Loosen the nut positioned on the filter body.
  - (2) Pull out the filter element and clean filter housing.
  - (3) Install the new element and tighten using specified torque.
- ※ **Change cartridge after initial 50 hours of operation. Thereafter, change cartridge every 250 hours.**

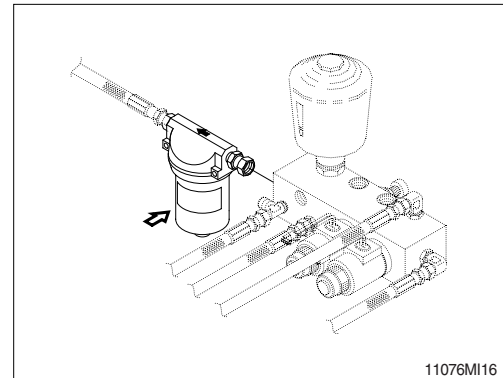

### 21) CHECK THE SWING REDUCTION GEAR OIL

- (1) Pull out the dipstick and clean it.
- (2) Insert it again.
- (3) Pull out one more time to check the oil level and fill the oil if the level is not sufficient.

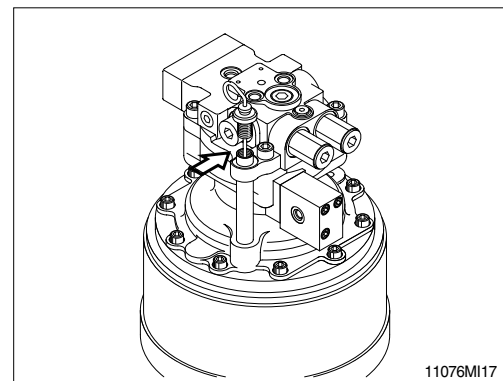

## 22) CHANGE SWING REDUCTION GEAR OIL

- (1) Raise the temperature of oil by swinging the machine before replace the oil and park the machine on the flat ground.
- (2) Loosen the plug of the drain port.
- (3) Drain into a proper container.
- (4) Wash the drain plug and reinstall it with sealing tape.  
Fill proper amount of recommended oil.  
· Amount of oil : 2.5 l (0.7U.S.gal)

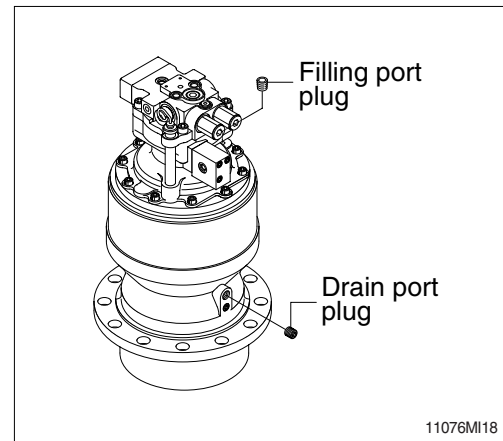

## 23) LUBRICATE BEARING OF OUTPUT SHAFT IN REDUCTION GEAR

- (1) Remove air vent plug.
- (2) Remove grease fill plug and install grease fitting at that place.
- (3) Lubricate NLGI No.2 with grease gun until comes out new grease from air vent port.  
※ Lubricate every 1000 hours.

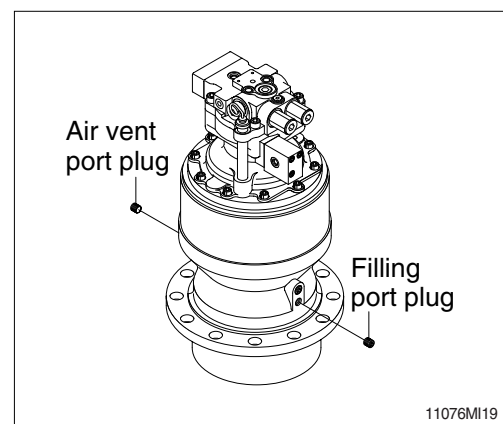

## 24) LUBRICATE SWING BEARING

- (1) Grease at 3 fitting.
- ※ Lubricate every 50 hours.

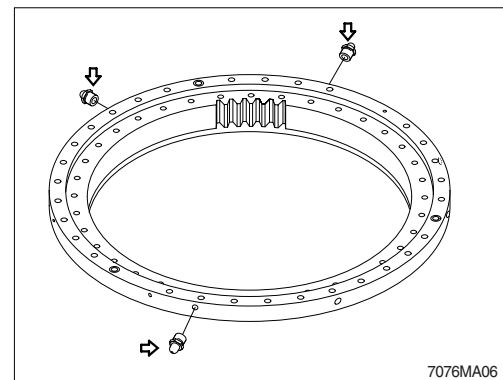

## 25) SWING GEAR AND PINION

### (1) Drain old grease

- ① Remove under cover of lower frame.
- ② Remove drain cover of lower frame.
- ③ Remove filler cover of upper frame.
- ④ Operate full turn(360°) of swing several times.

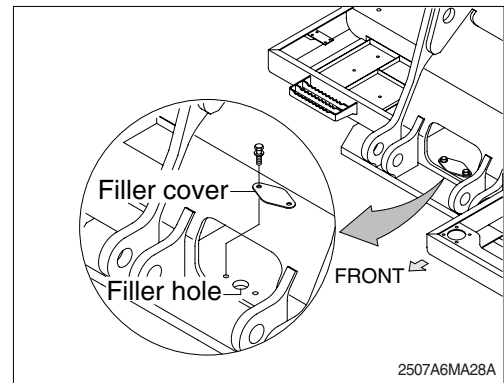

### (2) Refill new grease

- ① Install drain cover.
  - ② Fill with new grease.
  - ③ Install filler cover.
- Capacity : 1.8kg(4.0lb)

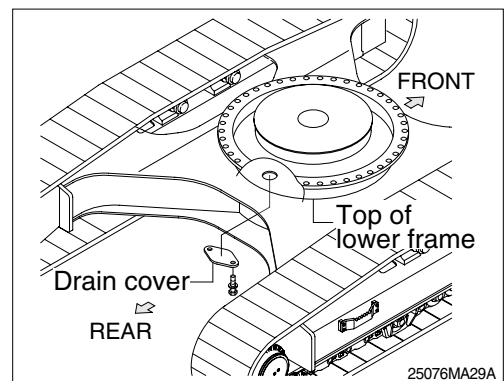

## 26) CHECK THE TRAVEL REDUCTION GEAR OIL

- (1) Operate the machine to the position of drain plug down to the flat ground.
- (2) Loosen the level plug and check the oil level.  
If the level is at the hole of the plug, it is normal.  
Fill the oil if it is not sufficient.  
Amount of oil : 1.2 l (0.32 U.S.gal)

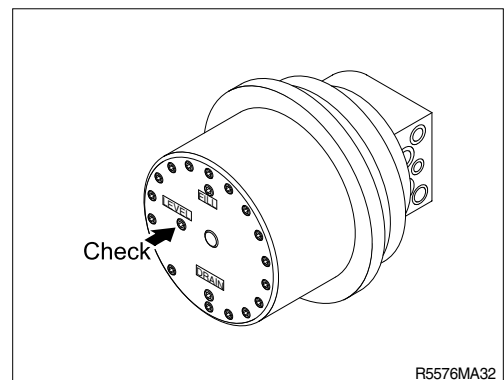

## 27) CHANGE OF THE TRAVEL REDUCTION GEAR OIL

- (1) Raise the temperature of the oil by traveling machine first.
- (2) Stop when the position of the drain plug is down.
- (3) Loosen the level plug and then the drain plug.
- (4) Drain the oil to adequate container.
- (5) Tighten the drain plug and fill specified amount of oil at filling port.
- (6) Tighten the level plug and travel slowly to check if there is any leakage of oil.

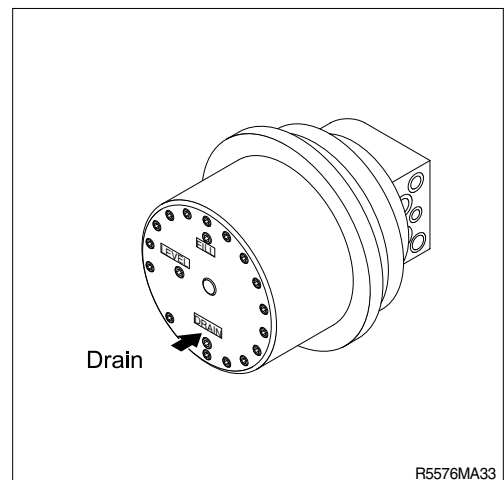

## 28) LUBRICATE RCV LEVER

Remove the bellows and with a grease gun grease the joint part(A) and sliding parts(B).

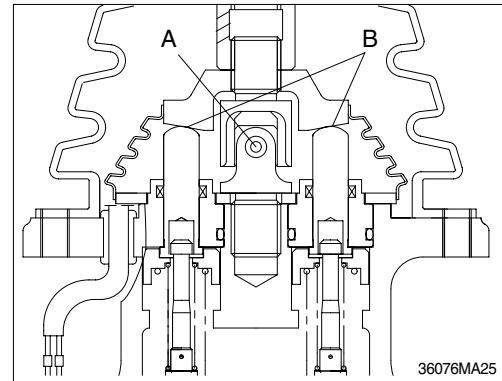

## 29) ADJUSTMENT OF TRACK TENSION

- ※ It is important to adjust the tension of track properly to extend the lifetime of track and traveling device.
- ※ The wear of pins and bushings on the undercarriage will vary with the working conditions and soil properties.  
It is thus necessary to continually inspect the track tension so as to maintain the standard tension on it.

- (1) Raise the chassis with the boom and arm.
- (2) Measure the distance between bottom of track frame on track center and track of shoe.
- ※ Remove mud with rotating the track before measuring.

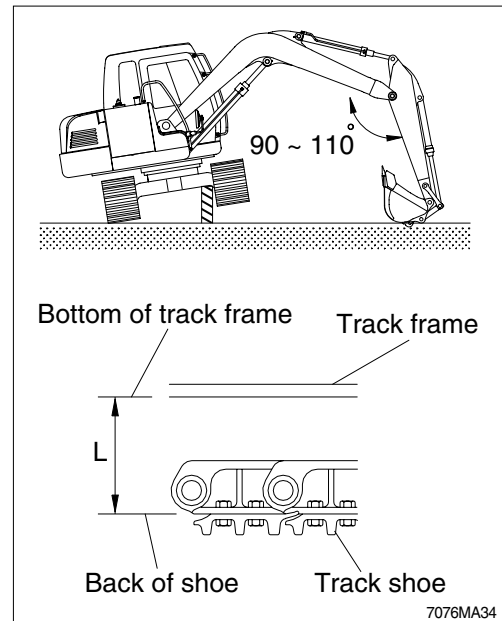

- (3) If the tension is tight, drain the grease in the grease nipple and if the tension is loose, charge the grease.

- ▲ Personal injury or death can result from grease under pressure.
- ▲ When loosening the grease nipple, do not loosen more than one turn as there is a danger of a spring coming out of the nipple because of the high pressure inside.
- ※ When the grease is drained, move the track to the forward and backward slightly.  
If the track tension is loose even after the grease is charged to the maximum, change the pins and bushings as there are worn seriously.

Length(L)	
210~240mm	8.3"~9.4"

### 30) REPLACEMENT OF BUCKET

▲ When knocking the pin in with a hammer, metal particles may fly and cause serious injury, particularly if they get into your eyes. When carrying out this operation, always wear goggles, helmet, gloves, and other protective equipment.

※ When the bucket is removed, place it in a stable condition.

※ When performing joint work, make sure signals to each other and work carefully for safety's sake.

(1) Lower the bucket on the ground as the picture shown in the right.

(2) Lock the safety lever to the LOCK position and stop the engine.

(3) Remove the stopper bolts(1) and nuts(2), then remove pins(3, 4) and remove the bucket.

※ When removing the pins, place the bucket so that it is in light contact with the ground.

※ If the bucket is lowered strongly to the ground, the resistance will be increased and it will be difficult to remove the pins.

※ After remove the pins, make sure that they do not become contaminated with sand or mud and that the seals of bushing on both sides do not become damaged.

(4) Align the arm with holes(A) and the link with holes(B), then coat with grease and install pins(3, 4)

※ When installing the bucket, the O-rings are easily damaged, so fit the O-rings on the boss of the bucket as shown in the picture. After knocking the pin, move the O-ring down to the regular groove.

(5) Install the stopper bolt(1) and nuts(2) for each pin, then grease the pin.

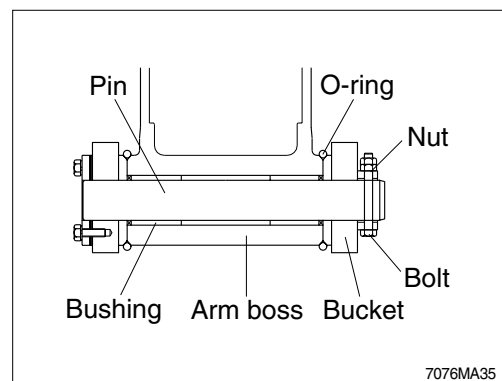
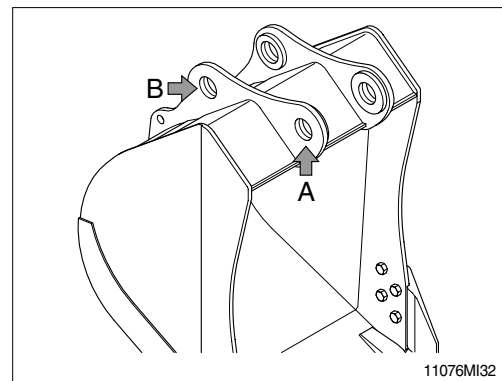
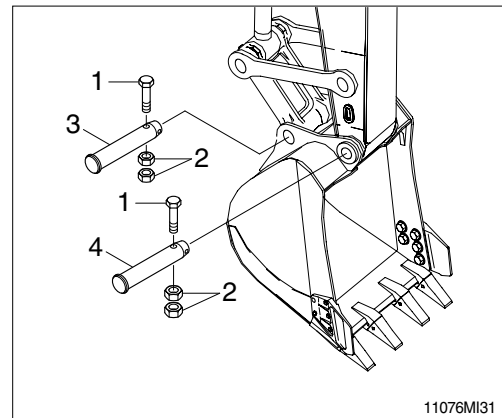
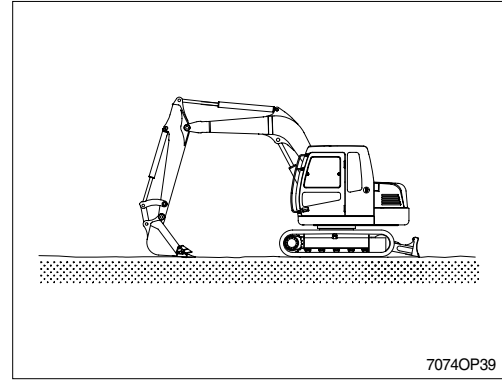

### 31) REPLACEMENT OF BUCKET TOOTH

#### (1) Timing of replacement

- ① Check wearing condition as shown in the illustration and replace tooth tip before adapter starts to wear.
- ② If excessive use, tooth adapter has worn out, replacement may become impossible.

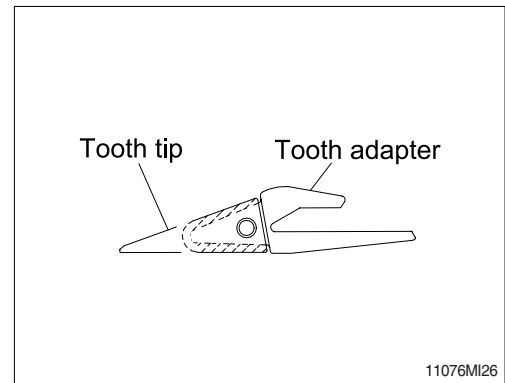

#### (2) Instructions for replacement

- ① Pull out pin by striking pin with punch or hammer, avoiding damage to locking washer.
- ② Remove dust and mud from surface of tooth adapter by using knife.
- ③ Place locking washer in its proper place, and fit tooth tip to adapter.
- ④ Insert pin until locking washer is positioned at tooth pin groove.

▲ Personal injury can result from bucket falling.

▲ Block the bucket before changing tooth tips or side cutters.

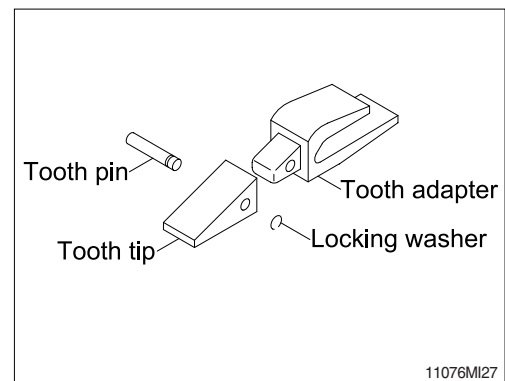

### 32) ADJUSTMENT OF BUCKET CLEARANCE

- (1) Lower the bucket on the ground as the picture shown in the right.
- (2) Swing to the left and keep the arm boss to be contact to the bucket left.
- (3) Lock the safety lever to the LOCK position and stop the engine.
- (4) Measure the clearance(A) between bucket and arm boss. This is the total clearance.

#### (5) Adjusting

- ① Loosen bolt(2), and remove washer(3), plate(1) and shim(4).
- ② Remove the shim equivalent value with measuring value.
- ③ Assemble the parts in the reverse order of removal.
  - Tightening torque :  $29.6 \pm 3.2 \text{kgf} \cdot \text{m}$   
( $214.0 \pm 23.1 \text{lbf} \cdot \text{ft}$ )
  - Normal clearance :  $0 \sim 0.5 \text{mm}$   
( $0 \sim 0.02 \text{in}$ )

※ If the bucket is not adjusted correctly, noise and vibration created during operation, and damaged O-ring, pin and bushing quickly.

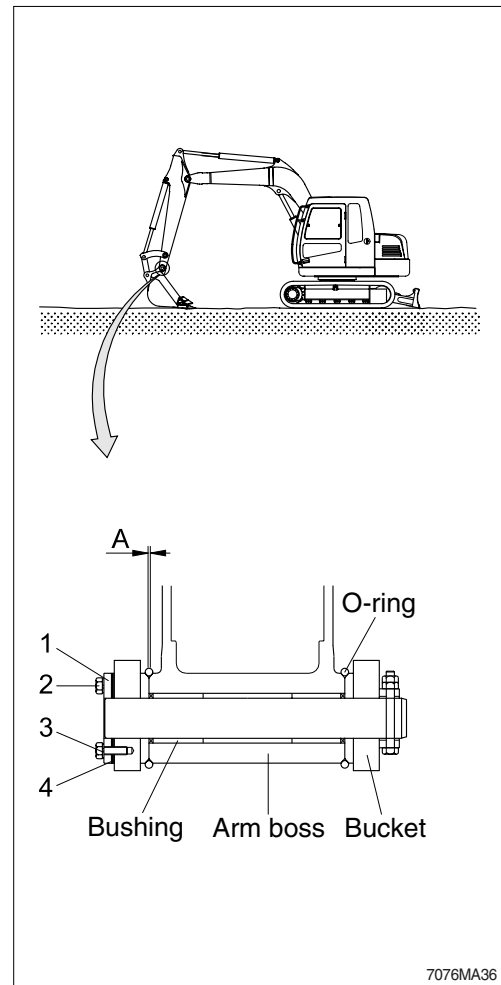

### 33) LUBRICATE PIN AND BUSHING

#### (1) Lubricate to each pin of working device

Lubricate the grease to the grease nipple according to the lubricating interval.

No.	Description	Qty
1	Boom and frame connection pin	3
2	Boom cylinder pin	1
3	Arm cylinder manifold	1
4	Arm cylinder pin(Rod side)	1
5	Boom and arm connection pin	1
6	Bucket cylinder pin(Head, rod)	2
	Bucket link(Control rod)	2
	Arm and bucket connection pin	1
	Arm and control link connection pin	1
7	Dozer blade cylinder pin	4

※ Shorten lubricating interval when working in the water or dusty place.

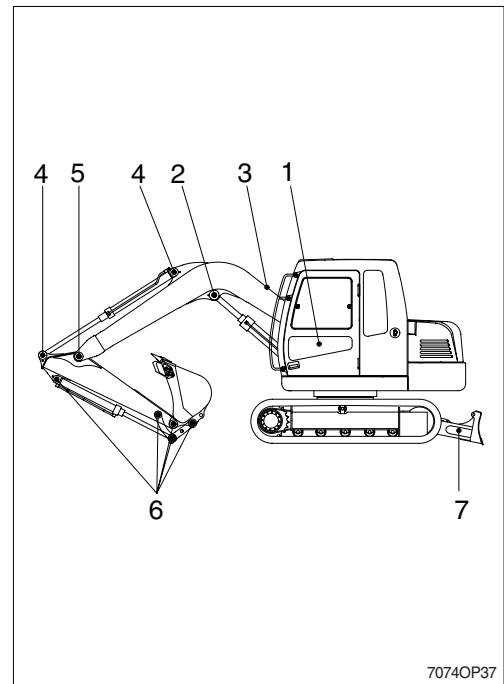

7074OP37

(2) Dust seals are mounted on the rotating part of working device to extend the lubricating interval.

※ Mount the lip to be faced outside when replace the dust seal.

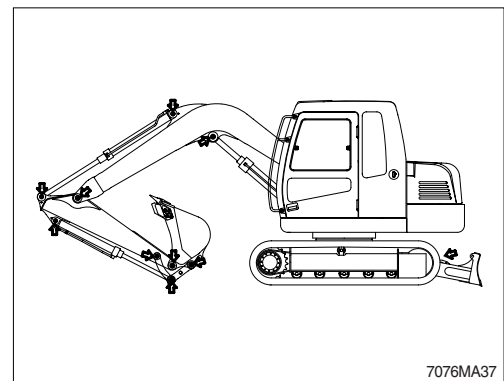

7076MA37

※ If it is assembled in wrong direction, it will cause fast wear of pin and bushing, and create noise and vibration during operation.

※ Assemble the seal same direction with picture and use with plastic hammer when replace.

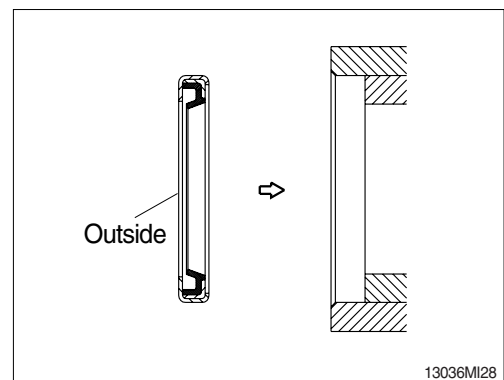

13036MI28