

2. DIMENSION AND WEIGHT

1) Base machine

Mark	Description	Unit	Specification
L	Length	mm(ft-in)	3090(10' 2")
H	Height	mm(ft-in)	2650(8' 8")
Wd	Width	mm(ft-in)	2260(7' 5")
Wt	Weight	kg(lb)	6570(14480)

※ With 450mm(18") triple grouser shoes and 540kg(1190lb) counterweight.

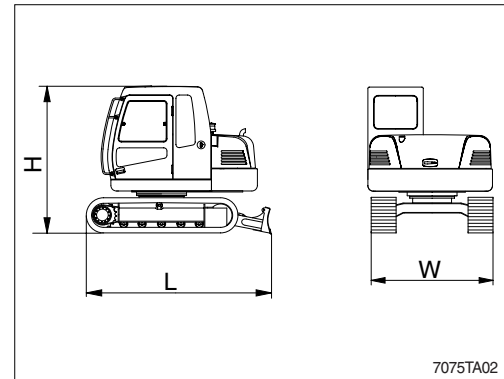

2) Boom assembly

Mark	Description	Unit	Specification
L	Length	mm(ft-in)	3850(12' 8")
H	Height	mm(ft-in)	1480(4'10")
W	Width	mm(ft-in)	410(1' 4")
Wt	Weight	kg(lb)	610(1350)

※ 3.7m(12' 2") boom with arm cylinder(Included piping and pins).

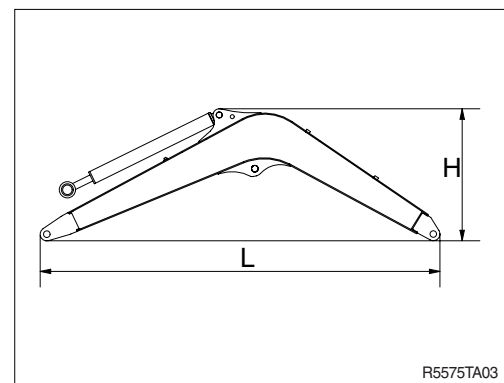

3) Arm assembly

OMark	Description	Unit	Specification
L	Length	mm(ft-in)	2230(7' 4")
H	Height	mm(ft-in)	610(2' 0")
W	Width	mm(ft-in)	220(0' 9")
Wt	Weight	kg(lb)	310(680)

※ 1.67m(5' 6") arm with bucket cylinder(Included linkage and pins).

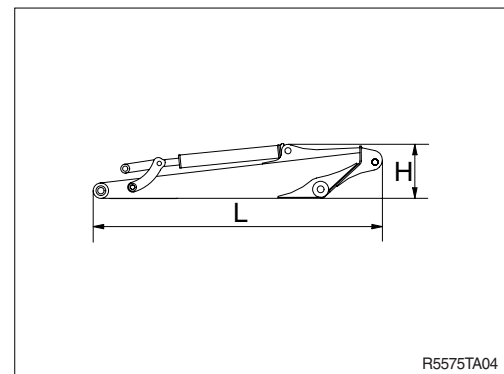

4) Bucket assembly

Mark	Description	Unit	Specification
L	Length	mm(ft-in)	1170(3'10")
H	Height	mm(ft-in)	710(2' 4")
W	Width	mm(ft-in)	750(2' 6")
Wt	Weight	kg(lb)	230(510)

※ 0.28m³(0.37yd³) SAE heaped bucket(Included tooth and side cutters).

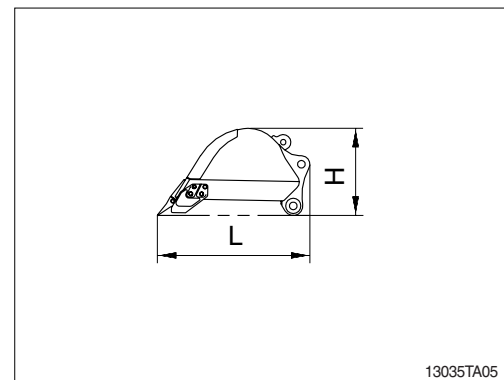

5) Boom cylinder

Mark	Description	Unit	Specification
L	Length	mm(ft-in)	1550(5' 1")
H	Height	mm(ft-in)	260(0'10")
W	Width	mm(ft-in)	200(0' 8")
Wt	Weight	kg(lb)	120(260)

※ Included piping.

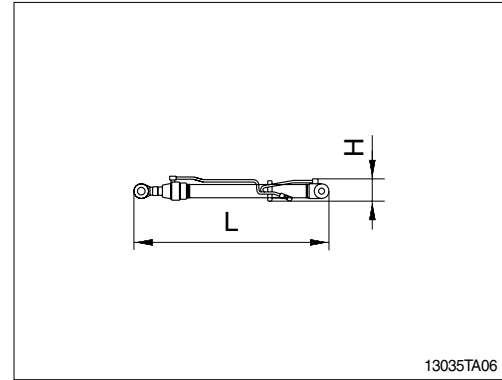

13035TA06

6) Cab assembly

Mark	Description	Unit	Specification
L	Length	mm(ft-in)	1962(6' 5")
H	Height	mm(ft-in)	1676(5' 6")
W	Width	mm(ft-in)	1288(4' 3")
Wt	Weight	kg(lb)	310(680)

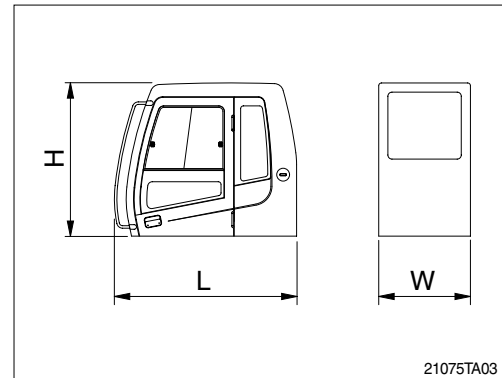

21075TA03

7) Counterweight

Mark	Description	Unit	Specification
L	Length	mm(ft-in)	2250(7' 5")
H	Height	mm(ft-in)	400(1' 4")
W	Width	mm(ft-in)	827(2' 9")
Wt	Weight	kg(lb)	540(1190)

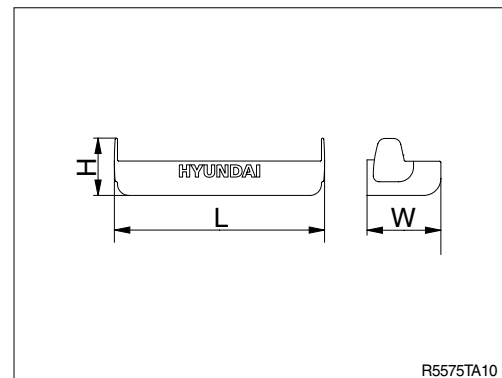

R6575TA10